



US005777350A

United States Patent [19]

Nakamura et al.

[11] Patent Number: **5,777,350**

[45] Date of Patent: **Jul. 7, 1998**

[54] **NITRIDE SEMICONDUCTOR LIGHT-EMITTING DEVICE**

5,652,434 7/1997 Nakamura et al. 257/76
5,670,798 9/1997 Schetzina 257/96

[75] Inventors: **Shuji Nakamura**, Tokushima; **Shinichi Nagahama**, Komatsushima; **Naruhito Iwasa**, Tokushima; **Hiroyuki Kiyoku**, Tokushima-ken, all of Japan

FOREIGN PATENT DOCUMENTS

6-21511 1/1994 Japan .

[73] Assignee: **Nichia Chemical Industries, Ltd.**, Japan

OTHER PUBLICATIONS

Jpn. J. Appl. Phys. vol. 34(1995) pp. L797-L799.
Jpn. J. Appl. Phys. vol. 34(1995) pp. L1332-L1335.
Appl. Phys. Lett. 67(13), 25 Sep. 1995.

[21] Appl. No.: **565,101**

[22] Filed: **Nov. 30, 1995**

[30] Foreign Application Priority Data

Dec. 2, 1994	[JP]	Japan	6-299446
Dec. 2, 1994	[JP]	Japan	6-299447
Dec. 22, 1994	[JP]	Japan	6-320100
Feb. 23, 1995	[JP]	Japan	7-034924
Mar. 16, 1995	[JP]	Japan	7-057050
Mar. 16, 1995	[JP]	Japan	7-057051
Apr. 14, 1995	[JP]	Japan	7-089102

Primary Examiner—Mahshid D. Saadat
Assistant Examiner—John Guay
Attorney, Agent, or Firm—Nixon & Vanderhye

[57] ABSTRACT

A nitride semiconductor light-emitting device has an active layer of a single-quantum well structure or multi-quantum well made of a nitride semiconductor containing indium and gallium. A first p-type clad layer made of a p-type nitride semiconductor containing aluminum and gallium is provided in contact with one surface of the active layer. A second p-type clad layer made of a p-type nitride semiconductor containing aluminum and gallium is provided on the first p-type clad layer. The second p-type clad layer has a larger band gap than that of the first p-type clad layer. An n-type semiconductor layer is provided in contact with the other surface of the active layer.

- [51] **Int. Cl.⁶** **H01L 33/00**
- [52] **U.S. Cl.** **257/96; 257/76; 257/97; 257/103; 257/13; 372/45**
- [58] **Field of Search** **257/76, 94, 96, 257/97, 14, 13, 103; 372/43, 45, 46**

[56] References Cited

U.S. PATENT DOCUMENTS

5,602,418 2/1997 Imai et al. 257/627

21 Claims, 6 Drawing Sheets

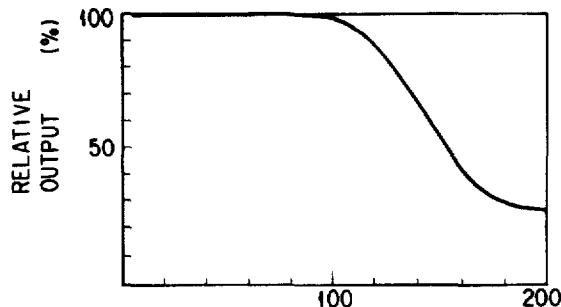
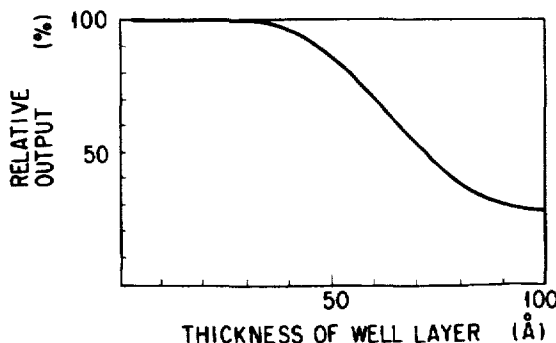
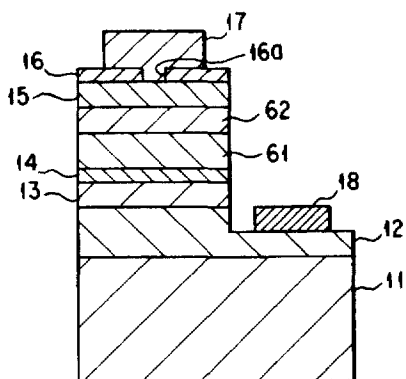

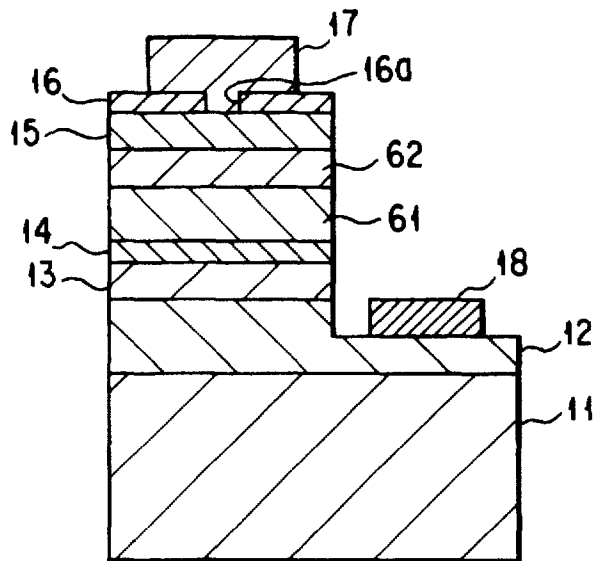

FIG. 1

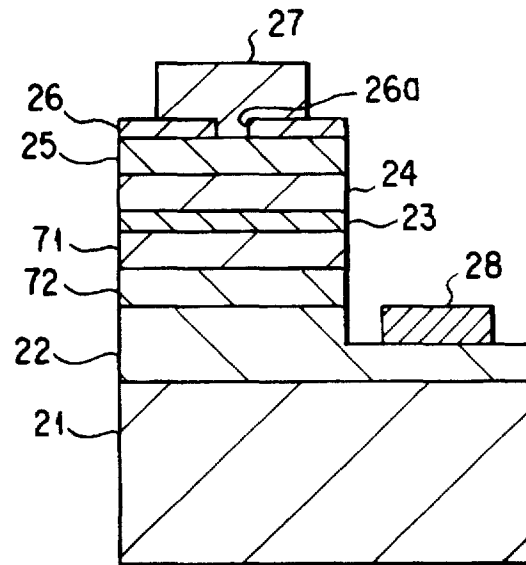

FIG. 2

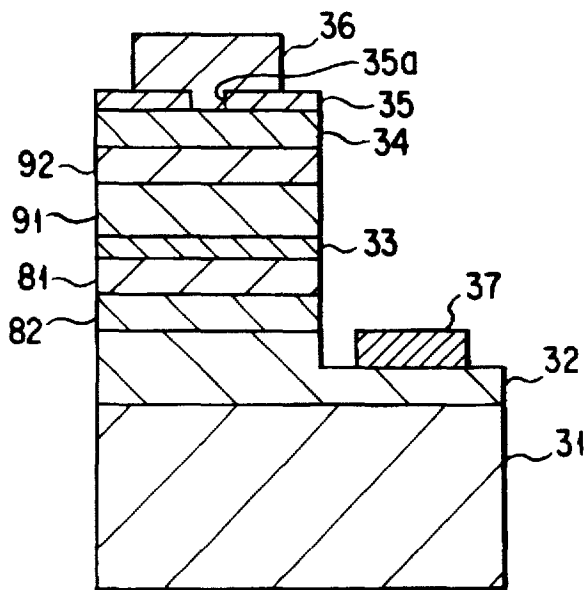

FIG. 3

FIG. 4

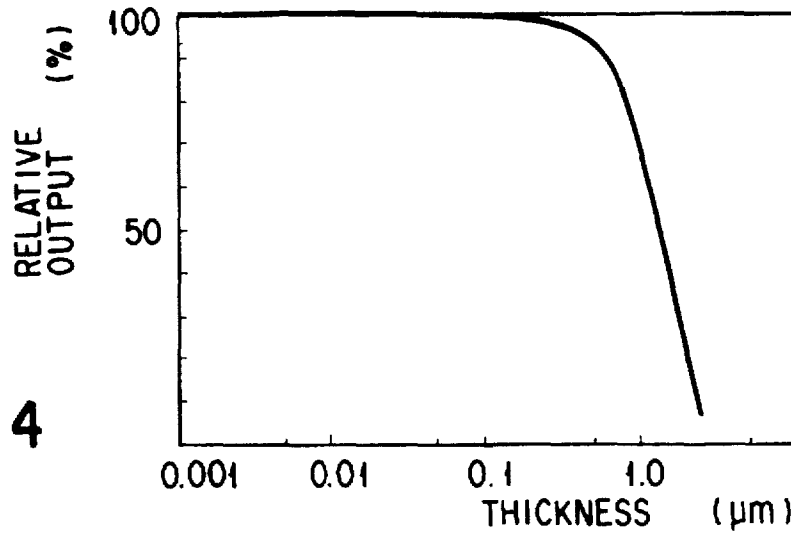

FIG. 5

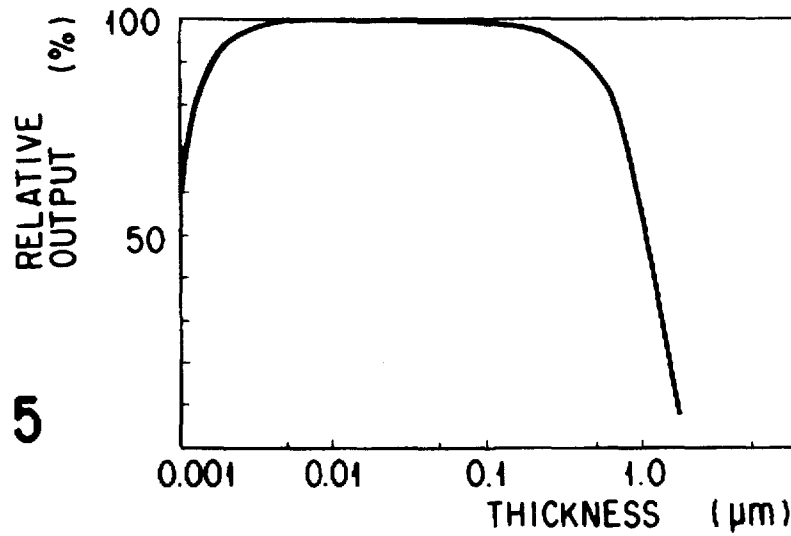
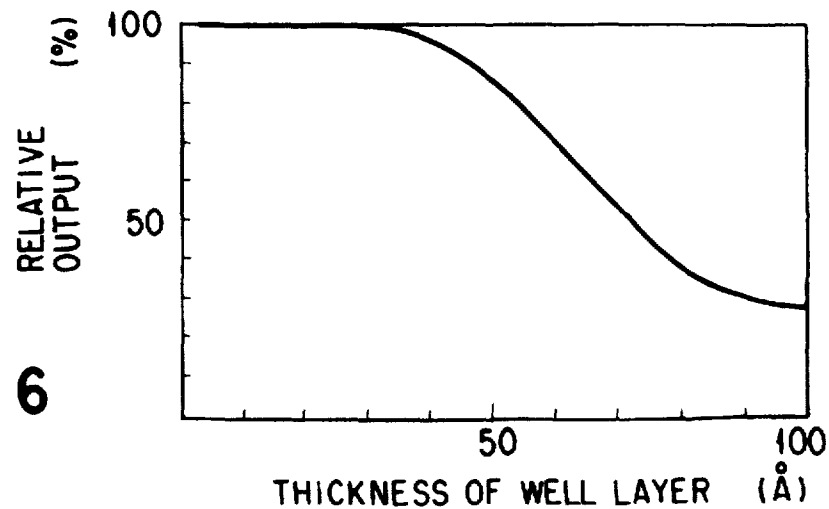

FIG. 6



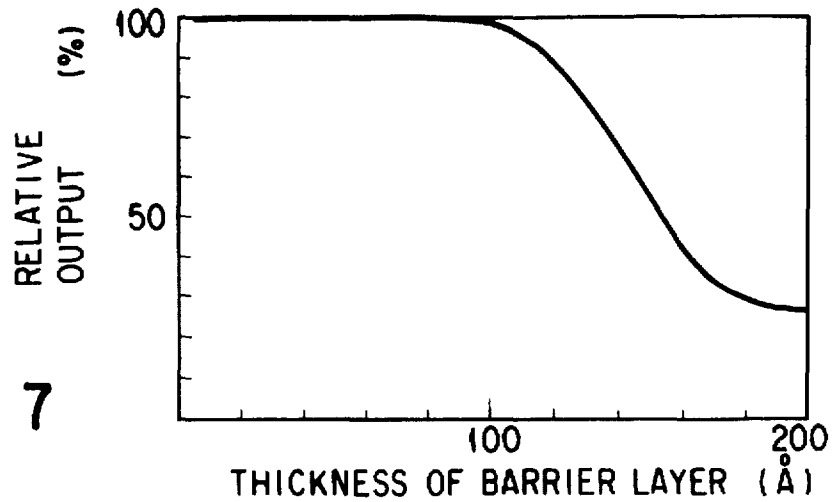

FIG. 7

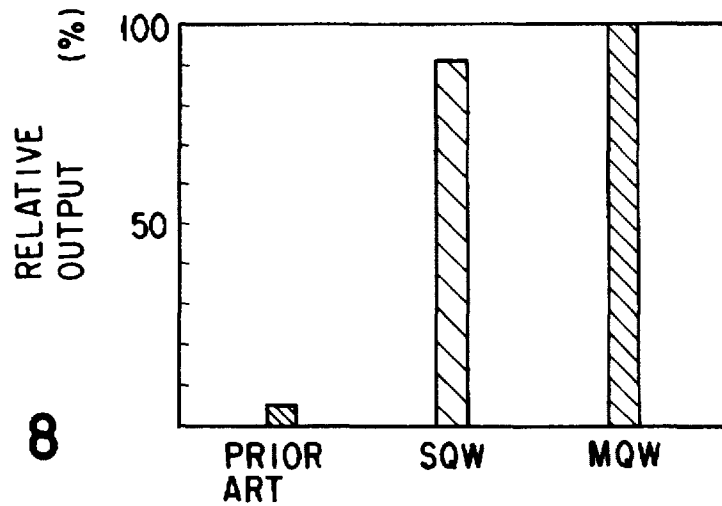

FIG. 8

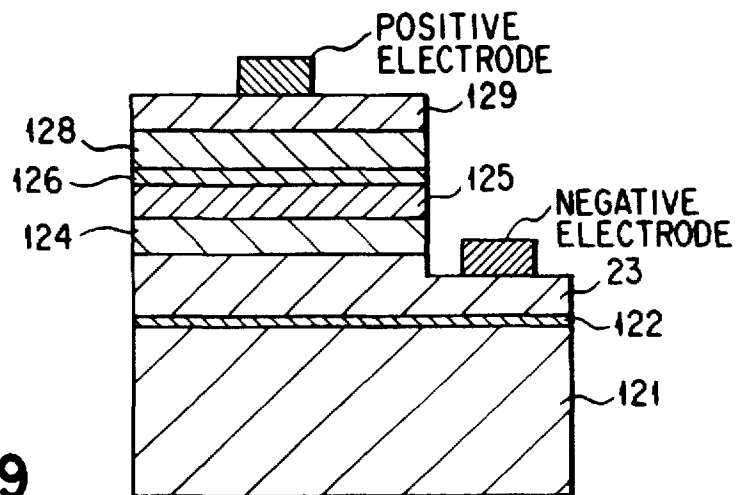

FIG. 9

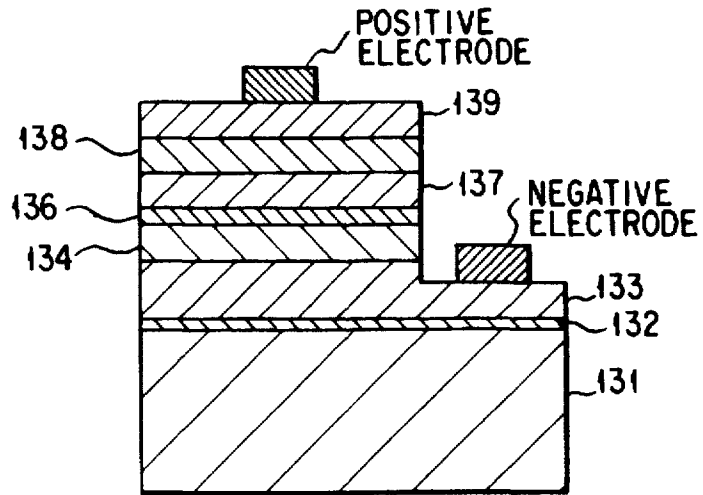

FIG. 10

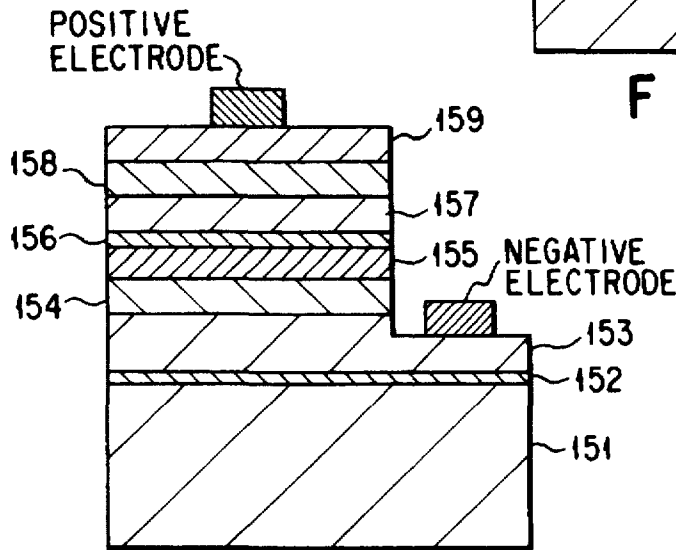

FIG. 11

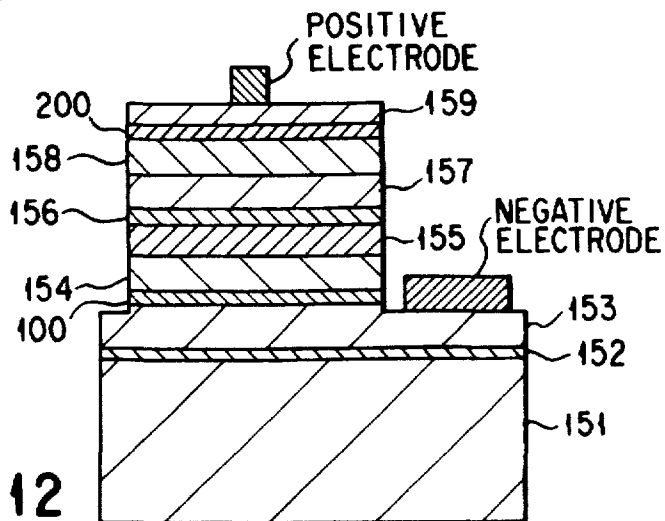

FIG. 12

Explore Litigation Insights

Docket Alarm provides insights to develop a more informed litigation strategy and the peace of mind of knowing you're on top of things.

Real-Time Litigation Alerts



Keep your litigation team up-to-date with **real-time alerts** and advanced team management tools built for the enterprise, all while greatly reducing PACER spend.

Our comprehensive service means we can handle Federal, State, and Administrative courts across the country.

Advanced Docket Research



With over 230 million records, Docket Alarm's cloud-native docket research platform finds what other services can't. Coverage includes Federal, State, plus PTAB, TTAB, ITC and NLRB decisions, all in one place.

Identify arguments that have been successful in the past with full text, pinpoint searching. Link to case law cited within any court document via Fastcase.

Analytics At Your Fingertips



Learn what happened the last time a particular judge, opposing counsel or company faced cases similar to yours.

Advanced out-of-the-box PTAB and TTAB analytics are always at your fingertips.

API

Docket Alarm offers a powerful API (application programming interface) to developers that want to integrate case filings into their apps.

LAW FIRMS

Build custom dashboards for your attorneys and clients with live data direct from the court.

Automate many repetitive legal tasks like conflict checks, document management, and marketing.

FINANCIAL INSTITUTIONS

Litigation and bankruptcy checks for companies and debtors.

E-DISCOVERY AND LEGAL VENDORS

Sync your system to PACER to automate legal marketing.