



US005915023A

United States Patent [19]
Bernstein

[11] **Patent Number:** **5,915,023**
[45] **Date of Patent:** **Jun. 22, 1999**

- [54] **AUTOMATIC PORTABLE ACCOUNT CONTROLLER FOR REMOTELY ARRANGING FOR TRANSFER OF VALUE TO A RECIPIENT**
- [76] Inventor: **Robert Bernstein**, 3229 Wilmette Ave., Wilmette, Ill. 60091
- [21] Appl. No.: **08/779,923**
- [22] Filed: **Jan. 6, 1997**
- [51] **Int. Cl.⁶** **H04L 9/00**
- [52] **U.S. Cl.** **380/24**; 380/4; 380/9; 380/23; 380/25; 380/49; 705/26; 705/35; 705/39; 705/40; 705/44
- [58] **Field of Search** 380/4, 9, 21, 49, 380/50, 59, 23, 24, 25; 705/26, 39, 40, 42, 44, 45, 35

4,977,502	12/1990	Baker et al. .	
5,017,766	5/1991	Tamada et al. .	
5,025,373	6/1991	Keyser, Jr. et al. .	
5,050,207	9/1991	Hitchcock .	
5,130,519	7/1992	Bush et al.	235/380
5,157,717	10/1992	Hitchcock .	
5,180,902	1/1993	Schick et al.	235/380
5,221,838	6/1993	Gutman et al.	235/379
5,265,162	11/1993	Bush et al.	380/24
5,266,782	11/1993	Alanära et al.	235/380
5,347,580	9/1994	Molva et al.	380/25

FOREIGN PATENT DOCUMENTS

85115722 10/1985 European Pat. Off. .

Primary Examiner—Bernarr E. Gregory
Attorney, Agent, or Firm—Welsh & Katz, Ltd.

[57] **ABSTRACT**

An apparatus and method of transferring a value from a transferor to a transferee in a transaction executed through a public service telephone network. The method includes the step of exchanging essential information between the transferor and transferee through a connection established through the public service telephone network. A summary of the transaction is transferred from the transferor and from the transferee to a third party agent of the transferee through the public service telephone network. The summary received from the transferor with the summary received from the transferee and where a match is determined, transferring the value to the transferee.

22 Claims, 4 Drawing Sheets

- [56] **References Cited**
- U.S. PATENT DOCUMENTS**
- 4,277,837 7/1981 Stuckert .
- 4,302,810 11/1981 Bouricius et al. 380/24
- 4,454,414 6/1984 Benton 235/379
- 4,536,647 8/1985 Atalla et al. 235/379
- 4,614,861 9/1986 Pavlov et al. 235/380
- 4,630,201 12/1986 White .
- 4,634,845 1/1987 Hale et al. .
- 4,689,478 8/1987 Hale et al. 235/380
- 4,734,858 3/1988 Schlafly .
- 4,906,828 3/1990 Halpern 235/379

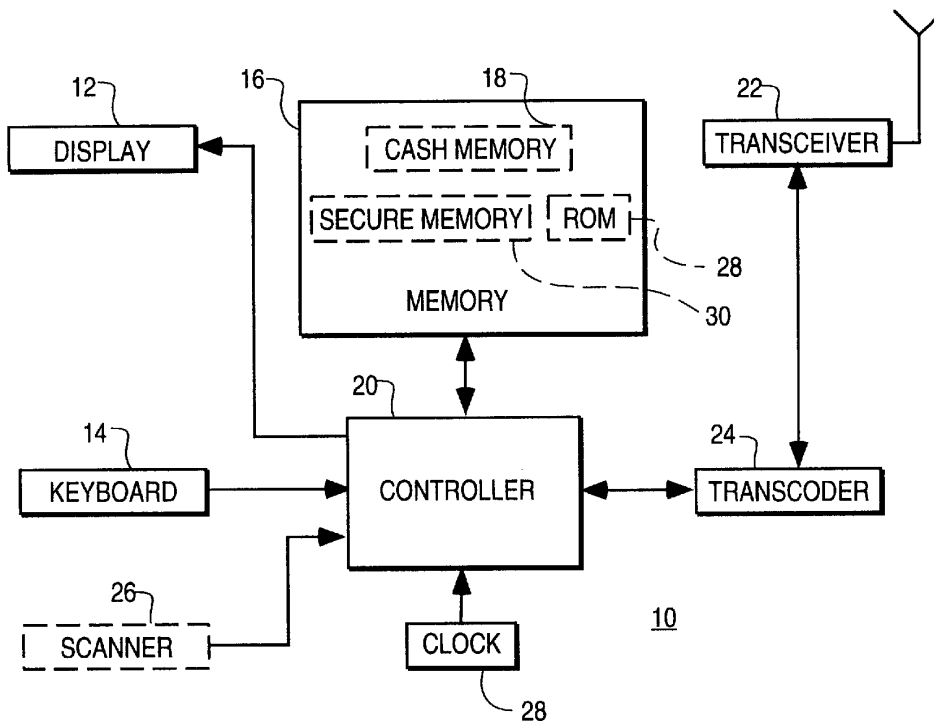

FIG. 1

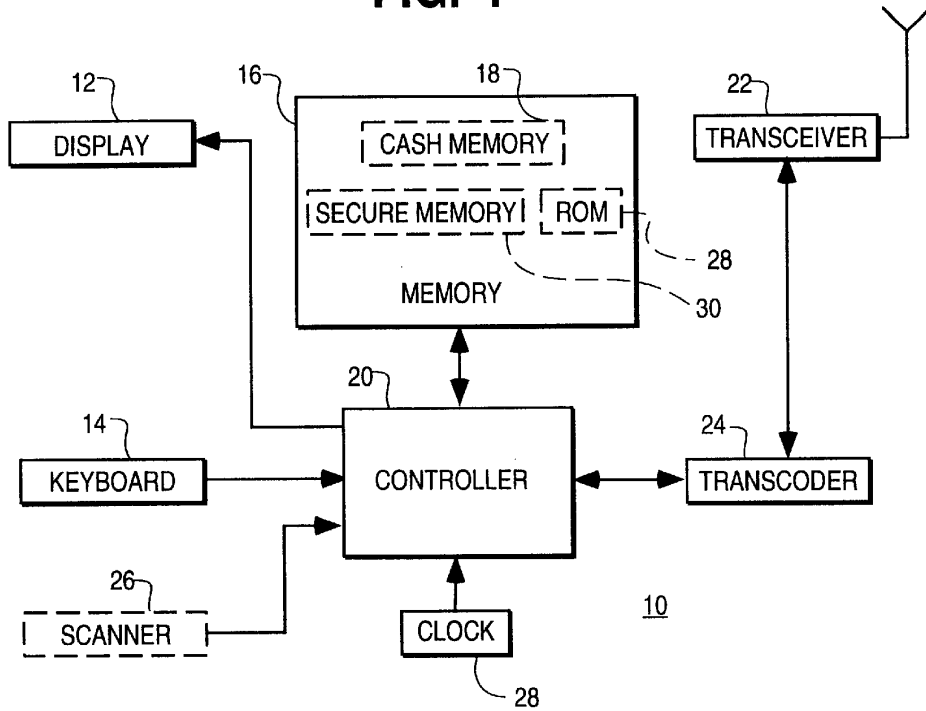

FIG. 2

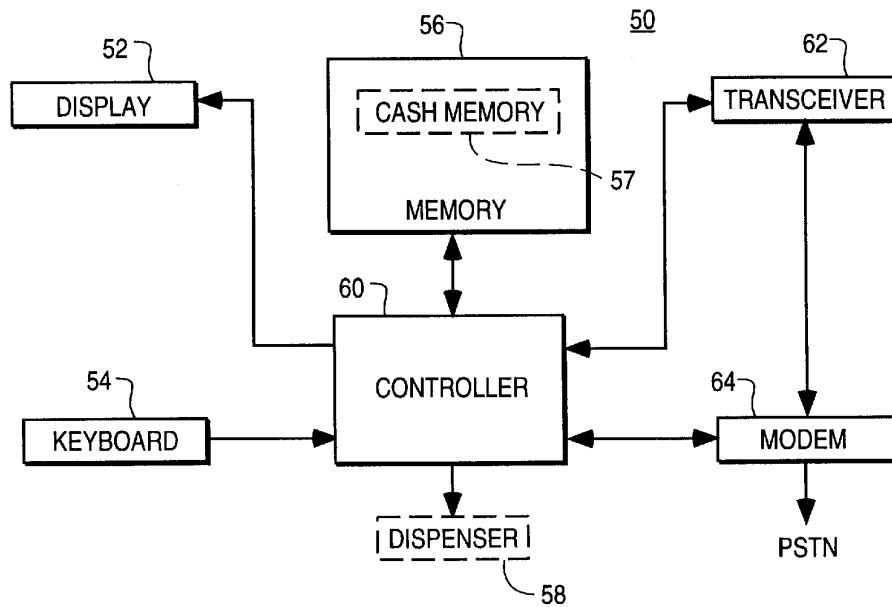

FIG. 3

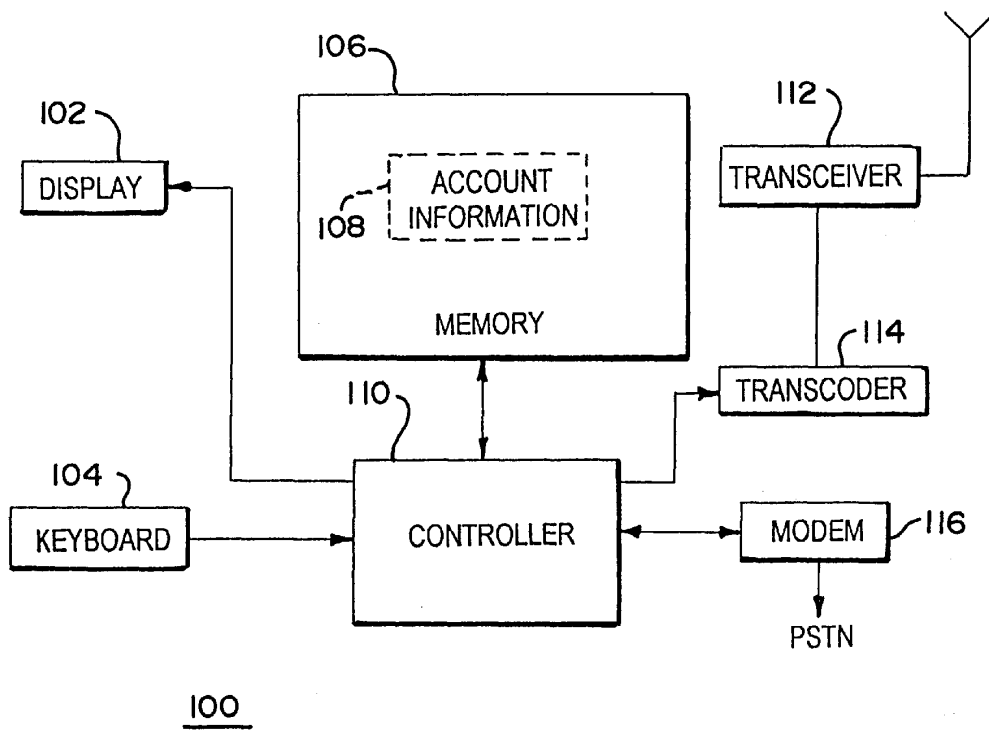

FIG. 4

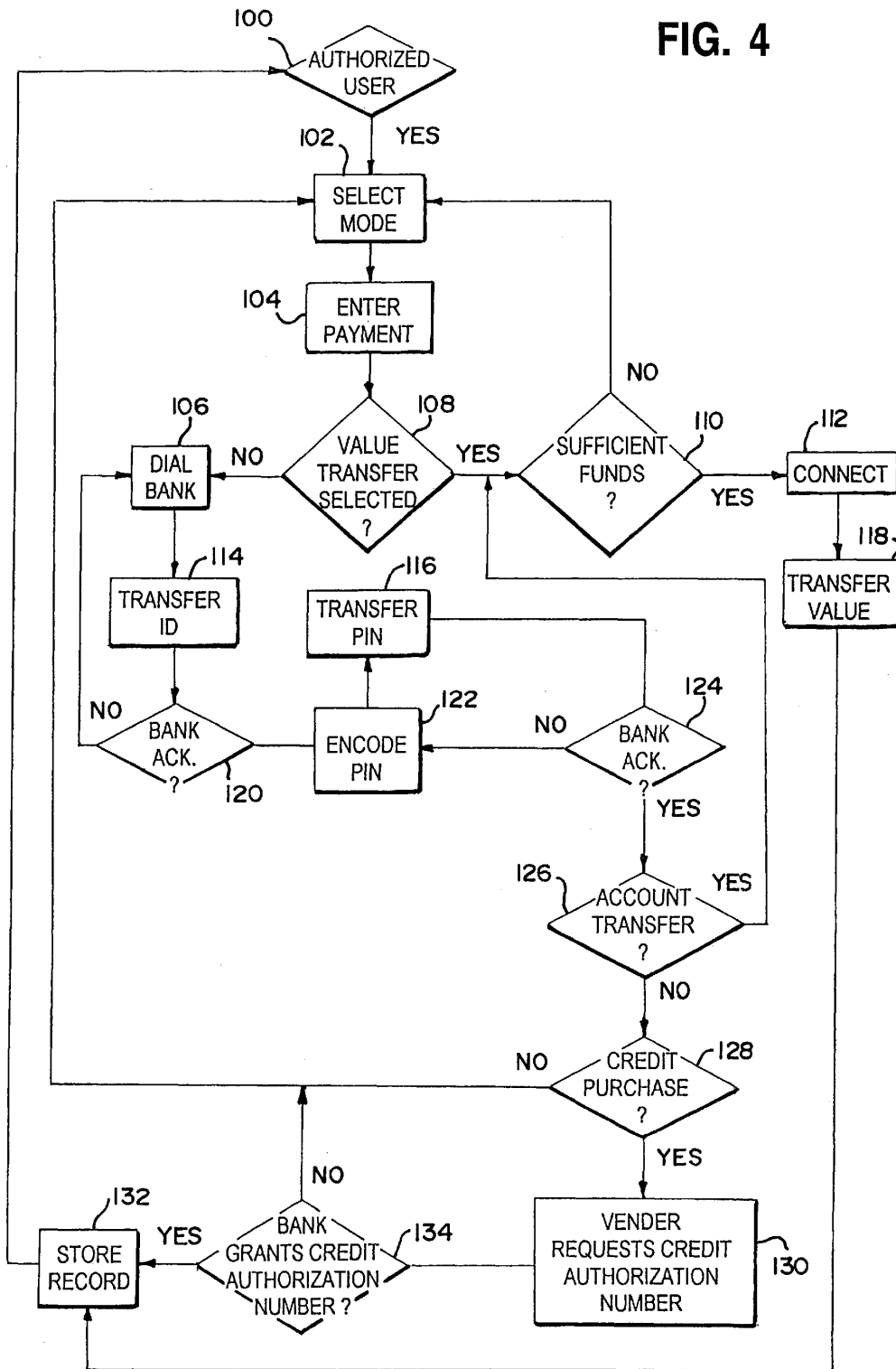

FIG. 5

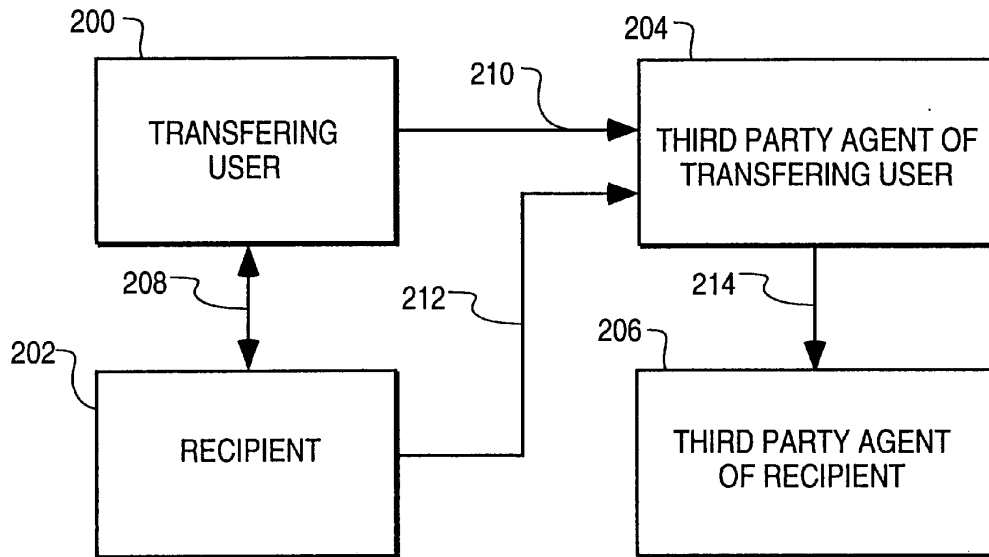
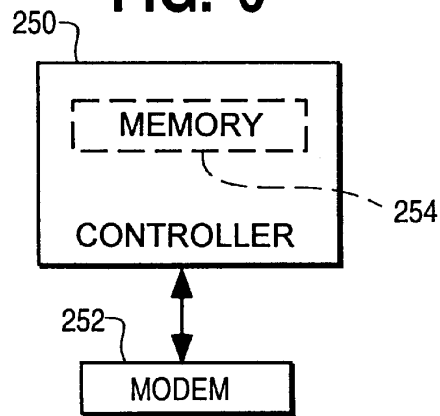

FIG. 6



204, 206

Explore Litigation Insights

Docket Alarm provides insights to develop a more informed litigation strategy and the peace of mind of knowing you're on top of things.

Real-Time Litigation Alerts



Keep your litigation team up-to-date with **real-time alerts** and advanced team management tools built for the enterprise, all while greatly reducing PACER spend.

Our comprehensive service means we can handle Federal, State, and Administrative courts across the country.

Advanced Docket Research



With over 230 million records, Docket Alarm's cloud-native docket research platform finds what other services can't. Coverage includes Federal, State, plus PTAB, TTAB, ITC and NLRB decisions, all in one place.

Identify arguments that have been successful in the past with full text, pinpoint searching. Link to case law cited within any court document via Fastcase.

Analytics At Your Fingertips



Learn what happened the last time a particular judge, opposing counsel or company faced cases similar to yours.

Advanced out-of-the-box PTAB and TTAB analytics are always at your fingertips.

API

Docket Alarm offers a powerful API (application programming interface) to developers that want to integrate case filings into their apps.

LAW FIRMS

Build custom dashboards for your attorneys and clients with live data direct from the court.

Automate many repetitive legal tasks like conflict checks, document management, and marketing.

FINANCIAL INSTITUTIONS

Litigation and bankruptcy checks for companies and debtors.

E-DISCOVERY AND LEGAL VENDORS

Sync your system to PACER to automate legal marketing.