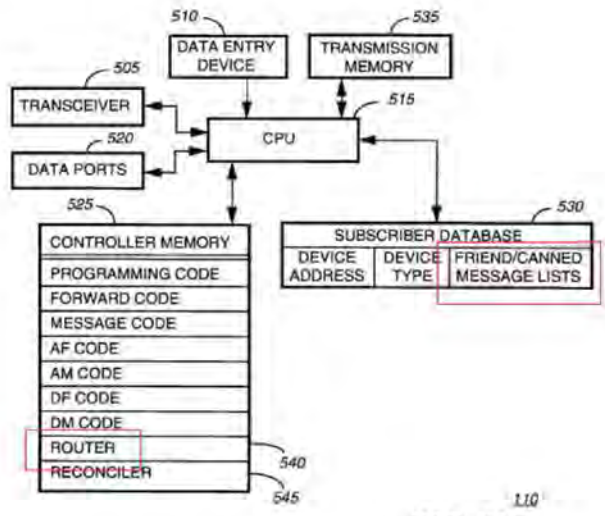


Annotation 1

FIG. 2

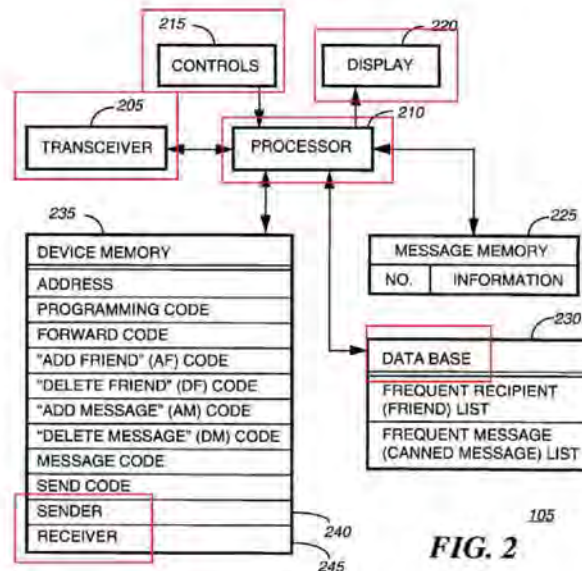
45. Cannon discloses that databases of frequently transmitted messages and the associated message aliases are stored at the system controller 110 and the PMUs 105 "so that each device can recognize an alias and conveniently interpret the more lengthy message or friend address associated therewith." *Id.* at 2:28-32. See also 2:46-51, which describes that a PMU 105 includes a database 210, as shown in Annotation 1 of Fig. 2 (reproduced above), for storing the "frequent message (canned message) list," i.e., the files of canned messages and the associated message codes, which are referred to in Cannon as "message aliases." Cannon discloses that both a message originator PMU 105 and a destination PMU 105 store such files or lists of canned messages and the associated message aliases. *Id.* at 5:1-6.
  
46. With reference to the system controller 110, Cannon discloses that the system controller includes, as illustrated in Annotation 1 of Fig. 12 (reproduced below), a subscriber database 530 for storing lists of canned messages and associated message aliases corresponding to each subscriber of the communications system 100. The controller 110 also includes a controller memory 525 that stores information used in programming the controller and various codes, such as programming code, forward code, message code and "AF, AM, DF, and DM codes." *Id.* at 7:35-45.



Annotation 1

FIG. 12

47. One of ordinary skill in the art would have understood that the "message aliases" described in Cannon correspond to the message codes described in the '506 Patent, whereas the "message codes" described in Cannon are used to indicate a function to be performed to send or receive messages. *Id.* at 3:60-61 and 4:63-64. One of ordinary skill in the art would have understood that the database 210 in a PMU 105 or the database 530 in a system controller 110 includes memory that stores the lists of canned messages and the associated message aliases.
48. According to Cannon, the system controller 110 can update the databases of the frequently transmitted messages and the associated message aliases that are stored both at the system controller 110 and the PMUs 105 when necessary so that the information stored in a PMU database is equivalent to that stored in the controller database. *Id.* at 2:34-38. Cannon discloses that a "data entry device 510 can be used to update the subscriber database 530." *Id.* at 7:39-40. Cannon further discloses that system controller includes "a reconciler for determining that the message alias is not included in the list associated with the portable messaging unit." *Id.* at 11:8-10. One of ordinary skill in the art would have understood that the files or lists of canned messages and message aliases that are maintained at the sender and receiver PMUs and at the system controller in one implementation can be identical to each other, and that the system controller can perform actions to maintain these lists consistent across all the devices.



Annotation 2

FIG. 2

49. Describing a PMU 105 in general, Cannon provides an electrical block diagram of a PMU 105 in Fig. 2, and discloses that the PMU 105 includes a processor 210 "for controlling the operations of the PMU 105," a display 225 that presents information to a user of the PMU "in response to activation by the processor 210" and a transceiver 205 "for sending and receiving information over a radio frequency communication channel." *Id.* at 2:39-46. See also Annotation 2 of Fig. 2 (reproduced herein). The PMU 105 further includes message memory 225 that is coupled to the processor 210 for "storing received messages and message numbers associated with the received messages" and, as described above, the database 230.
50. One of ordinary skill in the art would have understood that either or both of the sender and receiver PMU 105 described in Cannon can be a portable two-way messaging device, such as a two-way pager. One of ordinary skill in the art would have also understood that the processor 210 can coordinate with one or more of the message memory 225, the database 230 and the device memory 235 to retrieve canned messages and associated message aliases from the frequent message list stored in the memory of the PMU 105, and display the retrieved canned messages to the user of the PMU 105 using the display 210.

51. One of ordinary skill in the art would further understand that the system controller 110 disclosed in Cannon can be a network device that is connected to both the originator and destination PMUs via network connections, where the system controller receives canned messages and message codes from an originator messaging device, and forwards the canned messages and message codes to a destination messaging device.
52. Cannon discloses that a PMU 105 includes a sender 240 module that prepares information for transmission from the PMU 105 when the PMU is sending messages and associated information. The sender 240 may include firmware "stored in the device memory 235 and executed by the processor 210," or the sender 240 may be implemented "using hardware capable of performing equivalent operations." *Id.* at 4:1-8. See also Annotation 2 of Fig. 2.
53. Describing the operation of sending a message from the originator PMU 105, Cannon discloses that a user-initiated signal may be received from the controls 215 (see Annotation 2 of Fig. 2) indicating that a message is to be transmitted to another device. Upon receiving the signal, the sender 240 in the originator PMU 105 references the database 230 to determine whether the entered message is a canned message. Then the sender 240 provides the message information or message alias associated with the selected canned message to the transceiver 205 (see Annotation 2 of Fig. 2), along with the message code, the friend alias or recipient address, for transmission from the PMU 105 to the system controller 110. *Id.* at 5:10-12, 5:29 and 5:56-66.
54. As an example of a frequent transmitted message sent from the originator PMU 105 to the system controller 110 for forwarding to the destination PMU 105, Cannon describes that the PMU 105 transmits a frequently transmitted message by sending the message alias, along with the message code, the friend alias, in a transmission to the system controller 110, as illustrated by Fig. 10 (reproduced below).



55. Based on the above teaching of the '506 Patent and in view of my education and experience, a person of ordinary skill in the art at the time of filing the '506 Patent would have understood that,

- when the sender 240 is implemented as program code, e.g., firmware, the processor 210 in the originator PMU 105 may execute sender 240 code to compile the message alias associated with the selected canned message along with the message code, the friend alias or recipient address, and/or other associated message information, into a signal for transmission to the system controller 110. A person of ordinary skill in the art would have also understood that, when the sender 240 is implemented as using hardware, the sender 240 hardware may execute instructions to compile the message alias associated with the selected canned message along with the message code, the friend alias or recipient address, and/or other associated message information, into a signal for transmission to the system controller 110.
56. Describing the operation of the system controller 110, Cannon discloses that the system controller includes a router 540 (see Annotation 1 of Fig. 12) that is activated upon receiving a signal from the originator PMU 105 that includes a message alias. *Id.* at 8:20-38. The router relays the message alias corresponding to the signal received from the originator PMU 105 to the destination PMU 105. *Id.* at 8:39-58.
57. Describing the operation of receiving a canned message by a PMU 105, Cannon discloses that, upon receiving a message that is routed by the system controller 110, a destination PMU 105 activates a receiver 245 (see Annotation 2 of Fig. 2), which may be firmware executed by the processor 210, or may be implemented in hardware capable of performing equivalent operations. *Id.* at 4:4-12, 4:62-67. Specifically, the receiver 245 compares the received message information with aliases in the message list stored in the PMU 105's memory. When the received message alias matches to an alias stored in the message list, the receiver 245 retrieves the corresponding canned message from the message list. Then the destination PMU 105 can display the retrieved canned message associated with the message alias sent by the originator PMU 105 using the display 220. *Id.* at 5:1-9.

### III. DISCUSSION OF WILL AND COMBINATION WITH CANNON

58. In general, Will discloses a "method and apparatus for sending paging signals and messages to individuals within a building and accepting responses to the messages." APL-1006, abstract. An electronic communications system may be used to transmit message data to a portable receiver, which can be a miniature communications unit that is carried by an individual user. *Id.* at 1:18-25,

3:66-4:1. See also of Fig. 1 (annotated below). One of ordinary skill in the art would have understood that the communications unit disclosed in Will may include a two-way pager.

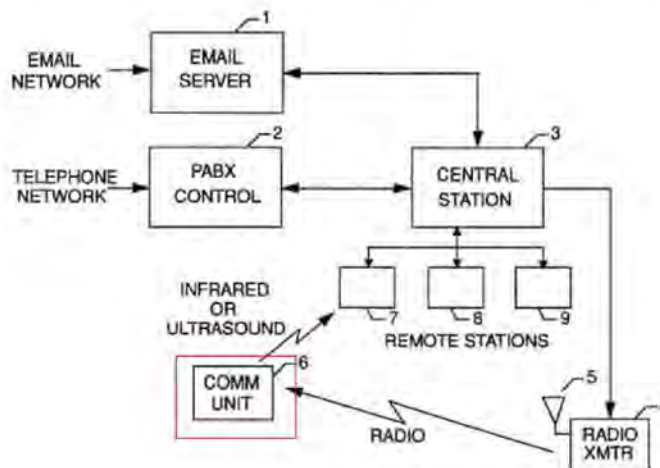


FIG. 1

59. Describing the hardware structure of the communications unit, as illustrated in Fig. 3 (annotated below), Will discloses that the communications unit includes a microprocessor 25. A programmable ROM 30 is associated with the microprocessor and contains the program for the microprocessor. The communications unit also includes a RAM that contains messages after conversion to digital codes, information extracted from the messages for display to the user, and other information. *Id.* at 8:62, 9:9-15.
60. Will teaches that software executed by the microprocessor extracts information to be displayed, which is placed into a memory and causes characters to be displayed on the liquid crystal display 31. The communications unit includes a thumbwheel 32, which allows the user of the communications unit to display messages and responses that are retrieved from the memory. *Id.* at 9:9-26.

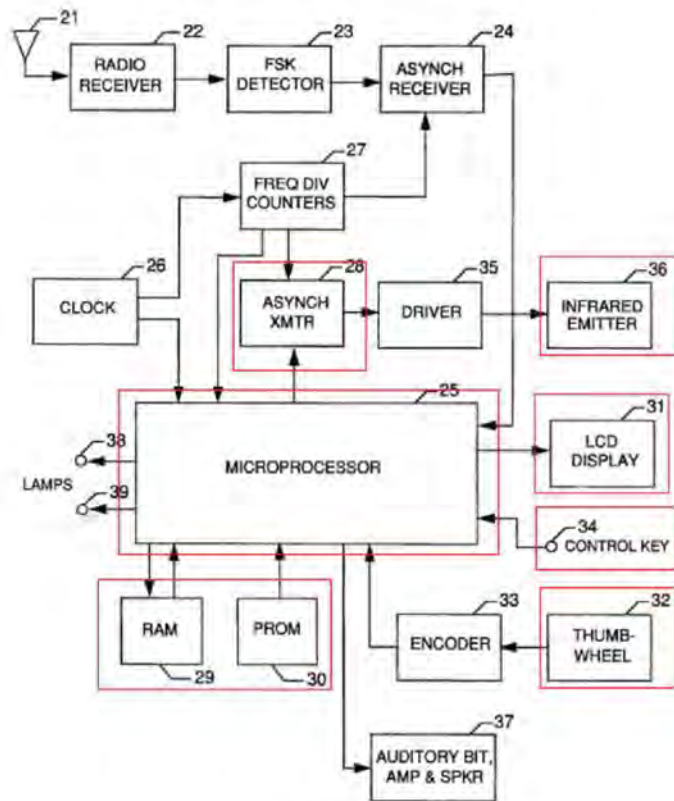


Fig. 3

61. Providing an illustration of the physical layout of the front of the remote communications unit, as shown in Fig. 4 (annotated below), Will discloses that the communications unit includes a liquid crystal display 44 that displays responses or messages. *Id.* at 9: 45-46, 9:62-65. The front of the communications unit includes a thumbwheel 49, which the user can rotate "to control the display of messages, responses, and other information." *Id.* at 10:6-10.

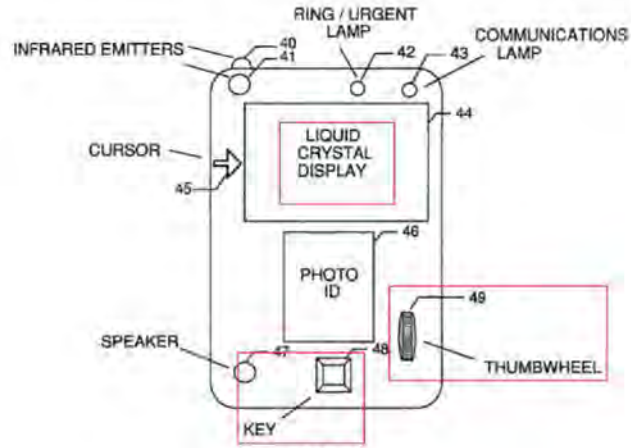


FIG. 4

62. Will provides examples of a variety of interfaces that are presented on the display of the communications unit. As shown by Fig. 33 (annotated below), the display 451 shows a typical message, which is presented in the form an inquiry. Response options that are associated with the message can also be displayed by the interface. The user of the communications unit can select from one of the response options that are displayed with the message, or choose from a set of preprogrammed responses, which is shown by display 454. *Id.* at 26:30-43. The user can also select from preprogrammed original messages, which is shown by display 455. *Id.* at 27:56-58. The user can select one of the preprogrammed messages or preprogrammed responses by orienting the display "using the thumbwheel so that the desired response is to the right of the cursor, and press[ing] the key." *Id.* at 26:43-47. See also Fig. 4 above.



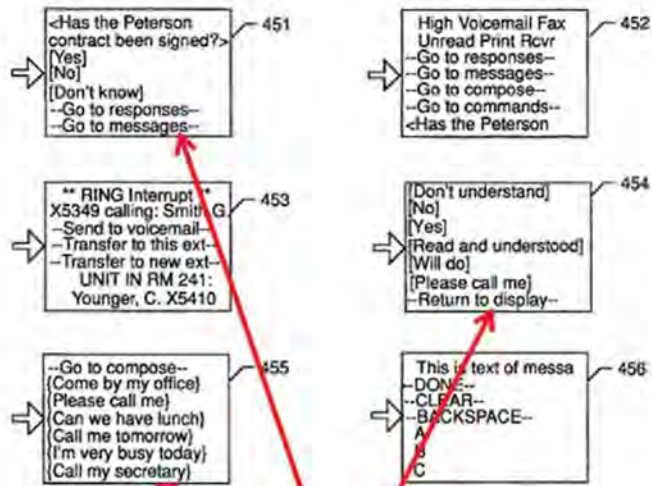


FIG. 33

Displays showing  
selectable  
response options

63. Will discloses that lists of preprogrammed messages and preprogrammed responses are stored in the display memory of the communications unit, as illustrated in Fig. 42 (annotated below). *Id.* at 36:35-48. The lists of preprogrammed messages and preprogrammed responses are stored in data structures in the display memory. *Id.* at 25:45-53. The lists of preprogrammed messages and preprogrammed responses are contained in data structures in both the communications unit and the central station. *Id.* at 12:62-65.

COMMUNICATIONS UNIT DATA STRUCTURES (CONTINUED)

DISPLAY MEMORY STRUCTURES

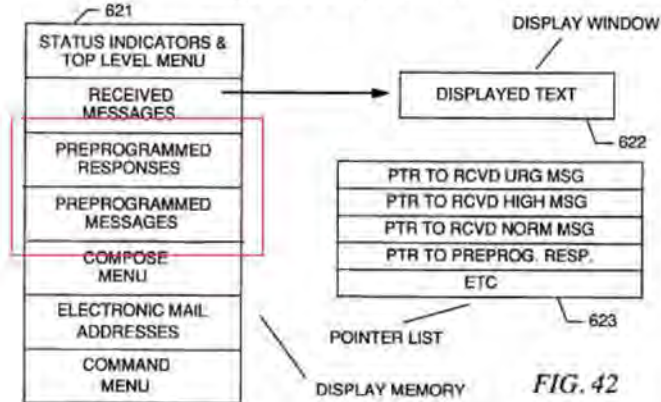


FIG. 42

64. Willis discloses that based on the user selection of the preprogrammed message or preprogrammed response, the communications unit transmits information in coded form to one or more remote stations for forwarding to the central station. *Id.* at abstract. Based on the user selection of a message or a response by pressing the control key 34, data is transmitted from the communications unit, with the microprocessor sending 8-bit characters to an asynchronous transmitter. *Id.* at 9:27-35. The software executed by the microprocessor includes a module for transmitting a packet from the communications unit. The software executes a command "that results in input data being transmitted to a remote station and then to the central station. If a response is selected a subpacket is formatted with an appropriate response sequence, including an Input Packet Number and a channel number indicating the destination address of the response. [] If an original message is selected a subpacket is formatted in the same manner as described above." 29:35-52.
65. Describing the format of a packet that is sent from the communications unit, as illustrated in Fig. 12 (annotated below), Willis discloses that the packet contains a two-character sequence, which consists of an "ASCII character 136 indicating the type of code, followed by a 7-bit character 137 indicating the particular code." 12:49-52. "If the type character 136 is an ENQ, this is a Response Code. If the 7-bit code that follows 137 is from 0 to 19, the response indicates one of the responses (with 0 referring to the first response, 1 to the second, etc.) included with the message sent to the

unit. If the code 137 is from 21 to 127, the response indicates one of the preprogrammed responses in the Preprogrammed Response List. []If the type character 136 is a BEL, this is a response but using one of the preprogrammed messages in the Preprogrammed Message List, as indicated by the code 0-127. []If the type character is a BS, this is an original message, with the message as indicated by the code 0-127 and retrieved from the Preprogrammed Message List." *Id.* at 12:54-13:11.

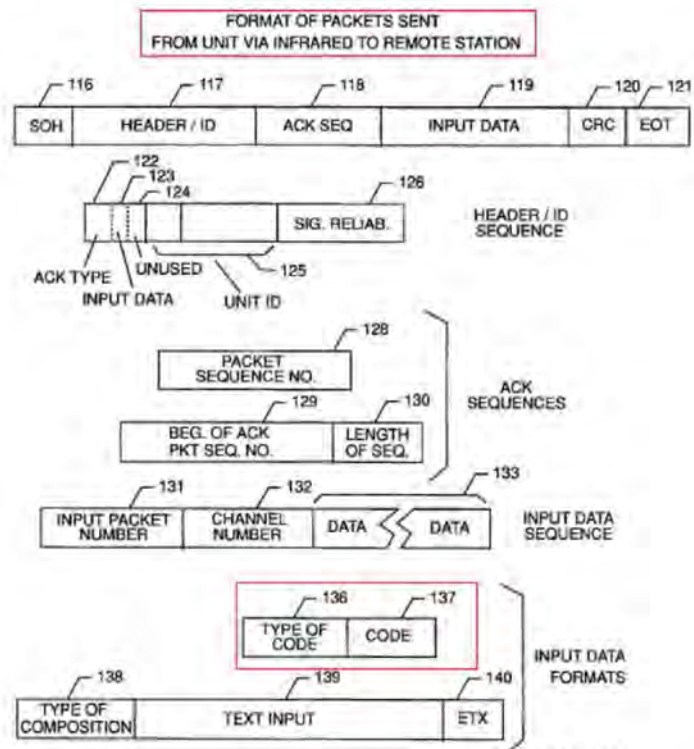


FIG. 12

66. Based on the above teaching of Will and in view of my education and experience, it is my understanding that, a person of ordinary skill in the art at the time of filing the '506 Patent would have understood that Will teaches that the communications unit can send codes corresponding to preprogrammed messages and/or preprogrammed responses, i.e., canned messages and/or canned responses to the central station, where synchronized copies of the canned messages and

- canned responses, along with associated codes, are maintained at both the communications unit and the central station.
67. One of ordinary skill in the art would have also understood that the microprocessor included in the communications unit can execute software code to retrieve the preprogrammed messages and/or preprogrammed responses from the data structures stored in the display memory, and display it on the LCD screen of the communications unit. One of ordinary skill in the art would have also understood that the user of the communications unit can use the thumbwheel and the key on the front face of the communications unit to select a preprogrammed message or a preprogrammed response from the lists of preprogrammed messages or responses that are displayed on the LCD screen of the communications unit. See, e.g., ¶¶62-68 and Will Figs. 3-4, 12 and 33 (reproduced above).
68. Furthermore, one of ordinary skill in the art would have understood that, based on user selection of a preprogrammed message and/or preprogrammed response, the software executed by the microprocessor compiles the selected message or response into a packet that includes a code corresponding to the selected message and/or response, apart from other information. The software sends the compiled packet to the asynchronous transmitter for transmission to the central station. See, e.g., 62-68 and Will Figs. 3-4, 12 and 33 (annotated above).
69. A person of ordinary skill in the art at the filing date of the '506 Patent would have combined Cannon with Will at least for the reasons discussed below.
70. Based on the teachings of Cannon and Will as outlined above, a person of ordinary skill in the art, at the filing date of the '506 Patent, would have readily appreciated that the two references provide teachings in similar fields of endeavor. Both describe communications systems that provide two-way messaging for portable messaging units. The two references also describe how the communication may be performed using preprogrammed messages, where shorter codes corresponding to the preprogrammed messages are transmitted over the communications channels, instead of sending the messages in full, and thereby "the communication channel is efficiently used to transmit relatively short transmissions, which prevents system capacity from being exceeded and which prevents message delays due to overcrowding of the channel," as taught by Cannon, APL-1004 at 9:34-37.

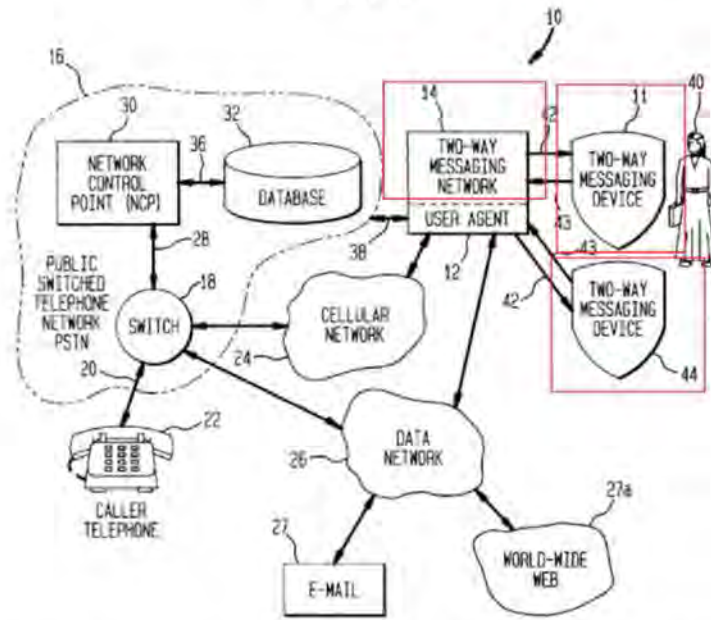
71. A person of ordinary skill in the art would have combined the teachings of Cannon with the teachings of Will to implement a message exchange between portable messaging units (PMUs), in which an originating PMU sends a frequently transmitted message to a recipient PMU with added response options and receive a response from the recipient, as taught by Will, where the frequently transmitted message with the response options is communicated from the originating PMU to the recipient through a system controller using message codes, as taught by Cannon. In more detail, Cannon teaches that PMUs communicate frequently transmitted messages using “relatively short” message aliases, *id.* at 2:21, that are communicated through an intermediate system controller, *see, e.g.*, APL-1004 at 2:19-32, 9:38-53 and 5:3-9, where the source and recipient PMUs and the system controller each stores databases of the frequently transmitted messages and the associated aliases, *see, e.g., id.* at 6:46-57. However, Cannon is silent about sending customizing the messages that are transmitted, *e.g.*, by adding response options. This is taught by Will, which discloses that the paging receiver may respond to the message by selecting from one of preprogrammed responses that are included with the message. *See, e.g., id.* at 4:41-54. Will further teaches that the paging receiver may send response codes corresponding to the preprogrammed responses. *See, e.g., id.* 12:47-13:1. In doing so, Will overtly details the operation of the recipient operating the paging receiver and selecting from a response, as recited by claim 11. *See, e.g., id.* at 25:61-27:64.
72. One of ordinary skill in the art would have augmented sending frequently transmitted information using relatively short message aliases, as taught by Cannon, by adding Will's preprogrammed response options to such messages, as this would have allowed a request-response interaction between the message originator and the recipient, and allowing to quickly and efficiently select a response from list of response options displayed with the message. As with sending the frequently transmitted information using relatively short message aliases, the selected response option is communicated to the message originator using a relatively short code.
73. Cannon's communication system may use Will's preprogrammed responses by storing, at each of the originating and recipient PMUs and the system controller, lists of frequently transmitted messages and associated aliases, and preprogrammed responses with associated response codes. The originating PMU may add preprogrammed response options to the frequently transmitted information by appending the corresponding response codes to the message alias that

is sent to the system controller, which forwards the message alias and the response codes to the recipient. While Will teaches that the response codes are sent from the receiving device to the central communications unit, one of skill in the art would readily appreciate that Will's concept of using response codes can be equally well implemented by Cannon's originating PMU, which already stores and sends message aliases corresponding to the selected messages, such that storing codes corresponding to response options that are added to the selected messages would be a natural and logical extension. The use of preprogrammed responses would allow Cannon's PMUs to establish a dialogue involving messages and corresponding responses that are exchanged using the shorter message aliases and response codes.

#### **IV. DISCUSSION OF LAPORTA AND COMBINATIONS WITH CANNON AND WILL**

74. In general, LaPorta discloses "a two-way wireless messaging system and method using a messaging network" that has "at least one subscriber user agent that stores messages that are forwarded to predetermined destinations." APL-1005, abstract. The user agent, which is associated with a messaging device, is located inside the two-way messaging network and stores messages that are associated with predetermined message codes. *Id.* at 2:5-8. See of Fig. 1 (annotated below).
75. LaPorta describes that a wireless messaging device stores messages along with associated predetermined numbers that serve as indices to the messages, which are identical to messages and predetermined message numbers stored at a user agent inside the two-way messaging network that is associated with the wireless messaging device. The messages may be stored in message tables. *Id.* at 5:33-41, 5:62-64. The wireless messaging device can originate new messages, or reply to previously received messages by sending a coded message to a corresponding user agent inside the two-way messaging network. The coded message includes a message number that "uniquely identifies a message stored both locally at the device and at the user agent," *id.* at 1:62-2:3, and a "short group identifier," *id.* at 5:37-38. LaPorta discloses that the address and message information stored in the messaging device and respective user agent are maintained to be consistent with each other. *Id.* at 5:62-6:3.

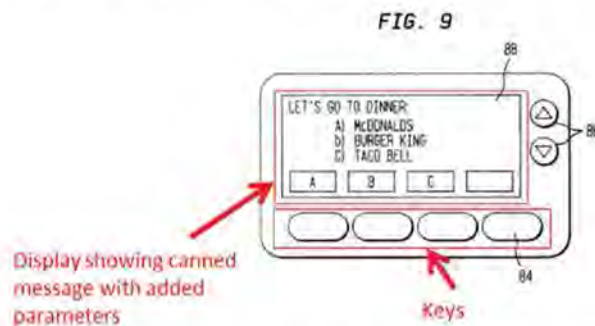
FIG. 1



76. Based on the above teaching of LaPorta and in view of my education and experience, it is my understanding that, a person of ordinary skill in the art at the time of filing the '506 Patent would have understood that the "message number" described in LaPorta correspond to the message codes described in the '506 Patent. One of ordinary skill in the art would have also understood that the "message tables" described in LaPorta correspond to files of canned messages and associated message codes. Furthermore, a person of ordinary skill in the art would have understood that LaPorta teaches that the tables or files of canned messages and message numbers that are maintained at the messaging devices and the associated user agents are identical to each other, and that the system can perform actions to maintain these tables consistent across all the devices. See, e.g., ¶179 below.
77. LaPorta describes that when the user agent receives a coded message from the originating messaging device, the user agent expands the message back to the desired full message by selecting from the messages stored at the user agent, *id.* at 2:5-12, for forwarding to the destination messaging device. The user agent uses the message number and the short group

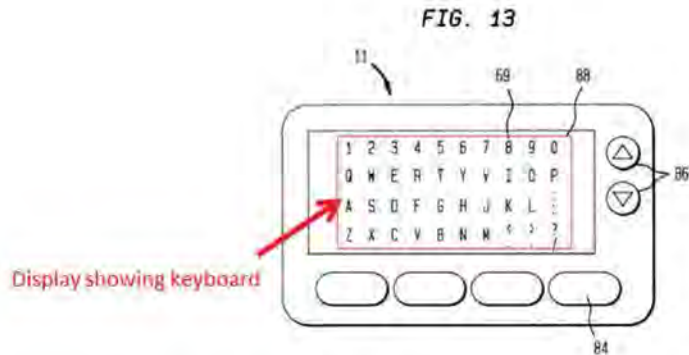
identifier included in the message received from the originating device as indices to look up respective data tables for message expansion. *Id.* at 5:38-40. The selected destination may be a second two-way messaging device. *Id.* at 4:57-59. See also Annotation 1 of Fig. 1 (reproduced above).

78. Providing an example of a messaging device, LaPorta describes that the messaging device can be a dedicated, two-way pager 11, as illustrated in Fig. 9 (annotated below), which “generates, receives and displays messages to the subscriber user.” *Id.* at 8:38-39. LaPorta discloses that the messaging device includes four function buttons 84 that serve as “soft keys, i.e. keys whose functions vary with the contexts.” *Id.* at 8:47-48. Among other components, the messaging device also includes a 5-line LCD screen 88 in which the top four lines are used for text. The pager includes computing hardware, e.g., a processor and memory for user interface code and pager protocol. The memory stores various messages and associated data. *Id.* at 8:50-57.



79. LaPorta discloses that the messaging device can also include a simulated keyboard displayed on the LCD screen of the device, as illustrated by Fig. 13 (annotated below). A subscriber can use the simulated keyboard to compose messages. *Id.* at 6:8-12. Additionally or alternatively, a subscriber can connect the messaging device, using an input/output port of the device, to a laptop or a personal digital assistant (PDA) to edit messages. *Id.* at 6:23- 28.



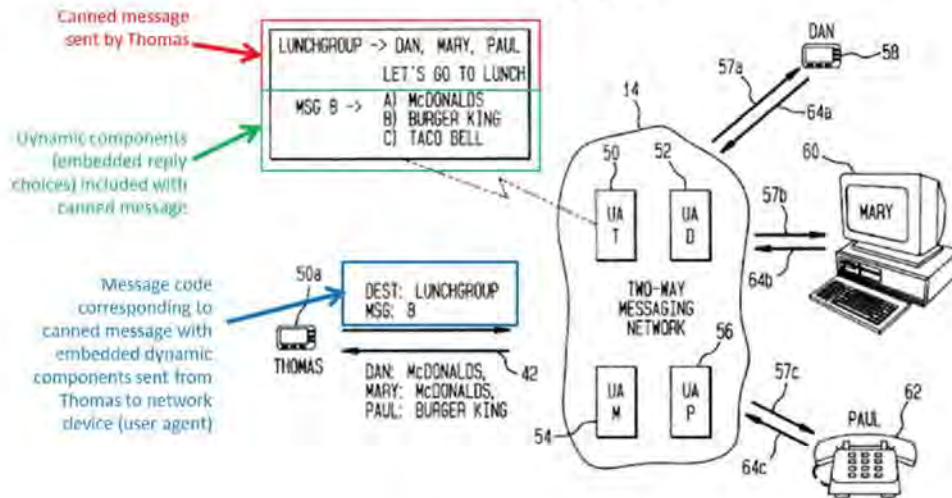


80. Based on the above teaching of LaPorta and in view of my education and experience, it is my understanding that, a person of ordinary skill in the art at the time of filing the '506 Patent would have understood that either or both of the originating and destination messaging devices described in LaPorta may include a two-way pager 11. One of ordinary skill in the art would have also understood that the memory included in the pager 11 that "should be adequate enough to contain these various messages and associated data." *Id.* at 8:56-57, correspond to memory that stores the tables of canned messages and the associated message numbers. Furthermore, one of ordinary skill in the art would have understood that the processor included in the pager 11 can retrieve the canned messages and associated message numbers from the tables stored in the memory of the pager, and display the retrieved canned messages to the user of the pager using the LCD screen 88.
81. Providing a description of a user agent, LaPorta describes that a user agent 12, illustrated in Fig. 11 (reproduced below), can include some fixed functionality, such as registration/deregistration, message delivery and message status query, which are common across all user agents. The user agent also includes a database 73, and software 74 that is "associated with the user agent program to provide run time support for the system." *Id.* at 7:3-7, 7:14-19. The user agent also includes user agent program modules 72a, 72b in which additional functions can be added to customize the user agent for the associated messaging device. *Id.* at 7:11-14, 7:52-62.
82. Based on the above teaching of LaPorta and in view of my education and experience, it is my understanding that, a person of ordinary skill in the art at the time of filing the '506 Patent would have understood that the user agent disclosed in LaPorta may include a network device that is

- associated with a messaging device, which may include a message originator. One of ordinary skill in the art would have also understood that LaPorta further teaches that the user agent can be associated with a destination messaging device. The originating messaging device can send a canned message using the associated message number to its respective user agent, which forwards the corresponding message to the user agent of the destination messaging device for sending to the destination.
83. LaPorta further discloses that the originating messaging device can customize the message to be transmitted by adding parameters or dynamic components such as embedded replies, choices, predefined variables" to the fixed pre-canned components of the message. *Id.* at 2:13-27. "The dynamic components allow customization of messages by message senders and recipients, thus greatly increasing the practical applicability of the system. The particular values of the dynamic components are encoded in the message modifier, and are recovered and applied by the user agent." *Id.* at 2:22-24. LaPorta elaborates that the dynamic components can include selections and predefined variables. "For example, a selection labeled "location" may expand into the list of choices: a) home, b) office, or c) lab. The set of available selections are defined by the individual subscribers. Pre-defined variables represent specific commonly used entries that can be customized by a user. Typical examples of pre-defined variables are time, phone number, etc." *Id.* at 13:24-37. LaPorta further discloses that "[d]ynamic components can be nested as needed," 13:37-38.
84. LaPorta describes that the originating messaging device can add reply components to a message to facilitate a reply. "A reply component embeds the desired replies, typically making use of dynamic components. This is useful in applications where the possible replies are agreed upon a priori." *Id.* at 13:39-43.
85. The reply components can include multiple reply choices or options. Providing an example of a message that is customized by embedding both reply choices and predefined variables, LaPorta describes a stock trading application, in which "[a] subscriber is notified via two-way messaging when a stock he or she is interested in has reached a particular value. The notification message can embed a reply with choices to buy or sell and predefined variables for entering the number of shares and share price." *Id.* at 2:16-21.

86. LaPorta teaches that when a message is customized using reply choices, or other parameters such as predefined variables, or both, the destination messaging device can select from one of the reply choices and send a response to the origination messaging device that includes the selected reply choice. *Id.* at 5:15-29, 5:55-61. The reply that is sent by the destination messaging device is also a coded message that includes an identifier to associate it with the original message. 15:34-37.
87. LaPorta discloses that using customized messages that include dynamic components and/or reply components, the system can track and answer queries about transactions, where a transaction is "a single or a series of request-response interactions between a message sender and recipient(s)." *Id.* at 2:45-48. LaPorta explains that "[a] transaction is most useful for communication scenarios in which selective responses are desired." *Id.* at 2:48-50.
88. LaPorta provides an example of a transaction by describing, with reference to Fig. 3, a message exchange between four users, each of whom has a user agent associated with respective messaging devices. LaPorta describes that a user Thomas sends a message through his pager 50a to his lunch group members, Dan, Mary and Paul, and inquire about lunch choices. *Id.* at 5:12-26. As illustrated by Annotation 1 of Fig. 3 below, Thomas sends the message as a pre-canned message, with the inquiry about lunch choices sent as an embedded response. The embedded response includes a list of responses from which each of the recipients can select. The originating messaging device can display the response options for Thomas to select. *Id.* at 5:55-61.

FIG. 3

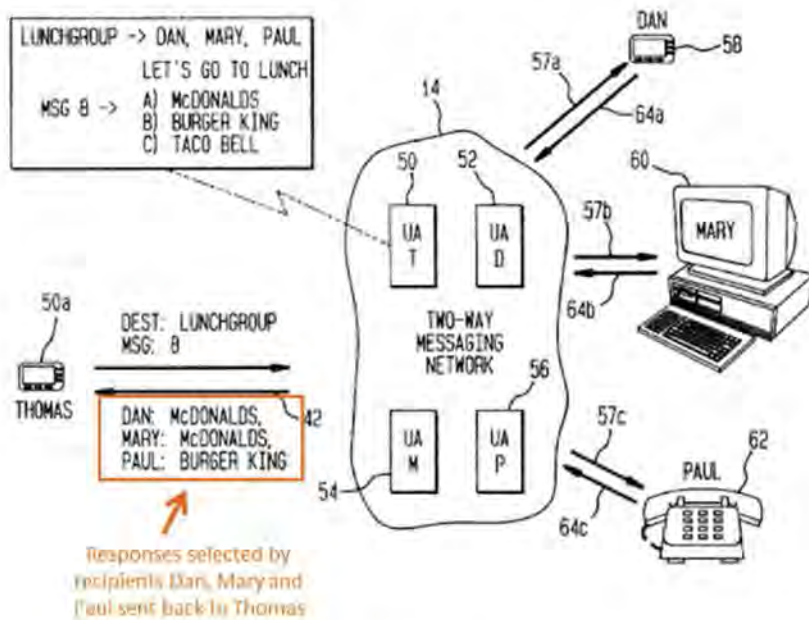


Annotation 1

89. Thomas sends the message number corresponding to the selected pre-canned message to the user agent associated with his messaging device, along with the embedded list of responses. The user agent looks up the corresponding message based on the message number, and forwards the expanded message with the response options to each recipient. As shown by Annotation 2 of Fig. 3 below, the responses that are selected by the recipients are sent back using reply codes, which are forwarded to Thomas as a full reply. *Id.* at 5:33-47.
90. Based on the above teaching of LaPorta and in view of my education and experience, it is my understanding that, a person of ordinary skill in the art at the time of filing the '506 Patent would have understood that LaPorta teaches that the reply choices themselves can be canned replies with corresponding reply codes. When a destination messaging device receives a canned message with embedded reply choices, the destination device displays the list of response options to the recipient, who can select one of the reply choices. The recipient can also enter values for predefined variables that may be included as part of the reply choices. Based on the user selection, the destination messaging device selects a reply code corresponding to the selected

reply option and sends the selected reply code to the originating messaging device. If predefined variables are also included, the destination messaging device sends the user-entered value for the predefined variable along with the selected reply code. See, e.g., ¶¶93-94 and Annotations 1 and 2 of LaPorta Fig. 3.

**FIG. 3**



**Annotation 2**

91. A person of ordinary skill in the art at the filing date of the '506 Patent would have combined Cannon with LaPorta at least for the reasons discussed below. Based on the teachings of Cannon and LaPorta as outlined above, a person of ordinary skill in the art, at the filing date of the '506 Patent, would have readily appreciated that the two references provide teachings in similar fields of endeavor. Both describe communications systems that provide two-way messaging for portable messaging units or wireless messaging devices. The two references also describe how the communication may be performed using canned messages, where shorter message aliases or

message numbers corresponding to the canned messages are transmitted over the communications channels, instead of sending the messages in full.

92. A person of ordinary skill in the art would have combined the teachings of Cannon with the teachings of LaPorta to send frequently transmitted information that are customized with added parameters, where the customized messages are communicated using shorter message aliases from a source messaging device to a receiving device through a network system controller, as taught by Cannon. In more detail, Cannon teaches that portable messaging units (PMUs) communicate frequently transmitted messages using "relatively short" message aliases, APL-1004 at 2:21, that are communicated through an intermediate system controller, *see, e.g., id.* at 2:19-32, 9:38-53 and 5:3-9, where the source and recipient PMUs and the system controller each stores databases of the frequently transmitted messages and the associated aliases, *see, e.g., id.* at 6:46-57. However, Cannon is silent about sending messages that are customized with added options, *e.g.,* reply choices or other parameters such as predefined variables, such that the options are sent along with the message aliases. This is taught by LaPorta, which discloses that the message originator can customize the message by adding "dynamic components such as embedded replies, choices, pre-defined variables, etc." to the "fixed pre-canned components." APL-1005 at 2:13-21. The originator sends "particular values of the dynamic components [] encoded in [a] message modifier," *id.* at 2:25-27, that "represents the customization to be applied to the [coded] message," *id.* at 2:3-4. The user agent recovers the dynamic components based on the message modifier, and applies to the pre-canned components to customize the message that is delivered to the recipient. *See, e.g., id.* at 2:26-27. The full message with the added customizations is delivered to the recipient, who can select from the reply choices or enter values for the predefined variables, as applicable, and respond to the message originator. *See, e.g., id.* at 2:13-25.
93. One of ordinary skill in the art would have augmented sending frequently transmitted information using relatively short message aliases, as taught by Cannon, by adding LaPorta's dynamic components to such messages to achieve the flexibility contemplated by LaPorta. *See, e.g., id.* at 2:13. As LaPorta explains, the dynamic components would have allowed message senders and recipients to customize messages, "thus greatly increasing the practical applicability of the system." *Id.* at 2:22-24. Applying LaPorta's dynamic components to Cannon's end-to-end message

- transfer using aliases would have allowed the communicating parties to establish a request-response interaction, where the customized messages are communicated end-to-end using the shorter message aliases.
94. Cannon's communication system may use LaPorta's dynamic components by storing, at each of the originating and recipient PMUs and the system controller, lists of frequently transmitted messages and associated aliases, along with lists of predefined dynamic components and associated values. The originating PMU may customize the frequently transmitted message that is sent by adding a value for the selected dynamic component to the message alias that is sent to the system controller, as taught by LaPorta, *see, e.g., id.* at 2:25-27, which forwards the message alias to the recipient, as taught by Cannon, *see, e.g., Cannon* at 9:46-53, along with the dynamic component value. The use of dynamic components would also allow Cannon's PMUs and the system controller to store smaller lists of the frequently transmitted messages, since the sets of frequently used messages and dynamic components would be less than possible variations based on permutations and combinations of the set of frequently used messages with the set of dynamic components.
95. Furthermore, a person of ordinary skill in the art at the filing date of the '506 Patent would have combined Cannon and Will with LaPorta at least for the reasons discussed below. Based on the teachings of Cannon, Will and LaPorta as outlined above, a person of ordinary skill in the art would have readily appreciated that the three references provide teachings in similar fields of endeavor. All three references describe communications systems that provide two-way messaging for portable messaging units or wireless messaging devices. The references also describe how the communication may be performed using canned messages and/or canned responses, where shorter message aliases (also referred to as message numbers or codes in the different references) corresponding to the canned messages and/or canned responses are transmitted over the communications channels, instead of sending the messages in full.
96. As discussed in §III above, the combination of Cannon and Will discloses communicating messages with response options using message aliases and response codes. *See* ¶¶69-73. However, the two references do not teach that messages can be customized further by adding other parameters, such as predefined variables. This is taught by LaPorta, who describes that

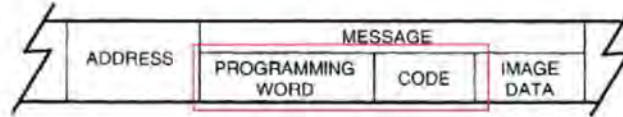
that the originator can customize the message by adding "dynamic components such as embedded . . . choices, pre-defined variables, etc." to the "fixed pre-canned components." APL-1005 at 2:13-21. Moreover, while Will overtly details that the response options are furnished to the recipient with the message (or an alias thereof, per the Cannon/Will combination), see, e.g., Will at 13:66-14:13, 26:38-41, 12:47-13:1, LaPorta enables the addition of other parameters such as "choices, pre-defined variables, etc.," LaPorta at 2:16-17, to be sent along with the message (or its alias), One of skill in the art at the filing date of the '506 Patent would be motivated to augment the communication of messages with response options using message aliases and response codes, as taught by the combination of Cannon and Will, with the "dynamic components such as embedded . . . choices, predefined variables," *id.*, as taught by LaPorta. This would allow Cannon's originating and destination PMUs to exchange messages related to a transaction, i.e., a request-response interaction in which the recipient sends back a selected response option along with values that are entered to further qualify the selected response option. The originating PMU sends a message that includes frequently transmitted information with response options using the associated alias and corresponding response codes, which are forwarded to the recipient by the system controller. The message also includes predefined variables for the recipient to enter additional information when selecting a response option.

97. For example, the originator's message seeks inputs for weekend activities, providing several response options including going to see a movie or a rock concert. For the movie response option, the message may include as a predefined variable or parameter names of several movies, enabling the recipient to select one of these. Alternatively, the message may include as a parameter a field for the recipient to specify the preferred day and time for the selected weekend activity. The recipient's messaging device sends back a code corresponding to the selected response option, along with the entered value of the parameter. The parameter value may be embedded as part of the response code sent back to the originating messaging device. In some implementations, there may be multiple such parameters that are included as part of a request-response interaction. Shorter codes may be associated with the parameters themselves, similar to the message codes or response codes. When the recipient sends a response to the originating messaging device, specifying values for some or all of the parameters that were included in the original message, codes corresponding to such parameters are sent back along with the recipient-specified values.



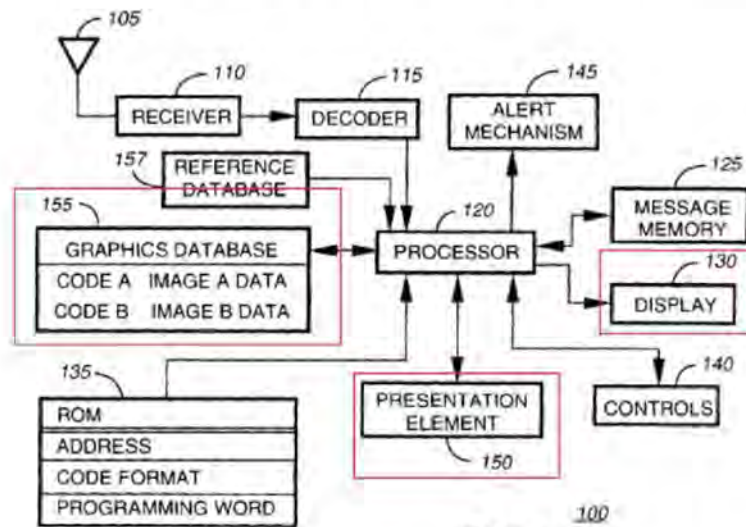
## V. DISCUSSION OF DELUCA AND COMBINATION WITH LAPORTA AND WILL

98. I have been asked to consider whether the '506 Patent, or any of the prior art references, covers canned messages that may be in graphical form, e.g., an Emoji (e.g., a smiley face), where the canned messages are stored with corresponding message codes, such as “:-).”
99. Based on the teaching of the '506 Patent and in view of my education and experience, it is my understanding that, a person of ordinary skill in the art at the time of filing the '506 Patent would not have considered a graphical image, such as an Emoji, to be a canned message. As discussed in ¶32 above, a broadest reasonable interpretation of a “canned message” would be broad enough to cover a “predefined sequence of characters.” It is my opinion that an image, such as an Emoji, cannot be considered to be such a predefined sequence of characters. Also, as discussed previously in ¶¶22-25 and illustrated by Figs. 3 and 4 (reproduced and annotated above), the '506 Patent discloses that a canned message is transmitted from a calling terminal 10 to a receiving terminal 14 either in code form or in text form. Accordingly, the receiving party terminal 14 receives the canned message in either text form or code form, and the canned message is displayed in text form for viewing by the receiving party terminal. An image, such as an Emoji, is not text that is displayed in text form.
100. For at least the above reasons, a graphical image, such as an Emoji, cannot be considered to be a canned message. Accordingly, it is my understanding that Emojis have nothing whatsoever to do with the invention of the '506 Patent. Nevertheless, Deluca discloses messages that include graphic images, and accordingly I describe the applicable portions of Deluca in the appropriate sections below. It is not my opinion, however, that Deluca applies under the proper interpretation of the '506 Patent.
101. In general, Deluca discloses a communications system that includes a paging terminal and a data communication receiver. APL-1011 at 1:14-17. The paging terminal transmits, to the data communication receiver, codes corresponding to messages selected by the message originator. *Id.* at 1:16-17, 2:46-57. The paging terminal includes memory for storing messages until transmission, and includes an encoder for encoding messages for transmission. As shown by Fig. 12 (reproduced and annotated below), the message sent by the terminal includes “a code, either existing or new.” *Id.* at 5:15-62.



**FIG. 12**

102. As illustrated in Fig. 1 (reproduced and annotated below), Deluca discloses that the data communication receiver includes a database for storing image data associated with the messages that are transmitted by the paging terminal and corresponding codes, *see, e.g., id.* at 3:1-7, such that the receiver can recover the graphic image associated with a message sent by the originator based on the code received from the paging terminal, *see, e.g., id.* at 4:33-60.



**FIG. 1**

103. As discussed above, Deluca discloses that the paging terminal transmits to the receiver a code corresponding to a message selected by the message originator. *Id.* at 2:46-57. Deluca teaches that the paging terminal encodes the messages for transmission using an encoder and transmits the encoded message as a radio signal using a transmitter. *Id.* at 5:18-22, 5:33-37.

104. Describing the operation of the receiver, Deluca discloses that the receiver receives a predetermined code from the call terminal, and obtains the message associated with the code from the database that stores image data associated with the messages and corresponding codes. *Id.* at 2:42-46, 2:54-60. Deluca discloses that the receiver includes a presentation element, *see* Fig. 1 (reproduced and annotated above), which processes each received message and retrieves the image data associated with the received code from the database stored in the receiver. *Id.* at 4:33-46 and 4:52-60; *see also* Deluca Fig. 10 (reproduced and annotated below).

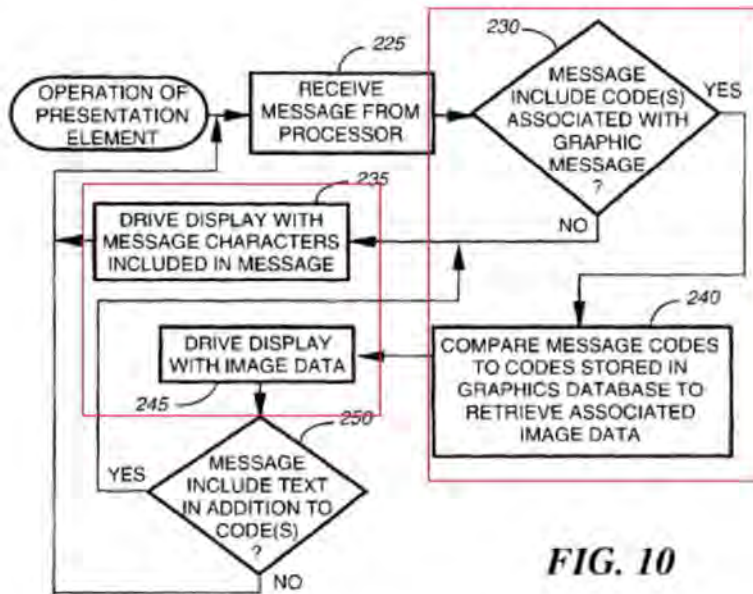
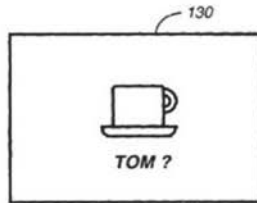


FIG. 10

105. Deluca discloses that the data communication receiver display the message corresponding to the message code that is received from the call terminal on "a display 130, such as a liquid crystal display" that is part of the receiver and "coupled to the processor 120 for presenting information to the user." *id.* at 2:37-39, 2:57-60, 4:56-59, 7:43-47. *See also* Fig. 1 (annotated above).
106. Deluca further discloses that the messages that are transmitted can be supplemented by "additional textual information presented substantially coincident with the graphic messages." *id.* at 3:51-61, such that the information corresponding to the transmitted message that is displayed to the receiver includes an image along with text, *id.* 4:1-18. *See also* Fig. 8 (reproduced below).



**FIG. 8**

107. Based on the above teaching of LaPorta and in view of my education and experience, it is my understanding that, a person of ordinary skill in the art at the time of filing the '506 Patent would have understood that the data communication receiver described in Deluca can be a two-way pager. One of ordinary skill in the art would have also understood that, under MTel's apparent interpretation of claims 8, 19 or 21, the messages that are stored in the database at the receiver can be canned messages, and the codes transmitted by the paging terminal can be message codes corresponding to the canned messages. Furthermore, one of ordinary skill in the art would have understood that the paging terminal disclosed in Deluca is a network device that sends message codes corresponding to canned messages to the receiver.
108. A person of ordinary skill in the art at the filing date of the '506 Patent would have combined LaPorta with Deluca at least for the reasons discussed below. Based on the teachings of LaPorta and Deluca as outlined above, a person of ordinary skill in the art at the filing date of the '506 Patent, would have understood that, under MTel's apparent interpretation of claims 8, 19 or 21, the two references provide teachings in similar fields of endeavor. Both describe communications systems that provide messaging for wireless messaging devices. The two references also describe how the communication may be performed by transmitting shorter message codes corresponding to longer messages selected by the source, where an intermediate network node is involved in forwarding information to the destination.
109. A person of ordinary skill in the art would have combined the teachings of LaPorta with the teachings of Deluca, applying MTel's apparent interpretation of claims 8, 19 or 21, to extend LaPorta's mechanism of sending shorter message numbers corresponding to a message end-to-end from the originating messaging device to the recipient messaging device, where the shorter message number is relayed through an intermediate network node, e.g., an user agent, as

taught by LaPorta. In greater detail, LaPorta describes that an originating messaging device communicates messages to a destination by sending, to a user agent, a predetermined message number corresponding to a message that is stored both at the originating device and the user agent. See, e.g., APL-1005 at 1:62-2:4. The user agent expands the coded message received from the originator back into the full message, and forwards the full message to the recipient. See, e.g., *id.* at 2:8-12. However, even though LaPorta teaches that the "destination could be a second two-way messaging device," *id.* at 4:57, LaPorta does not explicitly disclose that the user agent can forward the shorter message numbers to the receiving device. This is taught by Deluca, which discloses that the paging terminal transmits, to the data communication receiver, codes corresponding to messages selected by the message originator. APL-1011 at 1:16-17, 2:46-57. The receiver includes a database for storing image data and associated codes corresponding to the messages that are transmitted by the paging terminal, *id.* at 3:1-7, such that the receiver can recover the message sent by the originator based on the code received from the paging terminal, *id.* at 4:33-60.

110. One of ordinary skill in the art would have augmented LaPorta's data transmission mechanism using message numbers by applying Deluca's teaching to extend the transmission of the message numbers all the way to the recipient, instead of limiting the message number transmission from the originating device to the intermediate network node. Each of the originating and recipient message devices, and the associated user agents, can store predetermined messages along with corresponding message numbers or codes. The originator sends, to its associated user agent, the message number corresponding to the desired predetermined message to be conveyed to the recipient. The originator's user agent forwards the message number to the recipient's user agent, instead of expanding the message number to the full message for sending to the recipient. The recipient's user agent in turn forwards the message number to the recipient, which retrieves the full message from its memory based on the received message code.
111. Furthermore, a person of ordinary skill in the art at the filing date of the '506 Patent would have combined LaPorta and Deluca with Will, under MTel's apparent interpretation of claims 8, 19 or 21, at least for the reasons discussed below. Based on the teachings of LaPorta, Deluca and Will as outlined above, a person of ordinary skill in the art would have readily appreciated that the three references provide teachings in similar fields of endeavor. All three references describe

- communications systems that provide messaging for wireless messaging devices or receivers. The references also describe how the communication may be performed by sending codes corresponding to messages selected by the originating messaging device, where the codes are transmitted over the communications channels, instead of sending the messages in full.
112. As discussed in ¶¶108-110 above, the combination of LaPorta and Deluca discloses that message numbers or codes corresponding to messages may be communicated end-to-end from the originating messaging device to the recipient messaging device, where the shorter code is relayed through an intermediate network node, e.g., a user agent. LaPorta further discloses that the message originator can customize the message by adding "dynamic components such as embedded replies, choices, pre-defined variables, etc." to the "fixed pre-canned components." See, e.g., APL-1005 at 2:13-21. These dynamic components can include reply choices, see, e.g., *id.* and *id.* at 13:39-41, for selection by the recipient, see, e.g., *id.* at 5:58-61. However, the combination of LaPorta and Deluca does not explicitly describe how a recipient may select a reply choice and send a response to the originator. This is taught by Will, who explicitly describes that responses added to a message by a sender are displayed to the recipient, who can select from one of these responses. See, e.g., APL-1006 at 17:58-62 and 12:47-13:1. Will describes that the response options are forwarded by the central station to the receiving device along with the messages. *Id.* at 13:66-14:5. The response options can include preprogrammed responses that are stored at the receiving device, such that codes corresponding to the response options can be forwarded along with the message. *Id.* at 14:14-18. The response options can be displayed to the receiving user on the receiving devices display, see, e.g., *id.* at 26:30-50. The receiving user can select from one of these response options, *id.* at 26:40-58, and a response code corresponding to the selected response option can be transmitted from the receiving device to the central station, *id.* at 12:47-13:1. In doing so, Will provides a detailed example how a receiver can select one of the embedded reply choices in messages that are sent by the originator, as taught by LaPorta.
113. One of ordinary skill in the art at the filing date of the '506 Patent would have been motivated to augment LaPorta and Deluca's teaching of sending codes corresponding to desired messages with embedded reply choices from the originator to the receiving device message, with reply codes corresponding to the reply choices, as taught by Will. Sending reply codes instead of the actual

reply options will further reduce the network bandwidth that is used for message transmission, thereby improving delivery times. LaPorta and Deluca, teach sending message codes, where the predetermined messages and associated codes are stored at the originator and recipient devices and the intermediate network nodes. In implementing Will's teaching, the originator and recipient devices and the intermediate network nodes can also store the response options and the associated response codes.

## VI. CONCLUSION

114. I hereby declare that all statements made herein of my own knowledge are true and that all statements made on information and belief are believed to be true; and further that these statements were made with the knowledge that willful false statements and the like so made are punishable by fine or imprisonment, or both, under Section 1001 of Title 18 of the United States Code.

Respectfully submitted,

June 27, 2014

/Rajeev Surati/

Date: \_\_\_\_\_

\_\_\_\_\_  
Rajeev Surati, Ph.D.

## Curriculum Vitae

**Rajeev Surati Ph.D.**

62 Putnam Ave  
Cambridge  
MA, 02139

Tel: +1 508 472 5319

E-mail: [raj@alum.mit.edu](mailto:raj@alum.mit.edu)

**Profile:**

I am an MIT Ph.D. trained technologist in Electrical Engineering and Computer Science and a serial entrepreneur. I am looking to work on what I love doing – writing software and building solutions to problems in a stable environment that appreciates technical excellence, innovation and perseverance. I have a broad academic, practical, and business-related knowledge base having patented and/or invented and implemented several basic technologies from the ground up. I have subsequently formed and sold companies based on these technologies to Microsoft, and other technology companies. The technologies mentioned above are related to the internet, compilers, computer graphics, machine vision, displays, instant messaging, projector camera systems, publish-subscribe systems, photo-sharing, social-networking etc. I am known as a very creative, patient, and determined problem solver and I love mathematics and physics almost as much. I am easy to get along with and love to work and focus on problems people want to solve. Figuring out which problem to solve is also something I like to do in the form of listening to customers/users and providing directed program/product management etc.

---

**Education:**

**Massachusetts Institute of Technology** SB, 1992, SM, 1995, Ph.D.1999  
GPA: SB 4.9/5.0 SM: 5.0/5.0 Ph.D. 5.0/5.0 all In Electrical Engineering and Computer Science

SB Thesis: *A Parallelizing Compiler Based on Partial Evaluation* – Dept. Thesis Prize (later)  
–*Early Days of How to fill Floating Point Pipelines*  
SM Thesis: *An Object System Based on Partial Evaluation*  
–*Getting Good Computation Throughput – with Abstraction*  
Ph.D. Thesis: *Scalable Technology for Large Scale Seamless Displays*  
–*Making Massive Resolution Display a Reality*

**Employment:**

**Scalable Display Technologies**

1/2004 – Present

**Position:** President, Chairman, and Co-Founder

World's leading provider of technologies to build and maintain seamless tiled large displays. Core technology in auto-calibration of large displays. Technology is based on my Ph.D. thesis and seminal projector camera patents filed while at MIT in 1998. I developed the basic technology on C/C++ and Window. Then I program/product managed our relationships and software architecture integrating it with NVIDIA, AMD, NEC, Sony, etc. I also designed an SDK for integration with over 50 Image Generators. Systems of interest: 100 megapixel dome for AFRL, 200 Megapixel eye-limited resolution display for Air Force research on Pilots, 140 Megapixel Holodeck – releasing this summer at Brown university, 20 megapixel seamless display for Gigapixel Camera Surveillance System, NVidia Warp and Blend API for Quadro, AMD DOPP architecture for post render warp and blend. Technologies: C++, .net, java, Open GL, Direct X, TCP-IP, DirectShow, rs-232, etc.

**Photo.net.**

7/2000-May 2007

**Position:** President, Co-Founder, Chairman

Turned world's largest and best amateur photographer site from a simple forum site into a viable growing community based business along with Philip Greenspun. Ran a preLAMP stack based on AOLServer, tcl, and Oracle 9 with innovative features such as: photo-sharing, click through advertising, digital subscriptions for vanity purposes etc. We had very limited resources in 2000 when the dotcom winter hit and I had to start afresh with a single machine in a new data centre. Thus, I had to scale the site with limited funds, and very careful software optimization. Thus I bought hardware only when I could no longer optimize and ultimately



ended up with a rack of equipment: load balancers, RAID System etc.

**Microsoft** 7/1999 - 7/2000  
**Position:** Software Development Engineer

Worked on Exchange 2000 IM Server and MSN Messenger.  
Wrote patents on publish-subscribe architectures etc. Position created post sale of Flash Communications Wrote in C++, used COM etc. XML etc.

**Flash Communications** 2/1997 – 02/1998  
**Position:** CTO, Co-Founder  
Company sold to Microsoft, prior to finishing my PhD thesis.

**Oak Ridge National Lab**  
**Position: Summer Intern**  
Spectroscopy Group building Lab-on-a-Chip.

**MIT AI Lab** 9/1992 – 6/1998  
**Position: Research Assistant**  
Worked with world renowned computer scientists: Thomas F. Knight, Gerald Jay Sussman, and Hal Abelson on a wide variety of projects. Helped build an early VLIW computer architecture with HP and mainly designed a special software compilers that did register allocation, parallelization to fill floating point pipeline. I also worked on camera feedback based projector systems, and on projects in the early days of the web: HTTP, TCP, UDP, database backed web systems etc.

**Naval Research Labs**  
**Position: Summer Intern**  
Worked on wavelet decomposition and classification based on said decomposition of radar return signal in C/C++. Wrote visualization tools that dramatically improved the investigative cycle time. Lots of hacking with postscript to help visualize results.

**Technology Hackers Inc** 6/1992-12/1992  
**Position: Electrical Engineer**  
Built a 512 node 2D array of phased array microphones.

**Microsoft** 6/1988-8/1988, 6/1999-9/1999  
Worked on Microsoft PC Client for Mail, Microsoft File, Microsoft Works (pre Windows).

**Advisory Boards** UnifySquare, Paneve (General Purpose Asic coupled with Compiler Technology), Nexaweb (Realtime Web Application framework using HTTPS), Antix Labs (Compiler Technology for universal gaming platform), Permabit (Content Addressable Storage), Evoque.

**Awards:** Department of Energy Computational Science Graduate Fellow 1995-97, William A Martin Thesis Prize for Best Undergraduate Thesis in Computer Science 1992, Global Indus Technovator Award 2009, Laureate of 2009 Computer World Honors Program, MIT 6.270 Lego Robot 1991 – Robot was named with Nuclear Capabilities on fields of RoboHockey.

16 years of corporate board experience.

---

**Patents:**

6,456,339 Super-resolution display  
6,415,318 Inter-enterprise messaging system using bridgehead servers  
6,260,148 Methods and systems for message forwarding and property notifications using electronic subscriptions  
5,943,478 System for immediate popup messaging across the internet

**Applications:**

20100321382 System and Method for Injection Mapping of Functions  
20080246781 System and Method for Providing Improved Display quality by Adjustment and image processing using optical feedback  
Provisional System and Method for Calibrating a Display System Using Manual and Semi-Manual Techniques.  
Provisional System and Method for Color and Intensity Calibrating a Display System for Practical Usage

**Systems Built (Individually or as part of a team):**

Spambot: One of the Internet's first free to use Mailing List Servers that was database backed  
Photo.net's photo sharing system: One of the first on the internet, and given rave reviews as one of the best systems out in 1999  
Photo.net's mobile WAP interface  
MIT Supercomputing Toolkit: VLIW 8 processor system out of discrete parts  
Microsoft Exchange 2000 IM Server and MSN Messenger Service  
Internet Coke Machine: 1993 – food transfer protocol (modified ftp server hooked up to microcontrolled coke machine)

Skills: C++, C, Scheme, TCL, C#, Java, SQL, dabbled in PERL, python, etc. ], TCP and networking, image processing, firmware programming etc. Did some Oracle DBing for photo.net. Very fast at learning enough to implement what I need done to solve a problem, E&M, machine vision, etc.

**References:** Available upon request.

**Publications:**

Partial Evaluation for Scientific Computing: The Supercomputer Toolkit Experience A. Berlin and R. Surati, Proc of ACM SIGPLAN Workshop on Partial Evaluation and Semantics-Based Program Manipulation, 1994

Exploiting the Parallelism Exposed by Partial Evaluation.  
By: Rajeev J. Surati, Andrew A. Berlin  
In: IFIP PACT, 1994

A Parallelizing Compiler Based on Partial Evaluation, MIT Artificial Intelligence Laboratory Technical Report, TR-1377, July, 1993

**Invited Talks:**

*Ultra High Resolution Displays and Interactive Eye-point Using CUDA* NVIDIA GPU Computing Conference 2010

*Using the GPU to Create Seamless Displays from Multiple Projectors* SIGGRAPH 2011 NVIDIA Presentation.

*Seamless Scalable Displays - Using NVIDIA Warp + Intensity API* NVIDIA GPU Computing Conference 2012

*Using Warp and Blend API in Distributed and Single Renderers / Update on Warping Standards* with Bei Wang (Walt Disney Imagineering), NVIDIA GPU Computing Conference 2013

*Mid-Tier VR: Cost Reducing the Cave by Embracing the GPU* with Bei Wang – Walt Disney Imagineering, NVIDIA GPU Computing Conference 2014

**Teaching:**

MIT Teaching Assistant:  
6.001 Structure and Interpretation of Computer Programs (2 times),  
6.002 Circuits,  
6.013 Electro and Magneto Quasi-static Systems.  
ArsDigita University: Lecturer Probabilistic Systems.



US005850594A

# United States Patent [19]

[11] Patent Number: **5,850,594**

Cannon et al.

[45] Date of Patent: **Dec. 15, 1998**

[54] METHOD AND APPARATUS FOR EFFICIENTLY TRANSMITTING ADDRESSES AND MESSAGES FROM PORTABLE MESSAGING UNITS OVER A WIRELESS COMMUNICATION CHANNEL

[75] Inventors: Gregory Cannon; Nancy Cannon, both of Keller, Tex.

[73] Assignee: Motorola, Inc., Schaumburg, Ill.

[21] Appl. No.: 697,513

[22] Filed: Aug. 26, 1996

[51] Int. Cl.<sup>o</sup> ..... H04B 7/26

[52] U.S. Cl. .... 455/31.3; 455/412; 455/419; 455/458; 340/825.22; 340/825.27; 340/825.44

[58] Field of Search ..... 455/412, 414, 455/415, 417, 458-460, 31.2, 31.3, 32.1, 38.1, 38.4, 564, 517, 419; 340/825.44, 311.1, 825.22, 825.27

### [56] References Cited

#### U.S. PATENT DOCUMENTS

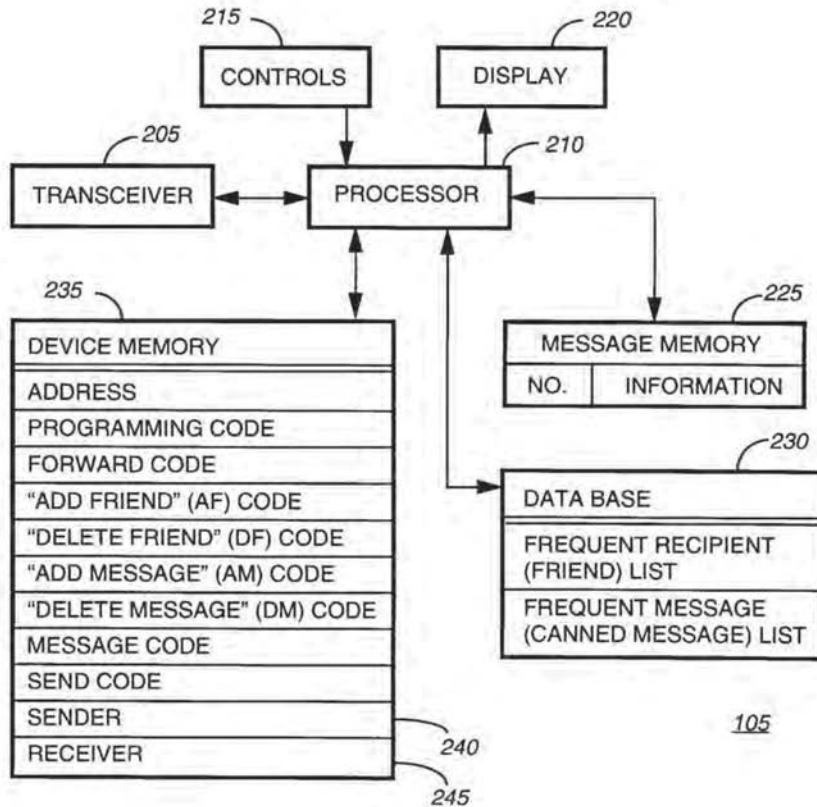
5,066,949	11/1991	Breeden et al.	340/825.44
5,257,307	10/1993	Ise	455/31.3
5,487,100	1/1996	Kane	340/825.44
5,630,207	5/1997	Gitlin et al.	455/38.4

Primary Examiner—Edward F. Urban  
Assistant Examiner—Lee Nguyen  
Attorney, Agent, or Firm—Charles W. Bethards

### [57] ABSTRACT

A communication system (100) for providing two-way communication including a portable messaging unit (105) for sending a signal including a recipient alias over a wireless communication channel and a controller (110) for receiving the signal including the recipient alias. The controller (110) then transmits a message to an address that is designated by the recipient alias and that is longer than the recipient alias.

9 Claims, 9 Drawing Sheets



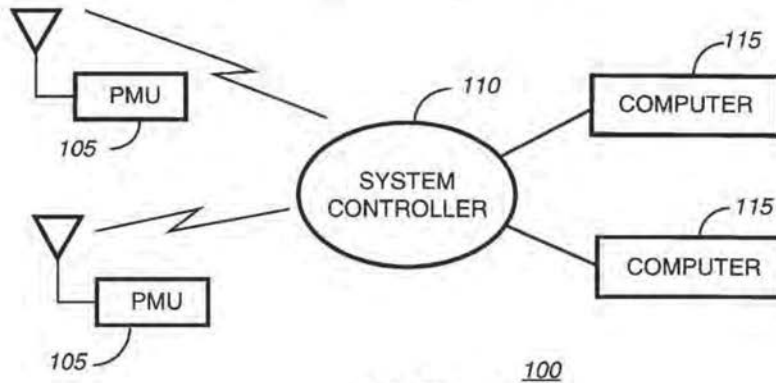


FIG. 1

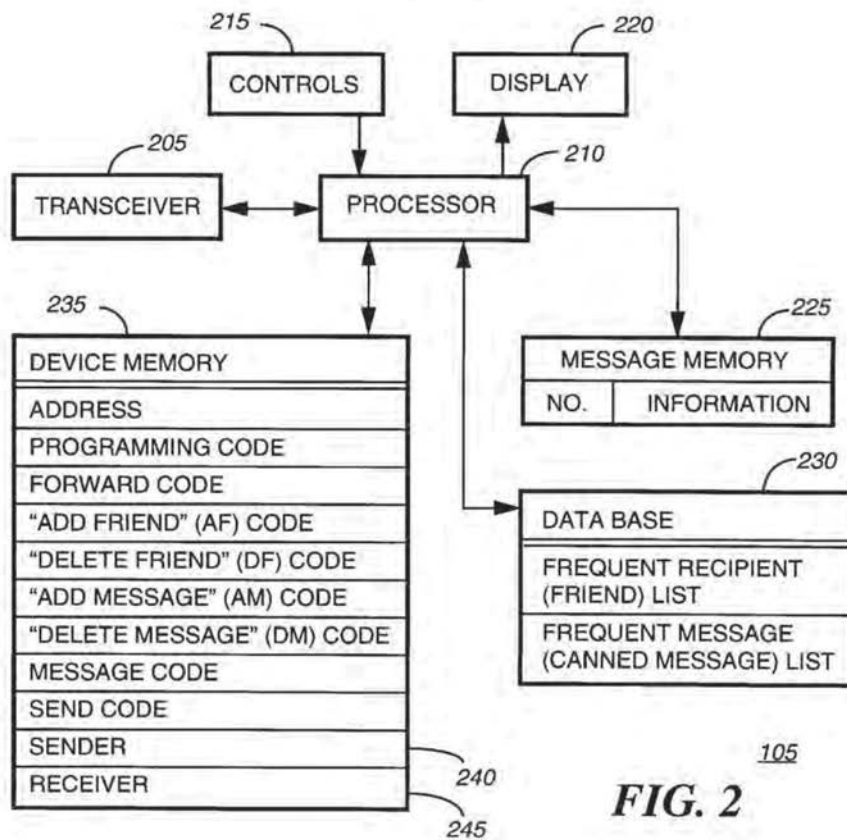


FIG. 2

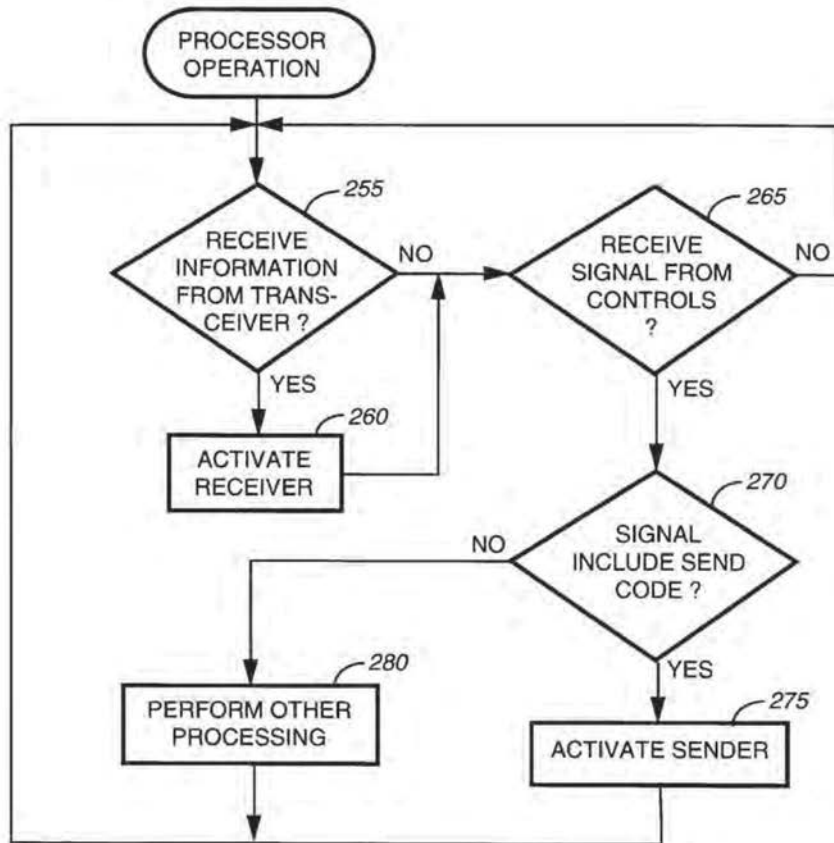


FIG. 3

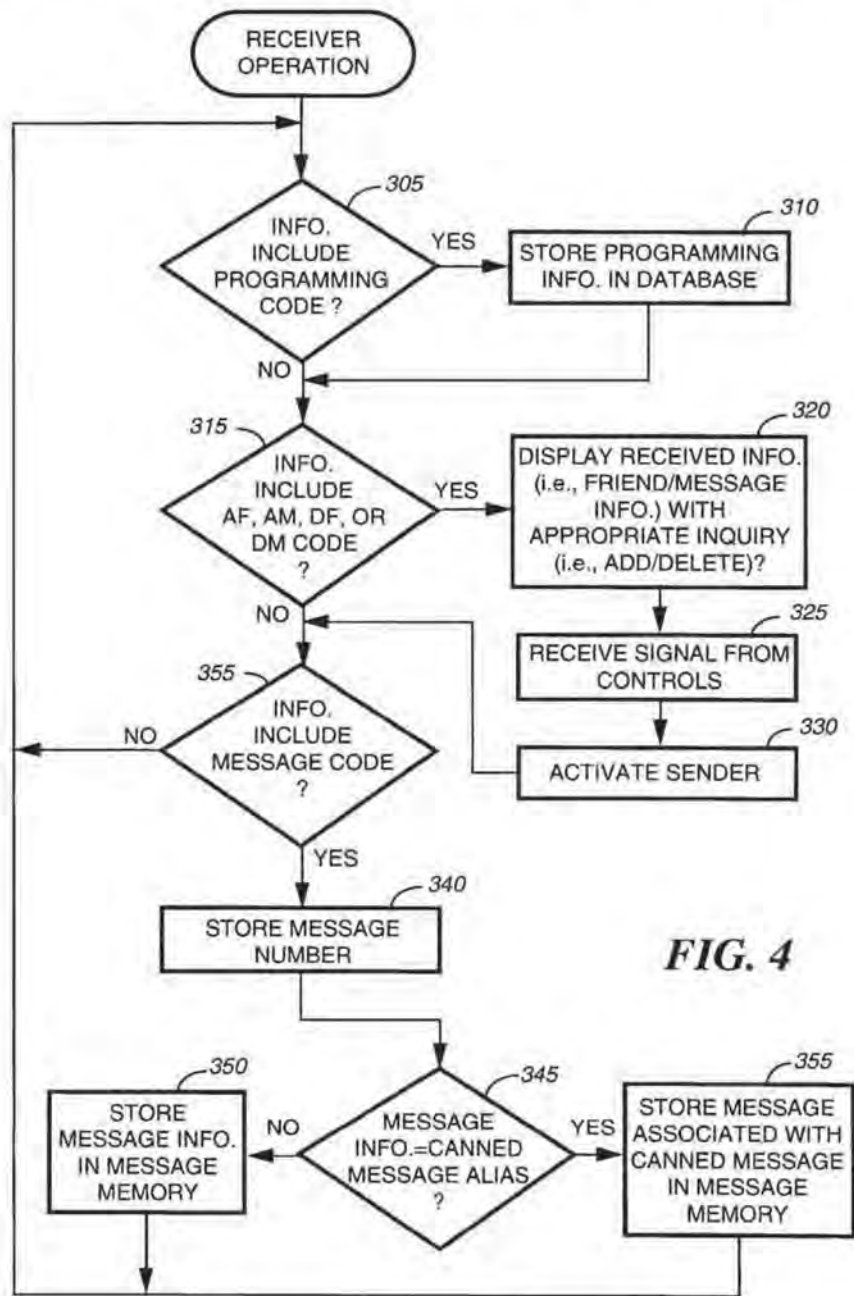


FIG. 4

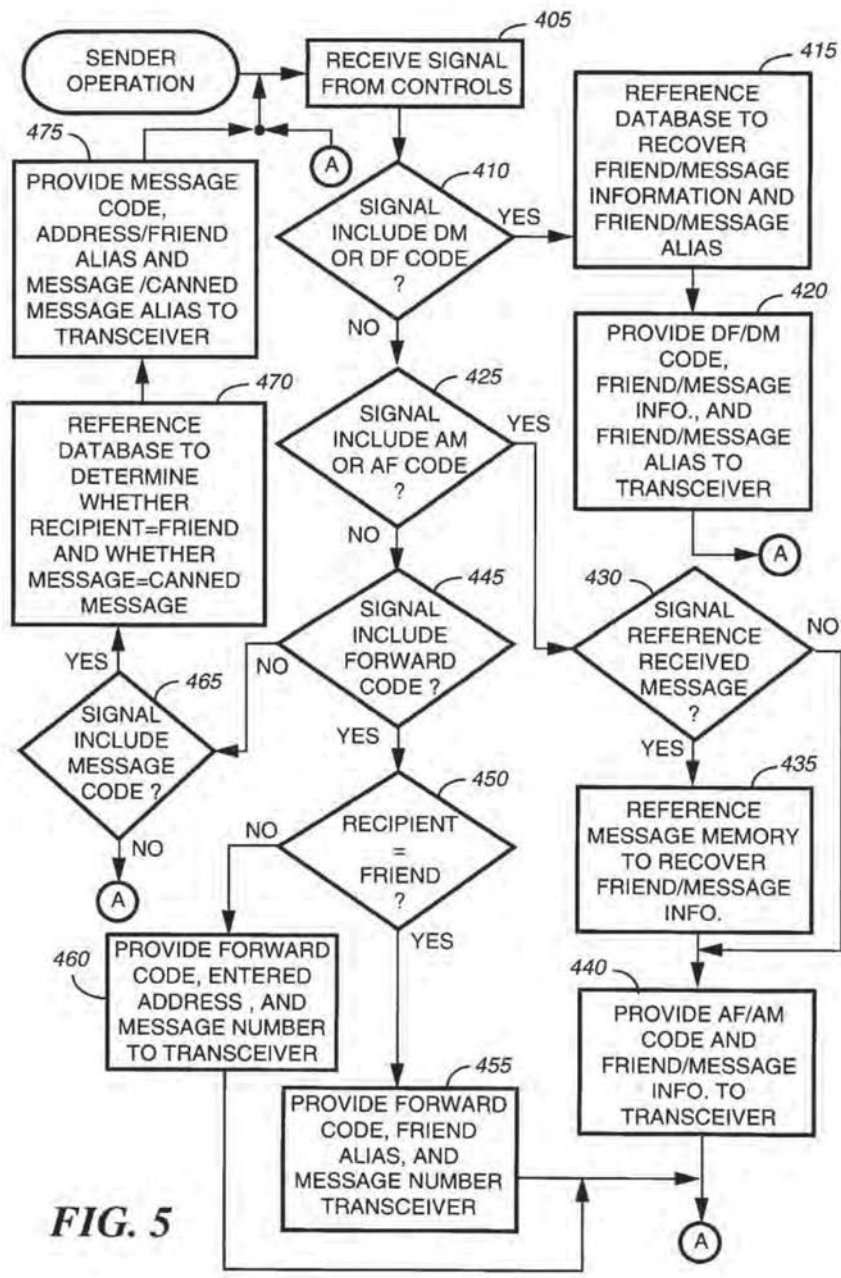
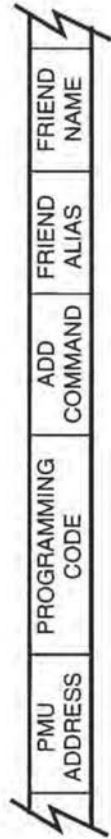


FIG. 5



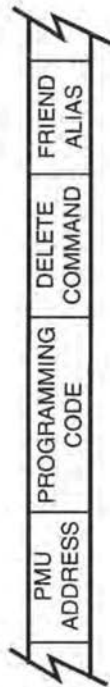
**FIG. 6** PMU→SC



**FIG. 7** SC→PMU



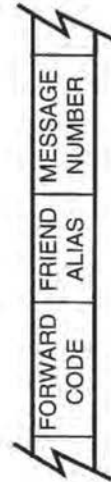
**FIG. 8** PMU→SC



**FIG. 9** SC→PMU

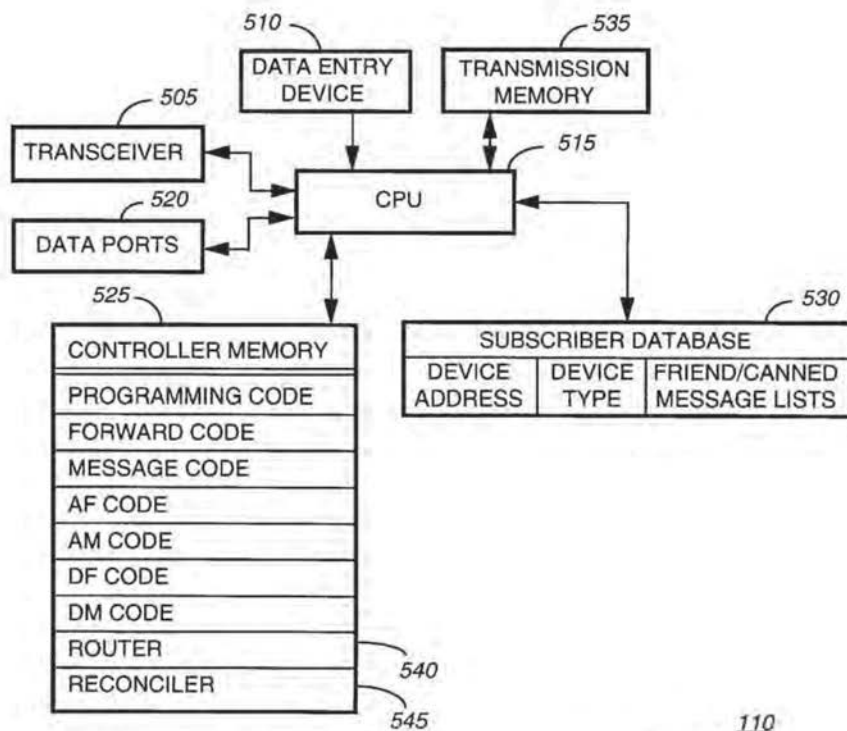


**FIG. 10** PMU→SC



**FIG. 11** PMU→SC





110  
**FIG. 12**

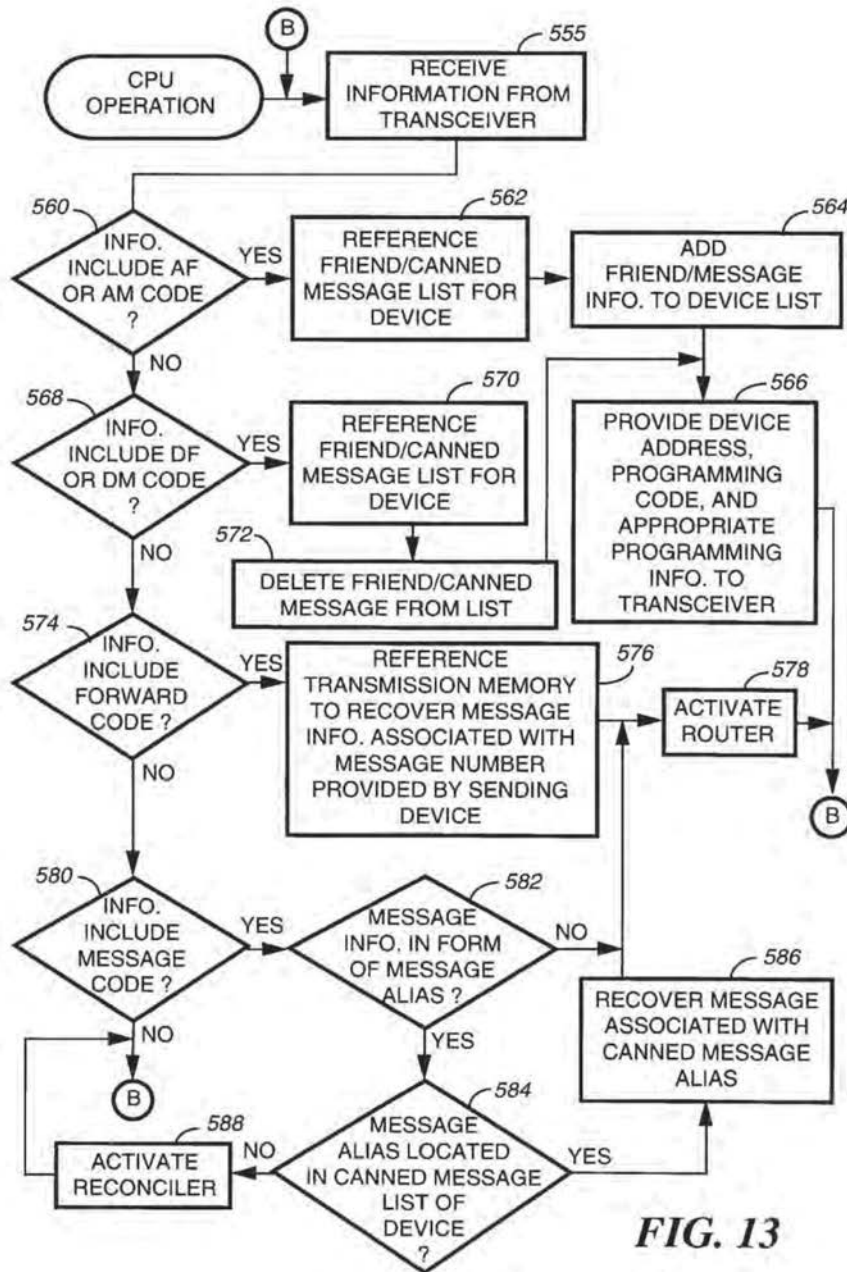


FIG. 13

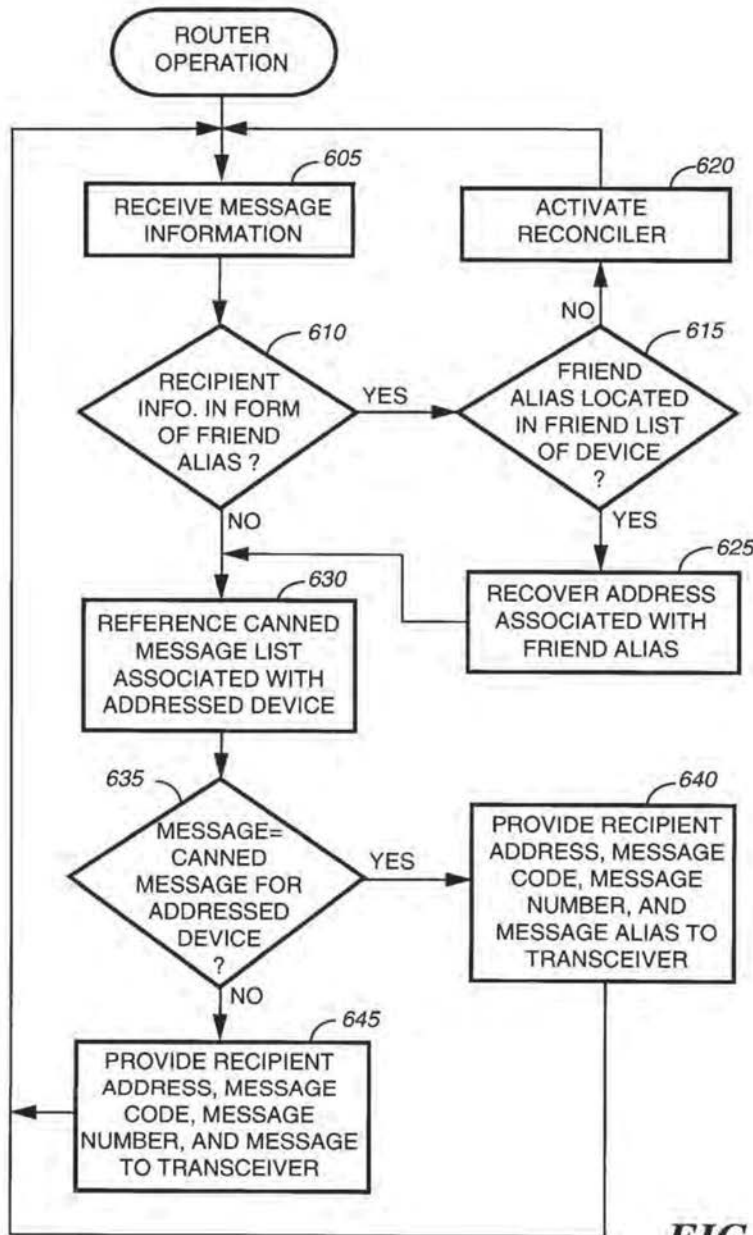


FIG. 14

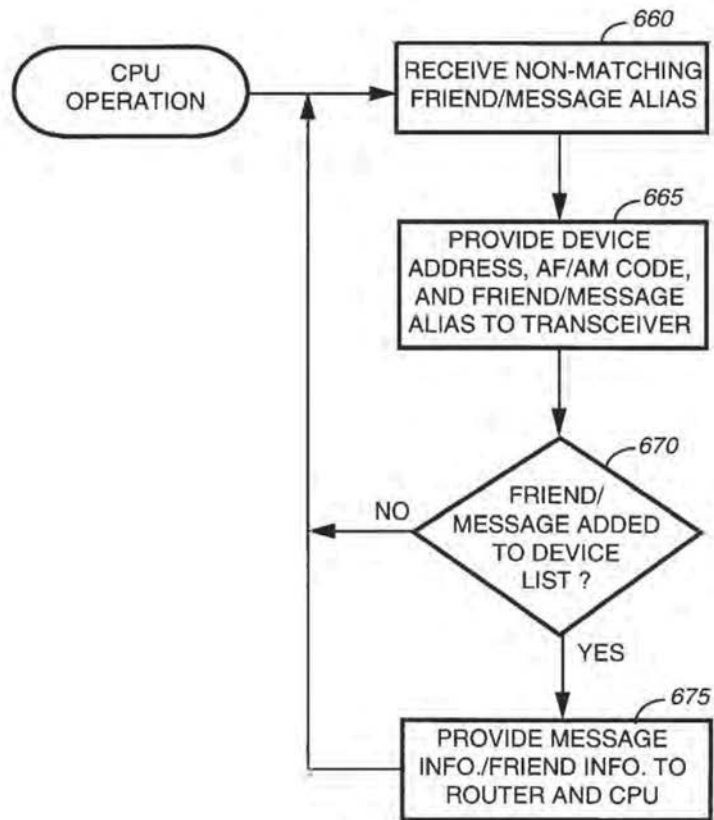


FIG. 15

**1**  
**METHOD AND APPARATUS FOR  
 EFFICIENTLY TRANSMITTING ADDRESSES  
 AND MESSAGES FROM PORTABLE  
 MESSAGING UNITS OVER A WIRELESS  
 COMMUNICATION CHANNEL.**

FIELD OF THE INVENTION

This invention relates in general to systems including portable messaging units, and more specifically to portable messaging units for sending and receiving messages over wireless communication channels.

BACKGROUND OF THE INVENTION

Wireless communication systems typically provide messages to subscriber units, such as portable messaging units. With the advent of two-way messaging, portable messaging units have also been able to transmit to other portable units and to fixed devices, such as computers. Messages in the communication system are generally delivered and/or received over a wireless communication channel, which usually has a limited bandwidth that permits only a limited amount of information to be transmitted over the channel within a specified time interval. Therefore, it is desirable to keep messages transmitted over the wireless channel as short as possible.

However, subscribers to the communication system often wish to send and receive relatively long messages. Also, addresses indicative of recipient devices are sometimes quite lengthy. For instance, electronic mail standards usually require extensive header information that is unsuitable for transmission over a wireless channel of limited bandwidth. As a result, two-way messaging can unduly crowd communication systems, resulting in inefficient channel use and message delays.

Thus, what is needed is a way to provide more efficient messaging in a wireless communication system including portable messaging units.

BRIEF DESCRIPTION OF THE DRAWINGS

FIG. 1 is an illustration of a communication system including portable messaging units (PMUs) and a system controller according to the present invention.

FIG. 2 is an electrical block diagram of a PMU included in the communication system of FIG. 1 according to the present invention.

FIG. 3 is a flowchart of an operation of a processor included in the PMU of FIG. 2 according to the present invention.

FIG. 4 is a flowchart of an operation of a receiver included in the PMU of FIG. 2 according to the present invention.

FIG. 5 is a flowchart depicting an operation of a sender included in the PMU of FIG. 2 according to the present invention.

FIGS. 6-11 are signal diagrams illustrating signals provided between the PMU of FIG. 2 and the system controller of FIG. 1 according to the present invention.

FIG. 12 is an electrical block diagram of the system controller included in the communication system of FIG. 1 according to the present invention.

FIG. 13 is a flowchart illustrating an operation of a central processing unit (CPU) included in the system controller of FIG. 12 according to the present invention.

FIG. 14 is a flowchart depicting an operation of a router included in the system controller of FIG. 12 according to the present invention.

**2**

FIG. 15 is a flowchart depicting an operation of a recon-ciler included in the system controller of FIG. 12 according to the present invention.

DESCRIPTION OF A PREFERRED  
 EMBODIMENT

FIG. 1 is an illustration of a communication system 100 for providing two-way communication between a system controller 110 and one or more portable messaging units (PMUs) 105, such as battery powered selective call receivers, over at least one wireless communication channel, e.g., at least one radio frequency communication channel. The system controller 110 can also be coupled to other types of devices, such as computers 115, by wireline communication links. Because radio frequency communication channels typically have limited bandwidths, only a limited amount of information can be transmitted over a channel within a specified time interval. Therefore, the communication system 100 according to the present invention employs relatively short aliases to communicate frequently transmitted information from the PMUs 105 to the system controller 110. Specifically, frequently used messages can be represented by message aliases, and addresses of recipients to whom messages are frequently sent can be represented by recipient aliases. Such recipients can be referred to as "friends".

Databases of the frequently transmitted information and the associated aliases are preferably stored at the PMUs 105 and at the system controller 110 so that each device can recognize an alias and conveniently interpret the more lengthy message or friend address associated therewith. In accordance with a preferred embodiment of the present invention, the databases of both the system controller 110 and the PMUs 105 are updated, when necessary, by the controller 110 to avoid situations in which information stored in a PMU database is not equivalent to that stored in the controller database.

FIG. 2 is an electrical block diagram of a PMU 105, which includes a transceiver 205 for sending and receiving information over a radio frequency communication channel and a processor 210 for controlling operations of the PMU 105. Controls 215 provide user-initiated signals to the processor 210, and a display 220 presents information to a user in response to activation by the processor 210. A message memory 225 is coupled to the processor 210 for storing received messages and message numbers associated with the received messages. Also, a database 230 is coupled to the processor 210 for storing the frequent recipient, i.e., friend, list and the frequent message list. Preferably, the lists in the database 230 are maintained in accordance with instructions by the user of the PMU 105 by over-the-air programming.

In accordance with the preferred embodiment of the present invention, each friend included in the friend list is associated with a recipient alias. More specifically, entries in the friend list include names of recipients, or friends, to whom messages are frequently sent and aliases of addresses associated with the friends. The addresses could also be included in the database 230, if desired. An entry in the friend list could, for instance, be as follows:

Friend	Alias	Address
Lou	00011	r_lou_b003@email.company.com@INTERNET

3

According to the present invention, a friend list entry could include more than one recipient or even a group of people. Such an entry could be as follows:

Friend(s)	Alias	Address(es)
Lou, Jim, and Ed	00011	t_lou_b003@email.company.com@INTERNET jim_0001@email.company.group.com edward_g004@company.grp.com@INTERNET

Similarly, each message included in the message list is associated with a message alias. These "canned messages" are also preferably associated with a message designation, which could be set by the user, so that the user can easily remember the message and select it for transmission by providing information to the processor 210 via the controls 215. An entry in the message list could, for example, include a number as a designator and be as follows:

Message Designation	Alias	Canned Message
7	001010	MEET ME IN THE CAFETERIA FOR COFFEE

When messages entries are instead designated by a key word or words, an entry could be as follows:

Message Designation	Alias	Canned Message
Coffee	001010	MEET ME IN THE CAFETERIA FOR COFFEE

As illustrated, the messages and the addresses to which the messages are transmitted by the PMU 105 can be relatively lengthy and unsuitable for frequent transmission over the radio communication channel. Therefore, in accordance with the present invention, the friend and message aliases are instead transmitted from the PMU 105 to the system controller 110 over the radio frequency communication channel to minimize the likelihood of channel crowding and resulting delays. Preferably, friend and message aliases comprise codes that include a predetermined number of bits, wherein the codes include a fewer number of characters than do the recipient addresses or the canned messages. By way of example, the friend aliases could comprise five-bit codes, thereby permitting storage of up to thirty-two friends. The message aliases could comprise six-bit codes, thereby permitting storage of up to sixty-four canned messages. It will be appreciated that different types of codes or different numbers of characters could alternatively be used for the aliases.

According to the present invention, the PMU 105 further includes a device memory 235 for storing device information, such as the address of the device. The device memory 235 also preferably stores a programming code for recognizing incoming programming information from the system controller 110 (FIG. 1), a forward code used for forwarding received messages to a friend, a message code used for sending and receiving messages, and a send code used for recognizing transmission commands received from the controls 215. Other codes for designating other transmitted and received signals include an "add friend" (AF) code, a "delete friend" (DF) code, an "add message" (AM) code, and a "delete message" code, as will be explained in greater detail below.

4

A sender 240 included in the PMU 105 prepares information for transmission from the PMU 105, and a receiver 245 processes received information. Preferably, the sender 240 and the receiver 245 comprise firmware stored in the device memory 235 and executed by the processor 210. Alternatively, the sender 240 and receiver 245 could be implemented using hardware capable of performing equivalent operations.

FIG. 3 is a flowchart of an operation of the processor 210 according to the present invention. When, at step 255, information is received from the transceiver 205, the receiver 245 is activated, at step 260. When, at steps 265, 270, a signal is received from the controls 215, and the signal includes the send code, the sender 240 is activated, at step 275. When, at steps 265, 270, another type of signal is received from the controls 215, other processing is performed, at step 280, by the processor 210.

Referring next to FIG. 4, a flowchart illustrates an operation of the receiver 245. When, at step 305, the receiver 245 receives information including a programming code, the programming information is stored in the appropriate location of the database 230, at step 310. For instance, when the programming information includes an "add" command and friend or message information, the information is added to the friend or message list as instructed by the system controller 110. It will be appreciated that friend information could also be modified via over-the-air programming from the controller 110, such as by including modified information with an add command or by using a unique "modify" command. When the programming information includes a "delete" command and information by which a friend or message entry can be identified, the friend or message entry is deleted from the appropriate list.

At step 315, the received information could include an AF, AM, DF, or DM code directing the PMU 105 to inquire of the user whether a friend or message should be deleted or whether an additional alias, e.g., an additional recipient alias, should be added. In this case, at step 320, information received with the code is displayed, at step 320, on the display 220. When, for instance, the system controller 110 has received a communication from the PMU 105 and does not recognize an included friend or message alias, the controller 110 can transmit an inquiry to the PMU 105 asking whether a new friend or new message is to be added to a list stored in the database 230. When the system controller 110 receives a delete message (DM) command or a delete friend (DF) command from a different PMU in the communication system 100 (FIG. 1), the controller 110 could inquire as to whether the user of the PMU 105 would also like to delete the message or friend. For instance, when a particular user requests that a friend be deleted, an inquiry could automatically be provided to the "deleted" friend asking whether the user should also be deleted from the friend's list. When the friend answers in the affirmative, the system controller 110 could delete the user from the friend list associated with the PMU of the deleted friend. Once the inquiry is displayed, at step 320, the receiver 245 awaits the reception, at step 325, of a user-initiated signal indicating a response. Thereafter, at step 330, the sender 240 is activated, at step 330, to transmit the response to the system controller 110.

When, at step 335, the information received by the receiver 245 includes a message code, indicating that the system controller 110 is routing a message to the PMU 105 over the wireless communication channel, a message number associated with the message and included in the signal is stored, at step 340, in the message memory 225. The

5

receiver 245 then compares, at step 345, the received message information with aliases stored in the message list. When the received message information is equivalent to a canned message alias, the message associated with the matching alias is retrieved from the list and stored, at step 355, in the message memory 225. Otherwise, the message information itself is stored in the message memory 225, at step 350. Thereafter, the message can be presented to the user in a conventional manner.

FIG. 5 is a flowchart illustrating an operation of the sender 240 according to the present invention. At step 405, a signal is received from the controls 215. When, at step 410, the signal includes a DF or DM code, indicating that the user wants to delete a friend or message entry identified by the received user-initiated signal, the database 230 is referenced, at step 415, to recover the selected friend or message information and the alias associated therewith. The sender 240 then provides, at step 420, the appropriate DF or DM code to the transceiver 205 along with enough information to identify the entry that is to be deleted. For example, the alias and the entry information, such as friend name, friend address, message designation, and/or actual message, can be provided to the transceiver 205 with the DF or DM code to assist the controller 110 in locating the correct entry. As mentioned above, the controller 110, in response to receiving the code and related information, transmits programming information to the PMU 105 for updating the database 230.

When, at step 425, the user-initiated signal includes an AM or AF code, indicating that the user desires to add an additional message or friend to the database 230, the sender 240 further determines, at step 430, whether the signal references a previously received message. When the user-initiated signal does not reference a previously received message, the AF or AM code and the friend or message information which is to be entered into the database 230 is provided, at step 440, to the transceiver 205. When the signal references a previously received message, indicating that the message or the message originator is to be added to the database 230, sufficient identifying information, e.g., message number, friend information, actual message, or address information, is recovered from the message memory 225, at step 435, and provided to the transceiver 205 along with the AF or AM code, at step 440.

At step 445, reception of a signal including a forward code indicates that a previously received message is to be forwarded to another recipient. When, at step 450, the intended recipient is a friend, i.e., when the intended recipient is included in the friend list, the forward code, the friend alias, and the message number of the message to be forwarded are provided to the transceiver 205, at step 455. When the intended recipient is not included in the friend list of the PMU 105, the forward code, the message number, and an address entered by the user are provided, at step 460, to the transceiver 205.

When, at step 465, the signal includes a message code, indicating that a message is to be transmitted to another device, the sender 240 references, at step 470, the database 230 to determine whether the designated recipient is a friend and whether the entered message is a canned message. Thereafter, at step 475, the message code, the friend alias or recipient address, and the message information or message alias are provided to the transceiver 205.

Although the PMU 105 is described as transmitting one friend alias or one message alias to the system controller 110, it will be appreciated that more than one alias can be transmitted when the user so indicates. When, for instance,

6

a message is to be transmitted to three friends that are not grouped under a single alias, aliases for each of the friends can be transmitted to the system controller 110.

As described above, the system controller 110 modifies the database 230 of the PMU 105 so that the lists stored in the controller 110 and the lists stored in the PMU 105 remain equivalent. However, one of ordinary skill will recognize that other methods for ensuring agreement between the PMU lists and the controller lists can alternatively be employed. By way of example, the user of the PMU 105 could add to, delete from, or modify the database 230 via the controls 215, in response to which AF, AM, DF, and DM codes and information could be automatically provided to the controller 110 to update the lists stored thereby.

FIGS. 6-11 are signal diagrams illustrating signals communicated between the system controller 110 and the PMU 105 in accordance with the present invention. FIG. 6 depicts an example of information that could be sent by the PMU 105 to the system controller (SC) 110 to add a friend to the database 230 (FIG. 2). The information could include the AF code followed by the friend designation, e.g., name, and the friend address. When an originator of a previously received message is to be added to the friend list, a friend name and a message number associated with the previous message could simply be appended to the AF code, in which case the controller 110 could look up the previous message to assign a friend alias to the address of the message originator. FIG. 7 shows an example of a responsive signal provided by the controller 110 to the PMU 105. The responsive signal preferably comprises the PMU address, the programming code, and programming information, which includes at least an add command, an assigned friend alias, and the friend name for storage in the database 230 of the PMU 105. Rather than providing separate programming codes and add commands, it will be appreciated that a unique "add" programming code could be transmitted.

In FIG. 8, the PMU 105 requests the deletion of a friend from its database 230 by sending the DF code followed by the entry identification information, which could include the friend alias and/or friend name. In response, as shown in FIG. 9, the controller 110 transmits the PMU address, the programming code, the delete command, and information indicative of the friend list entry, such as the alias of the friend. The processor 210 (FIG. 2) then deletes the friend from the database 230.

FIGS. 10 and 11 show examples of message transmissions from the PMU 105. In FIG. 10, the PMU 105 transmits a frequently transmitted message to a friend by sending the message code, the friend alias, and the message alias. The controller 110 receives the signal and decodes the friend alias and the message alias. The controller 110 then sends the message indicated by the message alias to an address associated with the friend alias. In FIG. 11, the PMU 105 forwards a previously received message to a friend by transmitting the forward code, the friend alias, and the number of the previous message. The controller 110, in response to receiving the forward signal, decodes the friend alias and looks up the message associated with the message number. The message is then transmitted to the address associated with the friend alias.

Although not shown in FIGS. 6-11, it will be appreciated that some method of identifying the transmitting PMU 105 can be included in the signal if necessary. For instance, the PMU address could be sent to identify the PMU 105. Alternatively, prior art methods such as transmitting on a given frequency or at a given time could be used. It will be further appreciated that canned messages can be added and

deleted by the PMU 105 in the manner described for adding and deleting friends.

The signals transmitted by the PMU 105 to the system controller 110 over the wireless communication channel can be relatively short because the aliases are often significantly shorter in length than are the related addresses and messages. As a result, the likelihood of crowding the channel is minimized, rendering message delivery delays less likely.

Use of the aliases by the PMU 105 is also convenient for the user because the user does not have to memorize lengthy addresses of friends or enter large amounts of information every time a message is to be sent. For instance, the user only has to memorize a friend's name, e.g., Lou, rather than the friend's address, which could comprise a large number of characters that are not easily remembered. Additionally, the user only has to enter the word "Lou" to indicate the recipient. This eliminates situations in which the user has to continually reference a personal address book to recover a lengthy address, thereby saving time. Also, the likelihood of user error in typing lengthy addresses is minimized by using the aliases, thereby increasing the probability of error-free message delivery to the intended recipient.

FIG. 12 is an electrical block diagram of the system controller 110, which includes a transceiver 505 for sending and receiving information, a central processing unit (CPU) 515 for processing the information, and a transmission memory 535 for storing messages that are transmitted within the communication system 100 (FIG. 1). Data ports 520 are included in the controller 110 for transmitting messages to and receiving messages from wired devices, such as computers 115 (FIG. 1). The controller 110 can also be coupled by the data ports 520 to a telephone network, such as the public switched telephone network (PSTN), for receiving message information from message originators via telephones and modems. A subscriber database 530 is coupled to the CPU 515 for storing subscriber information, such as addresses of devices that subscribe for service within the system 100 and friend and message lists associated with subscribing PMUs. A data entry device 510 can be used to update the subscriber database 530.

The controller 110 also includes a controller memory 525 for storing information used in operating the controller 110. The controller memory 525 preferably stores the programming code, the forward code, the message code, and AF, AM, DF, and DM codes. A router 540 included in the controller 110 transmits messages within the communication system 100, and a reconciler 545 updates friend and message lists stored by the controller 110 and the PMUs within the communication system 100. Preferably, the router 540 and the reconciler 545 are firmware elements stored in the memory 525 and executed by the CPU 515 during operation of the controller 110. Alternatively, the router 540 and the reconciler 545 can be implemented as hardware capable of performing equivalent operations.

FIG. 13 is a flowchart of an operation performed by the CPU 515, which, at step 555, receives information from the transceiver 505. When, at step 560, the information includes an AF code or an AM code, indicating that the user of a PMU 105 wants to add a friend or message alias, the lists associated with that PMU 105 are referenced, at step 562, in the subscriber database 530. The friend or message information appended to the AM or AF code is then assigned an additional message alias or an additional friend alias and added, at step 564, to the appropriate list associated with the PMU 105.

When, at step 568, the information includes a DM or DF code, indicating that the user of the PMU 105 wishes to

delete a friend or canned message from its memory, the lists associated with the PMU 105 are referenced, at step 570, and the entry associated with the incoming DM or DF code is deleted from the PMU's list in the subscriber database 530, at step 572. Once the CPU 515 has deleted information from or added information to the PMU's friend or canned message list maintained locally by the controller 110, at steps 564, 572, the CPU 515 proceeds to modify the database 230 (FIG. 2) stored by the PMU 105 accordingly. This is done by providing, at step 566, the PMU address, programming code, and appropriate programming information to the transceiver 505 for transmission to the PMU 105.

When, at step 574, the information received by the CPU 515 includes a forward code, indicating that the user of the PMU 105 is forwarding a previously received message, the transmission memory 535 is referenced, at step 576, to recover the message associated with the message number appended to the forward code. Thereafter, the router 540 is activated, at step 578.

When, at step 580, the information received by the CPU 515 includes a message code, indicating that the user of the PMU 105 is sending a message to another device, the CPU 515 determines, at step 582, whether the message information included in the incoming signal is in the form of a message alias. For example, the CPU 515 could actively search for a predetermined number of bits, e.g., five bits, in a predetermined location of the signal or for predetermined markers that indicate the start or end of a message alias. When no message alias is included, the router 540 is activated, at step 578. When a message alias is included in the signal from the PMU 105, the CPU 515 references, at step 584, the subscriber database 530 to determine whether the received message alias is included in the canned message list associated with the PMU 105. When it is, the message associated with the canned message alias is recovered, at step 586, and the router 540 is activated, at step 578. When the message alias is not located in the PMU's list, the reconciler 545 (FIG. 12) is activated, at step 588.

Referring next to FIG. 14, a flowchart depicts an operation of the router 540, which is activated by reception, at step 605, of message information comprising a message and recipient information. When, at step 610, the recipient information includes a friend alias, the router 540 determines, at step 615, whether the friend alias is included in the PMU's friend list stored in the subscriber database 530. When the friend alias is not included in the friend list, the reconciler 545 is activated, at step 620. When the friend alias is located, the address associated with the alias is recovered, at step 625, from the friend list.

Thereafter, at step 630, the canned message list for the recipient device is referenced. When, at step 635, the message to be sent to the device comprises a canned message stored in the device's list, the message alias representative of the message is recovered. The recipient address, the message code, the message number, and the message alias are then provided, at step 640, to the transceiver 505 for transmission to the recipient device, which can, for instance, comprise another PMU. When the message to be sent to the device is not a canned message, the message itself, rather than an alias, is provided to the transceiver 505 for transmission, at step 645.

FIG. 15 is a flowchart of an operation of the reconciler 545, which, at step 660, receives a non-matching friend or message alias, in response to which the address of the PMU 105 providing the non-matching alias, the AM or AF code, and the non-matching alias is provided to the transceiver 505 for transmission to the PMU 105. As mentioned above,



reception by the PMU 105 triggers an inquiry at the PMU 105 to ask the user whether friend or message information is to be added for the alias that was previously transmitted by the PMU 105. The reconciler 545 then awaits subsequent reception of an AF or AM code to indicate that a friend or message is to be added to the PMU's list responsive to the inquiry. When an AF or AM code is received within a predetermined amount of time of the inquiry, indicating, at step 670, that a friend or message is to be added to the list, the message information or friend information is provided, at step 675, to the router 540 and the CPU 515. The router 540 and the CPU 515 can then process the alias that was previously not recognized, at step 584 (FIG. 13) and step 615 (FIG. 14).

In summary, the communication system described above includes a portable messaging unit for transmitting information to and receiving information from a system controller over a wireless communication channel. Because the wireless communication channel could become overcrowded by frequent transmissions of lengthy messages and addresses, the portable unit maintains lists of frequently used addresses and messages. Each entry in the lists is aliased with a code that is usually shorter than the referenced message or address. For instance, a very long message that is often transmitted could be aliased with a message alias comprising six bits, while a fairly lengthy address to which messages are often transmitted could be aliased with a recipient alias comprising five bits. Thereafter, when a message included in the message list is to be transmitted, the shorter message alias, rather than the message itself, is transmitted. When transmissions are to be made to a recipient included in the recipient list, the shorter recipient alias, rather than the address of the recipient, is transmitted. As a result, the communication channel is efficiently used to transmit relatively short transmissions, which prevents system capacity from being exceeded and which prevents message delays due to overcrowding of the channel.

The system controller also maintains the message and recipient lists associated with each portable messaging unit in the communication system. Therefore, the system controller recognizes recipient and message aliases transmitted by a portable unit. The controller, in response to reception of a recipient or message alias, references the sending unit's lists that are locally stored to recover the actual message or address that has been aliased. The message is then provided to the recipient device having the address. Alternatively, when the recipient device also is associated with message and recipient lists stored both by the device and the system controller, the system controller references the lists to determine whether the message to be sent is included in the message list of the recipient device. When so, an alias, rather than the more lengthy message, can be advantageously transmitted to the recipient device.

According to the present invention, the system controller maintains the recipient and message lists stored by portable units by programming the units over the air. Therefore, the probability of disagreement between the lists of the portable units and the lists maintained by the controller is minimized, which reduces the likelihood of missed or delayed messages resulting from unrecognized aliases. The user of a portable unit can conveniently add a recipient or message to his recipient or message lists by transmitting an "add" request, in response to which the controller assigns an additional alias and modifies the portable unit's list by over-the-air programming. When the user wishes to delete a frequent recipient or canned message, a "delete" request is transmitted, in response to which the controller deletes the

selected entry from its locally maintained list and from the list stored in the portable unit. In this manner, the lists of the controller and the portable units are equivalent at any time, and situations do not result in which the user modifies the list and the portable unit, then forgets to modify the list at the controller.

Another advantage of the present invention is that the user is provided with a convenient way of entering message and address information. Specifically, the user does not have to remember relatively long addresses for entry into the portable messaging unit. Instead, the user only has to remember and enter a relatively short recipient alias or message designation rather than a lengthy address or message. Therefore, the likelihood of incorrectly entered addresses is minimized, which increases the probability of proper message delivery.

It will be appreciated by now that there has been provided a more efficient messaging system for transmitting message to and receiving messages from portable messaging units.

What is claimed is:

1. A communication system for providing two-way communication, the communication system comprising:

a portable messaging unit for sending a signal comprising a recipient alias over a wireless communication channel, the portable messaging unit comprises a list including names of recipients and recipient aliases associated therewith and further comprises a sender for requesting that an additional recipient be added to the list; and

a controller for receiving the signal including the recipient alias and for transmitting a message to an address designated by the recipient alias, wherein the address is longer than the recipient alias, the controller includes a database in which the list associated with the portable messaging unit is also stored and further comprises a processing unit for assigning an additional recipient alias to the additional recipient and for adding the additional recipient alias and the additional recipient associated therewith to the list maintained by the portable messaging unit by transmitting programming information thereto.

2. A communication system for providing two-way communication, the communication system comprising:

a portable messaging unit for sending a signal comprising a recipient alias over a wireless communication channel, the portable messaging unit comprises a list including names of recipients and recipient aliases associated therewith and further comprises a sender for requesting that one of the recipients be deleted from the list; and

a controller for receiving the signal including the recipient alias and for transmitting a message to an address designated by the recipient alias, wherein the address is longer than the recipient alias, the controller includes a database in which the list associated with the portable messaging unit is also stored and further comprises a processing unit for deleting the one of the recipients from the list maintained by the portable messaging unit by transmitting programming information thereto.

3. A communication system for providing two-way communication, the communication system comprising:

a portable messaging unit for sending a signal comprising a recipient alias over a wireless communication channel, the portable messaging unit comprises a list including names of recipients and recipient aliases associated therewith; and

## 11

- a controller for receiving the signal including the recipient alias and for transmitting a message to an address designated by the recipient alias, wherein the address is longer than the recipient alias, the controller includes a database in which the list associated with the portable messaging unit is also stored; 5
- the controller further comprises:
- a reconciler for determining that the recipient alias is not included in the list associated with the portable messaging unit; and
  - a router coupled to the reconciler for inquiring of the portable messaging unit whether a recipient associated with the recipient alias is to be added to the list. 10
4. A communication system for providing two-way communication, the communication system comprising:
- a portable messaging unit, comprises a list including messages and message aliases associated therewith, for sending a signal comprising a recipient alias and a message alias, rather than the message itself, and wherein the message is longer than the message alias, over a wireless communication channel, the portable messaging unit further comprises a sender for requesting that an additional message be added to the list maintained by both the portable messaging unit and the controller; and
  - a controller, includes a database in which the list associated with the portable messaging unit is also stored, for receiving the signal including the recipient alias and for transmitting a message to an address designated by the recipient alias, wherein the address is longer than the recipient alias, the controller further comprises a processing unit for assigning an additional message alias to the additional message and for adding the additional message alias and the additional message associated therewith to the list maintained by the portable messaging unit by transmitting programming information thereto. 15
5. A communication system for providing two-way communication, the communication system comprising:
- a portable messaging unit, comprises a list including messages and message aliases associated therewith, for sending a signal comprising a recipient alias and a message alias, rather than the message itself, and wherein the message is longer than the message alias, over a wireless communication channel, the portable messaging unit further comprises a sender for requesting that one of the messages be deleted from the list maintained by both the portable messaging unit and the controller; and
  - a controller, includes a database in which the list associated with the portable messaging unit is also stored, for receiving the signal including the recipient alias and for transmitting a message to an address designated by the recipient alias, wherein the address is longer than the recipient alias, the controller further comprises a processing unit for deleting the one of the messages from the list maintained by the portable messaging unit by transmitting programming information thereto. 20
6. A communication system for providing two-way communication, the communication system comprising:
- a portable messaging unit, comprises a list including messages and message aliases associated therewith, for sending a signal comprising a recipient alias and a message alias, rather than the message itself, and wherein the message is longer than the message alias, over a wireless communication channel; and
  - a controller, includes a database in which the list associated with the portable messaging unit is also stored, for 25

## 12

- receiving the signal including the recipient alias and for transmitting a message to an address designated by the recipient alias, wherein the address is longer than the recipient alias;
- the controller further comprises:
- a reconciler for determining that the message alias is not included in the list associated with the portable messaging unit; and
  - a router coupled to the reconciler for inquiring of the portable messaging unit whether the message associated with the message alias is to be added to the list. 5
7. A method for providing two-way communication in a communication system comprising a portable messaging unit and a controller, the method comprising the steps of:
- storing, in both the portable messaging unit and the controller, a recipient list including names of recipients and recipient aliases associated therewith and a message list including messages and message aliases associated therewith
  - the portable messaging unit sending a signal comprising a recipient alias over a wireless communication channel;
  - the controller receiving the signal including the recipient alias and determining that an alias transmitted by the portable messaging unit is not included in the recipient list or the message list and inquiring of the portable messaging unit whether information associated with the alias is to be added to the recipient list or the message list; and
  - the controller transmitting a message to an address designated by the recipient alias, wherein the address is longer than the recipient alias. 10
8. A method for providing two-way communication in a communication system comprising a portable messaging unit and a controller, the method comprising the steps of:
- storing, in both the portable messaging unit and the controller, a recipient list including names of recipients and recipient aliases associated therewith and a message list including messages and message aliases associated therewith
  - the portable messaging unit sending a signal comprising a recipient alias over a wireless communication channel and requesting that information be added to one of the recipient list and the message list maintained by both the portable messaging unit and the controller;
  - the controller receiving the signal including the recipient alias and assigning an additional alias to the information responsive to the requesting step and
  - the controller transmitting a message to an address designated by the recipient alias, wherein the address is longer than the recipient alias and transmitting programming information to the portable messaging unit to add the additional alias and the information associated therewith to the one of the recipient list and the message list maintained by the portable message unit. 15
9. A method for providing two-way communication in a communication system comprising a portable messaging unit and a controller, the method comprising the steps of:
- storing, in both the portable messaging unit and the controller, a recipient list including names of recipients and recipient aliases associated therewith and a message list including messages and message aliases associated therewith 20

**13**

the portable messaging unit sending a signal comprising a recipient alias over a wireless communication channel and requesting that information be deleted from one of the recipient list and the message list maintained by both the portable messaging unit and the controller;  
the controller receiving the signal including the recipient alias; and

**14**

the controller transmitting a message to an address designated by the recipient alias, wherein the address is longer than the recipient alias and transmitting programming information to the portable messaging unit to delete the information from the one of the recipient list and the message list maintained by the portable messaging unit.

\* \* \* \* \*



US005970122A

# United States Patent [19]

LaPorta et al.

[11] Patent Number: **5,970,122**

[45] Date of Patent: **\*Oct. 19, 1999**

[54] **TWO-WAY WIRELESS MESSAGING SYSTEM HAVING USER AGENT**

[75] Inventors: **Thomas F. LaPorta**, Thornwood, N.Y.; **Krishan Kumar Subnani**, Westfield, Thomas Yat Chung Woo, Red Bank, both of N.J.

[73] Assignee: **Lucent Technologies Inc.**, Murray Hill, N.J.

[\*] Notice: This patent issued on a continued prosecution application filed under 37 CFR 1.53(d), and is subject to the twenty year patent term provisions of 35 U.S.C. 154(a)(2).

[21] Appl. No.: **08/686,080**

[22] Filed: **Jul. 24, 1996**

[51] Int. Cl.<sup>7</sup> ..... **H04M 1/64; H04M 1/60; H04M 3/42; H04Q 7/00**

[52] U.S. Cl. .... **379/67.1; 379/76; 379/88.08; 379/88.22; 379/170; 379/173; 379/185; 379/201; 379/217; 455/31.1; 455/31.2; 455/31.3**

[58] Field of Search ..... **379/67, 88, 89, 379/67.1, 76, 88.04, 88.08, 88.22, 93.29, 93.34, 170, 173, 185, 201, 217; 455/31.1, 31.2, 31.3; 382/50, 251**

### [56] References Cited

#### U.S. PATENT DOCUMENTS

4,757,525 7/1988 Matthews et al. .... 379/89

5,159,592	10/1992	Perkins	370/85.7
5,283,818	2/1994	Klausner et al.	379/67
5,327,486	7/1994	Wolf et al.	379/96
5,363,425	11/1994	Mufli et al.	379/38
5,400,393	3/1995	Knuth et al.	379/88
5,483,577	1/1996	Cnlick	379/67
5,493,692	2/1996	Theimer et al.	455/26.1
5,533,019	7/1996	Jayapalan	370/60.1
5,608,786	3/1997	Gordon	379/100
5,680,437	10/1997	Segal	379/10
5,742,905	4/1998	Pepe et al.	455/461
5,752,191	5/1998	Fuller et al.	455/445
5,845,213	12/1998	Sumner et al.	455/488

Primary Examiner—Fan S. Tsang  
Assistant Examiner—Allan Hoosain

### [57] ABSTRACT

A two-way wireless messaging system includes a messaging network having at least one user agent corresponding to a subscriber of a two-way wireless messaging service. The subscriber receives messages from the messaging network along a first communication channel. The user agent includes a plurality of messages stored therein wherein a predetermined message is stored in the user agent and forwarded to a desired destination in response to an originating message code that is received from a two-way messaging device of the subscriber along a second communication return channel. The originating message code can be expanded by the user agent. The messages stored by the user agent can be modified so that different messages can be forwarded to the predetermined destination. The user agent also maintains location information of the two-way messaging device of the subscriber.

**40 Claims, 8 Drawing Sheets**

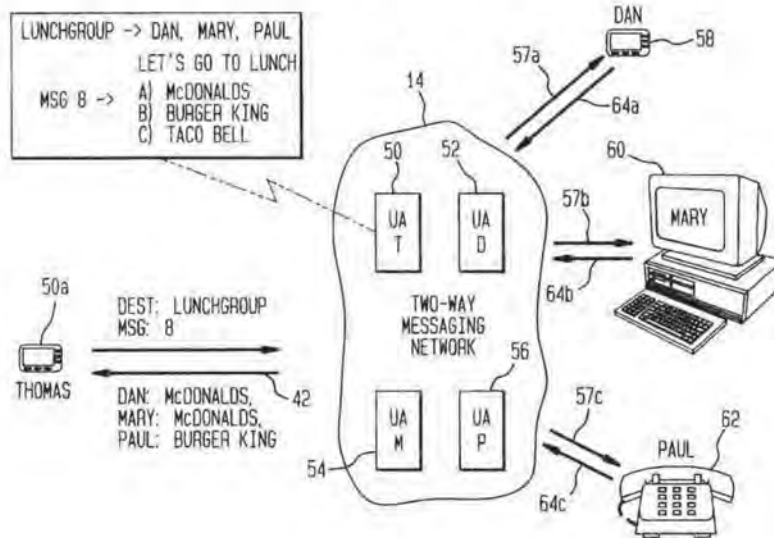


FIG. 1

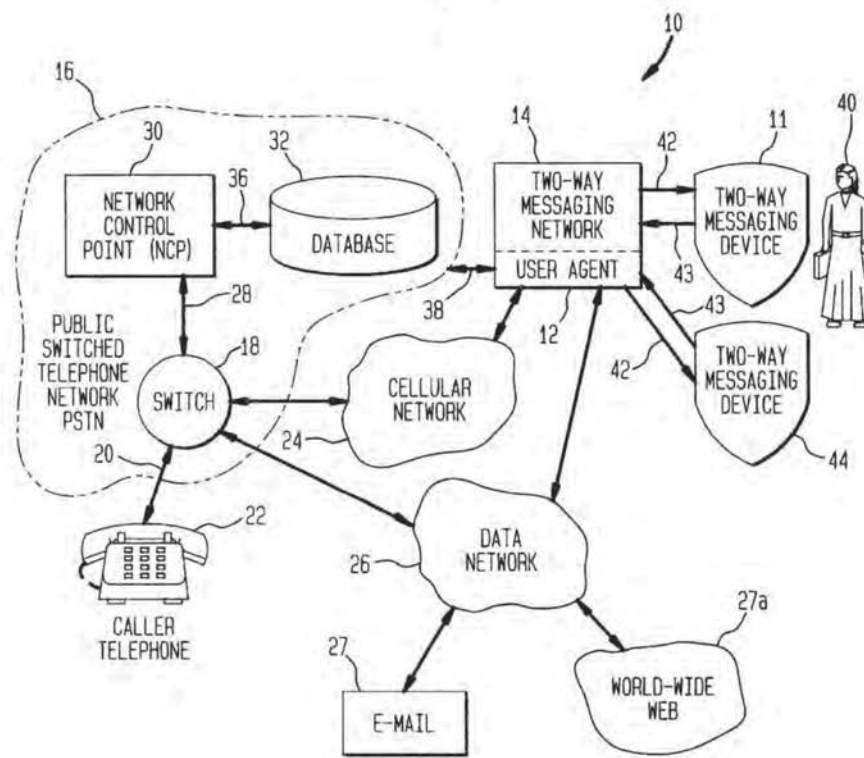


FIG. 2

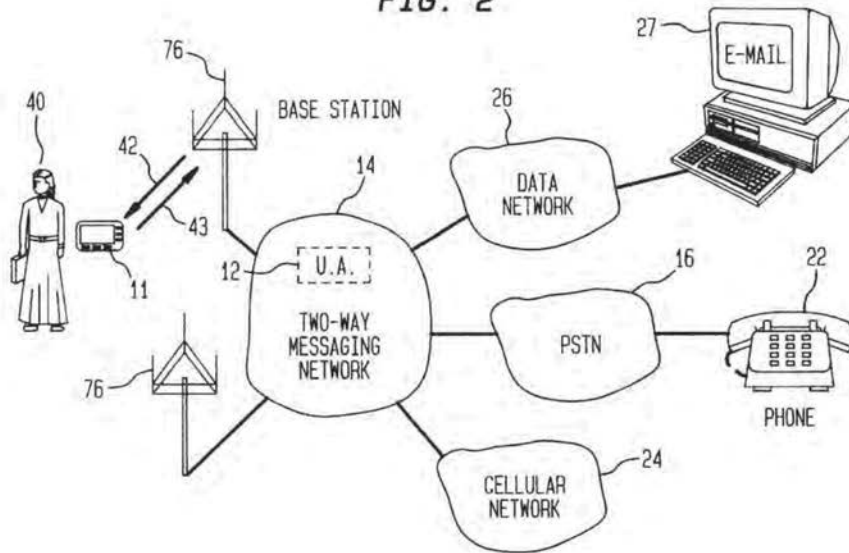


FIG. 3

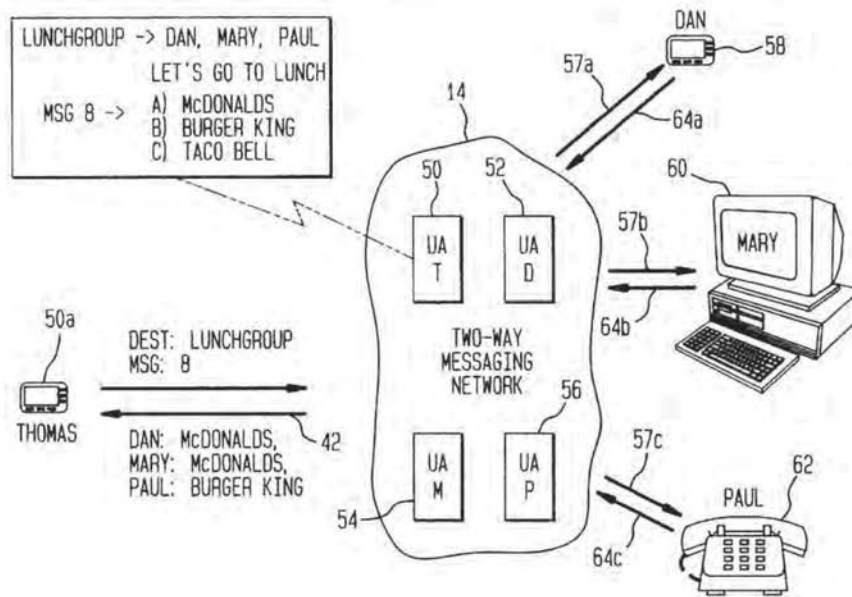


FIG. 4

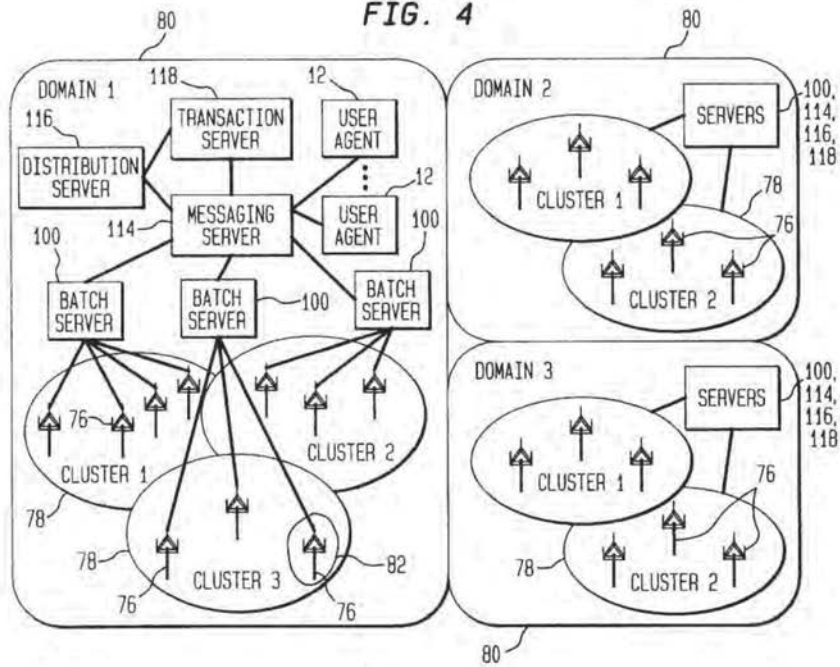


FIG. 5

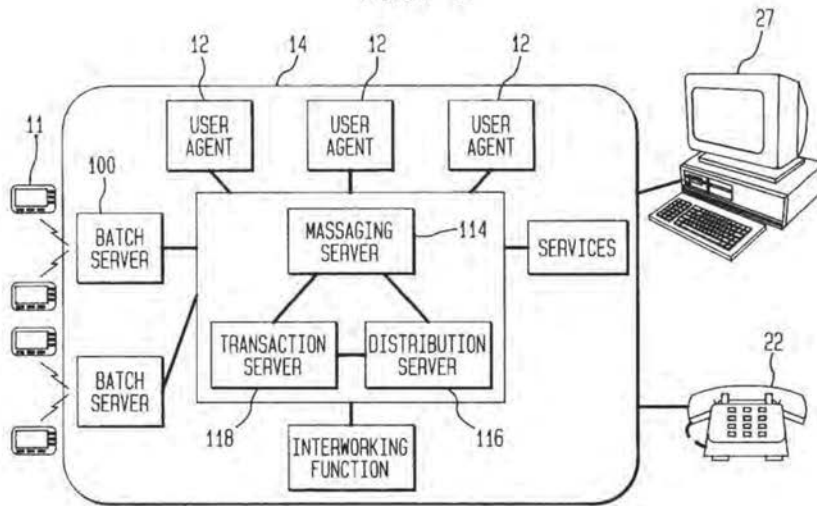


FIG. 6

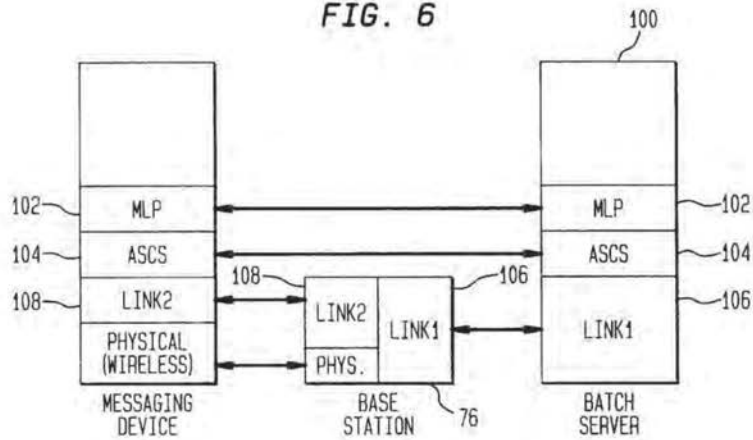
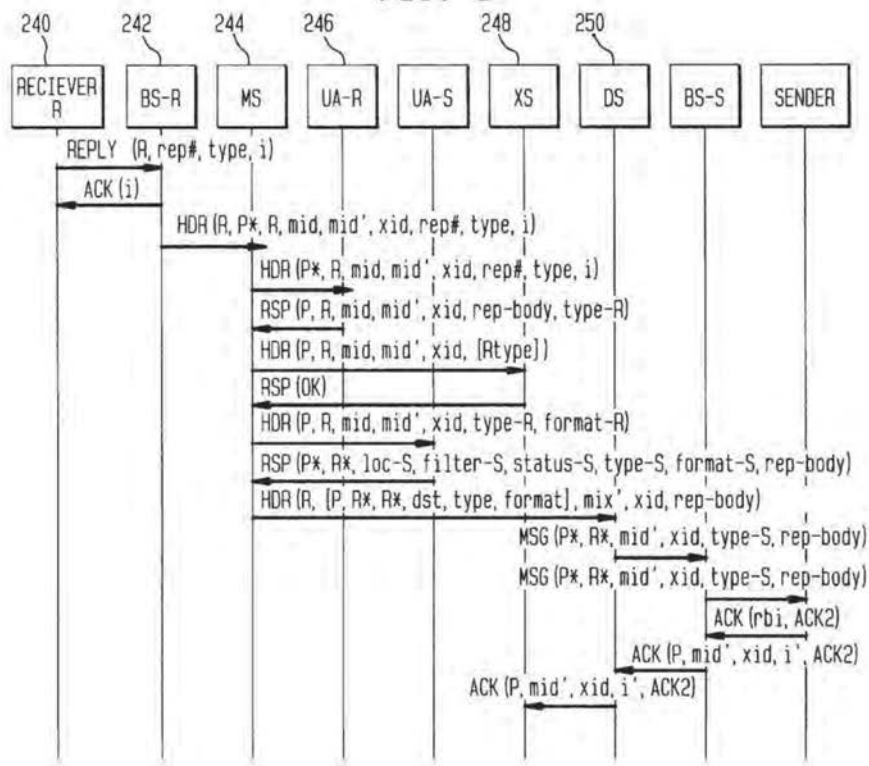


FIG. 8





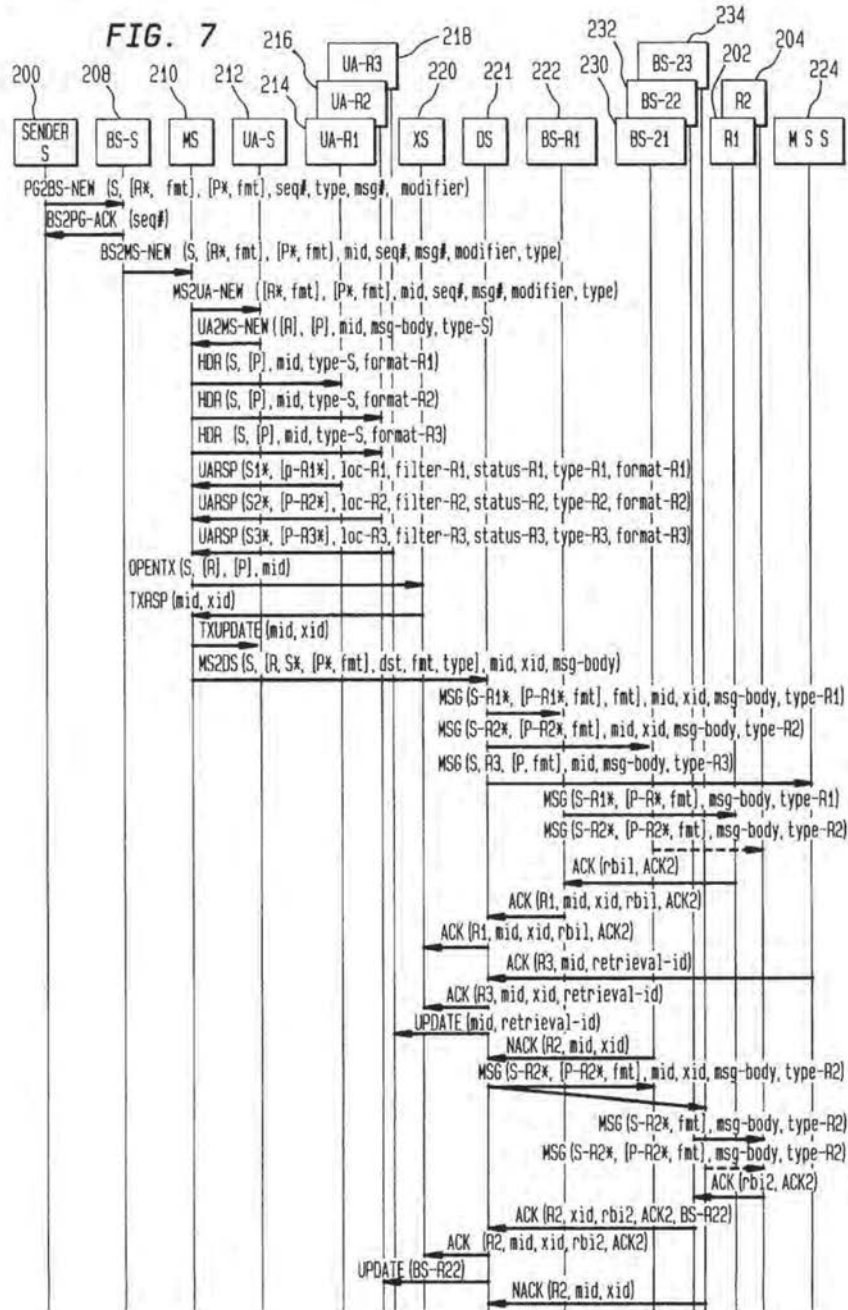


FIG. 9

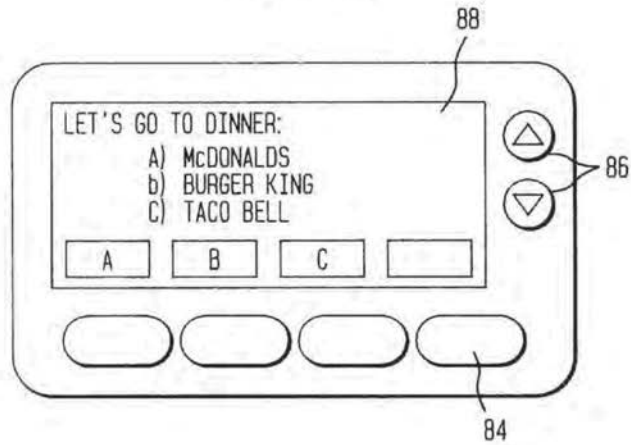


FIG. 10

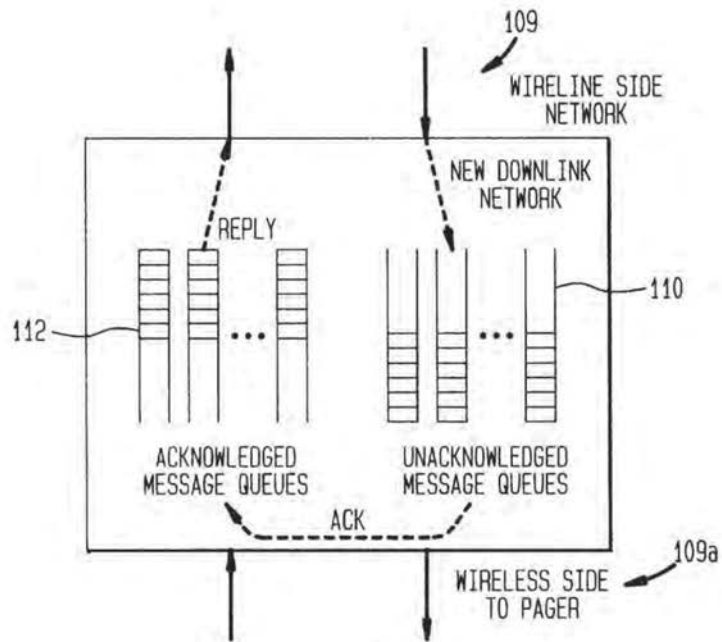


FIG. 11

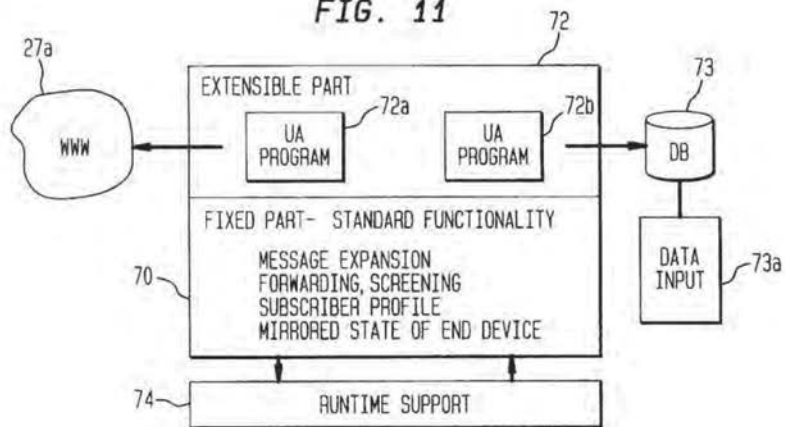


FIG. 12

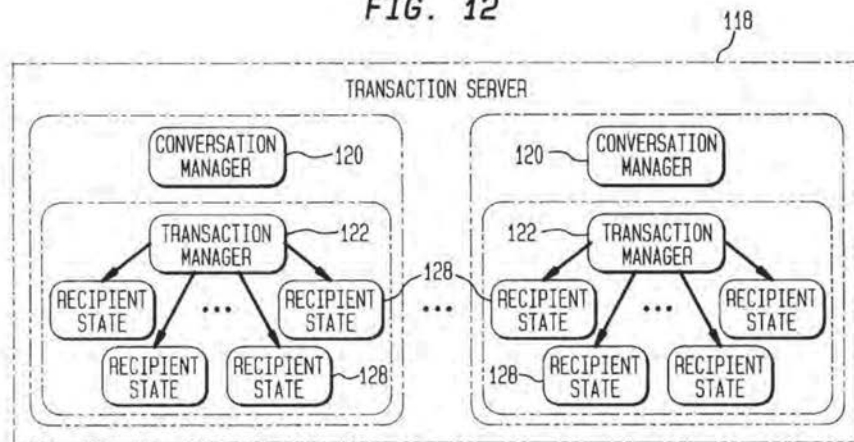


FIG. 12A

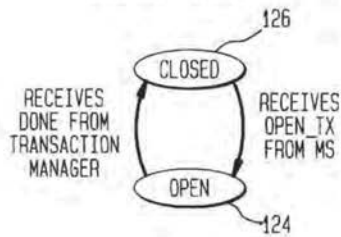
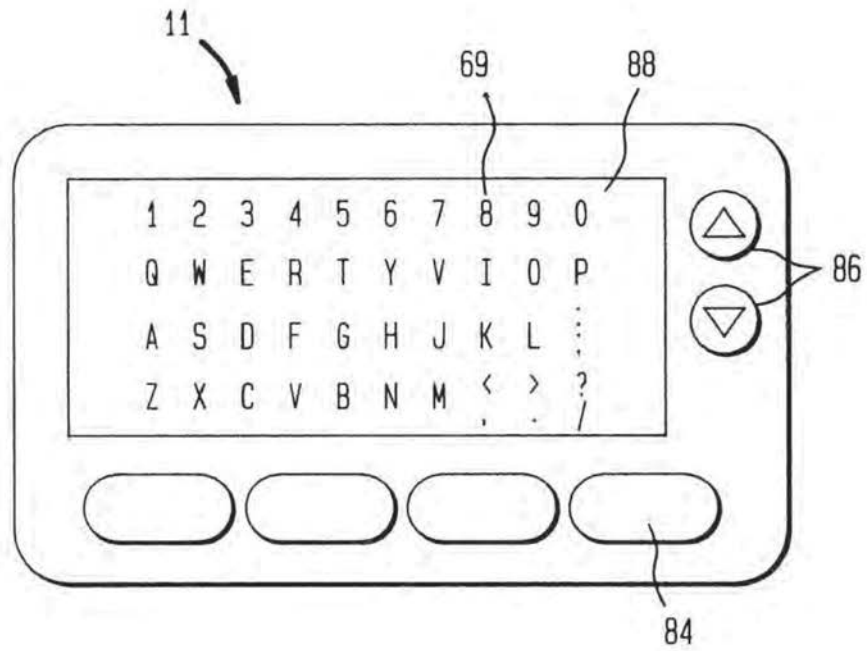


FIG. 12B



FIG. 13



1

## TWO-WAY WIRELESS MESSAGING SYSTEM HAVING USER AGENT

This application is related to commonly assigned, copending application entitled Two-Way Wireless Messaging System, filed on the same date as the present application by the same inventors.

### FIELD OF THE INVENTION

This invention relates to a two-way wireless messaging system and method using a messaging network having at least one subscriber user agent that stores messages that are forwarded to predetermined destinations.

### BACKGROUND OF THE INVENTION

Wireless messaging, such as wireless paging, is a popular consumer wireless service and will grow because of the availability of new narrowband Personal Communication Services (PCS) frequencies. Wireless communication and messaging provides the foundation for many different types of services. One popular service is one-way paging, which is now very successful. Its popularity has been contributed by numerous factors, including:

- (1) the small form factor of the pager device, making it portable;
- (2) the low cost of the paging service;
- (3) easy maintenance of the pager device; and
- (4) ease of use for both message senders and receivers.

One-way paging, however, has no reply capability. A subscriber to a one-way paging service must rely on an alternate method to respond to any messages that are received. For example, after receiving a page from the one-way paging service, a subscriber often has to find a telephone and make a call to respond to the message.

Recently, some ideas have been proposed to design a "two-way paging system" while preserving the benefits of one-way paging, i.e., the small paging device, low cost service, easy maintenance and ease of use. These two-way paging systems include return channels, but they are used only for fixed and limited replies.

In commonly assigned, copending patent application entitled Two-Way Wireless System, the disadvantages of the prior art wireless messaging systems are overcome through the use of a messaging network and two-way wireless messaging device which originates, receives and replies to messages having dynamic message components to and from the messaging network.

### SUMMARY OF THE INVENTION

The present invention allows even greater control over message delivery and expansion by the use of proxy agents in the message network.

Limitations of existing wireless paging systems are resolved and technical advances are achieved in the present invention by a method and system for transmitting messages on a wireless messaging network with a plurality of user agents and other intelligent servers such as transaction servers, distribution servers and batch servers. The benefits of the present invention are set forth below.

In accordance with one aspect of the present invention, a wireless messaging device can originate new messages or reply to previously received messages along a first communication channel (uplink), and receive messages along a second communication channel (downlink). Each such message is coded in a predetermined manner and includes,

2

among other things, a message number that uniquely identifies a message stored both locally at the device and at the user agent, a modifier representing the customization to be applied to the message, and personalized address aliases.

A user agent inside the two-way messaging network, corresponding to a subscriber of a two-way message system, stores among other things, a plurality of messages and destination addresses. When a user agent receives a coded message from its associated subscriber, it expands the message back to the desired full message and destinations by selecting from the stored messages and destination addresses according to the code.

The message that can be transmitted is highly flexible. In addition to fixed pre-canned components, it can include dynamic components such as embedded replies, choices, predefined variables, etc. As an example, consider a stock trading application. A subscriber is notified via two-way messaging when a stock he or she is interested in has reached a particular value. The notification message can embed a reply with choices to buy or sell and predefined variables for entering the number of shares and share price.

The dynamic components allow customization of messages by message senders and recipients, thus greatly increasing the practical applicability of the system. The particular values of the dynamic components are encoded in the message modifier, and are recovered and applied by the user agent.

The coded message is much shorter than the corresponding full-text message, thus allowing reduced bandwidth usage in a wireless communication environment. Together with user agents, the use of coded message is especially suited for communication scenarios in which the bandwidth in the uplink and downlink directions are asymmetric, or the end device is limited by either processing power, memory storage, or battery capacity.

The two-way messaging system of the present invention also can support multicasting. A message can be forwarded to a plurality of destinations for multiple responses. The address alias contained in a coded message can correspond to a single address, a group address or any combination of the two. With multicast, the number of (uplink and downlink) messages required for the transmission of a message is minimized.

In another aspect of the present invention, the system can track and answer queries about transactions. A transaction is a single or a series of request-response interactions between a message sender and recipient(s). A transaction is most useful for communication scenarios in which selective responses are desired. For example, a transaction can specify that a response arriving beyond a certain time limit will not be needed and should be discarded by the system. When combined with multicast, a transaction can specify the desired semantics of the reply. For example, a transaction with ALL semantics specifies that responses from all recipients are desired, while a transaction with OR semantics specifies that a response from any of the recipients will close the transaction. Once a transaction is closed, additional responses will be discarded by the system.

In accordance with another aspect of the present invention, the system functionalities are distributed among a collection of user agents and intelligent servers. The distributed nature enhances the modularity of the system and makes possible the incremental deployment of the system. For example, a provider desiring only the functionalities of user agents but not those of the transaction servers need to only deploy the user agents.

3

The method and system of the present invention can be implemented on top of any two-way messaging transport. This includes dedicated paging networks (e.g., narrowband PCS), cellular short messaging service (e.g., IS-95, IS-136 and GSM), or wireless data transport (e.g., ARDIS).

The servers can be implemented on specialized network servers or intermediate switches.

The messaging device can be a dedicated paging device similar to existing alphanumeric pagers, a unit that attaches to a computing device (e.g., PDAs, laptops), or integrated as part of a communication device (e.g., cellular/PCS phones) or a computing device (e.g., PDAs, laptops).

#### BRIEF DESCRIPTION OF THE DRAWINGS

The foregoing features and advantages of the present invention can be appreciated more fully from the following description, with references to the accompanying drawings in which:

FIG. 1 is a block schematic diagram of a system and method of the two-way wireless messaging system of the present invention showing its use in association with a public switched telephone network, data network, cellular network and a two-way messaging device.

FIG. 2 is another schematic diagram of the two-way wireless messaging system of the present invention.

FIG. 3 is a more detailed view of the two-way wireless messaging system showing various user agents, the messaging network, and examples of messages that can be forwarded among the different subscribers.

FIG. 4 is a schematic view showing the network architecture of the two-way wireless messaging system of the present invention.

FIG. 5 shows an example of the control architecture for the two-way wireless messaging system of the present invention.

FIG. 6 is a block diagram showing an example of the protocol architecture used between the messaging device and the batch server of the two-way wireless messaging system of the present invention.

FIG. 7 is a detailed flow chart showing an example of the protocol flow for new message delivery used with the two-way wireless messaging system of the present invention.

FIG. 8 is a detailed flow diagram showing an example of the reply delivery in the two-way wireless messaging system of the present invention.

FIG. 9 is a schematic diagram of a two-way messaging device in the form of a two-way pager that can be used with the two-way wireless messaging system of the present invention.

FIG. 10 is a schematic diagram of an example of the batch server structure that can be used with the two-way wireless messaging system of the present invention.

FIG. 11 is a schematic diagram showing an example of the functional parts of the user agent that can be used with the two-way wireless messaging system of the present invention.

FIG. 12 is a schematic diagram showing an example of the various functions of the transaction server that can be used with the two-way wireless messaging system of the present invention.

FIG. 12a depicts the open and closed states of the conversation manager.

FIG. 12b depicts the state transition diagram for the recipient states of the transaction server.

4

FIG. 13 shows a schematic illustration of a two-way messaging device where a simulated keyboard is displayed for entering a message.

#### DETAILED DESCRIPTION OF THE INVENTION

Referring to FIG. 1, there is shown at 10 a two-way wireless messaging system of the present invention, which allows an originating message code from a two-way messaging device 11 to be received in a user agent 12 of a two-way messaging network 14. The two-way messaging device 11 is illustrated throughout many of the drawings as a dedicated two-way pager. The two-way messaging device can also be an attachment to a communication device, or even integrated as part of a communication or computing device. A message can be delivered through a public switched telephone network 16 that includes a network access switch 18 connected to a telephone 22 by a first communication coupling 20 through a twisted pair line, co-axial cable, fiber optic line, wireless link or any other type of communication coupling. The messaging network 14 can also be connected to a cellular network 24 or data network 26 for transporting E-mail messages 27 to a desired destination such as a personal computer at a desired time. Additionally, messages could be forwarded to a destination through the world-wide web 27a.

In accordance with the present invention, a second communication coupling 28 connects the network access switch 18 to a Network Control Point (NCP) 30 that is coupled to a database 32 via a third communication coupling 36. The network 16 is coupled to the messaging network 14 via a fourth communication coupling 38. The communication coupling between the two-way messaging device 11 and two-way messaging network 14 is an air interface. The messaging network 14 also may have at least one user agent 12 corresponding to a subscriber 40 (FIG. 2) of the two-way wireless messaging service. The subscriber 40 receives a message from the messaging network 14 along a first communication channel 42. These messages can include transmitted messages or replies. Messages forwarded by the two-way messaging device 11 to the messaging network 14 are forwarded along a communication return channel 43. In the case in which messages and addresses of recipients are coded, messages received by the two-way messaging network 14 are forwarded to a user agent 12.

In accordance with the present invention, the user agent 12 includes a plurality of stored messages. A predetermined message is forwarded to a desired destination such as a data network 26, public switched telephone network 16 or a cellular network 24 in response to an originating message code that is received from a two-way messaging device 11 of the subscriber 40 along the second communication return channel 43. This originating message code is expanded by the user agent 12 so that the downlink message to the desired destination can include full information. Also, the selected destination could be a second two-way messaging device 44 (FIG. 1).

As shown in FIGS. 1 and 2, the services which can use the two-way wireless messaging system 10 vary, and can include services for sending messages to 1) a telephone 22, 2) a computer as E-Mail 27, and another second messaging device, such as a pager 44. The second communication return channel 43 used by the two-way messaging device 11 and any other device not only carries new messages or replies, but also enhances the system 10 capabilities. It can be used for acknowledgements, thus allowing reliable

messaging, and for signaling such as registration or location information, if available. Because the message expands in the user agent 12, the channel bandwidth in the forward and reverse directions differs significantly, as much as a ratio of 100 (or more) to 1. This asymmetry also can exist in terms of processing power, memory storage and battery capacity between the messaging device 11 and the network 14.

For purposes of discussion, a short two-way messaging scenario is first described, followed by a more detailed description of various messaging system elements and their functions.

Referring now to FIG. 3, there is illustrated the two-way wireless messaging system having four user agents for Thomas, Dan, Mary and Paul, referred respectively as UAT 50, UAD 52, UAM 54 and UAP 56.

Thomas can originate through his pager 50a a message to his lunch group members, Dan, Mary and Paul, and inquire about lunch choices. The message is delivered via the two-way wireless messaging network 14 along message delivery channels 57a (air interface), 57b (Data network interface), 57c (telephone network interface) as a page to a two-way messaging device in the form of a pager 58 belonging to Dan, an electronic mail to a computer 60 belonging to Mary, and a phone call to telephone 62 belonging to Paul respectively. The reply from each recipient is collected by the two-way messaging network 14 along a respective message return communication channel 64a, b, c and forwarded back to Thomas via the first communication channel 42 as a page. The type of message return communication channel 64a, b, c and message delivery channels 57a, b, c vary depending on the device, such as a pager 58, computer 60 or phone 62.

In accordance with the present invention, the uplink messages are kept short because of the use of the user agents 50-56. The user agents mirror the state and context (e.g., any address and message tables in the user agent) of their messaging devices 11 (FIG. 1), 50a, 58. In the above example, the uplink message contains a short group identifier and a message number. These are used by the user agents as indices to respective data tables in message expansion. For message reply, the uplink message contains only a reply code. This is expanded back to the full reply inside the network. By using group addressing, Thomas sends only one message uplink and the network automatically "copies" the message to the multiple recipients at the predetermined destinations.

Dan, Mary and Paul each receive the message in a different format, which could have been proposed by Thomas during message origination or specified as part of the filtering/forwarding criteria of the respective user agents of the recipients.

The criteria for filtering/forwarding can be very general. It could be based on the message originator, time of day, or any other commonly available forwarding options. Messages can also be formed in a variety of techniques. For example, Thomas can send the message as a pre-canned message with an embedded response. Thus, the message would include not only the text of the request, but would also include a list of responses to be selected and returned by the recipient.

Any user agent, e.g., those depicted as items 50-56, typically maintains, among other things, an identical copy of the address and message tables as the messaging devices. The address and message information stored in the messaging device and respective user agent should always be consistent with each other. Typically, to change these

address and message tables, a subscriber needs to change one copy first and the system will propagate the changes to the other.

There are various methods a subscriber to the messaging system can use to enter new messages or addresses. There are chiefly two main categories, i.e., through the messaging device itself, or through the messaging system.

For example, as illustrated in FIG. 13, the messaging device 11, e.g., a two-way pager, can include a simulated keyboard 69 displayed on the LCD screen 88. A subscriber uses the pager buttons 84 to navigate around the simulated keyboard and select characters to compose a message. This method is tedious and applicable more to short, fixed messages. This method is not practical for making flexible messages that contain dynamic components.

A subscriber can also elect to add an incoming message sent by others to its own set of messages. For example, the subscriber will receive an incoming message from another individual. The subscriber may like that particular message and through an appropriate selection of buttons on the messaging device 11, add that message to his or her own message list.

In still another method, many existing messaging devices such as pagers, have an input/output (i/o) port. This port could be used to connect to a laptop or a Personal Digital Assistant. A subscriber uses the laptop or PDA to edit messages and download them to the messaging device 11 via the input/output port. An appropriate protocol could be used.

The other major category is to use the messaging system for updating any new messages and addresses to the subscriber user agent. For example, new messages and addresses are directed to the user agent. This is one way to customize a subscriber's message and address set. The copy in the subscriber user agent is updated such as by using a dial-up program, an internet connection, a world-wide web page or even an operator to change the messages and addresses directly via wireline.

In still another method, the subscriber signs up for a new third-party service. When the subscriber initially signs for that service, the subscriber is given a set of messages and addresses that are used to access the service. These messages and addresses are then loaded directly into the subscriber's user agent by the service provider.

In the following, a more detailed description of a user agent 12 (FIG. 1) and its function relative to the two-way wireless messaging system 10 (FIG. 1) is set forth.

In accordance with the present invention, each subscriber of the two-way wireless messaging system 10 is represented by a user agent 12 that resides inside the messaging network 14. The user agent 12 expands coded originating messages received from a two-way messaging device and provides pointers to the last known location of the two-way messaging device 11. It also maintains the status of the two-way messaging device 11, i.e., if it is on-line, and a profile of the subscriber. The user agent 12 also can provide some value-added functions such as message screening and selective message forwarding. The user agent 12 may also be customized by its subscriber 40. Thus, the user agent 12 acts as a personal server for the subscriber 40.

The user agent 12 also provides other benefits. Because messages are expanded inside the messaging network 14, the bandwidth on the uplink can be reduced, allowing bandwidth asymmetry on the wireless link. By performing intelligent processing in the network instead of at the end device 11, the enhanced power of the network is utilized. The user agent 12 manages mobility by tracking the location

of the subscriber. Finally, the user agent 12 serves as a proxy for the two-way messaging device 11 when it is out of range, allowing the system 10 to account for disconnected users.

As shown in FIG. 11, the user agent 12 can have respective fixed and extensible parts 70, 72. The fixed part 70 implements basic messaging functions that are generic for all user agents. It can mimic the context of a messaging device, (e.g., the address table and the message table) and maintains information about ongoing message delivery. The extensible part 72 includes user agent programs 72a, 72b, it can be programmed to perform specific tasks as desired by the subscriber 40 (FIG. 1), e.g., maintaining a personal calendar, retrieving specific information from a world wide web page 27a, a database 73, where data can be input 73a, or other similar functions. The software 74, is associated with the user agent program to provide run time support for the system.

These basic functions include registration/deregistration, message delivery and message status query.

In registration the current location of the two-way messaging device is updated to the system as shown in FIG. 4. Registration can be explicit or implicit. Explicit registration occurs when a messaging device is powered-up or when it moves into a new cluster 78 (FIG. 4). Implicit registration occurs when a message is received or delivered to a messaging device. During power-up the user agent 12 can also download messages that have been received in the messaging network 14 since the last power-down of the two-way messaging device.

The user agent 12 allows message delivery:

- (1) when the device originates a new message;
- (2) when the device receives a message;
- (3) when the device replies to a message; and
- (4) when the device receives a reply.

Processing for groups 3 and 4 closely resembles that of groups 1 and 2.

When a messaging device 11 originates a new message, the user agent 12 translates the destination and reply address aliases sent by the device into the full address and expands the supplied message number and modifier into full message text and creates a record for the message. This record can be used as a basis for any subsequent message query. When a messaging device 11 receives a message, the user agent 12 returns the current status (on/off) and location of its device. Certain personal messaging functions, e.g., forwarding or filtering can also be performed.

For message status query, the query request is answered by the user agent by consulting its message record and if necessary, a transaction server is consulted about current delivery status, as will be explained later.

The extensible portion of the user agent specifies a framework in which additional functions can be added as user agent program modules 72a, 72b (FIG. 11). This collection of programs contain codes to handle messages of a specific pattern. The extensible part 72 follows an event-driven model and provides a kernel that pattern-matches incoming messages and dispatches them to an appropriate program module. Also, the extensible part 72 can be used for signaling by addressing a message to the user agent itself. For example, a message status query can be implemented as a signaling function in the extensible part.

Referring now to FIG. 4, there is illustrated a basic architecture of the two-way wireless messaging system 10 of the present invention. As illustrated, the system 10 includes a three-tier hierarchy. The highest is a domain 80; the cluster 78 is the middle; and the cell 82 is the lowest. The coverage

area of a base station 76 defines a cell 82. A collection of adjacent cells 82 form a cluster 78 and a collection of clusters form a domain 80. Three domains are illustrated. A domain 80 is an administrative unit and each subscriber is associated with a unique domain called the "home domain". The various servers of the present invention 10 are replicated in each domain 80 and the user agent of a subscriber resides and is managed by its home domain. For purposes of description only one single domain is described. This hierarchy is designed for several important principles in the present invention:

- (1) limiting the control information transmission;
- (2) limiting the size of transmitted messages; and
- (3) distributing functions in a modular manner.

To limit the transmission of control information by a two-way messaging device 11, the amount of periodic signaling is reduced. For example, location updates can be minimized by defining the registration area to be a cluster 78. Thus, the two-way messaging device 11 only re-registers with the system 10 when it crosses cluster boundaries. This can reduce the amount of signaling traffic, especially in a microcell infrastructure with high subscriber mobility. Thus, the messaging network only knows the location of a messaging device to the resolution of a cluster 78, and a limited search is necessitated to locate a device 11 before message delivery.

A small cluster 78 size provides better precision of device location and a smaller messaging delay at the expense of more frequent updates. A larger cluster size, on the other hand, increases average messaging delay but requires less frequent updates. To obtain an optimal cluster size, both message arrival rate and mobility pattern should be considered.

Referring now to FIG. 9 there is illustrated one example of a messaging device that can be used with the present invention. It is illustrated as a dedicated, stand alone two-way pager 11. In this example, the messaging device 11 generates, receives and displays messages to the subscriber user. The design of the messaging devices must take into account important hardware limitations, such as the need for minimum power consumption. As illustrated, the messaging device 11 should be business card size to provide the portability required of "any time, anywhere" service. The power consumption should be minimum, requiring infrequent battery change.

FIG. 9 shows a representative schematic of a pager 11 having four function buttons 84 at the bottom serving as soft keys, i.e. keys whose functions vary with the contexts, and two buttons 86 on the side, used mainly for scrolling purposes. The two-way pager includes a 5-line LCD screen 88 in which the top four lines are used for text while the bottom line shows current bindings for soft keys. The pager contains computing hardware, e.g., a processor and memory for user interface code and pager protocol. A low power general purpose microprocessor can be used for the pager. Memory should be adequate enough to contain these various messages and associated data.

As shown in FIGS. 2 and 4, a base station 76 terminates the air interface and a link layer protocol with the pager 11. It manages the air interface resources. Base stations 76 can be deployed as cellular base stations, packet radios or other types of transceivers as required for any wireless messaging and paging systems.

Referring now to the general overview of FIGS. 4 and 5, there now follows a description of the various servers used with the two-way wireless messaging system of the present invention.



A batch server **100** provides intelligence to base stations **76**. A single batch server **100** connects to one or more base stations **76**, and receives and acknowledges messages from the messaging device **11**. It also receives messages destined to a messaging device, forwards them to the proper base station **76** for delivery, and receives acknowledgements that the messages have been correctly received. The batch server **100** may batch downlink pages into groups for scheduled delivery to allow sleep mode operation of pagers. In essence, a batch server **100** acts as a point of transfer between the wired (network) and the wireless (subscriber and base station) portions of the system **10**. It is responsible for relaying uplink messages from subscriber devices (via base station **76**) to the network and downlink messages from the network to subscriber devices (via base stations **76**).

A protocol structure that can be used for interactions between the pager **11**, base station **76**, and batch server **100** is shown in FIG. 6. The Message Layer Protocol (MLP) **102** is responsible for ensuring reliable message delivery between the batch server **100** and a messaging device. Each MLP **102** data unit contains one user-level message. At most one message per messaging device may be outstanding at a time. The sending entity of a message maintains a retransmission timer for the outstanding message, and retransmits the message until it receives an acknowledgement. Acknowledgments are generated by the receiving MLP entity when a message is correctly received.

The Airlink Specific Convergence Sublayer (ASCS) **104** operates peer-to-peer between the batch server **100** and the messaging device **11**. The ASCS **104** is responsible for segmenting MLP **102** data units into the appropriate size for transmission over the air interface, and re-assembling air interface frames into MLP data units at the receiver. ASCS **104** passes only correctly received data units to an MLP; any corrupted data units are silently discarded. The ASCS protocol specification is dependent on the air interface protocol, and as a result, many different ASCS's will exist.

Two link layer protocols **106**, **108** are illustrated. LINK1 **106** operates between the batch server **100** and the base station **76**. LINK2 **108** operates over the air interface and is specified by the particular air interface used in the system **10**.

The high-level structure of a batch server is shown in FIG. 10. It maintains a number of data structures for its operation such as a registered messaging device table, which maintains a record for each messaging device currently being served by the batch server. The record includes both information about the messaging device (i.e., last base station visited) as well as traffic statistics (e.g., number of uplink/downlink messages from/to a messaging device). The wireline (network) side is indicated generally at **109**, and the wireless (subscriber and base station) side is indicated generally at **109a**.

A record is created in the registered messaging device table under two circumstances: an explicit registration or an implicit registration. An explicit registration in turn is performed under two conditions: power up initialization or cluster boundary crossing. The former is a new registration while the latter is a re-registration. A re-registration requires the additional step of deleting the state information kept in the old batch servers. An implicit registration, on the other hand, occurs when a base station receives a data message from a messaging device not currently registered. This is often the result of an active messaging device moving between cells in a cluster, and then sending or receiving a message. The record is deleted when a power-down deregistration is received.

Another data structure is Unacknowledged Message Queues (UMQs) **110**, which contain messages that are to be delivered on the downlink. They are logically organized on a per messaging device basis, though the actual implementation may be based on separate queues or a common message pool. The batch server **100** uses a stop-and-go strategy in delivering the messages, i.e., it will not deliver a new message to a messaging device **11** until the previous message to the messaging device has been acknowledged. Thus, at any particular time, there is at most one outstanding unacknowledged message.

When an acknowledgement is received from a messaging device, the acknowledged message (i.e., the message at the head of the queue) is moved to the Acknowledged Message Queue (AMQs) **112**. The acknowledgement is designed to be short; it contains only a so called receive buffer index (rbi), which is a locally unique (relative to the destination pager) identifier. The rbi is used later to correlate the reply to the original message.

Another data structure is the Acknowledged Message Queues **112**, which contain messages whose delivery has been acknowledged by the destination messaging devices and are currently awaiting their replies. A reply contains an rbi together with a reply code. The rbi is used to retrieve the original request; it serves essentially as a local message id, thus eliminating the need to send the system message id uplink. The reply code encodes the desired response, and is to be expanded by the replier's user agent.

Generally, the length of these queues is small because replies tend to follow the acknowledgements closely, in the order of about **30** minutes. A procedure could exist and be implemented by one skilled in the art to migrate the state back to the user agent if a reply does not come within a certain time limit. Thus, the AMQs behave like a cache for storing message information needed in processing a reply.

Depending on the air interface, the batch server **100** may also be responsible for other low-level tasks. These include the delivery of packets using a multicast operation. There are two possible forms of multicast delivery: 1) true and 2) ad-hoc. In a true multicast, messaging devices belonging to a multicast group share a single multicast address and messages are delivered using the multicast address. In an ad-hoc multicast, an address header message containing a list of destination device ID's is first sent to alert the receiving messaging devices. This is then followed by the actual body of the message.

Referring again to FIGS. 4 and 5, there is illustrated a messaging server **114**, which enhances the modularity of the system by coordinating activities of individual servers. The messaging server **114** receives originating messages, coordinates with other servers to determine their location and format in which the message should be delivered, invokes value-added services and finally routes the messages to a server which can deliver them. The messaging server **114** functionality is required in all messaging systems and its operation varies depending on the intelligence and value-added services available from the messaging system.

The distribution server **116** is responsible for delivering messages to their final destinations in the proper format. For messages to be delivered to a wireless device such as a pager **11**, the distribution server **116** executes a direct paging algorithm based on location information provided by a user agent **12**. For messages that are to be translated into a different format, the distribution server **116** routes the message to a translator. The distribution server functions are basically required in the system **10**. If the system **10** does not make use of location information, but floods the air inter-

## 11

faces with messages to be delivered (true broadcast), the distribution server function is minimal.

The distribution server 116 works in conjunction with a user agent 12 that supplies location information, and manages user mobility in the present invention. The distribution server 116 forwards any message to be delivered to the batch server 100 that was last known to have been serving the messaging device, such as a pager 11 or other wireless device. If the batch server 100 successfully delivers the message, the distribution server 116 receives an acknowledgment and the algorithm terminates. If the batch server times-out, the distribution server 116 will forward the message to all batch servers 100 which neighbor the original target batch server. This increases the coverage area in which the message delivery is attempted. The message is not sent to the original batch server on the second delivery attempt. If the message is still not delivered, the coverage area is increased again, sending to neighboring batch servers 100 of the latest subset until the message is delivered.

This algorithm has several benefits. First, no single batch server 100 is included twice in the search. Second, while the distribution server 116 performs directed paging on a cluster area, the batch servers 100 may execute a directed paging algorithm among the base stations 76 within the cluster 78. This distributed control allows base stations 76 to be added to clusters without requiring the distribution server 116 to change its directed paging algorithm search lists. The directed paging algorithms of the system 10 are designed to reduce both the air and network traffic in the paging system 10 when compared to the flooding techniques employed by many paging systems in operation today. Many variations of this basic algorithm are possible to those skilled in the art.

The transaction server 118 (FIGS. 4, 5 and 12) tracks the transactions between messaging subscribers. This involves correlating messages, replies, and acknowledgments. The transaction server 118 supports several transaction types, reports the status of transactions when requested, and closes transactions when complete. It supports one-to-one and one-to-many transactions. For example, a subscriber 40 (FIG. 2) may send a message to three endpoints and request that it be only notified of the first response. In this case, the transaction server 118 will open a transaction when the message is sent, and close it when the first reply is received. Any further replies will be discarded. If a system does not support transactions, the transaction server 118 is not a required element.

In the system of the present invention, the transaction server 118 supports the following basic transaction types which may be combined to form a more enhanced set of transaction services:

1. All-reply
2. N-reply
3. Timed-reply

The all-reply transaction remains open until a reply has been received by every message recipient. The N-reply transaction remains open until a reply has been received by N message recipients. The timed-reply transaction remains open until a user specified time has expired. Once a transaction is closed, further replies are not accepted and not forwarded to the transaction originator. For example, in a transaction in which only the first three replies are accepted within five minutes, if either five minutes elapses, or three replies are received, the transaction is closed. This is an example of combining the N-reply and Timed-reply transaction types. All transactions are subject to a system timer which is used to close transactions that have not been completed within a reasonable amount of time.

## 12

A schematic diagram of one example of the structure of the transaction server is shown in FIG. 12. As noted before, the transaction server 118 supports three basic transaction types: all-reply, N-reply, and timed-reply.

As shown in FIG. 12, the transaction server has two levels of hierarchy: a conversation manager 120 and a transaction manager 122. The conversation manager 120 maintains a simple two-state machine as either open 124 or closed 126 (FIG. 12a). If a transaction is open, replies to the original message are expected and accepted. If the transaction is closed, no replies are accepted. The transaction manager 122 is responsible for tracking the state of each recipient involved in the transaction, and thus determine if a transaction should be closed. The transaction manager makes this decision based on the number of replies that are being accepted for a transaction, and the number of recipients 128 that have reached the done state as shown in FIG. 12b. When the proper number of recipients are in the done state, the transaction manager informs the conversation manager 120 to close the transaction.

Consider a simple transaction with three recipients. The transaction server receives an OPENTX (open transaction) request from the messaging server 114, and assigns a unique transaction ID to the transaction. It then initiates a conversation manager 120 to handle this request. The conversation manager 120 is indexed by the transaction ID. The conversation manager 120 transitions into its open state and initiates a transaction manager 122. The transaction manager 122 creates three records, one for each recipient, to reflect the recipient states. The records are indexed by the recipient address. The initial states are the states labeled by "sent", signifying that the message is being sent to all three recipients.

The transaction server 118 also stores information concerning the transaction type. For example, the transaction server 118 determines from the transaction type how many replies should be accepted for the transaction. The transaction server also sets a deadline timer by which time the transaction must be closed. If the transaction is not a timed transaction, a default system timer, typically on the order of a day, is used. At this time, the transaction server 118 replies to the messaging server with the transaction id.

As acknowledgements and replies are received from the message recipients, the conversation manager 120 maintains the transaction in its open state. The transaction manager 122 modifies the state of each corresponding recipient. As acknowledgements are received for the replies, the transaction manager 122 will transition the appropriate recipients to the done state. Depending on the number of replies allowed for the transaction, the transaction server 116 determines if more replies should be accepted. When the reply limit is reached, i.e., the required number of recipients have reached the done state, the transaction manager 122 instructs the conversation manager 120 to close the transaction. The transaction manager 122 may also instruct the conversation manager 120 to close the transaction if the transaction time has expired.

After this time, any replies received by the transaction server 118 are rejected. The transaction server sets a record timer. Until the timer expires, the state of the conversation manager is frozen in the closed state, and recipient states are frozen. During this time, the transaction server 118 may be queried as to the state of the transaction. When the record timer expires, the transaction server 118 deletes the conversation manager 120 and transaction manager 122 for the transaction. Any queries to the transaction server 118 after this time will result in an invalid transaction ID message.

13

A simple routine flow chart is shown in FIG. 12b and illustrates message transmission and acknowledgements. A message is sent 130 and acknowledgement received 132. A reply is received from the recipient 134 and then the sequence is done 136 when the acknowledgement is received for a reply.

The two-way wireless messaging system 10 with the present invention allows various types of messages. Unlike many existing paging and messaging systems which support primarily static messages, or require dictations, the present invention supports flexible message types. The design of these message types is strongly influenced by the capability of the messaging device. For example, the lack of a keyboard implies that free form messages are impractical. Also, as many of the advanced features are processed locally by the messaging device, the device must be sophisticated enough to handle the processing logic.

The most basic type of supported message is fixed pre-canned messages. This is identical to what is currently available under one-way alphanumeric paging. A simple extension of fixed pre-canned messages is the so-called richtext messages. It adds text attributes, e.g., bold face, inverse video, etc., to the plaintext of fixed pre-canned messages. Fixed pre-canned messages suffer from a major limitation, namely, they cannot be dynamically customized. To overcome this, the present invention introduces three types of dynamic components: 1) optional components, 2) selections and 3) pre-defined variables. Optional components delineate message parts that can be dynamically included or excluded. A selection provides a list of items from which to choose. For example, a selection labeled "location" may expand into the list of choices: a) home, b) office, or c) lab. The set of available selections are defined by the individual subscribers. Pre-defined variables represent specific commonly used entries that can be customized by a user. Typical examples of pre-defined variables are time, phone number, etc. Dynamic components can be nested as needed.

To facilitate a reply, a message can include reply components. A reply component embeds the desired replies, typically making use of dynamic components. This is useful in applications where the possible replies are agreed upon a priori.

The most general message type includes conditional components. A conditional component can be conditionally included or excluded based on the values of previous dynamic components. It can be used to chain multiple messages together, thus eliminating the roundtrip delay. They are intended only for the most advanced messaging applications.

Described below is an example of a protocol flow for a multicast message delivery with replies. Focus is directed on the salient features of the system.

In the example, presented in FIGS. 7 and 8, a subscriber S 200 sends a message to three recipients, R1 202, R2 204, and R3 (not shown). In this example, R1 last registered at BS-R1, 222 and is still currently in BS-R1. R2 last registered in BS-R21, 230, and has since moved to BS-R22, 232. R3 is currently inactive, i.e., power off. R1 202 receives the message on its messaging device in the first delivery attempt. R2 204 receives messages on its messaging device on the second delivery attempt. R3 requests that the message be forwarded to a message storage server for subsequent retrieval. In the following, we illustrate the function of each entity, the location management procedures of the system, and a direct paging algorithm. The interaction with individual base stations is not included in this example. It is

14

assumed that there is a one-to-one mapping between base stations and batch servers for simplicity.

FIG. 7 shows a highly schematic depiction of message delivery procedures. The originator of the message, S 200, transmits its message into the network through its serving batch server, BS-S 208, via a PG2BS-NEW message. This PG2BS-NEW contains the address of S, an array of recipient addresses, an array of reply-to-addresses, and the coded message. In this example, the recipients listed are R1 202, R2 204, and R3 206, and the reply-to-address is the address of the message originator, S 200. The message is coded by indicating a message number and any dynamic component values. BS-S 208 receives the message, and generates an acknowledgment back to S 200, BS2PG-ACK (shown by the reversed arrow), signifying that the network has accepted the message for delivery.

The batch server 208 forwards the message to the messaging server, MS 210, in a BS2MS-NEW message. In addition to the information contained in the PG2BS-NEW message, this message contains a message identifier (mid), which uniquely identifies this message throughout the system.

The messaging server 210 contacts the user agent of the message originator, UA-S 212, with a MS2UA-NEW message. UA-S 212 performs the message expansion function. It expands the message body depending on the message number and dynamic component values received and expands any address aliases into the full system addresses. UA-S 212 responds to the messaging server 210 with the message body and the message type, i.e., an indication if this message requires a reply, if it is part of a transaction, or if it is a simple one-way page. In this example the message is classified as a transaction in which replies from all recipients are required. This information is sent in the UA2MS-NEW message.

As this point, the messaging server 210 contacts the user agents of the message recipients to determine the location of their corresponding messaging devices, the format in which they wish to receive the message, and their status. It does this by sending HDR messages to the user agents. The user agents respond with the status and last known location of the messaging devices. In this example, UA-R1 214 responds that the messaging device is active, and that its last known location is BS-R1. UA-R2 216 responds that the messaging device is active, and that its last known location is BS-R21. UA-R3 218 responds that its pager is off, and that the message should be forwarded to a message storage server.

The messaging server 210 receives these replies, and then requests that the transaction server 220 open a transaction for this message exchange via the OPENTX message. The transaction server 220 opens the transaction, and returns a transaction ID in the TXRSP message. The transaction ID uniquely identifies this transaction throughout the network, and furthermore, identifies the transaction server 220 managing this transaction. The transaction ID is forwarded to the user agent 212 of the message originator (TXUPDATE) so that it may access the transaction record if it later receives any queries as to the status of the transaction.

The messaging server 210 then forwards the full message body, along with the list of recipients, their desired message formats, and last known locations to the distribution server 221 (MS2DS). The distribution server 221, based on the location information provided, and the desired format of the message, determines how to deliver the message to the recipients. It forwards the message to R1 202 via BS-R1 222, and the message to R2 204 via BS-R21, 230 as instructed by the location information received. It forwards the message for R3 to the message storage server, MSS 224.

16

BS-R1 222 delivers the message to R1 202 (MSG), and eventually receives an acknowledgement (ACK). The batch BS-R1 222 server forwards this acknowledgement to the distribution server 221, which forwards the acknowledgement to the transaction server 220. The transaction server 220 updates its transaction record.

Likewise, an acknowledgement is received from the message storage server 224 on behalf of R3. This acknowledgement is also forwarded to the distribution server 221 and transaction server 220. In addition, the distribution server 221 updates UA-R3 218, notifying it of the retrieval ID by which the user may retrieve the message from storage at a later time (UPDATE). The retrieval ID is downloaded by UA-R3 218 to R3 when R3 powers on.

The batch server BS-R21 230 does not receive an acknowledgement for R2 204, and therefore times-out. It generates a negative acknowledgement to the distribution server 221 (NAK). The distribution server 221 executes the directed paging algorithm in which it expands the message delivery area to all batch servers neighboring the original target. In this example, these are BS-R22 232 and S-R23 234. BS-R22 232 successfully delivers the message and receives the acknowledgement. The acknowledgement is forwarded to the distribution server 221 and transaction server 220. The distribution server 221 updates UA-R2 216 so that it may reflect the current location information of R2 204. It is through this interaction between the distribution server and user agents that the approximate location of the wireless messaging devices is learned, and the direct paging algorithm is executed.

At this time, the message has been delivered to all recipients, and the transaction is open.

FIG. 8 shows the flow for the reply to a message generated above. At a high level, the reply flow is symmetrical to the message origination flow. In this example, the recipient, R 240 generates the reply (REPLY), which is received by batch server BS-R 242. The reply is again a coded message, with an identifier to associate it with the original message. The batch server 242 caches information about messages it delivers for a finite time. If the reply is received by the batch server 242 within that time period, it can determine the full message ID, transaction ID, and other ID's, from a local identifier. If the information has been removed from the cache, or if the wireless messaging device has moved to a different batch server area before sending its reply, the batch server 242 must fetch the information from the user agent of the wireless messaging device sending the reply.

As in the message origination case, the batch server forwards the message to the messaging server 244 which contacts the user agent of the replying device 246. The user agent 246 expands the reply, and returns the message to the messaging server. The messaging server 244 then contacts the transaction server 248 to notify it that a reply has been generated. If the transaction is still open, and more replies are still being accepted, the transaction server 248 instructs the messaging server 244 to continue delivering the reply, as in this example. The remaining portion of the reply delivery flow is similar to the message delivery flow: the user agent 246 of the device receiving the reply is contacted to determine where to deliver the reply, and the reply is sent to the distribution server 250 for delivery.

When the acknowledgement for the reply is received by the distribution server 250, it is forwarded to the transaction server 248.

The two-way wireless messaging system with the present invention can be used with more than the above-illustrated

examples. For example, it is conducive for dispatching where a dispatcher may transmit a message to a group of recipients in order to assign a task. For example, a maintenance supervisor can send a message to all shift workers if an outage occurs. The message recipients respond upon receiving the message indicating their availability. The supervisor may then assign a job to one or more members of the group.

Additionally, the two-way messaging system can be used as a calendar reminder service where reminders and alarms are generated by a network-based calendar server with the help of subscriber user agents. The messaging devices are portable, and messages can be delivered to a pager, E-mail and other messaging device. The calendar can act somewhat as an "alarm" and notify a user at any time of scheduled appointments, anniversaries and important dates. Appointments can be entered into the calendar as part of the user agent.

Additionally, the system can be used for emergency signaling and sending a S.O.S. message. In an emergency signaling system, a person in distress can send an S.O.S. message. This message is routed to an emergency command center. The network can indicate the location of the sender of the message using a location-based service system. The emergency command center may send messages to the person in distress to perform an initial evaluation of their condition through the use of query messages. For example, messages such as "Are you injured?", "Are you bleeding?", or "Can you move?" may be sent with reply choices. Answers collected from the initial evaluation can be extremely useful in dispatching the proper emergency response units.

Upon finishing dispatching (via a separate two-way message multicast as described earlier), an acknowledgment such as "Help is coming" or "Please meet the ER people at the next block" can be relayed back to the person requesting emergency help.

Depending on the subscriber's profile, a follow-up notification via two-way messaging could be sent to the family members of the subscriber.

This service takes advantage of the reliability, bidirectionality, multicast, and transaction support of the two-way messaging system.

Additionally, messages may be directed to subscribers in a certain location. For example, if the trains in New York are not running, all people in New York may be sent a message. This service is similar to current simple paging services except that it is location dependent.

While the best mode for carrying out the invention has been described in detail, those familiar with the art which the invention relates will recognize various alternative designs and embodiments practicing the invention as defined by the following claims.

That which is claimed is:

1. A two-way wireless messaging system, comprising:

a messaging network having a first user agent corresponding to a first subscriber of a two-way wireless messaging service, wherein a first pager of said first subscriber receives messages from the messaging service along a first wireless communication channel that wirelessly couples said messaging network and said first pager of said first subscriber,

said first pager including a plurality of messages stored therein and corresponding message codes;

## 17

first air interface between said first pager and said messaging network;  
 wherein said first wireless communication channel crosses said first air interface;  
 said first user agent including a plurality of messages stored therein and corresponding message codes that are identical to said messages and codes in said first pager, wherein a predetermined message stored in said first user agent is forwarded to a desired destination in response to an originating message code corresponding to said predetermined message that is received from said first pager of said first subscriber along a second wireless communication channel that wirelessly couples said messaging network and said first pager of said first subscriber;  
 wherein said second wireless communication channel crosses said first air interface;  
 a second user agent in said messaging network corresponding to a second subscriber of said two-way wireless messaging service and through which said predetermined message is forwarded to said desired destination;  
 a second pager of said second subscriber receiving said predetermined message from said second user agent along a third wireless communication channel that wirelessly couples said messaging network and said second pager of said second subscriber;  
 a second air interface between said second pager and said messaging network;  
 wherein said third wireless communication channel crosses said second air interface;  
 said second user agent receiving a reply code from said second pager of said second subscriber indicating additional action;  
 wherein said reply code is received by said second user agent from a fourth wireless communication channel;  
 wherein said fourth wireless communication channel crosses said second air interface.  
 2. The two-way messaging system according to claim 1, wherein:  
 said originating message code includes a message that is expanded by said first user agent.  
 3. The two-way messaging system according to claim 1, wherein:  
 said first user agent includes a fixed portion where basic messaging functions generic to all user agents are implemented.  
 4. The two-way messaging system according to claim 1, wherein:  
 said first user agent includes an extensible portion for performing specific tasks as desired by said first subscriber.  
 5. The two-way messaging system according to claim 1, wherein:  
 said first user agent includes stored addresses corresponding to a destination alias in the originating message code.  
 6. The two-way messaging system according to claim 1, wherein:  
 said originating message code includes a modifier for modifying the predetermined message that will be forwarded to a desired location.  
 7. The two-way messaging system according to claim 1, wherein:

## 18

said first user agent maintains location information of the first pager of the first subscriber.  
 8. The two-way messaging system according to claim 1, wherein:  
 said messages stored within the first user agent can be updated and changed by the first subscriber.  
 9. The two-way messaging system according to claim 1, wherein:  
 said messages stored within said first user agent can be updated and changed from information transmitted by the first subscriber along the second wireless communication channel.  
 10. The two-way messaging system according to claim 1, wherein:  
 said first pager includes means for displaying a simulated keyboard such that messages can be input through the simulated keyboard.  
 11. The two-way messaging system according to claim 1, wherein:  
 messages stored with said first user agent can be updated from messages the first subscriber receives.  
 12. The two-way messaging system according to claim 1, wherein:  
 said first pager includes an input/output port that can be connected to a source of download information such that messages and addresses can be downloaded to the first pager.  
 13. The two-way messaging system according to claim 1, wherein:  
 messages stored within said first user agent are updated through said messaging network.  
 14. The two-way messaging system according to claim 1, wherein:  
 said first user agent includes at least one group address corresponding to a plurality of destinations to which a predetermined message will be forwarded.  
 15. The two-way messaging system according to claim 1, wherein:  
 a message forwarded by the first user agent to said desired destination includes a response from the recipient and forwarded back to the first user agent for transmittal to the first subscriber along the first wireless communication channel.  
 16. The two-way messaging system according to claim 15, wherein:  
 a response includes dynamic components that can be customized by the recipient for forwarding back to the first subscriber.  
 17. The two-way messaging system according to claim 1, wherein:  
 a message can be forwarded to a plurality of destinations for multiple responses and the system is selective for transmitting only the desired responses back to said first pager along the first wireless communication channel.  
 18. The two-way messaging system according to claim 1, wherein:  
 said first user agent stores calendar information and delivers calendar reminders to said first subscriber.  
 19. The two-way messaging system according to claim 1, further comprising:  
 a plurality of base stations through which messages to and from the messaging network are received, and a batch

## 19

server associated with at least one of said plurality of base stations for receiving and acknowledging messages and forwarding messages to and from the messaging network.

20. The two-way messaging system according to claim 19, further comprising:

a messaging server in association with said first user agent for determining the location and format in which a message should be delivered.

21. The two-way messaging system according to claim 19, further comprising:

a distribution server working in association with said first user agent for routing messages to their final destination based on destination information received from the first user agent.

22. The two-way messaging system according to claim 19, wherein:

said messaging network includes a plurality of user agents corresponding to respective subscribers for each user agent, wherein said subscribers send and receive messages between each other, and including a transaction server for tracking message transactions among the subscribers.

23. A method for two-way messaging, comprising the steps of:

storing a plurality of messages and corresponding message codes within a first pager,

storing a plurality of messages and corresponding message codes that are identical to said messages and codes in said first pager within a first user agent of a two-way messaging network, the messages corresponding to those selected by a first subscriber of a two-way messaging service,

transmitting messages from said two-way messaging network to said first pager of said first subscriber along a first wireless communication channel that wirelessly couples said two-way messaging network and said first pager of said first subscriber,

wherein a first air interface separates said first pager and said messaging network;

wherein said first wireless communication channel crosses said first air interface;

transmitting an originating message code from said first pager of said first subscriber to said two-way messaging network along a second wireless communication channel,

expanding the originating message code into one of said plurality of messages that corresponds to said originating message code within said first user agent in response to receiving said originating message code from said first pager,

forwarding said one of said plurality of messages through a second user agent in said two-way messaging network corresponding to a second subscriber of said two-way messaging service to a desired destination based on the content of the originating message code,

wherein a second pager of said second subscriber receiving said one of said plurality of messages from said second user agent along a third wireless communication channel,

wherein a second air interface separates said second pager and said messaging network;

transmitting a reply code indicating additional action along a fourth wireless communication channel to said second user agent;

## 20

wherein said fourth wireless communication channel crosses said second air interface.

24. A method according to claim 23, further comprising the step of:

displaying a simulated keyboard on said first pager, and including inputting the messages through the simulated keyboard.

25. A method according to claim 23, further comprising the step of:

updating the messages stored within said first user agent from received messages.

26. A method according to claim 23, further comprising the step of:

downloading information through an input/output port for updating messages and addresses in said first user agent.

27. A method according to claim 23, further comprising the step of:

updating the first user agent through information received from said first pager.

28. A method according to claim 23, further comprising the step of:

updating the first user agent through information received from the two-way messaging network.

29. A method according to claim 23, further comprising the step of:

expanding a destination alias in the originating message code to a list of destination addresses.

30. A method according to claim 23, further comprising the step of:

originating messages having dynamic message components that include optional components, user defined selections, predefined variables and conditional components.

31. A method according to claim 23, further comprising the step of:

determining and maintaining within the first user agent the status of said first pager as either on or off and delivering messages accordingly.

32. A method according to claim 23, further comprising the step of:

receiving any messages in a preferred delivery format as established by said first user agent.

33. A method according to claim 23, further comprising the step of: sending messages in a preferred delivery format as established by said first user agent.

34. A method according to claim 23, further comprising the step of:

filtering messages and replies to and from said first pager based on predetermined criteria stored within said first user agent.

35. A method according to claim 23, further comprising the step of:

forwarding messages and replies to said desired destination based on forwarding information stored within said first user agent.

36. A method according to claim 23, further comprising the step of:

maintaining within the first user agent the status of a message from its origination to its destination.

37. A method according to claim 23, further comprising the step of:

**21**

downloading messages stored within said first user agent to said first pager after said first pager is turned on.

**38.** A method according to claim **23**, further comprising the step of:

accessing said first user agent for changing, adding and deleting information by a computing or communication device.

**39.** A method according to claim **23**, further comprising the step of:

**22**

implementing basic messaging functions within said first user agent that are generic for all user agents.

**40.** A method according to claim **23**, further comprising the step of:

programming an extensible part of said first user agent for performing specific tasks as desired by said first subscriber.

\* \* \* \* \*



US005588009A

# United States Patent [19] Will

[11] Patent Number: **5,588,009**  
[45] Date of Patent: **Dec. 24, 1996**

[54] **PERSONAL PAGING, COMMUNICATIONS, AND LOCATING SYSTEM**

[76] Inventor: **Craig A. Will**, 37675 Fremont Blvd.  
No. 23, Fremont, Calif. 94536

[21] Appl. No.: **191,111**

[22] Filed: **Feb. 3, 1994**

[51] Int. Cl.<sup>6</sup> ..... **H04L 1/18**

[52] U.S. Cl. .... **371/33**

[58] Field of Search ..... 371/32, 33; 455/54.1,  
455/53.1, 89; 379/56, 57

### References Cited

#### U.S. PATENT DOCUMENTS

3,439,320	4/1969	Ward	367/191
3,696,384	10/1972	Lester	367/199
3,805,227	4/1974	Lester	367/6
3,805,265	4/1974	Lester	342/44
4,172,969	10/1979	Levine et al.	379/70
4,356,484	10/1982	Eckhardt	340/825.03
4,601,064	7/1986	Shiple	359/172
4,696,054	9/1987	Tsugei et al.	455/89
4,775,996	10/1988	Emerson et al.	379/61
4,823,123	4/1989	Siwiak	340/825.44
4,970,714	11/1990	Chen et al.	370/17
5,062,151	10/1991	Shiple	359/154
5,151,930	9/1992	Hagl	379/57
5,153,582	10/1992	Davis	340/825.44
5,265,033	11/1993	Vajk et al.	364/514
5,396,537	3/1995	Schwendeman	379/57
5,438,611	8/1995	Campana, Jr. et al.	379/58
5,479,408	12/1995	Will	370/94.1
5,493,692	2/1996	Theimer et al.	455/26.1
5,526,401	6/1996	Roach, Jr. et al.	379/59

### OTHER PUBLICATIONS

Stallings, William. *Data and Computer Communications*, Second Edition, MacMillan Publishing, 1988, pp. 107-112 and 141-144.

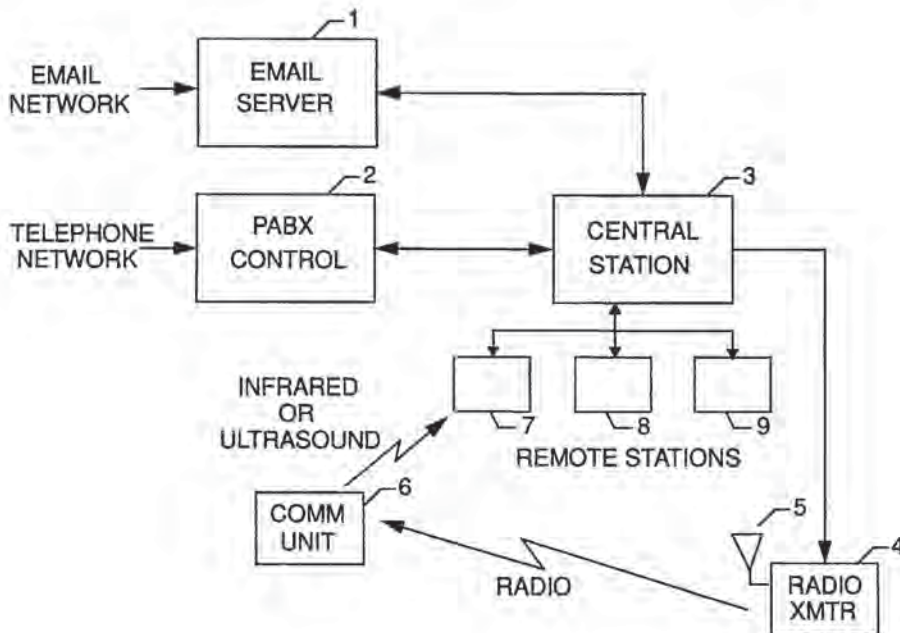
Weiser, Mark. *The Computer for the 21st Century*. pp. 94-104 Scientific American, Sep., 1991.

*Primary Examiner*—Stephen M. Baker

### [57] ABSTRACT

A method and apparatus for sending paging signals and messages to individuals within a building and accepting responses to the messages. Messages may be initiated by electronic mail, incoming telephone calls, incoming Fax messages, or other sources. Data is sent via radio to a communications unit carried by the individual and displayed visually together with possible responses. Each unit transmits its identity and responses or original messages when desired via coded infrared light (or, in an alternative embodiment, ultrasound) to one or more remote stations located in rooms or along corridors of the building. A remote station relays data to a central station via wire or optical fiber, which tracks the location of units and delivers messages. Communication units are clipped to the clothing of users and can be incorporated into a corporate employee identification badge. The hybrid radio-infrared light approach combines the broad, reliable characteristics of radio communication with the ability of infrared light to allow each unit to be located. This allows highly reliable delivery of messages via an acknowledgement and retransmission protocol, two-way communication with the individual, and capabilities (such as those for transferring incoming telephone calls) that require the location of the individual to be known.

25 Claims, 26 Drawing Sheets





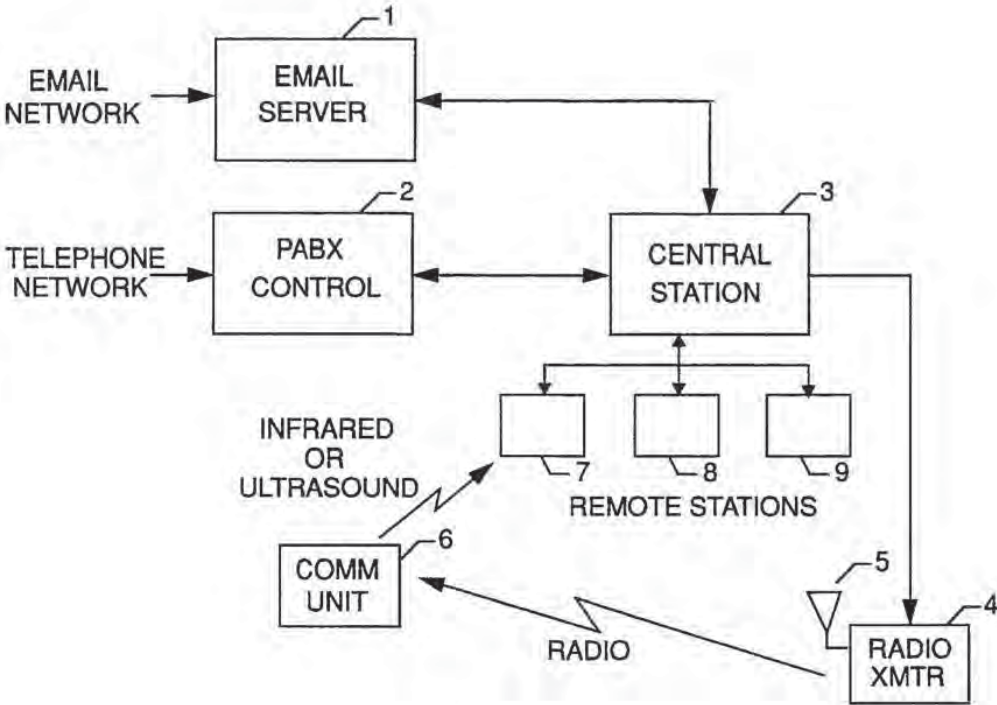


FIG. 1

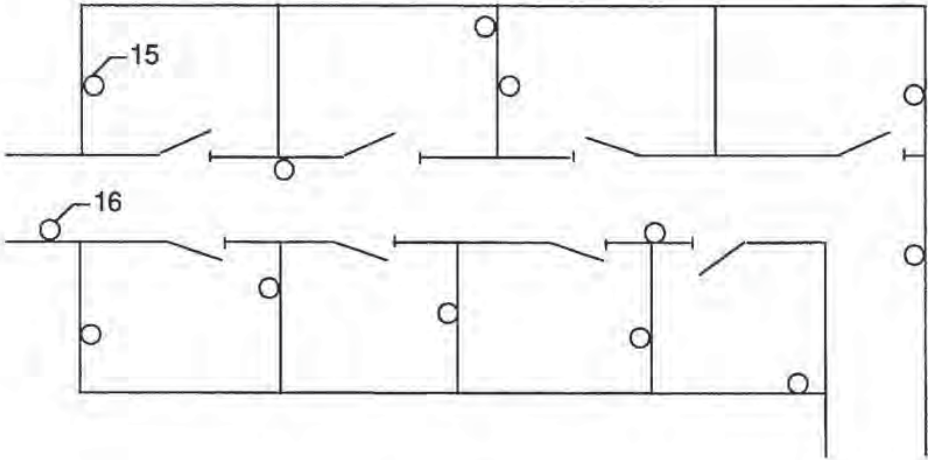


FIG. 2

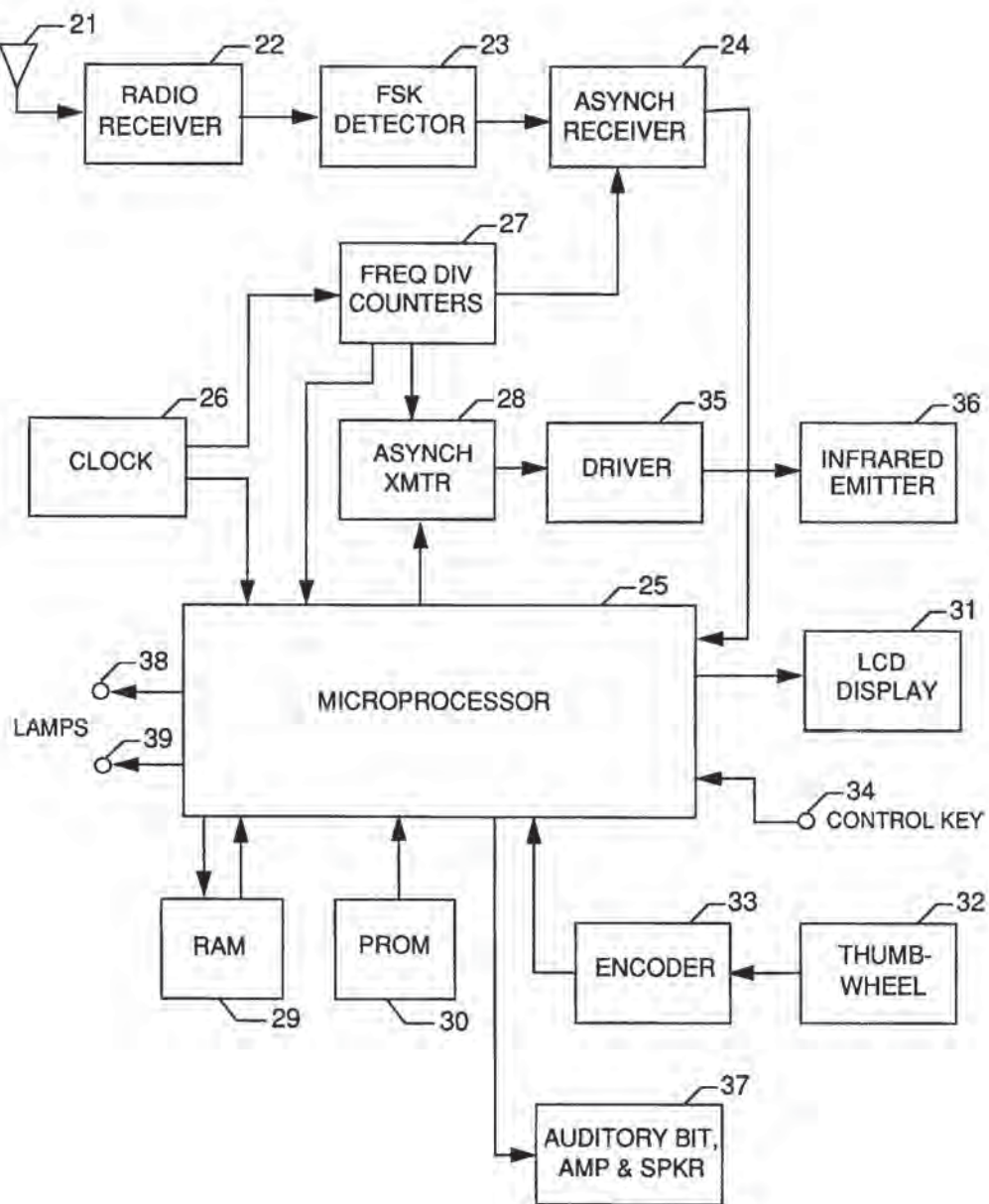


FIG. 3

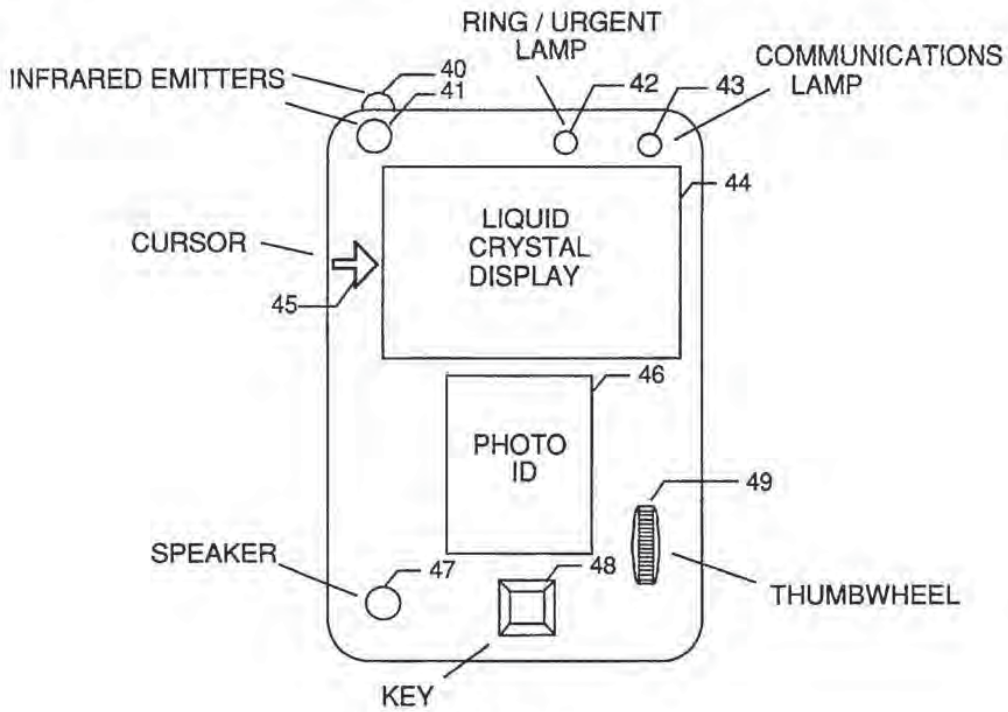


FIG. 4

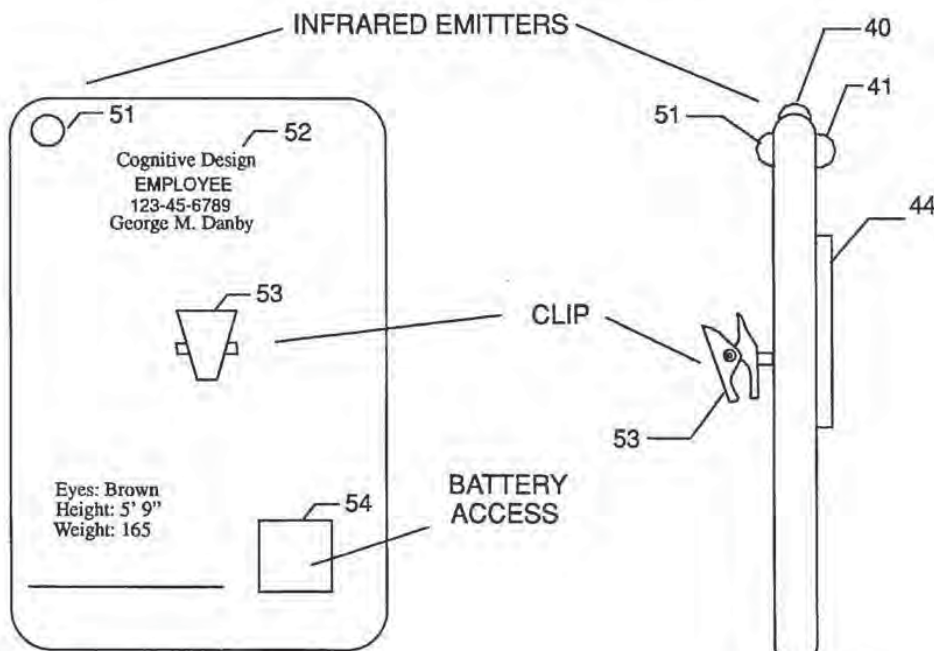
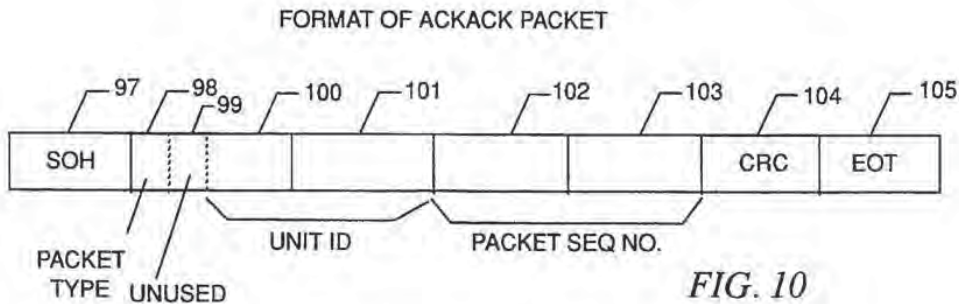
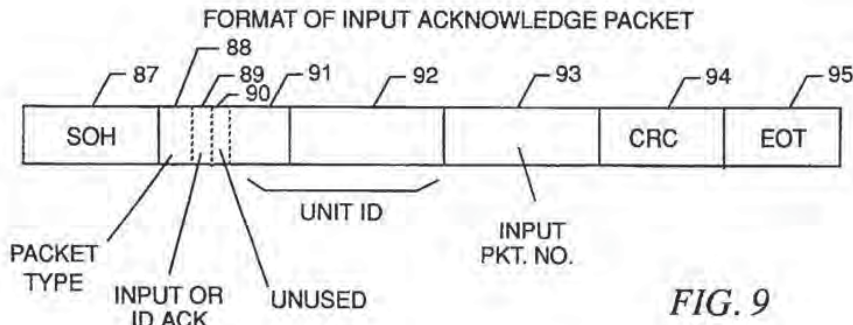
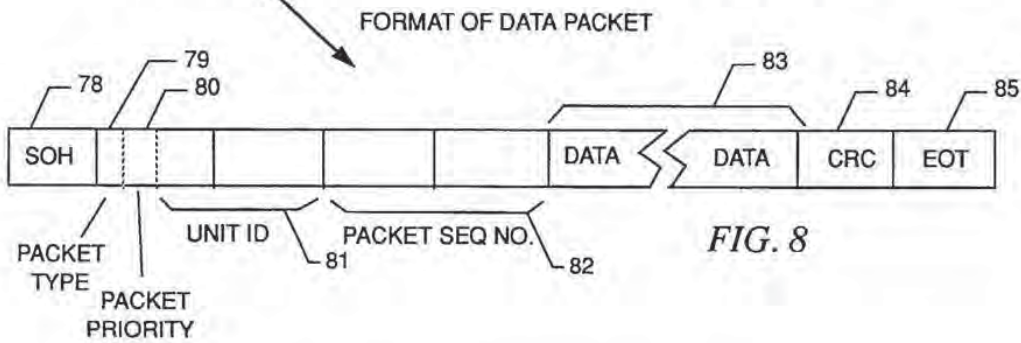
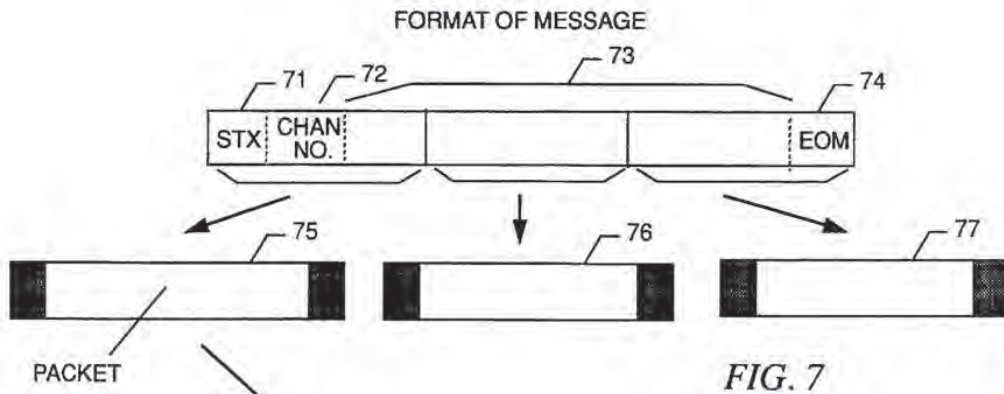


FIG. 5

FIG. 6



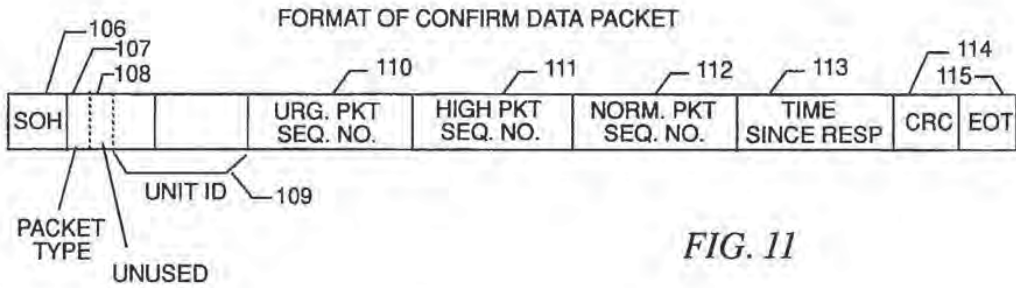


FIG. 11

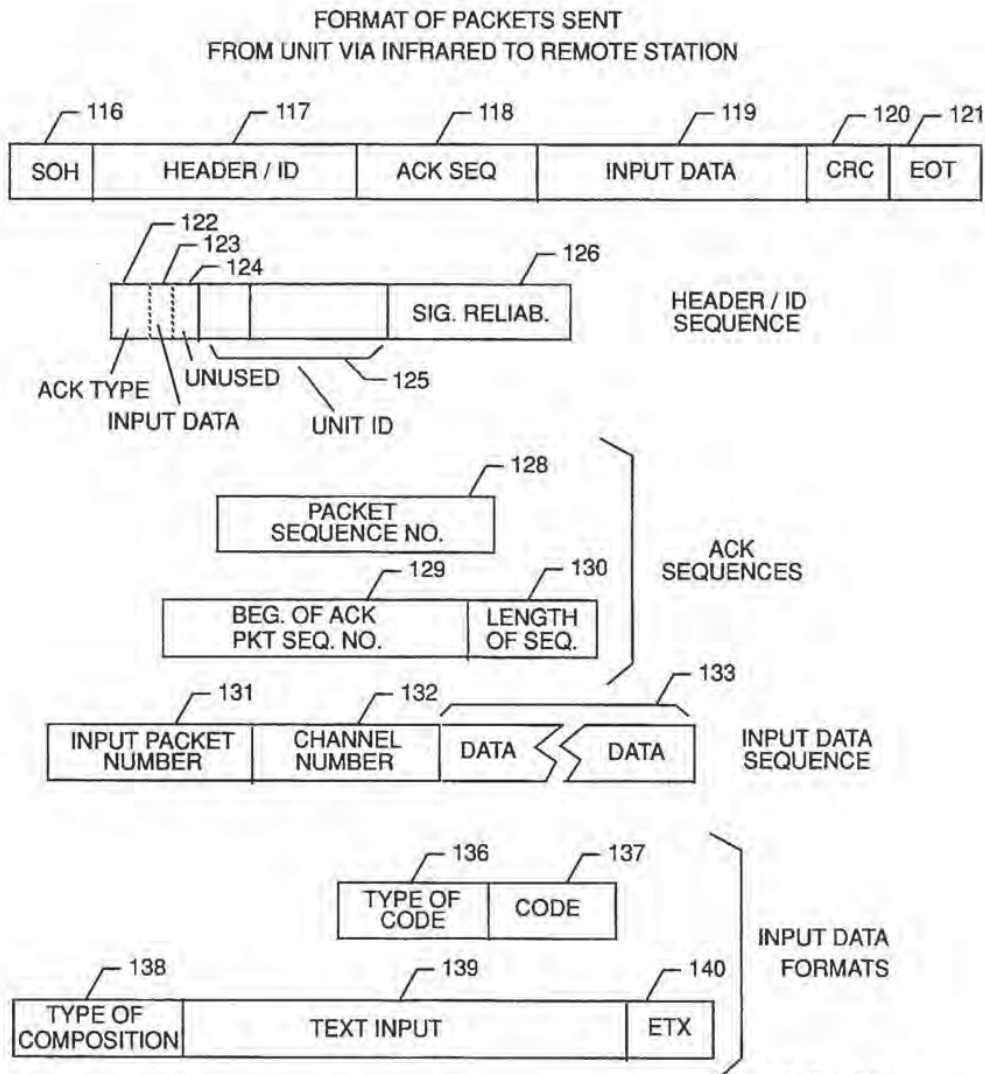


FIG. 12

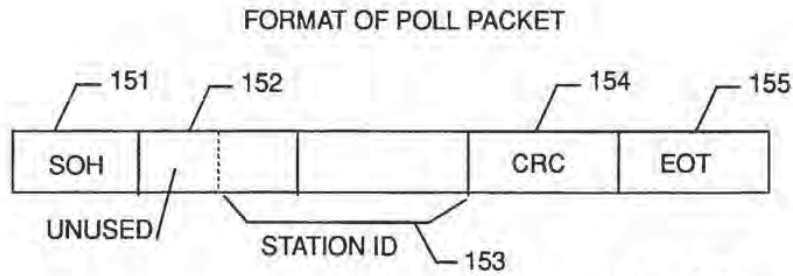


FIG. 13

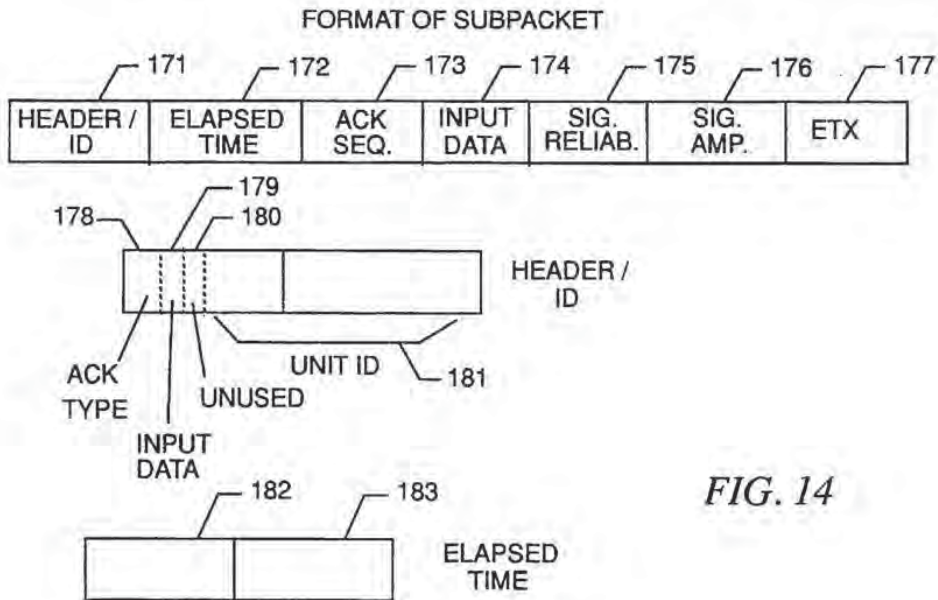
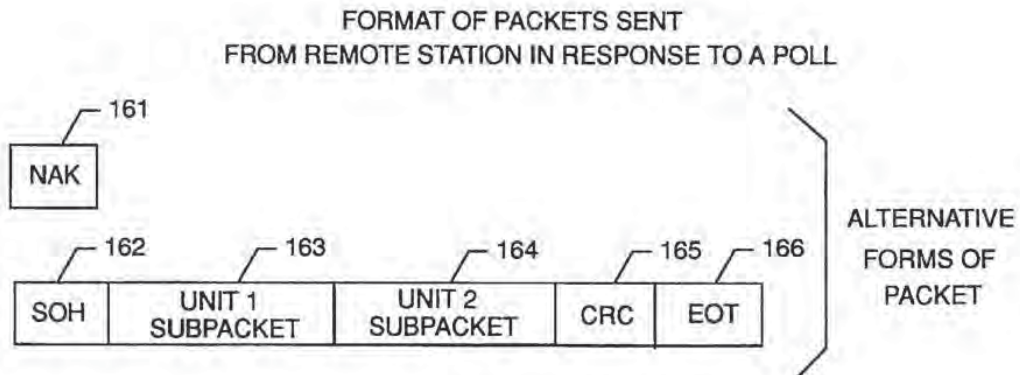


FIG. 14

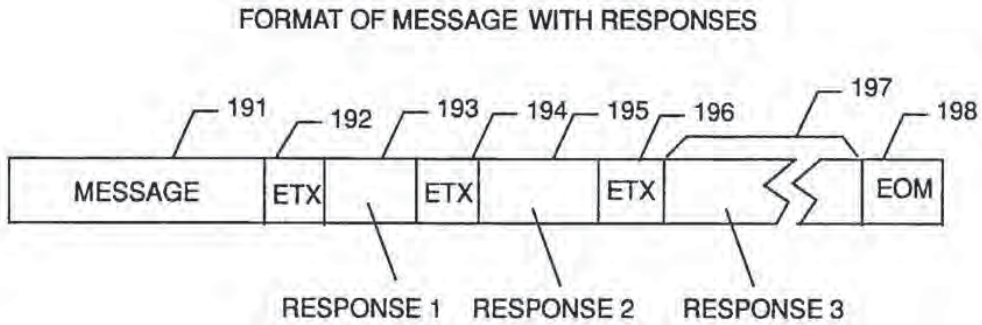


FIG. 15

FORMAT OF MESSAGE DEFINING PREPROGRAMMED  
RESPONSES, MESSAGES, AND EMAIL ADDRESSES

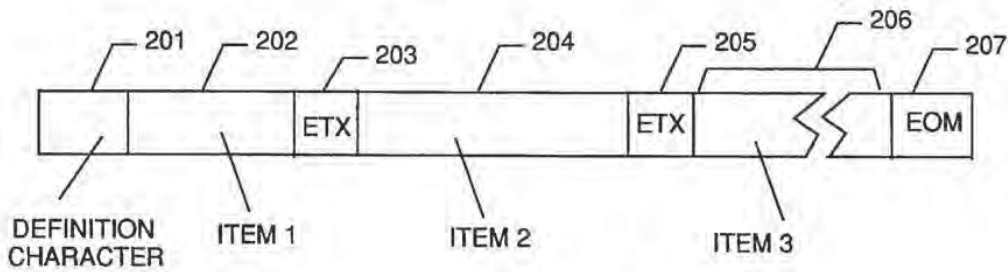


FIG. 16

SOFTWARE ARCHITECTURE FOR CENTRAL STATION

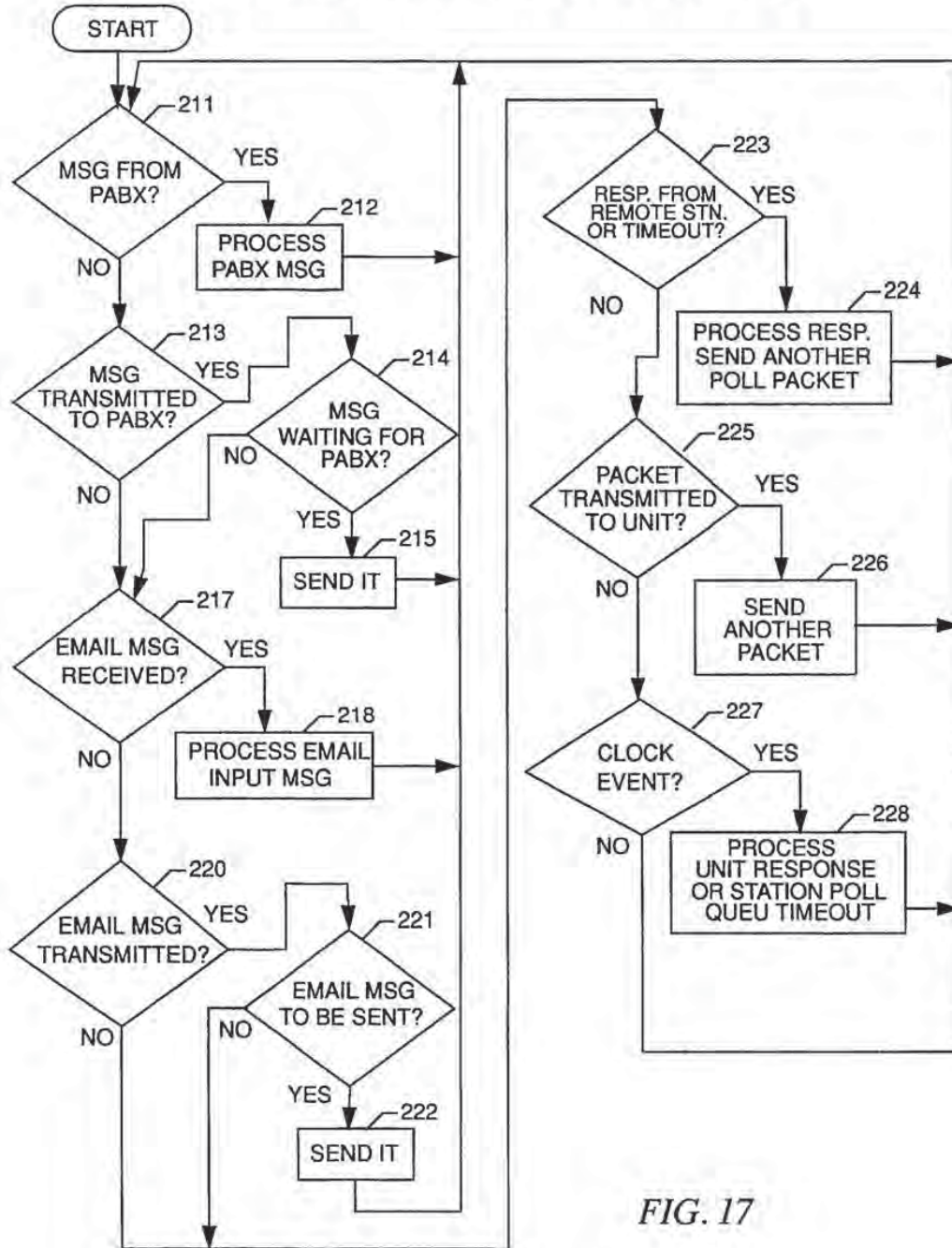


FIG. 17



MODULE TO PROCESS RECEIVED EMAIL MESSAGE

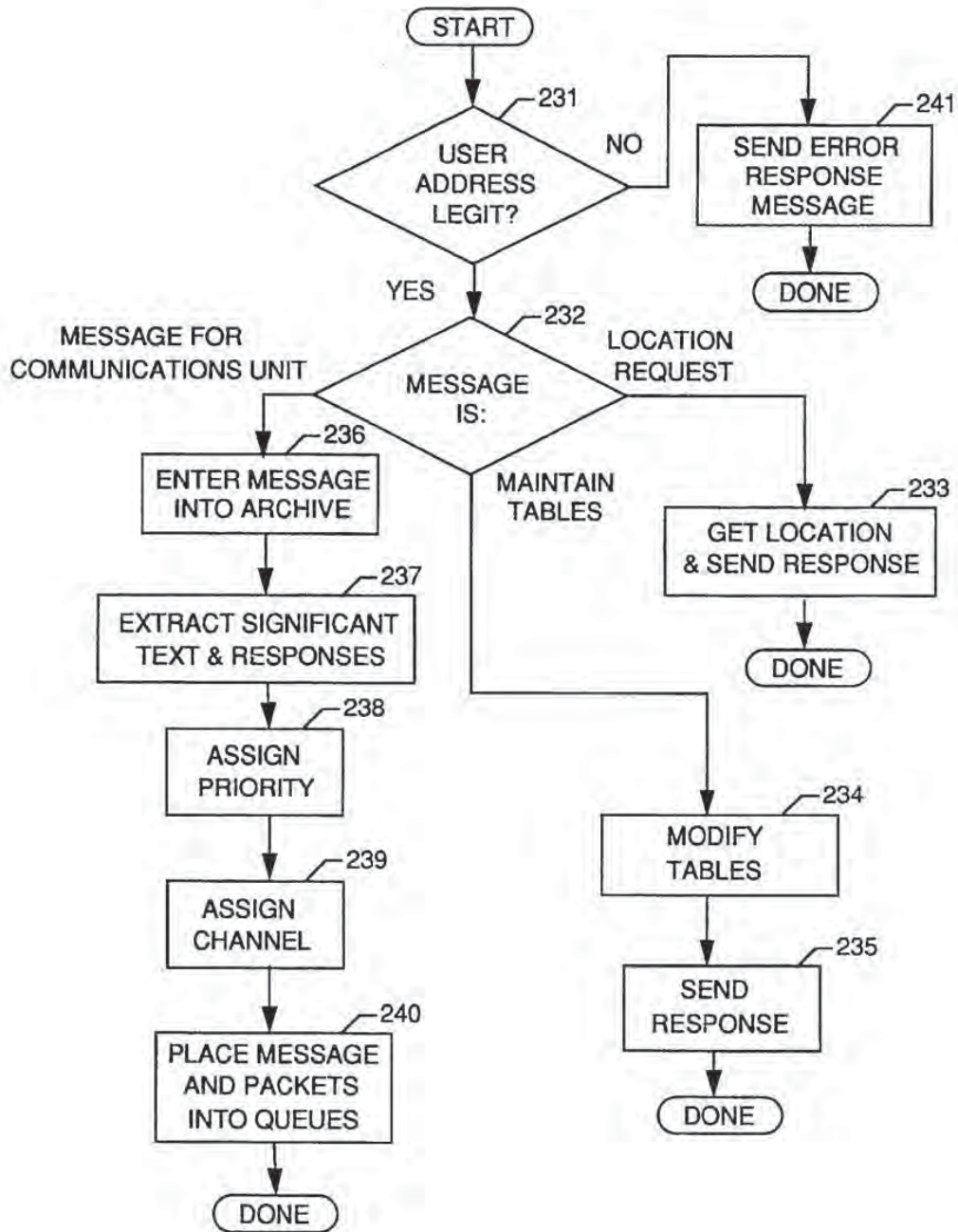


FIG. 18

MODULE TO PROCESS RESPONSE RECEIVED FROM STATION

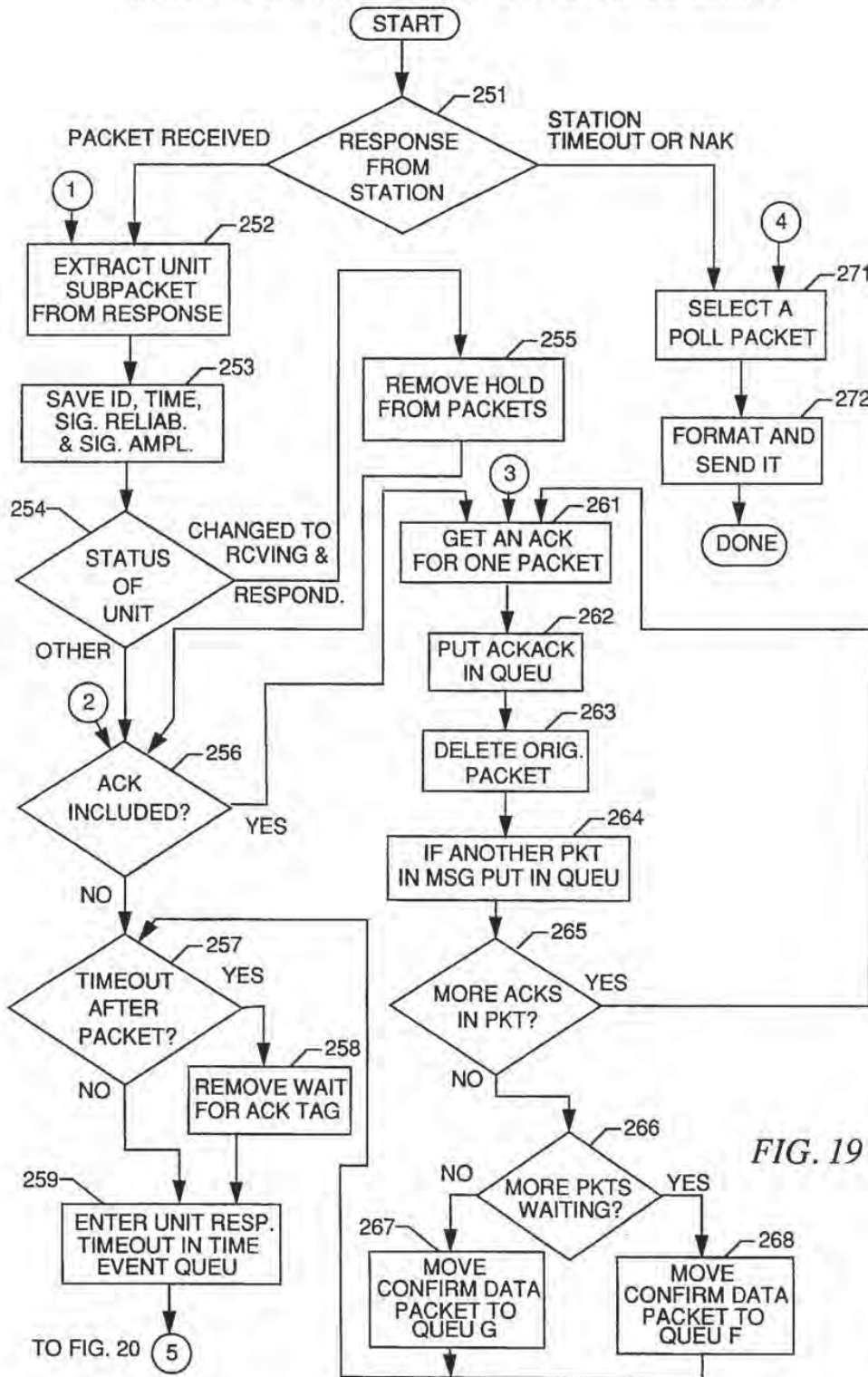


FIG. 19

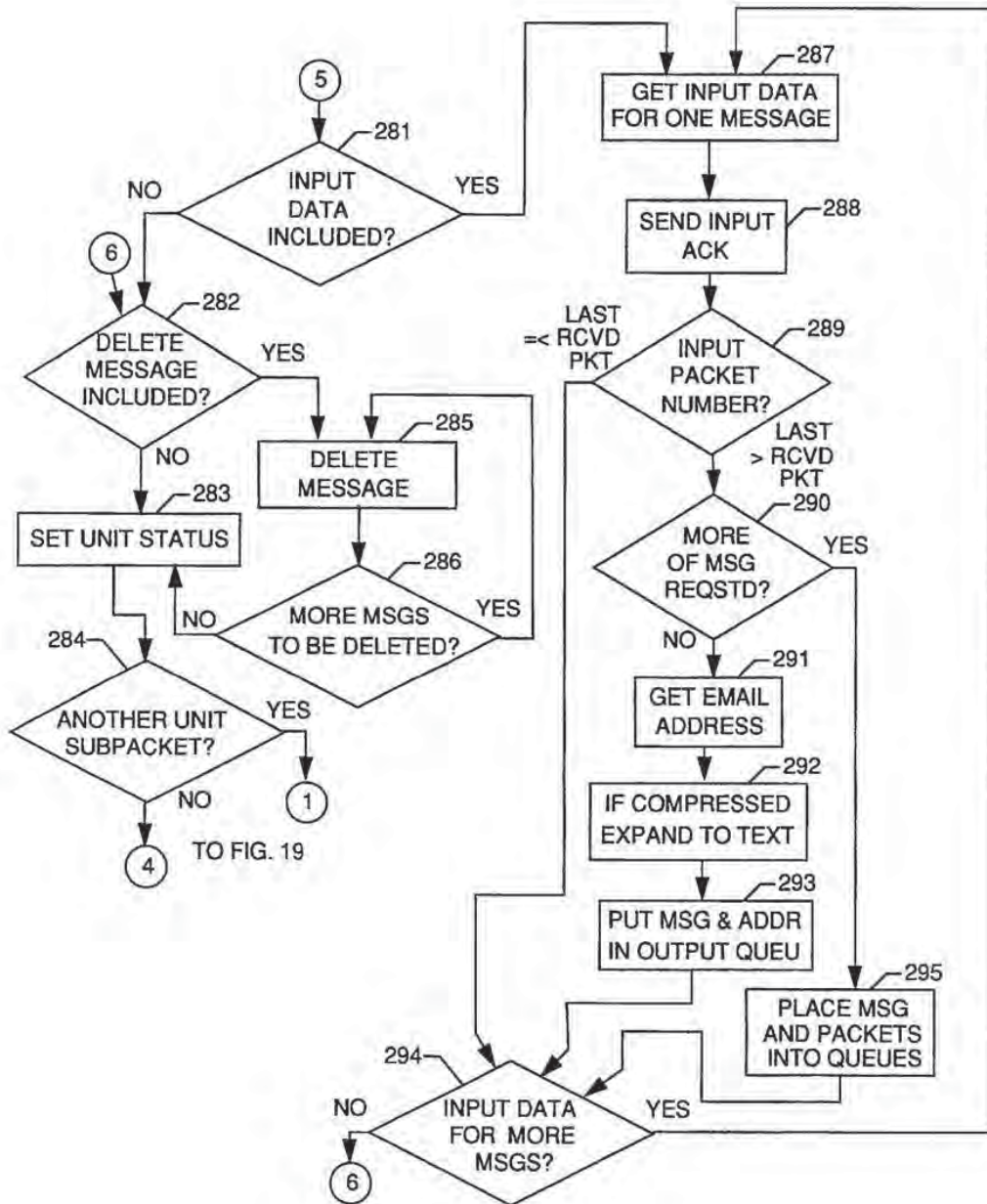


FIG. 20

MODULE INITIATED UPON COMPLETION  
OF RADIO PACKET TRANSMISSION

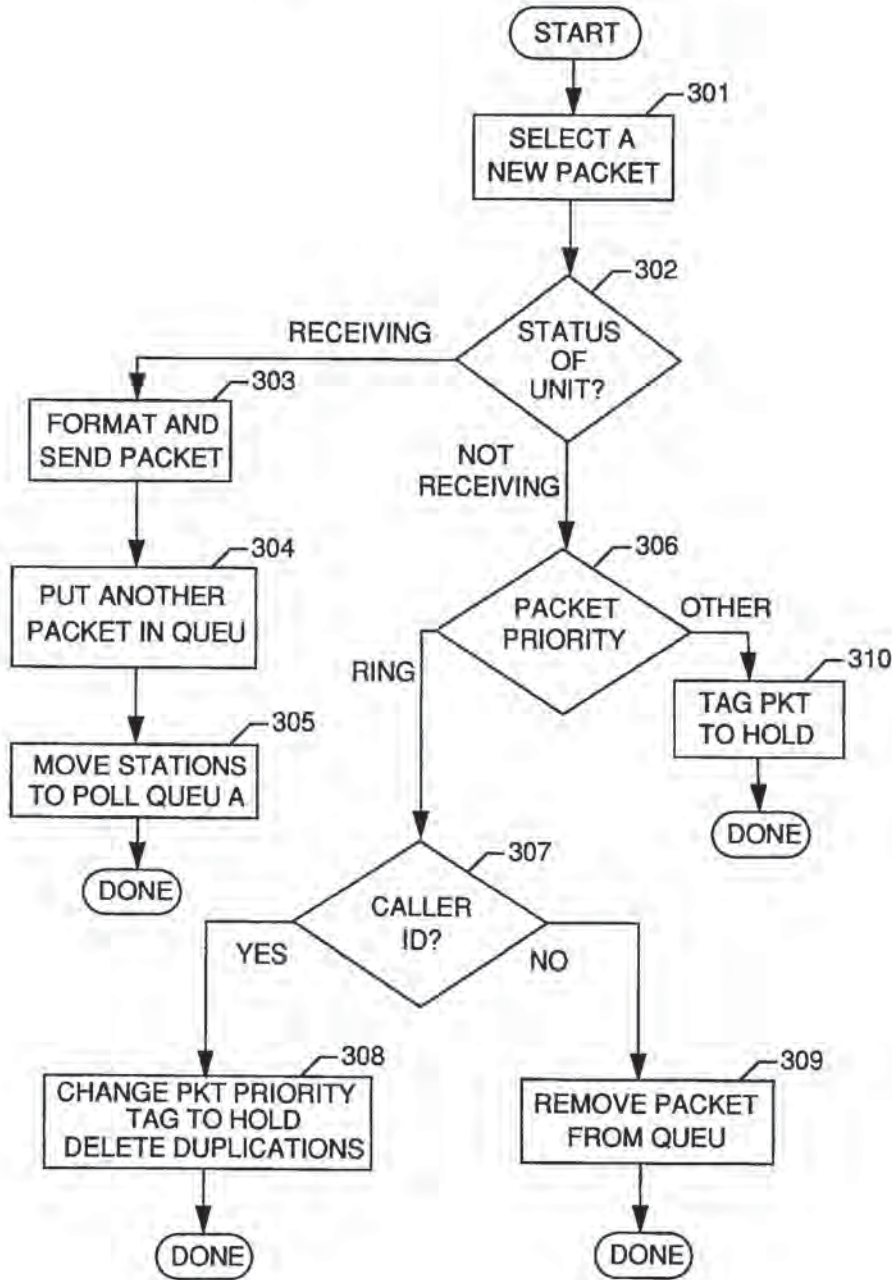


FIG. 21

CENTRAL STATION  
CLOCK INTERRUPT MODULE

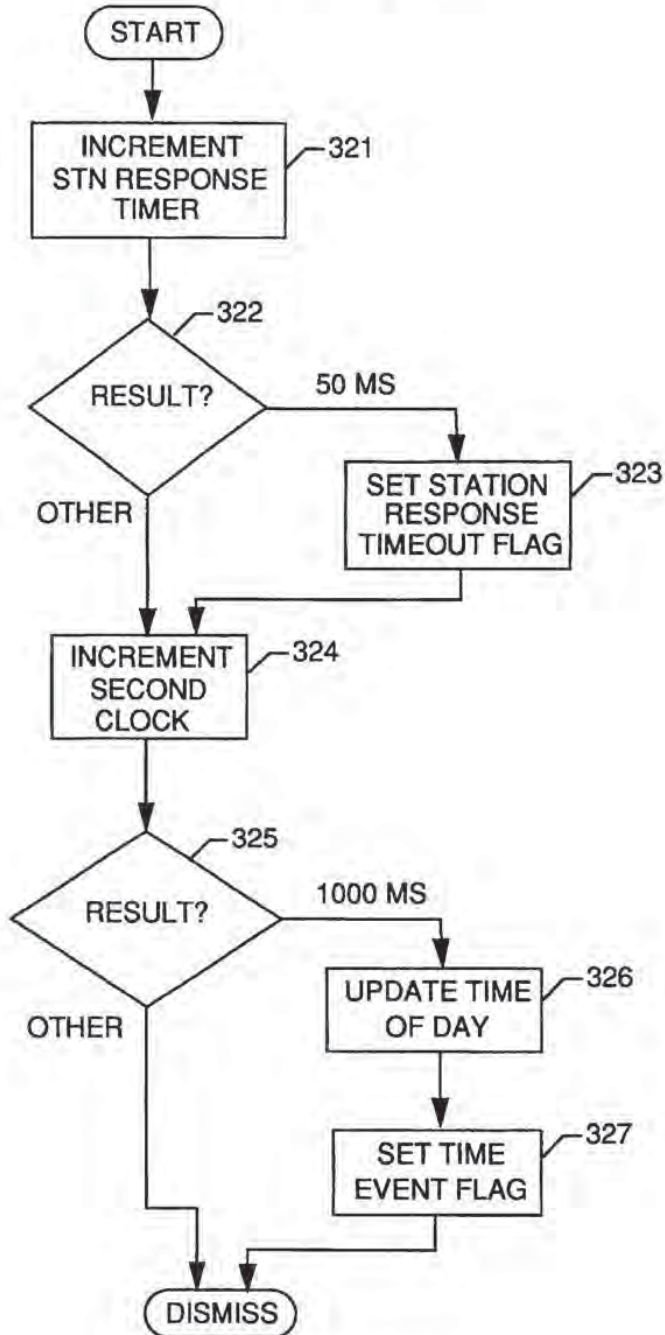


FIG. 22

CENTRAL STATION DATA STRUCTURES

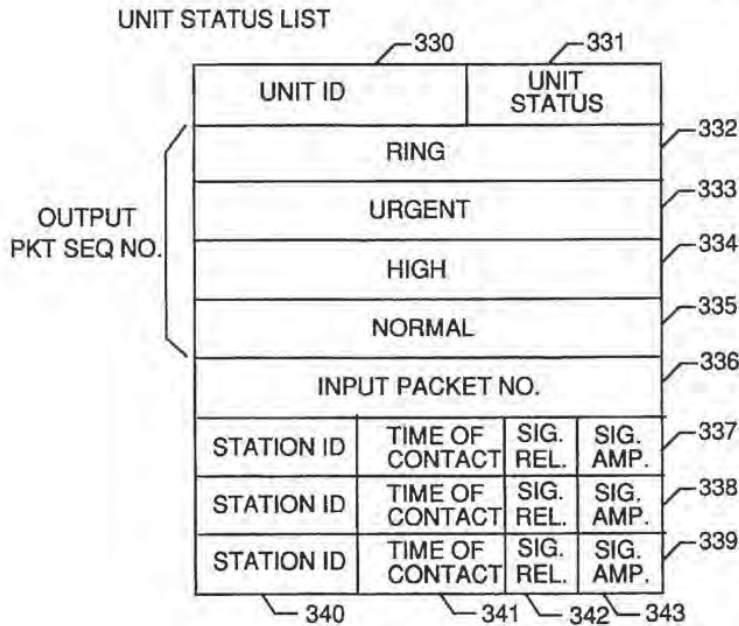


FIG. 23

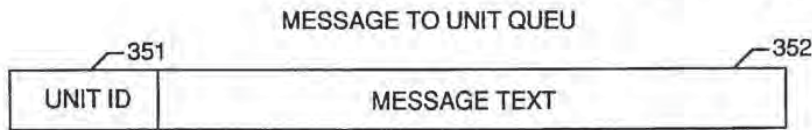


FIG. 24

PACKET TO UNIT QUEUES (A TO G)

	361	362	363	364	365	366
QUEU A	UNIT ID	HOLD BIT	WAIT FOR ACK BIT	NO. OF TR ATTMPTD	POINTER TO TEXT	SEQ NO. IF SENT
QUEU B	UNIT ID	HOLD BIT	WAIT FOR ACK BIT	NO. OF TR ATTMPTD	POINTER TO TEXT	SEQ NO. IF SENT
QUEU C	UNIT ID	HOLD BIT	WAIT FOR ACK BIT	NO. OF TR ATTMPTD	POINTER TO TEXT	SEQ NO. IF SENT
QUEU D	UNIT ID	HOLD BIT	WAIT FOR ACK BIT	NO. OF TR ATTMPTD	POINTER TO TEXT	SEQ NO. IF SENT
QUEU E	UNIT ID	HOLD BIT	WAIT FOR ACK BIT	NO. OF TR ATTMPTD	POINTER TO TEXT	SEQ NO. IF SENT
QUEU F	UNIT ID	HOLD BIT	WAIT FOR ACK BIT	NO. OF TR ATTMPTD	POINTER TO TEXT	SEQ NO. IF SENT
QUEU G	UNIT ID	HOLD BIT	WAIT FOR ACK BIT	NO. OF TR ATTMPTD	POINTER TO TEXT	SEQ NO. IF SENT

FIG. 25

CENTRAL STATION DATA STRUCTURES  
(CONTINUED)

POLL QUEUES (A to C)

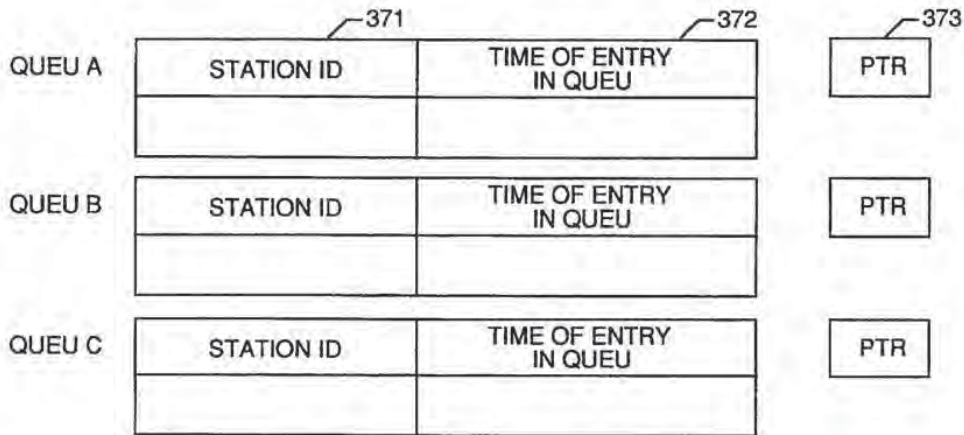
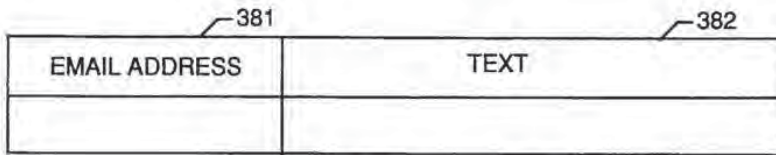
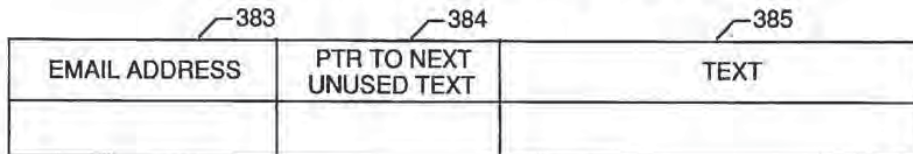


FIG. 26

EMAIL INCOMING MESSAGE QUEUE



EMAIL INCOMING MESSAGE ARCHIVE



EMAIL OUTGOING MESSAGE QUEUE

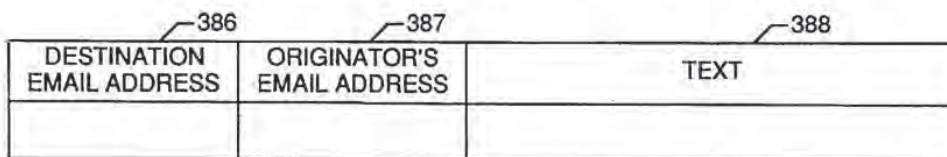


FIG. 27

CENTRAL STATION DATA STRUCTURES  
(CONTINUED)

EMAIL ADDRESS TO UNIT ID MAP

EMAIL ADDRESS	UNIT ID

UNIT ID TO EMAIL ADDRESS MAP

UNIT ID	EMAIL ADDRESS

CHANNEL TO EMAIL ADDRESS MAP

CHANNEL	ASSIGNED BIT	EMAIL ADDRESS	PTR TO INCOMING EMAIL MESSAGE ARCHIVE

FIG. 28

INPUT DATA FROM UNIT QUEUE

UNIT ID	CHAN. NO.	INPUT PKT NO.	TEXT

FIG. 29



CENTRAL STATION DATA STRUCTURES  
(CONTINUED)

PREPROGRAMMED RESPONSE LIST

421	422
CODE	RESPONSE

PREPROGRAMMED MESSAGE LIST

423	424
CODE	MESSAGE

PREPROGRAMMED EMAIL ADDRESS LIST

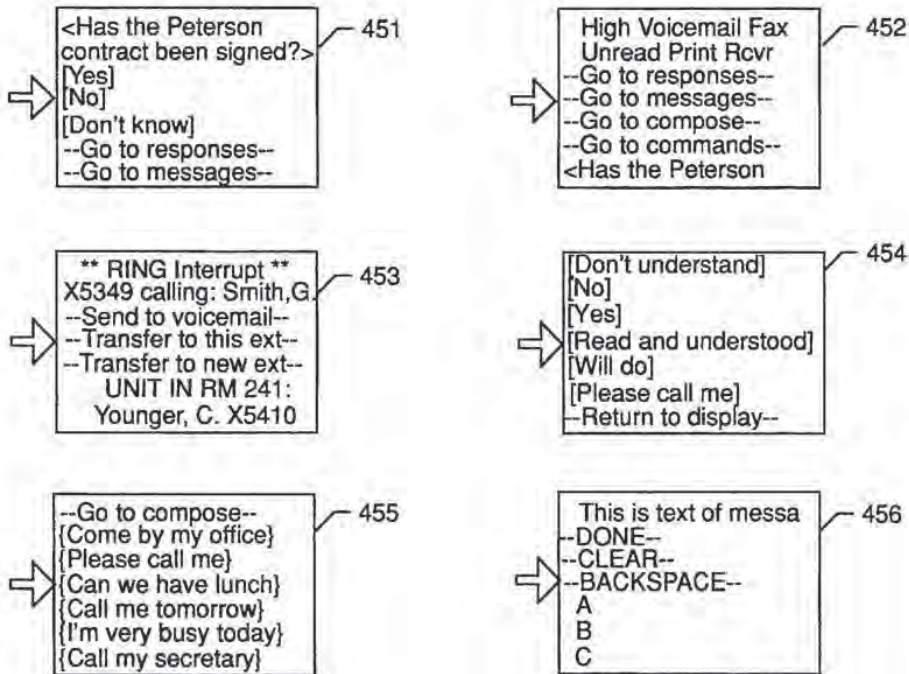
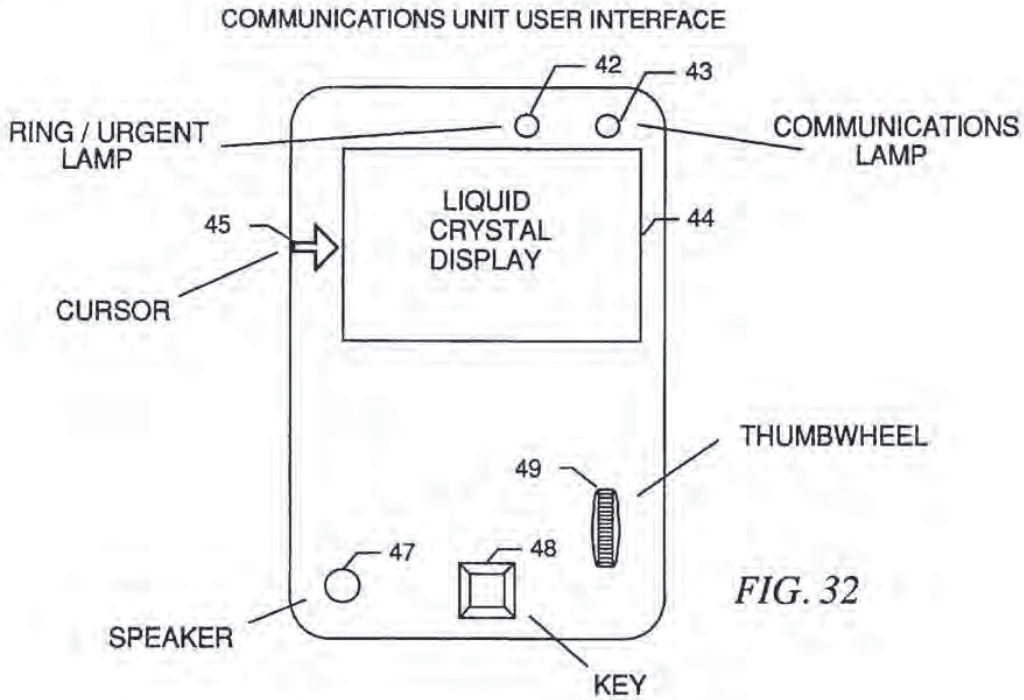
425	426
CODE	

FIG. 30

TIME EVENT QUEU

427	428	429	430
TIME OF FUTURE EVENT	TYPE	QUEU	UNIT/ STATION ID

FIG. 31



SOFTWARE ARCHITECTURE  
FOR COMMUNICATIONS UNIT

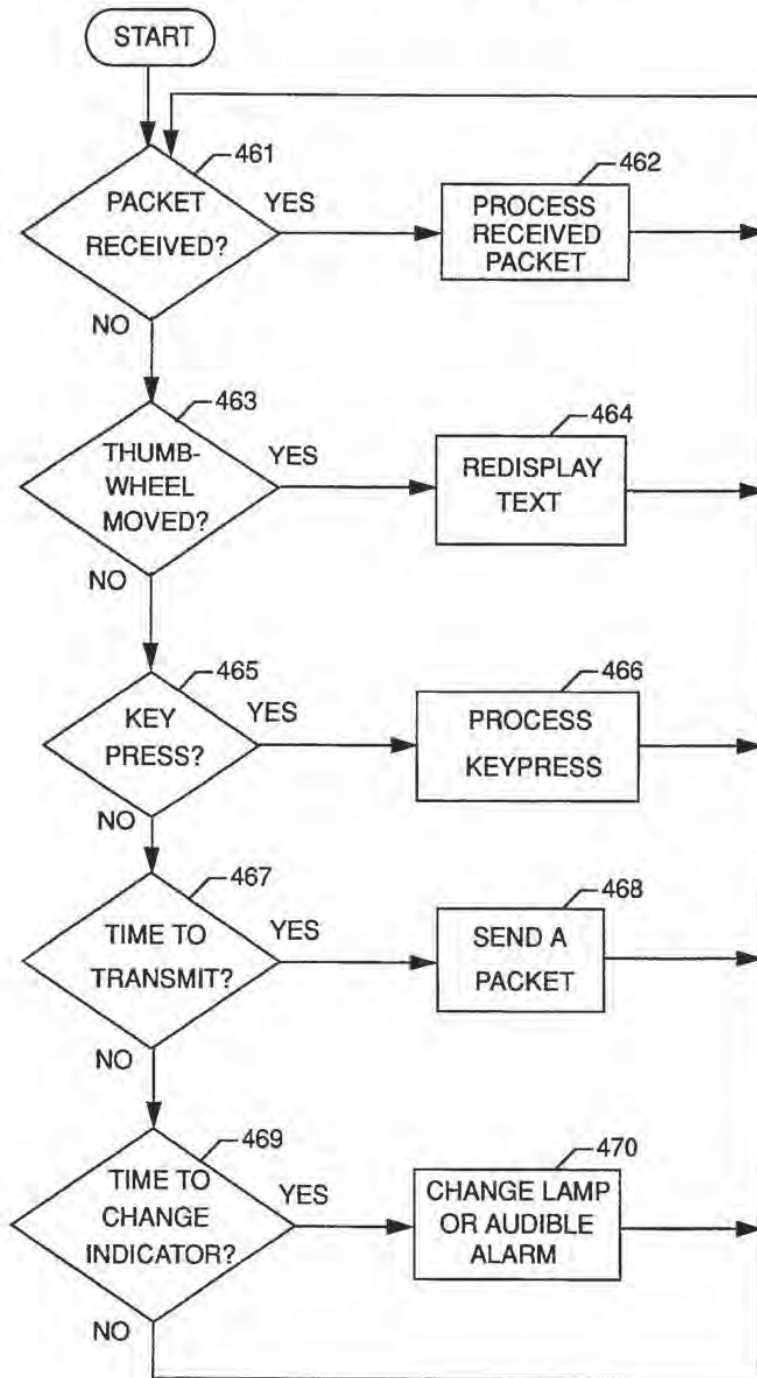


FIG. 34

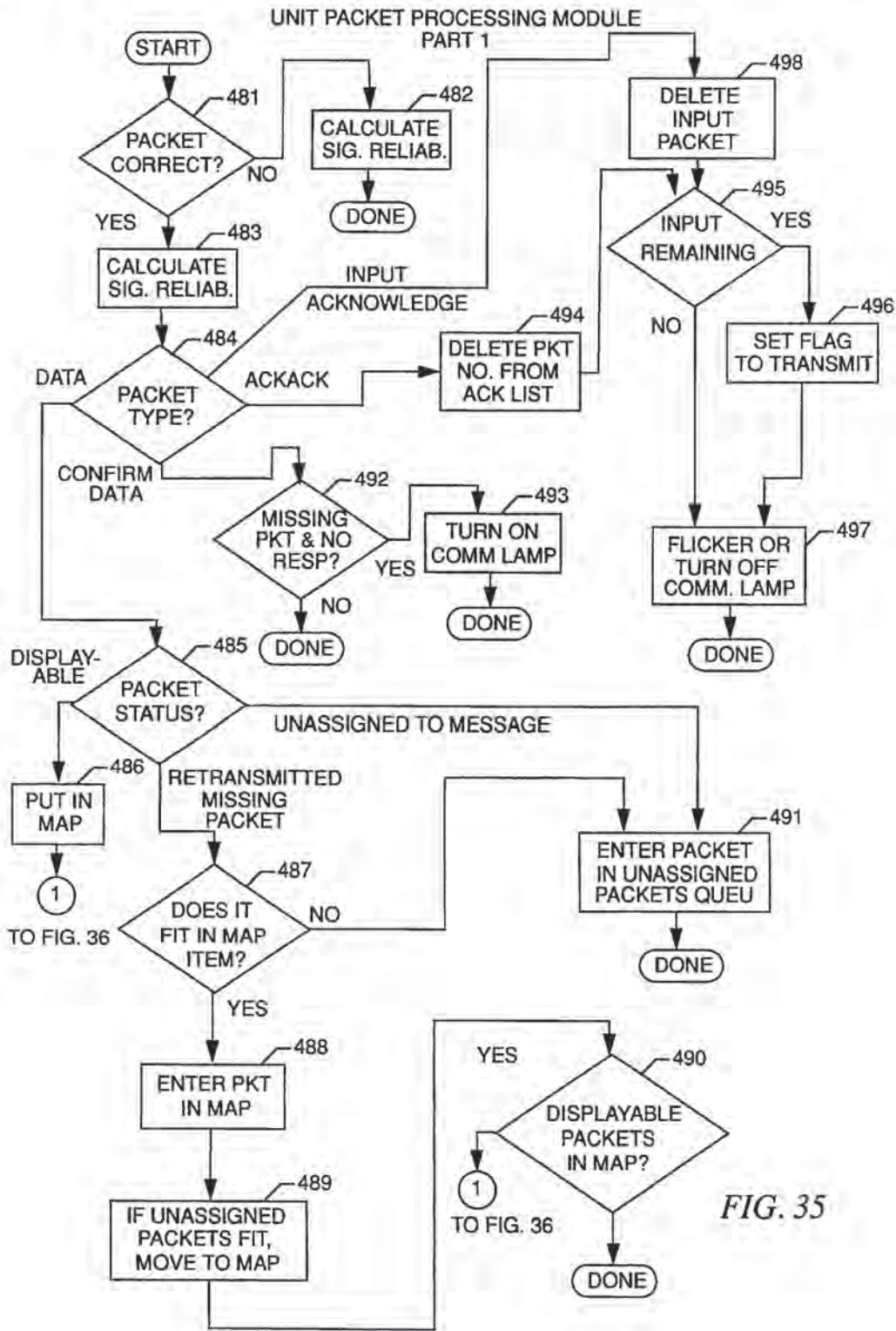


FIG. 35

UNIT PACKET PROCESSING MODULE  
PART 2

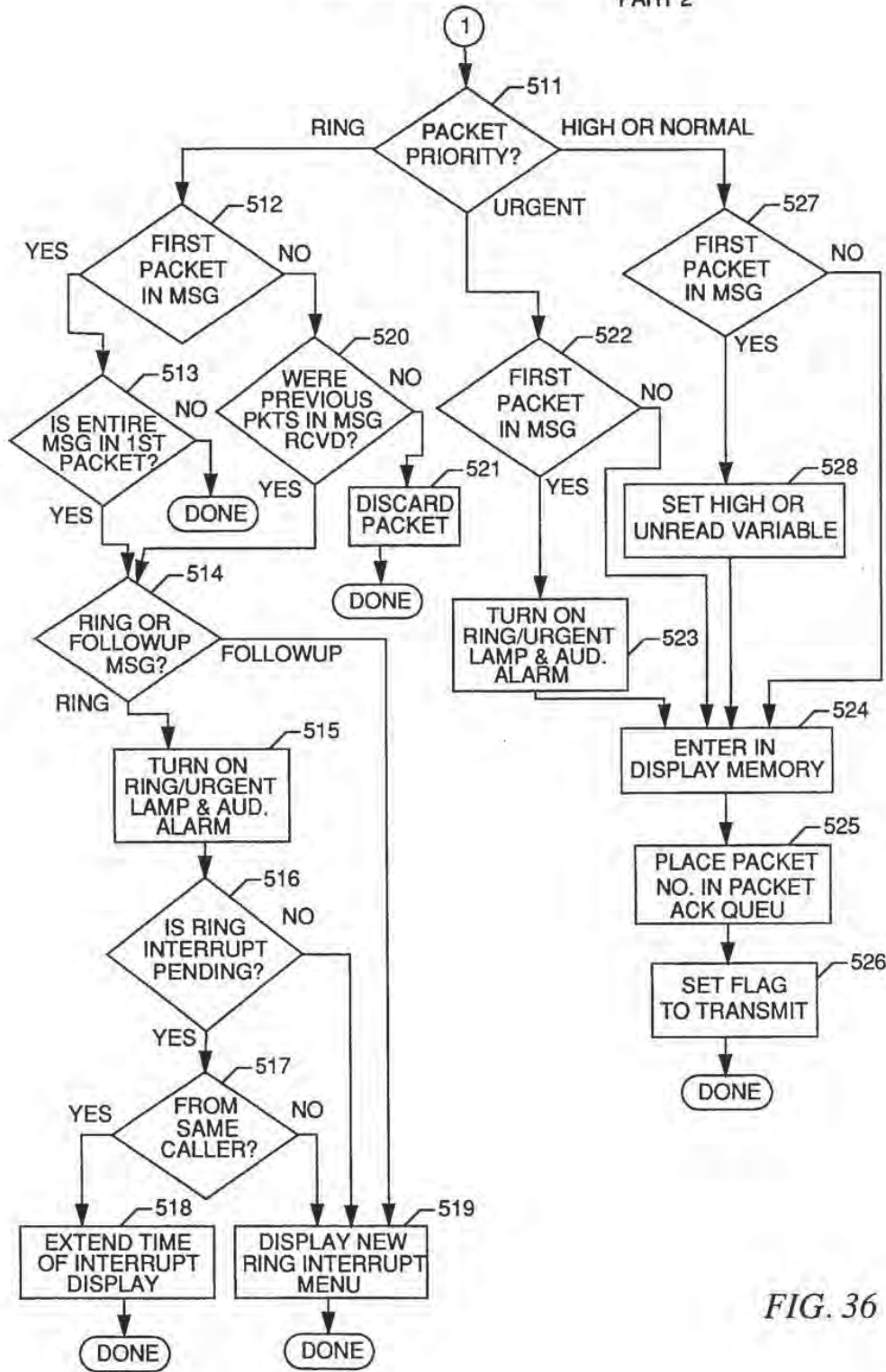


FIG. 36

CLOCK INTERRUPT SOFTWARE  
FOR COMMUNICATIONS UNIT  
PART 1

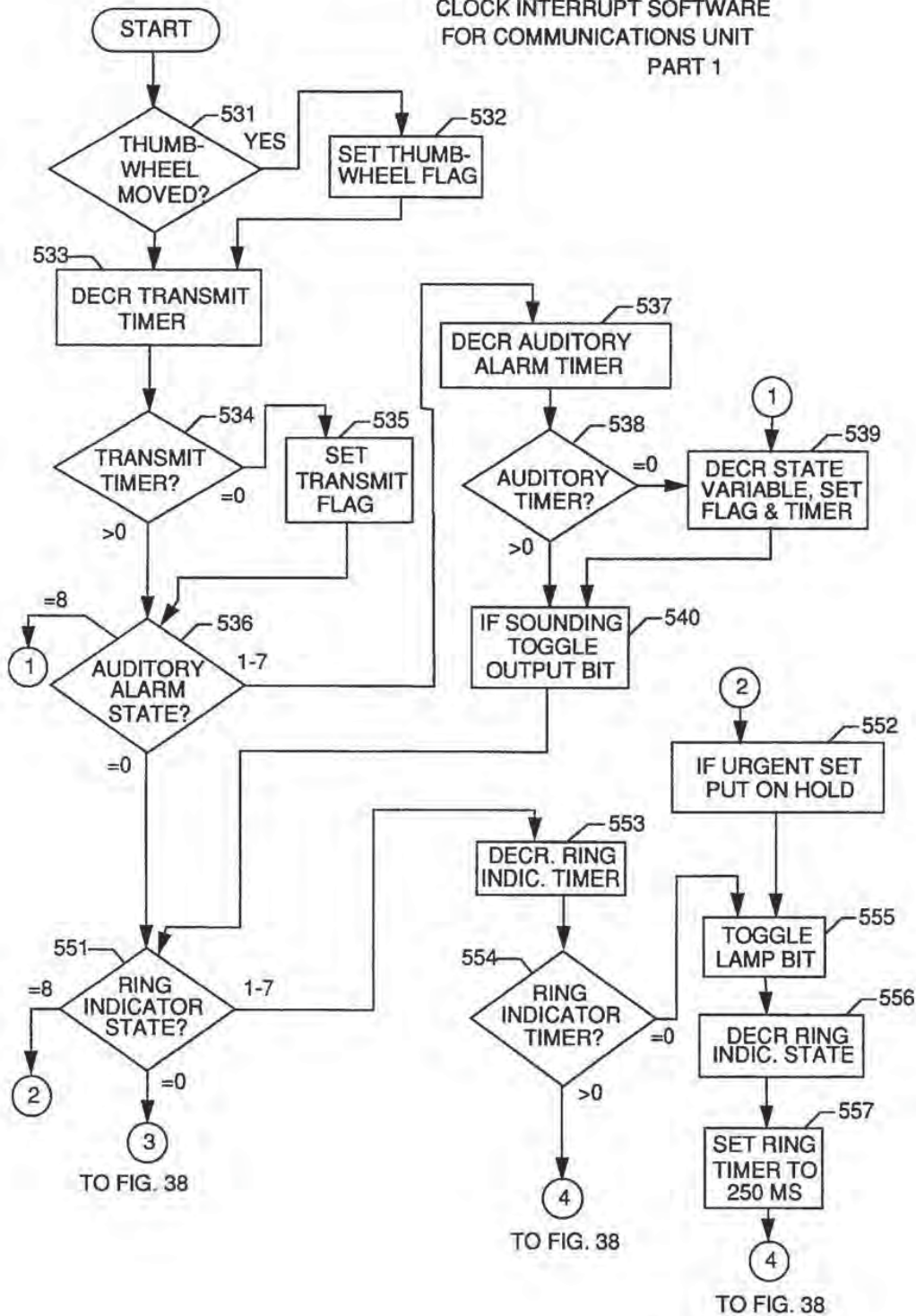


FIG. 37

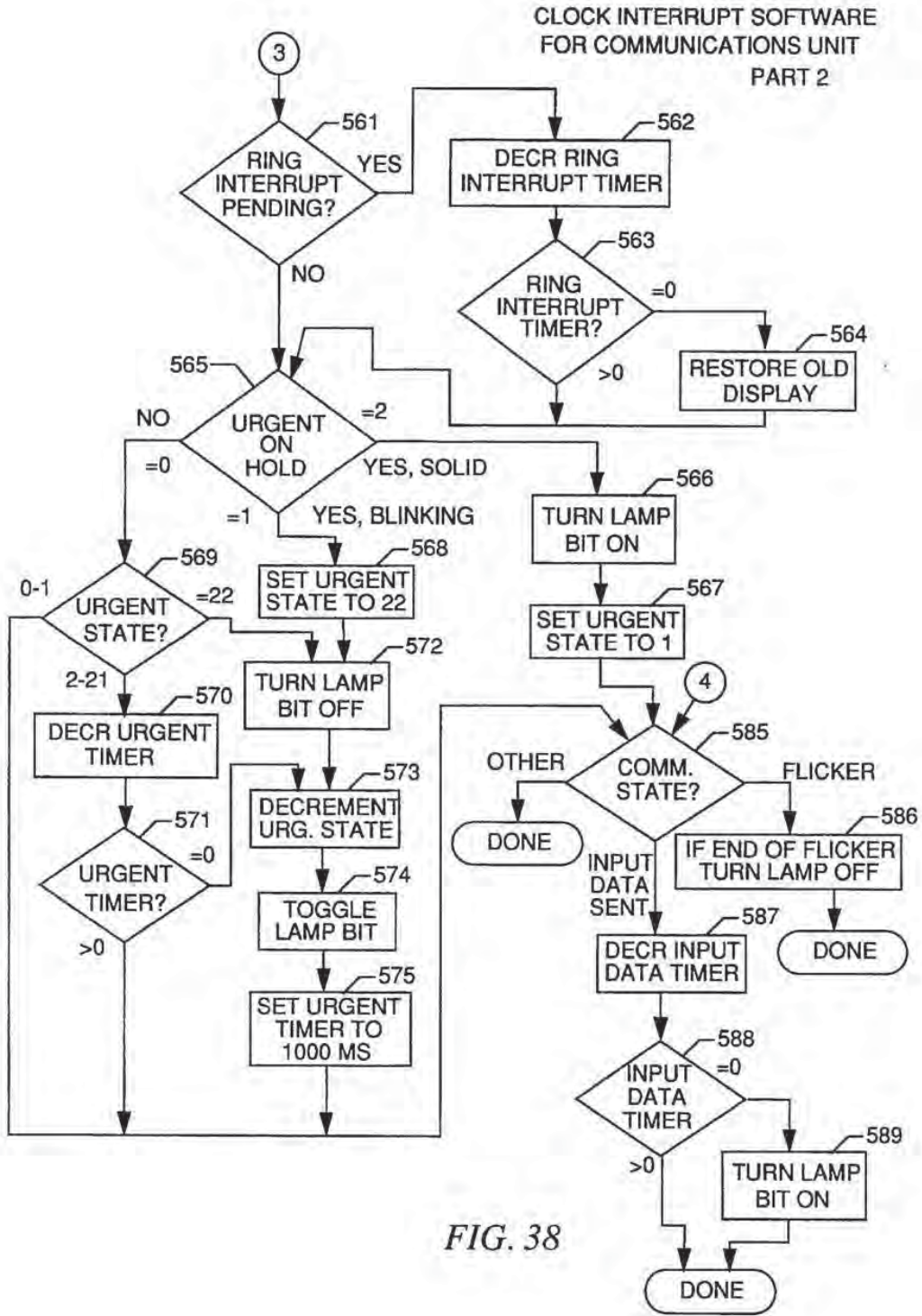
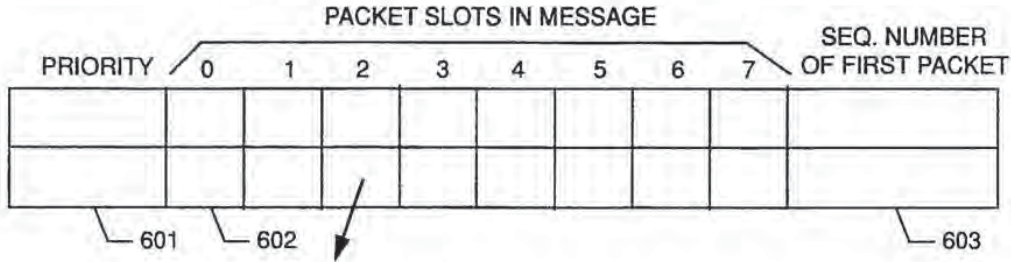


FIG. 38

COMMUNICATIONS UNIT DATA STRUCTURES  
INCOMPLETE MESSAGE PACKET MAP



EACH PACKET SLOT  
CONSISTS OF:

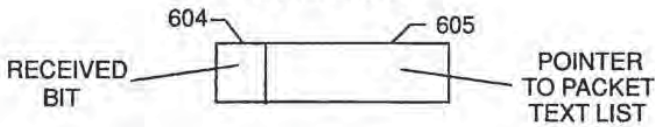


FIG. 39

PACKETS UNASSIGNED TO MESSAGES LIST

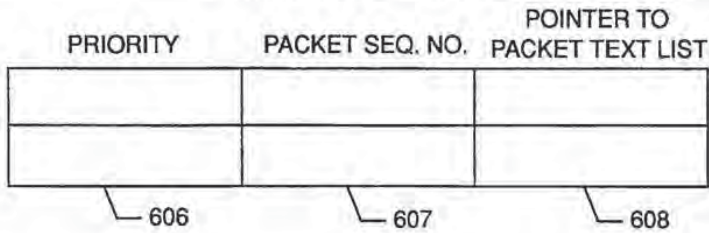


FIG. 40

PACKET TEXT LIST

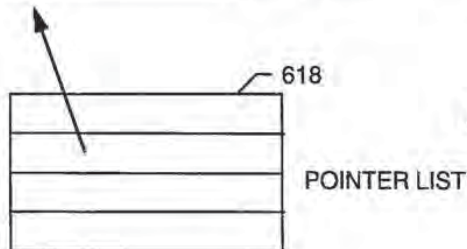
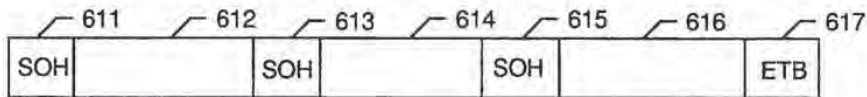


FIG. 41



COMMUNICATIONS UNIT DATA STRUCTURES (CONTINUED)

DISPLAY MEMORY STRUCTURES

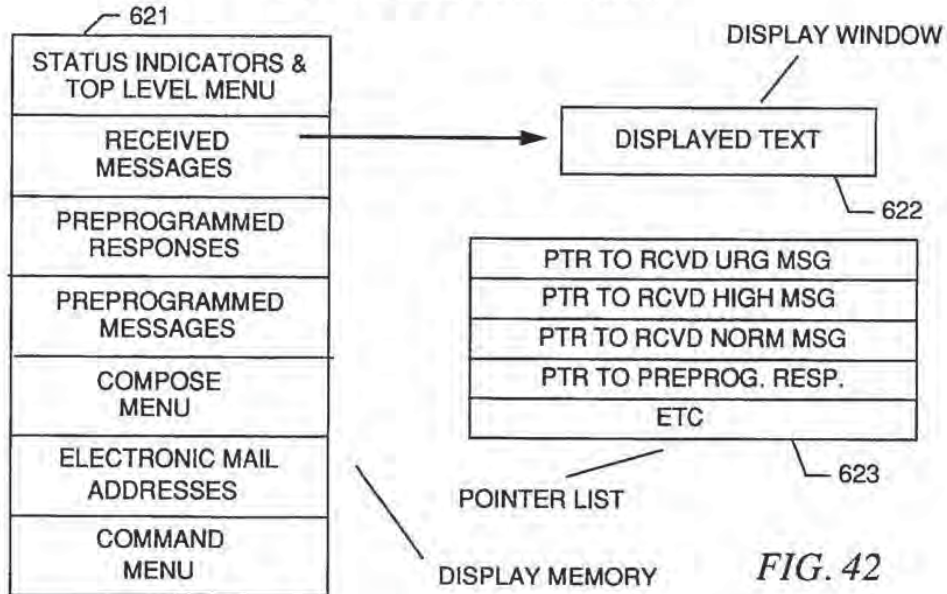
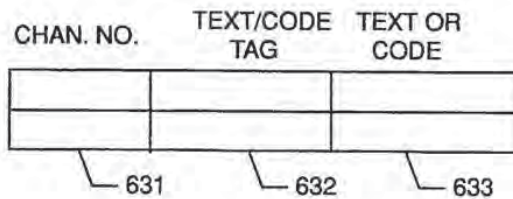
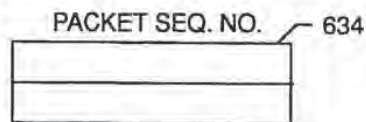


FIG. 42

INPUT DATA QUEU



PACKET ACKNOWLEDGEMENT QUEU



UNIT TRANSMISSION BUFFER

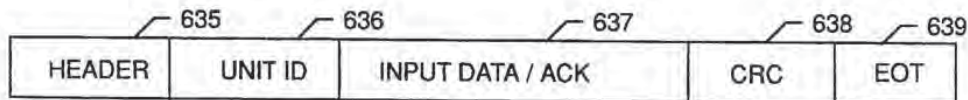


FIG. 43

REMOTE STATION SOFTWARE

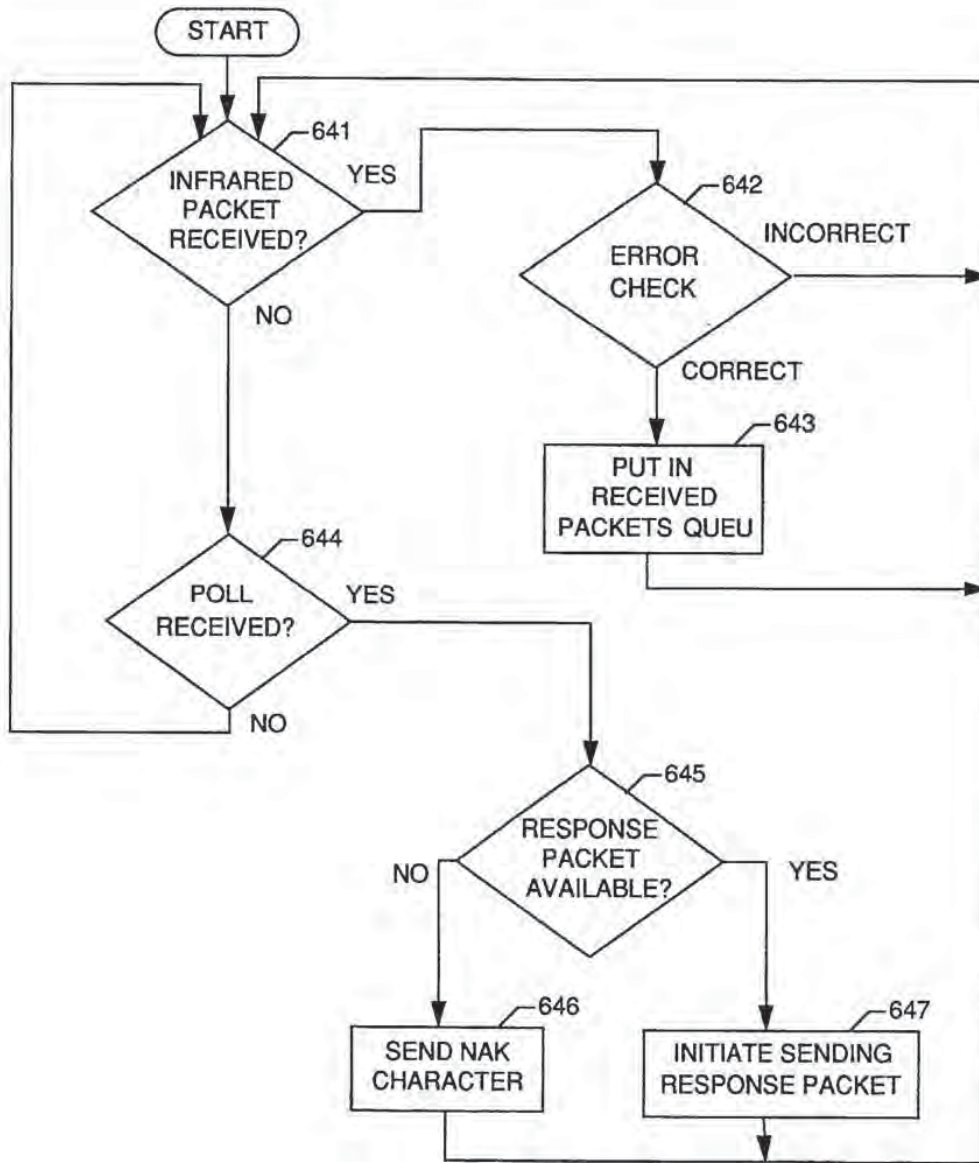


FIG. 44

**PERSONAL PAGING, COMMUNICATIONS,  
AND LOCATING SYSTEM**

**CROSS-REFERENCE TO RELATED  
APPLICATIONS**

This application relates to a copending application submitted by Craig A. Will entitled "Control of Miniature Personal Digital Assistant Using Menu and Thumbwheel," Ser. No. 08/423,690, filed Apr. 18, 1995. The application also relates to a copending application submitted by Craig A. Will entitled "Wireless Personal Paging, Communications, and Locating System", Ser. No. 08/200,065, filed Feb. 22, 1994, now U.S. Pat. No. 5,479,408, issued Dec. 26, 1995.

**FIELD OF THE INVENTION**

This invention relates generally to electronic communication systems for sending signals selectively to portable receivers that provide an indication or alarm to specific individuals that is humanly perceptible, and further to systems that indicate the location of individuals. It relates to the transmission of message data encoded as digital pulses modulating a radio wave to portable receivers, and also relates to the transmission of message data, identification, and location information using digital pulses optically, particularly by infrared light, and acoustically, particularly by ultrasound. The invention further relates to the indication of incoming calls from a telephone PBX system and the forwarding and transfer of such calls.

More specifically, the invention relates to a system for communicating with individuals in a building using digitally encoded radio in one direction and either infrared light or ultrasound in the other, with users receiving paging indications and messages and being able to acknowledge and respond to messages and to originate messages, with the system also tracking the location of and providing communications to allow users to transfer incoming telephone calls remotely.

**BACKGROUND OF THE INVENTION**

A frequent difficulty in an office or similar environment is communicating with a particular individual when they are not in their office but still in the building. This results not only in "telephone tag" where people continue back-and-forth attempts to return telephone calls, but also in its physical analog where one person visits the office of another, only to find that person to be gone.

One solution to this problem has been the increasingly widespread use of paging receivers, and such devices have become more and more miniaturized. Devices have been constructed, for example, that are the size of a credit card or that are included as part of a watch. Such systems, however, are typically one-way, transmitting only a telephone number, perhaps an additional short numeric code, or possibly a brief alphanumeric message, and are designed for use outside a building.

Within a building, there have been two general directions that system designs have taken. One is the use of radio paging systems within a building, which may be configured to allow receipt of electronic mail messages or to allow users to be notified that they have a call that they can then ask to be transferred to a nearby extension. For example, the Hagl invention (U.S. Pat. No. 5,151,930) transmits the fact of the incoming call and the telephone extension of the calling

party by radio to a paging receiver, which indicates to the user that the call has come in and displays the number. The user then locates a telephone instrument and dials a code identifying the user, resulting in the incoming call being transferred to that instrument.

The other direction is the use of automatic personal locating systems that determine where in a building an individual is, and that can automatically route a telephone call to the nearest extension. For example, the Ward invention (U.S. Pat. No. 3,439,320) describes a system that uses ultrasonic sound (using a different frequency for each person) to track the location of individuals in a building so that telephone calls may be routed to them. A number of variations exist using different media. Thus, the Shipley inventions (U.S. Pat. Nos. 4,601,064 and 5,062,151) track the location of individuals that carry devices that repeatedly transmit a digital identifying code via infrared light that is then received by remote sensors installed in individual rooms of a building, with a central computer that polls the remote sensors and determines the location of an individual. Telephone calls can then, if desired, be automatically forwarded to the individual by the PABX system. The individual can, using a switch on the identification device, turn off the forwarding action at a given time if it would be inconvenient.

These approaches have a number of drawbacks. One-way radio paging signals can fail to deliver a messages if the user is in an especially noisy environment, is in a "dead spot" resulting from metal shielding or other interference, or goes outside the range of the transmitter. While these difficulties can be prevented by repeating all transmissions multiple times, this approach does not make efficient use of bandwidth and can also result in considerable delay in receipt of a paging signal or message. One-way communication also does not allow an originator to know whether a message has in fact been received by a user and read, or allow the user to respond. One-way systems that indicate to a user only that a call has come in require the user to find a telephone and dial sufficient digits to cause the call to be transferred, and typically require the caller to be placed on hold during this process, which may be annoying to the caller if the person being paged does not respond or takes a long time to do so.

Systems that automatically track the location of individuals and automatically transfer incoming telephone calls to that location tend to be intrusive, because they necessarily cause a transfer even in circumstances that might be inappropriate (such as transferring a call to an individual who is in an office of someone he or she does not know well or who is in a group meeting that might be disturbed).

The above difficulties are solved by the invention disclosed here (and related inventions) by its provision of both (1) two-way communication and (2) automatic tracking of the location of the individual. This combination allows responses to be sent which are chosen from a set provided with the original message, from a preprogrammed set, or composed by the user. Selection or composition of responses is made easy by use of a thumbwheel that allows display of messages and responses and their choice by pressing a single key (as is described in a copending application). The communication and tracking system also makes possible the transfer of incoming telephone calls remotely by means of selection from a menu.

The present invention provides both two-way communication and tracking by making use of a hybrid communication system with radio used for transmitting data to the user, and infrared light (or, in an alternative embodiment, ultra-

3

sonic sound) used for receiving data from the user. This hybrid system makes effective use of the strengths of each form of communication. Radio is used in one direction for broad coverage, ease of implementation, and relative reliability, while infrared light (or ultrasound) is used in the other direction (for acknowledgements, responses, original messages, and location tracking) because of its low power requirements, simplicity of design, small size of the necessary electronics, low cost, and its ability to determine the location of individuals (since infrared light and ultrasonic sound do not pass through walls). Radio is also desirable because its use could allow the design of a paging receiver that works both with conventional paging systems when outside the building and, in addition, with the system described here when inside the building, using the same components.

The use of this hybrid mix of communication media required the design of a communication protocol to fit the characteristics of the two media. The radio medium is characterized by good but not perfect reliability, and moderate to substantial capacity, depending upon availability of particular bands and whether the station is licensed or unlicensed. The system is particularly applicable for use in the recently allocated 1,900 Mhz band for personal communications services for unlicensed use in a building. The infrared medium has somewhat limited capacity in this context because of the need for data to be transmitted repeatedly and because of the need to minimize drain on the battery and to minimize conflict with other nearby communication units. Ultrasound has a naturally low capacity resulting from its susceptibility to interference from echoes as the signal bounces off walls, floor, and ceiling. Both infrared, and, to a lesser extent, ultrasound, have somewhat variable reliability as the user moves from one room to another and as the unit changes position and orientation in that environment. Infrared and ultrasound, are, of course, desirable because they do not easily penetrate walls and ceilings and thus allow reliable identification of the location of the unit.

One example of the requirements for the protocol is illustrated by the fact that unlike more conventional protocols where data is transmitted and an acknowledgement signal is expected immediately if the data has been correctly received, with this protocol data must be sent without waiting for immediate acknowledgement of previous packets, with data broken down into packets with assigned sequence numbers and both data and acknowledgement packets containing the appropriate numbers. This is necessary because with a hybrid system, one direction can be reliable at a time when the other is not, and vice-versa. Other characteristics of the protocol include modifying the rate of repeated transmissions from units and polling to and transmissions from remote stations depending on the probability of expected responses and the user of indicators to signal to the user the status of the communication links, particularly when communication is being impeded.

#### SUMMARY OF THE INVENTION

The goal of the method and apparatus disclosed here is to provide a communications system that can send paging signals and brief messages to individuals within a building or complex of buildings, accept and deliver responses to these messages, and identify the location of individuals within the building.

Individuals communicate with a central communications station by means of a miniature communications unit carried

4

by the individual that is typically about the size of a credit card and can be integrated into a wearable plastic corporate identification badge. The communications unit displays messages visually and can provide a visual and/or auditory alarm indicating the receipt of a message. Users can view messages and select or compose responses by means of a thumbwheel rotating cylinder and key. The unit consists of a microprocessor, a memory, a radio antenna and receiver, a speaker, a visual display, an infrared diode emitter, a thumbwheel and key, and visual and auditory indicators.

Communication from the central communications station to each individual unit is carried out by frequency-shift-keyed digital radio, with a single radio transmitter and antenna typically used for a single building or building complex. Communication from each unit to the central communications station is carried out by a combination of infrared light and wire or optical fiber. Remote communication stations that include an infrared light sensor are installed in individual rooms of the building and along corridors, and data is sent from the unit first to a remote station by infrared and then forwarded to the central station by wire or optical fiber.

The communications system is integrated into the telephone and electronic mail systems typically found in an office environment. A message may be generated as a result of a telephone ringing signal, the leaving of a voicemail message, or the receipt of an electronic mail message (either messages specifically intended to be sent to the remote unit or messages directed to the user's normal electronic mail address, the latter particularly if the sender or topic of the message matches a description provided by the user).

The system allows others (if desired by a user) to determine the current physical location of the user by sending an appropriate "location query" electronic mail message, with the originator automatically receiving a return message indicating the last known location of the user. The system also allows information from the personal locating system to control the forwarding of an incoming telephone call to an appropriate extension.

While users can compose any response to a message or an original message, the miniaturization of the communications unit tends to make character entry laborious, and the system is designed on the assumption that responses usually involve the selection of preprogrammed responses included in the message, preprogrammed responses that can be selected from the memory of the unit, or very brief responses composed letter by letter. Examples of possible responses include "Message read and understood", "Will do", "Will call you back in 5 minutes", "Will call you tomorrow", etc. Responses are preferably selected or composed by means of a thumbwheel and single key, which takes up little space. The thumbwheel and key interface is described in detail in the copending application entitled "Control of Miniature Personal Digital Assistant Using Menu and Thumbwheel."

The system uses a communication protocol designed for the special characteristics of a hybrid radio-infrared light system. It is assumed that the radio link is usually highly reliable, but that occasional errors and outages may occur due to electromagnetic interference, metal shielding, or movement of the user outside of the range of reception.

Messages are transmitted or held at any given moment depending upon the status of the communication unit and the priority of the message. Units are in one of five status states: (1) Receiving and Responding; (2) Not Receiving but Responding; (3) Not Receiving or Responding; (4) Receiving but Not Responding; or (5) Not Responding, depending

5

upon the conditions of the last response received from a unit. Thus, for example, Ring messages (resulting from incoming telephone calls) are not transmitted to a unit that is Not Receiving or Responding (and thus likely out of the building), but if caller identification information is available for the call, the message is stored so that the user is informed of the call upon returning to the building.

Data transmitted both to and from the communications unit is error checked, with correct receipt ensured by retransmission. However, because the communications medium is different (radio versus infrared light) in different directions, it is frequently the case that at any particular time, the communications circuit is reliable in only one direction. Instead of the usual transmission-acknowledge-or-timeout-retransmission protocol, data is sent in the form of short packets, with each packet given a sequence number. Packets continue to be sent even without acknowledgement if there is reason to believe that a unit may be receiving. Acknowledgements are sent with the corresponding packet sequence number when each packet has been received. If an acknowledgement has not been received from a unit under conditions that suggest that such an acknowledgement would have been received if the original packet had been received correctly, that packet is retransmitted. Acknowledgements are themselves acknowledged by a packet sent to the unit via radio that results in reducing the amount of data the unit must repeatedly transmit, and consequently reducing the possibility of conflict due to overlapping transmissions between different units near the same remote station, and reducing battery drain. Units autonomously and repeatedly transmit an identification signal via infrared together with any acknowledgements or input data that may be queued, with intervals between transmissions varying to reduce conflict between units.

If a user has initiated a response or original message but it has not been successfully transmitted from the unit, the unit indicates this by turning on a "Communications Trouble" indicator to indicate that the infrared signal is not being received, so that the user can change the position or orientation of the unit to reestablish contact. The indicator is similarly turned on if packet sequence numbers indicate that a message should have been received but has not so that the central station can more quickly become aware of this and retransmit it.

An alternative embodiment of the system uses ultrasound rather than infrared light as the communications medium for sending data from the communications unit to the remote station.

In a second alternative embodiment, data is not transmitted autonomously from the communication unit, but in response to a poll received via radio.

#### BRIEF DESCRIPTION OF THE DRAWINGS

FIG. 1 shows a block diagram of the hardware for the communications system, showing the central communications station, PABX system, electronic mail server, radio transmitter, some of the remote receiving stations, and one of the communication units carried by users.

FIG. 2 shows the configuration of infrared detectors and associated remote communications stations in different rooms of a building and along a corridor, with each detector and station shown as a circle.

FIG. 3 is a block diagram that shows the hardware architecture of the communications unit.

6

FIG. 4 shows a front view of the physical layout of the remote communications unit.

FIG. 5 is a rear view of the unit, showing an additional infrared emitter optional corporate and employee identification information and a clip for attaching the unit to the user's clothing.

FIG. 6 is a side view of the unit, showing the infrared emitters (or ultrasonic transducers) liquid crystal display and clip.

FIG. 7 shows the format of a message sent to the communications unit and how it is broken down into packets for transmission.

FIG. 8 shows the format of a Data packet.

FIG. 9 shows the format of an Input Acknowledgement Packet.

FIG. 10 shows the format of an "AckAck" or "acknowledgement of an acknowledgement" packet.

FIG. 11 shows the format of a Confirm Data packet.

FIG. 12 shows the format of packets sent from the communications unit to one or more remote stations via infrared light.

FIG. 13 shows the format for a Poll packet that is sent from the central communications station over a wire or optical fiber link to all remote communications stations.

FIG. 14 shows the formats of a packet sent from a remote station via the wire or optical fiber circuit in response to a poll.

FIG. 15 shows the format of message text sent from the Central Station to a Communications Unit, including particularly the responses that can be selected to that message.

FIG. 16 shows the format of a message defining preprogrammed responses, messages, and email addresses.

FIG. 17 shows a flowchart of the software architecture for the central communications station.

FIG. 18 shows a flowchart of the software module in the central communications station that processes incoming electronic mail messages.

FIG. 19 shows a flowchart of the first part of the communications software for the central station that processes packets received from the remote station.

FIG. 20 shows a flowchart of part of the communications software for the central station that processes the part of packets from the remote station that contain input data.

FIG. 21 shows a flowchart of the part of the communications software for the central station that selects and sends Data and other nonpoll packets to communications units via radio.

FIG. 22 shows a flowchart of the real-time clock interrupt module.

FIG. 23 shows the format of the Unit Status List.

FIG. 24 shows the Message to Unit Queue, which holds messages to be sent to units.

FIG. 25 shows the data structure of the Packet to Unit Queues, including Queues A, B, C, D, E, F, and G.

FIG. 26 shows the data structure of Poll Queues A, B, and C.

FIG. 27 shows the data structures for the Email Incoming Message Queue, the Email Incoming Message Archive, and the Email Outgoing Message Queue.

FIG. 28 shows the data structures for the maps between email addresses and unit IDs and channels.

FIG. 29 shows the data structure for the Input Data from Unit Queue, which holds packets received from a communications unit.

FIG. 30 shows the data structures that hold the preprogrammed responses, messages, and email addresses.

FIG. 31 shows the data structures for the Time Event Queue.

FIG. 32 shows the layout of the lamps, display and cursor, key, and thumbwheel on the front side of the remote unit.

FIG. 33 shows a variety of displays illustrating different situations and the interface presented in each situation.

FIG. 34 shows a flowchart of the architecture of the software for the communications unit.

FIG. 35 shows a flowchart of the part of the software module in the communications unit devoted to processing incoming packets that have been received by the unit via radio.

FIG. 36 shows a flowchart of the part of the software in the communications unit that processes displayable incoming Data packets that have been received.

FIG. 37 shows a flowchart of the first part of the clock interrupt software for the microprocessor in the communications unit.

FIG. 38 shows a flowchart of the last part of the clock interrupt software for the microprocessor in the communications unit.

FIG. 39 shows the data structure for the Incomplete Message Packet Map.

FIG. 40 shows the data structure for the Packets Unassigned to Messages List, used in the software in the communications unit.

FIG. 41 shows the data structures for the Packet Text List.

FIG. 42 shows the data structure for the Display Memory and the associated Display Window.

FIG. 43 shows the data structures for the Input Data Queue, Packet Acknowledge Queue, and Unit Transmission Buffer.

FIG. 44 shows a flowchart of the software for the microprocessor in the remote communications station.

#### DESCRIPTION OF THE PREFERRED EMBODIMENT

FIG. 1 shows a block diagram of the hardware for the communications system, showing the central communications station, PABX system, electronic mail server, radio transmitter, some of the remote receiving stations, and one of the communication units carried by users.

The central communications station 3, which consists of a 16-bit microprocessor, memory, a 1 khz real-time clock, and appropriate communication interfaces, transmits messages in the form of digital bitstreams by means of the frequency-shift-keyed radio transmitter 4 and antenna 5. A message is received by communications unit 6, which decodes it, enters the messages into its internal memory, and displays the message visually and turns on visual indicators and/or auditory alarms, as appropriate. The unit will also generate an acknowledgement for each message that is sent to the central station.

Each communications unit 6 transmits an identification code in the form of digitally encoded infrared light, which is received and stored by one or more remote stations 7, 8, and 9 receiving it. Other data, such as acknowledgements of received messages, responses, or original messages are also included with the identification signal when available. The central station periodically polls, by means of a two-way wire or optical fiber communication circuit, each remote

station and receives in return the identification code and any additional data that the station has received from one or more communication units. Each remote station consists of one or more photodiode infrared detectors, an analog-to-digital converter, a microprocessor, memory, and serial communications interfaces.

The two primary sources of messages are the electronic mail network and incoming telephone calls. An incoming electronic mail message is transmitted by a remote workstation through an electronic mail server 1 and to the central communications station 3, which transmits the message via radio 4 to the appropriate communications unit 6. The user can, if desired, choose a response that will be transmitted back to the originator of the message.

An incoming call to the user's extension enters the PABX system control 2, with the call indication, extension number called, calling number and any further identification of caller, if available, passed to the central communications station 3 and then transmitted by radio 4 to the communications unit 6.

The user may select a response, which is passed by infrared light to a remote station 7 (with a code added to identify the remote station), with the response sent to the central communications station 3 and then to the PABX control 2, which can, if desired, initiate a call transfer, either to a receptionist, to a voicemail system, to the extension where the user is located, or to another extension.

(In an alternative embodiment, ultrasound is used instead of infrared light for communication from the communications unit 6 to the remote stations 7, 8, and 9. In this case each remote station has an ultrasonic microphone and appropriate signal processing hardware instead of a photodiode infrared detector. In the remainder of this application, references to "infrared light" can generally be interpreted as meaning "infrared light or, in an alternative embodiment, ultrasound.")

FIG. 2 shows the configuration of infrared detectors and associated remote communications stations in different rooms of a building and along a corridor, with each detector and station shown as a circle. Station 15, for example, is installed in an office, while station 16 is installed in a corridor. Infrared detectors may be mounted on walls or on the ceiling, and more than one detector may be used in a given room to provide more reliable coverage.

FIG. 3 is a block diagram that shows the hardware architecture of the communications unit.

All of the integrated circuits in the communications unit are especially miniature, lightweight, and have low power consumption. The radio signal broadcast from the central communications station is picked up by the antenna 21 and passed to the radio receiver 22 and to the frequency-shift-keyed detector 23. The radio signal has a frequency of approximately 1,900 Mhz, using the band recently assigned for unlicensed use in buildings for personal communications services. (Until this band becomes fully available more conventional bands can be used). The output of the FSK detector is applied to a shift register and associated logic 24 which converts the 4800 bit/second bit serial data to 8-bit parallel form before providing it to the microprocessor 25, generating an interrupt when each character is received.

The microprocessor itself 25 is a 8-bit processor. A Colpitts crystal oscillator 26 operating at 3.932 Mhz provides a real-time clock signal directly to the microprocessor at this frequency and also to frequency dividing counters 27 that provide a 76.8 khz (16 times the 4800 bit/second bit rate) clock signal to the asynchronous character receiver

(shift register) 24, a 38.4 khz clock signal to an asynchronous character transmitter 28, and a 1.2 khz clock signal to the microprocessor for use as a clock generating an interrupt for use with timing of the thumbwheel position encoder and auditory and visual indicators. The thumbwheel position is sampled 18.75 times per second. (A different clock frequency is provided for the transmitter 28 in the case of ultrasonic transmission).

Associated with the microprocessor is a programmable read only memory (PROM) 30 with 4K bytes of storage, and a random access memory (RAM) 29 with 8K bytes of storage. The PROM contains the program for the microprocessor while the RAM contains messages after conversion to digital codes, information extracted from the messages for display to the user, and other information.

Software in the microprocessor extracts information to be displayed, which is placed into a memory and causes characters to be displayed on the liquid crystal display 31. The display also includes indicators indicating that a message is available and its priority. Lamps 38 and 39 also indicate when there is a Ring or Urgent message or indicate the status of the communications circuit. In addition, an auditory bit, audio amplifier, and speaker 37 can provide an auditory alarm. A thumbwheel 32 allows the user to display messages and responses that are stored in memory. The thumbwheel is sampled by an encoder 33 that sends a 10-bit representation of its position to the microprocessor. A user may also press the control key 34 to send a response to a message, to transmit a message, to select a command, or to delete a message.

Data from the communications unit is sent at a rate of 38,400 bits per second, with the microprocessor sending each 8-bit character to the asynchronous transmitter 28, which sends each bit to a driver 35 and to an infrared emitter diode 36. (More than one emitter may be used to provide coverage in different directions). (In the alternative embodiment using ultrasound, the driver and infrared light emitter is replaced by an ultrasonic frequency synthesizer, pulse encoder, amplifier, and ultrasonic transducer.)

When an auditory signal is desired to alert the user, the microprocessor produces it by toggling an Auditory Output Bit at an auditory signal rate that is amplified by an operational amplifier and speaker 37.

FIG. 4 shows a front view of the physical layout of the remote communications unit. At the very top left are infrared diode emitters 40, and 41 (replaced by one or two ultrasonic transducers in the alternative embodiment using ultrasound). Lamp 42 at the top indicates when a Ring or Urgent message has been received, with the lamp flashing at a rate of two flashes per second indicating a Ring and the lamp flashing at a rate of one flash every two seconds for 20 seconds, then turning solid, indicating an Urgent message. At the far right is the Communications lamp 43, which indicates the status of the communications circuits. If the lamp is turned on for any significant period of time, it indicates trouble. If a user has sent input data (i.e., responded to a message) but has not received an acknowledgement of it, the lamp is solidly on. If the unit has failed to receive data and no response from the unit has been received recently, the lamp is also turned on. In contrast, a momentary flicker (150 mS) of the lamp indicates a successful transmission from the unit. Just below is the liquid crystal display 44, with a mark at the center left of the display that serves as a cursor 45 indicating the response being selected or the message being deleted. Below the display is an optional identification photo 46, included when the communications unit is incorporated into a cor-

porate identification badge. At the bottom left is a speaker 47 capable of emitting sounds in the sonic range to serve as an auditory alarm. At the bottom center is a key 48 used for deleting messages, for sending a response that has been selected, for executing preprogrammed commands, and for making other selections depending upon the context. At the bottom right is a thumbwheel—a small cylinder 49 that can be rotated either up or down by the user's thumb that is used to control the display of messages, responses, and other information.

FIG. 5 is a rear view of the unit, showing an additional infrared emitter 51, optional corporate and employee identification information 52 and a clip 53 for attaching the unit to the user's clothing. An access plate 54 for replacing the battery is also shown.

FIG. 6 is a side view of the unit, showing the infrared emitters (or ultrasonic transducers) 51, 40, and 41, liquid crystal display 44, and clip 53.

FIG. 7 shows the format of a message sent to the communications unit and how it is broken down into packets for transmission. The upper part of the figure shows the message text, which begins with an STX 71, followed by a 7-bit channel number 72 (assigned when the first packet in the message is placed in the queue for transmission), the actual text of the message 73, ending with an EOM 74.

The message text may include special characters designating specific situations, such as the receipt of a Fax, voicemail message, or Print job, that causes indicators in the communications unit to be displayed. If the entire message stored in the Email Incoming Message Archive is not contained in the message, an ASCIIETB character just before the EOM indicates this.

The message text is broken up into from 1 to 8 packets, depending upon the length of the message, with the example shown a message with 3 packets. Each packet can hold a maximum of 42 data characters. The bottom part of the figure shows how the message text 73 is divided up and placed into packets 75, 76, and 77, with header and error check information added to the beginning and end of each packet.

FIGS. 8-11 show the data formats associated with the transmission of data in packets from the central communications station to the communication units and in the return direction.

FIG. 8 shows the format of a Data packet. The packet begins with an ASCII start-of-header (SOH) character 78, with the higher order bit (which is sent last) set to 0. All data in the figures showing packet formats show 7-bit characters for simplicity; however, each character transmitted is actually 8 bits in length (plus start bit and stop bit for a total of 10 bits). The 8th (higher order) bit is set to 1 except in two cases: An SOH character and an ASCII end-of-transmission (EOT) character. The character following the SOH character in the Data packet contains 2 bits designating the packet type 79 (00 if Data, 01 if Input Data Acknowledgement, 10 if AckAck, and 11 if Not Responding). Two following bits in the character are used to indicate the priority of the packet 80 (Ring, Urgent, High, or Normal). The remaining 3 bits of this character and the 7 bits of the following character contain a 10-bit identification field 81 designating the communications unit. The two characters following that 82 contain a 14-bit Packet Sequence Number (7 bits in each character), followed by from 1 to 42 data characters 83, a 7-bit cyclic redundancy check (CRC) 84, and an EOT 85. The first 2 bits of the Packet Sequence Number are the same as the packet priority. A data packet thus has a total of from 8 to 49 characters.

## 11

FIG. 9 shows the format of an Input Acknowledgement Packet. This packet is received by the unit via radio. There are two forms of this packet: InputAck and UnitAck. An InputAck acknowledges an Input Data packet sent by the unit. A UnitAck acknowledges the ID sent by the unit if input data is not sent. The packet begins with an SOH character 87, with the following character consisting of the following fields: A 2-bit field indicating the packet type 88 (Data, Input Data Acknowledge, AckAck, or Not Responding), a bit 89 indicating whether this is an InputAck or UnitAck, an unused bit 90, and 3 bits 91 for the upper 3 bits of a 10-bit identification field designating the communications unit. The following character contains the remaining 7 bits 92 of the unit ID, and the character following that 93 a 7-bit Input Packet Number, a packet sequence number for the input data packet that is being acknowledged. The character after that 94 is a CRC and the character following that is an EOT 95.

FIG. 10 shows the format of an "AckAck" or "acknowledgement of an acknowledgement" packet. This packet is received by the unit via radio, and its purpose is to cause the termination of repeated transmissions of acknowledgements from the communications unit. The packet begins with an SOH character 97, with the following character consisting of the following fields: A 2-bit field indicating the packet type 98 (Data, Input Data Acknowledge, or AckAck), 2 unused bits 99, and 3 bits 100 for the upper 3 bits of a 10-bit identification field designating the communications unit. The following character contains the remaining 7 bits 101 of the unit ID, and the two characters following that 102 and 103 a 14-bit Packet Sequence Number for the data packet for which an acknowledgement has been received. The character after that is a CRC 104 and the character following that 105 is an EOT.

FIG. 11 shows the format of a Confirm Data packet. This packet is sent via radio to the communications unit at frequent intervals to confirm that all Data packets sent (except Ring packets) have been received by the unit. The packet begins with an SOH character 106, with the following character consisting of the following fields: A 2-bit field indicating the packet type 107 (11 if Confirm Data), 2 unused bits 108, and 3 bits for the upper 3 bits of a 10-bit ID field 109 designating the communications unit. The following character contains the remaining 7 bits of the unit ID. The following two characters contain the last packet sequence number transmitted for the Urgent priority 110, the next two the same for the High priority 111, and the next two the same for the Normal priority 112. The following character 113 contains the time since a response has been received by the unit, in tenths of a second. The character following that 114 contains a CRC, and the final character 115 an EOT.

(In an alternative embodiment in which transmission from the communications unit is initiated in response to a poll from the central station rather than autonomously, a new type of packet, the Unit Poll packet, is defined. This packet uses essentially the same format as the Confirm Data packet used in FIG. 11. In this case, both Confirm Data and Unit Poll packets have a Packet Type of 11 as identified in field 109. However, bits from field 110 unused in the primary embodiment are used to designate whether the packet is a Confirm Data or a Unit Poll packet, with 00 indicating a Confirm Data packet and 01 indicating a Unit Poll packet.)

FIG. 12 shows the format of packets sent from the communications unit to one or more remote stations via infrared light.

The top diagram in the figure shows the general structure of the packet, including an SOH character 116, a 3-character

## 12

header/ID sequence 117, an acknowledge sequence 118 of 1 or 2 characters, input data 119 of 3 to 32 characters, a CRC character 120 and an EOT character 121. The acknowledge sequence and input data sequence are optional, as indicated by the bits set in the header/ID sequence.

The diagram just below shows details of the header/ID sequence. The first character consists of the following fields: A 2-bit field 122 indicating the acknowledgement type (00 indicates that no acknowledgement is being transmitted, 10 indicates that a single packet is being acknowledged, while 11 indicates that more than one packet, in a continuous sequence, is being acknowledged), a 1-bit field 123 indicating whether or not input data is being transmitted, 1 bit that is unused 124, and 3 bits of the 10-bit unit ID code 125. The second character consists of a single 7-bit field with the remaining 7 bits of the ID code. The third character contains a 7-bit field 126 containing a number representing the calculated reliability of the radio transmission being received by the unit.

The two diagrams below the header/ID sequence show the two alternative formats for sending an acknowledgement of a data packet received by the unit. In one format 128 a single data packet is acknowledged (with a two-character sequence containing the 14-bit packet sequence number of the data packet). In the other format a continuous sequence of packets is acknowledged, with the first two characters containing the 14-bit packet sequence numbers 129 of the beginning packet being acknowledged and a 7-bit field in the third character 130 containing the length of the sequence being acknowledged.

The next diagram shows the format of an input data sequence, including a 7-bit Input Packet Number 131 in the first character of the input data packet, a 7-bit channel number 132 referring to the original packet that this is a response to (with the number set to 0 if this is an original message and 1 if a response to a message from the PABX control) and 1-20 characters of data 133.

A specific form of the Input Data Sequence 131, 132, and 133 includes as data only a single ASCII DEL character, indicating that the user has deleted the message referred to by the channel number and that the channel number should be deassigned and the message deleted from the Email Incoming Message Archive. Another form has two DEL characters in succession, indicating an Undelete—that is the previous Delete command is to be reversed.

The next two sequences show the input data formats. There are two formats, a two-character compressed fixed length sequence, and a variable length sequence. The two-character sequence consists of an ASCII character 136 indicating the type of code, followed by a 7-bit character 137 indicating the particular code. The ASCII characters used for indicating code type are ENQ, BEL, BS, HT, and VT.

If the type character 136 is an ENQ, this is a Response Code. If the 7-bit code that follows 137 is from 0 to 19, the response indicates one of the responses (with 0 referring to the first response, 1 to the second, etc.) included with the message sent to the unit. If the code 137 is from 21 to 127, the response indicates one of the preprogrammed responses in the Preprogrammed Response List. If the code is 20, it indicates that the user has selected the \*MORE\* response to obtain more of the email message. (The Preprogrammed Response List, Preprogrammed Message List, and Preprogrammed Email Address List are contained in data structures in both the Central Station and Communications Unit.) If the type character 136 is a BEL, this is a response but using one of the preprogrammed messages in the Preprogrammed



13

Message List, as indicated by the code 0-127. If the type character is an HT, this is a command code, with the code as indicated by the code character 0-127 and retrieved from a hard-coded Command List. If the type character is a VT, this is an Email Address code, with the code as indicated by the code character 0-127 and retrieved from the Preprogrammed Email Address List. Multiple addresses can be used by providing additional character sequences. If the type character is a BS, this is an original message, with the message as indicated by the code 0-127 and retrieved from the Preprogrammed Message List. The message will be sent to the email address sent in the same or previous transmission of input data.

If the type character is a FF, SO, or SI, this is a variable-length (uncompressed) sequence, which consists of a type character 138, 1 to 30 characters of text 139, followed by an ETX character 140. An FF indicates a composed response, SO a composed message, and SI a composed Email Address. Multiple email addresses can be used by using additional character sequences.

FIG. 13 shows the format for a Poll packet that is sent from the central communications station over a wire or optical fiber link to all remote communications stations. The Poll packet is 5 characters in length, and includes an SOH character 151, a 4-bit unused field 152, the 10-bit address of the remote station ID 153 (different than the ID of the communication units), with 3 bits in one character and 7 in the other, a 7-bit CRC character 154 and an EOT character 155.

FIG. 14 shows the formats of a packet sent from a remote station via the wire or optical communications circuit in response to a poll.

The top two diagrams show the two possible forms of the packet. One is a single NAK character 161, indicating that the station has not received any signals from any unit for a timeout period (the last 4096 seconds, somewhat more than an hour). The other begins with an SOH character 162 and has a subpacket for each unit that it has received a signal for within the timeout period (two are shown in the FIG., 163 and 164), a CRC character 165, and an EOT 166.

Each subpacket consists of the fields shown: A 2-character Header/ID sequence 171, a 2-character elapsed time sequence 172, and ACK sequence of 1 or 2 characters 173, Input Data of 3 to 22 characters 174, a Signal Reliability field 175 7 bits in length (from the same field in the Header ID sequence from the unit), a Signal Amplitude field 176 (indicating the amplitude of the infrared signal as received from the unit at the remote station), and an ETX character 177.

The Header/ID sequence consists of a 2-bit Ack Type field 178 (00 if no acknowledgement transmitted, 01 if a single packet is being acknowledged, 10 if a sequence of packets is being acknowledged), a 1-bit field indicating whether input data is being transmitted 179, 1 bit that is unused 180, and 3 bits of the 10-bit Unit ID code 181. The second character consists of a single 7-bit field with the remaining 7 bits of the ID code.

The Elapsed Time sequence consists of 2 characters 182 and 183, with each character holding 7 bits of a 14-bit code representing the elapsed time in seconds (0-4095) since the remote station has received a packet from a given communications unit.

The ACK and Input Data sequences are formatted as shown in FIG. 12.

FIG. 15 shows the format of message text sent from the Central Station to a Communications Unit, including par-

14

ticularly the responses that can be selected to that message. The message text 191 is followed by an ETX character 192, then the first response 193, with successive responses 195 and 197 separated by ETX characters 194 and 196, and with the final response followed by an EOM character 198. Note that there is a maximum of 20 responses for any message. The message text, and particularly, responses are formatted with newline characters terminating each physical line, should the text or response exceed the capacity of a single line. An ETX character terminates a response or message text and also terminates the physical line. If there are no responses, the message is terminated by an EOM. (A newline character is an ASCII carriage return.)

FIG. 16 shows the format of a message defining preprogrammed responses, messages, and email addresses. This data is sent from the central station to the communications unit to define the preprogrammed responses, messages, and email addresses that can be selected by the user. The definition character 201 is an ASCII ENQ, BS, or VT, depending upon whether a set of responses, messages, or email addresses are being defined, respectively. Following that are the separate responses 202, 204, and 206, separated by an ETX character 203 and 205, and terminated by an EOM character 207. As above, responses are formatted with newline characters terminating each physical line, should the response or message exceed the capacity of a single line. An ETX or EOM character terminates a response or message and also terminates the physical line.

FIG. 17 shows a flowchart of the software architecture for the central communications station. Software is divided into a number of different modules, of four different types: (1) PABX modules for processing messages to and from the PABX related to telephone calls; (2) Email modules for processing messages received via the electronic mail system or sent through that system; (3) Communications modules for handling the transmission of data to the communication units via radio and for handling communication with remote stations, including the receipt of acknowledgements and input data and necessary polling and other functions; and (4) A clock module that initiates certain events at appropriate times. In all cases a module is entered as the result of a particular test being passed; if the test is not passed control is passed to the next test. When a module has completed processing program control passes to the first test 211.

A test is first made 211 of whether an incoming message has been received from the PABX Control. An interrupt service routine receives characters that constitute messages from the PABX, which can be either a message reporting an incoming call or a message reporting that a particular extension has gone on-hook or off-hook. When the last such character in a message has been received a flag is set indicating to the main program that a message has been received, and the PABX module is then called 212 to process it. An incoming call message will result in any additional caller ID information that may be available at the central station being added and result in the creation of a list of extensions that the user could transfer a call to. The message created for transmission to the unit is then placed in the Message to Unit Queue, and the first packet of that message placed in one of the Packet to Unit Queues. An on-hook or off-hook message is not sent to the communications unit, but changes the Extension On-Hook List, which records the on/off-hook status of each extension, which is used in evaluating whether a given extension might be available for transferring a call.

A test is then made 213 of whether a message has completed transmission to the PABX. If so, a test is made

15

214 of whether another message is available to be sent to the PABX. If yes, that transmission is initiated 215.

A test is then made 217 to see if an electronic mail message has been received over the local area network connecting the central station with computer workstations. If so, a module is called to process 218 the received email message. An interrupt service routine receives each character from the network, with the end of a message resulting in a flag being set indicating that a message is available to the main program in a buffer memory. Electronic mail intended for a communications unit is sent to a pseudoaddress similar to the normal address of a user. For example, if a user's address is "peterson@cogdes.com", the user's communication unit address might be "peterson%pager@cogdes.com", with all such messages forwarded by email system to the central station. If such a message has arrived, the central station looks up the address to see if it is a legitimate user; if not an error message is returned to the originator of the message. If the user exists, the entire message is placed in the Email Incoming Message Archive. The message is then processed to extract only the most significant information (stripping off most of the header data) and also to extract only the first part of long messages. In addition, if the sender has indicated a set of responses for the communications unit user to choose from, these are extracted, formatted, and added to the message. The resulting message, together with the unit ID, is placed in the Message to Unit Queue and the first packet of the message extracted and placed in the appropriate Packet to Unit Queue depending upon its priority. Details of this can be found in FIG. 18 and the associated text.

A test is then made 220 to see if an outgoing electronic mail message has completed transmission (and another can be sent). If yes, a test is made 221 to see if another message is available (in the Email Outgoing Message Queue) to be sent. If yes, the message is initiated 222. An electronic mail message transmission is initiated by the central station in the following way: The message is placed in a buffer memory and the first character in the message transmitted to the electronic mail interface hardware. The completion of transmission of each character causes an interrupt handler to obtain the next character and transmit it, with the handler setting a flag when the message has been completely sent. When a new message is to be sent, the message that has been in the queue the longest is selected.

A test is then made 223 of whether a response has been received (to a previously transmitted Poll packet) from a remote station. If so, a module is called 224 to process it and send another Poll packet. If the response is a successfully error checked packet, a subpacket for each communications unit that sent a response is extracted. For each acknowledgement included in the subpacket, the original packet is deleted from the appropriate Packet to Unit Queue, an AckAck (acknowledgement of an acknowledgement) packet is placed in the appropriate Packet to Unit Queue, and, if there is another packet in the original message, that Packet is also placed in a Packet to Unit Queue. If input data is included in the subpacket, that data is routed to the appropriate destination (email server, PABX, or other communications unit), and an Input Acknowledge packet placed in the appropriate Packet to Unit Queue. If message has been deleted from the unit memory, that message is also deleted from the Email Incoming Message Archive, and the channel is deassigned. (The information is saved in a temporary store in case the user performs an Undelete operation). If a unit was previously not receiving or responding (i.e., likely out of the building), Data packets that were on hold because of

16

this tagged to be selected and sent. After the response from that station has been processed, or if the response is a NAK character or a timeout has occurred before a successfully error checked packet has been received, a new poll packet is selected and initiated. Details can be found in FIGS. 19 and 20.

A test is then made 225 of whether a packet has completed transmission to the unit via radio. A packet to be sent is then selected from those in the Packet to Unit Queues, or, if the queues are all empty, a short dummy packet is sent to a dummy unit address. The packet selected depends on a calculation of the relevant urgency of transmitting different packages in queues with different priorities (which are related to the priority of the packet, Ring, Urgent, High, or Normal). The status of the communications unit—whether it is receiving data and responding, whether it is not responding and not likely to be receiving (because of being out of the building)—is also a factor, as is the priority of the packet, with Ring packets, for example, not transmitted if the unit is out of the building. A selected packet is formatted and sent 226 and the polling frequency increased for those stations likely to be near the unit. For more details, see FIG. 21.

(In an alternative embodiment, in which transmission are not made automatically under the control of a timer in each unit, but are made in response to a Poll packet transmitted from the central station to the unit by radio, the selection of a packet to send includes these unit poll packets, as opposed to station poll packets described elsewhere and sent via wire or optical communication).

Finally, a test is made 227 of whether a clock event has occurred. The Time Event Flag is first tested to see if another second has elapsed. If so, that flag is cleared and the Clock Event Queue is tested to see if one or more events are to be executed at the current time.

If the event is a Station Poll Queue Timeout (meaning that a given station has remained in a particular Poll Queue for the prescribed length of time), the given queue and station ID are retrieved, and the appropriate item moved from one queue to another. If the queue the item is being moved to is Queue B, the item in the Clock Event Queue has its queue changed to B, its time set to 900 seconds after the current time, and the item moved to the end of the queue. If the queue the item is being moved to is Queue C, the entry in the Time Event Queue is deleted.

If the event is a Unit ID Response Timeout, the Unit Status field in the Unit Status List is updated (to indicate that the unit is not responding), and Packet to Unit Queues are checked for packets addressed to that unit that have the Waiting for Ack bit set. For each such packet, the Waiting for Ack bit is set to 0. If the status of the unit is Not Receiving or Not Responding, the Hold bit is set to 1. If there are one or more Data packets with Hold bits set, a Confirm Data packet is moved from Packet to Unit Queue G to Packet to Unit Queue F, if it is not already in Queue F.

After processing the clock event 228, program control returns to the start of the program.

FIG. 18 shows a flowchart of the software module in the central communications station that processes incoming electronic mail messages. Incoming email arrives through the Email Server as a result of it being addressed to a pseudoaddress (e.g., "peterson%pager") associated with the user's normal email address (e.g., "peterson"). This may be a result of the originator of the message sending the message specifically to the communications unit (using the pseudoaddress) or the originator sending a message to the normal message address with a copy to the communications unit. It

may also result from the user's workstation having email software set up to forward certain messages automatically. This may be all messages from a certain sender, all with certain keywords in the subject line and/or text, messages with a certain (e.g., urgent) priority, or a combination of the above.

A test is first made **231** of whether the email address is legitimate by looking it up in the Email Address to Unit ID Map. If the address is not found, a response message is generated **241** to the sender indicating that a communications unit is not active for that address, the response message placed in the Email Outgoing Message Queue, and the module is done.

If the email address is legitimate, a test is made **232** of whether the message is a request for the user's present location, a maintenance message from the user or system administrator, or a message intended for a user. (A location request message has "%" as the first 2 characters in the message text, and no other characters, while a maintenance message has "%\$" as the first 2 characters in the message text, and no other characters on that line.)

If the message is a location request, the present location of the communications unit and the time the unit last responded is looked up in the Unit Status List **233**, a response email message containing this information is sent to the originator, and the module is done. (If the user has set privacy mode, the response says only "Privacy Mode Set").

If the message is a maintenance message, the user's or system administrator's password (contained in encrypted form in the message) is checked and, if the originator has the appropriate privileges, the appropriate changes are made **234**, a response message sent **235** verifying the changes, and the module is done. Changes to and queries of tables that define users, user IDs, telephone extensions, and locations and telephone extensions near remote stations are made using a simple set of commands contained in email messages that can be originated at any workstation connected via the email server to the system. Users can also define preprogrammed responses, messages, and email addresses, and set parameters, in this way.

If the message is intended for a user's communications unit, the first 2048 bytes of the message are entered **236** into the Email Incoming Message Archive, which allows users access to substantial parts of most messages. While most traffic is likely to involve very short messages, there are situations (such as a user stuck in a meeting) where a user may want to read a longer message via the communications unit.

The most significant information in the incoming message is then extracted **237** and packed into the first message to the unit (up to 128 bytes if it is the first part of an incoming message; up to 336 bytes if a user has requested more data from a message stored in the Email Incoming Message Archive). This is done by identifying separate lines in the header message and taking only the text in the subject line, the email address of the sender, message text, and the signature at the end of the message. In addition, canned responses that have been added to the message by the sender (either by the person originating the message or by a software message-sending tool that automatically appends appropriate responses) are extracted, tagged appropriately, and added to the end of the extracted text. The first such response is identified by a "!" character in the first column of the line. When this character is found, the remaining characters on the same line are considered the first response, and each following line (with a newline character, defined as

an ASCII carriage return, indicating a new line) containing an additional response. A priority is then assigned **238** to the message, either Urgent, High, or Normal. An Urgent priority is given when it is specified by the originator of the message (with % Urgent as the first text of the message indicating this). The user can also cause messages from certain email addresses to be sent as Urgent. Messages sent to the communications unit directly are given a High priority, while messages forwarded from the user's workstation are given a Normal priority. Other criteria for assigning priority levels are also possible, and such criteria could be modified by the user. Examples include the length of the message, priority codes that are part of the email header, specific words indicating topics of particular interest, etc.

A channel number is then assigned **239** for this particular message. This is done by scanning the Channel to Email Address Map until an unassigned channel is found, and assigning that channel to the incoming message. The Assigned Bit is set to indicate that the channel is being assigned, the email address of the message originator is entered, and a pointer to the Incoming Email Message Archive that designates the beginning of the message is entered, all in the Channel to Email Address Map.

The compressed form the message (with the channel number the first byte after the STX) is then placed **240** in the Message to Unit Queue, and the first part of the message (up to 42 characters) defined as the first packet and placed in the appropriate Packet to Unit Queue, depending upon the priority of the message.

FIG. 19 shows a flowchart of the first part of the communications software for the central station that processes packets received from the remote station.

A test is first made **251** of the form of the response from the station. There are three options: (1) A packet has been received and successfully error checked; (2) A NAK character has been received; and (3) A Station Response Timeout has occurred (identified by testing the Station Response Timeout Flag) before one of the above has been received.

If the response is a packet with a correct error check, control passes to point **1**.

At point **1**, the next unit subpacket is extracted **252** from the packet, and the unit ID for that subpacket is also extracted.

The station ID, current time, signal reliability, and signal amplitude is then saved **253** in the Unit Status List for the unit involved and the station the response was received from.

A test is then made **254** of the Unit Status, obtained from the Unit Status List. If the status has changed from that stored, and the new status is Receiving and Responding, the Packet to Unit Queues are scanned for packets for the unit that are on hold, the Hold tag is removed **255** from any such packets, and control passes to point **2**. Otherwise, control passes immediately to point **2**.

At point **2**, a test is made **256** of whether an acknowledgement sequence is included in the unit subpacket. If yes, control passes to point **3**. If an acknowledgement sequence is not included, a test is made **257** of whether sufficient time has elapsed (i.e., a timeout) since the transmission of the packet for an acknowledgement to be expected. If yes, the "Wait for Ack" tag bit is removed **258** from any such packets (to allow then to be retransmitted if the Hold bit is not on). If the new unit status is Not Receiving but Responding, the Hold bit is also set for those packets with High or Normal (but not Urgent) priority, so that an attempt to transmit will not be made until the unit status has changed. Control then passes to step **259**.

If a unit response timeout is not presently in the Time Event Queue, a unit response timeout request is then entered 259 in the Time Event Queue, with the time set to the current time plus 90 seconds. If a request is already in the queue, its time is reset to the current time plus 90 seconds. Program control then passes to point 5 in FIG. 20.

At point 3, the packet number of a packet needing acknowledgement is extracted 261 from the subpacket (including intervening packet numbers if a sequence of numbers is specified). An AckAck packet for each acknowledgement data packet is then placed 262 in Packet to Unit Queue C. In addition, each original packet is deleted 263 from its original Packet to Unit Queue. If another packet is contained in the message, that packet is extracted and entered 264 in the appropriate Packet to Unit Queue.

A test is then made 265 of whether there are more acknowledgements in the subpacket. If yes, control passes to point 3. If there are no more acknowledgements in the subpacket, a test is made 266 of whether there are other packets still waiting (in Hold mode) that have not been acknowledged. If yes, the Data Confirm packet for the unit is moved 268 to Packet to Unit Queue F if it is not in that queue already. Control then passes to step 257. If no, the Data Confirm packet is moved 267 to Packet to Unit Queue G if it is not in that queue already. Control then passes to step 257.

If the response from the station in test 251 is a NAK or some response other than a successfully error checked packet after the timeout period of 50 mS (indicated by the Station Response Timeout Flag being set), control passes to point 4.

At point 4, the next Poll packet to be sent is first selected 271. This is done as follows: There are three queues (Poll Queues A, B, and C) that hold poll requests, with each remote station ID entered into one of the queues at any given time, depending upon the activity of units near each station. For each queue, a pointer indicates the "next" station ID in the queue, which is the station for which the greatest amount of time has passed since being polled. (This pointer is reset to the top of the queue after the bottom ID in the queue has been polled—the queue is circular, with stations continuing to be polled as long as they are not specifically removed from the queue.) For each of the three queues, the next station is retrieved, including the time that a poll was last sent to that station. A calculation is then made of the "urgency" for each of the three stations, with urgency a measure of the extent to which not sending a poll would result in allowing performance to lag behind what is expected for a particular queue. The calculation is made with the following formula:  $urgency = t_{actual} / t_{expected}$ , where  $t_{actual}$  is the actual time elapsed since the last poll was sent to the given unit and  $t_{expected}$  is a parameter selected based on the time that a poll is likely to be in the given queue. While  $t_{expected}$  for each queue varies depending upon the data rate of the wire or optical fiber transmission line and the number of units, typical values are 50 mS for Poll Queue A, 500 mS for Poll Queue B, and 1000 mS for Poll Queue C.

After the calculation is made for the next item in each queue, the queue with the greatest urgency value is selected and a poll packet is formatted for the appropriate item in that queue and sent 272 to the corresponding station. Actual transmission of the packet is done by an interrupt service routine, which interrupts after each character is sent. After transmission of the EOT character, the central station disables the wire or optical fiber transmit interrupt, clears the communications receive interface, and enables receive inter-

rupts, to allow the interrupt routine to process incoming characters of the response. The Station Response Timer and the Station Response Timeout Flag are then cleared.

The module is then done and control passes to the start of FIG. 17.

FIG. 20 shows a flowchart of part of the communications software for the central station that processes the part of packets from the remote station that contain input data.

At point 5, a test is made 281 of whether input data is included in the unit subpacket. If not, control passes to point 6. If input data is included in the unit subpacket, control passes to step 287.

At point 6, a test is made 282 of whether a delete message sequence is included in the unit subpacket. If not, control passes directly to step 283. If yes, control passes to step 285.

The status of the unit is then set 283 to Receiving and Responding or Not Receiving but Responding, as appropriate.

A test is then made 284 of whether another unit subpacket is in the response. If yes, control passes to point 1 in FIG. 19. If not, control passes to point 4 in FIG. 19.

At step 285, a channel number is extracted from the unit subpacket, and that channel number used to delete the corresponding original message from the Message to Unit Queue and the Email Incoming Message Archive. The channel number is then deassigned from use by clearing the Assigned Bit in the Channel to Email Address Map for the corresponding channel.

A test is then made 286 of whether more messages should be deleted. If yes, control passes to step 285. If not, control passes to step 283.

At step 287, input data is extracted for one message. The message channel number indicates the message involved.

An Input Acknowledge packet containing the Input Packet Number is then sent 288 by placing it in Packet to Unit Queue C.

A test is then made 289 of the Input Packet Number by comparing it with the Last Packet Received number (which, unlike the case of the packet numbers used for output data, is the same for all priorities). The comparison is made modulo 128, with a received number considered greater than a last packet received number if it is between 1 and 63 above, modulo 128, the last packet received. (Thus, if the last packet received was 125, and the new packet just received had a number of 3, the new packet would be considered greater than the last packet received and thus not a duplicate). If the number of the packet just received is less than or equal to that of the last packet received, it is considered a duplicate and is ignored, with control passing to step 294. A received packet number is considered less than a last packet received number if it is between 1 and 63 below modulo 128, the last packet received. If the number of the packet just received is greater than that of the last packet received, the input packet is processed.

A test is then made 290 of whether the input data is a request for more data from an email message only part of which was sent to the communications unit. If yes, another message and packet is formatted and placed 295 in the Message to Unit Queue and the appropriate Packet to Unit Queue. Control then passes to step 294. If the input data is not a request for more data, the email address for the input data is then determined 291. If the input data is a response (either a response selected from those provided with the message, a preprogrammed response, or an original message sent as a response), the channel number is used to look up

the corresponding email address of the sender of the message in the Channel to Email Address Map. If the input data is an original message, it either contains a 7-bit code that is converted to an email address by looking it up in the Preprogrammed Email Address List, or it contains the actual email address.

If the message or response is in compressed form, it is expanded 292. FIG. 12 describes the format of different forms of compressed and uncompressed messages and responses. In the case of compressed responses the text is obtained by using a code to look up the expanded form of the response in an appropriate table, which replaces the codes before transmission of the message or response to its destination.

The resulting text after expansion and the addition of the electronic mail address of both the destination and originator is placed 293 in the Email Outgoing Message Queue. However, if the email address is another communications unit, the message is not placed in the Email Outgoing Message Queue but, instead, placed in the Email Incoming Message Archive and Email Incoming Message Queue.

A test is then made 294 of whether there is input data for more messages in the unit subpacket. If yes, control passes to point test 287. If no, control passes to point 6.

FIG. 21 shows a flowchart of the part of the communications software for the central station that selects and sends Data and other nonpoll packets to communications units via radio.

When started, the module first selects 301 the next packet to be sent. This is done as follows: There are seven queues: (Packet to Unit Queues A, B, C, D, E, F, and G) that hold packets, with an incoming message, such as that from a workstation via electronic mail, an incoming telephone call from a PABX system, or a message indicating that a FAX has come in, broken down into packets, with each packet placed in one of the Packet to Unit Queues depending upon the priority of the message. Packets that acknowledge input data from communication units (Input Acknowledge packets), or that acknowledge acknowledgements of Data packets (AckAck packets) are also placed in one of the queues (Queue C). A Data Confirm packet for each communications unit is entered in either Packet to Unit Queue F or G, depending upon the circumstances. At any given time, a Data Confirm packet for each unit is contained in either Queue F or Queue G.

To select the next packet to be sent, the oldest packet in each queue is retrieved (but ignoring packets marked as "Hold" or "Wait for Ack") and a calculation is made of the "urgency" of sending that packet, with urgency a measure of the extent to which not sending the data packet would result in allowing performance to lag behind what is expected for a particular queue.

The urgency calculation is made as follows:  $urgency = t_{actual} / t_{expected}$ , where  $t_{actual}$  is the actual time elapsed since the packet was entered into the queue, and  $t_{expected}$  is a parameter selected for each queue so as to allocate priority between the queues and that generally reflects the amount of time a packet is normally expected to be in each queue. Typical values are 50 mS for Queue A (Ring), 500 mS for Queue B (Urgent), 1 second for Queue C (Input Ack, and AckAck) 5 seconds for Queue D (High), 10 seconds for Queue E (Normal), 60 seconds for Queue F (Data Confirm, expected acknowledgement), and 600 seconds for Queue G (Data Confirm, no expected acknowledgement). These values can vary depending upon the data rate of the radio circuit chosen, the number of units in the system, and the average

level of traffic per unit. In making the calculation, only Data packets that have the "Hold" and "Wait for Ack" bits set to 0 are considered. The packet to be sent is that packet from the queue that has the highest urgency measure, except that in making this decision, urgency values for packets in Queues F and G are set to a maximum value if they exceed that value (to avoid these latter queues from taking too much capacity in peak load periods).

(In the alternative embodiment in which units are polled, an urgency calculation is also made for packets in the Unit Poll Queues A to C. These queues have a  $t_{expected}$  value of 100, 500, and 2000 mS, similar to that of the (Station) Poll Queues, with the Station ID field replaced by Unit ID fields. Unit IDs are moved in the Unit Poll Queues according to events in a manner similar to that of the entries in the (Station) Poll Queues so as to decrease response delay when traffic is sent. In addition, after the selection of a new packet, a test is made of whether the packet selected is a Unit Poll packet. If so, control is transferred immediately to point 1, causing the packet to be sent regardless of the status of the unit.)

After a packet has been selected, a test is made 302 of the status of the unit that the packet is to be sent to. There are five possible status states: Receiving and Responding, Not Receiving but Responding, Not Receiving or Responding (i.e., out of building), Receiving but not Responding (i.e., in a room with no infrared sensor) and Not Responding (not responding and unclear why). For purposes of this module, these are collapsed into two states, depending upon whether the unit is Receiving (Receiving and Responding, Receiving but Not Responding, or Not Responding) or Not Receiving (either Not Receiving but Responding or Not Receiving or Responding).

If the unit is Receiving, the packet is formatted and the first character is transmitted 303 to initiate the interrupt handler. If the packet is a Data packet, the Wait for Ack bit is set and the packet remains in the queue. Data Confirm packets also remain in the queue. If the packet is an Input Acknowledge or AckAck packet, the packet is removed immediately from the queue. If the packet just initiated is a Data packet and the next packet from the same message is available, it is placed 304 into the appropriate Packet to Unit Queue.

If the packet is a Data packet, the frequency of polling of stations likely to be near the communication unit is increased 305. This is done by looking up the unit in the Unit Status List and locating those stations that the unit has recently communicated with (the 10 stations as defined in the description of the Unit Status List data structure in FIG. 23). Each such station is moved to the highest priority polling queue, Poll Queue A, if it is not there already. The current time is also associated with the station entered into the queue and, if a station is already in Queue A, the time for that station is replaced with the current time. An entry is then made for the station and queue in the Time Event Queue, specifying a timeout time of the current time plus 90 seconds. The module is then done and control passes to test 211 in FIG. 17.

If the status of the unit is Not Receiving, a further test is made 306 of the priority of the packet. If it is Ring, a further test is made 307 of whether Caller ID information is included in the packet. If yes, Packet to Unit Queue D is searched 308 to see if there are any other packets that are exactly the same (i.e., with the same Caller ID information) as the selected packet, and in which the timing indicates they are simply additional rings of the same call. If so, the

selected packet is removed from the queue. If there are no such duplicate packets, the packet priority is changed to High and the packet removed from Packet to Unit Queue A and placed in Packet to Unit Queue D, and the Hold bit set so it will not be transmitted until a response is received from the unit (this provides a message to the user that a call was received, but not in real time). The module is then done.

If there is no Caller ID information, the Ring packet is removed 309 from the queue (resulting in the Ring being ignored) and the module is done.

If the packet priority resulting from test 306 is Other (Urgent, High or Normal), the packet is tagged 310 as Hold, and the module is done.

FIG. 22 shows a flowchart of the real-time clock interrupt module. The clock causes an interrupt every 1 mS, resulting in execution of the interrupt module. The Station Response Timer, a memory location which measures the time elapsed after a station poll packet has been sent, is first incremented 321. The resulting value is then tested 322. If it is 50 mS, the Station Response Timeout Flag is set 323, indicating that 50 mS has elapsed with no response from the given station. If not, control passes directly to step 324.

The Second clock, a memory location which provides a clock with one-second resolution, is then incremented 324. The result is then tested 325. If the result is 1000 mS, the Time of Day clock, a memory location which represents the absolute time and which has a resolution of 1 second, is then incremented 326, and the Time Event Flag is set 327, so that the main program will check the Time Event Queue. The Second clock is then cleared. The interrupt routine then dismisses.

FIGS. 23-31 show the data structures of the lists and queues used in the software for the microprocessor in the central communications station.

FIG. 23 shows the format of the Unit Status List. This list, for each unit, holds the unit ID code 330 (10 bits), the Unit Status 331 (3 bits), the last Packet Sequence Number (14 bits) for output data packets of 4 different priorities 332, 333, 334, and 335, the last Input Packet Number (7 bits) for input data packets 336, and information from up to 10 stations (with three shown, 337, 338, and 339) that have reported a response from the unit.

The Unit Status field 331 has five possible states: Receiving and Responding, Not Receiving but Responding, Receiving but Not Responding, Not Receiving or Responding, and Not Responding. Receiving and Responding means that the last response received from the unit reported a radio received signal reliability above a threshold value, and that the response was received within a timeout period (e.g., 120 seconds). Not Receiving but Responding means that the last response received from the unit reported a radio received signal reliability below the threshold value, and that the response was received within a timeout period. Not Receiving or Responding means that a response has not been received within the timeout period and that the last response was near an exit to the building (and the unit is presumed out of the building). Receiving but Not Responding means that a response has not been received within the timeout period and that the last response was near an area with no infrared sensors. Not Responding means that a response has not been received within the timeout period but there is no evidence the unit is in an unsensed area or out of the building.

The data structure for each station associated with a unit consists of the station ID 340, the time of last contact with that station 341 (14 bits), the reliability of the radio signal received by the unit 342 (7 bits), and the amplitude of the

infrared signal from the unit received by that station 343 (7 bits).

The stations are ordered such that the most recent contact with the station is listed first, the next most recent contact second, etc. However, only time differences greater than a threshold time are considered in performing this ordering: stations reporting time differences less than this are considered to have received the signal at the same time. This threshold takes into account the maximum time between successive repetitions of a signal from a unit and the difference in the time to poll different stations (e.g., 30 seconds). In addition, for those stations receiving the last signal at the same time, according to this rule, the stations are listed in order of strength of the received signal from the unit, with the strongest signal listed first, etc. A single station is only listed once, with the most recent contact (or strongest, if there is no time difference according to the above rule) listed.

FIG. 24 shows the Message to Unit Queue, which holds messages to be sent to units. For each message in the queue the data structure consists of the unit ID 351 and the text 352 of the message (with the first character in the message an STX and the second character the channel number assigned to the message). Each message in this queue is eventually broken down into packets and copied to one of the Data Packet Queues.

FIG. 25 shows the data structure of the Packet to Unit Queues, including Queues A, B, C, D, E, F, and G. These queues hold Data, Input Acknowledge, AckAck, and Confirm Data packets that are waiting to be transmitted to a unit. Each queue has the same structure (not all fields are necessarily used), which consists of a Unit ID code 361 (10 bits), a Hold bit 362, a Wait for Ack bit 363, a count of the number of transmissions attempted 364, a pointer to text 365 (to the Message to Unit Queue), and the Packet Sequence Number 366 (14 bits) entered when the packet is sent, and used to process the Acknowledgement when it is received.

The Hold bit is normally 0 but is set to 1 when the packet is to be held until a response has been received from the unit. The Wait for Ack bit is normally 0 but is set to 1 when the packet has been transmitted and the central station is waiting for it to be acknowledged.

Queue A is for Ring Data packets, Queue B for Urgent Data packets, Queue C for Input Acknowledge and AckAck packets, Queue D for High priority Data packets, Queue E for Normal priority Data packets, Queue F for Confirm Data packets for which data has been sent and an acknowledgement not received after an expected time, and Queue G for Confirm Data packets for which all acknowledgements have been received.

FIG. 26 shows the data structure of Poll Queues A, B, and C. Each queue contains a station ID code 371 and the time 372 the station was entered in that queue. Also associated with each queue is a single pointer for that queue 373 indicating which item in the queue is next in turn to be transmitted. The different queues, together with the poll selection algorithm, result in stations being polled at different frequencies, with stations in Queue A being polled at the highest frequency. Any station in the system is in one and only one queue at a given time. The time the station was entered in the queue is used to move the stations from a queue to a queue of lower priority after a given period of time.

(In the alternative embodiment in which units are polled, Unit Poll Queues A to C are used, with the same format as shown here for what would then be termed Station Poll Queues, except that the Station ID is replaced by a Unit ID.)

FIG. 27 shows the data structures for the Email Incoming Message Queue, the Email Incoming Message Archive, and the Email Outgoing Message Queue. The Email Incoming Message Queue contains electronic mail messages received through the Email Server that are waiting to be processed. Each item in the queue includes an email address 381 and message text 382. The Email Incoming Message Archive contains the complete message and holds it until the user deletes it at the communications unit. Each item in the message includes an email address 383, a pointer 384 to the next text byte that has not yet been copied to the Message to Unit Queue, and message text 385. The Email Outgoing Message Queue contains responses and messages waiting to be sent via the Email server to an email destination. Each item in the queue includes the destination email address 386, the originator's email address 387, and the text of the message 388.

FIG. 28 shows the data structures for the maps between email addresses and unit IDs and channels. The Email Address to Unit ID Map allows conversion of an Email Address 401 to the corresponding unit ID 402, while the Unit ID to Email Address Map allows conversion of the Unit ID 403 to the corresponding Email Address 404. The Channel to Email Address Map allows a channel number 405 sent by the communications unit to be translated to an email address 407 for a response to be sent, without the communications unit using an actual email address. An additional Assigned Bit field 406 indicates whether a particular channel is assigned or not, and another field 408 contains a pointer to the Email Incoming Message Archive, indicating the message involved. Note that channels 0 and 1 are not assigned in this way, being permanently reserved for original message transmissions (0) or communication with the PABX (1). The channel number is also included in a Delete message sent by the unit when the user has deleted a message, causing the message in the Email Incoming Message Archive to be deleted and the channel deassigned. Space is also provided to hold all information from a Delete operation in case the user reverses it with an Undelete.

FIG. 29 shows the data structure for the Input Data from Unit Queue, which holds packets received from a communications unit. This structure consists of the 10-bit ID of the unit the packet is from 409, the 7-bit channel number 410, the 7-bit Input Packet Number 411, and the input text 412.

FIG. 30 shows the data structures that hold the preprogrammed responses, messages, and email addresses. These include the Preprogrammed Response List (consisting, for each entry, of a 7-bit code 421 and the text for the response 422), the Preprogrammed Message List (consisting, for each entry, of a 7-bit code 423 and the text of the message 424), the Preprogrammed Email Address List (consisting, for each entry, of a 7-bit code 425 and an email address 426).

FIG. 31 shows the data structures for the Time Event Queue. This includes, for each entry, the absolute time of the future event 427, the type of event 428 (0 for Station Poll Queue Timeout, 1 for Unit Response Timeout), the Queue involved 429 (a particular Station Poll Queue or Packet to Unit Queue, and an ID field 430 containing either the Unit ID or station ID, as appropriate).

FIG. 32 shows the layout of the lamps, display and cursor, key, and thumbwheel on the front side of the remote unit.

The Ring/Urgent lamp 42 begins flashing at a rate of two flashes per second when a Ring packet is received, but then turns off after 4 flashes. The lamp also begins flashing at a rate of one flash every two seconds when an Urgent message is received, with the lamp turning to solid after 20 seconds.

If selected by the user, indicators will also be presented auditorily by means of the speaker 47. The Communications lamp 43 indicates the status of the communications circuits. If the lamp is turned on for any significant period of time, it indicates trouble. If a user has sent input data (i.e., responded to a message) but has not received an acknowledgement of it, the lamp turns solidly on. In addition, if Data (other than Ring) packets are found to be missing and the unit has not responded recently, the lamp will also be turned solidly on. In contrast, a momentary flicker of the lamp indicates that the circuit is working, with a single short flicker (150 mS) indicating a successful transmission of input data from the unit.

The action resulting from the key 48 depends on the location of the cursor 45 (represented as an arrow) relative to the text being displayed by the LCD 44. If the cursor is pointing to received message text, that message is deleted. (If the user deletes a message in error, selecting the "Undelete" command afterward will restore the message). If the cursor points to a response, that response is sent. If the cursor points to a command, that command is executed. If the cursor points to a preprogrammed message, that message is sent after prompting for an email address.

The thumbwheel 49 is rotated by the user's thumb to move the display window (i.e., that text actually displayed at any one time) up and down in the display memory. The "distance" covered by a particular degree of rotation depends upon the speed of rotation—rapid rotation results in more movement than does slower rotation.

FIG. 33 shows a variety of displays illustrating different situations and the interface presented in each situation. Display 451 indicates a typical message, with the example shown having the message aligned by the user with the thumbwheel so that the top line of the message is displayed at the top of the display field. The beginning and end of the message are indicated by right and left angle brackets, while responses that have been sent along with the message are displayed on each line surrounded by square brackets. The responses are chosen by the sender or software associated with origination of the message and are optional. If no responses are provided or none are appropriate, the user can choose from a set of preprogrammed responses or compose a response letter by letter. To respond to a message by choosing one of the responses received from a message, the user simply orients the display using the thumbwheel so that the desired response is to the right of the cursor, and presses the key. (Alternatively, instead or in addition to a cursor, the line the cursor is pointing to could display the characters in reverse, white on black, or with some similar distinctive form.) If one of the responses is "\*MORE\*", it indicates that additional data is available in the original message beyond that displayed. Selecting this response will cause transmission of this data to the communications unit. Just after the list of responses received with each message are two additional selections: "Go to responses" and "Go to messages". Pressing the key when the cursor points to either of these will cause the menu of preprogrammed responses or messages to be displayed, as appropriate.

Display 452 shows the top line that is displayed when a user moves the thumbwheel to the highest position in the Display Memory. (Another way to get there is by reversing the rotation of the thumbwheel twice in rapid succession.) The top two lines display status indicators, with one or more of the indicators shown displayed at a given time, as appropriate. If "High" is displayed it indicates that one or more of the unread messages has a priority of High. If "Voicemail" is displayed it indicates that the user has one or

more unheard voicemail messages. The user can either call the central voicemail system from a local telephone to listen to them or send a message asking that the messages be transcribed and sent to the communications unit. If "Fax" is displayed it indicates that a Fax message is waiting for the user. A message will also be received indicating which machine the Fax is at if there is more than one machine, and, optionally, a set of responses. If "Unread" is displayed, one or more messages have been received but not displayed by the user. Similarly, if "Print" is displayed it indicates that a print job is waiting for the user. If "Rcvr" is displayed it means that the received signal reliability has been less than 100% over the last N minutes, where N is typically 2. If "Trans" is displayed it means that a transmission from the unit has not been received by a remote station for the last N minutes, where N is typically 2. (The user can tell this from receipt of a Confirm Data packet). "OK" means that the signal reliability has been 100% since receipt of the last packet successfully transmitted to the specific unit, or since receipt of a Confirm Data indicating that all packets sent have been received. Below the status indicators are menu selections that cause the display to move to a particular point appropriate to a specific goal. This is simply a shortcut to reach these menus; the same effect can also be achieved by moving the thumbwheel to move the display window through the display memory.

Display 453 shows an example of a display where a Ring message arrival has interrupted the normal display. This display is set by the user to display for a fixed period of time (e.g., 30 seconds) and then disappear if no action by the user is taken within this period. The second line indicates the ID (extension number and name) of the calling party, if known. The two lines at the bottom indicate the current location of the communications unit (room number, extension, person or department associated with extension). Lines 3-5 have the following menu selections: The "Send to Voicemail" selection transfers the caller immediately to the voicemail system to take a message, while the "Transfer to Ext" selection will cause the incoming call to be routed to the indicated extension the communications unit is nearest to. The "Transfer to New Ext" selection will display a different menu, not shown, that allows a variety of other options for allowing the user to transfer to an extension other than the one the user is nearest, including arranging for the caller to be placed on hold until the transfer is made. These options, when chosen, will result in a new message from the Central Station displayed as a Ring interrupt on the LCD verifying the action, such as "Transfer to X5410 accepted."

Display 454 shows examples of preprogrammed responses that can be selected by the user and sent. The user orients the desired response so it is to the right of the cursor and presses the key. The last selection in this list ("Return to display") does not send a response but causes a redisplay of the last message to be displayed. The display will also redisplay the last message after any response is sent.

Display 455 shows examples of preprogrammed original messages that can be selected by the user, with each message enclosed in curly brackets. If this display is entered by selecting the "Go to messages" selection from a displayed message, the message will be sent as a response to that message. Otherwise, selection of the message (by pressing the key) will result in the display of a menu of electronic mail addresses. When that selection is made (again with the key) the message will be sent. One of the choices from the menu of electronic mail addresses allows the user to compose an email address letter by letter. If none of the canned messages is appropriate, the user selects the first item on the

list ("Go to compose message") which allows messages to be composed letter by letter.

Display 456 shows the list of individual characters and associated commands that can be selected to compose a message or email address. The composed material is displayed at the top of this part of the display memory, as shown in the example "This is text of message". Each letter is selected by pressing the key; the message is sent when Done is selected. "Clear" will erase the composed message and allow the user to start over. "Backspace" erases one letter.

Another display, not shown in a figure, allows the user to choose one or more commands to be executed that control operation of the remote communications unit. Some parameters for operation are set by the user using the thumbwheel and key; other parameters are set at the central communications station by a user addressing an email message (from a workstation) appropriately to a utility program that sets such parameters, with the email message containing the appropriate information.

The following are examples of commands that can be selected by the user at the unit:

"Beep if message rcvd" causes an auditory alarm if any message has been received.

"Beep if Urg msg" causes an auditory alarm if an Urgent message has been received.

"Flash if Ring" causes the Ring/Urg lamp to flash if a Ring message has been received.

"Beep if Ring" causes an auditory alarm if a Ring message has been received. "Menu if Ring" causes a display of the user's location and the menu (shown as 453) to be displayed when a ring message has been received to allow the user to transfer the call to a nearby extension.

"Locate" prompts for an email address and returns the last known location of the unit associated with that address.

"Set privacy Mode" turns off the "locate" command (which allows other users to determine the last known location of a user) for this user.

Other commands allow a user to define new responses to be added to the menu, new original messages, and new email addresses.

FIG. 34 shows a flowchart of the architecture of the software for the communications unit. Software is divided into five primary modules: (1) A module for processing packets that have been received from the central station; (2) A module for redisplaying message and menu text when the thumbwheel has been moved; (3) A module for processing presses of the key on the communications unit; (4) A module for transmitting a packet from the unit; and (5) A module that changes indicators such as the lamps and auditory alarm at specific times to provide appropriate flashing or beeping effects. In addition, clock and communications interrupt modules, not shown in the figure, provide support to the above software.

At the start of the module, a test is made 461 of whether a packet has been received by the unit from the central station via radio. Such a packet is detected by an interrupt service routine that processes incoming characters from the unit communications interface, which generates an interrupt for each received character. The interrupt handler looks for an SOH character, placing received characters into a buffer when an SOH has been detected. When an EOT character is received, the handler sets a flag indicating that a packet is ready to be processed.

If a packet has been received, the packet processing module 462 is called, resulting in different actions depend-



ing on whether the packet is a Data, Input Acknowledge, AckAck, or Confirm Data packet. Details are described in FIGS. 35-36 and the associated text. In general, packets are first error checked and the Unit ID compared with the internal ID of the unit and ignored (except for use in computing signal reliability statistics) if an error is detected or if the packet is for another unit. A Data packet is entered into memory, displayed, and an indicator alarm triggered, depending upon the packet priority and other factors. An Input Acknowledge packet causes an Input Data packet that the unit has been holding to be deleted, and an AckAck packet causes an Acknowledge packet that the unit has been holding to be deleted. Receipt of either causes the unit to transmit immediately if there is input data or acknowledgements remaining in the Input Data Queue or Packet Acknowledgement Queue after the above deletions. A Confirm Data packet, if there is missing received data, causes an indicator light to turn on to alert the user that the unit must be reoriented in direction or moved in position to allow data from the unit to be received.

If a packet has not been received, a test is made 463 of whether the thumbwheel has moved. An interrupt handler is used, with a clock tick every 0.83333 mS resulting (after a software divide-by-64 counter) in the thumbwheel position being checked every 53.33 mS and, if it has moved beyond a threshold allowable drift, a flag is set indicating that the window in the display memory should be moved, and a value for the amount of movement calculated. Details of the software for monitoring the thumbwheel and calculating the velocity and distance of movement of the thumbwheel and the resulting movement 464 of the display text, as well as the software for displaying the text, are contained in a copending application entitled "Control of Miniature Personal Digital Assistant Using Menu and thumbwheel."

If the thumbwheel has not moved, a test is made 465 of whether the key has been pressed. If yes, the appropriate action is taken 466, depending upon the location of the cursor in the displayed text and the context. This action may be to display different text, to execute a command that changes a local parameter (e.g., silencing the auditory alarm), or to execute a command or select a response that results in input data being transmitted to a remote station and then to the central station. If a response is selected a subpacket is formatted with an appropriate response sequence, including an Input Packet Number and a channel number indicating the destination address of the response. This sequence number is entered after incrementing the current Input Packet Number saved as a variable. The channel number is that found in the Display Memory associated with the message the response is to. If an original message is selected a subpacket is formatted in the same manner as described above. Either a channel number or the text of an email address is sent, depending upon whether the address is in the preprogrammed list or composed by the user. Any such input data is held in the Input Data Queue until the next transmission of an input packet. If input data has been generated, the Transmit Flag is set so that the packet will be transmitted immediately.

If a key has not been pressed, a test is made 467 of whether it is time for a transmission to be made from the unit. This is done by testing the state of the Transmit Flag. This flag is set (as indicated above) by a key press that results in input data that needs to be sent, the receipt of a non-Ring Data packet (resulting in an Ack that needs to be sent), by a timer that sets the flag at regular intervals, or by the receipt of an Input Ack or AckAck packet when data still remains to be sent. The average time between intervals

varies depending upon the receipt of data packets, the generation of input data, and the passage of time. There are three different intervals: A "short interval" results in transmissions being made at an interval from 10-25 seconds, with the exact time determined by adding 10 to a 4-bit random number. A "medium" interval is from 26-57 seconds, determined by adding 26 to a 5-bit random number. A "long" interval is from 58-121 seconds, determined by adding 58 to a 6-bit random number. The entry of input data results in transmission at short intervals, after the initial transmission which is done immediately. The receipt of a Data, Input Ack, or AckAck packet results in transmission at medium intervals (if the unit is not already transmitting at short intervals), after the initial transmission done immediately. After a unit has transmitted at short intervals for 5 minutes, it proceeds to transmit at medium intervals (if there has been no additional activity). After a unit has transmitted at medium intervals for 10 minutes, it proceeds to transmit at long intervals (if there has been no additional activity). Increasing the time between transmissions reduces drain on the battery in the unit, and also, together with random determination of the time between transmissions, reduces the likelihood of collisions between transmissions of different units in the same room. (In the alternative embodiment in which polling of units is done by radio, the unit does not transmit autonomously in the manner described above, but transmits only when a poll packet has been received.)

When a unit transmits, it selects the first sequence of input data from the Input Data Queue, and the first acknowledgement (or sequence, if continuous) from the Packet Acknowledgement Queue. This data is entered, along with the Unit ID, into the Unit Transmission Buffer, according to the format shown in FIG. 12, and the transmission of that buffer initiated 468. If Input Data is being transmitted the Communications State variable is set to 3 to indicate that the Input Data Timer is on, and the Input Data Timer is set to 20 seconds. The same clock interrupt handler that is used for periodically checking the position of the thumbwheel is also used, by means of software counters, to measure the time between transmission intervals as well as the time to change the visual and auditory indicator states, as described below.

(In the alternative embodiment in which polling is done by radio, the Transmit Flag is similarly set by input data entered, the receipt of a packet resulting in an Ack, or the receipt of an Input Ack or AckAck packet when data still remains to be sent. However, the Transmit Flag is not set by a timer in the unit in the absence of other activity, but is set by the receipt of a Poll packet by radio.)

If it is not time to transmit, a test is made 469 of whether it is time to change the indicators, including the Ring/Urgent lamp, the Communications lamp, or the auditory alarm. These operations 470 are performed by the clock interrupt handler, and details are shown in FIG. 37.

After each event has been processed, control is passed to the start of the module, with the sequence of tests ensuring that the highest priority tasks are performed first.

FIG. 35 shows a flowchart of the part of the software module in the communications unit devoted to processing incoming packets that have been received by the unit via radio.

A test is first made 481 of whether the Unit ID in the packet matches the internal ID of the unit and that the packet successfully passes an error check (by comparing the received cyclic redundancy check with one computed from the received data). If the unit ID does not match or if an error is found, the packet is not used. A calculation is then made 482 of the received signal reliability and the packet process-

ing module is done. If the reliability drops below a certain threshold, the "Rcvr" indicator is turned on, and "OK" is turned off if it was previously on. (Signal reliability is based on the proportion of packets received with a correct error check, regardless of the unit ID, as a function of the total number of packets received over a window of the last 120 seconds.) If there are no errors and the Unit ID is correct, a calculation is made **483** of the received signal reliability, and a test is then made **484** of the packet type.

If the packet is a Data packet, a test is made **485** of the status of the received packet, in the sense of how it should be processed, with this status determined largely by the sequence number of the packet number and its relationship with the last packet received for the given priority (referred to as the LPRGP). A packet is "Displayable" if the received packet has a sequence number exactly one above the LPRGP, or if it has a sequence number more than one above the LPRGP (implying one or more missed packets) and the packet is the first packet in a message. A packet is "Unassigned to Message" (meaning that it cannot be identified as belonging to a particular message) if it has a sequence number more than one above the LPRGP and the packet is not the first packet in a message. A packet is a "Retransmitted Missing Packet" if the sequence number is less than the LPRGP. If the packet has a sequence number exactly matching the LPRGP, it is a duplicate copy of a previously received packet and is ignored.

If the received packet is Displayable, it is placed **486** in the appropriate item in the Incomplete Message Packet Map (determined by searching the map for an item in which the sequence number fits, or creating a new item if the packet is the first in a message). The received packet number is then stored in the LPRGP as its new value, and control passed to point **1** in FIG. **36** so that the packet can be displayed or otherwise acted upon.

If the received packet is a Retransmitted Missing Packet, the Incomplete Message Packet Map is searched **487** to see if the packet unambiguously fits in a map item. If yes, the packet is entered **488** into that item (or a new item created if the packet is the first in a message). The Packets Unassigned to Messages List is then searched to see if there are packets that can be fit into the Incomplete Message Packet Map as a result of the most recent entry. If so, those packets are moved **489** to the map.

A test is then made **490** of whether there are new displayable packets in the map item just modified. If yes, control passes to point **1** in FIG. **36** so that they can be displayed. If not, the module is done.

If the received Retransmitted Missing Packet does not fit in the map item (test **487**), control passes to step **491**.

If the received packet is Unassigned to Message (resulting from the packet not having a previous packet received and not being a first packet in a message, and thus unable to be stored in the Incomplete Message Packet Map), the packet is entered **491** in the Packets Unassigned to Messages List, and the module is done.

If the packet type is Confirm Data, a test is made **492** of whether a packet is missing (as indicated by either packet sequence numbers for one or more priorities contained in the Confirm Data packet, not matching the unit's LPRGP, or noncontinuous packet numbers of received packets). If yes, and, in addition, a response has not been received for a threshold time period (30 seconds for Urgent packets, 120 seconds for others), the unit must successfully respond before that packet will be retransmitted, and thus the Communications lamp is turned solidly on **493** (by setting the Communications State to 1 and the Communications Lamp

Bit to 1) to indicate to the user that the unit should be moved in orientation or position so as to reestablish contact. The module is then done. If no packets are missing, the module is done immediately.

If the packet type is AckAck, the packet sequence number contained in the AckAck packet is removed **494** from the Packet Acknowledgement Queue. (If the packet sequence number is not in the list the packet is ignored as redundant.) Control then passes to step **495**.

If the packet received is an Input Acknowledge, the relevant packet is deleted **496** from the Input Data Queue. In addition, the Input Data State is set to 0, turning off the associated timer.

A test is then made **495** of whether there is input remaining—either input data or acknowledgements—in either the Packet Acknowledgement Queue or Input Data Queue, after the above deletions have been made. If yes, the Transmit Flag is set **496** so that the unit will transmit immediately.

If the Communications lamp is on, it is turned off **497**. If the lamp is not on, and only if an Input Ack was received, it is set to flicker for 150 mS (by setting the Communications State to 2 and the Communications Timer to 180), indicating in either case that the central station has received input data from the unit. The module is then done.

If the packet type is Input Acknowledge, the indicated input packet in the Input Data Queue is deleted **498**. In addition, the "OK" indicator is turned on if the Rcvr indicator is also off, and the "Trans" indicator turned off, if previously on. The Transmit Received Timer is also set to 0. Control is then passed to step **495**. If the indicated input packet is not in the Input Data Queue, the Input Acknowledge packet is ignored as redundant.

FIG. **36** shows a flowchart of the part of the software in the communications unit that processes displayable incoming Data packets that have been received.

At point **1**, a test is made **511** of the priority of the packet. If the priority is Ring (indicating an incoming telephone call), a further test is made **512** of whether this is the first packet in the message (indicated by an STX as the first character in the text field). If yes, a further test is made **513** of whether the entire message is contained in the first packet. If no, the message is not displayed at this time, and the module is done. If yes, a further test is made **514** of whether the message is a normal Ring message or a Ring Followup message, which is identified with an ASCII SUB character just after the channel number. If the message is a Ring Followup message, control is passed to step **519**. If the message is a normal Ring, the Ring State is set **515** to 8 to start the Ring/Urgent lamp flashing. The Auditory (or vibratory) Alarm State variable is also set to 8 to initiate it, if appropriate. A test is then made **516** of whether a Ring Interrupt Display is being displayed at the present time. If no, control passes to step **519**. If yes, a test is made **517** of whether the Ring message is from the same caller as the Ring Interrupt being displayed. If yes, the time that the present Ring Interrupt Display will be displayed is extended **518** (by setting the Ring Interrupt State to 1 and the Ring Interrupt Timer to be 30 seconds from the present time), and the module is done. If no, the Ring Interrupt is displayed **518** for the new call, and the module is done.

The Ring Interrupt Display will be maintained until either the user selects a response, 30 seconds have elapsed, a Ring followup message has been received, or a new Ring packet has been received for a different incoming call than that just displayed.

If the received packet is not the first packet in the message (test **512**), a further test is made **520** of whether previous

packets in the same message have been received. If yes, control passes to step 514. If no, the just-received packet is discarded 521. (If a Ring packet is lost, other packets in the same message are discarded, with the unit then waiting until the next Ring). The module is then done.

If the packet priority is Urgent, a further test is made 522 of whether the received packet is the first packet in the message. If yes, the Urgent State is set 523 to 22 to initiate the lamp blinking, and the Auditory Alarm State set to 8 if appropriate. In addition, the "Unread" message variable is set. Control then passes to step 524. If this is not the first packet in the message, control passes immediately to step 524.

The packet is then entered 524 into the display memory. If the message has a special character indicating that this announces that a Fax, Voicemail message, or Print job is available, the appropriate text is entered into the Display Memory to allow the appropriate indicator to be turned on. If the character just before the EOM is an ETB, indicating that there is additional data, a "\*MORE\*" response is provided to the user as an option. The packet number of the received packet (note that its first 2 bits consist of the packet priority) is then placed 525 in the Packet Acknowledgement Queue. The Transmit Flag is then set 526 so as to initiate transmission of the Unit Transmission Buffer immediately. The module is then done.

If the packet priority is High or Normal, a further test is made 527 of whether the received packet is the first in the message. If yes, the "High" and/or "Unread" message variable is set 528, as appropriate, and control passed to step 524. If the received packet is not the first in the message, control is passed immediately to step 524.

FIG. 37 shows a flowchart of the first part of the clock interrupt software for the microprocessor in the communications unit.

An interrupt occurs every 0.83333 mS, resulting in execution of the clock interrupt software. Once initiated, a test is first made 531 of whether the thumbwheel has moved beyond a certain threshold level. This is done by first checking a Thumbwheel Timer, which ranges from 0-63. If it is 0, the thumbwheel movement is calculated and the timer reset to 63. If not, the Thumbwheel Timer is decremented. This results in checking the thumbwheel position every 53.333 mS. If the thumbwheel moved, the Thumbwheel Movement Flag is set 532 so that the main program can respond to the movement.

The Transmit Timer, which holds the time remaining until the next transmission from the unit, is then decremented by an appropriate amount 533, and the result tested 534. If the result is 0, the Transmit Flag is set 535, indicating to the main program that a transmission should be initiated. (Steps associated with the Transmit Timer and Flag are left out in the alternative embodiment in which transmissions result from a received poll rather than an elapsed time interval).

A test is then made 536 of the Auditory Alarm State. This variable is 0 if the alarm has not been initiated, from 1 to 7 55 if it has, and 8 if the initiation has just been requested by the main program. Each of the states 1-7 represent time intervals in which the alarm is sounding or silent, with the intervals having the following lengths: Sounding for 50 mS, silent for 150 mS, sounding for 50 mS, silent for 750 mS, 60 sounding for 50 mS, silent for 150 mS, and sounding for 50 mS (for states 7 through 1, respectively). If the Auditory Alarm State variable is 8, control is passed to point 1. If it is 0, control passes to step 551. If it is from 1 to 7, the Auditory Alarm Timer is decremented 537 and the result 65 tested 538. If the result is 0 (end of alarm interval), control is passed to point 1.

At point 1, the Auditory Alarm State variable is decremented 539, the Auditory Alarm Timer is set to the maximum value for the new state (depending upon the time interval for that state), and the Sounding/Silent Flag is set to 1 or 0 depending upon whether the new state is sounding or silent, respectively. Control then passes to step 540. If the result of test 538 is greater than zero, indicating that time still remains in that alarm interval, and the Sounding/Silent Flag indicates Sounding, the state of the Auditory Output Bit 10 is toggled 540 (so as to create an on-off square wave with a period of 1.667 mS, resulting in an audio frequency of 600 hz plus harmonics). (Alternative embodiments might use a different sound pattern for different events, e.g., Ring, second ring for same caller, Urgent, etc., with a clock interrupt routine based on that shown here). Control then passes to step 551.

A test is then made 551 of the Ring Indicator State. If the Ring Indicator State variable is 8, control passes to point 2 to initiate a Ring indicator cycle.

At point 2, a test is made of whether the Urgent State is nonzero (indicating that an Urgent message is pending). If yes, the display indicating it is put on hold 552. This is done as follows: If the Urgent State is 1, indicating that the lamp is solidly on, the Urgent Hold State is set to 2, indicating a solid hold. If the Urgent State is 2 to 22, indicating that the lamp is in its blinking stage, the Urgent Hold State is set to 1, indicating a blinking hold. The Ring/Urgent Lamp Bit is then set to 0. Control then passes to step 555.

If the Ring Indicator State is 1-7, the Ring Indicator Timer is decremented 553, and the value after decrementing tested 554. If the result is greater than 0, control passes to point 4 in FIG. 38. If the result is 0, the Ring/Urgent Lamp Bit is toggled 555, the Ring Indicator State is decremented 556, and the Ring Timer is set 557 to 300, representing a value of 250 mS. Control then passes to point 4 in FIG. 38.

If the Ring Indicator State (test 551) is 0, ringing is not occurring, and control passes to point 3 in FIG. 38.

FIG. 38 shows a flowchart of the last part of the clock interrupt software for the microprocessor in the communications unit.

At point 3, a test is made 561 of whether a Ring Interrupt is pending, by testing the Ring Interrupt State. If it is 1 (yes, pending), the Ring Interrupt Timer is decremented 562. A test is then made 563 of the value of the Ring Interrupt 45 Timer. If the result is 0, the old display is restored 564 (from the appropriate location in the Display Memory), and the Ring Interrupt State set to 0. Control then passes to step 565. If the Ring Interrupt Timer is greater than 0, control passes immediately to step 565. If the result of the test 561 of the 50 Ring Interrupt State is 0, control also passes immediately to step 565.

A test is then made 565 of whether the Urgent indicator has been put on hold. (This is done by testing the Urgent Hold State, which is 2 if on hold from a solidly on lamp, 1 if on hold from a blinking lamp state, and 0 if not on hold.) If it is on hold, being solidly on, the Ring/Urgent Lamp Bit is turned on 566, the Urgent State is set 567 to 1, and control passes to point 4. If the Urgent indicator has been put on hold from a blinking state, the Urgent State is set 568 to 22, to reinitiate the blinking cycle from the beginning, and control passed to step 572.

If the Urgent indicator has not been put on hold, a test is made 569 of the Urgent State. If the Urgent State is 0 (no Urgent message pending) or 1 (lamp solidly on), control is passed to point 4. If the Urgent State is from 2 to 21 65 (representing intervals of on-off toggling every 1 second, resulting in a 1 sec on—1 sec off duty cycle every 2

seconds), the Urgent Timer is decremented **570** by 1, and a further test made **571** of the value of the Urgent Timer after such decrementing. If it is greater than 0, then the interval is not over, and control is passed to point **4**. If the Urgent Timer is 0, then the interval has expired, the Urgent State variable is decremented **573**, the Ring/Urgent Lamp Bit is toggled **574** (to turn the lamp on if previously off and vice-versa), and the Urgent Timer is set **575** to a value of 1200. (This represents 1000 mS, with each tick of the 0.83333 mS clock causing the timer to be decremented by 1). Control is then passed to point **4**.

If the Urgent State is 22 (Urgent just initiated), the Ring/Urgent Lamp Bit is set **572** to off (to make sure), and control passed to step **573**.

At point **4**, a test is made **585** of the Communications State. If it is set to 2 (flicker), indicating that a single flicker is being displayed, the Flicker Timer is decremented and, if the result is 0, the flicker has ended and the Communications State and Communications Lamp Bit are set **586** to 0. If the Communications State is set to 1 (input data sent), indicating that the Input Data Timer is on, the Timer is decremented **587** and the result tested **588**. If it is 0, the Communications Lamp Bit is set **589** to be solidly on. The module is then done and the interrupt is dismissed. If the Input Data Timer is greater than 0, the module is also done. If the Communications State (test **585**) is 0, the interrupt is dismissed immediately. Also included in the interrupt module (but not shown in the figure) is code for determining whether an Input Acknowledge packet (either an InputAck or UnitAck) has been received within a timeout period. Each clock interrupt causes a Transmit Received Timer to be incremented, and a test is made to see if the timer is greater than a timeout period, e.g., 180 seconds. If yes, the "Trans" indicator is displayed, and the "OK" indicator is turned off, if previously on. Similarly, a Signal Received Timer is incremented and used to determine whether a reliable signal has been received for at least the last 120 seconds. If not, the "Rcvr" indicator is turned on, and "OK" is turned off, if previously on.

FIGS. 39-43 show the data structures used in the software for the communications unit.

FIG. 39 shows the data structure for the Incomplete Message Packet Map. Each item in the Map contains information available about packets related to a specific message that is incomplete (i.e., all packets in the message—a first packet, a last packet, and all intervening packets—have not been received). An entry is made in the Map only if the first packet in the message has been received; otherwise, a packet is entered in the Packets Unassigned to Messages List. This implies that the first packet entered into the Map for each message is the first packet in that message. Each item in the Map consists of a priority for the message **601**, a "packet slot" (e.g., **602**) for each of the 8 packets that can potentially be in a message (0 through 7), and the sequence number for the first packet **603** (14 bits). Each packet slot, in turn, expanded as indicated by the arrow, consists of a Received Bit **604**, which is set to either 1 or 0 depending on whether the corresponding packet has been received or not, and an indirect pointer **605** to the Packet Text List, which contains the actual text received for each message. (The pointer references the address of a pointer in the Pointer List that contains the actual address in the Packet Text List). During error-free transmission the first packet and any number of succeeding packets may be received (Received Bit set to 1) while following packets have not been received (bit set to 0). If a packet has been received, however, and any packet slot preceding it (i.e., to the left in the diagram) has its Received

Bit set to 0, the associated packet is missing. Note that the channel number for each message is stored in the Packet Text List in the first packet received for that message, just after the STX character.

Also associated with the Map (but not shown in a figure) are four 14-bit counters, one for each packet priority, known as the LPRGP (Last Packet Received for Given Priority). This contains the packet sequence number for the last packet received for each priority.

FIG. 40 shows the data structure for the Packets Unassigned to Messages List, used in the software in the communications unit. This list holds those packets that have been received but have not been assigned to a message in the Incomplete Message Packet Map because there is no information, or the information is ambiguous, about their relationship to a particular message. The list consists of the following fields for each received packet: The priority **606**, the packet sequence number **607** (14 bits), and a pointer **608** to the Packet Text List.

FIG. 41 shows the data structures for the Packet Text List. This contains the text of packets being tracked by the Incomplete Message Packet Map and Packets Unassigned to Messages List. The upper part of the figure contains the text itself (**612**, **614**, and **616**), with packets placed in the Packet Text List in the order in which they are received, with each text packet beginning with an SOH (**611**, **613**, and **615**), and terminated **617** by either an SOH (indicating the start of a following packet) or an ETB (if no packet follows). The lower part of the figure contains a 16-bit pointer for each packet that indicates the address of the beginning of the packet. When a packet with N bytes is removed from the list the remaining text in the list is moved up by N bytes to take the place of the deleted packet and the pointers recalculated appropriately.

FIG. 42 shows the data structure for the Display Memory and the associated Display Window. The Display Memory **621** contains all of the information that can be displayed by the unit, in the order that a user might view it by rotating the thumbwheel. At any given time, only a narrow window (equal to the size of the display) is visible, with data transferred from the Display Memory to the Display Window **622** (a small buffer memory that is part of the LCD and which drives the display) whenever the thumbwheel is moved. The information contained in the Display Memory includes status indicators and the top-level menu (see the description of the unit interface), all text of the received messages, text of preprogrammed responses, text of preprogrammed messages, text and data for the Compose operation, text of electronic mail addresses, and text of commands.

Also shown is a Pointer List **623**, which contains 10-bit addresses pointing to the beginning of each of the significant areas of memory, in bytes. A pointer is included for each of 3 priorities of received messages (Urgent, High, and Normal) and for each of the areas shown in the display memory diagram **621**. (The Status Indicator area begins at address 0). Within a message priority, messages are stored in the Display Memory in the order of receipt of the first packet. Each message has been formatted at the central station to fit into specific lines (with a maximum of 20 character per line). Each message begins with (just after the STX character) a nondisplayed character that contains the channel number. Each physical line of text is terminated by a newline character. The message itself is terminated by an ASCII ETX (or a BEL if the full message has not been received). Each response included with the message is then terminated by an ETX. (If the response extends across more than one physical

line each line is terminated by a newline character). The last response is terminated by an EOM, with the EOM appearing at the end of the message even if there are no responses.

Preprogrammed Responses, Messages, Addresses, Commands, and the Compose Menu are coded similarly, with each physical line terminated by a newline character if the response extends across a single physical line, and each response terminated by an ETX. The Compose Menu also includes space for holding a response composed by the user.

FIG. 43 shows the data structures for the Input Data Queue, Packet Acknowledge Queue, and Unit Transmission Buffer.

Each entry in the Input Data Queue consists of the channel number for the message 631, a tag 632 indicating whether the input data is in the form of actual text or compressed text using a code, and a pointer (10 bits) to the actual input text or the actual code in the display memory.

Each entry in the Packet Acknowledgement Queue consists of the 14-bit Packet Sequence Number 634 for the packet being acknowledged.

The Unit Transmission Buffer consists of the current input packet being (repeatedly) transmitted, and consists of a packet header 635, unit ID 636, data 637 (either input data, an acknowledgement, or both), error check 638 and EOT 639. (An alternative embodiment would allow either input data or an acknowledgement, but not both, or, at the other extreme, multiple input packets and acknowledgement packets, with the transmission capacity and reliability in both directions and battery capacity determining the optimum design).

FIG. 44 shows a flowchart of the software for the micro-processor in the remote communications station.

At the start of the module, a test is made 641 of whether a packet has been received from a communications unit via infrared light (or ultrasound). This is done by checking the Packet Ready flag, a flag that is set by an interrupt service routine when a complete packet has been received. The interrupt service routine does this by first looking for an SOH and, when it is found, placing each received character in a buffer until an EOT is received, at which time the flag is set. The interrupt service routine, in addition to sampling the data, also measures the amplitude of the infrared signal received and, when an EOT is received, appends that measurement to the packet, in the form of a 7-bit character placed just before the ETX character, as indicated in FIG. 14.

If a packet has been received via infrared, an error check is computed 642 for the packet. If the error check is not successful, the packet is thrown away, the Packet Ready flag is cleared and control passes to the start of the module.

If the error check is successful, the packet (including signal amplitude measure) is placed 643 in the Received Packets Queue, with only one such packet for each unit being held. If a second packet is received from the same unit, the first is discarded and replaced by the more recent packet. Control then passes to the start of the module.

If a new infrared packet has not been received, a test is made 644 of whether a Poll has been received from the central station on the wire or optical communications circuit. If yes, a further test is made 645 of whether a packet has been received from one or more units via infrared (i.e., is a response packet available to be sent?) since the last Poll. If not, a NAK character is transmitted 646 to the central station via the communications circuit, and control is passed to the start of the module. If yes, the received packets for each unit are combined together (but leaving out the CRC character for each packet and adding a new CRC computed for the

combined packet being transmitted) and the packet transmission initiated 647 by placing it in a buffer and transmitting the first character. The combined packet also includes a field with the elapsed time since the last response was received from the unit, the strength of the signal when the packet was received, and a field with a measure of the reliability of the radio signal being received by the unit. Control is then passed to the start of the module. As each character completes transmission, an interrupt is generated and an interrupt handler obtains a new character from the buffer and transmits it. During this period incoming characters from the communications circuit are ignored. When the entire packet is transmitted, the interrupt handler resumes processing received characters from the circuit.

If a poll has not been received, control passes to the start of the module.

I claim:

1. A method for transmitting a message to an individual, comprising the steps of:

- originating said message addressed to said individual;
- transmitting the message to a central communications station;
- receiving and storing the message at said central communications station;
- creating a packet containing data from the message;
- transmitting said packet to a communications unit carried by the individual by the steps of:
  - (1) computing an error checking code and adding said code to the packet;
  - (2) adding a code to the packet identifying said communications unit;
  - (3) transmitting the packet by means of radio to the communications unit;
  - (4) receiving the packet at the communications unit;
  - (5) computing an error checking code;
  - (6) determining whether the packet has been correctly received by comparing the error checking code computed at the communications unit with the error checking code contained in the packet;
  - (7) constructing a packet at the communications unit comprising a code identifying the communications unit;
  - (8) adding a code identifying and thus acknowledging the received packet to said packet constructed at the communications unit, should the received packet contain a correct error checking code;
  - (9) transmitting the packet constructed at the communications unit from the communications unit via a medium selected from the group consisting of infrared light and ultrasonic sound to one or more of a plurality of remote stations, should the received packet contain a correct error checking code;
  - (10) receiving the packet constructed at the communications unit from the communications unit at a remote station and temporarily storing it;
  - (11) transmitting the packet constructed at the communications unit from said remote station, by means of a communications circuit via a medium selected from the group consisting of wire and optical fiber, to said central station;
- repeating the steps of creating the packet containing data from the message and transmitting the packet to a communications unit carried by the individual, until all data in the message has been transmitted from the central station to the communications unit;
- displaying said message to the individual.

39

2. The method of claim 1, wherein the step of transmitting the packet from the communications unit comprises the steps of:

transmitting a poll packet from the central station containing a code identifying the communications unit;  
receiving said poll packet at the communications unit;  
transmitting the packet from the communications unit.

3. The method of claim 1, wherein the step of transmitting the packet to the communications unit comprises the steps of:

determining a priority for each incoming message, with at least one level reserved for incoming telephone calls;  
assigning said priority to each packet the message is broken up into, with each packet containing a code indicating the priority;

allocating capacity of the radio communications channel such that messages with higher priority are given preference;

providing a humanly perceptible signal to the user at the communications unit when messages of particularly high priority have been received.

4. The method of claim 1, further comprising the steps of:  
transmitting a packet from the central station to each communications unit containing a sequence number for the last packet transmitted containing message text;  
receiving said packet containing said sequence number at the communications unit;

determining whether packets containing message text have been transmitted to the communications unit but not received by the unit;

providing a humanly perceptible signal to the user when it has been determined that a packet containing message text has not been received.

5. The method of claim 1, wherein the step of transmitting the packet from the remote communications station comprises the steps of:

transmitting a poll packet from the central station to the remote station;

receiving said poll packet at the remote station;

transmitting a packet from the remote station to the central station in response to said poll packet that contains those packets received from communication units since the receipt of the last poll packet at the remote station.

6. The method of claim 1, wherein a plurality of packets is transmitted from the central station to the communications unit before an acknowledgement is received for any of the packets.

7. The method of claim 6, wherein transmission of a packet from the central station comprises the steps of:

assigning a sequence number to the packet;

transmitting the packet to the communications unit with said sequence number included as part of the packet;

receiving the packet and checking the packet for errors at the communications unit;

transmitting a response from the communications unit containing an acknowledgement of the original packet, with the acknowledgement containing the sequence number of the original packet.

8. The method of claim 7, wherein transmission of the packet comprises the steps of:

transmitting a packet containing a sequence number to the communications unit;

waiting for a predetermined length of time for a response from the communications unit containing an acknowledgement with the corresponding sequence number;

40

removing the packet from a queue of packets to be transmitted should an acknowledgement be received;  
ignoring any further acknowledgements that are received for packets already removed from said queue of packets to be transmitted;

retransmitting the packet to the communications unit, should an acknowledgement with the proper sequence number not be received within the predetermined length of time.

9. The method of claim 8, wherein retransmission of an unacknowledged packet comprises the steps of:

determining the identity of the remote station last receiving a packet from the communications unit;

determining the time of receipt of said packet from the communications unit;

computing the probability that the unit is likely to receive the retransmitted packet if it is transmitted at the time the probability is computed at;

retransmitting the packet if the probability of receipt is above a certain threshold value.

10. The method of claim 1, wherein the step of transmitting the packet from the communications unit comprises the steps of:

transmitting the packet from the communications unit;

waiting for a specified period of time until the next transmission of the packet; in which the above steps are carried out repeatedly.

11. The method of claim 10, wherein the time delay before the next transmission of the packet is determined by the steps of:

determining the time since the last receipt of a packet with message text;

computing a time delay such that the frequency of repeated transmissions decreases as the time since the last receipt of a packet with message text increases.

12. The method of claim 10, wherein the step of transmitting the packet from the communications unit comprises the steps of:

transmitting the packet from the communications unit;

transmitting a packet from the central station to the communications unit acknowledging the acknowledgement of the original packet;

receiving said packet acknowledging the acknowledgement at the communications unit;

removing the sequence number of the acknowledged packet from the list of packets for which acknowledgements will be sent.

13. The method of claim 10, wherein the repeated transmission of the packet from the communications unit continues with the packet containing the unit identification code alone, should all received packets have been acknowledged.

14. A method for transmitting a message to an individual and returning a response to the originator of said message, comprising the steps of:

originating the message addressed to said individual;

transmitting the message to a central communications station;

receiving and storing the message at said central communications station;

creating a packet containing data from the message;

transmitting said packet to a communications unit carried by the individual by the steps of:

(1) computing an error checking code and adding said code to the packet;

41

- (2) adding a code to the packet identifying said communications unit;
- (3) transmitting the packet by means of radio to the communications unit;
- (4) receiving the packet at the communications unit;
- (5) computing an error checking code;
- (6) determining whether the packet has been correctly received by comparing the error checking code computed at the communications unit with the error checking code contained in the packet;
- (7) constructing a packet at the communications unit comprising a code identifying the communications unit;
- (8) adding a code identifying and thus acknowledging the received packet to said packet constructed at the communications unit, should the received packet contain a correct error checking code;
- (9) transmitting the packet constructed at the communications unit from the communications unit via a medium selected from the group consisting of infrared light and ultrasonic sound to one or more of a plurality of remote stations, should the received packet contain a correct error checking code;
- (10) receiving the packet from the communications unit at a remote station and temporarily storing it;
- (11) transmitting the packet originating from the communications unit from said remote station, by means of a communications circuit via a medium selected from the group consisting of wire and optical fiber, to said central station;
- repeating the steps of creating the packet containing data from the message and transmitting the packet to a communications unit carried by the individual, until all data in the message has been transmitted from the central station to the communications unit;
- displaying said message to the individual;
- accepting a response message by the individual at the communications unit in response to the received message;
- transmitting said response message from the communications unit by means of a medium selected from the group consisting of infrared light and ultrasonic sound to one or more of a plurality of remote stations;
- receiving the response message at a remote station and temporarily storing the response message;
- transmitting the response message from said remote station by means of a communications circuit via a medium selected from the group consisting of wire and optical fiber to the central station;
- receiving the response message at the central station;
- transmitting the response message from the central station to the originator of the message;
- receiving the response message by the originator of the message.
15. The method of claim 14, wherein the step of transmitting the response message comprises the steps of:
- transmitting the response message from the communications unit;
- waiting for a specified period of time until the next transmission; in which the above steps are carried out repeatedly.
16. The method of claim 14, wherein the step of transmitting a response message comprises the steps of:
- selecting said response message from a set of preprogrammed responses;

42

- encoding the response message as a numerical index to said set of preprogrammed responses rather than the text itself.
17. The method of claim 14, wherein transmitting the message and accepting a corresponding response message comprises the steps of:
- assigning a channel number to each message received at the central station;
- transmitting the message from the central station to the communications unit, with said channel number contained in the message;
- transmitting the response from the communications unit to the central station, with the channel number contained in the response;
- converting the channel number to an electronic mail address identifying the originator of the message;
- transmitting the response to the originator of the message by use of said electronic mail address.
18. The method of claim 14, further comprising the steps of:
- displaying a preprogrammed response to the user at the communications unit;
- editing the text of the response by the user at the communications unit;
- transmitting the modified response to the central station to update the corresponding list of preprogrammed responses stored at the central station.
19. The method of claim 14, wherein the step of transmitting the response message comprises the steps of:
- transmitting the response message from the communications unit, with the response message containing a sequence number identifying the particular response message;
- receiving the response message with corresponding sequence number at the remote station and forwarding it to the central station;
- receiving the response message with corresponding sequence number at the central station;
- transmitting a packet from the central station to the communications unit acknowledging the response message that contains the corresponding sequence number;
- ignoring further copies of the response message, as indicated by the sequence number, that may be received at the central station.
20. The method of claim 19, wherein the step of transmitting the response message comprises the steps of:
- transmitting the response message from the communications unit;
- waiting a specified period of time after transmission;
- providing a humanly perceptible signal to the user of the communications unit, should an acknowledgement of the response message fail to be received within said specified period of time.
21. The method of claim 14, further comprising the steps of:
- initiating a message requesting that a physical location be provided for the communications unit assigned to an individual;
- transmitting said message to the central station;
- determining the last known location of the communications unit assigned to said individual;
- transmitting a reply message to the initiator of the request containing the location of the communications unit.

43

22. The method of claim 21, wherein the step of transmitting the reply message to the initiator of the location request comprises the steps of:

determining whether the communications unit for which the request has been received has had a privacy mode selected by the user;

transmitting a message to the initiator of the location request indicating that said privacy mode has been selected, rather than indicating the location of the communications unit, should the privacy mode be selected.

23. The method of claim 14, further comprising the steps of:

transmitting part of the message stored at the central station to the communications unit;

displaying the part of the message received at the communications unit to the user, together with a response that, when chosen, requests additional text from the message;

choosing said response requesting additional text by the user;

transmitting a code representing the response together with identification of the message from the communications unit to a remote station and then to the central station;

transmitting additional text from the message from the central station to the communications unit;

displaying additional message text to the user.

24. The method of claim 23, further comprising the steps of:

the user performing an action at the communications unit communicating his or her intention of deleting a message;

44

deleting the part of said message received by the communications unit from its memory;

transmitting a code indicating a deletion request, together with identification of the message to be deleted, from the communications unit to the remote station and then to the central station;

deleting the message stored at the central station.

25. The method of claim 24, wherein the deletion of the message comprises the steps of:

deleting the part of the message received by the communications unit from its memory while saving the message in a temporary memory;

deleting the message stored at the central station, while saving the message in a temporary memory;

selecting a command by the user communicating the intention of reversing the delete action;

restoring the portion of the message received by the communications unit that had been deleted by obtaining the text from said temporary memory in the communications unit;

transmitting a code representing said reversing of the delete action to the remote station and then to the central station;

restoring the message in the central station that had been deleted to its original state by obtaining the message text from said temporary memory in the central station, the message text from said temporary memory in the central station.

\* \* \* \* \*



**IN THE UNITED STATES DISTRICT COURT  
FOR THE EASTERN DISTRICT OF TEXAS  
MARSHALL DIVISION**

MOBILE TELECOMMUNICATIONS  
TECHNOLOGIES, LLC,

v.

SPRINT NEXTEL CORP.

CASE NO. 2:12-CV-832-JRG-RSP

MOBILE TELECOMMUNICATIONS  
TECHNOLOGIES, LLC,

v.

APPLE INC.

CASE NO. 2:13-CV-258-JRG-RSP

MOBILE TELECOMMUNICATIONS  
TECHNOLOGIES, LLC,

v.

SAMSUNG TELECOMMUNICATIONS  
AMERICA, LLC.

CASE NO. 2:13-CV-259-JRG-RSP

**CLAIM CONSTRUCTION**  
**MEMORANDUM AND ORDER**

On March 7, 2014, the Court held a hearing to determine the proper construction of the disputed claim terms in United States Patents No. 5,590,403, 5,659,891, 5,754,946, 5,786,748, 5,809,428, 5,894,506, and 5,915,210. After considering the arguments made by the parties at the hearing and in the parties' claim construction briefing (Dkt. Nos. 107-2, 110, and 115),<sup>1</sup> the Court issues this Claim Construction Memorandum and Order.

<sup>1</sup> Citations to documents (such as the parties' briefs and exhibits) in this Claim Construction Memorandum and Order shall refer to the page numbers of the original documents rather than the page numbers assigned by the Court's electronic docket. Also, citations are to Civil Action No. 2:12-CV-832 unless otherwise indicated.

**Table of Contents**

**BACKGROUND** ..... 4

**LEGAL PRINCIPLES** ..... 4

**THE PARTIES’ STIPULATED TERMS**..... 6

**CONSTRUCTION OF DISPUTED TERMS**..... 7

**CONSTRUCTION OF DISPUTED TERMS IN U.S. PATENT NO. 5,590,403** ..... 8

    A. “transmitter[s]” and “base transmitter[s]” ..... 9

    B. “set[s] of transmitters” and “set of base transmitters” ..... 10

    C. “transmit . . . in simulcast,” “transmitted . . . in simulcast,” and “transmitting . . . in simulcast” ..... 15

**CONSTRUCTION OF DISPUTED TERMS IN U.S. PATENT NO. 5,659,891** ..... 16

    A. “paging carrier” and “paging system” ..... 16

**CONSTRUCTION OF DISPUTED TERMS IN U.S. PATENT NO. 5,754,946** ..... 19

    A. “switch actuatable,” “only upon actuation of the switch,” and “only upon receipt of the indication” ..... 20

    B. “a portion of the displayed message,” “a portion of a displayed message,” and “a portion of the message” ..... 21

    C. “means for retransmitting . . .” and “means for transmitting . . .” ..... 25

**CONSTRUCTION OF DISPUTED TERMS IN U.S. PATENT NO. 5,786,748** ..... 32

    A. “wireless page message,” “page number,” and “paging operations center” ..... 33

    B. “notifying recipient that the express mailing has not been delivered by the appointed time” ..... 36

**CONSTRUCTION OF DISPUTED TERMS IN U.S. PATENT NO. 5,809,428** ..... 38

    A. “network operation(s) center” ..... 38

    B. “probe message” ..... 43

    C. “means for determining whether an acknowledgment message is an acknowledgment to a data message or an acknowledgment to a probe message” ..... 48

    D. “means for generating, upon power restoration to the transmitter, a registration message if a probe message has been received while the transmitter was powered off, said registration message being transmitted by said transmitter” ..... 56

    E. “means for powering the transmitter on and off” ..... 61

    F. Additional Means-Plus-Function Terms ..... 61

**CONSTRUCTION OF DISPUTED TERMS IN U.S. PATENT NO. 5,894,506** ..... 64

    A. “canned message” and “canned multiple response options” ..... 65

B. "message code" and "response code" ..... 71  
**CONSTRUCTION OF DISPUTED TERMS IN U.S. PATENT NO. 5,915,210** ..... 74  
**CONCLUSION** ..... 74  
**APPENDIX A** ..... 76

## BACKGROUND

Plaintiff brings suit alleging infringement of United States Patents No. 5,590,403 (“the ‘403 Patent”), 5,659,891 (“the ‘891 Patent”), 5,754,946 (the ‘946 Patent”), 5,786,748 (“the ‘748 Patent”), 5,809,428 (“the ‘428 Patent”), 5,894,506 (“the ‘506 Patent”), and 5,915,210 (“the ‘210 Patent”) (collectively, the “patents-in-suit”). In general, the patents-in-suit relate to wireless messaging systems. The Court addresses each patent-in-suit separately herein.

Plaintiff asserts all of the patents-in-suit against Defendant Apple Inc. Plaintiff asserts only the ‘946 Patent, the ‘428 Patent, and the ‘506 Patent against Defendant Samsung Telecommunications America, LLC. For convenience, even as to patents that are asserted only against Defendant Apple Inc., the Court refers to the positions and arguments of “Defendants.”

## LEGAL PRINCIPLES

“It is a ‘bedrock principle’ of patent law that ‘the claims of a patent define the invention to which the patentee is entitled the right to exclude.’” *Phillips v. AWH Corp.*, 415 F.3d 1303, 1312 (Fed. Cir. 2005) (en banc) (quoting *Innova/Pure Water Inc. v. Safari Water Filtration Sys., Inc.*, 381 F.3d 1111, 1115 (Fed. Cir. 2004)). To determine the meaning of the claims, courts start by considering the intrinsic evidence. *See id.* at 1313; *see also C.R. Bard, Inc. v. U.S. Surgical Corp.*, 388 F.3d 858, 861 (Fed. Cir. 2004); *Bell Atl. Network Servs., Inc. v. Covad Commc’ns Group, Inc.*, 262 F.3d 1258, 1267 (Fed. Cir. 2001). The intrinsic evidence includes the claims themselves, the specification, and the prosecution history. *See Phillips*, 415 F.3d at 1314; *C.R. Bard*, 388 F.3d at 861. Courts give claim terms their ordinary and accustomed meaning as understood by one of ordinary skill in the art at the time of the invention in the context of the entire patent. *Phillips*, 415 F.3d at 1312-13; *accord Alloc, Inc. v. Int’l Trade Comm’n*, 342 F.3d 1361, 1368 (Fed. Cir. 2003).

The claims themselves provide substantial guidance in determining the meaning of particular claim terms. *Phillips*, 415 F.3d at 1314. First, a term's context in the asserted claim can be very instructive. *Id.* Other asserted or unasserted claims can aid in determining the claim's meaning because claim terms are typically used consistently throughout the patent. *Id.* Differences among the claim terms can also assist in understanding a term's meaning. *Id.* For example, when a dependent claim adds a limitation to an independent claim, it is presumed that the independent claim does not include the limitation. *Id.* at 1314-15.

"[C]laims 'must be read in view of the specification, of which they are a part.'" *Id.* at 1315 (quoting *Markman v. Westview Instruments, Inc.*, 52 F.3d 967, 979 (Fed. Cir. 1995) (en banc)). "[T]he specification 'is always highly relevant to the claim construction analysis. Usually, it is dispositive; it is the single best guide to the meaning of a disputed term.'" *Phillips*, 415 F.3d at 1315 (quoting *Vitronics Corp. v. Conceptronic, Inc.*, 90 F.3d 1576, 1582 (Fed. Cir. 1996)); accord *Teleflex, Inc. v. Ficosa N. Am. Corp.*, 299 F.3d 1313, 1325 (Fed. Cir. 2002). This is true because a patentee may define his own terms, give a claim term a different meaning than the term would otherwise possess, or disclaim or disavow the claim scope. *Phillips*, 415 F.3d at 1316. In these situations, the inventor's lexicography governs. *Id.* The specification may also resolve the meaning of ambiguous claim terms "where the ordinary and accustomed meaning of the words used in the claims lack sufficient clarity to permit the scope of the claim to be ascertained from the words alone." *Teleflex*, 299 F.3d at 1325. But, "[a]lthough the specification may aid the court in interpreting the meaning of disputed claim language, particular embodiments and examples appearing in the specification will not generally be read into the claims." *Comark Commc'ns, Inc. v. Harris Corp.*, 156 F.3d 1182, 1187 (Fed. Cir. 1998)

(quoting *Constant v. Advanced Micro-Devices, Inc.*, 848 F.2d 1560, 1571 (Fed. Cir. 1988)); accord *Phillips*, 415 F.3d at 1323.

The prosecution history is another tool to supply the proper context for claim construction because a patent applicant may also define a term in prosecuting the patent. *Home Diagnostics, Inc., v. Lifescan, Inc.*, 381 F.3d 1352, 1356 (Fed. Cir. 2004) (“As in the case of the specification, a patent applicant may define a term in prosecuting a patent.”). “[T]he prosecution history (or file wrapper) limits the interpretation of claims so as to exclude any interpretation that may have been disclaimed or disavowed during prosecution in order to obtain claim allowance.” *Standard Oil Co. v. Am. Cyanamid Co.*, 774 F.2d 448, 452 (Fed. Cir. 1985).

Although extrinsic evidence can be useful, it is “less significant than the intrinsic record in determining the legally operative meaning of claim language.” *Phillips*, 415 F.3d at 1317 (citations and internal quotation marks omitted). Technical dictionaries and treatises may help a court understand the underlying technology and the manner in which one skilled in the art might use claim terms, but technical dictionaries and treatises may provide definitions that are too broad or may not be indicative of how the term is used in the patent. *Id.* at 1318. Similarly, expert testimony may aid a court in understanding the underlying technology and determining the particular meaning of a term in the pertinent field, but an expert’s conclusory, unsupported assertions as to a term’s definition are entirely unhelpful to a court. *Id.* Generally, extrinsic evidence is “less reliable than the patent and its prosecution history in determining how to read claim terms.” *Id.*

#### **THE PARTIES’ STIPULATED TERMS**

The parties have reached agreement on constructions for certain terms, as stated in their

Joint Claim Construction and Prehearing Statement (Dkt. No. 72 at Ex. A), their briefing (*see, e.g.*, Dkt. No. 107 at App'x 1), their Joint Claim Construction Chart (Dkt. No. 116 at Ex. A), and at the March 7, 2014 hearing. The parties' agreements are set forth in Appendix A to this Claim Construction Memorandum and Order.

### **CONSTRUCTION OF DISPUTED TERMS**

As a threshold matter, Plaintiff submits: "For several terms drafted in means-plus-function format, Defendants dispute [Plaintiff's] inclusion of 'and equivalents' into the identified structure. It would be helpful to the jury to include this statutory phrase in each relevant construction. It is also commonplace to include this phrase—Markman Orders often acknowledge the statutory mandate of 35 U.S.C. §112." Dkt. No. 107-2 at 30. In accordance with this Court's standard practice, the Court includes "equivalents" as part of the corresponding structure for means-plus-function terms. *See* 35 U.S.C. § 112(f).

The Court herein addresses the disputed terms on a patent-by-patent basis. Terms that appear in more than one patent are noted accordingly but are not reproduced in multiple discussion sections below. The parties' briefing, as well as their arguments at the March 7, 2014 hearing, have indicated that the parties agree that disputed claim terms appearing in more than one patent should be given the same meaning for all such patents.

Finally, shortly before the start of the March 7, 2014 hearing, the Court provided the parties with preliminary constructions of the disputed terms with the aim of focusing the parties' arguments and facilitating discussion. Those preliminary constructions are set forth within the discussion of each term, below.

**CONSTRUCTION OF DISPUTED TERMS IN U.S. PATENT NO. 5,590,403**

The '403 Patent is titled "Method and System for Efficiently Providing Two Way Communication Between a Central Network and a Mobile Unit." The '403 Patent issued on December 31, 1996, and bears a filing date of November 12, 1992. In general, the '403 Patent relates to dynamic reassignment of transmitters from one zone to another. The Abstract of the '403 Patent states:

A two-way communication system for communication between a system network and a mobile unit. The system network includes a plurality of base transmitters and base receivers included in the network. The base transmitters are divided into zonal assignments and broadcast in simulcast using multi-carrier modulation techniques. The system network controls the base transmitters to broadcast in simulcast during both systemwide and zonal time intervals. The system network dynamically alters zone boundaries to maximize information throughput. The preferred mobile unit includes a noise detector circuit to prevent unwanted transmissions. The system network further provides an adaptive registration feature for mobile units which controls the registration operations by the mobile units to maximize information throughput.

The Court previously addressed the '403 Patent in *Mobile Telecommunications Technologies, LLC v. Clearwire Corp.*, No. 2:12-CV-308-JRG-RSP, Dkt. No. 72, 2013 WL 3339050, at \*2-\*3 (E.D. Tex. July 1, 2013) (referred to as the "*Clearwire Order*" or simply "*Clearwire*").



**A. “transmitter[s]” and “base transmitter[s]”**

Plaintiff’s Proposed Construction	Defendants’ Proposed Construction
No construction necessary; plain and ordinary meaning.	<p>“plain and ordinary meaning, with the understanding that the Court has rejected [Plaintiff’s] implication that transmitting multiple signals or outputs from a single structural unit can suffice as multiple transmitters”</p> <p><i>Alternatively:</i>                      “plain and ordinary meaning, with the understanding that transmitting multiple signals or outputs from a single structural unit cannot suffice as multiple transmitters”</p>

Dkt. No. 107-2 at 14; Dkt. No. 110 at 19; Dkt. No. 116, Ex. A at 23, 24 & 27. These terms appear in Claims 1, 10, and 11 of the ‘403 Patent. These terms also appear in Claim 5 of the ‘891 Patent.

In *Clearwire*, the Court construed the terms “transmitter” and “base transmitter” in the ‘403 Patent to have their plain and ordinary meaning. *Clearwire*, 2013 WL 3339050, at \*2. The Court also found:

Although the Court recognizes that claims 1 and 10 are method claims, a person of ordinary skill in the art would understand the terms “transmitter” and “base transmitter” to refer to a structural unit, and thus, the number of transmitters in a given system or method is dependent on structure, not function. . . . [T]he Court rejects [Plaintiff’s] implication that transmitting multiple signals or outputs from a single structural unit can suffice as multiple transmitters.

*Id.* (citing ‘403 Patent at 15:42-44). Nonetheless, the Court also “reject[ed] *Clearwire*’s proposition that a ‘transmitter’ must be spatially separated or geographically dispersed from other transmitters, because *Clearwire* has provided no evidence to support reading such a limitation into the claims.” *Id.* at \*3.

Shortly before the start of the March 7, 2014 hearing, the Court provided the parties with the following preliminary construction for these disputed terms: “Plain [meaning] ([e]xpressly adopt the *Clearwire* findings but do not provide them to the jury as part of a constr[uction].” At the March 7, 2014 hearing, all parties agreed to the Court adopting its preliminary construction, including as to the ‘210 Patent, which at the hearing the parties submitted also uses the term “transmitter[s].”

The Court therefore hereby construes “**transmitter[s]**” and “**base transmitter[s]**” to have their **plain meaning**. The Court further hereby adopts the above-quoted conclusions reached in *Clearwire* and orders that at trial the parties shall not present any arguments inconsistent with those conclusions.

**B. “set[s] of transmitters” and “set of base transmitters”**

Plaintiff’s Proposed Construction	Defendants’ Proposed Construction
No construction  <i>Alternatively:</i> “one or more [base] transmitters”	“set[s] of at least two [base] transmitters”

Dkt. No. 107-2 at 17; Dkt. No. 110 at 20; Dkt. No. 116, Ex. A at 23. These terms appear in Claims 1 and 10 of the ‘403 Patent.

*Clearwire* construed “set of transmitters” to mean “a set of at least two transmitters” and “set of base transmitters” to mean “a set of at least two base transmitters.” 2013 WL 3339050, at \*3. Shortly before the start of the March 7, 2014 hearing, the Court preliminarily proposed the same constructions that the Court reached in *Clearwire*.

(1) The Parties’ Positions

Plaintiff argues that Defendants’ proposal excludes the embodiment illustrated in Figures 6 and 7 that “us[es] only a single transmitter in each set.” Dkt. No. 107-2 at 17. Plaintiff

also argues that the disputed terms “are used according to their plain and ordinary meaning to indicate a logical grouping and not necessarily numerical limitation.” *Id.* at 18. Plaintiff cites a dictionary definition of “set” as “a number of things of the same kind that belong or are used together.” Dkt. No. 107, Ex. 6, *Merriam Webster’s Collegiate Dictionary* 1071 (10th ed. 1993). Plaintiff further submits that Claim 10 separately recites a requirement of at least two base transmitters by virtue of requiring simulcasting within each set of base transmitters. *Id.* at 19.

Defendants respond that they are proposing the *Clearwire* construction. Dkt. No. 110 at 20. Defendants also submit that the word “transmitters” is plural and that “there is not one example in the [‘]403 Patent where a ‘set of transmitters’ consists of a single transmitter.” *Id.* Defendants urge that Plaintiff misreads its relied-upon figures, namely Figures 6 and 7, which Defendants argue use the word “transmitters,” plural, and illustrate multiple transmitters. *Id.* Finally, Defendants argue that Plaintiff has improperly equated the words “set” and “zone.” *Id.* at 20-21.

Plaintiff replies: “A preferred embodiment of the ‘403 Patent discloses that a single transmitter meets the claim element ‘set of transmitters.’” Dkt. No. 115 at 6 (citing ‘403 Patent at 10:50-54). Plaintiff “maintains that the proper course most consistent with the intrinsic record may be to remove the numerosity requirement from the set of transmitters element, recognize that ‘set’ simply implies shared characteristics, and decline to construe the term which is non-technical and will not confuse the jury.” Dkt. No. 115 at 6.

## (2) Analysis

Claims 1 and 10 of the ‘403 Patent recite (emphasis added):

1. A method for information transmission by a plurality of transmitters to provide broad communication capability over a region of space, the information transmission occurring during at least both a first time period and a second time

period and *the plurality of transmitters being divided into at least a first and second set of transmitters*, the method comprising the steps of:

- (a) generating a system information signal which includes a plurality of blocks of information;
- (b) transmitting the system information signal to the plurality of transmitters;
- (c) *transmitting by the first and second sets of transmitters* a first block of information *in simulcast* during the first time period;
- (d) *transmitting by the first set of transmitters* a second block of information during the second time period; and
- (e) *transmitting by the second set of transmitters* a third block of information during the second time period.

\* \* \*

10. A method of communicating messages between a plurality of base transmitters and mobile receivers within a region of space divided into a plurality of zones with each zone having at least one base transmitter assigned thereto, the communication method comprising the steps of:

- (a) transmitting substantially simultaneously a first information signal and a second information signal to communicate messages to the mobile receivers, the first information signal being *transmitted in simulcast by a first set of base transmitters assigned to a first zone*, and the second information signal being *transmitted in simulcast by a second set of base transmitters assigned to a second zone*;
- (b) dynamically reassigning one or more of the base transmitters in the *first set of base transmitter [sic, transmitters]* assigned to the first zone to the *second set of base transmitters* assigned to the second zone as a function of the messages to be communicated in an area, thereby creating an updated *first set of base transmitters* and an updated *second set of base transmitters*; and
- (c) transmitting substantially simultaneously a third information signal and a fourth information signal, the third information signal being transmitted in simulcast by the updated *first set of base transmitters*, and the fourth information signal being transmitted in simulcast by the updated *second set of base transmitters* to communicate additional messages to said mobile receivers.

On one hand, the specification discloses an embodiment in which each “set” could include only one transmitter (one in each zone):

At this point, the exemplary communication system shown in FIG. 6 may transfer the message to the mobile unit during one of two time intervals. In the first time interval, *both base transmitter 612 and base transmitter 614 transmit data* via antenna 620 and antenna 622, respectively, *in simulcast* to be received by mobile unit 624, which corresponds to step 706 in FIG. 7. This first alternative may be

useful to deliver the message if, for example, the location of mobile unit 624 in *zone 1 or zone 2* is unknown and broad coverage is desired.

In the second time interval, base transmitter 614 transmits a block of information including the message data . . . and base transmitter 612 transmits another block of information, which corresponds to steps 708 and 710 of FIG. 7.

'403 Patent at 10:39-54 (emphasis added); *see id.* at Figs. 6 & 7. Likewise, whereas Claim 10 (quoted above) explicitly recites “simulcast by a first set of base transmitters assigned to a first zone” and “simulcast by a second set of base transmitters assigned to a second zone,” Claim 1 requires simulcast only by “the first *and* second sets of transmitters,” together. *See Phillips*, 415 F.3d at 1314 (“Because claim terms are normally used consistently throughout the patent, the usage of a term in one claim can often illuminate the meaning of the same term in other claims. Differences among claims can also be a useful guide in understanding the meaning of particular claim terms.”) (citations omitted).

On the other hand, above-quoted Claim 10 recites “dynamically reassigning one or more of the base transmitters,” plural.

In some cases, a plural term does not necessarily require two or more. For example:

In the phrase “[plurality of . . .] projections with recesses therebetween,” the use of “recesses” can be understood to mean a single recess where there are only two projections and more than one recess where there are three or more projections. Indeed, . . . if the patentees had wanted to require . . . more than one recess, it would have been natural to limit the claimed invention to an insert means with a “plurality of recesses.”

*Dayco Prods, Inc. v. Total Containment, Inc.*, 258 F.3d 1317, 1328 (Fed. Cir. 2001); *see Versa Corp. v. Ag-Bag Int'l Ltd.*, 392 F.3d 1325, 1330 (Fed. Cir. 2004) (as to the term “means . . . for creating air channels,” noting that “in context, the plural can describe a universe ranging from one to some higher number, rather than requiring more than one item”).

In general, however, the plural form of a noun refers to two or more, as found in *Markem-Imaje Corp. v. Zipher Ltd.*, 657 F.3d 1293, 1297 (Fed. Cir. 2011), and *Leggett & Platt, Inc. v. Hickory Springs Manufacturing Co.*, 285 F.3d 1353, 1357 (Fed. Cir. 2002). The Court addressed these and other relevant cases in *Calypso Wireless, Inc., et al. v. T-Mobile USA, Inc.*, No. 2:08-CV-441, Dkt. No. 281 at 27-32 (E.D. Tex. Dec. 3, 2012) (discussing *Flash Seats, LLC v. Paciolon, Inc.*, No. 07-575-JJF, 2010 WL 184080 (D. Del. Jan. 19, 2010), *aff'd*, 469 Fed. App'x 916 (Fed. Cir. 2012), *Every Penny Counts, Inc. v. Bank of Am. Corp.*, No. 2:07-CV-42-FTM-29SPC, 2008 WL 4491113 (M.D. Fla. Sept. 29, 2008), and *MOAEC, Inc. v. Pandora Media, Inc.*, No. 07-CV-654-BBC, 2008 WL 4500704 (W.D. Wis. Sept. 30, 2008)).

On balance, the use of the plural form of “transmitters” demonstrates that a “set of transmitters” requires two or more transmitters. *See, e.g., Leggett & Platt*, 285 F.3d at 1357 (“At the outset, the claim recites ‘support wires’ in the plural, thus requiring more than one welded ‘support wire.’”). The Court thus reaches the same conclusion here as in *Clearwire*.

The Court accordingly hereby construes the disputed terms as set forth in the following chart:

<u>Term</u>	<u>Construction</u>
“set[s] of transmitters”	“set[s] of at least two transmitters”
“set of base transmitters”	“a set of at least two base transmitters”

**C. “transmit . . . in simulcast,” “transmitted . . . in simulcast,” and “transmitting . . . in simulcast”**

Plaintiff’s Proposed Construction	Defendants’ Proposed Construction
“transmitting the same information at the same time”	“transmitting the same information at the same time, with the understanding that the Court has rejected [Plaintiff’s] argument that a single transmitter can operate in simulcast with itself by using multi-carrier modulation”  <i>Alternatively:</i> “transmitting the same information at the same time, with the understanding that a single transmitter cannot operate in simulcast with itself by using multi-carrier modulation”

Dkt. No. 107-2 at 20; Dkt. No. 110 at 23; Dkt. No. 116, Ex. A at 23-24, 25 & 27-28. These terms appear in Claims 1, 10, and 11 of the ‘403 Patent and Claims 1, 10, and 19 of the ‘210 Patent.

*Clearwire* construed these disputed terms in Claims 1 and 10 of the ‘403 Patent as meaning “transmitting the same information at the same time.” *Clearwire*, 2013 WL 3339050, at \*4. The Court also rejected any argument “that a single transmitter can operate in simulcast with itself by using multi-carrier modulation.” *Clearwire*, 2013 WL 3339050, at \*5.

Shortly before the start of the March 7, 2014 hearing, the Court provided the parties with the following preliminary construction for these disputed terms: “‘transmitting the same information at the same time’ ([e]xpressly adopt the *Clearwire* findings but do not provide them to the jury as part of a constr[uction].” At the March 7, 2014 hearing, all parties agreed to the Court adopting its preliminary construction.

The Court therefore hereby construes **“transmit . . . in simulcast,” “transmitted . . . in simulcast,” and “transmitting . . . in simulcast”** to mean **“transmitting the same information at the same time.”** The Court further hereby adopts the above-quoted conclusion reached in

*Clearwire* and orders that at trial the parties shall not present any arguments inconsistent with that conclusion.

**CONSTRUCTION OF DISPUTED TERMS IN U.S. PATENT NO. 5,659,891**

The ‘891 Patent is titled “Multicarrier Techniques in Bandlimited Channels.” The ‘891 Patent issued on August 19, 1997, and bears a filing date of June 7, 1995. In general, the ‘891 Patent relates to operating more than one carrier within a single channel. The Abstract of the ‘891 Patent states:

A method of multicarrier modulation using co-located transmitters to achieve higher transmission capacity for mobile paging and two-way digital communication in a manner consistent with FCC emission mask limits. Co-location of the transmitters obviates the need for stringent, symmetrical subchannel interference protection and provides for a wider range of operating parameters, including peak frequency deviation, bit rate, and carrier frequencies, to obtain optimal transmission performance.

**A. “paging carrier” and “paging system”**

<b>“paging carrier” (‘891 Patent, Claims 1 &amp; 3)</b>	
<b>Plaintiff’s Proposed Construction</b>	<b>Defendants’ Proposed Construction</b>
No construction necessary; plain and ordinary meaning.	“transmission signal modulated to carry information to one or more pagers”
<b>“paging system” (‘891 Patent, Claim 5)</b>	
<b>Plaintiff’s Proposed Construction</b>	<b>Defendants’ Proposed Construction</b>
“wireless message system” <sup>2</sup>	“system for communicating with one or more pagers”

Dkt. No. 107-2 at 12; Dkt. No. 110 at 24-25; Dkt. No. 116, Ex. A at 32 & 33.

<sup>2</sup> Plaintiff previously proposed: “No construction necessary; plain and ordinary meaning. In the alternative: ‘wireless message system.’” Dkt. No. 107-2 at 12.



Shortly before the start of the March 7, 2014 hearing, the Court provided the parties with the following preliminary constructions for these disputed terms: “paging carrier” means “transmission signal that can be modulated to carry paging information”; and “paging system” has its plain meaning. At the March 7, 2014 hearing, all parties agreed to the Court adopting its preliminary construction of “paging system.” Accordingly, the Court analyzes only the term “paging carrier” herein.

(1) The Parties’ Positions

Plaintiff argues that “[a] paging carrier is a carrier used to send a page message, not a carrier sent to a pager.” Dkt. No. 107-2 at 12. Plaintiff also argues that the preamble term “paging” is a non-limiting “descriptive name for the systems in which the methods recited by the Claims may be performed.” *Id.* at 12-13. Plaintiff further argues that “paging communications may be with telephones and other non-pager messaging devices, as the word ‘paging’ simply means notifying a person of a message.” *Id.* at 13.

Defendants respond that “the [‘]891 Patent is entirely directed to resolving perceived problems associated with bandlimited channels assigned by the FCC for mobile paging.” Dkt. No. 110 at 25. Defendants also cite an FCC definition of “paging service,” which is quoted below. *Id.* Defendants conclude that Plaintiff is attempting to remove the word “paging” from the claims. *Id.*

Plaintiff replies that by citing the FCC definition of “paging service,” Defendants seek to “require[] a specific technology/device and seek[] a definition from within that technology.” Dkt. No. 115 at 8. Plaintiff concludes that Defendants’ proposal “is thus impermissibly restrictive.” *Id.* at 9.

(2) Analysis

Claim 1 of the '891 Patent is representative and recites (emphasis added):

1. A method of operating a plurality of *paging carriers* in a single mask-defined, bandlimited channel comprising the step of transmitting said carriers from the same location with said carriers having center frequencies within said channel such that the frequency difference between the center frequency of the outer most of said carriers and the band edge of the mask defining said channel is more than half the frequency difference between the center frequencies of each adjacent carrier.

The Discussion of Related Art in the '891 Patent refers to "mobile paging":

The rising popularity of *mobile paging* services has resulted in increased competition for air time on the limited number of *radio-frequency channels* allocated by the Federal Communications Commission (FCC) for *mobile paging* use. As demand begins to approach and even exceed the capacity of assigned channels to handle transmission traffic, delays in service and deterioration of transmission quality are becoming a major concern to *mobile paging* users and providers.

The ability of *mobile paging* providers to successfully address the problem of transmission saturation is limited by the finite range of air space dedicated to *mobile paging* use. Channels assigned by the FCC to *radio paging* providers typically have narrow bandwidths (e.g. 25 kHz) and are subject to stringent emission mask limitations.

'891 Patent at 1:11-24 (emphasis added); *see id.* at 5:11-15 ("Thus, according to the present invention, increased transmission capacity is achieved by operating more than one *carrier* in a standard bandlimited channel assigned for *mobile paging* use, such as in the Narrowband Personal Communications Service or the Part 22 Service.") (emphasis added). The Abstract of the '891 Patent similarly refers to (emphasis added): "A method for multicarrier modulation using co-located transmitters to achieve higher transmission capacity for *mobile paging* and two-way digital communication in a manner consistent with FCC emission mask limits."

As to extrinsic evidence, Plaintiff has cited a technical dictionary definition of "paging" that states: "To give a message to someone who is somewhere, but where we don't know." Dkt.

No. 107, Ex. 8, *Newton's Telecom Dictionary* 582 (15th ed. 1999). Also, Defendants have cited a Federal Communications Commission (“FCC”) document that defines “paging service” as: “Transmission of coded radio signals for the purpose of activating specific *paggers*; such transmissions may include messages and/or sounds.” Dkt. No. 110, Ex. 18, 47 C.F.R § 22.99, p. 93 (10-1-1996 ed.) (emphasis added).

Because the word “carrier” in common parlance refers to a company rather than a signal, construction is appropriate to clarify that, as used in the patent, the term “paging carrier” refers to a signal. Such a reading is supported, for example, by the above-quoted disclosure of “operating more than one carrier in a standard bandlimited channel.” ‘891 Patent at 5:12-13.

The Court accordingly hereby construes the disputed terms as set forth in the following chart:

<u>Term</u>	<u>Construction</u>
<b>“paging carrier”</b>	<b>“transmission signal that can be modulated to carry paging information”</b>
<b>“paging system”</b>	<b>Plain meaning</b>

**CONSTRUCTION OF DISPUTED TERMS IN U.S. PATENT NO. 5,754,946**

The ‘946 Patent is titled “Nationwide Communication System.” The ‘946 Patent issued on May 19, 1998, and bears a filing date of September 21, 1993. The ‘946 Patent is a continuation-in-part of the ‘403 Patent. In general, the ‘946 Patent relates to avoiding retransmission of unneeded information. The Abstract of the ‘946 Patent states:

A two-way communication system for communication between a system network and a mobile unit. The system network includes a plurality of base transmitters and base receivers included in the network. The base transmitters are divided into zonal assignments and broadcast in simulcast using multi-carrier modulation techniques. The system network controls the base transmitters to broadcast in

simulcast during both systemwide and zonal time intervals. The system network dynamically alters zone boundaries to maximize information throughput. The system also uses a mobile unit which receives messages from the network and transmits messages to the network. The mobile unit includes a switch that allows a user to request the network to retransmit a received message that contains errors.

**A. “switch actuatable,” “only upon actuation of the switch,” and “only upon receipt of the indication”**

<b>“switch actuatable” (‘946 Patent, Claim 1)</b>	
<b>Plaintiff’s Proposed Construction</b>	<b>Defendants’ Proposed Construction</b>
No construction necessary; plain and ordinary meaning.	“a mechanical switch that requires user activation”
<b>“only upon actuation of the switch” (‘946 Patent, Claim 1)</b>	
<b>Plaintiff’s Proposed Construction</b>	<b>Defendants’ Proposed Construction</b>
No construction necessary; plain and ordinary meaning.	“only upon user actuation of the switch, as opposed to automatically”
<b>“only upon receipt of the indication” (‘946 Patent, Claim 8)</b>	
<b>Plaintiff’s Proposed Construction</b>	<b>Defendants’ Proposed Construction</b>
No construction necessary; plain and ordinary meaning.	“only upon receipt of the indication, as opposed to automatically”

Dkt. No. 107-2 at 8; Dkt. No. 110 at 14 & 16; Dkt. No. 116, Ex. A at 19 & 22.

Shortly before the start of the March 7, 2014 hearing, the Court provided the parties with the following preliminary constructions for these disputed terms: “switch actuatable” means “a switch that requires user activation”; “only upon actuation of the switch” and “only upon receipt of the indication” have their plain meaning. At the March 7, 2014 hearing, all parties agreed to the Court adopting its preliminary constructions.

The Court therefore hereby construes the disputed terms as set forth in the following chart:

<u>Term</u>	<u>Construction</u>
<b>“switch actuable”</b>	<b>“a switch that requires user activation”</b>
<b>“only upon actuation of the switch”</b>	<b>Plain meaning</b>
<b>“only upon receipt of the indication”</b>	<b>Plain meaning</b>

**B. “a portion of the displayed message,” “a portion of a displayed message,” and “a portion of the message”**

<b>“a portion of the displayed message” (‘946 Patent, Claims 1 &amp; 8)</b>	
<b>Plaintiff’s Proposed Construction</b>	<b>Defendants’ Proposed Construction</b>
“message data associated with a partially received message”	“less than the entire displayed message”
<b>“a portion of a displayed message” (‘946 Patent, Claim 7)</b>	
<b>Plaintiff’s Proposed Construction</b>	<b>Defendants’ Proposed Construction</b>
“message data associated with a partially received message”	“less than an entire displayed message”
<b>“a portion of the message” (‘946 Patent, Claim 1)</b>	
<b>Plaintiff’s Proposed Construction</b>	<b>Defendants’ Proposed Construction</b>
“message data associated with a partially received message”	“less than the entire message”

Dkt. No. 107-2 at 21; Dkt. No. 110 at 12; Dkt. No. 116, Ex. A at 19 & 20.

(1) The Parties' Positions

Plaintiff argues that “the Specification provides for transmission of the entire message” and that “[t]he erroneous part of the message could be the entire message.” Dkt. No. 107-2 at 21 (citing ‘946 Patent at 15:39-41 & 17:14-17).

Defendants respond that the specification and the prosecution history demonstrate that a “portion” of a message must be less than the entire message. Dkt. No. 110 at 12-13. Defendants explain, for example, that “if the mobile unit does not receive a complete message (albeit one containing errors), it never displays the message on the mobile unit to allow the user to request retransmission of the erroneous message portions.” *Id.* at 14 (citing ‘506 Patent at 9:26-28 & 17:10-14).

Plaintiff replies that the prosecution history cited by Defendants merely “states a capability of the invention.” Dkt. No. 115 at 3. Plaintiff also reiterates that “[t]he specification provides for retransmission of either the entire message, or parts thereof.” *Id.* at 4.

(2) Analysis

Claim 8 of the ‘946 Patent is representative and recites (emphasis added):

8. A method for receiving and transmitting messages at a mobile unit, comprising the steps of:
  - receiving at the mobile unit a radio frequency message;
  - displaying said message on the mobile unit;
  - receiving an *indication of a portion of the displayed message* for which a user desires retransmission;
  - transmitting, only upon receipt of the indication, a signal requesting *retransmission of said indicated portion of said message*;
  - receiving a retransmission of *said indicated portion*; and
  - displaying the received retransmission of *said indicated portion* on the mobile unit.

As a threshold matter, Plaintiff has not adequately explained or justified its proposal of “message data associated with a partially received message.” In particular, Plaintiff has not

identified any disclosure of displaying a partially received message. The below-quoted disclosure of retransmission of “partial messages containing errors” is not sufficiently clear in this regard. *See* ‘946 Patent at 17:10. Alternatively and in addition, Plaintiff’s proposal of the phrase “associated with” is vague and overbroad and would tend to confuse rather than clarify the scope of the claims.

As to the proper construction, the Summary of the Invention states:

To achieve the objects and in accordance with the purpose of the invention, as embodied and broadly described herein, the invention is directed to a mobile unit for transmitting and receiving radio frequency signals to and from a communications network comprising means for receiving radio frequency messages from the network, switch means for allowing a user to *request retransmission of at least parts of the message* from the communications network, and means for transmitting, upon actuation of the switch means, a signal to the communications network *requesting retransmission of the at least portions of the message*.

‘946 Patent at 5:8-18 (emphasis added). This disclosure of retransmission of “at least parts of the message” or “at least portions of the message” implies that the user could request retransmission of an entire message. Likewise, the specification discloses retransmission of entire messages:

If the mobile unit 624 does not completely receive the message, it can generate and broadcast a negative acknowledge signal. The negative acknowledge signal[] when delivered to the network operations center 600, indicates that *retransmission of the message* is necessary.

*Id.* at 9:26-30 (emphasis added).

The input switches 1516 also include a switch that allows the user to *request retransmission of a message corrupted by errors*.

*Id.* at 15:39-41 (emphasis added).

The request retransmission button 1622 *allows the user to request the base transmitters to retransmit received messages, or partial messages containing errors*. When the mobile unit receives a message containing errors, it displays the message on display 1606 with the *erroneous portions* highlighted (e.g.,

underlined, placed in brackets, or printed in reverse video). The user reads the message and determines whether the displayed message is acceptable. If not, the user can cause the system to *retransmit the message, or the erroneous portions*, by pressing request retransmission button 1622.

*Id.* at 17:8-17 (emphasis added). These disclosures of retransmitting an entire message could be read as weighing against Defendants’ contention that the disputed terms refer to less than an entire message.

A better reading, however, is that the patentee distinguished between retransmission of “the message” and retransmission of erroneous “portions.” *Id.* The specification thus demonstrates, particularly in the last of the above-quoted passages, that the term “portion” refers to something less than an entire message.

Moreover, during prosecution, the patentee stated that “the user can elect retransmission of only a *portion* of a message, rather than the *entire* message.” Dkt. No. 110, Ex. 13, 1/11/1996 Proposed Amendment Under 37 C.F.R §1.116 at 4 (emphasis added). The patentee thus reinforced during prosecution that “a portion of a message” is something less than the “entire message.”<sup>3</sup>

The Court accordingly hereby construes the disputed terms as set forth in the following chart:

<u>Term</u>	<u>Construction</u>
<b>“a portion of the displayed message”</b>	<b>“less than the entire displayed message”</b>

<sup>3</sup> At the March 7, 2014 hearing, Defendants emphasized additional prosecution history as purported evidence of the patentee’s disclaimer of interpreting the disputed terms to refer to some or all of a message. Plaintiff responded that Defendants’ arguments were not presented in Defendants’ responsive claim construction brief, and Plaintiff requested an opportunity to submit supplemental briefing. Because the Court construes the disputed terms without relying on the additional arguments presented by Defendants at the March 7, 2014 hearing, Plaintiff’s request for supplemental briefing is hereby denied as moot.



“a portion of a displayed message”	“less than an entire displayed message”
“a portion of the message”	“less than the entire message”

C. “means for retransmitting . . .” and “means for transmitting . . .”

<p><b>“means for retransmitting radio frequency signals containing the portion of the message to the mobile unit” (‘946 Patent, Claim 7)</b></p>	
<p><b>Plaintiff’s Proposed Construction</b></p>	<p><b>Defendants’ Proposed Construction</b></p>
<p>“[N]ot in 112/6<sup>4</sup> format. No Construction Necessary.” <i>Alternatively:</i></p> <p>Function: “retransmitting radio frequency signals containing the portion of the message to the mobile unit”</p> <p>Structure: “base transmitter 612; base transmitter 614; base transmitter 1300; or base transmitter 1400, and equivalents”</p>	<p>Function: “retransmitting radio frequency signals containing the portion of the message to the mobile unit only upon user actuation of the switch, as opposed to automatically”</p> <p>Structure: “base transmitter 612; base transmitter 614; base transmitter 1300; or base transmitter 1400”</p>
<p><b>“means for transmitting a first plurality of carrier signals within the desired frequency band, each of the first plurality of carrier signals representing a portion of the information signal substantially not represented by others of the first plurality of carrier signals” (‘210 Patent, Claim 19)</b></p> <p><b>“means for transmitting a second plurality of carrier signals in simulcast with the first plurality of carrier signals, each of the second plurality of carrier signals corresponding to and representing substantially the same information as a respective carrier signal of the first plurality of carrier signals” (‘210 Patent, Claim 19)</b></p>	
<p><b>Plaintiff’s Proposed Construction</b></p>	<p><b>Defendants’ Proposed Construction</b></p>
<p>“Not in 112/6 format: No Construction Necessary.” <i>Alternatively:</i></p> <p>Function for “means for transmitting a first plurality . . .” (<i>agreed</i>):</p>	<p>Functions: <i>Agreed</i></p> <p>Structure: “base transmitter 1300 including data input 1302, control logic 1304, modulators</p>

<sup>4</sup> 35 U.S.C. § 112, ¶ 6 (sometimes referred to as “§ 112(f”).

<p>“transmitting a first plurality of carrier signals within the desired frequency band, each of the first plurality of carrier signals representing a portion of the information signal substantially not represented by others of the first plurality of carrier signals”</p> <p>Function for “means for transmitting a second plurality . . .” (<i>agreed</i>):</p> <p>“transmitting a second plurality of carrier signals in simulcast with the first plurality of carrier signals, each of the second plurality of carrier signals corresponding to and representing substantially the same information as a respective carrier signal of the first plurality of carrier signals”</p> <p>Structure: “transmitter”</p>	<p>1306-1314, combiner 1316, power amplifier 1318, and an antenna 1320, as depicted in Fig. 13;</p> <p>OR</p> <p>base transmitter 1400 including data input 1402, control logic 1404, modulators 1406-1414, power amplifiers 1416-1424, combiner 1426, and an antenna 1428, as depicted in Fig. 14”</p>
--	---

Dkt. No. 107-2 at 26-27; Dkt. No. 110 at 15 & 21-22; Dkt. No. 116, Ex. A at 21-22 & 29-31.

Although the “means for transmitting . . .” terms appear in a different patent than the “means for retransmitting . . .” term, Plaintiff has presented them together. *See* Dkt. No. 107-2 at 26-29. The Court therefore addresses all of these terms here.

Shortly before the start of the March 7, 2014 hearing, the Court preliminarily proposed construing the “means for transmitting” terms in accordance with Defendants’ proposal. The Court also preliminarily proposed construing “means for retransmitting . . .” as a means-plus-function term with Plaintiff’s proposed function and the parties’ agreed-upon corresponding structure. At the March 7, 2014 hearing, all parties agreed to the Court adopting its preliminary construction for the “means for retransmitting . . .” term. The parties did not reach agreement as to the “means for transmitting . . .” terms. The following discussion therefore addresses only the “means for transmitting . . .” terms.

(1) The Parties' Positions

Plaintiff argues that “the §112, ¶ 6 presumption is defeated because the claim elements recite structure necessary to perform the agreed functions.” Dkt. No. 107-2 at 28. Plaintiff also argues that Defendants’ proposal for corresponding structure “is incorrect because it limits th[ese] element[s] to the preferred embodiments of Figures 13 or 14.” *Id.* at 29. At the March 7, 2014 hearing, Plaintiff presented the following alternative proposal for the corresponding structure: “a transmitter, including the transmitters disclosed in Figs 13 and 14, the transmitters as disclosed in the Specification at col. 5, ll. 26-40, and equivalents.” Plaintiff maintained that not all of the components in Figure 13 or Figure 14 are necessary, such as the “control logic” and the “combiner.”

Defendants respond that the “means for transmitting . . .” terms are means-plus-function terms because Claim 19 of the ‘210 Patent “does not recite any structure whatsoever for performing the claimed function.” Dkt. No. 110 at 22. Defendants urge that “[Plaintiff’s] alternative proposal that ‘transmitter’ is the only structure is insufficient because the recited function is not merely transmitting a signal.” *Id.*

Plaintiff replies by reiterating that the disputed terms are not means-plus-function terms. Dkt. No. 115 at 4 & 7. Alternatively, Plaintiff submits that “[t]he specification of the ‘403 Patent is replete with references to the terms ‘transmitter’ and ‘base transmitter’ and even includes an entire section entitled ‘[t]he Base Transmitter.’” *Id.* at 7 (citing ‘403 Patent at 8:41-45 & 15:41-16:23).

(2) Analysis

Plaintiff has failed to demonstrate that Claim 19 of the ‘210 Patent recites sufficient structure for the transmitting functions set forth in these disputed terms. Plaintiff has thus failed

to rebut the presumption that these disputed terms are means-plus-function terms. *See, e.g., Lighting World, Inc. v. Birchwood Lighting, Inc.*, 382 F.3d 1354, 1358 (Fed. Cir. 2004).

As to the parties' dispute regarding the corresponding structure, the specification of the '210 Patent discloses:

The base transmitters of the communication system, such as base transmitters 612 and 614 shown in FIG. 6, preferably utilize a multi-carrier modulation format as will now be described.

\* \* \*

#### D. The Base Transmitter

Each base transmitter unit, such as base transmitter 612 or 614 shown in FIG. 6, receives transmitter control data and message data transmitted from the satellite 606. FIG. 13 shows a first preferred embodiment of a base transmitter 1300 in accordance with the present invention. The base transmitter 1300 receives data from the satellite downlink connected to data input 1302 which provides this data to a control logic system 1304 to control the operation of the base transmitter unit. The control logic 1304 provides a control signal to a plurality of modulators 1306, 1308, 1310, 1312, and 1314. Modulator 1306 produces a carrier signal F1, modulator 1308 produces a carrier signal F2, modulator 1310 produces a carrier signal F3, modulator 1312 produces a carrier signal F4, and modulator 1314 produces a carrier signal Fn.

For example, the control logic may generate appropriate control signals to modulate the carrier signals in a MOK, BFSK, M'ary FSK, PFSK, or quadrature amplitude modulation scheme, as previously discussed. Each modulator then provides the modulated output signal to a combiner 1316 which combines each of the several modulated carrier frequencies into a single output signal.

The single signal is then applied to a power amplifier 1318 to amplify this signal to an appropriate level. The power amplifier 1318 may, for example, produce a nominal output signal of 350 watts to antenna 1320. In this embodiment, power amplifier [ ]1318 preferably has extremely linear characteristics to prevent formation of intermodulation products, and to insure that these intermodulation products do not cause signals to be generated at undesirable frequencies. Antenna 1320 broadcasts the desired signal from power amplifier 1318.

FIG. 14 shows a second preferred embodiment of a base transmitter unit. The second embodiment comprises a base transmitter 1400 which includes a satellite downlink connected to data input 1402, control logic 1404, and several modulators 1406, 1408, 1410, 1412, and 1414. Each modulator receives an

appropriate control signal from the control logic 1404, as previously discussed with respect to base transmitter 1300.

The output from each of modulators 1406, 1408, 1410, 1412, and 1414 in base transmitter 1400 is provided to respective power amplifiers 1416, 1418, 1420, 1422, and 1424 to provide an appropriate power output level for transmission, such as 350 watts aggregate.

The output from each of power amplifiers 1416, 1418, 1420, 1422, and 1424 is provided to combiner 1426 to combine the modulated carrier signals into a single output signal which is provided to antenna 1428 for broadcast.

'210 Patent at 13:3-5 & 15:49-16:31. For the corresponding structure, Defendants propose all of the structures illustrated in Figure 13 or, alternatively, all of the structures illustrated in Figure 14. Figures 13 and 14 of the '210 Patent are reproduced here:

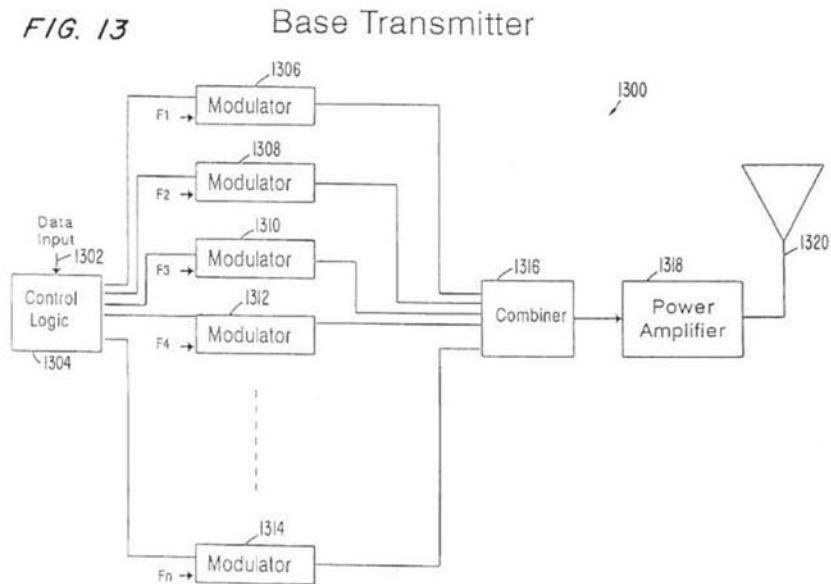
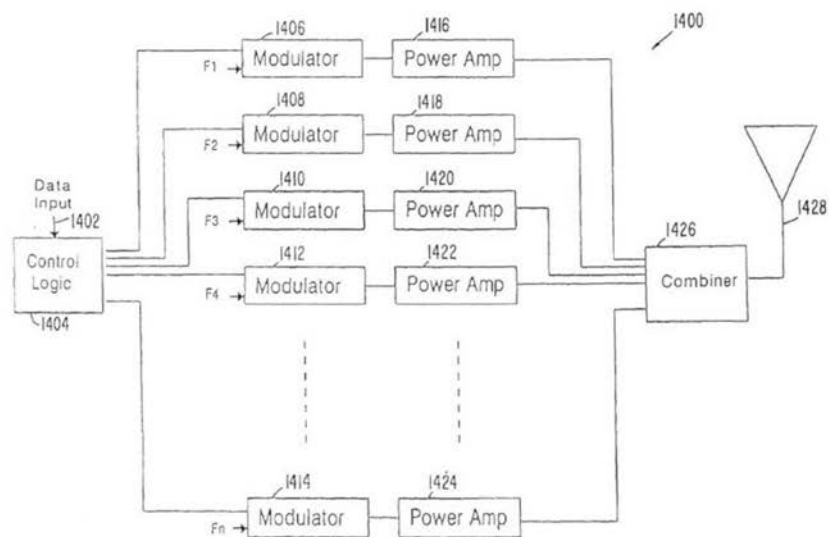


FIG. 14 Base Transmitter



As a general principle, “[a] court may not import into the claim features that are unnecessary to perform the claimed function. Features that do not perform the recited function do not constitute corresponding structure and thus do not serve as claim limitations.” See *Northrop Grumman Corp. v. Intel Corp.*, 325 F.3d 1346, 1352 (Fed. Cir. 2003) (citations omitted); see also *Golight, Inc. v. Wal-Mart Stores, Inc.*, 355 F.3d 1327, 1334-35 (Fed. Cir. 2004) (finding certain “structures . . . superfluous to our claim construction analysis because they are not required for performing the claimed function”); *Acromed Corp. v. Sofamor Danek Group Inc.*, 253 F.3d 1371, 1382 (Fed. Cir. 2001) (regarding a screw as corresponding structure, finding that “[t]o limit the body portion to a diameter at least as large as the crest diameter of the second externally threaded portion would be to impermissibly import into the claim limitation specific dimensions of a preferred embodiment that are unnecessary to perform the claimed function . . .”).

Nonetheless, Plaintiff’s proposal of a “transmitter” is insufficient for performing the functions recited by the “means for transmitting . . .” terms. See ‘210 Patent at 5:29-44 & 9:21-26. Instead, Figures 13 and 14 illustrate embodiments in which all of the illustrated components are necessary to constitute a “transmitter” and to accomplish the recited functions. Finally, these two embodiments illustrated by Figures 13 and 14 are alternatives and should therefore be included in the Court’s construction as alternative corresponding structures. See *Ishida Co., Ltd. v. Taylor*, 221 F.3d 1310, 1316 (Fed. Cir. 2000) (noting that a patent can “disclose[] alternative structures for accomplishing the claimed function”).

The Court accordingly hereby construes the disputed terms as set forth in the following chart:

<u>Term</u>	<u>Construction</u>
<p><b>“means for retransmitting radio frequency signals containing the portion of the message to the mobile unit”</b></p> <p><b>(‘946 Patent, Claim 7)</b></p>	<p>Function:  <b>“retransmitting radio frequency signals containing the portion of the message to the mobile unit”</b></p> <p>Structure:  <b>“base transmitter 612, base transmitter 614, base transmitter 1300, or base transmitter 1400; and equivalents thereof”</b></p>

<p><b>“means for transmitting a first plurality of carrier signals within the desired frequency band, each of the first plurality of carrier signals representing a portion of the information signal substantially not represented by others of the first plurality of carrier signals” (‘210 Patent, Claim 19)</b></p> <p><b>“means for transmitting a second plurality of carrier signals in simulcast with the first plurality of carrier signals, each of the second plurality of carrier signals corresponding to and representing substantially the same information as a respective carrier signal of the first plurality of carrier signals” (‘210 Patent, Claim 19)</b></p>	<p>Function for “means for transmitting a first plurality . . .” (agreed):</p> <p><b>“transmitting a first plurality of carrier signals within the desired frequency band, each of the first plurality of carrier signals representing a portion of the information signal substantially not represented by others of the first plurality of carrier signals”</b></p> <p>Function for “means for transmitting a second plurality . . .” (agreed):</p> <p><b>“transmitting a second plurality of carrier signals in simulcast with the first plurality of carrier signals, each of the second plurality of carrier signals corresponding to and representing substantially the same information as a respective carrier signal of the first plurality of carrier signals”</b></p> <p>Structure:</p> <p><b>“base transmitter 1300 including data input 1302, control logic 1304, modulators 1306-1314, combiner 1316, power amplifier 1318, and an antenna 1320, as depicted in Figure 13; and equivalents thereof”; or</b></p> <p><b>“base transmitter 1400 including data input 1402, control logic 1404, modulators 1406-1414, power amplifiers 1416-1424, combiner 1426, and an antenna 1428, as depicted in Figure 14; and equivalents thereof”</b></p>
---	--

**CONSTRUCTION OF DISPUTED TERMS IN U.S. PATENT NO. 5,786,748**

The ‘748 Patent is titled “Method and Apparatus for Giving Notification of Express Mail Delivery.” The ‘748 Patent issued on July 28, 1998, and bears a filing date of February 28, 1997. The ‘748 Patent claims priority benefit of a provisional application filed February 29, 1996. The Abstract of the ‘748 Patent states:



To provide prompt notification of delivery of an express mailing to the addressee thereof, the page number of a person to be notified upon delivery of the express mailing is communicated to an express mail tracking network and to an operations center of a wireless paging service. When the paging operations center learns of the delivery, either from the tracking network or from a page message transmitted from the delivery site, the person to be notified is paged by the operations center.

**A. “wireless page message,” “page number,” and “paging operations center”**

<b>“wireless page message” (‘748 Patent, Claim 1)</b>	
<b>Plaintiff’s Proposed Construction</b>	<b>Defendants’ Proposed Construction</b>
No construction necessary; plain and ordinary meaning.	“message sent to or from a pager in a paging network”
<b>“page number” (‘748 Patent, Claim 1)</b>	
<b>Plaintiff’s Proposed Construction</b>	<b>Defendants’ Proposed Construction</b>
No construction necessary; plain and ordinary meaning.	“unique number assigned to a pager in a paging network”
<b>“paging operations center” (‘748 Patent, Claim 1)</b>	
<b>Plaintiff’s Proposed Construction</b>	<b>Defendants’ Proposed Construction</b>
No construction necessary; plain and ordinary meaning.	“center operated by a paging service for sending and receiving messages to or from a pager in a paging network”

Dkt. No. 107-2 at 12; Dkt. No. 110 at 24; Dkt. No. 116, Ex. A at 35 & 36.

Shortly before the start of the March 7, 2014 hearing, the Court provided the parties with the following preliminary constructions for these disputed terms: “wireless page message” means “message sent to or from a wireless device in a paging network”; “page number” means “number assigned to a wireless device in a paging network;” and “paging operations center” means “center operable for sending messages to a wireless device in a paging network.”

(1) The Parties' Positions

Plaintiff presents the same arguments for these terms as for the terms “paging carrier” and “paging system” in the ‘891 Patent, above. See Dkt. No. 107-2 at 12-14.

Defendants respond that “SMS and email were well-known technologies by 1997, when the patent application was filed, but the specification only describes messages sent to a recipient’s *pager*.” Dkt. No. 110 at 24 (citing ‘748 Patent at 2:45-51, 2:60-64, 3:38-41 & Fig. 2).

Plaintiff replies: “The failure to reference the existence of an alternative technology is not indicative of an intention to exclude it. A ‘page message’ is simply a data message (traditional page, SMS, e-mail, etc.) sent to a receiving unit called a pager. There is no evidence foreclosing other message types. [Defendants are] attempting to impose limitations from a single preferred embodiment.” Dkt. No. 115 at 8.

(2) Analysis

Claim 1 of the ‘748 Patent recites (emphasis added):

1. A method for providing notification of an express mail delivery to an addressee thereof, comprising the steps of:
  - sending to an express mail tracking service an ID number assigned to an express mailing and a *page number* of a delivery notification recipient;
  - relaying the ID, *page number*, and an appointed time to a *paging operations center*;
  - providing a first indication to the *paging operations center* that the express mailing has been delivered to the addressee;
  - providing a second indication to the *paging operations center* that the express mailing has not been delivered to the addressee by the appointed time;
  - transmitting, responsive to the first indication, a *wireless page message* to the recipient as notification of the express mailing delivery; and
  - transmitting, responsive to the second indication, a *wireless page message* to the recipient notifying recipient that the express mailing has not been delivered by the appointed time.

On one hand, Defendants’ proposed constructions use the word “pager,” thereby arguably merely rephrasing the disputed terms because Defendants have not proposed an interpretation for

“pager.” Nonetheless, Defendants’ proposed constructions appropriately clarify, for example, that “page” and “page number” do not refer to something like a page of a document or a hardware serial number of a pager.

As to Defendants’ proposal for “page number,” however, Defendants’ have not justified requiring a “unique” number. Defendants’ proposal in that regard is rejected. Likewise, Defendants have failed to support their proposal that a “paging operations center” must be operable for both sending messages to a pager *and* receiving messages from a pager. In other words, Defendants have not justified importing a two-way paging limitation. Instead, Claim 1 and the context of the specification only require that the paging operations center be operable for sending messages *to* a pager. Finally, Defendants’ proposal that a “paging operations center” must be “operated by a paging service” is unclear and unsupported and would tend to confuse rather than clarify the scope of the claim.

The Court therefore hereby construes the disputed terms as set forth in the following chart:

<u>Term</u>	<u>Construction</u>
<b>“wireless page message”</b>	<b>“message sent to or from a wireless device in a paging network”</b>
<b>“page number”</b>	<b>“number assigned to a wireless device in a paging network”</b>
<b>“paging operations center”</b>	<b>“center operable for sending messages to a wireless device in a paging network”</b>

**B. “notifying recipient that the express mailing has not been delivered by the appointed time”**

Plaintiff’s Proposed Construction	Defendants’ Proposed Construction
No construction necessary; plain and ordinary meaning.	“plain meaning, which is that the notification is sent after the appointed time for delivery has passed and the express mailing was not delivered by that time” <sup>5</sup>

Dkt. No. 107-2 at 14; Dkt. No. 110 at 23; Dkt. No. 116, Ex. A at 36. This term appears in Claim 1 of the ‘748 Patent.

Shortly before the start of the March 7, 2014 hearing, the Court preliminarily proposed that this disputed term be construed to have its plain meaning.

(1) The Parties’ Positions

Plaintiff’s argument in its opening brief, in full, is: “The meaning is clear from the term itself, which states ‘notifying recipient that the express mailing has not been delivered by the appointed time.’” Dkt. No. 107-2 at 14.

Defendants respond that this disputed term should be given “its plain meaning, which is that the notification is sent *after* the appointed time for delivery has passed and the express mailing was *not* delivered by that time.” Dkt. No. 110 at 23. Defendants submit that “[Plaintiff’s] infringement contentions assert that notifications sent *prior* to an appointed delivery time (for purposes of rescheduling the delivery) satisfy this claim limitation.” *Id.* at 24.

Plaintiff’s argument in its reply brief, in full, is: “[Defendants] attempt[] to alter the plain and ordinary meaning to only include messages sent ‘after the appointed time for delivery has passed and the express mailing was not delivered by that time.’ [Defendants’] proposed

---

<sup>5</sup> Defendants previously proposed: “plain meaning, *with the understanding* that the notification is sent after the appointed time for delivery has passed and the express mailing was not delivered by that time.” Dkt. No. 72, Ex. B at 8 (emphasis added).

construction seeks to add a redundant and confusing requirement to a term that jurors would easily understand, in violation of established claim construction law.” Dkt. No. 115 at 8.

(2) Analysis

Claim 1 of the ‘748 Patent recites (emphasis added):

1. A method for providing notification of an express mail delivery to an addressee thereof, comprising the steps of:
  - sending to an express mail tracking service an ID number assigned to an express mailing and a page number of a delivery notification recipient;
  - relaying the ID, page number, and *an appointed time* to a paging operations center;
  - providing a first indication to the paging operations center that the express mailing has been delivered to the addressee;
  - providing a second indication to the paging operations center that the express mailing has not been delivered to the addressee by the appointed time;*
  - transmitting, responsive to the first indication, a wireless page message to the recipient as notification of the express mailing delivery; and
  - transmitting, responsive to the second indication, a wireless page message to the recipient *notifying recipient that the express mailing has not been delivered by the appointed time.*

Defendants’ proposed construction, which merely restates the disputed term, is hereby rejected as unnecessary in light of the context set forth in the claim, quoted above. Instead, Defendants’ argument regarding Plaintiff’s infringement contentions raises factual questions of infringement rather than legal questions of claim construction. *See PPG Indus. v. Guardian Indus. Corp.*, 156 F.3d 1351, 1355 (Fed. Cir. 1998) (noting that “the task of determining whether the construed claim reads on the accused product is for the finder of fact”).

No further construction is required. *See U.S. Surgical Corp. v. Ethicon, Inc.*, 103 F.3d 1554, 1568 (Fed. Cir. 1997) (“Claim construction is a matter of resolution of disputed meanings and technical scope, to clarify and when necessary to explain what the patentee covered by the claims, for use in the determination of infringement. It is not an obligatory exercise in redundancy.”); *see also O2 Micro Int’l Ltd. v. Beyond Innovation Tech. Co.*, 521 F.3d 1351,

1362 (Fed. Cir. 2008) (“[D]istrict courts are not (and should not be) required to construe every limitation present in a patent’s asserted claims.”); *Finjan, Inc. v. Secure Computing Corp.*, 626 F.3d 1197, 1207 (Fed. Cir. 2010) (“Unlike *O2 Micro*, where the court failed to resolve the parties’ quarrel, the district court rejected Defendants’ construction.”).

The Court therefore hereby construes **“notifying recipient that the express mailing has not been delivered by the appointed time”** to have its **plain meaning**.

**CONSTRUCTION OF DISPUTED TERMS IN U.S. PATENT NO. 5,809,428**

The ‘428 Patent is titled “Method and Device for Processing Undelivered Data Messages in a Two-Way Wireless Communications System.” The ‘428 Patent issued on September 15, 1998, and bears a filing date of July 25, 1996. In general, the ‘428 Patent relates to acknowledging receipt of data messages and probe messages. The Abstract of the ‘428 Patent states:

A network operations center transmits a data message to a wireless mobile unit and waits for a data acknowledgment message. If no acknowledgment is received within a specified time, the network operations center sends a probe message to attempt to locate the mobile unit and waits for a probe acknowledgment message. If still no acknowledgment, the network operations center marks the data message as undelivered and stores it for future delivery. If a mobile unit receives a probe message while its transmitter is powered off, it displays an indication to the subscriber that there is a message waiting to be delivered. The subscriber can then dial into the network operations center to retrieve the message. Or, when the transmitter of the mobile unit is powered back on, the mobile unit sends a registration message to the network operations center; and upon receiving the registration message, the network operations center automatically re-transmits the undelivered data message to the mobile unit.

**A. “network operation(s) center”**

Plaintiff’s Proposed Construction	Defendants’ Proposed Construction
No construction necessary; plain and ordinary meaning.	“central or distributed computers that control the operation of the network over which messages are sent and received”

Dkt. No. 107-2 at 6; Dkt. No. 110 at 7; Dkt. No. 116, Ex. A at 1 & 9. This term appears in Claim 1 of the '428 Patent and Claim 8 of the '506 Patent.

Shortly before the start of the March 7, 2014 hearing, the Court provided the parties with the following preliminary construction for this disputed term as to Claim 1 of the '428 Patent: "This term in the preamble of Claim 1 of the '428 Patent is not a limitation." As to Claim 8 of the '506 Patent, the Court preliminarily proposed that the term be construed to have its plain meaning.

(1) The Parties' Positions

Plaintiff submits that in Claim 1 of the '428 Patent, "network operations center" appears only in the preamble and is not limiting. Dkt. No. 107-2 at 6. Plaintiff also argues that "[b]ecause the Claims describe what the network operation[s] center is and what it does, its meaning will be readily apparent to the jury." *Id.* at 6-7. Finally, Plaintiff argues that Defendants' proposal of "control the operation of the network" is not supported and that Defendants' proposal of "central or distributed computers" "would only serve to confuse the jury because the patents only describe one computer." *Id.* at 7.

Defendants respond that "under [Plaintiff's] current infringement theory, any computer that is connected to and sends data over a network ostensibly qualifies as a NOC [(network operations center)]." Dkt. No. 110 at 7. Defendants argue that "[g]iven the lack of intrinsic evidence, to construe the claim fully and properly, the Court should look to extrinsic evidence," cited below. *Id.* at 8.

Plaintiff replies that it "does not contend that 'any computer that is connected to and sends data over a network ostensibly qualified as a NOC.'" Dkt. No. 115 at 2. Plaintiff also

argues that Defendants fail to “clarify[] what it means to ‘control’ the network” and fail to “explain what the limitation ‘central or distributed computers’ means.” *Id.* at 2-3.

At the March 7, 2014 hearing, the parties agreed that a “network operation center” is not something that resides in a subscriber mobile unit.

(2) Analysis

Claim 1 of the ‘428 Patent recites (emphasis added):

1. A *network operations center* for transmitting and receiving messages to and from a wireless mobile unit comprising:
  - means for transmitting messages to the mobile unit;
  - means for receiving acknowledgment messages from the mobile unit;
  - means for determining whether an acknowledgment message is an acknowledgment to a data message or an acknowledgment to a probe message;
  - means for transmitting a probe message to the mobile unit if, after transmitting a data message to the mobile unit, no data acknowledgment message is received; and
  - means for marking a data message as undelivered and storing the undelivered data message if, after transmitting a probe message to the mobile unit, no probe acknowledgment message is received.

Claim 8 of the ‘506 Patent recites (emphasis added):

8. A method of communicating messages between subscribers to an electronic messaging network, comprising the steps of:
  - maintaining, at a *network operation center*, a first file of canned messages and message codes respectively assigned to the canned messages;
  - maintaining at a first terminal of a first subscriber, a second file of canned messages and message codes corresponding to the first file;
  - maintaining, at a second terminal of a second subscriber, a third file of canned messages and message codes corresponding to the first file;
  - selecting an appropriate canned message from the second file for transmission to the second terminal;
  - sending the message code assigned to the selected canned message to the *network operation center*;
  - relaying the message code assigned to the selected canned message from the *network operation center* to the second terminal;
  - retrieving the selected canned message from the third file using the assigned message code received from the *network operation center*; and
  - displaying the selected canned message retrieved from the third file.



As to Claim 1 of the '428 Patent, the term "network operations center" appears only in the preamble and is not "necessary to give life, meaning, and vitality to the claim." *Catalina Mktg. Int'l, Inc. v. Coolsavings.com, Inc.*, 289 F.3d 801, 808 (Fed. Cir. 2002) (citation and internal quotation marks omitted). Instead, the "patentee defines a structurally complete invention in the claim body . . . ." *Id.* (citation and internal quotation marks omitted).

As to Claim 8 of the '946 Patent, the specification discloses:

It should be understood that, although FIG. 20 shows the *central computer* as existing at a single location in the network operations center 600, *a distributed computing system may be used* to perform the necessary functionality of the central computer 2002. Presently, however, a single location for the *central computer* 2002 is preferred.

'946 Patent at 20:5-9 (emphasis added).

As to extrinsic evidence, Defendants have cited a Technical Feasibility Demonstration, submitted to the FCC by Plaintiff in 1992, that refers to the "NOC" (network operations center) as the "nucleus" and "the heart" of the system. Dkt. No. 110, Ex. 9 at APL-MTEL-00284114. Defendants have also cited a technical dictionary definition of "network operations center" as: "[T]he central place which monitors the status of a corporate network and sends out instructions to repair bits and pieces of the network when they break. In more formal terms, monitoring of network status, supervision and coordination of network maintenance, accumulation of accounting and usage data and user support." *Id.*, Ex. 10, *Newton's Telecom Dictionary* 697 (8th ed. 1994); *see id.*, Ex. 11, *The New IEEE Standard Dictionary of Electrical and Electronics Terms* 685 (6th ed. 1996) ("A center that is responsible for the operational aspects of a network. *Note*: among these are monitoring and controlling, trouble-shooting, user assistance.").

On one hand, "[w]hen the intrinsic evidence is silent as to the plain meaning of a term, it is entirely appropriate for the district court to look to dictionaries or other extrinsic sources for

context—to aid in arriving at the plain meaning of a claim term.” *See Helmsderfer v. Bobrick Washroom Equip., Inc.*, 527 F.3d 1379, 1382 (Fed. Cir. 2008); *see also Phillips*, 415 F.3d at 1318.

On the other hand, “heavy reliance on the dictionary divorced from the intrinsic evidence risks transforming the meaning of the claim term to the artisan into the meaning of the term in the abstract, out of its particular context, which is the specification.” *Phillips*, 415 F.3d at 1321.

The above-quoted cautionary principle set forth in *Phillips* is the more compelling one as to the present disputed term. *See id.* Because Defendants’ proposed construction primarily merely rewords the disputed term itself, and because most of the additional language in Defendants’ proposal is based on extrinsic evidence, Defendants’ proposed construction is hereby expressly rejected.

On balance, in light of the parties’ binding agreement at the March 7, 2014 hearing that a “network operation center” is not something that resides in a subscriber mobile unit, and the fact that the language immediately surrounding the “network operation center” term provides ample context and meaning, no further construction is necessary. *See U.S. Surgical*, 103 F.3d at 1568; *see also O2 Micro*, 521 F.3d at 1362; *Finjan*, 626 F.3d at 1207.

The Court therefore hereby construes the disputed terms as set forth in the following chart:

<u>Term</u>	<u>Construction</u>
<b>“network operations center” (‘428 Patent, Claim 1)</b>	<b>This term in the preamble of Claim 1 of the ‘428 Patent is not a limitation.</b>
<b>“network operation center” (‘506 Patent, Claim 8)</b>	<b>Plain meaning</b>

**B. “probe message”**

Plaintiff’s Proposed Construction	Defendants’ Proposed Construction
No construction necessary; plain and ordinary meaning.	“a message sent by the network operations center to locate a mobile unit”

Dkt. No. 107-2 at 7; Dkt. No. 110 at 4; Dkt. No. 116, Ex. A at 2. This term appears in Claim 1 of the ‘428 Patent.

Shortly before the start of the March 7, 2014 hearing, the Court provided the parties with the following preliminary construction for this disputed term: “a message sent by the network operation center to locate a mobile unit.”

(1) The Parties’ Positions

Plaintiff argues that “[t]he plain and ordinary meaning of ‘probe message’ is clear from the context; it is a message that is sent to determine whether an address can be reached.” Dkt. No. 107-2 at 7. Plaintiff also argues that Defendants’ proposal of “locate” “improperly imports a limitation from the Specification.” *Id.* at 6-7. Plaintiff further argues that “[b]y including ‘locate,’ Defendants combine the functions of the ‘probe message’ and the ‘probe acknowledge message,’ which are parts of separate claim elements and together determine the location of a mobile unit in the network.” *Id.* Finally, Plaintiff argues that “Defendants’ proposed construction unnecessarily limits the origin of a message.” *Id.* at 8.

Defendants respond that their proposed construction is the explicit definition set forth in the specification. Dkt. No. 110 at 4 (citing ‘428 Patent at 4:26-40). Defendants argue that the extrinsic dictionary definition cited by Plaintiff cannot outweigh the intrinsic definition cited by Defendants. *Id.* at 5 (citing *TIP Sys., LLC v. Phillips & Brooks/Gladwin, Inc.*, 529 F.3d 1364, 1375 (Fed. Cir. 2008) (noting that “extrinsic evidence need be given little weight in the court’s claim construction if it is outweighed by clear intrinsic evidence”)).

Plaintiff replies that “a transmission need not be transmitted by a NOC in order to be a ‘probe message.’” Dkt. No. 115 at 1 (emphasis omitted).

(2) Analysis

Although Plaintiff has proposed that no construction is required, the parties have presented a “fundamental dispute regarding the scope of a claim term,” and the Court has a duty to resolve that dispute. *O2 Micro*, 521 F.3d at 1362-63.

Claim 1 of the ‘428 Patent recites (emphasis added):

1. A network operations center for transmitting and receiving messages to and from a wireless mobile unit comprising:
  - means for transmitting messages to the mobile unit;
  - means for receiving acknowledgment messages from the mobile unit;
  - means for determining whether an acknowledgment message is an acknowledgment to a data message or an acknowledgment to a *probe message*;
  - means for transmitting a *probe message* to the mobile unit if, after transmitting a data message to the mobile unit, no data acknowledgment message is received; and
  - means for marking a data message as undelivered and storing the undelivered data message if, after transmitting a *probe message* to the mobile unit, no probe acknowledgment message is received.

Plaintiff has cited an extrinsic technical dictionary definition of “probe” as: “An empty message that is sent to reach a particular address to determine if an address can be reached.” Dkt. No. 107, Ex. 1, *Newton’s Telecom Dictionary* 481 (11th ed. 1996). Although extrinsic evidence must be used with caution, technical dictionaries can be particularly useful. *Phillips*, 415 F.3d at 1318 (“Because dictionaries, and especially technical dictionaries, endeavor to collect the accepted meanings of terms used in various fields of science and technology, those resources have been properly recognized as among the many tools that can assist the court in determining the meaning of particular terminology to those of skill in the art of the invention.”). Nonetheless, “heavy reliance on the dictionary divorced from the intrinsic evidence risks

transforming the meaning of the claim term to the artisan into the meaning of the term in the abstract, out of its particular context, which is the specification.” *Id.* at 1321.

As to the purported intrinsic definition cited by Defendants, “the specification may reveal a special definition given to a claim term by the patentee that differs from the meaning it would otherwise possess. In such cases, the inventor’s lexicography governs.” *Phillips*, 415 F.3d at 1316. The specification discloses:

FIG. 2 shows a block diagram of a mobile unit 200, in accordance with a preferred embodiment of the present invention. Mobile unit 200 includes transmitter 202 . . . \* \* \*

Transmitter 202 transmits messages forwarded to it from controller 208. Preferably, transmitter 202 transmits at least three different types of messages: data messages, acknowledgment messages, and registration messages. There are preferably two forms of acknowledgment messages: data acknowledgment messages generated by a mobile unit to acknowledge receipt of data messages and probe acknowledgment messages generated by a mobile unit to acknowledge receipt of *probe messages (defined below)* transmitted from a network operations center. A registration message is generally a message generated by a mobile unit to update its location to the network operations center.

Receiver 204 receives messages and forwards them to controller 208. Receiver 204 preferably receives at least two different types of messages: data messages and probe messages. *A probe message, as described above, is generally a message generated by a network operations center to locate a mobile unit.*

‘428 Patent at 4:15-40 (emphasis added).

On balance, this statement of what “[a] probe message . . . is *generally* . . .” is equivocal and does not amount to a lexicography. *See In re Paulsen*, 30 F.3d 1475, 1480 (Fed. Cir. 1994) (“Although an inventor is indeed free to define the specific terms used to describe his or her invention, this must be done with reasonable clarity, deliberateness, and precision.”).

Although the Court thus rejects Defendants’ proposed lexicography, the above-quoted disclosure can nonetheless be considered as part of the context provide by the patent as a whole. *See Phillips*, 415 F.3d at 1313 (“Importantly, the person of ordinary skill in the art is deemed to

read the claim term not only in the context of the particular claim in which the disputed term appears, but in the context of the entire patent, including the specification.”). In addition, the specification discloses:

It is possible that the corresponding mobile unit will acknowledge a *probe message* but not a data message sent from the network operations center because the transmission range or strategy for a *probe message* may differ from that of a data message, *as described in the incorporated U.S. patent application Ser. No. 08/124,219* [(which issued as the ‘946 Patent)]. For example, a data message may be transmitted by the network operations center only to the last known location of the corresponding mobile unit. Therefore, if the mobile unit has moved, it may miss the data message. On the other hand, *a probe message is preferably broadcast by the network operations center to all locations covered by all base transmitters, so there is a very high likelihood that it will reach the corresponding mobile unit even if the mobile unit has moved.*

‘428 Patent at 7:59-8:5 (emphasis added). The ‘946 Patent, in turn, discloses:

[T]he systemwide time interval can be used to send a “*probe*” signal that requests a particular mobile unit to broadcast an acknowledgment signal to allow the system to determine its approximate location by determining which base receiver receives the acknowledgment signal. Probe signals, thereby, may be used to track the locations of mobile units, or to uncover the location of “lost” mobile units.

‘946 Patent at 10:1-8 (emphasis added).

Finally, the following parenthetical explanation appears in the Background of the Invention in the ‘428 Patent:

That application [that issued as the ‘946 Patent] describes that the mobile unit is capable of acknowledging that it accurately received a message sent from the network operations center. The acknowledgment, however, does not indicate whether it is acknowledging the receipt of a data message or a *probe message (a message sent by the network operations center to locate a mobile unit)*. Thus, there is a need for methods and devices that allow two-way communications between a network operations center and a personal mobile unit such that successfully delivered data messages and probe messages from the network operations center can be distinctively acknowledged by the mobile unit.

‘428 Patent at 1:39-40 (emphasis added).

The intrinsic evidence thus consistently demonstrates that although a probe message need not itself specify a location or contain location information, a probe message is generated for locating a mobile unit. This consistent context should be given effect in the construction of the disputed term “probe message.” See *Retractable Techs., Inc. v. Becton, Dickinson & Co.*, 653 F.3d 1296, 1305 (Fed. Cir. 2011) (“In reviewing the intrinsic record to construe the claims, we strive to capture the scope of the actual invention, rather than strictly limit the scope of claims to disclosed embodiments or allow the claim language to become divorced from what the specification conveys is the invention.”); see also *Nystrom v. TREX Co., Inc.*, 424 F.3d 1136, 1144-45 (Fed. Cir. 2005) (construing term “board” to mean “wood cut from a log” in light of the patentee’s consistent usage of the term; noting that patentee “is not entitled to a claim construction divorced from the context of the written description and prosecution history”); *Am. Piledriving Equip., Inc. v. Geoquip, Inc.*, 637 F.3d 1324, 1333 (Fed. Cir. 2011) (“[T]he consistent reference throughout the specification to the ‘eccentric weight portion’ as structure extending from the face of the gear makes it apparent that it relates to the invention as a whole, not just the preferred embodiment.”).

As to the origin of a probe message, the term “network operations center” appears in the preamble of the claim rather than in the body. The Court has therefore found, above, that the term “network operations center” is not a limitation of Claim 1 of the ‘428 Patent. Defendants’ proposal that a “probe message” must be sent “by the network operations center” is therefore hereby expressly rejected.

Finally, all parties agreed at the March 7, 2014 hearing that the word “sent” in Defendants’ proposed construction could be replaced with “generated” so as to better match the above-quoted disclosures in the specification. See ‘428 Patent at 4:38-40.

The Court therefore hereby construes “**probe message**” to mean “**a message that is generated to locate a mobile unit.**”

**C. “means for determining whether an acknowledgment message is an acknowledgment to a data message or an acknowledgment to a probe message”**

Plaintiff’s Proposed Construction	Defendants’
Function: “determining whether an acknowledgment message is an acknowledgment to a data message or an acknowledgment to a probe message”  Structure: “acknowledgment message processing (AMP) module 310, and/or memory 110 and processor 308 and equivalents”	Indefinite

Dkt. No. 107-2 at 23; *see* Dkt. No. 110 at 26-30; Dkt. No. 116, Ex. A at 2. This term appears in Claim 1 of the ‘428 Patent. The parties agree that this is a means-plus-function term subject to 35 U.S.C. § 112(f) (sometimes referred to as “§ 112, ¶ 6”). Dkt. No. 107-2 at 23; *see* Dkt. No. 110 at 27-30. Also, Defendants have not challenged Plaintiff’s proposal for the claimed function.

(1) The Parties’ Positions

Plaintiff argues that the specification sets forth adequate structure, in particular as illustrated in Figure 3. Dkt. No. 107-2 at 22-25.

Defendants respond:

[T]he [‘]428 Patent recites “[a]s AMP module 310 receives an acknowledgement message from MTD module 302, it first determines whether the message is a data acknowledgment message or a probe acknowledgement message.” [‘]428 Patent[] at 5:24-27. No further description is provided as to how this determination is functionally made, what logic or algorithms are employed, or any identification of specific structural components that would be utilized. Based on this limited disclosure, one of ordinary skill would not have known what structure the patentees had claimed.



Dkt. No. 110 at 28. Defendants argue that “rather than disclose the required algorithm for th[is] term[], the specification impermissibly restates the function recited in the claim.” *Id.* at 29 (citing ‘428 Patent at 4:61-5:1, 5:59-65, 6:4-8 & 6:49-54).

Plaintiff replies that no algorithm is required because “[t]he claim terms at issue fall within the *Katz* exception because the functions contained in those terms are performable by a general-purpose computer.” Dkt. No. 115 at 10 (citing *In re Katz Interactive Call Processing Patent Litig.*, 639 F.3d 1303, 1316 (Fed. Cir. 2011)). Alternatively, Plaintiff cites its opening brief and argues that “[Plaintiff] demonstrates that the ‘428 Patent contains sufficient algorithms for these terms.” Dkt. No. 115 at 10.

At the March 7, 2014 hearing, Plaintiff argued that the corresponding structure is not a general-purpose computer. Plaintiff submitted that if Defendants contend otherwise, then they have failed to meet their burden of presenting expert testimony regarding how a person of ordinary skill in the art would interpret the specification, as required by the recent *elcommerce* case. *elcommerce.com, Inc. v. SAP AG*, --- F.3d ---, 2014 WL 685622 (Fed. Cir. Feb. 24, 2014).<sup>6</sup>

## (2) Analysis

Defendants have not challenged Plaintiff’s identification of the corresponding structure in the specification, at least as set forth in Plaintiff’s proposed construction. *See* Dkt. No. 110 at 28-29. Instead, Defendants challenge the sufficiency of that structure, arguing that because the structure amounts to a general-purpose computer, an algorithm is required but is absent. Defendants also argue that the *Katz* exception to the algorithm requirement does not apply

---

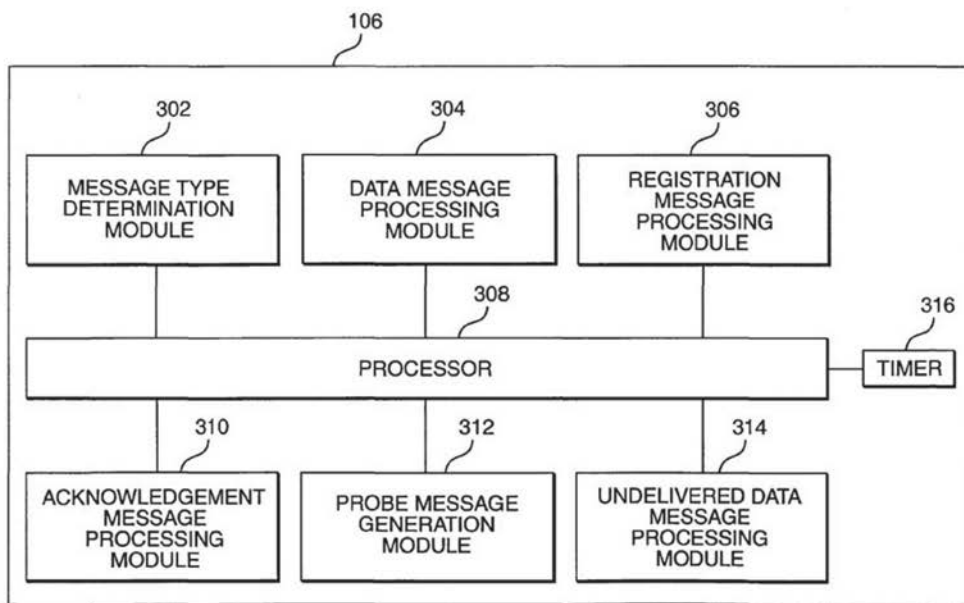
<sup>6</sup> The *elcommerce* case was decided after the close of briefing in the above-captioned case. Plaintiff filed a notice of supplemental authority prior to the March 7, 2014 hearing. *See* Dkt. No. 118, 2/25/2014 Notice of Supplemental Authority Recently Issued by Federal Circuit.

because “determining whether an acknowledgment message is an acknowledgment to a data message or an acknowledgment to a probe message” is not analogous to functions such as “processing,” “receiving,” or “storing” that can be performed by any general-purpose computer without special programming. *See In re Katz*, 639 F.3d at 1316.

Plaintiff has argued that no algorithm is required, but Plaintiff submits that if an algorithm is required then the specification discloses what Plaintiff refers to as an “if-then-else algorithm” for performing the claimed function:

As AMP [(acknowledgement message processing)] module 310 receives an acknowledgment message from MTD module 302, it first determines whether the message is a data acknowledgment message or a probe acknowledgment message. If it is the former, then AMP module 310 indicates to DMP module 304 to forward to message transmitting unit 108 the next data message in memory storage unit 110 waiting to be delivered to that subscriber. If it is the latter, then AMP module 310 updates in memory storage unit 110 the location of mobile unit 200 and indicates to DMP module 304 to re-send the last data message to message transmitting unit 108.

‘428 Patent at 5:24-34. This disclosure relates to Figure 3, which is reproduced here:



**FIG.3**

Plaintiff argues that “[a] PHOSITA [(person having ordinary skill in the art)] would recognize AMP module 310 as capable of determining the difference between a probe acknowledgement and data message acknowledgement ‘in accordance with conventional techniques.’” Dkt. No. 107-2 at 24 (quoting ‘428 Patent at 5:62) (emphasis omitted).

Also, as purported evidence of how a person of ordinary skill in the art would understand the ‘428 Patent, Plaintiff has cited disclosure in the related ‘946 Patent. *See* Dkt. No. 107-2 at 24-25; Dkt. No. 115 at 10. The ‘428 Patent incorporates the ‘946 Patent by reference. *See* ‘428 Patent at 1:36-39. The ‘946 Patent discloses:

Each mobile unit with transmit capability that has received a message in the immediately previous systemwide forward interval 2704 or the zonal forward interval 2708 will have an appropriate time slot for transmission scheduled in the systemwide response interval 2706, or the zonal reverse interval 2710, respectively. The timing circuit in the mobile transceiver unit determines the

assigned time slot for transmission. For example, if the mobile unit simply intends to transmit an acknowledgment signal, which indicates that the mobile unit has properly received the message from the network, an 8 bit preamble followed by the address of that mobile unit need only be transmitted and a 3 bit acknowledgment.

'946 Patent at 27:40-53; *see id.* at Fig. 27(A). Plaintiff explains that “the AMP module 310 may determine the ACK type based on when it received the ACK. As shown in FIG. 27(A) of the '946 Patent . . . , a probe ACK (with a proper address for a mobile unit) is expected during Systemwide Reverse Interval 2706 while a message ACK may be expected in Zonal Reverse Interval 2710.” Dkt. No. 107-2 at 24-25.

Title 35 U.S.C. § 112(f) provides: “An element in a claim for a combination may be expressed as a means or step for performing a specified function without the recital of structure, material, or acts in support thereof, and such claim shall be construed to cover the corresponding structure, material, or acts described in the specification and equivalents thereof.” Further, “[t]he scope of a claim under [35 U.S.C.] section 112[(f)] . . . must be limited to structures *clearly linked or associated* with the claimed function in the specification or prosecution history and equivalents of those structures.” *Med. Instrumentation & Diagnostics Corp. v. Elekta AB*, 344 F.3d 1205, 1219 (Fed. Cir. 2003) (emphasis added).

“[A] means-plus-function claim element for which the only disclosed structure is a general purpose computer is invalid if the specification fails to disclose an algorithm for performing the claimed function.” *Net MoneyIN, Inc. v. VeriSign, Inc.*, 545 F.3d 1359, 1367 (Fed. Cir. 2008); *see WMS Gaming, Inc. v. Int'l Game Tech.*, 184 F.3d 1339, 1349 (Fed. Cir. 1999) (“In a means-plus-function claim in which the disclosed structure is a computer, or microprocessor, programmed to carry out an algorithm, the disclosed structure is not the general

purpose computer, but rather the special purpose computer programmed to perform the disclosed algorithm.”).

There is, however, an exception to the general rule requiring an algorithm. Specifically, when the corresponding structure is a general purpose computer, an algorithm is required *unless* the recited function can be achieved by any general purpose computer without special programming. *In re Katz*, 639 F.3d at 1316 (“Absent a possible narrower construction of the terms ‘processing,’ ‘receiving,’ and ‘storing,’ . . . those functions can be achieved by any general purpose computer without special programming. As such, it was not necessary to disclose more structure than the general purpose processor that performs those functions.”); *accord Ergo Licensing, LLC v. CareFusion 303, Inc.*, 673 F.3d 1361, 1365 (Fed. Cir. 2012) (“In *In re Katz*, we held that ‘[a]bsent a possible narrower construction’ of the terms ‘processing,’ ‘receiving,’ and ‘storing,’ the disclosure of a general-purpose computer was sufficient. . . . In other words, a general-purpose computer is sufficient structure if the function of a term such as ‘means for processing’ requires no more than merely ‘processing,’ which any general-purpose computer may do without any special programming.”) (citations omitted); *but see id.* (“It is only in the rare circumstances where any general-purpose computer without any special programming can perform the function that an algorithm need not be disclosed.”).

If an algorithm is required, that algorithm may be disclosed in any understandable form. *See Typhoon Touch Techs., Inc. v. Dell, Inc.*, 659 F.3d 1376, 1386 (Fed. Cir. 2011) (“Indeed, the mathematical algorithm of the programmer is not included in the specification. However, as precedent establishes, it suffices if the specification recites in prose the algorithm to be implemented by the programmer.”); *see also Finisar Corp. v. DirecTV Group, Inc.*, 523 F.3d 1323, 1340 (Fed. Cir. 2008) (noting that “a patentee [may] express th[e] algorithm in any

understandable terms including as a mathematical formula, in prose, or as a flow chart, or in any other manner that provides sufficient structure”) (citation omitted); *TecSec, Inc. v. Int’l Bus. Machs. Corp.*, 731 F.3d 1336, 1348 (Fed. Cir. 2013) (discussing *Finisar*).

Nonetheless, the purported algorithm must provide a “step-by-step procedure” for accomplishing the claimed function and cannot “merely provide[] functional language.” *Ergo Licensing*, 673 F.3d at 1365; *see, e.g., Rotatable Techs. LLC v. Nokia Inc.*, No. 2:12-CV-265, 2013 WL 3992930, at \*4 (E.D. Tex. Aug. 2, 2013) (Gilstrap, J.). Further, “[i]t is well settled that simply disclosing software, however, without providing some detail about the means to accomplish the function, is not enough.” *Function Media, LLC v. Google, Inc.*, 708 F.3d 1310, 1318 (Fed. Cir. 2013) (citation and internal quotations and alterations omitted).

Claim 1 of the ‘428 Patent recites (emphasis added):

1. A network operations center for transmitting and receiving messages to and from a wireless mobile unit comprising:
  - means for transmitting messages to the mobile unit;
  - means for receiving acknowledgment messages from the mobile unit;
  - means for determining whether an acknowledgment message is an acknowledgment to a data message or an acknowledgment to a probe message;*
  - means for transmitting a probe message to the mobile unit if, after transmitting a data message to the mobile unit, no data acknowledgment message is received; and
  - means for marking a data message as undelivered and storing the undelivered data message if, after transmitting a probe message to the mobile unit, no probe acknowledgment message is received.

As corresponding structure for the “means for determining . . .,” Plaintiff proposes: “acknowledgment message processing (AMP) module 310, and/or memory 110 and processor 308 and equivalents.” *See* ‘428 Patent at 4:61-5:34.

In some contexts, a person of ordinary skill in the art can interpret disclosure of an element in terms of what it does, without any description of its internal structure or operation, as sufficient corresponding structure. *See Telcordia Techs., Inc. v. Cisco Sys., Inc.*, 612 F.3d 1365,

1377 (Fed. Cir. 2010) (as to disclosure of “controllers” in the specification, finding that “the absence of internal circuitry in the written description does not automatically render the claim indefinite. . . . [C]laim definiteness depends on the skill level of an ordinary artisan. Therefore, the specification need only disclose adequate defining structure to render the bounds of the claim understandable to an ordinary artisan.”) (citations and internal quotation marks omitted).

Although Defendants argue that the disclosures cited by Plaintiff do not contain sufficient structure or any algorithm, Defendants have failed to present any evidence of the understanding of a person of ordinary skill in the art, such as through an expert declaration or expert testimony. Defendants have therefore failed to meet their burden of proving indefiniteness by clear and convincing evidence. *See elcommerce.com*, 2014 WL 685622, at \*15 (“The burden was on SAP to prove its case, and in the absence of evidence provided by technical experts who meet the *Daubert* criteria there is a failure of proof. Attorney argument is not evidence.”); *see also id.* at \*1, \*12, \*14; *but see id.* at \*16 (Wallach, J., dissenting); *Noah Sys. v. Intuit Inc.*, 675 F.3d 1302, 1313-17, 1319 (Fed. Cir. 2012).

Defendants’ indefiniteness argument is therefore hereby expressly rejected. This rejection is without prejudice because the *elcommerce* decision was handed down after the close of claim construction briefing in the above-captioned case.

The Court accordingly hereby finds that for the “**means for determining whether an acknowledgment message is an acknowledgment to a data message or an acknowledgment to a probe message,**” the function is “**determining whether an acknowledgment message is an acknowledgment to a data message or an acknowledgment to a probe message,**” and the corresponding structure is “**acknowledgment message processing (AMP) module 310, and/or memory 110 and processor 308; and equivalents thereof.**”

**D. “means for generating, upon power restoration to the transmitter, a registration message if a probe message has been received while the transmitter was powered off, said registration message being transmitted by said transmitter”**

Plaintiff’s Proposed Construction	Defendants’
Function: “generating, upon power restoration to the transmitter, a registration message if a probe message has been received while the transmitter was powered off, said registration message being transmitted by said transmitter”  Structure: “registration message generation module 404 and/or memory 212 and processor 406, and equivalents”	Indefinite

Dkt. No. 107-2 at 25; *see* Dkt. No. 110 at 26-30; Dkt. No. 116, Ex. A at 6. This term appears in Claim 4 of the ‘428 Patent. The parties agree that this is a means-plus-function term subject to 35 U.S.C. § 112(f). *See* Dkt. No. 107-2 at 25-26; Dkt. No. 110 at 27-30. Also, Defendants have not challenged Plaintiff’s proposal for the claimed function.

(1) The Parties’ Positions

Plaintiff argues that the specification sets forth adequate structure, in particular as illustrated in Figure 4. Dkt. No. 107-2 at 25-26.

Defendants respond:

[T]he [‘]428 Patent specification again inadequately provides only a “black box” description, reciting a “registration message generation (RMG) module 404” that “creates a registration message and forwards it to transmitter 202” after checking memory 212 for an indication that a probe message has been received when the transmitter 202 was powered off. [‘428 Patent] at 6:6-8, 6:41-47.

Dkt. No. 110 at 28. Defendants argue that “rather than disclose the required algorithm for th[is] term[], the specification impermissibly restates the function recited in the claim.” *Id.* at 29 (citing ‘428 Patent at 4:61-5:1, 5:59-65, 6:4-8 & 6:49-54).



Plaintiff replies that no algorithm is required because “[t]he claim terms at issue fall within the *Katz* exception because the functions contained in those terms are performable by a general-purpose computer.” Dkt. No. 115 at 10 (citing *In re Katz*, 639 F.3d at 1316). Alternatively, Plaintiff cites its opening brief and argues that “[Plaintiff] demonstrates that the ‘428 Patent contains sufficient algorithms for these terms.” Dkt. No. 115 at 10.

At the March 7, 2014 hearing, Plaintiff argued that the corresponding structure is not a general-purpose computer. Plaintiff submitted that if Defendants contend otherwise, then they have failed to meet their burden of presenting expert testimony regarding how a person of ordinary skill in the art would interpret the specification, as required by the recent *elcommerce* case. *elcommerce.com*, 2014 WL 685622.

## (2) Analysis

Relevant legal principles are discussed as to the “means for determining . . .” term, above. Claim 4 of the ‘428 Patent recites (emphasis added):

4. A wireless mobile unit for receiving and transmitting messages from and to a network operations center comprising:
  - means for receiving data and probe messages from the network operations center;
  - a transmitter;
  - means for generating, upon receiving a data message, a data acknowledgment message, said data acknowledgment message being transmitted by said transmitter;
  - means for generating, upon receiving a probe message, a probe acknowledgment message, said probe acknowledgment message being transmitted by said transmitter;
  - means for powering the transmitter on and off;
  - means for determining whether a probe message has been received while said transmitter was powered off; and
  - means for generating, upon power restoration to the transmitter, a registration message if a probe message has been received while the transmitter was powered off, said registration message being transmitted by said transmitter.*

The specification discloses:

FIG. 4 shows a block diagram of controller 208 of mobile unit 200, in accordance with a preferred embodiment of the present invention. Preferably, controller 208 includes acknowledgment message generation (AMG) module 402, *registration message generation (RMG) module 404*, processor 406, message type determination (MTD) module 408, probe message processing (PMP) module 410, and data message processing (DMP) module 412.

\* \* \*

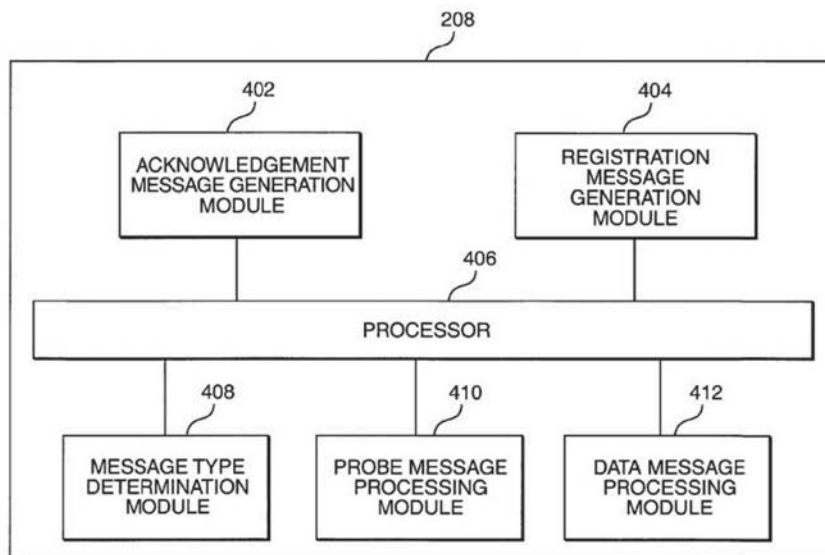
RMG module 404 generates registration messages. In a preferred embodiment of the present invention, as transmitter 202 is powered on, RMG module 404 checks memory 212 for an indication that a probe message has been received when transmitter 202 is off. If such an indication exists, then RMG module 404 creates a registration message and forwards it to transmitter 202.

In a preferred embodiment, modules 402, 404, 408, 410, and 412 comprise software or microcode and any hardware necessary to effect the execution of that software or microcode in accordance with conventional techniques. In an alternative embodiment, modules 402, 404, 408, 410, and 412 can be implemented in electronic logic circuitry. Processor 406 is preferably any processor capable of executing the foregoing software or microcode and performing the processing functions described herein.

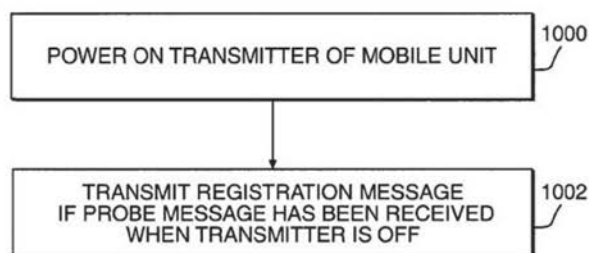
\* \* \*

FIG. 10 shows a flow diagram depicting the operation of mobile unit 200 in registering upon power restoration to transmitter 202, in accordance with a preferred embodiment of the present invention. Transmitter 202 is turned back on, for example, when a subscriber traveling on an airplane lands (step 1000). RMG module 404 checks memory 212 for control information indicating that mobile unit 200 has received a probe message when transmitter 202 is off. If such an indication exists, then RMG module 404 sends a registration message through transmitter 202 to network operations center 100 to update the current location of mobile unit 200 (step 1002).

'428 Patent at 6:4-11, 6:42-57 & 8:63-9:7 (emphasis added). Figures 4 and 10 are reproduced here;



**FIG. 4**



**FIG. 10**

As corresponding structure for the “means for generating . . .,” Plaintiff proposes: “registration message generation module 404 and/or memory 212 and processor 406, and equivalents.” *See* ‘428 Patent at 6:42-57. Defendants have not challenged Plaintiff’s identification of the corresponding structure in the specification, at least as set forth in Plaintiff’s proposed construction. *See* Dkt. No. 110 at 28-29. Instead, Defendants challenge the sufficiency

of that structure, arguing that because the structure amounts to a general-purpose computer, an algorithm is required but is absent.

For the same reasons discussed above as to the “means for determining . . .,” although Defendants argue that the disclosures cited by Plaintiff do not contain sufficient structure or any algorithm, Defendants have failed to present any evidence of the understanding of a person of ordinary skill in the art, such as through an expert declaration or expert testimony. Defendants have therefore failed to meet their burden to prove indefiniteness by clear and convincing evidence. *See elcommerce.com*, 2014 WL 685622, at \*15; *but see Noah Sys.*, 675 F.3d at 1313-17, 1319.

Defendants’ indefiniteness argument is therefore hereby expressly rejected. This rejection is without prejudice because the *elcommerce* decision was handed down after the close of claim construction briefing in the above-captioned case.

The Court accordingly hereby finds that for the **“means for generating, upon power restoration to the transmitter, a registration message if a probe message has been received while the transmitter was powered off, said registration message being transmitted by said transmitter,”** the function is **“generating, upon power restoration to the transmitter, a registration message if a probe message has been received while the transmitter was powered off, said registration message being transmitted by said transmitter,”** and the corresponding structure is **“registration message generation module 404 and/or memory 212 and processor 406; and equivalents thereof.”**

**E. “means for powering the transmitter on and off”**

Plaintiff’s Proposed Construction	Defendants’ Proposed Construction
Function: “powering the transmitter on and off”  Structure: “transmitter power switch 504; or mobile unit power switch 508, and equivalents”	Function: “powering the transmitter on and off independently of the receiver”  Structure: “transmitter power switch 504”

Dkt. No. 107-2 at 29; Dkt. No. 110 at 6; Dkt. No. 116, Ex. A at 5. This term appears in Claim 4 of the ‘428 Patent. The parties agree that this is a means-plus-function term subject to 35 U.S.C. § 112(f). Dkt. No. 107-2 at 29-30; *see* Dkt. No. 110 at 6-7.

Shortly before the start of the March 7, 2014 hearing, the Court provided the parties with the following preliminary construction for this disputed term: “Function: ‘powering the transmitter on and off’; Structure: ‘transmitter power switch 504; and equivalents thereof.’” At the March 7, 2014 hearing, all parties agreed to the Court adopting its preliminary construction.

The Court therefore hereby finds that for the “**means for powering the transmitter on and off,**” the function is “**powering the transmitter on and off,**” and the corresponding structure is “**transmitter power switch 504; and equivalents thereof.**”

**F. Additional Means-Plus-Function Terms**

Defendants have also submitted:

The deficiencies identified above apply to all of the means-plus-function terms identified in Exhibit 19.[fn 23] Accordingly, asserted claims 1, 2, and 4 of the [‘]428 Patent are invalid as indefinite.

[fn 23: The term “means for marking a data message as undelivered and storing the undelivered data message if, after transmitting a probe message to the mobile unit, no probe acknowledgment message is received” corresponds to, *inter alia*, black-box element “undelivered data message processing (UDMP) module 314.” [‘]428 Patent[] at 5:50-53. The term “means for generating, upon receiving a data message, a data acknowledgment message, said data acknowledgment message

being transmitted by said transmitter” corresponds to, *inter alia*, black-box element “acknowledgement message generation (AMG) module 402.” *Id.* at 6:15-19, 6:37-41. The term “means for generating, upon receiving a probe message, a probe acknowledgment message, said probe acknowledgment message being transmitted by said transmitter” corresponds to, *inter alia*, black-box element “acknowledgement message generation (AMG) module 402.” *Id.* at 6:19-21, 6:27-32, 6:37-41. The term “means for determining whether a probe message has been received while said transmitter was powered off” corresponds to, *inter alia*, black-box element “registration message generation (RMG) module 404.” *Id.* at 6:41-46. The term “means for automatically transmitting undelivered data messages to the mobile unit upon receiving a registration message from the mobile unit” corresponds to, *inter alia*, black-box element “registration message processing (RMP) module 306.” *Id.* at 5:54-59.

Dkt. No. 110 at 30 & n.23; *see* Dkt. No. 116, Ex. A at 3-6.

Defendants’ assertions of indefiniteness as to these additional means-plus-function terms suffer from the same defect discussed above as to the “means for determining . . .” and “means for generating . . .” terms. Specifically, Defendants have failed to present any evidence of the understanding of a person of ordinary skill in the art, such as through an expert declaration or expert testimony. Defendants have therefore failed to meet their burden to prove indefiniteness by clear and convincing evidence. *See elcommerce.com*, 2014 WL 685622, at \*15; *but see Noah Sys.*, 675 F.3d at 1313-17, 1319.

Defendants’ indefiniteness arguments are therefore hereby expressly rejected. This rejection is without prejudice because the *elcommerce* decision was handed down after the close of claim construction briefing in the above-captioned case.

The Court accordingly hereby construes these additional means-plus-function terms as set forth in the following chart:

<u>Term</u>	<u>Construction</u>
<p><b>“means for marking a data message as undelivered and storing the undelivered data message if, after transmitting a probe message to the mobile unit, no probe acknowledgment message is received”</b>                      (‘428 Patent, Claim 1)</p>	<p>Function:                      “marking a data message as undelivered and storing the undelivered data message if, after transmitting a probe message to the mobile unit, no probe acknowledgement message is received”</p> <p>Structure:                      “undelivered data message processing module 314 and/or memory 110 and processor 308; and equivalents thereof”</p>
<p><b>“means for generating, upon receiving a data message, a data acknowledgment message, said data acknowledgment message being transmitted by said transmitter”</b>                      (‘428 Patent, Claim 4)</p>	<p>Function:                      “generating, upon receiving a data message, a data acknowledgement message, said data acknowledgement message being transmitted by said transmitter”</p> <p>Structure:                      “acknowledgement message generating module 402 and/or memory 212 and processor 406; and equivalents thereof”</p>
<p><b>“means for generating, upon receiving a probe message, a probe acknowledgment message, said probe acknowledgment message being transmitted by said transmitter”</b>                      (‘428 Patent, Claim 4)</p>	<p>Function:                      “generating, upon receiving a probe message, a probe acknowledgement message, said probe acknowledgement message being transmitted by said transmitter”</p> <p>Structure:                      “acknowledgement message generating module 402 and/or memory 212 and processor 406; and equivalents thereof”</p>
<p><b>“means for determining whether a probe message has been received while said transmitter was powered off”</b>                      (‘428 Patent, Claim 4)</p>	<p>Function:                      “determining whether a probe message has been received while said transmitter was powered off”</p> <p>Structure:                      “registration message generating module 404 and/or memory 212 and processor 406; and equivalents thereof”</p>

<p><b>“means for automatically transmitting undelivered data messages to the mobile unit upon receiving a registration message from the mobile unit” (‘428 Patent, Claim 2)</b></p>	<p>Function:  <b>“automatically transmitting undelivered data messages to the mobile unit upon receiving a registration message from the mobile unit”</b></p> <p>Structure:  <b>“message transmitting unit 108; and equivalents thereof”</b></p>
---	--

**CONSTRUCTION OF DISPUTED TERMS IN U.S. PATENT NO. 5,894,506**

The ‘506 Patent is titled “Method and Apparatus for Generating and Communicating Messages Between Subscribers to an Electronic Message Network.” The ‘506 Patent issued on April 13, 1999, and bears a filing date of September 5, 1996. In general, the ‘506 Patent relates to conveying so-called “canned” messages by using codes. The Abstract of the ‘506 Patent states:

An electronic messaging network comprises a network operation center and plural message terminals, all including memories for storing corresponding files of canned messages and associated message codes. To send a canned message, a calling party selects a canned message stored at one message terminal and transmits the assigned message code to a receiving party at another message terminal via the network operation center. The receiving terminal retrieves the selected canned message from its memory using the received message code for display to the receiving party. Files of canned responses and associated response codes may also be stored in the memories at the terminals and network operation center to allow the exchange of selected canned response options in conjunction with canned messages to be in response code form.



**A. “canned message” and “canned multiple response options”**

<b>“canned message” (Claim 8)</b>	
<b>Plaintiff’s Proposed Construction</b>	<b>Defendants’ Proposed Construction</b>
No construction necessary; plain and ordinary meaning.  <i>Alternatively:</i> “a predefined message”	“previously stored textual word or phrase”  <i>Alternatively:</i> “previously stored sequence of text” or “previously stored sequence of characters”
<b>“canned multiple response options” (Claim 12)</b>	
<b>Plaintiff’s Proposed Construction</b>	<b>Defendants’ Proposed Construction</b>
No construction necessary; plain and ordinary meaning.  <i>Alternatively:</i> “predefined response that is available for user selection” <sup>7</sup>	“previously stored response to canned message”

Dkt. No. 107-2 at 10; Dkt. No. 110 at 9-10; Dkt. No. 116, Ex. A at 9 & 13.

Shortly before the start of the March 7, 2014 hearing, the Court provided the parties with the following preliminary constructions for these disputed terms: “canned message” means “predefined message”; and “canned multiple response options” means “predefined responses to a canned message.” At the March 7, 2014 hearing, all parties agreed to the Court adopting its preliminary construction of “canned multiple response options.” The parties did not reach agreement as to “canned message.” The following discussion therefore addresses only the term “canned message.”

<sup>7</sup> Plaintiff previously proposed: “predefined response messages available for user selection.” Dkt. No. 107-2 at 10.

(1) The Parties' Positions

Plaintiff argues that Defendants' proposal is too narrow because "the '506 Patent does not prohibit a message from being expressed by characters or symbols" and because "the Specification contemplates the canned messages being 'updated.'" Dkt. No. 107-2 at 10. "Finally," Plaintiff argues, "the storage of responses and canned messages is clear from the claim language itself." *Id.* at 11.

Defendants respond that "[t]he method disclosed in the [']506 Patent is predicated on a user selecting an appropriate textual message from a list already stored at the user's messaging terminal." Dkt. No. 110 at 9 (citing '506 Patent at 1:57-60 & 3:44-54). As to Plaintiff's objection to Defendants' proposed construction, Defendants respond that "a textual word or phrase certainly includes characters and may include symbols." *Id.* Alternatively, Defendants submit that "[i]f [Plaintiff's] objection is simply to the inclusion of 'word or phrase,' Defendants would be willing to accept 'previously stored sequence of text' in the alternative." *Id.* at 9 n.9. Finally, Defendants respond that "nothing in Defendants' construction prohibits the list of stored canned messages from being modified or updated." *Id.* at 9-10.

Plaintiff replies that "Defendants, for the first time in their response, add that their construction could also include 'symbols,' but do not explain the meaning of 'symbol' or concede that a symbol would cover an emoticon.<sup>8</sup> This construction would not be helpful to the jury, as it would necessitate further claim construction over the meaning of the words of the construction." Dkt. No. 115 at 3.

At the March 7, 2014 hearing, Defendants submitted, as another alternative proposed construction: "previously stored sequence of characters."

---

<sup>8</sup> An example of an "emoticon" is the well-known smiley face: ":-)".

(2) Analysis

Claims 8 and 12 of the '506 Patent recite (emphasis added):

8. A method of communicating messages between subscribers to an electronic messaging network, comprising the steps of:  
maintaining, at a network operation center, a first file of *canned messages* and message codes respectively assigned to the *canned messages*;  
maintaining at a first terminal of a first subscriber, a second file of *canned messages* and message codes corresponding to the first file;  
maintaining, at a second terminal of a second subscriber, a third file of *canned messages* and message codes corresponding to the first file;  
selecting an appropriate *canned message* from the second file for transmission to the second terminal;  
sending the message code assigned to the selected *canned message* to the network operation center;  
relaying the message code assigned to the selected *canned message* from the network operation center to the second terminal;  
retrieving the selected *canned message* from the third file using the assigned message code received from the network operation center; and  
displaying the selected *canned message* retrieved from the third file.

\* \* \*

12. The method defined in claim 11, further including the steps of:  
maintaining at the network operation center, a fourth file of *canned multiple response options* and response codes respectively assigned to the *canned multiple response options*;  
maintaining at the first terminal, a fifth file of *canned multiple response options* and response codes corresponding to the fourth file; and  
maintaining, at the second terminal, a sixth file of *canned multiple response options* and response codes corresponding to the fourth file;  
wherein the selecting step further includes  
the step of selecting appropriate *canned multiple response options* from the fifth file;  
the sending step further includes the step of sending the response codes assigned to the selected *multiple response options* together with the message code to the network operation center;  
the relaying step further includes the step of relaying the message and response codes from the network operation center to the second terminal; and  
the retrieving step further includes the step of retrieving the selected *canned multiple response options* from the sixth file using the assigned response codes received from the network operation center.

As a threshold matter, Defendants' proposal of "previously stored" is redundant of other claim language, such as the recital that canned messages and canned multiple response options are stored in "files." Defendants' proposals in that regard are therefore hereby expressly rejected.

As to the proper construction, the '506 Patent consistently refers to canned messages as being "text" or "phrases," including in the Summary of the Invention:

It is accordingly a principle object of the present invention to provide an improved electronic messaging network and method, wherein communications link capacity is conserved by transmitting certain messages with an improved degree of message compression.

Particularly in the case of radio paging, many paging messages consist[] of a relatively small number of common *phrases*, such as "I am on the way home", "I am working late", "Can we meet for lunch", etc. This being the case, such commonly used *phrases* can be treated as "canned" messages that can be replaced by short message codes as simple as, for example, one or several *ASCII* [(American Standard Code for Information Interchange)] *characters*.

'506 Patent at 1:38-49 (emphasis added). The specification likewise discloses:

The calling party browses through the file to determine if the *text of any of the canned messages* is appropriate to convey the particular message that the calling party wishes to send to the receiving party.

*Id.* at 3:50-54 (emphasis added); *see id.* at 4:4-5 ("I am on my way home" described as "canned message"); *see also id.* at 4:15-16, 4:56-59 & 5:24-26 (similar).

NOC [(network operations center)] 12 determines whether the designated receiving party terminal can accept the canned message in code form, i.e., as received from the sending party terminal, or whether the canned message must be transmitted in *full text* to the receiving party terminal (step 56 [in Figure 3]).

*Id.* at 6:7-12 (emphasis added); *see id.* at 6:38-41 ("The retrieved canned message, response options, and parameters, if any, are *displayed in text form* for viewing by the receiving party terminal (step 74 [in Figure 4]).") (emphasis added).

A coder/decoder 124 *encodes text messages* transmitted by the terminal to NOC 12 and *decodes text messages* received from NOC, including selected response options in *text code* received from a receiving terminal 14.

*Id.* at 7:56-60 (emphasis added).

Finally, Claim 1 of the '506 Patent recites steps of (emphasis added): “determining whether the second terminal can receive the *canned message* in a *text form or message code form*”; and “communicating the selected *canned message* to the second terminal in either *message code form or text code form* in response to the determination.” See *Phillips*, 415 F.3d at 1314 (“Other claims of the patent in question, both asserted and unasserted, can also be valuable sources of enlightenment as to the meaning of a claim term.”).

These consistent references to text weigh in favor of a construction that excludes, for example, photographs or videos. See *Retractable*, 653 F.3d at 1305 (“In reviewing the intrinsic record to construe the claims, we strive to capture the scope of the actual invention, rather than strictly limit the scope of claims to disclosed embodiments or allow the claim language to become divorced from what the specification conveys is the invention.”); see also *Nystrom*, 424 F.3d at 1144-45 (construing term “board” to mean “wood cut from a log” in light of the patentee’s consistent usage of the term; noting that patentee “is not entitled to a claim construction divorced from the context of the written description and prosecution history”); *Am. Piledriving Equip.*, 637 F.3d at 1333 (“[T]he consistent reference throughout the specification to the ‘eccentric weight portion’ as structure extending from the face of the gear makes it apparent that it relates to the invention as a whole, not just the preferred embodiment.”).

Moreover, Plaintiff argued in its opening brief that (emphasis added): “A PHOSITA [(person having ordinary skill in the art)] would understand the plain and ordinary meaning of ‘canned’ to be ‘predefined’ and ‘message’ to be ‘a *sequence of characters* used to convey

information or data.” Dkt. No. 107-2 at 10 (quoting Dkt. No. 107, Ex. 1, *Newton’s Telecom Dictionary* 373 (11th ed. 1996)) (“A sequence of characters used to convey information or data. In data communications, messages are usually in an agreed format with a heading which establishes the address to which the message will be sent and the text which is the actual message and maybe some information to signify the end of the message.”); see *Phillips*, 415 F.3d at 1318 (“Because dictionaries, and especially technical dictionaries, endeavor to collect the accepted meanings of terms used in various fields of science and technology, those resources have been properly recognized as among the many tools that can assist the court in determining the meaning of particular terminology to those of skill in the art of the invention.”).

Further, Defendants acknowledge that “a textual word or phrase certainly includes characters and may include symbols.” Dkt. No. 110 at 9.

The last remaining issue, posed by Plaintiff, is whether the word “text” or the word “symbol” would “exclude the accused ‘emoticons.’” See Dkt. No. 115 at 3. The ‘506 Patent does not discuss emoticons, and Plaintiff has not identified any evidence that would warrant referring to emoticons in the Court’s construction or making any findings at this time regarding emoticons. On balance, Plaintiff has raised a factual issue of infringement rather than a legal issue of claim construction. See *PPG Indus.*, 156 F.3d at 1355 (noting that “the task of determining whether the construed claim reads on the accused product is for the finder of fact”). As a result, no construction is required as to “symbols” or “emoticons.”

Instead, the Court uses the word “characters” because that word is used by the technical dictionary quoted in Plaintiff’s opening brief, as discussed above, and is consistent with the intrinsic evidence, such as the above-quoted disclosure regarding ASCII characters. The Court accordingly hereby construes the disputed terms as set forth in the following chart:

<u>Term</u>	<u>Construction</u>
“canned message”	“predefined sequence of characters”
“canned multiple response options”	“predefined responses to a canned message”

**B. “message code” and “response code”**

<b>“message code” (Claim 8)</b>	
<b>Plaintiff’s Proposed Construction</b>	<b>Defendants’ Proposed Construction</b>
No construction necessary; plain and ordinary meaning.	“code that is assigned to a canned message that requires less data to transmit than the message itself”
<b>“response code” (Claim 12)</b>	
<b>Plaintiff’s Proposed Construction</b>	<b>Defendants’ Proposed Construction</b>
No construction necessary; plain and ordinary meaning.	“code that is assigned to a canned response that requires less data to transmit than the response itself”

Dkt. No. 107-2 at 11; Dkt. No. 110 at 10; Dkt. No. 116, Ex. A at 9 & 13.

Shortly before the start of the March 7, 2014 hearing, the Court provided the parties with the following preliminary construction for these disputed terms: “message code” and “response code” have their plain meaning. At the March 7, 2014 hearing, the parties did not reach agreement as to any construction, but all parties nonetheless agreed that a “message code” is something that corresponds to a “canned message.”

Plaintiff argues that “[w]hile it is an objective of the invention to transmit ‘certain messages with an improved degree of message compression,’ the claims are not so limited.”

Dkt. No. 107-2 at 11-12 (quoting ‘506 Patent at 1:41-42). Defendants respond that “[Plaintiff’s]

proposed construction of plain meaning ignores the context provided in the [']506 Patent and encompasses the prior art character coding that the [']506 Patent was trying to improve upon.” Dkt. No. 110 at 11. Plaintiff’s reply brief does not address “message code” or “response code.” See Dkt. No. 115.

Claims 8 and 12 of the ‘506 Patent are set forth in the discussion of “canned message” and “canned multiple response options,” above. The Summary of the Invention discloses:

It is accordingly a *principle object of the present invention* to provide an improved electronic messaging network and method, wherein *communications link capacity is conserved* by transmitting certain messages with an improved degree of *message compression*.

Particularly in the case of radio paging, many paging messages consist[] of a relatively small number of common phrases, such as “I am on the way home”, “I am working late”, “Can we meet for lunch”, etc. This being the case, such commonly used phrases can be treated as “canned” messages that can be replaced by *short message codes* as simple as, for example, one or several ASCII characters.

The present invention takes advantage of this fact by providing, *in accordance with one preferred embodiment*, a method of communicating messages between subscribers of an electronic messaging network, comprising the steps of maintaining, at a network operation center, a first file of canned messages individually retrievable using unique, *abbreviated message codes* respectively assigned to the canned messages . . . .

‘506 Patent at 1:38-57 (emphasis added).

Assume, for example, that the canned message selected by the calling party in step 26 [in Figure 2] is “I am on my way home”. This canned message does not call for the addition of parameters. The associated *code* for this canned message, may be, for example, the number 36 in ASCII code.

*Id.* at 4:4-8 (emphasis added).

On balance, although reducing the amount of data necessary to transmit a message is desirable and is disclosed as an “object of the present invention,” neither the claims nor the specification contain any definitive statement that would warrant importing such a limitation into



the claims. *See E-Pass Techs., Inc. v. 3Com Corp.*, 343 F.3d 1364, 1370 (Fed. Cir. 2003) (“The court’s task is not to limit claim language to exclude particular devices because they do not serve a perceived ‘purpose’ of the invention. . . . An invention may possess a number of advantages or purposes, and there is no requirement that every claim directed to that invention be limited to encompass all of them.”) (footnote omitted); *see also Howmedica Osteonics Corp. v. Wright Med. Tech., Inc.*, 540 F.3d 1337, 1345 (Fed. Cir. 2008) (discussing *E-Pass*). Defendants’ proposals of “requir[ing] less data to transmit” are therefore hereby expressly rejected.

Finally, Claims 8 and 12 of the ‘506 Patent recite “message codes . . . assigned to the canned messages” and “response codes . . . assigned to the canned multiple response options,” as quoted above. Defendants’ proposals of “code that is assigned to a canned message” and “code that is assigned to a canned response” are therefore hereby expressly rejected as redundant and unnecessary.

The Court having expressly rejected Defendants’ proposed constructions, and the parties having agreed at the March 7, 2014 hearing that a “message code” is something that corresponds to a “canned message,” as noted above, no further construction is necessary. *See U.S. Surgical*, 103 F.3d at 1568; *see also O2 Micro*, 521 F.3d at 1362; *Finjan*, 626 F.3d at 1207. The Court therefore hereby construes the disputed terms as set forth in the following chart:

<u>Term</u>	<u>Construction</u>
“message code”	<b>Plain meaning</b>
“response code”	<b>Plain meaning</b>

### **CONSTRUCTION OF DISPUTED TERMS IN U.S. PATENT NO. 5,915,210**

The '210 Patent is titled "Method and System for Providing Multicarrier Simulcast Transmission." The '210 Patent issued on June 22, 1999, and bears a filing date of July 24, 1997. The '210 Patent is a continuation of a continuation of the '403 Patent. The Abstract of the '210 Patent states:

A two-way communication system for communication between a system network and a mobile unit. The system network includes a plurality of base transmitters and base receivers include[d] in the network. The base transmitters are divided into zonal assignments and broadcast in simulcast using multi-carrier modulation techniques. The system network controls the base transmitters to broadcast in simulcast during both systemwide and zone boundaries to maximize information throughout [sic, throughput]. The preferred mobile unit include[s] a noise detector circuit to prevent unwanted transmissions. The system network further provides an adaptive registration feature for mobile units which controls the registration operation by the mobile units to maximize information throughout [sic, throughput].

Disputed terms appearing in the '210 Patent also appear in other patents-in-suit and have been addressed in the discussion sections corresponding to those other patents-in-suit, namely the '403 Patent and the '946 Patent. As noted above, the parties' briefing, as well as their arguments at the March 7, 2014 hearing, have indicated that the parties agree that disputed claim terms appearing in more than one patent should be given the same meaning for all such patents.

### **CONCLUSION**

The Court adopts the constructions set forth in this opinion for the disputed terms of the patents-in-suit.

The parties are ordered that they may not refer, directly or indirectly, to each other's claim construction positions in the presence of the jury. Likewise, the parties are ordered to refrain from mentioning any portion of this opinion, other than the actual definitions adopted by

the Court, in the presence of the jury. Any reference to claim construction proceedings is limited to informing the jury of the definitions adopted by the Court.

**APPENDIX A**

<b>U.S. Patent No. 5,590,403</b>	
<u>Term</u>	<u>Parties' Agreement</u>
“zone[s]”	“portion[s] of a region of space”
“plurality of transmitters”	“at least two transmitters”
“plurality of base transmitters”	“at least two base transmitters”
“plurality of zones”	“at least two zones”
<b>U.S. Patent No. 5,659,891</b>	
<u>Term</u>	<u>Parties' Agreement</u>
“single mask-defined, bandlimited channel”	“a channel confined to a frequency range”
<b>U.S. Patent No. 5,754,946</b>	
<u>Term</u>	<u>Parties' Agreement</u>
“means for receiving said specified portion retransmitted from the communications network and for displaying the received specified portion on the display”  (Claim 1)	Function: “receiving said specified portion retransmitted from the communications network and displaying the received specified portion on the display”  Structure: “receiver 1506, display 1514; and equivalents thereof” <sup>9</sup>
“means for transmitting radio frequency signals containing a message to the mobile unit”  (Claim 7)	Function: “transmitting radio frequency signals containing a message to the mobile unit”  Structure: “base transmitter 612, base transmitter 614, base transmitter 1300, or base transmitter 1400; and equivalents thereof”

<sup>9</sup> In accordance with this Court’s standard practice, the Court includes “equivalents” as part of the corresponding structure for means-plus-function terms. See 35 U.S.C. § 112(f).

<p>“means for receiving, from the mobile unit, radio frequency signals representing a portion of the message that the user desires retransmission”</p> <p>(Claim 7)</p>	<p>Function: “receiving, from the mobile unit, radio frequency signals representing a portion of the message that the user desires retransmission”</p> <p>Structure: “base receiver 628; base receiver 630; base receiver 632; base receiver 634; analog base receiver (FIG. 18(A)); digital base receiver (FIG. 18(B)); or base receiver (FIG. 19); and equivalents thereof”</p>
<p><b>U.S. Patent No. 5,786,748</b></p>	
<p>No agreed terms</p>	
<p><b>U.S. Patent No. 5,809,428</b></p>	
<p><u>Term</u></p>	<p><u>Parties’ Agreement</u></p>
<p>“means for transmitting messages to the mobile unit”</p> <p>(Claim 1)</p>	<p>Function: “transmitting messages to the mobile unit”</p> <p>Structure: “message transmitting unit 108; and equivalents thereof”</p>
<p>“means for receiving acknowledgment messages from the mobile unit”</p> <p>(Claim 1)</p>	<p>Function: “receiving acknowledgment messages from the mobile unit”</p> <p>Structure: “message receiving unit 104; and equivalents thereof”</p>
<p>“means for transmitting a probe message to the mobile unit if, after transmitting a data message to the mobile unit, no data acknowledgment is received”</p> <p>(Claim 1)</p>	<p>Function: “transmitting a probe message to the mobile unit if, after transmitting a data message to the mobile unit, no data acknowledgment is received”</p> <p>Structure: “message transmitting unit 108; and equivalents thereof”</p>

<p>“means for receiving registration messages from the mobile unit”  (Claim 2)</p>	<p>Function: “receiving registration messages from the mobile unit”  Structure: “message receiving unit 104; and equivalents thereof”</p>
<p>“means for receiving data and probe messages from the network operations center”  (Claim 4)</p>	<p>Function: “receiving data and probe messages from the network operations center”  Structure: “receiver 204; and equivalents thereof”</p>
<p><b>U.S. Patent No. 5,894,506</b></p>	
<p><u>Term</u></p>	<p><u>Parties’ Agreement</u></p>
<p>“means for retrieving the file of canned messages and the file of canned multiple response options from the memory”  (Claim 19)</p>	<p>Function: “retrieving the file of canned messages and the file of canned multiple response options from the memory”  Structure: “CPU 110, ROM 112 (including stored application program for controlling terminal operation), and system bus 130 (which interconnects system components such as CPU 110, ROM 112, and RAM 114); and equivalents thereof”</p>
<p>“means for selecting one of the canned messages and at least one of the multiple response options appropriate for the selected canned message for communication to a designated other message terminal”  (Claim 19)</p>	<p>Function: “selecting one of the canned messages and at least one of the multiple response options appropriate for the selected canned message for communication to a designated other message terminal”  Structure: “terminal keypad 126; or a mouse; or a cursor; and equivalents thereof”</p>

<p>“means for retrieving the file of canned messages and message codes from the memory”</p> <p>(Claim 21)</p>	<p>Function: “retrieving the file of canned messages and message codes from the memory”</p> <p>Structure: “CPU 110, ROM 112 (including stored application program for controlling terminal operation), and system bus 130 (which interconnects system components such as CPU 110, ROM 112, and RAM 114); and equivalents thereof”</p>
<p>“means for selecting one of the canned messages for communication to a designated other message terminal and for selecting multiple response options appropriate for the selected canned message”</p> <p>(Claim 21)</p>	<p>Function: “selecting one of the canned messages for communication to a designated other message terminal and for selecting multiple response options appropriate for the selected canned message”</p> <p>Structure: “terminal keypad 126; or a mouse; or a cursor; and equivalents thereof”</p>
<p><b>U.S. Patent No. 5,915,210</b></p>	
<p><u>Term</u></p>	<p><u>Parties’ Agreement</u></p>
<p>“plurality of carrier signals”</p> <p>(Claims 1, 10 &amp; 19)</p>	<p>“at least two carrier signals”</p>

Dkt. No. 107 at App’x 1; Dkt. No. 116 at Ex. A.

**UNITED STATES DISTRICT COURT  
FOR THE EASTERN DISTRICT OF TEXAS  
MARSHALL DIVISION**

MOBILE TELECOMMUNICATIONS TECHNOLOGIES, LLC,  v.  SPRINT NEXTEL CORP.	§ § § § § § §	Case No. 2:12-cv-832-JRG-RSP
SAMSUNG TELECOMMUNICATIONS AMERICA, LLC	§ §	Case No. 2:13-cv-259-JRG-RSP
APPLE, INC.	§	Case No. 2:13-cv-258-JRG-RSP

**MTEL'S OPENING CLAIM CONSTRUCTION BRIEF**



**TABLE OF CONTENTS**

I. INTRODUCTION ..... 1

II. STANDARDS OF CLAIM CONSTRUCTION..... 1

III. OVERVIEW OF THE PATENTS-IN-SUIT ..... 2

    A. The Inventions Described and Claimed in the '428 Patent..... 3

    B. The Inventions Described and Claimed in the '946 Patent..... 3

    C. The Inventions Described and Claimed in the '891 Patent..... 4

    D. The Inventions Described and Claimed in the '506 Patent..... 5

    E. The Inventions Described and Claimed in the '403 Patent..... 6

    F. The Inventions Described and Claimed in the '210 Patent..... 7

IV. THE CLAIM TERMS AT ISSUE ..... 8

    A. Most of the Claim Terms Use their Plain and Ordinary Meanings. .... 8

    B. Terms Requiring Construction..... 16

    C. Terms that Defendants Claim are Indefinite..... 20

V. CONSTRUCTIONS OF MEANS-PLUS-FUNCTION TERMS SHOULD INCLUDE  
    “AND EQUIVALENTS.” ..... 27

VI. CONCLUSION..... 27

**TABLE OF AUTHORITIES**

FEDERAL CASE	PAGE(S)
<i>ACS Hosp. Sys., Inc. v. Montefiore Hosp.</i> , 732 F.2d 1572 (Fed. Cir. 1984).....	20
<i>Brown v. 3M</i> , 265 F.3d 1349, 1352 (Fed. Cir. 2001).....	13
<i>Cent. Admixture Pharmacy Servs., Inc. v. Advanced Cardiac Solutions, P.C.</i> , 482 F.3d 1347 (Fed. Cir. 2007).....	19
<i>CVI/Beta Ventures, Inc. v. Tura LP</i> , 112 F.3d 1146 (Fed. Cir. 1997).....	21, 22
<i>EON Corp. IP Holdings, LLC v. T-Mobile USA, Inc.</i> , Nos. 6:10-cv-0379 .....	26
<i>Elan Microelectronics Corp. v. Pixcir Microelectronics Co. Ltd.</i> , 2013 U.S. Dist. LEXIS 76983 (D. Nev. May 30, 2013).....	23
<i>Home Diagnostics, Inc. v. LifeScan, Inc.</i> , 381 F.3d 1352 (Fed. Cir. 2004).....	16
<i>Honeywell Int’l, Inc. v. Acer America Corp.</i> , No. 6:07-cv-125, 2009 WL 68896 (E.D. Tex. Jan. 7, 2009) .....	15
<i>i2 Techs., Inc. v. Oracle Corp.</i> , 2011 WL 209692 (E.D. Tex. Jan. 21, 2011).....	2
<i>In re Aoyama</i> , 656 F.3d 1293 (Fed. Cir. 2011).....	21
<i>Intellectual Property Dev., Inc. v. UA-Columbia Cablevision of Westchester, Inc.</i> , 336 F.3d 1308 (Fed. Cir. 2003).....	19
<i>Johnson Worldwide Assocs. v. Zebco Corp.</i> , 175 F.3d 985, 990 (Fed. Cir. 1999).....	13
<i>Key Pharms. v. Hercon Labs. Corp.</i> , 161 F.3d 709 (Fed. Cir. 1998).....	19
<i>Lisle Corp. v. A.J. Mfg. Co.</i> , 398 F.3d 1306 (Fed. Cir. 2005).....	19
<i>McCarty v. Lehigh Valley R.R. Co.</i> , 160 U.S. 110, 116 (U.S. 1895).....	13
<i>Micro Chem, Inc. v. Great Plains Chem. Co., Inc.</i> , 194 F.3d 1250 (Fed. Cir. 1999).....	20

*Motorola Mobility, Inc. v. Tivo, Inc.*,  
No. 5:11-cv-53-JRG, 2012 WL 6087792 (E.D. Tex. 2012) .....26

*MTel, LLC v. Clearwire Corp.*,  
No. 2:12-cv-308-JRG-RSP, 2013 WL 3339050 (E.D. Tex. July 1, 2013) (the  
“Clearwire Order”) .....13, 14, 15

*Nikon Corp. v. ASM Lithography B.V.*,  
308 F.Supp.2d 1039 (N.D. Cal. 2004) .....8

*Omega Eng'g, Inc. v. Raytek Corp.*,  
334 F.3d 1314 (Fed. Cir. 2003).....14

*Phillips v. AWH Corp.*, 415 F.3d 1303, 1323 (Fed. Cir. 2005) .....8

*Software Tree, LLC v. Redhat, Inc.*, No. 6:09-cv-097, 2010 WL 2232809, at \*8 (E.D.  
Tex. June 1, 2010).....14

*Software Tree, LLC v. Redhat, Inc.*, No. 6:09-cv-097, 2010 WL 2232809, at \*8 (E.D.  
Tex. June 1, 2010).....9

*TecSec, Inc. v. IBM*,  
731 F.3d 1336 (Fed. Cir. 2013).....24

*Telcordia Techs., Inc. v. Cisco Sys., Inc.*,  
612 F.3d 1365 (Fed. Cir. 2010).....23

*Teleflex, Inc. v. Ficosa North America Corp.*,  
299 F.3d 1313 (Fed. Cir. 2002).....12

*Thorner v. Sony Computer Entertainment America LLC*,  
2012 WL 280657 (Fed. Cir. 2012).....13

*U.S. Surgical Corp. v. Ethicon, Inc.*, 103 F.3d 1554, 1568 (Fed. Cir. 1997).....12

*United Video Props. v. Amazon.com, Inc.*,  
2012 U.S. Dist. LEXIS 86914 (D. Del. June 22, 2012).....23

*Vitronics Corp. v. Conceptronic, Inc.*, 90 F.3d 1576, 1583 (Fed. Cir. 1996).....14, 19

**FEDERAL STATUTES**

35 U.S.C. § 112 .....20, 24, 26

## **I. INTRODUCTION**

Plaintiff Mobile Telecommunications Technologies, LLC's ("MTel's") proposed constructions for the claim terms of U.S. Patent Nos. 5,809,428 (the "'428 Patent"), 5,754,946 (the "'946 Patent"), 5,894,506 (the "'506 Patent"), 5,590,403 (the "'403 Patent"), 5,659,891 (the "'891 Patent"), 5,915,210 (the "'210 Patent") and 5,786,748 (the "'748 Patent") (collectively, the "Patents-in-Suit") follow the canons prescribed by the Federal Circuit. MTel's constructions are consistent with the intrinsic and extrinsic evidence and provide meanings that the jury will understand. A person having ordinary skill in the art (PHOSITA) at the time each invention was made would have understood MTel's constructions as correct. On the other hand, Defendants' proposed constructions inject structural limitations into the claims, read preferred embodiments out of the claims, and contradict the claim language. Defendants' proposals are contrived to avoid infringement and are otherwise unsupported by black letter law.

## **II. STANDARDS OF CLAIM CONSTRUCTION**

"Claim construction is a matter of resolution of disputed meanings and technical scope, to clarify and when necessary to explain what the patentee covered by the claims, for use in determination of infringement." *U.S. Surgical Corp. v. Ethicon, Inc.*, 103 F.3d 1554, 1568 (Fed. Cir. 1997). The words of a claim are presumed to use their ordinary and customary meaning, which "provides an objective baseline from which to begin claim interpretation." *Phillips v. AWH Corp.*, 415 F.3d 1303, 1312-1313 (Fed. Cir. 2005) ("[a] fundamental maxim is that the words in a claim should be given their ordinary meaning"). The ordinary and customary meaning "is the meaning that the term would have to a PHOSITA at the time of the invention." *Id.* at 1303.

There are only two exceptions to the general rule that claim terms are given their plain and ordinary meanings: "1) when a patentee sets out a definition and acts as his own

lexicographer, or 2) when the patentee disavows the full scope of a claim term either in the specification or during prosecution.” *Thorner v. Sony Computer Entm't Am. LLC*, 669 F.3d 1362, 1365 (Fed. Cir. 2012). The purpose of claim construction is to define the proper scope of the invention and to give meaning to claim language when the jury might otherwise misunderstand a claim term in the context of the patent and its file history.<sup>1</sup> *See, e.g., i2 Techs., Inc. v. Oracle Corp.*, No. 6:09-cv-194, 2011 WL 209692, at \*4 (E.D. Tex. Jan. 21, 2011) (“The plain language of the term is understandable; therefore, [the disputed terms] do not require construction.”). If a claim term is non-technical and derives no special meaning from the patent and its prosecution history, then the Court has no need to function as a thesaurus. *See Brown v. 3M*, 265 F.3d 1349, 1352 (Fed. Cir. 2001) (concluding that non-technical terms of art . . . do not require elaborate interpretation).

### III. OVERVIEW OF THE PATENTS-IN-SUIT

The inventors, Dennis W. Cameron, Walter C. Roehr, Jr., Rade Petrovik, Jai P. Bhagat, Masood Garahi, William D. Hays, and others, filed these patents between November 12, 1992 and February 28, 1997. Each inventor worked at or with Mobile Telecommunications Technologies Corp., in Jackson, MS, the predecessor-in-interest of MTel. The company owned and operated the first commercially available, two-way wireless messaging network in the country, known as the Skytel paging network. Today, the Skytel paging network is still in operation and is used by first responders and medical professionals because of its reliability.

The '428 Patent incorporates by reference the entirety of the '946 Patent ('428 at [1:39]). The '946 Patent is a continuation-in-part (CIP) of U.S. Patent. No. 5,590,403.

---

<sup>1</sup> Peter S. Menell et al., *Patent Case Management Judicial Guide*, Chapter 5, Section 5.1.4.3. at p. 5-31 (2nd ed. 2012) (“Not All Terms Require Construction”).

**A. The Inventions Described and Claimed in the '428 Patent.**

The '428 Patent teaches a system for reducing the errors that once plagued wireless data communications: undelivered messages. Previously, a mobile unit could only acknowledge that it had accurately received a message. The acknowledgment, however, did not tell the network whether the mobile unit had received: (1) the actual message ("Honey, I'll be home for dinner"); or (2) a probe message (a message sent to determine whether an address can be reached). The '428 Patent enables a mobile unit to distinctively acknowledge whether a successfully delivered message was a data message or a probe message.

Prior to the '428 Patent, messages that could not be delivered immediately might be lost, never to be delivered unless the sender sent the message again. The '428 Patent allows undelivered messages to be stored for processing or delivery later.

**B. The Inventions Described and Claimed in the '946 Patent.**

Mobile units receive messages. Many messages are automatically sent if the mobile unit does not acknowledge receipt of the complete message. This compounds message traffic on the network, reducing capacity and decreasing quality of service. Even still, some errors are not corrected automatically. In addition, sometimes a portion of a message is not received and needs to be resent, refreshed, completed, or updated. '946 Patent at [17:20-21] ("message or a partial message to be retransmitted"). At times, a user may wish to have additional pages of an article, or to open photos or attachments, or to have items updated. The '946 Patent solves these problems while eliminating network congestion (and increasing capacity) due to unnecessary automatically sent messages. The '946 Patent teaches allowing a user to request that the network send the part of the message not previously received. If the user does not request the rest of the message, it is not sent. *Id.* at 17:6-7 ("indicates that the message has not been completely or properly received").

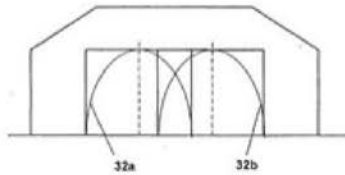
The '946 Patent enables a user to transmit a signal indicating that the mobile unit wants something sent, typically a part of a message that was not received. The network then sends the requested part of the message to the mobile unit. The invention increases efficiency and lowers costs by allowing the user the flexibility to elect not to request transmission of unneeded portions of messages. *Id.* at 17:24-27.

**C. The Inventions Described and Claimed in the '891 Patent.**

The '891 Patent describes and claims methods for operating more than one carrier in a channel to achieve higher capacity at a range of operating parameters, without undue interference protection. '891 at [2:15-25]. Transmissions occur in channels, and multicarrier modulation enables efficient use of limited frequency bandwidth available. To avoid interference caused by signals straying between channels, signals are confined by emissions masks.

The '891 Patent discloses a method that includes operating multiple carriers in a channel using inventive parameters. Specifically, the difference between the center frequency of the outer most carriers within the channel and the edge of the mask that defines the channel has to be more than half the frequency difference between the center frequencies of each adjacent carrier. *Id.* at [4:12-34].

Below, Fig. 3B illustrates a channel defined by a mask. 32a and 32b are overlapping carriers within the channel. The frequency differences between the center frequency of carrier 32a and 32b (the dashed lines) and the nearest band edge of the mask is greater than half the frequency difference between the center frequencies of carriers 32a and 32b. *Id.* at [4:24-34].



**Figure 3B**

**D. The Inventions Described and Claimed in the '506 Patent.**

The inventions of the '506 Patent save time for users and save capacity for networks. '506 at [1:40]. The '506 teaches a way to use symbols, thoughts, and phrases as canned messages. Emoticons are an example: when a smartphone user types a colon and a closed parenthesis (or “:”) the recipient message recipient sees a happy face: ☺.

The '506 Patent teaches the use of a file of canned messages and a corresponding file of message codes. Each canned message is retrievable using its corresponding code. *Id.* at [1:55-57]. The network and the mobile units can each have a file of canned messages and a corresponding file of message codes.

The canned message or code files on a mobile unit may be updated from files stored on the network. That way updated canned message files on the network can be used by all the network users. But files on a network may also be updated from the subscriber terminal (mobile unit). For example, interest groups may have their own customized canned messages. *Id.* at [2:1-6].

Canned messages can accommodate multiple response options. *Id.* at [2:13-27]. For example, a “Calendar” invite is a canned message that can accommodate multiple optional responses; the recipient of a calendar invite can optionally respond with: “accept,” “decline,” “tentative,” or the recipient may be allowed to suggest a time or date. In addition, the canned



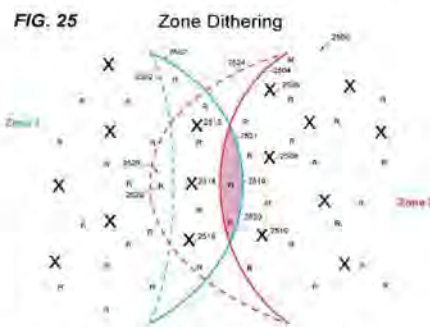
messages may be phrased to accept the addition of one or more parameters, which may be filled in by the sender. A canned message with parameters might be, for example, “Call me at \_\_\_ at (\_\_\_) \_\_\_-\_\_\_\_.” The sending party may want the receiving party to call at “4:00 p.m.” at phone number (512) 512-1212. Thus, the canned message prompts the sending party to fill-in two parameters: time and phone number.

**E. The Inventions Described and Claimed in the '403 Patent.**

The '403 Patent describes and claims methods for transmitting information and communicating messages in a two-way wireless data communication network. '403 at [1:9-14; 33:10-34:63]. One method is to transmit information to a mobile device using two or more sets of transmitters during two or more time periods. *Id.* at [33:10-34: 34]. During the first period, the sets of transmitters transmit in simulcast a block of information, which means they transmit the same information at the same time. Simulcast transmission increases the chances that the information will be received by a mobile device. *Id.* at [4:54-58]. During a second time period, the sets of transmitters transmit different blocks of information. *Id.* at [5:11-28]. The techniques of the '403 Patent increase coverage and throughput. *Id.* at 4:44-48].

The '403 Patent also describes and claims “zone dithering.” Transmitters cover an area

called a “zone.” Fig. 25 (right) shows a blue Zone 1 and a red Zone 2. The transmitters (the Xs 2512, 2514, and 2516) are normally in Zone 1 (shown by the solid blue line), but can instead be assigned to an expanded Zone 2 (dashed red line). Zone dithering is the



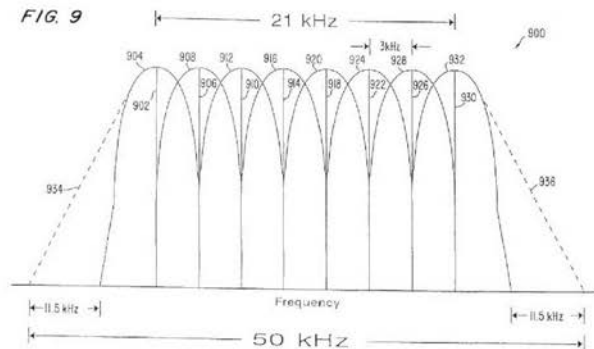
process of assigning transmitters either to Zone 1 or to Zone 2 dynamically to meet the demands for network services. *Id.* at [10-11, 4:60-5:3]. Zone dithering assigns transmitters into zones in

response to the level of mobile data traffic, or in response to interference. *Id.* at [5:65-6:23]. In Fig. 25, the mobile devices (the Rs) that had previously been in an area of interference are shown in purple.

**F. The Inventions Described and Claimed in the '210 Patent.**

The '210 Patent is a continuation of the '403 Patent. The '210 Patent describes and claims transmitting information and communicating messages in a multi-carrier simulcast system. '210 at [5:25-40; 33:45-34:44]. Multi-carrier simultaneous transmission allows for high transmission rates because multiple unique data streams are sent at the same time. *Id.* at [13:3-14; 48-49]. The '210 Patent discloses a system in which a second transmitter simulcasts with a first transmitter, but is spatially separated from the first. *Id.* at [33:56]. Both transmitters generate multiple carrier signals within the selected frequency band—at substantially the same frequencies as each other. *Id.* at [5:25-40].

The '210 Patent Fig. 9 (below) illustrates eight multiple carriers 904 . . . 932, each of which can be modulated to carry a data stream. *Id.* at [13:3-14, 48-49].



IV. THE CLAIM TERMS AT ISSUE<sup>2</sup>

A. Most of the Claim Terms Use their Plain and Ordinary Meanings.

I. “probe message”

Term/Claim	MTel’s Proposal	Apple’s Proposal	Samsung’s Proposal
“probe message” ’428 Patent, Claim 1	No construction necessary; plain and ordinary meaning.	A message sent by the network operation center to locate a mobile unit	Same as Apple

The plain and ordinary meaning of “probe message” is clear from the context of the Claim, which is a message that is sent to determine whether an address can be reached. *See* Exh. 1, Newton’s TeleCom Dictionary, 11th Ed., 481 (1996) (defining “Probe” as “an empty message that is sent to reach a particular address to determine if an address can be reached”). Defendants propose adding “locate,” which improperly imports a limitation from the Specification into the Claims. *See Phillips v. AWH Corp.*, 415 F.3d 1303, 1323 (Fed. Cir. 2005) (“[A]lthough the specification often describes very specific embodiments of the invention, we have repeatedly warned against confining the claims to those embodiments”); *See Nikon Corp. v. ASM Lithography B.V.*, 308 F.Supp.2d 1039, 1088 (N.D. Cal. 2004) (“A ‘cardinal sin of claim construction,’ the Federal Circuit has observed, is to import limitations into claims where claim language permits a construction broader than the embodiments.”). By including “locate,” Defendants improperly combine the functions of the “probe message” and the “probe acknowledge message,” which are parts of separate claim elements and together determine whether the address in the network can be reached. *See* ’428 at [9: 26, 29-31] (“means for

<sup>2</sup> The parties have agreed to the constructions for the terms listed in Appendix A.

transmitting a *probe message* . . . means for determining whether an acknowledgement message is an acknowledgement to a data message or *an acknowledgement to a probe message*”).

Further, Defendants’ proposed construction unnecessarily limits the origin of a message (e.g., “sent by the network operation center”). Where appropriate, the Claims already discloses from where the messages originate. See ’428 at [9:16-19, 26-28] (“a **network operations center** . . . comprising . . . means for **transmitting a probe message to the mobile unit** if, after transmitting a data message to the mobile unit, no data acknowledgment message is received”); See *Software Tree, LLC v. Redhat, Inc.*, No. 6:09-cv-097, 2010 WL 2232809, at \*8 (E.D. Tex. June 1, 2010) (finding claim term clearly understandable to a jury where context explains what it is and what it does); see also *Phillips*, 415 F.3d at 1314 (“[T]he context in which a term is used . . . can be highly instructive.”). Accordingly, construing “probe message” as Defendants request would be an “exercise in redundancy.” *U.S. Surgical Corp.*, 103 F.3d at 1568 (“Claim construction is a matter of resolution of disputed meanings and technical scope, to clarify and when necessary to explain what the patentee covered by the claims. . . . It is not an obligatory exercise in redundancy.”).

**2. “only upon the actuation of the switch” / “only upon receipt of the indication”**

<b>Term/Claim</b>	<b>MTel’s Proposal</b>	<b>Apple’s Proposal</b>	<b>Samsung’s Proposal</b>
“only upon actuation of the switch”  ’946 Patent, Claim 1	No construction necessary; plain and ordinary meaning.	Only upon user actuation of the switch, as opposed to automatically	Same as Apple.
“only upon receipt of the indication”	No construction necessary; plain and ordinary meaning.	Only upon receipt of the indication, as opposed to automatically	Same as Apple.

'946 Patent, Claim 8			
----------------------	--	--	--

These claims do not require construction as there is no material claim construction dispute. *O2 Micro Int'l Ltd. v. Beyond Innovation Tech. Co.*, 521 F.3d 1351, 1361 (Fed. Cir. 2008). MTel does not contend that retransmission occurs automatically without any user involvement. Furthermore, the terms plain and ordinary meanings are clear. “Only upon actuation of the switch” means “not until the switch is put into action.” This meaning is clear from the Claim, which would be easily understandable to the jury without construction. Further, extrinsic evidence supports this plain and ordinary meaning. *See* Exh. 2, Random House Dictionary (1987) (defining “actuate” as “to put into action; start a process; turn on: to actuate a machine.”).

Defendants inject a requirement that “actuation” be “user actuation.” While it is clear that the user must “desire[] retransmission from the communications network” ('946 at [32:2-4]), the patent does not require the user directly actuate the switch. Rather, the user may direct the switch to actuate through a physical (*e.g.*, keyboard, touchscreen, etc.) and/or software (*e.g.*, operating system) based interface. '946 at [17:38-40] (“The request retransmission button 1622 could also be configured in a variety of ways and could be located anywhere on the mobile unit.”). If the patentees wanted to restrict “actuation” to the user actuation, they could have done so in either clause of Claim 1.<sup>3</sup> Defendants’ “as opposed to automatically” limitation is also unnecessary as the claim language makes clear that transmission occurs “only upon” the “actuation of the switch” or the “receipt of the indication.”

<sup>3</sup> Indeed, after many negotiations between the applicant and the USPTO, the applicant proposed the third and final amendment to Claim 1. Applicant added “actuatable to specify a portion of the displayed message for which a user desires retransmission” and deleted “allowing a user to selectively request retransmission of a portion of said message.” Thus, Defendants propose including a limitation specifically withdrawn by the patentees during prosecution. Exh. 3 at 1-2.

3. “canned message”/“canned multiple response options”

Term/Claim	MTel’s Proposal	Apple’s Proposal	Samsung’s Proposal
“canned message” ’506 Patent, Claim 8	No construction necessary; plain and ordinary meaning. <i>In the alternative:</i> a predefined message	Previously stored textual word or phrase	Same as Apple.
“canned multiple response option” ’506 Patent, Claims 12	No construction necessary; plain and ordinary meaning. <i>In the alternative:</i> predefined response messages available for user selection	Previously stored response to canned message	Same as Apple.

A PHOSITA would understand the plain and ordinary meaning of “canned” to be “predefined” and “message” to be “a sequence of characters used to convey information or data.” Exh. 1, Newton’s TeleCom Dictionary, 11th Ed., 373 (1996) (defining “message”). “Response” simply means “an answer to an inquiry.” *Id.* at 510 (1996) (defining “response”). A “canned message” is described in the Specification as “certain messages with an improved degree of message compression.” ’506 at [1:40-41].

Defendants limit a “canned message” to a “textual word or phrase,” but the ’506 Patent does not prohibit a message from being expressed by characters or symbols. Also, by inserting the limitation “previously stored,” Defendants create confusion because the Specification contemplates the canned messages being “updated.” *See, e.g.*, ’506 at [2:1-6] (“In accordance with a feature of the present invention, the . . . canned message files may be updated . . . in order to customize the canned messages according to the needs of a particular group or organization of subscribers.”). The purpose of claim construction is “to clarify, and when necessary to explain

what the patentee covered by the claims,” not introduce unhelpful or confusing language). *U.S. Surgical Corp. v. Ethicon, Inc.*, 103 F.3d 1554, 1568 (Fed. Cir. 1997); *see also Network Appliance Inc. v. Sun Microsystems Inc.*, No. C-07-06053 EDL, 2008 WL 4193049, at \*35-36 (N.D. Cal. Sept. 10, 2008) (rejecting proposed construction that added confusing language). Finally, the storage of responses and canned messages is clear from the claim language itself. *See, e.g.*, ‘506 at [9:58-61] (“maintaining at a network operation center a first file of canned messages and message codes respectively assigned to the canned messages”); ‘506 at [10:53-56] (“maintaining at the network operation center . . . canned multiple response options”).

**4. “code” as used in “message code”/ “response code”**

<b>Term/Claim</b>	<b>MTel’s Proposal</b>	<b>Apple’s Proposal</b>	<b>Samsung’s Proposal</b>
“message code” ‘506 Patent, Claim 8	No construction necessary; plain and ordinary meaning.	Code that is assigned to a canned message that requires less data to transmit than the message itself	Same as Apple.
“response code” ‘506 Patent, Claim 12	No construction necessary; plain and ordinary meaning.	Code that is assigned to a canned response that requires less data to transmit than the response itself	Same as Apple.

“Code” has plain and ordinary meanings that the jury would understand, which is a code for a message/a code for a response. *See Teleflex, Inc. v. Ficosa North America Corp.*, 299 F.3d 1313, 1325 (Fed. Cir. 2002) (internal citation omitted) (“In the absence of an express intent to impart a novel meaning to claim terms, an inventor’s claim terms take on their ordinary meaning.”). The claims do not require that a “code” includes “less data to transmit” than the

“message” or “response.” See *Johnson Worldwide Assocs. v. Zebco Corp.*, 175 F.3d 985, 990 (Fed. Cir. 1999) (“If we once begin to include elements not mentioned in the claim in order to limit such claims . . . , we should never know where to stop.” (citing *McCarty v. Lehigh Valley R.R. Co.*, 160 U.S. 110, 116 (U.S. 1895)). While it is an objective of the invention to transmit “certain messages with an improved degree of message compression” (’506 at [1:41-42]), the claims are not so limited. See, e.g., ’506 at [9:58-61] (“maintaining at a network operation center a first file of canned messages and message codes respectively assigned to the canned messages”); ’506 at [10:53-56] (“maintaining at the network operation center . . . canned multiple response options”).

**5. “transmitter[s]” / “base transmitter[s]”**

Term/Claim	MTel’s Proposal	Apple’s Proposal
“transmitter[s]”/“base transmitter[s]” ’403 Patent, Claims 1, 10, 11 ’891 Patent, Claim 5	No construction necessary; plain and ordinary meaning.	plain and ordinary meaning, with the understanding that the Court has rejected MTel’s implication that transmitting multiple signals or outputs from a single structural unit can suffice as multiple transmitters

The terms “transmitter[s]” and “base transmitter[s]” do not require construction and should be afforded their plain and ordinary meanings, as this Court found in the construction of the ’403 Patent claim terms in *MTel, LLC v. Clearwire Corp.*, No. 2:12-cv-308-JRG-RSP, 2013 WL 3339050, at \*2-3 (E.D. Tex. July 1, 2013) (the “*Clearwire Order*”). See *Thorner v. Sony Computer Entertainment America LLC*, 2012 WL 280657 at \*2 (Fed. Cir. 2012) (holding ordinary meaning should apply unless there is an explicit definition or disavowal). These terms are common and would be easily understood by a jury. See *Brown v. 3M*, 265 F.3d 1349, 1352



(Fed. Cir. 2001) (concluding that non-technical terms of art . . . do not require elaborate interpretation); *Software Tree, LLC v. Redhat, Inc.*, No. 6:09-cv-097, 2010 WL 2232809, at \*8 (E.D. Tex. June 1, 2010) (finding claim term clearly understandable to a jury where context explains what it is and what it does).

Indeed, Defendants acknowledge no construction is necessary by not disputing the presumption of plain and ordinary meaning for the same terms in the '210 Patent (a continuation of the '403 Patent). *See* '210 at Claim 1 [33:50] (emphasis added) (“a first *transmitter* configured”); *Id.* at Claim 10 [34:59-60] (emphasis added) (“transmitting the first plurality of carrier signals from a first *transmitter*”). It is a “fundamental maxim” of claim construction that absent a claim scope dispute, “the words in a claim should be given their ordinary meaning.” *Phillips v. AWH Corp.*, 415 F.3d 1303, 1312-1313 (Fed. Cir. 2005). Because the same terms should be construed the same across related patents, the disputed '403 Patent terms are entitled to their plain and ordinary meaning. *See Omega Eng'g, Inc. v. Raytek Corp.*, 334 F.3d 1314, 1334 (Fed. Cir. 2003) (“[W]e presume, unless otherwise compelled, that the same claim term in the same patent or related patents carries the same construed meaning.”).

Apple’s negative limitation (“the Court has rejected MTel’s implication that transmitting multiple signals or outputs from a single structural unit can suffice as multiple transmitters”) imports out of context dicta from the *Clearwire* Order to read out a preferred embodiment. *See Clearwire* Order at 2-3. A construction that excludes a preferred embodiment “is rarely, if ever, correct.” *Vitronics Corp. v. Conception, Inc.*, 90 F.3d 1576, 1583 (Fed. Cir. 1996). Apple’s construction is a prelude to its non-infringement position—that the accused Airport Extreme is “a single structural unit,” and therefore cannot suffice as multiple transmitters. But the '891 Specification, for example, discloses co-located transmitter systems that can be expanded to

allow for more than two data sources and carriers. '891 Patent at [4:7-11] (emphasis added) (“For example, the *co-located transmitter configurations* discussed above can be expanded to support more than two data sources and transmit more than two carriers in the bandlimited channel.”). Moreover, these limitations contradict the language of Claim 5 of the '891 Patent, which teaches “co-locating said plurality of transmitters such that said plurality of carriers can be emanated from the same transmission source.” '891 Patent at [6:34-37]; *See Honeywell Int'l, Inc. v. Acer America Corp.*, No. 6:07-cv-125, 2009 WL 68896, at \*9 (E.D. Tex. Jan. 7, 2009) (construction that contradicts the claims “must be rejected”). Likewise, Dependent Claim 2 of the '210 Patent (a continuation of the 403 Patent) claims the transmission system of Claim 1 wherein “the first transmitter comprises a plurality of transmitters located in a first area, and the second transmitter comprises a plurality of transmitters located in a second area.” '210 at [33:50-67]. Indeed, this Court already rejected such an interpretation in the *Clearwire*. *See Clearwire* Order at \*3 (“the Court rejects Clearwire’s proposition that a ‘transmitter’ must be spatially separated or geographically dispersed from other transmitters, because Clearwire has provided no evidence to support reading such a limitation into the claims”).

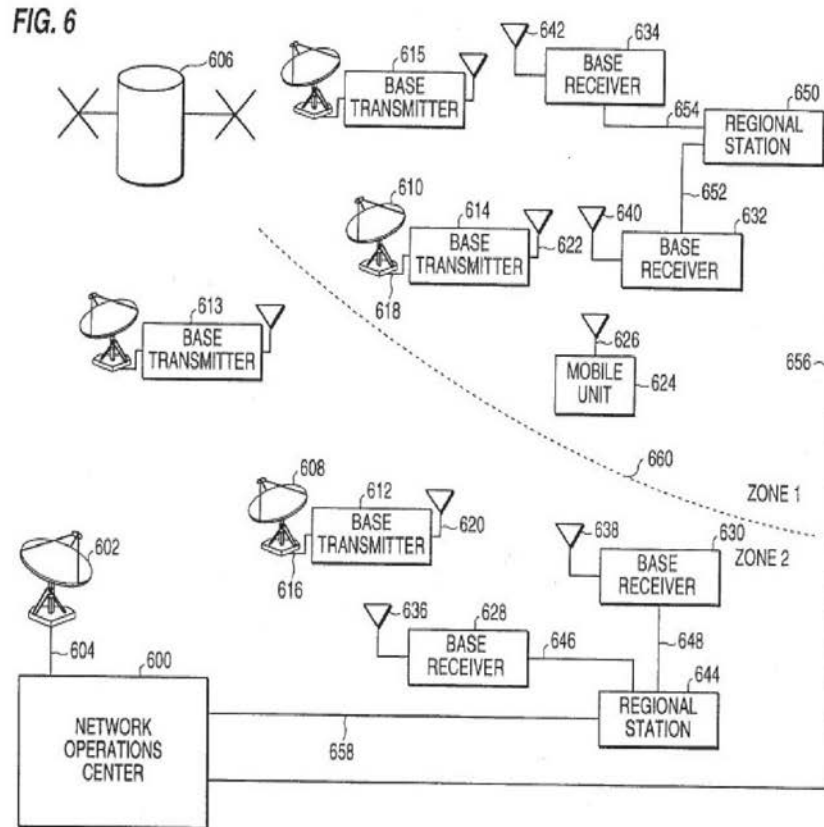
Furthermore, inserting “the Court has rejected MTel’s implication” is improper because it would also prejudice MTel at trial. The jury may doubt MTel’s case when it learns that the Court has already “rejected” MTel’s position.

**B. Terms Requiring Construction.**

**1. “set[s] of transmitters”/ “set of base transmitters”**

Term/Claim	MTel’s Proposal	Apple’s Proposal
“set[s] of transmitters”/“set of base transmitters” ’403 Patent, Claims 1, 10	one or more [base] transmitters	Set[s] of at least two [base] transmitters.

Construing a set of transmitters as one or more transmitters allows the patentees the full scope of the claim language while avoiding confusion that would result if Defendants’ proposal was accepted. *See, e.g., Home Diagnostics, Inc. v. LifeScan, Inc.*, 381 F.3d 1352, 1358 (Fed. Cir. 2004) (“Absent a clear disavowal in the specification or the prosecution history, the patentee is entitled to the full scope of its claim language.”). The terms “set of base transmitters” and “set of transmitters” are used to indicate a logical grouping and not necessarily numerical limitation. *See* Exh. 6, (Webster’s Dictionary) (defining “set” as “number of things of the same kind that belong or are used together”). For instance, Claim 10 at 34:45 discloses “a first set of base transmitters assigned to a first zone.” Here, and as shown in Figure 6 (below), the defining characteristic of this set of base transmitters is zonal assignment to the *first* zone—Zone 1 of Fig. 6.



Adopting Defendants’ numerical limitation, which requires a set to include at least two base transmitters, only confuses matters because Claim 10 already requires at least two base transmitters by virtue of requiring simulcasting *within* each set of base transmitters. ’403 Patent, Claim 10 at 34:44-46 (emphasis added) (“the first information signal being transmitted in simulcast *by* a **first set** of base transmitters **assigned to a first zone**”). This *intra*-set simulcast necessitates the presence of at least two base transmitters because a sole base transmitter cannot “simulcast” with itself. As such, construing the terms as Defendants request would be an “exercise in redundancy.” *U.S. Surgical Corp.*, 103 F.3d at 1568.

On the other hand, Claim 1 uses different terminology and only requires *inter*-set simulcast—simulcast by *the first and a second* sets of transmitters.” ’403 Patent, Claim 1 at 33:22-25(emphasis added) (“transmitting *by* the **first and second set** of transmitters...in simulcast”). Claim 1 is not limited by the requirement to simulcast using transmitters *within* a single set, as is Claim 10. Even if two sets of transmitters each contain only a single transmitter, the simulcast requirement in Claim 1 is still met because a transmitter in a first set can transmit in simulcast with a transmitter in a second set. Moreover, the description of the operation of a preferred embodiment in Figure 6 explicitly discloses *inter*-set simulcasting between two transmitters in two different zones. *See e.g.* ’403 Patent at 10:39-49 (describing Figure 6 and *inter*-set simulcast transmission between base transmitter 614 in zone 1 (*see* 9:47) and base transmitter 612 located in zone 2 (*see* 9:49)).

The Court should adopt MTel’ proposal to construe “set[s] of transmitters”/“set of base transmitters” as “one or more [base] transmitter” because its use is consistent with the ordinary meaning of “set” and results in a coherent read of the Claims.

2. “a portion of the displayed message” / “a portion of a displayed message”/ “a portion of the message.”

Term/Claim	MTel’s Proposal	Apple’s Proposal
“a portion of the displayed message”  ’946 Patent, Claims 1 and 8	Message data associated with a partially received message	Less than the entire displayed message
“a portion of a displayed message”  ’946 Patent, Claim 7		Less than the entire displayed message
“a portion of the message”  ’946 Patent, Claim 1		Less than the entire message

These terms should be construed as “message data associated with a partially received message.” Without construction, the jury may be confused that “portion” cannot mean the entire message as intended by the patentees. Defendants unjustifiably ask to limit the term to “less than the entire message.” But the Specification provides for transmission of the entire message: “[t]he user reads the message and determines whether the displayed message is acceptable. If not, the user can cause the system to **retransmit the message, or the erroneous portions** by pressing request retransmission button 1622.” ’946 at [17:14-17] (emphasis added); *see also* ’946 at [15:39-41] (emphasis added) (“The input switches 1516 also include a switch that allows the user to request **retransmission of a message** corrupted by errors.”). The erroneous part of the message could be the entire message. To be sure, the ’946 Patent contemplates retransmission “of **at least** parts of the message” or “at least portions of the message.” ’946 at [5:13-19] (emphasis added). The words “at least” support embodiments in which the user requests *all* of

the message to be retransmitted. The Court should not read these preferred embodiments out of the Claims. See *Vitronics Corp. v. Conceptoronic, Inc.*, 90 F.3d 1576, 1583 (Fed. Cir. 1996) (interpretation that excludes preferred embodiments is rarely, if ever, correct).

**C. Terms that Defendants Claim are Indefinite.**

Defendants contend that two terms drafted in means-plus-function format are indefinite, but Defendants failed to identify the “functions” that allegedly lack corresponding structure in the Joint Claim Construction Statement. See *Intellectual Property Dev., Inc. v. UA-Columbia Cablevision of Westchester, Inc.*, 336 F.3d 1308, 1319 (Fed. Cir. 2003) (“In construing means-plus-function claim limitations, a court must first define the particular function claimed.”). Defendants thereby have waived any argument that these terms have a function different from those identified by MTel.<sup>4</sup>

A claim is indefinite only if it is “insolubly ambiguous” and not amenable to court construction. *Exxon Res. & Eng'g Co. v. United States*, 265 F.3d 1371, 1375 (Fed. Cir. 2001). The party seeking to invalidate a claim under 35 U.S.C. § 112 ¶ 2 as indefinite must show by clear and convincing evidence that one skilled in the art would not understand the scope of the claim when read in light of the specification. *Intellectual Prop. Dev., Inc. v. UA-Columbia Cablevision of Westchester, Inc.*, 336 F.3d 1308, 1319 (Fed. Cir. 2003). Invalidating a claim for indefiniteness is disfavored, and close questions are resolved in favor of the patentee. See *ACS*

---

<sup>4</sup> Indeed, the Federal Circuit has repeatedly affirmed that district courts are authorized to deem claim construction arguments waived where a party had an opportunity to raise the argument but failed to do so. See *Cent. Admixture Pharmacy Servs., Inc. v. Advanced Cardiac Solutions, P.C.*, 482 F.3d 1347, 1356 (Fed. Cir. 2007) (affirming as within a district court’s discretion a finding that an alleged infringer waived claim construction positions for failing to raise them until after claim construction had been briefed and ordered); *Liste Corp. v. A.J. Mfg. Co.*, 398 F.3d 1306, 1317 (Fed. Cir. 2005) (concluding that the defendant waived its indefiniteness defense); *Key Pharms. v. Hercon Labs. Corp.*, 161 F.3d 709 (Fed. Cir. 1998) (holding that the trial court properly refused to adopt a claim construction position that was contrary to a party’s earlier position).

*Hosp. Sys., Inc. v. Montefiore Hosp.*, 732 F.2d 1572, 1577 (Fed. Cir. 1984) (“[C]laims should be so construed, if possible, as to sustain their validity.”). As the Federal Circuit explains,

[w]e have not insisted that claims be plain on their face in order to avoid condemnation for indefiniteness; rather, what we have asked is that the claims be amenable to construction, however difficult that task may be . . . . If the meaning of the claim is discernible, even though the task may be formidable and the conclusion may be one over which reasonable persons will disagree, we have held the claim sufficiently clear to avoid invalidity on indefiniteness grounds.

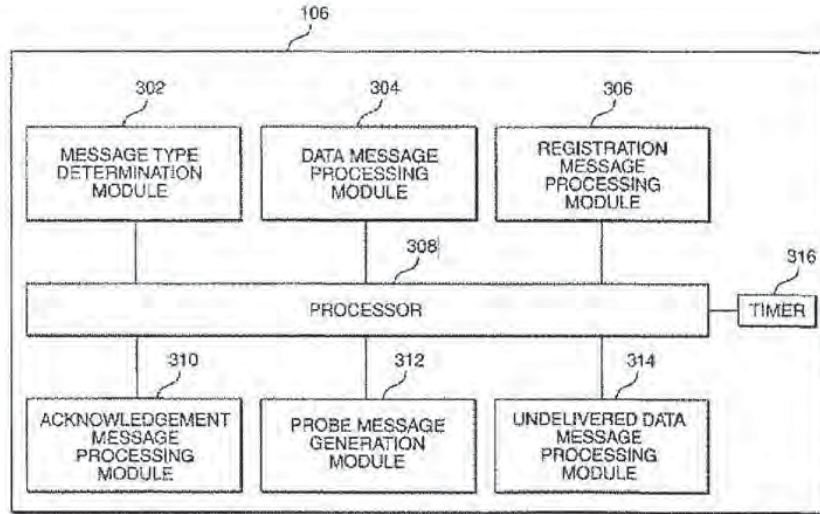
*Exxon Res. & Eng'g Co.*, 265 F.3d at 1375. The Court may not limit a means-plus-function claim “by adopting a function different from that explicitly recited in the claim.” See *Micro Chem, Inc. v. Great Plains Chem. Co., Inc.*, 194 F.3d 1250, 1258 (Fed. Cir. 1999) (warning that an error in identification of the function can improperly alter the identification of the corresponding structure). The corresponding structure does not need to include all necessary elements to enable the claimed invention, but the structure must include all structure that actually performs the recited function. *Id.* Courts consider the entire specification to determine whether the structure that is capable of performing the recited function. *Id.* Here, the Specification describes the requisite structure to perform the claimed functions such that a PHOSITA would understand the bounds of the claim terms and would find the structure capable of performing the functions. *In re Aoyama*, 656 F.3d 1293, 1298 (Fed. Cir. 2011).



1. “Means for Determining” is Definite.

Term/Claim	MTel’s Proposal	Apple’s Proposal	Samsung’s Proposal
means for determining whether an acknowledgment message is an acknowledgment to a data message or an acknowledgment to a probe message [’428 Patent, Claim 1]	<p><u>Function</u> determining whether an acknowledgment message is an acknowledgment to a data message or an acknowledgment to a probe message</p> <p><u>Structure</u> acknowledgment message processing (AMP) module 310, and/or memory 110 and processor 308 and equivalents</p>	Indefinite	Same as Apple.

“Means for determining” is drafted in means-plus-function format and recites the function “determining whether an acknowledgment message is an acknowledgment to a data message or an acknowledgment to a probe message.” Defendants argue this term is indefinite, ignoring the corresponding structure described in the Specification. The ’428 Patent identifies Acknowledgment Message Processing (AMP) module 310 as structure that performs the recited functions. See ’428 at [5:24-28] (emphasis added) (“As AMP module 310 receives an acknowledgment message . . . it first *determines whether the message is a data acknowledgment message or a probe acknowledgment message.*”). The Specification further describes module 310 as either “software or microcode and any hardware” to execute them or “electronic logic circuitry.” ’428 at [5:59-65]. Such hardware may include processor 308, which Figure 3 (below) illustrates as interacting with AMP module 310. See, e.g., *CVI/Beta Ventures, Inc. v. Tura LP*, 112 F.3d 1146, 1153 (Fed. Cir. 1997) (holding patent drawings highly relevant to understanding claims).



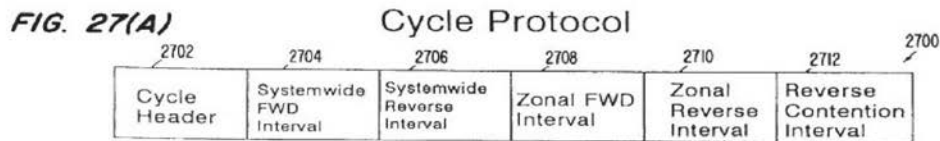
**FIG.3**

The '428 further provides that “[p]rocessor 308 is preferably any processor capable of executing the software or microcode . . . and performing the processing functions.” ‘428 at [5:65-6:1]. In addition, the Specification describes module 310 interacting with memory 110 to perform the claimed function. *Id.* at [5:31-32] (“AMP module 310 updates in memory storage unit 110 the location of mobile unit 200”).

Therefore, the Specification includes definite structure to perform the recited function for this term. *See* Exh. 4, Communications Standard Dictionary (1989) (defining “module” as “a software unit that is discrete and identifiable with respect to compile, load, execute, and other programming functions.”). The function of determining a message type is a function that a general purpose computer (e.g., the module/processor and memory) could perform at the time of the invention because they involve only the general computing tasks of processing (is the message type A or type B?) and checking memory (has a message been stored in memory?). *In re Katz Interactive Call Processing Patent Litig.*, 639 F.3d 1303, 1316 (Fed. Cir. 2011) (structure

for “means for cross-referencing” was general purpose computer because “processing,” “storing,” and “receiving” can be done by “any general purpose computer without special programming”).<sup>5</sup> A PHOSITA would recognize AMP module 310 as capable of determining the difference between a probe acknowledgement and data message acknowledgement “*in accordance with conventional techniques.*” ’428 at [5:62].

A PHOSITA would understand these two types of ACK messages are distinguished by, for example, a header or other field within a transmission packet. The related ’946 Patent, which is incorporated by reference, discloses that acknowledgements are sent using 3 bits. ’946[27:47-53]. Alternatively, the AMP module 310 may determine the ACK type based on *when* it received the ACK. As shown in FIG. 27(A) of the ’946 Patent (below), a probe ACK (with a proper address for a mobile unit) is expected during Systemwide Reverse Interval 2706 while a message ACK may be expected in Zonal Reverse Interval 2710. ’946 at [27:40-47].



Although not required for definiteness, the ’428 Patent provides algorithms that describe how the module, processor, and memory perform the “determining” function. For example, the Specification provides an if-then-else algorithm in prose at 5:24-34. *See TecSec, Inc. v. IBM,*

<sup>5</sup> *Telcordia Techs., Inc. v. Cisco Sys., Inc.*, 612 F.3d 1365, 1376-77 (Fed. Cir. 2010) (holding over objection that “controller circuit [w]as a black box” that “controller” was sufficient disclosure because PHOSITA would have recognized the controller as an electronic device with a known structure”); *Elan Microelectronics Corp. v. Pixcir Microelectronics Co. Ltd.*, 2013 U.S. Dist. LEXIS 76983 \*66 (D. Nev. May 30, 2013) (general purpose computers capable of “detecting a distance between said first and second maxima” so general purpose computer was structure, no algorithm needed.); *United Video Props. v. Amazon.com, Inc.*, 2012 U.S. Dist. LEXIS 86914, \*28 (D. Del. June 22, 2012) (“displaying” an icon is a common function that can be achieved by any general purpose computer without special programming.”).

731 F.3d 1336, 1348 (Fed. Cir. 2013) (an algorithm “in any understandable terms including as a mathematical formula, in prose, or as a flow chart . . . provides sufficient structure.”). A PHOSITA would view this algorithm as sufficient when executed to perform the “determining” function.<sup>6</sup>

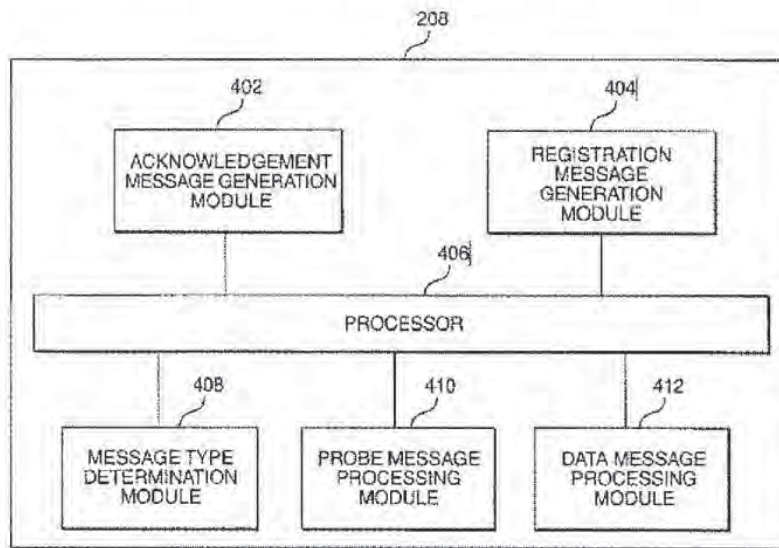
**2. “Means for Generating” is Definite.**

Term/Claim	MTel’s Proposal	Apple’s Proposal	Samsung’s Proposal
means for generating, upon power restoration to the transmitter, a registration message if a probe message has been received while the transmitter was powered off, said registration message being transmitted by said transmitter [ <sup>’428 Patent, Claim 4</sup> ]	<p><u>Function</u> generating, upon power restoration to the transmitter, a registration message if a probe message has been received while the transmitter was powered off, said registration message being transmitted by said transmitter</p> <p><u>Structure</u> registration message generation module 404 and/or memory 212 and processor 406, and equivalents</p>	Indefinite	Same as Apple.

The ’428 Patent identifies the appropriately named registration message *generation* (RMG) module 404 as performing the “generating” function listed above. ’428 at [FIG. 4]. RMG 404 is disclosed as “software or microcode and any hardware necessary to affect the execution of that software of microcode in accordance with conventional techniques.” ’428 at 6:49-52. This disclosure recites structure that a PHOSITA would understand to be capable of

<sup>6</sup> Claim 1 of the original application for the ’428 Patent included this “means for determining whether an acknowledgment message” element. (Exh. 5 at 20). Claim 4 of the original application likewise included the “means for determining whether a probe message” element. (Exh. 5 at 21). During the two-year long patentability examination, PTO Examiner Crosland never questioned the compliance of either clause with 35 USC §112, although it was his job to do so if he had had any doubt.

performing the “generating” functions. *Telcordia Techs., Inc. v. Cisco Sys., Inc.*, 612 F.3d 1365, 1377 (Fed. Cir. 2010) (“specification need only disclose adequate defining structure to render the bounds of the claim understandable to an ordinary artisan”). Fig. 4 (below) discloses that processor 406 accesses and runs software corresponding to RMG module 404. ’428 at [6:4-11; 6:42-48].



**FIG. 4**

Alternatively, the Specification suggests that an artisan could implement these modules using “electronic logic circuitry” at 6:49-54. In either case, to the extent a PHOSITA requires an algorithm, the multiple flowcharts and extended discussions in the ’428 Patent and related patents are more than enough to inform a PHOSITA how to perform the function, and particularly what elements perform each function. See ’428 at [8:42-9:14] and Figs. 9 and 10, depicting the operation of mobile unit 200.

**V. CONSTRUCTIONS OF MEANS-PLUS-FUNCTION TERMS SHOULD INCLUDE “AND EQUIVALENTS.”**

For several terms drafted in means-plus-function format, Defendants dispute MTel’s inclusion of “and equivalents” into the identified structure. It would be helpful to the jury to include this statutory phrase in each relevant construction. It is also commonplace to include this phrase—*Markman* Orders often acknowledge the statutory mandate of 35 U.S.C. §112. *See EON Corp. IP Holdings, LLC v. T-Mobile USA, Inc.*, Nos. 6:10-cv-0379 LED-JDL, 6:11-cv-0015 LED-JDL, 2012 WL 3073432, at \*5 (E.D. Tex. Feb. 8, 2012) (emphasis added) (“Thus, the Court finds that the structure that performs the function of ‘selecting a communication path within said network/communication path’ is ‘electronic switch 13’ *and equivalents*.”); *see also Motorola Mobility, Inc. v. Tivo, Inc.*, No. 5:11-cv-53-JRG, 2012 WL 6087792, at \*23 (E.D. Tex. 2012) (“The Court therefore hereby finds that the term “means for maintaining the level of fullness of the input and output . . . and that the corresponding structure is “Control Management Device 14 . . . and equivalents thereof.”).

**VI. CONCLUSION**

For the reasons stated above, MTel’s proposed constructions should be adopted in their entirety.

Dated: February 6, 2014

Respectfully Submitted,

/s/ Mark W. Halderman

Daniel R. Scardino  
Texas State Bar No. 24033165  
Craig S. Jepson  
Texas State Bar No. 24061364  
Jason W. Deats  
Texas State Bar No. 24036455  
Henning Schmidt  
Texas State Bar No. 24060569  
Mark W. Halderman  
Texas State Bar No. 24077403  
Dustin L. Taylor  
Texas State Bar No. 24088510  
**REED & SCARDINO LLP**  
301 Congress Avenue, Suite 1250  
Austin, TX 78701  
Tel. (512) 474-2449  
Fax (512) 474-2622  
dscardino@reedscardino.com  
cjepson@reedscardino.com  
jdeats@reedscardino.com  
hschmidt@reedscardino.com  
mhalderman@reedscardino.com  
dtaylor@reedscardino.com

Deron Dacus  
Texas Bar No. 00790553  
**THE DACUS FIRM, P.C.**  
821 ESE Loop 323, Suite 430  
Tyler, Texas 75701  
903-705-1117 (phone & fax)  
ddacus@dacusfirm.com

**ATTORNEYS FOR PLAINTIFF  
MOBILE TELECOMMUNICATIONS  
TECHNOLOGIES, LLC**

**CERTIFICATE OF SERVICE**

The undersigned certifies that on this 6th day of February, 2014, all counsel of record who are deemed to have consented to electronic service are being served with a copy of this document through the Court's CM/ECF system under Local Rule CV-5(a)(3).

/s/ Mark W. Halderman

Mark W. Halderman

**US District Court Civil Docket**

U.S. District - Texas Eastern  
(Marshall)

**2:13cv258**

**Mobile Telecommunications Technologies, Llc v. Apple, Inc.**

This case was retrieved from the court on Tuesday, June 03, 2014

Date Filed: **04/02/2013**  
Assigned To: **Judge Rodney Gilstrap**  
Referred To: **Magistrate Judge Roy S. Payne**  
Nature of suit: **Patent (830)**  
Cause: **Patent Infringement**  
Lead Docket: **2:12cv00832**  
Other Docket: **2:13cv00832**  
**2:13cv00886**  
**2:13cv00883**  
**2:13cv00946**  
**2:13cv00885**  
**2:13cv00947**  
**2:13cv00948**  
Jurisdiction: **Federal Question**  
Class Code: **OPEN**  
Closed:  
Statute: **35:271**  
Jury Demand: **Both**  
Demand Amount: **\$0**  
NOS Description: **Patent**

Litigants	Attorneys
Mobile Telecommunications Technologies Llc Plaintiff	<p><a href="#">Anthony D'Ascenzo Seach</a> ATTORNEY TO BE NOTICED <a href="#">Reed &amp; Scardino LLP</a> 301 Congress Ave Ste 1250 Austin , TX 78701 USA 512-474-2449 Fax: 512-474-2622 Email: Aseach@reedscardino.Com</p> <p><a href="#">Craig Steven Jepson</a> ATTORNEY TO BE NOTICED <a href="#">Reed &amp; Scardino LLP</a> 301 Congress Ave Ste 1250 Austin , TX 78701 USA 512-615-5787 Fax: 512-474-2622 Email: Cjepson@reedscardino.Com</p> <p><a href="#">Deron R Dacus</a> ATTORNEY TO BE NOTICED <a href="#">The Dacus Firm, PC</a> 821 Ese Loop 323 Suite 430 Tyler , TX 75701 USA 903/705-1117 Fax: 9037051117 Email: Ddacus@dacusfirm.Com</p> <p><a href="#">Henning Schmidt</a> ATTORNEY TO BE NOTICED</p>



[Reed & Scardino LLP](#)  
301 Congress Ave  
Ste 1250  
Austin , TX 78701  
USA  
512-615-5473  
Fax: 512-474-2622  
Email:Hschmidt@reedscardino.Com

[John Lawrence Hendricks](#)  
ATTORNEY TO BE NOTICED  
[Farney Daniels, PC - Dallas](#)  
8401 N. Central Expressway Suite 280  
Dallas , TX 75225  
USA  
972-432-5780  
Fax: 972-432-5781  
Email:Jhendricks@reedscardino.Com

[Joshua Gabriel Jones](#)  
ATTORNEY TO BE NOTICED  
[Reed & Scardino LLP](#)  
301 Congress Ave  
Ste 1250  
Austin , TX 78701  
USA  
512-615-5474  
Email:Jjones@reedscardino.Com

[Mark W Halderman](#)  
ATTORNEY TO BE NOTICED  
[Reed & Scardino LLP](#)  
301 Congress Ave  
Ste 1250  
Austin , TX 78701  
USA  
512-474-2449  
Fax: 512-474-2622  
Email:Mhalderman@reedscardino.Com

[Steven Tepera](#)  
ATTORNEY TO BE NOTICED  
[Reed & Scardino LLP](#)  
301 Congress Ave  
Ste 1250  
Austin , TX 78701  
USA  
512-474-2449  
Fax: 512-474-2622  
Email:Stepera@reedscardino.Com

[Daniel Scardino](#)  
ATTORNEY TO BE NOTICED  
[Reed & Scardino LLP](#)  
301 Congress Ave  
Ste 1250  
Austin , TX 78701  
USA  
512-474-2449  
Fax: 512-474-2622  
Email:Dscardino@reedscardino.Com

[Brian E Ferguson](#)  
LEAD ATTORNEY;ATTORNEY TO BE NOTICED  
[Weil, Gotshal & Manges LLP-Washington](#)  
1300 Eye St, Nw Suite 900  
Washington , DC 20005-3314  
USA  
202-682-7516  
Fax: 202-857-0940  
Email:Brian.Ferguson@weil.Com

Apple Inc  
Defendant

[Garland T Stephens](#)  
LEAD ATTORNEY; ATTORNEY TO BE NOTICED  
[Weil Gotshal & Manges LLP - Houston](#)  
700 Louisiana, Suite 1700  
Houston, TX 77002  
USA  
713-546-5011  
Fax: 713-224-9511  
Email: Garland.Stephens@weil.Com

[Anish R Desai](#)  
ATTORNEY TO BE NOTICED  
[Weil, Gotshal & Manges LLP - Washington](#)  
1300 Eye St, Nw Suite 900  
Washington, DC 20005-3314  
USA  
202.682.7500  
Fax: 202.857.0940  
Email: Anish.Desai@weil.Com

[Anne Marie Cappella](#)  
ATTORNEY TO BE NOTICED  
[Weil Gotshal & Manges, LLP - Redwood Shores](#)  
201 Redwood Shores Parkway 5th Floor  
Redwood City, CA 94065  
USA  
650-802-3141  
Fax: 650-802-3100  
Email: Anne.Cappella@weil.Com

[Brian Chang](#)  
ATTORNEY TO BE NOTICED  
[Weil Gotshal & Manges, LLP - Redwood Shores](#)  
201 Redwood Shores Parkway 5th Floor  
Redwood Shores, CA 94065  
USA  
650/802-3000  
Fax: 650/802-3100  
Email: Brian.Chang@weil.Com

[Christopher T Marando](#)  
ATTORNEY TO BE NOTICED  
[Weil, Gotshal & Manges LLP - Washington](#)  
1300 Eye St, Nw Suite 900  
Washington, DC 20005-3314  
USA  
202/682-7500  
Fax: 202/857-0940  
Email: Christopher.Marando@weil.Com

[David M DesRosier](#)  
ATTORNEY TO BE NOTICED  
[Weil, Gotshal & Manges LLP - Washington](#)  
1300 Eye St, Nw Suite 900  
Washington, DC 20005-3314  
USA  
202.682.7500  
Fax: 202.857.0940  
Email: David.Desrosier@weil.Com

[Eric Hugh Findlay](#)  
ATTORNEY TO BE NOTICED  
[Findlay Craft PC](#)  
102 N College Avenue Suite 900  
Tyler, TX 75702  
USA  
903/534-1100  
Fax: 903/534-1137  
Email: Efindlay@findlaycraft.Com

[Jill Jane Schmidt](#)  
ATTORNEY TO BE NOTICED

Apple Inc  
Counter Claimant

[Weil Gotshal & Manges, LLP - Redwood Shores](#)  
201 Redwood Shores Parkway 5th Floor  
Redwood City , CA 94065  
USA  
650-802-3000  
Fax: 650-802-3100  
Email:Jill.Schmidt@weil.Com

[Roger Brian Craft](#)  
ATTORNEY TO BE NOTICED  
[Findlay Craft PC](#)  
102 N College Avenue Suite 900  
Tyler , TX 75702  
USA  
903/534-1100  
Fax: 903/534-1137  
Email:Bcraft@findlaycraft.Com

[Brian E Ferguson](#)  
LEAD ATTORNEY;ATTORNEY TO BE NOTICED  
[Weil, Gotshal & Manges LLP-Washington](#)  
1300 Eye St, Nw Suite 900  
Washington , DC 20005-3314  
USA  
202-682-7516  
Fax: 202-857-0940  
Email:Brian.Ferguson@weil.Com

[Garland T Stephens](#)  
LEAD ATTORNEY;ATTORNEY TO BE NOTICED  
[Weil Gotshal & Manges LLP - Houston](#)  
700 Louisiana, Suite 1700  
Houston , TX 77002  
USA  
713-546-5011  
Fax: 713-224-9511  
Email:Garland.Stephens@weil.Com

[Anish R Desai](#)  
ATTORNEY TO BE NOTICED  
[Weil, Gotshal & Manges LLP-Washington](#)  
1300 Eye St, Nw Suite 900  
Washington , DC 20005-3314  
USA  
202.682.7500  
Fax: 202.857.0940  
Email:Anish.Desai@weil.Com

[Anne Marie Cappella](#)  
ATTORNEY TO BE NOTICED  
[Weil Gotshal & Manges, LLP - Redwood Shores](#)  
201 Redwood Shores Parkway 5th Floor  
Redwood City , CA 94065  
USA  
650-802-3141  
Fax: 650-802-3100  
Email:Anne.Cappella@weil.Com

[Christopher T Marando](#)  
ATTORNEY TO BE NOTICED  
[Weil, Gotshal & Manges LLP-Washington](#)  
1300 Eye St, Nw Suite 900  
Washington , DC 20005-3314  
USA  
202/682-7500  
Fax: 202/857-0940  
Email:Christopher.Marando@weil.Com

[David M DesRosier](#)  
ATTORNEY TO BE NOTICED  
[Weil, Gotshal & Manges LLP-Washington](#)  
1300 Eye St, Nw Suite 900

Washington , DC 20005-3314  
USA  
202.682.7500  
Fax: 202.857.0940  
Email: David.Desrosier@weil.Com

[Eric Hugh Findlay](#)  
ATTORNEY TO BE NOTICED  
[Findlay Craft PC](#)  
102 N College Avenue Suite 900  
Tyler , TX 75702  
USA  
903/534-1100  
Fax: 903/534-1137  
Email: Efindlay@findlaycraft.Com

[Jill Jane Schmidt](#)  
ATTORNEY TO BE NOTICED  
[Weil Gotshal & Manges, LLP - Redwood Shores](#)  
201 Redwood Shores Parkway 5th Floor  
Redwood City , CA 94065  
USA  
650-802-3000  
Fax: 650-802-3100  
Email: Jill.Schmidt@weil.Com

[Roger Brian Craft](#)  
ATTORNEY TO BE NOTICED  
[Findlay Craft PC](#)  
102 N College Avenue Suite 900  
Tyler , TX 75702  
USA  
903/534-1100  
Fax: 903/534-1137  
Email: Bcraft@findlaycraft.Com

Mobile Telecommunications Technologies Llc  
Counter Defendant

[Craig Steven Jepson](#)  
ATTORNEY TO BE NOTICED  
[Reed & Scardino LLP](#)  
301 Congress Ave  
Ste 1250  
Austin , TX 78701  
USA  
512-615-5787  
Fax: 512-474-2622  
Email: Cjepson@reedscardino.Com

[Deron R Dacus](#)  
ATTORNEY TO BE NOTICED  
[The Dacus Firm, PC](#)  
821 Ese Loop 323 Suite 430  
Tyler , TX 75701  
USA  
903/705-1117  
Fax: 9037051117  
Email: Ddacus@dacusfirm.Com

[Henning Schmidt](#)  
ATTORNEY TO BE NOTICED  
[Reed & Scardino LLP](#)  
301 Congress Ave  
Ste 1250  
Austin , TX 78701  
USA  
512-615-5473  
Fax: 512-474-2622  
Email: Hschmidt@reedscardino.Com

[John Lawrence Hendricks](#)  
ATTORNEY TO BE NOTICED  
[Farney Daniels, PC - Dallas](#)  
8401 N. Central Expressway Suite 280

Dallas , TX 75225  
USA  
972-432-5780  
Fax: 972-432-5781  
Email: Jhendricks@reedscardino.Com

Mark W Halderman  
ATTORNEY TO BE NOTICED  
Reed & Scardino LLP  
301 Congress Ave  
Ste 1250  
Austin , TX 78701  
USA  
512-474-2449  
Fax: 512-474-2622  
Email: Mhalderman@reedscardino.Com

Steven Tepera  
ATTORNEY TO BE NOTICED  
Reed & Scardino LLP  
301 Congress Ave  
Ste 1250  
Austin , TX 78701  
USA  
512-474-2449  
Fax: 512-474-2622  
Email: Stepera@reedscardino.Com

Daniel Scardino  
ATTORNEY TO BE NOTICED  
Reed & Scardino LLP  
301 Congress Ave  
Ste 1250  
Austin , TX 78701  
USA  
512-474-2449  
Fax: 512-474-2622  
Email: Dscardino@reedscardino.Com

Apple Inc  
Counter Claimant

Brian E Ferguson  
LEAD ATTORNEY; ATTORNEY TO BE NOTICED  
Weil, Gotshal & Manges LLP-Washington  
1300 Eye St, Nw Suite 900  
Washington , DC 20005-3314  
USA  
202-682-7516  
Fax: 202-857-0940  
Email: Brian.Ferguson@weil.Com

Garland T Stephens  
LEAD ATTORNEY; ATTORNEY TO BE NOTICED  
Weil Gotshal & Manges LLP - Houston  
700 Louisiana, Suite 1700  
Houston , TX 77002  
USA  
713-546-5011  
Fax: 713-224-9511  
Email: Garland.Stephens@weil.Com

Anish R Desai  
ATTORNEY TO BE NOTICED  
Weil, Gotshal & Manges LLP-Washington  
1300 Eye St, Nw Suite 900  
Washington , DC 20005-3314  
USA  
202.682.7500  
Fax: 202.857.0940  
Email: Anish.Desai@weil.Com

Anne Marie Cappella  
ATTORNEY TO BE NOTICED

Weil Gotshal & Manges, LLP - Redwood Shores  
201 Redwood Shores Parkway 5th Floor  
Redwood City , CA 94065  
USA  
650-802-3141  
Fax: 650-802-3100  
Email: Anne.Cappella@weil.Com

Christopher T Marando  
ATTORNEY TO BE NOTICED  
Weil, Gotshal & Manges LLP-Washington  
1300 Eye St, Nw Suite 900  
Washington , DC 20005-3314  
USA  
202/682-7500  
Fax: 202/857-0940  
Email: Christopher.Marando@weil.Com

David M DesRosier  
ATTORNEY TO BE NOTICED  
Weil, Gotshal & Manges LLP-Washington  
1300 Eye St, Nw Suite 900  
Washington , DC 20005-3314  
USA  
202.682.7500  
Fax: 202.857.0940  
Email: David.Desrosier@weil.Com

Eric Hugh Findlay  
ATTORNEY TO BE NOTICED  
Findlay Craft PC  
102 N College Avenue Suite 900  
Tyler , TX 75702  
USA  
903/534-1100  
Fax: 903/534-1137  
Email: Efindlay@findlaycraft.Com

Jill Jane Schmidt  
ATTORNEY TO BE NOTICED  
Weil Gotshal & Manges, LLP - Redwood Shores  
201 Redwood Shores Parkway 5th Floor  
Redwood City , CA 94065  
USA  
650-802-3000  
Fax: 650-802-3100  
Email: Jill.Schmidt@weil.Com

Roger Brian Craft  
ATTORNEY TO BE NOTICED  
Findlay Craft PC  
102 N College Avenue Suite 900  
Tyler , TX 75702  
USA  
903/534-1100  
Fax: 903/534-1137  
Email: Bcraft@findlaycraft.Com

Craig Steven Jepson  
ATTORNEY TO BE NOTICED  
Reed & Scardino LLP  
301 Congress Ave  
Ste 1250  
Austin , TX 78701  
USA  
512-615-5787  
Fax: 512-474-2622  
Email: Cjepson@reedscardino.Com

Deron R Dacus  
ATTORNEY TO BE NOTICED

Mobile Telecommunications Technologies Llc  
Counter Defendant

[The Dacus Firm, PC](#)  
821 Ese Loop 323 Suite 430  
Tyler, TX 75701  
USA  
903/705-1117  
Fax: 9037051117  
Email: Ddacus@dacusfirm.Com

[Henning Schmidt](#)  
ATTORNEY TO BE NOTICED  
[Reed & Scardino LLP](#)  
301 Congress Ave  
Ste 1250  
Austin, TX 78701  
USA  
512-615-5473  
Fax: 512-474-2622  
Email: Hschmidt@reedscardino.Com

[John Lawrence Hendricks](#)  
ATTORNEY TO BE NOTICED  
[Farney Daniels, PC - Dallas](#)  
8401 N. Central Expressway Suite 280  
Dallas, TX 75225  
USA  
972-432-5780  
Fax: 972-432-5781  
Email: Jhendricks@reedscardino.Com

[Joshua Gabriel Jones](#)  
ATTORNEY TO BE NOTICED  
[Reed & Scardino LLP](#)  
301 Congress Ave  
Ste 1250  
Austin, TX 78701  
USA  
512-615-5474  
Email: Jjones@reedscardino.Com

[Mark W Halderman](#)  
ATTORNEY TO BE NOTICED  
[Reed & Scardino LLP](#)  
301 Congress Ave  
Ste 1250  
Austin, TX 78701  
USA  
512-474-2449  
Fax: 512-474-2622  
Email: Mhalderman@reedscardino.Com

[Steven Tepera](#)  
ATTORNEY TO BE NOTICED  
[Reed & Scardino LLP](#)  
301 Congress Ave  
Ste 1250  
Austin, TX 78701  
USA  
512-474-2449  
Fax: 512-474-2622  
Email: Stepera@reedscardino.Com

[Daniel Scardino](#)  
ATTORNEY TO BE NOTICED  
[Reed & Scardino LLP](#)  
301 Congress Ave  
Ste 1250  
Austin, TX 78701  
USA  
512-474-2449  
Fax: 512-474-2622  
Email: Dscardino@reedscardino.Com

Date	#	Proceeding Text	Source
04/02/2013	1	COMPLAINT against Apple, Inc. ( Filing fee \$ 350 receipt number 0540-4074656.), filed by Mobile Telecommunications Technologies, LLC. (Attachments: # 1 Civil Cover Sheet) (Scardino, Daniel) (Entered: 04/02/2013)	
04/03/2013		Judge Rodney Gilstrap and Magistrate Judge Roy S. Payne added (ehs, ) Modified on 4/3/2013 (ehs, ). (Entered: 04/03/2013)	
04/03/2013	2	ORDER REFERRING CASE for Pretrial proceedings to Magistrate Judge Roy S. Payne. Signed by Judge Rodney Gilstrap on 3/3/13. (ehs, ) (Entered: 04/03/2013)	
04/03/2013		In accordance with the provisions of 28 USC Section 636(c), you are hereby notified that a U.S. Magistrate Judge of this district court is available to conduct any or all proceedings in this case including a jury or non-jury trial and to order the entry of a final judgment. The form Consent to Proceed Before Magistrate Judge is available on our website. All signed consent forms, excluding pro se parties, should be filed electronically using the event Notice of Consent to Proceed Before Magistrate Judge. (ehs, ) (Entered: 04/03/2013)	
04/03/2013	3	Additional Attachments to Main Document: 1 Complaint.. (Attachments: # 1 Exhibit A, # 2 Exhibit B, # 3 Exhibit C, # 4 Exhibit D, # 5 Exhibit E, # 6 Exhibit F, # 7 Exhibit G)(Scardino, Daniel) (Entered: 04/03/2013)	
04/03/2013	4	Notice of Filing of Patent/Trademark Form (AO 120). AO 120 mailed to the Director of the U.S. Patent and Trademark Office. (Attachments: # 1 Exhibit 1)(Scardino, Daniel) (Entered: 04/03/2013)	
04/04/2013	5	NOTICE of Attorney Appearance by John Lawrence Hendricks on behalf of Mobile Telecommunications Technologies LLC (Hendricks, John) (Entered: 04/04/2013)	
04/04/2013	6	NOTICE of Attorney Appearance by Steven Tepera on behalf of Mobile Telecommunications Technologies LLC (Tepera, Steven) (Entered: 04/04/2013)	
04/04/2013	7	CORPORATE DISCLOSURE STATEMENT filed by Mobile Telecommunications Technologies LLC identifying Corporate Parent United Wireless Holdings Inc. for Mobile Telecommunications Technologies LLC. (Scardino, Daniel) (Entered: 04/04/2013)	
05/01/2013	8	NOTICE of Attorney Appearance by Deron R Dacus on behalf of Mobile Telecommunications Technologies LLC (Dacus, Deron) (Entered: 05/01/2013)	
05/28/2013	9	NOTICE of Attorney Appearance by Eric Hugh Findlay on behalf of Apple Inc (Findlay, Eric) (Entered: 05/28/2013)	
05/28/2013	10	NOTICE of Attorney Appearance by Roger Brian Craft on behalf of Apple Inc (Craft, Roger) (Entered: 05/28/2013)	
06/27/2013	11	WAIVER OF SERVICE Returned Executed by Mobile Telecommunications Technologies LLC. Apple Inc waiver sent on 6/5/2013, answer due 8/5/2013. (ehs, ) (Entered: 06/27/2013)	
07/17/2013	12	NOTICE of Attorney Appearance by Henning Schmidt on behalf of Mobile Telecommunications Technologies LLC (Schmidt, Henning) (Entered: 07/17/2013)	
07/17/2013	13	NOTICE of Attorney Appearance by Craig Steven Jepson on behalf of Mobile Telecommunications Technologies LLC (Jepson, Craig) (Entered: 07/17/2013)	
07/18/2013	14	NOTICE of Attorney Appearance by Jill Jane Schmidt on behalf of Apple Inc (Schmidt, Jill) (Entered: 07/18/2013)	
07/18/2013	15	NOTICE of Attorney Appearance by Garland T Stephens on behalf of Apple Inc (Stephens, Garland) (Entered: 07/18/2013)	
07/18/2013	16	NOTICE of Attorney Appearance by Anne Marie Cappella on behalf of Apple Inc (Cappella, Anne) (Entered: 07/18/2013)	
07/18/2013	17	NOTICE of Attorney Appearance - Pro Hac Vice by Anish R Desai on behalf of Apple Inc. Filing fee \$ 100, receipt number 0540-4228164. (Desai, Anish) (Entered: 07/18/2013)	
07/18/2013	18	NOTICE of Attorney Appearance by Brian E Ferguson on behalf of Apple Inc (Ferguson, Brian) (Entered: 07/18/2013)	
07/19/2013	19	NOTICE of Attorney Appearance by Mark W Halderman on behalf of Mobile Telecommunications Technologies LLC (Halderman, Mark) (Entered: 07/19/2013)	
07/24/2013	20	NOTICE of Attorney Appearance - Pro Hac Vice by David M DesRosier on behalf of Apple Inc. Filing fee \$ 100, receipt number 0540-4235034. (DesRosier, David) (Entered: 07/24/2013)	
07/31/2013	21	NOTICE of Attorney Appearance - Pro Hac Vice by Christopher T Marando on behalf of Apple Inc. Filing fee \$ 100, receipt number 0540-4244973. (Marando, Christopher) (Entered: 07/31/2013)	
08/05/2013	22	MOTION to Dismiss Plaintiff's Claims for Willful Infringement by Apple Inc. (Attachments: # 1 Text of Proposed Order)(Findlay, Eric) (Entered: 08/05/2013)	
08/05/2013	23	ANSWER to 1 Complaint, COUNTERCLAIM against Mobile Telecommunications Technologies LLC by Apple Inc.(Findlay, Eric) (Entered: 08/05/2013)	



08/05/2013	24	DEMAND for Trial by Jury by Apple Inc. (Findlay, Eric) (Entered: 08/05/2013)
08/05/2013	25	CORPORATE DISCLOSURE STATEMENT filed by Apple Inc identifying Corporate Parent None for Apple Inc. (Findlay, Eric) (Entered: 08/05/2013)
08/09/2013	26	NOTICE by Mobile Telecommunications Technologies LLC of Readiness for Status Conference (Halderman, Mark) (Entered: 08/09/2013)
08/14/2013	27	NOTICE of Attorney Appearance by Joshua Gabriel Jones on behalf of Mobile Telecommunications Technologies LLC (Jones, Joshua) (Entered: 08/14/2013)
08/20/2013	28	***DEFICIENT DOCUMENT, PLEASE IGNORE*** MOTION to Consolidate Cases by Mobile Telecommunications Technologies LLC. (Attachments: # 1 Text of Proposed Order Proposed Order)(Scardino, Daniel) Modified on 8/21/2013 (sm, ). (Entered: 08/20/2013)
08/21/2013		NOTICE of DEFICIENCY regarding the #28 Motion to consolidate submitted by Mobile Telecommunications Technologies LLC. no certificate of conference was included. Correction should be made by 1 business day and refiled. Motion now TERMINATED. (sm, ) (Entered: 08/21/2013)
08/22/2013	29	AMENDED COMPLAINT against All Defendants, filed by Mobile Telecommunications Technologies LLC. (Attachments: # 1 Exhibit A, # 2 Exhibit B, # 3 Exhibit C, # 4 Exhibit D, # 5 Exhibit E, # 6 Exhibit F, # 7 Exhibit G)(Scardino, Daniel) (Entered: 08/22/2013)
08/22/2013	30	RESPONSE to Motion re 22 MOTION to Dismiss Plaintiff's Claims for Willful Infringement filed by Mobile Telecommunications Technologies LLC. (Attachments: # 1 Text of Proposed Order) (Scardino, Daniel) (Entered: 08/22/2013)
08/26/2013	31	Plaintiff Mobile Telecommunications Technologies LLC's ANSWER to 23 Answer to Complaint, Counterclaim of Apple, Inc. by Mobile Telecommunications Technologies LLC.(Scardino, Daniel) (Entered: 08/26/2013)
08/28/2013	32	Unopposed MOTION to Consolidate Cases by Mobile Telecommunications Technologies LLC. (Attachments: # 1 Text of Proposed Order Proposed Order)(Jepson, Craig) (Entered: 08/28/2013)
08/30/2013	33	ORDER granting 32 Motion to Consolidate Cases. Case No. 2:12-cv-832 is hereby designated as the lead case. ****ALL FUTURE FILINGS MUST BE MADE IN THE LEAD CASE UNTIL THE CONSOLIDATON ORDER IS VACATED.*** Signed by Magistrate Judge Roy S. Payne on 8/30/13. (bas, ) (Entered: 08/30/2013)
09/03/2013	34	REPLY to Response to Motion re 22 MOTION to Dismiss Plaintiff's Claims for Willful Infringement filed by Apple Inc. (Findlay, Eric) (Entered: 09/03/2013)
09/09/2013	35	MOTION to Dismiss Plaintiff's Amended Claims for Willful Infringement by Apple Inc. (Attachments: # 1 Text of Proposed Order)(Findlay, Eric) (Entered: 09/09/2013)
09/09/2013	36	ANSWER to 29 Amended Complaint and, COUNTERCLAIM against Mobile Telecommunications Technologies LLC by Apple Inc.(Findlay, Eric) (Entered: 09/09/2013)
10/04/2013	37	RESPONSE to 36 Answer to Amended Complaint, Counterclaim filed by Mobile Telecommunications Technologies LLC. (Jepson, Craig) (Entered: 10/04/2013)
12/17/2013		ORDER finding as moot 22 Motion to Dismiss. Signed by Magistrate Judge Roy S. Payne on 12/17/2013. (rsp2, ) (Entered: 12/17/2013)
03/19/2014	38	NOTICE OF FILING OF OFFICIAL TRANSCRIPT of Claim Construction Hearing held on 3/7/2014 before Judge Roy Payne. Court Reporter: Tonya Jackson, Telephone number: 409.654.2833. NOTICE RE REDACTION OF TRANSCRIPTS: The parties have seven (7) business days to file with the Court a Notice of Intent to Request Redaction of this transcript. If no such Notice is filed, the transcript will be made remotely electronically available to the public without redaction after 90 calendar days. The policy is located on our website at www.txed.uscourts.gov Transcript may be viewed at the court public terminal or purchased through the Court Reporter/Transcriber before the deadline for Release of Transcript Restriction. After that date it may be obtained through PACER.. Redaction Request due 4/14/2014. Redacted Transcript Deadline set for 4/24/2014. Release of Transcript Restriction set for 6/20/2014. (tj, ) (Entered: 03/19/2014)
04/24/2014	39	NOTICE OF FILING OF OFFICIAL TRANSCRIPT of Motion Hearing held on April 16, 2014 before Judge Roy S. Payne. Court Reporter: Christina Bickham, Telephone number: 409-654-2891. &t;P&t;NOTICE RE REDACTION OF TRANSCRIPTS: The parties have seven (7) business days to file with the Court a Notice of Intent to Request Redaction of this transcript. If no such Notice is filed, the transcript will be made remotely electronically available to the public without redaction after 90 calendar days. The policy is located on our website at www.txed.uscourts.gov&t;P&t; Transcript may be viewed at the court public terminal or purchased through the Court Reporter before the deadline for Release of Transcript Restriction. After that date it may be obtained through PACER.. Redaction Request due 5/19/2014. Redacted Transcript Deadline set for 5/30/2014. Release of Transcript Restriction set for 7/28/2014. (clb, ) (Entered: 04/24/2014)
05/01/2014	40	NOTICE of Attorney Appearance - Pro Hac Vice by Brian Chang on behalf of Apple Inc. Filing fee \$ 100, receipt number 0540-4639705. (Chang, Brian) (Entered: 05/01/2014)

[Order documents](#) from our nationwide document retrieval service.  
- OR - Call **1.866.540.8818**.

Copyright © 2014 LexisNexis CourtLink, Inc. All rights reserved.  
\*\*\* THIS DATA IS FOR INFORMATIONAL PURPOSES ONLY \*\*\*

**IN THE UNITED STATES DISTRICT COURT  
FOR THE EASTERN DISTRICT OF TEXAS  
MARSHALL DIVISION**

MOBILE TELECOMMUNICATIONS  
TECHNOLOGIES, LLC

v.

CLEARWIRE CORP., et al.

§  
§  
§  
§  
§  
§

Case No. 2:12-cv-308-JRG-RSP

**CLAIM CONSTRUCTION  
MEMORANDUM AND ORDER**

On June 7, 2013, the Court held a claim construction hearing concerning U.S. Patent No. 5,590,403 (the “‘403 Patent”). Having considered the arguments and evidence presented by the parties at the hearing and in their briefing (Dkt. Nos. 60, 61, and 64), the Court issues this Claim Construction Order.

The ‘403 Patent generally relates to a system for providing two-way communication between a plurality of transmitters and mobile units. ‘403 Patent at Abstract. The patent addresses techniques in which improved communication is provided over a relatively large area. ‘403 Patent at 1:8-14. The patent includes two independent claims. Claim 1 is directed toward concepts in which the transmitters are divided into a first and second set of transmitters. During a first time period a first block of information is transmitted by the first and second sets of transmitters in simulcast. During a second time period the first set of transmitters transmits a second block of information and the second set of transmitters transmits a third block of information. Independent claim 10 relates to a concept in which a region of space is divided into a plurality of zones, each zone having at least one base transmitter. A first set of transmitters assigned to a first zone transmits a first information signal in simulcast and a second set of transmitters assigned to a second zone transmits a second information signal in simulcast.

At least one transmitter assigned to the first set of transmitters may be dynamically reassigned from the first zone to the second zone.

#### APPLICABLE LAW

“It is a ‘bedrock principle’ of patent law that ‘the claims of a patent define the invention to which the patentee is entitled the right to exclude.’” *Phillips v. AWH Corp.*, 415 F.3d 1303, 1312 (Fed. Cir. 2005) (en banc) (quoting *Innova/Pure Water Inc. v. Safari Water Filtration Sys., Inc.*, 381 F.3d 1111, 1115 (Fed. Cir. 2004)). To determine the meaning of the claims, courts start by considering the intrinsic evidence. *See id.* at 1313. *C.R. Bard, Inc. v. U.S. Surgical Corp.*, 388 F.3d 858, 861 (Fed. Cir. 2004); *Bell Atl. Network Servs., Inc. v. Covad Commc’ns Group, Inc.*, 262 F.3d 1258, 1267 (Fed. Cir. 2001). The intrinsic evidence includes the claims themselves, the specification, and the prosecution history. *See Phillips*, 415 F.3d at 1314; *C.R. Bard, Inc.*, 388 F.3d at 861. Courts give claim terms their ordinary and accustomed meaning as understood by one of ordinary skill in the art at the time of the invention in the context of the entire patent. *Phillips*, 415 F.3d at 1312–13; *Alloc, Inc. v. Int’l Trade Comm’n*, 342 F.3d 1361, 1368 (Fed. Cir. 2003).

The claims themselves provide substantial guidance in determining the meaning of particular claim terms. *Phillips*, 415 F.3d at 1314. First, a term’s context in the asserted claim can be very instructive. *Id.* Other asserted or unasserted claims can also aid in determining the claim’s meaning because claim terms are typically used consistently throughout the patent. *Id.* Differences among the claim terms can also assist in understanding a term’s meaning. *Id.* For example, when a dependent claim adds a limitation to an independent claim, it is presumed that the independent claim does not include the limitation. *Id.* at 1314–15.

“[C]laims ‘must be read in view of the specification, of which they are a part.’” *Id.* (quoting *Markman v. Westview Instruments, Inc.*, 52 F.3d 967, 979 (Fed. Cir. 1995) (en banc)).

“[T]he specification ‘is always highly relevant to the claim construction analysis. Usually, it is dispositive; it is the single best guide to the meaning of a disputed term.’” *Id.* (quoting *Vitronics Corp. v. Conception, Inc.*, 90 F.3d 1576, 1582 (Fed. Cir. 1996)); *Teleflex, Inc. v. Ficoso N. Am. Corp.*, 299 F.3d 1313, 1325 (Fed. Cir. 2002). This is true because a patentee may define his own terms, give a claim term a different meaning than the term would otherwise possess, or disclaim or disavow the claim scope. *Phillips*, 415 F.3d at 1316. In these situations, the inventor’s lexicography governs. *Id.* The specification may also resolve ambiguous claim terms “where the ordinary and accustomed meaning of the words used in the claims lack sufficient clarity to permit the scope of the claim to be ascertained from the words alone.” *Teleflex, Inc.*, 299 F.3d at 1325. But, “[a]lthough the specification may aid the court in interpreting the meaning of disputed claim language, particular embodiments and examples appearing in the specification will not generally be read into the claims.” *Comark Commc’ns, Inc. v. Harris Corp.*, 156 F.3d 1182, 1187 (Fed. Cir. 1998) (quoting *Constant v. Advanced Micro-Devices, Inc.*, 848 F.2d 1560, 1571 (Fed. Cir. 1988)); see also *Phillips*, 415 F.3d at 1323. The prosecution history is another tool to supply the proper context for claim construction because a patent applicant may also define a term in prosecuting the patent. *Home Diagnostics, Inc. v. Lifescan, Inc.*, 381 F.3d 1352, 1356 (Fed. Cir. 2004) (“As in the case of the specification, a patent applicant may define a term in prosecuting a patent.”).

Although extrinsic evidence can be useful, it is “less significant than the intrinsic record in determining the legally operative meaning of claim language.” *Phillips*, 415 F.3d at 1317 (quoting *C.R. Bard, Inc.*, 388 F.3d at 862). Technical dictionaries and treatises may help a court understand the underlying technology and the manner in which one skilled in the art might use claim terms, but technical dictionaries and treatises may provide definitions that are too broad or

may not be indicative of how the term is used in the patent. *Id.* at 1318. Similarly, expert testimony may aid a court in understanding the underlying technology and determining the particular meaning of a term in the pertinent field, but an expert’s conclusory, unsupported assertions as to a term’s definition is entirely unhelpful to a court. *Id.* Generally, extrinsic evidence is “less reliable than the patent and its prosecution history in determining how to read claim terms.” *Id.*

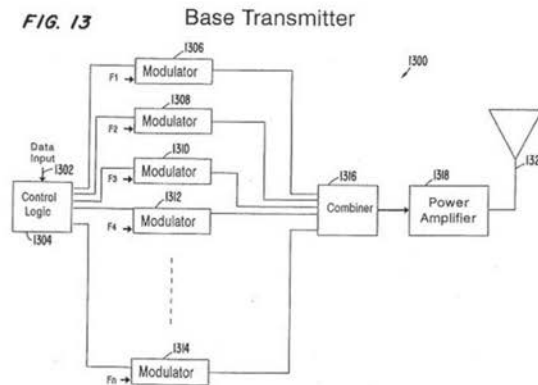
**CONSTRUCTION OF DISPUTED TERMS**

**A. “transmitter” / “base transmitter”**

MTEL Proposed Construction	Clearwire Proposed Construction
No construction necessary	communications device having a data input, a control logic, modulators, a combiner, power amplifier(s), and antenna(e)

The parties first dispute the meaning of the terms “transmitter” and “base transmitter.” The Court finds that the terms “transmitter” and “base transmitter” should be given their plain and ordinary meaning.

Clearwire argues that the terms “transmitter” and “base transmitter” should be limited to the structure disclosed in Figures 13 and 14:



The Court rejects this position. The specification clearly identifies Figure 13, for example, as “show[ing] a first preferred embodiment of a base transmitter 1300.” ‘403 Patent at 15:44-46. Similarly, the specification describes Figure 14 as “show[ing] a second preferred embodiment of a base transmitter 1400.” *Id.* at 16:7-8. “‘Although the specification may aid the court in interpreting the meaning of disputed claim language, particular embodiments and examples appearing in the specification will not generally be read into the claims.’” *Comark Commc’ns*, 156 F.3d at 1187. Although a person of ordinary skill in the art might understand the structure shown in Figures 13 and 14 to be a transmitter, it would be inappropriate to limit the term “transmitter” to **only** that structure, especially in light of the qualifying language of the specification. Thus, the Court declines to import the precise structure shown in Figures 13 and 14 into the claims.

MTEL argues that no construction is necessary for the terms “transmitter” and “base transmitter,” but at the hearing, declined to provide an explanation as to how these terms would be understood by a person of ordinary skill in the art. MTEL did imply, however, that a single unit transmitting multiple signals might be considered multiple transmitters. MTEL further argued that because both independent claims at issue are method claims, the infringement lies in a device’s ability to “transmit” rather than its specific structure. Although the Court recognizes that claims 1 and 10 are method claims, a person of ordinary skill in the art would understand the terms “transmitter” and “base transmitter” to refer to a structural unit, and thus, the number of transmitters in a given system or method is dependent on structure, not function. The specification supports such an interpretation: “[e]ach base transmitter unit . . . receives transmitter control data and message data transmitted from satellite 606.” ‘403 Pat. at 15:42-44.

(Emphasis added.) For this reason, the Court rejects MTEL’s implication that transmitting multiple signals or outputs from a single structural unit can suffice as multiple transmitters.

Finally, as discussed in further detail below, the Court rejects Clearwire’s proposition that a “transmitter” must be spatially separated or geographically dispersed from other transmitters, because Clearwire has provided no evidence to support reading such a limitation into the claims.

**B. “plurality of transmitters” (claims 1, 10) / “plurality of zones” (claim 10)**

<b>MTEL Proposed Construction</b>	<b>Clearwire Proposed Construction</b>
No construction necessary	at least two transmitters
In the alternative: “more than one transmitter”	at least two zones
In the alternative: “more than one zone”	

The primary dispute with regard to “plurality” relates to whether a “plurality” of a particular item requires two of those items or would include one plus some fraction of the item.

As Clearwire notes, the Federal Circuit has found on multiple occasions that “plurality” ordinarily means “at least two.” *Apple Inc. v. Samsung Elec. Co.*, 695 F.3d 1370, 1378 (Fed. Cir. 2012); *Bilstad v. Wakalopoulos*, 386 F.3d 1116, 119 (Fed. Cir. 2004); *ResQNet.com, Inc. v. Lansa, Inc.*, 346 F.3d 1374, 1384 (Fed. Cir. 2003). The text of the ‘403 patent provides no reason to deviate from this general rule. *See, e.g.*, claim 10 (specifying both a “first zone” and “second zone,” and a “first set” and “second set” of transmitters). The Court also notes that, when given the opportunity at the claim construction hearing, MTEL did not object to the Court’s proposed construction of “at least two “transmitters” and “at least two zones.” The Court finds that a “plurality of transmitters” means “at least two transmitters,” and a “plurality of zones” means “at least two zones.”



**C. “zone[s]”**

<b>MTEL Proposed Construction</b>	<b>Clearwire Proposed Construction</b>
No construction necessary	transmitters the network operations center assigns to the same region of space, the boundary of which is roughly defined by the coverage areas of a set of transmitters

The Court finds that a “zone” is a “portion of a region of space,” as the claim context requires such a construction. For example, claim 10 states “a region of space divided into a plurality of zones.” In this way, the claims themselves define a zone as a portion of a region of space. The specification also supports this construction: “[g]enerally, the communication system of the present invention roughly divides various regions of space into portions called zones.” ‘403 Pat. at 9:40-43.

The Court rejects Clearwire’s contention that a zone consists of its assigned transmitters, and notes that such a construction would directly conflict with the claim language. Claim 10 recites “a first set of base transmitters assigned to a first zone” and “a second set of base transmitters assigned to second zone.” Thus, the assignment of transmitters to a zone is defined itself by the claim language, and grouping that assignment into the definition of the term “zone” would be both redundant and confusing to a jury.

**D. “set of transmitters” (claim 1) / “set of base transmitters” (claims 10, 11)**

<b>MTEL Proposed Construction</b>	<b>Clearwire Proposed Construction</b>
No construction necessary	transmitters spatially dispersed throughout a geographic region

The primary dispute relates to whether the transmitters must be spatially dispersed. A dispute also is presented as to whether the term requires multiple transmitters. The Court finds

that “set of transmitters” means “a set of at least two transmitters” and “set of base transmitters” means “a set of at least two base transmitters.”

The Court rejects Clearwire’s contention that a “set” of transmitters must be geographically dispersed. The claims merely recite a set of transmitters. Clearwire attempts to read into the claims the particular embodiments of the specification but does not point to language of disavowal in the specification or the prosecution history. In fact, the claims themselves include their own geographical limitations (with regard to regions of space divided into zones), further counseling against reading the features of the preferred embodiments into the definition of the terms “set of transmitters” and “set of base transmitters.”

Similarly, the Court rejects MTEL’s contention that a “set of transmitters” can be a single transmitter. The plain plural language of the claim (“transmitters”) requires at least two transmitters. Further, as conceded by MTEL at the hearing, the remaining limitations of claim 10 clearly shows that if a “set” contained just one transmitter, the method and system claimed would be incapable of functioning in the manner recited.

**E. “transmitting in simulcast” (claim 1) / “transmitted in simulcast” (claim 10)**

<b>MTEL Proposed Construction</b>	<b>Clearwire Proposed Construction</b>
transmitting information over two or more channels or modes	broadcasting identical signals simultaneously

The Court finds that a person of ordinary skill in the art would understand “transmitting in simulcast” to mean “transmitting the same information at the same time.” At the hearing, each party largely agreed with this language, but each proposed minor modifications.

Clearwire proposes that the construction should require that the same **signal** be transmitted, rather than the same **information**. Clearwire provides no rationale for requiring that

the signals be identical, and in fact cites to the specification's recitation that "simulcast technology provides multiple transmitters . . . transmitting the **same information**." '403 Pat. at 1:50-53; *see also* (Dkt. No. 61 at 21). Further, as MTEL correctly notes, the patent explicitly states that "good simulcast practice" has differing signals:

It should also be understood that in accordance with good simulcast practice, the respective carrier frequencies between adjacent based transmitters, such as base transmitter 612 and base transmitter 614 in Figure 6, should be slightly offset.... This frequency offset is preferably on the order of 10-20 hertz.

*See* '403 Pat. at 13:39-46. Thus, the "identical signal" requirement is not only absent from the claims, but the specification specifically envisions a simulcasting embodiment that broadcasts the same information without the use of identical signals. Thus, including such language in the Court's construction would be directly contrary to the specification.

MTEL proposes that the construction be adopted with the addition of ". . . over two or more channels or modes." In support of this proposal, MTEL cites to the specification's discussion of multi-carrier modulation. *See* (Dkt. No. 60 at 15); '403 Pat. at 13:3-15:40. The Court first notes that MTEL provides no support for its assertion that the limitation of ". . . over two or more channels or modes" should be read into the claims, and thus, the Court declines to import that limitation from the specification.

MTEL also implicitly argues that, by using multi-carrier modulation, a single transmitter may operate in simulcast with itself. The Court notes that there is no support in the specification or prosecution history for the suggestion that this meets the definition of "simulcast" as defined by the '403 Patent. In fact, the specification only envisions "multi-carrier simulcast" with two transmitters, which directly contradicts MTEL's implication:

In another embodiment, the invention is directed to a multi-carrier simulcast transmission system for transmitting in a desired frequency band a message contained in an information signal, the system comprising a

first transmitter means for transmitting an information signal by generating a first plurality of carrier signals within the desired frequency band and by modulating the first plurality of carrier signals to convey the information signal, and a second transmitter means, spatially separated from the first transmitter, for transmitting the information signal in simulcast with the first transmitter by generating a second plurality of carrier signals at substantially the same frequencies as the first plurality of carrier signals and by modulating the second plurality of carrier signals to convey the information signal.

'403 Pat. at 5:30-43. Thus, the Court rejects MTEL's proposal to add ". . . over two or more channels or modes" to the Court's construction, and in doing so, rejects MTEL's implicit argument that a single transmitter can operate in simulcast with itself by using multi-carrier modulation.

**F. "dynamically reassigning" claims 10, 11**

<b>MTEL Proposed Construction</b>	<b>Clearwire Proposed Construction</b>
No construction necessary	redefining zonal boundaries by the network operations center reassigning transmitter(s) to a different region of space

The Court finds that "dynamically reassigning" should be given its plain and ordinary meaning.

Neither party objected to this construction at the hearing, but in its brief, Clearwire asserts that the specification describes the dynamic changing of zone assignments by "reassign[ing] base transmitters to new zones based upon the volume of messages." 23:45-41. Clearwire also cites to the passage "in this instance, the zonal boundaries are changed to remove this high traffic region from a zonal overlap area." 24:21-22. Clearwire asserts that the altering of the zone boundaries improves performance. (Dkt. No. 61 at 19.) As to "regions of space," Clearwire asserts that the specification contains multiple descriptions as to how the zone boundaries are changed. (Dkt. No. 61 at 19-20 (citing '403 Pat. at 24:21-22, 34:35-35:3)).

Clearwire's assertion that the specification states that zonal boundaries are redefined may be true, but the claims clearly do not recite such a limitation – in other words, the claim does not include language specifying what the result of that reassignment must be. To include the additional language sought by Clearwire would be an improper re-writing of the claim language that is on its face clear and understandable. That the specification describes an embodiment in which reassignment of the transmitters causes the zone boundaries to change does not dictate that such limitations should be added to the claim.

#### CONCLUSION

The Court adopts the above constructions. The parties are ordered that they may not refer, directly or indirectly, to each other's claim construction positions in the presence of the jury. Likewise, the parties are ordered to refrain from mentioning any portion of this opinion, other than the actual definitions adopted by the Court, in the presence of the jury. Any reference to claim construction proceedings is limited to informing the jury of the definitions adopted by the Court.





US005784001A

**United States Patent** [19]

[11] **Patent Number:** 5,784,001

Deluca et al.

[45] **Date of Patent:** Jul. 21, 1998

[54] **METHOD AND APPARATUS FOR PRESENTING GRAPHIC MESSAGES IN A DATA COMMUNICATION RECEIVER**

[75] **Inventors:** Joan Deluca, Boca Raton; Douglas Kraul, Parkland; Charles Edward Batey, Jr., Lake Worth, all of Fla.

[73] **Assignee:** Motorola, Inc., Schaumburg, Ill.

[21] **Appl. No.:** 898,640

[22] **Filed:** Jul. 21, 1997

**Related U.S. Application Data**

[63] **Continuation of Ser. No. 560,604, Nov. 20, 1995, abandoned.**

[51] **Int. Cl.<sup>6</sup>** ..... G08B 5/22

[52] **U.S. Cl.** ..... 340/825.44; 345/133

[58] **Field of Search** ..... 340/825.44; 345/133, 345/122

[56] **References Cited**

**U.S. PATENT DOCUMENTS**

4,330,780	5/1982	Masaki	340/825.44
4,336,524	6/1982	Levine	340/825.44
4,429,306	1/1984	Macauley et al.	345/195
4,704,608	11/1987	Sato et al.	340/825.44
4,713,808	12/1987	Gaskill et al.	340/825.44
4,860,005	8/1989	De Luca et al.	340/825.44
4,870,402	9/1989	Deluca et al.	340/825.44
4,951,039	8/1990	Schwendeman	340/825.44

5,157,391	10/1992	Weitzen	340/825.44
5,182,553	1/1993	Kung	340/825.44
5,212,721	5/1993	Deluca et al.	379/57
5,223,831	6/1993	Kung et al.	340/825.44
5,257,307	10/1993	Ise	340/825.44
5,347,269	9/1994	Vanden Heuvel et al.	340/825.44
5,452,356	9/1995	Albert	340/825.44
5,512,916	4/1996	Merchant et al.	340/825.44
5,561,702	10/1996	Lipp et al.	340/825.44
5,574,439	11/1996	Miyashita	340/825.44

**FOREIGN PATENT DOCUMENTS**

0 393 794 A1	4/1990	European Pat. Off.	G08B 5/22
55-34710 (A)	3/1980	Japan	
2 197 103	5/1988	United Kingdom	H04B 5/04
2 206 718	1/1989	United Kingdom	H04B 5/04
9103885	3/1991	WIPO	455/154

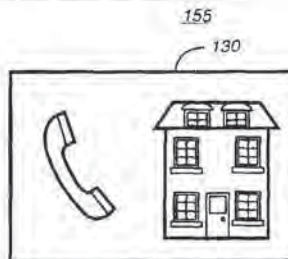
*Primary Examiner*—Brian Zimmerman  
*Assistant Examiner*—Edward Merz

[57] **ABSTRACT**

A data communication receiver (100) includes a receiver (110) for receiving a message including at least one code, a database (155) for storing codes and image data associated with the codes, and a presentation element (150) for locating the at least one code in the database (155). The presentation element (150) then retrieves the image data associated with the at least one code. The image data associated with the at least one code is representative of at least one image. The data communication receiver (100) also includes a display (130) coupled to the presentation element (150) for presenting the at least one image as a graphic message.

**6 Claims, 8 Drawing Sheets**

CODE	IMAGE
#01	TELEPHONE
#02	HOUSE
#03	OFFICE
#04	FAMILY
#05	TRAIN
#06	PERSON RUNNING
#07	COFFEE MUG
#08	CLOCK FOLLOWED BY TIME
#09	FOOD PLATTER



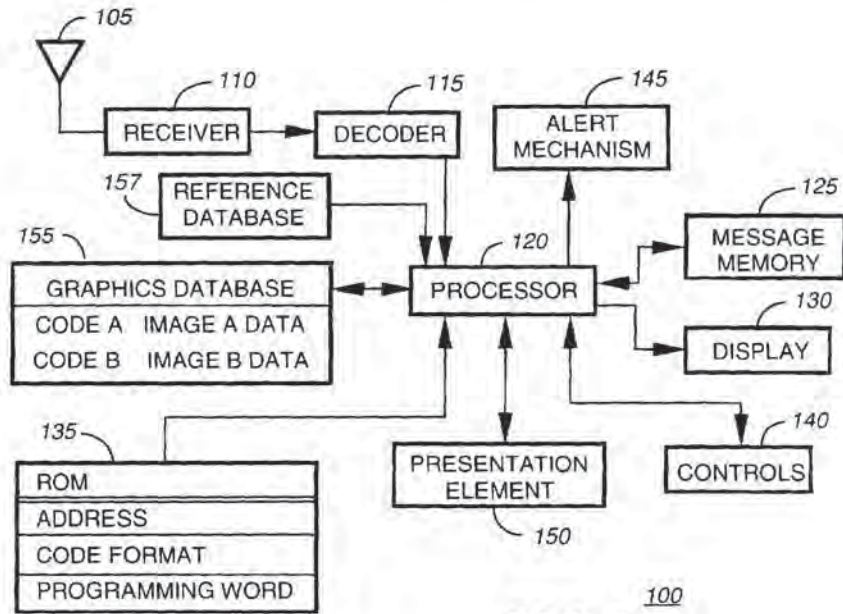
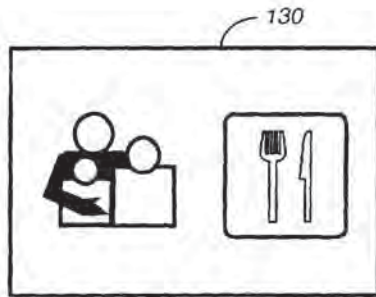


FIG. 1

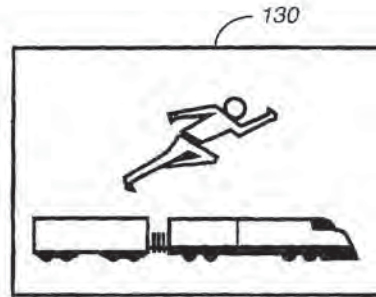
CODE	IMAGE
#01	TELEPHONE
#02	HOUSE
#03	OFFICE
#04	FAMILY
#05	TRAIN
#06	PERSON RUNNING
#07	COFFEE MUG
#08	CLOCK FOLLOWED BY TIME
#09	FOOD PLATTER

FIG. 2

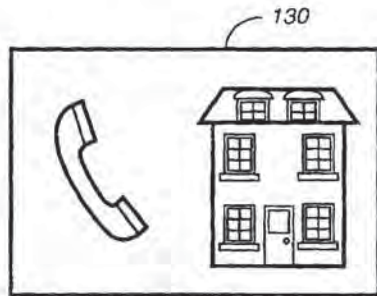




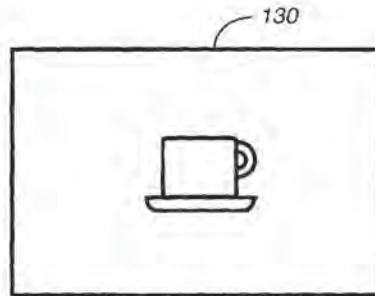
**FIG. 3**



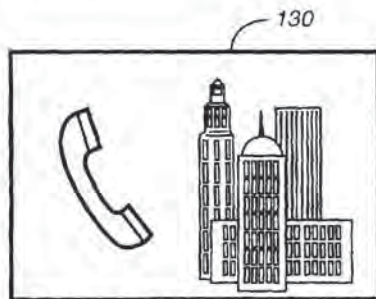
**FIG. 6**



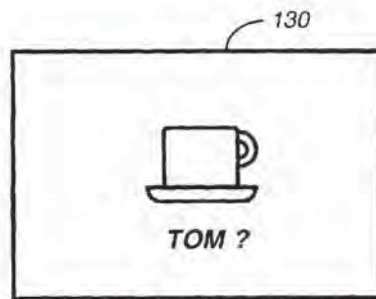
**FIG. 4**



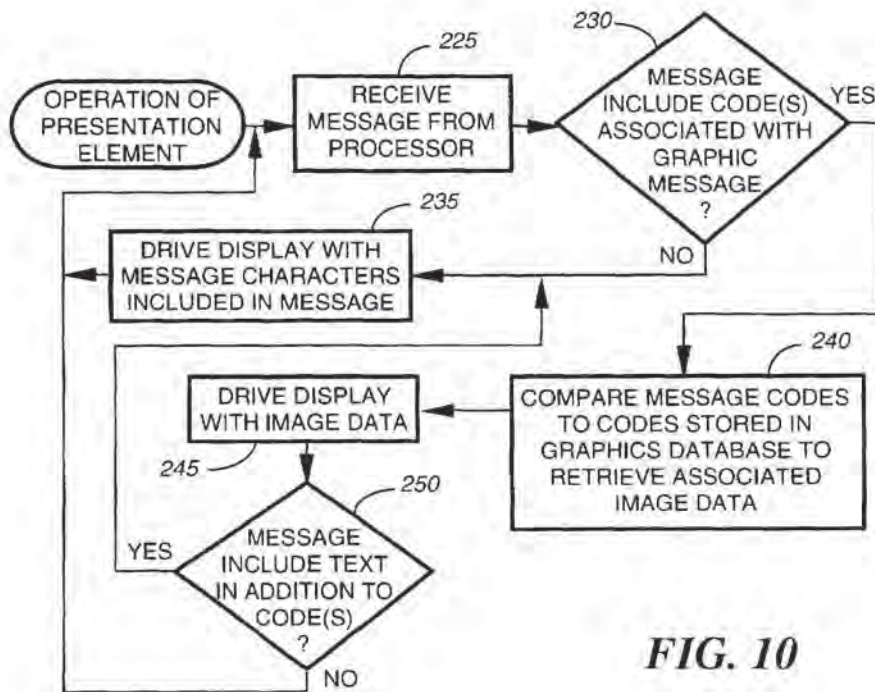
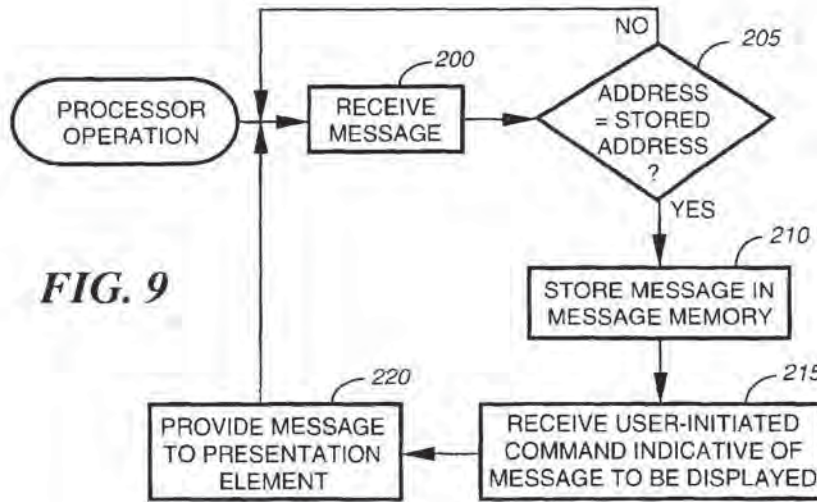
**FIG. 7**

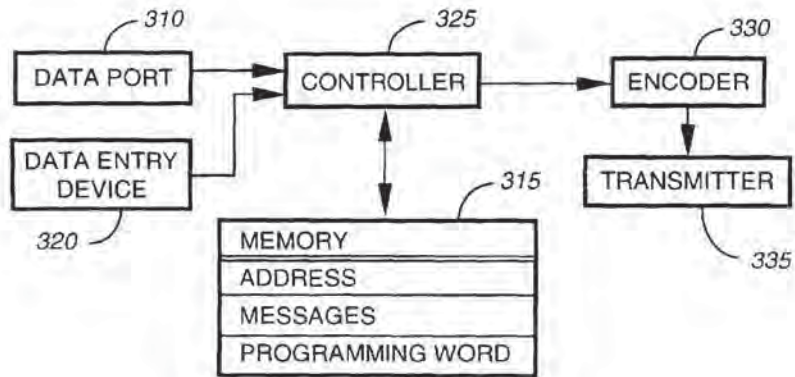


**FIG. 5**

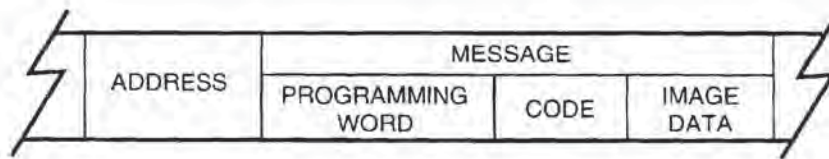


**FIG. 8**





305  
**FIG. 11**



**FIG. 12**

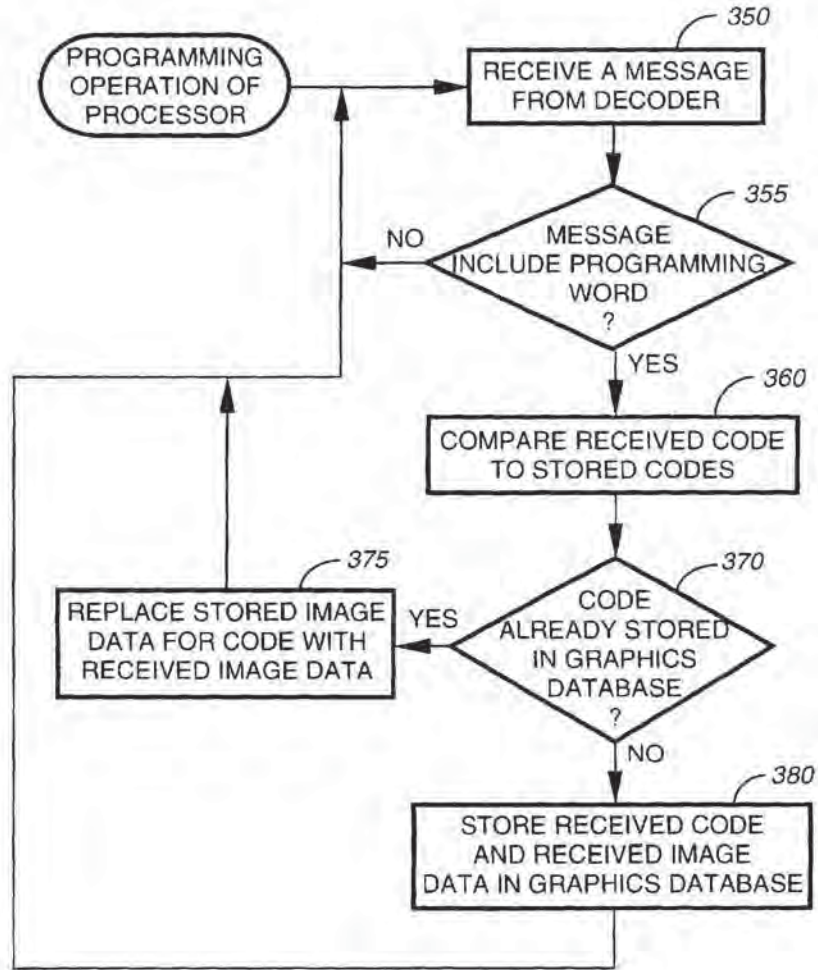


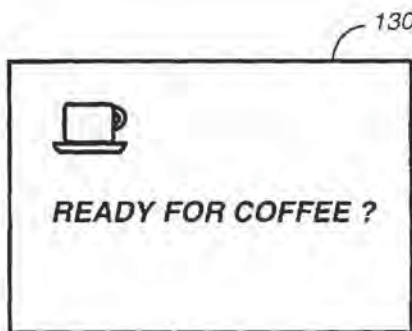
FIG. 13

KEY WORD	IMAGE
CALL, PHONE	TELEPHONE
COFFEE, DRINK	COFFEE MUG
LUNCH, DINNER	PLATTER
SEND, MAIL	ENVELOPE

<sup>500</sup>  
**FIG. 14**



**FIG. 15**



**FIG. 16**

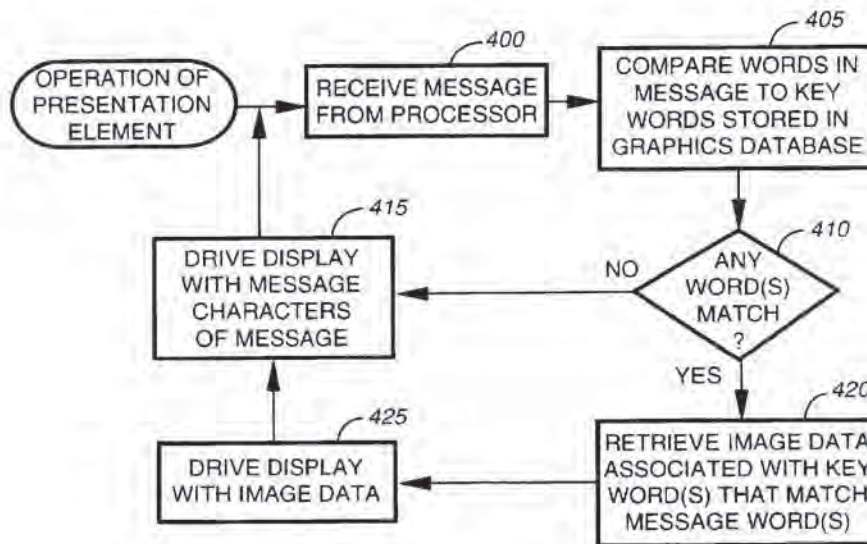


FIG. 17

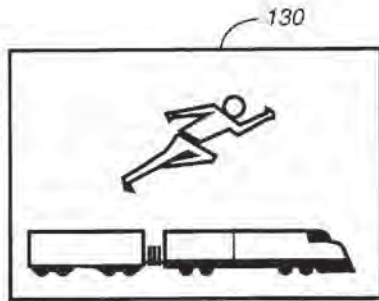


FIG. 18

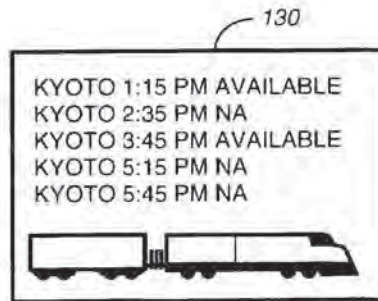


FIG. 19

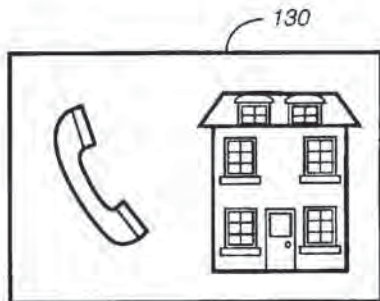


FIG. 20



FIG. 21

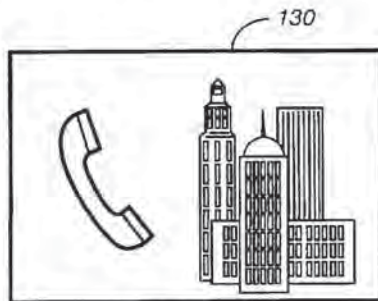


FIG. 22



FIG. 23

**1**

**METHOD AND APPARATUS FOR  
PRESENTING GRAPHIC MESSAGES IN A  
DATA COMMUNICATION RECEIVER**

This is a continuation of application Ser. No. 08/560,604, filed Nov. 20, 1995 now abandoned.

**FIELD OF THE INVENTION**

This invention relates in general to data communication receivers having displays, and more specifically to data communication receivers that can display images.

**BACKGROUND OF THE INVENTION**

Selective call messages are generally originated by a person who wishes to contact the user of a data communication receiver. A message is usually provided to a paging terminal, then transmitted as a radio signal to the receiver. Once the data communication receiver has decoded and stored a message, message reception is announced to the user by, for example, an alert such as an audible tone or predetermined icon. For instance, some prior art devices include a standby display that presents a single, triangular icon for each stored message such that the user can determine the number of messages stored in the receiver. Data communication receivers employ predetermined icons to provide other information, e.g., low battery or out-of-range status, as well.

However, text, rather than icons, is conventionally utilized to present the actual content of received messages to a user of a data communication receiver. Data communication receivers that receive alphanumeric messages and the systems in which they are registered therefore usually are language-specific. As a result, a user who speaks a particular language is unable to understand received messages if he roams into a system in which messages are transmitted in a different language.

Thus, what is needed is a method and apparatus for providing selective call messages that are not language-specific.

**BRIEF DESCRIPTION OF THE DRAWINGS**

FIG. 1 is an electrical block diagram of a data communication receiver for presenting information in accordance with the present invention.

FIG. 2 is an example of codes and image data stored in a graphics database included in the data communication receiver of FIG. 1 in accordance with the present invention.

FIGS. 3-8 are illustrations depicting the presentation of graphic messages on a display of the data communication receiver of FIG. 1 in accordance with the present invention.

FIG. 9 is a flowchart depicting an operation of a processor included in the data communication receiver of FIG. 1 in accordance with the present invention.

FIG. 10 is a flowchart depicting an operation of a presentation element included in the data communication receiver of FIG. 1 in accordance with the present invention.

FIG. 11 is an electrical block diagram of a terminal for providing information to the data communication receiver of FIG. 1 in accordance with the present invention.

FIG. 12 is a signal diagram depicting an example of a programming message transmitted by the terminal of FIG. 11 to the data communication receiver of FIG. 1 in accordance with the present invention.

FIG. 13 is a flowchart depicting a programming operation of the processor of the data communication receiver of FIG. 1 in accordance with the present invention.

**2**

FIG. 14 is an example of key words and image data stored in the graphics database in accordance with the present invention.

FIGS. 15 and 16 are illustrations of supplemental graphic messages provided with text on the display of the data communication receiver of FIG. 1 in accordance with the present invention.

FIG. 17 is a flowchart depicting another operation of the presentation element included in the data communication receiver of FIG. 1 in accordance with the present invention.

FIGS. 18-23 are illustrations further depicting the presentation of graphic messages on a display of the data communication receiver of FIG. 1 in accordance with the present invention.

**DESCRIPTION OF A PREFERRED  
EMBODIMENT**

FIG. 1 is an electrical block diagram of a data communication receiver 100, such as a pager, that includes an antenna 105 for receiving a radio signal and a receiver 110 for demodulating the radio signal. A decoder 115 coupled to the receiver 110 recovers information, such as selective call messages and addresses, included in the demodulated signal. The data communication receiver 100 further includes a processor 120 for processing the recovered information and for determining whether an address in the signal is equivalent to a pager address preferably stored in a memory, such as a read only memory (ROM) 135. A matching address indicates that the message is intended for reception by the data communication receiver 100. The ROM 135 preferably also stores a code format and a programming word, as will be discussed in greater detail below. A message memory 125 is further included in the data communication receiver 100 for storing the received messages intended for reception by the data communication receiver 100. Controls 140 are coupled to the processor 120 for inputting user-initiated commands, such as a display command, and a display 130, such as a liquid crystal display, is coupled to the processor 120 for presenting information to the user. An alert mechanism 145 announces reception of a message to the user by generating an audible, vibratory, or visual alert.

According to the present invention, a presentation element 150 processes each received message to determine whether the message is to be presented graphically, i.e., whether the message comprises a "graphics message," the meaning of which is conveyed pictorially. Preferably, the data communication receiver 100 is able to receive both conventional alphanumeric messages and graphics messages, which are indicated by predetermined codes included in received messages.

By way of example, predetermined characters commonly found on conventional telephone receivers can be used to designate selected codes representative of predetermined graphic images. A message originator can therefore press the buttons associated with the codes to provide graphics information to a selective call terminal, which transmits the codes as a radio signal. When at least one predetermined code is recognized by the data communication receiver 100, a graphics message comprising one or more graphic images is presented to the user of the receiver 100. According to the present invention, the graphic message conveys, in pictures, a universally understood meaning to the user of the data communication receiver 100. The presentation element 150 is preferably implemented in firmware stored in the ROM 135. However, hardware capable of performing equivalent operations can alternatively be used to implement the presentation element 150.



The graphic images available for presenting graphic messages are preferably stored by the data communication receiver 100 in, for example, a graphics database 155. According to the present invention, the graphics database 155 stores a predetermined list of codes, i.e., one or more predetermined characters or a pattern of bits. Each code is associated with image data stored in the database 155. The codes and image data associated therewith can be programmed into the receiver 110 by means such as the controls 140, downloading through a data port (not shown), or over-the-air programming through use of the stored programming word. Therefore, additional codes and image data can be conveniently added to the graphics database 155 as the need for new graphic images arises. Other information to be displayed can be stored in a reference database 157 with cross-references to numeric information, as will be explained in greater detail below.

FIG. 2 is an example of entries in the graphics database 155. As shown, codes recognized by the receiver 100 as indicative of graphic messages begin with the "#" character, which is followed by two numeric characters. In this format, up to one-hundred codes, each associated with image data, could be programmed into the database 155. It will be appreciated, though, that any combination of any number of characters could be utilized to designate graphic messages, as long as the message originator is aware of the codes and the data communication receiver 100 can recognize the codes.

As shown, each code is associated with image data representative of a particular image. For example, code "#01" is associated with image data that represents the image of a telephone. "#02" is associated with a house, while "#03" is associated with an office. According to the present invention, reception of a display command for a received message including any of the stored codes will result in the presentation of the associated image or images on the display 130.

Referring next to FIGS. 3-8, illustrations of different graphic messages on the display 130 are shown. FIG. 3, for instance, illustrates the presentation of the graphic message "DINNER WITH FAMILY" in response to reception of the codes "#09#04." FIGS. 4 and 5 depict graphic messages indicating that the user should "CALL HOME" and "CALL THE OFFICE," respectively. In FIG. 5, reception of a display command for a message comprising the codes "#06#05" results in display of a graphic message that indicates "I AM GOING TO THE TRAIN." The graphic message of FIG. 7, associated with the code "#07," is understood to mean "LET'S GET COFFEE" OR "LET'S GET A DRINK."

FIG. 8 illustrates the combination of both a graphic message and a text message including, for example, alphanumeric characters. Reception of a display command for a message comprising the characters of "#07TOM?" or "TOM?#07" results in the presentation of the image associated with the code "#07" as well as the presentation of any additional alphanumeric or numeric characters included in the message. As a result, graphic messages which need clarification can conveniently be supplemented by additional textual information presented substantially coincident with the graphic messages. For example, the user of a data communication receiver 100 may usually take a coffee break with his friend Bob. So, the display of a coffee mug with nothing more might indicate to the user that Bob is ready for coffee. When Tom wants to get coffee, he may therefore need to include additional information, such as his name, to avoid confusion.

There may be circumstances, however, in which the receiver 100 is capable of receiving only numeric information or the message originator can only send numeric information. In such a case, the originator, e.g., Tom, can send a code as well as his telephone number. The message could then comprise "#073331111" or "3331111#07." The codes, as mentioned, are preferably in one or more predetermined formats recognized by the receiver 100, so the receiver 100 will still recognize "#07" as the code indicative of the coffee mug. Additionally, the receiver 100 can then look up the remainder of the message in the reference database 157 to determine which other display information should be displayed along with the coffee mug icon. When "3331111" is located in the reference database 157, the display information corresponding thereto is displayed with the coffee mug. For example, display information associated with the telephone number "3331111" could result in presentation of the name "TOM" with the coffee mug image. When the number is not found in the reference database 157, the number itself is preferably displayed with the coffee mug icon. In this manner, alphanumeric information can be displayed or conveyed (through the displayed telephone number) even though only numeric information is sent and received.

FIG. 9 is a flowchart of an operation of the processor 120. At step 200, the processor 120 receives a message. When, at step 205, the received address is equivalent to the receiver address stored in the ROM 135 (FIG. 1), the message is stored, at step 210, in the message memory 125. When, at step 215, a user-initiated display command is received for the message, the message is provided to the presentation element 150, at step 220.

Referring next to FIG. 10, an operation of the presentation element 150 in accordance with the present invention is depicted. When, at step 225, a message is received from the processor 120, the presentation element 150 determines, at step 230, whether the message includes at least one code associated with a graphic message. As mentioned, the codes associated with graphic messages are preferably in a predetermined format, such as a predetermined character, e.g., "#", followed by specific number of numerals. Therefore, the presentation element 150 can recognize a code associated with a graphic message by determining, with reference to the code format stored in the ROM 135, whether any characters included in the message are arranged in the predetermined code format. When the message does not include a code associated with a graphic message, the message is displayed, at step 235, in a conventional manner. In other words, the display 130 (FIG. 1) is driven with signals to generate the message characters on the display 130.

When, on the other hand, the message does include one or more codes associated with a graphic message, the presentation element 150 compares, at step 240, each code included in the message to the entries in the graphics database 155 (FIG. 1). When a code in the message is determined to be equivalent to a code in the database 155, the image data associated with the matching code is retrieved and used, at step 245, to drive the display 130, thereby presenting the image to the user. When, at step 250, the message includes text in addition to the graphic message code or codes, the additional text is also presented, at step 235.

In accordance with the present invention, the data communication receiver 100 can present the content of received messages to a user by displaying a graphic image or a sequence of graphic images. The graphic images can fully

replace a text message so that a universally understood message is presented pictorially to a user. As a result, a user of the receiver 100 can understand a presented message regardless of his language. The presentation of a telephone image and an office image, for example, is likely to be understood as "CALL THE OFFICE" regardless of the language of the user. In this manner, a sequence of two or more graphic images can be easily combined to convey messages to any user. An advantage of the present invention, therefore, is that a person who roams into a geographic region in which a different language is spoken can still receive messages that are easily understood. Also, persons who speak one language can advantageously receive and understand messages that are originated by speakers of different languages.

FIG. 11 is an electrical block diagram of a terminal 305 included in a communication system for transmitting information to the data communication receiver 100. The terminal 305 preferably includes a data port 310, such as a telephone interface, for receiving messages from message originators and a memory 315 for storing the messages until transmission. The memory 315 also stores addresses associated with data communication receivers, including the data communication receiver 100, that receive messages within the communication system and, when over-the-air programming of data communication receivers is desired, a programming word indicative of programming information. A data entry device 320, such as a keyboard, data port, or modem, provides user inputs so that an operator can update the addresses of the data communication receivers, add subscribers, or program data communication receivers.

A controller 325 coupled to the data port 310, the data entry device 320, and the memory 315 controls the operation of the terminal 305. The terminal 305 further comprises an encoder 330 for encoding messages and addresses using a communication protocol such as the conventional FLEX™ protocol and a transmitter 335 for transmitting the encoded information as a radio signal.

According to the present invention, the codes and the images used by the data communication receiver 100 in forming graphic messages can be programmed to update images or to provide additional images. Programming can be accomplished by direct entry of information by the controls 140 (FIG. 1) of the data communication receiver 100, by over-the-air programming, or by any other means for providing information to the data communication receiver 100.

FIG. 12 is a signal diagram of a radio signal which can be transmitted by the terminal 305 to the data communication receiver 100 for programming new or enhanced images. As shown, the radio signal comprises the address of data communication receiver 100 followed by a programming message, which includes the predetermined programming word stored both by the terminal 305 and the data communication receiver 100. The programming word, which indicates to the data communication receiver 100 that the information appended to the word is to be utilized for programming the graphics database 155, preferably includes a predetermined character or sequence of characters. The message also includes a code, either existing or new, followed by image data to be written into the graphics database 155. Therefore, as graphics technology results in higher resolution graphics that are more easily understood, new image data can be provided to the data communication receiver 100.

FIG. 13 is a flowchart depicting a programming operation of the processor 120 (FIG. 1) according to the present

invention. When, at step 350, a message is received by the processor 120 from the decoder 115, the processor 120 determines, at step 355, whether the message includes the programming word indicative of over-the-air programming. When the programming word is located, the received code is compared, at step 360, with codes stored in the graphics database 155. When, at step 370, the received code already exists in the database 155, the received image data overwrites the image data already stored in the graphics database 155, at step 375. When the received code is not found in the graphics database 155, the processor 120 stores, at step 380, both the received code and the received image data in the database 155. Although over-the-air programming is not the exclusive method for programming the data communication receiver 100, such a method provides for convenient dissemination of programming information without requiring that each user bring his or her data communication receiver into a service center for individual reprogramming.

FIG. 14 is an example of entries in a graphics database 500 in accordance with an alternate embodiment of the present invention. According to the alternate embodiment of the present invention, the data communication receiver 100 recognizes key words in conventional messages then, when the messages are displayed, images associated with the key words are displayed as well to supplement the message. For example, key words such as "CALL" and "PHONE" can be associated with the image of a telephone. Therefore, when a message includes the words "CALL" or "PHONE", the message would be displayed as text along with a supplemental image of a telephone, as shown in the illustration of FIG. 15. FIG. 16 illustrates the display of the text message "READY FOR COFFEE?" along with a supplemental image of a coffee mug. According to the alternate embodiment of the present invention, the presence of the key word "COFFEE" in the received message triggers the display of the coffee mug image.

Referring next to FIG. 17, a flowchart depicts an operation of the presentation element 150 according to the alternate embodiment of the present invention. At step 400, the presentation element 150 receives a message from the processor 120 and then, at step 405, compares the words of the message with the key words stored in the graphics database 500. When, at step 410, no words match, the message is displayed, at step 415, in a conventional manner. When one or more message words are equivalent to key words in the graphics database 500, the image data associated with the key word or words is retrieved, at step 420, from the database 500. Thereafter, at steps 415, 425, the display 130 is driven to display both the message text and the supplemental image.

According to an alternate embodiment of the present invention, the graphics database 155 (FIG. 1) additionally stores database information about the different graphic images that can be displayed. This information augments universally-understood graphic messages and can be accessed via selection of a displayed image by the user. For example, the user could select a displayed image by touch-pad technology, i.e., by touching the image on the display 130, or by operating controls 140 to move a cursor to highlight a displayed image. Examples of information that can be displayed are shown in FIGS. 18-23.

In FIG. 18, the "person running" icon and the "train" icon are displayed to indicate that a particular person is traveling by train or to a train. When the user selects the train icon, such as by touch, database information associated with the train icon is retrieved from the graphics database 155 and provided to the display 130. Referring to FIG. 19, such

information could, for example, comprise information such as a train schedule. When the receiver 100 (FIG. 1) comprises a clock (not shown), the schedule could be displayed only for future times so that space on the display 130 is not wasted by presenting past information that may be only of minimal use to the person reading the display 130. FIG. 20 depicts the display of the graphic message "CALL HOME," which is conveyed by universally-understood images of a telephone and a house. FIG. 21 shows an example of information that can be displayed when the house icon is selected by the user. When the user touches the house, database information such as the address of the house and the telephone number can be retrieved from the graphics database 155 and displayed to remind the user of important information.

FIGS. 22 and 23 show the use of other information in addition to that provided by the graphic message. In FIG. 22, the graphic message "CALL THE OFFICE" or "CALL WORK" is presented solely by graphic images. When the user touches the office, or otherwise selects the office image, information about the office is presented. Such information can include, for example, the address and telephone number associated with the office.

Preferably, stored information, such as that in the graphics database 155, can be programmed into the data communication receiver 100 in a number of ways. For example, information could be entered via the controls 140 or via a data port (not shown) coupled to the processor 120. Alternatively, programming information could be provided to the data communication receiver 100 over the air for reception by the receiver 110. When information is programmed over the air, the user need not suffer the inconvenience of having to take the data communication receiver 100 into a service shop. Instead, information can be frequently updated without ever disturbing the user.

In summary, the data communication receiver as described above receives messages then, in response to predetermined information included in the received messages, displays graphic messages to the user to convey an easily understood, universal message. According to the present invention, this can be done by transmitting predetermined codes to the data communication receiver. Codes in a received message are looked up in a graphics memory to retrieve image data associated with the codes, then an image or a sequence of images is advantageously presented on a display to convey a universally understood message. For example, two images, e.g., a telephone and a house, can be displayed together on the screen to convey the message "CALL HOME." This message will be understood regardless of the language spoken by the user of the data communication receiver. Alternatively, if a text message is desired, the text message can be displayed along with a supplemental image that reinforces the message.

Also, other important information associated with the images forming the graphic messages can be conveniently stored and selectively presented to the user. This additional information could comprise, for example, train schedules associated with a train image, a description of a cafeteria menu associated with a food platter image, an address associated with an office image, etc. The user can easily access this information by selecting the icon, such as by touching the screen or highlighting the icon with a cursor.

It will be appreciated by now that there has been provided a method and apparatus for providing universal messages that can be understood regardless of languages spoken by the user of a data communication receiver.

What is claimed is:

1. A method for displaying messages in a data communication receiver, the method comprising the steps of:

receiving an alphanumeric message;  
receiving a programming message that includes a key word and image data;

storing the key word and the image data in the database;  
referencing a database to determine whether at least one word included in the alphanumeric message matches at least one key word included in the database, wherein the at least one key word is associated with image data that is representative of at least one image;

presenting, when the alphanumeric message includes at least one word that matches at least one key word located in the database, the at least one image as a graphic message that is accompanied by the alphanumeric message on a display; and

presenting, when the alphanumeric message does not include at least one word that matches at least one key word located in the database, the alphanumeric message without an accompanying graphic message on the display.

2. The method of claim 1, wherein the step of receiving the programming message comprises the step of:

receiving the programming message as a radio signal.

3. The method of claim 1, wherein the step of receiving the programming message comprises the step of:

receiving the programming message through use of controls on the data communication receiver.

4. A data communication receiver for presenting information, the data communication receiver comprising:

a receiver for receiving an alphanumeric message including at least one word;

a database for storing key words and image data associated with the key words;

a presentation element coupled to the receiver and the database for determining whether at least one word included in the alphanumeric message matches at least one key word included in the database, wherein the image data associated with the at least one key word is representative of at least one image;

a display coupled to the presentation element for presenting, when the at least one word matches at least one key word, the at least one image as a graphic message accompanied by the alphanumeric message, and for presenting, when the at least one word does not match at least one key word, the alphanumeric message without an accompanying graphic message;

controls coupled to the processor for providing user-initiated commands thereto, wherein presentation of the alphanumeric message and any accompanying graphic message occurs in response to reception of a display command; and

programming means coupled to the processor and to the database for programming the database, the programming means further comprising:

the receiver for receiving a programming message including a key word and image data;

a memory for storing a programming word; and  
storing means for storing the key word and the image data in the database in response to determining that the programming message includes the programming word.

5. A data communication receiver for presenting information, the data communication receiver comprising:

9

- a receiver for receiving an alphanumeric message including at least one word;
- a database for storing key words and image data associated with the key words;
- a presentation element coupled to the receiver and the database for determining whether at least one word included in the alphanumeric message matches at least one key word included in the database, wherein the image data associated with the at least one key word is representative of at least one image;
- a display coupled to the presentation element for presenting, when the at least one word matches at least one key word, the at least one image as a graphic message accompanied by the alphanumeric message, and for presenting, when the at least one word does not match at least one key word, the alphanumeric message without an accompanying graphic message;
- controls coupled to the processor for providing user-initiated commands thereto, wherein presentation of the alphanumeric message and any accompanying graphic message occurs in response to reception of a display command; and
- programming means coupled to the processor and to the database for programming the database, the programming means further comprising:
  - controls for receiving a programming message comprising a key word and image data; and

10

- storing means for storing the key word and the image data in the database.
- 6. A data communication receiver for presenting information, the data communication receiver comprising:
  - a receiver for receiving a message;
  - a decoder coupled to the receiver for decoding the message to recover one or more alphanumeric words therefrom;
  - a memory coupled to the decoder for storing the message;
  - a database coupled to the decoder for storing a plurality of key words and image data associated therewith, the image data representative of images;
  - a presentation element coupled to the database for determining whether at least one alphanumeric word included in the message matches at least one key word included in the database; and
  - a display coupled to the presentation element for presenting, when at least one alphanumeric word matches at least one key word, a corresponding image as a graphic message accompanied by the message, and for presenting, when at least one alphanumeric word does not match at least one key word, the message unaccompanied by any graphic messages.

\* \* \* \* \*

UNITED STATES PATENT AND TRADEMARK OFFICE

---

BEFORE THE PATENT TRIAL AND APPEAL BOARD

---

APPLE INC.,  
Petitioner,

v.

MOBILE TELECOMMUNICATIONS TECHNOLOGIES, LLC,  
Patent Owner.

---

Case IPR2014-01034  
Patent 5,894,506

---

Before MIRIAM L. QUINN, MEREDITH C. PETRAVICK, and  
SCOTT A. DANIELS, *Administrative Patent Judges*.

QUINN, *Administrative Patent Judge*.

JUDGMENT  
Termination of Proceeding  
*37 C.F.R. § 42.72*

On April 22, 2015, the parties filed a joint motion to terminate the instant proceedings pursuant to a settlement agreement. IPR2014-01034, Paper 13. The parties also filed a true copy of their written settlement agreement, made in connection with the termination of the instant proceeding, in accordance with 35 U.S.C. § 317(b) and 37 C.F.R. § 42.74(b). Exhibit 2006. Additionally, the parties submitted a joint request to have their settlement agreement treated as confidential business information under 35 U.S.C. § 317(b) and 37 C.F.R. § 42.74(c). Paper 14.

The instant proceeding is in its early trial stage, before the due date for patent owner's response. The motion is unclear as to whether Petitioner will not participate further in the proceeding regardless of whether the panel grants the motion to terminate. Nevertheless, we are persuaded that termination as to Petitioner is proper as we have not decided the merits of the proceeding.

Patent Owner filed separately, as Exhibit 2007, additional and lengthy arguments as to why it would be appropriate for the panel to terminate the proceeding as to Patent Owner. Those arguments should have been presented in the body of the motion, not as an attachment to the motion, as the arguments form part of the full statement of the reasons for the relief requested in a motion to terminate. *See* 37 C.F.R. §42.22(a)(2). Therefore, the arguments will not be considered.

Upon consideration of the request before us, giving strong preference for settlements early in the proceeding and that no further disputes with Petitioner remain, terminating the instant proceedings with regard to both Petitioner and Patent Owner promotes efficiency and minimizes unnecessary

costs. Based on the posture of this case, it is appropriate to enter judgment.<sup>1</sup>  
*See* 35 U.S.C. § 317(a); 37 C.F.R. § 42.72.

Accordingly, it is:

ORDERED that the joint motion to terminate IPR2014-01034 is  
*granted*;

FURTHER ORDERED that the instant proceeding is hereby  
*terminated* as to the parties: Petitioner and Patent Owner; and

FURTHER ORDERED that the parties' joint request that the  
settlement and agreement be treated as business confidential information  
kept separate from the patent file, and made available only as provided by  
35 U.S.C. § 317(b) and 37 C.F.R. § 42.74(c), is *granted*.

---

<sup>1</sup> A *judgment* means a final written decision by the Board, or a *termination of a proceeding*. 37 C.F.R. § 42.2.

Case IPR2014-01034  
Patent 5,894,506

PETITIONER:

For Apple Inc.:  
W. Karl Renner  
Thomas Rozylowicz  
FISH & RICHARDSON P.C.  
[axf@fr.com](mailto:axf@fr.com)  
[IPR39521-0003IP2@fr.com](mailto:IPR39521-0003IP2@fr.com)

PATENT OWNER:

John R. Kasha  
KASHA LAW LLC  
[john.kasha@kashalaw.com](mailto:john.kasha@kashalaw.com)

Craig Jepson  
REED & SCARDINO LLP  
[cjepson@reedscardino.com](mailto:cjepson@reedscardino.com)



<b>PATENT APPLICATION FEE DETERMINATION RECORD</b> Effective October 1, 1995					Application or Docket Number <b>708696</b>														
<b>CLAIMS AS FILED - PART I</b>																			
(Column 1)					(Column 2)														
FOR	NUMBER FILED				NUMBER EXTRA														
BASIC FEE																			
TOTAL CLAIMS	21 minus 20 = *				1														
INDEPENDENT CLAIMS	4 minus 3 = *				1														
MULTIPLE DEPENDENT CLAIM PRESENT																			
* If the difference in column 1 is less than zero, enter "0" in column 2																			
<b>CLAIMS AS AMENDED - PART II</b>																			
(Column 1)					(Column 2)					(Column 3)									
<b>AMENDMENT A</b>			CLAIMS REMAINING AFTER AMENDMENT				HIGHEST NUMBER PREVIOUSLY PAID FOR		PRESENT EXTRA										
	Total	*	21		Minus	**	21		=										
	Independent	*	5		Minus	***	4		=	1									
	FIRST PRESENTATION OF MULTIPLE DEPENDENT CLAIM																		
(Column 1)					(Column 2)					(Column 3)									
<b>AMENDMENT B</b>			CLAIMS REMAINING AFTER AMENDMENT				HIGHEST NUMBER PREVIOUSLY PAID FOR		PRESENT EXTRA										
	Total	*			Minus	**			=										
	Independent	*			Minus	***			=										
	FIRST PRESENTATION OF MULTIPLE DEPENDENT CLAIM																		
(Column 1)					(Column 2)					(Column 3)									
<b>AMENDMENT C</b>			CLAIMS REMAINING AFTER AMENDMENT				HIGHEST NUMBER PREVIOUSLY PAID FOR		PRESENT EXTRA										
	Total	*			Minus	**			=										
	Independent	*			Minus	***			=										
	FIRST PRESENTATION OF MULTIPLE DEPENDENT CLAIM																		
* If the entry in column 1 is less than the entry in column 2, write "0" in column 3.																			
** If the "Highest Number Previously Paid For" IN THIS SPACE is less than 20, enter "20."																			
*** If the "Highest Number Previously Paid For" IN THIS SPACE is less than 3, enter "3."																			
The "Highest Number Previously Paid For" (Total or Independent) is the highest number found in the appropriate box in column 1.																			

<b>SMALL ENTITY</b>		OR	<b>OTHER THAN SMALL ENTITY</b>	
RATE	FEE		RATE	FEE
	375.00	OR		750.00
x\$11=		OR	x\$22=	22
x39=		OR	x78=	78
+125=		OR	+250=	
TOTAL		OR	TOTAL	850

<b>SMALL ENTITY</b>		OR	<b>OTHER THAN SMALL ENTITY</b>	
RATE	ADDITIONAL FEE		RATE	ADDITIONAL FEE
x\$11=		OR	x\$22=	
x39=		OR	x78=	82
+125=		OR	+250=	82
TOTAL ADDIT. FEE		OR	TOTAL ADDIT. FEE	82

PACE DATA ENTRY CODING SHEET

U.S. DEPARTMENT OF COMMERCE  
Patent and Trademark Office

1ST EXAMINER 414 DATE 10-29-96  
2ND EXAMINER DATE  
SPECIAL HANDLING 0 GROUP ART UNIT 2603 CLASS 370 SHEETS OF DRAWING 7

APPLICATION NUMBER 08/708696  
TYPE APPL 1 FILING DATE MONTH 09 DAY 05 YEAR 96  
TOTAL CLAIMS 21 INDEPENDENT CLAIMS 4 FOREIGN LICENSE Y FILING FEE 850 ATTORNEY DOCKET NUMBER 03680.0132

CONTINUITY DATA

CONT STATUS CODE	PARENT APPLICATION SERIAL NUMBER	PCT APPLICATION SERIAL NUMBER	PARENT PATENT NUMBER	PARENT FILING DATE				
					MONTH	DAY	YEAR	
P	C	T	/	/	/			
P	C	T	/	/	/			
P	C	T	/	/	/			
P	C	T	/	/	/			
P	C	T	/	/	/			

PCT/FOREIGN APPLICATION DATA

FOREIGN PRIORITY CLAIMED


COUNTRY CODE


PCT/FOREIGN APPLICATION SERIAL NUMBER


FOREIGN FILING DATE


**Table of Contents**

---

1. US5894506A Method and apparatus for generating and communicating messages between subscribers to an electronic messaging network
-

**Family 1/1**

**1 record(s) per family**

**Record 1/1** US5894506A Method and apparatus for generating and communicating messages between subscribers to an electronic messaging network

**Publication Number:** US5894506A 19990413

**Title:** Method and apparatus for generating and communicating messages between subscribers to an electronic messaging network

**Title - DWPI:** Message generation and communication method between subscribers of electronic messaging network

**Priority Number:** US1996708696A

**Priority Date:** 1996-09-05

**Application Number:** US1996708696A

**Application Date:** 1996-09-05

**Publication Date:** 1999-04-13

**IPC Class Table:**

IPC	Section	Class	Subclass	Class Group	Subgroup
H04L001258	H	H04	H04L	H04L0012	H04L001258
H04M0003533	H	H04	H04M	H04M0003	H04M0003533
H04M001102	H	H04	H04M	H04M0011	H04M001102
H04M000353	H	H04	H04M	H04M0003	H04M000353

**IPC Class Table - DWPI:**

IPC - DWPI	Section - DWPI	Class - DWPI	Subclass - DWPI	Class Group - DWPI	Subgroup - DWPI
H04M000164	H	H04	H04M	H04M0001	H04M000164

**Assignee/Applicant:** SkyTel Communications Inc., Jackson, MS, US

**JP F Terms:**

**JP FI Codes:**

**Assignee - Original:** SkyTel Communications Inc.

**Any CPC Table:**

Type	Invention	Additional	Version	Office
Current	<b>H04L 12/5835</b>	H04M 3/5322	20130101	EP
Current	H04L 51/066	H04M 2203/4581	20130101	EP
Current	H04M 3/53316		20130101	EP
Current	H04M 11/022		20130101	EP

**ECLA:** H04L001258C2 | H04L005106B | H04M0003533D | H04M001102A | T04M000353T | T04M020345I

**Abstract:**

An electronic messaging network comprises a network operation center and plural message terminals, all including memories for storing corresponding files of canned messages and associated message codes. To send a canned message, a calling party selects a canned message stored at one message terminal and transmits the assigned message code to a receiving party at another message terminal via the network operation center. The receiving terminal retrieves the selected canned message from its memory using the received message code for display to the receiving party. Files of canned responses and associated response codes may also be stored in the memories at the terminals and network operation center to allow the exchange of selected canned response options in conjunction with canned messages to be in response code form.

**Language of Publication:** EN

**INPADOC Legal Status Table:**

Gazette Date	Code	INPADOC Legal Status Impact
2014-09-02	IPR	-
<b>Description:</b> AIA TRIAL PROCEEDING FILED BEFORE THE PATENT AND APPEAL BOARD: INTER PARTES REVIEW TRIAL NO: IPR2014-01034 2014-06-27		
2014-09-02	IPR	-
<b>Description:</b> AIA TRIAL PROCEEDING FILED BEFORE THE PATENT AND APPEAL BOARD: INTER PARTES REVIEW TRIAL NO: IPR2014-01033 2014-06-27		
2013-11-20	AS	-
<b>Description:</b> ASSIGNMENT SKYTEL COMMUNICATIONS, INC., MISSISSIPPI CORRECTIVE ASSIGNMENT TO CORRECT THE SPELLING OF THE NAME OF THE ASSIGNEE PREVIOUSLY RECORDED ON REEL 031122, FRAME 0240. ASSIGNORS HEREBY CONFIRMS THE NAME OF THE ASSIGNEE IS SKYTEL COMMUNICATIONS, INC;		

ASSIGNOR:MOBILE TELECOMMUNICATION TECHNOLOGIES CORP. DBA MOBILE TELECOMMUNICATION TECHNOLOGIES (MTEL); REEL/FRAME:031804/0065 1998-12-14		
2013-08-28	AS	-
<b>Description:</b> ASSIGNMENT NORTH AMERICAN IP HOLDINGS, LLC, TEXAS ASSIGNMENT OF ASSIGNORS INTEREST; ASSIGNOR:ST NETWORK SERVICES LLC; REEL/FRAME:031099/0844 2011-03-31		
2013-08-28	AS	-
<b>Description:</b> ASSIGNMENT MOBILE TELECOMMUNICATIONS TECHNOLOGIES, LLC, TEXAS CHANGE OF NAME; ASSIGNOR:NORTH AMERICAN IP HOLDINGS, LLC; REEL/FRAME:031106/0023 2012-04-01		
2013-08-28	AS	-
<b>Description:</b> ASSIGNMENT SKYTEL COMMUNICATIONS, INC., MISSISSIPPI CORRECTIVE ASSIGNMENT TO CORRECT THE NAME OF THE ASSIGNOR PREVIOUSLY RECORDED ON REEL 009657 FRAME0936. ASSIGNOR(S) HEREBY CONFIRMS THE ASSIGNOR'S NAME IS MOBILE TELECOMMUNICATION TECHNOLOGIES CORP. DBA MOBILE TELECOMMUNICATION TECHNOLOGIES (MTEL); ASSIGNOR:MOBILE TELECOMMUNICATION TECHNOLOGIES CORP. DBA MOBILE TELECOMMUNICATION TECHNOLOGIES (MTEL); REEL/FRAME:031122/0240 1998-12-14		
2013-08-28	AS	-
<b>Description:</b> ASSIGNMENT VELOCITA WIRELESS LLC, NEW JERSEY ASSIGNMENT OF ASSIGNORS INTEREST; ASSIGNOR:BELL INDUSTRIES, INC.; REEL/FRAME:031099/0667 2008-06-11		
2013-08-28	AS	-
<b>Description:</b> ASSIGNMENT BELL INDUSTRIES INC., INDIANA ASSIGNMENT OF ASSIGNORS INTEREST; ASSIGNOR:SKYTEL CORP.; REEL/FRAME:031099/0562 2007-01-31		
2013-08-28	AS	-
<b>Description:</b> ASSIGNMENT ST NETWORK SERVICES LLC, TEXAS ASSIGNMENT OF ASSIGNORS INTEREST; ASSIGNOR:VELOCITA WIRELESS LLC; REEL/FRAME:031099/0751 2009-03-19		
2010-10-13	FPAY	+
<b>Description:</b> FEE PAYMENT		
2007-03-14	AS	-
<b>Description:</b> ASSIGNMENT NEWCASTLE PARTNERS, L.P., TEXAS SECURITY AGREEMENT; ASSIGNORS:BELL INDUSTRIES, INC.; BELL INDUSTRIES, INC.; REEL/FRAME:019009/0529 2007-03-12		
2007-01-31	AS	-
<b>Description:</b> ASSIGNMENT WELLS FARGO FOOTHILL, INC., AS AGENT, CALIFORNIA PATENT SECURITY AGREEMENT; ASSIGNORS:BELL INDUSTRIES, INC., A CALIFORNIA CORPORATION; BELL INDUSTRIES, INC., A		

MINNESOTA CORPORATION; REEL/FRAME:018826/0503 2007-01-31		
2007-01-24	AS	-
<b>Description:</b> ASSIGNMENT SKYTEL CORP., VIRGINIA MERGER; ASSIGNOR:SKYTEL COMMUNICATIONS, INC.; REEL/FRAME:018797/0318 2004-12-31		
2006-10-13	FPAY	+
<b>Description:</b> FEE PAYMENT		
2002-10-30	REMI	-
<b>Description:</b> MAINTENANCE FEE REMINDER MAILED		
2002-10-11	FPAY	+
<b>Description:</b> FEE PAYMENT		
1999-09-14	CC	-
<b>Description:</b> CERTIFICATE OF CORRECTION		
1998-12-22	AS	-
<b>Description:</b> ASSIGNMENT SKYTEL COMMUNICATIONS, INC., MISSISSIPPI ASSIGNMENT OF ASSIGNORS INTEREST; ASSIGNOR:MOBILE TELECOMMUNICATION TECHNOLOGIES (NTEL); REEL/FRAME:009657/0936 1998-12-14		
1996-09-05	AS	-
<b>Description:</b> ASSIGNMENT MOBILE TELECOMMUNICATION TECHNOLOGIES, MISSISSIPPI ASSIGNMENT OF ASSIGNORS INTEREST; ASSIGNOR:PINTER, GREGORY J.; REEL/FRAME:008218/0879 1996-07-16		

**Post-Issuance (US):** CORR-CERT Certificate of Correction 1999-09-14 1999 a Certificate of Correction was issued for this patent

**Reassignment (US) Table:**

Assignee	Assignor	Date Signed	Reel/Frame	Date
MOBILE TELECOMMUNICATIONS TECHNOLOGIES LLC, LEWISVILLE, TX, US	NORTH AMERICAN IP HOLDINGS, LLC	2012-04-01	031106/0023	2013-08-28
<b>Conveyance:</b> CHANGE OF NAME (SEE DOCUMENT FOR DETAILS).				

<b>Corresponent:</b> REED & SCARDINO LLP 301 CONGRESS AVENUE SUITE 1250 AUSTIN, TX 78701				
NORTH AMERICAN IP HOLDINGS LLC,LEWISVILLE,TX,US	ST NETWORK SERVICES LLC	2011-03-31	031099/0844	2013-08-28
<b>Conveyance:</b> ASSIGNMENT OF ASSIGNORS INTEREST (SEE DOCUMENT FOR DETAILS).				
<b>Corresponent:</b> REED & SCARDINO LLP 301 CONGRESS AVENUE SUITE 1250 AUSTIN, TX 78701				
ST NETWORK SERVICES LLC,LEWISVILLE,TX,US	VELOCITA WIRELESS LLC	2009-03-19	031099/0751	2013-08-28
<b>Conveyance:</b> ASSIGNMENT OF ASSIGNORS INTEREST (SEE DOCUMENT FOR DETAILS).				
<b>Corresponent:</b> REED & SCARDINO LLP 301 CONGRESS AVENUE SUITE 1250 AUSTIN, TX 78701				
VELOCITA WIRELESS LLC,WOODBIDGE,NJ,US	BELL INDUSTRIES, INC.	2008-06-11	031099/0667	2013-08-28
<b>Conveyance:</b> ASSIGNMENT OF ASSIGNORS INTEREST (SEE DOCUMENT FOR DETAILS).				
<b>Corresponent:</b> REED & SCARDINO LLP 301 CONGRESS AVENUE SUITE 1250 AUSTIN, TX 78701				
NEWCASTLE PARTNERS L.P.,DALLAS,TX,US	BELL INDUSTRIES, INC.	2007-03-12	019009/0529	2007-03-14
	BELL INDUSTRIES, INC.	2007-03-12		
<b>Conveyance:</b> SECURITY AGREEMENT				
<b>Corresponent:</b> RANDY M. FRIEDBERG, ESQ. OLSHAN GRUNDMAN FROME ROSENSZWEIG ET AL PARK AVENUE TOWER 65 EAST 55TH STREET NEW YORK, NY 10022				
BELL INDUSTRIES INC.,INDIANAPOLIS,IN,US	SKYTEL CORP.	2007-01-31	031099/0562	2013-08-28
<b>Conveyance:</b> ASSIGNMENT OF ASSIGNORS INTEREST (SEE DOCUMENT FOR DETAILS).				
<b>Corresponent:</b> REED & SCARDINO LLP 301 CONGRESS AVENUE SUITE 1250 AUSTIN, TX 78701				
WELLS FARGO FOOTHILL INC. AS AGENT,SANTA MONICA,CA,US	BELL INDUSTRIES, INC., A CALIFORNIA CORPORATION	2007-01-31	018826/0503	2007-01-31
	BELL INDUSTRIES, INC., A MINNESOTA CORPORATION	2007-01-31		
<b>Conveyance:</b> PATENT SECURITY AGREEMENT				
<b>Corresponent:</b> PAUL HASTINGS JANOFSKY & WALKER LLP 515 SOUTH FLOWER STREET, 25TH FLOOR LOS ANGELES, CA 90071				



SKYTEL CORP.,ASHBURN,VA,US	SKYTEL COMMUNICATIONS, INC.	2004-12-31	018797/0318	2007-01-24
<b>Conveyance:</b> MERGER (SEE DOCUMENT FOR DETAILS).				
<b>Corresponent:</b> EDEN STRIGHT 1515 COURTHOUSE ROAD, SUITE 500 ARLINGTON, VA 22201-2909				
SKYTEL COMMUNICATIONS INC.,JACKSON,MS,US	MOBILE TELECOMMUNICATION TECHNOLOGIES CORP. DBA MOBILE TELECOMMUNICATION TECHNOLOGIES (MTEL)	1998-12-14	031804/0065	2013-11-20
<b>Conveyance:</b> CORRECTIVE ASSIGNMENT TO CORRECT THE SPELLING OF THE NAME OF THE ASSIGNEE PREVIOUSLY RECORDED ON REEL 031122, FRAME 0240. ASSIGNORS HEREBY CONFIRMS THE NAME OF THE ASSIGNEE IS SKYTEL COMMUNICATIONS, INC.				
<b>Corresponent:</b> REED & SCARDINO LLP 301 CONGRESS AVENUE SUITE 1250 AUSTIN, TEXAS 78701				
SKYTEL COMMUNICATIONS INC.,JACKSON,MS,US	MOBILE TELECOMMUNICATION TECHNOLOGIES CORP. DBA MOBILE TELECOMMUNICATION TECHNOLOGIES (MTEL)	1998-12-14	031122/0240	2013-08-28
<b>Conveyance:</b> CORRECTIVE ASSIGNMENT TO CORRECT THE NAME OF THE ASSIGNOR PREVIOUSLY RECORDED ON REEL 009657 FRAME 0936. ASSIGNOR(S) HEREBY CONFIRMS THE ASSIGNOR'S NAME IS MOBILE TELECOMMUNICATION TECHNOLOGIES CORP. DBA MOBILE TELECOMMUNICATION TECHNOLOGIES (MTEL).				
<b>Corresponent:</b> REED & SCARDINO LLP 301 CONGRESS AVENUE SUITE 1250 AUSTIN, TX 78701				
SKYTEL COMMUNICATIONS INC.,JACKSON,MS,US	MOBILE TELECOMMUNICATION TECHNOLOGIES (NTEL)	1998-12-14	009657/0936	1998-12-22
<b>Conveyance:</b> ASSIGNMENT OF ASSIGNORS INTEREST (SEE DOCUMENT FOR DETAILS).				
<b>Corresponent:</b> FINNEGAN, HENDERSON, FARABOW ETAL. JOHN M. ROMARY 1300 I STREET, N.W. WASHINGTON, DC 20005-3315				
MOBILE TELECOMMUNICATION TECHNOLOGIES,JACKSON, MS,US	PINTER, GREGORY J.	1996-07-16	008218/0879	1996-09-05
<b>Conveyance:</b> ASSIGNMENT OF ASSIGNORS INTEREST (SEE DOCUMENT FOR DETAILS).				
<b>Corresponent:</b> FINNEGAN, HENDERSON, FARABOW, GARRETT & DUNNER, L.L.P. ROBERT A. CAHILL 1300 I STREET, N.W. WASHINGTON, D.C. 20005-3315				

**Maintenance Status (US):** CC

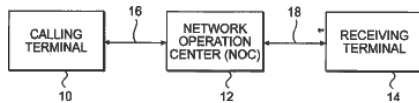
**Litigation (US):** 2016-01-04 2016 Mobile Telecommunications Technologies, LLC Google Inc. E.D. Texas 2:16cv00002 | 2015-12-31 2015 Mobile Telecommunications Technologies, LLC Microsoft Corporation E.D. Texas 2:15cv02122 | 2015-12-31 2015 Mobile Telecommunications Technologies, LLC Google Inc. E.D. Texas 2:15cv02123 | 2014-09-15 2014 Mobile Telecommunications Technologies, LLC AT&T Mobility LLC AT&T Inc E.D. Texas 2:14cv00897 | 2013-04-02 2013 MobileTelecommunications Technologies, LLC Samsung Telecommunications America, LLC E.D. Texas 2:13cv00259 | 2013-04-02 2013 Mobile Telecommunications Technologies, LLC Apple, Inc. E.D. Texas 2:13cv00258 | 2012-05-29 2012 Mobile Telecommunications Technbologies, LLC Research in Motion Corporation N.D. Texas 3:12cv01652

**Opposition (EP):**

**License (EP):**

**EPO Procedural Status:**

**Front Page Drawing:**



**Assignee - Current US:** MOBILE TELECOMMUNICATIONS TECHNOLOGIES LLC



Copyright 2007-2016 THOMSON REUTERS

USPTO Maintenance Report					
Patent Bibliographic Data				02/12/2016 10:01 PM	
Patent Number:	5894506	Application Number:	08708696		
Issue Date:	04/13/1999	Filing Date:	09/05/1996		
Title:	METHOD AND APPARATUS FOR GENERATING AND COMMUNICATING MESSAGES BETWEEN SUBSCRIBERS TO AN ELECTRONIC MESSAGING NETWORK				
Status:	4th, 8th and 12th year fees paid			Entity:	LARGE
Window Opens:	N/A	Surcharge Date:	N/A	Expiration:	N/A
Fee Amt Due:	Window not open	Surchg Amt Due:	Window not open	Total Amt Due:	Window not open
Fee Code:					
Surcharge Fee Code:					
Most recent events (up to 7):	10/13/2010 10/13/2006 11/26/2002 11/26/2002 10/30/2002 10/11/2002	Payment of Maintenance Fee, 12th Year, Large Entity. Payment of Maintenance Fee, 8th Year, Large Entity. Payor Number Assigned. Payer Number De-assigned. Maintenance Fee Reminder Mailed. Payment of Maintenance Fee, 4th Year, Large Entity. --- End of Maintenance History ---			
Address for fee purposes:	COMPUTER PACKAGES, INC. 414 HUNGERFORD DRIVE ROCKVILLE MD 20850				