



US00555999A

# United States Patent [19]

[11] Patent Number: **5,559,999**

Maturi et al.

[45] Date of Patent: **Sep. 24, 1996**

[54] **MPEG DECODING SYSTEM INCLUDING TAG LIST FOR ASSOCIATING PRESENTATION TIME STAMPS WITH ENCODED DATA UNITS**

[75] Inventors: **Greg Maturi, Tracy; David R. Auld; Darren Neuman**, both of San Jose, all of Calif.

[73] Assignee: **LSI Logic Corporation**, Milpitas, Calif.

[21] Appl. No.: **303,444**

[22] Filed: **Sep. 9, 1994**

[51] Int. Cl.<sup>6</sup> ..... **G06F 13/372**

[52] U.S. Cl. .... **395/550; 348/7; 348/10; 370/94.2; 370/110.1; 395/182.18; 395/200.17**

[58] Field of Search ..... **395/200.17, 550, 395/182.18, 250; 348/7, 512, 10; 370/110.1, 94.2**

[56] **References Cited**

**U.S. PATENT DOCUMENTS**

4,241,398	12/1980	Carl	.....	395/200.17
5,287,182	2/1994	Haskell et al.	.....	348/500
5,396,497	3/1995	Veltman	.....	370/100.1
5,442,390	8/1995	Hooper et al.	.....	348/7
5,448,568	9/1995	Delpuch et al.	.....	372/94.2

Primary Examiner—Ken S. Kim

Attorney, Agent, or Firm—Poms, Smith, Lande & Rose

[57] **ABSTRACT**

A Motion Picture Experts Group (MPEG) multiplexed data bitstream includes encoded video and audio data units, which are prefixed with headers including Presentation Time Stamps (PTS) indicating desired presentation times for the respective data units. The data units are decoded, and presented at a fixed time after decoding, such that the fixed time can be subtracted from the PTS to provide a desired decoding time. The bitstream is parsed, the video and audio headers are stored in video and audio header memories, and the associated video and audio data units are stored in video and audio channel memories respectively. A first interrupt is generated each time a header is stored, and a host microcontroller responds by storing the PTS from the header and the starting address of the corresponding data unit in the channel memory as an entry in a list. A second interrupt is generated each time a data unit is decoded, and the host microcontroller responds by accessing the list using the starting address of the data unit to obtain the corresponding PTS and thereby the desired decoding time. Decoding and presentation are synchronized by comparing the desired decoding time with a system clock time. If the desired decoding time is later than the system clock time by more than one presentation (frame) time period for the data unit, presentation of the data unit is skipped. If the desired decoding time is earlier than the system clock time by more than the presentation time period, presentation of the data unit is repeated.

26 Claims, 4 Drawing Sheets

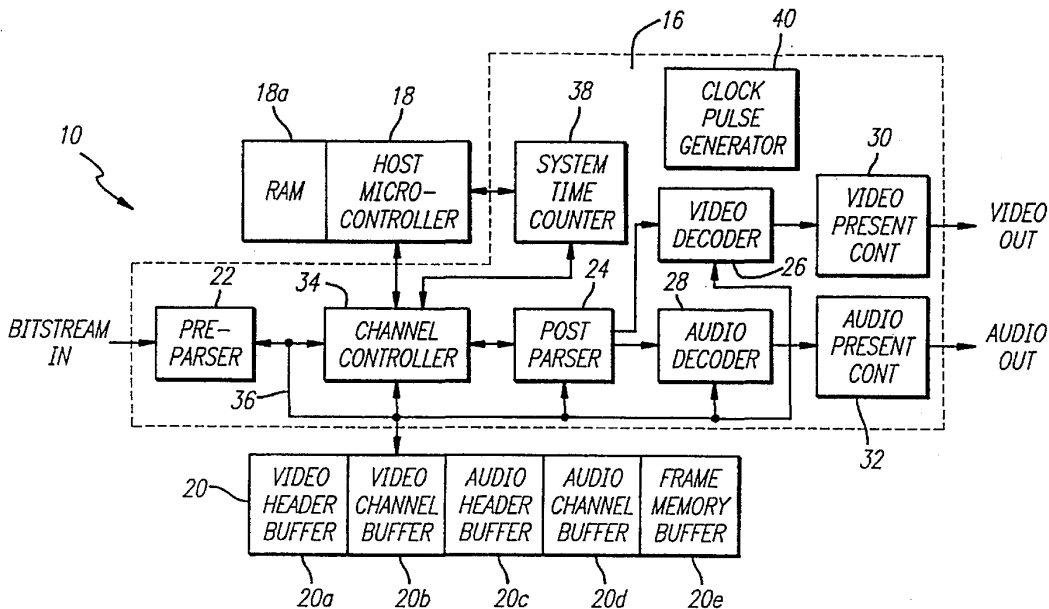

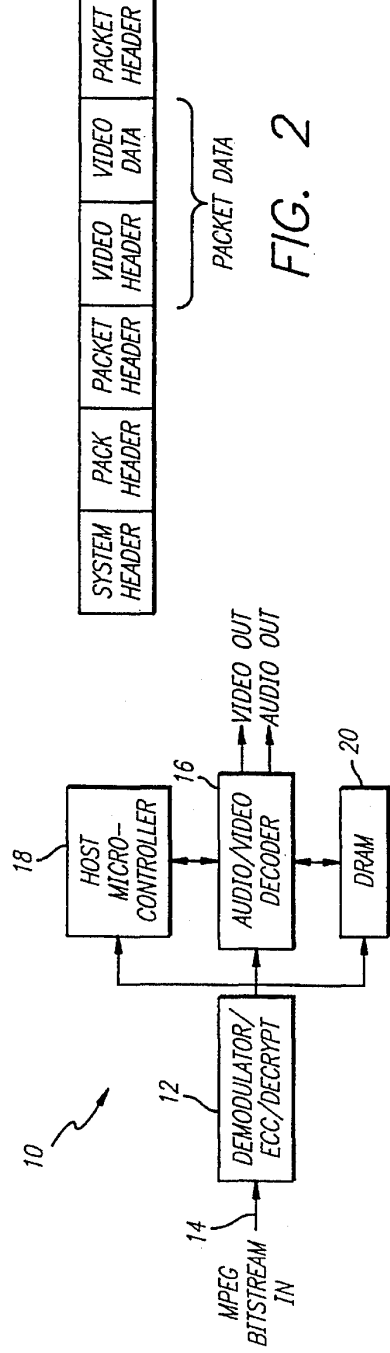

FIG. 1

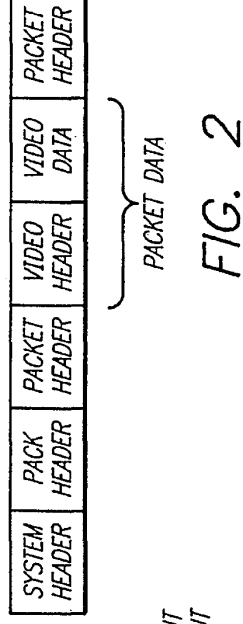

FIG. 2

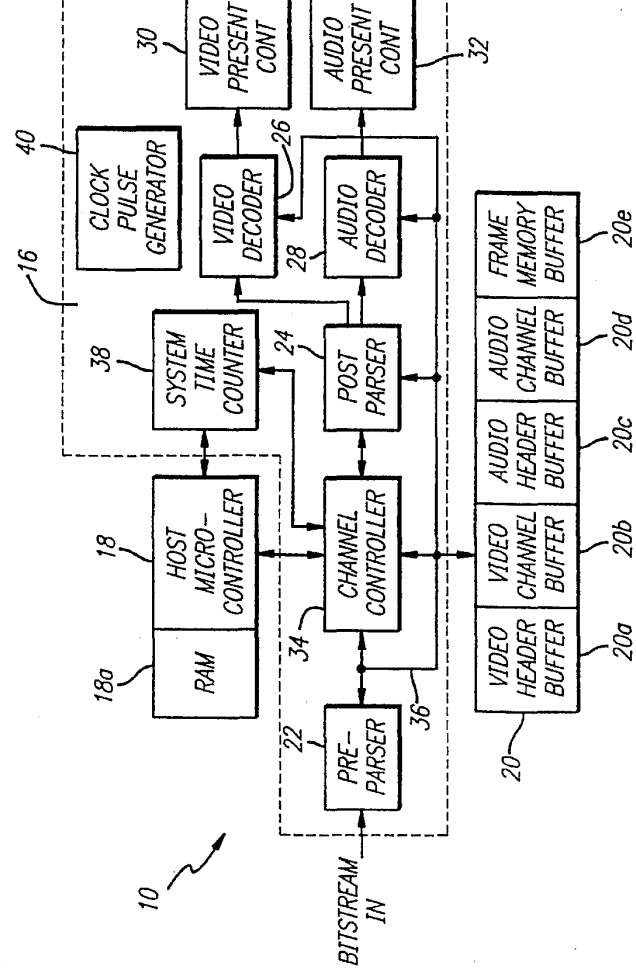
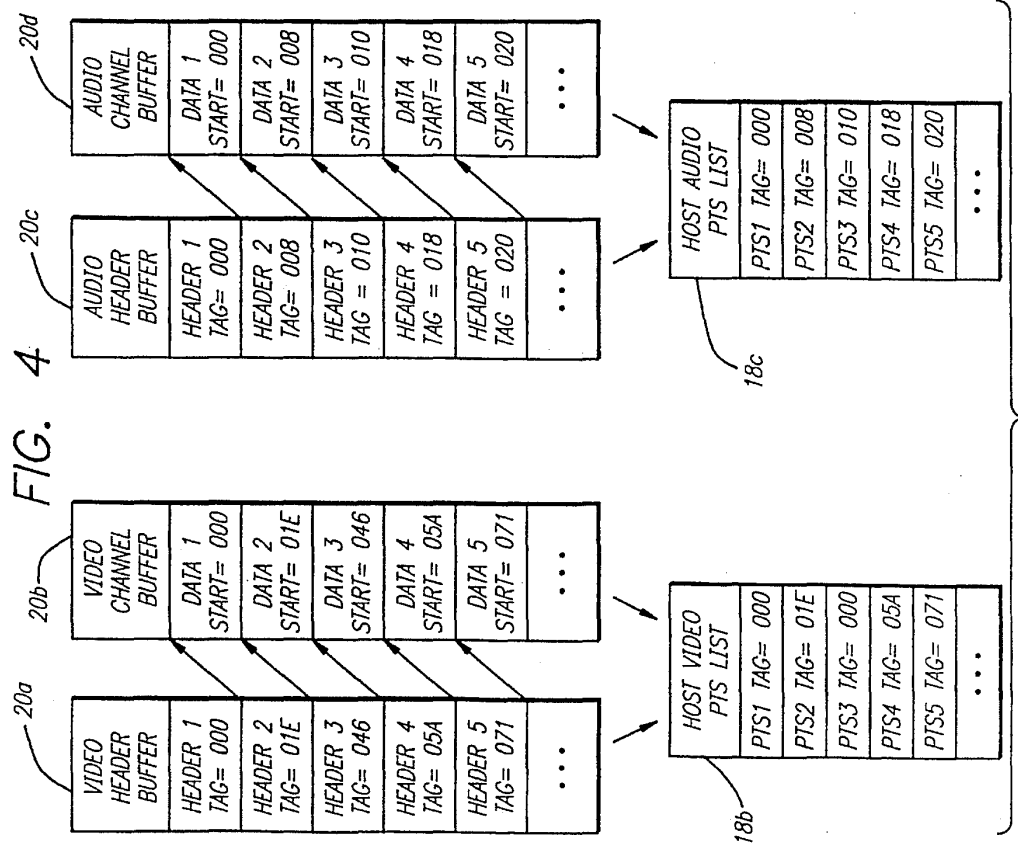

FIG. 3



**FIG. 5**

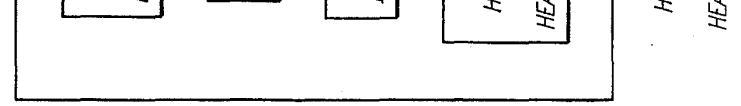

FIG. 6

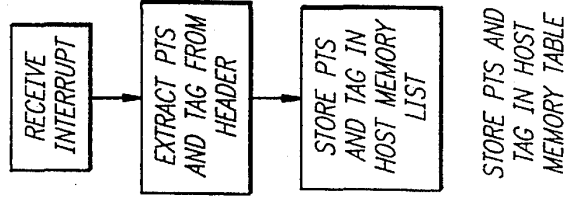

FIG. 7

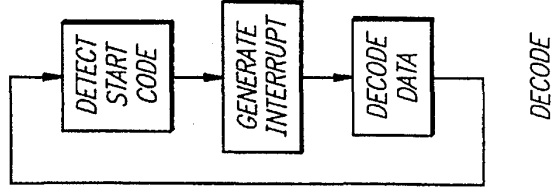

FIG. 8

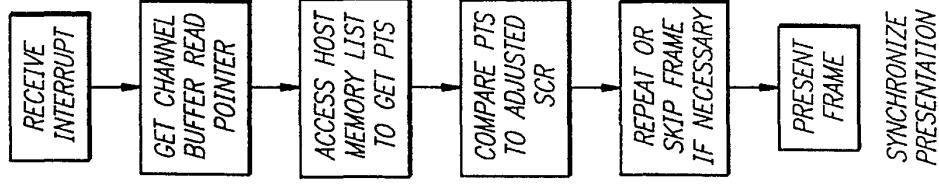

FIG. 9

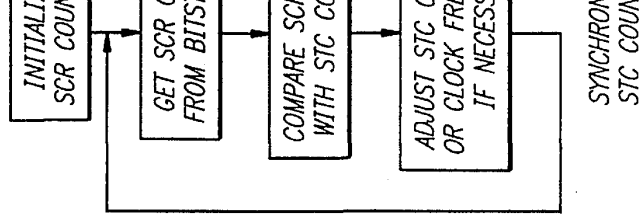

FIG. 10

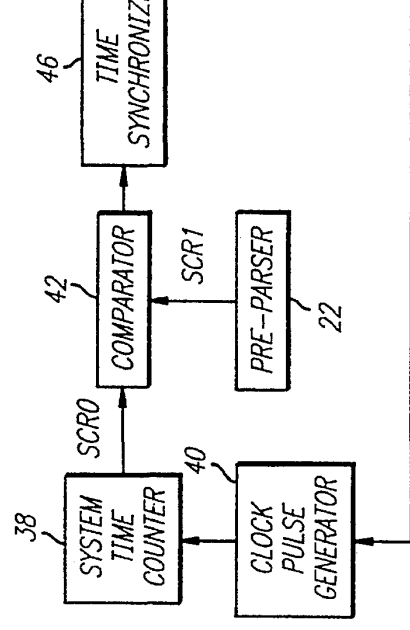
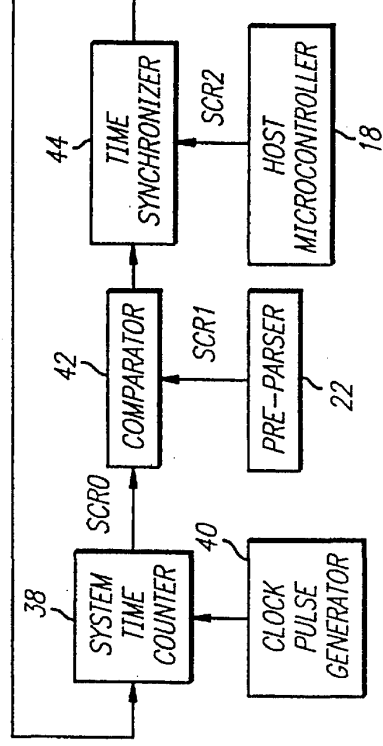

FIG. 11

# Explore Litigation Insights

Docket Alarm provides insights to develop a more informed litigation strategy and the peace of mind of knowing you're on top of things.

## Real-Time Litigation Alerts



Keep your litigation team up-to-date with **real-time alerts** and advanced team management tools built for the enterprise, all while greatly reducing PACER spend.

Our comprehensive service means we can handle Federal, State, and Administrative courts across the country.

## Advanced Docket Research



With over 230 million records, Docket Alarm's cloud-native docket research platform finds what other services can't. Coverage includes Federal, State, plus PTAB, TTAB, ITC and NLRB decisions, all in one place.

Identify arguments that have been successful in the past with full text, pinpoint searching. Link to case law cited within any court document via Fastcase.

## Analytics At Your Fingertips



Learn what happened the last time a particular judge, opposing counsel or company faced cases similar to yours.

Advanced out-of-the-box PTAB and TTAB analytics are always at your fingertips.

## API

Docket Alarm offers a powerful API (application programming interface) to developers that want to integrate case filings into their apps.

## LAW FIRMS

Build custom dashboards for your attorneys and clients with live data direct from the court.

Automate many repetitive legal tasks like conflict checks, document management, and marketing.

## FINANCIAL INSTITUTIONS

Litigation and bankruptcy checks for companies and debtors.

## E-DISCOVERY AND LEGAL VENDORS

Sync your system to PACER to automate legal marketing.