



US005812789A

United States Patent [19]
Diaz et al.

[11] **Patent Number:** **5,812,789**
[45] **Date of Patent:** **Sep. 22, 1998**

- [54] **VIDEO AND/OR AUDIO DECOMPRESSION AND/OR COMPRESSION DEVICE THAT SHARES A MEMORY INTERFACE**
- [75] Inventors: **Raul Zegers Diaz**, Palo Alto; **Jefferson Eugene Owen**, Fremont, both of Calif.
- [73] Assignee: **STMicroelectronics, Inc.**, Carrollton, Tex.
- [21] Appl. No.: **702,911**
- [22] Filed: **Aug. 26, 1996**
- [51] **Int. Cl.⁶** **G06F 17/00**
- [52] **U.S. Cl.** **395/200.77**
- [58] **Field of Search** 395/200.77, 200.82, 395/507, 890, 729; 348/402, 407, 10

- Galbi, D. et al., "An MPEG-1 Audio/Video Decoder With Run-Length Compressed Antialiased Video Overlays," 1995 IEEE International Solid-State Circuits Conference, pp. 286-287, 381.
- Maturi, G., "Single Chip MPEG Audio Decoder," IEEE Transactions on Consumer Electronics, vol. 38, No. 3, Aug. 1992, pp. 348-356.
- Butler, B. and T. Mace, "The Great Leap Forward," *PC Magazine*, Oct. 11, 1994, pp. 241-244, 246, 248, 250, 253-254, 256, 260-261, 264, 266-268, 273-275, 278.
- Doquilo, J., "Symmetric Multiprocessing Servers: Scaling the Performance Wall," *Infoworld*, Mar. 27, 1995, pp. 82-85, 88-92.
- Video Electronics Standards Association, "VESA Unified Memory Architecture Hardware Specifications Proposal," Version: 1.0p, Oct. 31, 1995, pp. 1-38.
- Video Electronics Standards Association, "VESA Unified Memory Architecture VESA BIOS Extensions VUMA-SBE Proposal," Version: 1.0p, Nov. 1, 1995, pp. 1-26.
- King, A., *Inside Windows 95*, Microsoft Press, Redmond, Washington, 1994, pp. 85-90.
- "MPEG Video Overview," *SGS-Thomson Microelectronics Technical Note*, Apr. 1992, pp. 1-4.
- "On the Bus Arbitration for MPEG 2 Video Decoder"; VLSI Tech, System and Application, 1995 Symposium.
- "A Low Cost Graphics and Multimedia Workstation Chip Set"; IEEE Micro, 1994.

[56] **References Cited**

U.S. PATENT DOCUMENTS

4,774,660	9/1988	Conforti	395/729
4,894,565	1/1990	Marquardt	395/729
5,027,400	6/1991	Baji et al.	348/10
5,371,893	12/1994	Price et al.	395/729
5,459,519	10/1995	Scalise et al.	348/431
5,522,080	5/1996	Harney et al.	395/729
5,557,538	9/1996	Retter et al.	348/402
5,598,525	1/1997	Nally et al.	395/507
5,621,893	4/1997	Joh	395/200.82
5,623,672	4/1997	Poppat	395/729

FOREIGN PATENT DOCUMENTS

0 673 171 A2 9/1995 European Pat. Off. .

OTHER PUBLICATIONS

- Bheda, H. and P. Srinivasan, "A High-Performance Cross-Platform MPEG Decoder," *Digital Video Compression on Personal Computers: Algorithms and Technologies*. SPIE Proceedings, Feb. 7-8, 1994, Vo. 2187, pp. 241-248.
- Bursky, D., "Highly Integrated Controller Eases MPEG-2 Adoption," *Electronic Design*, Aug. 21, 1995, vol. 43, No. 17, pp. 141-142.

- King, A., *Inside Windows 95*, Microsoft Press, Redmond, Washington, 1994, pp. 85-90.
 - "MPEG Video Overview," *SGS-Thomson Microelectronics Technical Note*, Apr. 1992, pp. 1-4.
 - "On the Bus Arbitration for MPEG 2 Video Decoder"; VLSI Tech, System and Application, 1995 Symposium.
 - "A Low Cost Graphics and Multimedia Workstation Chip Set"; IEEE Micro, 1994.
- Primary Examiner*—Ellis B. Ramirez
Attorney, Agent, or Firm—David V. Carlson; Theodore E. Galanthay; Lisa K. Jorgenson

[57] **ABSTRACT**

An electronic system that contains a first device that requires a memory interface and video and/or audio decompression and/or compression device that shares a memory interface and memory with the first device while still permitting the video and/or audio decompression and/or compression device to operate in real time is disclosed.

33 Claims, 5 Drawing Sheets

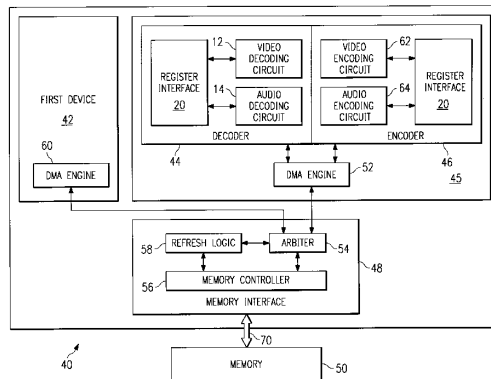

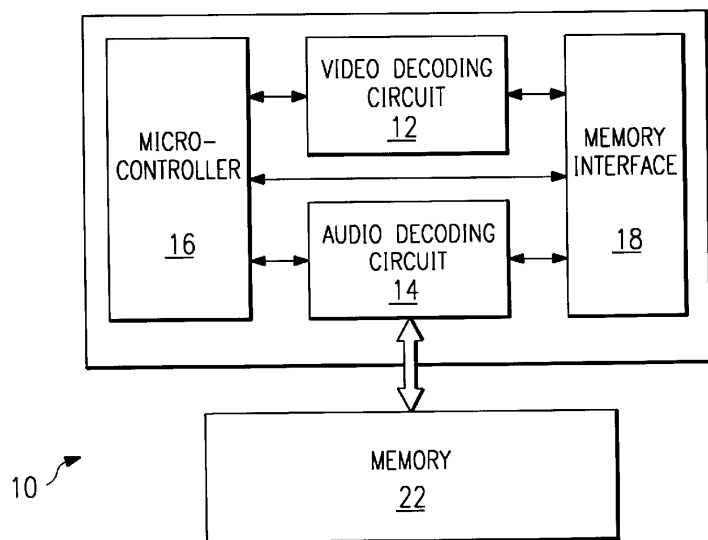

FIG. 1a
(PRIOR ART)

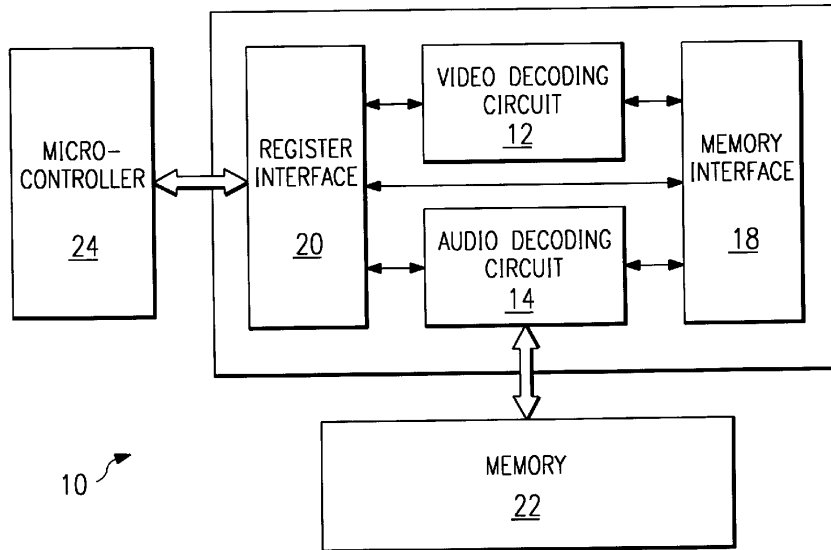

FIG. 1b
(PRIOR ART)

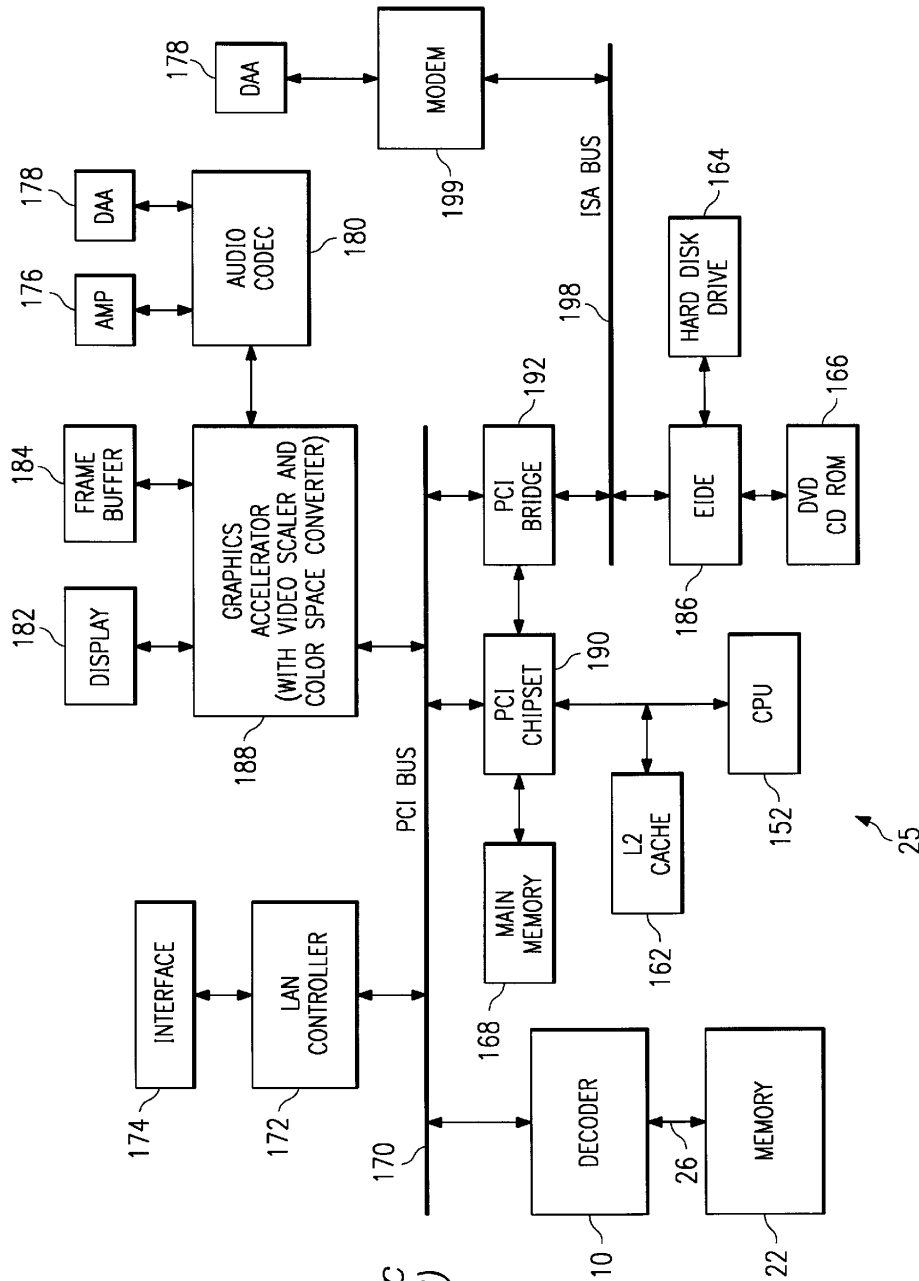
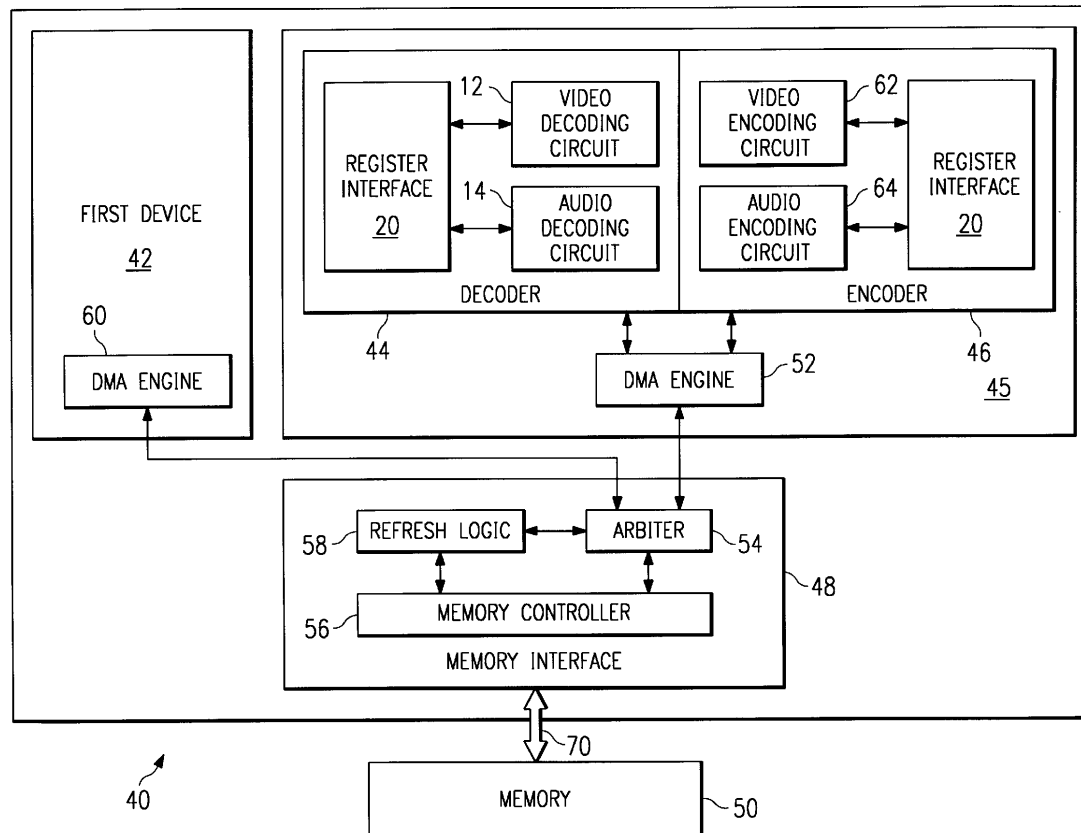

FIG. 1C
(PRIOR ART)

FIG. 2



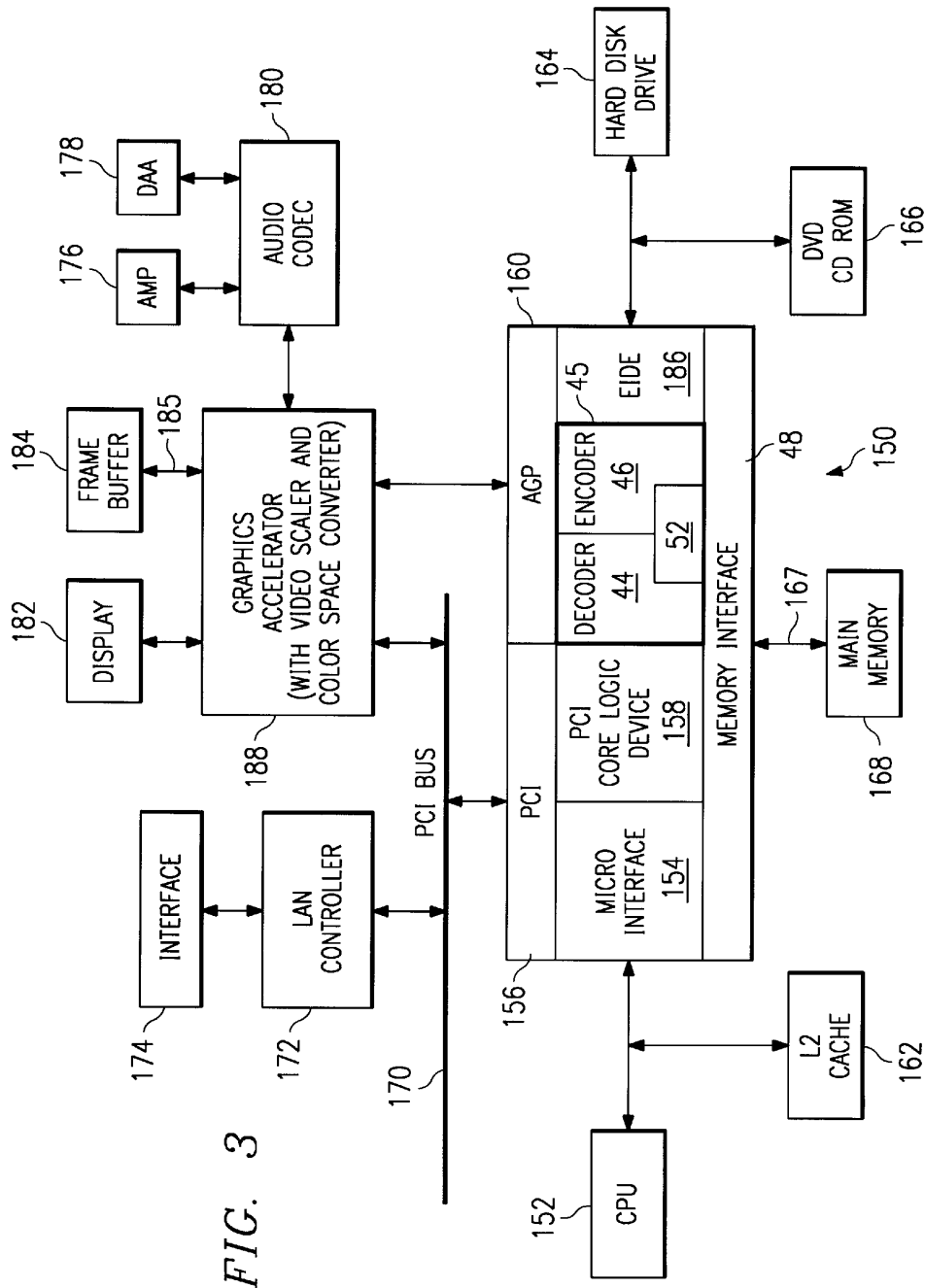

FIG. 3

Explore Litigation Insights

Docket Alarm provides insights to develop a more informed litigation strategy and the peace of mind of knowing you're on top of things.

Real-Time Litigation Alerts



Keep your litigation team up-to-date with **real-time alerts** and advanced team management tools built for the enterprise, all while greatly reducing PACER spend.

Our comprehensive service means we can handle Federal, State, and Administrative courts across the country.

Advanced Docket Research



With over 230 million records, Docket Alarm's cloud-native docket research platform finds what other services can't. Coverage includes Federal, State, plus PTAB, TTAB, ITC and NLRB decisions, all in one place.

Identify arguments that have been successful in the past with full text, pinpoint searching. Link to case law cited within any court document via Fastcase.

Analytics At Your Fingertips



Learn what happened the last time a particular judge, opposing counsel or company faced cases similar to yours.

Advanced out-of-the-box PTAB and TTAB analytics are always at your fingertips.

API

Docket Alarm offers a powerful API (application programming interface) to developers that want to integrate case filings into their apps.

LAW FIRMS

Build custom dashboards for your attorneys and clients with live data direct from the court.

Automate many repetitive legal tasks like conflict checks, document management, and marketing.

FINANCIAL INSTITUTIONS

Litigation and bankruptcy checks for companies and debtors.

E-DISCOVERY AND LEGAL VENDORS

Sync your system to PACER to automate legal marketing.