



US 20050160199A1

(19) **United States**

(12) **Patent Application Publication** (10) **Pub. No.: US 2005/0160199 A1**

Tasler

(43) **Pub. Date: Jul. 21, 2005**

(54) **FLEXIBLE INTERFACE**

Publication Classification

(76) Inventor: **Michael Tasler, Wurzburg (DE)**

(51) **Int. Cl.⁷ G06F 3/00**

(52) **U.S. Cl. 710/16**

Correspondence Address:

**GLENN PATENT GROUP
3475 EDISON WAY, SUITE L
MENLO PARK, CA 94025 (US)**

(57) **ABSTRACT**

(21) Appl. No.: **11/078,778**

(22) Filed: **Mar. 11, 2005**

An interface device (10) provides fast data communication between a host device with input/output interfaces and a data transmit/receive device, wherein the interface device (10) comprises a processor means (13), a memory means (14), a first connecting device (12) for interfacing the host device with the interface device, and a second connecting device (15) for interfacing the interface device (10) with the data transmit/receive device. The interface device (10) is configured by the processor means (13) and the memory means (14) in such a way that, when receiving an inquiry from the host device via the first connecting device (12) as to the type of a device attached to the host device, regardless of the type of the data transmit/receive device, the interface device sends a signal to the host device via the first connecting device (12) which signals to the host device that it is communicating with an input/output device.

Related U.S. Application Data

(63) Continuation of application No. 10/219,105, filed on Aug. 15, 2002, now Pat. No. 6,895,449.

Foreign Application Priority Data

Mar. 4, 1997 (DE)..... 19708755.8
Mar. 3, 1998 (WO)..... PCT/EP98/01187

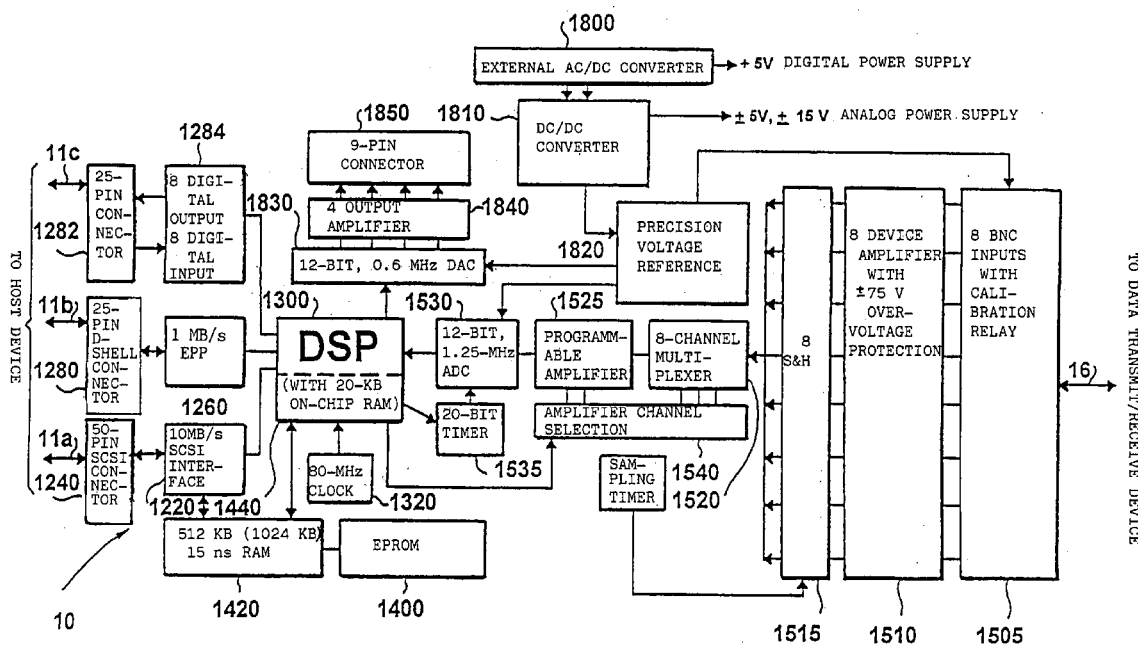

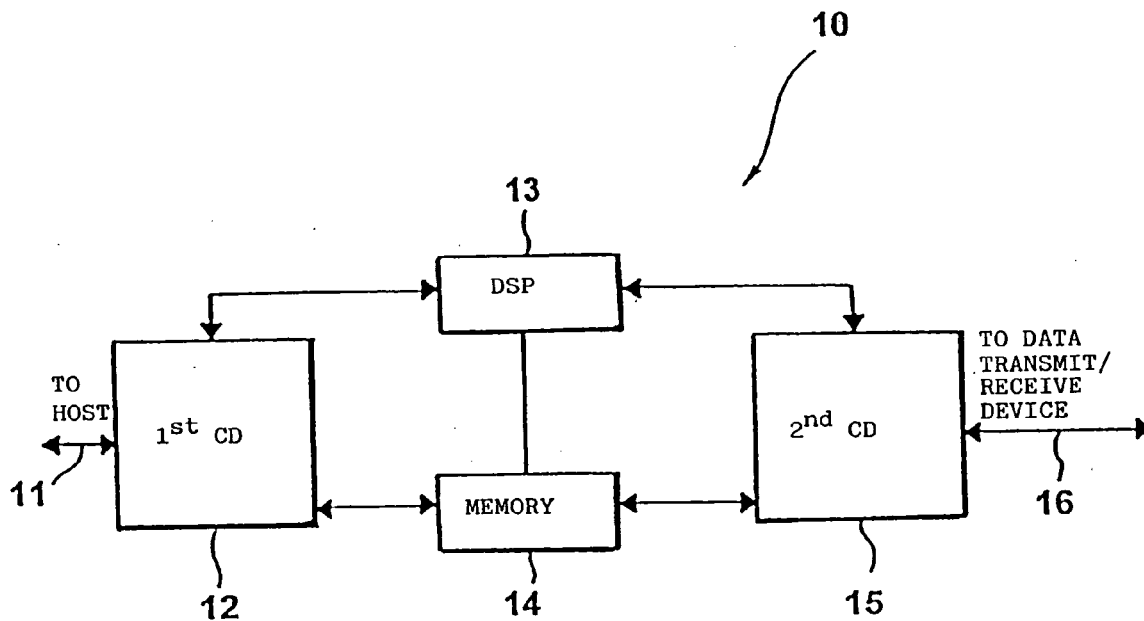

FIG. 1

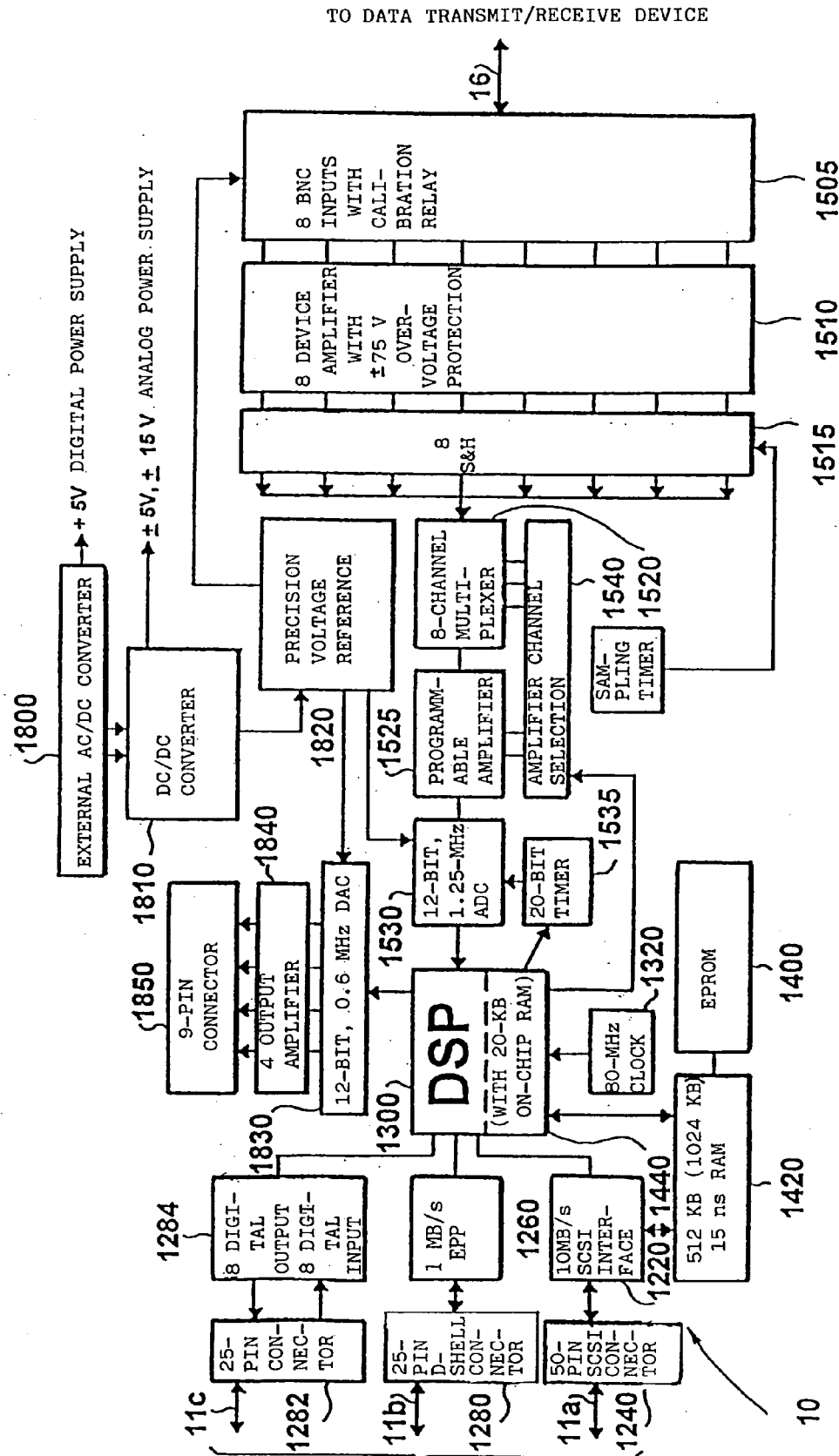

FIG. 2

FLEXIBLE INTERFACE

[0001] The present invention relates to the transfer of data and in particular to interface devices for communication between a computer or host device and a data transmit/receive device from which data is to be acquired or with which two-way communication is to take place.

[0002] Existing data acquisition systems for computers are very limited in their areas of application. Generally such systems can be classified into two groups.

[0003] In the first group host devices or computer systems are attached by means of an interface to a device whose data is to be acquired. The interfaces of this group are normally standard interfaces which, with specific driver software, can be used with a variety of host systems. An advantage of such interfaces is that they are largely independent of the host device. However, a disadvantage is that they generally require very sophisticated drivers which are prone to malfunction and which limit data transfer rates between the device connected to the interface and the host device and vice versa. Further, it is often very difficult to implement such interfaces for portable systems and they offer few possibilities for adaptation with the result that such systems offer little flexibility.

[0004] The devices from which data is to be acquired cover the entire electrical engineering spectrum. In a typical case, it is assumed that a customer who operates, for example, a diagnostic radiology system in a medical engineering environment reports a fault. A field service technician of the system manufacturer visits the customer and reads system log files generated by the diagnostic radiology system by means of a portable computer or laptop for example. If the fault cannot be localized or if the fault is intermittent, it will be necessary for the service technician to read not only an error log file but also data from current operation. It is apparent that in this case fast data transfer and rapid data analysis are necessary.

[0005] Another case requiring the use of an interface could be, for example, when an electronic measuring device, e.g. a multimeter, is attached to a computer system to transfer the data measured by the multimeter to the computer. Particularly when long-term measurements or large volumes of data are involved it is necessary for the interface to support a high data transfer rate.

[0006] From these randomly chosen examples it can be seen that an interface may be put to totally different uses. It is therefore desirable that an interface be sufficiently flexible to permit attachment of very different electrical or electronic systems to a host device by means of the interface. To prevent operator error, it is also desirable that a service technician is not required to operate different interfaces in different ways for different applications but that, if possible, a universal method of operating the interface be provided for a large number of applications.

[0007] To increase the data transfer rates across an interface, the route chosen in the second group of data acquisition systems for the interface devices was to specifically match the interface very closely to individual host systems or computer systems. The advantage of this solution is that high data transfer rates are possible. However, a disadvantage

result that they generally cannot be used with other host systems or their use is very ineffective. Further, such types of interface have the disadvantage that they must be installed inside the computer casing to achieve maximum data transfer rates as they access the internal host bus system. They are therefore generally not suitable for portable host systems in the form of laptops whose minimum possible size leaves little internal space to plug in an interface card.

[0008] A solution to this problem is offered by the interface devices of IOtech (business address: 25971 Cannon Road, Cleveland, Ohio 44146, USA) which are suitable for laptops such as the WaveBook/512 (registered trademark). The interface devices are connected by means of a plug-in card, approximately the size of a credit card, to the PCMCIA interface which is now a standard feature in laptops. The plug-in card converts the PCMCIA interface into an interface known in the art as IEEE 1284. The said plug-in card provides a special printer interface which is enhanced as regards the data transfer rate and delivers a data transfer rate of approximately 2 MBps as compared with a rate of approx. 1 MBps for known printer interfaces. The known interface device generally consists of a driver component, a digital signal processor, a buffer and a hardware module which terminates in a connector to which the device whose data is to be acquired is attached. The driver component is attached directly to the enhanced printer interface thus permitting the known interface device to establish a connection between a computer and the device whose data is to be acquired.

[0009] In order to work with the said interface, an interface-specific driver must be installed on the host device so that the host device can communicate with the digital signal processor of the interface card. As described above, the driver must be installed on the host device. If the driver is a driver developed specifically for the host device, a high data transfer rate is achieved but the driver cannot be easily installed on a different host system. However, if the driver is a general driver which is as flexible as possible and which can be used on many host devices, compromises must be accepted with regard to the data transfer rate.

[0010] Particularly in an application for multi-tasking systems in which several different tasks such as data acquisition, data display and editing are to be performed quasi-simultaneously, each task is normally assigned a certain priority by the host system. A driver supporting a special task requests the central processing system of the host device for processor resources in order to perform its task. Depending on the particular priority assignment method and on the driver implementation, a particular share of processor resources is assigned to a special task in particular time slots. Conflicts arise if one or more drivers are implemented in such a way that they have the highest priority by default, i.e. they are incompatible, as happens in practice in many applications. It may occur that both drivers are set to highest priority which, in the worst case, can result in a system crash.

[0011] EP 0685799 A1 discloses an interface by means of which several peripheral devices can be attached to a bus. An interface is connected between the bus of a host device and various peripheral devices. The interface comprises a finite state machine and several branches each of which is

known interface device provides optimal matching between a host device and a specific peripheral device.

[0012] The specialist publication IBM Technical Disclosure Bulletin, Vol. 38, No. 05, page 245; "Communication Method between Devices through FDD Interface" discloses an interface which connects a host device to a peripheral device via a floppy disk drive interface. The interface consists in particular of an address generator, an MFM encoder/decoder, a serial/parallel adapter and a format signal generator. The interface makes it possible to attach not only a floppy disk drive but also a further peripheral device to the FDD host controller of a host device. The host device assumes that a floppy disk drive is always attached to its floppy disk drive controller and communication is initiated if the address is correct. However, this document contains no information as to how communication should be possible if the interface is connected to a multi-purpose interface instead of to a floppy disk drive controller.

[0013] It is the object of the present invention to provide an interface device for communication between a host device and a data transmit/receive device whose use is host device-independent and which delivers a high data transfer rate.

[0014] This object is achieved by an interface device according to claim 1 or 12 and by a method according to claim 15.

[0015] The present invention is based on the finding that both a high data transfer rate and host device-independent use can be achieved if a driver for an input/output device customary in a host device, normally present in most commercially available host devices, is utilized. Drivers for input/output devices customary in a host device which are found in practically all host devices are, for example, drivers for hard disks, for graphics devices or for printer devices. As however the hard disk interfaces in common host devices which can be, for example, IBM PCs, IBM-compatible PCs, Commodore PCs, Apple computers or even workstations, are the interfaces with the highest data transfer rate, the hard disk driver is utilized in the preferred embodiment of the interface device of the present invention. Drivers for other storage devices such as floppy disk drives, CD-ROM drives or tape drives could also be utilized in order to implement the interface device according to the present invention.

[0016] As described in the following, the interface device according to the present invention is to be attached to a host device by means of a multi-purpose interface of the host device which can be implemented, for example, as an SCSI interface or as an enhanced printer interface. Multi-purpose interfaces comprise both an interface card and specific driver software for the interface card. The driver software can be designed so that it can replace the BIOS driver routines. Communication between the host device and the devices attached to the multi-purpose interface then essentially takes place by means of the specific driver software for the multi-purpose interface and no longer primarily by means of BIOS routines of the host device. Recently however drivers for multi-purpose interfaces can also already be integrated in the BIOS system of the host device as, alongside classical input/output interfaces, multi-purpose interfaces are becoming increasingly common in host devices. It is of course also possible to use BIOS routines in parallel with the specific

[0017] The interface device according to the present invention comprises a processor means, a memory means, a first connecting device for interfacing the host device with the interface device, and a second connecting device for interfacing the interface device with the data transmit/receive device. The interface device is configured by the processor means and the memory means in such a way that the interface device, when receiving an inquiry from the host device via the first connecting device as to the type of a device attached to the host device, sends a signal, regardless of the type of the data transmit/receive device, to the host device via the first connecting device which signals to the host device that it is communicating with an input/output device. The interface device according to the present invention therefore simulates, both in terms of hardware and software, the way in which a conventional input/output device functions, preferably that of a hard disk drive. As support for hard disks is implemented as standard in all commercially available host systems, the simulation of a hard disk, for example, can provide host device-independent use. The interface device according to the present invention therefore no longer communicates with the host device or computer by means of a specially designed driver but by means of a program which is present in the BIOS system (Basic Input/Output System) and is normally precisely matched to the specific computer system on which it is installed, or by means of a specific program for the multi-purpose interface. Consequently, the interface device according to the present invention combines the advantages of both groups. On the one hand, communication between the computer and the interface takes place by means of a host device-specific BIOS program or by means of a driver program which is matched to the multi-purpose interface and which could be regarded as a "device-specific driver". On the other hand, the BIOS program or a corresponding multi-purpose interface program which operates one of the common input/output interfaces in host systems is therefore present in all host systems so that the interface device according to the present invention is host device-independent.

[0018] In the following, preferred embodiments of the present invention will be explained in more detail with reference to the drawings enclosed, in which:

[0019] FIG. 1 shows a general block diagram of the interface device according to the present invention; and

[0020] FIG. 2 shows a detailed block diagram of an interface device according to a preferred embodiment of the present invention.

[0021] FIG. 1 shows a general block diagram of an interface device 10 according to the present invention. A first connecting device 12 of the interface device 10 can be attached to a host device (not shown) via a host line 11. The first connecting device is attached both to a digital signal processor 13 and to a memory means 14. The digital signal processor 13 and the memory means 14 are also attached to a second connecting device 15 by means of bi-directional communication lines (shown for all lines by means of two directional arrows). The second connecting device can be attached by means of an output line 16 to a data transmit/receive device which is to receive data from the host device

Explore Litigation Insights

Docket Alarm provides insights to develop a more informed litigation strategy and the peace of mind of knowing you're on top of things.

Real-Time Litigation Alerts



Keep your litigation team up-to-date with **real-time alerts** and advanced team management tools built for the enterprise, all while greatly reducing PACER spend.

Our comprehensive service means we can handle Federal, State, and Administrative courts across the country.

Advanced Docket Research



With over 230 million records, Docket Alarm's cloud-native docket research platform finds what other services can't. Coverage includes Federal, State, plus PTAB, TTAB, ITC and NLRB decisions, all in one place.

Identify arguments that have been successful in the past with full text, pinpoint searching. Link to case law cited within any court document via Fastcase.

Analytics At Your Fingertips



Learn what happened the last time a particular judge, opposing counsel or company faced cases similar to yours.

Advanced out-of-the-box PTAB and TTAB analytics are always at your fingertips.

API

Docket Alarm offers a powerful API (application programming interface) to developers that want to integrate case filings into their apps.

LAW FIRMS

Build custom dashboards for your attorneys and clients with live data direct from the court.

Automate many repetitive legal tasks like conflict checks, document management, and marketing.

FINANCIAL INSTITUTIONS

Litigation and bankruptcy checks for companies and debtors.

E-DISCOVERY AND LEGAL VENDORS

Sync your system to PACER to automate legal marketing.