

(12) United States Patent
Wilhelm et al.

(10) Patent No.: US 6,176,116 B1
(45) Date of Patent: Jan. 23, 2001

(54) **CRIMPING TOOL FOR CRIMPING LEAD END SLEEVES AND THE LIKE**

1342312 * 9/1963 (FR) 81/313
 886259 1/1962 (GB) .
 1 324 253 7/1973 (GB) .

(75) Inventors: **Edgar Wilhelm**, Altersbach; **Horst Hofmann**, Unterschonau, both of (DE)

* cited by examiner

(73) Assignee: **Rennsteig Werkzeuge GmbH**, Viernau/Thueringen (DE)

Primary Examiner—Daniel C. Crane
 (74) *Attorney, Agent, or Firm*—Michael J. Striker

(*) Notice: Under 35 U.S.C. 154(b), the term of this patent shall be extended for 0 days.

(57) ABSTRACT

(21) Appl. No.: **09/334,296**

A crimping tool for crimping lead end sleeves, contact sockets, or plugs on the electrical conductors, two crimping jaws arranged in a tool head section for performing crimping, pivotably mounted and axially fixed in the tool head section, and forming a crimping aperture of adjustable cross-section, the crimping jaws on their outer peripheral surfaces receiving a pivot lever and are bringable into and out of a crimping position by a pivoting drive movement of the pivot lever, a toggle lever mechanism driven by the handles and effecting the pivoting drive movement of the pivot lever, for a force-stroke compensation between parts of a force transmission system, the crimping jaws in a region of their crimping profile being formed by a die surface and a sliding surface, the die surfaces of the crimping jaws forming a die profile of closed shape in all crimping position within an adjustable crimping range, the sliding surface of each of the crimping jaws being in planar contact with the die surface of an adjacent one of the crimping jaws, extending a plane of the adjacent die surface, the handles including a fixed handle formed as a compensating spring for force-stroke compensation between the parts of the force transmission system, and an elastic lever integrated and fixed in the fixed handle and mechanically linked with one lever arm of the toggle joint mechanism.

(22) Filed: **Jun. 16, 1999**

(51) **Int. Cl.⁷** **H01R 43/042**

(52) **U.S. Cl.** **72/409.12; 72/402; 81/313; 81/367; 81/427.5**

(58) **Field of Search** **72/409.12, 409.01, 72/402; 81/313, 427.5, 367**

(56) References Cited

U.S. PATENT DOCUMENTS

2,079,498	*	5/1937	Douglas	81/313
3,199,335		8/1965	Holmes et al. .		
3,203,078		8/1965	Ustin .		
3,330,148	*	7/1967	Hornung	72/409.12
3,459,029	*	8/1969	Rosenfeld	81/313
3,713,322	*	1/1973	Fischer	81/313
4,381,661	*	5/1983	Wiener	72/409.12
5,261,263		11/1993	Whitesell	72/402

FOREIGN PATENT DOCUMENTS

31 09 289 C2		8/1987	(DE) .
0 158 611 B1		7/1990	(EP) .

10 Claims, 2 Drawing Sheets

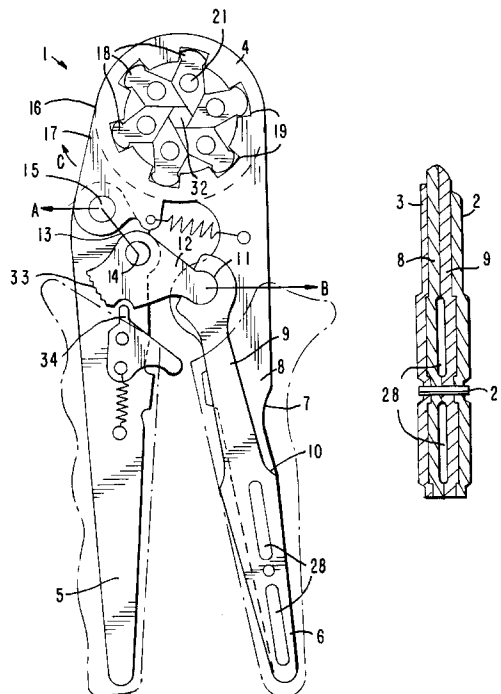

EDWARDS LIFESCIENCES EX 4447

FIG. 1

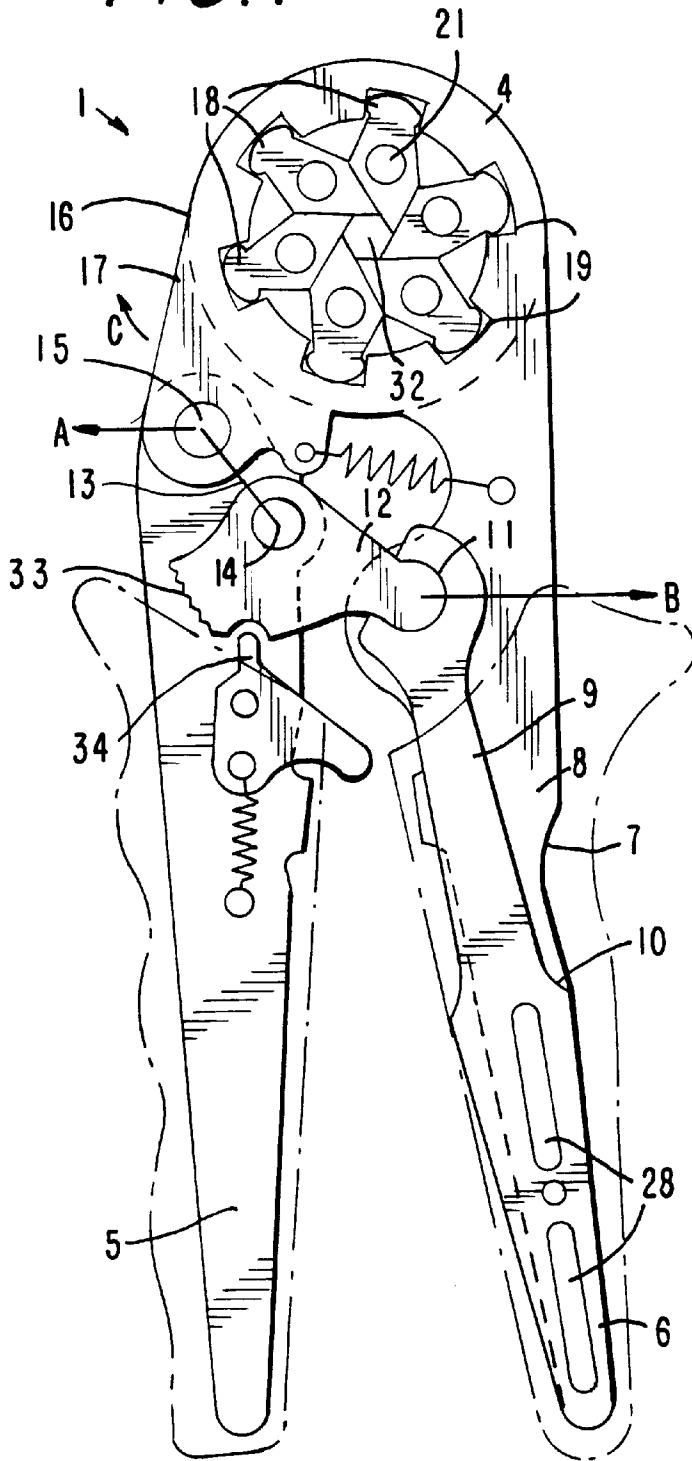
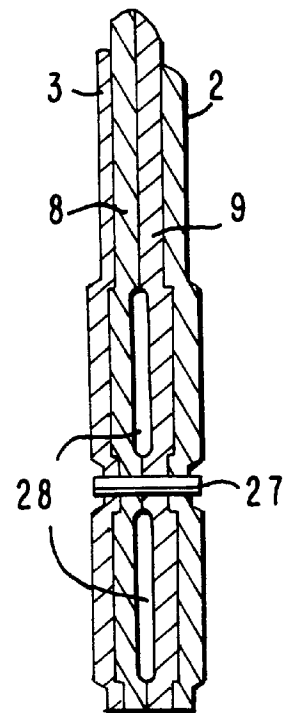
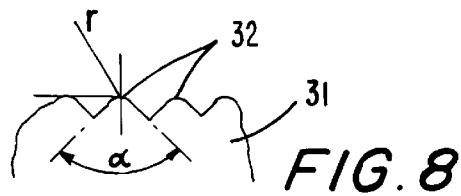
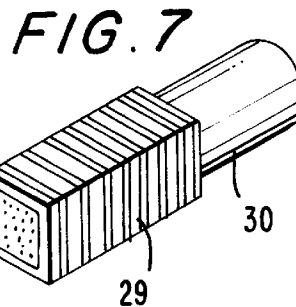
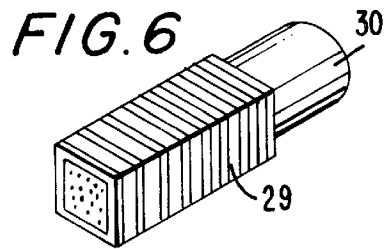
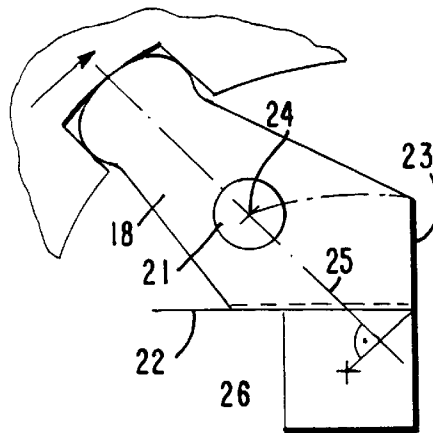
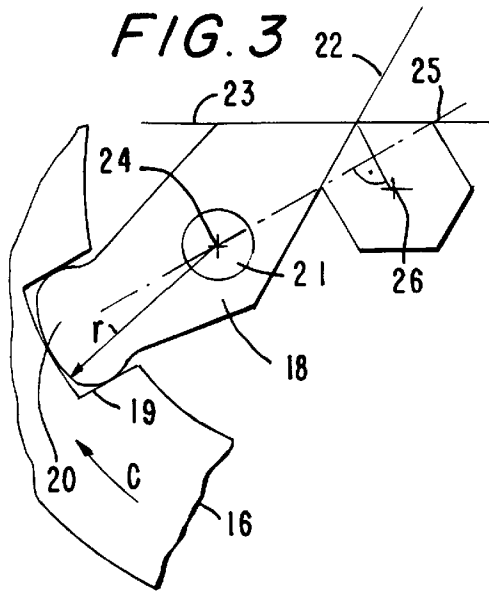

FIG. 2





CRIMPING TOOL FOR CRIMPING LEAD END SLEEVES AND THE LIKE

BACKGROUND OF THE INVENTION

The present invention relates to a crimping tool for crimping lead end sleeves, contact sockets or lugs onto electrical conductors. More particularly it relates to a crimping tool which has crimping jaws which are arranged in the tool head section, are enclosed by a pivot lever and can be moved centrally relative to one another by the pivoting drive movement of the pivot lever effected by a toggle joint mechanism and thereby brought into and, on the return stroke, out of the crimping position. Its jaw surfaces partially abut in their active region form, together with the adjacent crimping jaws, a crimping aperture of adjustable cross section. An elastic compensation, automatically actuated during the crimping process and effected by springs, is created between parts of the force transmission system in order to compensate for differently dimensioned die profiles and the resulting variable crimping stroke.

The compensation of the respective crimping stroke produced by the differently dimensioned die profiles within the drive mechanics of the crimping tool existing between the handles and the crimping jaws is already necessary in order to guarantee the uniformity and quality of the crimping within a given size range of lead end sleeves and electrical conductors and in order to prevent breakage of tool parts by possible overloading. In this respect, it is particularly advantageous to provide this compensation in a resilient and elastic manner, e.g. by a spring element, which has been found in practice to considerably improve and facilitate the use of the crimping tools.

The crimping tool is ensured against possible premature opening of the crimping jaws by a pawl lock known in design and application. Once introduced, an operating stroke for the respective crimping is carried out in full in all cases.

In crimping tools with crimping jaws opening in a scissor-like manner, the compensation of crimping stroke differences has been effected in that only one of the mouth jaws is rigidly articulated. The other mouth jaw is articulated via an elastic zone, also in the form of a separate elastic element, to the associated handle with the interposition of the actuating member; e.g. a toggle lever mechanism (DE-PS 3109 289).

In contrast, in crimping tools designed according to the generic type, the compensation of the crimping stroke difference can be designed in such a manner that an elastically acting support, which is expediently formed by a separate elastic element, is arranged on at least one of the force transmitting elements (EP-PS O158 611). In this case, a toggle lever belonging to the force transmitting system is constructed at its outer hinged point so as to be displaceable against the action of a tension spring and is thereby able to adapt to a limited degree, together with a pawl lock, to the profile which is to be crimped. This type of indirect elastic support of the pivot lever accommodating the crimping jaws must be regarded as disadvantageous in many respects, since crimping errors which can occur in the degree of completion of the crimping can go unnoticed and therefore cannot be ruled out.

Crimping tools according to the generic features for crimping lead end sleeves onto electrical conductors have crimping jaws which are arranged in the tool head section, are enclosed by a pivot lever formed by the tool limb and can be displaced centrally relative to one another by the pivoting movement of the pivot lever. Thereby they can be brought into and out of the crimping position (U.S. Pat. No. 3,203, 078).

In this type of crimping tool, the pivot lever is brought into a drive connection with the crimping jaws via a splined shaft profile, and the pivot lever is accommodated and displaceable in a centring fashion on the outer peripheral surfaces of the crimping jaws. The crimping jaws are pivotably mounted and axially fixed to the lower base plate of one crimping tool part on through bearing pins.

Because of the type and shape of the die and also the design of the structural operating elements, the crimping tool proposed here is unsuitable for crimping lead end sleeves. The latter require crimping which is complete on all sides, is as uniform as possible over the entire cross section and has precise dimensions, which cannot be achieved using crimping tools of this type.

Further known tool designs for crimping electrical conductors are illustrated and described in U.S. Pat. No. 5,261, 263, U.S. Pat. No. 3,199,335, GB-PS 886,259 and GB-PS 1,324,253. These tool designs are also unsuitable for meeting the current demands of connecting or crimping technology in power electronics in terms of providing crimping which has shape precision, is non-destructive and secure. Furthermore, they are neither suitable for repeated crimping, nor are they simple and easy to handle. Whilst the structural operating features have been complicated in design and require relatively high technological outlay, it is also precisely these elements which impair the operating properties of these crimping tools as regards high operating position precision and a low degree of operational disturbance.

It is also true that multi-surface crimping tools of this type require very precise movement of the crimping jaws, particularly in the case of small and miniature crimping dimensions, for instance in the range below 1 mm², and therefore require a similarly precise drive or force transmission system and springing system between the displaced crimping tool parts.

To date, known designs of this type of crimping tool cannot fulfil the expectations in practice, or can only fulfil them to an unsatisfactory degree. It is these circumstances which have given rise to the purpose and object of the present invention.

SUMMARY OF THE INVENTION

The purpose of the invention is the further technological and operational perfection of the type of tool in question.

This gives rise to the object of the invention, which, in a crimping tool of this type, whilst essentially retaining a toggle lever for the drive of the pivot lever, is to improve and refine the kinematic system of the crimping jaws, to simplify and perfect the force-stroke compensation provided for application between the force transmission elements, and to construct the crimping jaws with a more effective die profile.

This object is attained according to the invention by a crimping tool for crimping lead end sleeves, contact sockets or lugs onto electrical conductors, having crimping jaws which are arranged in the tool head section, perform the crimping, are pivotally mounted and axially fixed in the tool head section on through bearing pins, jointly form a crimping aperture of adjustable cross section, are enclosed by a pivot lever which drives them, on their outer peripheral surfaces receive the pivot lever in a centring and drive-transmitting manner in a spline shaft profile, and can be brought into and out of their crimping position by the pivoting drive movement of the pivot lever effected by means of a toggle lever mechanism driven by handles.

The tool also has a force-stroke compensation, which is automatically effected, e.g. by springs, and is arranged

between the handles and the crimping jaws, being created in the crimping tool between the parts of the force transmission system in order to compensate for crimping profiles of different dimensions and the resulting variable crimping stroke during the crimping process, the crimping jaws being formed in the region of their crimping profile by a die profile surface and a sliding surface in each case, and the die surfaces of all the crimping jaws forming a die profile of closed shape (e.g. a square or hexagon) in all crimping positions within their adjustable crimping range, to which purpose the rotational or pivot axis of the crimping jaws is defined by the median perpendicular formed by the straight line extending from the respective profile corner towards the profile center, together with the pitch circle chosen for the bearing pins, and the sliding surface of each crimping jaw being in planar contact with the die surface of the adjacent crimping jaw, extending the plane of the adjacent die surface, and the fixed handle being constructed as a compensating spring for force-stroke compensation between parts of the force transmission system by means of a reduction in its cross section in the form of a waist in its middle section, together with an elastic lever integrated and fixed in the handle and mechanically linked with one lever arm of the toggle joint mechanism.

In accordance with another feature of the present invention the crimping jaws have a profile on their die surface such that the crimped surfaces of the lead end sleeves are formed with a crimped profile that may be either circumferential or offset, the profile being formed by a basic triangular shape, whose profile points are rounded.

In accordance with still a further feature of present invention the elastic lever is constructed as part of the handle and has both a positive and friction connection with said handle at its rear end section by means of bolts and splines.

BRIEF DESCRIPTION OF THE DRAWINGS

The invention will be illustrated and explained in further detail in the following by way of an embodiment with the aid of the associated drawings, in which:

FIG. 1 is an overall view of the crimping tool with all fundamental operating parts;

FIG. 2 is a detailed view for the construction of the spring elements shown as a partial section through the right-hand crimping tool handle;

FIGS. 3 and 4 show the geometric relationships for constructing and arranging the crimping jaws and the kinematics thereof; in the case of hexagonal and square crimping;

FIG. 5 shows a crimping jaw with a view of its die surface construction;

FIGS. 6 and 7 are schematic illustration of the possible types of crimping on lead end sleeves;

FIG. 8 is a partial cross section through the die profile of a crimping jaw.

DESCRIPTION OF PREFERRED EMBODIMENTS

The crimping tool 1 is constructed in known manner from two base plates 2, 3, which at one end form a head section 4 and at the other end handles 5 and 6. Formed in the right-hand handle 6 approximately in its middle section is an outer elastic zone 8, which is expediently created by a waist 7. It is capable of springing in and out relative to the adjacent head section 4 and the handle 5 when a corresponding force is applied, as will be described below.

Also arranged approximately in the same section is an inner or inwardly-lying spring 9. It is constructed as an elastic lever, is displaceably held at one of its ends and has a common hinge point 10 or clamping region 10 with the outer elastic zone 8 of the right-hand handle 6.

At its other freely projecting end, which is constructed as an open bearing seat 11, the spring 9 is connected in a positive-locking manner with a toggle lever 12. The latter is mounted in the left-hand handle 5 and, as shown in FIG. 1, belongs in a manner known in principle to a toggle lever mechanism, comprising the levers 12 and 13 and the handle 5, and forms the operative element of this crimping tool drive. The other of the two toggle levers, in this case bearing the reference numeral 13, is constructed between the common bearing point 14 and the bearing point 15, the latter belonging to the pivot lever 16 which is to be driven.

The pivot lever 16 is arranged between the two base plates 2 and 3 of the crimping tool body 1. It is connected for the drive action, as already mentioned, with the toggle lever mechanism at the bearing point 15 by means of a bracket 17 provided on the pivot lever 16. According to the invention, the pivot lever 16 is resiliently supported via the lever traction of the toggle lever against the elastic elements 8 and 9.

On its output side, the pivot lever 16 is connected to the crimping jaws 18 of the crimping tool. This connection is based on positive locking produced by a splined shaft profile 19. This detail is clearly shown in FIG. 1 and in particular in FIGS. 3 and 4. In this respect, it should be emphasized that whilst this arrangement of the pivot lever 16 is guided, it is otherwise freely displaceable.

As already proposed, the crimping jaws 18 are connected to the lower base plate 3 and pivotably mounted thereon with the aid of a through bearing pin 21.

In this respect, the spatial arrangement, the mounting and the working profile of the crimping jaws 18 fulfil the following geometric requirements as part of the solution according to the invention:

The profile which is to be formed by the pivotable crimping jaws 18, as shown in the plane of the drawing, is formed in each case by the die surfaces 22, 23 lying adjacent one another. This is shown in FIGS. 3 and 4. The die surfaces 22 and 23 can be designed for polygonal crimping, preferably for square or hexagonal crimping. The geometric design and mechanical adjustment is effected in an entirely rosette-like manner, as shown in FIG. 1.

The pivot point 24 of the crimping jaws 18 lies in each case on the median perpendicular 25 which is formed between one of the corner points of the maximum crimping profile and the profile center point 26 thereof. In respect of the arrangement and mounting of the crimping jaws 18, it should also be noted that the distance of the bearing pins 21 from the profile center point in each case determines the degree of the transmission which is effective in this case and also the size of the crimping area.

In the embodiment of the present invention, the transmission ratio is preferably 1:1.

The two elastic elements 8 and 9, which according to the invention represent a new, simple and advantageous technical solution to the problem of compensating the different crimping areas which arises in crimping tools of this type are securely joined together in the rear end section of the right-hand handle 6. The joining is performed by transversely penetrating bolts 27 and longitudinally imprinted splines 28 and act in this region as a compact unit. This is important for the function and property of the springs 8 and 9 beyond their common hinge point 10.

Explore Litigation Insights

Docket Alarm provides insights to develop a more informed litigation strategy and the peace of mind of knowing you're on top of things.

Real-Time Litigation Alerts



Keep your litigation team up-to-date with **real-time alerts** and advanced team management tools built for the enterprise, all while greatly reducing PACER spend.

Our comprehensive service means we can handle Federal, State, and Administrative courts across the country.

Advanced Docket Research



With over 230 million records, Docket Alarm's cloud-native docket research platform finds what other services can't. Coverage includes Federal, State, plus PTAB, TTAB, ITC and NLRB decisions, all in one place.

Identify arguments that have been successful in the past with full text, pinpoint searching. Link to case law cited within any court document via Fastcase.

Analytics At Your Fingertips



Learn what happened the last time a particular judge, opposing counsel or company faced cases similar to yours.

Advanced out-of-the-box PTAB and TTAB analytics are always at your fingertips.

API

Docket Alarm offers a powerful API (application programming interface) to developers that want to integrate case filings into their apps.

LAW FIRMS

Build custom dashboards for your attorneys and clients with live data direct from the court.

Automate many repetitive legal tasks like conflict checks, document management, and marketing.

FINANCIAL INSTITUTIONS

Litigation and bankruptcy checks for companies and debtors.

E-DISCOVERY AND LEGAL VENDORS

Sync your system to PACER to automate legal marketing.