



US 20130310929A1

(19) **United States**

(12) **Patent Application Publication**

**Dove et al.**

(10) **Pub. No.: US 2013/0310929 A1**

(43) **Pub. Date: Nov. 21, 2013**

(54) **METHODS OF CONDITIONING SHEET BIOPROSTHETIC TISSUE**

(60) Provisional application No. 61/316,801, filed on Mar. 23, 2010, provisional application No. 61/381,858, filed on Sep. 10, 2010.

(71) Applicant: **Edwards Lifesciences Corporation**, Irvine, CA (US)

**Publication Classification**

(72) Inventors: **Jeffrey S. Dove**, Santa Ana, CA (US); **Bin Tian**, Irvine, CA (US); **Ralph Schneider**, Trabuco Canyon, CA (US); **Jeffrey S. Cohen**, Irvine, CA (US); **Ivan Jankovic**, Costa Mesa, CA (US); **John F. Migliazza**, Belmont Shore, CA (US); **Gregory A. Wright**, Orange, CA (US); **James Young**, Ladera Ranch, CA (US); **Louis A. Campbell**, Santa Ana, CA (US)

(51) **Int. Cl.**  
*A61F 2/24* (2006.01)

(52) **U.S. Cl.**  
CPC ..... *A61F 2/2415* (2013.01)  
USPC ..... **623/2.13**; 264/299; 264/138

(73) Assignee: **EDWARDS LIFESCIENCES CORPORATION**, Irvine, CA (US)

(57) **ABSTRACT**

Methods for the conditioning of bioprosthetic material employ bovine pericardial membrane. A laser directed at the fibrous surface of the membrane and moved relative thereto reduces the thickness of the membrane to a specific uniform thickness and smoothes the surface. The wavelength, power and pulse rate of the laser are selected which will smooth the fibrous surface as well as ablate the surface to the appropriate thickness. Alternatively, a dermatome is used to remove a layer of material from the fibrous surface of the membrane. Thinning may also employ compression. Stepwise compression with cross-linking to stabilize the membrane is used to avoid damaging the membrane through inelastic compression. Rather, the membrane is bound in the elastic compressed state through addition cross-linking. The foregoing several thinning techniques may be employed together to achieve strong thin membranes.

(21) Appl. No.: **13/950,154**

(22) Filed: **Jul. 24, 2013**

**Related U.S. Application Data**

(63) Continuation of application No. 13/069,827, filed on Mar. 23, 2011.

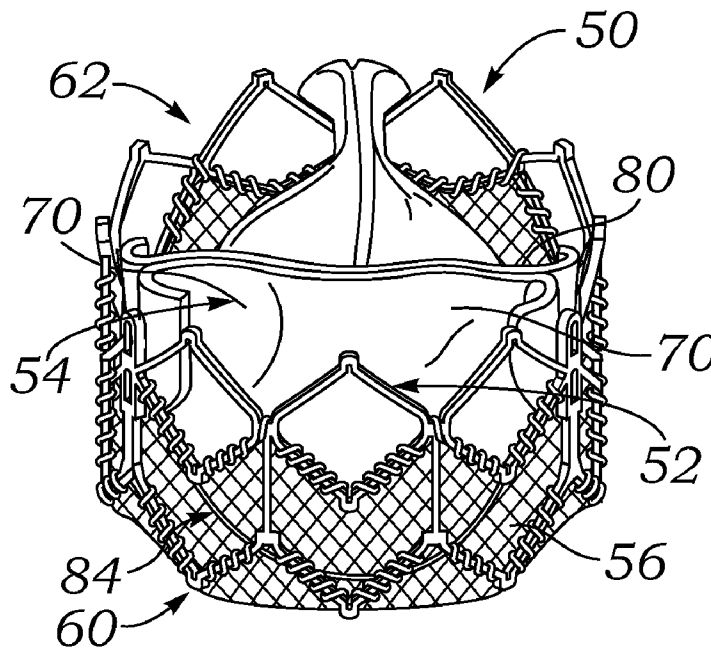

**Edwards Lifesciences v. Boston Scientific**  
**U.S. Patent No. 6,915,560**  
**IPR2017-00444 EX. 2035**

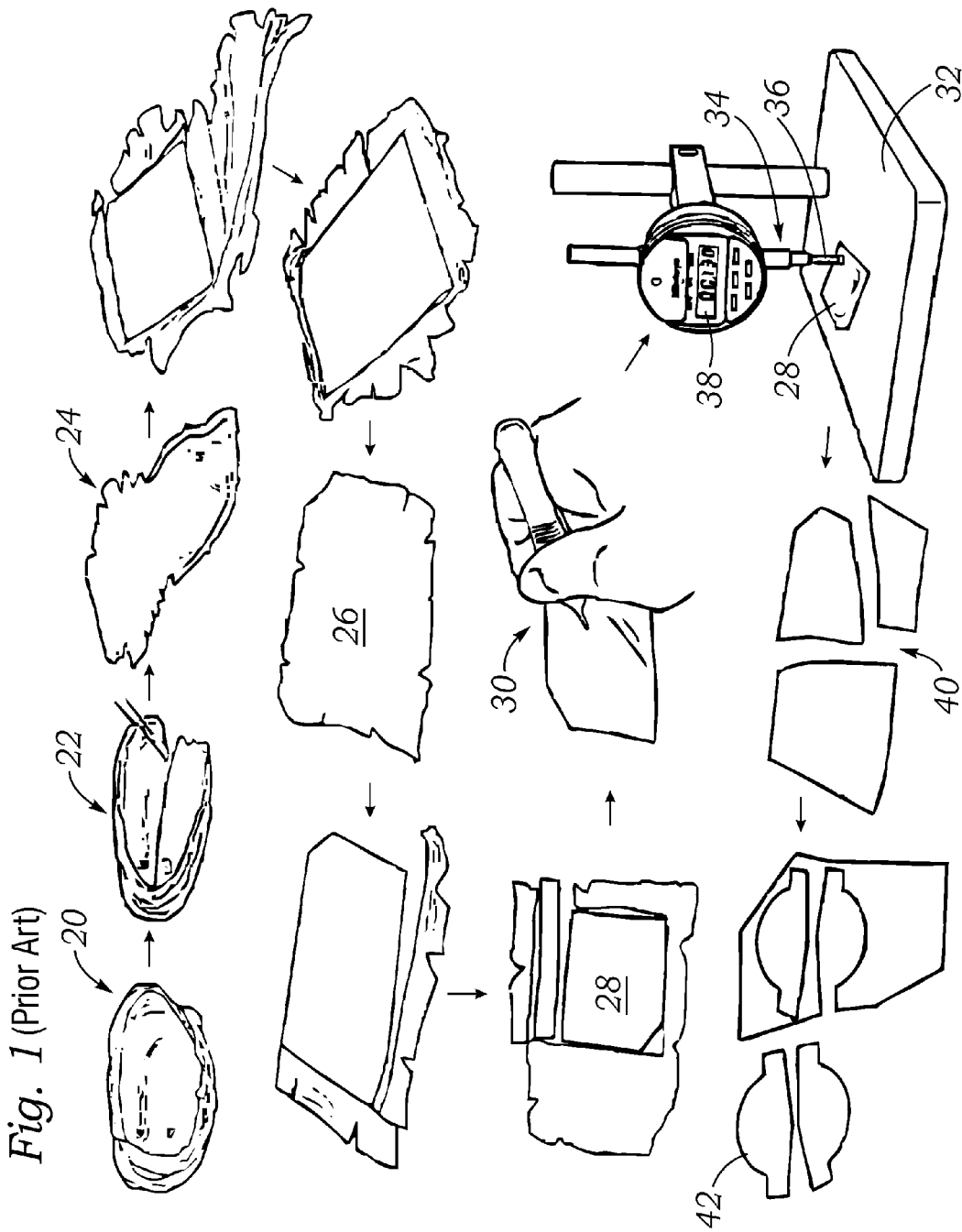

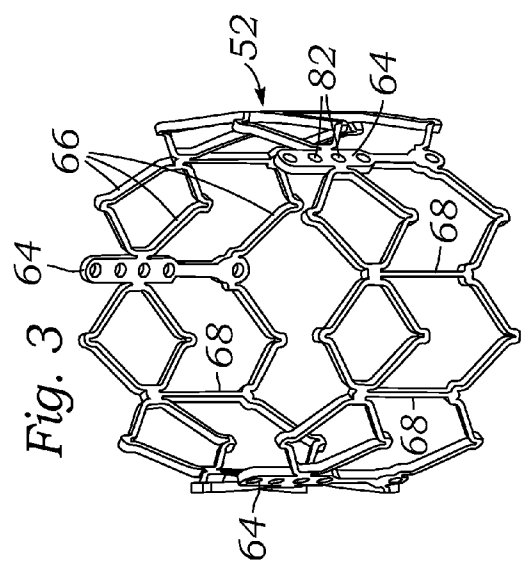
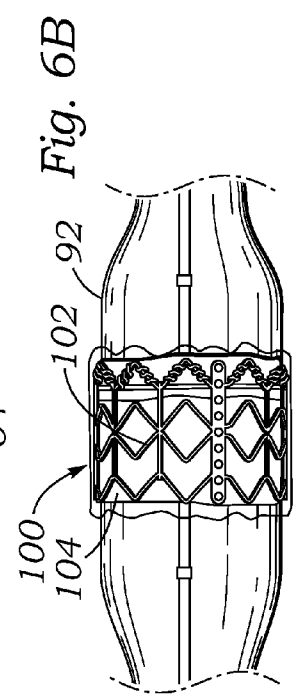
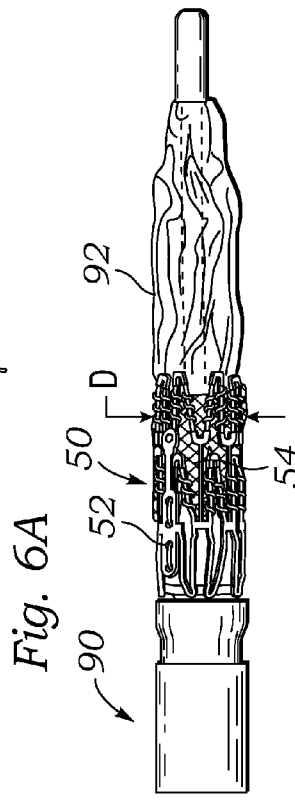
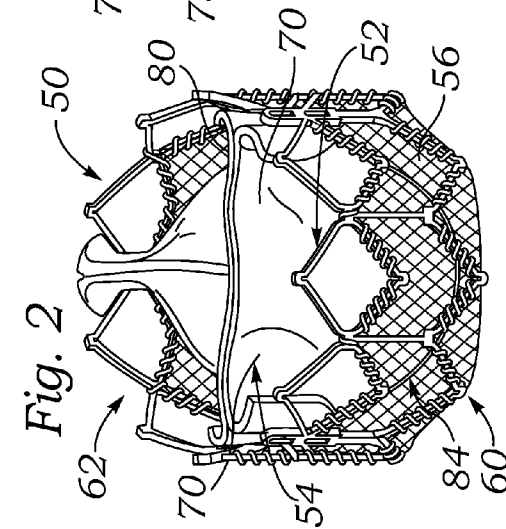
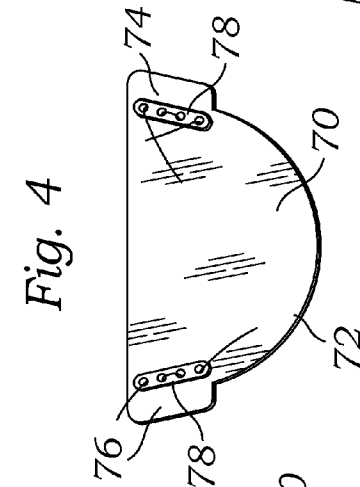
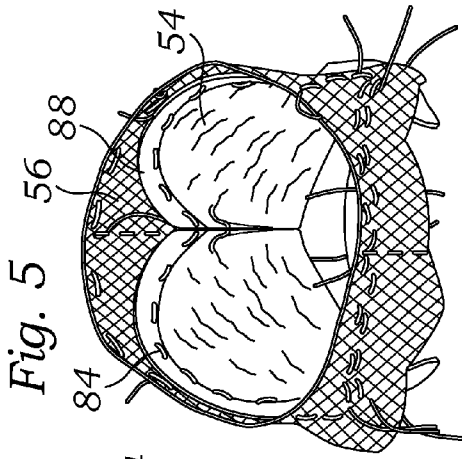

Fig. 7

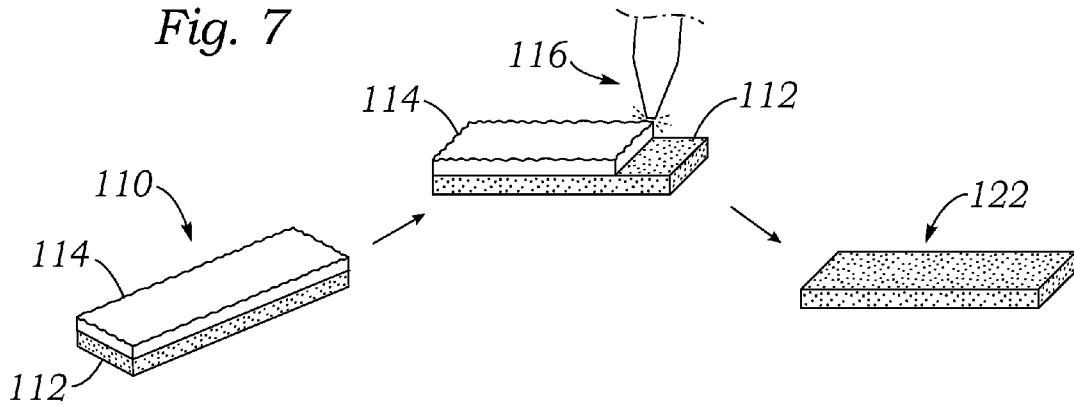

Fig. 8

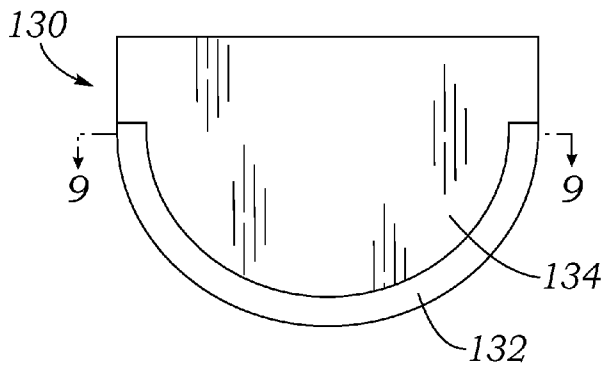
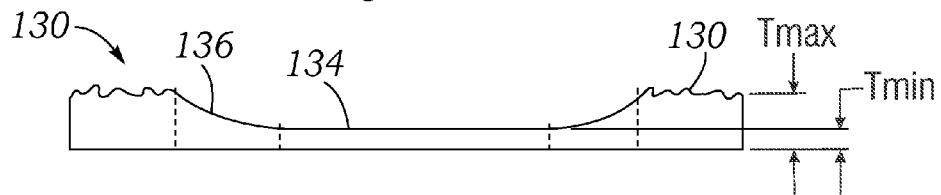
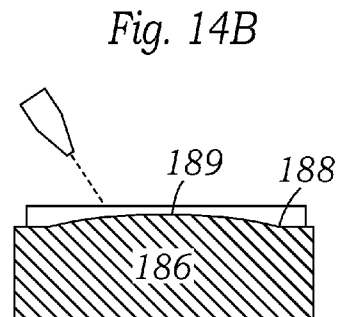
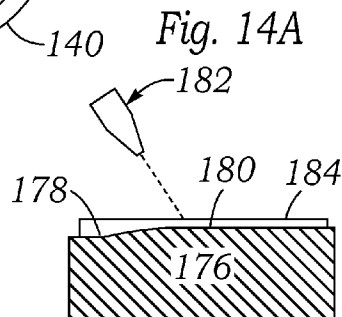
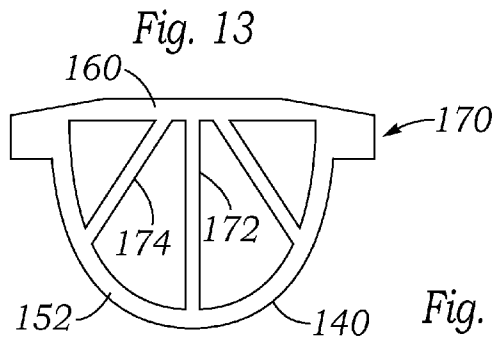
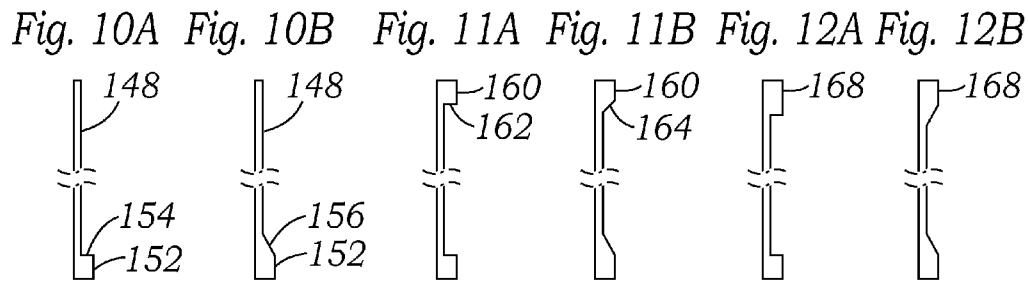
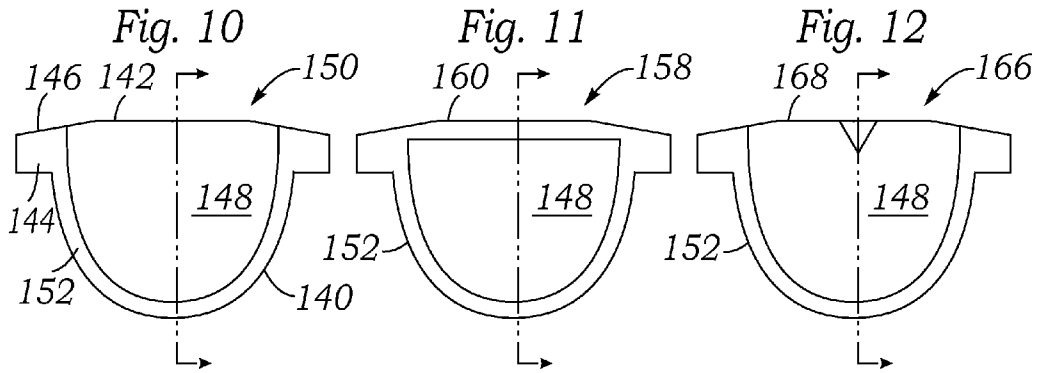

Fig. 9





# Explore Litigation Insights

Docket Alarm provides insights to develop a more informed litigation strategy and the peace of mind of knowing you're on top of things.

## Real-Time Litigation Alerts



Keep your litigation team up-to-date with **real-time alerts** and advanced team management tools built for the enterprise, all while greatly reducing PACER spend.

Our comprehensive service means we can handle Federal, State, and Administrative courts across the country.

## Advanced Docket Research



With over 230 million records, Docket Alarm's cloud-native docket research platform finds what other services can't. Coverage includes Federal, State, plus PTAB, TTAB, ITC and NLRB decisions, all in one place.

Identify arguments that have been successful in the past with full text, pinpoint searching. Link to case law cited within any court document via Fastcase.

## Analytics At Your Fingertips



Learn what happened the last time a particular judge, opposing counsel or company faced cases similar to yours.

Advanced out-of-the-box PTAB and TTAB analytics are always at your fingertips.

## API

Docket Alarm offers a powerful API (application programming interface) to developers that want to integrate case filings into their apps.

## LAW FIRMS

Build custom dashboards for your attorneys and clients with live data direct from the court.

Automate many repetitive legal tasks like conflict checks, document management, and marketing.

## FINANCIAL INSTITUTIONS

Litigation and bankruptcy checks for companies and debtors.

## E-DISCOVERY AND LEGAL VENDORS

Sync your system to PACER to automate legal marketing.