



US005080215A

United States Patent [19]

Förster et al.

[11] Patent Number: **5,080,215**

[45] Date of Patent: **Jan. 14, 1992**

- [54] **TORSION VIBRATION DAMPER**
- [75] Inventors: **Andreas Förster, Schweinfurt;**
Bernhard Schierling, Kürnach, both
of Fed. Rep. of Germany
- [73] Assignee: **Fichtel & Sachs AG, Schweinfurt,**
Fed. Rep. of Germany
- [21] Appl. No.: **599,669**
- [22] Filed: **Oct. 18, 1990**

- [30] **Foreign Application Priority Data**
Oct. 19, 1989 [DE] Fed. Rep. of Germany 3934798
- [51] Int. Cl.⁵ **F16D 47/06**
- [52] U.S. Cl. **192/106.2; 267/167**
- [58] Field of Search 192/106.2; 464/64, 68;
267/166, 167, 286

[56] **References Cited**

U.S. PATENT DOCUMENTS

2,587,810	3/1952	Beyer	267/167
2,797,937	7/1957	Frishof	267/167
3,468,527	9/1969	Mather	267/167
4,347,717	9/1982	Lamarche	192/106.2
4,422,535	12/1983	Ling	192/106.2
4,451,244	5/1984	Lamarche	192/106.2
4,637,500	1/1987	Göbel	192/106.2
4,716,998	1/1988	Tsukamoto et al.	192/106.2
4,857,032	8/1989	Aiki et al.	192/106.2

4,987,980 1/1991 Fujimoto 192/106.2

FOREIGN PATENT DOCUMENTS

0136825	4/1985	European Pat. Off. .	
3723015	1/1989	Fed. Rep. of Germany .	
3831009	3/1989	Fed. Rep. of Germany ...	192/106.2
2620503	3/1989	France	192/106.2
2193290	2/1988	United Kingdom .	
2193789	2/1988	United Kingdom .	
2194020	2/1988	United Kingdom .	
2194021	2/1988	United Kingdom .	
2206950	1/1989	United Kingdom .	

Primary Examiner—Leslie A. Braun
Assistant Examiner—Nicholas Whitelaw
Attorney, Agent, or Firm—Toren, McGeedy & Associates

[57] **ABSTRACT**

The invention relates to torsion vibration dampers in the power transmission path of a motor vehicle with an internal combustion engine, the coil thrust springs used being particularly in the case of a considerable length in proportion to their diameter, already precurved prior to fitment into their final position. This facilitates fitment and makes it possible to influence the development of friction force as the rotary speed increases.

20 Claims, 9 Drawing Sheets

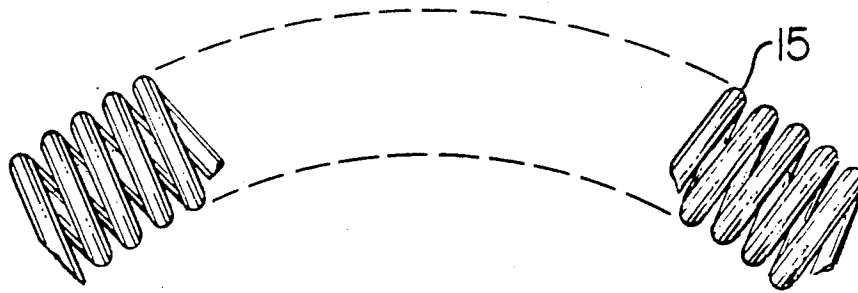

Fig. 1

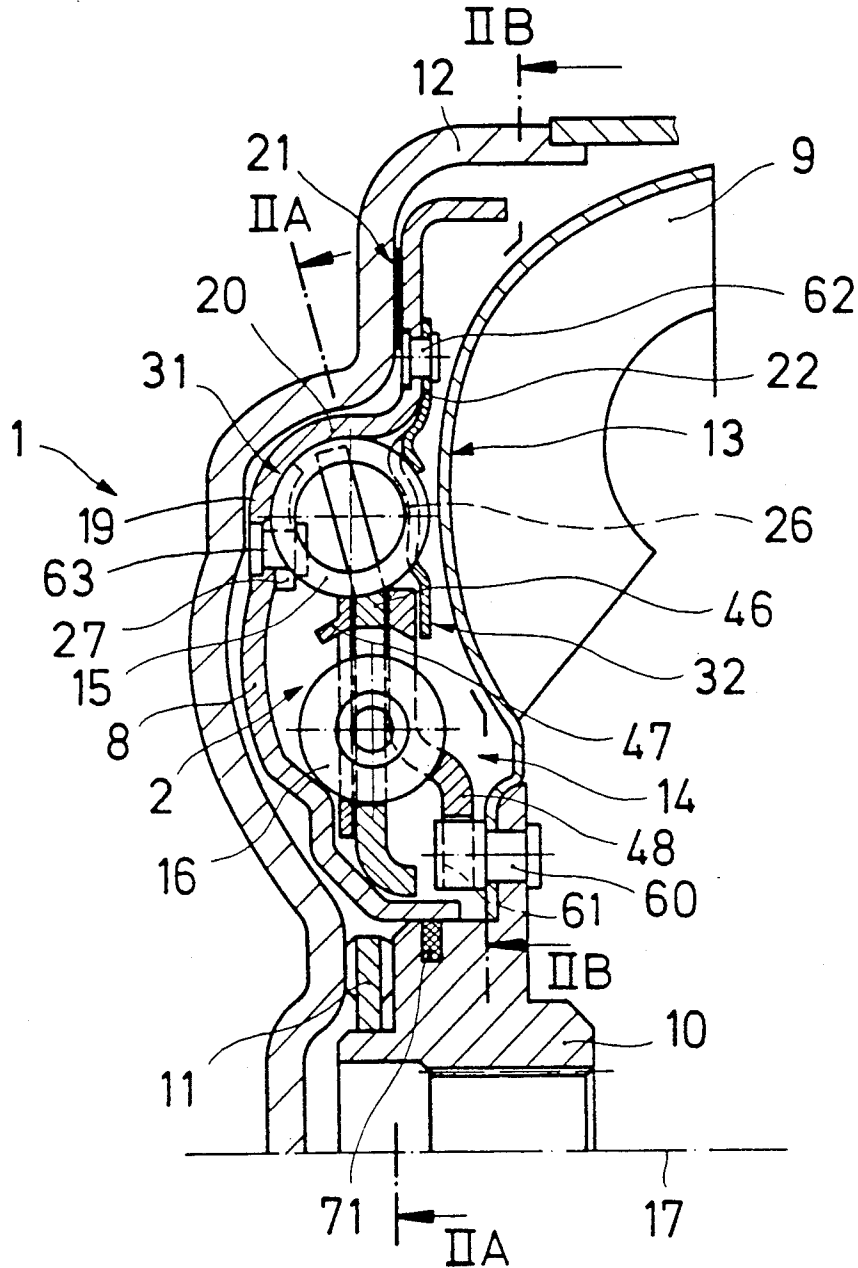

Fig. 2a

Fig. 2b

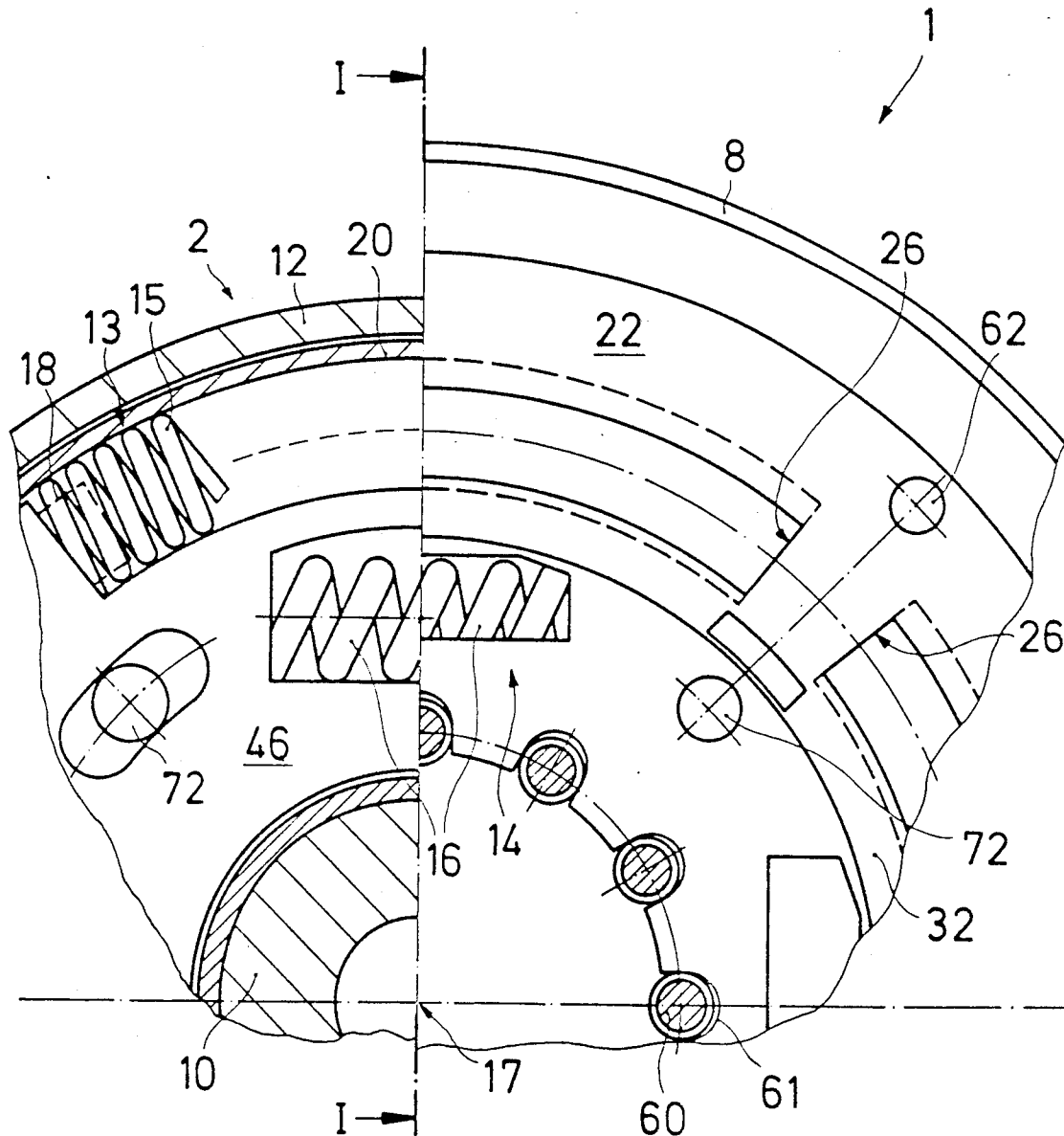

Fig. 3

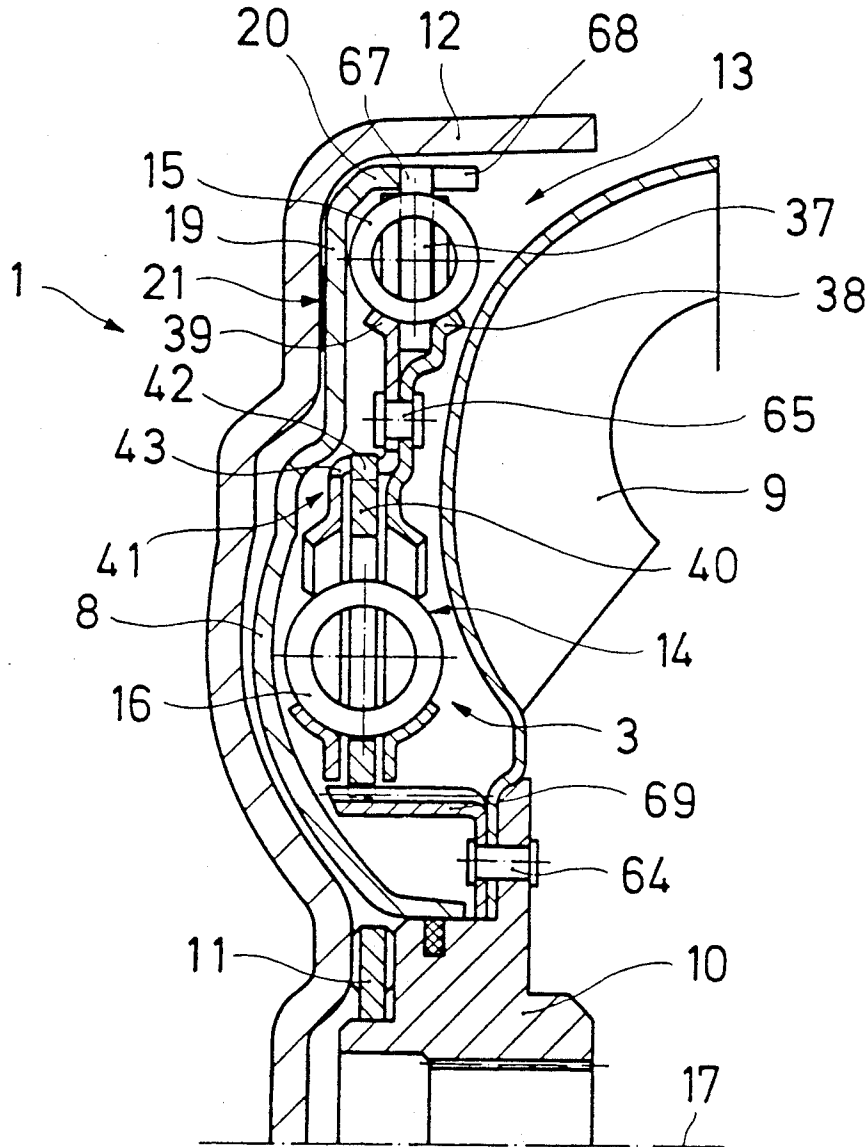
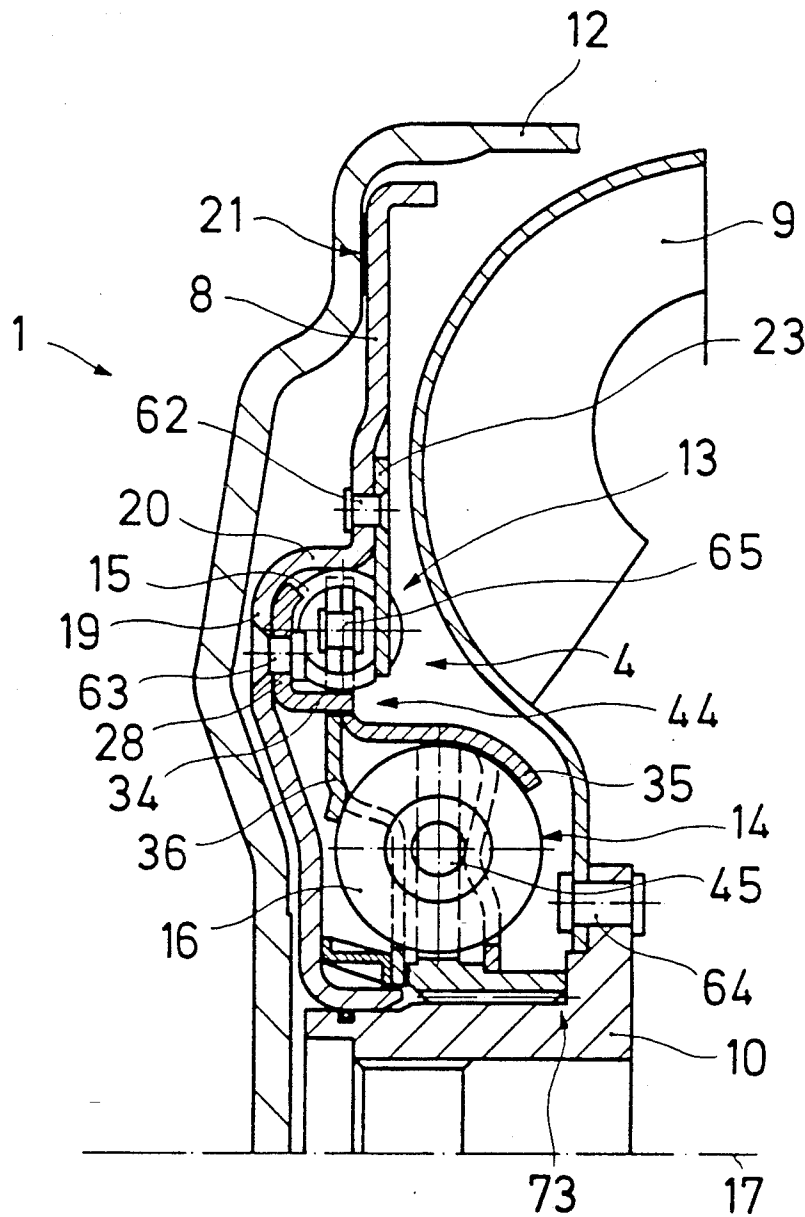

Fig. 4



Explore Litigation Insights

Docket Alarm provides insights to develop a more informed litigation strategy and the peace of mind of knowing you're on top of things.

Real-Time Litigation Alerts



Keep your litigation team up-to-date with **real-time alerts** and advanced team management tools built for the enterprise, all while greatly reducing PACER spend.

Our comprehensive service means we can handle Federal, State, and Administrative courts across the country.

Advanced Docket Research



With over 230 million records, Docket Alarm's cloud-native docket research platform finds what other services can't. Coverage includes Federal, State, plus PTAB, TTAB, ITC and NLRB decisions, all in one place.

Identify arguments that have been successful in the past with full text, pinpoint searching. Link to case law cited within any court document via Fastcase.

Analytics At Your Fingertips



Learn what happened the last time a particular judge, opposing counsel or company faced cases similar to yours.

Advanced out-of-the-box PTAB and TTAB analytics are always at your fingertips.

API

Docket Alarm offers a powerful API (application programming interface) to developers that want to integrate case filings into their apps.

LAW FIRMS

Build custom dashboards for your attorneys and clients with live data direct from the court.

Automate many repetitive legal tasks like conflict checks, document management, and marketing.

FINANCIAL INSTITUTIONS

Litigation and bankruptcy checks for companies and debtors.

E-DISCOVERY AND LEGAL VENDORS

Sync your system to PACER to automate legal marketing.