



US007073646B2

(12) **United States Patent**
Sasse et al.

(10) **Patent No.:** **US 7,073,646 B2**
(45) **Date of Patent:** **Jul. 11, 2006**

(54) **TORSIONAL VIBRATION DAMPER**

(56) **References Cited**

(75) Inventors: **Christoph Sasse**, Schweinfurt (DE);
Jörg Sudau, Niederwerrn (DE); **Ralf Rönnebeck**, Schonungen (DE); **Jürgen Ackermann**, Schweinfurt (DE); **Peter Frey**, Gerolzhofen (DE); **Erwin Wack**, Niederwerrn (DE); **Frank Zerner**, Schweinfurt (DE)

U.S. PATENT DOCUMENTS

4,523,916 A	6/1985	Kizler et al.	
4,987,980 A *	1/1991	Fujimoto	192/3.28
5,080,215 A	1/1992	Förster et al.	
5,575,363 A	11/1996	Dehrmann et al.	
5,713,442 A *	2/1998	Murata et al.	192/3.29
6,571,929 B1 *	6/2003	Tomiyama et al.	192/213.1

(73) Assignee: **ZF Sachs AG**, Schweinfurt (DE)

FOREIGN PATENT DOCUMENTS

DE	43 33 562 A1	4/1994
DE	195 14 411	11/1995
DE	199 20 542 A1	11/1999

(*) Notice: Subject to any disclaimer, the term of this patent is extended or adjusted under 35 U.S.C. 154(b) by 63 days.

* cited by examiner

Primary Examiner—Saul Rodriguez

(74) *Attorney, Agent, or Firm*—Cohen, Pontani, Lieberman & Pavane

(21) Appl. No.: **10/817,121**

(22) Filed: **Apr. 2, 2004**

(65) **Prior Publication Data**

US 2004/0226794 A1 Nov. 18, 2004

(30) **Foreign Application Priority Data**

Apr. 5, 2003	(DE)	103 15 567
Oct. 28, 2003	(DE)	103 50 297
Dec. 16, 2003	(DE)	103 58 901

(57) **ABSTRACT**

A torsional vibration damper on the bridging clutch of a hydrodynamic clutch arrangement has a first connecting device, which can be brought into working connection with the clutch housing and with a drive-side transmission element. The drive-side transmission element is connected via first energy-storage devices to an intermediate transmission element. The torsional vibration damper also has a second connecting device for establishing a working connection via second energy-storage devices between the intermediate transmission element and a takeoff-side transmission element, which is connected to a takeoff-side component of the hydrodynamic clutch arrangement. The intermediate transmission element accepts a mass element, located operatively between the two connecting devices.

(51) **Int. Cl.**
F16D 47/02 (2006.01)

(52) **U.S. Cl.** **192/3.29; 192/213.1**

(58) **Field of Classification Search** **192/2.29, 192/213.1**

See application file for complete search history.

36 Claims, 10 Drawing Sheets

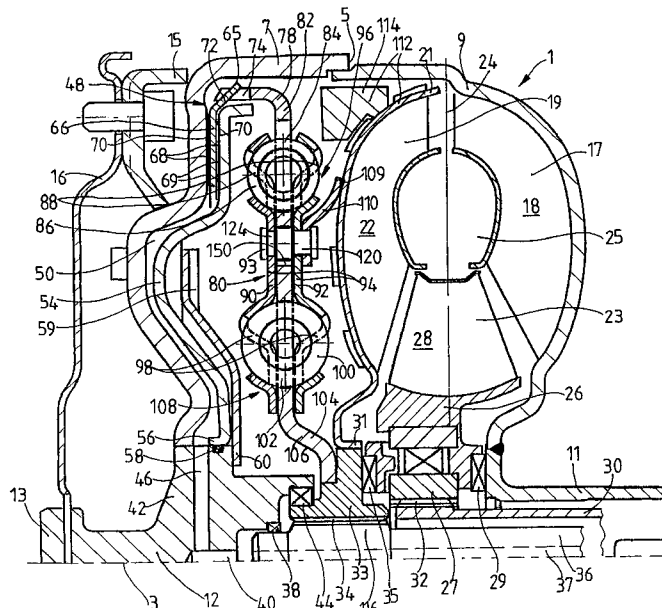
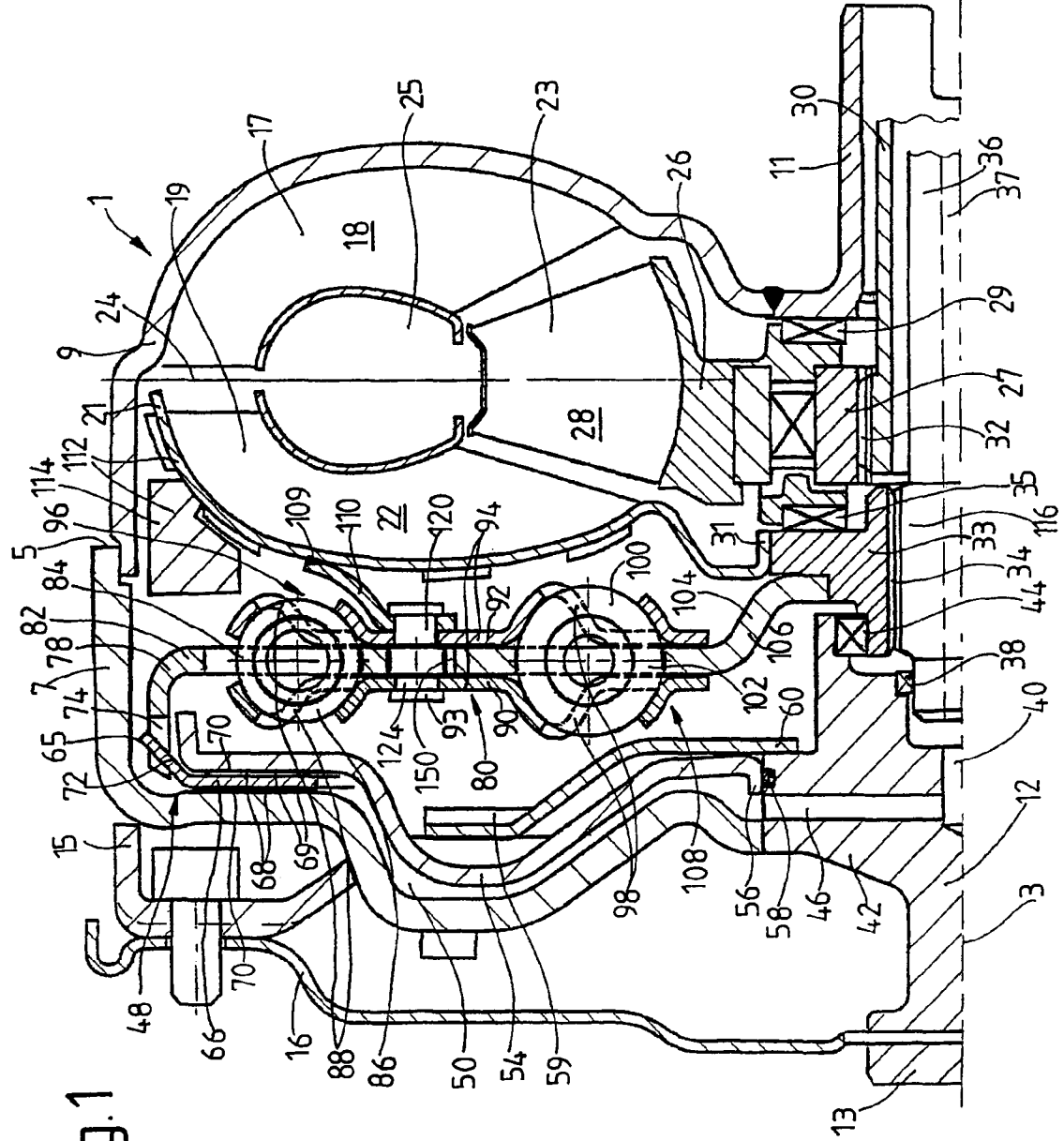

Fig.1



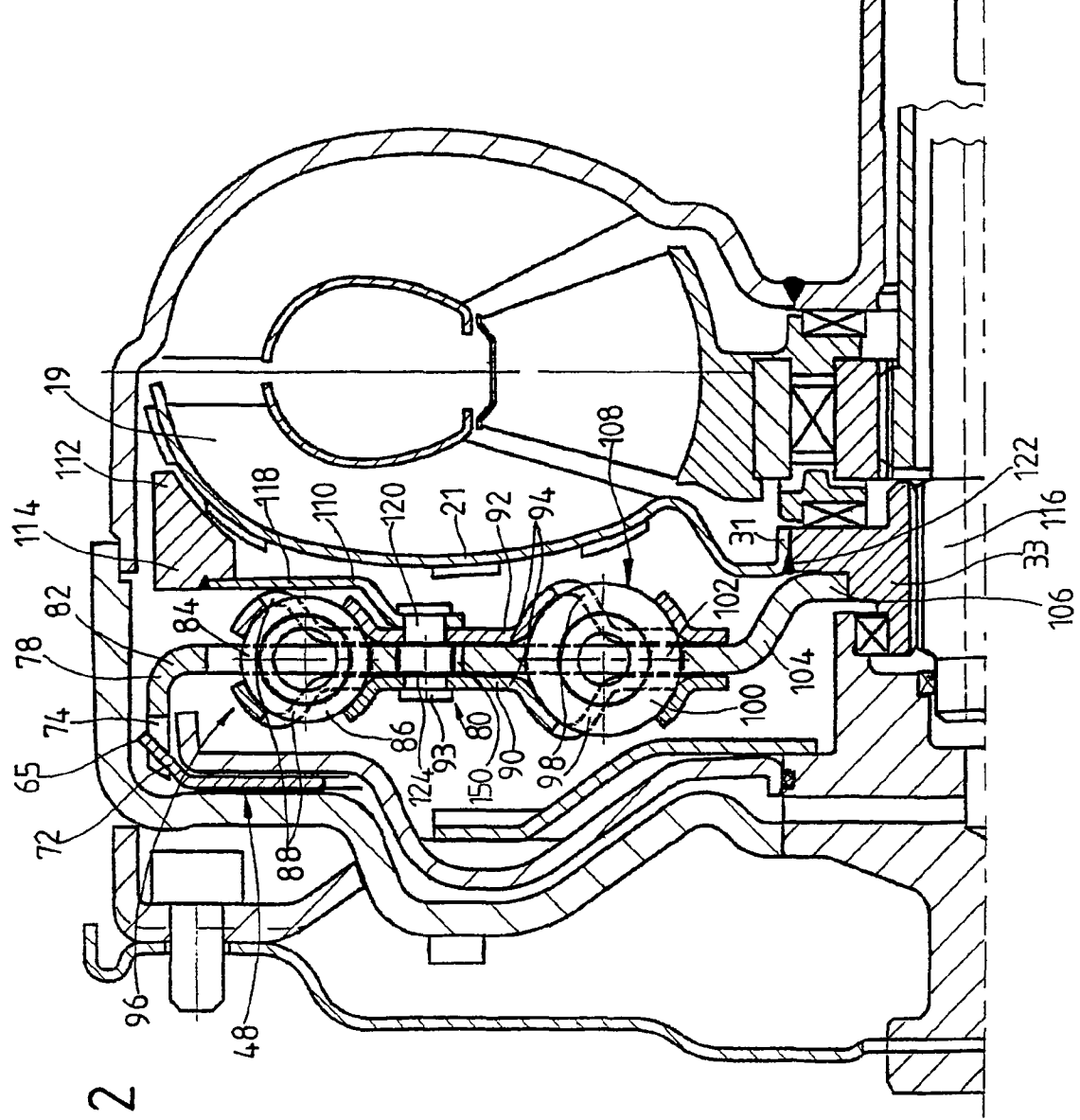

Fig. 2

Fig. 3

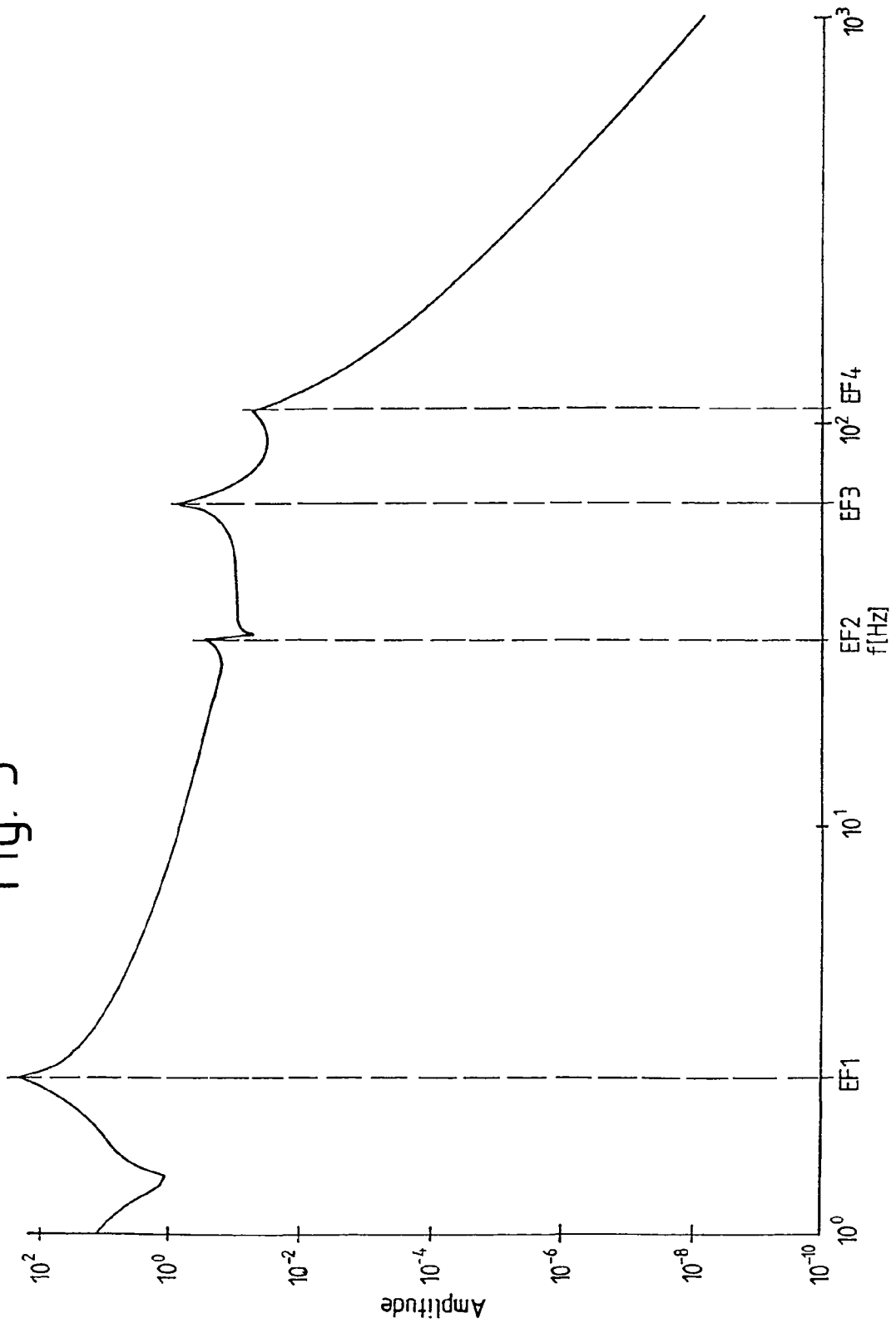
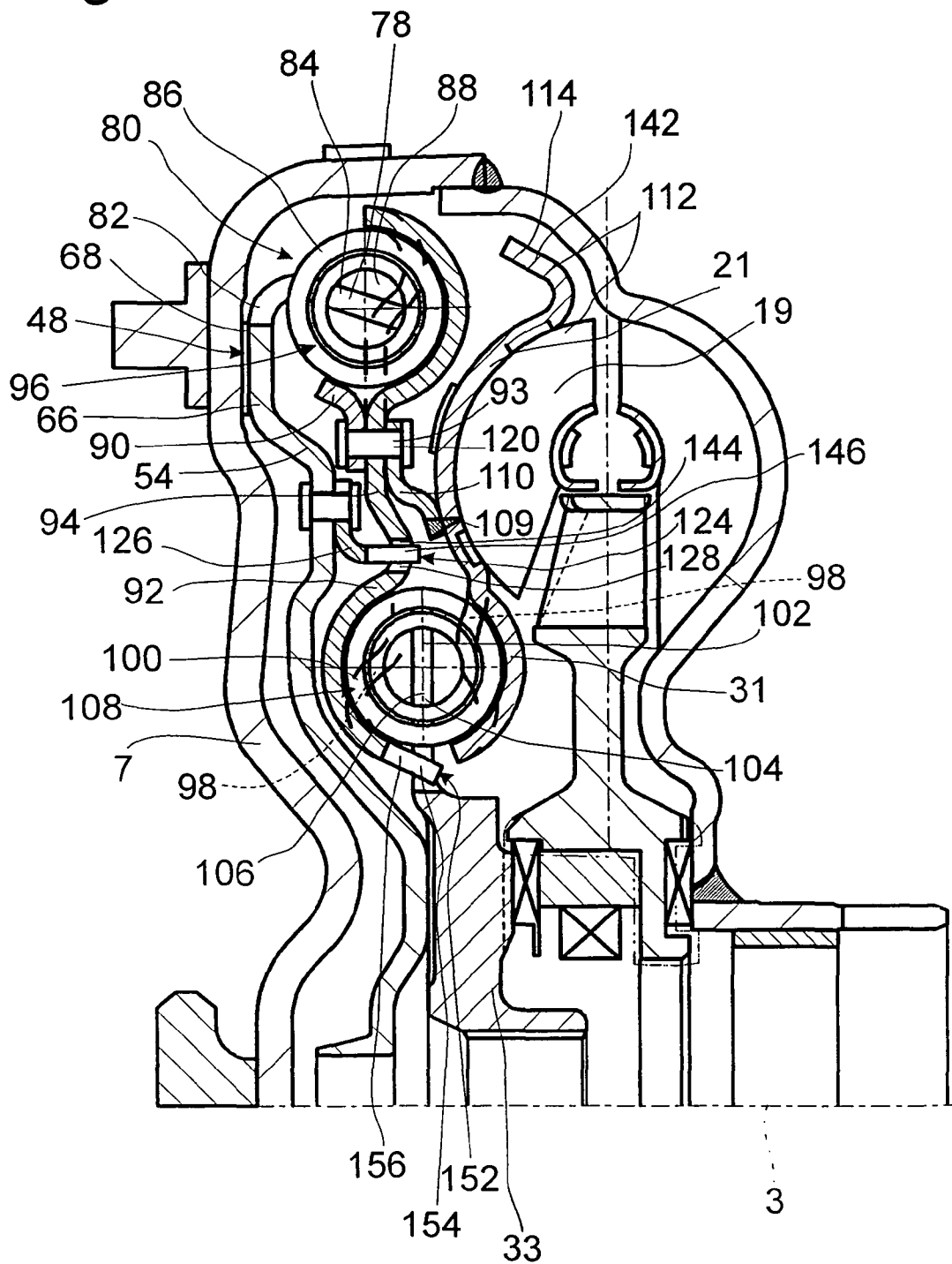

Fig. 4



Explore Litigation Insights

Docket Alarm provides insights to develop a more informed litigation strategy and the peace of mind of knowing you're on top of things.

Real-Time Litigation Alerts



Keep your litigation team up-to-date with **real-time alerts** and advanced team management tools built for the enterprise, all while greatly reducing PACER spend.

Our comprehensive service means we can handle Federal, State, and Administrative courts across the country.

Advanced Docket Research



With over 230 million records, Docket Alarm's cloud-native docket research platform finds what other services can't. Coverage includes Federal, State, plus PTAB, TTAB, ITC and NLRB decisions, all in one place.

Identify arguments that have been successful in the past with full text, pinpoint searching. Link to case law cited within any court document via Fastcase.

Analytics At Your Fingertips



Learn what happened the last time a particular judge, opposing counsel or company faced cases similar to yours.

Advanced out-of-the-box PTAB and TTAB analytics are always at your fingertips.

API

Docket Alarm offers a powerful API (application programming interface) to developers that want to integrate case filings into their apps.

LAW FIRMS

Build custom dashboards for your attorneys and clients with live data direct from the court.

Automate many repetitive legal tasks like conflict checks, document management, and marketing.

FINANCIAL INSTITUTIONS

Litigation and bankruptcy checks for companies and debtors.

E-DISCOVERY AND LEGAL VENDORS

Sync your system to PACER to automate legal marketing.