



US006891803B1

(12) **United States Patent**  
**Chang et al.**

(10) **Patent No.:** **US 6,891,803 B1**  
(45) **Date of Patent:** **May 10, 2005**

- (54) **TELECOMMUNICATIONS TRANSMISSION TEST SET**
- (75) Inventors: **Paul Chang**, Fremont, CA (US); **Tom Dang**, San Jose, CA (US); **Chi Lin Wu**, San Jose, CA (US)
- (73) Assignee: **Sunrise Telecom, Inc.**, San Jose, CA (US)
- (\* ) Notice: Subject to any disclaimer, the term of this patent is extended or adjusted under 35 U.S.C. 154(b) by 0 days.
- (21) Appl. No.: **09/215,421**
- (22) Filed: **Dec. 18, 1998**
- (51) Int. Cl.<sup>7</sup> ..... **H04L 12/66**
- (52) U.S. Cl. .... **370/252; 370/248; 370/251; 370/247; 379/21; 379/10.01; 348/192; 714/715**
- (58) Field of Search ..... **379/21, 10.01, 379/22.04, 26.01, 26.02, 26.03; 370/245, 248, 249, 503, 252, 251, 250, 247; 324/512, 520, 521, 527, 528, 534, 535, 532; 348/192; 714/715**

- (56) **References Cited**
- U.S. PATENT DOCUMENTS**
- |             |        |                |
|-------------|--------|----------------|
| 3,956,601 A | 5/1976 | Harris et al.  |
| 4,402,055 A | 8/1983 | Lloyd et al.   |
| 4,536,703 A | 8/1985 | Jablway et al. |
| 4,651,298 A | 3/1987 | Currier, Jr.   |
| 4,837,811 A | 6/1989 | Butler et al.  |
| 4,843,620 A | 6/1989 | Hagedorn       |

(Continued)

- FOREIGN PATENT DOCUMENTS**
- |    |             |         |
|----|-------------|---------|
| DE | 3116079 A1  | 11/1982 |
| DE | 3743446 A1  | 7/1989  |
| DE | 3912230 C1  | 10/1990 |
| DE | 3933222 A1  | 4/1991  |
| DE | 4025417 A1  | 2/1992  |
| DE | 19509690 A1 | 9/1996  |

- EP 053 561 A2 6/1982
- EP 532 346 A2 3/1993

**OTHER PUBLICATIONS**

Disclosure Statement on behalf of Assignee Sunrise Telecom, Inc., with attached Declaration of Robert King, Vice President—North American Sales, Sunrise Telecom, Inc. Declaration of Paul Marshall, Chief Operating Officer, Vice President of Marketing and Acting Chief Financial Officer of Sunrise Telecom Incorporated, San Jose, CA, dated Mar. 3, 2004, pp. 1–3, with Exhibits A, B and C. Specialized Products Company, 1994 Spring Catalog, pp. 152, 168–169. Ironix Brochure, “T5000 EFP handheld Mobile Workstation,” undated. “Testing ATM Interoperability—HP Solution Note”, 5965–9334E Jun. 1997 Rev. A, 1997 ATM/Broadband Testing Seminar, Hewlett-Packard Company.

(Continued)

*Primary Examiner*—Wellington Chin  
*Assistant Examiner*—Chuong Ho  
(74) *Attorney, Agent, or Firm*—Townsend and Townsend and Crew LLP

(57) **ABSTRACT**

A test set includes at least one signal input port, a test circuitry, a processor, a user-input device, and a display. The test circuitry couples to and receives signals from the at least one signal input port. The test circuitry then generates test data corresponding to the received signals. The processor couples to and receives test data from the test circuitry and generates test results. The processor also couples to and receives commands from the user-input device. The processor further operatively couples to the graphical display that receives and displays the test results from the processor. In one embodiment, the test set is capable of performing line qualification and connectivity testing. A modem module can be used to facilitate connectivity testing. The modem module can be a plug-in module with a common interface to the test set. The modem module can also contain a fingerprint value that identifies the module type and the software revision number to the test set.

**20 Claims, 17 Drawing Sheets**

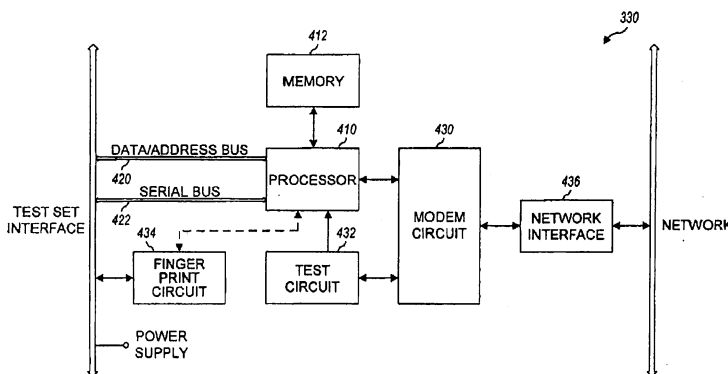

U.S. PATENT DOCUMENTS

4,887,260 A	12/1989	Carden et al.		5,790,432 A	8/1998	Morys	
4,894,829 A	1/1990	Monie et al.		5,805,571 A	9/1998	Zhan et al.	
4,922,516 A	5/1990	Butler et al.		5,812,786 A	9/1998	Seaholtz et al.	
4,996,695 A	2/1991	Dack et al.		5,847,749 A	12/1998	Proctor et al.	
5,121,342 A	6/1992	Szymborski et al.		5,850,209 A	12/1998	Lemke et al.	
5,173,896 A	12/1992	Dariano		5,864,662 A	1/1999	Brownmiller et al.	
5,227,988 A	7/1993	Sasaki et al.		5,884,202 A	3/1999	Arjomand	
5,251,150 A	10/1993	Ladner et al.		5,892,458 A	4/1999	Anderer et al.	
5,331,136 A	7/1994	Koenck		5,916,287 A	6/1999	Arjomand et al.	
5,363,366 A	* 11/1994	Wisdom et al. ....	370/245	5,920,608 A	7/1999	Minegishi	
5,377,128 A	12/1994	McBean		5,946,641 A	8/1999	Morys	
5,377,196 A	12/1994	Godlew et al.		5,956,385 A	9/1999	Soto et al.	
5,377,259 A	12/1994	Butler et al.		5,982,851 A	* 11/1999	Kennedy et al. ....	379/21
5,381,348 A	* 1/1995	Ernst et al. ....	324/533	6,002,671 A	* 12/1999	Kahkoska et al. ....	348/192
5,382,910 A	* 1/1995	Walsh .....	324/532	6,038,520 A	3/2000	Schoonover et al.	
5,432,705 A	7/1995	Severt et al.		6,064,721 A	* 5/2000	Mohammadian et al. ....	379/21
5,511,108 A	4/1996	Severt et al.		6,385,300 B1	5/2002	Mohammadian et al.	
5,521,958 A	5/1996	Selig et al.		6,590,963 B2	7/2003	Mohammadian et al.	
5,528,660 A	6/1996	Heins et al.		2003/0174813 A1	9/2003	Mohammadian et al.	
5,530,367 A	* 6/1996	Bottman .....	324/520				
5,533,093 A	7/1996	Horton et al.					
5,557,539 A	9/1996	Fitch					
5,566,088 A	10/1996	Herscher et al.					
5,567,925 A	10/1996	Koenck et al.					
5,583,912 A	12/1996	Schillaci et al.					
5,602,750 A	2/1997	Severt et al.					
5,608,644 A	3/1997	Debacker					
5,619,489 A	4/1997	Chang et al. ....	370/241				
5,644,573 A	7/1997	Bingham et al.					
5,715,437 A	2/1998	Baker et al.					
5,757,680 A	5/1998	Boston et al.					

OTHER PUBLICATIONS

“Traveling Wave Fault Location in Power Transmission Systems”, Application Note 1285, Hewlett-Packard Company, Feb. 1977, 5965-5296E.

“Accurate Transmission Line Fault Location Using Synchronized Sampling”, Application Note 1276-1, Hewlett-Packard Company, 1996, 5964-6640E.

“Time Domain Reflectometry Theory”, Application Note 1304-2, Hewlett-Packard Company, 1998, 5966-4855E.

\* cited by examiner

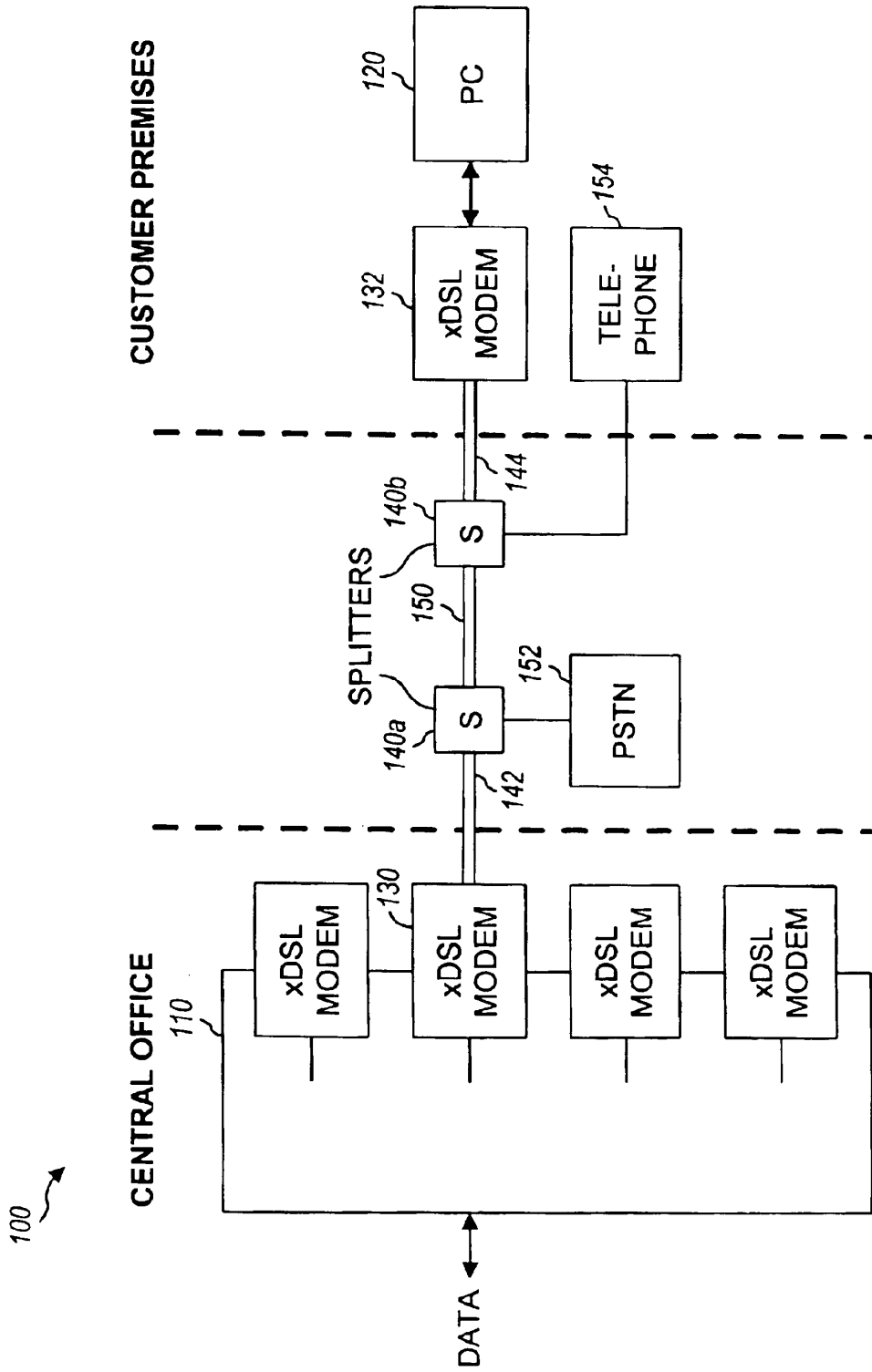

FIG. 1

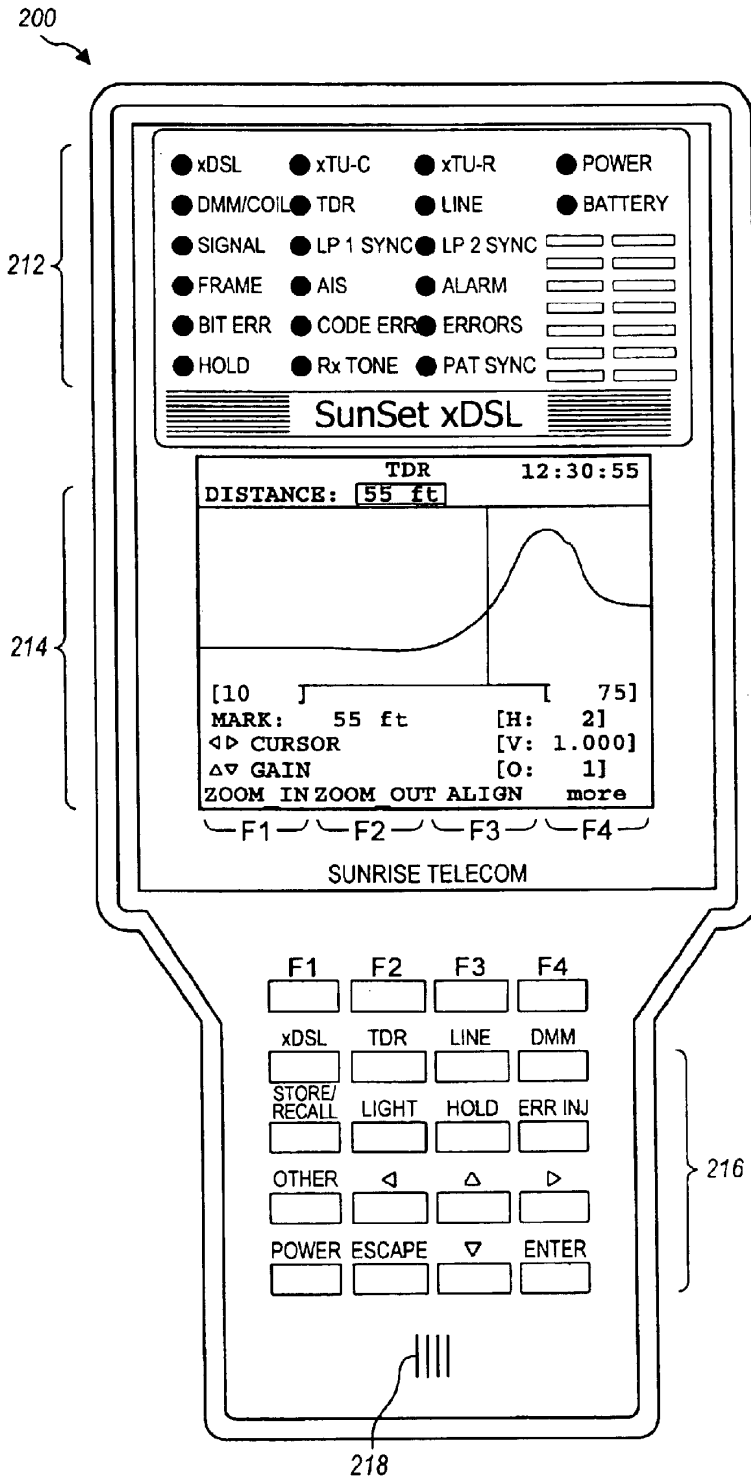

FIG. 2

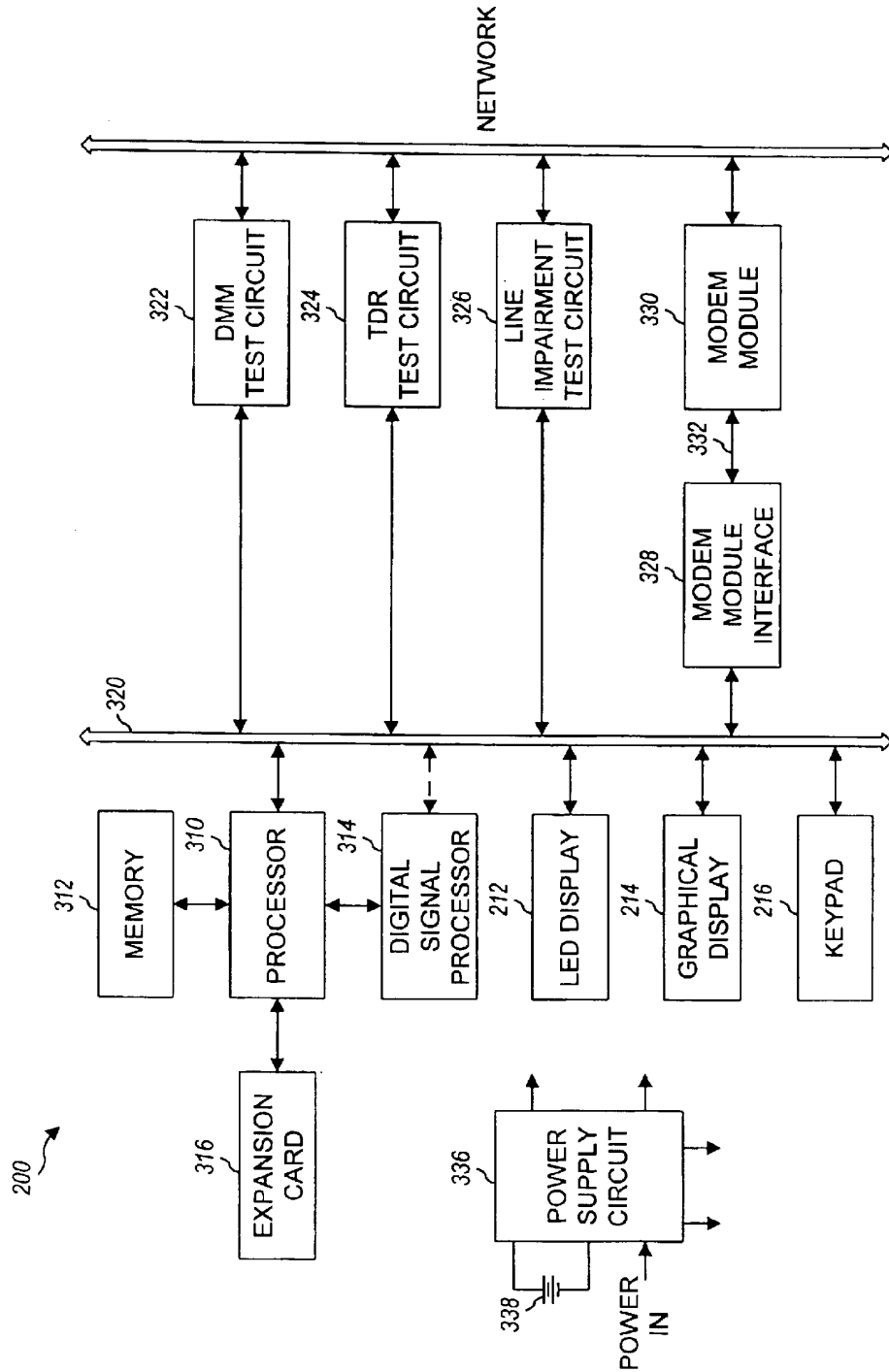

FIG. 3A

# Explore Litigation Insights

Docket Alarm provides insights to develop a more informed litigation strategy and the peace of mind of knowing you're on top of things.

## Real-Time Litigation Alerts



Keep your litigation team up-to-date with **real-time alerts** and advanced team management tools built for the enterprise, all while greatly reducing PACER spend.

Our comprehensive service means we can handle Federal, State, and Administrative courts across the country.

## Advanced Docket Research



With over 230 million records, Docket Alarm's cloud-native docket research platform finds what other services can't. Coverage includes Federal, State, plus PTAB, TTAB, ITC and NLRB decisions, all in one place.

Identify arguments that have been successful in the past with full text, pinpoint searching. Link to case law cited within any court document via Fastcase.

## Analytics At Your Fingertips



Learn what happened the last time a particular judge, opposing counsel or company faced cases similar to yours.

Advanced out-of-the-box PTAB and TTAB analytics are always at your fingertips.

## API

Docket Alarm offers a powerful API (application programming interface) to developers that want to integrate case filings into their apps.

## LAW FIRMS

Build custom dashboards for your attorneys and clients with live data direct from the court.

Automate many repetitive legal tasks like conflict checks, document management, and marketing.

## FINANCIAL INSTITUTIONS

Litigation and bankruptcy checks for companies and debtors.

## E-DISCOVERY AND LEGAL VENDORS

Sync your system to PACER to automate legal marketing.