

AO 120 (Rev. 08/10)

TO: <b>Mail Stop 8</b> <b>Director of the U.S. Patent and Trademark Office</b> P.O. Box 1450 Alexandria, VA 22313-1450	<b>REPORT ON THE                  FILING OR DETERMINATION OF AN                  ACTION REGARDING A PATENT OR                  TRADEMARK</b>
---	--

In Compliance with 35 U.S.C. § 290 and/or 15 U.S.C. § 1116 you are hereby advised that a court action has been filed in the U.S. District Court District of Delaware on the following

Trademarks or  Patents. (  the patent action involves 35 U.S.C. § 292.):

DOCKET NO. 15-cv-616-RGA	DATE FILED 7/17/2015	U.S. DISTRICT COURT District of Delaware
PLAINTIFF TQ Delta, LLC		DEFENDANT Verizon Communications Inc., Verizon Services Corp., Verizon Online LLC, Verizon Business Network Services Inc., Verizon Delaware LLC, and Verizon Information Technologies LLC
PATENT OR TRADEMARK NO.	DATE OF PATENT OR TRADEMARK	HOLDER OF PATENT OR TRADEMARK
1 See Attached		
2		
3		
4		
5		

In the above—entitled case, the following patent(s)/ trademark(s) have been included:

DATE INCLUDED 9/9/2015	INCLUDED BY <input checked="" type="checkbox"/> Amendment <input type="checkbox"/> Answer <input type="checkbox"/> Cross Bill <input type="checkbox"/> Other Pleading	
PATENT OR TRADEMARK NO.	DATE OF PATENT OR TRADEMARK	HOLDER OF PATENT OR TRADEMARK
1 US 9,094,268 B2	7/28/2015	TQ Delta, LLC
2		
3		
4		
5		

In the above—entitled case, the following decision has been rendered or judgement issued:

DECISION/JUDGEMENT		
CLERK	(BY) DEPUTY CLERK	DATE

Copy 1—Upon initiation of action, mail this copy to Director Copy 3—Upon termination of action, mail this copy to Director  
 Copy 2—Upon filing document adding patent(s), mail this copy to Director Copy 4—Case file copy

	PATENT OR TRADEMARK NO.	DATE OF PATENT OR TRADEMARK	HOLDER OF PATENT OR TRADEMARK
1	US 6,961,369 B1	11/1/2005	TQ Delta, LLC
2	US 8,718,158 B2	5/6/2014	TQ Delta, LLC
3	US 9,014,243 B2	4/21/2015	TQ Delta, LLC
4	US 7,835,430 B2	11/16/2010	TQ Delta, LLC
5	US 8,238,412 B2	8/7/2012	TQ Delta, LLC
6	US 8,432,956 B2	4/30/2013	TQ Delta, LLC
7	US 8,611,404 B2	12/17/2013	TQ Delta, LLC

AO 120 (Rev. 08/10)

TO: <b>Mail Stop 8</b> <b>Director of the U.S. Patent and Trademark Office</b> P.O. Box 1450 Alexandria, VA 22313-1450	<b>REPORT ON THE                  FILING OR DETERMINATION OF AN                  ACTION REGARDING A PATENT OR                  TRADEMARK</b>
---	--

In Compliance with 35 U.S.C. § 290 and/or 15 U.S.C. § 1116 you are hereby advised that a court action has been filed in the U.S. District Court District of Delaware on the following

Trademarks or  Patents. (  the patent action involves 35 U.S.C. § 292.):

DOCKET NO. 15-cv-615-RGA	DATE FILED 7/17/2015	U.S. DISTRICT COURT District of Delaware
PLAINTIFF TQ Delta, LLC		DEFENDANT Time Warner Cable Inc. and Time Warner Cable Enterprises LLC
PATENT OR TRADEMARK NO.	DATE OF PATENT OR TRADEMARK	HOLDER OF PATENT OR TRADEMARK
1 See Attached		
2		
3		
4		
5		

In the above—entitled case, the following patent(s)/ trademark(s) have been included:

DATE INCLUDED 9/9/2015	INCLUDED BY <input checked="" type="checkbox"/> Amendment <input type="checkbox"/> Answer <input type="checkbox"/> Cross Bill <input type="checkbox"/> Other Pleading	
PATENT OR TRADEMARK NO.	DATE OF PATENT OR TRADEMARK	HOLDER OF PATENT OR TRADEMARK
1 US 9,094,268 B2	7/28/2015	TQ Delta, LLC
2		
3		
4		
5		

In the above—entitled case, the following decision has been rendered or judgement issued:

DECISION/JUDGEMENT
--------------------

CLERK	(BY) DEPUTY CLERK	DATE
-------	-------------------	------

Copy 1—Upon initiation of action, mail this copy to Director Copy 3—Upon termination of action, mail this copy to Director  
 Copy 2—Upon filing document adding patent(s), mail this copy to Director Copy 4—Case file copy

	PATENT OR TRADEMARK NO.	DATE OF PATENT OR TRADEMARK	HOLDER OF PATENT OR TRADEMARK
1	US 6,961,369 B1	11/1/2005	TQ Delta, LLC
2	US 8,718,158 B2	5/6/2014	TQ Delta, LLC
3	US 9,014,243 B2	4/21/2015	TQ Delta, LLC
4	US 7,835,430 B2	11/16/2010	TQ Delta, LLC
5	US 8,238,412 B2	8/7/2012	TQ Delta, LLC
6	US 8,432,956 B2	4/30/2013	TQ Delta, LLC
7	US 8,611,404 B2	12/17/2013	TQ Delta, LLC

AO 120 (Rev. 08/10)

TO: <b>Mail Stop 8</b> <b>Director of the U.S. Patent and Trademark Office</b> P.O. Box 1450 Alexandria, VA 22313-1450	<b>REPORT ON THE                  FILING OR DETERMINATION OF AN                  ACTION REGARDING A PATENT OR                  TRADEMARK</b>
---	--

In Compliance with 35 U.S.C. § 290 and/or 15 U.S.C. § 1116 you are hereby advised that a court action has been filed in the U.S. District Court Middle District of Florida, Orlando Division on the following

Trademarks or  Patents. (  the patent action involves 35 U.S.C. § 292.):

DOCKET NO. 6:14-cv-1027	DATE FILED 6/26/2014	U.S. DISTRICT COURT Middle District of Florida, Orlando Division	
PLAINTIFF Orlando Communications LLC		DEFENDANT LG Electronics, Inc., et al	
PATENT OR TRADEMARK NO.	DATE OF PATENT OR TRADEMARK	HOLDER OF PATENT OR TRADEMARK	
1 5,687,1296	11/11/1997	James Arthur Proctor, Jr., James Carl Otto	
2 6,0009,553	12/28/0199	Dennis Martinez, Thomas Hengeveld, Michael Axford	
3			
4			
5			

In the above—entitled case, the following patent(s)/ trademark(s) have been included:

DATE INCLUDED	INCLUDED BY <input type="checkbox"/> Amendment <input type="checkbox"/> Answer <input type="checkbox"/> Cross Bill <input type="checkbox"/> Other Pleading		
PATENT OR TRADEMARK NO.	DATE OF PATENT OR TRADEMARK	HOLDER OF PATENT OR TRADEMARK	
1			
2			
3			
4			
5			

In the above—entitled case, the following decision has been rendered or judgement issued:

DECISION/JUDGEMENT Order of Dismissal
--

CLERK Sheryl Loesch	(BY) DEPUTY CLERK R. Olsen	DATE 9/9/2015
------------------------	-------------------------------	------------------

Copy 1—Upon initiation of action, mail this copy to Director    Copy 3—Upon termination of action, mail this copy to Director  
 Copy 2—Upon filing document adding patent(s), mail this copy to Director    Copy 4—Case file copy

AO 120 (Rev. 08/10)

TO: <b>Mail Stop 8</b> <b>Director of the U.S. Patent and Trademark Office</b> P.O. Box 1450 Alexandria, VA 22313-1450	<b>REPORT ON THE                  FILING OR DETERMINATION OF AN                  ACTION REGARDING A PATENT OR                  TRADEMARK</b>
---	--

In Compliance with 35 U.S.C. § 290 and/or 15 U.S.C. § 1116 you are hereby advised that a court action has been filed in the U.S. District Court Middle District of Florida, Orlando Division on the following  
 Trademarks or  Patents. (  the patent action involves 35 U.S.C. § 292.):

DOCKET NO. 6:14-cv-1026	DATE FILED 6/26/2014	U.S. DISTRICT COURT Middle District of Florida, Orlando Division
PLAINTIFF Orlando Communications LLC		DEFENDANT LG Electronics, Inc., et al
PATENT OR TRADEMARK NO.	DATE OF PATENT OR TRADEMARK	HOLDER OF PATENT OR TRADEMARK
1 5,687,1296	11/11/1997	James Arthur Proctor, Jr., James Carl Otto
2 6,0009,553	12/28/0199	Dennis Martinez, Thomas Hengeveld, Michael Axford
3		
4		
5		

In the above—entitled case, the following patent(s)/ trademark(s) have been included:

DATE INCLUDED	INCLUDED BY <input type="checkbox"/> Amendment <input type="checkbox"/> Answer <input type="checkbox"/> Cross Bill <input type="checkbox"/> Other Pleading	
PATENT OR TRADEMARK NO.	DATE OF PATENT OR TRADEMARK	HOLDER OF PATENT OR TRADEMARK
1		
2		
3		
4		
5		

In the above—entitled case, the following decision has been rendered or judgement issued:

DECISION/JUDGEMENT Order of Dismissal
--

CLERK Sheryl Loesch	(BY) DEPUTY CLERK R. Olsen	DATE 9/9/2015
------------------------	-------------------------------	------------------

Copy 1—Upon initiation of action, mail this copy to Director    Copy 3—Upon termination of action, mail this copy to Director  
 Copy 2—Upon filing document adding patent(s), mail this copy to Director    Copy 4—Case file copy

AO 120 (Rev. 08/10) TO: <b>Mail Stop 8</b> <b>Director of the U.S. Patent and Trademark Office</b> <b>P.O. Box 1450</b> <b>Alexandria, VA 22313-1450</b>	<b>REPORT ON THE                  FILING OR DETERMINATION OF AN                  ACTION REGARDING A PATENT OR                  TRADEMARK</b>
--	--

In Compliance with 35 U.S.C. § 290 and/or 15 U.S.C. § 1116 you are hereby advised that a court action has been filed in the U.S. District Court Middle District of Florida, Orlando Division on the following

Trademarks or  Patents. (  the patent action involves 35 U.S.C. § 292.):

DOCKET NO. 6:14-cv-1028	DATE FILED 6/26/2014	U.S. DISTRICT COURT Middle District of Florida, Orlando Division	
PLAINTIFF Orlando Communications LLC		DEFENDANT HTC Corporation, et al	
PATENT OR TRADEMARK NO.	DATE OF PATENT OR TRADEMARK	HOLDER OF PATENT OR TRADEMARK	
1 5,687,1296	11/11/1997	James Arthur Proctor, Jr., James Carl Otto	
2 6,0009,553	12/28/0199	Dennis Martinez, Thomas Hengeveld, Michael Axford	
3			
4			
5			

In the above—entitled case, the following patent(s)/ trademark(s) have been included:

DATE INCLUDED	INCLUDED BY <input type="checkbox"/> Amendment <input type="checkbox"/> Answer <input type="checkbox"/> Cross Bill <input type="checkbox"/> Other Pleading		
PATENT OR TRADEMARK NO.	DATE OF PATENT OR TRADEMARK	HOLDER OF PATENT OR TRADEMARK	
1			
2			
3			
4			
5			

In the above—entitled case, the following decision has been rendered or judgement issued:

DECISION/JUDGEMENT Order of Dismissal
--

CLERK Sheryl Loesch	(BY) DEPUTY CLERK R. Olsen	DATE 9/9/2015
------------------------	-------------------------------	------------------

Copy 1—Upon initiation of action, mail this copy to Director Copy 3—Upon termination of action, mail this copy to Director  
 Copy 2—Upon filing document adding patent(s), mail this copy to Director Copy 4—Case file copy

AO 120 (Rev. 08/10)

TO: <b>Mail Stop 8</b> <b>Director of the U.S. Patent and Trademark Office</b> <b>P.O. Box 1450</b> <b>Alexandria, VA 22313-1450</b>	<b>REPORT ON THE</b> <b>FILING OR DETERMINATION OF AN</b> <b>ACTION REGARDING A PATENT OR</b> <b>TRADEMARK</b>
---	---

In Compliance with 35 U.S.C. § 290 and/or 15 U.S.C. § 1116 you are hereby advised that a court action has been filed in the U.S. District Court Delaware on the following  
 Trademarks or  Patents. (  the patent action involves 35 U.S.C. § 292.);

DOCKET NO.	DATE FILED 9/4/2013	U.S. DISTRICT COURT Delaware
PLAINTIFF ROCHE PALO ALTO LLC and GENENTECH, INC.		DEFENDANT WATSON LABORATORIES, INC. – FLORIDA
PATENT OR TRADEMARK NO.	DATE OF PATENT OR TRADEMARK	HOLDER OF PATENT OR TRADEMARK
1 6,083,953	7/4/2000	Roche Palo Alto LLC
2		
3		
4		
5		

In the above—entitled case, the following patent(s)/ trademark(s) have been included:

DATE INCLUDED	INCLUDED BY <input type="checkbox"/> Amendment <input type="checkbox"/> Answer <input type="checkbox"/> Cross Bill <input type="checkbox"/> Other Pleading		
PATENT OR TRADEMARK NO.	DATE OF PATENT OR TRADEMARK	HOLDER OF PATENT OR TRADEMARK	
1			
2			
3			
4			
5			

In the above—entitled case, the following decision has been rendered or judgement issued:

DECISION/JUDGEMENT  <i>Dismissed - See Attached</i>
---

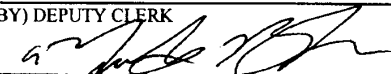
CLERK <b>John A Cerino, Clerk</b> <b>United States District Court</b> <b>844 N. King Street, Unit 18</b> <b>Wilmington, DE 19801</b>	(BY) DEPUTY CLERK 	DATE 7/17/15
---	---	-----------------

Copy 1—Upon initiation of action, mail this copy to Director    Copy 3—Upon termination of action, mail this copy to Director  
 Copy 2—Upon filing document adding patent(s), mail this copy to Director    Copy 4—Case file copy



AO 120 (Rev. 3/04)

TO: <b>Mail Stop 8</b> Director of the U.S. Patent and Trademark Office P.O. Box 1450 Alexandria, VA 22313-1450	<b>REPORT ON THE                  FILING OR DETERMINATION OF AN                  ACTION REGARDING A PATENT OR                  TRADEMARK</b>
--	--

In Compliance with 35 U.S.C. § 290 and/or 15 U.S.C. § 1116 you are hereby advised that a court action has been filed in the U.S. District Court Massachusetts on the following  Patents or  Trademarks:

DOCKET NO.	DATE FILED 7/17/2015	U.S. DISTRICT COURT Massachusetts
PLAINTIFF BOSTON PROPERTIES LIMITED PARTNERSHIP		DEFENDANT CLAUDETTE MOUSSA, d/b/a Boston Properties Advisors
PATENT OR TRADEMARK NO.	DATE OF PATENT OR TRADEMARK	HOLDER OF PATENT OR TRADEMARK
1 2,527,181	1/8/2002	BOSTON PROPERTIES LIMITED PARTNERSHIP
2		
3		
4		
5		

In the above—entitled case, the following patent(s)/ trademark(s) have been included:

DATE INCLUDED	INCLUDED BY <input checked="" type="checkbox"/> Amendment <input checked="" type="checkbox"/> Answer <input checked="" type="checkbox"/> Cross Bill <input checked="" type="checkbox"/> Other Pleading		
PATENT OR TRADEMARK NO.	DATE OF PATENT OR TRADEMARK	HOLDER OF PATENT OR TRADEMARK	
1			
2			
3			
4			
5			

In the above—entitled case, the following decision has been rendered or judgement issued:

DECISION/JUDGEMENT
--------------------

CLERK	(BY) DEPUTY CLERK	DATE
-------	-------------------	------

Copy 1—Upon initiation of action, mail this copy to Director Copy 3—Upon termination of action, mail this copy to Director  
 Copy 2—Upon filing document adding patent(s), mail this copy to Director Copy 4—Case file copy

AO 120 (Rev. 08/10)

TO: <b>Mail Stop 8 Director of the U.S. Patent and Trademark Office P.O. Box 1450 Alexandria, VA 22313-1450</b>	<b>REPORT ON THE FILING OR DETERMINATION OF AN ACTION REGARDING A PATENT OR TRADEMARK</b>
---	---

In Compliance with 35 U.S.C. § 290 and/or 15 U.S.C. § 1116 you are hereby advised that a court action has been filed in the U.S. District Court District of Delaware on the following  
 Trademarks or  Patents. (  the patent action involves 35 U.S.C. § 292.):

DOCKET NO.	DATE FILED 7/17/2015	U.S. DISTRICT COURT District of Delaware
PLAINTIFF TQ Delta, LLC		DEFENDANT Verizon Communications Inc., Verizon Services Corp., Verizon Online LLC, Verizon Business Network Services Inc., Verizon Delaware LLC, and Verizon Information Technologies LLC
PATENT OR TRADEMARK NO.	DATE OF PATENT OR TRADEMARK	HOLDER OF PATENT OR TRADEMARK
1 See Attached		
2		
3		
4		
5		

In the above—entitled case, the following patent(s)/ trademark(s) have been included:

DATE INCLUDED	INCLUDED BY <input type="checkbox"/> Amendment <input type="checkbox"/> Answer <input type="checkbox"/> Cross Bill <input type="checkbox"/> Other Pleading	
PATENT OR TRADEMARK NO.	DATE OF PATENT OR TRADEMARK	HOLDER OF PATENT OR TRADEMARK
1		
2		
3		
4		
5		

In the above—entitled case, the following decision has been rendered or judgement issued:

DECISION/JUDGEMENT
--------------------

CLERK	(BY) DEPUTY CLERK	DATE
-------	-------------------	------

Copy 1—Upon initiation of action, mail this copy to Director Copy 3—Upon termination of action, mail this copy to Director  
 Copy 2—Upon filing document adding patent(s), mail this copy to Director Copy 4—Case file copy

	PATENT OR TRADEMARK NO.	DATE OF PATENT OR TRADEMARK	HOLDER OF PATENT OR TRADEMARK
1	US 6,961,369 B1	11/1/2005	TQ Delta, LLC
2	US 8,718,158 B2	5/6/2014	TQ Delta, LLC
3	US 9,014,243 B2	4/21/2015	TQ Delta, LLC
4	US 7,835,430 B2	11/16/2010	TQ Delta, LLC
5	US 8,238,412 B2	8/7/2012	TQ Delta, LLC
6	US 8,432,956 B2	4/30/2013	TQ Delta, LLC
7	US 8,611,404 B2	12/17/2013	TQ Delta, LLC

AO 120 (Rev. 08/10)

TO: <b>Mail Stop 8</b> <b>Director of the U.S. Patent and Trademark Office</b> P.O. Box 1450 Alexandria, VA 22313-1450	<b>REPORT ON THE                  FILING OR DETERMINATION OF AN                  ACTION REGARDING A PATENT OR                  TRADEMARK</b>
---	--

In Compliance with 35 U.S.C. § 290 and/or 15 U.S.C. § 1116 you are hereby advised that a court action has been filed in the U.S. District Court Transferred to Delaware from Alabama on the following  
 Trademarks or  Patents. (  the patent action involves 35 U.S.C. § 292.);

DOCKET NO. 15-cv-121-RGA	DATE FILED 7/17/2014	U.S. DISTRICT COURT Transferred to Delaware from Alabama
PLAINTIFF ADTRAN, Inc.		DEFENDANT TQ Delta, LLC
PATENT OR TRADEMARK NO.	DATE OF PATENT OR TRADEMARK	HOLDER OF PATENT OR TRADEMARK
1 See Attachment #1		
2		
3		
4		
5		

In the above—entitled case, the following patent(s)/ trademark(s) have been included:

DATE INCLUDED 3/13/2015	INCLUDED BY <input type="checkbox"/> Amendment <input checked="" type="checkbox"/> Answer <input type="checkbox"/> Cross Bill <input type="checkbox"/> Other Pleading	
PATENT OR TRADEMARK NO.	DATE OF PATENT OR TRADEMARK	HOLDER OF PATENT OR TRADEMARK
1 See Attachment #2		
2		
3		
4		
5		

In the above—entitled case, the following decision has been rendered or judgement issued:

DECISION/JUDGEMENT
--------------------

CLERK	(BY) DEPUTY CLERK	DATE
-------	-------------------	------

Copy 1—Upon initiation of action, mail this copy to Director Copy 3—Upon termination of action, mail this copy to Director  
 Copy 2—Upon filing document adding patent(s), mail this copy to Director Copy 4—Case file copy

Attachment #1

Patent or Trademark No.	Date of Patent or Trademark	Holder of Patent or Trademark
1.U.S. 7,453,881 B2	11/18/2008	TQ Delta, LLC
2.U.S. 7,809,028 B2	10/05/2010	TQ Delta, LLC
3.U.S. 7,978,706 B2	7/12/2011	TQ Delta, LLC
4.U.S. 8,422,511 B2	4/16/2013	TQ Delta, LLC
5.U.S. 6,445,730 B1	9/03/2002	TQ Delta, LLC
6.U.S. 7,292,627 B2	11/6/2007	TQ Delta, LLC
7.U.S. 7,451,379 B2	11/11/2008	TQ Delta, LLC
8.U.S. 7,471,721 B2	12/30/2008	TQ Delta, LLC
9.U.S. 7,570,686 B2	8/4/2009	TQ Delta, LLC
10. U.S. 7,831,890 B2	11/09/2010	TQ Delta, LLC
11. U.S. 7,835,430 B2	11/16/2010	TQ Delta, LLC
12. U.S. 7,836,381 B1	11/16/2010	TQ Delta, LLC
13. U.S. 7,844,882 B2	11/30/2010	TQ Delta, LLC
14. U.S. 7,889,784 B2	2/15/2011	TQ Delta, LLC
15. U.S. 7,925,958 B2	04/12/2011	TQ Delta, LLC
16. U.S. 7,978,753 B2	07/12/2011	TQ Delta, LLC
17. U.S. 7,979,778 B2	07/12/2011	TQ Delta, LLC
18. U.S. 8,073,041 B1	12/6/2011	TQ Delta, LLC
19. U.S. 8,090,008 B2	1/3/2012	TQ Delta, LLC
20. U.S. 8,218,610 B2	7/10/2012	TQ Delta, LLC
21. U.S. 8,238,412 B2	08/07/2012	TQ Delta, LLC
22. U.S. 8,276,048 B2	09/25/2012	TQ Delta, LLC
23. U.S. 8,355,427 B2	1/15/2013	TQ Delta, LLC

24. U.S. 8,432,956 B2	4/30/2013	TQ Delta, LLC
25. U.S. 8,437,382 B2	5/7/2013	TQ Delta, LLC
26. U.S. 8,462,835 B2	6/11/2013	TQ Delta, LLC
27. U.S. 8,495,473 B2	7/23/2013	TQ Delta, LLC
28. U.S. 8,516,337 B2	08/20/2013	TQ Delta, LLC

	PATENT OR TRADEMARK NO.	DATE OF PATENT OR TRADEMARK	HOLDER OF PATENT OR TRADEMARK
1	US 7,796,705 B2	9/14/2010	TQ Delta, LLC
2	US 8,335,956 B2	12/18/2012	TQ Delta, LLC
3	US 8,407,546 B2	3/26/2013	TQ Delta, LLC
4	US 8,468,411 B2	6/18/2013	TQ Delta, LLC
5	US 8,645,784 B2	2/4/2014	TQ Delta, LLC
6	US 8,595,577 B2	11/26/2013	TQ Delta, LLC

AO 120 (Rev. 08/10)

TO: <b>Mail Stop 8</b> <b>Director of the U.S. Patent and Trademark Office</b> P.O. Box 1450 Alexandria, VA 22313-1450	<b>REPORT ON THE                  FILING OR DETERMINATION OF AN                  ACTION REGARDING A PATENT OR                  TRADEMARK</b>
---	--

In Compliance with 35 U.S.C. § 290 and/or 15 U.S.C. § 1116 you are hereby advised that a court action has been filed in the U.S. District Court District of Delaware on the following  
 Trademarks or  Patents. (  the patent action involves 35 U.S.C. § 292.);

DOCKET NO.	DATE FILED 7/18/2014	U.S. DISTRICT COURT District of Delaware
PLAINTIFF TQ Delta, LLC		DEFENDANT ADTRAN, Inc.
PATENT OR TRADEMARK NO.	DATE OF PATENT OR TRADEMARK	HOLDER OF PATENT OR TRADEMARK
1 See Attached		
2 32 Pats		
3		
4		
5		

In the above—entitled case, the following patent(s)/ trademark(s) have been included:

DATE INCLUDED	INCLUDED BY <input type="checkbox"/> Amendment <input type="checkbox"/> Answer <input type="checkbox"/> Cross Bill <input type="checkbox"/> Other Pleading	
PATENT OR TRADEMARK NO.	DATE OF PATENT OR TRADEMARK	HOLDER OF PATENT OR TRADEMARK
1		
2		
3		
4		
5		

In the above—entitled case, the following decision has been rendered or judgement issued:

DECISION/JUDGEMENT
--------------------

CLERK	(BY) DEPUTY CLERK	DATE
-------	-------------------	------

Copy 1—Upon initiation of action, mail this copy to Director    Copy 3—Upon termination of action, mail this copy to Director  
 Copy 2—Upon filing document adding patent(s), mail this copy to Director    Copy 4—Case file copy



	PATENT OR TRADEMARK NO.	DATE OF PATENT OR TRADEMARK	HOLDER OF PATENT OR TRADEMARK
1	US 8,090,008 B2	1/3/2012	TQ Delta, LLC
2	US 8,073,041 B1	12/6/2011	TQ Delta, LLC
3	US 7,292,627 B2	11/6/2007	TQ Delta, LLC
4	US 7,471,721 B2	12/30/2008	TQ Delta, LLC
5	US 8,218,610 B2	7/10/2012	TQ Delta, LLC
6	US 8,355,427 B2	1/15/2013	TQ Delta, LLC
7	US 7,453,881 B2	11/18/2008	TQ Delta, LLC
8	US 7,809,028 B2	10/5/2010	TQ Delta, LLC
9	US 7,978,706 B2	7/12/2011	TQ Delta, LLC
10	US 8,422,511 B2	4/16/2013	TQ Delta, LLC
11	US 7,889,784 B2	2/15/2011	TQ Delta, LLC
12	US 7,835,430 B2	11/16/2010	TQ Delta, LLC
13	US 7,570,686 B2	8/4/2009	TQ Delta, LLC
14	US 8,238,412 B2	8/7/2012	TQ Delta, LLC
15	US 8,432,956 B2	4/30/2013	TQ Delta, LLC
16	US 7,451,379 B2	11/11/2008	TQ Delta, LLC
17	US 8,516,337 B2	8/20/2013	TQ Delta, LLC
18	US 7,979,778 B2	7/12/2011	TQ Delta, LLC
19	US 7,925,958 B2	4/12/2011	TQ Delta, LLC
20	US 8,462,835 B2	6/11/2013	TQ Delta, LLC
21	US 8,594,162 B2	11/26/2013	TQ Delta, LLC
22	US 7,978,753 B2	7/12/2011	TQ Delta, LLC
23	US 6,445,730 B1	9/3/2002	TQ Delta, LLC
24	US 8,611,404 B2	12/17/2013	TQ Delta, LLC
25	US 8,437,382 B2	5/7/2013	TQ Delta, LLC
26	US 7,836,381 B1	11/16/2010	TQ Delta, LLC
27	US 7,844,882 B2	11/30/2010	TQ Delta, LLC
28	US 8,276,048 B2	9/25/2012	TQ Delta, LLC
29	US 8,495,473 B2	7/23/2013	TQ Delta, LLC
30	US 8,607,126 B1	12/10/2013	TQ Delta, LLC
31	US 7,831,890 B2	11/9/2010	TQ Delta, LLC
32	US 8,625,660 B2	1/7/2014	TQ Delta, LLC

**Birch, Melvin (Akima)**

---

**From:** ded\_nefreply@ded.uscourts.gov  
**Sent:** Wednesday, November 20, 2013 4:56 PM  
**To:** ded\_ecf@ded.uscourts.gov  
**Subject:** Activity in Case 1:13-cv-01835-RGA TQ Delta LLC v. Pace Americas Inc.  
Patent/Trademark Report to Commissioner

This is an automatic e-mail message generated by the CM/ECF system. Please **DO NOT RESPOND** to this e-mail because the mail box is unattended.

**\*\*\*NOTE TO PUBLIC ACCESS USERS\*\*\*** Judicial Conference of the United States policy permits attorneys of record and parties in a case (including pro se litigants) to receive one free electronic copy of all documents filed electronically, if receipt is required by law or directed by the filer. PACER access fees apply to all other users. To avoid later charges, download a copy of each document during this first viewing. However, if the referenced document is a transcript, the free copy and 30 page limit do not apply.

U.S. District Court

District of Delaware

**Notice of Electronic Filing**

The following transaction was entered by Farnan, Brian on 11/20/2013 at 4:56 PM EST and filed on 11/20/2013

**Case Name:** TQ Delta LLC v. Pace Americas Inc.

**Case Number:** 1:13-cv-01835-RGA

**Filer:**

**Document Number:** 7

**Docket Text:**

**Report to the Commissioner of Patents and Trademarks for Patent/Trademark Number(s) US 8,090,008 B2; US 8,073,041 B1; US 7,292,627 B2; US 7,471,721 B2; US 8,218,610 B2; US 8,355,427 B2; US 7,453,881 B2; US 7,978,706 B2; US 8,422,511 B2; US 7,889,784 B2; US 7,835,430 B2; US 7,570,686 B2; US 8,238,412 B2; US 8,432,956 B2; US 7,451,379 B2; US 8,516,337 B2; US 7,979,778 B2; US 7,925,958 B2; US 8,462,835 B2; US 7,836,381 B1; US 7,844,882 B2; US 8,276,048 B2; US 8,495,473 B2; US 7,831,890 B2; . (Farnan, Brian)**

**1:13-cv-01835-RGA Notice has been electronically mailed to:**

Brian E. Farnan [bfarnan@farnanlaw.com](mailto:bfarnan@farnanlaw.com), [tfarnan@farnanlaw.com](mailto:tfarnan@farnanlaw.com)

Michael J. Farnan [mfarnan@farnanlaw.com](mailto:mfarnan@farnanlaw.com), [tfarnan@farnanlaw.com](mailto:tfarnan@farnanlaw.com)

**1:13-cv-01835-RGA Filer will deliver document by other means to:**

The following document(s) are associated with this transaction:

**From:** ded\_nefreply@ded.uscourts.gov  
**Sent:** Wednesday, November 20, 2013 5:07 PM  
**To:** ded\_ecf@ded.uscourts.gov  
**Subject:** Activity in Case 1:13-cv-01836-RGA TQ Delta LLC v. Zhone Technologies Inc.  
Patent/Trademark Report to Commissioner

This is an automatic e-mail message generated by the CM/ECF system. Please **DO NOT RESPOND** to this e-mail because the mail box is unattended.

**\*\*\*NOTE TO PUBLIC ACCESS USERS\*\*\*** Judicial Conference of the United States policy permits attorneys of record and parties in a case (including pro se litigants) to receive one free electronic copy of all documents filed electronically, if receipt is required by law or directed by the filer. PACER access fees apply to all other users. To avoid later charges, download a copy of each document during this first viewing. However, if the referenced document is a transcript, the free copy and 30 page limit do not apply.

**U.S. District Court**

**District of Delaware**

#### **Notice of Electronic Filing**

The following transaction was entered by Farnan, Brian on 11/20/2013 at 5:07 PM EST and filed on 11/20/2013

**Case Name:** TQ Delta LLC v. Zhone Technologies Inc.

**Case Number:** 1:13-cv-01836-RGA

**Filer:**

**Document Number:** 7

#### **Docket Text:**

**Report to the Commissioner of Patents and Trademarks for Patent/Trademark Number(s) US 8,090,008 B2; US 8,073,041 B1; US 7,292,627 B2; US 7,471,721 B2; US 8,218,610 B2; US 8,355,427 B2; US 7,453,881 B2; US 7,809,028 B2; US 7,978,706 B2; US 8,422,511 B2; US 7,796,705 B2; US 7,889,784 B2; US 7,835,430 B2; US 7,570,686 B2; US 8,238,412 B2; US 8,432,956 B2; US 7,451,379 B2; US 8,516,337 B2; US 7,979,778 B2; US 7,925,958 B2; US 8,462,835 B2; US 7,978,753 B2; US 6,445,730 B1; US 8,437,382 B2; US 7,836,381 B1; US 7,844,882 B2; US 8,276,048 B2; US 8,495,473 B2; US 7,831,890 B2; US 8,335,956 B2; US 8,468,411 B2; US 8,407,546 B2 . (Farnan, Brian)**

**1:13-cv-01836-RGA Notice has been electronically mailed to:**

Brian E. Farnan [bfarnan@farnanlaw.com](mailto:bfarnan@farnanlaw.com), [tfarnan@farnanlaw.com](mailto:tfarnan@farnanlaw.com)

Michael J. Farnan [mfarnan@farnanlaw.com](mailto:mfarnan@farnanlaw.com), [tfarnan@farnanlaw.com](mailto:tfarnan@farnanlaw.com)

**1:13-cv-01836-RGA Filer will deliver document by other means to:**

AO 120 (Rev. 08/10)

TO: <b>Mail Stop 8</b> <b>Director of the U.S. Patent and Trademark Office</b> <b>P.O. Box 1450</b> <b>Alexandria, VA 22313-1450</b>	<b>REPORT ON THE</b> <b>FILING OR DETERMINATION OF AN</b> <b>ACTION REGARDING A PATENT OR</b> <b>TRADEMARK</b>
---	---

In Compliance with 35 U.S.C. § 290 and/or 15 U.S.C. § 1116 you are hereby advised that a court action has been filed in the U.S. District Court District of Delaware on the following  
 Trademarks or  Patents. (  the patent action involves 35 U.S.C. § 292.);

DOCKET NO.	DATE FILED 12/9/2013	U.S. DISTRICT COURT District of Delaware
PLAINTIFF TQ Delta, LLC		DEFENDANT ZyXEL Communications Corporation and ZyXEL Communications, Inc.
PATENT OR TRADEMARK NO.	DATE OF PATENT OR TRADEMARK	HOLDER OF PATENT OR TRADEMARK
1 See Attached		
2		
3		
4		
5		

In the above—entitled case, the following patent(s)/ trademark(s) have been included:

DATE INCLUDED	INCLUDED BY <input type="checkbox"/> Amendment <input type="checkbox"/> Answer <input type="checkbox"/> Cross Bill <input type="checkbox"/> Other Pleading
PATENT OR TRADEMARK NO.	DATE OF PATENT OR TRADEMARK HOLDER OF PATENT OR TRADEMARK
1	
2	
3	
4	
5	

In the above—entitled case, the following decision has been rendered or judgement issued:

DECISION/JUDGEMENT
--------------------

CLERK	(BY) DEPUTY CLERK	DATE
-------	-------------------	------

Copy 1—Upon initiation of action, mail this copy to Director    Copy 3—Upon termination of action, mail this copy to Director  
 Copy 2—Upon filing document adding patent(s), mail this copy to Director    Copy 4—Case file copy

	PATENT OR TRADEMARK NO.	DATE OF PATENT OR TRADEMARK	HOLDER OF PATENT OR TRADEMARK
1	US 8,090,008 B2	1/3/2012	TQ Delta, LLC
2	US 8,073,041 B1	12/6/2011	TQ Delta, LLC
3	US 7,292,627 B2	11/6/2007	TQ Delta, LLC
4	US 7,471,721 B2	12/30/2008	TQ Delta, LLC
5	US 8,218,610 B2	7/10/2012	TQ Delta, LLC
6	US 8,355,427 B2	1/15/2013	TQ Delta, LLC
7	US 7,453,881 B2	11/18/2008	TQ Delta, LLC
8	US 7,809,028 B2	10/5/2010	TQ Delta, LLC
9	US 7,978,706 B2	7/12/2011	TQ Delta, LLC
10	US 8,422,511 B2	4/16/2013	TQ Delta, LLC
11	US 7,796,705 B2	9/14/2010	TQ Delta, LLC
12	US 7,889,784 B2	2/15/2011	TQ Delta, LLC
13	US 7,835,430 B2	11/16/2010	TQ Delta, LLC
14	US 7,570,686 B2	8/4/2009	TQ Delta, LLC
15	US 8,238,412 B2	8/7/2012	TQ Delta, LLC
16	US 8,432,956 B2	4/30/2013	TQ Delta, LLC
17	US 7,451,379 B2	11/11/2008	TQ Delta, LLC
18	US 8,516,337 B2	8/20/2013	TQ Delta, LLC
19	US 7,979,778 B2	7/12/2011	TQ Delta, LLC
20	US 7,925,958 B2	4/12/2011	TQ Delta, LLC
21	US 8,462,835 B2	6/11/2013	TQ Delta, LLC
22	US 7,978,753 B2	7/12/2011	TQ Delta, LLC
23	US 6,445,730 B1	9/3/2002	TQ Delta, LLC
24	US 8,437,382 B2	5/7/2013	TQ Delta, LLC
25	US 7,836,381 B1	11/16/2010	TQ Delta, LLC
26	US 7,844,882 B2	11/30/2010	TQ Delta, LLC
27	US 8,276,048 B2	9/25/2012	TQ Delta, LLC
28	US 8,495,473 B2	7/23/2013	TQ Delta, LLC
29	US 7,831,890 B2	11/9/2010	TQ Delta, LLC
30	US 8,335,956 B2	12/18/2012	TQ Delta, LLC
31	US 8,468,411 B2	6/18/2013	TQ Delta, LLC
32	US 8,407,546 B2	3/26/2013	TQ Delta, LLC

<b>Mail Stop 8</b> <b>TO: Director of the U.S. Patent and Trademark Office</b> <b>P.O. Box 1450</b> <b>Alexandria, VA 22313-1450</b>	<b>REPORT ON THE</b> <b>FILING OR DETERMINATION OF AN</b> <b>ACTION REGARDING A PATENT OR</b> <b>TRADEMARK</b>
---	---

In Compliance with 35 U.S.C. § 290 and/or 15 U.S.C. § 1116 you are hereby advised that a court action has been filed in the U.S. District Court Northern District of Texas, Dallas Division on the following

Trademarks or  Patents. (  the patent action involves 35 U.S.C. § 292.);

DOCKET NO. 3:12-cv-1462-L	DATE FILED 5/10/2012	U.S. DISTRICT COURT Northern District of Texas, Dallas Division
PLAINTIFF Boulle Ltd		DEFENDANT De Boulle Diamond & Jewelry Inc
PATENT OR TRADEMARK NO.	DATE OF PATENT OR TRADEMARK	HOLDER OF PATENT OR TRADEMARK
1 4,086,050	1/17/2012	Boulle Ltd
2		
3		
4		
5		

In the above—entitled case, the following patent(s)/ trademark(s) have been included:

DATE INCLUDED 12/9/2013	INCLUDED BY <input checked="" type="checkbox"/> Amendment <input type="checkbox"/> Answer <input type="checkbox"/> Cross Bill <input type="checkbox"/> Other Pleading	
PATENT OR TRADEMARK NO.	DATE OF PATENT OR TRADEMARK	HOLDER OF PATENT OR TRADEMARK
1 3,078,625	4/11/2006	De Boulle Diamond & Jewelry Inc
2 3,078,627	4/11/2006	De Boulle Diamond & Jewelry Inc
3		
4		
5		

In the above—entitled case, the following decision has been rendered or judgement issued:

DECISION/JUDGEMENT
--------------------

CLERK Karen Mitchell	(BY) DEPUTY CLERK s/A. Lowe-Monserrate	DATE 12/10/2013
-------------------------	---	--------------------

Copy 1—Upon initiation of action, mail this copy to Director Copy 3—Upon termination of action, mail this copy to Director  
 Copy 2—Upon filing document adding patent(s), mail this copy to Director Copy 4—Case file copy

AO 120 (Rev. 08/10)

TO: <b>Mail Stop 8</b> <b>Director of the U.S. Patent and Trademark Office</b> P.O. Box 1450 Alexandria, VA 22313-1450	<b>REPORT ON THE                  FILING OR DETERMINATION OF AN                  ACTION REGARDING A PATENT OR                  TRADEMARK</b>
---	--

In Compliance with 35 U.S.C. § 290 and/or 15 U.S.C. § 1116 you are hereby advised that a court action has been filed in the U.S. District Court District of Delaware on the following

Trademarks or  Patents. (  the patent action involves 35 U.S.C. § 292.);

DOCKET NO.	DATE FILED 11/4/2013	U.S. DISTRICT COURT District of Delaware
PLAINTIFF TQ Delta, LLC		DEFENDANT Pace Americas, Inc.
PATENT OR TRADEMARK NO.	DATE OF PATENT OR TRADEMARK	HOLDER OF PATENT OR TRADEMARK
1 See Attached		
2		
3		
4		
5		

In the above—entitled case, the following patent(s)/ trademark(s) have been included:

DATE INCLUDED	INCLUDED BY <input type="checkbox"/> Amendment <input type="checkbox"/> Answer <input type="checkbox"/> Cross Bill <input type="checkbox"/> Other Pleading	
PATENT OR TRADEMARK NO.	DATE OF PATENT OR TRADEMARK	HOLDER OF PATENT OR TRADEMARK
1		
2		
3		
4		
5		

In the above—entitled case, the following decision has been rendered or judgement issued:

DECISION/JUDGEMENT
--------------------

CLERK	(BY) DEPUTY CLERK	DATE
-------	-------------------	------

Copy 1—Upon initiation of action, mail this copy to Director    Copy 3—Upon termination of action, mail this copy to Director  
 Copy 2—Upon filing document adding patent(s), mail this copy to Director    Copy 4—Case file copy

PATENT OR TRADEMARK NO.	DATE OF PATENT OR TRADEMARK	HOLDER OF PATENT OR TRADEMARK
1 US 8,090,008 B2	1/3/2012	TQ Delta, LLC
2 US 8,073,041 B1	12/6/2011	TQ Delta, LLC
3 US 7,292,627 B2	11/6/2007	TQ Delta, LLC
4 US 7,471,721 B2	12/30/2008	TQ Delta, LLC
5 US 8,218,610 B2	7/10/2012	TQ Delta, LLC
6 US 8,355,427 B2	1/15/2013	TQ Delta, LLC
7 US 7,453,881 B2	11/18/2008	TQ Delta, LLC
8 US 7,978,706 B2	7/12/2011	TQ Delta, LLC
9 US 8,422,511 B2	4/16/2013	TQ Delta, LLC
10 US 7,889,784 B2	2/15/2011	TQ Delta, LLC
11 US 7,835,430 B2	11/16/2010	TQ Delta, LLC
12 US 7,570,686 B2	8/4/2009	TQ Delta, LLC
13 US 8,238,412 B2	8/7/2012	TQ Delta, LLC
14 US 8,432,956 B2	4/30/2013	TQ Delta, LLC
15 US 7,451,379 B2	11/11/2008	TQ Delta, LLC
16 US 8,516,337 B2	8/20/2013	TQ Delta, LLC
17 US 7,979,778 B2	7/12/2011	TQ Delta, LLC
18 US 7,925,958 B2	4/12/2011	TQ Delta, LLC
19 US 8,462,835 B2	6/11/2013	TQ Delta, LLC



AO 120 (Rev. 08-10)

TO: <b>Mail Stop 8</b> <b>Director of the U.S. Patent and Trademark Office</b> P.O. Box 1450 Alexandria, VA 22313-1450	<b>REPORT ON THE                  FILING OR DETERMINATION OF AN                  ACTION REGARDING A PATENT OR                  TRADEMARK</b>
---	--

In Compliance with 35 U.S.C. § 290 and/or 15 U.S.C. § 1116 you are hereby advised that a court action has been filed in the U.S. District Court District of Delaware on the following

Trademarks or  Patents. (  the patent action involves 35 U.S.C. § 292.);

DOCKET NO.	DATE FILED 11/4/2013	U.S. DISTRICT COURT District of Delaware
PLAINTIFF TQ Delta, LLC		DEFENDANT Zhone Technologies, Inc.
PATENT OR TRADEMARK NO.	DATE OF PATENT OR TRADEMARK	HOLDER OF PATENT OR TRADEMARK
1 See Attached		
2		
3		
4		
5		

In the above—entitled case, the following patent(s)/ trademark(s) have been included:

DATE INCLUDED	INCLUDED BY <input type="checkbox"/> Amendment <input type="checkbox"/> Answer <input type="checkbox"/> Cross Bill <input type="checkbox"/> Other Pleading
PATENT OR TRADEMARK NO.	DATE OF PATENT OR TRADEMARK HOLDER OF PATENT OR TRADEMARK
1	
2	
3	
4	
5	

In the above—entitled case, the following decision has been rendered or judgement issued:

DECISION/JUDGEMENT
--------------------

CLERK	(BY) DEPUTY CLERK	DATE
-------	-------------------	------

Copy 1—Upon initiation of action, mail this copy to Director    Copy 3—Upon termination of action, mail this copy to Director  
 Copy 2—Upon filing document adding patent(s), mail this copy to Director    Copy 4—Case file copy

PATENT OR TRADEMARK NO.	DATE OF PATENT OR TRADEMARK	HOLDER OF PATENT OR TRADEMARK
1 US 8,090,008 B2	1/3/2012	TQ Delta, LLC
2 US 8,073,041 B1	12/6/2011	TQ Delta, LLC
3 US 7,292,627 B2	11/6/2007	TQ Delta, LLC
4 US 7,471,721 B2	12/30/2008	TQ Delta, LLC
5 US 8,218,610 B2	7/10/2012	TQ Delta, LLC
6. US 8,355,427 B2	1/15/2013	TQ Delta, LLC
7 US 7,453,881 B2	11/18/2008	TQ Delta, LLC
8 US 7,809,028 B2	10/5/2010	TQ Delta, LLC
9 US 7,978,706 B2	7/12/2011	TQ Delta, LLC
10 US 8,422,511 B2	4/16/2013	TQ Delta, LLC
11 US 7,796,705 B2	9/14/2010	TQ Delta, LLC
12 US 7,889,784 B2	2/15/2011	TQ Delta, LLC
13 US 7,835,430 B2	11/16/2010	TQ Delta, LLC
14 US 7,570,686 B2	8/4/2009	TQ Delta, LLC
15 US 8,238,412 B2	8/7/2012	TQ Delta, LLC
16 US 8,432,956 B2	4/30/2013	TQ Delta, LLC
17 US 7,451,379 B2	11/11/2008	TQ Delta, LLC
18 US 8,516,337 B2	8/20/2013	TQ Delta, LLC
19 US 7,979,778 B2	7/12/2011	TQ Delta, LLC
20 US 7,925,958 B2	4/12/2011	TQ Delta, LLC
21 US 8,462,835 B2	6/11/2013	TQ Delta, LLC
22 US 7,978,753 B2	7/12/2011	TQ Delta, LLC
23 US 6,445,730 B1	9/3/2002	TQ Delta, LLC
24 US 8,437,382 B2	5/7/2013	TQ Delta, LLC



UNITED STATES PATENT AND TRADEMARK OFFICE

UNITED STATES DEPARTMENT OF COMMERCE  
United States Patent and Trademark Office  
Address: COMMISSIONER FOR PATENTS  
P.O. Box 1450  
Alexandria, Virginia 22313-1450  
www.uspto.gov

APPLICATION NUMBER	FILING OR 371(C) DATE	FIRST NAMED APPLICANT	ATTY. DOCKET NO./TITLE
12/477,742	06/03/2009	David M. Krinsky	6936-2-CON-2-1

**CONFIRMATION NO. 8072**

**POA ACCEPTANCE LETTER**



OC000000057541371

62574  
Jason H. Vick  
Sheridan Ross, PC  
Suite # 1200  
1560 Broadway  
Denver, CO 80202

Date Mailed: 11/14/2012

**NOTICE OF ACCEPTANCE OF POWER OF ATTORNEY**

This is in response to the Power of Attorney filed 11/05/2012.

The Power of Attorney in this application is accepted. Correspondence in this application will be mailed to the above address as provided by 37 CFR 1.33.

/atesfai/

Office of Data Management, Application Assistance Unit (571) 272-4000, or (571) 272-4200, or 1-888-786-0101

Under the Paperwork Reduction Act of 1995, no persons are required to respond to a collection of information unless it displays a valid OMB control number.

**POWER OF ATTORNEY TO PROSECUTE APPLICATIONS BEFORE THE USPTO**

I hereby revoke all previous powers of attorney given in the application identified in the attached statement under 37 CFR 3.73(c).

I hereby appoint:

Practitioners associated with Customer Number: 62574

**OR**

Practitioner(s) named below (if more than ten patent practitioners are to be named, then a customer number must be used):

Name	Registration Number	Name	Registration Number

As attorney(s) or agent(s) to represent the undersigned before the United States Patent and Trademark Office (USPTO) in connection with any and all patent applications assigned only to the undersigned according to the USPTO assignment records or assignments documents attached to this form in accordance with 37 CFR 3.73(c).

Please change the correspondence address for the application identified in the attached statement under 37 CFR 3.73(c) to:

The address associated with Customer Number: 62574

**OR**

<input type="checkbox"/>	Firm or Individual Name			
	Address			
	City	State	Zip	
	Country			
	Telephone	Email		

Assignee Name and Address: TQ DELTA, LLC  
 805 Las Cimas Parkway, Suite 240  
 Austin, Texas 78746

**A copy of this form, together with a statement under 37 CFR 3.73(c) (Form PTO/AIA/96 or equivalent) is required to be filed in each application in which this form is used. The statement under 37 CFR 3.73(c) may be completed by one of the practitioners appointed in this form, and must identify the application in which this Power of Attorney is to be filed.**

**SIGNATURE of Assignee of Record**

The individual whose signature and title is supplied below is authorized to act on behalf of the assignee

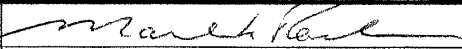
Signature		Date	10/4/12
Name	Mark K. Roche	Telephone	512-609-1810
Title	Managing Director		

This collection of information is required by 37 CFR 1.31, 1.32 and 1.33. The information is required to obtain or retain a benefit by the public which is to file (and by the USPTO to process) an application. Confidentiality is governed by 35 U.S.C. 122 and 37 CFR 1.11 and 1.14. This collection is estimated to take 3 minutes to complete, including gathering, preparing, and submitting the completed application form to the USPTO. Time will vary depending upon the individual case. Any comments on the amount of time you require to complete this form and/or suggestions for reducing this burden, should be sent to the Chief Information Officer, U.S. Patent and Trademark Office, U.S. Department of Commerce, P.O. Box 1450, Alexandria, VA 22313-1450. DO NOT SEND FEES OR COMPLETED FORMS TO THIS ADDRESS. SEND TO: Commissioner for Patents, P.O. Box 1450, Alexandria, VA 22313-1450.

If you need assistance in completing the form, call 1-800-PTO-9199 and select option 2.

## Electronic Acknowledgement Receipt

<b>EFS ID:</b>	14147944
<b>Application Number:</b>	12477742
<b>International Application Number:</b>	
<b>Confirmation Number:</b>	8072
<b>Title of Invention:</b>	MULTICARRIER MODULATION MESSAGING FOR FREQUENCY DOMAIN RECEIVED IDLE CHANNEL NOISE INFORMATION
<b>First Named Inventor/Applicant Name:</b>	David M. Krinsky
<b>Customer Number:</b>	62574
<b>Filer:</b>	Jason Vick/Joanne Vos
<b>Filer Authorized By:</b>	Jason Vick
<b>Attorney Docket Number:</b>	6936-2-CON-2-1
<b>Receipt Date:</b>	05-NOV-2012
<b>Filing Date:</b>	03-JUN-2009
<b>Time Stamp:</b>	14:07:31
<b>Application Type:</b>	Utility under 35 USC 111(a)

### Payment information:

Submitted with Payment	no
------------------------	----

### File Listing:

Document Number	Document Description	File Name	File Size(Bytes)/ Message Digest	Multi Part /.zip	Pages (if appl.)
1		EntityStatus_373c_w_POA.pdf	422411 53819026fd684a2c1bee4f2acc8de1ce2cb637ef	yes	4

<b>Multipart Description/PDF files in .zip description</b>		
<b>Document Description</b>	<b>Start</b>	<b>End</b>
Miscellaneous Incoming Letter	1	1
Assignee showing of ownership per 37 CFR 3.73.	2	3
Power of Attorney	4	4
<b>Warnings:</b>		
<b>Information:</b>		
<b>Total Files Size (in bytes):</b>	422411	
<p><b>This Acknowledgement Receipt evidences receipt on the noted date by the USPTO of the indicated documents, characterized by the applicant, and including page counts, where applicable. It serves as evidence of receipt similar to a Post Card, as described in MPEP 503.</b></p> <p><b><u>New Applications Under 35 U.S.C. 111</u></b>  <b>If a new application is being filed and the application includes the necessary components for a filing date (see 37 CFR 1.53(b)-(d) and MPEP 506), a Filing Receipt (37 CFR 1.54) will be issued in due course and the date shown on this Acknowledgement Receipt will establish the filing date of the application.</b></p> <p><b><u>National Stage of an International Application under 35 U.S.C. 371</u></b>  <b>If a timely submission to enter the national stage of an international application is compliant with the conditions of 35 U.S.C. 371 and other applicable requirements a Form PCT/DO/EO/903 indicating acceptance of the application as a national stage submission under 35 U.S.C. 371 will be issued in addition to the Filing Receipt, in due course.</b></p> <p><b><u>New International Application Filed with the USPTO as a Receiving Office</u></b>  <b>If a new international application is being filed and the international application includes the necessary components for an international filing date (see PCT Article 11 and MPEP 1810), a Notification of the International Application Number and of the International Filing Date (Form PCT/RO/105) will be issued in due course, subject to prescriptions concerning national security, and the date shown on this Acknowledgement Receipt will establish the international filing date of the application.</b></p>		

IN THE UNITED STATES PATENT AND TRADEMARK OFFICE

In Re the Application of: David M. Krinsky ) Patent No. 7,835,430  
Application No.: 12/477,742 ) Issued: November 16, 2010  
Filed: June 3, 2009 ) Examiner: TRAN, Khanh C.  
Atty. File No.: 6936-2-CON-2-1 ) Confirmation No.: 8072

For: MULTICARRIER MODULATION MESSAGING FOR FREQUENCY DOMAIN  
RECEIVED IDLE CHANNEL NOISE INFORMATION

**ASSERTION OF ENTITLEMENT TO SMALL ENTITY STATUS**

Commissioner for Patents  
P.O. Box 1450  
Alexandria, VA 22313-1450

Madam:

In accordance with MPEP §§ 509.02 and 509.03 AND 37 CFR 1.27, this document is being filed to inform the U.S. Patent Office of the change of status for the above-identified patent from large entity status to small entity status. All fees paid to date have been paid as large entity status. No fees have yet been paid as small entity status. Due to the sale of the referenced patent, the Applicant is now entitled to small entity status.

We respectfully request that small entity status be granted for the above-referenced patent application.

Please contact the undersigned if there are any questions regarding this notification.

Respectfully submitted,

SHERIDAN ROSS P.C.

Date: 5 Nov '12

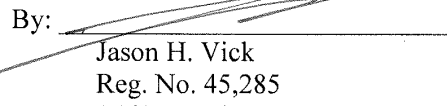
By:   
Jason H. Vick  
Reg. No. 45,285  
1560 Broadway, Suite 1200  
Denver, Colorado 80202  
Telephone: 303-863-9700

Under the Paperwork Reduction Act of 1995, no persons are required to respond to a collection of information unless it displays a valid OMB control number.

**STATEMENT UNDER 37 CFR 3.73(c)**

Applicant/Patent Owner: TQ DELTA, LLC

Application No./Patent No.: 7,835,430 Filed/Issue Date: November 16, 2010

Titled: MULTICARRIER MODULATION MESSAGING FOR FREQUENCY DOMAIN RECEIVED IDLE CHANNEL NOISE INFORMATION

TQ DELTA, LLC, a Corporation

(Name of Assignee)

(Type of Assignee, e.g., corporation, partnership, university, government agency, etc.)

states that, for the patent application/patent identified above, it is (choose **one** of options 1, 2, 3 or 4 below):

- 1.  The assignee of the entire right, title, and interest.
- 2.  An assignee of less than the entire right, title, and interest (check applicable box):
  - The extent (by percentage) of its ownership interest is \_\_\_\_\_%. Additional Statement(s) by the owners holding the balance of the interest **must be submitted** to account for 100% of the ownership interest.
  - There are unspecified percentages of ownership. The other parties, including inventors, who together own the entire right, title and interest are:

Additional Statement(s) by the owner(s) holding the balance of the interest **must be submitted** to account for the entire right, title, and interest.

- 3.  The assignee of an undivided interest in the entirety (a complete assignment from one of the joint inventors was made). The other parties, including inventors, who together own the entire right, title, and interest are:

Additional Statement(s) by the owner(s) holding the balance of the interest **must be submitted** to account for the entire right, title, and interest.

- 4.  The recipient, via a court proceeding or the like (e.g., bankruptcy, probate), of an undivided interest in the entirety (a complete transfer of ownership interest was made). The certified document(s) showing the transfer is attached.

The interest identified in option 1, 2 or 3 above (not option 4) is evidenced by either (choose **one** of options A or B below):

- A.  An assignment from the inventor(s) of the patent application/patent identified above. The assignment was recorded in the United States Patent and Trademark Office at Reel \_\_\_\_\_, Frame \_\_\_\_\_, or for which a copy thereof is attached.
- B.  A chain of title from the inventor(s), of the patent application/patent identified above, to the current assignee as follows:

1. From: David M. Krinsky and Robert Edmund Pizzano, Jr. To: AWARE, INC.

The document was recorded in the United States Patent and Trademark Office at Reel 012216, Frame 0842, or for which a copy thereof is attached.

2. From: AWARE, INC. To: TQ DELTA, LLC

The document was recorded in the United States Patent and Trademark Office at Reel 029154, Frame 0937, or for which a copy thereof is attached.

[Page 1 of 2]

This collection of information is required by 37 CFR 3.73(b). The information is required to obtain or retain a benefit by the public which is to file (and by the USPTO to process) an application. Confidentiality is governed by 35 U.S.C. 122 and 37 CFR 1.11 and 1.14. This collection is estimated to take 12 minutes to complete, including gathering, preparing, and submitting the completed application form to the USPTO. Time will vary depending upon the individual case. Any comments on the amount of time you require to complete this form and/or suggestions for reducing this burden, should be sent to the Chief Information Officer, U.S. Patent and Trademark Office, U.S. Department of Commerce, P.O. Box 1450, Alexandria, VA 22313-1450. DO NOT SEND FEES OR COMPLETED FORMS TO THIS ADDRESS. **SEND TO: Commissioner for Patents, P.O. Box 1450, Alexandria, VA 22313-1450.**

*If you need assistance in completing the form, call 1-800-PTO-9199 and select option 2.*



Under the Paperwork Reduction Act of 1995, no persons are required to respond to a collection of information unless it displays a valid OMB control number.

**STATEMENT UNDER 37 CFR 3.73(c)**

3. From: \_\_\_\_\_ To: \_\_\_\_\_

The document was recorded in the United States Patent and Trademark Office at  
Reel \_\_\_\_\_, Frame \_\_\_\_\_, or for which a copy thereof is attached.

4. From: \_\_\_\_\_ To: \_\_\_\_\_

The document was recorded in the United States Patent and Trademark Office at  
Reel \_\_\_\_\_, Frame \_\_\_\_\_, or for which a copy thereof is attached.

5. From: \_\_\_\_\_ To: \_\_\_\_\_

The document was recorded in the United States Patent and Trademark Office at  
Reel \_\_\_\_\_, Frame \_\_\_\_\_, or for which a copy thereof is attached.

6. From: \_\_\_\_\_ To: \_\_\_\_\_

The document was recorded in the United States Patent and Trademark Office at  
Reel \_\_\_\_\_, Frame \_\_\_\_\_, or for which a copy thereof is attached.

Additional documents in the chain of title are listed on a supplemental sheet(s).

As required by 37 CFR 3.73(c)(1)(i), the documentary evidence of the chain of title from the original owner to the assignee was, or concurrently is being, submitted for recordation pursuant to 37 CFR 3.11.

[NOTE: A separate copy (i.e., a true copy of the original assignment document(s)) must be submitted to Assignment Division in accordance with 37 CFR Part 3, to record the assignment in the records of the USPTO. See MPEP 302.08]

The undersigned (whose title is supplied below) is authorized to act on behalf of the assignee.

Signature \_\_\_\_\_

Jason H. Vick

Printed or Typed Name

5/24/12  
Date

45,285

Title or Registration Number



UNITED STATES PATENT AND TRADEMARK OFFICE

UNITED STATES DEPARTMENT OF COMMERCE
United States Patent and Trademark Office
Address: COMMISSIONER FOR PATENTS
P. O. Box 1450
Alexandria, Virginia 22313-1450
www.uspto.gov

Table with 5 columns: APPLICATION NO., ISSUE DATE, PATENT NO., ATTORNEY DOCKET NO., CONFIRMATION NO.
Row 1: 12/477,742, 11/16/2010, 7835430, 5550-2-CON-2-1, 8072

62574 7590 10/27/2010
Jason H. Vick
Sheridan Ross, PC
Suite # 1200
1560 Broadway
Denver, CO 80202

ISSUE NOTIFICATION

The projected patent number and issue date are specified above.

Determination of Patent Term Adjustment under 35 U.S.C. 154 (b)
(application filed on or after May 29, 2000)

The Patent Term Adjustment is 0 day(s). Any patent to issue from the above-identified application will include an indication of the adjustment on the front page.

If a Continued Prosecution Application (CPA) was filed in the above-identified application, the filing date that determines Patent Term Adjustment is the filing date of the most recent CPA.

Applicant will be able to obtain more detailed information by accessing the Patent Application Information Retrieval (PAIR) WEB site (http://pair.uspto.gov).

Any questions regarding the Patent Term Extension or Adjustment determination should be directed to the Office of Patent Legal Administration at (571)-272-7702. Questions relating to issue and publication fee payments should be directed to the Application Assistance Unit (AAU) of the Office of Data Management (ODM) at (571)-272-4200.

APPLICANT(s) (Please see PAIR WEB site http://pair.uspto.gov for additional applicants):

David M. Krinsky, Acton, MA;
Robert Edmund Pizzano Jr., Stoneham, MA;



UNITED STATES PATENT AND TRADEMARK OFFICE

UNITED STATES DEPARTMENT OF COMMERCE
United States Patent and Trademark Office
Address: COMMISSIONER FOR PATENTS
P.O. Box 1450
Alexandria, Virginia 22313-1450
www.uspto.gov

Table with columns: APPLICATION NO., FILING DATE, FIRST NAMED INVENTOR, ATTORNEY DOCKET NO., CONFIRMATION NO., EXAMINER, ART UNIT, PAPER NUMBER, NOTIFICATION DATE, DELIVERY MODE. Includes application details for David M. Krinsky and examiner information for TRAN, KHANH C.

Please find below and/or attached an Office communication concerning this application or proceeding.

The time period for reply, if any, is set in the attached communication.

Notice of the Office communication was sent electronically on above-indicated "Notification Date" to the following e-mail address(es):

jvick@sheridanross.com

<b>Supplemental Notice of Allowability</b>	<b>Application No.</b> 12/477,742	<b>Applicant(s)</b> KRINSKY ET AL.	
	<b>Examiner</b> KHANH C. TRAN	<b>Art Unit</b> 2611	

**-- The MAILING DATE of this communication appears on the cover sheet with the correspondence address--**

All claims being allowable, PROSECUTION ON THE MERITS IS (OR REMAINS) CLOSED in this application. If not included herewith (or previously mailed), a Notice of Allowance (PTOL-85) or other appropriate communication will be mailed in due course. **THIS NOTICE OF ALLOWABILITY IS NOT A GRANT OF PATENT RIGHTS.** This application is subject to withdrawal from issue at the initiative of the Office or upon petition by the applicant. See 37 CFR 1.313 and MPEP 1308.

1.  This communication is responsive to the IDS filed 9/27/2010.
2.  The allowed claim(s) is/are \_\_\_\_\_.
3.  Acknowledgment is made of a claim for foreign priority under 35 U.S.C. § 119(a)-(d) or (f).
  - a)  All    b)  Some\*    c)  None    of the:
    1.  Certified copies of the priority documents have been received.
    2.  Certified copies of the priority documents have been received in Application No. \_\_\_\_\_ .
    3.  Copies of the certified copies of the priority documents have been received in this national stage application from the International Bureau (PCT Rule 17.2(a)).

\* Certified copies not received: \_\_\_\_\_.

Applicant has THREE MONTHS FROM THE "MAILING DATE" of this communication to file a reply complying with the requirements noted below. Failure to timely comply will result in ABANDONMENT of this application.  
**THIS THREE-MONTH PERIOD IS NOT EXTENDABLE.**

4.  A SUBSTITUTE OATH OR DECLARATION must be submitted. Note the attached EXAMINER'S AMENDMENT or NOTICE OF INFORMAL PATENT APPLICATION (PTO-152) which gives reason(s) why the oath or declaration is deficient.
  5.  CORRECTED DRAWINGS ( as "replacement sheets") must be submitted.
    - (a)  including changes required by the Notice of Draftsperson's Patent Drawing Review ( PTO-948) attached
      - 1)  hereto or 2)  to Paper No./Mail Date \_\_\_\_\_.
    - (b)  including changes required by the attached Examiner's Amendment / Comment or in the Office action of Paper No./Mail Date \_\_\_\_\_.
- Identifying indicia such as the application number (see 37 CFR 1.84(c)) should be written on the drawings in the front (not the back) of each sheet. Replacement sheet(s) should be labeled as such in the header according to 37 CFR 1.121(d).**
6.  DEPOSIT OF and/or INFORMATION about the deposit of BIOLOGICAL MATERIAL must be submitted. Note the attached Examiner's comment regarding REQUIREMENT FOR THE DEPOSIT OF BIOLOGICAL MATERIAL.

**Attachment(s)**

- |  |   |
|--|---|
| 1. <input type="checkbox"/> Notice of References Cited (PTO-892)   | 5. <input type="checkbox"/> Notice of Informal Patent Application                       |
| 2. <input type="checkbox"/> Notice of Draftsperson's Patent Drawing Review (PTO-948)                               | 6. <input type="checkbox"/> Interview Summary (PTO-413),<br>Paper No./Mail Date _____ . |
| 3. <input checked="" type="checkbox"/> Information Disclosure Statements (PTO/SB/08),<br>Paper No./Mail Date _____ | 7. <input type="checkbox"/> Examiner's Amendment/Comment                                |
| 4. <input type="checkbox"/> Examiner's Comment Regarding Requirement for Deposit<br>of Biological Material         | 8. <input type="checkbox"/> Examiner's Statement of Reasons for Allowance               |
|  | 9. <input checked="" type="checkbox"/> Other <u>PTO-90C</u> .                           |

/KHANH C. TRAN/  
Primary Examiner, Art Unit 2611



UNITED STATES DEPARTMENT OF COMMERCE

**U.S. Patent and Trademark Office**

Address : COMMISSIONER FOR PATENTS  
P.O. Box 1450  
Alexandria, Virginia 22313-1450

APPLICATION NO./ CONTROL NO.	FILING DATE	FIRST NAMED INVENTOR / PATENT IN REEXAMINATION	ATTORNEY DOCKET NO.
12477742	6/3/2009	KRINSKY ET AL.	5550-2-CON-2-1

Jason H. Vick  
Sheridan Ross, PC  
Suite # 1200  
1560 Broadway  
Denver, CO 80202

**EXAMINER**

KHANH C.. TRAN

ART UNIT	PAPER
2611	20101008

DATE MAILED:

**Please find below and/or attached an Office communication concerning this application or proceeding.**

**Commissioner for Patents**

This communication is responsive to the IDS filed 9/27/2010.

/KHANH C. TRAN/  
Primary Examiner, Art Unit 2611

Substitute for form 1449A/PTO				<b>Complete if Known</b>	
<b>INFORMATION DISCLOSURE STATEMENT BY APPLICANT</b>				Application Number	12/477,742
				Filing Date	June 3, 2009
				First Named Inventor	David M. Krinsky
				Art Unit	2611
				Examiner Name	Khanh C. Tran
Sheet	1	of	1	Attorney Docket Number	5550-2-CON-2-1

U.S. PATENT DOCUMENTS					
Examiner Initials*	Cite No. <sup>1</sup>	Document Number Number-kind Code <sup>2 (if known)</sup>	Publication Date MM-DD-YYYY	Name of Patentee or Applicant of Cited Document	Pages, Columns, Lines, Where Relevant Passages or Relevant Figures Appear

FOREIGN PATENT DOCUMENTS						
Examiner Initials*	Cite No. <sup>1</sup>	Foreign Patent Document Country Code <sup>3</sup> ; Number <sup>4</sup> ; Kind Code <sup>5 (if known)</sup>	Publication Date MM-DD-YYYY	Name of Patentee or Applicant of Cited Document	Pages, Columns, Lines, Where Relevant Passages or Relevant Figures Appear	T <sup>6</sup>

OTHER ART (Including Author, Title, Date, Pertinent Pages, etc.)		
Examiner Initials*	Cite No. <sup>1</sup>	
/KCT/	1	Official Action for European Patent Application No. EP 06022008, mailed July 7, 2010, 2010 (Attorney's Ref. No. 5550-2-PEP5)
/KCT/	2	Official Action for Japanese Patent Application No. 2001-552611, mailed August 2, 2010 (Attorney's Ref. No. 5550-2-PJP)
/KCT/	3	Official Action for Japanese Patent Application No. 2008-191051, mailed July 26, 2010 (Attorney's Ref. No. 5550-2-PJP-DIV)
/KCT/	4	ITU-T g.992.1 "ASYMMETRIC DIGITAL SUBSCRIBER LINE (ADSL) TRANSCEIVERS" June 1999, p. 91-117, 125, 126, 131, 132

Examiner Signature	/Khanh Tran/ (09/29/2010)	Date Considered	09/29/2010
--------------------	---------------------------	-----------------	------------

\*EXAMINER: Initial if reference is considered, whether or not citation is in conformance and not considered. Include copy of this form with next communication to applicant.

ALL REFERENCES CONSIDERED EXCEPT WHERE LINED THROUGH. /KCT/



UNITED STATES PATENT AND TRADEMARK OFFICE

UNITED STATES DEPARTMENT OF COMMERCE
United States Patent and Trademark Office
Address: COMMISSIONER FOR PATENTS
P.O. Box 1450
Alexandria, Virginia 22313-1450
www.uspto.gov

Table with columns: APPLICATION NO., FILING DATE, FIRST NAMED INVENTOR, ATTORNEY DOCKET NO., CONFIRMATION NO., EXAMINER, ART UNIT, PAPER NUMBER, NOTIFICATION DATE, DELIVERY MODE. Includes application details for David M. Krinsky and examiner information for TRAN, KHANH C.

Please find below and/or attached an Office communication concerning this application or proceeding.

The time period for reply, if any, is set in the attached communication.

Notice of the Office communication was sent electronically on above-indicated "Notification Date" to the following e-mail address(es):

jvick@sheridanross.com

<b>Supplemental Notice of Allowability</b>	<b>Application No.</b> 12/477,742	<b>Applicant(s)</b> KRINSKY ET AL.	
	<b>Examiner</b> KHANH C. TRAN	<b>Art Unit</b> 2611	

**-- The MAILING DATE of this communication appears on the cover sheet with the correspondence address--**

All claims being allowable, PROSECUTION ON THE MERITS IS (OR REMAINS) CLOSED in this application. If not included herewith (or previously mailed), a Notice of Allowance (PTOL-85) or other appropriate communication will be mailed in due course. **THIS NOTICE OF ALLOWABILITY IS NOT A GRANT OF PATENT RIGHTS.** This application is subject to withdrawal from issue at the initiative of the Office or upon petition by the applicant. See 37 CFR 1.313 and MPEP 1308.

1.  This communication is responsive to the Amendment After Notice of Allowance and the IDS filed 9/27/2010.
2.  The allowed claim(s) is/are \_\_\_\_\_.
3.  Acknowledgment is made of a claim for foreign priority under 35 U.S.C. § 119(a)-(d) or (f).
  - a)  All   b)  Some\*   c)  None   of the:
    1.  Certified copies of the priority documents have been received.
    2.  Certified copies of the priority documents have been received in Application No. \_\_\_\_\_ .
    3.  Copies of the certified copies of the priority documents have been received in this national stage application from the International Bureau (PCT Rule 17.2(a)).

\* Certified copies not received: \_\_\_\_\_.

Applicant has THREE MONTHS FROM THE "MAILING DATE" of this communication to file a reply complying with the requirements noted below. Failure to timely comply will result in ABANDONMENT of this application.  
**THIS THREE-MONTH PERIOD IS NOT EXTENDABLE.**

4.  A SUBSTITUTE OATH OR DECLARATION must be submitted. Note the attached EXAMINER'S AMENDMENT or NOTICE OF INFORMAL PATENT APPLICATION (PTO-152) which gives reason(s) why the oath or declaration is deficient.
  5.  CORRECTED DRAWINGS ( as "replacement sheets") must be submitted.
    - (a)  including changes required by the Notice of Draftsperson's Patent Drawing Review ( PTO-948) attached
      - 1)  hereto or 2)  to Paper No./Mail Date \_\_\_\_\_.
    - (b)  including changes required by the attached Examiner's Amendment / Comment or in the Office action of Paper No./Mail Date \_\_\_\_\_.
- Identifying indicia such as the application number (see 37 CFR 1.84(c)) should be written on the drawings in the front (not the back) of each sheet. Replacement sheet(s) should be labeled as such in the header according to 37 CFR 1.121(d).**
6.  DEPOSIT OF and/or INFORMATION about the deposit of BIOLOGICAL MATERIAL must be submitted. Note the attached Examiner's comment regarding REQUIREMENT FOR THE DEPOSIT OF BIOLOGICAL MATERIAL.

**Attachment(s)**

- |   |  |
|---|--|
| <ol style="list-style-type: none"> <li>1. <input type="checkbox"/> Notice of References Cited (PTO-892)</li> <li>2. <input type="checkbox"/> Notice of Draftsperson's Patent Drawing Review (PTO-948)</li> <li>3. <input type="checkbox"/> Information Disclosure Statements (PTO/SB/08), Paper No./Mail Date _____</li> <li>4. <input type="checkbox"/> Examiner's Comment Regarding Requirement for Deposit of Biological Material</li> </ol> | <ol style="list-style-type: none"> <li>5. <input type="checkbox"/> Notice of Informal Patent Application</li> <li>6. <input type="checkbox"/> Interview Summary (PTO-413), Paper No./Mail Date _____ .</li> <li>7. <input type="checkbox"/> Examiner's Amendment/Comment</li> <li>8. <input type="checkbox"/> Examiner's Statement of Reasons for Allowance</li> <li>9. <input checked="" type="checkbox"/> Other <u>PTO-90C.</u></li> </ol> |
|---|--|

--	--





UNITED STATES DEPARTMENT OF COMMERCE

**U.S. Patent and Trademark Office**

Address : COMMISSIONER FOR PATENTS  
P.O. Box 1450  
Alexandria, Virginia 22313-1450

APPLICATION NO./ CONTROL NO.	FILING DATE	FIRST NAMED INVENTOR / PATENT IN REEXAMINATION	ATTORNEY DOCKET NO.
12477742	6/3/2009	KRINSKY ET AL.	5550-2-CON-2-1

Jason H. Vick  
Sheridan Ross, PC  
Suite # 1200  
1560 Broadway  
Denver, CO 80202

EXAMINER

KHANH C.. TRAN

ART UNIT	PAPER
2611	20100929

DATE MAILED:

**Please find below and/or attached an Office communication concerning this application or proceeding.**

Commissioner for Patents

This Communication is in response to the Amendment After Notice of Allowance (Rule 312) and the IDS filed 9/27/2010.

/KCT/

/KHANH C. TRAN/  
Primary Examiner, Art Unit 2611



UNITED STATES PATENT AND TRADEMARK OFFICE

UNITED STATES DEPARTMENT OF COMMERCE
United States Patent and Trademark Office
Address: COMMISSIONER FOR PATENTS
P.O. Box 1450
Alexandria, Virginia 22313-1450
www.uspto.gov

Table with 7 columns: APPLICATION NUMBER, FILING or 371(c) DATE, GRP ART UNIT, FIL FEE REC'D, ATTY. DOCKET NO, TOT CLAIMS, IND CLAIMS. Values: 12/477,742, 06/03/2009, 2611, 2050, 5550-2-CON-2-1, 3, 3

CONFIRMATION NO. 8072
CORRECTED FILING RECEIPT



62574
Jason H. Vick
Sheridan Ross, PC
Suite # 1200
1560 Broadway
Denver, CO 80202

Date Mailed: 10/05/2010

Receipt is acknowledged of this non-provisional patent application. The application will be taken up for examination in due course. Applicant will be notified as to the results of the examination. Any correspondence concerning the application must include the following identification information: the U.S. APPLICATION NUMBER, FILING DATE, NAME OF APPLICANT, and TITLE OF INVENTION. Fees transmitted by check or draft are subject to collection. Please verify the accuracy of the data presented on this receipt. If an error is noted on this Filing Receipt, please submit a written request for a Filing Receipt Correction. Please provide a copy of this Filing Receipt with the changes noted thereon. If you received a "Notice to File Missing Parts" for this application, please submit any corrections to this Filing Receipt with your reply to the Notice. When the USPTO processes the reply to the Notice, the USPTO will generate another Filing Receipt incorporating the requested corrections

Applicant(s)

David M. Krinsky, Acton, MA;
Robert Edmund Pizzano Jr., Stoneham, MA;

Assignment For Published Patent Application

AWARE, INC., Bedford, MA

Power of Attorney: The patent practitioners associated with Customer Number 62574

Domestic Priority data as claimed by applicant

This application is a CON of 10/619,691 07/16/2003 PAT 7,570,686 \*
which is a DIV of 09/755,173 01/08/2001 PAT 6,658,052
which claims benefit of 60/224,308 08/10/2000
and claims benefit of 60/174,865 01/07/2000 \*
(\*)Data provided by applicant is not consistent with PTO records.

Foreign Applications

If Required, Foreign Filing License Granted: 06/10/2009

The country code and number of your priority application, to be used for filing abroad under the Paris Convention, is US 12/477,742

Projected Publication Date: Not Applicable

Non-Publication Request: No

Early Publication Request: No

**Title**

MULTICARRIER MODULATION MESSAGING FOR FREQUENCY DOMAIN RECEIVED IDLE CHANNEL NOISE INFORMATION

**Preliminary Class**

375

**PROTECTING YOUR INVENTION OUTSIDE THE UNITED STATES**

Since the rights granted by a U.S. patent extend only throughout the territory of the United States and have no effect in a foreign country, an inventor who wishes patent protection in another country must apply for a patent in a specific country or in regional patent offices. Applicants may wish to consider the filing of an international application under the Patent Cooperation Treaty (PCT). An international (PCT) application generally has the same effect as a regular national patent application in each PCT-member country. The PCT process **simplifies** the filing of patent applications on the same invention in member countries, but **does not result** in a grant of "an international patent" and does not eliminate the need of applicants to file additional documents and fees in countries where patent protection is desired.

Almost every country has its own patent law, and a person desiring a patent in a particular country must make an application for patent in that country in accordance with its particular laws. Since the laws of many countries differ in various respects from the patent law of the United States, applicants are advised to seek guidance from specific foreign countries to ensure that patent rights are not lost prematurely.

Applicants also are advised that in the case of inventions made in the United States, the Director of the USPTO must issue a license before applicants can apply for a patent in a foreign country. The filing of a U.S. patent application serves as a request for a foreign filing license. The application's filing receipt contains further information and guidance as to the status of applicant's license for foreign filing.

Applicants may wish to consult the USPTO booklet, "General Information Concerning Patents" (specifically, the section entitled "Treaties and Foreign Patents") for more information on timeframes and deadlines for filing foreign patent applications. The guide is available either by contacting the USPTO Contact Center at 800-786-9199, or it can be viewed on the USPTO website at <http://www.uspto.gov/web/offices/pac/doc/general/index.html>.

For information on preventing theft of your intellectual property (patents, trademarks and copyrights), you may wish to consult the U.S. Government website, <http://www.stopfakes.gov>. Part of a Department of Commerce initiative, this website includes self-help "toolkits" giving innovators guidance on how to protect intellectual property in specific countries such as China, Korea and Mexico. For questions regarding patent enforcement issues, applicants may call the U.S. Government hotline at 1-866-999-HALT (1-866-999-4158).

**LICENSE FOR FOREIGN FILING UNDER**

**Title 35, United States Code, Section 184**

**Title 37, Code of Federal Regulations, 5.11 & 5.15**

**GRANTED**

The applicant has been granted a license under 35 U.S.C. 184, if the phrase "IF REQUIRED, FOREIGN FILING LICENSE GRANTED" followed by a date appears on this form. Such licenses are issued in all applications where

the conditions for issuance of a license have been met, regardless of whether or not a license may be required as set forth in 37 CFR 5.15. The scope and limitations of this license are set forth in 37 CFR 5.15(a) unless an earlier license has been issued under 37 CFR 5.15(b). The license is subject to revocation upon written notification. The date indicated is the effective date of the license, unless an earlier license of similar scope has been granted under 37 CFR 5.13 or 5.14.

This license is to be retained by the licensee and may be used at any time on or after the effective date thereof unless it is revoked. This license is automatically transferred to any related applications(s) filed under 37 CFR 1.53(d). This license is not retroactive.

The grant of a license does not in any way lessen the responsibility of a licensee for the security of the subject matter as imposed by any Government contract or the provisions of existing laws relating to espionage and the national security or the export of technical data. Licensees should apprise themselves of current regulations especially with respect to certain countries, of other agencies, particularly the Office of Defense Trade Controls, Department of State (with respect to Arms, Munitions and Implements of War (22 CFR 121-128)); the Bureau of Industry and Security, Department of Commerce (15 CFR parts 730-774); the Office of Foreign Assets Control, Department of Treasury (31 CFR Parts 500+) and the Department of Energy.

**NOT GRANTED**

No license under 35 U.S.C. 184 has been granted at this time, if the phrase "IF REQUIRED, FOREIGN FILING LICENSE GRANTED" DOES NOT appear on this form. Applicant may still petition for a license under 37 CFR 5.12, if a license is desired before the expiration of 6 months from the filing date of the application. If 6 months has lapsed from the filing date of this application and the licensee has not received any indication of a secrecy order under 35 U.S.C. 181, the licensee may foreign file the application pursuant to 37 CFR 5.15(b).



UNITED STATES PATENT AND TRADEMARK OFFICE

UNITED STATES DEPARTMENT OF COMMERCE  
 United States Patent and Trademark Office  
 Address: COMMISSIONER FOR PATENTS  
 P.O. Box 1450  
 Alexandria, Virginia 22313-1450  
 www.uspto.gov



Bib Data Sheet

CONFIRMATION NO. 8072

<b>SERIAL NUMBER</b> 12/477,742	<b>FILING OR 371(c) DATE</b> 06/03/2009 <b>RULE</b>	<b>CLASS</b> 375	<b>GROUP ART UNIT</b> 2611	<b>ATTORNEY DOCKET NO.</b> 5550-2-CON-2-1
------------------------------------	---	---------------------	-------------------------------	--

**APPLICANTS**  
 David M. Krinsky, Acton, MA;  
 Robert Edmund Pizzano Jr., Stoneham, MA;

**\*\* CONTINUING DATA \*\*\*\*\***  
 This application is a CON of 10/619,691 07/16/2003 PAT 7,570,686 \*  
 which is a DIV of 09/755,173 01/08/2001 PAT 6,658,052  
 which claims benefit of 60/224,308 08/10/2000  
 and claims benefit of 60/174,865 01/07/2000 \*  
 (\*)Data provided by applicant is not consistent with PTO records.

**\*\* FOREIGN APPLICATIONS \*\*\*\*\***

**IF REQUIRED, FOREIGN FILING LICENSE GRANTED**  
**\*\* 06/10/2009**

Foreign Priority claimed <input type="checkbox"/> yes <input type="checkbox"/> no	<b>STATE OR COUNTRY</b> MA	<b>SHEETS DRAWING</b> 2	<b>TOTAL CLAIMS</b> 3	<b>INDEPENDENT CLAIMS</b> 3	
35 USC 119 (a-d) conditions met <input type="checkbox"/> yes <input type="checkbox"/> no <input type="checkbox"/> Met after Allowance					
Verified and Acknowledged	Examiner's Signature	Initials			

**ADDRESS**  
 62574

**TITLE**  
 MULTICARRIER MODULATION MESSAGING FOR FREQUENCY DOMAIN RECEIVED IDLE CHANNEL NOISE INFORMATION

<b>FILING FEE RECEIVED</b> 2050	FEES: Authority has been given in Paper No. _____ to charge/credit DEPOSIT ACCOUNT No. _____ for following:	<input type="checkbox"/> All Fees
		<input type="checkbox"/> 1.16 Fees ( Filing )
		<input type="checkbox"/> 1.17 Fees ( Processing Ext. of time )
		<input type="checkbox"/> 1.18 Fees ( Issue )
		<input type="checkbox"/> Other _____
		<input type="checkbox"/> Credit



UNITED STATES PATENT AND TRADEMARK OFFICE

UNITED STATES DEPARTMENT OF COMMERCE  
 United States Patent and Trademark Office  
 Address: COMMISSIONER FOR PATENTS  
 P.O. Box 1450  
 Alexandria, Virginia 22313-1450  
 www.uspto.gov

BIB DATA SHEET

CONFIRMATION NO. 8072

<b>SERIAL NUMBER</b> 12/477,742	<b>FILING or 371(c) DATE</b> 06/03/2009 <b>RULE</b>	<b>CLASS</b> 375	<b>GROUP ART UNIT</b> 2611	<b>ATTORNEY DOCKET NO.</b> 5550-2-CON-2-1		
<b>APPLICANTS</b> David M. Krinsky, Acton, MA; Robert Edmund Pizzano Jr., Stoneham, MA; <b>** CONTINUING DATA *****</b> This application is a CON of 10/619,691 07/16/2003 PAT 7,570,686 * which is a DIV of 09/755,173 01/08/2001 PAT 6,658,052 which claims benefit of 60/224,308 08/10/2000 and claims benefit of 60/174,865 01/07/2000 * (*)Data provided by applicant is not consistent with PTO records. <b>** FOREIGN APPLICATIONS *****</b> <b>** IF REQUIRED, FOREIGN FILING LICENSE GRANTED **</b> 06/10/2009						
Foreign Priority claimed <input type="checkbox"/> Yes <input checked="" type="checkbox"/> No 35 USC 119(a-d) conditions met <input type="checkbox"/> Yes <input checked="" type="checkbox"/> No Verified and Acknowledged <u>/KHANH C TRAN/</u> Examiner's Signature		<input type="checkbox"/> Met after Allowance KCT Initials	<b>STATE OR COUNTRY</b> MA	<b>SHEETS DRAWINGS</b> 2	<b>TOTAL CLAIMS</b> 3	<b>INDEPENDENT CLAIMS</b> 3
<b>ADDRESS</b> Jason H. Vick Sheridan Ross, PC Suite # 1200 1560 Broadway Denver, CO 80202 UNITED STATES						
<b>TITLE</b> MULTICARRIER MODULATION MESSAGING FOR FREQUENCY DOMAIN RECEIVED IDLE CHANNEL NOISE INFORMATION						
<b>FILING FEE RECEIVED</b> 2050	FEES: Authority has been given in Paper No. _____ to charge/credit DEPOSIT ACCOUNT No. _____ for following:		<input type="checkbox"/> All Fees			
			<input type="checkbox"/> 1.16 Fees (Filing)			
			<input type="checkbox"/> 1.17 Fees (Processing Ext. of time)			
			<input type="checkbox"/> 1.18 Fees (Issue)			
			<input type="checkbox"/> Other _____			
		<input type="checkbox"/> Credit				

9-28-10

Substitute for form 1449A/PTO				<b>Complete if Known</b>	
<b>INFORMATION DISCLOSURE STATEMENT BY APPLICANT</b>				Application Number	12/477,742
				Filing Date	June 3, 2009
				First Named Inventor	David M. Krinsky
				Art Unit	2611
				Examiner Name	Khanh C. Tran
Sheet	1	of	1	Attorney Docket Number	5550-2-CON-2-1

U.S. PATENT DOCUMENTS					
Examiner Initials*	Cite No. <sup>1</sup>	Document Number Number-kind Code <sup>2</sup> (if known)	Publication Date MM-DD-YYYY	Name of Patentee of Applicant of Cited Document	Pages, Columns, Lines, Where Relevant Passages or Relevant Figures Appear

FOREIGN PATENT DOCUMENTS						
Examiner Initials*	Cite No. <sup>1</sup>	Foreign Patent Document Country Code <sup>3</sup> ; Number <sup>4</sup> ; Kind Code <sup>5</sup> (if known)	Publication Date MM-DD-YYYY	Name of Patentee or Applicant of Cited Document	Pages, Columns, Lines, Where Relevant Passages or Relevant Figures Appear	T <sup>6</sup>

OTHER ART (Including Author, Title, Date, Pertinent Pages, etc.)		
Examiner Initials*	Cite No. <sup>1</sup>	
	1	Official Action for European Patent Application No. EP 06022008, mailed July 7, 2010, 2010 (Attorney's Ref. No. 5550-2-PEP5)
	2	Official Action for Japanese Patent Application No. 2001-552611, mailed August 2, 2010 (Attorney's Ref. No. 5550-2-PJP)
	3	Official Action for Japanese Patent Application No. 2008-191051, mailed July 26, 2010 (Attorney's Ref. No. 5550-2-PJP-DIV)
	4	ITU-T g.992.1 "ASYMMETRIC DIGITAL SUBSCRIBER LINE (ADSL) TRANSCEIVERS" June 1999, p. 91-117, 125, 126, 131, 132

Examiner Signature		Date Considered	
--------------------	--	-----------------	--

\*EXAMINER: Initial if reference is considered, whether or not citation is in conformance and not considered. Include copy of this form with next communication to applicant.

## Electronic Patent Application Fee Transmittal

<b>Application Number:</b>	12477742			
<b>Filing Date:</b>	03-Jun-2009			
<b>Title of Invention:</b>	SYSTEM AND METHOD FOR ESTABLISHING A DIAGNOSTIC TRANSMISSION MODE AND COMMUNICATING OVER THE SAME			
<b>First Named Inventor/Applicant Name:</b>	David M. Krinsky			
<b>Filer:</b>	Jason Vick/Joanne Vos			
<b>Attorney Docket Number:</b>	5550-2-CON-2-1			
Filed as Large Entity				
<b>Utility under 35 USC 111(a) Filing Fees</b>				
Description	Fee Code	Quantity	Amount	Sub-Total in USD(\$)
<b>Basic Filing:</b>				
<b>Pages:</b>				
<b>Claims:</b>				
<b>Miscellaneous-Filing:</b>				
<b>Petition:</b>				
<b>Patent-Appeals-and-Interference:</b>				
<b>Post-Allowance-and-Post-Issuance:</b>				
<b>Extension-of-Time:</b>				



Description	Fee Code	Quantity	Amount	Sub-Total in USD(\$)
<b>Miscellaneous:</b>				
Submission- Information Disclosure Stmt	1806	1	180	180
<b>Total in USD (\$)</b>				<b>180</b>

## Electronic Acknowledgement Receipt

<b>EFS ID:</b>	8501239
<b>Application Number:</b>	12477742
<b>International Application Number:</b>	
<b>Confirmation Number:</b>	8072
<b>Title of Invention:</b>	SYSTEM AND METHOD FOR ESTABLISHING A DIAGNOSTIC TRANSMISSION MODE AND COMMUNICATING OVER THE SAME
<b>First Named Inventor/Applicant Name:</b>	David M. Krinsky
<b>Customer Number:</b>	62574
<b>Filer:</b>	Jason Vick/Joanne Vos
<b>Filer Authorized By:</b>	Jason Vick
<b>Attorney Docket Number:</b>	5550-2-CON-2-1
<b>Receipt Date:</b>	27-SEP-2010
<b>Filing Date:</b>	03-JUN-2009
<b>Time Stamp:</b>	11:49:03
<b>Application Type:</b>	Utility under 35 USC 111(a)

### Payment information:

Submitted with Payment	yes
Payment Type	Deposit Account
Payment was successfully received in RAM	\$ 180
RAM confirmation Number	9297
Deposit Account	191970
Authorized User	

The Director of the USPTO is hereby authorized to charge indicated fees and credit any overpayment as follows:

Charge any Additional Fees required under 37 C.F.R. Section 1.16 (National application filing, search, and examination fees)

Charge any Additional Fees required under 37 C.F.R. Section 1.17 (Patent application and reexamination processing fees)

Charge any Additional Fees required under 37 C.F.R. Section 1.19 (Document supply fees)

Charge any Additional Fees required under 37 C.F.R. Section 1.20 (Post Issuance fees)

Charge any Additional Fees required under 37 C.F.R. Section 1.21 (Miscellaneous fees and charges)

**File Listing:**

Document Number	Document Description	File Name	File Size(Bytes)/ Message Digest	Multi Part /.zip	Pages (if appl.)
1		IDS_03.pdf	348110 a0b458b5c5f5dcfc3ea7f53feca3f1bfd3bf7ef	yes	4
<b>Multipart Description/PDF files in .zip description</b>					
	<b>Document Description</b>		<b>Start</b>		<b>End</b>
	Transmittal Letter		1		3
	Information Disclosure Statement (IDS) Filed (SB/08)		4		4
<b>Warnings:</b>					
<b>Information:</b>					
2	NPL Documents	5550-2-PEP-5_OA_7-7-2010.pdf	201750 75445cd31ff7e634d4b646b759e8ed0ca88f17e	no	7
<b>Warnings:</b>					
<b>Information:</b>					
3	NPL Documents	5550-2-PJP_OA_8_2_10.pdf	119171 d48aa9e15fe6a3fce79950ff95961315332bf56c	no	6
<b>Warnings:</b>					
<b>Information:</b>					
4	NPL Documents	5550-2-PJP-DIV_OA_7-26-10.pdf	98046 82fd899db7ff646954b8fc12899a361483450913	no	5
<b>Warnings:</b>					
<b>Information:</b>					
5	NPL Documents	ITU_T_Asymmetric_Digital_Subscriber_Line_ADSL_Transceivers.pdf	1967150 114bf28704d430ffe3ad61ee800b0b4afb97099e	no	34
<b>Warnings:</b>					
<b>Information:</b>					
6	Fee Worksheet (PTO-875)	fee-info.pdf	30607 46cac37d3c05ef0745c0fb5cef9a65677b9c1f96	no	2
<b>Warnings:</b>					
<b>Information:</b>					
<b>Total Files Size (in bytes):</b>			2764834		

This Acknowledgement Receipt evidences receipt on the noted date by the USPTO of the indicated documents, characterized by the applicant, and including page counts, where applicable. It serves as evidence of receipt similar to a Post Card, as described in MPEP 503.

**New Applications Under 35 U.S.C. 111**

If a new application is being filed and the application includes the necessary components for a filing date (see 37 CFR 1.53(b)-(d) and MPEP 506), a Filing Receipt (37 CFR 1.54) will be issued in due course and the date shown on this Acknowledgement Receipt will establish the filing date of the application.

**National Stage of an International Application under 35 U.S.C. 371**

If a timely submission to enter the national stage of an international application is compliant with the conditions of 35 U.S.C. 371 and other applicable requirements a Form PCT/DO/EO/903 indicating acceptance of the application as a national stage submission under 35 U.S.C. 371 will be issued in addition to the Filing Receipt, in due course.

**New International Application Filed with the USPTO as a Receiving Office**

If a new international application is being filed and the international application includes the necessary components for an international filing date (see PCT Article 11 and MPEP 1810), a Notification of the International Application Number and of the International Filing Date (Form PCT/RO/105) will be issued in due course, subject to prescriptions concerning national security, and the date shown on this Acknowledgement Receipt will establish the international filing date of the application.

IN THE UNITED STATES PATENT AND TRADEMARK OFFICE

In Re the Application of: ) Group Art Unit: 2611  
David M. Krinsky ) Confirmation No.: 8072  
Serial No.: 12/477,742 ) Examiner: Khanh C. Tran  
Filed: June 3, 2009 )  
Atty. File No.: 5550-2-CON-2-1 ) INFORMATION DISCLOSURE  
Entitled: "Multicarrier Modulation Messaging for ) STATEMENT  
Frequency Domain Received Idle Channel Noise )  
Information" ) Electronically Submitted

Commissioner for Patents  
P.O. Box 1450  
Alexandria, VA 22313-1450

Dear Sir:

The references cited on attached Form PTO-1449 are being called to the attention of the Examiner.

- Copies of the cited non-patent and/or foreign references are enclosed herewith.
- Copies of the cited U.S. patents and/or patent applications are enclosed herewith.
- Copies of the cited U.S. patents/patent application publications are not enclosed in accordance with 37 C.F.R. § 1.98(a).
- Copies of the cited references are not enclosed, in accordance with 37 C.F.R. § 1.98(d), because the references were cited by or submitted to the U.S. Patent and Trademark Office in prior application Serial No. \_\_\_\_\_ filed \_\_\_\_\_, which is relied upon for an earlier filing date under 35 U.S.C. § 120.
- To the best of applicants' belief, the pertinence of the foreign-language references are believed to be summarized in the attached English abstracts and in the figures, although applicants do not necessarily vouch for the accuracy of the translation.
- Examiner's attention is drawn to the following related applications:
  - Serial No. \_\_\_\_\_ filed \_\_\_\_\_ (Attorney's Ref. No.)
  - Serial No. \_\_\_\_\_ filed \_\_\_\_\_ (Attorney's Ref. No.)
- Other: \_\_\_\_\_

Submission of the above information is not intended as an admission that any item is citable under the statutes or rules to support a rejection, that any item disclosed

represents analogous art, or that those skilled in the art would refer to or recognize the pertinence of any reference without the benefit of hindsight, nor should an inference be drawn as to the pertinence of the references based on the order in which they are presented. Submission of this statement should not be taken as an indication that a search has been conducted, or that no better art exists.

It is respectfully requested that the cited information be expressly considered during the prosecution of this application and the references made of record therein.

**FEES**

<input type="checkbox"/>	<p><b>37 CFR 1.97(b):</b> No fee is believed due in connection with this submission, because the information disclosure statement submitted herewith is satisfied by one of the following conditions ("X" indicates satisfaction):</p> <p><input type="checkbox"/> Within three months of the filing date of a national application other than a continued prosecution application under 37 CFR 1.53(d), or</p> <p><input type="checkbox"/> Within three months of the date of entry into the national stage of an international application as set forth in 37 CFR 1.491 or</p> <p><input type="checkbox"/> Before the mailing date of a first Office Action on the merits, or</p> <p><input type="checkbox"/> Before the mailing of a first Office action after the filing of a request for continued examination under 37 CFR 1.114.</p> <p>Although no fee is believed due, if any fee is deemed due in connection with this submission, please charge such fee to Deposit Account 19-1970.</p>
<input type="checkbox"/>	<p><b>37 CFR 1.97(c):</b> The information disclosure statement transmitted herewith is being filed after all the above conditions (37 CFR 1.97(b)), but before the mailing date of one of the following conditions:</p> <p>(1) a final action under 37 C.F.R. 1.113 or</p> <p>(2) a notice of allowance under 37 C.F.R. 1.311, or</p> <p>(3) an action that otherwise closes prosecution in the application.</p> <p>This Information Disclosure Statement is accompanied by:</p> <p><input type="checkbox"/> A Certification (below) as specified by 37 C.F.R. 1.97(e). Although no fee is believed due, if any fee is deemed due in connection with this submission, please charge such fee to Deposit Account 19-1970.</p> <p style="text-align: center;">OR</p> <p><input type="checkbox"/> Please charge Deposit Account 19-1970 in the amount of \$180.00 for the fee set forth in 37 C.F.R. 1.17(p) for submission of an information disclosure statement. Please credit any overpayment or charge any underpayment to Deposit Account 19-1970.</p>
<input checked="" type="checkbox"/>	<p><b>37 CFR 1.97(d):</b> This Information Disclosure Statement is being submitted after the period specified in 37 CFR 1.97(c).</p> <p><input checked="" type="checkbox"/> This information Disclosure Statement includes a Certification (below) as specified by 37 C.F.R. 1.97(e)</p> <p style="text-align: center;">AND</p> <p><input checked="" type="checkbox"/> Applicants hereby requests consideration of the reference(s) disclosed herein. Please charge Deposit Account 19-1970 in the amount of \$180.00 under 37 C.F.R. 1.17(p). Please credit any overpayment or charge any underpayment to Deposit Account 19-1970. Election to pay the fee should not be taken as an indication that applicant(s) cannot execute a certification.</p>

**Certification (37 C.F.R. 1.97(e))**  
(Applicable only if checked)

- The undersigned certifies that:
- Each item of information contained in this information disclosure statement was first cited in any communication from a foreign patent office in a counterpart foreign application not more than three months prior to the filing of this statement. 37 C.F.R. 1.97(e)(1).
  - A copy of the communication from the foreign patent office is enclosed.

OR

- No item of information contained in this information disclosure statement was cited in a communication from a foreign patent office in a counterpart foreign application, and, to the knowledge of the undersigned after making reasonable inquiry, no item of information contained in this Information Disclosure Statement was known to any individual designated in 37 C.F.R. 1.56(c) more than three months prior to the filing of this statement. 37 C.F.R. 1.97(e)(2).

Respectfully submitted,

SHERIDAN ROSS P.C.

By: \_\_\_\_\_

Jason H. Vick  
Registration No. 45,285  
1560 Broadway, Suite 1200  
Denver, Colorado 80202-5141  
(303) 863-9700

Date: 22 Sept 11

**PART B - FEE(S) TRANSMITTAL**

**Complete and send this form, together with applicable fee(s), to: Mail Mail Stop ISSUE FEE  
 Commissioner for Patents  
 P.O. Box 1450  
 Alexandria, Virginia 22313-1450  
 or Fax (571)-273-2885**

**INSTRUCTIONS:** This form should be used for transmitting the ISSUE FEE and PUBLICATION FEE (if required). Blocks 1 through 5 should be completed where appropriate. All further correspondence including the Patent, advance orders and notification of maintenance fees will be mailed to the current correspondence address as indicated unless corrected below or directed otherwise in Block 1, by (a) specifying a new correspondence address; and/or (b) indicating a separate "FEE ADDRESS" for maintenance fee notifications.

CURRENT CORRESPONDENCE ADDRESS (Note: Use Block 1 for any change of address)

62574                      7590                      09/07/2010

**Jason H. Vick**  
**Sheridan Ross, PC**  
 Suite # 1200  
 1560 Broadway  
 Denver, CO 80202

Note: A certificate of mailing can only be used for domestic mailings of the Fee(s) Transmittal. This certificate cannot be used for any other accompanying papers. Each additional paper, such as an assignment or formal drawing, must have its own certificate of mailing or transmission.

**Certificate of Mailing or Transmission**

I hereby certify that this Fee(s) Transmittal is being deposited with the United States Postal Service with sufficient postage for first class mail in an envelope addressed to the Mail Stop ISSUE FEE address above, or being facsimile transmitted to the USPTO (571) 273-2885, on the date indicated below.

(Depositor's name)
(Signature)
(Date)

APPLICATION NO.	FILING DATE	FIRST NAMED INVENTOR	ATTORNEY DOCKET NO.	CONFIRMATION NO.
12/477,742	06/03/2009	David M. Krinsky	5550-2-CON-2-1	8072

TITLE OF INVENTION: SYSTEM AND METHOD FOR ESTABLISHING A DIAGNOSTIC TRANSMISSION MODE AND COMMUNICATING OVER THE SAME

APPLN. TYPE	SMALL ENTITY	ISSUE FEE DUE	PUBLICATION FEE DUE	PREV. PAID ISSUE FEE	TOTAL FEE(S) DUE	DATE DUE
nonprovisional	NO	\$1510	\$300	\$0	\$1810	12/07/2010

EXAMINER	ART UNIT	CLASS-SUBCLASS
TRAN, KHANH C	2611	375-222000

1. Change of correspondence address or indication of "Fee Address" (37 CFR 1.363).  
 Change of correspondence address (or Change of Correspondence Address form PTO/SB/122) attached.  
 "Fee Address" indication (or "Fee Address" Indication form PTO/SB/47; Rev 03-02 or more recent) attached. Use of a Customer Number is required.
2. For printing on the patent front page, list  
 (1) the names of up to 3 registered patent attorneys or agents OR, alternatively,  
 (2) the name of a single firm (having as a member a registered attorney or agent) and the names of up to 2 registered patent attorneys or agents. If no name is listed, no name will be printed.
1. Jason H. Vick  
 2. Sheridan Ross, P.C.  
 3. \_\_\_\_\_

3. ASSIGNEE NAME AND RESIDENCE DATA TO BE PRINTED ON THE PATENT (print or type)  
 PLEASE NOTE: Unless an assignee is identified below, no assignee data will appear on the patent. If an assignee is identified below, the document has been filed for recordation as set forth in 37 CFR 3.11. Completion of this form is NOT a substitute for filing an assignment.

(A) NAME OF ASSIGNEE    (B) RESIDENCE: (CITY AND STATE OR COUNTRY)  
**Aware, Inc.**    **Bedford, MA**

Please check the appropriate assignee category or categories (will not be printed on the patent):    Individual    Corporation or other private group entity    Government

- 4a. The following fee(s) are submitted:  
 Issue Fee  
 Publication Fee (No small entity discount permitted)  
 Advance Order - # of Copies \_\_\_\_\_
- 4b. Payment of Fee(s): (Please first reapply any previously paid issue fee shown above)  
 A check is enclosed.  
 Payment by credit card. Form PTO-2038 is attached.  
 The Director is hereby authorized to charge the required fee(s), any deficiency, or credit any overpayment, to Deposit Account Number 191970 (enclose an extra copy of this form).

5. Change in Entity Status (from status indicated above)  
 a. Applicant claims SMALL ENTITY status. See 37 CFR 1.27.    b. Applicant is no longer claiming SMALL ENTITY status. See 37 CFR 1.27(g)(2).

NOTE: The Issue Fee and Publication Fee (if required) will not be accepted from anyone other than the applicant; a registered attorney or agent; or the assignee or other party in interest as shown by the records of the United States Patent and Trademark Office.

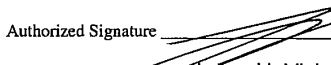
Authorized Signature     Date 27 Sept 10  
 Typed or printed name Jason H. Vick    Registration No. 45,285

This collection of information is required by 37 CFR 1.311. The information is required to obtain or retain a benefit by the public which is to file (and by the USPTO to process) an application. Confidentiality is governed by 35 U.S.C. 122 and 37 CFR 1.14. This collection is estimated to take 12 minutes to complete, including gathering, preparing, and submitting the completed application form to the USPTO. Time will vary depending upon the individual case. Any comments on the amount of time you require to complete this form and/or suggestions for reducing this burden, should be sent to the Chief Information Officer, U.S. Patent and Trademark Office, U.S. Department of Commerce, P.O. Box 1450, Alexandria, Virginia 22313-1450. DO NOT SEND FEES OR COMPLETED FORMS TO THIS ADDRESS. SEND TO: Commissioner for Patents, P.O. Box 1450, Alexandria, Virginia 22313-1450.

Under the Paperwork Reduction Act of 1995, no persons are required to respond to a collection of information unless it displays a valid OMB control number.



IN THE UNITED STATES PATENT AND TRADEMARK OFFICE

In Re the Application of: David M. Krinsky	)	Group Art Unit: 2611
	)	
Application No.: 12/477,742	)	Examiner: TRAN, Khanh C.
	)	
Filed: June 3, 2009	)	Confirmation No.: 8072
	)	
Atty. File No.: 5550-2-CON-2-1	)	
	)	

For: MULTICARRIER MODULATION MESSAGING FOR FREQUENCY DOMAIN  
RECEIVED IDLE CHANNEL NOISE INFORMATION

**COMMENTS ON STATEMENT OF REASONS FOR ALLOWANCE**

Commissioner for Patents  
P.O. Box 1450  
Alexandria, VA 22313

Sir:

Applicant submits this Comments on Statement of Reasons for Allowance to address further the Notice of Allowability ("Notice") having a mailing date of September 7, 2010.

In the Notice, the Examiner's stated reasons for allowance were that:

The instant Application is directed to a transceiver capable of transmitting and receiving, a non-transitory computer-readable information storage media having stored thereon instructions that, if executed, cause a transceiver to perform a method of transmitting and receiving a combination of uniquely distinct features "the message comprises one or more data variables that represent the test information, wherein bits in the message are modulated onto DMT symbols using Quadrature Amplitude Modulation (QAM) with more than 1 bit per sub-channel and wherein at least one data variable of the one or more data variables comprises an array representing frequency domain received idle channel noise information".

Based on the Notice, the patentability of all other independent and dependent claims is assumed to be based upon the elements as set forth in such claims and that such claims meet all criteria for patentability under §101, §102, §103 and §112.

As is clear from MPEP 1302.14,

“The statement [of reasons for allowance] is not intended to necessarily state all the reasons for allowance or all the details why claims are allowed and should not be written to specifically or impliedly state that all the reasons for allowance are set forth.”

While the stated Reasons for Allowance may be a stated reason for allowing some independent claims, Applicant submits that some independent claims have a different reason for allowance and that some independent claims have other reasons for allowance.

Specifically, the prior art fails to teach the specific combination of features as recited in the independent claims 47-52.

Although the Applicant believes that no fees are due for filing this Comments on Statement of Reasons for Allowance, please charge any fees deemed necessary to Deposit Account No. 19-1970.

Respectfully submitted,

SHERIDAN ROSS P.C.

Date: 27 Sept 11

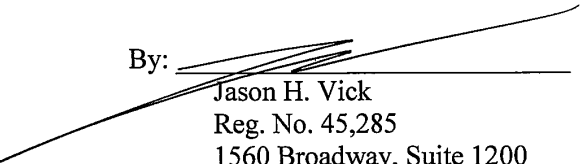
By: 

Jason H. Vick  
Reg. No. 45,285  
1560 Broadway, Suite 1200  
Denver, Colorado 80202  
Telephone: 303-863-9700

IN THE UNITED STATES PATENT AND TRADEMARK OFFICE

In Re the Application of: David M. Krinsky	)	Group Art Unit: 2611
	)	
Application No.: 12/477,742	)	Examiner: TRAN, Khanh C.
	)	
Filed: June 3, 2009	)	Confirmation No.: 8072
	)	
Atty. File No.: 5550-2-CON-2-1	)	
	)	

For: MULTICARRIER MODULATION MESSAGING FOR FREQUENCY DOMAIN  
RECEIVED IDLE CHANNEL NOISE INFORMATION

**AMENDMENT AFTER ALLOWANCE UNDER**  
**37 C.F.R. 1.312**

Commissioner for Patents  
P.O. Box 1450  
Alexandria, VA 22313-1450

Sir:

Applicants submit this Amendment After Allowance pursuant to 37 C.F.R. 1.312 in response to the Notice of Allowance having a mailing date of September 7, 2010. While Applicants believe that no fees are due with the filing of this response, the undersigned hereby authorizes the charge of any fees deemed necessary to Deposit Account No. 19-1970.

An amendment may be entered after the mailing of a Notice of Allowance but prior to payment of the issue fee upon recommendation of the primary Examiner. Therefore, it is respectfully requested that the above-referenced application be amended as follows:

**Amendments to the Specification** begin on page 2 of this paper.

**Remarks** begin on page 3 of this paper.

AMENDMENTS TO THE SPECIFICATION

**In the Title:**

Please amend the title to read as follows:

~~System and Method for Establishing A Diagnostic Transmission Mode and Communicating~~  
~~Over the Same Multicarrier Modulation Messaging For Frequency Domain Received Idle~~  
Channel Noise Information

**REMARKS**

The amendment to the specification displayed herein amends the title. No new matter is believed to be introduced by this amendment.

The Commissioner is hereby authorized to charge to deposit account number 19-1970 any fees under 37 CFR § 1.16 and 1.17 that may be required by this paper and to credit any overpayment to that Account. If any extension of time is required in connection with the filing of this paper and has not been separately requested, such extension is hereby petitioned.

Respectfully submitted,

SHERIDAN ROSS P.C.

Date: 27 Sept 16

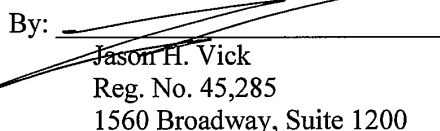
By:   
Jason H. Vick  
Reg. No. 45,285  
1560 Broadway, Suite 1200  
Denver, Colorado 80202  
Telephone: 303-863-9700

## Electronic Patent Application Fee Transmittal

<b>Application Number:</b>	12477742
<b>Filing Date:</b>	03-Jun-2009
<b>Title of Invention:</b>	SYSTEM AND METHOD FOR ESTABLISHING A DIAGNOSTIC TRANSMISSION MODE AND COMMUNICATING OVER THE SAME
<b>First Named Inventor/Applicant Name:</b>	David M. Krinsky
<b>Filer:</b>	Jason Vick/Joanne Vos
<b>Attorney Docket Number:</b>	5550-2-CON-2-1

Filed as Large Entity

### Utility under 35 USC 111(a) Filing Fees

Description	Fee Code	Quantity	Amount	Sub-Total in USD(\$)
<b>Basic Filing:</b>				
<b>Pages:</b>				
<b>Claims:</b>				
<b>Miscellaneous-Filing:</b>				
<b>Petition:</b>				
<b>Patent-Appeals-and-Interference:</b>				
<b>Post-Allowance-and-Post-Issuance:</b>				
Utility Appl issue fee	1501	1	1510	1510
Publ. Fee- early, voluntary, or normal	1504	1	300	300

Description	Fee Code	Quantity	Amount	Sub-Total in USD(\$)
<b>Extension-of-Time:</b>				
<b>Miscellaneous:</b>				
<b>Total in USD (\$)</b>				<b>1810</b>

## Electronic Acknowledgement Receipt

<b>EFS ID:</b>	8501454
<b>Application Number:</b>	12477742
<b>International Application Number:</b>	
<b>Confirmation Number:</b>	8072
<b>Title of Invention:</b>	SYSTEM AND METHOD FOR ESTABLISHING A DIAGNOSTIC TRANSMISSION MODE AND COMMUNICATING OVER THE SAME
<b>First Named Inventor/Applicant Name:</b>	David M. Krinsky
<b>Customer Number:</b>	62574
<b>Filer:</b>	Jason Vick/Joanne Vos
<b>Filer Authorized By:</b>	Jason Vick
<b>Attorney Docket Number:</b>	5550-2-CON-2-1
<b>Receipt Date:</b>	27-SEP-2010
<b>Filing Date:</b>	03-JUN-2009
<b>Time Stamp:</b>	12:05:22
<b>Application Type:</b>	Utility under 35 USC 111(a)

### Payment information:

Submitted with Payment	yes
Payment Type	Deposit Account
Payment was successfully received in RAM	\$ 1810
RAM confirmation Number	9501
Deposit Account	191970
Authorized User	

The Director of the USPTO is hereby authorized to charge indicated fees and credit any overpayment as follows:

Charge any Additional Fees required under 37 C.F.R. Section 1.16 (National application filing, search, and examination fees)

Charge any Additional Fees required under 37 C.F.R. Section 1.17 (Patent application and reexamination processing fees)



Charge any Additional Fees required under 37 C.F.R. Section 1.19 (Document supply fees)  
 Charge any Additional Fees required under 37 C.F.R. Section 1.20 (Post Issuance fees)  
 Charge any Additional Fees required under 37 C.F.R. Section 1.21 (Miscellaneous fees and charges)

**File Listing:**

Document Number	Document Description	File Name	File Size(Bytes)/ Message Digest	Multi Part /.zip	Pages (if appl.)
1		Issue_Fee_Transmittal.pdf	450772 ab5c4ea75718a36980a0ea3bdc00bf4bd8a293b	yes	6

Multipart Description/PDF files in .zip description			
Document Description	Start	End	
Issue Fee Payment (PTO-85B)	1	1	
Post Allowance Communication - Incoming	2	3	
Amendment after Notice of Allowance (Rule 312)	4	6	

**Warnings:**

**Information:**

2	Fee Worksheet (PTO-875)	fee-info.pdf	32042 7ba04ce095bc1ba39e760dd5814a99623f867785	no	2
---	-------------------------	--------------	---	----	---

**Warnings:**

**Information:**

<b>Total Files Size (in bytes):</b>	482814
-------------------------------------	--------

This Acknowledgement Receipt evidences receipt on the noted date by the USPTO of the indicated documents, characterized by the applicant, and including page counts, where applicable. It serves as evidence of receipt similar to a Post Card, as described in MPEP 503.

**New Applications Under 35 U.S.C. 111**

If a new application is being filed and the application includes the necessary components for a filing date (see 37 CFR 1.53(b)-(d) and MPEP 506), a Filing Receipt (37 CFR 1.54) will be issued in due course and the date shown on this Acknowledgement Receipt will establish the filing date of the application.

**National Stage of an International Application under 35 U.S.C. 371**

If a timely submission to enter the national stage of an international application is compliant with the conditions of 35 U.S.C. 371 and other applicable requirements a Form PCT/DO/EO/903 indicating acceptance of the application as a national stage submission under 35 U.S.C. 371 will be issued in addition to the Filing Receipt, in due course.

**New International Application Filed with the USPTO as a Receiving Office**

If a new international application is being filed and the international application includes the necessary components for an international filing date (see PCT Article 11 and MPEP 1810), a Notification of the International Application Number and of the International Filing Date (Form PCT/RO/105) will be issued in due course, subject to prescriptions concerning national security, and the date shown on this Acknowledgement Receipt will establish the international filing date of the application.



UNITED STATES PATENT AND TRADEMARK OFFICE

UNITED STATES DEPARTMENT OF COMMERCE
United States Patent and Trademark Office
Address: COMMISSIONER FOR PATENTS
P.O. Box 1450
Alexandria, Virginia 22313-1450
www.uspto.gov

NOTICE OF ALLOWANCE AND FEE(S) DUE

62574 7590 09/07/2010
Jason H. Vick
Sheridan Ross, PC
Suite # 1200
1560 Broadway
Denver, CO 80202

EXAMINER
TRAN, KHANH C
ART UNIT PAPER NUMBER
2611
DATE MAILED: 09/07/2010

Table with 5 columns: APPLICATION NO., FILING DATE, FIRST NAMED INVENTOR, ATTORNEY DOCKET NO., CONFIRMATION NO.
12/477,742 06/03/2009 David M. Krinsky 5550-2-CON-2-1 8072

TITLE OF INVENTION: SYSTEM AND METHOD FOR ESTABLISHING A DIAGNOSTIC TRANSMISSION MODE AND COMMUNICATING OVER THE SAME

Table with 7 columns: APPLN. TYPE, SMALL ENTITY, ISSUE FEE DUE, PUBLICATION FEE DUE, PREV. PAID ISSUE FEE, TOTAL FEE(S) DUE, DATE DUE
nonprovisional NO \$1510 \$300 \$0 \$1810 12/07/2010

THE APPLICATION IDENTIFIED ABOVE HAS BEEN EXAMINED AND IS ALLOWED FOR ISSUANCE AS A PATENT. PROSECUTION ON THE MERITS IS CLOSED. THIS NOTICE OF ALLOWANCE IS NOT A GRANT OF PATENT RIGHTS. THIS APPLICATION IS SUBJECT TO WITHDRAWAL FROM ISSUE AT THE INITIATIVE OF THE OFFICE OR UPON PETITION BY THE APPLICANT. SEE 37 CFR 1.313 AND MPEP 1308.

THE ISSUE FEE AND PUBLICATION FEE (IF REQUIRED) MUST BE PAID WITHIN THREE MONTHS FROM THE MAILING DATE OF THIS NOTICE OR THIS APPLICATION SHALL BE REGARDED AS ABANDONED. THIS STATUTORY PERIOD CANNOT BE EXTENDED. SEE 35 U.S.C. 151. THE ISSUE FEE DUE INDICATED ABOVE DOES NOT REFLECT A CREDIT FOR ANY PREVIOUSLY PAID ISSUE FEE IN THIS APPLICATION. IF AN ISSUE FEE HAS PREVIOUSLY BEEN PAID IN THIS APPLICATION (AS SHOWN ABOVE), THE RETURN OF PART B OF THIS FORM WILL BE CONSIDERED A REQUEST TO REAPPLY THE PREVIOUSLY PAID ISSUE FEE TOWARD THE ISSUE FEE NOW DUE.

HOW TO REPLY TO THIS NOTICE:

I. Review the SMALL ENTITY status shown above.

If the SMALL ENTITY is shown as YES, verify your current SMALL ENTITY status:

- A. If the status is the same, pay the TOTAL FEE(S) DUE shown above.
B. If the status above is to be removed, check box 5b on Part B - Fee(s) Transmittal and pay the PUBLICATION FEE (if required) and twice the amount of the ISSUE FEE shown above, or

If the SMALL ENTITY is shown as NO:

- A. Pay TOTAL FEE(S) DUE shown above, or
B. If applicant claimed SMALL ENTITY status before, or is now claiming SMALL ENTITY status, check box 5a on Part B - Fee(s) Transmittal and pay the PUBLICATION FEE (if required) and 1/2 the ISSUE FEE shown above.

II. PART B - FEE(S) TRANSMITTAL, or its equivalent, must be completed and returned to the United States Patent and Trademark Office (USPTO) with your ISSUE FEE and PUBLICATION FEE (if required). If you are charging the fee(s) to your deposit account, section "4b" of Part B - Fee(s) Transmittal should be completed and an extra copy of the form should be submitted. If an equivalent of Part B is filed, a request to reapply a previously paid issue fee must be clearly made, and delays in processing may occur due to the difficulty in recognizing the paper as an equivalent of Part B.

III. All communications regarding this application must give the application number. Please direct all communications prior to issuance to Mail Stop ISSUE FEE unless advised to the contrary.

IMPORTANT REMINDER: Utility patents issuing on applications filed on or after Dec. 12, 1980 may require payment of maintenance fees. It is patentee's responsibility to ensure timely payment of maintenance fees when due.

**PART B - FEE(S) TRANSMITTAL**

**Complete and send this form, together with applicable fee(s), to: Mail Mail Stop ISSUE FEE  
 Commissioner for Patents  
 P.O. Box 1450  
 Alexandria, Virginia 22313-1450  
 or Fax (571)-273-2885**

**INSTRUCTIONS:** This form should be used for transmitting the ISSUE FEE and PUBLICATION FEE (if required). Blocks 1 through 5 should be completed where appropriate. All further correspondence including the Patent, advance orders and notification of maintenance fees will be mailed to the current correspondence address as indicated unless corrected below or directed otherwise in Block 1, by (a) specifying a new correspondence address; and/or (b) indicating a separate "FEE ADDRESS" for maintenance fee notifications.

CURRENT CORRESPONDENCE ADDRESS (Note: Use Block 1 for any change of address)

Note: A certificate of mailing can only be used for domestic mailings of the Fee(s) Transmittal. This certificate cannot be used for any other accompanying papers. Each additional paper, such as an assignment or formal drawing, must have its own certificate of mailing or transmission.

62574                      7590                      09/07/2010

Jason H. Vick  
 Sheridan Ross, PC  
 Suite # 1200  
 1560 Broadway  
 Denver, CO 80202

**Certificate of Mailing or Transmission**

I hereby certify that this Fee(s) Transmittal is being deposited with the United States Postal Service with sufficient postage for first class mail in an envelope addressed to the Mail Stop ISSUE FEE address above, or being facsimile transmitted to the USPTO (571) 273-2885, on the date indicated below.

_____ (Depositor's name)
_____ (Signature)
_____ (Date)

APPLICATION NO.	FILING DATE	FIRST NAMED INVENTOR	ATTORNEY DOCKET NO.	CONFIRMATION NO.
12/477,742	06/03/2009	David M. Krinsky	5550-2-CON-2-1	8072

TITLE OF INVENTION: SYSTEM AND METHOD FOR ESTABLISHING A DIAGNOSTIC TRANSMISSION MODE AND COMMUNICATING OVER THE SAME

APPLN. TYPE	SMALL ENTITY	ISSUE FEE DUE	PUBLICATION FEE DUE	PREV. PAID ISSUE FEE	TOTAL FEE(S) DUE	DATE DUE
nonprovisional	NO	\$1510	\$300	\$0	\$1810	12/07/2010

EXAMINER	ART UNIT	CLASS-SUBCLASS
TRAN, KHANH C	2611	375-222000

<p>1. Change of correspondence address or indication of "Fee Address" (37 CFR 1.363).</p> <p><input type="checkbox"/> Change of correspondence address (or Change of Correspondence Address form PTO/SB/122) attached.</p> <p><input type="checkbox"/> "Fee Address" indication (or "Fee Address" Indication form PTO/SB/47; Rev 03-02 or more recent) attached. <b>Use of a Customer Number is required.</b></p>	<p>2. For printing on the patent front page, list</p> <p>(1) the names of up to 3 registered patent attorneys or agents OR, alternatively, 1 _____</p> <p>(2) the name of a single firm (having as a member a registered attorney or agent) and the names of up to 2 registered patent attorneys or agents. If no name is listed, no name will be printed. 2 _____</p> <p>3 _____</p>
---	---

3. ASSIGNEE NAME AND RESIDENCE DATA TO BE PRINTED ON THE PATENT (print or type)

PLEASE NOTE: Unless an assignee is identified below, no assignee data will appear on the patent. If an assignee is identified below, the document has been filed for recordation as set forth in 37 CFR 3.11. Completion of this form is NOT a substitute for filing an assignment.

(A) NAME OF ASSIGNEE \_\_\_\_\_ (B) RESIDENCE: (CITY and STATE OR COUNTRY) \_\_\_\_\_

Please check the appropriate assignee category or categories (will not be printed on the patent) :  Individual  Corporation or other private group entity  Government

<p>4a. The following fee(s) are submitted:</p> <p><input type="checkbox"/> Issue Fee</p> <p><input type="checkbox"/> Publication Fee (No small entity discount permitted)</p> <p><input type="checkbox"/> Advance Order - # of Copies _____</p>	<p>4b. Payment of Fee(s): (<b>Please first reapply any previously paid issue fee shown above</b>)</p> <p><input type="checkbox"/> A check is enclosed.</p> <p><input type="checkbox"/> Payment by credit card. Form PTO-2038 is attached.</p> <p><input type="checkbox"/> The Director is hereby authorized to charge the required fee(s), any deficiency, or credit any overpayment, to Deposit Account Number _____ (enclose an extra copy of this form).</p>
---	---

5. **Change in Entity Status** (from status indicated above)

a. Applicant claims SMALL ENTITY status. See 37 CFR 1.27.  b. Applicant is no longer claiming SMALL ENTITY status. See 37 CFR 1.27(g)(2).

NOTE: The Issue Fee and Publication Fee (if required) will not be accepted from anyone other than the applicant; a registered attorney or agent; or the assignee or other party in interest as shown by the records of the United States Patent and Trademark Office.

Authorized Signature \_\_\_\_\_ Date \_\_\_\_\_

Typed or printed name \_\_\_\_\_ Registration No. \_\_\_\_\_

This collection of information is required by 37 CFR 1.311. The information is required to obtain or retain a benefit by the public which is to file (and by the USPTO to process) an application. Confidentiality is governed by 35 U.S.C. 122 and 37 CFR 1.14. This collection is estimated to take 12 minutes to complete, including gathering, preparing, and submitting the completed application form to the USPTO. Time will vary depending upon the individual case. Any comments on the amount of time you require to complete this form and/or suggestions for reducing this burden, should be sent to the Chief Information Officer, U.S. Patent and Trademark Office, U.S. Department of Commerce, P.O. Box 1450, Alexandria, Virginia 22313-1450. DO NOT SEND FEES OR COMPLETED FORMS TO THIS ADDRESS. SEND TO: Commissioner for Patents, P.O. Box 1450, Alexandria, Virginia 22313-1450.

Under the Paperwork Reduction Act of 1995, no persons are required to respond to a collection of information unless it displays a valid OMB control number.



UNITED STATES PATENT AND TRADEMARK OFFICE

UNITED STATES DEPARTMENT OF COMMERCE
United States Patent and Trademark Office
Address: COMMISSIONER FOR PATENTS
P.O. Box 1450
Alexandria, Virginia 22313-1450
www.uspto.gov

Table with 5 columns: APPLICATION NO., FILING DATE, FIRST NAMED INVENTOR, ATTORNEY DOCKET NO., CONFIRMATION NO. Includes application details for David M. Krinsky and contact information for Jason H. Vick.

Determination of Patent Term Adjustment under 35 U.S.C. 154 (b)

(application filed on or after May 29, 2000)

The Patent Term Adjustment to date is 0 day(s). If the issue fee is paid on the date that is three months after the mailing date of this notice and the patent issues on the Tuesday before the date that is 28 weeks (six and a half months) after the mailing date of this notice, the Patent Term Adjustment will be 0 day(s).

If a Continued Prosecution Application (CPA) was filed in the above-identified application, the filing date that determines Patent Term Adjustment is the filing date of the most recent CPA.

Applicant will be able to obtain more detailed information by accessing the Patent Application Information Retrieval (PAIR) WEB site (http://pair.uspto.gov).

Any questions regarding the Patent Term Extension or Adjustment determination should be directed to the Office of Patent Legal Administration at (571)-272-7702. Questions relating to issue and publication fee payments should be directed to the Customer Service Center of the Office of Patent Publication at 1-(888)-786-0101 or (571)-272-4200.

<b>Notice of Allowability</b>	<b>Application No.</b> 12/477,742	<b>Applicant(s)</b> KRINSKY ET AL.	
	<b>Examiner</b> KHANH C. TRAN	<b>Art Unit</b> 2611	

**-- The MAILING DATE of this communication appears on the cover sheet with the correspondence address--**

All claims being allowable, PROSECUTION ON THE MERITS IS (OR REMAINS) CLOSED in this application. If not included herewith (or previously mailed), a Notice of Allowance (PTOL-85) or other appropriate communication will be mailed in due course. **THIS NOTICE OF ALLOWABILITY IS NOT A GRANT OF PATENT RIGHTS.** This application is subject to withdrawal from issue at the initiative of the Office or upon petition by the applicant. See 37 CFR 1.313 and MPEP 1308.

1.  This communication is responsive to the Amendment filed 8/17/2010.
2.  The allowed claim(s) is/are 47-52, which have been renumbered as claims 1-6, respectively.
3.  Acknowledgment is made of a claim for foreign priority under 35 U.S.C. § 119(a)-(d) or (f).
  - a)  All    b)  Some\*    c)  None    of the:
    1.  Certified copies of the priority documents have been received.
    2.  Certified copies of the priority documents have been received in Application No. \_\_\_\_\_ .
    3.  Copies of the certified copies of the priority documents have been received in this national stage application from the International Bureau (PCT Rule 17.2(a)).

\* Certified copies not received: \_\_\_\_\_.

Applicant has THREE MONTHS FROM THE "MAILING DATE" of this communication to file a reply complying with the requirements noted below. Failure to timely comply will result in ABANDONMENT of this application.

**THIS THREE-MONTH PERIOD IS NOT EXTENDABLE.**

4.  A SUBSTITUTE OATH OR DECLARATION must be submitted. Note the attached EXAMINER'S AMENDMENT or NOTICE OF INFORMAL PATENT APPLICATION (PTO-152) which gives reason(s) why the oath or declaration is deficient.
  5.  CORRECTED DRAWINGS ( as "replacement sheets") must be submitted.
    - (a)  including changes required by the Notice of Draftsperson's Patent Drawing Review ( PTO-948) attached
      - 1)  hereto or 2)  to Paper No./Mail Date \_\_\_\_\_.
    - (b)  including changes required by the attached Examiner's Amendment / Comment or in the Office action of Paper No./Mail Date \_\_\_\_\_.
- Identifying indicia such as the application number (see 37 CFR 1.84(c)) should be written on the drawings in the front (not the back) of each sheet. Replacement sheet(s) should be labeled as such in the header according to 37 CFR 1.121(d).**
6.  DEPOSIT OF and/or INFORMATION about the deposit of BIOLOGICAL MATERIAL must be submitted. Note the attached Examiner's comment regarding REQUIREMENT FOR THE DEPOSIT OF BIOLOGICAL MATERIAL.

**Attachment(s)**

- |   |  |
|---|--|
| <ol style="list-style-type: none"> <li>1. <input type="checkbox"/> Notice of References Cited (PTO-892)</li> <li>2. <input type="checkbox"/> Notice of Draftsperson's Patent Drawing Review (PTO-948)</li> <li>3. <input type="checkbox"/> Information Disclosure Statements (PTO/SB/08),<br/>Paper No./Mail Date _____</li> <li>4. <input type="checkbox"/> Examiner's Comment Regarding Requirement for Deposit of Biological Material</li> </ol> | <ol style="list-style-type: none"> <li>5. <input type="checkbox"/> Notice of Informal Patent Application</li> <li>6. <input type="checkbox"/> Interview Summary (PTO-413),<br/>Paper No./Mail Date _____ .</li> <li>7. <input checked="" type="checkbox"/> Examiner's Amendment/Comment</li> <li>8. <input checked="" type="checkbox"/> Examiner's Statement of Reasons for Allowance</li> <li>9. <input type="checkbox"/> Other _____.</li> </ol> |
|---|--|

/KHANH C. TRAN/  
Primary Examiner, Art Unit 2611

1. The Amendment filed on 8/17/2010 has been entered. Claims 47-52 are still pending in this Office action.

2. Claims 47-52 have been renumbered as claims 1-6, respectively.

### ***Response to Arguments***

3. Applicant's arguments, see Applicants' Remarks, filed 8/17/2010, with respect to claims 47-50 have been fully considered and are persuasive. The rejection of claims 47-50 has been withdrawn.

4. The Terminal Disclaimer filed 8/17/2010 has been approved and entered.

5. The Specification filed 8/17/2010 has been entered.

### ***Reasons for Allowance***

The following is an examiner's statement of reasons for allowance:

6. The instant Application is directed to a transceiver capable of transmitting and receiving, a non-transitory computer-readable information storage media having stored thereon instructions that, if executed, cause a transceiver to perform a method of transmitting and receiving a combination of uniquely distinct features "the message

comprises one or more data variables that represent the test information, wherein bits in the message are modulated onto DMT symbols using Quadrature Amplitude Modulation (QAM) with more than 1 bit per sub-channel and wherein at least one data variable of the one or more data variables comprises an array representing frequency domain received idle channel noise information”.

Any comments considered necessary by applicant must be submitted no later than the payment of the issue fee and, to avoid processing delays, should preferably accompany the issue fee. Such submissions should be clearly labeled “Comments on Statement of Reasons for Allowance.”

### **Conclusion**

7. Any inquiry concerning this communication or earlier communications from the examiner should be directed to KHANH C. TRAN whose telephone number is (571)272-3007. The examiner can normally be reached on Monday - Friday from 08:00 AM - 05:00 PM.

If attempts to reach the examiner by telephone are unsuccessful, the examiner’s supervisor, Shuwang Liu can be reached on 571-272-3036. The fax phone number for the organization where this application or proceeding is assigned is 571-273-8300.

Information regarding the status of an application may be obtained from the Patent Application Information Retrieval (PAIR) system. Status information for published applications may be obtained from either Private PAIR or Public PAIR. Status information for unpublished applications is available through Private PAIR only. For more information about the PAIR system, see <http://pair-direct.uspto.gov>. Should you have questions on access to the Private PAIR system, contact the Electronic Business Center (EBC) at 866-217-9197 (toll-free). If you would like assistance from a USPTO Customer Service Representative or access to the automated information system, call 800-786-9199 (IN USA OR CANADA) or 571-272-1000.

KCT

*/KHANH C. TRAN/  
Primary Examiner, Art Unit 2611*





UNITED STATES PATENT AND TRADEMARK OFFICE

UNITED STATES DEPARTMENT OF COMMERCE  
 United States Patent and Trademark Office  
 Address: COMMISSIONER FOR PATENTS  
 P.O. Box 1450  
 Alexandria, Virginia 22313-1450  
 www.uspto.gov

BIB DATA SHEET

CONFIRMATION NO. 8072

SERIAL NUMBER	FILING or 371(c) DATE	CLASS	GROUP ART UNIT	ATTORNEY DOCKET NO.		
12/477,742	06/03/2009	375	2611	5550-2-CON-2-1		
<b>APPLICANTS</b> David M. Krinsky, Acton, MA; Robert Edmund Pizzano Jr., Stoneham, MA;						
<b>** CONTINUING DATA *****</b> This application is a CON of 10/619,691 07/16/2003 PAT 7,570,686 YES * which is a DIV of 09/755,173 01/08/2001 PAT 6,658,052 YES which claims benefit of 60/224,308 08/10/2000 YES and claims benefit of 60/174,865 01/07/2000 YES * (*) Data provided by applicant is not consistent with PTO records						
<b>** FOREIGN APPLICATIONS *****</b> NO /KCT/ /KCT/						
<b>** IF REQUIRED, FOREIGN FILING LICENSE GRANTED **</b> 06/10/2009						
Foreign Priority claimed <input type="checkbox"/> Yes <input checked="" type="checkbox"/> No 35 USC 119(a-d) conditions met <input type="checkbox"/> Yes <input type="checkbox"/> No Verified and Acknowledged <u>/KHANH C TRAN/</u> Examiner's Signature		<input type="checkbox"/> Met after Allowance KCT Initials	<b>STATE OR COUNTRY</b> MA	<b>SHEETS DRAWINGS</b> 2	<b>TOTAL CLAIMS</b> 6	<b>INDEPENDENT CLAIMS</b> 6
<b>ADDRESS</b> Jason H. Vick Sheridan Ross, PC Suite # 1200 1560 Broadway Denver, CO 80202 UNITED STATES						
<b>TITLE</b> SYSTEM AND METHOD FOR ESTABLISHING A DIAGNOSTIC TRANSMISSION MODE AND COMMUNICATING OVER THE SAME						
<b>FILING FEE RECEIVED</b> 1750	FEES: Authority has been given in Paper No. _____ to charge/credit DEPOSIT ACCOUNT No. _____ for following:		<input type="checkbox"/> All Fees <input type="checkbox"/> 1.16 Fees (Filing) <input type="checkbox"/> 1.17 Fees (Processing Ext. of time) <input type="checkbox"/> 1.18 Fees (Issue) <input type="checkbox"/> Other _____ <input type="checkbox"/> Credit			

<b>Issue Classification</b> 	<b>Application/Control No.</b> 12477742	<b>Applicant(s)/Patent Under Reexamination</b> KRINSKY ET AL.
	<b>Examiner</b> KHANH C TRAN	<b>Art Unit</b> 2611

ORIGINAL						INTERNATIONAL CLASSIFICATION														
CLASS			SUBCLASS			CLAIMED					NON-CLAIMED									
375			222			H	0	4	B	1 / 38 (2006.01.01)										
<b>CROSS REFERENCE(S)</b>						H	0	4	L	12 / 26 (2006.01.01)										
CLASS	SUBCLASS (ONE SUBCLASS PER BLOCK)																			
370	252																			

<input type="checkbox"/> Claims renumbered in the same order as presented by applicant <input type="checkbox"/> CPA <input type="checkbox"/> T.D. <input type="checkbox"/> R.1.47															
Final	Original	Final	Original	Final	Original	Final	Original	Final	Original	Final	Original	Final	Original	Final	Original
-	1	-	17	-	33	3	49								
-	2	-	18	-	34	4	50								
-	3	-	19	-	35	5	51								
-	4	-	20	-	36	6	52								
-	5	-	21	-	37										
-	6	-	22	-	38										
-	7	-	23	-	39										
-	8	-	24	-	40										
-	9	-	25	-	41										
-	10	-	26	-	42										
-	11	-	27	-	43										
-	12	-	28	-	44										
-	13	-	29	-	45										
-	14	-	30	-	46										
-	15	-	31	1	47										
-	16	-	32	2	48										

NONE		<b>Total Claims Allowed:</b>	
		6	
(Assistant Examiner)	(Date)	O.G. Print Claim(s)	O.G. Print Figure
/KHANH C TRAN/ Primary Examiner.Art Unit 2611	08/27/2010	1	1
(Primary Examiner)	(Date)		

<b>Search Notes</b> 	<b>Application/Control No.</b> 12477742	<b>Applicant(s)/Patent Under Reexamination</b> KRINSKY ET AL.
	<b>Examiner</b> KHANH C TRAN	<b>Art Unit</b> 2611

<b>SEARCHED</b>			
<b>Class</b>	<b>Subclass</b>	<b>Date</b>	<b>Examiner</b>

<b>SEARCH NOTES</b>		
<b>Search Notes</b>	<b>Date</b>	<b>Examiner</b>
Update Searches on the Parent Cases US Patent 6,658,052 & US Patent 7,570,686	6/3/2010	KCT
Update EAST Searches & Double Patenting Searches	8/11/2010	KCT

<b>INTERFERENCE SEARCH</b>			
<b>Class</b>	<b>Subclass</b>	<b>Date</b>	<b>Examiner</b>
375	all subclasses previously cited	8/27/2010	KCT
370	all subclasses previously cited		KCT
379	all subclasses previously cited		KCT

	/KHANH C TRAN/ Primary Examiner.Art Unit 2611
--	--

<b>Index of Claims</b>  	<b>Application/Control No.</b>  12477742	<b>Applicant(s)/Patent Under Reexamination</b>  KRINSKY ET AL.
	<b>Examiner</b>  KHANH C TRAN	<b>Art Unit</b>  2611

✓	<b>Rejected</b>	-	<b>Cancelled</b>	N	<b>Non-Elected</b>	A	<b>Appeal</b>
=	<b>Allowed</b>	÷	<b>Restricted</b>	I	<b>Interference</b>	O	<b>Objected</b>

<input type="checkbox"/> Claims renumbered in the same order as presented by applicant		<input type="checkbox"/> CPA		<input type="checkbox"/> T.D.		<input type="checkbox"/> R.1.47	
CLAIM		DATE					
Final	Original	06/03/2010	08/12/2010	08/27/2010			
	1	-	-	-			
	2	-	-	-			
	3	-	-	-			
	4	-	-	-			
	5	-	-	-			
	6	-	-	-			
	7	-	-	-			
	8	-	-	-			
	9	-	-	-			
	10	-	-	-			
	11	-	-	-			
	12	-	-	-			
	13	-	-	-			
	14	-	-	-			
	15	-	-	-			
	16	-	-	-			
	17	-	-	-			
	18	-	-	-			
	19	-	-	-			
	20	-	-	-			
	21	-	-	-			
	22	-	-	-			
	23	-	-	-			
	24	-	-	-			
	25	-	-	-			
	26	-	-	-			
	27	-	-	-			
	28	-	-	-			
	29	-	-	-			
	30	-	-	-			
	31	-	-	-			
	32	-	-	-			
	33	-	-	-			
	34	-	-	-			
	35	-	-	-			
	36	-	-	-			

<b>Index of Claims</b>  	<b>Application/Control No.</b>  12477742	<b>Applicant(s)/Patent Under Reexamination</b>  KRINSKY ET AL.
	<b>Examiner</b>  KHANH C TRAN	<b>Art Unit</b>  2611

✓	<b>Rejected</b>	-	<b>Cancelled</b>	N	<b>Non-Elected</b>	A	<b>Appeal</b>
=	<b>Allowed</b>	÷	<b>Restricted</b>	I	<b>Interference</b>	O	<b>Objected</b>

<input type="checkbox"/> Claims renumbered in the same order as presented by applicant		<input type="checkbox"/> CPA			<input type="checkbox"/> T.D.			<input type="checkbox"/> R.1.47		
CLAIM		DATE								
Final	Original	06/03/2010	08/12/2010	08/27/2010						
	37	-	-	-						
	38	-	-	-						
	39	-	-	-						
	40	-	-	-						
	41	-	-	-						
	42	-	-	-						
	43	-	-	-						
	44	-	-	-						
	45	-	-	-						
	46	-	-	-						
1	47	=	✓	=						
2	48	=	✓	=						
3	49	=	✓	=						
4	50	=	✓	=						
5	51	=	=	=						
6	52	✓	=	=						

## EAST Search History

## EAST Search History (Prior Art)

Ref #	Hits	Search Query	DBs	Default Operator	Plurals	Time Stamp
L1	1	12/477742	US-PGPUB; USPAT	OR	ON	2010/08/27 10:10
S1	674	"375"/\$.CCLS. and (channel adj cod\$5) and diversity	US-PGPUB; USPAT	OR	ON	2005/09/09 09:15
S2	230	"375"/\$.CCLS. and ((channel adj cod\$5) same diversity)	US-PGPUB; USPAT	OR	ON	2007/03/27 07:06
S3	1	"6247158".pn.	US-PGPUB; USPAT	OR	ON	2005/09/08 16:58
S4	7	("4577317"   "5283780"   "5907582"   "5909439"   "5970085"   "6023492"   "6049566").PN.	US-PGPUB; USPAT; USOCR	OR	ON	2005/09/08 17:00
S5	1	"6178196".pn.	US-PGPUB; USPAT; USOCR	OR	ON	2005/09/08 17:00
S6	1	"6389063".PN.	US-PGPUB; USPAT	OR	ON	2005/09/09 09:16
S7	1	"6603807".PN.	US-PGPUB; USPAT	OR	ON	2005/09/09 09:16
S8	1	"6359926".PN.	US-PGPUB; USPAT	OR	ON	2005/09/09 09:16
S9	15	"375"/260.CCLS. and ((channel adj cod\$5) same diversity)	US-PGPUB; USPAT	OR	ON	2005/09/15 15:55
S10	1	"6178196".pn.	US-PGPUB; USPAT	OR	ON	2005/09/15 16:00
S11	1	"6693982".pn.	US-PGPUB; USPAT	OR	ON	2005/09/15 16:41
S12	0	cross adj correlated adj base adj band	US-PGPUB; USPAT	OR	ON	2006/02/24 11:01
S13	762	(cross adj correlated) near2 signal	US-PGPUB; USPAT	OR	ON	2005/09/15 16:42
S14	589	(cross adj correlated) near signal	US-PGPUB; USPAT	OR	ON	2005/09/15 16:42
S15	43	S14 with transmit\$5	US-PGPUB; USPAT	OR	ON	2005/09/15 16:50
S16	362	transmitter same diversity same delay	US-PGPUB; USPAT	OR	ON	2005/09/15 16:51

S17	3	transmitter same diversity same (delay adj path)	US-PGPUB; USPAT	OR	ON	2005/09/15 16:51
S18	1196	diversity with delay	US-PGPUB; USPAT	OR	ON	2005/09/15 17:03
S19	139	diversity same (multi adj user)	US-PGPUB; USPAT	OR	ON	2005/09/15 17:04
S20	15	diversity same (plurality adj user) same transmitter	US-PGPUB; USPAT	OR	ON	2005/09/15 17:12
S21	24	diversity same (plurality adj user) same transmission	US-PGPUB; USPAT	OR	ON	2005/09/15 17:06
S22	0	diversity same (plurality adj user) same (different adj PN)	US-PGPUB; USPAT	OR	ON	2005/09/15 17:11
S23	18	diversity same (plurality adj user) same ( PN adi code)	US-PGPUB; USPAT	OR	ON	2005/09/15 17:12
S24	0	diversity same (plurality adj user) same ( PN adj code)	US-PGPUB; USPAT	OR	ON	2005/09/15 17:12
S25	34	(plurality adj antenna) same (plurality adj user)	US-PGPUB; USPAT	OR	ON	2005/09/15 17:16
S26	17	(plurality adj antenna) same (plurality adj user) same transmi\$5	US-PGPUB; USPAT	OR	ON	2005/09/15 17:17
S27	0	(plurality adj antenna) same (distinct adj signal)	US-PGPUB; USPAT	OR	ON	2005/09/15 17:18
S28	3	(plurality adj antenna) same (different adj spread adj code)	US-PGPUB; USPAT	OR	ON	2005/09/15 17:18
S29	12	(diversity) same (different adj spread adj code)	US-PGPUB; USPAT	OR	ON	2005/09/15 17:19
S30	0	multiusers same (channel adj coder) same (plurality adj antenna)	US-PGPUB; USPAT	OR	ON	2005/09/16 14:54
S31	3	data same (channel adj coder) same (plurality adj antenna)	US-PGPUB; USPAT	OR	ON	2005/09/16 14:54
S32	1	MIMO same (channel adj coder) same (plurality adj antenna)	US-PGPUB; USPAT	OR	ON	2005/09/16 15:03
S33	3	(MIMO same (channel adj coder)) and (plurality adj antenna)	US-PGPUB; USPAT	OR	ON	2005/09/16 14:56

S34	86	multi adj user adj data	US-PGPUB; USPAT	OR	ON	2005/09/16 14:58
S35	2	S34 and mimo	US-PGPUB; USPAT	OR	ON	2005/09/16 14:56
S36	10	S34 and diversity	US-PGPUB; USPAT	OR	ON	2005/09/16 14:57
S37	0	S34 and (seial adj parallel)	US-PGPUB; USPAT	OR	ON	2005/09/16 14:58
S38	0	S34 and (serial adj parallel)	US-PGPUB; USPAT	OR	ON	2005/09/16 14:58
S39	194399	data same channel coder same (plurality adj antenna)	US-PGPUB; USPAT	OR	ON	2005/09/16 14:59
S40	3	data same (channel adj coder) same (plurality adj antenna)	US-PGPUB; USPAT	OR	ON	2005/09/16 14:59
S41	8	data same (coder) same (plurality adj antenna)	US-PGPUB; USPAT	OR	ON	2005/09/16 15:00
S42	31	data and (channel adj coder) and (plurality adj antenna)	US-PGPUB; USPAT	OR	ON	2005/09/16 15:01
S43	3	(channel adj coder) same MIMO	US-PGPUB; USPAT	OR	ON	2005/09/16 15:02
S44	5	(channel adj coder) same (plurality adj antenna)	US-PGPUB; USPAT	OR	ON	2005/09/16 15:03
S45	66	(encoder) same (plurality adj antenna)	US-PGPUB; USPAT	OR	ON	2005/09/16 15:16
S46	5	"6285720"	US-PGPUB; USPAT	OR	ON	2005/09/16 15:06
S47	13	"375"/\$.ccls. and (multi adj user adj data)	US-PGPUB; USPAT	OR	ON	2005/09/16 15:19
S48	48	"375"/\$.ccls. and ((multi adj user) same TDMA)	US-PGPUB; USPAT	OR	ON	2005/09/16 15:20
S49	9	"375"/\$.ccls. and ((multi adj user) same FDD)	US-PGPUB; USPAT	OR	ON	2005/09/16 15:21
S50	10	"370"/\$.ccls. and ((multi adj user) same FDD)	US-PGPUB; USPAT	OR	ON	2005/09/16 15:22
S51	1	"370"/\$.ccls. and ((channel adj encoder) same FDD)	US-PGPUB; USPAT	OR	ON	2005/09/16 15:24
S52	0	"370"/\$.ccls. and ((channel adj coder) same FDD)	US-PGPUB; USPAT	OR	ON	2005/09/16 15:24



S53	1	((channel adj coder) same FDD)	US-PGPUB; USPAT	OR	ON	2005/09/16 15:24
S54	0	((channel adj coder) same (multi adj user))	US-PGPUB; USPAT	OR	ON	2005/09/16 15:24
S55	1	((channel adj encoder) same (multi adj user))	US-PGPUB; USPAT	OR	ON	2005/09/16 15:26
S56	16	((spatial adj diversity) same (multi adj user))	US-PGPUB; USPAT	OR	ON	2005/09/16 15:27
S57	99	((spatial adj diversity) and (multi adj user))	US-PGPUB; USPAT	OR	ON	2005/09/16 15:36
S58	3	"6359864"	US-PGPUB; USPAT	OR	ON	2005/09/16 15:31
S59	106	((FDD and CDMA) and (multi adj user))	US-PGPUB; USPAT	OR	ON	2005/09/16 15:31
S60	11	((spatial adj diversity) and (channel adj coder))	US-PGPUB; USPAT	OR	ON	2005/09/16 15:36
S61	5	"5321725"   "5784417"   "6031474"   "6088408"   "6473878").PN.	US-PGPUB; USPAT; USOCR	OR	ON	2005/09/16 15:48
S62	38154	data adj source	US-PGPUB; USPAT; USOCR	OR	ON	2005/09/16 15:48
S63	19	S62 with (multi adj user)	US-PGPUB; USPAT; USOCR	OR	ON	2005/09/16 15:53
S64	3	(frequency adj division adj duplex) same (multi adj user) same CDMA	US-PGPUB; USPAT; USOCR	OR	ON	2005/09/16 15:51
S65	5	"5559723"   "5905946"   "5933457"   "6161209"   "6615024").PN.	US-PGPUB; USPAT; USOCR	OR	ON	2005/09/16 15:52
S66	0	(multi adj user adj source)	US-PGPUB; USPAT; USOCR	OR	ON	2005/09/16 15:53
S67	25	((multi adj user) near2 source)	US-PGPUB; USPAT; USOCR	OR	ON	2005/09/16 15:53
S68	23266	((multi adj user) near2 source) amd MIMO	US-PGPUB; USPAT; USOCR	OR	ON	2005/09/16 15:53
S69	0	((multi adj user) near2 source) and MIMO	US-PGPUB; USPAT; USOCR	OR	ON	2005/09/16 15:55
S70	1	"6693982".pn.	US-PGPUB; USPAT; USOCR	OR	ON	2005/09/16 16:11
S71	1	"5886967".pn.	US-PGPUB; USPAT; USOCR	OR	ON	2005/09/16 16:11
S72	1	"5886987".pn.	US-PGPUB; USPAT; USOCR	OR	ON	2005/09/16 16:13
S73	6	(information adj source) near2 (different adj source)	US-PGPUB; USPAT; USOCR	OR	ON	2005/09/16 16:13

S74	323	"375"/\$.ccls. and (multiple adj access adj interference)	US-PGPUB; USPAT; USOCR	OR	ON	2005/09/16 16:14
S75	32	"375"/\$.ccls. and (multiple adj access adj interference) and (demultiplex\$5)	US-PGPUB; USPAT; USOCR	OR	ON	2005/09/16 16:16
S76	7	"375"/\$.ccls. and (multiple adj access adj interference) and (demultiplex\$5) and coder	US-PGPUB; USPAT; USOCR	OR	ON	2005/09/16 16:14
S77	28	"375"/\$.ccls. and (multiple adj channel) and (channel adj coder)	US-PGPUB; USPAT; USOCR	OR	ON	2005/09/16 16:16
S78	1	"6741658".pn.	US-PGPUB; USPAT	OR	ON	2005/09/18 08:43
S79	1	"6898248".pn.	US-PGPUB; USPAT	OR	ON	2005/09/18 08:44
S80	1	"6359864".pn.	US-PGPUB; USPAT	OR	ON	2006/02/21 10:50
S81	1	"6310923".pn.	US-PGPUB; USPAT	OR	ON	2006/02/21 10:50
S82	3	375/267.ccls. and (transmit near (different adj information))	US-PGPUB; USPAT	OR	ON	2006/02/24 13:52
S83	1	"6693982".pn.	US-PGPUB; USPAT	OR	ON	2006/02/24 15:16
S84	561	mapper with identif\$8	US-PGPUB; USPAT	OR	ON	2006/02/24 15:16
S85	71	"375"/\$.ccls. and (mapper with identif\$8)	US-PGPUB; USPAT	OR	ON	2006/02/24 15:16
S86	1	"6693982".pn.	US-PGPUB; USPAT	OR	ON	2006/02/27 09:36
S87	171	space adj time adj block adj code	US-PGPUB; USPAT	OR	ON	2006/02/27 13:37
S88	25	S87 and (spread adj spectrum)	US-PGPUB; USPAT	OR	ON	2006/02/27 10:11
S89	2	S87 and (spread adj code)	US-PGPUB; USPAT	OR	ON	2006/02/27 09:36
S90	126	(angle adj diversity)	US-PGPUB; USPAT	OR	ON	2006/02/27 10:12
S91	0	S87 and S90	US-PGPUB; USPAT	OR	ON	2006/02/27 10:11
S92	155	space adj time adj diversity	US-PGPUB; USPAT	OR	ON	2006/02/27 10:12
S93	3	S90 and S92	US-PGPUB; USPAT	OR	ON	2006/02/27 10:12

S94	3	(angle adj diversity) same (fading adj channel)	US-PGPUB; USPAT	OR	ON	2006/02/27 10:17
S95	1	(angle adj diversity) same (directed adj antenna adj beam)	US-PGPUB; USPAT	OR	ON	2006/02/27 10:17
S96	1	((plurality adj antenna) same (code adj rate) same adapt\$8)	US-PGPUB; USPAT	OR	ON	2006/02/27 10:54
S97	4	((plurality adj antenna) same (code adj rate)) and adapt\$8	US-PGPUB; USPAT	OR	ON	2006/02/27 10:55
S98	0	((plurality adj antenna) same (adapt\$8 adj code adj rate))	US-PGPUB; USPAT	OR	ON	2006/02/27 10:55
S99	0	((adaptive adj antenna) same (adapt\$8 adj code adj rate))	US-PGPUB; USPAT	OR	ON	2006/02/27 10:55
S100	0	((adaptive adj antenna) and (adapt\$8 adj code adj rate))	US-PGPUB; USPAT	OR	ON	2006/02/27 15:02
S101	94	((adaptive adj modulation) and (adaptive adj cod\$5))	US-PGPUB; USPAT	OR	ON	2006/02/27 13:11
S102	1	"5383219".pn.	US-PGPUB; USPAT	OR	ON	2006/02/27 13:36
S103	50	S87 and (transmit adj power)	US-PGPUB; USPAT	OR	ON	2006/02/27 13:43
S104	1	"6693982".pn.	US-PGPUB; USPAT	OR	ON	2006/02/27 14:05
S105	5828	channel adj estimat\$5	US-PGPUB; USPAT	OR	ON	2006/02/27 14:05
S106	1751	channel adj estimator	US-PGPUB; USPAT	OR	ON	2006/02/27 14:06
S107	48	S106 same (channel adj equalizer)	US-PGPUB; USPAT	OR	ON	2006/02/27 14:08
S108	3	S107 and (space adj time)	US-PGPUB; USPAT	OR	ON	2006/02/27 14:08
S109	7	375/267.ccls. and recod \$5	US-PGPUB; USPAT	OR	ON	2006/02/27 15:07
S110	3	("5781845"   "6067324"   "6122260").PN.	US-PGPUB; USPAT; USOCR	OR	ON	2006/02/27 15:06
S111	3	"375"/\$.ccls. and recod \$5 and (MAI)	US-PGPUB; USPAT	OR	ON	2006/02/27 15:08
S112	1	"375"/\$.ccls. and reencod\$5 and (MAI)	US-PGPUB; USPAT	OR	ON	2006/02/27 15:10
S113	7	reencod\$5 and (MAI)	US-PGPUB; USPAT	OR	ON	2006/02/27 15:08

S114	0	"375"/148.ccls. and reencod\$5 and (MAI)	US-PGPUB; USPAT	OR	ON	2006/02/27 15:14
S115	0	"375"/148.ccls. and reencod\$5 and (space adj time adj diversity)	US-PGPUB; USPAT	OR	ON	2006/02/27 15:14
S116	0	"375"/\$.ccls. and reencod\$5 and (space adj time adj diversity)	US-PGPUB; USPAT	OR	ON	2006/02/27 15:14
S117	0	"375"/\$.ccls. and reencod\$5 and ((space adj time) near2 code)	US-PGPUB; USPAT	OR	ON	2006/02/27 15:15
S118	0	"375"/\$.ccls. and reencod\$5 and ((space adj time) with code)	US-PGPUB; USPAT	OR	ON	2006/02/27 15:15
S119	7	"375"/\$.ccls. and (re adj encod\$5) and ((space adj time) with code)	US-PGPUB; USPAT	OR	ON	2006/02/27 15:15
S120	56	375/260.ccls. and Channeliz\$6	US-PGPUB; USPAT	OR	ON	2006/08/10 16:58
S121	180	375/267.ccls. and (space adj time adj cod \$8)	US-PGPUB; USPAT	OR	ON	2006/08/11 11:15
S122	1	"6366888".pn.	US-PGPUB; USPAT	OR	ON	2006/08/11 11:15
S123	3	375/267.ccls. and (non adj interleav\$8)	US-PGPUB; USPAT	OR	ON	2006/08/11 11:17
S124	11	375/260.ccls. and (non adj interleav\$8)	US-PGPUB; USPAT	OR	ON	2006/08/11 11:22
S125	0	"375"/\$.ccls. and ((inner adj cod\$5) same (outer adj cod\$6) same(non adj interleav \$8))	US-PGPUB; USPAT	OR	ON	2006/08/11 11:24
S126	2	"375"/\$.ccls. and ((inner adj cod\$5) same (outer adj cod \$6)) and(non adj interleav\$8)	US-PGPUB; USPAT	OR	ON	2006/08/11 11:24
S127	0	"375"/\$.ccls. and ((outer adj cod\$6) same (non adj interleav\$8))	US-PGPUB; USPAT	OR	ON	2006/08/11 11:25
S128	3	"375"/267.ccls. and (( cod\$6) same(non adj interleav\$8))	US-PGPUB; USPAT	OR	ON	2006/08/11 11:25
S129	2	"375"/267.ccls. and (( transmit\$5) with(non adj interleav\$8))	US-PGPUB; USPAT	OR	ON	2006/08/11 11:27

S130	4	"375"/267.ccls. and (( transmit\$5) with (without adj interleav \$8))	US-PGPUB; USPAT	OR	ON	2006/08/11 11:27
S131	180	"375"/267.ccls. and (space adj time adj cod \$6)	US-PGPUB; USPAT	OR	ON	2006/08/11 11:28
S132	1	"6115427".pn.	US-PGPUB; USPAT	OR	ON	2006/08/16 08:06
S133	1	"6693982".pn.	US-PGPUB; USPAT	OR	ON	2006/08/16 08:06
S134	3	09/393235	US-PGPUB; USPAT	OR	ON	2006/08/16 13:47
S135	353	combin\$3 with serializ \$3	US-PGPUB; USPAT	OR	ON	2006/08/16 13:48
S136	3383513	number of transmitter antennas	US-PGPUB; USPAT	OR	ON	2007/03/20 07:30
S137	1	10/184054	US-PGPUB; USPAT	OR	ON	2007/03/20 09:21
S138	1	10/619691	US-PGPUB; USPAT	OR	ON	2007/03/20 09:37
S139	1	"6636603".pn.	US-PGPUB; USPAT	OR	ON	2007/03/20 09:41
S140	1	"20040202237"	US-PGPUB; USPAT	OR	ON	2007/03/20 15:17
S141	1	09/798727	US-PGPUB; USPAT	OR	ON	2007/03/20 15:17
S142	1	"6745050".pn.	US-PGPUB; USPAT	OR	ON	2007/03/23 08:55
S143	6	("20020097779"   "4794556"   "4941178"   "5668830"   "6480557"   "RE31943").PN.	US-PGPUB; USPAT; USOCR	OR	OFF	2007/03/23 08:55
S144	695	CDMA same (multi adj user)	US-PGPUB; USPAT; USOCR	OR	OFF	2007/03/23 08:55
S145	374	"375"/\$.ccls. and (CDMA same (multi adj user))	US-PGPUB; USPAT; USOCR	OR	OFF	2007/03/23 08:56
S146	287	"375"/\$.ccls. and (CDMA with (multi adj user))	US-PGPUB; USPAT; USOCR	OR	OFF	2007/03/23 08:56
S147	0	"375"/\$.ccls. and (CDMA with (multi adj user)) and (interference adj cancel\$&)	US-PGPUB; USPAT; USOCR	OR	OFF	2007/03/23 08:57

S148	89	"375"/\$.ccls. and (CDMA with (multi adj user)) and (interference adj cancel\$5)	US-PGPUB; USPAT; USOCR	OR	OFF	2007/03/23 08:57
S149	8	("4134071"   "4744093"   "5136612"   "5164959"   "5361219"   "5363403"   "5481533"   "5790590").PN.	US-PGPUB; USPAT; USOCR	OR	OFF	2007/03/23 08:58
S150	14	("5956333").URPN.	USPAT	OR	OFF	2007/03/23 09:01
S151	1	09/326222.app.	US-PGPUB; USPAT; DERWENT; IBM_TDB	OR	OFF	2007/03/23 09:01
S152	11	("4124818"   "4992798"   "5418814"   "5467368"   "5566165"   "5596600"   "5724378"   "5956333"   "6032026"   "6088383"   "6229857").PN.	US-PGPUB; USPAT; USOCR	OR	OFF	2007/03/23 09:03
S153	11	"375"/\$.ccls. and (multi adj user adj demodul \$8)	US-PGPUB; USPAT; USOCR	OR	OFF	2007/03/27 11:53
S154	0	"375"/\$.ccls. and (multi adj user ) and remodult \$6	US-PGPUB; USPAT; USOCR	OR	OFF	2007/03/23 09:09
S155	23	"375"/\$.ccls. and (multi adj user ) and remodulat\$6	US-PGPUB; USPAT; USOCR	OR	OFF	2007/03/23 09:05
S156	0	"370"/\$.ccls. and (multi adj user ) and remodult \$6	US-PGPUB; USPAT; USOCR	OR	OFF	2007/03/23 09:09
S157	0	"455"/\$.ccls. and (multi adj user ) and remodult \$6	US-PGPUB; USPAT; USOCR	OR	OFF	2007/03/23 09:10
S158	0	"455"/\$.ccls. and ( user ) and remodult\$6	US-PGPUB; USPAT; USOCR	OR	OFF	2007/03/23 09:10
S159	237	"455"/\$.ccls. and ( user ) and remodulat \$6	US-PGPUB; USPAT; USOCR	OR	OFF	2007/03/23 09:10
S160	10	"455"/\$.ccls. and ( multiuser ) and remodulat\$6	US-PGPUB; USPAT; USOCR	OR	OFF	2007/03/23 09:11
S161	30	( multiuser ) and remodulat\$6 and CDMA	US-PGPUB; USPAT; USOCR	OR	OFF	2007/03/23 09:14
S162	873	( multiuser ) and CDMA	US-PGPUB; USPAT; USOCR	OR	OFF	2007/03/23 09:14

S163	523	"375"/\$.ccls. and (multiuser) and CDMA	US-PGPUB; USPAT; USOCR	OR	OFF	2007/03/23 09:14
S164	299	"375"/\$.ccls. and ((multiuser) same CDMA)	US-PGPUB; USPAT; USOCR	OR	OFF	2007/03/23 09:14
S165	1	"5956333".pn.	US-PGPUB; USPAT	OR	ON	2007/03/26 09:23
S166	1	"5644592".pn.	US-PGPUB; USPAT	OR	ON	2007/03/26 09:30
S167	1	10/184054	US-PGPUB; USPAT	OR	ON	2007/03/26 10:06
S168	1	"6115427".pn.	US-PGPUB; USPAT	OR	ON	2007/03/26 10:28
S169	49	375/267.ccls. and (multiuser)	US-PGPUB; USPAT	OR	ON	2007/03/26 10:32
S170	6	375/260.ccls. and (multiuser same diversity)	US-PGPUB; USPAT	OR	ON	2007/03/26 10:33
S171	2	375/295.ccls. and (multiuser same diversity)	US-PGPUB; USPAT	OR	ON	2007/03/26 10:34
S172	8	375/130.ccls. and (multiuser same diversity)	US-PGPUB; USPAT	OR	ON	2007/03/26 10:38
S173	1	375/299.ccls. and (multiuser same diversity)	US-PGPUB; USPAT	OR	ON	2007/03/26 10:35
S174	16	375/299.ccls. and (multiuser)	US-PGPUB; USPAT	OR	ON	2007/03/26 10:35
S175	41	375/130.ccls. and (multiuser)	US-PGPUB; USPAT	OR	ON	2007/03/26 10:38
S176	13	375/130.ccls. and (multiuser and PN)	US-PGPUB; USPAT	OR	ON	2007/03/26 10:40
S177	355	375/299.ccls.	US-PGPUB; USPAT	OR	ON	2007/03/26 10:40
S178	167	375/299.ccls. and user	US-PGPUB; USPAT	OR	ON	2007/03/26 10:40
S179	10	375/299.ccls. and (user same PN)	US-PGPUB; USPAT	OR	ON	2007/03/26 10:53
S180	708	"375"/\$.ccls. and (multi adj user) and CDMA	US-PGPUB; USPAT	OR	ON	2007/03/26 10:54
S181	294	"375"/\$.ccls. and (multi adj user) and CDMA and diversity	US-PGPUB; USPAT	OR	ON	2007/03/26 10:54
S182	19	"375"/\$.ccls. and ((multi adj user) same CDMA same diversity)	US-PGPUB; USPAT	OR	ON	2007/03/26 10:59

S183	14	"455"/\$.ccls. and ((multi adj user) same CDMA same diversity)	US-PGPUB; USPAT	OR	ON	2007/03/26 11:03
S184	134	"375"/267.ccls. and ((user) same CDMA )	US-PGPUB; USPAT	OR	ON	2007/03/26 11:18
S185	0	"375"/267.ccls. and (variable near3 rate) same (number adj antenna)	US-PGPUB; USPAT	OR	ON	2007/03/26 11:19
S186	9	"375"/267.ccls. and (variable near3 rate) and (number adj antenna)	US-PGPUB; USPAT	OR	ON	2007/03/26 11:19
S187	7	"375"/\$.ccls. and (variable near3 rate) and (number adj antenna) and (variable adj coding adj rate)	US-PGPUB; USPAT	OR	ON	2007/03/26 11:34
S188	1	"6349216".pn.	US-PGPUB; USPAT	OR	ON	2007/03/26 11:35
S189	53	"4041395"   "4147985"   "4165493"   "4348644"   "4356458"   "4370622"   "4442407"   "4546313"   "4647871"   "4827219"   "4890062"   "4924191"   "4985686"   "4990866"   "4994757"   "5060294"   "5101172"   "5113414"   "5119040"   "5170496"   "5195045"   "5220276"   "5251330"   "5251331"   "5276912"   "5278997"   "5300894"   "5302914"   "5329244"   "5339041"   "5351016"   "5361403"   "5408691"   "5420536"   "5428828"   "5483680"   "5553318"   "5564086"   "5589796"   "5598127"   "5640691"   "5673001"   "5694433"   "5742201"   "5880633"   "5901346"   "5905407"   "5907797"   "6020787"   "6069525"   "6141541"   "6160449"	US-PGPUB; USPAT; USOCR	OR	OFF	2007/03/26 13:31



		"6166598").PN.				
S190	1	"6947491".pn.	US-PGPUB; USPAT; USOCR	OR	OFF	2007/03/26 14:03
S191	188	(code adj rate) and (increas\$5 with antenna)	US-PGPUB; USPAT; USOCR	OR	OFF	2007/03/26 14:04
S192	6	(code adj rate) same (increas\$5 with antenna)	US-PGPUB; USPAT; USOCR	OR	OFF	2007/03/26 15:23
S193	243	375/267.ccls. and (close loop adj power adj control)	US-PGPUB; USPAT; USOCR	OR	OFF	2007/03/26 15:23
S194	1986913	375/267.ccls. and multiuser (close loop adj power adj control)	US-PGPUB; USPAT; USOCR	OR	OFF	2007/03/26 15:24
S195	7	375/267.ccls. and multiuser and (close loop adj power adj control)	US-PGPUB; USPAT; USOCR	OR	OFF	2007/03/26 15:24
S196	0	375/267.ccls. and multiuser and (close\$2 adj loop adj power adj control)	US-PGPUB; USPAT; USOCR	OR	OFF	2007/03/26 15:25
S197	1	"6115406".pn.	US-PGPUB; USPAT; USOCR	OR	OFF	2007/03/26 15:25
S198	6	("4901307"   "5652764"   "5886987"   "5952968"   "5982327"   "5991332").PN.	US-PGPUB; USPAT; USOCR	OR	OFF	2007/03/26 15:31
S199	13	("4835790"   "5267262"   "5347535"   "5412686"   "5485486"   "5548835"   "5559789"   "5574983"   "5581547"   "5590409"   "5598404"   "5604766"   "5646937").PN.	US-PGPUB; USPAT; USOCR	OR	OFF	2007/03/26 15:45
S200	26	("5886987").URPN.	USPAT	OR	OFF	2007/03/26 15:47
S201	13	("4835790"   "5267262"   "5347535"   "5412686"   "5485486"   "5548835"   "5559789"   "5574983"   "5581547"   "5590409"   "5598404"   "5604766"   "5646937").PN.	US-PGPUB; USPAT; USOCR	OR	OFF	2007/03/26 15:57
S202	5	"375"/267.OCLS. and (MIMO and (MAI))	US-PGPUB; USPAT	OR	ON	2007/03/27 07:06

S203	7	"375"/260.CCLS. and (MIMO and (MAI))	US-PGPUB; USPAT	OR	ON	2007/03/27 07:07
S204	30	"375"/\$.CCLS. and (MIMO and (MAI))	US-PGPUB; USPAT	OR	ON	2007/03/27 07:08
S205	18	"370"/\$.CCLS. and (MIMO and (MAI))	US-PGPUB; USPAT	OR	ON	2007/03/27 07:09
S206	7	"455"/\$.CCLS. and (MIMO and (MAI))	US-PGPUB; USPAT	OR	ON	2007/03/27 07:09
S207	10	"455"/\$.CCLS. and (OFDM and (MAI))	US-PGPUB; USPAT	OR	ON	2007/03/27 07:12
S208	39	"370"/\$.CCLS. and (OFDM and (MAI))	US-PGPUB; USPAT	OR	ON	2007/03/27 07:10
S209	39	"375"/\$.CCLS. and (OFDM and (MAI))	US-PGPUB; USPAT	OR	ON	2007/03/27 08:04
S210	1	"6115427".pn.	US-PGPUB; USPAT	OR	ON	2007/03/27 08:05
S211	81	(code adj rate) same (number near antenna)	US-PGPUB; USPAT	OR	ON	2007/03/27 08:20
S212	1	"6560295".pn.	US-PGPUB; USPAT	OR	ON	2007/03/27 08:52
S213	387	(space adj time) same CDMA	US-PGPUB; USPAT	OR	ON	2007/03/27 08:53
S214	68	375/267.ccls. and ((space adj time) same CDMA)	US-PGPUB; USPAT	OR	ON	2007/03/27 09:15
S215	2	375/267.ccls. and (compar\$8 with uplink with downlink)	US-PGPUB; USPAT	OR	ON	2007/03/27 09:16
S216	1	375/222.ccls. and (compar\$8 with uplink with downlink)	US-PGPUB; USPAT	OR	ON	2007/03/27 09:21
S217	0	375/222.ccls. and ((compar\$8 with uplink with downlink) same interference)	US-PGPUB; USPAT	OR	ON	2007/03/27 09:21
S218	9	"375"/\$.ccls. and ((compar\$8 with uplink with downlink) same interference)	US-PGPUB; USPAT	OR	ON	2007/03/27 09:22
S219	0	"375"/222.ccls. and (diagnostic adj bit)	US-PGPUB; USPAT; USOCR	OR	OFF	2007/03/27 11:54
S220	0	"375"/222.ccls. and (diagnostic adj tone)	US-PGPUB; USPAT; USOCR	OR	OFF	2007/03/27 11:54
S221	0	"370"/\$.ccls. and (diagnostic adj tone)	US-PGPUB; USPAT; USOCR	OR	OFF	2007/03/27 13:14
S222	19	"370"/\$.ccls. and (diagnostic with tone)	US-PGPUB; USPAT; USOCR	OR	OFF	2007/03/27 13:17
S223	0	375/222.ccls. and (diagnostic adj tone)	US-PGPUB; USPAT	OR	ON	2007/03/27 13:19

S224	0	375/222.ccls. and (diagnostic with tone)	US-PGPUB; USPAT	OR	ON	2007/03/27 13:19
S225	22	375/222.ccls. and (diagnostic with bit)	US-PGPUB; USPAT	OR	ON	2007/03/27 13:26
S226	8	"5889856"   "6137839"   "6263016"   "6374288"   "6400759"   "6442195"   "6477595"   "6594306").PN.	US-PGPUB; USPAT; USOCR	OR	OFF	2007/03/27 13:22
S227	0	375/222.ccls. and (diagnostic with DMT )	US-PGPUB; USPAT	OR	ON	2007/03/27 13:43
S228	0	"375"/\$.ccls. and (diagnostic with DMT )	US-PGPUB; USPAT	OR	ON	2007/03/27 13:26
S229	0	"370"/\$.ccls. and (diagnostic with DMT )	US-PGPUB; USPAT	OR	ON	2007/03/27 13:26
S230	0	"370"/\$.ccls. and (diagnostic same DMT )	US-PGPUB; USPAT	OR	ON	2007/03/27 13:27
S231	1	"375"/\$.ccls. and (diagnostic same DMT )	US-PGPUB; USPAT	OR	ON	2007/03/27 13:39
S232	113	"375"/\$.ccls. and (diagnostic same message)	US-PGPUB; USPAT	OR	ON	2007/03/27 13:39
S233	4	"375"/\$.ccls. and (diagnostic same message) and DMT	US-PGPUB; USPAT	OR	ON	2007/03/27 13:41
S234	6	"370"/\$.ccls. and (diagnostic same message) and DMT	US-PGPUB; USPAT	OR	ON	2007/03/27 13:42
S235	0	"370"/\$.ccls. and (diagnostic same DMT)	US-PGPUB; USPAT	OR	ON	2007/03/27 13:42
S236	1	"375"/\$.ccls. and (diagnostic same DMT)	US-PGPUB; USPAT	OR	ON	2007/03/27 13:45
S237	15	(diagnostic same DMT)	US-PGPUB; USPAT	OR	ON	2007/03/27 13:43
S238	1	375/222.ccls. and (diagnostic adj message)	US-PGPUB; USPAT	OR	ON	2007/03/27 13:43
S239	0	375/260.ccls. and (diagnostic adj message) and DMT	US-PGPUB; USPAT	OR	ON	2007/03/27 13:44
S240	0	375/260.ccls. and (diagnostic adj message)	US-PGPUB; USPAT	OR	ON	2007/03/27 13:44
S241	21	375/260.ccls. and (diagnostic )	US-PGPUB; USPAT	OR	ON	2007/03/27 13:44
S242	5	375/260.ccls. and (diagnostic ) and DMT	US-PGPUB; USPAT	OR	ON	2007/03/27 13:45

S243	5	375/260.ccls. and (diagnostic ) and OFDM	US-PGPUB; USPAT	OR	ON	2007/03/27 13:45
S244	1	"379"/\$.ccls. and (diagnostic same DMT)	US-PGPUB; USPAT	OR	ON	2007/03/27 13:45
S245	5	"379"/\$.ccls. and (diagnostic same bins)	US-PGPUB; USPAT	OR	ON	2007/03/27 13:46
S246	3	"375"/\$.ccls. and (diagnostic same bins)	US-PGPUB; USPAT	OR	ON	2007/03/27 13:46
S247	12	"370"/\$.ccls. and (diagnostic same bins)	US-PGPUB; USPAT	OR	ON	2007/03/27 13:47
S248	3	"370"/\$.ccls. and (bit with diagnostic ) and DMT	US-PGPUB; USPAT	OR	ON	2007/03/27 13:48
S249	7	"375"/\$.ccls. and (bit with diagnostic ) and DMT	US-PGPUB; USPAT	OR	ON	2007/03/27 13:50
S250	0	"702"/\$.ccls. and (bit with diagnostic ) and DMT	US-PGPUB; USPAT	OR	ON	2007/03/27 13:50
S251	0	"370"/249.ccls. and (bit with diagnostic ) and DMT	US-PGPUB; USPAT	OR	ON	2007/03/27 13:52
S252	0	"370"/249.ccls. and ( diagnostic ) and DMT	US-PGPUB; USPAT	OR	ON	2007/03/27 13:52
S253	65	"370"/249.ccls. and ( diagnostic )	US-PGPUB; USPAT	OR	ON	2007/03/27 13:52
S254	1	"370"/249.ccls. and ( diagnostic adj message )	US-PGPUB; USPAT	OR	ON	2007/03/27 13:52
S255	1	"370"/249.ccls. and ( initiat\$5 near2 diagnostic )	US-PGPUB; USPAT	OR	ON	2007/03/27 14:37
S256	0	diagnostic same (DMT adj symbol)	US-PGPUB; USPAT	OR	ON	2007/03/27 14:37
S257	0	diagnostic same (DMT adj symbol)	US-PGPUB; USPAT	OR	ON	2007/03/27 14:37
S258	0	"375"/\$.ccls. and (diagnostic same (DMT adj symbol))	US-PGPUB; USPAT	OR	ON	2007/03/27 14:37
S259	9	"375"/\$.ccls. and (diagnostic and (DMT adj symbol))	US-PGPUB; USPAT	OR	ON	2007/03/27 14:57
S260	1	"375"/\$.ccls. and (diagnostic same DMT )	US-PGPUB; USPAT	OR	ON	2007/03/27 14:58
S261	19	"375"/\$.ccls. and (bit near2 diagnostic )	US-PGPUB; USPAT	OR	ON	2007/03/27 15:00
S262	1	"375"/\$.ccls. and (map \$5 with (bit near2 diagnostic )	US-PGPUB; USPAT	OR	ON	2007/03/27 15:00

S263	12	"4566100"   "5128619"   "5608643"   "5864602"   "5964891"   "6075821"   "6188717"   "6219378"   "6404774"   "6411678"   "6449307"   "6512789").PN.	US-PGPUB; USPAT; USOCR	OR	OFF	2007/03/27 15:07
S264	0	map\$7 with diagnostic with DMT	US-PGPUB; USPAT; USOCR	OR	OFF	2007/03/27 15:08
S265	0	map\$7 with diagnostic with DMT	US-PGPUB; USPAT; IBM_TDB	OR	OFF	2007/03/27 15:09
S266	0	map\$7 with (diagnostic adj bit) with DMT	US-PGPUB; USPAT; IBM_TDB	OR	OFF	2007/03/27 15:09
S267	1	375/260.ccls. and DMT and diagnostic	US-PGPUB; USPAT; IBM_TDB	OR	OFF	2007/03/27 15:13
S268	13	375/222.ccls. and DMT and diagnostic	US-PGPUB; USPAT; IBM_TDB	OR	OFF	2007/03/27 15:10
S269	0	375/260.ccls. and (diagnostic adj bit)	US-PGPUB; USPAT; IBM_TDB	OR	OFF	2007/03/27 15:13
S270	1	"375"/\$.ccls. and (diagnostic adj bit)	US-PGPUB; USPAT; IBM_TDB	OR	OFF	2007/03/27 15:13
S271	1	"379"/\$.ccls. and (diagnostic adj bit)	US-PGPUB; USPAT; IBM_TDB	OR	OFF	2007/03/27 15:14
S272	69	(diagnostic adj bit)	US-PGPUB; USPAT; IBM_TDB	OR	OFF	2007/03/27 15:15
S273	0	(diagnostic adj bit) and DMT	US-PGPUB; USPAT; IBM_TDB	OR	OFF	2007/03/27 15:14
S274	0	(diagnostic adj bit) and multicarrier	US-PGPUB; USPAT; IBM_TDB	OR	OFF	2007/03/27 15:14
S275	0	(diagnostic adj meassage) and (DMT adj symbol)	US-PGPUB; USPAT; IBM_TDB	OR	OFF	2007/03/27 15:16
S276	1	(diagnostic adj message) and (DMT adj symbol)	US-PGPUB; USPAT; IBM_TDB	OR	OFF	2007/03/27 16:15
S277	4	10/127164	US-PGPUB; USPAT; IBM_TDB	OR	OFF	2007/03/27 16:15

S278	44	"20020006169"   "20020191709"   "20030067995"   "3898566"   "4878232"   "5163181"   "5228055"   "5249201"   "5490172"   "5493587"   "5579342"   "5608760"   "5621762"   "5636247"   "5638404"   "5651028"   "5727026"   "5751705"   "5805640"   "5822360"   "5930678"   "5991262"   "6009090"   "6032029"   "6041081"   "6125103"   "6128351"   "6130918"   "6175551"   "6222873"   "6229995"   "6236864"   "6240141"   "6246725"   "6294956"   "6356606"   "6449302"   "6504862"   "6687511"   "6701163"   "6931053"   "6931079"   "6931239"   "6931240").PN.	US-PGPUB; USPAT; USOCR	OR	OFF	2007/03/27 16:19
S279	1	"5930678".pn.	US-PGPUB; USPAT; USOCR	OR	OFF	2007/03/27 16:19
S280	0	(diagnostic adj DMT)	US-PGPUB; USPAT	OR	ON	2007/03/28 07:37
S281	29	(diagnostic adj tone)	US-PGPUB; USPAT	OR	ON	2007/03/28 07:37
S282	0	"375"/\$.ccls. and (diagnostic adj tone)	US-PGPUB; USPAT	OR	ON	2007/03/28 07:37
S283	0	"375"/\$.ccls. and (diagnostic near tone)	US-PGPUB; USPAT	OR	ON	2007/03/28 07:37
S284	7	"375"/\$.ccls. and (diagnostic near bits)	US-PGPUB; USPAT	OR	ON	2007/03/28 07:38
S285	0	"375"/\$.ccls. and (diagnos\$6 near DMT)	US-PGPUB; USPAT	OR	ON	2007/03/28 07:38
S286	0	"375"/\$.ccls. and (diagnos\$6 with DMT)	US-PGPUB; USPAT	OR	ON	2007/03/28 07:38
S287	479	"375"/\$.ccls. and (bit with DMT)	US-PGPUB; USPAT	OR	ON	2007/03/28 07:39
S288	207	"375"/\$.ccls. and (bit near3 DMT)	US-PGPUB; USPAT	OR	ON	2007/03/28 07:39

S289	13	"375"/\$.ccls. and (bit near3 DMT) and diagnost\$5	US-PGPUB; USPAT	OR	ON	2007/03/28 07:47
S290	1	"375"/\$.ccls. and ( DMT same diagnost\$5)	US-PGPUB; USPAT	OR	ON	2007/03/28 07:47
S291	40	"375"/\$.ccls. and ( DMT and diagnost\$5)	US-PGPUB; USPAT	OR	ON	2007/03/28 07:49
S292	43	"375"/222.ccls. and ( diagnost\$5 near3 modem)	US-PGPUB; USPAT	OR	ON	2007/03/28 07:50
S293	10	"375"/222.ccls. and ( diagnost\$5 near3 modem) and DMT	US-PGPUB; USPAT	OR	ON	2007/03/28 07:56
S294	0	"370"/484.ccls. and ( diagnost\$5 near3 modem) and DMT	US-PGPUB; USPAT	OR	ON	2007/03/28 07:52
S295	0	"370"/484.ccls. and ( diagnost\$5 ) and DMT	US-PGPUB; USPAT	OR	ON	2007/03/28 07:52
S296	1	"370"/484.ccls. and ( diagnost\$5 )	US-PGPUB; USPAT	OR	ON	2007/03/28 07:52
S297	16	"370"/480.ccls. and ( diagnost\$5 )	US-PGPUB; USPAT	OR	ON	2007/03/28 07:52
S298	11	"375"/222.ccls. and ( diagnost\$5 adj mode)	US-PGPUB; USPAT	OR	ON	2007/03/28 08:08
S299	1	"6658052".pn.	US-PGPUB; USPAT	OR	ON	2007/03/28 08:26
S300	96171	(one adj bit)	US-PGPUB; USPAT	OR	ON	2007/03/28 08:27
S301	5	(one adj bit) with (DMT adj symbol)	US-PGPUB; USPAT	OR	ON	2007/03/28 08:28
S302	197	(bit) with (DMT adj symbol)	US-PGPUB; USPAT	OR	ON	2007/03/28 08:28
S303	27	(bit) with (DMT adj symbol) and (diagnost\$7)	US-PGPUB; USPAT	OR	ON	2007/03/28 08:30
S304	0	(bit near test\$5) with (DMT adj symbol)	US-PGPUB; USPAT	OR	ON	2007/03/28 08:31
S305	0	(diagnost near tone) and (DMT adj symbol)	US-PGPUB; USPAT	OR	ON	2007/03/28 08:31
S306	0	(diagnost\$5 near tone) and (DMT adj symbol)	US-PGPUB; USPAT	OR	ON	2007/03/28 08:31
S307	0	(diagnost\$5 near tone) and (DMT )	US-PGPUB; USPAT	OR	ON	2007/03/28 08:31
S308	0	(diagnost\$5 near carrier) and (DMT )	US-PGPUB; USPAT	OR	ON	2007/03/28 08:36
S309	5	diagnost\$5 with (DMT )	US-PGPUB; USPAT	OR	ON	2007/03/28 09:12

S310	106	(Pulse adj width adj modulat\$6) same (FSK)	US-PGPUB; USPAT	OR	ON	2007/03/28 10:04
S311	1	"6633545".pn.	US-PGPUB; USPAT	OR	ON	2007/03/28 10:48
S312	1	10/619691	US-PGPUB; USPAT	OR	ON	2007/03/28 10:48
S313	1	"6633545".pn.	US-PGPUB; USPAT	OR	ON	2007/03/29 09:09
S314	1	"6673179".pn.	US-PGPUB; USPAT	OR	ON	2007/03/29 09:09
S315	1	"6073179".pn.	US-PGPUB; USPAT	OR	ON	2007/03/29 09:10
S316	0	"375"/\$.ccls. and (diagnos\$6 same ((frequency adj domain) with (idle adj channel adj noise)))	US-PGPUB; USPAT	OR	ON	2008/05/27 09:52
S317	0	(diagnos\$6 same ((frequency adj domain) with (idle adj channel adj noise)))	US-PGPUB; USPAT	OR	ON	2008/05/27 09:52
S318	0	(diagnos\$6 and ((frequency adj domain) with (idle adj channel adj noise)))	US-PGPUB; USPAT	OR	ON	2008/05/27 09:52
S319	0	"10619691".pn.	US-PGPUB; USPAT	OR	ON	2008/05/27 10:03
S320	1	"10/619691"	US-PGPUB; USPAT	OR	ON	2008/05/27 10:03
S321	1	"10619691"	US-PGPUB; USPAT	OR	ON	2008/06/08 23:12
S322	0	"375"/\$.ccls. and ((diagnostic adj information) same (DMT adj symbol))	US-PGPUB; USPAT	OR	ON	2008/06/08 23:32
S323	0	"375"/\$.ccls. and ((diagnostic) with (DMT adj symbol))	US-PGPUB; USPAT	OR	ON	2008/06/08 23:32
S324	0	"379"/\$.ccls. and ((diagnostic) with (DMT adj symbol))	US-PGPUB; USPAT	OR	ON	2008/06/08 23:33
S325	0	"375"/\$.ccls. and ((diagnostic) with (DMT ))	US-PGPUB; USPAT	OR	ON	2008/06/08 23:33
S326	0	"375"/\$.ccls. and ((diagnostic) with (DMT ))	US-PGPUB; USPAT; DERWENT; IBM_TDB	OR	ON	2008/06/08 23:33



S327	1	"375"/\$.ccls. and ((diagnostic) same (DMT ))	US-PGPUB; USPAT; DERWENT; IBM_TDB	OR	ON	2008/06/08 23:33
S328	4	"375"/\$.ccls. and ((diagnostic) same (multicarrier))	US-PGPUB; USPAT; DERWENT; IBM_TDB	OR	ON	2008/06/08 23:34
S329	3	"375"/\$.ccls. and ((diagnostic adj information) same (multicarrier))	US-PGPUB; USPAT; DERWENT; IBM_TDB	OR	ON	2008/06/08 23:34
S330	26	"375"/222.ccls. and ((diagnostic adj information) )	US-PGPUB; USPAT; DERWENT; IBM_TDB	OR	ON	2008/06/08 23:35
S331	2	09/925509	US-PGPUB; USPAT	OR	ON	2008/06/09 07:54
S332	12	09/755173	US-PGPUB; USPAT	OR	ON	2008/06/09 07:55
S333	142	idle adj channel adj noise	US-PGPUB; USPAT	OR	ON	2008/06/09 08:08
S334	3	S333 and DMT	US-PGPUB; USPAT	OR	ON	2008/06/09 08:09
S335	2	S333 same (diagnostic)	US-PGPUB; USPAT	OR	ON	2008/06/09 08:11
S336	256150	S333 ande (diagnostic)	US-PGPUB; USPAT	OR	ON	2008/06/09 08:14
S337	20	S333 and (diagnostic)	US-PGPUB; USPAT	OR	ON	2008/06/09 08:14
S338	32	(diagnostic adj symbol)	US-PGPUB; USPAT	OR	ON	2008/06/09 08:21
S339	0	"375"/\$.ccls and (diagnostic adj symbol)	US-PGPUB; USPAT	OR	ON	2008/06/09 08:22
S340	0	"370"/\$.ccls and (diagnostic adj symbol)	US-PGPUB; USPAT	OR	ON	2008/06/09 08:22
S341	0	"370"/\$.ccls with (diagnostic adj symbol)	US-PGPUB; USPAT	OR	ON	2008/06/09 08:22
S342	0	"375"/\$.ccls with (diagnostic adj symbol)	US-PGPUB; USPAT	OR	ON	2008/06/09 08:22
S343	0	"375"/\$.ccls with (diagnostic same symbol)	US-PGPUB; USPAT	OR	ON	2008/06/09 08:22
S344	0	"370"/\$.ccls with (test adj symbol)	US-PGPUB; USPAT	OR	ON	2008/06/09 08:23
S345	0	"370"/\$.ccls with (test with symbol)	US-PGPUB; USPAT	OR	ON	2008/06/09 08:23
S346	0	"375"/\$.ccls with (test with symbol)	US-PGPUB; USPAT	OR	ON	2008/06/09 08:23

S347	0	"370"/\$.ccls with (testing with symbol)	US-PGPUB; USPAT	OR	ON	2008/06/09 08:24
S348	5	(test\$6 with (DMT adj symbol))	US-PGPUB; USPAT	OR	ON	2008/06/09 08:24
S349	0	(diagnos\$6 with (DMT adj symbol))	US-PGPUB; USPAT	OR	ON	2008/06/09 08:25
S350	0	(diagnos\$6 same (DMT adj symbol))	US-PGPUB; USPAT	OR	ON	2008/06/09 08:26
S351	646	(map\$7same (DMT adj symbol))	US-PGPUB; USPAT	OR	ON	2008/06/09 08:26
S352	0	((diagnostic) with (DMT adj symbol))	US-PGPUB; USPAT	OR	ON	2008/06/09 08:27
S353	0	((diagnostic) same (DMT adj symbol))	US-PGPUB; USPAT	OR	ON	2008/06/09 08:27
S354	9421	transmit\$7 with diagnostic	US-PGPUB; USPAT	OR	ON	2008/06/09 09:42
S355	185	"375"/\$.ccls. and (transmit\$7 with diagnostic)	US-PGPUB; USPAT	OR	ON	2008/06/09 09:42
S356	79	"375"/\$.ccls. and (transmit\$7 near3 diagnostic)	US-PGPUB; USPAT	OR	ON	2008/06/09 09:42
S357	11	"375"/222.ccls. and (diagnostic adj mode)	US-PGPUB; USPAT	OR	ON	2008/10/06 09:00
S358	4	"375"/222.ccls. and (idle adj channel adj noise)	US-PGPUB; USPAT	OR	ON	2008/10/06 09:15
S359	1	"6658052".pn.	US-PGPUB; USPAT	OR	ON	2008/10/06 09:17
S360	13	"375"/\$.ccls. and modem and (idle adj channel adj noise)	US-PGPUB; USPAT	OR	ON	2008/10/06 09:20
S361	749	(diagnostic with tone)	US-PGPUB; USPAT	OR	ON	2008/10/10 11:04
S362	0	375/222.ccls. and (diagnostic with tone)	US-PGPUB; USPAT	OR	ON	2008/10/10 11:04
S363	0	375/222.ccls. and (diagnostic adj bits)	US-PGPUB; USPAT	OR	ON	2008/10/10 11:04
S364	26	375/222.ccls. and (diagnostic with bits)	US-PGPUB; USPAT	OR	ON	2008/10/10 11:04
S365	0	375/222.ccls. and (diagnostic with DMT)	US-PGPUB; USPAT	OR	ON	2008/10/10 11:07
S366	0	375/222.ccls. and (diagnostic with tone)	US-PGPUB; USPAT	OR	ON	2008/10/10 11:07
S367	10	"375"/\$.ccls. and (diagnostic with tone)	US-PGPUB; USPAT	OR	ON	2008/10/10 11:07
S368	6	(diagnostic with DMT)	US-PGPUB; USPAT	OR	ON	2008/10/10 11:08

S369	6	375/222.ccls. and (diagnostic adj information) and DMT	US-PGPUB; USPAT	OR	ON	2008/10/10 11:09
S370	2	"20020031167"	US-PGPUB; USPAT	OR	ON	2008/10/10 14:18
S371	2	"20010047424"	US-PGPUB; USPAT	OR	ON	2008/10/10 14:21
S372	1	"6697969".pn.	US-PGPUB; USPAT	OR	ON	2008/10/10 14:50
S373	1	"6510162".pn.	US-PGPUB; USPAT	OR	ON	2008/10/10 15:10
S374	1	(upgrad\$7 adj firmware) with (cable adj modem)	US-PGPUB; USPAT	OR	ON	2008/10/10 15:26
S375	1	(upgrad\$7 adj firmware) same (cable adj modem)	US-PGPUB; USPAT	OR	ON	2008/10/10 15:27
S376	0	(upgrad\$7 adj firmware) same (CMTS and TFTP)	US-PGPUB; USPAT	OR	ON	2008/10/10 15:27
S377	1	(upgrad\$7 adj firmware) and (CMTS and TFTP)	US-PGPUB; USPAT	OR	ON	2008/10/10 15:27
S378	932	(upgrad\$7 adj firmware)	US-PGPUB; USPAT	OR	ON	2008/10/10 15:27
S379	29	(upgrad\$7 adj firmware) same modem	US-PGPUB; USPAT	OR	ON	2008/10/10 15:28
S380	1	CMTS and ((upgrad\$7 adj firmware) same modem)	US-PGPUB; USPAT	OR	ON	2008/10/10 15:29
S381	1	CMTS same (upgrad\$7 adj firmware)	US-PGPUB; USPAT	OR	ON	2008/10/10 15:43
S382	282	CMTS same (digital adj subscriber adj line)	US-PGPUB; USPAT	OR	ON	2008/10/10 15:49
S383	186	CMTS with (digital adj subscriber adj line)	US-PGPUB; USPAT	OR	ON	2008/10/10 15:49
S384	28	"375"/\$.ccls. and (idle adj channel adj noise)	US-PGPUB; USPAT	OR	ON	2008/10/13 09:07
S385	0	"375"/\$.ccls. and (diagnostic same (idle adj channel adj noise))	US-PGPUB; USPAT	OR	ON	2008/10/13 09:12
S386	3	"375"/\$.ccls. and (diagnostic and (idle adj channel adj noise))	US-PGPUB; USPAT	OR	ON	2008/10/13 09:12
S387	20	(diagnostic and (idle adj channel adj noise))	US-PGPUB; USPAT	OR	ON	2008/10/13 09:13
S388	1	(diagnostic adj message) and (idle adj channel adj noise)	US-PGPUB; USPAT	OR	ON	2008/10/13 09:15

S389	1	(diagnostic ) and (idle adj channel adj noise) and DMT	US-PGPUB; USPAT	OR	ON	2008/10/13 09:15
S390	3	(diagnostic adj mode ) and (idle adj channel adj noise)	US-PGPUB; USPAT	OR	ON	2008/10/13 09:15
S391	15	(diagnostic ) and (idle adj channel adj noise) and modem	US-PGPUB; USPAT	OR	ON	2008/10/13 09:16
S392	20	(diagnostic ) and (idle adj channel adj noise)	US-PGPUB; USPAT	OR	ON	2008/10/13 09:17
S393	1	"6631120".pn.	US-PGPUB; USPAT	OR	ON	2008/10/13 09:27
S394	1	10/619691	US-PGPUB; USPAT	OR	ON	2008/10/13 10:17
S395	12	09/755173	US-PGPUB; USPAT	OR	ON	2008/10/13 10:39
S396	0	09/597926	US-PGPUB; USPAT	OR	ON	2008/10/13 10:44
S397	1	10/619691	US-PGPUB; USPAT	OR	ON	2009/04/28 08:48
S398	1	"6658052".pn.	US-PGPUB; USPAT	OR	ON	2009/04/28 08:52
S399	1353	(diagnostic adj message)	US-PGPUB; USPAT	OR	ON	2009/04/28 08:53
S400	42	(diagnostic adj message) same variables	US-PGPUB; USPAT	OR	ON	2009/04/28 08:53
S401	0	((diagnostic adj message) same variables) and multicarrier	US-PGPUB; USPAT	OR	ON	2009/04/28 08:53
S402	0	((diagnostic adj message) same variables) and DMT	US-PGPUB; USPAT	OR	ON	2009/04/28 08:53
S403	2	((diagnostic adj message) same variables same array)	US-PGPUB; USPAT	OR	ON	2009/04/28 08:54
S404	1	"7251199".pn.	US-PGPUB; USPAT	OR	ON	2009/04/28 09:14
S405	1	11/510121	US-PGPUB; USPAT	OR	ON	2009/04/28 09:31
S406	345	(diagnostic near bits)	US-PGPUB; USPAT	OR	ON	2009/04/29 09:36
S407	0	(diagnostic near bits) same (DMT)	US-PGPUB; USPAT	OR	ON	2009/04/29 09:37
S408	1	(diagnostic near bits) and (DMT near symbol)	US-PGPUB; USPAT	OR	ON	2009/04/29 09:37

S409	1	(diagnostic near bits) same (symbol)	US-PGPUB; USPAT	OR	ON	2009/04/29 09:38
S410	0	375/222.ccls. and ((diagnostic near bits) same DMT)	US-PGPUB; USPAT	OR	ON	2009/04/29 09:39
S411	3	375/222.ccls. and ((diagnostic near bits) )	US-PGPUB; USPAT	OR	ON	2009/04/29 09:39
S412	0	375/222.ccls. and ((test near bits) with DMT)	US-PGPUB; USPAT	OR	ON	2009/04/29 09:40
S413	1	375/222.ccls. and ((pattern near bits) with DMT)	US-PGPUB; USPAT	OR	ON	2009/04/29 09:40
S414	2	375/222.ccls. and (diagnostic near message)	US-PGPUB; USPAT	OR	ON	2009/04/29 09:41
S415	13	375/222.ccls. and (diagnostic with messages)	US-PGPUB; USPAT	OR	ON	2009/04/29 09:42
S416	43	375/222.ccls. and (diagnostic with information)	US-PGPUB; USPAT	OR	ON	2009/04/29 09:47
S417	0	375/222.ccls. and ((diagnostic with information) same variables same DMT)	US-PGPUB; USPAT	OR	ON	2009/04/29 09:48
S418	3	375/222.ccls. and ((diagnostic with information) same variables )	US-PGPUB; USPAT	OR	ON	2009/04/29 09:48
S419	0	375/222.ccls. and ((diagnostic with information) same DMT)	US-PGPUB; USPAT	OR	ON	2009/04/29 09:50
S420	9	375/222.ccls. and ((diagnostic with information) and DMT)	US-PGPUB; USPAT	OR	ON	2009/04/29 09:50
S421	0	375/222.ccls. and ((diagnostic with mode) same DMT)	US-PGPUB; USPAT	OR	ON	2009/04/29 09:54
S422	4	375/222.ccls. and ((diagnostic with symbol) )	US-PGPUB; USPAT	OR	ON	2009/04/29 09:54
S423	28	375/222.ccls. and ((diagnostic with bits) )	US-PGPUB; USPAT	OR	ON	2009/04/29 09:55
S424	3	375/222.ccls. and ((diagnostic with bits) ) and (channel near noise)	US-PGPUB; USPAT	OR	ON	2009/04/29 09:55

S425	7	"375"/\$.ccls. and ((diagnostic with bits) ) and (channel near noise)	US-PGPUB; USPAT	OR	ON	2009/04/29 09:56
S426	3	"375"/\$.ccls. and ((diagnostic with symbols) ) and (channel near noise)	US-PGPUB; USPAT	OR	ON	2009/04/29 10:02
S427	3	((diagnostic with symbols) ) and (channel near noise)	US-PGPUB; USPAT	OR	ON	2009/04/29 10:03
S428	0	((diagnostic with DMT) ) and (channel near noise)	US-PGPUB; USPAT	OR	ON	2009/04/29 10:03
S429	188	((diagnostic with information) ) and (channel near noise)	US-PGPUB; USPAT	OR	ON	2009/04/29 10:03
S430	3	((diagnostic with information) ) same (channel near noise)	US-PGPUB; USPAT	OR	ON	2009/04/29 10:03
S431	0	((diagnostic with DMT) ) same (channel near noise)	US-PGPUB; USPAT	OR	ON	2009/04/29 10:04
S432	0	((diagnostic same DMT) ) same (channel near noise)	US-PGPUB; USPAT	OR	ON	2009/04/29 10:04
S433	1	"6631130".pn.	US-PGPUB; USPAT	OR	ON	2009/04/29 10:05
S434	1	"6631120".pn.	US-PGPUB; USPAT	OR	ON	2009/04/29 10:06
S435	1	"6788705".pn.	US-PGPUB; USPAT	OR	ON	2009/04/29 10:27
S436	0	(diagonostic with tone)	US-PGPUB; USPAT	OR	ON	2009/05/05 12:00
S437	781	(diagnostic with tone)	US-PGPUB; USPAT	OR	ON	2009/05/05 12:01
S438	10	"375"/\$.ccls. and (diagnostic with tone)	US-PGPUB; USPAT	OR	ON	2009/05/05 12:01
S439	158	"375"/\$.ccls. and (diagnostic with bits)	US-PGPUB; USPAT	OR	ON	2009/05/05 12:02
S440	11	"375"/\$.ccls. and ((diagnostic adj information) with bits)	US-PGPUB; USPAT	OR	ON	2009/05/05 12:02
S441	0	"375"/\$.ccls. and (map \$7 same (diagnostic adj information) same bits same tone)	US-PGPUB; USPAT	OR	ON	2009/05/05 12:10
S442	8781	"375"/\$.ccls. and (map \$7 same (diagnostic ) ssame tone)	US-PGPUB; USPAT	OR	ON	2009/05/05 12:10

S443	0	"375"/\$.ccls. and (map \$7 with (diagnostic ) with tone)	US-PGPUB; USPAT	OR	ON	2009/05/05 12:10
S444	0	"375"/\$.ccls. and (map \$7 with (diagnostic ) with DMT)	US-PGPUB; USPAT	OR	ON	2009/05/05 12:10
S445	0	(map\$7 with (diagnostic ) with DMT)	US-PGPUB; USPAT	OR	ON	2009/05/05 12:10
S446	0	(map\$7 with (test ) with DMT)	US-PGPUB; USPAT	OR	ON	2009/05/05 12:10
S447	0	((diagnostic near bits) with DMT)	US-PGPUB; USPAT	OR	ON	2009/05/05 13:10
S448	0	((diagnostic near bits) same DMT)	US-PGPUB; USPAT	OR	ON	2009/05/05 13:10
S449	2	((diagnostic with bits) same DMT)	US-PGPUB; USPAT	OR	ON	2009/05/05 13:10
S450	0	((diagnostic near bits) same tone)	US-PGPUB; USPAT	OR	ON	2009/05/05 13:11
S451	1	"6658052".pn.	US-PGPUB; USPAT	OR	ON	2009/05/05 13:24
S452	29	"375"/222.ccls. and (diagnostic adj information)	US-PGPUB; USPAT	OR	ON	2009/05/05 14:22
S453	1	10/619691	US-PGPUB; USPAT	OR	ON	2009/05/05 14:32
S454	22	(one adj bit) with DMT	US-PGPUB; USPAT	OR	ON	2009/05/05 14:39
S455	13	09/755173	US-PGPUB; USPAT	OR	ON	2009/05/05 14:51
S456	1	"6658052".pn.	US-PGPUB; USPAT	OR	ON	2009/05/05 14:51
S457	1	"6658052".pn.	US-PGPUB; USPAT	OR	ON	2009/05/07 11:23
S458	1	10/619691	US-PGPUB; USPAT	OR	ON	2009/05/07 11:33
S459	1	"6658052".pn.	US-PGPUB; USPAT	OR	ON	2009/05/08 06:38
S460	7	(diagnostic adj information) same (array) same variables	US-PGPUB; USPAT	OR	ON	2009/05/08 06:53
S461	0	"375"/\$.ccls. and ( (diagnostic adj information) same (array) same variables)	US-PGPUB; USPAT	OR	ON	2009/05/08 06:53
S462	6	"375"/\$.ccls. and ( (diagnostic adj information) same variables)	US-PGPUB; USPAT	OR	ON	2009/05/08 06:53

S463	3	"379"/\$.ccls. and ( (diagnostic adj information) same variables)	US-PGPUB; USPAT	OR	ON	2009/05/08 06:54
S464	21	"370"/\$.ccls. and ( (diagnostic adj information) same variables)	US-PGPUB; USPAT	OR	ON	2009/05/08 06:54
S465	10	"370"/\$.ccls. and ( (diagnostic adj information) same variables) and modems	US-PGPUB; USPAT	OR	ON	2009/05/08 06:55
S466	2	(message with bits with diagnostic) same DMT	US-PGPUB; USPAT	OR	ON	2010/05/27 09:45
S467	0	(message with bits with test) same DMT	US-PGPUB; USPAT	OR	ON	2010/05/27 09:46
S468	0	(message with bits with test\$6) same DMT	US-PGPUB; USPAT	OR	ON	2010/05/27 09:46
S469	9	(message with test\$6) same DMT	US-PGPUB; USPAT	OR	ON	2010/05/27 09:46
S470	5	"375"/\$.ccls. and "370"/\$.ccls. and ((test\$6 with tone) same DMT)	US-PGPUB; USPAT	OR	ON	2010/05/27 09:47
S471	11	((digital with test\$6 with tone) same DMT)	US-PGPUB; USPAT	OR	ON	2010/05/27 10:10
S472	3	"375"/\$.ccls. and "370"/\$.ccls. and ((test\$6 with bit with tone) and DMT)	US-PGPUB; USPAT	OR	ON	2010/05/27 10:11
S473	63	"375"/\$.ccls. and "370"/\$.ccls. and ((modulat\$5 with bit with tone) and DMT)	US-PGPUB; USPAT	OR	ON	2010/05/27 10:12
S474	0	"375"/\$.ccls. and "370"/\$.ccls. and ((modulat\$5 with bits with tone) and (test adj information) and DMT)	US-PGPUB; USPAT	OR	ON	2010/05/27 10:13
S475	2	"375"/\$.ccls. and "370"/\$.ccls. and ((modulat\$5 with bit with tone) and DMT) and (data near variables)	US-PGPUB; USPAT	OR	ON	2010/05/27 10:18
S476	0	"375"/\$.ccls. and "370"/\$.ccls. and ((modulat\$5 with bit with tone with (channel adj noise)) and DMT)	US-PGPUB; USPAT	OR	ON	2010/05/27 10:20



S477	1	"375"/\$.ccls. and "370"/\$.ccls. and ((modulat\$5 with bit with tone) same (channel adj noise)) and DMT	US-PGPUB; USPAT	OR	ON	2010/05/27 10:21
S478	3	((modulat\$5 with bit with tone) same (channel adj noise)) and DMT	US-PGPUB; USPAT	OR	ON	2010/05/27 10:24
S479	1	(send with (channel adj noise)) and DMT	US-PGPUB; USPAT	OR	ON	2010/05/27 10:26
S480	7	(messag\$3 with (channel adj noise)) and DMT	US-PGPUB; USPAT	OR	ON	2010/05/27 10:27
S481	4	(bits with DMT with (channel adj noise)) and DMT	US-PGPUB; USPAT	OR	ON	2010/05/27 10:28
S482	1656	message same variable same test	US-PGPUB; USPAT	OR	ON	2010/06/03 09:44
S483	3	message same variable same test same DMT	US-PGPUB; USPAT	OR	ON	2010/06/03 09:44
S484	0	message same variable same test same QAM	US-PGPUB; USPAT	OR	ON	2010/06/03 09:44
S485	19	(message same variable same test) and DMT	US-PGPUB; USPAT	OR	ON	2010/06/03 09:45
S486	1	"6658052".pn.	US-PGPUB; USPAT	OR	ON	2010/06/03 09:47
S487	1	"6445773".pn.	US-PGPUB; USPAT	OR	ON	2010/06/03 10:48
S488	1	"6075821".pn.	US-PGPUB; USPAT	OR	ON	2010/06/03 11:11
S489	1	12/477742	US-PGPUB; USPAT	OR	ON	2010/06/14 09:18
S490	1	"7570686".pn.	US-PGPUB; USPAT	OR	ON	2010/06/14 09:22
S491	1	"6658052".pn.	US-PGPUB; USPAT	OR	ON	2010/06/14 09:25
S492	18	"375"/\$.ccls. and (diagnostic near message)	US-PGPUB; USPAT	OR	ON	2010/06/14 09:38
S493	2	"375"/\$.ccls. and "379"/\$.ccls. and (diagnostic near message)	US-PGPUB; USPAT	OR	ON	2010/06/14 09:38
S494	2	DMT same (diagnostic near message)	US-PGPUB; USPAT	OR	ON	2010/06/14 09:48
S495	2	DMT and ((diagnostic near message) same (channel adj noise))	US-PGPUB; USPAT	OR	ON	2010/06/14 09:49

S496	3	DMT and ((diagnostic near message) and (channel adj noise))	US-PGPUB; USPAT	OR	ON	2010/06/14 09:49
S497	2	((diagnostic near message) same (channel adj noise))	US-PGPUB; USPAT	OR	ON	2010/06/14 10:00
S498	3	((diagnostic near message) and (channel adj noise))	US-PGPUB; USPAT	OR	ON	2010/06/14 10:02
S499	1	"6445773".pn.	US-PGPUB; USPAT	OR	ON	2010/06/14 10:29
S500	6	"375"/\$.ccls. and (message same test same DMT)	US-PGPUB; USPAT	OR	ON	2010/08/04 10:00
S501	144	"375"/\$.ccls. and (test near message)	US-PGPUB; USPAT	OR	ON	2010/08/04 10:01
S502	0	"375"/\$.ccls. and ((test near message) same DMT)	US-PGPUB; USPAT	OR	ON	2010/08/04 10:01
S503	1	"375"/\$.ccls. and ((test near message) and DMT)	US-PGPUB; USPAT	OR	ON	2010/08/04 10:01
S504	1	"6445773".pn.	US-PGPUB; USPAT	OR	ON	2010/08/04 10:11
S505	8	(DMT with tone) same (channel near noise)	US-PGPUB; USPAT	OR	ON	2010/08/04 10:18
S506	365	(tone with test with information)	US-PGPUB; USPAT	OR	ON	2010/08/04 10:21
S507	15	(tone near test near information)	US-PGPUB; USPAT	OR	ON	2010/08/04 10:21
S508	58	message with (DMT adj symbols)	US-PGPUB; USPAT	OR	ON	2010/08/04 10:30
S509	2	message with (DMT adj symbols) with (channel adj noise)	US-PGPUB; USPAT	OR	ON	2010/08/04 10:30
S510	4	message with (DMT adj symbols) with (noise)	US-PGPUB; USPAT	OR	ON	2010/08/04 10:30
S511	0	(test near2 information) with (DMT adj symbols)	US-PGPUB; USPAT	OR	ON	2010/08/04 10:32
S512	0	(test near information) with (DMT adj symbols)	US-PGPUB; USPAT	OR	ON	2010/08/04 10:32
S513	0	(test with information) with (DMT adj symbols)	US-PGPUB; USPAT	OR	ON	2010/08/04 10:32
S514	0	(test with information) with (DMT adj symbol)	US-PGPUB; USPAT	OR	ON	2010/08/04 10:32
S515	8	(test with information) with (DMT )	US-PGPUB; USPAT	OR	ON	2010/08/04 10:32
S516	1	"6658052".pn.	US-PGPUB; USPAT	OR	ON	2010/08/04 10:35

S517	0	(test near result) with (DMT adj symbols)	US-PGPUB; USPAT	OR	ON	2010/08/04 10:42
S518	0	(test near result) with (DMT adj tine)	US-PGPUB; USPAT	OR	ON	2010/08/04 10:42
S519	0	(test near result) with (DMT adj tone)	US-PGPUB; USPAT	OR	ON	2010/08/04 10:42
S520	295	(test near result) with (tones)	US-PGPUB; USPAT	OR	ON	2010/08/04 10:42
S521	25	(test near result) near (tones)	US-PGPUB; USPAT	OR	ON	2010/08/04 10:43
S522	0	DMT and ((test near result) near (tones))	US-PGPUB; USPAT	OR	ON	2010/08/04 10:43
S523	0	DMT and ((test near result) near (tone))	US-PGPUB; USPAT	OR	ON	2010/08/04 10:43
S524	8	DMT and ((test near result) with (tone))	US-PGPUB; USPAT	OR	ON	2010/08/04 10:44
S525	1	11/911155	US-PGPUB; USPAT	OR	ON	2010/08/11 11:20

8/ 27/ 2010 10:41:47 AM

C:\ Documents and Settings\ ktran5\ My Documents\ EAST\ workspaces\ 12477742.wsp

<b>Application Number</b> 	<b>Application/Control No.</b> 12/477,742	<b>Applicant(s)/Patent under Reexamination</b> KRINSKY ET AL.	
<b>Document Code - DISQ</b>		<b>Internal Document – DO NOT MAIL</b>	

<b>TERMINAL DISCLAIMER</b>	<input checked="" type="checkbox"/> <b>APPROVED</b>	<input type="checkbox"/> <b>DISAPPROVED</b>
Date Filed : 8/17/10	<b>This patent is subject to a Terminal Disclaimer</b>	

<b>Approved/Disapproved by:</b>
Felicia D. Roberts 7,570,686

IN THE UNITED STATES PATENT AND TRADEMARK OFFICE

In Re the Application of: David M. Krinsky	)	Group Art Unit: 2611
	)	
Application No.: 12/477,742	)	Examiner: TRAN, Khanh C.
	)	
Filed: June 3, 2009	)	Confirmation No.: 8072
	)	
Atty. File No.: 5550-2-CON-2-1	)	
	)	

For: MULTICARRIER MODULATION MESSAGING FOR FREQUENCY DOMAIN  
RECEIVED IDLE CHANNEL NOISE INFORMATION

**AMENDMENT AND RESPONSE**

Commissioner for Patents  
P.O. Box 1450  
Alexandria, VA 22313-1450

Sir:

Applicants submit this Amendment and Response to address the Office Action having a mailing date of August 16, 2010. Please credit any overpayment or charge any underpayment to Deposit Account No. 19-1970.

Please amend the above-identified patent application as follows:

**Amendments to the Specification** begin on page 2 of this paper.

**Amendments to the Claims** are shown in the listing of claims which begins on page 3 of this paper.

**Remarks** begin on page 5 of this paper.

AMENDMENTS TO THE SPECIFICATION

Please change the title to read as follows:

SYSTEM AND METHOD FOR ESTABLISHING A DIAGNOSTIC TRANSMISSION MODE  
AND COMMUNICATING OVER THE SAME MULTICARRIER MODULATION  
MESSAGING FOR FREQUENCY DOMAIN RECEIVED IDLE CHANNEL NOISE  
INFORMATION

**AMENDMENTS TO THE CLAIMS:**

This listing of claims will replace all prior versions, and listings, of claims in the application.

**Listing of Claims:**

1. – 46. (Cancelled)

47. (Previously Presented) A transceiver capable of transmitting test information over a communication channel using multicarrier modulation comprising:

a transmitter portion capable of transmitting a message, wherein the message comprises one or more data variables that represent the test information, wherein bits in the message are modulated onto DMT symbols using Quadrature Amplitude Modulation (QAM) with more than 1 bit per subchannel and wherein at least one data variable of the one or more data variables comprises an array representing frequency domain received idle channel noise information.

48. (Previously Presented) A transceiver capable of receiving test information over a communication channel using multicarrier modulation comprising:

a receiver portion capable of receiving a message, wherein the message comprises one or more data variables that represent the test information, wherein bits in the message were modulated onto DMT symbols using Quadrature Amplitude Modulation (QAM) with more than 1 bit per subchannel and wherein at least one data variable of the one or more data variables comprises an array representing frequency domain received idle channel noise information.

49. (Previously Presented) In a transceiver capable of transmitting test information over a communication channel using multicarrier modulation, a method comprising:

transmitting a message, wherein the message comprises one or more data variables that represent the test information, wherein bits in the message are modulated onto DMT symbols using Quadrature Amplitude Modulation (QAM) with more than 1 bit per subchannel and wherein at least one data variable of the one or more data variables comprises an array representing frequency domain received idle channel noise information.

50. (Previously Presented) In a transceiver capable of receiving test information over a communication channel using multicarrier modulation comprising, a method comprising:

receiving a message, wherein the message comprises one or more data variables that represent the test information, wherein bits in the message were modulated onto DMT symbols using Quadrature Amplitude Modulation (QAM) with more than 1 bit per subchannel and wherein at least one data variable of the one or more data variables comprises an array representing frequency domain received idle channel noise information.

51. (Previously Presented) A non-transitory computer-readable information storage media having stored thereon instructions that, if executed, cause a transceiver to perform a method comprising:

transmitting a message, wherein the message comprises one or more data variables that represent the test information, wherein bits in the message are modulated onto DMT symbols using Quadrature Amplitude Modulation (QAM) with more than 1 bit per subchannel and wherein at least one data variable of the one or more data variables comprises an array representing frequency domain received idle channel noise information.

52. (Previously Presented) A non-transitory computer-readable information storage media having stored thereon instructions that, if executed, cause a transceiver to perform a method comprising:

receiving a message, wherein the message comprises one or more data variables that represent the test information, wherein bits in the message were modulated onto DMT symbols using Quadrature Amplitude Modulation (QAM) with more than 1 bit per subchannel and wherein at least one data variable of the one or more data variables comprises an array representing frequency domain received idle channel noise information.



**REMARKS**

Applicants request reconsideration of this application as amended.

Applicants would like to thank Examiner Tran for the allowance of claims 51 and 52.

Claims 47-50 were rejected on the grounds of nonstatutory obviousness-type double patenting as unpatentable over claims 1 and 9 of U.S. Patent No. 7,570,686.

In order to overcome the double patenting rejection, attached hereto is a Terminal Disclaimer to obviate the double patenting rejection of claims 47-50 over claims 1 and 9 of U.S. Patent No. 7,570,686 to Krinsky et al.

With all rejections having been overcome, Applicants respectfully submit the application is in condition for allowance. A prompt Notice of Allowance is respectfully solicited.

Should the Examiner believe anything further is desirable in order to place the application in even better condition for allowance, the Examiner is encouraged to contact Applicants undersigned representative at the telephone number listed below.

The Commissioner is hereby authorized to charge to deposit account number 19-1970 any fees under 37 CFR § 1.16 and 1.17 that may be required by this paper and to credit any overpayment to that Account. If any extension of time is required in connection with the filing of this paper and has not been separately requested, such extension is hereby petitioned.

Respectfully submitted,

SHERIDAN ROSS P.C.

Date: 17 Aug '10

By:   
Jason H. Vick  
Reg. No. 45,285  
1560 Broadway, Suite 1200  
Denver, Colorado 80202  
Telephone: 303-863-9700

**TERMINAL DISCLAIMER TO OBIATE A DOUBLE PATENTING  
REJECTION OVER A "PRIOR" PATENT**Docket Number (Optional)  
5550-2-CON-2-1

In re Application of: David M. Krinsky

Application No.: 12/477,742

Filed: June 3, 2009

For: MULTICARRIER MODULATION MESSAGING FOR FREQUENCY DOMAIN RECEIVED IDLE CHANNEL NOISE INFORMATION

The owner\*, AWARE, INC, of 100 percent interest in the instant application hereby disclaims, except as provided below, the terminal part of the statutory term of any patent granted on the instant application which would extend beyond the expiration date of the full statutory term **prior patent** No. 7,570,686 as the term of said prior patent is defined in 35 U.S.C. 154 and 173, and as the term of said **prior patent** is presently shortened by any terminal disclaimer. The owner hereby agrees that any patent so granted on the instant application shall be enforceable only for and during such period that it and the **prior patent** are commonly owned. This agreement runs with any patent granted on the instant application and is binding upon the grantee, its successors or assigns.

In making the above disclaimer, the owner does not disclaim the terminal part of the term of any patent granted on the instant application that would extend to the expiration date of the full statutory term as defined in 35 U.S.C. 154 and 173 of the **prior patent**, "as the term of said **prior patent** is presently shortened by any terminal disclaimer," in the event that said **prior patent** later:

- expires for failure to pay a maintenance fee;
- is held unenforceable;
- is found invalid by a court of competent jurisdiction;
- is statutorily disclaimed in whole or terminally disclaimed under 37 CFR 1.321;
- has all claims canceled by a reexamination certificate;
- is reissued; or
- is in any manner terminated prior to the expiration of its full statutory term as presently shortened by any terminal disclaimer.

Check either box 1 or 2 below, if appropriate.

1.  For submissions on behalf of a business/organization (e.g., corporation, partnership, university, government agency, etc.), the undersigned is empowered to act on behalf of the business/organization.

I hereby declare that all statements made herein of my own knowledge are true and that all statements made on information and belief are believed to be true; and further that these statements were made with the knowledge that willful false statements and the like so made are punishable by fine or imprisonment, or both, under Section 1001 of Title 18 of the United States Code and that such willful false statements may jeopardize the validity of the application or any patent issued thereon.

2.  The undersigned is an attorney or agent of record. Reg. No. 45285

  
\_\_\_\_\_  
Signature

August 17, 2010  
\_\_\_\_\_  
Date

Jason H. Vick  
\_\_\_\_\_  
Typed or printed name

303-863-9700  
\_\_\_\_\_  
Telephone Number

- Terminal disclaimer fee under 37 CFR 1.20(d) included.

**WARNING: Information on this form may become public. Credit card information should not be included on this form. Provide credit card information and authorization on PTO-2038.**

\*Statement under 37 CFR 3.73(b) is required if terminal disclaimer is signed by the assignee (owner).  
Form PTO/SB/96 may be used for making this certification. See MPEP § 324.

This collection of information is required by 37 CFR 1.321. The information is required to obtain or retain a benefit by the public which is to file (and by the USPTO to process) an application. Confidentiality is governed by 35 U.S.C. 122 and 37 CFR 1.11 and 1.14. This collection is estimated to take 12 minutes to complete, including gathering, preparing, and submitting the completed application form to the USPTO. Time will vary depending upon the individual case. Any comments on the amount of time you require to complete this form and/or suggestions for reducing this burden, should be sent to the Chief Information Officer, U.S. Patent and Trademark Office, U.S. Department of Commerce, P.O. Box 1450, Alexandria, VA 22313-1450. DO NOT SEND FEES OR COMPLETED FORMS TO THIS ADDRESS. SEND TO: Commissioner for Patents, P.O. Box 1450, Alexandria, VA 22313-1450.

If you need assistance in completing the form, call 1-800-PTO-9199 and select option 2.

## Electronic Patent Application Fee Transmittal

<b>Application Number:</b>	12477742			
<b>Filing Date:</b>	03-Jun-2009			
<b>Title of Invention:</b>	SYSTEM AND METHOD FOR ESTABLISHING A DIAGNOSTIC TRANSMISSION MODE AND COMMUNICATING OVER THE SAME			
<b>First Named Inventor/Applicant Name:</b>	David M. Krinsky			
<b>Filer:</b>	Jason Vick/Joanne Vos			
<b>Attorney Docket Number:</b>	5550-2-CON-2-1			
Filed as Large Entity				
<b>Utility under 35 USC 111(a) Filing Fees</b>				
Description	Fee Code	Quantity	Amount	Sub-Total in USD(\$)
<b>Basic Filing:</b>				
<b>Pages:</b>				
<b>Claims:</b>				
<b>Miscellaneous-Filing:</b>				
<b>Petition:</b>				
<b>Patent-Appeals-and-Interference:</b>				
<b>Post-Allowance-and-Post-Issuance:</b>				
<b>Extension-of-Time:</b>				

Description	Fee Code	Quantity	Amount	Sub-Total in USD(\$)
<b>Miscellaneous:</b>				
Statutory disclaimer	1814	1	140	140
<b>Total in USD (\$)</b>				<b>140</b>

## Electronic Acknowledgement Receipt

<b>EFS ID:</b>	8237252
<b>Application Number:</b>	12477742
<b>International Application Number:</b>	
<b>Confirmation Number:</b>	8072
<b>Title of Invention:</b>	SYSTEM AND METHOD FOR ESTABLISHING A DIAGNOSTIC TRANSMISSION MODE AND COMMUNICATING OVER THE SAME
<b>First Named Inventor/Applicant Name:</b>	David M. Krinsky
<b>Customer Number:</b>	62574
<b>Filer:</b>	Jason Vick/Joanne Vos
<b>Filer Authorized By:</b>	Jason Vick
<b>Attorney Docket Number:</b>	5550-2-CON-2-1
<b>Receipt Date:</b>	17-AUG-2010
<b>Filing Date:</b>	03-JUN-2009
<b>Time Stamp:</b>	16:47:35
<b>Application Type:</b>	Utility under 35 USC 111(a)

### Payment information:

Submitted with Payment	yes
Payment Type	Deposit Account
Payment was successfully received in RAM	\$ 140
RAM confirmation Number	3394
Deposit Account	191970
Authorized User	

The Director of the USPTO is hereby authorized to charge indicated fees and credit any overpayment as follows:

Charge any Additional Fees required under 37 C.F.R. Section 1.16 (National application filing, search, and examination fees)

Charge any Additional Fees required under 37 C.F.R. Section 1.17 (Patent application and reexamination processing fees)

Charge any Additional Fees required under 37 C.F.R. Section 1.19 (Document supply fees)

Charge any Additional Fees required under 37 C.F.R. Section 1.20 (Post Issuance fees)

Charge any Additional Fees required under 37 C.F.R. Section 1.21 (Miscellaneous fees and charges)

**File Listing:**

Document Number	Document Description	File Name	File Size(Bytes)/ Message Digest	Multi Part /.zip	Pages (if appl.)
1		AMEND_02.pdf	373636 fd37388981937b2048417b41f7b5e823ad65aca	yes	5
<b>Multipart Description/PDF files in .zip description</b>					
	<b>Document Description</b>		<b>Start</b>		<b>End</b>
	Amendment/Req. Reconsideration-After Non-Final Reject		1		1
	Specification		2		2
	Claims		3		4
	Applicant Arguments/Remarks Made in an Amendment		5		5
<b>Warnings:</b>					
<b>Information:</b>					
2	Terminal Disclaimer Filed	Terminal_Disclaimer_01.pdf	137857 c4f022be926a9b9aa94645b72f8244cc83e10de4	no	1
<b>Warnings:</b>					
<b>Information:</b>					
3	Fee Worksheet (PTO-875)	fee-info.pdf	30246 6743ce73c5d6dce16c24fcc90c56836feb12d4	no	2
<b>Warnings:</b>					
<b>Information:</b>					
<b>Total Files Size (in bytes):</b>			541739		

This Acknowledgement Receipt evidences receipt on the noted date by the USPTO of the indicated documents, characterized by the applicant, and including page counts, where applicable. It serves as evidence of receipt similar to a Post Card, as described in MPEP 503.

**New Applications Under 35 U.S.C. 111**

If a new application is being filed and the application includes the necessary components for a filing date (see 37 CFR 1.53(b)-(d) and MPEP 506), a Filing Receipt (37 CFR 1.54) will be issued in due course and the date shown on this Acknowledgement Receipt will establish the filing date of the application.

**National Stage of an International Application under 35 U.S.C. 371**

If a timely submission to enter the national stage of an international application is compliant with the conditions of 35 U.S.C. 371 and other applicable requirements a Form PCT/DO/EO/903 indicating acceptance of the application as a national stage submission under 35 U.S.C. 371 will be issued in addition to the Filing Receipt, in due course.

**New International Application Filed with the USPTO as a Receiving Office**

If a new international application is being filed and the international application includes the necessary components for an international filing date (see PCT Article 11 and MPEP 1810), a Notification of the International Application Number and of the International Filing Date (Form PCT/RO/105) will be issued in due course, subject to prescriptions concerning national security, and the date shown on this Acknowledgement Receipt will establish the international filing date of the application.

Under the Paperwork Reduction Act of 1995, no persons are required to respond to a collection of information unless it displays a valid OMB control number.

<b>PATENT APPLICATION FEE DETERMINATION RECORD</b> Substitute for Form PTO-875					Application or Docket Number <b>12/477,742</b>		Filing Date <b>06/03/2009</b>		<input type="checkbox"/> To be Mailed					
<b>APPLICATION AS FILED – PART I</b>							<b>OTHER THAN</b>							
(Column 1)			(Column 2)		SMALL ENTITY <input type="checkbox"/>		OR		SMALL ENTITY					
FOR	NUMBER FILED	NUMBER EXTRA	RATE (\$)	FEE (\$)	OR		RATE (\$)	FEE (\$)						
<input type="checkbox"/> BASIC FEE <small>(37 CFR 1.16(a), (b), or (c))</small>	N/A	N/A	N/A				N/A							
<input type="checkbox"/> SEARCH FEE <small>(37 CFR 1.16(k), (j), or (m))</small>	N/A	N/A	N/A				N/A							
<input type="checkbox"/> EXAMINATION FEE <small>(37 CFR 1.16(o), (p), or (q))</small>	N/A	N/A	N/A				N/A							
TOTAL CLAIMS <small>(37 CFR 1.16(i))</small>	minus 20 =	*	X \$ =				X \$ =							
INDEPENDENT CLAIMS <small>(37 CFR 1.16(h))</small>	minus 3 =	*	X \$ =				X \$ =							
<input type="checkbox"/> APPLICATION SIZE FEE <small>(37 CFR 1.16(s))</small>	If the specification and drawings exceed 100 sheets of paper, the application size fee due is \$250 (\$125 for small entity) for each additional 50 sheets or fraction thereof. See 35 U.S.C. 41(a)(1)(G) and 37 CFR 1.16(s).													
<input type="checkbox"/> MULTIPLE DEPENDENT CLAIM PRESENT <small>(37 CFR 1.16(j))</small>														
* If the difference in column 1 is less than zero, enter "0" in column 2.														
<b>APPLICATION AS AMENDED – PART II</b>							<b>OTHER THAN</b>							
(Column 1)			(Column 2)		(Column 3)		SMALL ENTITY		OR		SMALL ENTITY			
AMENDMENT	<b>08/17/2010</b>	CLAIMS REMAINING AFTER AMENDMENT	HIGHEST NUMBER PREVIOUSLY PAID FOR	PRESENT EXTRA	RATE (\$)	ADDITIONAL FEE (\$)	OR		RATE (\$)	ADDITIONAL FEE (\$)				
	Total <small>(37 CFR 1.16(i))</small>	* 6	Minus	** 20	= 0	X \$ =			OR	X \$52=	0			
	Independent <small>(37 CFR 1.16(h))</small>	* 6	Minus	***6	= 0	X \$ =			OR	X \$220=	0			
	<input type="checkbox"/> Application Size Fee <small>(37 CFR 1.16(s))</small>													
	<input type="checkbox"/> FIRST PRESENTATION OF MULTIPLE DEPENDENT CLAIM <small>(37 CFR 1.16(j))</small>													
					TOTAL ADD'L FEE			OR	TOTAL ADD'L FEE	<b>0</b>				
(Column 1)			(Column 2)		(Column 3)		SMALL ENTITY		OR		SMALL ENTITY			
AMENDMENT	CLAIMS REMAINING AFTER AMENDMENT	HIGHEST NUMBER PREVIOUSLY PAID FOR	PRESENT EXTRA	RATE (\$)	ADDITIONAL FEE (\$)	OR		RATE (\$)	ADDITIONAL FEE (\$)					
	Total <small>(37 CFR 1.16(i))</small>	*	Minus	**	=			X \$ =	OR	X \$ =				
	Independent <small>(37 CFR 1.16(h))</small>	*	Minus	***	=			X \$ =	OR	X \$ =				
	<input type="checkbox"/> Application Size Fee <small>(37 CFR 1.16(s))</small>													
	<input type="checkbox"/> FIRST PRESENTATION OF MULTIPLE DEPENDENT CLAIM <small>(37 CFR 1.16(j))</small>													
					TOTAL ADD'L FEE			OR	TOTAL ADD'L FEE					
* If the entry in column 1 is less than the entry in column 2, write "0" in column 3.														
** If the "Highest Number Previously Paid For" IN THIS SPACE is less than 20, enter "20".														
*** If the "Highest Number Previously Paid For" IN THIS SPACE is less than 3, enter "3".														
The "Highest Number Previously Paid For" (Total or Independent) is the highest number found in the appropriate box in column 1.														
Legal Instrument Examiner: /PAMELA THERATT/														

This collection of information is required by 37 CFR 1.16. The information is required to obtain or retain a benefit by the public which is to file (and by the USPTO to process) an application. Confidentiality is governed by 35 U.S.C. 122 and 37 CFR 1.14. This collection is estimated to take 12 minutes to complete, including gathering, preparing, and submitting the completed application form to the USPTO. Time will vary depending upon the individual case. Any comments on the amount of time you require to complete this form and/or suggestions for reducing this burden, should be sent to the Chief Information Officer, U.S. Patent and Trademark Office, U.S. Department of Commerce, P.O. Box 1450, Alexandria, VA 22313-1450. DO NOT SEND FEES OR COMPLETED FORMS TO THIS ADDRESS. **SEND TO: Commissioner for Patents, P.O. Box 1450, Alexandria, VA 22313-1450.**  
 If you need assistance in completing the form, call 1-800-PTO-9199 and select option 2.





UNITED STATES PATENT AND TRADEMARK OFFICE

UNITED STATES DEPARTMENT OF COMMERCE  
United States Patent and Trademark Office  
Address: COMMISSIONER FOR PATENTS  
P.O. Box 1450  
Alexandria, Virginia 22313-1450  
www.uspto.gov

APPLICATION NO.	FILING DATE	FIRST NAMED INVENTOR	ATTORNEY DOCKET NO.	CONFIRMATION NO.
12/477,742	06/03/2009	David M. Krinsky	5550-2-CON-2-1	8072
62574	7590	08/16/2010		
Jason H. Vick Sheridan Ross, PC Suite # 1200 1560 Broadway Denver, CO 80202			EXAMINER TRAN, KHANH C	
			ART UNIT	PAPER NUMBER
			2611	
			NOTIFICATION DATE	DELIVERY MODE
			08/16/2010	ELECTRONIC

**Please find below and/or attached an Office communication concerning this application or proceeding.**

The time period for reply, if any, is set in the attached communication.

Notice of the Office communication was sent electronically on above-indicated "Notification Date" to the following e-mail address(es):

[jvick@sheridanross.com](mailto:jvick@sheridanross.com)

<b>Office Action Summary</b>	<b>Application No.</b> 12/477,742	<b>Applicant(s)</b> KRINSKY ET AL.	
	<b>Examiner</b> KHANH C. TRAN	<b>Art Unit</b> 2611	

-- The MAILING DATE of this communication appears on the cover sheet with the correspondence address --

**Period for Reply**

A SHORTENED STATUTORY PERIOD FOR REPLY IS SET TO EXPIRE 3 MONTH(S) OR THIRTY (30) DAYS, WHICHEVER IS LONGER, FROM THE MAILING DATE OF THIS COMMUNICATION.

- Extensions of time may be available under the provisions of 37 CFR 1.136(a). In no event, however, may a reply be timely filed after SIX (6) MONTHS from the mailing date of this communication.
- If NO period for reply is specified above, the maximum statutory period will apply and will expire SIX (6) MONTHS from the mailing date of this communication.
- Failure to reply within the set or extended period for reply will, by statute, cause the application to become ABANDONED (35 U.S.C. § 133). Any reply received by the Office later than three months after the mailing date of this communication, even if timely filed, may reduce any earned patent term adjustment. See 37 CFR 1.704(b).

**Status**

- 1)  Responsive to communication(s) filed on 03 June 2009.
- 2a)  This action is **FINAL**.
- 2b)  This action is non-final.
- 3)  Since this application is in condition for allowance except for formal matters, prosecution as to the merits is closed in accordance with the practice under *Ex parte Quayle*, 1935 C.D. 11, 453 O.G. 213.

**Disposition of Claims**

- 4)  Claim(s) 47-52 is/are pending in the application.
  - 4a) Of the above claim(s) \_\_\_\_\_ is/are withdrawn from consideration.
- 5)  Claim(s) 51 and 52 is/are allowed.
- 6)  Claim(s) 47-50 is/are rejected.
- 7)  Claim(s) \_\_\_\_\_ is/are objected to.
- 8)  Claim(s) \_\_\_\_\_ are subject to restriction and/or election requirement.

**Application Papers**

- 9)  The specification is objected to by the Examiner.
- 10)  The drawing(s) filed on 03 June 2009 is/are: a)  accepted or b)  objected to by the Examiner.
  - Applicant may not request that any objection to the drawing(s) be held in abeyance. See 37 CFR 1.85(a).
  - Replacement drawing sheet(s) including the correction is required if the drawing(s) is objected to. See 37 CFR 1.121(d).
- 11)  The oath or declaration is objected to by the Examiner. Note the attached Office Action or form PTO-152.

**Priority under 35 U.S.C. § 119**

- 12)  Acknowledgment is made of a claim for foreign priority under 35 U.S.C. § 119(a)-(d) or (f).
  - a)  All b)  Some \* c)  None of:
    - 1.  Certified copies of the priority documents have been received.
    - 2.  Certified copies of the priority documents have been received in Application No. \_\_\_\_\_.
    - 3.  Copies of the certified copies of the priority documents have been received in this National Stage application from the International Bureau (PCT Rule 17.2(a)).
- \* See the attached detailed Office action for a list of the certified copies not received.

**Attachment(s)**

- 1)  Notice of References Cited (PTO-892)
- 2)  Notice of Draftsperson's Patent Drawing Review (PTO-948)
- 3)  Information Disclosure Statement(s) (PTO/SB/08)  
Paper No(s)/Mail Date \_\_\_\_\_
- 4)  Interview Summary (PTO-413)  
Paper No(s)/Mail Date \_\_\_\_\_
- 5)  Notice of Informal Patent Application
- 6)  Other: \_\_\_\_\_

### **DETAILED ACTION**

1. The Amendment filed on 6/9/2010 has been entered. Claims 47-52 are still pending in this Office action.

### ***Response to Arguments***

2. Applicant's arguments, see Applicants' Remarks, filed 6/9/2010, with respect to the rejection(s) of claim(s) 52 under 35 U.S.C 101 have been fully considered and are persuasive. Therefore, the rejection has been withdrawn. However, upon further consideration, a new ground(s) of rejection is made in view of Double Patenting Rejection over U.S. Patent 7,570,686.

### ***Double Patenting***

The nonstatutory double patenting rejection is based on a judicially created doctrine grounded in public policy (a policy reflected in the statute) so as to prevent the unjustified or improper timewise extension of the "right to exclude" granted by a patent and to prevent possible harassment by multiple assignees. A nonstatutory obviousness-type double patenting rejection is appropriate where the conflicting claims are not identical, but at least one examined application claim is not patentably distinct from the reference claim(s) because the examined application claim is either anticipated by, or would have been obvious over, the reference claim(s). See, e.g., *In re Berg*, 140

F.3d 1428, 46 USPQ2d 1226 (Fed. Cir. 1998); *In re Goodman*, 11 F.3d 1046, 29 USPQ2d 2010 (Fed. Cir. 1993); *In re Longi*, 759 F.2d 887, 225 USPQ 645 (Fed. Cir. 1985); *In re Van Ornum*, 686 F.2d 937, 214 USPQ 761 (CCPA 1982); *In re Vogel*, 422 F.2d 438, 164 USPQ 619 (CCPA 1970); and *In re Thorington*, 418 F.2d 528, 163 USPQ 644 (CCPA 1969).

A timely filed terminal disclaimer in compliance with 37 CFR 1.321(c) or 1.321(d) may be used to overcome an actual or provisional rejection based on a nonstatutory double patenting ground provided the conflicting application or patent either is shown to be commonly owned with this application, or claims an invention made as a result of activities undertaken within the scope of a joint research agreement.

Effective January 1, 1994, a registered attorney or agent of record may sign a terminal disclaimer. A terminal disclaimer signed by the assignee must fully comply with 37 CFR 3.73(b).

3. Claim 47 is rejected on the ground of nonstatutory obviousness-type double patenting as being unpatentable over claim 9 of U.S. Patent No. 7,570,686. Although the conflicting claims are not identical, they are not patentably distinct from each other because the following reasons.

***Pending claim recites*** “A transceiver capable of transmitting test information over a communication channel using multicarrier modulation comprising: a transmitter portion capable of transmitting a message, wherein the message comprises one or

more data variables that represent the test information, wherein bits in the message are modulated onto DMT symbols using Quadrature Amplitude Modulation (QAM) with more than 1 bit per sub-channel and wherein at least one data variable of the one or more data variables comprises an array representing frequency domain received idle channel noise information”.

***Claim 9 of U.S. Patent No. ‘686’*** recites “A multicarrier communication transceiver capable of communicating diagnostic information over a communication channel using multicarrier modulation comprising: means for transmitting or receiving at the multicarrier communication transceiver an initiate diagnostic mode message; and means for transmitting from the multicarrier communication transceiver a diagnostic message using multicarrier modulation, wherein the diagnostic message comprises a plurality of data variables representing the diagnostic information about the communication channel and each bit in the diagnostic message is mapped to at least one DMT symbol, and wherein one variable comprises an array representing frequency domain received idle channel noise information”.

***Pending claim differs from claim 9 of U.S. Patent No. ‘686’*** in that pending claim recites “a message” instead of “diagnostic message” recited in U.S. Patent No. ‘686’; “the message comprises one or more data variables that represent the test information” instead of “the diagnostic message comprises a plurality of data variables representing the diagnostic information” as recited in U.S. Patent No. ‘686’; “at least one

Art Unit: 2611

data variable of the one or more data variables comprises an array representing frequency domain received idle channel noise information” instead of “one variable comprises an array representing frequency domain received idle channel noise information” as recited in U.S. Patent No. ‘686’. The claimed features “transmission portion” corresponds to the means for transmitting as recited in U.S. Patent No. ‘686’; and DMT symbols being modulated using QAM are inherent features as well known in the art. In view of that, pending claim is broadened in scope and an obvious variation of patented claim 9 of U.S. Patent No. ‘686’. Because of that, pending claim is rejected on the ground of nonstatutory obviousness-type double patenting as being unpatentable over claim 9 of U.S. Patent No. 7,570,686.

4. Claim 48 is also rejected on the same ground as recited in claim 47 over claim 9 of U.S. Patent No. 7,570,686 since the multicarrier communication transceiver, as recited in U.S. Patent No. ‘686’, is capable of transmitting or ***receiving*** at the multicarrier communication transceiver an initiate diagnostic mode message.

5. Claim 49 is rejected on the ground of nonstatutory obviousness-type double patenting as being unpatentable over claim 1 of U.S. Patent No. 7,570,686, using the same arguments as discussed in claim 47 rejection.

6. Claim 50 is also rejected on the same ground as recited in claim 49 over claim 1 of U.S. Patent No. 7,570,686 since the transceiver, as recited in claim 1 of U.S. Patent

Art Unit: 2611

No. 7,570,686, capable of transmitting or receiving at the multicarrier communication transceiver an initiate diagnostic mode message.

***Allowable Subject Matter***

7. Claims 51-52 are allowed.

***Conclusion***

8. The prior art made of record and not relied upon is considered pertinent to applicant's disclosure.

Liang et al. U.S. Patent 6,445,773 B1.

KOrkosz et al. U.S. Patent 6,781,513 B1.

9. Any inquiry concerning this communication or earlier communications from the examiner should be directed to KHANH C. TRAN whose telephone number is (571)272-3007. The examiner can normally be reached on Monday - Friday from 08:00 AM - 05:00 PM.

If attempts to reach the examiner by telephone are unsuccessful, the examiner's supervisor, Shuwang Liu can be reached on 571-272-3036. The fax phone number for the organization where this application or proceeding is assigned is 571-273-8300.

Information regarding the status of an application may be obtained from the Patent Application Information Retrieval (PAIR) system. Status information for published applications may be obtained from either Private PAIR or Public PAIR. Status information for unpublished applications is available through Private PAIR only. For more information about the PAIR system, see <http://pair-direct.uspto.gov>. Should you have questions on access to the Private PAIR system, contact the Electronic Business Center (EBC) at 866-217-9197 (toll-free). If you would like assistance from a USPTO Customer Service Representative or access to the automated information system, call 800-786-9199 (IN USA OR CANADA) or 571-272-1000.

KCT

*/KHANH C. TRAN/  
Primary Examiner, Art Unit 2611*



<b>Notice of References Cited</b>	Application/Control No. 12/477,742	Applicant(s)/Patent Under Reexamination KRINSKY ET AL.	
	Examiner KHANH C. TRAN	Art Unit 2611	Page 1 of 1

**U.S. PATENT DOCUMENTS**

*	Document Number Country Code-Number-Kind Code	Date MM-YYYY	Name	Classification
*	A US-6,445,773	09-2002	Liang et al.	379/1.04
*	B US-6,781,513	08-2004	Korkosz et al.	340/539.1
	C US-			
	D US-			
	E US-			
	F US-			
	G US-			
	H US-			
	I US-			
	J US-			
	K US-			
	L US-			
	M US-			

**FOREIGN PATENT DOCUMENTS**

*	Document Number Country Code-Number-Kind Code	Date MM-YYYY	Country	Name	Classification
	N				
	O				
	P				
	Q				
	R				
	S				
	T				

**NON-PATENT DOCUMENTS**

*	Document Number Country Code-Number-Kind Code	Date MM-YYYY	Country	Name	Classification
	Include as applicable: Author, Title Date, Publisher, Edition or Volume, Pertinent Pages)				
	U				
	V				
	W				
	X				

\*A copy of this reference is not being furnished with this Office action. (See MPEP § 707.05(a).)  
Dates in MM-YYYY format are publication dates. Classifications may be US or foreign.

<b>Index of Claims</b>  	<b>Application/Control No.</b>  12477742	<b>Applicant(s)/Patent Under Reexamination</b>  KRINSKY ET AL.
	<b>Examiner</b>  KHANH C TRAN	<b>Art Unit</b>  2611

✓	<b>Rejected</b>	-	<b>Cancelled</b>	N	<b>Non-Elected</b>	A	<b>Appeal</b>
=	<b>Allowed</b>	÷	<b>Restricted</b>	I	<b>Interference</b>	O	<b>Objected</b>

<input type="checkbox"/> Claims renumbered in the same order as presented by applicant		<input type="checkbox"/> CPA		<input type="checkbox"/> T.D.		<input type="checkbox"/> R.1.47	
CLAIM		DATE					
Final	Original	06/03/2010	08/12/2010				
	1	-	-				
	2	-	-				
	3	-	-				
	4	-	-				
	5	-	-				
	6	-	-				
	7	-	-				
	8	-	-				
	9	-	-				
	10	-	-				
	11	-	-				
	12	-	-				
	13	-	-				
	14	-	-				
	15	-	-				
	16	-	-				
	17	-	-				
	18	-	-				
	19	-	-				
	20	-	-				
	21	-	-				
	22	-	-				
	23	-	-				
	24	-	-				
	25	-	-				
	26	-	-				
	27	-	-				
	28	-	-				
	29	-	-				
	30	-	-				
	31	-	-				
	32	-	-				
	33	-	-				
	34	-	-				
	35	-	-				
	36	-	-				

<b>Index of Claims</b>  	<b>Application/Control No.</b>  12477742	<b>Applicant(s)/Patent Under Reexamination</b>  KRINSKY ET AL.
	<b>Examiner</b>  KHANH C TRAN	<b>Art Unit</b>  2611

✓	<b>Rejected</b>	-	<b>Cancelled</b>	N	<b>Non-Elected</b>	A	<b>Appeal</b>
=	<b>Allowed</b>	÷	<b>Restricted</b>	I	<b>Interference</b>	O	<b>Objected</b>

<input type="checkbox"/> Claims renumbered in the same order as presented by applicant		<input type="checkbox"/> CPA		<input type="checkbox"/> T.D.		<input type="checkbox"/> R.1.47			
CLAIM		DATE							
Final	Original	06/03/2010	08/12/2010						
	37	-	-						
	38	-	-						
	39	-	-						
	40	-	-						
	41	-	-						
	42	-	-						
	43	-	-						
	44	-	-						
	45	-	-						
	46	-	-						
	47	=	✓						
	48	=	✓						
	49	=	✓						
	50	=	✓						
	51	=	=						
	52	✓	=						

<b>Search Notes</b>  	<b>Application/Control No.</b> 12477742	<b>Applicant(s)/Patent Under Reexamination</b> KRINSKY ET AL.
	<b>Examiner</b> KHANH C TRAN	<b>Art Unit</b> 2611

<b>SEARCHED</b>			
<b>Class</b>	<b>Subclass</b>	<b>Date</b>	<b>Examiner</b>

<b>SEARCH NOTES</b>		
<b>Search Notes</b>	<b>Date</b>	<b>Examiner</b>
Update Searches on the Parent Cases US Patent 6,658,052 & US Patent 7,570,686	6/3/2010	KCT
Update EAST Searches & Double Patenting Searches	8/11/2010	KCT

<b>INTERFERENCE SEARCH</b>			
<b>Class</b>	<b>Subclass</b>	<b>Date</b>	<b>Examiner</b>

	/KHANH C TRAN/ Primary Examiner.Art Unit 2611
--	--



UNITED STATES PATENT AND TRADEMARK OFFICE

UNITED STATES DEPARTMENT OF COMMERCE  
 United States Patent and Trademark Office  
 Address: COMMISSIONER FOR PATENTS  
 P.O. Box 1450  
 Alexandria, Virginia 22313-1450  
 www.uspto.gov

BIB DATA SHEET

CONFIRMATION NO. 8072

SERIAL NUMBER	FILING or 371(c) DATE	CLASS	GROUP ART UNIT	ATTORNEY DOCKET NO.	
12/477,742	06/03/2009	375	2611	5550-2-CON-2-1	
<b>APPLICANTS</b> David M. Krinsky, Acton, MA; Robert Edmund Pizzano Jr., Stoneham, MA;					
<b>** CONTINUING DATA *****</b> This application is a CON of 10/619,691 07/16/2003 PAT 7,570,686 YES * which is a DIV of 09/755,173 01/08/2001 PAT 6,658,052 YES which claims benefit of 60/224,308 08/10/2000 YES and claims benefit of 60/174,865 01/07/2000 YES * (*) Data provided by applicant is not consistent with PTO records. → /KCT/					
<b>** FOREIGN APPLICATIONS *****</b> NO /KCT/					
<b>** IF REQUIRED, FOREIGN FILING LICENSE GRANTED **</b> 06/10/2009					
Foreign Priority claimed <input type="checkbox"/> Yes <input checked="" type="checkbox"/> No 35 USC 119(a-d) conditions met <input type="checkbox"/> Yes <input type="checkbox"/> No Verified and Acknowledged <u>/KHANH C TRAN/</u> Examiner's Signature	<input type="checkbox"/> Met after Allowance KCT Initials	<b>STATE OR COUNTRY</b> MA	<b>SHEETS DRAWINGS</b> 2	<b>TOTAL CLAIMS</b> 6 ← 3	<b>INDEPENDENT CLAIMS</b> 6 ← 3
<b>ADDRESS</b> Jason H. Vick Sheridan Ross, PC Suite # 1200 1560 Broadway Denver, CO 80202 UNITED STATES					
<b>TITLE</b> SYSTEM AND METHOD FOR ESTABLISHING A DIAGNOSTIC TRANSMISSION MODE AND COMMUNICATING OVER THE SAME					
<b>FILING FEE RECEIVED</b> 1750	FEES: Authority has been given in Paper No. _____ to charge/credit DEPOSIT ACCOUNT No. _____ for following:		<input type="checkbox"/> All Fees <input type="checkbox"/> 1.16 Fees (Filing) <input type="checkbox"/> 1.17 Fees (Processing Ext. of time) <input type="checkbox"/> 1.18 Fees (Issue) <input type="checkbox"/> Other _____ <input type="checkbox"/> Credit		

Substitute for form 1449A/PTO				<b>Complete if Known</b>	
<b>INFORMATION DISCLOSURE STATEMENT BY APPLICANT</b>				Application Number	12/477,742
				Filing Date	June 3, 2009
				First Named Inventor	David M. Krinsky
				Art Unit	2611
				Examiner Name	Khanh C. Tran
Sheet	1	of	1	Attorney Docket Number	5550-2-CON-2-1

U.S. PATENT DOCUMENTS					
Examiner Initials*	Cite No. <sup>1</sup>	Document Number Number-kind Code <sup>2 (if known)</sup>	Publication Date MM-DD-YYYY	Name of Patentee or Applicant of Cited Document	Pages, Columns, Lines, Where Relevant Passages or Relevant Figures Appear

FOREIGN PATENT DOCUMENTS						
Examiner Initials*	Cite No. <sup>1</sup>	Foreign Patent Document Country Code <sup>3</sup> ; Number <sup>4</sup> ; Kind Code <sup>5 (if known)</sup>	Publication Date MM-DD-YYYY	Name of Patentee or Applicant of Cited Document	Pages, Columns, Lines, Where Relevant Passages or Relevant Figures Appear	T <sup>6</sup>
/KCT/	1	WO 99/67890	12/29/99	PCTEL INC		

OTHER ART (Including Author, Title, Date, Pertinent Pages, etc.)		
Examiner Initials*	Cite No. <sup>1</sup>	
/KCT/	2	Official Action for European Patent Application No. EP 06022008, mailed April 23, 2010 (Attorney's Ref. No. 5550-2-PEP5)

Examiner Signature	/Khanh Tran/ (06/14/2010)	Date Considered	06/14/2010
--------------------	---------------------------	-----------------	------------

\*EXAMINER: Initial if reference is considered, whether or not citation is in conformance and not considered. Include copy of this form with next communication to applicant.

Substitute for form 1449A/PTO				<i>Complete if Known</i>	
<b>INFORMATION DISCLOSURE STATEMENT BY APPLICANT</b>				Application Number	12/477,742
				Filing Date	June 3, 2009
				First Named Inventor	David M. Krinsky
				Art Unit	2611
				Examiner Name	<del>Not yet assigned</del> KHANH C. TRAN
Sheet	1	of	4	Attorney Docket Number	5550-2-CON-2-1

U.S. PATENT DOCUMENTS					
Examiner Initials*	Cite No. <sup>1</sup>	Document Number Number-kind Code <sup>2 (if known)</sup>	Publication Date MM-DD-YYYY	Name of Patentee of Applicant of Cited Document	Pages, Columns, Lines, Where Relevant Passages or Relevant Figures Appear
↓ /KCT/	1	4385384	05/24/83	Rosbury et al.	
	2	4566100	01/21/86	Mizuno et al.	
	3	5128619	07/07/92	Bjork et al.	
	4	5361293	11/01/94	Czerwiec	
	5	5608643	03/04/97	Wichter et al.	
	6	5864602	01/26/99	Needle	
	7	5964891	10/12/99	Caswell et al.	
	8	6073179	06/06/00	Liu et al.	
	9	6075821	06/13/00	Kao et al.	
	10	6175934	01/16/01	Hershey et al.	
	11	6219378	04/17/01	Wu	
	12	6404774	06/11/02	Jenness	
	13	6411678	06/25/02	Tomlinson, Jr. et al.	
	14	6449307	09/10/02	Ishikawa et al.	
	15	6512789	01/28/03	Mirfakhraei	
	16	6631120	10/07/03	Milbrandt	
	17	6633545	10/14/03	Milbrandt	
	18	6636603	10/21/03	Milbrandt	
	19	6725176	04/20/04	Long et al.	
	20	6658052	12/02/03	Krinsky et al.	
/KCT/	21	7570686	08/04/09	Krinsky et al.	

FOREIGN PATENT DOCUMENTS						
Examiner Initials*	Cite No. <sup>1</sup>	Foreign Patent Document Country Code <sup>3</sup> ; Number <sup>4</sup> ; Kind Code <sup>5</sup> (if known)	Publication Date MM-DD-YYYY	Name of Patentee or Applicant of Cited Document	Pages, Columns, Lines, Where Relevant Passages or Relevant Figures Appear	T <sup>6</sup>
/KCT/	22	EP 0889615	01/07/99	INTEGRATED TELECOM EXPRESS		

Examiner Signature	/Khanh Tran/ (06/14/2010)	Date Considered	06/14/2010
--------------------	---------------------------	-----------------	------------

\*EXAMINER: Initial if reference is considered, whether or not citation is in conformance and not considered. Include copy of this form with next communication to applicant.

Substitute for form 1449A/PTO				<b>Complete if Known</b>	
<b>INFORMATION DISCLOSURE STATEMENT BY APPLICANT</b>				Application Number	12/477,742
				Filing Date	June 3, 2009
				First Named Inventor	David M. Krinsky
				Art Unit	2611
				Examiner Name	<del>Not yet assigned</del> KHANH C. TRAN
Sheet	2	of	4	Attorney Docket Number	5550-2-CON-2-1

/KCT/	23	GB 2303032	02/05/97	SAMSUNG ELECTRONICS CO LTD		
/KCT/	24	JP Hei6(1994)-003956	01/12/94	TELEBIT CORPORATION		(believed to correspond to WO 86/07223 disclosed herein)
/KCT/	25	JP-A-Hei10(1998)-513622	12/22/98	ADC TELECOMMUNICATIONS INC		(Translated abstract)
/KCT/	26	JP-A-Hei11(1999)-261665	09/24/99	MATSUSHITA GRAPHIC COMMUNIC		(Translated abstract)
/KCT/	27	JP-A-Hei11(1999)-317723	11/16/99	MOTOROLA INC		(Translated abstract)
/KCT/	28	JP-A-Hei11(1999)-508417	07/21/99	ERICSSON TELEFON AB L M		(Translated abstract)
/KCT/	29	WO 00/64130	10/26/00	TERADYNE INC		
/KCT/	30	WO 86/07223	12/04/86	TELEBIT CORPORATION		(believed to correspond to JP Hei6(1994)-003956 disclosed herein)
/KCT/	31	WO 97/01900	01/16/97	ERICSSON AUSTRIA AG		
/KCT/	32	WO 99/020027	04/22/99	Aware		
/KCT/	33	WO 99/26375	05/27/99	TEKTRONIX INC		
/KCT/	34	WO 99/63427	12/09/99	GTE LABORATORIES INC		

Examiner Signature	/Khanh Tran/ (06/14/2010)	Date Considered	06/14/2010
--------------------	---------------------------	-----------------	------------

\*EXAMINER: Initial if reference is considered, whether or not citation is in conformance and not considered. Include copy of this form with next communication to applicant.



Substitute for form 1449A/PTO				<b>Complete if Known</b>	
<b>INFORMATION DISCLOSURE STATEMENT BY APPLICANT</b>				Application Number	12/477,742
				Filing Date	June 3, 2009
				First Named Inventor	David M. Krinsky
				Art Unit	2611
				Examiner Name	Not yet assigned → KHANH C. TRAN
Sheet	3	of	4	Attorney Docket Number	5550-2-CON-2-1

OTHER ART (Including Author, Title, Date, Pertinent Pages, etc.)		
Examiner Initials*	Cite No. <sup>1</sup>	
/KCT/	35	Boets P. et al.: "Modeling Aspect of Transmission Line Networks" Proceedings Of The Instrumentation And Measurement Technology Conference, US, New York, IEEE, May 12, 1992, pp. 137-141, XP000343913 ISBN: 0-7803-0640-6
/KCT/	36	Cioffi, John M., ADSL Maintenance with DMT, T1E1.4 ADSL Project, Amati Communications Corporation, December 1, 1992, pages 1-14
/KCT/	37	Lewis L. et al. "Extending Trouble Ticket System to Fault Diagnostics" IEEE Network, IEEE Inc. New York, US, Nov. 1, 1993, pp. 44-51, XP 000575228
/KCT/	38	International Search Report for PCT/US01/00418 dated Jul. 16, 2001; 4 pages (5550-2-PCT)
/KCT/	39	Written Opinion for International (PCT) Patent Application No. PCT/US01/00418, completed March 9, 2002 (5550-2-PCT)
/KCT/	40	International Preliminary Examination Report for International (PCT) Patent Application No. PCT/US01/00418, completed March 9, 2002 (5550-2-PCT)
/KCT/	41	PCT International Search Report dated Oct. 9, 2002 for PCT/US01/41653 (5550-2-PCT-3)
/KCT/	42	Examiner's First Report for Australian Patent Application No. 27669/01, mailed April 2, 2004 (Attorney's Ref. No. 5550-2-PAU)
/KCT/	43	Notice of Acceptance for Australian Patent Application No. 27669/01, mailed August 6, 2004 (Attorney's Ref. No. 5550-2-PAU)
/KCT/	44	Examiner's First Report for Australian Patent Application No. 2004203321, mailed November 16, 2006 (5550-2-PAU4)
/KCT/	45	Examiner's First Report for Australian Patent Application No. 2008203520, mailed March 9, 2009 (5550-2-PAU4-DIV)
/KCT/	46	Notice of Acceptance for Australian Patent Application No. 2008203520, mailed July 9, 2009 (5550-2-PAU4-DIV)
/KCT/	47	Official Action for Canadian Patent Application No. 2,394,491, mailed November 24, 2009 (Attorney's Ref. No. 5550-2-PCA)
/KCT/	48	Official Action for European Patent Application No. 01901808.4, mailed December 1, 2004 (Attorney's Ref. No. 5550-2-PEP)

Examiner Signature	/Khanh Tran/ (06/14/2010)	Date Considered	06/14/2010
-----------------------	---------------------------	--------------------	------------

\*EXAMINER: Initial if reference is considered, whether or not citation is in conformance and not considered. Include copy of this form with next communication to applicant.

Substitute for form 1449A/PTO  <b>INFORMATION DISCLOSURE STATEMENT BY APPLICANT</b>				<i>Complete if Known</i>	
				Application Number	12/477,742
				Filing Date	June 3, 2009
				First Named Inventor	David M. Krinsky
				Art Unit	2611
				Examiner Name	Not yet assigned → KHANH C. TRAN
Sheet	4	of	4	Attorney Docket Number	5550-2-CON-2-1

/KCT/	49	Official Action for European Patent Application No. 01901808.4, mailed September 14, 2005 (Attorney's Ref. No. 5550-2-PEP)
/KCT/	50	Communication about intention to grant a European patent for European Patent Application No. 01901808.4, mailed May 15, 2006 (Attorney's Ref. No. 5550-2-PEP)
/KCT/	51	European Search Report for European Patent Application No. EP 06022008 completed January 8, 2007 (5550-2-PEP5)
/KCT/	52	Notification of Reasons (Including translation) for Refusal for Japanese Patent Application No. 2001-552611, Dispatched Date: December 7, 2009 (Attorney's Ref. No. 5550-2-PJP)
/KCT/	53	Decision to Grant Patent (including translation) For Korean Patent Application No. 10-2002-7008794, dated December 1, 2006 (Attorney's Ref. No. 5550-2-PKR)

Examiner Signature	/Khanh Tran/ (06/14/2010)	Date Considered	06/14/2010
--------------------	---------------------------	-----------------	------------

\*EXAMINER: Initial if reference is considered, whether or not citation is in conformance and not considered. Include copy of this form with next communication to applicant.

## EAST Search History

## EAST Search History (Prior Art)

Ref #	Hits	Search Query	DBs	Default Operator	Plurals	Time Stamp
S1	674	"375"/\$.CCLS. and (channel adj cod\$5) and diversity	US-PGPUB; USPAT	OR	ON	2005/09/09 09:15
S2	230	"375"/\$.CCLS. and ((channel adj cod\$5) same diversity)	US-PGPUB; USPAT	OR	ON	2007/03/27 07:06
S3	1	"6247158".pn.	US-PGPUB; USPAT	OR	ON	2005/09/08 16:58
S4	7	("4577317"   "5283780"   "5907582"   "5909439"   "5970085"   "6023492"   "6049566").PN.	US-PGPUB; USPAT; USOCR	OR	ON	2005/09/08 17:00
S5	1	"6178196".pn.	US-PGPUB; USPAT; USOCR	OR	ON	2005/09/08 17:00
S6	1	"6389063".PN.	US-PGPUB; USPAT	OR	ON	2005/09/09 09:16
S7	1	"6603807".PN.	US-PGPUB; USPAT	OR	ON	2005/09/09 09:16
S8	1	"6359926".PN.	US-PGPUB; USPAT	OR	ON	2005/09/09 09:16
S9	15	"375"/260.CCLS. and ((channel adj cod\$5) same diversity)	US-PGPUB; USPAT	OR	ON	2005/09/15 15:55
S10	1	"6178196".pn.	US-PGPUB; USPAT	OR	ON	2005/09/15 16:00
S11	1	"6693982".pn.	US-PGPUB; USPAT	OR	ON	2005/09/15 16:41
S12	0	cross adj correlated adj base adj band	US-PGPUB; USPAT	OR	ON	2006/02/24 11:01
S13	762	(cross adj correlated) near2 signal	US-PGPUB; USPAT	OR	ON	2005/09/15 16:42
S14	589	(cross adj correlated) near signal	US-PGPUB; USPAT	OR	ON	2005/09/15 16:42
S15	43	S14 with transmit\$5	US-PGPUB; USPAT	OR	ON	2005/09/15 16:50
S16	362	transmitter same diversity same delay	US-PGPUB; USPAT	OR	ON	2005/09/15 16:51
S17	3	transmitter same diversity same (delay adj path)	US-PGPUB; USPAT	OR	ON	2005/09/15 16:51

S18	1196	diversity with delay	US-PGPUB; USPAT	OR	ON	2005/09/15 17:03
S19	139	diversity same (multi adj user)	US-PGPUB; USPAT	OR	ON	2005/09/15 17:04
S20	15	diversity same (plurality adj user) same transmitter	US-PGPUB; USPAT	OR	ON	2005/09/15 17:12
S21	24	diversity same (plurality adj user) same transmission	US-PGPUB; USPAT	OR	ON	2005/09/15 17:06
S22	0	diversity same (plurality adj user) same (different adj PN)	US-PGPUB; USPAT	OR	ON	2005/09/15 17:11
S23	18	diversity same (plurality adj user) same ( PN adi code)	US-PGPUB; USPAT	OR	ON	2005/09/15 17:12
S24	0	diversity same (plurality adj user) same ( PN adj code)	US-PGPUB; USPAT	OR	ON	2005/09/15 17:12
S25	34	(plurality adj antenna) same (plurality adj user)	US-PGPUB; USPAT	OR	ON	2005/09/15 17:16
S26	17	(plurality adj antenna) same (plurality adj user) same transmi\$5	US-PGPUB; USPAT	OR	ON	2005/09/15 17:17
S27	0	(plurality adj antenna) same (distinct adj signal)	US-PGPUB; USPAT	OR	ON	2005/09/15 17:18
S28	3	(plurality adj antenna) same (different adj spread adj code)	US-PGPUB; USPAT	OR	ON	2005/09/15 17:18
S29	12	(diversity) same (different adj spread adj code)	US-PGPUB; USPAT	OR	ON	2005/09/15 17:19
S30	0	multiusers same (channel adj coder) same (plurality adj antenna)	US-PGPUB; USPAT	OR	ON	2005/09/16 14:54
S31	3	data same (channel adj coder) same (plurality adj antenna)	US-PGPUB; USPAT	OR	ON	2005/09/16 14:54
S32	1	MIMO same (channel adj coder) same (plurality adj antenna)	US-PGPUB; USPAT	OR	ON	2005/09/16 15:03
S33	3	(MIMO same (channel adj coder)) and (plurality adj antenna)	US-PGPUB; USPAT	OR	ON	2005/09/16 14:56
S34	86	multi adj user adj data	US-PGPUB; USPAT	OR	ON	2005/09/16 14:58

S35	2	S34 and mimo	US-PGPUB; USPAT	OR	ON	2005/09/16 14:56
S36	10	S34 and diversity	US-PGPUB; USPAT	OR	ON	2005/09/16 14:57
S37	0	S34 and (seial adj parallel)	US-PGPUB; USPAT	OR	ON	2005/09/16 14:58
S38	0	S34 and (serial adj parallel)	US-PGPUB; USPAT	OR	ON	2005/09/16 14:58
S39	194399	data same channel coder same (plurality adj antenna)	US-PGPUB; USPAT	OR	ON	2005/09/16 14:59
S40	3	data same (channel adj coder) same (plurality adj antenna)	US-PGPUB; USPAT	OR	ON	2005/09/16 14:59
S41	8	data same (coder) same (plurality adj antenna)	US-PGPUB; USPAT	OR	ON	2005/09/16 15:00
S42	31	data and (channel adj coder) and (plurality adj antenna)	US-PGPUB; USPAT	OR	ON	2005/09/16 15:01
S43	3	(channel adj coder) same MIMO	US-PGPUB; USPAT	OR	ON	2005/09/16 15:02
S44	5	(channel adj coder) same (plurality adj antenna)	US-PGPUB; USPAT	OR	ON	2005/09/16 15:03
S45	66	(encoder) same (plurality adj antenna)	US-PGPUB; USPAT	OR	ON	2005/09/16 15:16
S46	5	"6285720"	US-PGPUB; USPAT	OR	ON	2005/09/16 15:06
S47	13	"375"/\$.ccls. and (multi adj user adj data)	US-PGPUB; USPAT	OR	ON	2005/09/16 15:19
S48	48	"375"/\$.ccls. and ((multi adj user) same TDMA)	US-PGPUB; USPAT	OR	ON	2005/09/16 15:20
S49	9	"375"/\$.ccls. and ((multi adj user) same FDD)	US-PGPUB; USPAT	OR	ON	2005/09/16 15:21
S50	10	"370"/\$.ccls. and ((multi adj user) same FDD)	US-PGPUB; USPAT	OR	ON	2005/09/16 15:22
S51	1	"370"/\$.ccls. and ((channel adj encoder) same FDD)	US-PGPUB; USPAT	OR	ON	2005/09/16 15:24
S52	0	"370"/\$.ccls. and ((channel adj coder) same FDD)	US-PGPUB; USPAT	OR	ON	2005/09/16 15:24
S53	1	((channel adj coder) same FDD)	US-PGPUB; USPAT	OR	ON	2005/09/16 15:24

S54	0	((channel adj coder) same (multi adj user))	US-PGPUB; USPAT	OR	ON	2005/09/16 15:24
S55	1	((channel adj encoder) same (multi adj user))	US-PGPUB; USPAT	OR	ON	2005/09/16 15:26
S56	16	((spatial adj diversity) same (multi adj user))	US-PGPUB; USPAT	OR	ON	2005/09/16 15:27
S57	99	((spatial adj diversity) and (multi adj user))	US-PGPUB; USPAT	OR	ON	2005/09/16 15:36
S58	3	"6359864"	US-PGPUB; USPAT	OR	ON	2005/09/16 15:31
S59	106	((FDD and CDMA) and (multi adj user))	US-PGPUB; USPAT	OR	ON	2005/09/16 15:31
S60	11	((spatial adj diversity) and (channel adj coder))	US-PGPUB; USPAT	OR	ON	2005/09/16 15:36
S61	5	"5321725"   "5784417"   "6031474"   "6088408"   "6473878").PN.	US-PGPUB; USPAT; USOCR	OR	ON	2005/09/16 15:48
S62	38154	data adj source	US-PGPUB; USPAT; USOCR	OR	ON	2005/09/16 15:48
S63	19	S62 with (multi adj user)	US-PGPUB; USPAT; USOCR	OR	ON	2005/09/16 15:53
S64	3	(frequency adj division adj duplex) same (multi adj user) same CDMA	US-PGPUB; USPAT; USOCR	OR	ON	2005/09/16 15:51
S65	5	"5559723"   "5905946"   "5933457"   "6161209"   "6615024").PN.	US-PGPUB; USPAT; USOCR	OR	ON	2005/09/16 15:52
S66	0	(multi adj user adj source)	US-PGPUB; USPAT; USOCR	OR	ON	2005/09/16 15:53
S67	25	((multi adj user) near2 source)	US-PGPUB; USPAT; USOCR	OR	ON	2005/09/16 15:53
S68	23266	((multi adj user) near2 source) amd MIMO	US-PGPUB; USPAT; USOCR	OR	ON	2005/09/16 15:53
S69	0	((multi adj user) near2 source) and MIMO	US-PGPUB; USPAT; USOCR	OR	ON	2005/09/16 15:55
S70	1	"6693982".pn.	US-PGPUB; USPAT; USOCR	OR	ON	2005/09/16 16:11
S71	1	"5886967".pn.	US-PGPUB; USPAT; USOCR	OR	ON	2005/09/16 16:11
S72	1	"5886987".pn.	US-PGPUB; USPAT; USOCR	OR	ON	2005/09/16 16:13
S73	6	(information adj source) near2 (different adj source)	US-PGPUB; USPAT; USOCR	OR	ON	2005/09/16 16:13

S74	323	"375"/\$.ccls. and (multiple adj access adj interference)	US-PGPUB; USPAT; USOCR	OR	ON	2005/09/16 16:14
S75	32	"375"/\$.ccls. and (multiple adj access adj interference) and (demultiplex\$5)	US-PGPUB; USPAT; USOCR	OR	ON	2005/09/16 16:16
S76	7	"375"/\$.ccls. and (multiple adj access adj interference) and (demultiplex\$5) and coder	US-PGPUB; USPAT; USOCR	OR	ON	2005/09/16 16:14
S77	28	"375"/\$.ccls. and (multiple adj channel) and (channel adj coder)	US-PGPUB; USPAT; USOCR	OR	ON	2005/09/16 16:16
S78	1	"6741658".pn.	US-PGPUB; USPAT	OR	ON	2005/09/18 08:43
S79	1	"6898248".pn.	US-PGPUB; USPAT	OR	ON	2005/09/18 08:44
S80	1	"6359864".pn.	US-PGPUB; USPAT	OR	ON	2006/02/21 10:50
S81	1	"6310923".pn.	US-PGPUB; USPAT	OR	ON	2006/02/21 10:50
S82	3	375/267.ccls. and (transmit near (different adj information))	US-PGPUB; USPAT	OR	ON	2006/02/24 13:52
S83	1	"6693982".pn.	US-PGPUB; USPAT	OR	ON	2006/02/24 15:16
S84	561	mapper with identif\$8	US-PGPUB; USPAT	OR	ON	2006/02/24 15:16
S85	71	"375"/\$.ccls. and (mapper with identif\$8)	US-PGPUB; USPAT	OR	ON	2006/02/24 15:16
S86	1	"6693982".pn.	US-PGPUB; USPAT	OR	ON	2006/02/27 09:36
S87	171	space adj time adj block adj code	US-PGPUB; USPAT	OR	ON	2006/02/27 13:37
S88	25	S87 and (spread adj spectrum)	US-PGPUB; USPAT	OR	ON	2006/02/27 10:11
S89	2	S87 and (spread adj code)	US-PGPUB; USPAT	OR	ON	2006/02/27 09:36
S90	126	(angle adj diversity)	US-PGPUB; USPAT	OR	ON	2006/02/27 10:12
S91	0	S87 and S90	US-PGPUB; USPAT	OR	ON	2006/02/27 10:11
S92	155	space adj time adj diversity	US-PGPUB; USPAT	OR	ON	2006/02/27 10:12
S93	3	S90 and S92	US-PGPUB; USPAT	OR	ON	2006/02/27 10:12

S94	3	(angle adj diversity) same (fading adj channel)	US-PGPUB; USPAT	OR	ON	2006/02/27 10:17
S95	1	(angle adj diversity) same (directed adj antenna adj beam)	US-PGPUB; USPAT	OR	ON	2006/02/27 10:17
S96	1	((plurality adj antenna) same (code adj rate) same adapt\$8)	US-PGPUB; USPAT	OR	ON	2006/02/27 10:54
S97	4	((plurality adj antenna) same (code adj rate)) and adapt\$8	US-PGPUB; USPAT	OR	ON	2006/02/27 10:55
S98	0	((plurality adj antenna) same (adapt\$8 adj code adj rate))	US-PGPUB; USPAT	OR	ON	2006/02/27 10:55
S99	0	((adaptive adj antenna) same (adapt\$8 adj code adj rate))	US-PGPUB; USPAT	OR	ON	2006/02/27 10:55
S100	0	((adaptive adj antenna) and (adapt\$8 adj code adj rate))	US-PGPUB; USPAT	OR	ON	2006/02/27 15:02
S101	94	((adaptive adj modulation) and (adaptive adj cod\$5))	US-PGPUB; USPAT	OR	ON	2006/02/27 13:11
S102	1	"5383219".pn.	US-PGPUB; USPAT	OR	ON	2006/02/27 13:36
S103	50	S87 and (transmit adj power)	US-PGPUB; USPAT	OR	ON	2006/02/27 13:43
S104	1	"6693982".pn.	US-PGPUB; USPAT	OR	ON	2006/02/27 14:05
S105	5828	channel adj estimat\$5	US-PGPUB; USPAT	OR	ON	2006/02/27 14:05
S106	1751	channel adj estimator	US-PGPUB; USPAT	OR	ON	2006/02/27 14:06
S107	48	S106 same (channel adj equalizer)	US-PGPUB; USPAT	OR	ON	2006/02/27 14:08
S108	3	S107 and (space adj time)	US-PGPUB; USPAT	OR	ON	2006/02/27 14:08
S109	7	375/267.ccls. and recod \$5	US-PGPUB; USPAT	OR	ON	2006/02/27 15:07
S110	3	("5781845"   "6067324"   "6122260").PN.	US-PGPUB; USPAT; USOCR	OR	ON	2006/02/27 15:06
S111	3	"375"/\$.ccls. and recod \$5 and (MAI)	US-PGPUB; USPAT	OR	ON	2006/02/27 15:08
S112	1	"375"/\$.ccls. and reencod\$5 and (MAI)	US-PGPUB; USPAT	OR	ON	2006/02/27 15:10
S113	7	reencod\$5 and (MAI)	US-PGPUB; USPAT	OR	ON	2006/02/27 15:08



S114	0	"375"/148.ccls. and reencod\$5 and (MAI)	US-PGPUB; USPAT	OR	ON	2006/02/27 15:14
S115	0	"375"/148.ccls. and reencod\$5 and (space adj time adj diversity)	US-PGPUB; USPAT	OR	ON	2006/02/27 15:14
S116	0	"375"/\$.ccls. and reencod\$5 and (space adj time adj diversity)	US-PGPUB; USPAT	OR	ON	2006/02/27 15:14
S117	0	"375"/\$.ccls. and reencod\$5 and ((space adj time) near2 code)	US-PGPUB; USPAT	OR	ON	2006/02/27 15:15
S118	0	"375"/\$.ccls. and reencod\$5 and ((space adj time) with code)	US-PGPUB; USPAT	OR	ON	2006/02/27 15:15
S119	7	"375"/\$.ccls. and (re adj encod\$5) and ((space adj time) with code)	US-PGPUB; USPAT	OR	ON	2006/02/27 15:15
S120	56	375/260.ccls. and Channeliz\$6	US-PGPUB; USPAT	OR	ON	2006/08/10 16:58
S121	180	375/267.ccls. and (space adj time adj cod \$8)	US-PGPUB; USPAT	OR	ON	2006/08/11 11:15
S122	1	"6366888".pn.	US-PGPUB; USPAT	OR	ON	2006/08/11 11:15
S123	3	375/267.ccls. and (non adj interleav\$8)	US-PGPUB; USPAT	OR	ON	2006/08/11 11:17
S124	11	375/260.ccls. and (non adj interleav\$8)	US-PGPUB; USPAT	OR	ON	2006/08/11 11:22
S125	0	"375"/\$.ccls. and ((inner adj cod\$5) same (outer adj cod\$6) same(non adj interleav \$8))	US-PGPUB; USPAT	OR	ON	2006/08/11 11:24
S126	2	"375"/\$.ccls. and ((inner adj cod\$5) same (outer adj cod \$6)) and(non adj interleav\$8)	US-PGPUB; USPAT	OR	ON	2006/08/11 11:24
S127	0	"375"/\$.ccls. and ((outer adj cod\$6) same (non adj interleav\$8))	US-PGPUB; USPAT	OR	ON	2006/08/11 11:25
S128	3	"375"/267.ccls. and (( cod\$6) same(non adj interleav\$8))	US-PGPUB; USPAT	OR	ON	2006/08/11 11:25
S129	2	"375"/267.ccls. and (( transmit\$5) with(non adj interleav\$8))	US-PGPUB; USPAT	OR	ON	2006/08/11 11:27

S130	4	"375"/267.ccls. and (( transmit\$5) with (without adj interleav \$8))	US-PGPUB; USPAT	OR	ON	2006/08/11 11:27
S131	180	"375"/267.ccls. and (space adj time adj cod \$6)	US-PGPUB; USPAT	OR	ON	2006/08/11 11:28
S132	1	"6115427".pn.	US-PGPUB; USPAT	OR	ON	2006/08/16 08:06
S133	1	"6693982".pn.	US-PGPUB; USPAT	OR	ON	2006/08/16 08:06
S134	3	09/393235	US-PGPUB; USPAT	OR	ON	2006/08/16 13:47
S135	353	combin\$3 with serializ \$3	US-PGPUB; USPAT	OR	ON	2006/08/16 13:48
S136	3383513	number of transmitter antennas	US-PGPUB; USPAT	OR	ON	2007/03/20 07:30
S137	1	10/184054	US-PGPUB; USPAT	OR	ON	2007/03/20 09:21
S138	1	10/619691	US-PGPUB; USPAT	OR	ON	2007/03/20 09:37
S139	1	"6636603".pn.	US-PGPUB; USPAT	OR	ON	2007/03/20 09:41
S140	1	"20040202237"	US-PGPUB; USPAT	OR	ON	2007/03/20 15:17
S141	1	09/798727	US-PGPUB; USPAT	OR	ON	2007/03/20 15:17
S142	1	"6745050".pn.	US-PGPUB; USPAT	OR	ON	2007/03/23 08:55
S143	6	("20020097779"   "4794556"   "4941178"   "5668830"   "6480557"   "RE31943").PN.	US-PGPUB; USPAT; USOCR	OR	OFF	2007/03/23 08:55
S144	695	CDMA same (multi adj user)	US-PGPUB; USPAT; USOCR	OR	OFF	2007/03/23 08:55
S145	374	"375"/\$.ccls. and (CDMA same (multi adj user))	US-PGPUB; USPAT; USOCR	OR	OFF	2007/03/23 08:56
S146	287	"375"/\$.ccls. and (CDMA with (multi adj user))	US-PGPUB; USPAT; USOCR	OR	OFF	2007/03/23 08:56
S147	0	"375"/\$.ccls. and (CDMA with (multi adj user)) and (interference adj cancel\$&)	US-PGPUB; USPAT; USOCR	OR	OFF	2007/03/23 08:57

S148	89	"375"/\$.ccls. and (CDMA with (multi adj user)) and (interference adj cancel\$5)	US-PGPUB; USPAT; USOCR	OR	OFF	2007/03/23 08:57
S149	8	"4134071"   "4744093"   "5136612"   "5164959"   "5361219"   "5363403"   "5481533"   "5790590").PN.	US-PGPUB; USPAT; USOCR	OR	OFF	2007/03/23 08:58
S150	14	("5956333").URPN.	USPAT	OR	OFF	2007/03/23 09:01
S151	1	09/326222.app.	US-PGPUB; USPAT; DERWENT; IBM_TDB	OR	OFF	2007/03/23 09:01
S152	11	"4124818"   "4992798"   "5418814"   "5467368"   "5566165"   "5596600"   "5724378"   "5956333"   "6032026"   "6088383"   "6229857").PN.	US-PGPUB; USPAT; USOCR	OR	OFF	2007/03/23 09:03
S153	11	"375"/\$.ccls. and (multi adj user adj demodul \$8)	US-PGPUB; USPAT; USOCR	OR	OFF	2007/03/27 11:53
S154	0	"375"/\$.ccls. and (multi adj user ) and remodult \$6	US-PGPUB; USPAT; USOCR	OR	OFF	2007/03/23 09:09
S155	23	"375"/\$.ccls. and (multi adj user ) and remodulat\$6	US-PGPUB; USPAT; USOCR	OR	OFF	2007/03/23 09:05
S156	0	"370"/\$.ccls. and (multi adj user ) and remodult \$6	US-PGPUB; USPAT; USOCR	OR	OFF	2007/03/23 09:09
S157	0	"455"/\$.ccls. and (multi adj user ) and remodult \$6	US-PGPUB; USPAT; USOCR	OR	OFF	2007/03/23 09:10
S158	0	"455"/\$.ccls. and ( user ) and remodult\$6	US-PGPUB; USPAT; USOCR	OR	OFF	2007/03/23 09:10
S159	237	"455"/\$.ccls. and ( user ) and remodulat \$6	US-PGPUB; USPAT; USOCR	OR	OFF	2007/03/23 09:10
S160	10	"455"/\$.ccls. and ( multiuser ) and remodulat\$6	US-PGPUB; USPAT; USOCR	OR	OFF	2007/03/23 09:11
S161	30	( multiuser ) and remodulat\$6 and CDMA	US-PGPUB; USPAT; USOCR	OR	OFF	2007/03/23 09:14
S162	873	( multiuser ) and CDMA	US-PGPUB; USPAT; USOCR	OR	OFF	2007/03/23 09:14

S163	523	"375"/\$.ccls. and (multiuser) and CDMA	US-PGPUB; USPAT; USOCR	OR	OFF	2007/03/23 09:14
S164	299	"375"/\$.ccls. and ((multiuser) same CDMA)	US-PGPUB; USPAT; USOCR	OR	OFF	2007/03/23 09:14
S165	1	"5956333".pn.	US-PGPUB; USPAT	OR	ON	2007/03/26 09:23
S166	1	"5644592".pn.	US-PGPUB; USPAT	OR	ON	2007/03/26 09:30
S167	1	10/184054	US-PGPUB; USPAT	OR	ON	2007/03/26 10:06
S168	1	"6115427".pn.	US-PGPUB; USPAT	OR	ON	2007/03/26 10:28
S169	49	375/267.ccls. and (multiuser)	US-PGPUB; USPAT	OR	ON	2007/03/26 10:32
S170	6	375/260.ccls. and (multiuser same diversity)	US-PGPUB; USPAT	OR	ON	2007/03/26 10:33
S171	2	375/295.ccls. and (multiuser same diversity)	US-PGPUB; USPAT	OR	ON	2007/03/26 10:34
S172	8	375/130.ccls. and (multiuser same diversity)	US-PGPUB; USPAT	OR	ON	2007/03/26 10:38
S173	1	375/299.ccls. and (multiuser same diversity)	US-PGPUB; USPAT	OR	ON	2007/03/26 10:35
S174	16	375/299.ccls. and (multiuser)	US-PGPUB; USPAT	OR	ON	2007/03/26 10:35
S175	41	375/130.ccls. and (multiuser)	US-PGPUB; USPAT	OR	ON	2007/03/26 10:38
S176	13	375/130.ccls. and (multiuser and PN)	US-PGPUB; USPAT	OR	ON	2007/03/26 10:40
S177	355	375/299.ccls.	US-PGPUB; USPAT	OR	ON	2007/03/26 10:40
S178	167	375/299.ccls. and user	US-PGPUB; USPAT	OR	ON	2007/03/26 10:40
S179	10	375/299.ccls. and (user same PN)	US-PGPUB; USPAT	OR	ON	2007/03/26 10:53
S180	708	"375"/\$.ccls. and (multi adj user) and CDMA	US-PGPUB; USPAT	OR	ON	2007/03/26 10:54
S181	294	"375"/\$.ccls. and (multi adj user) and CDMA and diversity	US-PGPUB; USPAT	OR	ON	2007/03/26 10:54
S182	19	"375"/\$.ccls. and ((multi adj user) same CDMA same diversity)	US-PGPUB; USPAT	OR	ON	2007/03/26 10:59

S183	14	"455"/\$.ccls. and ((multi adj user) same CDMA same diversity)	US-PGPUB; USPAT	OR	ON	2007/03/26 11:03
S184	134	"375"/267.ccls. and ((user) same CDMA )	US-PGPUB; USPAT	OR	ON	2007/03/26 11:18
S185	0	"375"/267.ccls. and (variable near3 rate) same (number adj antenna)	US-PGPUB; USPAT	OR	ON	2007/03/26 11:19
S186	9	"375"/267.ccls. and (variable near3 rate) and (number adj antenna)	US-PGPUB; USPAT	OR	ON	2007/03/26 11:19
S187	7	"375"/\$.ccls. and (variable near3 rate) and (number adj antenna) and (variable adj coding adj rate)	US-PGPUB; USPAT	OR	ON	2007/03/26 11:34
S188	1	"6349216".pn.	US-PGPUB; USPAT	OR	ON	2007/03/26 11:35
S189	53	"4041395"   "4147985"   "4165493"   "4348644"   "4356458"   "4370622"   "4442407"   "4546313"   "4647871"   "4827219"   "4890062"   "4924191"   "4985686"   "4990866"   "4994757"   "5060294"   "5101172"   "5113414"   "5119040"   "5170496"   "5195045"   "5220276"   "5251330"   "5251331"   "5276912"   "5278997"   "5300894"   "5302914"   "5329244"   "5339041"   "5351016"   "5361403"   "5408691"   "5420536"   "5428828"   "5483680"   "5553318"   "5564086"   "5589796"   "5598127"   "5640691"   "5673001"   "5694433"   "5742201"   "5880633"   "5901346"   "5905407"   "5907797"   "6020787"   "6069525"   "6141541"   "6160449"	US-PGPUB; USPAT; USOCR	OR	OFF	2007/03/26 13:31

		"6166598").PN.				
S190	1	"6947491".pn.	US-PGPUB; USPAT; USOCR	OR	OFF	2007/03/26 14:03
S191	188	(code adj rate) and (increas\$5 with antenna)	US-PGPUB; USPAT; USOCR	OR	OFF	2007/03/26 14:04
S192	6	(code adj rate) same (increas\$5 with antenna)	US-PGPUB; USPAT; USOCR	OR	OFF	2007/03/26 15:23
S193	243	375/267.ccls. and (close loop adj power adj control)	US-PGPUB; USPAT; USOCR	OR	OFF	2007/03/26 15:23
S194	1986913	375/267.ccls. and multiuser (close loop adj power adj control)	US-PGPUB; USPAT; USOCR	OR	OFF	2007/03/26 15:24
S195	7	375/267.ccls. and multiuser and (close loop adj power adj control)	US-PGPUB; USPAT; USOCR	OR	OFF	2007/03/26 15:24
S196	0	375/267.ccls. and multiuser and (close\$2 adj loop adj power adj control)	US-PGPUB; USPAT; USOCR	OR	OFF	2007/03/26 15:25
S197	1	"6115406".pn.	US-PGPUB; USPAT; USOCR	OR	OFF	2007/03/26 15:25
S198	6	("4901307"   "5652764"   "5886987"   "5952968"   "5982327"   "5991332").PN.	US-PGPUB; USPAT; USOCR	OR	OFF	2007/03/26 15:31
S199	13	("4835790"   "5267262"   "5347535"   "5412686"   "5485486"   "5548835"   "5559789"   "5574983"   "5581547"   "5590409"   "5598404"   "5604766"   "5646937").PN.	US-PGPUB; USPAT; USOCR	OR	OFF	2007/03/26 15:45
S200	26	("5886987").URPN.	USPAT	OR	OFF	2007/03/26 15:47
S201	13	("4835790"   "5267262"   "5347535"   "5412686"   "5485486"   "5548835"   "5559789"   "5574983"   "5581547"   "5590409"   "5598404"   "5604766"   "5646937").PN.	US-PGPUB; USPAT; USOCR	OR	OFF	2007/03/26 15:57
S202	5	"375"/267.OCLS. and (MIMO and (MAI))	US-PGPUB; USPAT	OR	ON	2007/03/27 07:06

S203	7	"375"/260.CCLS. and (MIMO and (MAI))	US-PGPUB; USPAT	OR	ON	2007/03/27 07:07
S204	30	"375"/\$.CCLS. and (MIMO and (MAI))	US-PGPUB; USPAT	OR	ON	2007/03/27 07:08
S205	18	"370"/\$.CCLS. and (MIMO and (MAI))	US-PGPUB; USPAT	OR	ON	2007/03/27 07:09
S206	7	"455"/\$.CCLS. and (MIMO and (MAI))	US-PGPUB; USPAT	OR	ON	2007/03/27 07:09
S207	10	"455"/\$.CCLS. and (OFDM and (MAI))	US-PGPUB; USPAT	OR	ON	2007/03/27 07:12
S208	39	"370"/\$.CCLS. and (OFDM and (MAI))	US-PGPUB; USPAT	OR	ON	2007/03/27 07:10
S209	39	"375"/\$.CCLS. and (OFDM and (MAI))	US-PGPUB; USPAT	OR	ON	2007/03/27 08:04
S210	1	"6115427".pn.	US-PGPUB; USPAT	OR	ON	2007/03/27 08:05
S211	81	(code adj rate) same (number near antenna)	US-PGPUB; USPAT	OR	ON	2007/03/27 08:20
S212	1	"6560295".pn.	US-PGPUB; USPAT	OR	ON	2007/03/27 08:52
S213	387	(space adj time) same CDMA	US-PGPUB; USPAT	OR	ON	2007/03/27 08:53
S214	68	375/267.ccls. and ((space adj time) same CDMA)	US-PGPUB; USPAT	OR	ON	2007/03/27 09:15
S215	2	375/267.ccls. and (compar\$8 with uplink with downlink)	US-PGPUB; USPAT	OR	ON	2007/03/27 09:16
S216	1	375/222.ccls. and (compar\$8 with uplink with downlink)	US-PGPUB; USPAT	OR	ON	2007/03/27 09:21
S217	0	375/222.ccls. and ((compar\$8 with uplink with downlink) same interference)	US-PGPUB; USPAT	OR	ON	2007/03/27 09:21
S218	9	"375"/\$.ccls. and ((compar\$8 with uplink with downlink) same interference)	US-PGPUB; USPAT	OR	ON	2007/03/27 09:22
S219	0	"375"/222.ccls. and (diagnostic adj bit)	US-PGPUB; USPAT; USOCR	OR	OFF	2007/03/27 11:54
S220	0	"375"/222.ccls. and (diagnostic adj tone)	US-PGPUB; USPAT; USOCR	OR	OFF	2007/03/27 11:54
S221	0	"370"/\$.ccls. and (diagnostic adj tone)	US-PGPUB; USPAT; USOCR	OR	OFF	2007/03/27 13:14
S222	19	"370"/\$.ccls. and (diagnostic with tone)	US-PGPUB; USPAT; USOCR	OR	OFF	2007/03/27 13:17
S223	0	375/222.ccls. and (diagnostic adj tone)	US-PGPUB; USPAT	OR	ON	2007/03/27 13:19

S224	0	375/222.ccls. and (diagnostic with tone)	US-PGPUB; USPAT	OR	ON	2007/03/27 13:19
S225	22	375/222.ccls. and (diagnostic with bit)	US-PGPUB; USPAT	OR	ON	2007/03/27 13:26
S226	8	"5889856"   "6137839"   "6263016"   "6374288"   "6400759"   "6442195"   "6477595"   "6594306").PN.	US-PGPUB; USPAT; USOCR	OR	OFF	2007/03/27 13:22
S227	0	375/222.ccls. and (diagnostic with DMT )	US-PGPUB; USPAT	OR	ON	2007/03/27 13:43
S228	0	"375"/\$.ccls. and (diagnostic with DMT )	US-PGPUB; USPAT	OR	ON	2007/03/27 13:26
S229	0	"370"/\$.ccls. and (diagnostic with DMT )	US-PGPUB; USPAT	OR	ON	2007/03/27 13:26
S230	0	"370"/\$.ccls. and (diagnostic same DMT )	US-PGPUB; USPAT	OR	ON	2007/03/27 13:27
S231	1	"375"/\$.ccls. and (diagnostic same DMT )	US-PGPUB; USPAT	OR	ON	2007/03/27 13:39
S232	113	"375"/\$.ccls. and (diagnostic same message)	US-PGPUB; USPAT	OR	ON	2007/03/27 13:39
S233	4	"375"/\$.ccls. and (diagnostic same message) and DMT	US-PGPUB; USPAT	OR	ON	2007/03/27 13:41
S234	6	"370"/\$.ccls. and (diagnostic same message) and DMT	US-PGPUB; USPAT	OR	ON	2007/03/27 13:42
S235	0	"370"/\$.ccls. and (diagnostic same DMT)	US-PGPUB; USPAT	OR	ON	2007/03/27 13:42
S236	1	"375"/\$.ccls. and (diagnostic same DMT)	US-PGPUB; USPAT	OR	ON	2007/03/27 13:45
S237	15	(diagnostic same DMT)	US-PGPUB; USPAT	OR	ON	2007/03/27 13:43
S238	1	375/222.ccls. and (diagnostic adj message)	US-PGPUB; USPAT	OR	ON	2007/03/27 13:43
S239	0	375/260.ccls. and (diagnostic adj message) and DMT	US-PGPUB; USPAT	OR	ON	2007/03/27 13:44
S240	0	375/260.ccls. and (diagnostic adj message)	US-PGPUB; USPAT	OR	ON	2007/03/27 13:44
S241	21	375/260.ccls. and (diagnostic )	US-PGPUB; USPAT	OR	ON	2007/03/27 13:44
S242	5	375/260.ccls. and (diagnostic ) and DMT	US-PGPUB; USPAT	OR	ON	2007/03/27 13:45



S243	5	375/260.ccls. and (diagnostic ) and OFDM	US-PGPUB; USPAT	OR	ON	2007/03/27 13:45
S244	1	"379"/\$.ccls. and (diagnostic same DMT)	US-PGPUB; USPAT	OR	ON	2007/03/27 13:45
S245	5	"379"/\$.ccls. and (diagnostic same bins)	US-PGPUB; USPAT	OR	ON	2007/03/27 13:46
S246	3	"375"/\$.ccls. and (diagnostic same bins)	US-PGPUB; USPAT	OR	ON	2007/03/27 13:46
S247	12	"370"/\$.ccls. and (diagnostic same bins)	US-PGPUB; USPAT	OR	ON	2007/03/27 13:47
S248	3	"370"/\$.ccls. and (bit with diagnostic ) and DMT	US-PGPUB; USPAT	OR	ON	2007/03/27 13:48
S249	7	"375"/\$.ccls. and (bit with diagnostic ) and DMT	US-PGPUB; USPAT	OR	ON	2007/03/27 13:50
S250	0	"702"/\$.ccls. and (bit with diagnostic ) and DMT	US-PGPUB; USPAT	OR	ON	2007/03/27 13:50
S251	0	"370"/249.ccls. and (bit with diagnostic ) and DMT	US-PGPUB; USPAT	OR	ON	2007/03/27 13:52
S252	0	"370"/249.ccls. and ( diagnostic ) and DMT	US-PGPUB; USPAT	OR	ON	2007/03/27 13:52
S253	65	"370"/249.ccls. and ( diagnostic )	US-PGPUB; USPAT	OR	ON	2007/03/27 13:52
S254	1	"370"/249.ccls. and ( diagnostic adj message )	US-PGPUB; USPAT	OR	ON	2007/03/27 13:52
S255	1	"370"/249.ccls. and ( initiat\$5 near2 diagnostic )	US-PGPUB; USPAT	OR	ON	2007/03/27 14:37
S256	0	diagnostic same (DMT adj symbol)	US-PGPUB; USPAT	OR	ON	2007/03/27 14:37
S257	0	diagnostic same (DMT adj symbol)	US-PGPUB; USPAT	OR	ON	2007/03/27 14:37
S258	0	"375"/\$.ccls. and (diagnostic same (DMT adj symbol))	US-PGPUB; USPAT	OR	ON	2007/03/27 14:37
S259	9	"375"/\$.ccls. and (diagnostic and (DMT adj symbol))	US-PGPUB; USPAT	OR	ON	2007/03/27 14:57
S260	1	"375"/\$.ccls. and (diagnostic same DMT )	US-PGPUB; USPAT	OR	ON	2007/03/27 14:58
S261	19	"375"/\$.ccls. and (bit near2 diagnostic )	US-PGPUB; USPAT	OR	ON	2007/03/27 15:00
S262	1	"375"/\$.ccls. and (map \$5 with (bit near2 diagnostic )	US-PGPUB; USPAT	OR	ON	2007/03/27 15:00

S263	12	"4566100"   "5128619"   "5608643"   "5864602"   "5964891"   "6075821"   "6188717"   "6219378"   "6404774"   "6411678"   "6449307"   "6512789").PN.	US-PGPUB; USPAT; USOCR	OR	OFF	2007/03/27 15:07
S264	0	map\$7 with diagnostic with DMT	US-PGPUB; USPAT; USOCR	OR	OFF	2007/03/27 15:08
S265	0	map\$7 with diagnostic with DMT	US-PGPUB; USPAT; IBM_TDB	OR	OFF	2007/03/27 15:09
S266	0	map\$7 with (diagnostic adj bit) with DMT	US-PGPUB; USPAT; IBM_TDB	OR	OFF	2007/03/27 15:09
S267	1	375/260.ccls. and DMT and diagnostic	US-PGPUB; USPAT; IBM_TDB	OR	OFF	2007/03/27 15:13
S268	13	375/222.ccls. and DMT and diagnostic	US-PGPUB; USPAT; IBM_TDB	OR	OFF	2007/03/27 15:10
S269	0	375/260.ccls. and (diagnostic adj bit)	US-PGPUB; USPAT; IBM_TDB	OR	OFF	2007/03/27 15:13
S270	1	"375"/\$.ccls. and (diagnostic adj bit)	US-PGPUB; USPAT; IBM_TDB	OR	OFF	2007/03/27 15:13
S271	1	"379"/\$.ccls. and (diagnostic adj bit)	US-PGPUB; USPAT; IBM_TDB	OR	OFF	2007/03/27 15:14
S272	69	(diagnostic adj bit)	US-PGPUB; USPAT; IBM_TDB	OR	OFF	2007/03/27 15:15
S273	0	(diagnostic adj bit) and DMT	US-PGPUB; USPAT; IBM_TDB	OR	OFF	2007/03/27 15:14
S274	0	(diagnostic adj bit) and multicarrier	US-PGPUB; USPAT; IBM_TDB	OR	OFF	2007/03/27 15:14
S275	0	(diagnostic adj meassage) and (DMT adj symbol)	US-PGPUB; USPAT; IBM_TDB	OR	OFF	2007/03/27 15:16
S276	1	(diagnostic adj message) and (DMT adj symbol)	US-PGPUB; USPAT; IBM_TDB	OR	OFF	2007/03/27 16:15
S277	4	10/127164	US-PGPUB; USPAT; IBM_TDB	OR	OFF	2007/03/27 16:15

S278	44	"20020006169"   "20020191709"   "20030067995"   "3898566"   "4878232"   "5163181"   "5228055"   "5249201"   "5490172"   "5493587"   "5579342"   "5608760"   "5621762"   "5636247"   "5638404"   "5651028"   "5727026"   "5751705"   "5805640"   "5822360"   "5930678"   "5991262"   "6009090"   "6032029"   "6041081"   "6125103"   "6128351"   "6130918"   "6175551"   "6222873"   "6229995"   "6236864"   "6240141"   "6246725"   "6294956"   "6356606"   "6449302"   "6504862"   "6687511"   "6701163"   "6931053"   "6931079"   "6931239"   "6931240").PN.	US-PGPUB; USPAT; USOCR	OR	OFF	2007/03/27 16:19
S279	1	"5930678".pn.	US-PGPUB; USPAT; USOCR	OR	OFF	2007/03/27 16:19
S280	0	(diagnostic adj DMT)	US-PGPUB; USPAT	OR	ON	2007/03/28 07:37
S281	29	(diagnostic adj tone)	US-PGPUB; USPAT	OR	ON	2007/03/28 07:37
S282	0	"375"/\$.ccls. and (diagnostic adj tone)	US-PGPUB; USPAT	OR	ON	2007/03/28 07:37
S283	0	"375"/\$.ccls. and (diagnostic near tone)	US-PGPUB; USPAT	OR	ON	2007/03/28 07:37
S284	7	"375"/\$.ccls. and (diagnostic near bits)	US-PGPUB; USPAT	OR	ON	2007/03/28 07:38
S285	0	"375"/\$.ccls. and (diagnos\$6 near DMT)	US-PGPUB; USPAT	OR	ON	2007/03/28 07:38
S286	0	"375"/\$.ccls. and (diagnos\$6 with DMT)	US-PGPUB; USPAT	OR	ON	2007/03/28 07:38
S287	479	"375"/\$.ccls. and (bit with DMT)	US-PGPUB; USPAT	OR	ON	2007/03/28 07:39
S288	207	"375"/\$.ccls. and (bit near3 DMT)	US-PGPUB; USPAT	OR	ON	2007/03/28 07:39

S289	13	"375"/\$.ccls. and (bit near3 DMT) and diagnost\$5	US-PGPUB; USPAT	OR	ON	2007/03/28 07:47
S290	1	"375"/\$.ccls. and ( DMT same diagnost\$5)	US-PGPUB; USPAT	OR	ON	2007/03/28 07:47
S291	40	"375"/\$.ccls. and ( DMT and diagnost\$5)	US-PGPUB; USPAT	OR	ON	2007/03/28 07:49
S292	43	"375"/222.ccls. and ( diagnost\$5 near3 modem)	US-PGPUB; USPAT	OR	ON	2007/03/28 07:50
S293	10	"375"/222.ccls. and ( diagnost\$5 near3 modem) and DMT	US-PGPUB; USPAT	OR	ON	2007/03/28 07:56
S294	0	"370"/484.ccls. and ( diagnost\$5 near3 modem) and DMT	US-PGPUB; USPAT	OR	ON	2007/03/28 07:52
S295	0	"370"/484.ccls. and ( diagnost\$5 ) and DMT	US-PGPUB; USPAT	OR	ON	2007/03/28 07:52
S296	1	"370"/484.ccls. and ( diagnost\$5 )	US-PGPUB; USPAT	OR	ON	2007/03/28 07:52
S297	16	"370"/480.ccls. and ( diagnost\$5 )	US-PGPUB; USPAT	OR	ON	2007/03/28 07:52
S298	11	"375"/222.ccls. and ( diagnost\$5 adj mode)	US-PGPUB; USPAT	OR	ON	2007/03/28 08:08
S299	1	"6658052".pn.	US-PGPUB; USPAT	OR	ON	2007/03/28 08:26
S300	96171	(one adj bit)	US-PGPUB; USPAT	OR	ON	2007/03/28 08:27
S301	5	(one adj bit) with (DMT adj symbol)	US-PGPUB; USPAT	OR	ON	2007/03/28 08:28
S302	197	(bit) with (DMT adj symbol)	US-PGPUB; USPAT	OR	ON	2007/03/28 08:28
S303	27	(bit) with (DMT adj symbol) and (diagnost\$7)	US-PGPUB; USPAT	OR	ON	2007/03/28 08:30
S304	0	(bit near test\$5) with (DMT adj symbol)	US-PGPUB; USPAT	OR	ON	2007/03/28 08:31
S305	0	(diagnost near tone) and (DMT adj symbol)	US-PGPUB; USPAT	OR	ON	2007/03/28 08:31
S306	0	(diagnost\$5 near tone) and (DMT adj symbol)	US-PGPUB; USPAT	OR	ON	2007/03/28 08:31
S307	0	(diagnost\$5 near tone) and (DMT )	US-PGPUB; USPAT	OR	ON	2007/03/28 08:31
S308	0	(diagnost\$5 near carrier) and (DMT )	US-PGPUB; USPAT	OR	ON	2007/03/28 08:36
S309	5	diagnost\$5 with (DMT )	US-PGPUB; USPAT	OR	ON	2007/03/28 09:12

S310	106	(Pulse adj width adj modulat\$6) same (FSK)	US-PGPUB; USPAT	OR	ON	2007/03/28 10:04
S311	1	"6633545".pn.	US-PGPUB; USPAT	OR	ON	2007/03/28 10:48
S312	1	10/619691	US-PGPUB; USPAT	OR	ON	2007/03/28 10:48
S313	1	"6633545".pn.	US-PGPUB; USPAT	OR	ON	2007/03/29 09:09
S314	1	"6673179".pn.	US-PGPUB; USPAT	OR	ON	2007/03/29 09:09
S315	1	"6073179".pn.	US-PGPUB; USPAT	OR	ON	2007/03/29 09:10
S316	0	"375"/\$.ccls. and (diagnos\$6 same ((frequency adj domain) with (idle adj channel adj noise)))	US-PGPUB; USPAT	OR	ON	2008/05/27 09:52
S317	0	(diagnos\$6 same ((frequency adj domain) with (idle adj channel adj noise)))	US-PGPUB; USPAT	OR	ON	2008/05/27 09:52
S318	0	(diagnos\$6 and ((frequency adj domain) with (idle adj channel adj noise)))	US-PGPUB; USPAT	OR	ON	2008/05/27 09:52
S319	0	"10619691".pn.	US-PGPUB; USPAT	OR	ON	2008/05/27 10:03
S320	1	"10/619691"	US-PGPUB; USPAT	OR	ON	2008/05/27 10:03
S321	1	"10619691"	US-PGPUB; USPAT	OR	ON	2008/06/08 23:12
S322	0	"375"/\$.ccls. and ((diagnostic adj information) same (DMT adj symbol))	US-PGPUB; USPAT	OR	ON	2008/06/08 23:32
S323	0	"375"/\$.ccls. and ((diagnostic) with (DMT adj symbol))	US-PGPUB; USPAT	OR	ON	2008/06/08 23:32
S324	0	"379"/\$.ccls. and ((diagnostic) with (DMT adj symbol))	US-PGPUB; USPAT	OR	ON	2008/06/08 23:33
S325	0	"375"/\$.ccls. and ((diagnostic) with (DMT ))	US-PGPUB; USPAT	OR	ON	2008/06/08 23:33
S326	0	"375"/\$.ccls. and ((diagnostic) with (DMT ))	US-PGPUB; USPAT; DERWENT; IBM_TDB	OR	ON	2008/06/08 23:33

S327	1	"375"/\$.ccls. and ((diagnostic) same (DMT ))	US-PGPUB; USPAT; DERWENT; IBM_TDB	OR	ON	2008/06/08 23:33
S328	4	"375"/\$.ccls. and ((diagnostic) same (multicarrier))	US-PGPUB; USPAT; DERWENT; IBM_TDB	OR	ON	2008/06/08 23:34
S329	3	"375"/\$.ccls. and ((diagnostic adj information) same (multicarrier))	US-PGPUB; USPAT; DERWENT; IBM_TDB	OR	ON	2008/06/08 23:34
S330	26	"375"/222.ccls. and ((diagnostic adj information) )	US-PGPUB; USPAT; DERWENT; IBM_TDB	OR	ON	2008/06/08 23:35
S331	2	09/925509	US-PGPUB; USPAT	OR	ON	2008/06/09 07:54
S332	12	09/755173	US-PGPUB; USPAT	OR	ON	2008/06/09 07:55
S333	142	idle adj channel adj noise	US-PGPUB; USPAT	OR	ON	2008/06/09 08:08
S334	3	S333 and DMT	US-PGPUB; USPAT	OR	ON	2008/06/09 08:09
S335	2	S333 same (diagnostic)	US-PGPUB; USPAT	OR	ON	2008/06/09 08:11
S336	256150	S333 ande (diagnostic)	US-PGPUB; USPAT	OR	ON	2008/06/09 08:14
S337	20	S333 and (diagnostic)	US-PGPUB; USPAT	OR	ON	2008/06/09 08:14
S338	32	(diagnostic adj symbol)	US-PGPUB; USPAT	OR	ON	2008/06/09 08:21
S339	0	"375"/\$.ccls and (diagnostic adj symbol)	US-PGPUB; USPAT	OR	ON	2008/06/09 08:22
S340	0	"370"/\$.ccls and (diagnostic adj symbol)	US-PGPUB; USPAT	OR	ON	2008/06/09 08:22
S341	0	"370"/\$.ccls with (diagnostic adj symbol)	US-PGPUB; USPAT	OR	ON	2008/06/09 08:22
S342	0	"375"/\$.ccls with (diagnostic adj symbol)	US-PGPUB; USPAT	OR	ON	2008/06/09 08:22
S343	0	"375"/\$.ccls with (diagnostic same symbol)	US-PGPUB; USPAT	OR	ON	2008/06/09 08:22
S344	0	"370"/\$.ccls with (test adj symbol)	US-PGPUB; USPAT	OR	ON	2008/06/09 08:23
S345	0	"370"/\$.ccls with (test with symbol)	US-PGPUB; USPAT	OR	ON	2008/06/09 08:23
S346	0	"375"/\$.ccls with (test with symbol)	US-PGPUB; USPAT	OR	ON	2008/06/09 08:23

S347	0	"370"/\$.ccls with (testing with symbol)	US-PGPUB; USPAT	OR	ON	2008/06/09 08:24
S348	5	(test\$6 with (DMT adj symbol))	US-PGPUB; USPAT	OR	ON	2008/06/09 08:24
S349	0	(diagnos\$6 with (DMT adj symbol))	US-PGPUB; USPAT	OR	ON	2008/06/09 08:25
S350	0	(diagnos\$6 same (DMT adj symbol))	US-PGPUB; USPAT	OR	ON	2008/06/09 08:26
S351	646	(map\$7same (DMT adj symbol))	US-PGPUB; USPAT	OR	ON	2008/06/09 08:26
S352	0	((diagnostic) with (DMT adj symbol))	US-PGPUB; USPAT	OR	ON	2008/06/09 08:27
S353	0	((diagnostic) same (DMT adj symbol))	US-PGPUB; USPAT	OR	ON	2008/06/09 08:27
S354	9421	transmit\$7 with diagnostic	US-PGPUB; USPAT	OR	ON	2008/06/09 09:42
S355	185	"375"/\$.ccls. and (transmit\$7 with diagnostic)	US-PGPUB; USPAT	OR	ON	2008/06/09 09:42
S356	79	"375"/\$.ccls. and (transmit\$7 near3 diagnostic)	US-PGPUB; USPAT	OR	ON	2008/06/09 09:42
S357	11	"375"/222.ccls. and (diagnostic adj mode)	US-PGPUB; USPAT	OR	ON	2008/10/06 09:00
S358	4	"375"/222.ccls. and (idle adj channel adj noise)	US-PGPUB; USPAT	OR	ON	2008/10/06 09:15
S359	1	"6658052".pn.	US-PGPUB; USPAT	OR	ON	2008/10/06 09:17
S360	13	"375"/\$.ccls. and modem and (idle adj channel adj noise)	US-PGPUB; USPAT	OR	ON	2008/10/06 09:20
S361	749	(diagnostic with tone)	US-PGPUB; USPAT	OR	ON	2008/10/10 11:04
S362	0	375/222.ccls. and (diagnostic with tone)	US-PGPUB; USPAT	OR	ON	2008/10/10 11:04
S363	0	375/222.ccls. and (diagnostic adj bits)	US-PGPUB; USPAT	OR	ON	2008/10/10 11:04
S364	26	375/222.ccls. and (diagnostic with bits)	US-PGPUB; USPAT	OR	ON	2008/10/10 11:04
S365	0	375/222.ccls. and (diagnostic with DMT)	US-PGPUB; USPAT	OR	ON	2008/10/10 11:07
S366	0	375/222.ccls. and (diagnostic with tone)	US-PGPUB; USPAT	OR	ON	2008/10/10 11:07
S367	10	"375"/\$.ccls. and (diagnostic with tone)	US-PGPUB; USPAT	OR	ON	2008/10/10 11:07
S368	6	(diagnostic with DMT)	US-PGPUB; USPAT	OR	ON	2008/10/10 11:08

S369	6	375/222.ccls. and (diagnostic adj information) and DMT	US-PGPUB; USPAT	OR	ON	2008/10/10 11:09
S370	2	"20020031167"	US-PGPUB; USPAT	OR	ON	2008/10/10 14:18
S371	2	"20010047424"	US-PGPUB; USPAT	OR	ON	2008/10/10 14:21
S372	1	"6697969".pn.	US-PGPUB; USPAT	OR	ON	2008/10/10 14:50
S373	1	"6510162".pn.	US-PGPUB; USPAT	OR	ON	2008/10/10 15:10
S374	1	(upgrad\$7 adj firmware) with (cable adj modem)	US-PGPUB; USPAT	OR	ON	2008/10/10 15:26
S375	1	(upgrad\$7 adj firmware) same (cable adj modem)	US-PGPUB; USPAT	OR	ON	2008/10/10 15:27
S376	0	(upgrad\$7 adj firmware) same (CMTS and TFTP)	US-PGPUB; USPAT	OR	ON	2008/10/10 15:27
S377	1	(upgrad\$7 adj firmware) and (CMTS and TFTP)	US-PGPUB; USPAT	OR	ON	2008/10/10 15:27
S378	932	(upgrad\$7 adj firmware)	US-PGPUB; USPAT	OR	ON	2008/10/10 15:27
S379	29	(upgrad\$7 adj firmware) same modem	US-PGPUB; USPAT	OR	ON	2008/10/10 15:28
S380	1	CMTS and ((upgrad\$7 adj firmware) same modem)	US-PGPUB; USPAT	OR	ON	2008/10/10 15:29
S381	1	CMTS same (upgrad\$7 adj firmware)	US-PGPUB; USPAT	OR	ON	2008/10/10 15:43
S382	282	CMTS same (digital adj subscriber adj line)	US-PGPUB; USPAT	OR	ON	2008/10/10 15:49
S383	186	CMTS with (digital adj subscriber adj line)	US-PGPUB; USPAT	OR	ON	2008/10/10 15:49
S384	28	"375"/\$.ccls. and (idle adj channel adj noise)	US-PGPUB; USPAT	OR	ON	2008/10/13 09:07
S385	0	"375"/\$.ccls. and (diagnostic same (idle adj channel adj noise))	US-PGPUB; USPAT	OR	ON	2008/10/13 09:12
S386	3	"375"/\$.ccls. and (diagnostic and (idle adj channel adj noise))	US-PGPUB; USPAT	OR	ON	2008/10/13 09:12
S387	20	(diagnostic and (idle adj channel adj noise))	US-PGPUB; USPAT	OR	ON	2008/10/13 09:13
S388	1	(diagnostic adj message) and (idle adj channel adj noise)	US-PGPUB; USPAT	OR	ON	2008/10/13 09:15



S389	1	(diagnostic ) and (idle adj channel adj noise) and DMT	US-PGPUB; USPAT	OR	ON	2008/10/13 09:15
S390	3	(diagnostic adj mode ) and (idle adj channel adj noise)	US-PGPUB; USPAT	OR	ON	2008/10/13 09:15
S391	15	(diagnostic ) and (idle adj channel adj noise) and modem	US-PGPUB; USPAT	OR	ON	2008/10/13 09:16
S392	20	(diagnostic ) and (idle adj channel adj noise)	US-PGPUB; USPAT	OR	ON	2008/10/13 09:17
S393	1	"6631120".pn.	US-PGPUB; USPAT	OR	ON	2008/10/13 09:27
S394	1	10/619691	US-PGPUB; USPAT	OR	ON	2008/10/13 10:17
S395	12	09/755173	US-PGPUB; USPAT	OR	ON	2008/10/13 10:39
S396	0	09/597926	US-PGPUB; USPAT	OR	ON	2008/10/13 10:44
S397	1	10/619691	US-PGPUB; USPAT	OR	ON	2009/04/28 08:48
S398	1	"6658052".pn.	US-PGPUB; USPAT	OR	ON	2009/04/28 08:52
S399	1353	(diagnostic adj message)	US-PGPUB; USPAT	OR	ON	2009/04/28 08:53
S400	42	(diagnostic adj message) same variables	US-PGPUB; USPAT	OR	ON	2009/04/28 08:53
S401	0	((diagnostic adj message) same variables) and multicarrier	US-PGPUB; USPAT	OR	ON	2009/04/28 08:53
S402	0	((diagnostic adj message) same variables) and DMT	US-PGPUB; USPAT	OR	ON	2009/04/28 08:53
S403	2	((diagnostic adj message) same variables same array)	US-PGPUB; USPAT	OR	ON	2009/04/28 08:54
S404	1	"7251199".pn.	US-PGPUB; USPAT	OR	ON	2009/04/28 09:14
S405	1	11/510121	US-PGPUB; USPAT	OR	ON	2009/04/28 09:31
S406	345	(diagnostic near bits)	US-PGPUB; USPAT	OR	ON	2009/04/29 09:36
S407	0	(diagnostic near bits) same (DMT)	US-PGPUB; USPAT	OR	ON	2009/04/29 09:37
S408	1	(diagnostic near bits) and (DMT near symbol)	US-PGPUB; USPAT	OR	ON	2009/04/29 09:37

S409	1	(diagnostic near bits) same (symbol)	US-PGPUB; USPAT	OR	ON	2009/04/29 09:38
S410	0	375/222.ccls. and ((diagnostic near bits) same DMT)	US-PGPUB; USPAT	OR	ON	2009/04/29 09:39
S411	3	375/222.ccls. and ((diagnostic near bits) )	US-PGPUB; USPAT	OR	ON	2009/04/29 09:39
S412	0	375/222.ccls. and ((test near bits) with DMT)	US-PGPUB; USPAT	OR	ON	2009/04/29 09:40
S413	1	375/222.ccls. and ((pattern near bits) with DMT)	US-PGPUB; USPAT	OR	ON	2009/04/29 09:40
S414	2	375/222.ccls. and (diagnostic near message)	US-PGPUB; USPAT	OR	ON	2009/04/29 09:41
S415	13	375/222.ccls. and (diagnostic with messages)	US-PGPUB; USPAT	OR	ON	2009/04/29 09:42
S416	43	375/222.ccls. and (diagnostic with information)	US-PGPUB; USPAT	OR	ON	2009/04/29 09:47
S417	0	375/222.ccls. and ((diagnostic with information) same variables same DMT)	US-PGPUB; USPAT	OR	ON	2009/04/29 09:48
S418	3	375/222.ccls. and ((diagnostic with information) same variables )	US-PGPUB; USPAT	OR	ON	2009/04/29 09:48
S419	0	375/222.ccls. and ((diagnostic with information) same DMT)	US-PGPUB; USPAT	OR	ON	2009/04/29 09:50
S420	9	375/222.ccls. and ((diagnostic with information) and DMT)	US-PGPUB; USPAT	OR	ON	2009/04/29 09:50
S421	0	375/222.ccls. and ((diagnostic with mode) same DMT)	US-PGPUB; USPAT	OR	ON	2009/04/29 09:54
S422	4	375/222.ccls. and ((diagnostic with symbol) )	US-PGPUB; USPAT	OR	ON	2009/04/29 09:54
S423	28	375/222.ccls. and ((diagnostic with bits) )	US-PGPUB; USPAT	OR	ON	2009/04/29 09:55
S424	3	375/222.ccls. and ((diagnostic with bits) ) and (channel near noise)	US-PGPUB; USPAT	OR	ON	2009/04/29 09:55

S425	7	"375"/\$.ccls. and ((diagnostic with bits) ) and (channel near noise)	US-PGPUB; USPAT	OR	ON	2009/04/29 09:56
S426	3	"375"/\$.ccls. and ((diagnostic with symbols) ) and (channel near noise)	US-PGPUB; USPAT	OR	ON	2009/04/29 10:02
S427	3	((diagnostic with symbols) ) and (channel near noise)	US-PGPUB; USPAT	OR	ON	2009/04/29 10:03
S428	0	((diagnostic with DMT) ) and (channel near noise)	US-PGPUB; USPAT	OR	ON	2009/04/29 10:03
S429	188	((diagnostic with information) ) and (channel near noise)	US-PGPUB; USPAT	OR	ON	2009/04/29 10:03
S430	3	((diagnostic with information) ) same (channel near noise)	US-PGPUB; USPAT	OR	ON	2009/04/29 10:03
S431	0	((diagnostic with DMT) ) same (channel near noise)	US-PGPUB; USPAT	OR	ON	2009/04/29 10:04
S432	0	((diagnostic same DMT) ) same (channel near noise)	US-PGPUB; USPAT	OR	ON	2009/04/29 10:04
S433	1	"6631130".pn.	US-PGPUB; USPAT	OR	ON	2009/04/29 10:05
S434	1	"6631120".pn.	US-PGPUB; USPAT	OR	ON	2009/04/29 10:06
S435	1	"6788705".pn.	US-PGPUB; USPAT	OR	ON	2009/04/29 10:27
S436	0	(diagonostic with tone)	US-PGPUB; USPAT	OR	ON	2009/05/05 12:00
S437	781	(diagnostic with tone)	US-PGPUB; USPAT	OR	ON	2009/05/05 12:01
S438	10	"375"/\$.ccls. and (diagnostic with tone)	US-PGPUB; USPAT	OR	ON	2009/05/05 12:01
S439	158	"375"/\$.ccls. and (diagnostic with bits)	US-PGPUB; USPAT	OR	ON	2009/05/05 12:02
S440	11	"375"/\$.ccls. and ((diagnostic adj information) with bits)	US-PGPUB; USPAT	OR	ON	2009/05/05 12:02
S441	0	"375"/\$.ccls. and (map \$7 same (diagnostic adj information) same bits same tone)	US-PGPUB; USPAT	OR	ON	2009/05/05 12:10
S442	8781	"375"/\$.ccls. and (map \$7 same (diagnostic ) ssame tone)	US-PGPUB; USPAT	OR	ON	2009/05/05 12:10

S443	0	"375"/\$.ccls. and (map \$7 with (diagnostic ) with tone)	US-PGPUB; USPAT	OR	ON	2009/05/05 12:10
S444	0	"375"/\$.ccls. and (map \$7 with (diagnostic ) with DMT)	US-PGPUB; USPAT	OR	ON	2009/05/05 12:10
S445	0	(map\$7 with (diagnostic ) with DMT)	US-PGPUB; USPAT	OR	ON	2009/05/05 12:10
S446	0	(map\$7 with (test ) with DMT)	US-PGPUB; USPAT	OR	ON	2009/05/05 12:10
S447	0	((diagnostic near bits) with DMT)	US-PGPUB; USPAT	OR	ON	2009/05/05 13:10
S448	0	((diagnostic near bits) same DMT)	US-PGPUB; USPAT	OR	ON	2009/05/05 13:10
S449	2	((diagnostic with bits) same DMT)	US-PGPUB; USPAT	OR	ON	2009/05/05 13:10
S450	0	((diagnostic near bits) same tone)	US-PGPUB; USPAT	OR	ON	2009/05/05 13:11
S451	1	"6658052".pn.	US-PGPUB; USPAT	OR	ON	2009/05/05 13:24
S452	29	"375"/222.ccls. and (diagnostic adj information)	US-PGPUB; USPAT	OR	ON	2009/05/05 14:22
S453	1	10/619691	US-PGPUB; USPAT	OR	ON	2009/05/05 14:32
S454	22	(one adj bit) with DMT	US-PGPUB; USPAT	OR	ON	2009/05/05 14:39
S455	13	09/755173	US-PGPUB; USPAT	OR	ON	2009/05/05 14:51
S456	1	"6658052".pn.	US-PGPUB; USPAT	OR	ON	2009/05/05 14:51
S457	1	"6658052".pn.	US-PGPUB; USPAT	OR	ON	2009/05/07 11:23
S458	1	10/619691	US-PGPUB; USPAT	OR	ON	2009/05/07 11:33
S459	1	"6658052".pn.	US-PGPUB; USPAT	OR	ON	2009/05/08 06:38
S460	7	(diagnostic adj information) same (array) same variables	US-PGPUB; USPAT	OR	ON	2009/05/08 06:53
S461	0	"375"/\$.ccls. and ( (diagnostic adj information) same (array) same variables)	US-PGPUB; USPAT	OR	ON	2009/05/08 06:53
S462	6	"375"/\$.ccls. and ( (diagnostic adj information) same variables)	US-PGPUB; USPAT	OR	ON	2009/05/08 06:53

S463	3	"379"/\$.ccls. and ( (diagnostic adj information) same variables)	US-PGPUB; USPAT	OR	ON	2009/05/08 06:54
S464	21	"370"/\$.ccls. and ( (diagnostic adj information) same variables)	US-PGPUB; USPAT	OR	ON	2009/05/08 06:54
S465	10	"370"/\$.ccls. and ( (diagnostic adj information) same variables) and modems	US-PGPUB; USPAT	OR	ON	2009/05/08 06:55
S466	2	(message with bits with diagnostic) same DMT	US-PGPUB; USPAT	OR	ON	2010/05/27 09:45
S467	0	(message with bits with test) same DMT	US-PGPUB; USPAT	OR	ON	2010/05/27 09:46
S468	0	(message with bits with test\$6) same DMT	US-PGPUB; USPAT	OR	ON	2010/05/27 09:46
S469	9	(message with test\$6) same DMT	US-PGPUB; USPAT	OR	ON	2010/05/27 09:46
S470	5	"375"/\$.ccls. and "370"/\$.ccls. and ((test\$6 with tone) same DMT)	US-PGPUB; USPAT	OR	ON	2010/05/27 09:47
S471	11	((digital with test\$6 with tone) same DMT)	US-PGPUB; USPAT	OR	ON	2010/05/27 10:10
S472	3	"375"/\$.ccls. and "370"/\$.ccls. and ((test\$6 with bit with tone) and DMT)	US-PGPUB; USPAT	OR	ON	2010/05/27 10:11
S473	63	"375"/\$.ccls. and "370"/\$.ccls. and ((modulat\$5 with bit with tone) and DMT)	US-PGPUB; USPAT	OR	ON	2010/05/27 10:12
S474	0	"375"/\$.ccls. and "370"/\$.ccls. and ((modulat\$5 with bits with tone) and (test adj information) and DMT)	US-PGPUB; USPAT	OR	ON	2010/05/27 10:13
S475	2	"375"/\$.ccls. and "370"/\$.ccls. and ((modulat\$5 with bit with tone) and DMT) and (data near variables)	US-PGPUB; USPAT	OR	ON	2010/05/27 10:18
S476	0	"375"/\$.ccls. and "370"/\$.ccls. and ((modulat\$5 with bit with tone with (channel adj noise)) and DMT)	US-PGPUB; USPAT	OR	ON	2010/05/27 10:20

S477	1	"375"/\$.ccls. and "370"/\$.ccls. and ((modulat\$5 with bit with tone) same (channel adj noise)) and DMT	US-PGPUB; USPAT	OR	ON	2010/05/27 10:21
S478	3	((modulat\$5 with bit with tone) same (channel adj noise)) and DMT	US-PGPUB; USPAT	OR	ON	2010/05/27 10:24
S479	1	(send with (channel adj noise)) and DMT	US-PGPUB; USPAT	OR	ON	2010/05/27 10:26
S480	7	(messag\$3 with (channel adj noise)) and DMT	US-PGPUB; USPAT	OR	ON	2010/05/27 10:27
S481	4	(bits with DMT with (channel adj noise)) and DMT	US-PGPUB; USPAT	OR	ON	2010/05/27 10:28
S482	1656	message same variable same test	US-PGPUB; USPAT	OR	ON	2010/06/03 09:44
S483	3	message same variable same test same DMT	US-PGPUB; USPAT	OR	ON	2010/06/03 09:44
S484	0	message same variable same test same QAM	US-PGPUB; USPAT	OR	ON	2010/06/03 09:44
S485	19	(message same variable same test) and DMT	US-PGPUB; USPAT	OR	ON	2010/06/03 09:45
S486	1	"6658052".pn.	US-PGPUB; USPAT	OR	ON	2010/06/03 09:47
S487	1	"6445773".pn.	US-PGPUB; USPAT	OR	ON	2010/06/03 10:48
S488	1	"6075821".pn.	US-PGPUB; USPAT	OR	ON	2010/06/03 11:11
S489	1	12/477742	US-PGPUB; USPAT	OR	ON	2010/06/14 09:18
S490	1	"7570686".pn.	US-PGPUB; USPAT	OR	ON	2010/06/14 09:22
S491	1	"6658052".pn.	US-PGPUB; USPAT	OR	ON	2010/06/14 09:25
S492	18	"375"/\$.ccls. and (diagnostic near message)	US-PGPUB; USPAT	OR	ON	2010/06/14 09:38
S493	2	"375"/\$.ccls. and "379"/\$.ccls. and (diagnostic near message)	US-PGPUB; USPAT	OR	ON	2010/06/14 09:38
S494	2	DMT same (diagnostic near message)	US-PGPUB; USPAT	OR	ON	2010/06/14 09:48
S495	2	DMT and ((diagnostic near message) same (channel adj noise))	US-PGPUB; USPAT	OR	ON	2010/06/14 09:49

S496	3	DMT and ((diagnostic near message) and (channel adj noise))	US-PGPUB; USPAT	OR	ON	2010/06/14 09:49
S497	2	((diagnostic near message) same (channel adj noise))	US-PGPUB; USPAT	OR	ON	2010/06/14 10:00
S498	3	((diagnostic near message) and (channel adj noise))	US-PGPUB; USPAT	OR	ON	2010/06/14 10:02
S499	1	"6445773".pn.	US-PGPUB; USPAT	OR	ON	2010/06/14 10:29
S500	6	"375"/\$.ccls. and (message same test same DMT)	US-PGPUB; USPAT	OR	ON	2010/08/04 10:00
S501	144	"375"/\$.ccls. and (test near message)	US-PGPUB; USPAT	OR	ON	2010/08/04 10:01
S502	0	"375"/\$.ccls. and ((test near message) same DMT)	US-PGPUB; USPAT	OR	ON	2010/08/04 10:01
S503	1	"375"/\$.ccls. and ((test near message) and DMT)	US-PGPUB; USPAT	OR	ON	2010/08/04 10:01
S504	1	"6445773".pn.	US-PGPUB; USPAT	OR	ON	2010/08/04 10:11
S505	8	(DMT with tone) same (channel near noise)	US-PGPUB; USPAT	OR	ON	2010/08/04 10:18
S506	365	(tone with test with information)	US-PGPUB; USPAT	OR	ON	2010/08/04 10:21
S507	15	(tone near test near information)	US-PGPUB; USPAT	OR	ON	2010/08/04 10:21
S508	58	message with (DMT adj symbols)	US-PGPUB; USPAT	OR	ON	2010/08/04 10:30
S509	2	message with (DMT adj symbols) with (channel adj noise)	US-PGPUB; USPAT	OR	ON	2010/08/04 10:30
S510	4	message with (DMT adj symbols) with (noise)	US-PGPUB; USPAT	OR	ON	2010/08/04 10:30
S511	0	(test near2 information) with (DMT adj symbols)	US-PGPUB; USPAT	OR	ON	2010/08/04 10:32
S512	0	(test near information) with (DMT adj symbols)	US-PGPUB; USPAT	OR	ON	2010/08/04 10:32
S513	0	(test with information) with (DMT adj symbols)	US-PGPUB; USPAT	OR	ON	2010/08/04 10:32
S514	0	(test with information) with (DMT adj symbol)	US-PGPUB; USPAT	OR	ON	2010/08/04 10:32
S515	8	(test with information) with (DMT )	US-PGPUB; USPAT	OR	ON	2010/08/04 10:32
S516	1	"6658052".pn.	US-PGPUB; USPAT	OR	ON	2010/08/04 10:35

S517	0	(test near result) with (DMT adj symbols)	US-PGPUB; USPAT	OR	ON	2010/08/04 10:42
S518	0	(test near result) with (DMT adj tine)	US-PGPUB; USPAT	OR	ON	2010/08/04 10:42
S519	0	(test near result) with (DMT adj tone)	US-PGPUB; USPAT	OR	ON	2010/08/04 10:42
S520	295	(test near result) with (tones)	US-PGPUB; USPAT	OR	ON	2010/08/04 10:42
S521	25	(test near result) near (tones)	US-PGPUB; USPAT	OR	ON	2010/08/04 10:43
S522	0	DMT and ((test near result) near (tones))	US-PGPUB; USPAT	OR	ON	2010/08/04 10:43
S523	0	DMT and ((test near result) near (tone))	US-PGPUB; USPAT	OR	ON	2010/08/04 10:43
S524	8	DMT and ((test near result) with (tone))	US-PGPUB; USPAT	OR	ON	2010/08/04 10:44

**8/ 11/ 2010 10:55:53 AM**

**C:\ Documents and Settings\ ktran5\ My Documents\ EAST\ workspaces\ 12477742.wsp**



Substitute for form 1449A/PTO				<b>Complete if Known</b>	
<b>INFORMATION DISCLOSURE STATEMENT BY APPLICANT</b>				Application Number	12/477,742
				Filing Date	June 3, 2009
				First Named Inventor	David M. Krinsky
				Art Unit	2611
				Examiner Name	Khanh C. Tran
Sheet	1	of	1	Attorney Docket Number	5550-2-CON-2-1

U.S. PATENT DOCUMENTS					
Examiner Initials*	Cite No. <sup>1</sup>	Document Number Number-kind Code <sup>2</sup> (if known)	Publication Date MM-DD-YYYY	Name of Patentee or Applicant of Cited Document	Pages, Columns, Lines, Where Relevant Passages or Relevant Figures Appear

FOREIGN PATENT DOCUMENTS						
Examiner Initials*	Cite No. <sup>1</sup>	Foreign Patent Document Country Code <sup>3</sup> ; Number <sup>4</sup> ; Kind Code <sup>5</sup> (if known)	Publication Date MM-DD-YYYY	Name of Patentee or Applicant of Cited Document	Pages, Columns, Lines, Where Relevant Passages or Relevant Figures Appear	T <sup>6</sup>
	1	WO 99/67890	12/29/99	PCTEL INC		

OTHER ART (Including Author, Title, Date, Pertinent Pages, etc.)		
Examiner Initials*	Cite No. <sup>1</sup>	
	2	Official Action for European Patent Application No. EP 06022008, mailed April 23, 2010 (Attorney's Ref. No. 5550-2-PEP5)

Examiner Signature		Date Considered	
--------------------	--	-----------------	--

\*EXAMINER: Initial if reference is considered, whether or not citation is in conformance and not considered. Include copy of this form with next communication to applicant.



## INTERNATIONAL APPLICATION PUBLISHED UNDER THE PATENT COOPERATION TREATY (PCT)

<p>(51) International Patent Classification <sup>6</sup> : H04B 1/38, H04L 5/16, 27/10, 27/18</p>	<p>A1</p>	<p>(11) International Publication Number: <b>WO 99/67890</b></p> <p>(43) International Publication Date: 29 December 1999 (29.12.99)</p>
<p>(21) International Application Number: PCT/US99/13817</p> <p>(22) International Filing Date: 18 June 1999 (18.06.99)</p> <p>(30) Priority Data: 60/090,333                      23 June 1998 (23.06.98)                      US</p> <p>(71) Applicant (for all designated States except US): PC TEL, INC. [US/US]; 70 Rio Robles, San Jose, CA 95134 (US).</p> <p>(72) Inventors; and</p> <p>(75) Inventors/Applicants (for US only): GOLDSTEIN, Yuri [US/US]; 924 Bullet Hill Road, Southbury, CT 06488 (US). OKUNEV, Yuri [US/US]; 1023/B Heritage Village, Southbury, CT 06488 (US).</p> <p>(74) Agent: GORDON, David, P.; 65 Woods End Road, Stamford, CT 06905 (US).</p>	<p>(81) Designated States: AU, CA, CN, JP, KR, US, European patent (AT, BE, CH, CY, DE, DK, ES, FI, FR, GB, GR, IE, IT, LU, MC, NL, PT, SE).</p> <p><b>Published</b> <i>With international search report. Before the expiration of the time limit for amending the claims and to be republished in the event of the receipt of amendments.</i></p>	
<p>(54) Title: SPREAD SPECTRUM HANDSHAKE FOR DIGITAL SUBSCRIBER LINE TELECOMMUNICATIONS SYSTEMS</p> <p>(57) Abstract</p> <p>Handshake information for xDSL services is transmitted utilizing a spread spectrum modulated system where a plurality (n) of carrier tones (n &gt; 2) are summed and utilized as a spread spectrum carrier (SSC), and data is modulated onto the carrier (at all utilized frequencies). Preferably, phase shift keying (PSK) modulation or a variation thereof is used as the encoding/modulation technique.</p>		

**FOR THE PURPOSES OF INFORMATION ONLY**

Codes used to identify States party to the PCT on the front pages of pamphlets publishing international applications under the PCT.

AL	Albania	ES	Spain	LS	Lesotho	SI	Slovenia
AM	Armenia	FI	Finland	LT	Lithuania	SK	Slovakia
AT	Austria	FR	France	LU	Luxembourg	SN	Senegal
AU	Australia	GA	Gabon	LV	Latvia	SZ	Swaziland
AZ	Azerbaijan	GB	United Kingdom	MC	Monaco	TD	Chad
BA	Bosnia and Herzegovina	GE	Georgia	MD	Republic of Moldova	TG	Togo
BB	Barbados	GH	Ghana	MG	Madagascar	TJ	Tajikistan
BE	Belgium	GN	Guinea	MK	The former Yugoslav Republic of Macedonia	TM	Turkmenistan
BF	Burkina Faso	GR	Greece	ML	Mali	TR	Turkey
BG	Bulgaria	HU	Hungary	MN	Mongolia	TT	Trinidad and Tobago
BJ	Benin	IE	Ireland	MR	Mauritania	UA	Ukraine
BR	Brazil	IL	Israel	MW	Malawi	UG	Uganda
BY	Belarus	IS	Iceland	MX	Mexico	US	United States of America
CA	Canada	IT	Italy	NE	Niger	UZ	Uzbekistan
CF	Central African Republic	JP	Japan	NL	Netherlands	VN	Viet Nam
CG	Congo	KE	Kenya	NO	Norway	YU	Yugoslavia
CH	Switzerland	KG	Kyrgyzstan	NZ	New Zealand	ZW	Zimbabwe
CI	Côte d'Ivoire	KP	Democratic People's Republic of Korea	PL	Poland		
CM	Cameroon	KR	Republic of Korea	PT	Portugal		
CN	China	KZ	Kazakstan	RO	Romania		
CU	Cuba	LC	Saint Lucia	RU	Russian Federation		
CZ	Czech Republic	LI	Liechtenstein	SD	Sudan		
DE	Germany	LK	Sri Lanka	SE	Sweden		
DK	Denmark	LR	Liberia	SG	Singapore		
EE	Estonia						

SPREAD SPECTRUM HANDSHAKE FOR DIGITAL SUBSCRIBER LINE  
TELECOMMUNICATIONS SYSTEMS

Priority is claimed from provisional application Serial No. 60/090,333 filed June 23, 1998 which is hereby incorporated by reference in its entirety herein.

BACKGROUND OF THE INVENTION

1. Field of the Invention

The present invention relates broadly to telecommunications systems and methods. More particularly, the present invention relates to a handshake for an xDSL (Digital Subscriber Line type) modem.

2. State of the Art

Digital subscriber line (DSL) systems are a new and fast-growing data transmission service which provide significantly higher data rates than conventional V.34 and V.90 type modems. The abbreviation "xDSL" is an integrated designation for different DSL services including ADSL (asymmetric DSL), SDSL (symmetric DSL), RADSL (rate-adaptive DSL), HDSL (high speed DSL), and VDSL (very high speed DSL), UDSL (universal DSL), and their modifications such as ADSL-LITE (also known as G.lite). The xDSL services typically provide data rates of several Mbits/s downstream and several hundred Kbits/s upstream, although SDSL provides the same upstream and downstream rates. All types of DSL are based on discrete multitone (DMT) technology although they have different parameters. See, J. Makris, "DSL Services", Data Communications, April 1998, and ANSI T1.413 -1995 "Network and Customer Installation Interfaces - Asymmetrical Digital Subscriber Line (ADSL) Metallic Interface".

According to the ITU-T telecommunications standards for the xDSL services, at modem start-up a handshake procedure (called G.hs) is utilized. The requirements for G.hs are set forth in several documents such as "Proposal for G.hs Modulation

Technique and Message Protocol", ITU-T Telecommunication Standardization Sector, C1-068 Chicago, USA 6-9 April 1998, and "Handshake procedures for Digital Subscriber Line (DSL) transceivers", ITU-T Draft G.994.1 (February 3, 1999) which are both hereby incorporated by reference herein in their entireties. The main requirements of the handshake are: transmission of several tens of bytes during the handshake; signal compatibility with all types of DSL receivers; and interworking with the plain old telephone service (POTS), the integrated services digital network (ISDN), and time compression multiplexing ISDN (TCM-ISDN). Meeting these main requirements is not a trivial task because of considerable noise and cross-talk impairments, and lack of knowledge regarding the frequency characteristics of the channel, all of which is described in various papers such as: Matsushita Electric Industrial Co. Ltd, "Proposed Working Text for G.hs Based on V.8bis", ITU-Telecommunication Standardization Sector, NF-044, Nice, France, 11-14 May 1998; Matsushita Electric Industrial Co. Ltd., "Spectrum Considerations for G.hs", ITU-Telecommunications Standardization Sector, NF-045, Nice, France 11-14 May 1998; Matsushita Electric Industrial Co., Ltd., "Crosstalk Model Proposed Working Text for G.hs Test" ITU-Telecommunications Standardization Sector, NF-046, Nice, France 11-14 May 1998; NEC, "Desired Spectrum Range for G.hs under TCM-ISDN", ITU-Telecommunications Standardization Sector, NF-066, Nice, France 11-14 May 1998; and 3Com, "Proposed Spectrum and Tone Selection for G.hs", ITU-Telecommunications Standardization Sector, NF-068, Nice, France 11-14 May 1998.

More particularly, signal attenuation across lines carrying xDSL signals is a non-monotonic function of frequency, and may have several deep notches, while noise power spectral density (PSD) is also not a flat function of frequency. As a result, the signal to noise ratio (SNR) is a complex multiextremes function of frequency. Moreover, the SNR is subject to random and cyclic variations in time. For example, in the TCM-ISDN environment which includes the so-called "ping-pong mode" of up- and down-transmissions, far-end cross-talk (FEXT) and near-end

cross-talk (NEXT) interleave at a frequency of 400 Hz. Since FEXT and NEXT processes have significantly different power spectral densities, significant NEXT noise is introduced every other 1.25 milliseconds.

As set forth above, several authors have made proposals regarding G.h.s techniques. The core of these proposals has been two-tone transmission with different bit rates depending upon the noise environment. Frequency diversity is provided by bits duplication on nominal and backup carrier tones. Time diversity is provided by increasing the symbol interval (i.e., decreasing the symbol rate). These proposals have several disadvantages. First, both the nominal and backup tones may be located in notches or other frequency domain areas having a low SNR, thus rendering the handshake ineffective. Second, increasing the symbol interval may not be sufficient to account for bursty noise. For example, in the TCM-ISDN environment, the signal to noise ratio may be below an acceptable level every other 1.25 ms interval. Even if the initial symbol interval of .232 ms were to be increased by a factor of four to .928 ms as suggested by one of the authors in the art, the entire interval could be located within the 1.25 ms high noise window. In fact, even increasing the symbol interval by a factor of 8 would still only provide a final symbol interval of 1.885 ms which could be 67% covered by the low SNR area.

#### SUMMARY OF THE INVENTION

It is therefore an object of the invention to provide a handshake for an xDSL modem which meets proposed xDSL standards requirements.

It is another object of the invention to provide a handshake for an xDSL modem which has excellent frequency diversity and time diversity and provides excellent reliability.

It is a further object of the invention to provide an xDSL modem handshake which utilizes multitone signaling.

It is an additional object of the invention to provide an xDSL modem handshake which will interwork with existing telecommunications services.

Another object of the invention is to provide modems and methods for implementing the above-listed objects.

In accord with the objects of the invention, handshake information for xDSL services are transmitted utilizing a spread spectrum modulated system where a plurality (n) of carrier tones ( $n > 2$ ) are summed and utilized as a spread spectrum carrier (SSC), and data is modulated onto the carrier (at all utilized frequencies). Preferably, phase shift keying (PSK) modulation (or a variation thereof such as BPSK - binary PSK, or DBPSK - differential binary PSK) is used as the modulating technique. When the spread spectrum carrier is modulated by handshake bits according to BPSK, the SSC is transmitted with sign "+" if the handshake bit is a +1 and with sign "-" if the handshake bit is a "-1". When using DPSK, the same modulation procedure is used for differentially encoded handshake bits.

According to one preferred aspect of the invention, the handshake symbol rate (SR) is set equal to  $.8A$  symbols/msec, where A is a positive integer. In order to improve reliability, symbols are preferably repeated at least four times. According to another preferred aspect of the invention, a preamble can be provided for timing recovery purposes. Further aspects of the invention include different receiver systems, including a quasioherent receiver, an autocorrelation receiver, and a presently preferred incoherent receiver which utilizes coherent accumulation of FFT components for a DBPSK spread spectrum handshake signal.

Additional objects and advantages of the invention will become apparent to those skilled in the art upon reference to the detailed description taken in conjunction with the provided figures.

## BRIEF DESCRIPTION OF THE DRAWINGS

Fig. 1 is a block diagram of the preferred transmitter of the invention.

Fig. 2 is a diagram showing the signal structure of the preferred handshake signal of the invention.

Fig. 3a is a block diagram of an autocorrelation receiver of DBPSK signals according to the invention;

Fig. 3b is a block diagram of a quasioherent receiver of DBPSK signals according to the invention; and

Fig. 3c is a block diagram of an incoherent receiver which utilizes coherent accumulation of FFT components for a DBPSK spread spectrum handshake signal according to the invention.

## DETAILED DESCRIPTION OF THE PREFERRED EMBODIMENT

According to the invention, handshake information for xDSL services is transmitted by modulating the handshake information on a spread spectrum carrier (SSC), where the SSC is a sum of tones conventionally used by xDSL for the data transmission mode. As seen in Fig. 1, the transmitter 10 includes a phase initialization (PI) unit 15, an inverse fast Fourier transformation (IFFT) unit 20, a spread spectrum carrier (SSC) memory 25, a modulator 30, a differential encoder 35 and a block frame unit 40. In essence, the phase initialization unit 15 generates complex numbers indicating a desirable amplitude and initial phase distribution for a plurality of multitone signals. Preferably, the amplitude distribution is chosen to be flat (uniform). According to the preferred embodiment, the initial phases of different tones are generated randomly or selected specifically in order to minimize the crest-factor of the generated tones. Regardless, where DMT-style implementation is utilized, the IFFT transforms a set of complex numbers into a



set of time-domain samples which are stored in memory 25. If, for example, all or substantially all two hundred fifty-six DMT tones (such as might be utilized in ITU-T Standard G.992.2) are generated by the PI unit 15, a five hundred twelve sample set may be stored in the memory 25. Additional repetitive samples may also be stored in the memory, if desired as a prefix which can be used by the receiver to reduce distortion. If desired, the samples may be generated in other manners (e.g., without the PI and IFFT, or in another apparatus) and loaded and stored in the transmitter memory for use as described below.

While all two hundred fifty-six DMT tones may be included in the spread spectrum carrier, it should be appreciated by those skilled in the art that according to the invention, different numbers of tones (and different tones) can be used in different circumstances, provided a spread spectrum carrier is utilized. Thus, for purposes of this application, a carrier may be considered a spread spectrum carrier if three or more distinct tones are modulated together. Thus, the SSC for a down-stream connection may contain a full or partial set of down-stream tones, while the SSC for an up-stream connection could contain a full or partial set of up-stream tones. For example, a G.Lite ADSL up-stream SSC might utilize allowed tones from the set six through thirty-two (25.875 kHz... 138 kHz), while the downstream SSC might utilize allowed tones from the set thirty-three through one hundred twenty-eight (142.3125 kHz ... 552 kHz). The SSC may contain only even or odd tones to reduce the processing at the receiver.

Handshake information (as described below with reference to Fig. 2) which is to be modulated onto the spread spectrum carrier is provided to the differential encoder 35 and differentially encoded bits are written to the block frame unit 40. According to the preferred embodiment of the invention, the handshake information is provided to the differential encoder at a speed of .8 kbps, and differentially encoded 4-bit subblocks are written into registers of the block frame unit 40. Preferably, each 4-bit subblock is read four times such that

each block frame is provided to the modulator 30 with a speed of 3.2 kbps.

When no differential encoder is utilized, the modulation technique is preferably is a binary phase shift keying (BPSK). When a differential encoder is utilized, the modulation technique is preferably a differential BPSK. Regardless, the modulator 30 uses the output of the block framer unit 40 to select whether the samples stored in the memory 25 are to be transmitted as is, or inverted (i.e., multiplied by -1 or 180 degrees out of phase). The samples stored in the memory 25 are sequentially read out of the memory so that all samples are modulated (i.e., transmitted as is or inverted) at the proposed symbol rate discussed below. When BPSK is utilized, the SSC samples are transmitted with sign "+" if the handshake bit is a "+1", and transmitted with sign "-" if the handshake bit is "-1" (or vice versa). When using DBPSK, the same modulation procedure is used for differentially encoded handshake bits.

It will be appreciated by those skilled in the art that while BPSK or DBPSK modulation is preferred, other modulation techniques such as QPSK (quadrature PSK), DQPSK (differential QPSK), frequency modulation, amplitude modulation, and quadrature amplitude modulation could be utilized.

Details of the handshake which modulates the SSC is seen in Fig. 2. According to the preferred embodiment of the invention, the handshake includes a preamble and a G.hs message. The preamble comprises N subblocks of a distinct four bit sequence "1,1,1,-1" followed by four subblocks of a four bit divider sequence "-1,-1,-1,-1", followed by eight subblocks of a pseudorandom sequence (as specified). Each subblock is preferably generated at a 1.25 millisecond rate (i.e., each subblock has a duration of 1.25 ms), with bits being generated at a .3125 millisecond rate. After the preamble, the G.hs message is provided and preferably includes N blocks which are generated at a 5 millisecond rate. Each block preferably includes four subblocks of four information bits (symbols) each (b1, b2, b3, b4), with the four information bits being repeated

four times (i.e., each subblock within the block contains the same material). Each symbol carries one information bit. So each block of duration 5 milliseconds, carries four information bits with redundancy  $3/4$ . As indicated in Fig. 2, each bit of the preamble and G.hs message is preferably modulated onto a spread spectrum carrier. As discussed in more detail below, the preamble is preferably provided to permit the receiver to detect G.hs transmission, to recover the spread spectrum carrier for coherent processing, and for symbol and block synchronization (timing recovery). While the preamble is preferably modulated, an unmodulated preamble (all +1s) can be utilized.

According to the preferred embodiment of the invention, a symbol rate (SR) is set equal to  $.8$  symbols/millisecond, where  $A = 1, 2, 3, \dots$ . With the symbol rate set in this manner, an integer number of symbols will be placed within the 1.25 millisecond burst duration in the TCM-ISDN cross talk environment. Thus, when  $A=4$  (bit rate = 3200 bps), half a byte (four bits) will be transmitted within the 1.25 ms burst. When  $A=8$  (bit rate = 6400 bps), one byte will be transmitted within the 1.25 ms burst. By transmitting each symbol of the G.hs message at least four times, at least two symbol time-separated blocks will occur within the 1.25 ms high SNR FEXT areas in a TCM-ISDN cross-talk environment.

Taking into account the 400 Hz periodicity of the NEXT and FEXT cross-talk in TCM-ISDN systems, a noiseless time window may be found by calculating the correlation between N-symbol blocks delayed by 2.5 ms relative to each other. If the delayed blocks coincide with each other (i.e., they have not been corrupted by noise), the time window has a "high enough" SNR (i.e., it is "noiseless" for the purpose of the handshake) and can be used for receiving the handshake message. The structure of the preamble is particularly arranged to permit this determination.

Because the noiseless time window has a random time position relative to the transmission of the preamble and handshake message, received N-symbol blocks may be cyclically

shifted. In other words, the block frame may not correspond to the noiseless time window frame. It is therefore preferred that this shift be estimated and eliminated. According to the preferred embodiment of the invention, the cyclic shift may be estimated and eliminated by transmitting an N-symbol reference block. Thus, the preamble is provided with a series of reference blocks having the form "1,1,1,-1". It should be appreciated that any shift of the reference block will be distinct (-1,1,1,1; 1,-1,1,1; 1,1,-1,1) and detectable, and may therefore be detected and eliminated at the receiver. This pattern therefore allows for symbol synchronization and subblock synchronization.

Turning now to Figs. 3a-3c, three different receivers are shown for receiving and demodulating the handshake signal of the invention. An autocorrelation receiver 100a for DBPSK spread spectrum handshake signals is seen in Fig. 3a. The autocorrelation receiver 100a includes an autocorrelation demodulator 102a, a timing signal extractor 103a, and preferably further includes a noiseless time window (TW) determination unit 104a and a transmitted bit selection (BS) unit 106a. The autocorrelation demodulator 102a includes a delay line (DL) 110a, a multiplier 112a, a low pass filter (LPF) 114a, and a binary slicer (Sgn) 116a. Incoming SSC modulated signals are provided to the delay line 110a and the multiplier 112a. The delay  $\Delta t$  of the delay line is preferably set equal to  $1/.8A$  ms (i.e., the handshake symbol duration). Thus, the multiplier 112a multiplies the incoming signal with the delayed signal. The output is forwarded to the low pass filter 114a which is preferably provided with a frequency bandwidth  $\Delta f$  approximately equal to  $A/1.25$  kHz. For example, when using block length  $A=4$ ,  $\Delta t = 0.3125$  ms, and  $\Delta f = 3.2$  kHz. The output of the low pass filter 114a reflects the modulation function in the transmitter, and the sign function of the low pass filter output, as generated by the binary slicer 116a which compares the output to a zero threshold, corresponds to the transmitted bits.

As will be appreciated by those skilled in the art, the

autocorrelation receiver 100a calculates (at the multiplier 112a) a scalar product ( $S_n(t) * S_{n-1}(t)$ ) between a given spread spectrum signal  $S_n(t)$  and a previous spread spectrum signal  $S_{n-1}(t)$ . The binary symbol  $I_n$  received with the n-th symbol interval is therefore determined according to  $I_n = \text{sgn}(S_n(t) * S_{n-1}(t))$ .

As seen in Fig. 3a, the binary slicer 116a requires timing information which is preferably extracted from the low pass filter output by bandpass filtering of a frequency component responding to the baud (symbol) frequency. Alternatively (and also as shown in Fig. 3a), the timing information can be extracted from the incoming signal by a variety of well-known methods; e.g., as taught in Jan W. M. Bergmans, Digital Baseband Transmission and Recording, Chapters 9 and 10, "Basics of Timing Recovery", and "A Catalog of Timing Recovery Schemes", Kluwer Academic Publishers, Boston (1996) pp. 451-587.

While the autocorrelation demodulator 102a in conjunction with the timing extractor 103a suffices as a G.h.s receiver in situations which do not require carrier recovery or other special synchronization, additional circuitry can be utilized if desired. Thus, if the channel noise has a steady power spectral density, robustness can be increased by accumulating signals at the output of the low pass filter, taking into account that every symbol may be repeated several times. In addition, if the PSD is known, the spread spectrum signal may be passed through a corresponding filter (not shown) at the input of the receiver in order to emphasize components of the spread spectrum signal having a higher SNR.

In addition, and according to the preferred embodiment of the invention, where a preamble is utilized, a noiseless time window determination unit 104a can be provided to compare the signal subblocks containing N symbols and delayed relative to each other by 2.5 ms. If the delayed N bit combination coincides within a certain time window, it indicates that this

window has a sufficiently high SNR and can be used for receiving handshake bits. Regardless, the window determination unit 104 finds the time window of interest and generates an output signal indicating the time position of the desired window which is provided to the bit selection unit 106a. The demodulated bits provided at the output of the slicer during the noiseless window are also provided to the bit selection unit 106a, which determines from the bits and the window information the cyclic shift in effect. Thus, during receipt of the G.hs message, the bit selection unit 106a selects the correct portion of the received bits and eliminates the cyclic shift in the received information blocks. The bit selection unit 106a produces for output N bits every 5 milliseconds.

Turning to Fig. 3b, a quasioherent receiver 100b for DBPSK spread spectrum handshake signals is shown. The quasioherent receiver 100b includes an autocorrelation demodulator 102b, a timing signal extractor 103b, and preferably further includes a noiseless time window determination unit 104b and a transmitted bit selection unit 106b. The quasioherent demodulator 102b includes a spread spectrum recovery (SSCR) unit 111b, a multiplier 112b, a low pass filter 114b, a binary slicer 116b, a delay line 118b, and a sign multiplier 120b. Incoming SSC modulated signals are provided to the spread spectrum carrier recovery unit 111b and the multiplier 112b. The spread spectrum carrier recovery unit 111b accumulates SSC samples during the preamble and extracts a spread spectrum reference signal  $R(t)$  therefrom. The multiplier 112b multiplies the incoming signal with the output of the SSC recovery unit. The output is forwarded to the low pass filter 114b which is preferably provided with a frequency bandwidth  $\Delta f$  approximately equal to  $N/1.25$  kHz. The output of the low pass filter 114b is fed to slicer 116b which compares the output to a threshold (typically zero). The output of slicer 116b is a binary signal which is fed to the delay line 118b and to the sign multiplier 120b. The sign of the output of the sign multiplier 120b corresponds to the transmitted bits.

As will be appreciated by those skilled in the art, in the quasicohherent receiver 100b, the average unmodulated SSC, preferably extracted from the preamble by the SSC recovery unit 111b, is used as a spread spectrum reference signal  $R(t)$  for the coherent demodulation. Thus, the recovered binary symbol  $I_n = J_n * J_{n-1}$ , where  $J_n = \text{sgn}(S_n(t) * R(t))$ , and  $J_{n-1} = \text{sgn}(S_{n-1}(t) * R(t))$ . The quasicohherent receiver 100b provides excellent results, but is substantially more complicated to implement than the autocorrelation receiver 100a because of the SSC recovery unit 111b.

The functioning of the timing signal extractor 103b, and the time window determination unit 104b and bit selection unit 106b of the quasicohherent receiver 100b are substantially as described above with respect to corresponding elements of Fig. 3a.

Turning to Fig. 3c, an incoherent receiver 100c for DBPSK spread spectrum handshake signals is shown. As seen in Fig. 3c, the incoherent receiver includes a fast Fourier transform block 130, a quadrature component accumulation unit 135, a multichannel incoherent demodulator 140, a DMT accumulation unit 145, and a binary slicer 150. The FFT block 130 receives the time domain handshake signal and converts the signal into a frequency domain signal. The output of the FFT block are signals  $F_{cnkm}$  and  $F_{snkm}$  which are respectively, the real and complex parts for the k-th DMT tone at the m-th DMT symbol interval of the n-th handshake symbol. The quadrature component accumulation (QCA) unit 145 separately sums the real parts together and the imaginary parts together according to  $F_{cnk} = \sum_m F_{cnkm}$  and  $F_{snk} = \sum_m F_{snkm}$ . The outputs of the quadrature

component accumulation unit 145 are then demodulated by the incoherent demodulator 140 according to

$F_{nk} = F_{cnk} * F_{c(n-1)k} + F_{snk} * F_{s(n-1)k}$ . The outputs of the incoherent demodulator 140 are then summed over all tones k by the DMT accumulator (DMTA) 145 according to  $F_n = \sum_k F_{nk}$ . Finally, the

output of the DMT accumulator 145 is provided to the binary slicer 150 in order to compare the output  $F_n$  to a zero threshold. The decoded binary symbol  $I_n = \text{sgn}(F_n)$ .

It should be appreciated by those skilled in the art that the incoherent receiver 100c is relatively simple to implement because it is based on the use of a FFT which is already available in DMT-based systems. In addition, no frequency equalization (carrier phase recovery) is required, and the performance of the incoherent receiver 100c is nearly as good as the quasicohherent receiver 100b of Fig. 3b.

There have been described and illustrated herein methods and apparatus for implementing a spread spectrum handshake for a digital subscriber line telecommunications system. While particular embodiments of the invention have been described, it is not intended that the invention be limited thereto, as it is intended that the invention be as broad in scope as the art will allow and that the specification be read likewise. Thus, while a particular transmitter and particular receivers have been disclosed, it will be appreciated that other transmitters and receivers could be utilized, provided that the transmitter modulate a handshake signal onto a spread spectrum carrier. Thus the implementation of the transmitters and receivers will partially depend upon the encoding technique utilized (e.g., DPSK, QPSK, etc.), the results desired, and limitations or requirements of standards which might be applicable. Implementation of functions may also be accomplished in several manners. Thus, while slicers have been described for purposes of generating decoded binary signals, other apparatus well-known in the art could be utilized. Also, while a handshake sequence including a preamble and a handshake message have been described, it will be appreciated that different preambles and different handshake messages could be provided, and/or that a handshake sequence could be provided with no preamble. It will therefore be appreciated by those skilled in the art that yet other modifications could be made to the provided invention without deviating from its spirit and scope as so claimed.



We claim:

1. A digital subscriber line (DSL) type modem, comprising:
  - a transmitter having
    - a handshake generator which generates handshake signals,
    - a spread spectrum carrier generator which generates a spread spectrum carrier including at least three tones associated with DSL type modems, and
    - a modulator coupled to said handshake generator and to said spread spectrum carrier generator, said modulator modulating indications of said handshake signals onto indications of said spread spectrum carrier simultaneously.
2. A modem according to claim 1, wherein:
  - said modulator modulates said indications of said spread spectrum carrier according to one of a phase shift keying (PSK) technique, frequency modulation, amplitude modulation, and quadrature amplitude modulation.
3. A modem according to claim 2, wherein:
  - said PSK technique comprises one of binary PSK, differential binary PSK, quadrature PSK, and differential quadrature PSK.
4. A modem according to claim 1, wherein:
  - said modulator modulates said indications of said spread spectrum carrier according to differential binary phase shift keying.
5. A modem according to claim 4, wherein:
  - said spread spectrum carrier generator comprises memory which stores said indications of all said tones.
6. A modem according to claim 5, wherein:
  - said indications comprise inverse fast Fourier transform (IFFT) samples of said at least three tones.

7. A modem according to claim 6, wherein:  
said indications comprise IFFT samples of substantially all two hundred fifty-six DMT tones associates with DSL type modems.
8. A modem according to claim 1, wherein:  
said spread spectrum carrier generator comprises memory which stores said indications of all said tones.
9. A modem according to claim 8, wherein:  
said indications of all said tones comprise inverse fast Fourier transform (IFFT) samples of said at least three tones.
10. A modem according to claim 9, wherein:  
said indications of all said tones comprise IFFT samples of substantially all two hundred fifty-six DMT tones associates with DSL type modems.
11. A modem according to claim 1, wherein:  
said handshake generator comprises a differential encoder coupled to a block framer.
12. A modem according to claim 1, wherein:  
said handshake signals comprise a handshake message.
13. A modem according to claim 12, wherein:  
said handshake message includes a plurality of blocks, each block having a plurality of repeating subblocks.
14. A modem according to claim 13, wherein:  
said blocks have a 5 millisecond rate.
15. A modem according to claim 14, wherein:  
said subblocks have a 1.25 millisecond rate, and each subblock contains four bits.
16. A modem according to claim 12, wherein:  
said handshake signals further comprise a preamble.

17. A modem according to claim 16, wherein:  
said preamble comprises a plurality of repeating subblocks.
18. A modem according to claim 17, wherein:  
each said subblock has a 1.25 millisecond rate and includes four predetermined bits, said four predetermined bits selected to permit a shift in phase of said four predetermined bits to be detected.
19. A modem according to claim 17, wherein:  
said preamble further includes at least one subblock having a divider sequence, and a plurality of subblocks representing a pseudorandom sequence.
20. A modem according to claim 1, further comprising:  
a receiver having a demodulator.
21. A modem according to claim 20, wherein:  
said receiver is chosen from a group consisting of an autocorrelation receiver, a quasicohherent receiver, and an incoherent receiver.
22. A modem according to claim 21, wherein:  
said receiver is an autocorrelation receiver including a delay line which receives and delays a received handshake signal, a multiplier which multiplies said received handshake signal with an output of said delay line, a low pass filter which filters an output of the multiplier, and means for obtaining binary symbol indication from an output of said low pass filter.

23. A modem according to claim 21, wherein:

said receiver is a quasicohherent receiver including a spread spectrum carrier recovery unit generates a reference spread spectrum signal from the received signal, a multiplier which multiplies a received signal with said reference signal, a low pass filter which filters an output of the multiplier, and means for obtaining a binary symbol indication from an output of said low pass filter.

24. A modem according to claim 23, wherein:

said means for obtaining a binary symbol indication comprises a slicer coupled to an output of said low pass filter, a delay line which receives and delays outputs of said slicer, and a second multiplier which receives an output of said slicer and an output of said delay line and generates a binary symbol indication therefrom.

25. A modem according to claim 21, wherein:

said receiver is an incoherent receiver including a fast Fourier transformer (FFT) which receives an incoming time domain handshake signal and generates real and imaginary frequency domain signals therefrom, a quadrature component accumulation (QCA) unit coupled to said FFT which separately sums said real frequency domain signals together and said imaginary frequency domain signals together, an incoherent demodulator coupled to said QCA unit which combines said summed real and imaginary frequency domain signals, a discrete multitone accumulator (DMTA) coupled to said QCA unit which sums outputs of said QCA unit over said at least three tones, and means for generating a decoded binary symbol from an output of said DMTA.

26. A modem according to claim 20, wherein:

said handshake signals comprise a handshake message and a preamble, said preamble comprises a plurality of repeating subblocks, wherein said receiver includes means for utilizing said repeating subblocks to find a high-signal-to-noise time window.

27. A modem according to claim 26, wherein  
said means for utilizing said repeating subblocks includes  
means for correlation of said repeating subblocks delayed  
relative to each other by a predetermined time interval.
28. A method of transmitting digital subscriber line (DSL) type  
modem handshake information, comprising:  
generating handshake signals; and  
modulating indications of said handshake signals onto a spread  
spectrum carrier, said spread spectrum carrier including at  
least three tones associated with DSL type modems, wherein said  
modulating comprises modulating said indications of said  
handshake signals onto indications of said at least three tones  
simultaneously.
29. A method according to claim 28, wherein:  
said handshake signal indications are modulated onto said  
spread spectrum carrier according to one of a phase shift keying  
(PSK) technique, frequency modulation, amplitude modulation, and  
quadrature amplitude modulation.
30. A method according to claim 29, wherein:  
said PSK technique comprises one of binary PSK,  
differential binary PSK, quadrature PSK, and differential  
quadrature PSK.
31. A method according to claim 28, wherein:  
said handshake signal indications are modulated onto said  
spread spectrum carrier according to differential binary phase  
shift keying.
32. A method according to claim 28, further comprising:  
generating said indications by taking an inverse fast  
Fourier transform (IFFT) of said at least three tones; and  
storing said indications in memory, wherein said modulating  
comprises reading said indications from memory in order to  
modulate said indications of said handshake signals onto said  
indications stored in memory.

33. A method according to claim 28, wherein:  
said handshake signals comprise a handshake message, said handshake message including a plurality of blocks, each block having a plurality of repeating subblocks.
34. A method according to claim 33, wherein:  
said blocks have a 5 millisecond rate, said subblocks have a 1.25 millisecond rate, and each subblock contains four bits.
35. A method according to claim 33, wherein:  
said handshake signals further comprise a preamble.
36. A method according to claim 33, wherein:  
said preamble comprises a plurality of repeating subblocks, each said subblock has a 1.25 millisecond rate and includes four predetermined bits, said four predetermined bits selected to permit a shift in phase of said four predetermined bits to be detected.
37. A method according to claim 36, wherein:  
said preamble further includes at least one subblock having a divider sequence, and a plurality of subblocks representing a pseudorandom sequence.

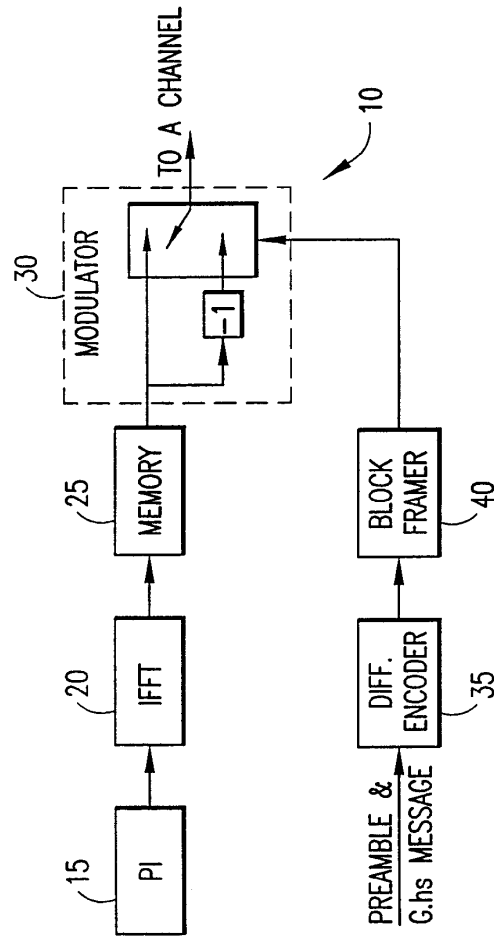

FIG.1

SUBSTITUTE SHEET (RULE 26)

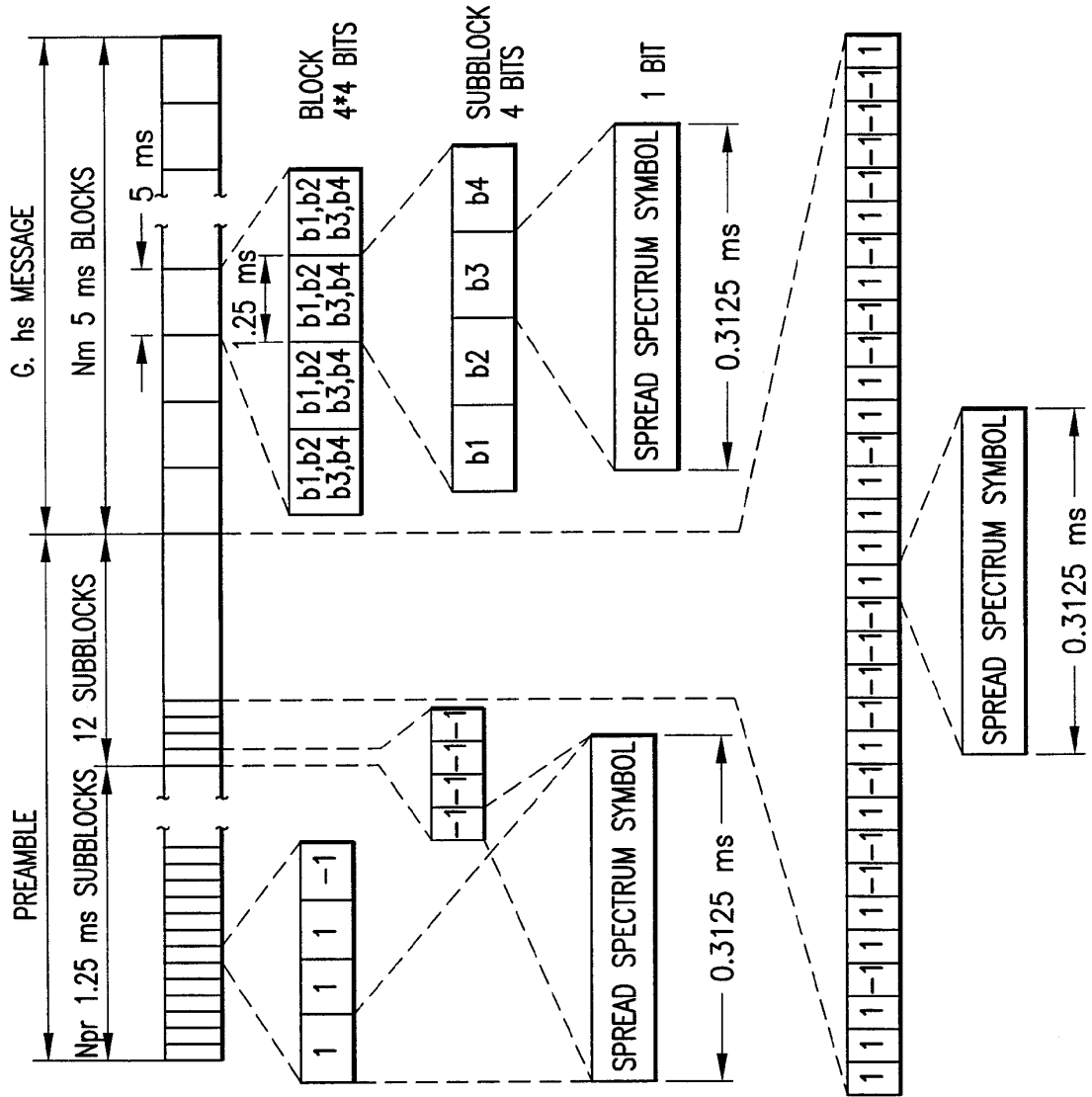

FIG.2

SUBSTITUTE SHEET (RULE 26)



3/3

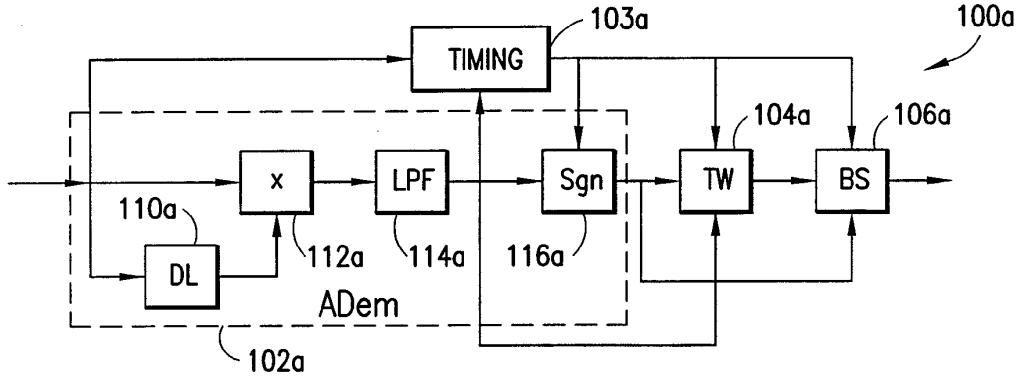

FIG.3a

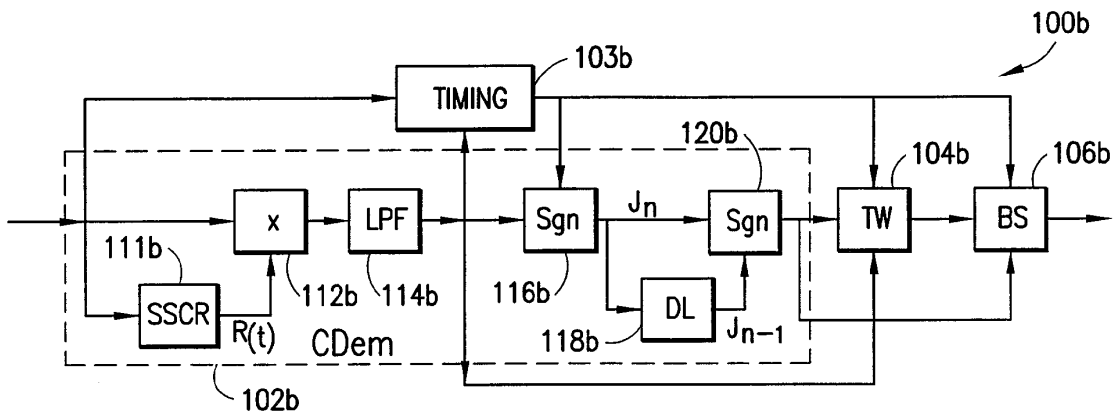

FIG.3b

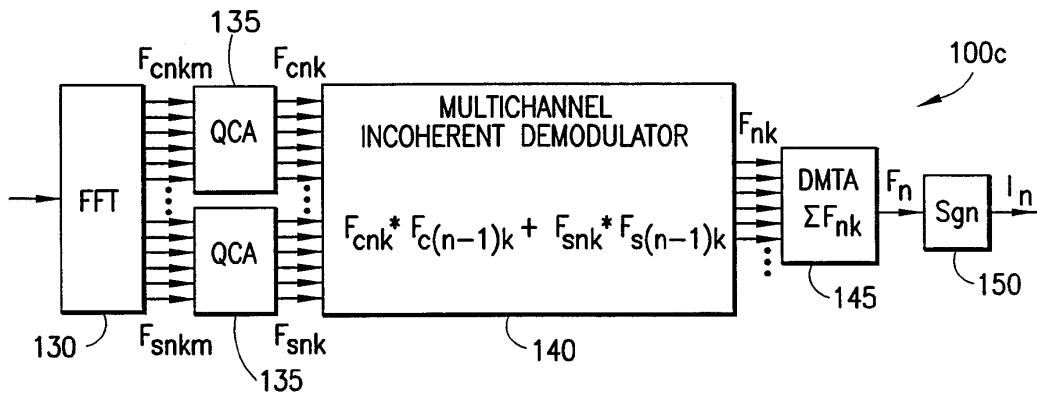

FIG.3c

SUBSTITUTE SHEET (RULE 26)

## INTERNATIONAL SEARCH REPORT

International application No.

PCT/US99/13817

<b>A. CLASSIFICATION OF SUBJECT MATTER</b>														
IPC(6) :H04B 1/38; H04L 5/16, 27/10, 27/18														
US CL :375/222, 223, 200, 208, 209, 210														
According to International Patent Classification (IPC) or to both national classification and IPC														
<b>B. FIELDS SEARCHED</b>														
Minimum documentation searched (classification system followed by classification symbols)														
U.S. : 375/222, 223, 200, 208, 209, 210														
Documentation searched other than minimum documentation to the extent that such documents are included in the fields searched														
Electronic data base consulted during the international search (name of data base and, where practicable, search terms used)														
APS														
<b>C. DOCUMENTS CONSIDERED TO BE RELEVANT</b>														
Category*	Citation of document, with indication, where appropriate, of the relevant passages	Relevant to claim No.												
Y	US 5,751,701 A (LANGBERG et al.) 12 May 1998, Figs. 3,4,7, and 10, cols. 3-7.	1-10, 12-21, 26-37												
Y,P	US 5,909,463 A (JOHNSON et al.) 01 June 1999, Figs. 1-4, col. 1, lines 20-60 and col. 16, lines 15-64.	1-10, 12-21, 26-37												
Y	US 5,644,573 A (BINGHAM et al.) 01 July 1997, col. 8, lines 50-60.	3-7, 9, 10, 31 and 32												
A,P	US 5,883,907 A (HOEKSTRA) 16 March 1999, Fig. 2 and col. 3, lines 27-35.	1-37												
<input type="checkbox"/> Further documents are listed in the continuation of Box C. <input type="checkbox"/> See patent family annex.														
<table border="0"> <tr> <td>* Special categories of cited documents:</td> <td>*T* later document published after the international filing date or priority date and not in conflict with the application but cited to understand the principle or theory underlying the invention</td> </tr> <tr> <td>*A* document defining the general state of the art which is not considered to be of particular relevance</td> <td>*X* document of particular relevance, the claimed invention cannot be considered novel or cannot be considered to involve an inventive step when the document is taken alone</td> </tr> <tr> <td>*E* earlier document published on or after the international filing date</td> <td>*Y* document of particular relevance; the claimed invention cannot be considered to involve an inventive step when the document is combined with one or more other such documents, such combination being obvious to a person skilled in the art</td> </tr> <tr> <td>*L* document which may throw doubts on priority claim(s) or which is cited to establish the publication date of another citation or other special reason (as specified)</td> <td>*G* document member of the same patent family</td> </tr> <tr> <td>*O* document referring to an oral disclosure, use, exhibition or other means</td> <td></td> </tr> <tr> <td>*P* document published prior to the international filing date but later than the priority date claimed</td> <td></td> </tr> </table>			* Special categories of cited documents:	*T* later document published after the international filing date or priority date and not in conflict with the application but cited to understand the principle or theory underlying the invention	*A* document defining the general state of the art which is not considered to be of particular relevance	*X* document of particular relevance, the claimed invention cannot be considered novel or cannot be considered to involve an inventive step when the document is taken alone	*E* earlier document published on or after the international filing date	*Y* document of particular relevance; the claimed invention cannot be considered to involve an inventive step when the document is combined with one or more other such documents, such combination being obvious to a person skilled in the art	*L* document which may throw doubts on priority claim(s) or which is cited to establish the publication date of another citation or other special reason (as specified)	*G* document member of the same patent family	*O* document referring to an oral disclosure, use, exhibition or other means		*P* document published prior to the international filing date but later than the priority date claimed	
* Special categories of cited documents:	*T* later document published after the international filing date or priority date and not in conflict with the application but cited to understand the principle or theory underlying the invention													
*A* document defining the general state of the art which is not considered to be of particular relevance	*X* document of particular relevance, the claimed invention cannot be considered novel or cannot be considered to involve an inventive step when the document is taken alone													
*E* earlier document published on or after the international filing date	*Y* document of particular relevance; the claimed invention cannot be considered to involve an inventive step when the document is combined with one or more other such documents, such combination being obvious to a person skilled in the art													
*L* document which may throw doubts on priority claim(s) or which is cited to establish the publication date of another citation or other special reason (as specified)	*G* document member of the same patent family													
*O* document referring to an oral disclosure, use, exhibition or other means														
*P* document published prior to the international filing date but later than the priority date claimed														
Date of the actual completion of the international search		Date of mailing of the international search report												
23 AUGUST 1999		21 OCT 1999												
Name and mailing address of the ISA/US Commissioner of Patents and Trademarks Box PCT Washington, D.C. 20231 Facsimile No. (703) 305-3230		Authorized officer MICHAEL W. MADDOX Telephone No. (703) 308-9557												

Form PCT/ISA/210 (second sheet)(July 1992)\*

## Electronic Acknowledgement Receipt

<b>EFS ID:</b>	7781850
<b>Application Number:</b>	12477742
<b>International Application Number:</b>	
<b>Confirmation Number:</b>	8072
<b>Title of Invention:</b>	SYSTEM AND METHOD FOR ESTABLISHING A DIAGNOSTIC TRANSMISSION MODE AND COMMUNICATING OVER THE SAME
<b>First Named Inventor/Applicant Name:</b>	David M. Krinsky
<b>Customer Number:</b>	62574
<b>Filer:</b>	Jason Vick/Debra Kesner
<b>Filer Authorized By:</b>	Jason Vick
<b>Attorney Docket Number:</b>	5550-2-CON-2-1
<b>Receipt Date:</b>	09-JUN-2010
<b>Filing Date:</b>	03-JUN-2009
<b>Time Stamp:</b>	17:56:32
<b>Application Type:</b>	Utility under 35 USC 111(a)

### Payment information:

Submitted with Payment	no
------------------------	----

### File Listing:

Document Number	Document Description	File Name	File Size(Bytes)/ Message Digest	Multi Part /.zip	Pages (if appl.)
1		IDS_02.pdf	332879 <small>25a1795435a3568b872845868a1471c767b1c906</small>	yes	4

Multipart Description/PDF files in .zip description					
Document Description			Start	End	
Transmittal Letter			1	3	
Information Disclosure Statement (IDS) Filed (SB/08)			4	4	
<b>Warnings:</b>					
<b>Information:</b>					
2	Foreign Reference	WO9967890A1.pdf	1092195	no	25
			201646c9374aee2813049e34385b2b5638721d80		
<b>Warnings:</b>					
<b>Information:</b>					
3	NPL Documents	5550-2-PEP5_OA_4-23-10.pdf	256735	no	9
			fd0bbf1e2c803ae4d8bd6bb178541cf1968032a84		
<b>Warnings:</b>					
<b>Information:</b>					
<b>Total Files Size (in bytes):</b>			1681809		
<p>This Acknowledgement Receipt evidences receipt on the noted date by the USPTO of the indicated documents, characterized by the applicant, and including page counts, where applicable. It serves as evidence of receipt similar to a Post Card, as described in MPEP 503.</p> <p><b><u>New Applications Under 35 U.S.C. 111</u></b>  If a new application is being filed and the application includes the necessary components for a filing date (see 37 CFR 1.53(b)-(d) and MPEP 506), a Filing Receipt (37 CFR 1.54) will be issued in due course and the date shown on this Acknowledgement Receipt will establish the filing date of the application.</p> <p><b><u>National Stage of an International Application under 35 U.S.C. 371</u></b>  If a timely submission to enter the national stage of an international application is compliant with the conditions of 35 U.S.C. 371 and other applicable requirements a Form PCT/DO/EO/903 indicating acceptance of the application as a national stage submission under 35 U.S.C. 371 will be issued in addition to the Filing Receipt, in due course.</p> <p><b><u>New International Application Filed with the USPTO as a Receiving Office</u></b>  If a new international application is being filed and the international application includes the necessary components for an international filing date (see PCT Article 11 and MPEP 1810), a Notification of the International Application Number and of the International Filing Date (Form PCT/RO/105) will be issued in due course, subject to prescriptions concerning national security, and the date shown on this Acknowledgement Receipt will establish the international filing date of the application.</p>					

IN THE UNITED STATES PATENT AND TRADEMARK OFFICE

In Re the Application of:	)	Group Art Unit: 2611
David M. Krinsky	)	Confirmation No.: 8072
Serial No.: 12/477,742	)	Examiner: Khanh C. Tran
Filed: June 3, 2009	)	
Atty. File No.: 5550-2-CON-2-1	)	<u>INFORMATION DISCLOSURE</u>
Entitled: "System and Method for Establishing a	)	<u>STATEMENT</u>
Diagnostic Transmission Mode and	)	Electronically Submitted
Communicating Over the Same "	)	

Commissioner for Patents  
P.O. Box 1450  
Alexandria, VA 22313-1450

Dear Sir:

The references cited on attached Form PTO-1449 are being called to the attention of the Examiner.

- Copies of the cited non-patent and/or foreign references are enclosed herewith.
- Copies of the cited U.S. patents and/or patent applications are enclosed herewith.
- Copies of the cited U.S. patents/patent application publications are not enclosed in accordance with 37 C.F.R. § 1.98(a).
- Copies of the cited references are not enclosed, in accordance with 37 C.F.R. § 1.98(d), because the references were cited by or submitted to the U.S. Patent and Trademark Office in prior application Serial No. \_\_\_\_\_ filed \_\_\_\_\_, which is relied upon for an earlier filing date under 35 U.S.C. § 120.
- To the best of applicants' belief, the pertinence of the foreign-language references are believed to be summarized in the attached English abstracts and in the figures, although applicants do not necessarily vouch for the accuracy of the translation.
- Examiner's attention is drawn to the following related applications:
  - Serial No. 12/779660 filed 05-13-2010 (Attorney's Ref. No. 5550-2-CON-2-1-1)
  - Serial No. 12/779708 filed 05-13-2010 (Attorney's Ref. No. 5550-2-CON-2-1-2)
- Other: \_\_\_\_\_

Submission of the above information is not intended as an admission that any item is citable under the statutes or rules to support a rejection, that any item disclosed represents analogous art, or that those skilled in the art would refer to or recognize the pertinence of any reference without the benefit of hindsight, nor should an inference be drawn as to the pertinence of the references based on the order in which they are presented. Submission of this statement should not be taken as an indication that a search has been conducted, or that no better art exists.

It is respectfully requested that the cited information be expressly considered during the prosecution of this application and the references made of record therein.

### FEES

<input type="checkbox"/>	<p><b>37 CFR 1.97(b):</b> No fee is believed due in connection with this submission, because the information disclosure statement submitted herewith is satisfied by one of the following conditions ("X" indicates satisfaction):</p> <p><input type="checkbox"/> Within three months of the filing date of a national application other than a continued prosecution application under 37 CFR 1.53(d), or</p> <p><input type="checkbox"/> Within three months of the date of entry into the national stage of an international application as set forth in 37 CFR 1.491 or</p> <p><input type="checkbox"/> Before the mailing date of a first Office Action on the merits, or</p> <p><input type="checkbox"/> Before the mailing of a first Office action after the filing of a request for continued examination under 37 CFR 1.114.</p> <p>Although no fee is believed due, if any fee is deemed due in connection with this submission, please charge such fee to Deposit Account 19-1970.</p>
<input checked="" type="checkbox"/>	<p><b>37 CFR 1.97(e):</b> The information disclosure statement transmitted herewith is being filed after all the above conditions (37 CFR 1.97(b)), but before the mailing date of one of the following conditions:</p> <p style="margin-left: 20px;">(1) a final action under 37 C.F.R. 1.113 or  (2) a notice of allowance under 37 C.F.R. 1.311, or  (3) an action that otherwise closes prosecution in the application.</p> <p>This Information Disclosure Statement is accompanied by:</p> <p><input checked="" type="checkbox"/> A Certification (below) as specified by 37 C.F.R. 1.97(e). Although no fee is believed due, if any fee is deemed due in connection with this submission, please charge such fee to Deposit Account 19-1970.</p> <p style="text-align: center;">OR</p> <p><input type="checkbox"/> Please charge Deposit Account 19-1970 in the amount of \$180.00 for the fee set forth in 37 C.F.R. 1.17(p) for submission of an information disclosure statement. Please credit any overpayment or charge any underpayment to Deposit Account 19-1970.</p>
<input type="checkbox"/>	<p><b>37 CFR 1.97(d):</b> This Information Disclosure Statement is being submitted after the period specified in 37 CFR 1.97(e).</p> <p><input type="checkbox"/> This information Disclosure Statement includes a Certification (below) as specified by 37 C.F.R. 1.97(e)</p> <p style="text-align: center;">AND</p> <p><input type="checkbox"/> Applicants hereby requests consideration of the reference(s) disclosed herein. Please charge Deposit Account 19-1970 in the amount of \$180.00 under 37 C.F.R. 1.17(p). Please credit any overpayment or charge any underpayment to Deposit Account 19-1970. Election to pay the fee should not be taken as an indication that applicant(s) cannot execute a certification.</p>

**Certification (37 C.F.R. 1.97(e))**  
(Applicable only if checked)

- The undersigned certifies that:
- Each item of information contained in this information disclosure statement was first cited in any communication from a foreign patent office in a counterpart foreign application not more than three months prior to the filing of this statement. 37 C.F.R. 1.97(e)(1).
  - A copy of the communication from the foreign patent office is enclosed.

OR

- No item of information contained in this information disclosure statement was cited in a communication from a foreign patent office in a counterpart foreign application, and, to the knowledge of the undersigned after making reasonable inquiry, no item of information contained in this Information Disclosure Statement was known to any individual designated in 37 C.F.R. 1.56(c) more than three months prior to the filing of this statement. 37 C.F.R. 1.97(e)(2).

Respectfully submitted,

SHERIDAN ROSS P.C.

By: \_\_\_\_\_

Jason H. Vick  
Registration No. 45,285  
1560 Broadway, Suite 1200  
Denver, Colorado 80202-5141  
(303) 863-9700

Date: 7 Jan 16

IN THE UNITED STATES PATENT AND TRADEMARK OFFICE

In Re the Application of: ) Group Art Unit: 2611  
)  
Krinsky et al. ) Examiner: TRAN, KHANH C  
)  
Serial No.: 12/477,742 ) Confirmation No.: 2611  
)  
Filed: 06-03-2009 ) REQUEST FOR CONSIDERATION OF  
) REFERENCE IN INFORMATION  
) DISCLOSURE STATEMENT  
) SUBMITTED MARCH 5, 2010  
Atty. File No.: 5550-2-CON-2-1 )  
For: SYSTEM AND METHOD FOR )  
ESTABLISHING A DIAGNOSTIC ) Electronically Submitted  
TRANSMISSION MODE AND )  
COMMUNICATING OVER THE )  
SAME )

Commissioner for Patents  
P.O. Box 1450  
Alexandria, VA 22313-1450

Dear Sir:

On March 5, 2010, Applicants submitted an Information Disclosure Statement in the above-identified patent application. The Information Disclosure Statement and the EFS Acknowledgment Receipt, is attached hereto as Exhibit A.

On June 8, 2010, the Examiner issued an Official Action for the above-identified case. The Official Action was accompanied by a List Of References Cited By Applicant And Considered By Examiner. This list included the aforementioned Information Disclosure Statement of March 5, 2010, but EP 0889615 (Ref. No. 22) was neither initialed, nor struck-through by the Examiner, with the "Examiner Initials" box next to Ref. No. 22 left blank. The List Of References Cited By Applicant And Considered By Examiner, is attached hereto as Exhibit B.

Due to the fact that the Information Disclosure Statement of March 5, 2010, was correctly submitted to the USPTO, Applicants hereby respectfully request that EP 0889615 (Ref. No. 22) listed in Information Disclosure Statement of March 5, 2010, be considered by the Examiner.



For the Examiner's convenience, a copy of EP 0889615 is provided herewith as Exhibit C.

Although no fees are believed due in connection with this communication, please charge any fees deemed necessary to Deposit Account No. 19-1970. If additional information is required please contact the undersigned.

Respectfully submitted,

SHERIDAN ROSS P.C.

By:   
Jason H. Vick  
Registration No. 45,285  
1560 Broadway, Suite 1200  
Denver, Colorado 80202-5141  
(303) 863-9700

Date: 9/5/16

# Exhibit A

IN THE UNITED STATES PATENT AND TRADEMARK OFFICE

In Re the Application of:	)	Group Art Unit: 2611
David M. Krinsky	)	Confirmation No.: 8072
Serial No.: 12/477,742	)	Examiner: Not yet assigned
Filed: June 3, 2009	)	
Atty. File No.: 5550-2-CON-2-1	)	<u>INFORMATION DISCLOSURE</u>
Entitled: "System and Method for Establishing a	)	<u>STATEMENT</u>
Diagnostic Transmission Mode and	)	Electronically Submitted
Communicating Over the Same "	)	

Commissioner for Patents  
P.O. Box 1450  
Alexandria, VA 22313-1450

Dear Sir:

The references cited on attached Form PTO-1449 are being called to the attention of the Examiner.

- Copies of the cited non-patent and/or foreign references are enclosed herewith.
- Copies of the cited U.S. patents and/or patent applications are enclosed herewith.
- Copies of the cited U.S. patents/patent application publications are not enclosed in accordance with 37 C.F.R. § 1.98(a).
- Copies of the cited references are not enclosed, in accordance with 37 C.F.R. § 1.98(d), because the references were cited by or submitted to the U.S. Patent and Trademark Office in prior application Serial No. \_\_\_\_\_ filed \_\_\_\_\_, which is relied upon for an earlier filing date under 35 U.S.C. § 120.
- To the best of applicants' belief, the pertinence of the foreign-language references are believed to be summarized in the attached English abstracts and in the figures, although applicants do not necessarily vouch for the accuracy of the translation.
- Examiner's attention is drawn to the following related applications:  
  - Serial No. 10/619691 filed 07-16-2003, now U.S. Patent No. 7570686 (Attorney's Ref. No. 5550-2-CON-2)
  - Serial No. 09/755173 filed 01-08-2001, now U.S. Patent No. 6658052 (Attorney's Ref. No. 5550-2)
- Other: \_\_\_\_\_

Submission of the above information is not intended as an admission that any item is citable under the statutes or rules to support a rejection, that any item disclosed represents analogous art, or that those skilled in the art would refer to or recognize the pertinence of any reference without the benefit of hindsight, nor should an inference be drawn as to the pertinence of the references based on the order in which they are presented. Submission of this statement should not be taken as an indication that a search has been conducted, or that no better art exists.

It is respectfully requested that the cited information be expressly considered during the prosecution of this application and the references made of record therein.

**FEEs**

<input checked="" type="checkbox"/>	<p><b>37 CFR 1.97(b):</b> No fee is believed due in connection with this submission, because the information disclosure statement submitted herewith is satisfied by one of the following conditions ("X" indicates satisfaction):</p> <p><input type="checkbox"/> Within three months of the filing date of a national application other than a continued prosecution application under 37 CFR 1.53(d), or</p> <p><input type="checkbox"/> Within three months of the date of entry into the national stage of an international application as set forth in 37 CFR 1.491 or</p> <p><input checked="" type="checkbox"/> Before the mailing date of a first Office Action on the merits, or</p> <p><input type="checkbox"/> Before the mailing of a first Office action after the filing of a request for continued examination under 37 CFR 1.114.</p> <p>Although no fee is believed due, if any fee is deemed due in connection with this submission, please charge such fee to Deposit Account 19-1970.</p>
<input type="checkbox"/>	<p><b>37 CFR 1.97(c):</b> The information disclosure statement transmitted herewith is being filed after all the above conditions (37 CFR 1.97(b)), but before the mailing date of one of the following conditions:</p> <p>(1) a final action under 37 C.F.R. 1.113 or</p> <p>(2) a notice of allowance under 37 C.F.R. 1.311, or</p> <p>(3) an action that otherwise closes prosecution in the application.</p> <p>This Information Disclosure Statement is accompanied by:</p> <p><input type="checkbox"/> A Certification (below) as specified by 37 C.F.R. 1.97(e). Although no fee is believed due, if any fee is deemed due in connection with this submission, please charge such fee to Deposit Account 19-1970.</p> <p style="text-align: center;">OR</p> <p><input type="checkbox"/> Please charge Deposit Account 19-1970 in the amount of \$180.00 for the fee set forth in 37 C.F.R. 1.17(p) for submission of an information disclosure statement. Please credit any overpayment or charge any underpayment to Deposit Account 19-1970.</p>
<input type="checkbox"/>	<p><b>37 CFR 1.97(d):</b> This Information Disclosure Statement is being submitted after the period specified in 37 CFR 1.97(c).</p> <p><input type="checkbox"/> This information Disclosure Statement includes a Certification (below) as specified by 37 C.F.R. 1.97(e)</p> <p style="text-align: center;">AND</p> <p><input type="checkbox"/> Applicants hereby requests consideration of the reference(s) disclosed herein. Please charge Deposit Account 19-1970 in the amount of \$180.00 under 37 C.F.R. 1.17(p). Please credit any overpayment or charge any underpayment to Deposit Account 19-1970. Election to pay the fee should not be taken as an indication that applicant(s) cannot execute a certification.</p>

**Certification (37 C.F.R. 1.97(e))**  
(Applicable only if checked)

- The undersigned certifies that:
- Each item of information contained in this information disclosure statement was first cited in any communication from a foreign patent office in a counterpart foreign application not more than three months prior to the filing of this statement. 37 C.F.R. 1.97(e)(1).
    - A copy of the communication from the foreign patent office is enclosed.
- OR
- No item of information contained in this information disclosure statement was cited in a communication from a foreign patent office in a counterpart foreign application, and, to the knowledge of the undersigned after making reasonable inquiry, no item of information contained in this Information Disclosure Statement was known to any individual designated in 37 C.F.R. 1.56(c) more than three months prior to the filing of this statement. 37 C.F.R. 1.97(e)(2).

Respectfully submitted,

SHERIDAN ROSS P.C.

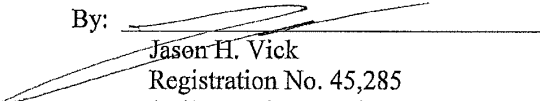
By:   
Jason H. Vick  
Registration No. 45,285  
1560 Broadway, Suite 1200  
Denver, Colorado 80202-5141  
(303) 863-9700

Date: 5 Mar '10

Substitute for form 1449A/PTO				<i>Complete if Known</i>	
<b>INFORMATION DISCLOSURE STATEMENT BY APPLICANT</b>				Application Number	12/477,742
				Filing Date	June 3, 2009
				First Named Inventor	David M. Krinsky
				Art Unit	2611
				Examiner Name	Not yet assigned
Sheet	1	of	4	Attorney Docket Number	5550-2-CON-2-1

U.S. PATENT DOCUMENTS					
Examiner Initials*	Cite No. <sup>1</sup>	Document Number Number-kind Code <sup>2 (if known)</sup>	Publication Date MM-DD-YYYY	Name of Patentee of Applicant of Cited Document	Pages, Columns, Lines, Where Relevant Passages or Relevant Figures Appear
	1	4385384	05/24/83	Rosbury et al.	
	2	4566100	01/21/86	Mizuno et al.	
	3	5128619	07/07/92	Bjork et al.	
	4	5361293	11/01/94	Czerwiec	
	5	5608643	03/04/97	Wichter et al.	
	6	5864602	01/26/99	Needle	
	7	5964891	10/12/99	Caswell et al.	
	8	6073179	06/06/00	Liu et al.	
	9	6075821	06/13/00	Kao et al.	
	10	6175934	01/16/01	Hershey et al.	
	11	6219378	04/17/01	Wu	
	12	6404774	06/11/02	Jenness	
	13	6411678	06/25/02	Tomlinson, Jr. et al.	
	14	6449307	09/10/02	Ishikawa et al.	
	15	6512789	01/28/03	Mirfakhraei	
	16	6631120	10/07/03	Milbrandt	
	17	6633545	10/14/03	Milbrandt	
	18	6636603	10/21/03	Milbrandt	
	19	6725176	04/20/04	Long et al.	
	20	6658052	12/02/03	Krinsky et al.	
	21	7570686	08/04/09	Krinsky et al.	

FOREIGN PATENT DOCUMENTS						
Examiner Initials*	Cite No. <sup>1</sup>	Foreign Patent Document Country Code <sup>3</sup> ; Number <sup>4</sup> ; Kind Code <sup>5</sup> (if known)	Publication Date MM-DD-YYYY	Name of Patentee or Applicant of Cited Document	Pages, Columns, Lines, Where Relevant Passages or Relevant Figures Appear	T <sup>6</sup>
	22	EP 0889615	01/07/99	INTEGRATED TELECOM EXPRESS		

Examiner Signature		Date Considered	
--------------------	--	-----------------	--

\*EXAMINER: Initial if reference is considered, whether or not citation is in conformance and not considered. Include copy of this form with next communication to applicant.

Substitute for form 1449A/PTO				<b>Complete if Known</b>	
<b>INFORMATION DISCLOSURE STATEMENT BY APPLICANT</b>				Application Number	12/477,742
				Filing Date	June 3, 2009
				First Named Inventor	David M. Krinsky
				Art Unit	2611
				Examiner Name	Not yet assigned
Sheet	2	of	4	Attorney Docket Number	5550-2-CON-2-1

	23	GB 2303032	02/05/97	SAMSUNG ELECTRONICS CO LTD		
	24	JP Hei6(1994)-003956	01/12/94	TELEBIT CORPORATION		(believed to correspond to WO 86/07223 disclosed herein)
	25	JP-A-Hei10(1998)-513622	12/22/98	ADC TELECOMMUNICATIONS INC		(Translated abstract)
	26	JP-A-Hei11(1999)-261665	09/24/99	MATSUSHITA GRAPHIC COMMUNIC		(Translated abstract)
	27	JP-A-Hei11(1999)-317723	11/16/99	MOTOROLA INC		(Translated abstract)
	28	JP-A-Hei11(1999)-508417	07/21/99	ERICSSON TELEFON AB L M		(Translated abstract)
	29	WO 00/64130	10/26/00	TERADYNE INC		
	30	WO 86/07223	12/04/86	TELEBIT CORPORATION		(believed to correspond to JP Hei6(1994)-003956 disclosed herein)
	31	WO 97/01900	01/16/97	ERICSSON AUSTRIA AG		
	32	WO 99/020027	04/22/99	Aware		
	33	WO 99/26375	05/27/99	TEKTRONIX INC		
	34	WO 99/63427	12/09/99	GTE LABORATORIES INC		

Examiner Signature		Date Considered	
--------------------	--	-----------------	--

\*EXAMINER: Initial if reference is considered, whether or not citation is in conformance and not considered. Include copy of this form with next communication to applicant.

Substitute for form 1449A/PTO				<b>Complete if Known</b>	
<b>INFORMATION DISCLOSURE STATEMENT BY APPLICANT</b>				Application Number	12/477,742
				Filing Date	June 3, 2009
				First Named Inventor	David M. Krinsky
				Art Unit	2611
				Examiner Name	Not yet assigned
Sheet	3	of	4	Attorney Docket Number	5550-2-CON-2-1

OTHER ART (Including Author, Title, Date, Pertinent Pages, etc.)		
Examiner Initials*	Cite No. <sup>1</sup>	
	35	Boets P. et al.: "Modeling Aspect of Transmission Line Networks" Proceedings Of The Instrumentation And Measurement Technology Conference, US, New York, IEEE, May 12, 1992, pp. 137-141, XP000343913 ISBN: 0-7803-0640-6
	36	Cioffi, John M., ADSL Maintenance with DMT, T1E1.4 ADSL Project, Amati Communications Corporation, December 1, 1992, pages 1-14
	37	Lewis L. et al. "Extending Trouble Ticket System to Fault Diagnostics" IEEE Network, IEEE Inc. New York, US, Nov. 1, 1993, pp. 44-51, XP 000575228
	38	International Search Report for PCT/US01/00418 dated Jul. 16, 2001; 4 pages (5550-2-PCT)
	39	Written Opinion for International (PCT) Patent Application No. PCT/US01/00418, completed March 9, 2002 (5550-2-PCT)
	40	International Preliminary Examination Report for International (PCT) Patent Application No. PCT/US01/00418, completed March 9, 2002 (5550-2-PCT)
	41	PCT International Search Report dated Oct. 9, 2002 for PCT/US01/41653 (5550-2-PCT-3)
	42	Examiner's First Report for Australian Patent Application No. 27669/01, mailed April 2, 2004 (Attorney's Ref. No. 5550-2-PAU)
	43	Notice of Acceptance for Australian Patent Application No. 27669/01, mailed August 6, 2004 (Attorney's Ref. No. 5550-2-PAU)
	44	Examiner's First Report for Australian Patent Application No. 2004203321, mailed November 16, 2006 (5550-2-PAU4)
	45	Examiner's First Report for Australian Patent Application No. 2008203520, mailed March 9, 2009 (5550-2-PAU4-DIV)
	46	Notice of Acceptance for Australian Patent Application No. 2008203520, mailed July 9, 2009 (5550-2-PAU4-DIV)
	47	Official Action for Canadian Patent Application No. 2,394,491, mailed November 24, 2009 (Attorney's Ref. No. 5550-2-PCA)
	48	Official Action for European Patent Application No. 01901808.4, mailed December 1, 2004 (Attorney's Ref. No. 5550-2-PEP)

Examiner Signature	Date Considered
--------------------	-----------------

\*EXAMINER: Initial if reference is considered, whether or not citation is in conformance and not considered. Include copy of this form with next communication to applicant.



Substitute for form 1449A/PTO				<b>Complete if Known</b>	
<b>INFORMATION DISCLOSURE STATEMENT BY APPLICANT</b>				Application Number	12/477,742
				Filing Date	June 3, 2009
				First Named Inventor	David M. Krinsky
				Art Unit	2611
				Examiner Name	Not yet assigned
Sheet	4	of	4	Attorney Docket Number	5550-2-CON-2-1

	49	Official Action for European Patent Application No. 01901808.4, mailed September 14, 2005 (Attorney's Ref. No. 5550-2-PEP)
	50	Communication about intention to grant a European patent for European Patent Application No. 01901808.4, mailed May 15, 2006 (Attorney's Ref. No. 5550-2-PEP)
	51	European Search Report for European Patent Application No. EP 06022008 completed January 8, 2007 (5550-2-PEP5)
	52	Notification of Reasons (Including translation) for Refusal for Japanese Patent Application No. 2001-552611, Dispatched Date: December 7, 2009 (Attorney's Ref. No. 5550-2-PJP)
	53	Decision to Grant Patent (including translation) For Korean Patent Application No. 10-2002-7008794, dated December 1, 2006 (Attorney's Ref. No. 5550-2-PKR)

Examiner Signature		Date Considered	
-----------------------	--	--------------------	--

\*EXAMINER: Initial if reference is considered, whether or not citation is in conformance and not considered. Include copy of this form with next communication to applicant.

## Electronic Acknowledgement Receipt

<b>EFS ID:</b>	7151383
<b>Application Number:</b>	12477742
<b>International Application Number:</b>	
<b>Confirmation Number:</b>	8072
<b>Title of Invention:</b>	SYSTEM AND METHOD FOR ESTABLISHING A DIAGNOSTIC TRANSMISSION MODE AND COMMUNICATING OVER THE SAME
<b>First Named Inventor/Applicant Name:</b>	David M. Krinsky
<b>Customer Number:</b>	62574
<b>Filer:</b>	Jason Vick/Debra Kesner
<b>Filer Authorized By:</b>	Jason Vick
<b>Attorney Docket Number:</b>	5550-2-CON-2-1
<b>Receipt Date:</b>	05-MAR-2010
<b>Filing Date:</b>	03-JUN-2009
<b>Time Stamp:</b>	15:11:48
<b>Application Type:</b>	Utility under 35 USC 111(a)

### Payment information:

Submitted with Payment	no
------------------------	----

### File Listing:

Document Number	Document Description	File Name	File Size(Bytes)/ Message Digest	Multi Part /.zip	Pages (if appl.)
1		IDS_01.pdf	674994 <small>G390f0ea54da1c4064e25b1c3079f9467765d18</small>	yes	7

Multipart Description/PDF files in .zip description					
	Document Description		Start		End
	Transmittal Letter		1		3
	Information Disclosure Statement (IDS) Filed (SB/08)		4		7
<b>Warnings:</b>					
<b>Information:</b>					
2	Foreign Reference	EP0889615A2.pdf	1848555	no	34
			931818aa76d18d918df6307adbfca64690b0e368		
<b>Warnings:</b>					
<b>Information:</b>					
3	Foreign Reference	GB2303032A.pdf	775828	no	24
			971ccd21e0ca715331e9fd91a66779e4b3d7a218		
<b>Warnings:</b>					
<b>Information:</b>					
4	Foreign Reference	JP10513622T.pdf	3431375	no	145
			888b9862465b4615c95ce831cee3890f52d0c1ea		
<b>Warnings:</b>					
<b>Information:</b>					
5	Foreign Reference	JP11261665A.pdf	935881	no	19
			ca6958f8bd979b468fa1f2332320bb306cd9de		
<b>Warnings:</b>					
<b>Information:</b>					
6	Foreign Reference	JP11317723A.pdf	471851	no	12
			4fa9bed1775109955d76b79bb73fae16bb62b62		
<b>Warnings:</b>					
<b>Information:</b>					
7	Foreign Reference	JP11508417T.pdf	1164326	no	47
			a3796603ff4abfa9d2b4b96f0ab15f9a5a117ff		
<b>Warnings:</b>					
<b>Information:</b>					
8	Foreign Reference	WO0064130A2.pdf	2380836	no	74
			8e0213e66164e2b763e631da8dd091e1e12e61f7		
<b>Warnings:</b>					
<b>Information:</b>					

9	Foreign Reference	WO8607223.pdf	2305273	no	53
			3376921f387058b8b4d2f445ed88e8b477016982		
<b>Warnings:</b>					
<b>Information:</b>					
10	Foreign Reference	WO9701900A1.pdf	1066593	no	20
			32287592098a865152b537c1ac279cdab6fd4099a		
<b>Warnings:</b>					
<b>Information:</b>					
11	Foreign Reference	WO99020027.pdf	3477643	no	71
			c650cb0032386da3c9b5646dcca940758b888d8		
<b>Warnings:</b>					
<b>Information:</b>					
12	Foreign Reference	WO9926375A2.pdf	1458669	no	31
			94f3868d54ccc0cb19877c8e7fb749b6b37ff		
<b>Warnings:</b>					
<b>Information:</b>					
13	Foreign Reference	WO9963427A1.pdf	986542	no	23
			d3d96d3f5ccc62ca2d9be876b4e36d5198fc3662		
<b>Warnings:</b>					
<b>Information:</b>					
14	NPL Documents	Boets_Modeling_Aspect_of_Transmission_Line_Networks.pdf	399671	no	6
			e3aabc3c165da136812ac990d82068488564dd13		
<b>Warnings:</b>					
<b>Information:</b>					
15	NPL Documents	Cioffi_ADSL_Maintenance_with_DMT_T1E1_4.pdf	764298	no	14
			a24c4bf9425f10d9789e1f0110fe4f5429b37c4		
<b>Warnings:</b>					
<b>Information:</b>					
16	NPL Documents	Lewis_Extending_Trouble_Ticket_System_to_Fault_Diagnostics.pdf	801049	no	8
			16aff63fa90c450f6db78fdb03c7a26a4900499		
<b>Warnings:</b>					
<b>Information:</b>					
17	NPL Documents	5550-2-PCT_Search_Report.pdf	156202	no	4
			cc80d36e54318f42cd19132342bee0ba2645a706		
<b>Warnings:</b>					
<b>Information:</b>					

18	NPL Documents	5550-2-PCT_Written_Opinion.pdf	241613 635f12c19d6917802a2146cce503dd896125fd7	no	2
<b>Warnings:</b>					
<b>Information:</b>					
19	NPL Documents	5550-2-PCT_IPER.pdf	85503 dfb57c85e9bdcc84d0df1b969e85eaece8ee0d83	no	2
<b>Warnings:</b>					
<b>Information:</b>					
20	NPL Documents	5550-2-PCT-3_Search_Report.pdf	146869 884805bc2f978db48c79adb5d8c30c17bdf36b5f	no	3
<b>Warnings:</b>					
<b>Information:</b>					
21	NPL Documents	5550-2-PAU_OA_4-2-04.pdf	56750 0d254394024b482c9ab6a3be9b3129efed146fc	no	1
<b>Warnings:</b>					
<b>Information:</b>					
22	NPL Documents	5550-2-PAU_OA_8-6-04.pdf	89133 bbe57d04fd2ca68ddc5f6cae83798870a581b996	no	2
<b>Warnings:</b>					
<b>Information:</b>					
23	NPL Documents	5550-2-PAU4_Examiners_First_Report_for_AU2004203321_11-16-06.pdf	131297 4f0b79b6b7c77cdcb00e51ab03715623ad52424	no	2
<b>Warnings:</b>					
<b>Information:</b>					
24	NPL Documents	5550-2-PAU4-DIV_OA_3-9-09.pdf	72889 2f41e077d06ead84bb4e4b1ab9c984fadeea72	no	2
<b>Warnings:</b>					
<b>Information:</b>					
25	NPL Documents	5550-2-PAU-4-DIV_NOA_7-9-09.pdf	64074 314f5bda4d26bc9ae7148ce5c7b16d51e700128	no	2
<b>Warnings:</b>					
<b>Information:</b>					
26	NPL Documents	5550-2-PEP_OA_12-1-04.pdf	143351 cd67e7101c9b24ab6ba46b14594788294b2b3fe	no	4
<b>Warnings:</b>					
<b>Information:</b>					

27	NPL Documents	5550-2-PEP_OA_9-14-05.pdf	52815 17e017eeccfe1b028e413830fafe689c1d1c10ca1	no	2
<b>Warnings:</b>					
<b>Information:</b>					
28	NPL Documents	5550-2-PEP_NOA_5-15-06.pdf	1363474 b9ad07b60b6f0b36ae37596a08b3e30ea52cd522	no	25
<b>Warnings:</b>					
<b>Information:</b>					
29	NPL Documents	5550-2-PEP5_European_Search_Report_for_EP_06022008_1-8-07.pdf	696810 9ac058a5710f5b6d193a484700c79ac3032cd1db	no	8
<b>Warnings:</b>					
<b>Information:</b>					
30	NPL Documents	5550-2-PJP_OA_12-7-09.pdf	325581 9bb7afb456a2a1034a70d0e1b7055792dbeebfd	no	8
<b>Warnings:</b>					
<b>Information:</b>					
31	NPL Documents	5550-2-PKR_NOA_12-1-06.pdf	112458 f51253e094455b82ddcdda340ca66f0571d8444	no	3
<b>Warnings:</b>					
<b>Information:</b>					
32	NPL Documents	JP_Hei6_1994-003956.pdf	1192136 798b375a7605b669bc529b15224f19aaa9624e95	no	15
<b>Warnings:</b>					
<b>Information:</b>					
33	NPL Documents	5550-2-PCA_OA_11-24-09.pdf	55806 5c821f1147f6958641910c83b7056e1f7845144	no	2
<b>Warnings:</b>					
<b>Information:</b>					
<b>Total Files Size (in bytes):</b>				27930145	

This Acknowledgement Receipt evidences receipt on the noted date by the USPTO of the indicated documents, characterized by the applicant, and including page counts, where applicable. It serves as evidence of receipt similar to a Post Card, as described in MPEP 503.

**New Applications Under 35 U.S.C. 111**

If a new application is being filed and the application includes the necessary components for a filing date (see 37 CFR 1.53(b)-(d) and MPEP 506), a Filing Receipt (37 CFR 1.54) will be issued in due course and the date shown on this Acknowledgement Receipt will establish the filing date of the application.

**National Stage of an International Application under 35 U.S.C. 371**

If a timely submission to enter the national stage of an international application is compliant with the conditions of 35 U.S.C. 371 and other applicable requirements a Form PCT/DO/EO/903 indicating acceptance of the application as a national stage submission under 35 U.S.C. 371 will be issued in addition to the Filing Receipt, in due course.

**New International Application Filed with the USPTO as a Receiving Office**

If a new international application is being filed and the international application includes the necessary components for an international filing date (see PCT Article 11 and MPEP 1810), a Notification of the International Application Number and of the International Filing Date (Form PCT/RO/105) will be issued in due course, subject to prescriptions concerning national security, and the date shown on this Acknowledgement Receipt will establish the international filing date of the application.

# Exhibit B



Substitute for form 1449A/PTO				<b>Complete if Known</b>	
<b>INFORMATION DISCLOSURE STATEMENT BY APPLICANT</b>				Application Number	12/477,742
				Filing Date	June 3, 2009
				First Named Inventor	David M. Krinsky
				Art Unit	2611
				Examiner Name	<del>Not yet assigned</del> KHANH C. TRAN
Sheet	1	of	4	Attorney Docket Number	5550-2-CON-2-1

U.S. PATENT DOCUMENTS					
Examiner Initials*	Cite No. <sup>1</sup>	Document Number Number-kind Code <sup>2 (if known)</sup>	Publication Date MM-DD-YYYY	Name of Patentee of Applicant of Cited Document	Pages, Columns, Lines, Where Relevant Passages or Relevant Figures Appear
/KCT/	1	4385384	05/24/83	Rosbury et al.	
	2	4566100	01/21/86	Mizuno et al.	
	3	5128619	07/07/92	Bjork et al.	
	4	5361293	11/01/94	Czerwicz	
	5	5608643	03/04/97	Wichter et al.	
	6	5864602	01/26/99	Needle	
	7	5964891	10/12/99	Caswell et al.	
	8	6073179	06/06/00	Liu et al.	
	9	6075821	06/13/00	Kao et al.	
	10	6175934	01/16/01	Hershey et al.	
	11	6219378	04/17/01	Wu	
	12	6404774	06/11/02	Jenness	
	13	6411678	06/25/02	Tomlinson, Jr. et al.	
	14	6449307	09/10/02	Ishikawa et al.	
	15	6512789	01/28/03	Mirfakhraei	
	16	6631120	10/07/03	Milbrandt	
	17	6633545	10/14/03	Milbrandt	
	18	6636603	10/21/03	Milbrandt	
	19	6725176	04/20/04	Long et al.	
	20	6658052	12/02/03	Krinsky et al.	
/KCT/	21	7570686	08/04/09	Krinsky et al.	

FOREIGN PATENT DOCUMENTS						
Examiner Initials*	Cite No. <sup>1</sup>	Foreign Patent Document Country Code <sup>3</sup> ; Number <sup>4</sup> ; Kind Code <sup>5</sup> (if known)	Publication Date MM-DD-YYYY	Name of Patentee or Applicant of Cited Document	Pages, Columns, Lines, Where Relevant Passages or Relevant Figures Appear	T <sup>6</sup>
	22	EP 0889615	01/07/99	INTEGRATED TELECOM EXPRESS		

Examiner Signature	/Khanh Tran/ (06/03/2010)	Date Considered	06/03/2010
--------------------	---------------------------	-----------------	------------

\*EXAMINER: Initial if reference is considered, whether or not citation is in conformance and not considered. Include copy of this form with next communication to applicant.

ALL REFERENCES CONSIDERED EXCEPT WHERE LINED THROUGH. /KCT

Substitute for form 1449A/PTO				<b>Complete if Known</b>	
<b>INFORMATION DISCLOSURE STATEMENT BY APPLICANT</b>				Application Number	12/477,742
				Filing Date	June 3, 2009
				First Named Inventor	David M. Krinsky
				Art Unit	2611
				Examiner Name	<del>Not yet assigned</del> KHANH C. TRAN
Sheet	2	of	4	Attorney Docket Number	5550-2-CON-2-1

/KCT/	23	GB 2303032	02/05/97	SAMSUNG ELECTRONICS CO LTD		
	24	JP Hei6(1994)-003956	01/12/94	TELEBIT CORPORATION		(believed to correspond to WO 86/07223 disclosed herein)
	25	JP-A-Hei10(1998)-513622	12/22/98	ADC TELECOMMUNICATIONS INC		(Translated abstract)
	26	JP-A-Hei11(1999)-261665	09/24/99	MATSUSHITA GRAPHIC COMMUNIC		(Translated abstract)
	27	JP-A-Hei11(1999)-317723	11/16/99	MOTOROLA INC		(Translated abstract)
	28	JP-A-Hei11(1999)-508417	07/21/99	ERICSSON TELEFON AB L M		(Translated abstract)
	29	WO 00/64130	10/26/00	TERADYNE INC		
	30	WO 86/07223	12/04/86	TELEBIT CORPORATION		(believed to correspond to JP Hei6(1994)-003956 disclosed herein)
	31	WO 97/01900	01/16/97	ERICSSON AUSTRIA AG		
	32	WO 99/020027	04/22/99	Aware		
	33	WO 99/26375	05/27/99	TEKTRONIX INC		
/KCT/	34	WO 99/63427	12/09/99	GTE LABORATORIES INC		

Examiner Signature	/Khanh Tran/ (06/03/2010)	Date Considered	06/03/2010
--------------------	---------------------------	-----------------	------------

\*EXAMINER: Initial if reference is considered, whether or not citation is in conformance and not considered. Include copy of this form with next communication to applicant.

ALL REFERENCES CONSIDERED EXCEPT WHERE LINED THROUGH. /KCT

Substitute for form 1449A/PTO				<b>Complete if Known</b>	
<b>INFORMATION DISCLOSURE STATEMENT BY APPLICANT</b>				Application Number	12/477,742
				Filing Date	June 3, 2009
				First Named Inventor	David M. Krinsky
				Art Unit	2611
				Examiner Name	<del>Not yet assigned</del> <b>KHANH C. TRAN</b>
Sheet	3	of	4	Attorney Docket Number	5550-2-CON-2-1

OTHER ART (Including Author, Title, Date, Pertinent Pages, etc.)		
Examiner Initials*	Cite No. <sup>1</sup>	
/KCT/	35	Boets P. et al.: "Modeling Aspect of Transmission Line Networks" Proceedings Of The Instrumentation And Measurement Technology Conference, US, New York, IEEE, May 12, 1992, pp. 137-141, XP000343913 ISBN: 0-7803-0640-6
	36	Cioffi, John M., ADSL Maintenance with DMT, T1E1.4 ADSL Project, Amati Communications Corporation, December 1, 1992, pages 1-14
	37	Lewis L. et al. "Extending Trouble Ticket System to Fault Diagnostics" IEEE Network, IEEE Inc. New York, US, Nov. 1, 1993, pp. 44-51, XP 000575228
	38	International Search Report for PCT/US01/00418 dated Jul. 16, 2001; 4 pages (5550-2-PCT)
	39	Written Opinion for International (PCT) Patent Application No. PCT/US01/00418, completed March 9, 2002 (5550-2-PCT)
	40	International Preliminary Examination Report for International (PCT) Patent Application No. PCT/US01/00418, completed March 9, 2002 (5550-2-PCT)
	41	PCT International Search Report dated Oct. 9, 2002 for PCT/US01/41653 (5550-2-PCT-3)
	42	Examiner's First Report for Australian Patent Application No. 27669/01, mailed April 2, 2004 (Attorney's Ref. No. 5550-2-PAU)
	43	Notice of Acceptance for Australian Patent Application No. 27669/01, mailed August 6, 2004 (Attorney's Ref. No. 5550-2-PAU)
	44	Examiner's First Report for Australian Patent Application No. 2004203321, mailed November 16, 2006 (5550-2-PAU4)
	45	Examiner's First Report for Australian Patent Application No. 2008203520, mailed March 9, 2009 (5550-2-PAU4-DIV)
	46	Notice of Acceptance for Australian Patent Application No. 2008203520, mailed July 9, 2009 (5550-2-PAU4-DIV)
	47	Official Action for Canadian Patent Application No. 2,394,491, mailed November 24, 2009 (Attorney's Ref. No. 5550-2-PCA)
	48	Official Action for European Patent Application No. 01901808.4, mailed December 1, 2004 (Attorney's Ref. No. 5550-2-PEP)

Examiner Signature	/Khanh Tran/ (06/03/2010)	Date Considered	06/03/2010
--------------------	---------------------------	-----------------	------------

\*EXAMINER: Initial if reference is considered, whether or not citation is in conformance and not considered. Include copy of this form with next communication to applicant.

ALL REFERENCES CONSIDERED EXCEPT WHERE LINED THROUGH. /KCT

Substitute for form 1449A/PTO				<i>Complete if Known</i>	
<b>INFORMATION DISCLOSURE STATEMENT BY APPLICANT</b>				Application Number	12/477,742
				Filing Date	June 3, 2009
				First Named Inventor	David M. Krinsky
				Art Unit	2611
				Examiner Name	<del>Not yet assigned</del> KHANH C. TRAN
Sheet	4	of	4	Attorney Docket Number	5550-2-CON-2-1

/KCT/	49	Official Action for European Patent Application No. 01901808.4, mailed September 14, 2005 (Attorney's Ref. No. 5550-2-PEP)
/KCT/	50	Communication about intention to grant a European patent for European Patent Application No. 01901808.4, mailed May 15, 2006 (Attorney's Ref. No. 5550-2-PEP)
/KCT/	51	European Search Report for European Patent Application No. EP 06022008 completed January 8, 2007 (5550-2-PEP5)
/KCT/	52	Notification of Reasons (Including translation) for Refusal for Japanese Patent Application No. 2001-552611, Dispatched Date: December 7, 2009 (Attorney's Ref. No. 5550-2-PJP)
/KCT/	53	Decision to Grant Patent (including translation) For Korean Patent Application No. 10-2002-7008794, dated December 1, 2006 (Attorney's Ref. No. 5550-2-PKR)

Examiner Signature	/Khanh Tran/ (06/03/2010)	Date Considered	06/03/2010
--------------------	---------------------------	-----------------	------------

\*EXAMINER: Initial if reference is considered, whether or not citation is in conformance and not considered. Include copy of this form with next communication to applicant.

ALL REFERENCES CONSIDERED EXCEPT WHERE LINED THROUGH. /KCT

# Exhibit C



(12) **EUROPEAN PATENT APPLICATION**

(43) Date of publication: 07.01.1999 Bulletin 1999/01 (51) Int. Cl.<sup>6</sup>: H04L 5/14, H04L 27/26  
 (21) Application number: 98112040.5  
 (22) Date of filing: 30.06.1998

(84) Designated Contracting States:  
**AT BE CH CY DE DK ES FI FR GB GR IE IT LI LU  
 MC NL PT SE**  
 Designated Extension States:  
**AL LT LV MK RO SI**  
 (30) Priority: 30.06.1997 US 884895  
 (71) Applicant:  
**Integrated Telecom Express  
 Santa Clara, California 95051 (US)**

(72) Inventors:  
 • Liu, Young Way  
**La Mirada, California 90638 (US)**  
 • Liu, Ming-Kang  
**Cupertino, California 95014 (US)**  
 • Chen, Steve  
**San Jose, California 95132 (US)**  
 (74) Representative:  
**Lins, Edgar, Dipl.-Phys. Dr.jur.  
 Gramm, Lins & Partner GbR,  
 Theodor-Heuss-Strasse 1  
 38122 Braunschweig (DE)**

(54) **Multicarrier transmission with variable data rate**

(57) A high speed communications system is provided which uses a selectable, desirable portion of the total available bandwidth of a transmission channel. In a preferred embodiment, the invention is an ADSL compatible modem which selects a sub-set of the available downstream DMT sub-channels based on an evaluation of such sub-channels by appropriate signal processing circuitry. An analog front end (AFE) contains sub-band filtering causes an upstream transceiver to use only this selected number of available sub-channels for down-

stream data transmission. This reduces hardware costs and complexity while still preserving compatibility with applicable ADSL standards and providing a high speed data link. The target data rate of the modem can be further enhanced to the point of achieving full protocol capability by increasing or upgrading the AFEs, and/or the signal processing circuitry in order to increase the number of processable transmitted downstream sub-channels.

**FIGURE 6**

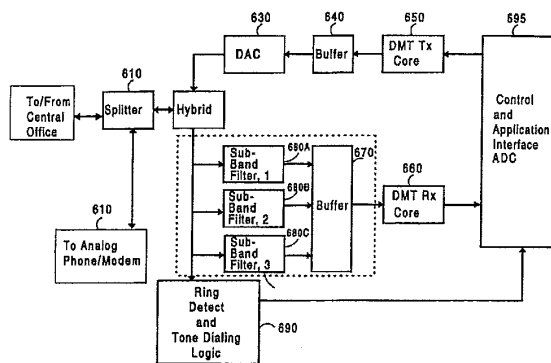

EP 0 889 615 A2

**Description**FIELD OF THE INVENTION

5 The invention relates generally to an improved high-speed communications system which establishes a data link using only a selectable portion of the total available bandwidth of a channel. The present invention has particular applicability to systems which use rate adaptable techniques such as the discrete multi-tone modulation (DMT) technique and CAP for transmitting data in Digital Subscriber Lines and similar environments. By limiting the data throughput of the link to some adjustable fraction of the total available data rate, the present invention significantly reduces hardware costs and allows a downstream user to configure a data link whose performance is directly controllable by the processing power available to such user. In this manner, the system is completely forward compatible and expandable in functionality, and permits a user to increase throughput to the point of achieving full potential of the available channel bandwidth.

15 BACKGROUND OF THE INVENTION

Remote access and retrieval of data and information are becoming more desirable and common in both consumer and business environments. As data and information transfer is becoming more and more voluminous and complex, using traditional data links such as voice-band modems is too slow in speed. For example, the use of the Internet to locate and access information is increasing daily, but the retrieval of typical graphics, video, audio, and other complex data forms is generally unsatisfyingly slow using conventional voice-band modems. In fact, the slow rate of existing dial-up analog modems frustrates users, and commerce and interaction using the Internet would have been even higher were it not for the unacceptable delays associated with present day access technology. The ability to provide such desired services as video on demand, television (including HDTV, video catalogs, remote CD-ROMs, high-speed LAN access, electronic library viewing, etc.), are similarly impeded by the lack of high speed connections.

Since the alternatives to copper line technology have proven unsatisfactory, solutions to the high speed access problem have been focused on improving the performance of voice band modems. Voice band modems operate at the subscriber premises end over a 3 kHz voice band lines and transmit signals through the core switching network, the phone company network treats them exactly like voice signals. These modems presently transmit up to 33.6 kbps over a 2-wire telephone line, even though the practical speed only twenty years ago was 1.2 kbps. The improvement in voice band modems over the past 20 years has resulted from significant advances in algorithms, digital signal processing, and semiconductor technology. Because such modems are limited to voice bandwidth (3.0 kHz), the rate is bound by the Shannon limit, around 30 kbps. A V.34 modem, for example, achieves 10 bits per Hertz of bandwidth, a figure that approaches the theoretical Shannon limits.

35 There is a considerable amount of bandwidth available in copper lines, however, that has gone unused by voice band modems, and this is why a proposal known as Asymmetric Digital Subscriber Line (ADSL) was suggested in the industry as a high-speed protocol/connection alternative. The practical limits on data rate in conventional telephone line lengths (of 24 gauge twisted pair) vary from 1.544 Mbps for an 18,000 foot connection, to 51.840 Mbps for a 1,000 foot connection. Since a large proportion of current telephone subscribers fall within the 18,000 foot coverage range, ADSL can make the current copper wire act like a much "bigger pipe" for sending computer bits and digital information (like movies and TV channels), while still carrying the voice traffic. For example, an ADSL modem can carry information 200 times faster than the typical voice band modem used today.

ADSL is "asymmetric" in that more data goes downstream (to the subscriber) than upstream (back from the subscriber). The reason for this is a combination of cost, demand, and performance. For example, twisted pair wiring coupling increases with the frequency of the signal. If symmetric signals in many pairs are used within a cable, the data rate and line length become significantly limited by the coupling noise. Since the preponderance of target applications for digital subscriber services is asymmetric, asymmetric bit rate is not perceived to be a serious limitation at this time. Therefore, the ADSL standard proposes up to 6 Mbps for downstream, and up to 640 kbps for upstream. For example, video on demand, home shopping, Internet access, remote LAN access, multimedia access, and specialized PC services all feature high data rate demands downstream, to the subscriber, but relatively low data rates demands upstream. The principal advantage is that all of the high speed data operations take place in a frequency band above the voice band, leaving Plain Old Telephone Service (POTS) service independent and undisturbed, even if an ADSL modem fails. ADSL further provides an economical solution for transmission of high bandwidth information over existing copper line infrastructures.

55 Specifically, the proposed standard for ADSL divides the available transmission bandwidth into two parts. At the lower 4 kHz band, ordinary (POTS) is provided. The bulk of the rest bandwidth in the range from 4 kHz to about 1 MHz is for data transmission in the downstream direction, which is defined to be from the exchange to the subscriber. The upstream control channel uses a 160 kHz band in between. The signals in each channel can be extracted with an

appropriate band -pass filter.

A DMT implementation of ADSL uses the entire available 1 MHz range of a copper phone line. It merely splits the signal into 255 separate channels, and each 4 kHz channel can be made to provide a bit rate up to the best present day voice band (33.6 kbs) modems. This results essentially in overall performance which is equivalent to around two hundred V.34 modems used in parallel on the same line. Because each channel can be configured to a different bit rate according to the channel characteristics, it can be seen that DMT is inherently "rate-adaptive" and extremely flexible for interfacing with different subscriber equipment and line conditions.

A number of problems arise, however, in attempting to implement a full scale ADSL transceiver cost-effectively.

First, to achieve this high bit rate transmission over existing telephone subscriber loops, advanced analog front end (AFE) devices, complicated digital signal processing techniques, and high speed complex digital designs are required. As a result, this pushes current technology limits and imposes both high cost and power consumption. For example, AFE devices in modem applications provide the interface between analog wave forms and digital samples for digital hardware/software processing. In high speed modem technologies such as ADSL, AFE devices need to operate at a very high sampling rate and high accuracy. For example, the DMT technology has a spectrum of 1 MHz and requires sampling above 50 MHz if a sigma-delta analog-to-digital (ADC) method is used. This thus requires the state-of-art ADC technology and imposes a high cost for end users.

Second, the time domain signal in ADSL/DMT transmissions is a summation of a large number of carriers modulated by quadrature amplitude modulation (QAM). This typically results in a large peak-to-peak deviation. As a result, even though a high speed AFE is made possible, a large dynamic range and high resolution AFE is required at the same time to minimize quantization errors.

Third, in addition to the high sampling rate and resolution requirement for ADSL AFEs, the other hardware and software in ADSL environment also needs to operate at a much higher speed than current conventional modem counterparts. For example, to implement the DMT technology in software, a custom and dedicated digital signal process (DSP) of a power of several hundred MIPS (millions instructions per second) is required to process many components such as error encoding and decoding, spectrum transforms, timing synchronization, etc. As with the AFE part of the system, this high speed requirement for the signal processing portion of ADSL also results in less flexible, high component costs.

Fourth, requiring a communications device (such as a modem) to fully support the total throughput of a standard such as ADSL may be inefficient in some cases, since many prospective users of high-speed data links may not need to use all the available bandwidth provided by such standards. It is generally more preferable therefore to permit users to throttle or scale the data throughput in a manner they can control, based on their particular application needs, hardware cost budget, etc. For example, a full-scale ADSL system may have the performance level of 200 times conventional V.34 modems, but it is apparent that even a performance improvement of 10 - 20 times than present day available analog modems would be sufficient for many consumer applications, such as Internet access and similar uses. Thus, unlike conventional analog modems, which are available in various speeds varying generally from 14.4 to 56 Kbps, there are no known ADSL modems which offer scalable performance levels to users.

Fifth, in addition to the implementation challenge, the T1E1.4 ADSL standard does not specify the system interface and user model. Although various high level interface to support T1 /E1, ATM, etc. have been described, system integration with high level protocols such as TCP/IP and interface with computer operating systems have not yet been defined. As a result, there is uncertainty how existing and future modem-based applications can work with the ADSL technology. For example, when users run an Internet application which sends and receives data to and from an Internet service provider (ISP), a mutually agreed protocol is required to set up a call and transfer data. Possible protocols available at various levels include ATM (asynchronous transfer mode), TCP/IP, ISDN, and current modem AT commands. Either one of these or a possibly new protocol needs to be defined to facilitate the adoption of ADSL technology.

#### SUMMARY OF THE INVENTION

An object of the present invention therefore is to provide a communications system which is fully compatible with high speed, rate adaptable protocols such as are used with ADSL, but which system is nevertheless implementable with simpler analog front end receiving/transmitting circuitry and is thus reduced in cost and complexity;

A further object of the present invention is to provide a communications system which is fully compatible with high speed, rate adaptable modulation protocols such as used with ADSL, but which system is nevertheless implementable with simpler digital signal processing circuitry and is thus reduced in cost and complexity;

Another objective of the present invention is to provide a method for transmitting data within a fractional, desirable portion of available bandwidth in a channel by modulating only a limited number of desirable sub-channel data carriers, so that a high speed data link can be achieved that is faster, and has reduced computation and hardware demands;

Yet a further objective of the present invention is to provide a communications system with smaller peak-to-peak deviation in the sub-channels signals, so as to reduce the dynamic range required for the front end ADC, and to mini-



mize quantization errors.

Another objective of the present invention is to provide a high speed communications system having a data throughput that is easily controllable and expandable, so that the performance range of such system can be configured to any fractional percentage of total bandwidth available in a transmission channel, up to and including full bandwidth use of the channel;

A related objective of the present invention is to provide a high speed communications system that is modular so that forward compatible and expandable functionality can be incorporated flexibly and with a minimum of effort on the part of a user of such system;

Yet a further objective is to provide a system that is compatible with high speed protocols used in ADSL, but which is also easily adaptable to support preexisting high level data protocols, including those presently used for controlling high speed voice band modems;

A further object of the present invention is to provide a high speed communications system that self-calibrates its own performance level, based on the processing power available to such system;

Another objective of the present invention is to provide a high speed communications system that permits a user to configure the performance parameters of such system using conventional personal computer hardware, software and operating systems;

A further object of the present invention is to provide an interface between a host operating system and a high speed communications system that provide forward compatible and expandable functionality;

An additional aim of the present invention is to provide an improved system for concurrent control of conventional voice data traffic on a POTS channel, and upstream/downstream communications on separate sub-channels;

These objects and others are accomplished by providing a communications system that permits a host processing device to receive selected data within a narrow bandwidth from an upstream transceiver which can and normally transmits a large bandwidth analog data transmission signal through a connected channel. A channel interface circuit AFE samples the received analog signal to generate a digital signal. Only a limited portion of the bandwidth may be sampled, thus reducing front end complexity. A digital signal processing circuit then extracts the selected data from this limited digital signal, which is significantly easier to process than a full bandwidth digital signal. Feedback information is provided back to the upstream transmitter which causes the upstream transmitter to transmit downstream data thereafter only using the limited bandwidth of the front end, and not the full bandwidth. This feedback information contains information about the channel that suggests to the upstream transmitter that the other bandwidth in the channel is unusable. In this manner, the upstream transceiver is trained to accommodate the lower rate downstream transceiver in a manner that nevertheless preserves protocol integrity.

In a preferred embodiment, the large bandwidth analog data transmission signal is comprised of a number of DMT modulated sub-channels, and an anti-aliasing filter on the front end of the the downstream transceiver ensures that only a limited number of such sub-channels are processed by a DMT signal processing core. The feedback information consists of non-zero SNR information for the selected sub-channels, and a sub-channel blackout "mask" to eliminate the potential use of other sub-channels. The feedback information is sent by way of a front end transmitting circuit which transmits an upstream data transmission using a second frequency range different from the downstream transmission.

One implementation of the aforementioned high speed system is in a personal computer, so that the signal processing can be accomplished using a processor within such computer, which in a preferred embodiment is an X86 compatible processor. Another implementation of the aforementioned high speed system uses a dedicated signal processor for demodulating the selected sub-channels. This cuts down on processing overhead requirements for a host processing system incorporating the system. In such implementations the portion of the downstream data transmission to be processed for data extraction can be configured by a user of such systems, or alternatively, it can be dynamically determined based on an evaluation by the digital signal processing circuit of performance characteristics of different portions of the frequency spectrum within the bandwidth potential of the upstream transceiver.

In another variation, the data rate of a system such as described above can be increased by processing data from an additional second limited frequency bandwidth portion of the total available downstream bandwidth. In a preferred embodiment, this can be done by including a number of anti-aliasing filters in a modular bank as part of the analog front end section, each of which passes a different frequency bandwidth portion. By making the analog front end modular, the data rate of the overall system can be scaled in a controllable and cost-effective fashion. At the same time, each analog front end portion can be operated at a slower sampling clock and smaller dynamic range. This results in a more relaxed speed requirement and smaller quantization noise at a given number of bits per sample.

The present disclosure also includes an interface to an operating system, to facilitate controlling the high speed communications system when it is incorporated in a personal computer system. This interface ensures that the operating system treats such communications system essentially the same as other prior art voice band modems, and in a preferred embodiment, is a device driver for the Windows NT operating shell. Finally, the present disclosure also describes an applications program which permits a user of a personal computer to control the performance characteristics of the high speed communications system by setting certain system parameters when such system is incorpo-

rated in a personal computer system. This program includes an auto calibration routine for setting such system parameters, or alternatively a user of such program can tailor the settings subject to confirmation of the efficacy of such settings based on an evaluation of the processing power available to such user.

5 Although the inventions are described below in a preferred embodiment implementing the ADSL standard, it will be apparent to those skilled in the art the present invention would be beneficially used in any high speed rate-adaptable applications.

It should be noted that while some prior art devices also have limited mechanisms for achieving a reduction of nominal or peak transmission speed in a channel, they only activate or implement such mechanisms as a fallback response to a failure in the channel, or because of a transmission rate reduction in the upstream transceiver. Unlike the present invention, such prior art modems, during an initialization process, attempt to establish the highest possible transmission rate achievable by the channel and the upstream transceiver. In other words, any rate reduction imposed by the downstream modem is typically considered an unintended and undesirable side effect of bad channel characteristics, and not a desirable and intentional design target as set forth in the present invention. In addition, the data rate reduction in such modems is accomplished primarily by varying the number of bits per baud (hertz) at a fixed frequency, and not by controlling the overall frequency spectrum of the downstream data transmission. Moreover, in such prior art systems, no effort is made to measure, identify or use an optimal portion of the usable bandwidth or set of transmission sub-channels. Instead, such prior art systems typically use whatever available bandwidth or sub-channels happen to be usable at that instant in time.

Similarly, while a fixed 300 baud rate downstream modem can work with an upstream 33kbs rate modem this arrangement is also unlike the present invention. This is because, again, the bandwidth reduction in such prior art device is so large that it is considered commercially unusable by today's standards. Furthermore, the smaller bandwidth modem is not compatible with, and does not support, the higher protocols of the higher bandwidth modem, which is also undesirable from an implementation standpoint. Stated another way, unlike the present invention, the lower end modem limitations of prior art system force the data link to be set up using a low level protocol that does not take advantage of the full capabilities of more advanced protocols.

25 Finally, there is no mechanism for users of either of the prior art systems noted above to expand the functionality of such modems in a controlled, flexible, and modular manner.

#### BRIEF DESCRIPTION OF THE DRAWINGS

30 Figure 1 is a pictorial depiction of the ADSL/DMT bandwidth allocation for upstream and downstream data in a channel based on frequency division multiplexing (FDM) configuration.  
 Figure 1B shows the relationship between a sub-band filter and an analog to digital converter that can be used in an analog front end (AFE) of the present invention;  
 35 Figure 1C is a pictorial depiction of a SNR curve for a typical subscriber loop channel using sub-channel modulation;  
 Figures 1D - 1G are mathematical modellings and charts that further explain the underlying physical premises of the present invention based on DMT ;  
 Figure 2 is a block diagram of a general implementation of a communications system employing the present invention, adapted for use in an ADSL environment ;  
 40 Figure 3A is a block diagram of a dedicated hardware implementation of a communications system employing the present invention, also adapted for use in an ADSL environment;  
 Figure 3B is a block diagram of a mixed hardware and software based implementation of a communications system employing the present invention, also adapted for use in an ADSL environment;  
 45 Figure 4 is a block diagram depicting the general structure of the data pump device driver used in the mixed implementation shown in Fig. 3;  
 Figure 5 is a flowchart depicting the general operation of the control and application interface used in the mixed implementation shown in Fig. 3 ;  
 50 Figure 6 is a block diagram of an implementation of a communications system employing the present invention, also adapted for use in an ADSL environment, in which it is depicted how a user can modularly expand throughput capability by adding additional AFE stages to process a greater percentage of the available bandwidth in the channel.

#### DETAILED DESCRIPTION OF THE INVENTION

55 While some of the concepts set forth immediately below are well-known, a brief explanation of ADSL technology is provided with reference to Figure 1 to facilitate an understanding of the present invention. As explained above, it is well-known in the art to use DMT to effectuate the ADSL standard. In contrast to most modulation schemes, such as AM/FM

transmissions that use one carrier, DMT uses multiple carriers to transmit data bits. Specifically, T1E1.4 ADSL standards specify an up to 255 channels for downstream transmission from the central office to subscribers and up to 31 channels for upstream transmission from subscribers to the central office. As shown in Figure 1, each carrier has a bandwidth of 4.3125 kHz. The total bandwidth is 1.1 MHz for a total of 255 channels. In the upstream direction, a "pilot" tone in the approximate range of 69 kHz, is used for maintaining timing synchronization. A similar pilot tone is transmitted in the downstream direction in the vicinity of 276 kHz.

Since upstream and downstream transmissions are over the same 2-pair twisted wire, they need to be separated by either echo cancellation (EC) or frequency division multiplexing (FDM). Echo cancellation allows simultaneous transmissions in both directions but requires a complex echo canceler implementation. On the other hand, FDM uses two different frequency bands for separate downstream and upstream transmissions. As shown in Figure 1, the upstream transmission uses subchannels from channel number 6 to 31, and the downstream transmission uses subchannels from channel number 41 to 255. While the remainder of the discussion below focuses on a system employing FDM, it will be appreciated by those skilled in the art that the present invention is adaptable and can be used beneficially with echo-cancellation approaches as well.

As with most communication environments, the transmission bit rates for both upstream and downstream communications in ADSL are not fixed but instead are determined by the quality of the channel. In the present invention, a number of well-known techniques can be used advantageously for setting up the initial data link. In general, these techniques work as follows: during initialization, the channel quality is measured and a certain data rate (typically a number of bits) is assigned for each DMT subchannel; thereafter, a "hand-shaking" process is used to dynamically and adaptively change the bit loadings (and energy levels). The latter is often necessary because (among other things) changes may occur in the overall channel characteristics, changes in the target bit rate may be needed, or new bit distributions in the sub-channels may be required because of degradations in one of the sub-channels.

The quality of the sub-channel response can be measured by the received signal to noise (SNR) ratio. According to the Shannon theorem, the upper limit of the number of bits per unit Hz that can be transmitted is  $\log_2(1+SNR)$ . Therefore, by measuring the received SNR at the receiver end, one can determine the number of bits allocated for each subchannel modulation. The total data throughput rate achieved by the system, therefore, is simply the sum of all the data rates of all the usable subchannels.

According to the T1 E1.4 ADSL standards, data bits are grouped and processed every 250  $\mu$ sec. The number of bits that can be processed over one such time frame is the summation of the bits allocated for each subchannel determined from the previous channel response measurement. For a given number of bits assigned to a certain subchannel, quadrature amplitude modulation (QAM) is used to convert bits to a complex value, which is then modulated by the subchannel carrier at the corresponding frequency.

The above is a merely a brief summary of the general operation of a typical DMT/ADSL communications system. The general circuits used in prior art ADSL systems, the specifics of the bit/energy loading process for the sub-channels, the bit fine tuning process, and the details of the modulation of the sub-channels, are well-known in the art, and will not be discussed at length herein except where such structures or procedures have been modified in accordance with the teachings herein.

The full downstream data throughput of a typical prior art ADSL standard transceiver approaches 6 Mbps, which is more than 200 times the speed of conventional analog modem technology. This requirement was imposed since a large part of the initial motivation to implement ADSL was to achieve high speed multimedia communications and video teleconferencing. Nevertheless, a large number of potential users do not want or need to have such wide bandwidth capability. For example, many potential users of ADSL (or similar high speed loops), including many who are intending to use such links primarily for Internet access, only need to achieve downstream transmission speeds that are in the hundreds of kilobits per second range. This data rate is in fact achievable using only a fraction of the available bandwidth of ADSL. By processing only a fraction of the available bandwidth of the ADSL standard, the present invention permits a limited but extremely useful ADSL modem to be implemented with significantly less expense and complexity than previously possible. At the same time, because the present invention has modular characteristics, the proposed implementation of the present invention affords users an easy path to forward and upward expansion of the overall functionality of their system.

The principle behind this aspect of the present invention is as follows: As shown in Fig. 1B, if the transmission in the channel is restricted to a smaller bandwidth by an anti-aliasing filter 80, according to the Nyquist sampling theorem, the sampling rate of AFE devices (such as ADC 81) that perform analog to digital conversion can be significantly reduced. Specifically, if the total downstream bandwidth is limited to some fractional total B Hz (in a preferred embodiment using DMT in an ADSL environment, B = 20 DMT channels or about 86 kHz) as shown below, we can limit the Nyquist sampling rate to around 180 kHz. This is achievable with ADCs having greatly simplified hardware and reduced performance requirements, in contrast to the full ADSL bandwidth approach, which processes 200 DMT channels or 900 kHz in the case of full ADSL implementation.

The total accumulated bit rate of an ADSL communications system using the present invention can be calculated

## EP 0 889 615 A2

as follows. Suppose a total number of  $k$  subchannels (out of a total of  $M$  possible) are to be supported and each channel is allocated  $b_k$  bits for transmission. The total accumulated bit rate ( $R$ ) is:

$$R = (\sum_{i=1,k} b_i) * 4 \text{ kHz (bits/sec)}$$

5 where 4 kHz is the framing rate defined by T1E1.4 ADSL standards. If  $k=20$  channels and the average number of bits per channel is 6, then total bit rate ( $R$ ) is approximately 480 kbits/sec. It can be seen that this fractional use of the ADSL bandwidth nevertheless provides about 9 times the performance of a conventional analog 56 kbits/sec digital modem. The benefits of this approach of the present invention are apparent. The overall performance and cost of a high speed  
10 communications system can be scaled and controlled in direct relationship to the particular needs of particular users. In general, the data rate supportable by (and the relative cost of) any particular implementation of the present invention is generally determined by two factors: (1) the capacity of the AFE; and (2) the capacity of the hardware performing the DMT.

15 The capacity of an AFE is generally measured by the maximum sampling speed it can achieve. As explained above, the sampling speed in turn determines the upper limit of the frequency band  $B$  (in kHz) that can be obtained. At the defined channel separation of 4.3125 kHz for ADSL, the total number of subchannels that can be supported is less than or equal to  $B/4.1325$ . A suitable ADC can be selected, therefore, based on the particular data rate and cost requirements of any particular user.

20 The other factor that limits the number of subchannels (and achievable data rate) is the processing power available for DMT modulation and demodulation routines. For example, a variety of performance levels (achievable data rates) are possible with well-known dedicated signal processing hardware, such as digital signal processors, as discussed in more detail below with reference to Figure 2. Alternatively, as shown in Figure 3, if such routines are implemented primarily by software and run by a host CPU, the required processing power (MIPS) generally increases directly as function of the number of subchannels that need to be processed. This is because, in general, most of the processings are  
25 done in serial, or a channel by channel basis. As discussed below in more detail, the present invention makes use of a "calibration" routine for estimating the total available processing power of a users computing system in order to set an upper limit of the total subchannels that can be supported.

Irrespective of the selection of the particular AFE or signal processing technique used, however, another useful (but not essential) aspect of the present invention is that the sub-channels with the largest signal to noise ratio (SNR)  
30 within the passband are selected for data transmission. In other words, in the preferred embodiment of the present invention, those  $k$  subchannels within the passband that support the largest number of bits are used for processing. As seen in Fig. 1C, for example, a standard two-wire subscriber line typically has a SNR curve that exhibits extensive attenuation with higher frequencies. It can be seen roughly in this figure that while there are more than 200 sub-channels provided for downstream transmission in ADSL, it is typically the case that 50% of the maximum data rate can be  
35 accomplished using only a much smaller percentage (than 50%) of the sub-channels. This fact is especially useful in considering some of the shared/ multi-channel bandwidth embodiments discussed further below.

The present invention, therefore, permits an implementation for a high speed data communications system that makes use of the best portion of the channel, while still being upwardly compatible and forward expandable. By these terms, it is meant that a system constructed in accordance with the teachings herein is completely compatible with a  
40 fully implemented version ADSL DMT modem. Moreover, it will be apparent to those skilled in the art that appropriate modifications specific to the channel and data link protocols and standards can be made so that the present invention can be advantageously employed in non-ADSL environments as well. Upward compatibility and forward expandability refer to the fact that systems constructed with the present teachings can have data rates that are easily upgraded while still preserving and maintaining compatibility with existing standards. For example, lower end users desiring less bandwidth can achieve a satisfactory performance with a minimum of cost, and can then upgrade the performance levels of  
45 their systems at later time by suitable (and preferably modular) upgrades of the AFE and signal processing hardware/software.

A system constructed in accordance with the present teachings is completely compatible with the full ADSL standard because of the following two aspects: According to the rate adaptation feature specified by the T1E1.4 ADSL standards, the bit rate for each sub-channel is determined initially (and preferably dynamically on an ongoing basis) by the  
50 sub-channel SNR analysis. Specifically, an ADSL downstream receiver can inform an upstream ADSL transmitter about the quality of the transmission; the receiver can also decide the bit rate for each sub-channel. Therefore, a downstream, partial-channel bandwidth receiver using the present invention can (based on the speed and passband of such receiver) supply an upstream, full-standard ADSL transmitter with information or control signals to effectuate a transmission only in selected sub-channels. In particular, in a preferred embodiment, the upstream ADSL transmitter is provided with SNR information for sub-channels outside the passband that is artificially contrived so as to suggest to the  
55 upstream transmitter that these sub-channels are not usable. In this manner, the downstream transmission is limited to a certain number of subchannels within the AFE and signal processing capabilities of the receiver. It can be seen, nev-

ertheless, that this scheme is completely transparent to the transmitter, thereby permitting a system built in accordance with the present teachings to be fully compatible with the ADSL standard. While not possible at this time within the ADSL standard, it is apparent that other high-speed data protocols may use a control signal, instead, to provide for express limiting and control of the identity of the sub-channels transmitting information.

5 As the technology improves for AFE devices and DMT implementation, the number of subchannels supported by a system using the present invention can increase. As a result, such systems can upgrade completely to a full T1E1.4 ADSL implementation using a single higher end modular replacement AFE devices, or alternatively, a number of lower end modular AFE devices.

#### 10 GENERAL EMBODIMENT OF PRESENT INVENTION

The basic structure of the present invention is depicted generally in Fig. 2. In general, the present invention can be embodied in different combinations of hardware and software. The primary difference between these embodiments is the specific implementation of the DMT core. These specific embodiments are described in more detail below with reference to Figs. 3A and 3B.

15 The structure and operation of ADSL transceivers is well-known in the art, and for that reason the present description primarily details those aspects of such transceivers which are necessary to an understanding of the inventions herein. As seen in Fig. 2, a channel 100 is made of a regular copper wire "loop", and each such loop may have differing electrical properties, transmission lengths (sizes), varying attenuation characteristics, and a number of impairments or interferences. Splitter 210, a conventional and well-known circuit, separates a DMT signal occupying more than 200 sub-channels from a lower end 4 kHz POTS analog signal. The latter can be used for simultaneous voice or conventional analog modem. Hybrid circuit 220 is also well-known in the art, and consists primarily of conventional transformers and isolation circuitry used in a wide variety of high-speed devices interfacing to standard telephone lines. A ring detect logic circuit 290 can also be implemented using accepted techniques, to alert a Control Interface 295 to the existence of a transmission signal originating from an upstream transceiver (not shown).

25 The full bandwidth signal is either low passed or bandpass limited to a frequency width  $B$  by suitable, well-known techniques as it passes through bandpass Filter and Analog/Digital Converter 280, so that only a fraction of the signal in the frequency domain is passed on to Buffer and DMT Receive Core 260. Again, the only important consideration for Subband Filter 280 is that it must constrain the bandwidth of the incoming signal to be  $\leq B$ , where the sampling rate of the Analog/Digital Converter is  $\geq 2B$ . This can be accomplished by using well-known filter designs. By suitable selection of circuitry for Filter and ADC 280, the overall system cost and performance can be scaled accordingly. In a preferred embodiment, the signal passed through Filter and ADC 280 occupies a spectrum between approximately 200 and 400 kHz. This selection is based primarily on an expected average performance of a typical two-wire line. It will be apparent to those skilled in the art that different bandpass widths and regions may be more suitable or optimal for other kinds of data links, or other kinds of multi-carrier modulation schemes.

35 Moreover, in some instances, while it is somewhat more expensive to implement, an adaptive or tunable filter may be substituted, such that the target frequencies of the passband are adjustable uniquely for each new data link. In such cases, the bandpass can be configured to coincide with the sub-channels having the highest achievable SNR, including the subchannels that must be supported for protocol or other system overhead reasons. Also, in some applications, the analog-to-digital conversion may be performed by a digital signal processor, or by the host computer and therefore, the sampling rate can be dynamically controlled and matched to the bandpass target frequency and frequency breadth. This feature, in turn, would assist dynamic scaling of the data throughput based on system computing power and overhead requirements.

40 Furthermore, in this preferred embodiment, using a multi-carrier approach implementation for ADSL, a pilot tone at 276 kHz must be allowed within the passband. It is apparent that other protocols may require similar pilot tones, and the design of comparable filters to achieve the functionality of Filter and ADC 280 is well within the ordinary skill of one in the art.

DMT Receiver Core 260 is generally responsible for monitoring and measuring the SNR of the sub-channels falling within the frequency range passed by FILTER and ADC 280, and for extracting the original data stream from the numerous sub-carriers. In a preferred embodiment, Control Interface 295 receives system configuration information from a host 298. This information may contain such parameters as target throughput rate  $R$ , target error rate, target center frequencies  $F$  for FILTER and ADC 280, target frequency width  $B$ , etc. By evaluating the SNR and bit capacities of the sub-channels computed by DMT Receiver Core 260, and taking into consideration the target data rate  $R$ , Control Interface 295 can select a number  $k$  of sub-channels up to and including the total available number  $M$  of sub-channels to carry the data stream from the upstream transmitter (not shown). The number of sub-channels that can be used for carrying data is directly related to the bandpass frequency  $B$  as described above. In a preferred embodiment,  $M = 200+$  (ADSL) and Control Interface 295 will usually configure  $k = 20$ .

For every sub-channel other than the selected  $k$  sub-channels, a "mask" or blackout control/feedback signal is gen-

erated and transmitted by DMT Tx Core 250, Buffer 260 and DAC 230 to the upstream transceiver. This ensures that any subsequent data transmissions by the upstream transceiver only use the selected  $k$  sub-channels. This feedback information is provided, therefore, irrespective of the transmitting capacity of the upstream transceiver, and even during times when the channel 100 is capable of supporting more than  $k$  sub-channels. In this manner, the present system is perceived by upstream transceiver to be compatible with protocols and performance characteristics of the upstream transceiver, because the upstream transmitter receives feedback information indicating merely that the two systems are connected through a channel with substantial signal attenuation characteristics for data signals outside the  $k$  sub-channels. Based on the inherent rate adaptiveness of ADSL and other similar protocols, the upstream transceiver will automatically train itself to use only the  $k$  sub-channels predetermined by the downstream transceiver. It should be noted that the DAC 230 and Buffer 240 in the front end transmitting circuit preferably transmit any upstream data transmissions using a second frequency bandwidth different from that of the downstream data transmission. However, this is not necessary in systems using echo-cancellation. Furthermore, in ADSL applications, the size of this bandwidth is considerably smaller, and uses only  $L$  sub-channels, where  $L < M$ . In other xDSL applications,  $L$  may be on the same order or larger than  $M$ .

Again, while the ADSL standard fixes the data error rate to be  $10^{-7}$ , it is conceivable that other applications of the present invention may tolerate a reduced error rate. For example, if maximum data throughput is required (i.e., the margin is less constrained) then the largest bit capacity sub-channels within  $B$  can be selected. Alternatively, if the system is error-performance driven and has more relaxed throughput requirements, than the 20 subchannels with the best margin are selected. A suitable combination of sub-channels can be selected by one skilled in the art based on the particular system requirements which may vary from application to application. Moreover, Controller Interface 295 may optimize the desired sub-channel mix dynamically depending on the type of data transmitted in channel 100. For example, streaming audio or video, or pictorial graphics, may require less integrity and error performance than other kinds of data used by  $n$  applications programs running on host 298. The specifics of the structure, operations and techniques used by Controller Interface 295 are not constrained by any requirements of the present invention, and can be implemented in various ways well-known to those skilled in the art.

The operation of the remainder of the circuitry shown in Fig. 2 is also relatively straightforward and not unlike a typical multi-carrier modulation system. Control Interface 295 ensures that DMT Transmit Core 250 performs bit and energy loading only for those sub-carriers necessary to effectuate a selected host throughput rate/error rate combination. As with the circuitry used for Filter ADC 280, the circuitry for performing the functions of DAC 230 can be implemented in programmable form to allow for greater flexibility.

Finally, while not presently supported in ADSL protocols, it is nevertheless possible that the filter in block 280 can be eliminated entirely in some applications when the sub-channel or downstream transmission frequencies can be configured through appropriate handshaking or similar procedures. In other words, if the upstream transmitter can be configured to transmit using only a portion of the bandwidth available in the channel, the advantages of the present invention can still be realized, because the ADC portion of block 280 can still be relatively less complex, since it will be processing at a much slower sampling rate than that required for a full spectrum implementation. Moreover, such an implementation would also yield the same commensurate savings in the DMT processing core, and reduced quantization errors.

Some special features of the present invention include the fact that:

(i) unlike hardware architectures implementing a full T1E1.4 ADSL standard, the present invention uses a filter in the front end. As mentioned earlier, the use of this filter is to allow low speed sampling by the ADC. If suitable handshaking between the upstream and downstream transceivers can be effectuated to generate a reduced downstream transmission, the filter can be eliminated.

(ii) standard ring detection logic is incorporated to support existing modem features;

(ii) DMT Rx core 260 is basically implemented the same way as specified by T1E1.4, but with some important differences, specifically:

[a] due to subband filtering and lower speed sampling, the frequency channels at the output of FFT (not shown) in the DMT Rx Core have a frequency shift

[b] Since not all 256 subchannels are necessarily supported by the DMT Rx Core 260, actual FFT implementation can be smaller, simpler and more cost-effective;

(iv) Control logic 295 permits the system to behave essentially like a conventional analog modem, and is used to support necessary setup tasks such as dialing and handshaking;

(v) The use of limited bandwidth from the downstream channel reduces the need for echo-cancellation circuitry, because there is less need for overlap between the upstream and downstream transmissions, and this further reduces system complexity and cost;

(vi) Because a smaller portion of the spectrum is processed by the present invention, the peak-to-peak deviation of the downstream signal is reduced, and this helps to minimize quantization errors.

#### DEDICATED HARDWARE BASED EMBODIMENT

5

Figure 3A illustrates an embodiment of the present invention that can be generally described as a dedicated hardware implementation. For the present discussion of Fig. 3A, it can be assumed that those circuits having like numbered references are the same and/or perform the same function as their counterpart in Fig. 2. For example, unless otherwise indicated, there is no material difference between Splitter 210 (Fig. 2) and Splitter 310 (Fig. 3A).

10

In this embodiment, the DMT sub-channel modulation core is implemented completely in dedicated processing hardware. For this application, DMT Receiver Core 260 typically includes a digital signal processor (DSP) (not shown) and including on-board program ROM (or other suitable memory) for storing executable microcode routines for performing bit, energy and SNR measurements of the carriers in the sub-channels. In such an embodiment, due to the power of the DSP, there is typically no need for processing assistance from a user's host processor 398. This embodiment

15

therefore may be advantageously employed where host processing power limitations are a consideration. A user of a system shown in Fig. 3A can expand the functionality (i.e., data throughput rate and modem features) of such system by upgrading the DMT Receiver Core 260, and where necessary, the AFE 280 as well. The system of Fig. 3A can be incorporated on a typical printed circuit board. By mounting or packaging the circuits used in such blocks in an accessible fashion, they can be replaced or supplemented much in the same way present users of personal computers can upgrade their motherboards to include additional DRAM. One practical alternative, for example, would be to have multiple available slots to accommodate new subband pass filters for passing a greater portion of the downstream transmission to be processed by the DMT core logic. Other practical and simple variations of this approach will be apparent to those skilled in the art.

#### 25 PARTIAL SOFTWARE BASED EMBODIMENT

In the above dedicated hardware embodiment, the overall speed (data throughput) can be maximized but with less flexibility for upgrades. This is because upgrades to such a system must take the form of hardware replacements, which can be more costly and difficult for the user to incorporate. On the other hand, as depicted in Fig. 3B, a number of important functions of a communications system can be completely implemented in software, in an analogous fashion to what is commonly described in the art as a "software" modem. In this case, the overall speed of the system depends on the user's processor power available at host 398, and only the AFE portion need be implemented in hardware.

30

The primary differences between the embodiments of Fig. 3A and 3B are the following: (1) implementation of DMT modulation; (2) implementation of the control and handshaking functions; and (3) implementation of the control interface. As seen in Figures 3B and 4, DMT Receive Core 460 and DMT Transmit Core 450 are implemented in a data pump device driver by the host system 398. In a preferred embodiment, host system 398 includes some form of multi-purpose microprocessor (such as an x86 type processor) running a suitable operating system (such as Windows by Microsoft), and is capable of executing suitable low level drivers for the DMT modulation (Fig. 4), as well as high level application software for implementing Control Interface 500 (Fig. 5). Host processor system 398 communicates over a standard bus interface 385 (i.e., a PCI bus) to Front End circuitry 396 for implementing a high speed modem. As with the circuitry in conventional analog modems, this circuitry of the present invention can be effectively incorporated on a PC motherboard (i.e., Bus Interface 385 and Front End Circuitry 396 can be merged so that they are essentially part of host system 398) or on a separate printed circuit board, or as a stand-alone unit physically separated from host 398. While this approach may not provide as much throughput performance, it has the advantage of being less expensive than the pure hardware approach of Fig. 2, and much easier to upgrade.

45

In the "software" modem implementation of Fig. 3 using a typical PC running Windows, the DMT Tx core 450, Rx Core 460 and Control/Handshaking logic are implemented as a Windows Data Pump Device Driver 400, which consist of DMT routines, associated control and handshaking codes, and an interface to kernel 480.

50

A more detailed characterization of a portion of host processing system 398 is depicted in Fig. 4, which illustrates a preferred embodiment of a device driver 400 as it would be constituted for a computer operating system shell 480. In the present embodiment, Microsoft Windows NT is considered, but it is understood that other comparable environments may be used, including UNIX, Windows 95, etc. As is well-known, operating system 480 is responsible for supervising and controlling the operation of processing system 398 and all of its associated peripheral devices. Operating system 480 also includes various interactive control and graphical application interfaces (Fig. 5) for permitting a user of processing system 398 to run various applications programs, and to set up, control, configure, monitor and utilize peripheral devices such as disk drives, printers, monitors, modems and the like.

55

To assist operating system 480 to interact and control such peripheral devices, it is also well-known to use device drivers, which are essentially low-level hardware routines executed by a host processor and operating system. A device

driver is a memory image file or executable file that contains all the code necessary to instruct a host processor to interface and drive a particular device within a computing system. Device driver 400 acts as an interface between an operating system 480 (in this case, Microsoft Windows NT) and hardware 396. In this case, for example, device driver 400 supports hardware 396 (see Fig. 3B), which is embodied in a typical printed circuit board (or external device). The teachings herein therefore provide for a new device driver that in combination with hardware 396 operates as a "software" modem. In this manner, operating system 480 classifies this combination as an ADSL modem, or in other words, another typical personal computer peripheral device, analogous to conventional voice-band modems.

Generally speaking, device driver 400 works as follows: a user of processing system 398 desiring to establish a data link to a remote site for transmitting/receiving data initiates such link through an application program (Fig. 5). Operating system 480 (Fig. 4) interprets and services this request by passing control of this task to device driver 400, which first generates appropriate instructions for a Device Initialization 440. In a preferred embodiment, Modem card 396 is initialized through Bus Interface 410 using conventional voice band modem control commands, so that the present invention is compatible with preexisting applications programs written for controlling modems using operating system 480. Similarly, therefore, control and data signals are interpreted and transmitted by operating system 480 to a Serial Port Interface 475 so that conventional modem dialing instructions and handshaking signals can be imparted to Modem Card 396 to establish a link through channel 100 to an upstream conventional ADSL transceiver (not shown). As explained above, after suitable handshaking protocols have been completed, the upstream fully compatible ADSL transceiver will begin transmitting data on all available M usable sub-channels. This downstream data is filtered by FILTER/ADC 380 and at this time, information for only N sub-channels ( $N \leq M$ ) is temporarily held in Buffer 370. At or before this same time, an interrupt is generated by bus interface 385 and passed through device driver bus interface 410 to alert Interrupt Service Router 415 to the existence of downstream data requiring processing. Thereafter, DMT Receive Core 460 begins processing the downstream data stream in response to control information from ISR 415. A demultiplexer 465 extracts and correlates the data in the various sub-channels before passing it on to Serial Port Interface 470, and back to Operating System 480. In this manner, Device Driver 400 coordinates with Modem card 396 to effectuate a software modem whose performance is directly correlated to the computing power of a processor contained within the host processing device.

As mentioned earlier, Device Driver 400 also contains control information for configuring the number and selection of sub-channels to be used in the particular data link established through channel 100 with the upstream transceiver during an initialization process. As also mentioned above, this control information may be self-determined by a user of host processing system 398, or alternatively, automatically sensed and monitored by such processing system, based on a computing performance rating for such system determined in a calibration routine. In either event, during the initialization process (and at all times subsequent) the upstream transceiver is induced to use such sub-channels only for the ensuing data transmission. This is accomplished by transmitting SNR information that is interpreted by the upstream transceiver as zero for all but  $K \leq N$  of the sub-channels of the driver selection. This data is passed under control of Operating System 480 through Serial Port 475, Framing control 455 and DMT Transmit Core 450 before being sent out to Modem Card 396 and channel 100.

It is understood, of course, that ADSL Modem 396 can also respond to a request from a remote modem for initiating the data link. The process for initializing the link, nevertheless, is essentially the same as that described above. Device driver 400 can also contain control logic for supporting typical dial-up modem operations and control codes from conventional modem application programs typically implemented in voice-band modems, such as setting up Originate/Answer modes, monitoring call progress, performing modem diagnostics, configuring receive/transmit buffer sizes, supporting facsimile transmissions, as well as performing enhanced error control, data compression and flow control between Modem Card 396 and Operating System 480. Device Driver 400 can also support other conventional "always-on" data link connections as desired, such as may be found in typical ethernet network connections, and other dedicated applications.

Given the teachings of the present invention, the general design of the above Data Pump Device Driver 400 is a routine task well within the abilities of one skilled in the art. The specifics of such implementation are not critical or essential to the present inventions, and will vary from application to application according to system designer requirements, so they are not included here. Again, while this embodiment of the present invention is set out in the context of a PC based host processor running Windows, it will be apparent to those skilled in the art that above description is merely an exemplary implementation. The referenced DMT routines, associated control and handshaking codes can be employed in numerous host processing/operating system environments, and in a variety of different coding organizations (high level or low level processing forms) well-known in the

In the preferred embodiment implemented using a standard PC running Windows, Control/Application interface 500 includes Win32 codes which provide standard modem utility functions and interface with Data Pump Device Driver 400. In Fig. 5, a flowchart of the operation of the Control/Application Interface 500 can be seen, which interface is discussed in more detail below.

Another particularly beneficial aspect of the embodiment of Fig. 3B is the provision of a self-determining "perform-



ance" or calibration rating that can be used to determine an optimal or maximum data throughput rate. In other words, the system of Fig. 3B can automatically and adaptively configure a host system 398 to a particular throughput rate based on an evaluation of the available computing power. In a preferred embodiment, the performance rating is determined based on a calibration routine executed by Data Pump Device Driver 400. This routine sets a timer, and counts  
 5 how many DMT frames can be processed within the given time; this gives a relative figure of merit for the particular host system in question. For each sub-channel to be added, one DMT frame needs to be processed within a small fraction of 250  $\mu$ s. Therefore, by incrementally increasing the sub-channel count, the overall effect on total system processing overhead can be determined. Control/Application Interface 500 provides the user with control to set a threshold of available host power for implementing the high speed link. Based on this threshold of available power (which can be nominally set to 20%) the number of subchannels that can be supported can be gleaned very quickly.  
 10

In view of current technology, when DMT processing is implemented in software, the host processing power is more likely to be the limiting factor than the frequency band of the subband filter 80 in Figure 1B. Nevertheless, because host processors (and especially microprocessors) are evolving in performance at a fairly rapid rate, the present invention affords users an opportunity to realize a high speed data link with performance that is controllable, and which improves  
 15 whenever there is an upgrade in the host processing system. Since many typical present day personal computer systems have easily accessible and replaceable host processors, users of the present invention can easily and flexibly expand and enhance the throughput and functionality of an ADSL modem.

An example of the flow chart for an ADSL modem application/control program 500 designed in accordance with the present teachings is shown in Fig. 5. With the teachings herein, a user of host processing system 398 can, for the first time, dynamically control a forward compatible and expandable modem, such as an ADSL modem, using modem-control applications software that is analogous to that only previously available for voice band modems. In a preferred embodiment, ADSL Modem Card 396 is automatically detected by Operating System 480 and set up by initialization routine 505 by Modem Device Driver 400. A separate detection routine 510 determines whether or not ADSL Modem Card 396 has been upgraded with an additional AFE (as described generally with reference to Figure 6 below), or alternatively whether a processor used in a host system has changed. The purpose of this step is primarily to determine  
 20 whether entries in a Device Parameters Table 560 need to be updated because of changes in computing power, front end capabilities or other parameters that may necessitate a modification of the data throughput characterization of the overall system when used in a communications mode.

A calibration routine 520 is then executed to determine the nominal setup parameters for the overall system in the manner described earlier. The results from this operation are stored in Device Parameter Table 560 where they then become accessible to various application programs that may make use of ADSL Modem Card 396 and Device Driver 400. The information stored in table 560 can include any or all of the following (a) measurements of the computing power available to the host processor; (b) measurements of the number of frames processable by the system within a particular time period; (c) estimations of the expected loading on the processing system based on demands of other applications programs and peripheral devices; (d) minimum and maximum data throughput estimations and/or targets;  
 35 (e) data identifying the type of host processor; (f) data identifying the number and type of AFEs in ADSL Modem card 396; (g) estimations and/or target system loading rates available for a datalink (i.e., maximum available processing time to be used by the system during data transmission); (h) data transmit and receive buffer sizes; (i) interrupt or similar priority data for the modem card; (j) estimations and/or target system sub-channel utilization; (k) estimations and/or target system sub-channel bit capacity information; etc. It will be apparent to skilled artisans that the above are just examples of the types of information that may be pertinent to the performance of a high speed communications system, and that other parameters may be considered depending on the environment, application, etc. in which the present invention is used.  
 40

After performing Auto Calibration routine 520, the results of the same are presented to the user for acceptance and verification at step 525. At this point, the user can accept the predetermined configuration data at step 526 (i.e., such as proposed maximum and minimum throughput rates, loading rates, etc.) and this would otherwise invoke an end of modem setup routine 590. Should the user not want to accept the recommended parameters, a Manual Configuration routine 530 is executed. At this juncture, various system performance data can be presented to the user for review, along with a list of modifiable system options 532. If for example, the user elects to increase the desired throughput rate,  
 50 a Verification routine 540 is then executed to determine whether such rate is reasonably sustainable within the other parameters of the system. If the new proposed configuration data is otherwise acceptable, then the Device Parameter Table 560 is updated, and the setup routine again ends. Otherwise, the user is alerted by a Notification/Suggestion routine 550, which points out the failure of the proposed configuration, and, if possible, makes suggestions to the user for modifying the system options 532 so that overall compliance can be achieved within the performance capability of the host processing system. The program then loops back to Acceptance routine 525, and thereafter the process is repeated until an acceptable configuration has been achieved, and any changes have been incorporated into Device Parameter Table 560.  
 55

While some of the operational steps above are described as implemented solely by Operating system 480 and

Device Driver 400, it is understood that such operations occur under direction of modem applications program 500, or in some cases, based on initialization routines executed by the host processing system. Moreover, to simplify the presentation of the present invention, only some of the features that may be implemented are described above, and many other well-known operational steps normally associated with setting up or monitoring modems are omitted.

5 As with the design of the above Data Pump Device Driver 400, the general design of the Control/Application Interface 500 required to accomplish the above functions is a routine task well within the abilities of one skilled in the art given the teachings herein. The specifics of such implementation are not critical or essential to the present inventions, and will vary from application to application according to system designer requirements, so they are not included here. Again, while this embodiment of the present invention is set out in the context of a PC based host processor running  
 10 Windows, it will be apparent to those skilled in the art that above description is merely an exemplary implementation. The referenced Control/Application Interface can be employed in numerous host processing/operating system environments, and in a variety of different coding organizations (high level or low level processing forms) well-known in the art.

15 *MULTIPLE AFE AND LOWER SAMPLING SPEED EMBODIMENT*

Figure 6 illustrates an example of the present invention wherein a user can achieve significantly increased data throughput using multiple low cost, low sampling speed AFEs, generally designated 680A, 680B, 680C, etc. As described above, these AFEs may be in separate, modular form and configured in a bank form so that they can be incorporated conveniently on a printed circuit board (or similar mounting) or integrated in a single IC chip. Each AFE  
 20 can be implemented in a fixed hardware configuration, or individually programmed/controlled to pass a certain portion of the downstream data transmission. Assuming suitable processing power is available for DMT modulation/demodulation (either through a dedicated or software implementation as described above in connection with Figs. 3A and 3B) a user of such system can achieve substantially expanded functionality by upgrades having performance characteristics and costs of their choice.

25 *UNDERLYING THEORY OF PRESENT INVENTION FOR ADSL/DMT APPLICATIONS*

A discussion of the underlying theory supporting the premise of the present invention now follows. In particular, this section shows the mathematical foundation For the use of multiple low speed AFE's to sample a full bandwidth  
 30 ADSL/DMT signal. It will be apparent to those skilled in the art, after reading this discussion, that the present inventions can be advantageously used in a number of rate adaptable communications environments, including CAP implementations of ADSL.

35 **DMT Transmitter**

To simplify the present discussion, only a subset of the DMT transmitter is considered, as shown in Figs 1D and 1E. The combined model that includes the channel response and the DMT receiver is shown below, where only one branch of band-pass filtering and sampling is shown for simplicity. To further simplify, the channel response and the SFIR are combined together.

40 In this subsection, we analyze the signal over one band pass filtering process. The result shows that the DMT signals within the band pass can be recovered with the same use of impulse response shortening technique. With use of multiple AFE's that cover different frequency bands, all DMT subchannels can be recovered. IFFT

In an ADSL environment as shown in Fig. 1D,  $N$  ( $N=512$ ) frequency domain variables are transformed into the time domain by IFFT block 60

$$y_n = \sum_{i=0}^{N-1} x_n e^{j2\pi i n / N}$$

50 **Cyclic Prefix**

$c$  time domain variables at the end are added to the prefix of the sequence as shown in Fig. 1D by block 70

$$\{z_n\} = \{z_{-c}, z_{-c+1}, \dots, z_{-1}, z_0, z_1, \dots, z_{N-1}\} = \{y_{N-c}, \dots, y_{N-1}, y_0, \dots, y_{N-1}\}$$

55 **AFE/DAC**

Discrete time domain sequence are converted by AFE 75 to the continuous time domain waveform as follows:

$$z(t) = \sum_{n=-\infty}^{\infty} z_n \rho_{TX}(t-nT_c),$$

5 where  $\rho_{TX}(t)$  is the transmitter pulse of the AFE/DAC used, and  $T_c$  is the transmitter DAC dock period and equal to

$$T_c = \frac{250 \mu\text{sec}}{N+C}$$

10 according to the DMT ADSL specifications.

### Channel

With reference now to Fig. 1E, if the channel impulse response is  $h_c(t)$ , we have

15

$$u(t) = \sum_{n=-\infty}^{\infty} z_n \rho_{RX}(t-nT_c)$$

20 where  $\rho_{RX}(t) = \rho_{TX}(t) \otimes h_c(t)$ .

### Bandpass Filtering

If the bandpass filter 80 has an impulse response of

25

$$h_{BPF}(t), v(t) = \sum_{n=-\infty}^{\infty} z_n \rho_{BPF}(t-nT_c)$$

30 where  $\rho_{BPF}(t) = \rho_{RX}(t) \otimes h_{BPF}(t)$ .

### AFE/ADC

Let the sampling clock be  $T_s = T_c \times L$ . This means a slower sampling by a factor of  $L$  for AFE 81. Thus,

35

$$w_k = \sum_{n=-\infty}^{\infty} z_n \rho_{BPF}(kT_s - nT_c) = \sum_{n=-\infty}^{\infty} z_n \rho_{BPF}([kL - n]T_c)$$

40 For causal pulse  $\rho_{BPF}(t)$ , we have

$$w_k = \sum_{n=-\infty}^{\infty} z_n \rho_{BPF}([kL - n]T_c) = \sum_{n=0}^{\infty} z_{kL-n} \rho_{BPF}(nT_c)$$

45

### Shortening FIR (SFIR)

After AFE discrete time sampling, a time domain equalizer (TEQ) called SFIR 82 is used to reduce the combined discrete time impulse response to a duration smaller than  $c$ . If the SFIR response is  $h_{SFIR}[n]$ , we have

50

55

$$\begin{aligned}
 r_k &= \sum_{i=0}^{N_1-1} w_{k-i} h_{SFIR}[i] \\
 &= \sum_{i=0}^{N_1-1} \left[ \sum_{n=-\infty}^{\infty} z_n p_{BPF}([kL-n-iL]T_c) \right] h_{SFIR}[i] \\
 &= \sum_{n=-\infty}^{\infty} z_n h_{tot}[kL-n] \\
 &= \sum_{n=0}^{\infty} z_{kL-n} h_{tot}[n]
 \end{aligned}$$

where

$$h_{tot}[kL-n] = \sum_{i=0}^{\infty} h_{SFIR}[i] p_{BPF}([kL-n-iL]T_c)$$

20 **Physical Meaning of  $h_{tot}[n]$**

If we perform discrete Fourier transform at block 84 for  $h_{tot}[n]$ , we obtain  $H_{tot}[\omega] = H_{SFIR}[L\omega] H_{BPF}[\omega]$  where  $H_{SFIR}[L\omega]$  and  $H_{BPF}[\omega]$  are the DFT's with period  $1/(LT_c)$  and  $1/T_c$ , respectively. Their spectra can be illustrated as shown in Fig. 1F for  $L=5$ .

25 **Dropping Cyclic Prefix**

By dropping the cyclic prefix of length  $c/L$ , at block 83 we consider only  $s_k = r_k, k=0, \dots, N_1-1$ , where  $N_1 = N/L$ .

30 **FFT**

Performing FFT at block 84 for  $s_k, k=0, \dots, (N/L)-1$ , one obtains:

$$\begin{aligned}
 q_n &= \sum_{l=0}^{N_1-1} s_l e^{-j2\pi nl / N_1} \\
 &= \sum_{k=0}^{N_1-1} r_k e^{-j2\pi nk / N_1} \\
 &= \sum_{k=0}^{N_1-1} \left( \sum_{i=0}^{\infty} z_{kL-i} h_{tot}[i] \right) e^{-j2\pi nk / N_1} \\
 &= \sum_{k=0}^{N_1-1} \sum_{i=0}^{\infty} z_{kL-i} h_{tot}[i] e^{-j2\pi n(kL-i) / N_1} e^{-j2\pi ni / N_1} \\
 &= \sum_{i=0}^{\infty} \sum_{k=0}^{N_1-1} z_{kL-i} e^{-j2\pi n(kL-i) / N_1} h_{tot}[i] e^{-j2\pi ni / N_1} \\
 &= \sum_{i=0}^c \sum_{k=0}^{N_1-1} z_{kL-i} e^{-j2\pi n(kL-i) / N_1} h_{tot}[i] e^{-j2\pi ni / N_1} \\
 &= \sum_{i=0}^c \sum_{k=0}^{N_1-1} y_{kL-i} e^{-j2\pi n(kL-i) / N_1} h_{tot}[i] e^{-j2\pi ni / N_1}
 \end{aligned}$$

where we assume  $h_{tot}[i]$  is only nonzero for  $i = 0, \dots, c$ . For a given  $i$ , let us define

$$l' = \lceil i/L \rceil;$$

5

We can then define  $i' = l'L - i$ , where  $i' = 0, \dots, L-1$ . Therefore,  $i = l'L - i'$   
 From the above definitions, we have

$$\begin{aligned} \sum_{k=0}^{N_1-1} y_{kL-i} e^{-j2\pi m(kL-i)/N_1} &= \sum_{k=0}^{l'-1} y_{kL-i} e^{-j2\pi m(kL-i)/N_1} + \sum_{k=l'}^{N_1-1} y_{kL-i} e^{-j2\pi m(kL-i)/N_1} \\ &= \sum_{k=0}^{l'-1} y_{(k-l')L+i'} e^{-j2\pi m((k-l')L+i')/N_1} + \sum_{k=l'}^{N_1-1} y_{(k-l')L+i'} e^{-j2\pi m((k-l')L+i')/N_1} \\ &= \sum_{k=0}^{l'-1} y_{(k-l'+N_1)L+i'} e^{-j2\pi m((k-l'+N_1)L+i')/N_1} + \sum_{k=0}^{N_1-l'-1} y_{kL+i'} e^{-j2\pi m(kL+i')/N_1} \\ &= \sum_{k=N_1-l'}^{N_1-1} y_{kL+i'} e^{-j2\pi m(kL+i')/N_1} + \sum_{k=0}^{N_1-l'-1} y_{kL+i'} e^{-j2\pi m(kL+i')/N_1} \\ &= \sum_{k=0}^{N_1-1} y_{kL+i'} e^{-j2\pi m(kL+i')/N_1} \end{aligned}$$

25

Therefore,

$$\begin{aligned} q_n &= \sum_{i=0}^c \sum_{k=0}^{N_1-1} y_{kL-i} e^{-j2\pi n(kL-i)/N_1} h_{tot}[i] e^{-j2\pi ni/N_1} \\ &= \sum_{i=0}^c \left[ \sum_{k=0}^{N_1-1} y_{kL+i'} e^{-j2\pi n(kL+i')/N_1} \right] h_{tot}[i] e^{-j2\pi ni/N_1} \\ &= \sum_{i=0}^c \left[ \sum_{k=0}^{N_1-1} \left( \sum_{l=0}^{N-1} x_l e^{j2\pi(kL+i')l/N} \right) e^{-j2\pi n(kL+i')/N_1} \right] h_{tot}[i] e^{-j2\pi ni/N_1} \\ &= \sum_{i=0}^c \left[ \sum_{k=0}^{N_1-1} \sum_{l=0}^{N-1} x_l e^{j2\pi(kL+i')(l-n)/N} \right] h_{tot}[i] e^{-j2\pi ni/N_1} \\ &= \sum_{i=0}^c \left[ \sum_{l=0}^{N-1} x_l \sum_{k=0}^{N_1-1} e^{j2\pi(kL+i')(l-n)/N} \right] h_{tot}[i] e^{-j2\pi ni/N_1} \end{aligned}$$

45

Since

$$\sum_{k=0}^{N_1-1} e^{j2\pi(kL+i')(l-n)/N} = 0 \text{ when } (l-n) \neq mN_1,$$

50

we have

$$q_n = N_1 \sum_{i=0}^c \left[ \sum_{m=0}^{L-1} x_{mN_1+i} e^{j2\pi i' m/L} \right] h_{tot}[i] e^{-j2\pi ni/N_1}$$

55

Knowing that  $h_{tot}[i]$  is zero for  $i < 0$  and  $i > c$ , we have

$$\begin{aligned}
 q_n &= N_1 \sum_{i=0}^c \left[ \sum_{m=0}^{L-1} x_{mN_1+n} e^{j2\pi i' m / L} \right] h_{tot}[i] e^{-j2\pi n i / N_1} \\
 &= N_1 \sum_{i=-\infty}^{\infty} \left[ \sum_{m=0}^{L-1} x_{mN_1+n} e^{j2\pi i' m / L} \right] h_{tot}[i] e^{-j2\pi n i / N_1} \\
 &= N_1 \sum_{l=-\infty}^{\infty} \sum_{i'=0}^{L-1} \left[ \sum_{m=0}^{L-1} x_{mN_1+n} e^{j2\pi i' m / L} \right] h_{tot}[lL - i'] e^{-j2\pi n (lL - i') / N_1} \\
 &= N_1 \sum_{m=0}^{L-1} x_{mN_1+n} \sum_{i'=0}^{L-1} e^{j2\pi i' m / L} \sum_{l=-\infty}^{\infty} h_{tot}[lL - i'] e^{-j2\pi n (lL - i') / N_1}
 \end{aligned}$$

Since

$$\begin{aligned}
 \sum_{l=-\infty}^{\infty} h_{tot}[lL - i'] e^{-j2\pi n (lL - i') / N_1} &= \sum_{l=-\infty}^{\infty} h_{tot}[lL - i'] e^{-j\omega (lL - i') T_c} \Big|_{\omega=2\pi n / NT_c} \\
 &= F \left\{ h_{tot}(t) \sum_l \delta(t - [lL - i'] T_c) \right\} \Big|_{\omega=2\pi n / NT_c} \\
 &= \frac{1}{2\pi} \mathcal{F}_{tot}(\omega) \otimes \left[ \frac{2\pi}{LT_c} \sum_l \delta(\omega - \frac{2\pi l}{LT_c}) e^{j2\pi l i' / L} \right] \Big|_{\omega=2\pi n / NT_c} \\
 &= \frac{1}{LT_c} \sum_l \mathcal{F}_{tot}(\frac{2\pi n}{NT_c} - \frac{2\pi l}{LT_c}) e^{j2\pi l i' / L}
 \end{aligned}$$

we have

$$\begin{aligned}
 q_n &= N_1 \sum_{m=0}^{L-1} x_{mN_1+n} \sum_{i'=0}^{L-1} e^{j2\pi i' m / L} \sum_{l=-\infty}^{\infty} h_{tot}[lL - i'] e^{-j2\pi n (lL - i') / N_1} \\
 &= N_1 \sum_{m=0}^{L-1} x_{mN_1+n} \sum_{i'=0}^{L-1} e^{j2\pi i' m / L} \frac{1}{LT_c} \sum_l \mathbf{H}_{tot}(\frac{2\pi n}{NT_c} - \frac{2\pi l}{LT_c}) e^{j2\pi l i' / L} \\
 &= \frac{N_1}{LT_c} \sum_{m=0}^{L-1} x_{mN_1+n} \sum_l \mathbf{H}_{tot}(\frac{2\pi n}{NT_c} - \frac{2\pi l}{LT_c}) \sum_{i'=0}^{L-1} e^{j2\pi (l+m) i' / L} \\
 &= \frac{N_1}{T_c} \sum_{m=0}^{L-1} x_{mN_1+n} \mathbf{H}_{tot}(\frac{2\pi n}{NT_c} + \frac{2\pi m}{LT_c}) \\
 &= \frac{N_1}{T_c} \sum_{m=0}^{L-1} x_{mN_1+n} \mathbf{H}_{tot}(\frac{2\pi}{NT_c} [mN_1 + n]), \quad n = 0, \dots, N_1 - 1 \\
 &= N_1 \sum_{m=0}^{L-1} x_{mN_1+n} \mathbf{H}_{tot}[mN_1 + n], \quad n = 0, \dots, N_1 - 1
 \end{aligned}$$

where

$$\mathbf{H}_{tot}[n] = \frac{1}{T_c} \mathbf{H}_{tot}(\frac{2\pi}{NT_c} n), \text{ for } 0 \leq n < N$$

**Relationship between  $q_n$  and  $x_n$**

As shown in Fig. 1G if  $\bar{H}_{tot}[n]$  is a bandpass filter and nonzero only in the intervals  $[k(N/2L), (k+1)(N/2L)]$  and  $[(2L-k-1)(N/2L), (2L-k)(N/2L)]$ , where  $0 \leq k < L$ , the possible values of  $m$  that

5

$$\mathbf{H}_{tot}[m(N/L) + n]$$

10 is nonzero for  $0 \leq n < (N/L)$  are as follows.

**Even  $k$**

If  $k$  is even, we can have  $m=k/2$  and  $0 \leq n < (N/2L)$  so that

15

$$\mathbf{H}_{tot}[m(N/L) + n]$$

20

is nonzero over the interval  $[k(N/2L), (k+1)(N/2L)]$ , and  $m=(L-1)-k/2$  and  $(N/2L) \leq n < (N/L)$  so that

$$\mathbf{H}_{tot}[m(N/L) + n]$$

25

is nonzero over the interval  $[(2L-k-1)(N/2L), (2L-k)(N/2L)]$ .

**Odd  $k$**

30 If  $k$  is odd, we can have  $m=(k-1)/2$  and  $(N/2L) \leq n < (N/L)$  so that

$$\mathbf{H}_{tot}[m(N/L) + n]$$

35

is nonzero over the interval  $[k(N/2L), (k+1)(N/2L)]$ , and  $m=L-(k-1)/2$  and  $0 \leq n < (N/2L)$  so that

$$\mathbf{H}_{tot}[m(N/L) + n]$$

40

is nonzero over the interval  $[(2L-k-1)(N/2L), (2L-k)(N/2L)]$ .

The above discussion is illustrated in Fig. 1G for  $L = 3$ .

In another variation that can be used in the present invention, similar advantages to those obtained by limiting bandwidth in the received signal in the downstream transceiver can be obtained by also optionally limiting the upstream data rate of the transceiver as well. In other words, the ADSL standard provides for 31 channels in the upstream direction, but many applications do not require this amount of bandwidth. The constraints, requirements and costs associated with the DMT modulation signal processing, and DAC 330 also can be significantly reduced by transmitting only a sub-set of the available 31 sub-channels. The determination of the appropriate sub-channels would be accomplished in essentially the same manner as set forth above, except that the information on upstream sub-channel SNR usually must be determined by the upstream transceiver, and then fed back to the downstream transceiver. To save time and overhead complexity, and given the fact that there is less variation in bit capacity in sub-channels in this frequency band, one approach also would be to simply select a fixed sub-set of such sub-channels-without regard to their actual performance characteristics. In a software modem environment, Control/Application software 500 would provide a user with selectable control to effectuate a restricted upstream transmission on limited sub-channels. Again, with respect to the ADSL standard, the only requirement in this respect is that the upstream pilot tone must also be transmitted to establish a valid data link. An optional limited "upstream" transmission can be effectuated in a variety of ways by the circuitry already described above in connection with Figs. 2 and 3. The exact details of such implementation will be appar-

ent to those of skill in the art given the present teachings.

Although the present invention has been described in terms of a preferred ADSL embodiment, it will be apparent to those skilled in the art that many alterations and modifications may be made to such embodiments without departing from the teachings of the present invention. For example, it is apparent that the present invention would be beneficial used in any xDSL or high speed multi-carrier application environment. Other types of VLSI and ULSI components beyond those illustrated in the foregoing detailed description can be used suitably with the present invention. Accordingly, it is intended that the all such alterations and modifications be included within the scope and spirit of the invention as defined by the following claims.

#### 10 Claims

1. A high speed communications system capable of supporting a downstream data transmission from a upstream transceiver using a analog signal consisting of M data carrying signals contained within a bandwidth F, said system comprising:
  - 15 a channel interface circuit for coupling to and receiving said analog signal; and
  - a front end receiving circuit for processing the analog signal and converting it to a digital signal;
  - a processing circuit for extracting N data carrying signals ( $N < M$ ) from the digital signal using a first frequency portion  $f_1$  of the digital signal ( $f_1 < F$ ).
2. The system of claim 1, wherein the N data carrying signals are selected by the processing circuit based so as to minimize the amount of processing required to extract the selected data from the digital signal.
3. The system of claim 2, wherein the N data carrying signals can be selected during a initialization process setting up a data link to the upstream transceiver.
4. The system of claim 3, wherein M data carrying signals can be sent by the upstream transmitter during a initialization process, and thereafter, only N data carrying signals are sent.
5. The system of claim 1, wherein the front end circuit includes: (i) a sub-band filter for passing the first frequency bandwidth portion  $f_1$  of said bandwidth F; (ii) and an analog to digital converter.
6. The system of claim 1, wherein the selected data further includes data obtained from an additional second frequency bandwidth portion  $f_2$  of said bandwidth F, so that an additional number of data carrying signals P from the M data carrying signals ( $N+P < M$ ) can be processed.
7. The system of claim 6, further including one or more sub-band filters for passing the first frequency bandwidth portion  $f_1$  and second frequency bandwidth portion  $f_2$  of said bandwidth F and an analog to digital converter.
8. The system of claim 7, wherein a target data rate of the system can be increased by processing an additional number of data carrying signals P from the M data carrying signals, where  $N+P < M$ .
9. The system of claim 1, wherein the selected data to be extracted from the bandpassed data can be controlled by a user of such system.
10. The system of claim 9, wherein a user of such system can increase a target data rate of the system by modularly augmenting the front end circuit to include additional bandwidth and analog to digital conversion capacity such that an additional number of data carrying signals P from the M data carrying signals ( $N+P < M$ ) can be processed.
11. The system of claim 1, further including a front end transmitting circuit for transmitting control information to cause said upstream transceiver to transmit downstream data only using the N data carrying signals.
12. The system of claim 11, wherein the control information transmitted to the upstream transceiver includes feedback information indicating that only N of the M data carrying signals are desirable for downstream data transmission, even during times when said channel is capable of supporting more than N data carrying signals.
13. The system of claim 12, wherein the control information transmitted to the upstream transceiver further includes feedback information indicating that: (i) the system can support any data protocols used by said upstream trans-



ceiver; and (ii) that they are connected through a channel with substantial signal attenuation characteristics for data signals other than the N data carrying signals.

- 5
14. The system of claim 1, further including a front end transmitting circuit for transmitting an upstream data signal using a second frequency bandwidth F2 different from F<sub>1</sub> and L data carrying signals, and where  $L < M$ .
15. A high speed communications system for processing an analog data signal from a channel capable of supporting M modulated sub-channels, said system comprising:
- 10
- a channel interface circuit for coupling to and receiving said analog data signal from the channel;
  - a analog front end circuit for processing the analog data signal and converting it to a digital signal;
  - 15 a processing circuit for extracting data from the digital signal, the digital signal including data taken from a number N of said sub-channels, where N is intentionally selected to have a value less than M and where N is negotiated with an upstream transceiver during an initialization procedure.
16. The system of claim 15, where the N sub-channels are initially loaded with bit capacities that are left essentially unchanged unless said channel characteristics vary.
- 20
17. The system of claim 15, wherein the selection of the N sub-channels can be done during the initialization procedure.
18. The system of claim 15, wherein the value of N is based on signal processing capability of the processing circuit.
- 25
19. The system of claim 15, wherein a target data rate of the system can be increased by processing a additional number of sub-channels P from the M sub-channels, and where  $N+P < M$ .
20. The system of claim 15 further including a front end transmitting circuit for transmitting control information to cause said upstream diver to transmit downstream data only using the N sub-channels.
- 30
21. The system of claim 15, wherein the upstream transceiver uses discrete multi-tone (DMT) modulation for generating the M modulated sub-channels, and the channel supports asymmetric digital subscriber loop (ADSL) transmission standards.
- 35
22. A high speed communications system for processing an analog data signal from a channel capable of supporting M modulated sub-channels, said system comprising:
- 40
- a channel interface circuit for coupling to and receiving said analog data signal from the channel;
  - an analog front end circuit for processing the analog data signal and converting it to a digital signal;
  - 45 a bus interface circuit for transmitting the digital signal to a host processing device, and for receiving a transmission control signal from the host processing device to cause said upstream transmitter to transmit using only from a number N of said sub-channels, where N is intentionally selected to have a value less than M, and where N is negotiated with a upstream transceiver during an initialization procedure.
23. The system of claim 22, wherein the value of N is based on signal processing capability of the host processing device.
- 50
24. The system of claim 22, wherein a data rate of the system can be increased by processing an additional number of sub-channels P from the M sub-channels, and where  $N+P < M$ .
25. The system of claim 22, wherein the upstream transceiver uses discrete multi-tone (DMT) modulation for generating the M modulated sub-channels, and the channel supports asymmetric digital subscriber loop (ADSL) transmission standards.
- 55
26. A method of processing a xDSL signal from a digital subscriber loop, said method including the steps of:

negotiating a reduced data rate  $R'$  for said signal between a downstream and an upstream transceiver; and

thereafter transmitting said xDSL signal from the upstream transceiver to the downstream transceiver utilizing a number of sub-channels  $N$  to effectuate the reduced data rate  $R'$ , where  $N$  is intentionally selected to be less than a maximum number of sub-channels  $M$  supported by said digital subscriber loop; wherein the number of sub-channels  $N$  is based on signal processing capability available to the downstream transceiver.

27. The method of claim 26, wherein the data rate of the system can be increased by processing an additional number of sub-channels  $P$  from the  $M$  sub-channels, and where  $N+P < M$ .

28. The method of claim 26, wherein the upstream transceiver uses discrete multi-tone (DMT) modulation for generating the  $M$  sub-channels.

29. The method of claim 26, wherein the reduced data rate  $R'$  can be specified by a user operating the downstream transceiver.

30. A high speed communications data receiver for communicating through a channel at a data rate  $X$  with an upstream transmitter capable of transmitting a data stream at a rate  $Y$  ( $X < Y$ ), the receiver comprising:

a channel interface circuit for coupling to and receiving said data stream; and  
 an analog front end circuit for data sampling the analog signal and converting it to a digital signal; and  
 a processing circuit for extracting selected data from the digital signal, and for generating a transmission control signal for causing said upstream transmitter to transmit at a data rate substantially equal to said data rate  $X$  during a data stream transmission; and  
 wherein data sampling requirements of the analog front end circuit and extracting of the processing circuit are reduced because data sampling and extracting is only performed for a fractional portion of the data stream.

31. The system of claim 30, wherein the analog front end circuit further includes one or more sub-band filters for filtering the analog data signal to generate the fractional portion of the data stream that requires data sampling and extracting.

32. The system of claim 30, further including a front end transmitting circuit for transmitting the transmission control signal from the processing circuit to cause said upstream transceiver to transmit downstream data only at said data rate  $X$ .

33. The system of claim 32, wherein the control information transmitted to the upstream transceiver includes feedback information indicating that the maximum downstream data transmission data rate is  $X$ , even during times when said channel is capable of supporting more than said data rate  $X$ .

34. The system of claim 30, further including a front end transmitting circuit for transmitting an upstream data transmission using a data rate  $Z$ , where  $Z < Y$ .

35. The system of claim 30, wherein the ratio of  $X$  to  $Y$  is approximately .5 or less, and this ratio can be increased through modular additions to the analog front end circuit.

36. A high speed communications data receiver for communicating through a channel with an upstream transmitter that is capable of transmitting a data signal with a particular frame rate  $T$  and data rate  $Y$ , the receiver comprising:

a channel interface circuit for coupling to and receiving said data signal; and  
 an analog front end circuit for sampling the data signal and converting it to a digital signal; and  
 a processing circuit that: (i) is configurable for processing the digital signal at a data rate  $\leq X$  and using said frame rate  $T$ , where  $X$  is determined for such processing circuit prior to initialization of a data transmission and  $X < Y/2$ ; (ii) generates a transmission control signal for causing said upstream transmitter to transmit at a data rate no greater than  $X$  during a data transmission;  
 wherein signal processing requirements for the processing circuit are reduced because processing is only performed at a fractional rate of the available data rate of said transmission protocol.

37. The system of claim 36, wherein the control information transmitted to the upstream transceiver includes feedback information indicating that the maximum downstream data transmission data rate is X, even during times when said channel is capable of supporting more than said data rate X.
- 5 38. The system of claim 36, wherein the feedback information including the data rate X can be controlled by a user of such system.
39. The system of claim 36, wherein the ratio of X to Y is approximately .2 or less.
- 10 40. A high speed communications system for transmitting digital information in a channel capable of supporting a transmission bandwidth F, said system comprising:
- an upstream data transceiver capable of modulating the digital information to generate an analog data signal data transmission using said transmission bandwidth F; and
- 15 a downstream data transceiver channel interface circuit for coupling to and receiving said analog data signal from the upstream data transceiver through said channel, the downstream data transceiver including:
- (i) a front end receiving circuit for processing the analog data signal and converting it to a digital signal; and
- 20 (ii) a processing circuit for demodulating the digital signal, the digital signal including data from a first frequency bandwidth portion f1 of said bandwidth and for generating feedback information indicating to the upstream transceiver that the bandwidth other than f1 is unsuitable for data transmission; and
- (iii) a front end transmitting circuit for transmitting the feedback information using a second frequency bandwidth portion f2 to cause said upstream transceiver to transmit downstream data only using the first frequency portion f1.
- 25 41. The system of claim 40, wherein the ratio of f1 to F is approximately .5 or less, and this ratio can be increased through modular additions to the front end receiving circuit.
42. The system of claim 40, wherein the feedback information contains intentionally altered channel characteristic information.
- 30 43. The system of claim 41, wherein the feedback information, including the size and location of first frequency portion f1, can be controlled by a user of such system.
- 35 44. A high speed communications data receiver for communicating through a channel at a controllable data rate X with an upstream transmitter capable of transmitting a data signal at a frame rate T, and a data rate Y, where  $X/Y < 1/2$ , the receiver comprising:
- a channel interface circuit for coupling to and receiving said analog data signal; and
- 40 an analog front end circuit for data sampling the analog signal and converting it to a digital signal; and a processing circuit for determining said rate X based on processing capabilities available for extracting data from the digital signal, and for generating a transmission control signal for causing said upstream transmitter to transmit using said frame rate T, and a data rate substantially equal to said data rate X during a data transmission.
- 45 45. The receiver of claim 44, wherein said rate X is determined during a calibration routine.
46. The receiver of claim 45, wherein said calibration routine is executed by a host data processor to determine the capabilities of such processor.
- 50 47. The receiver of claim 44, wherein said rate X is configurable by a user of such receiver based on performance characteristics of a host processor comprising a portion of the processing circuit.
48. The receiver of claim 44, wherein  $X/Y$  is approximately .5 or less.
- 55 49. A method for communicating through a channel with an upstream transmitter that is capable of transmitting a data signal at a frame rate T, and a data rate Y, the method comprising the steps of:

- receiving said data signal; and  
 sampling the data signal and converting it to a digital signal; and  
 processing the digital signal at a data rate  $\leq X$  and using said frame rate T, where X is determined prior to initialization of a data transmission and  $X < Y/2$ ; and  
 5 generating a transmission control signal for causing said upstream transmitter to transmit at a data rate no greater than X during a data transmission.
50. The method of claim 49, wherein the control information transmitted to the upstream transceiver includes feedback information indicating that the maximum downstream data transmission data rate is X, even during times when said  
 10 channel is capable of supporting more than said data rate X.
51. The method of claim 49, wherein the feedback information including the data rate X can be controlled by a user of such system.
- 15 52. The method of claim 49, wherein said rate X is determined during a calibration routine.
53. The method of claim 49, wherein said rate X is configurable by a user of such receiver based on performance characteristics of a host processor comprising a portion of the processing circuit.
- 20 54. A method of operating a high speed communications system that is coupled through a channel to an upstream transceiver operating at a maximum data rate Y using a bandwidth F, said method comprising:
- (a) receiving an analog initialization signal having a bandwidth F from the upstream transceiver through the channel; and  
 25 (b) generating a digital signal based on sampling a portion of the analog data transmission signal corresponding to a first frequency bandwidth portion  $f_1$ , where  $f_1 < F$ ; and  
 (c) processing the digital signal to extract data from the digital signal such that an effective receiving rate X (where  $X < Y$ ) is achieved by the system;  
 (d) generating feedback information pertaining to the channel transmission characteristics indicating to the  
 30 upstream transceiver that data rates higher than X should not be used;  
 (e) thereafter receiving an analog data signal transmitted by the upstream transceiver to have a bandwidth  $f_1$ ;  
 (f) repeating steps (b) and (c).
55. The method of claim 54, further including a step prior to step (a): receiving a control signal from a user of such system for determining the effective receiving rate X.  
 35
56. The method of claim 54, further including a step: determining an optimal bandwidth portion  $f_1$  so as to minimize the amount of processing required to extract the data from the digital signal at the receiving rate X.
- 40 57. A high speed communications transceiver for communicating with an upstream transceiver transmitting an analog data transmission signal using M data carrying signals within a bandwidth F through a channel to said system, said transceiver comprising:
- a channel interface circuit for coupling to and receiving said analog data signal from the channel; and  
 45 a front end receiving circuit for sampling the analog data signal and generating a digital signal based on such analog data signal, the digital signal including data from a first frequency bandwidth portion  $f_1$  of said bandwidth F containing N data carrying signals, where  $N < M$ ; and  
 a bus interface circuit for transmitting the digital signal to a host processing device; and  
 wherein the system's performance, including data rate, can be scaled based on modifications to said front end  
 50 receiving circuit or said host processing device so that the sampling of the analog data signal can be increased, and the first frequency bandwidth portion  $f_1$  can also be expanded.
58. The system of claim 57, wherein the front end receiving circuit includes a filter for passing the first frequency bandwidth portion  $f_1$  of said bandwidth F; (ii) and an analog to digital converter.
- 55 59. The system of claim 58, wherein when the modifications include additional bandpass filters for increasing the first frequency bandwidth portion from  $f_1$  to  $f_2$ , where  $F > f_2 > f_1$ , the number of data carrying signals is increased from N to  $N+P$ , where  $P = f_2/f_1 * N$ , and  $N+P < M$ .

60. The system of claim 57, wherein the modifications include adding an additional number of front end circuits  $k$  in the system each with a bandpass frequency  $f_1$  to result in  $N \cdot k$  data carrying signals being included within the digital signal.
- 5 61. The system of claim 57, wherein the first frequency bandwidth portion  $f_1$  is programmable.
62. The system of claim 57, further including a front end transmitting circuit for transmitting control information to cause said upstream transceiver to transmit downstream data only using the  $N$  data carrying signals.
- 10 63. The system of claim 62, wherein the control information transmitted to the upstream transceiver includes feedback information from the host processing device indicating to the upstream transceiver that only  $N$  of the  $M$  data carrying signals are desirable for downstream data transmission, even if said channel is capable of supporting more than  $N$  data carrying signals.
- 15 64. The system of claim 63, wherein the front end transmitting circuit transmits an upstream data transmission using a second frequency bandwidth  $F_2$  and  $L$  upstream data carrying signals, and where  $L < M$ .
65. The system of claim 57, further including a host processor circuit in the host processing device for extracting selected data from the  $N$  data carrying signals.
- 20 66. The system of claim 65, wherein host processor circuit includes a host microprocessor, a programmable memory coupled to the microprocessor, and a data extraction routine located in the memory which can be executed by the microprocessor.
- 25 67. The system of claim 66, wherein the modifications include upgrading said host processing circuit to include additional signal processing power for processing an additional number of data carrying signals.
68. A method of operating a high speed interface between an upstream transceiver and a host processing device at a target data rate, said method comprising:
- 30 (a) receiving an analog initialization signal having a bandwidth  $F$  from the upstream transceiver through a communications channel; and
- (b) generating a digital signal based on sampling a portion of the analog initialization signal corresponding to a first frequency bandpass portion  $f_1$ ;
- 35 (c) transmitting the digital signal to said host processing device so that characteristics of data carrying signals contained within first frequency bandpass portion  $f_1$  can be determined, and a number of such data carrying signals can be configured for use by said host processing device to achieve said target data rate; and
- (e) generating feedback information indicating to the upstream transceiver that bandwidth other than the first frequency bandpass  $f_1$  should not be used for data transmission; and
- 40 (f) receiving an analog data transmission signal having a bandwidth  $f_1$  from said upstream transceiver; and
- (g) generating a digital signal based on sampling the analog data transmission signal; and
- (h) transmitting the digital signal to the host processing device so that it can be processed to extract selected data from the data carrying signals;
- 45 (i) when a data rate increase is required, expanding the first frequency bandpass portion  $f_1$  and returning to step (a).
69. The method of claim 68, further including a step of: determining an optimal size and location of first frequency bandpass portion  $f_1$  so as to minimize the amount of processing required by said host processing device to extract the data from the digital signal.
- 50 70. The method of claim 68, wherein the ratio of  $f_1$  to  $F$  is approximately .5 or less, and a data rate of such interface is controlled by controlling this ratio.
71. The method of claim 68 wherein the analog data transmission is comprised of  $M$  modulated sub-channels within bandwidth  $F$ , and the selected data is contained in  $N$  of the  $M$  sub-channels within first selected frequency bandpass portion  $f_1$ , where  $N < M$ .
- 55 72. The method of claim 68, further including a step: determining an optimal set of  $N$  sub-channels so as to minimize

the amount of processing required to extract the data from the digital signal.

5 73. The method of claim 68, further including a step wherein protocol information pertaining to standards applicable to Asymmetric Digital Subscriber Loops is transmitted by the upstream data transceiver so as to set up a ADSL compatible data link.

10 74. The method of claim 68, wherein during step (i) the first frequency bandpass portion  $f_1$  is increased by the use of additional bandpass filters for increasing the first frequency bandwidth portion from  $f_1$  to  $f_2$ , where  $F > f_2 > f_1$ , so that the selected data is received at an increased rate equal to approximately  $f_2/f_1$ .

15

20

25

30

35

40

45

50

55

**FIGURE 1**

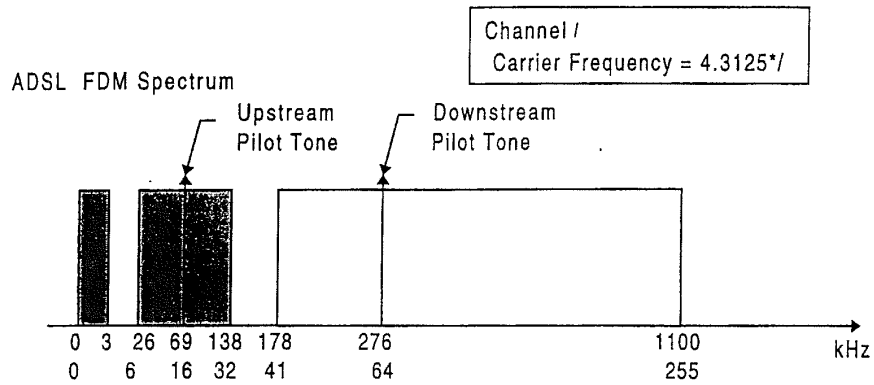

**FIGURE 1B**

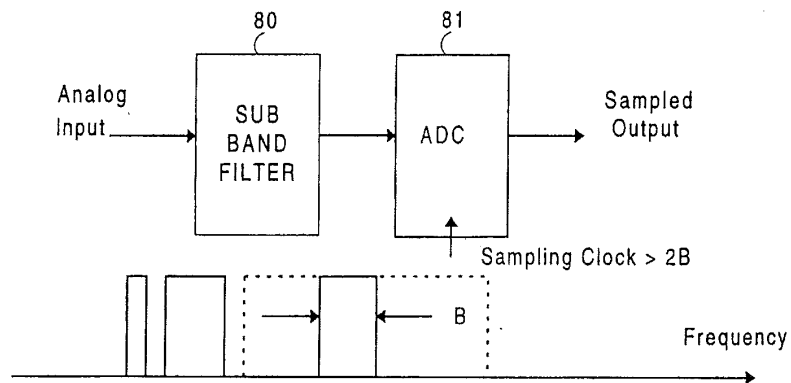

**FIGURE 1C**

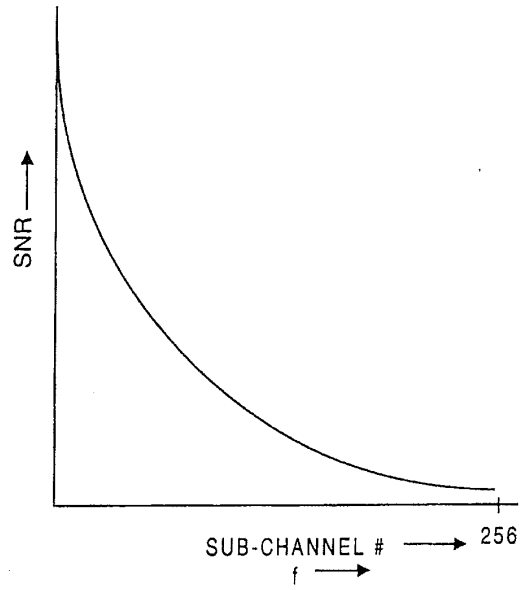

**FIGURE 1D**

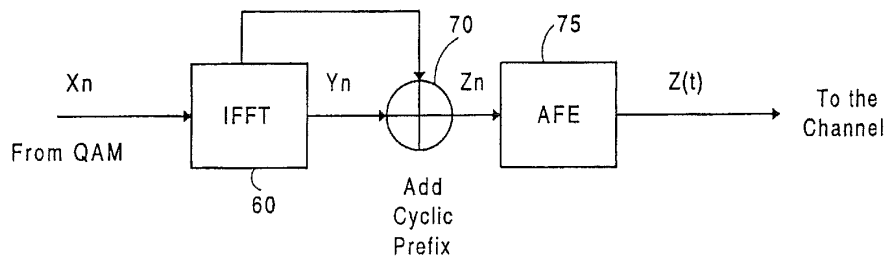



FIGURE 1E

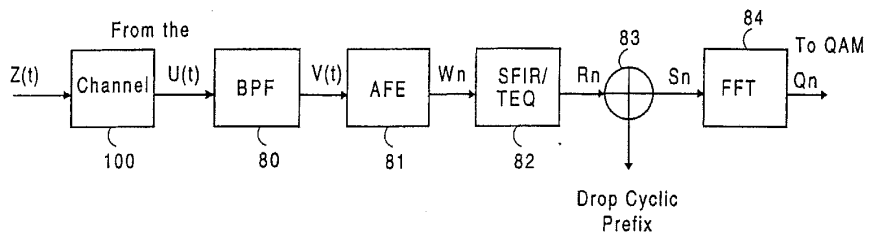
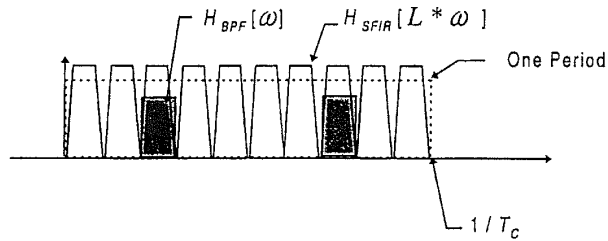

FIGURE 1F



**FIGURE 1G**

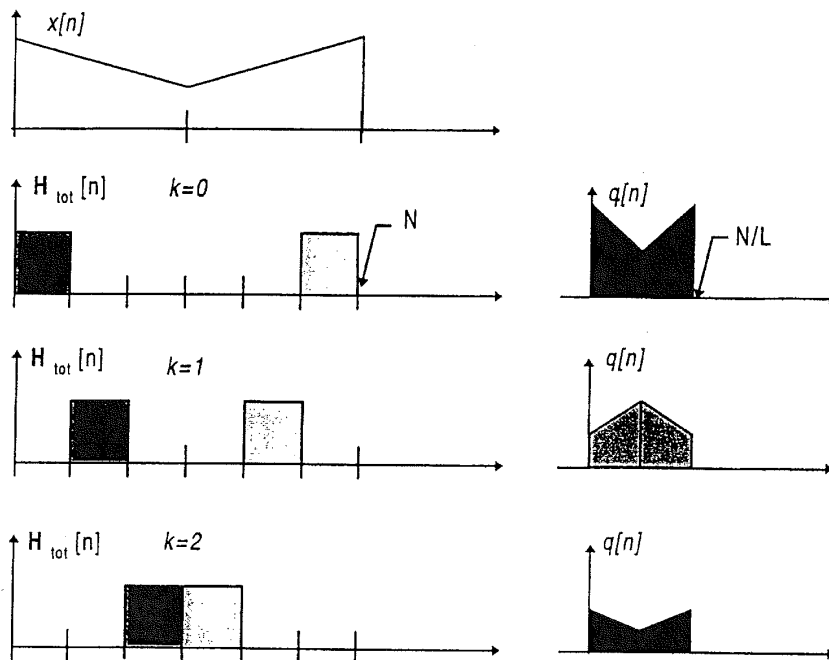

FIGURE 2

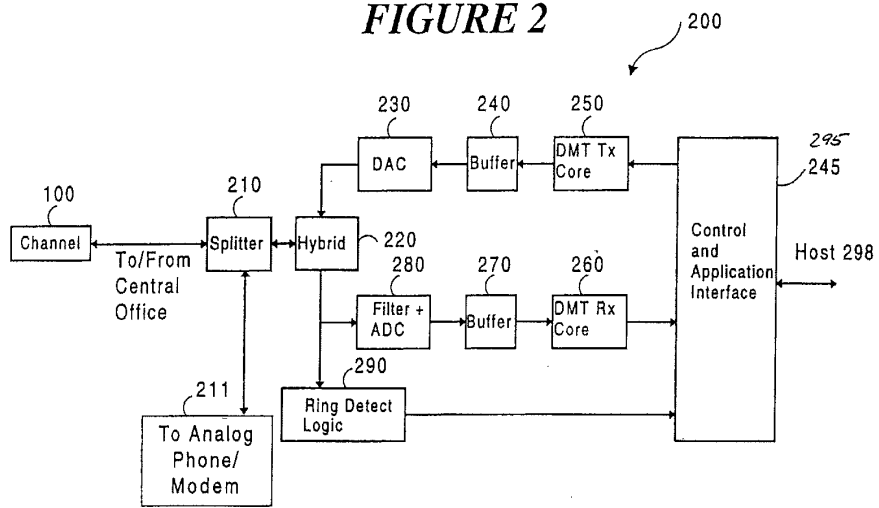

FIGURE 3A

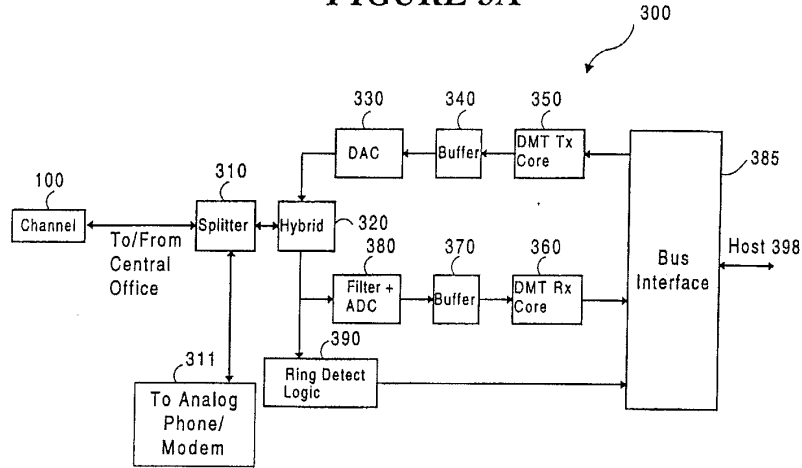

FIGURE 3B

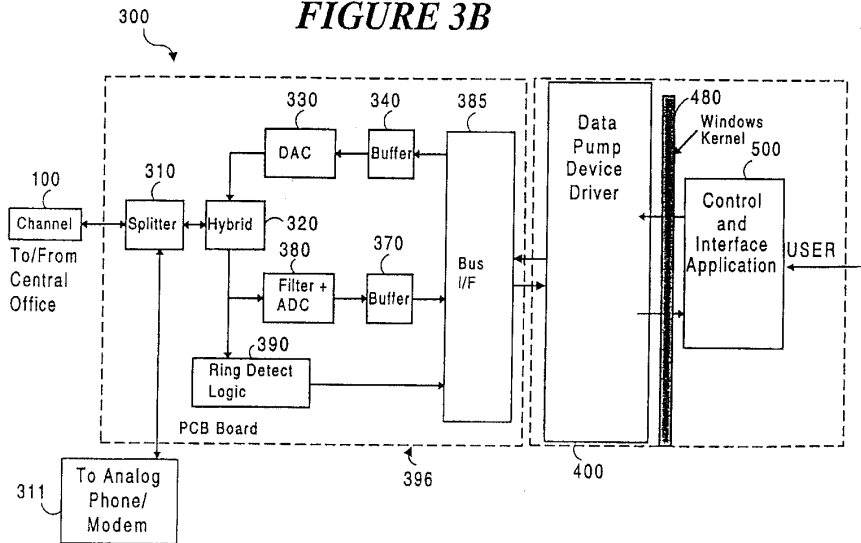
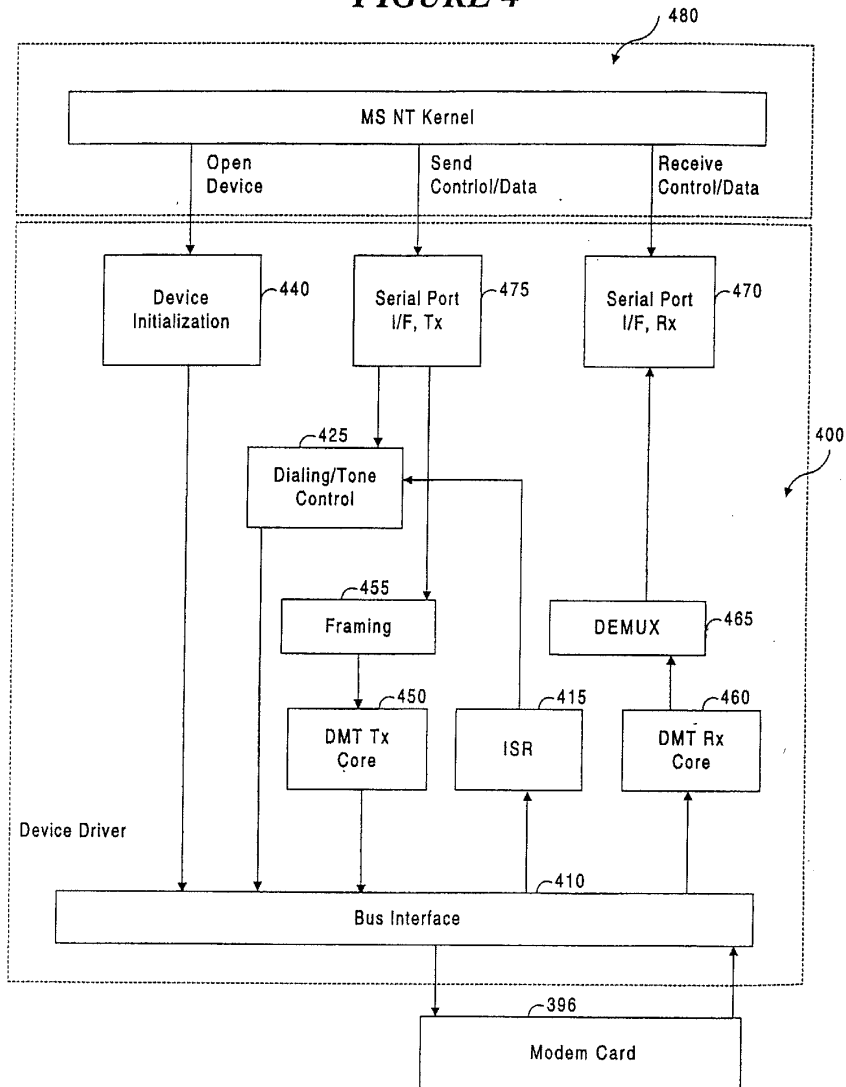

FIGURE 4



**FIGURE 5**

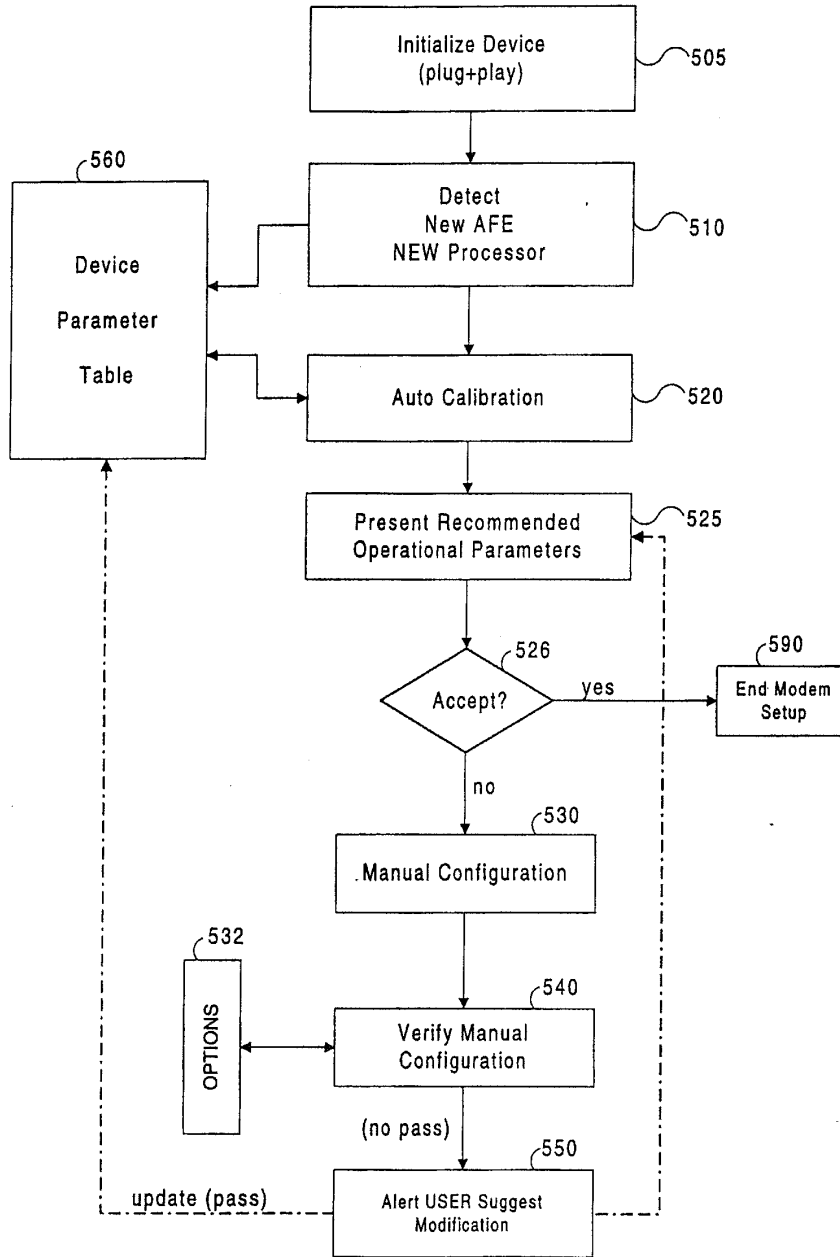
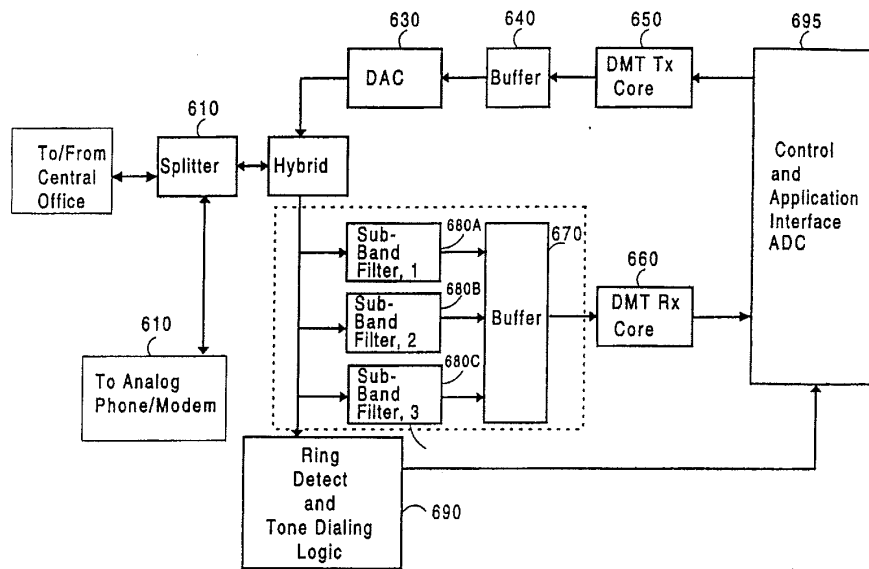

FIGURE 6



## Electronic Acknowledgement Receipt

<b>EFS ID:</b>	7781911
<b>Application Number:</b>	12477742
<b>International Application Number:</b>	
<b>Confirmation Number:</b>	8072
<b>Title of Invention:</b>	SYSTEM AND METHOD FOR ESTABLISHING A DIAGNOSTIC TRANSMISSION MODE AND COMMUNICATING OVER THE SAME
<b>First Named Inventor/Applicant Name:</b>	David M. Krinsky
<b>Customer Number:</b>	62574
<b>Filer:</b>	Jason Vick/Debra Kesner
<b>Filer Authorized By:</b>	Jason Vick
<b>Attorney Docket Number:</b>	5550-2-CON-2-1
<b>Receipt Date:</b>	09-JUN-2010
<b>Filing Date:</b>	03-JUN-2009
<b>Time Stamp:</b>	18:02:18
<b>Application Type:</b>	Utility under 35 USC 111(a)

### Payment information:

Submitted with Payment	no
------------------------	----

### File Listing:

Document Number	Document Description	File Name	File Size(Bytes)/ Message Digest	Multi Part /.zip	Pages (if appl.)
1	Miscellaneous Incoming Letter	Request_For_Examiner_To_Consider_Reference.pdf	5286736 7fdeba2f34feb9b5bfdd5f73babe0721e313915	no	56

### Warnings:

### Information:



This Acknowledgement Receipt evidences receipt on the noted date by the USPTO of the indicated documents, characterized by the applicant, and including page counts, where applicable. It serves as evidence of receipt similar to a Post Card, as described in MPEP 503.

**New Applications Under 35 U.S.C. 111**

If a new application is being filed and the application includes the necessary components for a filing date (see 37 CFR 1.53(b)-(d) and MPEP 506), a Filing Receipt (37 CFR 1.54) will be issued in due course and the date shown on this Acknowledgement Receipt will establish the filing date of the application.

**National Stage of an International Application under 35 U.S.C. 371**

If a timely submission to enter the national stage of an international application is compliant with the conditions of 35 U.S.C. 371 and other applicable requirements a Form PCT/DO/EO/903 indicating acceptance of the application as a national stage submission under 35 U.S.C. 371 will be issued in addition to the Filing Receipt, in due course.

**New International Application Filed with the USPTO as a Receiving Office**

If a new international application is being filed and the international application includes the necessary components for an international filing date (see PCT Article 11 and MPEP 1810), a Notification of the International Application Number and of the International Filing Date (Form PCT/RO/105) will be issued in due course, subject to prescriptions concerning national security, and the date shown on this Acknowledgement Receipt will establish the international filing date of the application.

IN THE UNITED STATES PATENT AND TRADEMARK OFFICE

In Re the Application of: David M. Krinsky	)	Group Art Unit: 2611
	)	
Application No.: 12/477,742	)	Examiner: TRAN, Khanh C.
	)	
Filed: June 3, 2009	)	Confirmation No.: 8072
	)	
Atty. File No.: 5550-2-CON-2-1	)	
	)	

For: MULTICARRIER MODULATION MESSAGING FOR FREQUENCY DOMAIN  
RECEIVED IDLE CHANNEL NOISE INFORMATION

**AMENDMENT AND RESPONSE**

Commissioner for Patents  
P.O. Box 1450  
Alexandria, VA 22313-1450

Sir:

Applicants submit this Amendment and Response to address the Office Action having a mailing date of June 8, 2010. Please credit any overpayment or charge any underpayment to Deposit Account No. 19-1970.

Please amend the above-identified patent application as follows:

**Amendments to the Claims** are shown in the listing of claims which begins on page 2 of this paper.

**Remarks** begin on page 4 of this paper.

**AMENDMENTS TO THE CLAIMS:**

This listing of claims will replace all prior versions, and listings, of claims in the application.

**Listing of Claims:**

1. – 46. (Cancelled)

47. (Previously Presented) A transceiver capable of transmitting test information over a communication channel using multicarrier modulation comprising:

a transmitter portion capable of transmitting a message, wherein the message comprises one or more data variables that represent the test information, wherein bits in the message are modulated onto DMT symbols using Quadrature Amplitude Modulation (QAM) with more than 1 bit per subchannel and wherein at least one data variable of the one or more data variables comprises an array representing frequency domain received idle channel noise information.

48. (Previously Presented) A transceiver capable of receiving test information over a communication channel using multicarrier modulation comprising:

a receiver portion capable of receiving a message, wherein the message comprises one or more data variables that represent the test information, wherein bits in the message were modulated onto DMT symbols using Quadrature Amplitude Modulation (QAM) with more than 1 bit per subchannel and wherein at least one data variable of the one or more data variables comprises an array representing frequency domain received idle channel noise information.

49. (Previously Presented) In a transceiver capable of transmitting test information over a communication channel using multicarrier modulation, a method comprising:

transmitting a message, wherein the message comprises one or more data variables that represent the test information, wherein bits in the message are modulated onto DMT symbols using Quadrature Amplitude Modulation (QAM) with more than 1 bit per subchannel and wherein at least one data variable of the one or more data variables comprises an array representing frequency domain received idle channel noise information.

50. (Previously Presented) In a transceiver capable of receiving test information over a communication channel using multicarrier modulation comprising, a method comprising:  
receiving a message, wherein the message comprises one or more data variables that represent the test information, wherein bits in the message were modulated onto DMT symbols using Quadrature Amplitude Modulation (QAM) with more than 1 bit per subchannel and wherein at least one data variable of the one or more data variables comprises an array representing frequency domain received idle channel noise information.

51. (Previously Presented) A non-transitory computer-readable information storage media having stored thereon instructions that, if executed, cause a transceiver to perform a method comprising:

transmitting a message, wherein the message comprises one or more data variables that represent the test information, wherein bits in the message are modulated onto DMT symbols using Quadrature Amplitude Modulation (QAM) with more than 1 bit per subchannel and wherein at least one data variable of the one or more data variables comprises an array representing frequency domain received idle channel noise information.

52. (Currently Amended) A non-transitory computer-readable information storage media having stored thereon instructions that, if executed, cause a transceiver to perform a method comprising:

receiving a message, wherein the message comprises one or more data variables that represent the test information, wherein bits in the message were modulated onto DMT symbols using Quadrature Amplitude Modulation (QAM) with more than 1 bit per subchannel and wherein at least one data variable of the one or more data variables comprises an array representing frequency domain received idle channel noise information.

**REMARKS**

Applicants request reconsideration of this application as amended.

The Examiner is thanked for the indicated allowed claims.

By this amendment, claim 52 has been amended in accordance with the Examiner's recommendation thereby placing the application in condition for allowance.

A Notice of Allowance is earnestly solicited.

The Commissioner is hereby authorized to charge to Deposit Account No. 19-1970 any fees under 37 C.F.R. §§ 1.16 and 1.17 that may be required by this paper and to credit any overpayment to that Account. If any extension of time is required in connection with the filing of this paper and has not been separately requested, such extension is hereby Petitioned.

Respectfully submitted,

SHERIDAN ROSS P.C.

By: \_\_\_\_\_

Jason H. Vick  
Registration No. 45,285  
1560 Broadway, Suite 1200  
Denver, Colorado 80202-5141  
(303) 863-9700

Date: 9 Jun '10

IN THE UNITED STATES PATENT AND TRADEMARK OFFICE

In Re the Application of: David M. Krinsky	)	Group Art Unit: 2611
	)	
Application No.: 12/477,742	)	Examiner:
	)	
Filed: June 3, 2009	)	Confirmation No.: 8072
	)	
Atty. File No.: 5550-2-CON-2-1	)	
	)	

For: MULTICARRIER MODULATION MESSAGING FOR FREQUENCY DOMAIN  
RECEIVED IDLE CHANNEL NOISE INFORMATION

**SUBMISSION OF SUPPLEMENTAL APPLICATION DATA SHEET**

Commissioner for Patents  
P.O. Box 1450  
Alexandria, VA 22313-1450

Sir:

Attached herewith is a Supplemental Application Data Sheet correcting the typographical errors in the Domestic Priority Data section and updating the title of the application as previously amended in the May 13, 2010 Preliminary Amendment. The Filing Receipt dated June 17, 2009 contained the correct Domestic Priority Data information.

Applicants believe that no fees are due for requesting this correction. However, the Commissioner is hereby authorized to charge any underpayment, or credit any overpayment, to Deposit Account No. 19-1970, in connection with this request.

Respectfully submitted,

SHERIDAN ROSS P.C.

Date: 9 Jun 14

By: 

Jason H. Vick  
Reg. No. 45,285  
1560 Broadway, Suite 1200  
Denver, Colorado 80202  
Telephone: 303-863-9700

Under the Paperwork Reduction Act of 1995, no persons are required to respond to a collection of information unless it contains a valid OMB control number.

<b>Application Data Sheet 37 CFR 1.76</b>		Attorney Docket Number	5550-2-CON-2-1
		Application Number	12/477,742
Title of Invention	<del>SYSTEM AND METHOD FOR ESTABLISHING A DIAGNOSTIC TRANSMISSION MODE AND COMMUNICATING OVER THE SAME</del> Multicarrier Modulation Messaging For Frequency Domain Received Channel Noise Information		
The application data sheet is part of the provisional or nonprovisional application for which it is being submitted. The following form contains the bibliographic data arranged in a format specified by the United States Patent and Trademark Office as outlined in 37 CFR 1.76. This document may be completed electronically and submitted to the Office in electronic format using the Electronic Filing System (EFS) or the document may be printed and included in a paper filed application.			

**Secrecy Order 37 CFR 5.2**

Portions or all of the application associated with this Application Data Sheet may fall under a Secrecy Order pursuant to 37 CFR 5.2 (Paper filers only. Applications that fall under Secrecy Order may not be filed electronically.)

**Applicant Information:**

<b>Applicant 1</b>				
<b>Applicant Authority</b>		<input checked="" type="radio"/> Inventor		<input type="radio"/> Legal Representative under 35 U.S.C. 117
				<input type="radio"/> Party of Interest under 35 U.S.C. 118
<b>Prefix</b>	<b>Given Name</b>	<b>Middle Name</b>	<b>Family Name</b>	<b>Suffix</b>
	David	M.	Krinsky	
<b>Residence Information (Select One)</b>				
		<input checked="" type="radio"/> US Residency		<input type="radio"/> Non US Residency
				<input type="radio"/> Active US Military Service
<b>City</b>	Acton	<b>State/Province</b>	MA	<b>Country of Residence</b>
				US
<b>Citizenship under 37 CFR 1.41(b)</b>		US		
<b>Mailing Address of Applicant:</b>				
<b>Address 1</b>		4 Ayer Road		
<b>Address 2</b>				
<b>City</b>	Acton	<b>State/Province</b>	MA	
<b>Postal Code</b>	01720	<b>Country</b>	US	
<b>Applicant 2</b>				
<b>Applicant Authority</b>		<input checked="" type="radio"/> Inventor		<input type="radio"/> Legal Representative under 35 U.S.C. 117
				<input type="radio"/> Party of Interest under 35 U.S.C. 118
<b>Prefix</b>	<b>Given Name</b>	<b>Middle Name</b>	<b>Family Name</b>	<b>Suffix</b>
	Robert	Edmund	Pizzano	Jr.
<b>Residence Information (Select One)</b>				
		<input checked="" type="radio"/> US Residency		<input type="radio"/> Non US Residency
				<input type="radio"/> Active US Military Service
<b>City</b>	Stoneham	<b>State/Province</b>	MA	<b>Country of Residence</b>
				US
<b>Citizenship under 37 CFR 1.41(b)</b>		US		
<b>Mailing Address of Applicant:</b>				
<b>Address 1</b>		5 Bow Street Court		
<b>Address 2</b>				
<b>City</b>	Stoneham	<b>State/Province</b>	MA	
<b>Postal Code</b>	02180	<b>Country</b>	US	
All Inventors Must Be Listed - Additional Inventor Information blocks may be generated within this form by selecting the <b>Add</b> button. <div style="float: right; border: 1px solid black; padding: 2px 5px;">Add</div>				

**Correspondence Information:**

Enter either Customer Number or complete the Correspondence Information section below.  
 For further information see 37 CFR 1.33(a).

An Address is being provided for the correspondence information of this application.



SUPPLEMENTAL APPLICATION DATA SHEET

PTO/SB/14 (07-07)

Approved for use through 06/30/2010. OMB 0651-0032

U.S. Patent and Trademark Office; U.S. DEPARTMENT OF COMMERCE

Under the Paperwork Reduction Act of 1995, no persons are required to respond to a collection of information unless it contains a valid OMB control number.

<b>Application Data Sheet 37 CFR 1.76</b>		Attorney Docket Number	5550-2-CON-2-1
		Application Number	12/477,742
Title of Invention	<del>SYSTEM AND METHOD FOR ESTABLISHING A DIAGNOSTIC TRANSMISSION MODE AND COMMUNICATING OVER THE SAME</del> <u>Multicarrier Modulation Messaging For Frequency Domain Received Idle Channel Noise Information</u>		
Customer Number	62574		
Email Address	srlaw@sheridanross.com	<input type="button" value="Add Email"/>	<input type="button" value="Remove Email"/>

**Application Information:** Multicarrier Modulation Messaging For Frequency Domain Received Idle Channel Noise Information

Title of the Invention	<del>SYSTEM AND METHOD FOR ESTABLISHING A DIAGNOSTIC TRANSMISSION MODE AND COMMUNICATING OVER THE SAME</del>		
Attorney Docket Number	5550-2-CON-2-1	Small Entity Status Claimed	<input type="checkbox"/>
Application Type	Nonprovisional		
Subject Matter	Utility		
Suggested Class (if any)		Sub Class (if any)	
Suggested Technology Center (if any)			
Total Number of Drawing Sheets (if any)	2	Suggested Figure for Publication (if any)	

**Publication Information:**

Request Early Publication (Fee required at time of Request 37 CFR 1.219)

**Request Not to Publish.** I hereby request that the attached application not be published under 35 U.S.C. 122(b) and certify that the invention disclosed in the attached application **has not and will not** be the subject of an application filed in another country, or under a multilateral international agreement, that requires publication at eighteen months after filing.

**Representative Information:**

Representative information should be provided for all practitioners having a power of attorney in the application. Providing this information in the Application Data Sheet does not constitute a power of attorney in the application (see 37 CFR 1.32). Enter either Customer Number or complete the Representative Name section below. If both sections are completed the Customer Number will be used for the Representative Information during processing.

Please Select One:	<input checked="" type="radio"/> Customer Number	<input type="radio"/> US Patent Practitioner	<input type="radio"/> Limited Recognition (37 CFR 11.9)
Customer Number	62574		

**Domestic Benefit/National Stage Information:**

This section allows for the applicant to either claim benefit under 35 U.S.C. 119(e), 120, 121, or 365(c) or indicate National Stage entry from a PCT application. Providing this information in the application data sheet constitutes the specific reference required by 35 U.S.C. 119(e) or 120, and 37 CFR 1.78(a)(2) or CFR 1.78(a)(4), and need not otherwise be made part of the specification.

Prior Application Status	Pending	<input type="button" value="Remove"/>	
Application Number	Continuity Type	Prior Application Number	Filing Date (YYYY-MM-DD)
	Continuation of	10619691	<del>2009-06-02</del> <u>2003-07-16</u>
Prior Application Status	Patented	<input type="button" value="Remove"/>	

SUPPLEMENTAL APPLICATION DATA SHEET

PTO/SB/14 (07-07)

Approved for use through 06/30/2010. OMB 0651-0032

U.S. Patent and Trademark Office; U.S. DEPARTMENT OF COMMERCE

Under the Paperwork Reduction Act of 1995, no persons are required to respond to a collection of information unless it contains a valid OMB control number.

<b>Application Data Sheet 37 CFR 1.76</b>		Attorney Docket Number	5550-2-CON-2-1
		Application Number	12/477,742
Title of Invention	<del>SYSTEM AND METHOD FOR ESTABLISHING A DIAGNOSTIC TRANSMISSION MODE AND COMMUNICATING OVER THE SAME</del> Multicarrier Modulation Messaging For Frequency Domain Received Channel Noise Information		

Application Number	Continuity Type	Prior Application Number	Filing Date (YYYY-MM-DD)	Patent Number	Issue Date (YYYY-MM-DD)
10619691	Division of	09755173	2001-01-08	6658052	2003-12-02
Prior Application Status		Expired		<input type="button" value="Remove"/>	
Application Number		Continuity Type		Prior Application Number	
09755173		non provisional of		60224308	
Filing Date (YYYY-MM-DD)		2000-08-10			
Prior Application Status		Expired		<input type="button" value="Remove"/>	
Application Number		Continuity Type		Prior Application Number	
09755173		non provisional of		60174865	
Filing Date (YYYY-MM-DD)		<del>2000-07-07</del> <u>2000-01-07</u>			
Additional Domestic Benefit/National Stage Data may be generated within this form by selecting the <b>Add</b> button.					

**Foreign Priority Information:**

This section allows for the applicant to claim benefit of foreign priority and to identify any prior foreign application for which priority is not claimed. Providing this information in the application data sheet constitutes the claim for priority as required by 35 U.S.C. 119(b) and 37 CFR 1.55(a).

<input type="button" value="Remove"/>			
Application Number	Country	Parent Filing Date (YYYY-MM-DD)	Priority Claimed
			<input checked="" type="radio"/> Yes <input type="radio"/> No
Additional Foreign Priority Data may be generated within this form by selecting the <b>Add</b> button.			

**Assignee Information:**

Providing this information in the application data sheet does not substitute for compliance with any requirement of part 3 of Title 37 of the CFR to have an assignment recorded in the Office.

**Assignee 1**

If the Assignee is an Organization check here.   

Organization Name    Aware, Inc.

**Mailing Address Information:**

**Address 1**    40 Middlesex Turnpike

Address 2

**City**    Bedford    **State/Province**    MA

**Country**    US    **Postal Code**    01730-1432

Phone Number    Fax Number

Email Address

Additional Assignee Data may be generated within this form by selecting the **Add** button.

**Signature:**

A signature of the applicant or representative is required in accordance with 37 CFR 1.33 and 10.18. Please see 37 CFR 1.4(d) for the form of the signature.

SUPPLEMENTAL APPLICATION DATA SHEET

PTO/SB/14 (07-07)

Approved for use through 06/30/2010. OMB 0651-0032

U.S. Patent and Trademark Office; U.S. DEPARTMENT OF COMMERCE

Under the Paperwork Reduction Act of 1995, no persons are required to respond to a collection of information unless it contains a valid OMB control number.

<b>Application Data Sheet 37 CFR 1.76</b>		Attorney Docket Number	5550-2-CON-2-1	
		Application Number	12/477,742	
Title of Invention	<del>SYSTEM AND METHOD FOR ESTABLISHING A DIAGNOSTIC TRANSMISSION MODE AND COMMUNICATING OVER THE SAME</del> Multicarrier Modulation Messaging For Frequency Domain Received <del>Idle</del> Channel Noise Information.			
<b>Signature</b>	/Jason H. Vick/		Date (YYYY-MM-DD)	2010-06-09
First Name	Jason H.	Last Name	Vick	Registration Number 45285

This collection of information is required by 37 CFR 1.76. The information is required to obtain or retain a benefit by the public which is to file (and by the USPTO to process) an application. Confidentiality is governed by 35 U.S.C. 122 and 37 CFR 1.14. This collection is estimated to take 23 minutes to complete, including gathering, preparing, and submitting the completed application data sheet form to the USPTO. Time will vary depending upon the individual case. Any comments on the amount of time you require to complete this form and/or suggestions for reducing this burden, should be sent to the Chief Information Officer, U.S. Patent and Trademark Office, U.S. Department of Commerce, P.O. Box 1450, Alexandria, VA 22313-1450. DO NOT SEND FEES OR COMPLETED FORMS TO THIS ADDRESS. **SEND TO: Commissioner for Patents, P.O. Box 1450, Alexandria, VA 22313-1450.**

## Privacy Act Statement

The Privacy Act of 1974 (P.L. 93-579) requires that you be given certain information in connection with your submission of the attached form related to a patent application or patent. Accordingly, pursuant to the requirements of the Act, please be advised that: (1) the general authority for the collection of this information is 35 U.S.C. 2(b)(2); (2) furnishing of the information solicited is voluntary; and (3) the principal purpose for which the information is used by the U.S. Patent and Trademark Office is to process and/or examine your submission related to a patent application or patent. If you do not furnish the requested information, the U.S. Patent and Trademark Office may not be able to process and/or examine your submission, which may result in termination of proceedings or abandonment of the application or expiration of the patent.

The information provided by you in this form will be subject to the following routine uses:

1. The information on this form will be treated confidentially to the extent allowed under the Freedom of Information Act (5 U.S.C. 552) and the Privacy Act (5 U.S.C. 552a). Records from this system of records may be disclosed to the Department of Justice to determine whether the Freedom of Information Act requires disclosure of these records.
2. A record from this system of records may be disclosed, as a routine use, in the course of presenting evidence to a court, magistrate, or administrative tribunal, including disclosures to opposing counsel in the course of settlement negotiations.
3. A record in this system of records may be disclosed, as a routine use, to a Member of Congress submitting a request involving an individual, to whom the record pertains, when the individual has requested assistance from the Member with respect to the subject matter of the record.
4. A record in this system of records may be disclosed, as a routine use, to a contractor of the Agency having need for the information in order to perform a contract. Recipients of information shall be required to comply with the requirements of the Privacy Act of 1974, as amended, pursuant to 5 U.S.C. 552a(m).
5. A record related to an International Application filed under the Patent Cooperation Treaty in this system of records may be disclosed, as a routine use, to the International Bureau of the World Intellectual Property Organization, pursuant to the Patent Cooperation Treaty.
6. A record in this system of records may be disclosed, as a routine use, to another federal agency for purposes of National Security review (35 U.S.C. 181) and for review pursuant to the Atomic Energy Act (42 U.S.C. 218(c)).
7. A record from this system of records may be disclosed, as a routine use, to the Administrator, General Services, or his/her designee, during an inspection of records conducted by GSA as part of that agency's responsibility to recommend improvements in records management practices and programs, under authority of 44 U.S.C. 2904 and 2906. Such disclosure shall be made in accordance with the GSA regulations governing inspection of records for this purpose, and any other relevant (i.e., GSA or Commerce) directive. Such disclosure shall not be used to make determinations about individuals.
8. A record from this system of records may be disclosed, as a routine use, to the public after either publication of the application pursuant to 35 U.S.C. 122(b) or issuance of a patent pursuant to 35 U.S.C. 151. Further, a record may be disclosed, subject to the limitations of 37 CFR 1.14, as a routine use, to the public if the record was filed in an application which became abandoned or in which the proceedings were terminated and which application is referenced by either a published application, an application open to public inspections or an issued patent.
9. A record from this system of records may be disclosed, as a routine use, to a Federal, State, or local law enforcement agency, if the USPTO becomes aware of a violation or potential violation of law or regulation.

## Electronic Acknowledgement Receipt

<b>EFS ID:</b>	7782255
<b>Application Number:</b>	12477742
<b>International Application Number:</b>	
<b>Confirmation Number:</b>	8072
<b>Title of Invention:</b>	SYSTEM AND METHOD FOR ESTABLISHING A DIAGNOSTIC TRANSMISSION MODE AND COMMUNICATING OVER THE SAME
<b>First Named Inventor/Applicant Name:</b>	David M. Krinsky
<b>Customer Number:</b>	62574
<b>Filer:</b>	Jason Vick/Joanne Vos
<b>Filer Authorized By:</b>	Jason Vick
<b>Attorney Docket Number:</b>	5550-2-CON-2-1
<b>Receipt Date:</b>	09-JUN-2010
<b>Filing Date:</b>	03-JUN-2009
<b>Time Stamp:</b>	18:33:04
<b>Application Type:</b>	Utility under 35 USC 111(a)

### Payment information:

Submitted with Payment	no
------------------------	----

### File Listing:

Document Number	Document Description	File Name	File Size(Bytes)/ Message Digest	Multi Part /.zip	Pages (if appl.)
1		AMEND_01.pdf	309426 49edde3d5c74e672a663b6c1e29399af8282fe34	yes	4

Multipart Description/PDF files in .zip description					
Document Description			Start	End	
Amendment/Req. Reconsideration-After Non-Final Reject			1	1	
Claims			2	3	
Applicant Arguments/Remarks Made in an Amendment			4	4	
<b>Warnings:</b>					
<b>Information:</b>					
2	Application Data Sheet	Submission_of_Supplemental_ADS.pdf	76047	no	7
			68cd91584948344b531e0679f018ca0aba5c6f		
<b>Warnings:</b>					
<b>Information:</b>					
This is not an USPTO supplied ADS fillable form					
<b>Total Files Size (in bytes):</b>			385473		
<p><b>This Acknowledgement Receipt evidences receipt on the noted date by the USPTO of the indicated documents, characterized by the applicant, and including page counts, where applicable. It serves as evidence of receipt similar to a Post Card, as described in MPEP 503.</b></p> <p><b><u>New Applications Under 35 U.S.C. 111</u></b>  <b>If a new application is being filed and the application includes the necessary components for a filing date (see 37 CFR 1.53(b)-(d) and MPEP 506), a Filing Receipt (37 CFR 1.54) will be issued in due course and the date shown on this Acknowledgement Receipt will establish the filing date of the application.</b></p> <p><b><u>National Stage of an International Application under 35 U.S.C. 371</u></b>  <b>If a timely submission to enter the national stage of an international application is compliant with the conditions of 35 U.S.C. 371 and other applicable requirements a Form PCT/DO/EO/903 indicating acceptance of the application as a national stage submission under 35 U.S.C. 371 will be issued in addition to the Filing Receipt, in due course.</b></p> <p><b><u>New International Application Filed with the USPTO as a Receiving Office</u></b>  <b>If a new international application is being filed and the international application includes the necessary components for an international filing date (see PCT Article 11 and MPEP 1810), a Notification of the International Application Number and of the International Filing Date (Form PCT/RO/105) will be issued in due course, subject to prescriptions concerning national security, and the date shown on this Acknowledgement Receipt will establish the international filing date of the application.</b></p>					

Under the Paperwork Reduction Act of 1995, no persons are required to respond to a collection of information unless it displays a valid OMB control number.

<b>PATENT APPLICATION FEE DETERMINATION RECORD</b> Substitute for Form PTO-875					Application or Docket Number <b>12/477,742</b>		Filing Date <b>06/03/2009</b>		<input type="checkbox"/> To be Mailed				
<b>APPLICATION AS FILED – PART I</b>							<b>OTHER THAN</b>						
(Column 1)			(Column 2)		SMALL ENTITY <input type="checkbox"/>		OR		SMALL ENTITY				
FOR	NUMBER FILED	NUMBER EXTRA	RATE (\$)	FEE (\$)	OR		RATE (\$)	FEE (\$)					
<input type="checkbox"/> BASIC FEE <small>(37 CFR 1.16(a), (b), or (c))</small>	N/A	N/A	N/A				N/A						
<input type="checkbox"/> SEARCH FEE <small>(37 CFR 1.16(k), (j), or (m))</small>	N/A	N/A	N/A				N/A						
<input type="checkbox"/> EXAMINATION FEE <small>(37 CFR 1.16(o), (p), or (q))</small>	N/A	N/A	N/A				N/A						
TOTAL CLAIMS <small>(37 CFR 1.16(i))</small>	minus 20 =	*	X \$ =				X \$ =						
INDEPENDENT CLAIMS <small>(37 CFR 1.16(h))</small>	minus 3 =	*	X \$ =				X \$ =						
<input type="checkbox"/> APPLICATION SIZE FEE <small>(37 CFR 1.16(s))</small>	If the specification and drawings exceed 100 sheets of paper, the application size fee due is \$250 (\$125 for small entity) for each additional 50 sheets or fraction thereof. See 35 U.S.C. 41(a)(1)(G) and 37 CFR 1.16(s).												
<input type="checkbox"/> MULTIPLE DEPENDENT CLAIM PRESENT <small>(37 CFR 1.16(j))</small>													
* If the difference in column 1 is less than zero, enter "0" in column 2.													
<b>APPLICATION AS AMENDED – PART II</b>							<b>OTHER THAN</b>						
(Column 1)			(Column 2)		(Column 3)		SMALL ENTITY		OR		SMALL ENTITY		
AMENDMENT	<b>06/09/2010</b>	CLAIMS REMAINING AFTER AMENDMENT	HIGHEST NUMBER PREVIOUSLY PAID FOR	PRESENT EXTRA	RATE (\$)	ADDITIONAL FEE (\$)	OR		RATE (\$)	ADDITIONAL FEE (\$)			
	Total <small>(37 CFR 1.16(i))</small>	* 6	Minus	** 20	= 0	X \$ =			OR	X \$52=	0		
	Independent <small>(37 CFR 1.16(h))</small>	* 6	Minus	***6	= 0	X \$ =			OR	X \$220=	0		
	<input type="checkbox"/> Application Size Fee <small>(37 CFR 1.16(s))</small>												
	<input type="checkbox"/> FIRST PRESENTATION OF MULTIPLE DEPENDENT CLAIM <small>(37 CFR 1.16(j))</small>												
					TOTAL ADD'L FEE			OR	TOTAL ADD'L FEE	<b>0</b>			
(Column 1)			(Column 2)		(Column 3)		SMALL ENTITY		OR		SMALL ENTITY		
AMENDMENT	CLAIMS REMAINING AFTER AMENDMENT	HIGHEST NUMBER PREVIOUSLY PAID FOR	PRESENT EXTRA	RATE (\$)	ADDITIONAL FEE (\$)	OR		RATE (\$)	ADDITIONAL FEE (\$)				
	Total <small>(37 CFR 1.16(i))</small>	*	Minus	**	=			X \$ =	OR	X \$ =			
	Independent <small>(37 CFR 1.16(h))</small>	*	Minus	***	=			X \$ =	OR	X \$ =			
	<input type="checkbox"/> Application Size Fee <small>(37 CFR 1.16(s))</small>												
	<input type="checkbox"/> FIRST PRESENTATION OF MULTIPLE DEPENDENT CLAIM <small>(37 CFR 1.16(j))</small>												
					TOTAL ADD'L FEE			OR	TOTAL ADD'L FEE				
* If the entry in column 1 is less than the entry in column 2, write "0" in column 3.													
** If the "Highest Number Previously Paid For" IN THIS SPACE is less than 20, enter "20".													
*** If the "Highest Number Previously Paid For" IN THIS SPACE is less than 3, enter "3".													
The "Highest Number Previously Paid For" (Total or Independent) is the highest number found in the appropriate box in column 1.													
Legal Instrument Examiner: /DENISE HOPKINS/													

This collection of information is required by 37 CFR 1.16. The information is required to obtain or retain a benefit by the public which is to file (and by the USPTO to process) an application. Confidentiality is governed by 35 U.S.C. 122 and 37 CFR 1.14. This collection is estimated to take 12 minutes to complete, including gathering, preparing, and submitting the completed application form to the USPTO. Time will vary depending upon the individual case. Any comments on the amount of time you require to complete this form and/or suggestions for reducing this burden, should be sent to the Chief Information Officer, U.S. Patent and Trademark Office, U.S. Department of Commerce, P.O. Box 1450, Alexandria, VA 22313-1450. DO NOT SEND FEES OR COMPLETED FORMS TO THIS ADDRESS. **SEND TO: Commissioner for Patents, P.O. Box 1450, Alexandria, VA 22313-1450.**  
 If you need assistance in completing the form, call 1-800-PTO-9199 and select option 2.



UNITED STATES PATENT AND TRADEMARK OFFICE

UNITED STATES DEPARTMENT OF COMMERCE  
United States Patent and Trademark Office  
Address: COMMISSIONER FOR PATENTS  
P.O. Box 1450  
Alexandria, Virginia 22313-1450  
www.uspto.gov

APPLICATION NO.	FILING DATE	FIRST NAMED INVENTOR	ATTORNEY DOCKET NO.	CONFIRMATION NO.
12/477,742	06/03/2009	David M. Krinsky	5550-2-CON-2-1	8072
62574	7590	06/08/2010		
Jason H. Vick Sheridan Ross, PC Suite # 1200 1560 Broadway Denver, CO 80202			EXAMINER TRAN, KHANH C	
			ART UNIT	PAPER NUMBER
			2611	
			NOTIFICATION DATE	DELIVERY MODE
			06/08/2010	ELECTRONIC

**Please find below and/or attached an Office communication concerning this application or proceeding.**

The time period for reply, if any, is set in the attached communication.

Notice of the Office communication was sent electronically on above-indicated "Notification Date" to the following e-mail address(es):

[jvick@sheridanross.com](mailto:jvick@sheridanross.com)



<b>Office Action Summary</b>	<b>Application No.</b>	<b>Applicant(s)</b>	
	12/477,742	KRINSKY ET AL.	
	<b>Examiner</b>	<b>Art Unit</b>	
	KHANH C. TRAN	2611	

-- The MAILING DATE of this communication appears on the cover sheet with the correspondence address --

**Period for Reply**

A SHORTENED STATUTORY PERIOD FOR REPLY IS SET TO EXPIRE 3 MONTH(S) OR THIRTY (30) DAYS, WHICHEVER IS LONGER, FROM THE MAILING DATE OF THIS COMMUNICATION.

- Extensions of time may be available under the provisions of 37 CFR 1.136(a). In no event, however, may a reply be timely filed after SIX (6) MONTHS from the mailing date of this communication.
- If NO period for reply is specified above, the maximum statutory period will apply and will expire SIX (6) MONTHS from the mailing date of this communication.
- Failure to reply within the set or extended period for reply will, by statute, cause the application to become ABANDONED (35 U.S.C. § 133). Any reply received by the Office later than three months after the mailing date of this communication, even if timely filed, may reduce any earned patent term adjustment. See 37 CFR 1.704(b).

**Status**

- 1)  Responsive to communication(s) filed on 03 June 2009.
- 2a)  This action is **FINAL**.
- 2b)  This action is non-final.
- 3)  Since this application is in condition for allowance except for formal matters, prosecution as to the merits is closed in accordance with the practice under *Ex parte Quayle*, 1935 C.D. 11, 453 O.G. 213.

**Disposition of Claims**

- 4)  Claim(s) 47-52 is/are pending in the application.
  - 4a) Of the above claim(s) \_\_\_\_\_ is/are withdrawn from consideration.
- 5)  Claim(s) 47-51 is/are allowed.
- 6)  Claim(s) 52 is/are rejected.
- 7)  Claim(s) \_\_\_\_\_ is/are objected to.
- 8)  Claim(s) \_\_\_\_\_ are subject to restriction and/or election requirement.

**Application Papers**

- 9)  The specification is objected to by the Examiner.
- 10)  The drawing(s) filed on 6/3/2009 is/are: a)  accepted or b)  objected to by the Examiner.
  - Applicant may not request that any objection to the drawing(s) be held in abeyance. See 37 CFR 1.85(a).
  - Replacement drawing sheet(s) including the correction is required if the drawing(s) is objected to. See 37 CFR 1.121(d).
- 11)  The oath or declaration is objected to by the Examiner. Note the attached Office Action or form PTO-152.

**Priority under 35 U.S.C. § 119**

- 12)  Acknowledgment is made of a claim for foreign priority under 35 U.S.C. § 119(a)-(d) or (f).
    - a)  All   b)  Some \* c)  None of:
      - 1.  Certified copies of the priority documents have been received.
      - 2.  Certified copies of the priority documents have been received in Application No. \_\_\_\_\_.
      - 3.  Copies of the certified copies of the priority documents have been received in this National Stage application from the International Bureau (PCT Rule 17.2(a)).
- \* See the attached detailed Office action for a list of the certified copies not received.

**Attachment(s)**

- 1)  Notice of References Cited (PTO-892)
- 2)  Notice of Draftsperson's Patent Drawing Review (PTO-948)
- 3)  Information Disclosure Statement(s) (PTO/SB/08)
  - Paper No(s)/Mail Date \_\_\_\_\_.
- 4)  Interview Summary (PTO-413)
  - Paper No(s)/Mail Date \_\_\_\_\_.
- 5)  Notice of Informal Patent Application
- 6)  Other: \_\_\_\_\_.

### DETAILED ACTION

1. The Preliminary Amendment filed on 5/13/2010 has been entered. Claims 47-52 are still pending in this Office action.

#### ***Claim Rejections - 35 USC § 101***

35 U.S.C. 101 reads as follows:

Whoever invents or discovers any new and useful process, machine, manufacture, or composition of matter, or any new and useful improvement thereof, may obtain a patent therefor, subject to the conditions and requirements of this title.

2. Claim 52 is rejected under 35 U.S.C. 101 because the claimed invention is directed to non-statutory subject matter. Claim is recited to a computer-readable information storage media. Since the original disclosure is silent about the claimed subject matter, the recited subject matter “computer-readable information storage media” could be interpreted as broadly as their terms reasonably allow. In view of that, the broadest reasonable interpretation of a claim drawn to computer-readable information storage media typically covers forms of ***non-transitory tangible media*** and ***transitory propagating signals per se*** in view of the ordinary and customary meaning of computer readable information storage media. Therefore, the recited claimed subject matter is directed to non-statutory subject matter.

***Examiner’s Suggestion:*** The subject matter “computer-readable information storage media” should be changed to “non-transitory computer-readable information storage media” to overcome 35 U.S.C 101 rejection.

***Allowable Subject Matter***

3. Claim 47-51 are allowed.

***Conclusion***

4. The prior art made of record and not relied upon is considered pertinent to applicant's disclosure.

Liang et al. U.S. Patent 6,445,773 B1.

Chow U.S. Patent 6,249,543 B1.

5. Any inquiry concerning this communication or earlier communications from the examiner should be directed to KHANH C. TRAN whose telephone number is (571)272-3007. The examiner can normally be reached on Monday - Friday from 08:00 AM - 05:00 PM.

If attempts to reach the examiner by telephone are unsuccessful, the examiner's supervisor, Shuwang Liu can be reached on 571-272-3036. The fax phone number for the organization where this application or proceeding is assigned is 571-273-8300.

Information regarding the status of an application may be obtained from the Patent Application Information Retrieval (PAIR) system. Status information for published applications may be obtained from either Private PAIR or Public PAIR. Status information for unpublished applications is available through Private PAIR only. For more information about the PAIR system, see <http://pair-direct.uspto.gov>. Should you have questions on access to the Private PAIR system, contact the Electronic Business Center (EBC) at 866-217-9197 (toll-free). If you would like assistance from a USPTO Customer Service Representative or access to the automated information system, call 800-786-9199 (IN USA OR CANADA) or 571-272-1000.

KCT

*/KHANH C. TRAN/  
Primary Examiner, Art Unit 2611*

<b>Notice of References Cited</b>	Application/Control No. 12/477,742	Applicant(s)/Patent Under Reexamination KRINSKY ET AL.	
	Examiner KHANH C. TRAN	Art Unit 2611	Page 1 of 1

**U.S. PATENT DOCUMENTS**

*	Document Number Country Code-Number-Kind Code	Date MM-YYYY	Name	Classification
*	A US-6,445,773	09-2002	Liang et al.	379/1.04
*	B US-6,249,543	06-2001	Chow, Jacky S.	375/219
C	US-			
D	US-			
E	US-			
F	US-			
G	US-			
H	US-			
I	US-			
J	US-			
K	US-			
L	US-			
M	US-			

**FOREIGN PATENT DOCUMENTS**

*	Document Number Country Code-Number-Kind Code	Date MM-YYYY	Country	Name	Classification
N					
O					
P					
Q					
R					
S					
T					

**NON-PATENT DOCUMENTS**

*	U	V	W	X
	Include as applicable: Author, Title Date, Publisher, Edition or Volume, Pertinent Pages)			

\*A copy of this reference is not being furnished with this Office action. (See MPEP § 707.05(a).)  
Dates in MM-YYYY format are publication dates. Classifications may be US or foreign.

<b>Index of Claims</b> 	<b>Application/Control No.</b> 12477742	<b>Applicant(s)/Patent Under Reexamination</b> KRINSKY ET AL.
	<b>Examiner</b> KHANH C TRAN	<b>Art Unit</b> 2611

✓	<b>Rejected</b>	-	<b>Cancelled</b>	N	<b>Non-Elected</b>	A	<b>Appeal</b>
=	<b>Allowed</b>	÷	<b>Restricted</b>	I	<b>Interference</b>	O	<b>Objected</b>

<input type="checkbox"/> Claims renumbered in the same order as presented by applicant			<input type="checkbox"/> CPA			<input type="checkbox"/> T.D.			<input type="checkbox"/> R.1.47		
CLAIM		DATE									
Final	Original	06/03/2010									
	1	-									
	2	-									
	3	-									
	4	-									
	5	-									
	6	-									
	7	-									
	8	-									
	9	-									
	10	-									
	11	-									
	12	-									
	13	-									
	14	-									
	15	-									
	16	-									
	17	-									
	18	-									
	19	-									
	20	-									
	21	-									
	22	-									
	23	-									
	24	-									
	25	-									
	26	-									
	27	-									
	28	-									
	29	-									
	30	-									
	31	-									
	32	-									
	33	-									
	34	-									
	35	-									
	36	-									

<b>Index of Claims</b>  	<b>Application/Control No.</b>  12477742	<b>Applicant(s)/Patent Under Reexamination</b>  KRINSKY ET AL.
	<b>Examiner</b>  KHANH C TRAN	<b>Art Unit</b>  2611

✓	<b>Rejected</b>	-	<b>Cancelled</b>	N	<b>Non-Elected</b>	A	<b>Appeal</b>
=	<b>Allowed</b>	÷	<b>Restricted</b>	I	<b>Interference</b>	O	<b>Objected</b>

<input type="checkbox"/> Claims renumbered in the same order as presented by applicant			<input type="checkbox"/> CPA			<input type="checkbox"/> T.D.			<input type="checkbox"/> R.1.47		
CLAIM			DATE								
Final	Original	06/03/2010									
	37	-									
	38	-									
	39	-									
	40	-									
	41	-									
	42	-									
	43	-									
	44	-									
	45	-									
	46	-									
	47	=									
	48	=									
	49	=									
	50	=									
	51	=									
	52	✓									

<b>Search Notes</b>  	<b>Application/Control No.</b> 12477742	<b>Applicant(s)/Patent Under Reexamination</b> KRINSKY ET AL.
	<b>Examiner</b> KHANH C TRAN	<b>Art Unit</b> 2611

SEARCHED			
Class	Subclass	Date	Examiner

SEARCH NOTES		
Search Notes	Date	Examiner
Update Searches on the Parent Cases US Patent 6,658,052 & US Patent 7,570,686	6/3/2010	KCT

INTERFERENCE SEARCH			
Class	Subclass	Date	Examiner

	/KHANH C TRAN/ Primary Examiner.Art Unit 2611
--	--



**UNITED STATES PATENT AND TRADEMARK OFFICE**

UNITED STATES DEPARTMENT OF COMMERCE  
 United States Patent and Trademark Office  
 Address: COMMISSIONER FOR PATENTS  
 P.O. Box 1450  
 Alexandria, Virginia 22313-1450  
 www.uspto.gov

**BIB DATA SHEET**
**CONFIRMATION NO. 8072**

SERIAL NUMBER	FILING or 371(c) DATE RULE	CLASS	GROUP ART UNIT	ATTORNEY DOCKET NO.		
12/477,742	06/03/2009	375	2611	5550-2-CON-2-1		
<b>APPLICANTS</b> David M. Krinsky, Acton, MA; Robert Edmund Pizzano Jr., Stoneham, MA;						
<b>** CONTINUING DATA *****</b> This application is a CON of 10/619,691 07/16/2003 PAT 7,570,686 YES * which is a DIV of 09/755,173 01/08/2001 PAT 6,658,052 YES which claims benefit of 60/224,308 08/10/2000 YES and claims benefit of 60/174,865 01/07/2000 YES * (*)Data provided by applicant is not consistent with PTO records.						
<b>** FOREIGN APPLICATIONS ***** NO</b> /KCT/ /KCT/						
<b>** IF REQUIRED, FOREIGN FILING LICENSE GRANTED **</b> 06/10/2009						
Foreign Priority claimed <input type="checkbox"/> Yes <input checked="" type="checkbox"/> No 35 USC 119(a-d) conditions met <input type="checkbox"/> Yes <input type="checkbox"/> No Verified and /KHANH C TRAN/ Acknowledged Examiner's Signature		<input type="checkbox"/> Met after Allowance KCT Initials	<b>STATE OR COUNTRY</b> MA	<b>SHEETS DRAWINGS</b> 2	<b>TOTAL CLAIMS</b> 6 <del>3</del>	<b>INDEPENDENT CLAIMS</b> 6 <del>3</del>
<b>ADDRESS</b> Jason H. Vick Sheridan Ross, PC Suite # 1200 1560 Broadway Denver, CO 80202 UNITED STATES						
<b>TITLE</b> SYSTEM AND METHOD FOR ESTABLISHING A DIAGNOSTIC TRANSMISSION MODE AND COMMUNICATING OVER THE SAME						
<b>FILING FEE RECEIVED</b> 1750	FEES: Authority has been given in Paper No. _____ to charge/credit DEPOSIT ACCOUNT No. _____ for following:			<input type="checkbox"/> All Fees <input type="checkbox"/> 1.16 Fees (Filing) <input type="checkbox"/> 1.17 Fees (Processing Ext. of time) <input type="checkbox"/> 1.18 Fees (Issue) <input type="checkbox"/> Other _____ <input type="checkbox"/> Credit		

Substitute for form 1449A/PTO				<b>Complete if Known</b>	
<b>INFORMATION DISCLOSURE STATEMENT BY APPLICANT</b>				Application Number	12/477,742
				Filing Date	June 3, 2009
				First Named Inventor	David M. Krinsky
				Art Unit	2611
				Examiner Name	<del>Not yet assigned</del> KHANH C. TRAN
Sheet	1	of	4	Attorney Docket Number	5550-2-CON-2-1

U.S. PATENT DOCUMENTS					
Examiner Initials*	Cite No. <sup>1</sup>	Document Number Number-kind Code <sup>2</sup> (if known)	Publication Date MM-DD-YYYY	Name of Patentee of Applicant of Cited Document	Pages, Columns, Lines, Where Relevant Passages or Relevant Figures Appear
/KCT/	1	4385384	05/24/83	Rosbury et al.	
	2	4566100	01/21/86	Mizuno et al.	
	3	5128619	07/07/92	Bjork et al.	
	4	5361293	11/01/94	Czerwiec	
	5	5608643	03/04/97	Wichter et al.	
	6	5864602	01/26/99	Needle	
	7	5964891	10/12/99	Caswell et al.	
	8	6073179	06/06/00	Liu et al.	
	9	6075821	06/13/00	Kao et al.	
	10	6175934	01/16/01	Hershey et al.	
	11	6219378	04/17/01	Wu	
	12	6404774	06/11/02	Jenness	
	13	6411678	06/25/02	Tomlinson, Jr. et al.	
	14	6449307	09/10/02	Ishikawa et al.	
	15	6512789	01/28/03	Mirfakhraei	
	16	6631120	10/07/03	Milbrandt	
	17	6633545	10/14/03	Milbrandt	
	18	6636603	10/21/03	Milbrandt	
	19	6725176	04/20/04	Long et al.	
	20	6658052	12/02/03	Krinsky et al.	
/KCT/	21	7570686	08/04/09	Krinsky et al.	

FOREIGN PATENT DOCUMENTS						
Examiner Initials*	Cite No. <sup>1</sup>	Foreign Patent Document Country Code <sup>3</sup> ; Number <sup>4</sup> ; Kind Code <sup>5</sup> (if known)	Publication Date MM-DD-YYYY	Name of Patentee or Applicant of Cited Document	Pages, Columns, Lines, Where Relevant Passages or Relevant Figures Appear	T <sup>6</sup>
	22	EP 0889615	01/07/99	INTEGRATED TELECOM EXPRESS		

Examiner Signature	/Khanh Tran/ (06/03/2010)	Date Considered	06/03/2010
--------------------	---------------------------	-----------------	------------

\*EXAMINER: Initial if reference is considered, whether or not citation is in conformance and not considered. Include copy of this form with next communication to applicant.

ALL REFERENCES CONSIDERED EXCEPT WHERE LINED THROUGH. /KCT/

Substitute for form 1449A/PTO				<b>Complete if Known</b>	
<b>INFORMATION DISCLOSURE STATEMENT BY APPLICANT</b>				Application Number	12/477,742
				Filing Date	June 3, 2009
				First Named Inventor	David M. Krinsky
				Art Unit	2611
				Examiner Name	Not yet assigned <b>KHANH C. TRAN</b>
Sheet	2	of	4	Attorney Docket Number	5550-2-CON-2-1

/KCT/	23	GB 2303032	02/05/97	SAMSUNG ELECTRONICS CO LTD		
	24	JP Hei6(1994)-003956	01/12/94	TELEBIT CORPORATION		(believed to correspond to WO 86/07223 disclosed herein)
	25	JP-A-Hei10(1998)-513622	12/22/98	ADC TELECOMMUNICATIONS INC		(Translated abstract)
	26	JP-A-Hei11(1999)-261665	09/24/99	MATSUSHITA GRAPHIC COMMUNIC		(Translated abstract)
	27	JP-A-Hei11(1999)-317723	11/16/99	MOTOROLA INC		(Translated abstract)
	28	JP-A-Hei11(1999)-508417	07/21/99	ERICSSON TELEFON AB L M		(Translated abstract)
	29	WO 00/64130	10/26/00	TERADYNE INC		
	30	WO 86/07223	12/04/86	TELEBIT CORPORATION		(believed to correspond to JP Hei6(1994)-003956 disclosed herein)
	31	WO 97/01900	01/16/97	ERICSSON AUSTRIA AG		
	32	WO 99/020027	04/22/99	Aware		
	33	WO 99/26375	05/27/99	TEKTRONIX INC		
/KCT/	34	WO 99/63427	12/09/99	GTE LABORATORIES INC		

Examiner Signature	/Khanh Tran/ (06/03/2010)	Date Considered	06/03/2010
--------------------	---------------------------	-----------------	------------

\*EXAMINER: Initial if reference is considered, whether or not citation is in conformance and not considered. Include copy of this form with next communication to applicant.

ALL REFERENCES CONSIDERED EXCEPT WHERE LINED THROUGH. /KCT/

Substitute for form 1449A/PTO		<b>Complete if Known</b>	
<b>INFORMATION DISCLOSURE STATEMENT BY APPLICANT</b>		Application Number	12/477,742
		Filing Date	June 3, 2009
		First Named Inventor	David M. Krinsky
		Art Unit	2611
		Examiner Name	<del>Not yet assigned</del> KHANH C. TRAN
		Attorney Docket Number	5550-2-CON-2-1
Sheet	3	of	4

OTHER ART (Including Author, Title, Date, Pertinent Pages, etc.)		
Examiner Initials*	Cite No. <sup>1</sup>	
/KCT/	35	Boets P. et al.: "Modeling Aspect of Transmission Line Networks" Proceedings Of The Instrumentation And Measurement Technology Conference, US, New York, IEEE, May 12, 1992, pp. 137-141, XP000343913 ISBN: 0-7803-0640-6
	36	Cioffi, John M., ADSL Maintenance with DMT, T1E1.4 ADSL Project, Amati Communications Corporation, December 1, 1992, pages 1-14
	37	Lewis L. et al. "Extending Trouble Ticket System to Fault Diagnostics" IEEE Network, IEEE Inc. New York, US, Nov. 1, 1993, pp. 44-51, XP 000575228
	38	International Search Report for PCT/US01/00418 dated Jul. 16, 2001; 4 pages (5550-2-PCT)
	39	Written Opinion for International (PCT) Patent Application No. PCT/US01/00418, completed March 9, 2002 (5550-2-PCT)
	40	International Preliminary Examination Report for International (PCT) Patent Application No. PCT/US01/00418, completed March 9, 2002 (5550-2-PCT)
	41	PCT International Search Report dated Oct. 9, 2002 for PCT/US01/41653 (5550-2-PCT-3)
	42	Examiner's First Report for Australian Patent Application No. 27669/01, mailed April 2, 2004 (Attorney's Ref. No. 5550-2-PAU)
	43	Notice of Acceptance for Australian Patent Application No. 27669/01, mailed August 6, 2004 (Attorney's Ref. No. 5550-2-PAU)
	44	Examiner's First Report for Australian Patent Application No. 2004203321, mailed November 16, 2006 (5550-2-PAU4)
	45	Examiner's First Report for Australian Patent Application No. 2008203520, mailed March 9, 2009 (5550-2-PAU4-DIV)
	46	Notice of Acceptance for Australian Patent Application No. 2008203520, mailed July 9, 2009 (5550-2-PAU4-DIV)
	47	Official Action for Canadian Patent Application No. 2,394,491, mailed November 24, 2009 (Attorney's Ref. No. 5550-2-PCA)
/KCT/	48	Official Action for European Patent Application No. 01901808.4, mailed December 1, 2004 (Attorney's Ref. No. 5550-2-PEP)

Examiner Signature	/Khanh Tran/ (06/03/2010)	Date Considered	06/03/2010
--------------------	---------------------------	-----------------	------------

\*EXAMINER: Initial if reference is considered, whether or not citation is in conformance and not considered. Include copy of this form with next communication to applicant.

ALL REFERENCES CONSIDERED EXCEPT WHERE LINED THROUGH. /KCT/

Substitute for form 1449A/PTO				<b>Complete if Known</b>	
<b>INFORMATION DISCLOSURE STATEMENT BY APPLICANT</b>				Application Number	12/477,742
				Filing Date	June 3, 2009
				First Named Inventor	David M. Krinsky
				Art Unit	2611
				Examiner Name	<del>Not yet assigned</del> KHANH C. TRAN
Sheet	4	of	4	Attorney Docket Number	5550-2-CON-2-1

/KCT/	49	Official Action for European Patent Application No. 01901808.4, mailed September 14, 2005 (Attorney's Ref. No. 5550-2-PEP)
/KCT/	50	Communication about intention to grant a European patent for European Patent Application No. 01901808.4, mailed May 15, 2006 (Attorney's Ref. No. 5550-2-PEP)
/KCT/	51	European Search Report for European Patent Application No. EP 06022008 completed January 8, 2007 (5550-2-PEP5)
/KCT/	52	Notification of Reasons (including translation) for Refusal for Japanese Patent Application No. 2001-552611, Dispatched Date: December 7, 2009 (Attorney's Ref. No. 5550-2-PJP)
/KCT/	53	Decision to Grant Patent (including translation) For Korean Patent Application No. 10-2002-7008794, dated December 1, 2006 (Attorney's Ref. No. 5550-2-PKR)

Examiner Signature	/Khanh Tran/ (06/03/2010)	Date Considered	06/03/2010
--------------------	---------------------------	-----------------	------------

\*EXAMINER: Initial if reference is considered, whether or not citation is in conformance and not considered. Include copy of this form with next communication to applicant.

ALL REFERENCES CONSIDERED EXCEPT WHERE LINED THROUGH. /KCT/

IN THE UNITED STATES PATENT AND TRADEMARK OFFICE

In Re the Application of: David M. Krinsky	)	Group Art Unit: 2611
	)	
Application No.: 12/477,742	)	Examiner:
	)	
Filed: June 3, 2009	)	Confirmation No.: 8072
	)	
Atty. File No.: 5550-2-CON-2-1	)	
	)	

For: MULTICARRIER MODULATION MESSAGING FOR FREQUENCY DOMAIN  
RECEIVED IDLE CHANNEL NOISE INFORMATION (As Amended)

Commissioner for Patents  
P.O. Box 1450  
Alexandria, VA 22313

**PRELIMINARY AMENDMENT**

Dear Sir:

Prior to the initial review of the above-identified patent application by the Examiner, please enter the following Preliminary Amendment. Although Applicants do not believe that any fees are due based upon the filing of this Preliminary Amendment, please charge any such fees to Deposit Account 19-1970.

Please amend the above-identified patent application as follows:

**Amendments to the Specification** begin on page 2 of this paper.

**Amendments to the Claims** are shown in the listing of claims which begin on page 3 of this paper.

**Remarks** begin on page 5 of this paper.

**AMENDMENTS TO THE SPECIFICATION**

Please change the title to read as follows:

MULTICARRIER MODULATION MESSAGING FOR FREQUENCY DOMAIN RECEIVED  
IDLE CHANNEL NOISE INFORMATION

**AMENDMENTS TO THE CLAIMS:**

This listing of claims will replace all prior versions, and listings, of claims in the application.

**Listing of Claims:**

1. – 46. (Cancelled)

47. (New) A transceiver capable of transmitting test information over a communication channel using multicarrier modulation comprising:

a transmitter portion capable of transmitting a message, wherein the message comprises one or more data variables that represent the test information, wherein bits in the message are modulated onto DMT symbols using Quadrature Amplitude Modulation (QAM) with more than 1 bit per subchannel and wherein at least one data variable of the one or more data variables comprises an array representing frequency domain received idle channel noise information.

48. (New) A transceiver capable of receiving test information over a communication channel using multicarrier modulation comprising:

a receiver portion capable of receiving a message, wherein the message comprises one or more data variables that represent the test information, wherein bits in the message were modulated onto DMT symbols using Quadrature Amplitude Modulation (QAM) with more than 1 bit per subchannel and wherein at least one data variable of the one or more data variables comprises an array representing frequency domain received idle channel noise information.

49. (New) In a transceiver capable of transmitting test information over a communication channel using multicarrier modulation, a method comprising:

transmitting a message, wherein the message comprises one or more data variables that represent the test information, wherein bits in the message are modulated onto DMT symbols using Quadrature Amplitude Modulation (QAM) with more than 1 bit per subchannel and wherein at least one data variable of the one or more data variables comprises an array representing frequency domain received idle channel noise information.



50. (New) In a transceiver capable of receiving test information over a communication channel using multicarrier modulation comprising, a method comprising: receiving a message, wherein the message comprises one or more data variables that represent the test information, wherein bits in the message were modulated onto DMT symbols using Quadrature Amplitude Modulation (QAM) with more than 1 bit per subchannel and wherein at least one data variable of the one or more data variables comprises an array representing frequency domain received idle channel noise information.

51. (New) A non-transitory computer-readable information storage media having stored thereon instructions that, if executed, cause a transceiver to perform a method comprising: transmitting a message, wherein the message comprises one or more data variables that represent the test information, wherein bits in the message are modulated onto DMT symbols using Quadrature Amplitude Modulation (QAM) with more than 1 bit per subchannel and wherein at least one data variable of the one or more data variables comprises an array representing frequency domain received idle channel noise information.

52. (New) A computer-readable information storage media having stored thereon instructions that, if executed, cause a transceiver to perform a method comprising: receiving a message, wherein the message comprises one or more data variables that represent the test information, wherein bits in the message were modulated onto DMT symbols using Quadrature Amplitude Modulation (QAM) with more than 1 bit per subchannel and wherein at least one data variable of the one or more data variables comprises an array representing frequency domain received idle channel noise information.

**REMARKS/ARGUMENTS**

By this amendment, claim 1-46 have been cancelled without prejudice or disclaimer in favor of the newly presented claims 47-52 that are directed toward more specific aspects of the invention.

Applicant requests examination on the merits.

Applicant believes that the pending claims are in condition for allowance and such disposition is respectfully requested. In the event that a telephone conversation would further prosecution and/or expedite allowance, the Examiner is invited to contact the undersigned.

The Commissioner is hereby authorized to charge to Deposit Account No. 19-1970 any fees under 37 C.F.R. §§ 1.16 and 1.17 that may be required by this paper and to credit any overpayment to that Account. If any extension of time is required in connection with the filing of this paper and has not been separately requested, such extension is hereby Petitioned.

Respectfully submitted,

SHERIDAN ROSS P.C.

By: \_\_\_\_\_

~~Jason H. Vick~~  
Registration No. 45,285  
1560 Broadway, Suite 1200  
Denver, Colorado 80202-5141  
(303) 863-9700

Date: 13 Mar '10

## Electronic Patent Application Fee Transmittal

<b>Application Number:</b>	12477742			
<b>Filing Date:</b>	03-Jun-2009			
<b>Title of Invention:</b>	SYSTEM AND METHOD FOR ESTABLISHING A DIAGNOSTIC TRANSMISSION MODE AND COMMUNICATING OVER THE SAME			
<b>First Named Inventor/Applicant Name:</b>	David M. Krinsky			
<b>Filer:</b>	Jason Vick/Joanne Vos			
<b>Attorney Docket Number:</b>	5550-2-CON-2-1			
Filed as Large Entity				
<b>Utility under 35 USC 111(a) Filing Fees</b>				
<b>Description</b>	<b>Fee Code</b>	<b>Quantity</b>	<b>Amount</b>	<b>Sub-Total in USD(\$)</b>
<b>Basic Filing:</b>				
<b>Pages:</b>				
<b>Claims:</b>				
Independent claims in excess of 3	1201	3	220	660
<b>Miscellaneous-Filing:</b>				
<b>Petition:</b>				
<b>Patent-Appeals-and-Interference:</b>				
<b>Post-Allowance-and-Post-Issuance:</b>				
<b>Extension-of-Time:</b>				

Description	Fee Code	Quantity	Amount	Sub-Total in USD(\$)
<b>Miscellaneous:</b>				
<b>Total in USD (\$)</b>				<b>660</b>

## Electronic Acknowledgement Receipt

<b>EFS ID:</b>	7608356
<b>Application Number:</b>	12477742
<b>International Application Number:</b>	
<b>Confirmation Number:</b>	8072
<b>Title of Invention:</b>	SYSTEM AND METHOD FOR ESTABLISHING A DIAGNOSTIC TRANSMISSION MODE AND COMMUNICATING OVER THE SAME
<b>First Named Inventor/Applicant Name:</b>	David M. Krinsky
<b>Customer Number:</b>	62574
<b>Filer:</b>	Jason Vick/Joanne Vos
<b>Filer Authorized By:</b>	Jason Vick
<b>Attorney Docket Number:</b>	5550-2-CON-2-1
<b>Receipt Date:</b>	13-MAY-2010
<b>Filing Date:</b>	03-JUN-2009
<b>Time Stamp:</b>	16:30:26
<b>Application Type:</b>	Utility under 35 USC 111(a)

### Payment information:

Submitted with Payment	yes
Payment Type	Deposit Account
Payment was successfully received in RAM	\$660
RAM confirmation Number	2863
Deposit Account	191970
Authorized User	

The Director of the USPTO is hereby authorized to charge indicated fees and credit any overpayment as follows:

Charge any Additional Fees required under 37 C.F.R. Section 1.16 (National application filing, search, and examination fees)

Charge any Additional Fees required under 37 C.F.R. Section 1.17 (Patent application and reexamination processing fees)

Charge any Additional Fees required under 37 C.F.R. Section 1.19 (Document supply fees)  
 Charge any Additional Fees required under 37 C.F.R. Section 1.20 (Post Issuance fees)  
 Charge any Additional Fees required under 37 C.F.R. Section 1.21 (Miscellaneous fees and charges)

**File Listing:**

Document Number	Document Description	File Name	File Size(Bytes)/ Message Digest	Multi Part /.zip	Pages (if appl.)
1		AMEND_PRELIM_02.pdf	342711 fb732af23013f1d80fed77924d4abafcb71b3ab	yes	5

Multipart Description/PDF files in .zip description				
	Document Description	Start	End	
	Preliminary Amendment	1	1	
	Specification	2	2	
	Claims	3	4	
	Applicant Arguments/Remarks Made in an Amendment	5	5	

**Warnings:**

**Information:**

2	Fee Worksheet (PTO-875)	fee-info.pdf	30538 abc4862ca6589c1126f98aa19b4fa308a8eb3438	no	2
---	-------------------------	--------------	---	----	---

**Warnings:**

**Information:**

<b>Total Files Size (in bytes):</b>	373249
-------------------------------------	--------

This Acknowledgement Receipt evidences receipt on the noted date by the USPTO of the indicated documents, characterized by the applicant, and including page counts, where applicable. It serves as evidence of receipt similar to a Post Card, as described in MPEP 503.

**New Applications Under 35 U.S.C. 111**

If a new application is being filed and the application includes the necessary components for a filing date (see 37 CFR 1.53(b)-(d) and MPEP 506), a Filing Receipt (37 CFR 1.54) will be issued in due course and the date shown on this Acknowledgement Receipt will establish the filing date of the application.

**National Stage of an International Application under 35 U.S.C. 371**

If a timely submission to enter the national stage of an international application is compliant with the conditions of 35 U.S.C. 371 and other applicable requirements a Form PCT/DO/EO/903 indicating acceptance of the application as a national stage submission under 35 U.S.C. 371 will be issued in addition to the Filing Receipt, in due course.

**New International Application Filed with the USPTO as a Receiving Office**

If a new international application is being filed and the international application includes the necessary components for an international filing date (see PCT Article 11 and MPEP 1810), a Notification of the International Application Number and of the International Filing Date (Form PCT/RO/105) will be issued in due course, subject to prescriptions concerning national security, and the date shown on this Acknowledgement Receipt will establish the international filing date of the application.

Under the Paperwork Reduction Act of 1995, no persons are required to respond to a collection of information unless it displays a valid OMB control number.

<b>PATENT APPLICATION FEE DETERMINATION RECORD</b> Substitute for Form PTO-875					Application or Docket Number <b>12/477,742</b>	Filing Date <b>06/03/2009</b>	<input type="checkbox"/> To be Mailed						
<b>APPLICATION AS FILED – PART I</b>					<b>OTHER THAN</b>								
(Column 1)		(Column 2)		SMALL ENTITY <input type="checkbox"/>		OR		SMALL ENTITY					
FOR	NUMBER FILED	NUMBER EXTRA	RATE (\$)	FEE (\$)	OR	RATE (\$)	FEE (\$)						
<input type="checkbox"/> BASIC FEE <small>(37 CFR 1.16(a), (b), or (c))</small>	N/A	N/A	N/A			N/A							
<input type="checkbox"/> SEARCH FEE <small>(37 CFR 1.16(k), (j), or (m))</small>	N/A	N/A	N/A			N/A							
<input type="checkbox"/> EXAMINATION FEE <small>(37 CFR 1.16(o), (p), or (q))</small>	N/A	N/A	N/A			N/A							
TOTAL CLAIMS <small>(37 CFR 1.16(i))</small>	minus 20 =	*	X \$ =			X \$ =							
INDEPENDENT CLAIMS <small>(37 CFR 1.16(h))</small>	minus 3 =	*	X \$ =			X \$ =							
<input type="checkbox"/> APPLICATION SIZE FEE <small>(37 CFR 1.16(s))</small>	If the specification and drawings exceed 100 sheets of paper, the application size fee due is \$250 (\$125 for small entity) for each additional 50 sheets or fraction thereof. See 35 U.S.C. 41(a)(1)(G) and 37 CFR 1.16(s).												
<input type="checkbox"/> MULTIPLE DEPENDENT CLAIM PRESENT <small>(37 CFR 1.16(j))</small>													
* If the difference in column 1 is less than zero, enter "0" in column 2.			TOTAL			TOTAL							
<b>APPLICATION AS AMENDED – PART II</b>						<b>OTHER THAN</b>							
(Column 1)		(Column 2)		(Column 3)		SMALL ENTITY		OR		SMALL ENTITY			
<b>AMENDMENT</b>	<b>05/13/2010</b>	CLAIMS REMAINING AFTER AMENDMENT	HIGHEST NUMBER PREVIOUSLY PAID FOR	PRESENT EXTRA	RATE (\$)	ADDITIONAL FEE (\$)	OR	RATE (\$)	ADDITIONAL FEE (\$)				
	Total <small>(37 CFR 1.16(i))</small>	* 6	Minus	** 20	= 0	X \$ =		OR	X \$52=	0			
	Independent <small>(37 CFR 1.16(h))</small>	* 6	Minus	***3	= 3	X \$ =		OR	X \$220=	660			
	<input type="checkbox"/> Application Size Fee <small>(37 CFR 1.16(s))</small>								OR				
	<input type="checkbox"/> FIRST PRESENTATION OF MULTIPLE DEPENDENT CLAIM <small>(37 CFR 1.16(j))</small>								OR				
					TOTAL ADD'L FEE		OR	TOTAL ADD'L FEE	<b>660</b>				
(Column 1)		(Column 2)		(Column 3)		SMALL ENTITY		OR		SMALL ENTITY			
<b>AMENDMENT</b>	CLAIMS REMAINING AFTER AMENDMENT	HIGHEST NUMBER PREVIOUSLY PAID FOR	PRESENT EXTRA	RATE (\$)	ADDITIONAL FEE (\$)	OR	RATE (\$)	ADDITIONAL FEE (\$)					
	Total <small>(37 CFR 1.16(i))</small>	*	Minus	**	=		X \$ =	OR	X \$ =				
	Independent <small>(37 CFR 1.16(h))</small>	*	Minus	***	=		X \$ =	OR	X \$ =				
	<input type="checkbox"/> Application Size Fee <small>(37 CFR 1.16(s))</small>								OR				
	<input type="checkbox"/> FIRST PRESENTATION OF MULTIPLE DEPENDENT CLAIM <small>(37 CFR 1.16(j))</small>								OR				
					TOTAL ADD'L FEE		OR	TOTAL ADD'L FEE					
* If the entry in column 1 is less than the entry in column 2, write "0" in column 3.					Legal Instrument Examiner: /Renee Collins/								
** If the "Highest Number Previously Paid For" IN THIS SPACE is less than 20, enter "20".													
*** If the "Highest Number Previously Paid For" IN THIS SPACE is less than 3, enter "3".													
The "Highest Number Previously Paid For" (Total or Independent) is the highest number found in the appropriate box in column 1.													

This collection of information is required by 37 CFR 1.16. The information is required to obtain or retain a benefit by the public which is to file (and by the USPTO to process) an application. Confidentiality is governed by 35 U.S.C. 122 and 37 CFR 1.14. This collection is estimated to take 12 minutes to complete, including gathering, preparing, and submitting the completed application form to the USPTO. Time will vary depending upon the individual case. Any comments on the amount of time you require to complete this form and/or suggestions for reducing this burden, should be sent to the Chief Information Officer, U.S. Patent and Trademark Office, U.S. Department of Commerce, P.O. Box 1450, Alexandria, VA 22313-1450. DO NOT SEND FEES OR COMPLETED FORMS TO THIS ADDRESS. **SEND TO: Commissioner for Patents, P.O. Box 1450, Alexandria, VA 22313-1450.**  
 If you need assistance in completing the form, call 1-800-PTO-9199 and select option 2.

Under the Paperwork Reduction Act of 1995, no persons are required to respond to a collection of information unless it displays a valid OMB control number.

<b>PATENT APPLICATION FEE DETERMINATION RECORD</b> Substitute for Form PTO-875					Application or Docket Number <b>12/477,742</b>	Filing Date <b>06/03/2009</b>	<input type="checkbox"/> To be Mailed						
<b>APPLICATION AS FILED – PART I</b>					<b>OTHER THAN</b>								
(Column 1)		(Column 2)		SMALL ENTITY <input type="checkbox"/>		OR		SMALL ENTITY					
FOR	NUMBER FILED	NUMBER EXTRA	RATE (\$)	FEE (\$)	OR	RATE (\$)	FEE (\$)						
<input type="checkbox"/> BASIC FEE <small>(37 CFR 1.16(a), (b), or (c))</small>	N/A	N/A	N/A			N/A							
<input type="checkbox"/> SEARCH FEE <small>(37 CFR 1.16(k), (j), or (m))</small>	N/A	N/A	N/A			N/A							
<input type="checkbox"/> EXAMINATION FEE <small>(37 CFR 1.16(o), (p), or (q))</small>	N/A	N/A	N/A			N/A							
TOTAL CLAIMS <small>(37 CFR 1.16(i))</small>	minus 20 =	*	X \$ =			X \$ =							
INDEPENDENT CLAIMS <small>(37 CFR 1.16(h))</small>	minus 3 =	*	X \$ =			X \$ =							
<input type="checkbox"/> APPLICATION SIZE FEE <small>(37 CFR 1.16(s))</small>	If the specification and drawings exceed 100 sheets of paper, the application size fee due is \$250 (\$125 for small entity) for each additional 50 sheets or fraction thereof. See 35 U.S.C. 41(a)(1)(G) and 37 CFR 1.16(s).												
<input type="checkbox"/> MULTIPLE DEPENDENT CLAIM PRESENT <small>(37 CFR 1.16(j))</small>													
* If the difference in column 1 is less than zero, enter "0" in column 2.			TOTAL				TOTAL						
<b>APPLICATION AS AMENDED – PART II</b>						<b>OTHER THAN</b>							
(Column 1)		(Column 2)		(Column 3)		SMALL ENTITY		OR		SMALL ENTITY			
<b>AMENDMENT</b>	<b>05/13/2010</b>	CLAIMS REMAINING AFTER AMENDMENT	HIGHEST NUMBER PREVIOUSLY PAID FOR	PRESENT EXTRA	RATE (\$)	ADDITIONAL FEE (\$)	OR	RATE (\$)	ADDITIONAL FEE (\$)				
	Total <small>(37 CFR 1.16(i))</small>	* 6	Minus	** 20	= 0	X \$ =			X \$52=	0			
	Independent <small>(37 CFR 1.16(h))</small>	* 6	Minus	***3	= 3	X \$ =			X \$220=	660			
	<input type="checkbox"/> Application Size Fee <small>(37 CFR 1.16(s))</small>												
	<input type="checkbox"/> FIRST PRESENTATION OF MULTIPLE DEPENDENT CLAIM <small>(37 CFR 1.16(j))</small>												
					TOTAL ADD'L FEE			TOTAL ADD'L FEE	<b>660</b>				
(Column 1)		(Column 2)		(Column 3)		SMALL ENTITY		OR		SMALL ENTITY			
<b>AMENDMENT</b>	CLAIMS REMAINING AFTER AMENDMENT	HIGHEST NUMBER PREVIOUSLY PAID FOR	PRESENT EXTRA	RATE (\$)	ADDITIONAL FEE (\$)	OR	RATE (\$)	ADDITIONAL FEE (\$)					
	Total <small>(37 CFR 1.16(i))</small>	*	Minus	**	=		X \$ =		X \$ =				
	Independent <small>(37 CFR 1.16(h))</small>	*	Minus	***	=		X \$ =		X \$ =				
	<input type="checkbox"/> Application Size Fee <small>(37 CFR 1.16(s))</small>												
	<input type="checkbox"/> FIRST PRESENTATION OF MULTIPLE DEPENDENT CLAIM <small>(37 CFR 1.16(j))</small>												
					TOTAL ADD'L FEE			TOTAL ADD'L FEE					

\* If the entry in column 1 is less than the entry in column 2, write "0" in column 3.  
 \*\* If the "Highest Number Previously Paid For" IN THIS SPACE is less than 20, enter "20".  
 \*\*\* If the "Highest Number Previously Paid For" IN THIS SPACE is less than 3, enter "3".

The "Highest Number Previously Paid For" (Total or Independent) is the highest number found in the appropriate box in column 1.

Legal Instrument Examiner:  
 /Renee Collins/

This collection of information is required by 37 CFR 1.16. The information is required to obtain or retain a benefit by the public which is to file (and by the USPTO to process) an application. Confidentiality is governed by 35 U.S.C. 122 and 37 CFR 1.14. This collection is estimated to take 12 minutes to complete, including gathering, preparing, and submitting the completed application form to the USPTO. Time will vary depending upon the individual case. Any comments on the amount of time you require to complete this form and/or suggestions for reducing this burden, should be sent to the Chief Information Officer, U.S. Patent and Trademark Office, U.S. Department of Commerce, P.O. Box 1450, Alexandria, VA 22313-1450. DO NOT SEND FEES OR COMPLETED FORMS TO THIS ADDRESS. **SEND TO: Commissioner for Patents, P.O. Box 1450, Alexandria, VA 22313-1450.**

If you need assistance in completing the form, call 1-800-PTO-9199 and select option 2.



Substitute for form 1449A/PTO				<b>Complete if Known</b>	
<b>INFORMATION DISCLOSURE STATEMENT BY APPLICANT</b>				Application Number	12/477,742
				Filing Date	June 3, 2009
				First Named Inventor	David M. Krinsky
				Art Unit	2611
				Examiner Name	Not yet assigned
Sheet	1	of	4	Attorney Docket Number	5550-2-CON-2-1

U.S. PATENT DOCUMENTS					
Examiner Initials*	Cite No. <sup>1</sup>	Document Number Number-kind Code <sup>2</sup> (if known)	Publication Date MM-DD-YYYY	Name of Patentee of Applicant of Cited Document	Pages, Columns, Lines, Where Relevant Passages or Relevant Figures Appear
	1	4385384	05/24/83	Rosbury et al.	
	2	4566100	01/21/86	Mizuno et al.	
	3	5128619	07/07/92	Bjork et al.	
	4	5361293	11/01/94	Czerwiec	
	5	5608643	03/04/97	Wichter et al.	
	6	5864602	01/26/99	Needle	
	7	5964891	10/12/99	Caswell et al.	
	8	6073179	06/06/00	Liu et al.	
	9	6075821	06/13/00	Kao et al.	
	10	6175934	01/16/01	Hershey et al.	
	11	6219378	04/17/01	Wu	
	12	6404774	06/11/02	Jenness	
	13	6411678	06/25/02	Tomlinson, Jr. et al.	
	14	6449307	09/10/02	Ishikawa et al.	
	15	6512789	01/28/03	Mirfakhraei	
	16	6631120	10/07/03	Milbrandt	
	17	6633545	10/14/03	Milbrandt	
	18	6636603	10/21/03	Milbrandt	
	19	6725176	04/20/04	Long et al.	
	20	6658052	12/02/03	Krinsky et al.	
	21	7570686	08/04/09	Krinsky et al.	

FOREIGN PATENT DOCUMENTS						
Examiner Initials*	Cite No. <sup>1</sup>	Foreign Patent Document Country Code <sup>3</sup> ; Number <sup>4</sup> ; Kind Code <sup>5</sup> (if known)	Publication Date MM-DD-YYYY	Name of Patentee or Applicant of Cited Document	Pages, Columns, Lines, Where Relevant Passages or Relevant Figures Appear	T <sup>6</sup>
	22	EP 0889615	01/07/99	INTEGRATED TELECOM EXPRESS		

Examiner Signature		Date Considered	
--------------------	--	-----------------	--

\*EXAMINER: Initial if reference is considered, whether or not citation is in conformance and not considered. Include copy of this form with next communication to applicant.

Substitute for form 1449A/PTO				<b>Complete if Known</b>	
<b>INFORMATION DISCLOSURE STATEMENT BY APPLICANT</b>				Application Number	12/477,742
				Filing Date	June 3, 2009
				First Named Inventor	David M. Krinsky
				Art Unit	2611
				Examiner Name	Not yet assigned
Sheet	2	of	4	Attorney Docket Number	5550-2-CON-2-1

	23	GB 2303032	02/05/97	SAMSUNG ELECTRONICS CO LTD		
	24	JP Hei6(1994)-003956	01/12/94	TELEBIT CORPORATION		(believed to correspond to WO 86/07223 disclosed herein)
	25	JP-A-Hei10(1998)-513622	12/22/98	ADC TELECOMMUNICATIO NS INC		(Translated abstract)
	26	JP-A-Hei11(1999)-261665	09/24/99	MATSUSHITA GRAPHIC COMMUNIC		(Translated abstract)
	27	JP-A-Hei11(1999)-317723	11/16/99	MOTOROLA INC		(Translated abstract)
	28	JP-A-Hei11(1999)-508417	07/21/99	ERICSSON TELEFON AB L M		(Translated abstract)
	29	WO 00/64130	10/26/00	TERADYNE INC		
	30	WO 86/07223	12/04/86	TELEBIT CORPORATION		(believed to correspond to JP Hei6(1994)- 003956 disclosed herein)
	31	WO 97/01900	01/16/97	ERICSSON AUSTRIA AG		
	32	WO 99/020027	04/22/99	Aware		
	33	WO 99/26375	05/27/99	TEKTRONIX INC		
	34	WO 99/63427	12/09/99	GTE LABORATORIES INC		

Examiner Signature		Date Considered	
-----------------------	--	--------------------	--

\*EXAMINER: Initial if reference is considered, whether or not citation is in conformance and not considered. Include copy of this form with next communication to applicant.

Substitute for form 1449A/PTO				<b>Complete if Known</b>	
<b>INFORMATION DISCLOSURE STATEMENT BY APPLICANT</b>				Application Number	12/477,742
				Filing Date	June 3, 2009
				First Named Inventor	David M. Krinsky
				Art Unit	2611
				Examiner Name	Not yet assigned
Sheet	3	of	4	Attorney Docket Number	5550-2-CON-2-1

OTHER ART (Including Author, Title, Date, Pertinent Pages, etc.)		
Examiner Initials*	Cite No. <sup>1</sup>	
	35	Boets P. et al.: "Modeling Aspect of Transmission Line Networks" Proceedings Of The Instrumentation And Measurement Technology Conference, US, New York, IEEE, May 12, 1992, pp. 137-141, XP000343913 ISBN: 0-7803-0640-6
	36	Cioffi, John M., ADSL Maintenance with DMT, T1E1.4 ADSL Project, Amati Communications Corporation, December 1, 1992, pages 1-14
	37	Lewis L. et al. "Extending Trouble Ticket System to Fault Diagnostics" IEEE Network, IEEE Inc. New York, US, Nov. 1, 1993, pp. 44-51, XP 000575228
	38	International Search Report for PCT/US01/00418 dated Jul. 16, 2001; 4 pages (5550-2-PCT)
	39	Written Opinion for International (PCT) Patent Application No. PCT/US01/00418, completed March 9, 2002 (5550-2-PCT)
	40	International Preliminary Examination Report for International (PCT) Patent Application No. PCT/US01/00418, completed March 9, 2002 (5550-2-PCT)
	41	PCT International Search Report dated Oct. 9, 2002 for PCT/US01/41653 (5550-2-PCT-3)
	42	Examiner's First Report for Australian Patent Application No. 27669/01, mailed April 2, 2004 (Attorney's Ref. No. 5550-2-PAU)
	43	Notice of Acceptance for Australian Patent Application No. 27669/01, mailed August 6, 2004 (Attorney's Ref. No. 5550-2-PAU)
	44	Examiner's First Report for Australian Patent Application No. 2004203321, mailed November 16, 2006 (5550-2-PAU4)
	45	Examiner's First Report for Australian Patent Application No. 2008203520, mailed March 9, 2009 (5550-2-PAU4-DIV)
	46	Notice of Acceptance for Australian Patent Application No. 2008203520, mailed July 9, 2009 (5550-2-PAU4-DIV)
	47	Official Action for Canadian Patent Application No. 2,394,491, mailed November 24, 2009 (Attorney's Ref. No. 5550-2-PCA)
	48	Official Action for European Patent Application No. 01901808.4, mailed December 1, 2004 (Attorney's Ref. No. 5550-2-PEP)

Examiner Signature		Date Considered	
-----------------------	--	--------------------	--

\*EXAMINER: Initial if reference is considered, whether or not citation is in conformance and not considered. Include copy of this form with next communication to applicant.

Substitute for form 1449A/PTO			<b>Complete if Known</b>		
<b>INFORMATION DISCLOSURE STATEMENT BY APPLICANT</b>			Application Number	12/477,742	
			Filing Date	June 3, 2009	
			First Named Inventor	David M. Krinsky	
			Art Unit	2611	
			Examiner Name	Not yet assigned	
Sheet	4	of	4	Attorney Docket Number	5550-2-CON-2-1

	49	Official Action for European Patent Application No. 01901808.4, mailed September 14, 2005 (Attorney's Ref. No. 5550-2-PEP)
	50	Communication about intention to grant a European patent for European Patent Application No. 01901808.4, mailed May 15, 2006 (Attorney's Ref. No. 5550-2-PEP)
	51	European Search Report for European Patent Application No. EP 06022008 completed January 8, 2007 (5550-2-PEP5)
	52	Notification of Reasons (including translation) for Refusal for Japanese Patent Application No. 2001-552611, Dispatched Date: December 7, 2009 (Attorney's Ref. No. 5550-2-PJP)
	53	Decision to Grant Patent (including translation) For Korean Patent Application No. 10-2002-7008794, dated December 1, 2006 (Attorney's Ref. No. 5550-2-PKR)

Examiner Signature		Date Considered	
-----------------------	--	--------------------	--

\*EXAMINER: Initial if reference is considered, whether or not citation is in conformance and not considered. Include copy of this form with next communication to applicant.

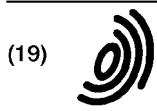

Europäisches Patentamt  
 European Patent Office  
 Office européen des brevets



(11) EP 0 889 615 A2

(12) EUROPEAN PATENT APPLICATION

(43) Date of publication:  
 07.01.1999 Bulletin 1999/01

(51) Int. Cl.<sup>6</sup>: H04L 5/14, H04L 27/26

(21) Application number: 98112040.5

(22) Date of filing: 30.06.1998

(84) Designated Contracting States:  
 AT BE CH CY DE DK ES FI FR GB GR IE IT LI LU  
 MC NL PT SE  
 Designated Extension States:  
 AL LT LV MK RO SI

(72) Inventors:  
 • Liu, Young Way  
 La Mirada, California 90638 (US)  
 • Liu, Ming-Kang  
 Cupertino, California 95014 (US)  
 • Chen, Steve  
 San Jose, California 95132 (US)

(30) Priority: 30.06.1997 US 884895

(71) Applicant:  
 Integrated Telecom Express  
 Santa Clara, California 95051 (US)

(74) Representative:  
 Lins, Edgar, Dipl.-Phys. Dr.jur.  
 Gramm, Lins & Partner GbR,  
 Theodor-Heuss-Strasse 1  
 38122 Braunschweig (DE)

(54) Multicarrier transmission with variable data rate

(57) A high speed communications system is provided which uses a selectable, desirable portion of the total available bandwidth of a transmission channel. In a preferred embodiment, the invention is an ADSL compatible modem which selects a sub-set of the available downstream DMT sub-channels based on an evaluation of such sub-channels by appropriate signal processing circuitry. An analog front end (AFE) contains sub-band filtering causes an upstream transceiver to use only this selected number of available sub-channels for down-

stream data transmission. This reduces hardware costs and complexity while still preserving compatibility with applicable ADSL standards and providing a high speed data link. The target data rate of the modem can be further enhanced to the point of achieving full protocol capability by increasing or upgrading the AFEs, and/or the signal processing circuitry in order to increase the number of processable transmitted downstream sub-channels.

FIGURE 6

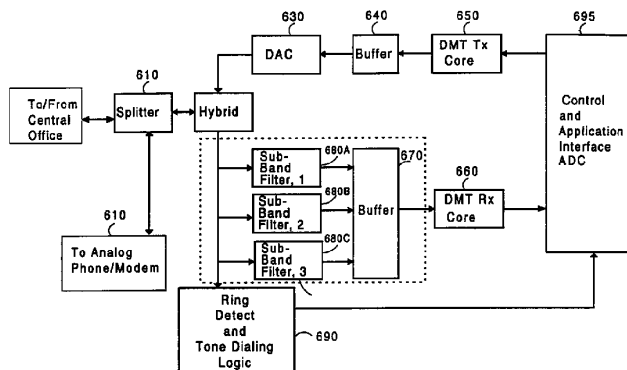

EP 0 889 615 A2

**Description**FIELD OF THE INVENTION

5 The invention relates generally to an improved high-speed communications system which establishes a data link using only a selectable portion of the total available bandwidth of a channel. The present invention has particular applicability to systems which use rate adaptable techniques such as the discrete multi-tone modulation (DMT) technique and CAP for transmitting data in Digital Subscriber Lines and similar environments. By limiting the data throughput of the link to some adjustable fraction of the total available data rate, the present invention significantly reduces hardware costs and allows a downstream user to configure a data link whose performance is directly controllable by the processing power available to such user. In this manner, the system is completely forward compatible and expandable in functionality, and permits a user to increase throughput to the point of achieving full potential of the available channel bandwidth .

15 BACKGROUND OF THE INVENTION

Remote access and retrieval of data and information are becoming more desirable and common in both consumer and business environments. As data and information transfer is becoming more and more voluminous and complex, using traditional data links such as voice-band modems is too slow in speed. For example, the use of the Internet to locate and access information is increasing daily, but the retrieval of typical graphics, video, audio, and other complex data forms is generally unsatisfyingly slow using conventional voice-band modems. In fact, the slow rate of existing dial-up analog modems frustrates users, and commerce and interaction using the Internet would have been even higher were it not for the unacceptable delays associated with present day access technology. The ability to provide such desired services as video on demand, television (including HDTV, video catalogs, remote CD-ROMs, high-speed LAN access, electronic library viewing, etc., are similarly impeded by the lack of high speed connections.

Since the alternatives to copper line technology have proven unsatisfactory, solutions to the high speed access problem have been focused on improving the performance of voice band modems. Voice band modems operate at the subscriber premises end over a 3 kHz voice band lines and transmit signals through the core switching network, the phone company network treats them exactly like voice signals. These modems presently transmit up to 33.6 kbps over a 2-wire telephone line, even though the practical speed only twenty years ago was 1.2 kbps. The improvement in voice band modems over the past 20 years has resulted from significant advances in algorithms, digital signal processing, and semiconductor technology. Because such modems are limited to voice bandwidth (3.0 kHz), the rate is bound by the Shannon limit, around 30 kbps. A V.34 modem, for example, achieves 10 bits per Hertz of bandwidth, a figure that approaches the theoretical Shannon limits.

35 There is a considerable amount of bandwidth available in copper lines, however, that has gone unused by voice band modems, and this is why a proposal known as Asymmetric Digital Subscriber Line (ADSL) was suggested in the industry as a high-speed protocol/connection alternative. The practical limits on data rate in conventional telephone line lengths (of 24 gauge twisted pair) vary from 1.544 Mbps for an 18,000 foot connection, to 51.840 Mbps for a 1,000 foot connection. Since a large proportion of current telephone subscribers fall within the 18,000 foot coverage range, ADSL can make the current copper wire act like a much "bigger pipe" for sending computer bits and digital information (like movies and TV channels), while still carrying the voice traffic. For example, an ADSL modem can carry information 200 times faster than the typical voice band modem used today.

ADSL is "asymmetric" in that more data goes downstream (to the subscriber) than upstream (back from the subscriber). The reason for this is a combination of cost, demand, and performance. For example, twisted pair wiring coupling increases with the frequency of the signal. If symmetric signals in many pairs are used within a cable, the data rate and line length become significantly limited by the coupling noise. Since the preponderance of target applications for digital subscriber services is asymmetric, asymmetric bit rate is not perceived to be a serious limitation at this time. Therefore, the ADSL standard proposes up to 6 Mbps for downstream, and up to 640 kbps for upstream. For example, video on demand, home shopping, Internet access, remote LAN access, multimedia access, and specialized PC services all feature high data rate demands downstream, to the subscriber, but relatively low data rates demands upstream. The principal advantage is that all of the high speed data operations take place in a frequency band above the voice band, leaving Plain Old Telephone Service (POTS) service independent and undisturbed, even if an ADSL modem fails. ADSL further provides an economical solution for transmission of high bandwidth information over existing copper line infrastructures.

55 Specifically, the proposed standard for ADSL divides the available transmission bandwidth into two parts. At the lower 4 kHz band, ordinary (POTS) is provided. The bulk of the rest bandwidth in the range from 4 kHz to about 1 MHz is for data transmission in the downstream direction, which is defined to be from the exchange to the subscriber. The upstream control channel uses a 160 kHz band in between. The signals in each channel can be extracted with an

appropriate band -pass filter.

A DMT implementation of ADSL uses the entire available 1 MHz range of a copper phone line. It merely splits the signal into 255 separate channels, and each 4 kHz channel can be made to provide a bit rate up to the best present day voice band (33.6 kbs) modems. This results essentially in overall performance which is equivalent to around two hundred V.34 modems used in parallel on the same line. Because each channel can be configured to a different bit rate according to the channel characteristics, it can be seen that DMT is inherently "rate-adaptive" and extremely flexible for interfacing with different subscriber equipment and line conditions.

A number of problems arise, however, in attempting to implement a full scale ADSL transceiver cost-effectively.

First, to achieve this high bit rate transmission over existing telephone subscriber loops, advanced analog front end (AFE) devices, complicated digital signal processing techniques, and high speed complex digital designs are required. As a result, this pushes current technology limits and imposes both high cost and power consumption. For example, AFE devices in modem applications provide the interface between analog wave forms and digital samples for digital hardware/software processing. In high speed modern technologies such as ADSL, AFE devices need to operate at a very high sampling rate and high accuracy. For example, the DMT technology has a spectrum of 1 MHz and requires sampling above 50 MHz if a sigma-delta analog-to-digital (ADC) method is used. This thus requires the state-of-art ADC technology and imposes a high cost for end users.

Second, the time domain signal in ADSL/DMT transmissions is a summation of a large number of carriers modulated by quadrature amplitude modulation (QAM). This typically results in a large peak-to-peak deviation. As a result, even though a high speed AFE is made possible, a large dynamic range and high resolution AFE is required at the same time to minimize quantization errors.

Third, in addition to the high sampling rate and resolution requirement for ADSL AFEs, the other hardware and software in ADSL environment also needs to operate at a much higher speed than current conventional modem counterparts. For example, to implement the DMT technology in software, a custom and dedicated digital signal process (DSP) of a power of several hundred MIPS (millions instructions per second) is required to process many components such as error encoding and decoding, spectrum transforms, timing synchronization, etc. As with the AFE part of the system, this high speed requirement for the signal processing portion of ADSL also results in less flexible, high component costs.

Fourth, requiring a communications device (such as a modem) to fully support the total throughput of a standard such as ADSL may be inefficient in some cases, since many prospective users of high-speed data links may not need to use all the available bandwidth provided by such standards. It is generally more preferable therefore to permit users to throttle or scale the data throughput in a manner they can control, based on their particular application needs, hardware cost budget, etc. For example, a full-scale ADSL system may have the performance level of 200 times conventional V.34 modems, but it is apparent that even a performance improvement of 10 - 20 times than present day available analog modems would be sufficient for many consumer applications, such as Internet access and similar uses. Thus, unlike conventional analog modems, which are available in various speeds varying generally from 14.4 to 56 Kbps, there are no known ADSL modems which offer scalable performance levels to users.

Fifth, in addition to the implementation challenge, the T1E1.4 ADSL standard does not specify the system interface and user model. Although various high level interface to support T1 /E1, ATM, etc. have been described, system integration with high level protocols such as TCP/IP and interface with computer operating systems have not yet been defined. As a result, there is uncertainty how existing and future modem-based applications can work with the ADSL technology. For example, when users run an Internet application which sends and receives data to and from an Internet service provider (ISP), a mutually agreed protocol is required to set up a call and transfer data. Possible protocols available at various levels include ATM (asynchronous transfer mode), TCP/IP, ISDN, and current modem AT commands. Either one of these or a possibly new protocol needs to be defined to facilitate the adoption of ADSL technology.

SUMMARY OF THE INVENTION

An object of the present invention therefore is to provide a communications system which is fully compatible with high speed, rate adaptable protocols such as are used with ADSL, but which system is nevertheless implementable with simpler analog front end receiving/transmitting circuitry and is thus reduced in cost and complexity;

A further object of the present invention is to provide a communications system which is fully compatible with high speed, rate adaptable modulation protocols such as used with ADSL, but which system is nevertheless implementable with simpler digital signal processing circuitry and is thus reduced in cost and complexity;

Another objective of the present invention is to provide a method for transmitting data within a fractional, desirable portion of available bandwidth in a channel by modulating only a limited number of desirable sub-channel data carriers, so that a high speed data link can be achieved that is faster, and has reduced computation and hardware demands;

Yet a further objective of the present invention is to provide a communications system with smaller peak-to-peak deviation in the sub-channels signals, so as to reduce the dynamic range required for the front end ADC, and to mini-

mize quantization errors.

Another objective of the present invention is to provide a high speed communications system having a data throughput that is easily controllable and expandable, so that the performance range of such system can be configured to any fractional percentage of total bandwidth available in a transmission channel, up to and including full bandwidth use of the channel;

A related objective of the present invention is to provide a high speed communications system that is modular so that forward compatible and expandable functionality can be incorporated flexibly and with a minimum of effort on the part of a user of such system;

Yet a further objective is to provide a system that is compatible with high speed protocols used in ADSL, but which is also easily adaptable to support preexisting high level data protocols, including those presently used for controlling high speed voice band modems;

A further object of the present invention is to provide a high speed communications system that self-calibrates its own performance level, based on the processing power available to such system;

Another objective of the present invention is to provide a high speed communications system that permits a user to configure the performance parameters of such system using conventional personal computer hardware, software and operating systems;

A further object of the present invention is to provide an interface between a host operating system and a high speed communications system that provide forward compatible and expandable functionality;

An additional aim of the present invention is to provide an improved system for concurrent control of conventional voice data traffic on a POTS channel, and upstream/downstream communications on separate sub-channels;

These objects and others are accomplished by providing a communications system that permits a host processing device to receive selected data within a narrow bandwidth from an upstream transceiver which can and normally transmits a large bandwidth analog data transmission signal through a connected channel. A channel interface circuit AFE samples the received analog signal to generate a digital signal. Only a limited portion of the bandwidth may be sampled, thus reducing front end complexity. A digital signal processing circuit then extracts the selected data from this limited digital signal, which is significantly easier to process than a full bandwidth digital signal. Feedback information is provided back to the upstream transmitter which causes the upstream transmitter to transmit downstream data thereafter only using the limited bandwidth of the front end, and not the full bandwidth. This feedback information contains information about the channel that suggests to the upstream transmitter that the other bandwidth in the channel is unusable. In this manner, the upstream transceiver is trained to accommodate the lower rate downstream transceiver in a manner that nevertheless preserves protocol integrity.

In a preferred embodiment, the large bandwidth analog data transmission signal is comprised of a number of DMT modulated sub-channels, and an anti-aliasing filter on the front end of the the downstream transceiver ensures that only a limited number of such sub-channels are processed by a DMT signal processing core. The feedback information consists of non-zero SNR information for the selected sub-channels, and a sub-channel blackout "mask" to eliminate the potential use of other sub-channels. The feedback information is sent by way of a front end transmitting circuit which transmits an upstream data transmission using a second frequency range different from the downstream transmission.

One implementation of the aforementioned high speed system is in a personal computer, so that the signal processing can be accomplished using a processor within such computer, which in a preferred embodiment is an X86 compatible processor. Another implementation of the aforementioned high speed system uses a dedicated signal processor for demodulating the selected sub-channels. This cuts down on processing overhead requirements for a host processing system incorporating the system. In such implementations the portion of the downstream data transmission to be processed for data extraction can be configured by a user of such systems, or alternatively, it can be dynamically determined based on an evaluation by the digital signal processing circuit of performance characteristics of different portions of the frequency spectrum within the bandwidth potential of the upstream transceiver.

In another variation, the data rate of a system such as described above can be increased by processing data from an additional second limited frequency bandwidth portion of the total available downstream bandwidth. In a preferred embodiment, this can be done by including a number of anti-aliasing filters in a modular bank as part of the analog front end section, each of which passes a different frequency bandwidth portion. By making the analog front end modular, the data rate of the overall system can be scaled in a controllable and cost-effective fashion. At the same time, each analog front end portion can be operated at a slower sampling clock and smaller dynamic range. This results in a more relaxed speed requirement and smaller quantization noise at a given number of bits per sample.

The present disclosure also includes an interface to an operating system, to facilitate controlling the high speed communications system when it is incorporated in a personal computer system. This interface ensures that the operating system treats such communications system essentially the same as other prior art voice band modems, and in a preferred embodiment, is a device driver for the Windows NT operating shell. Finally, the present disclosure also describes an applications program which permits a user of a personal computer to control the performance characteristics of the high speed communications system by setting certain system parameters when such system is incorpo-



rated in a personal computer system. This program includes an auto calibration routine for setting such system parameters, or alternatively a user of such program can tailor the settings subject to confirmation of the efficacy of such settings based on an evaluation of the processing power available to such user.

5 Although the inventions are described below in a preferred embodiment implementing the ADSL standard, it will be apparent to those skilled in the art the present invention would be beneficially used in any high speed rate-adaptable applications.

10 It should be noted that while some prior art devices also have limited mechanisms for achieving a reduction of nominal or peak transmission speed in a channel, they only activate or implement such mechanisms as a fallback response to a failure in the channel, or because of a transmission rate reduction in the upstream transceiver. Unlike the present invention, such prior art modems, during an initialization process, attempt to establish the highest possible transmission rate achievable by the channel and the upstream transceiver. In other words, any rate reduction imposed by the downstream modem is typically considered an unintended and undesirable side effect of bad channel characteristics, and not a desirable and intentional design target as set forth in the present invention. In addition, the data rate reduction in such modems is accomplished primarily by varying the number of bits per baud (hertz) at a fixed frequency, and not by controlling the overall frequency spectrum of the downstream data transmission. Moreover, in such prior art systems, no effort is made to measure, identify or use an optimal portion of the usable bandwidth or set of transmission sub-channels. Instead, such prior art systems typically use whatever available bandwidth or sub-channels happen to be usable at that instant in time.

15 Similarly, while a fixed 300 baud rate downstream modem can work with an upstream 33kbs rate modem this arrangement is also unlike the present invention. This is because, again, the bandwidth reduction in such prior art device is so large that it is considered commercially unusable by today's standards. Furthermore, the smaller bandwidth modem is not compatible with, and does not support, the higher protocols of the higher bandwidth modem, which is also undesirable from an implementation standpoint. Stated another way, unlike the present invention, the lower end modem limitations of prior art system force the data link to be set up using a low level protocol that does not take advantage of the full capabilities of more advanced protocols.

20 Finally, there is no mechanism for users of either of the prior art systems noted above to expand the functionality of such modems in a controlled, flexible, and modular manner.

BRIEF DESCRIPTION OF THE DRAWINGS

30 Figure 1 is a pictorial depiction of the ADSL/DMT bandwidth allocation for upstream and downstream data in a channel based on frequency division multiplexing (FDM) configuration.  
Figure 1B shows the relationship between a sub-band filter and an analog to digital converter that can be used in an analog front end (AFE) of the present invention ;  
35 Figure 1C is a pictorial depiction of a SNR curve for a typical subscriber loop channel using sub-channel modulation;  
Figures 1D - 1G are mathematical modellings and charts that further explain the underlying physical premises of the present invention based on DMT ;  
Figure 2 is a block diagram of a general implementation of a communications system employing the present invention, adapted for use in an ADSL environment ;  
40 Figure 3A is a block diagram of a dedicated hardware implementation of a communications system employing the present invention, also adapted for use in an ADSL environment;  
Figure 3B is a block diagram of a mixed hardware and software based implementation of a communications system employing the present invention, also adapted for use in an ADSL environment;  
45 Figure 4 is a block diagram depicting the general structure of the data pump device driver used in the mixed implementation shown in Fig. 3;  
Figure 5 is a flowchart depicting the general operation of the control and application interface used in the mixed implementation shown in Fig. 3 ;  
Figure 6 is a block diagram of an implementation of a communications system employing the present invention, also adapted for use in an ADSL environment, in which it is depicted how a user can modularly expand throughput capability by adding additional AFE stages to process a greater percentage of the available bandwidth in the channel.

DETAILED DESCRIPTION OF THE INVENTION

55 While some of the concepts set forth immediately below are well-known, a brief explanation of ADSL technology is provided with reference to Figure 1 to facilitate an understanding of the present invention. As explained above, it is well-known in the art to use DMT to effectuate the ADSL standard. In contrast to most modulation schemes, such as AM/FM

transmissions that use one carrier, DMT uses multiple carriers to transmit data bits. Specifically, T1E1.4 ADSL standards specify an up to 255 channels for downstream transmission from the central office to subscribers and up to 31 channels for upstream transmission from subscribers to the central office. As shown in Figure 1, each carrier has a bandwidth of 4.3125 kHz. The total bandwidth is 1.1 MHz for a total of 255 channels. In the upstream direction, a "pilot" tone in the approximate range of 69 kHz, is used for maintaining timing synchronization. A similar pilot tone is transmitted in the downstream direction in the vicinity of 276 kHz.

Since upstream and downstream transmissions are over the same 2-pair twisted wire, they need to be separated by either echo cancellation (EC) or frequency division multiplexing (FDM). Echo cancellation allows simultaneous transmissions in both directions but requires a complex echo canceler implementation. On the other hand, FDM uses two different frequency bands for separate downstream and upstream transmissions. As shown in Figure 1, the upstream transmission uses subchannels from channel number 6 to 31, and the downstream transmission uses subchannels from channel number 41 to 255. While the remainder of the discussion below focuses on a system employing FDM, it will be appreciated by those skilled in the art that the present invention is adaptable and can be used beneficially with echo-cancellation approaches as well.

As with most communication environments, the transmission bit rates for both upstream and downstream communications in ADSL are not fixed but instead are determined by the quality of the channel. In the present invention, a number of well-known techniques can be used advantageously for setting up the initial data link. In general, these techniques work as follows: during initialization, the channel quality is measured and a certain data rate (typically a number of bits) is assigned for each DMT subchannel; thereafter, a "hand-shaking" process is used to dynamically and adaptively change the bit loadings (and energy levels). The latter is often necessary because (among other things) changes may occur in the overall channel characteristics, changes in the target bit rate may be needed, or new bit distributions in the sub-channels may be required because of degradations in one of the sub-channels.

The quality of the sub-channel response can be measured by the received signal to noise (SNR) ratio. According to the Shannon theorem, the upper limit of the number of bits per unit Hz that can be transmitted is  $\log_2(1+SNR)$ . Therefore, by measuring the received SNR at the receiver end, one can determine the number of bits allocated for each subchannel modulation. The total data throughput rate achieved by the system, therefore, is simply the sum of all the data rates of all the usable subchannels.

According to the T1 E1.4 ADSL standards, data bits are grouped and processed every 250  $\mu$ sec. The number of bits that can be processed over one such time frame is the summation of the bits allocated for each subchannel determined from the previous channel response measurement. For a given number of bits assigned to a certain subchannel, quadrature amplitude modulation (QAM) is used to convert bits to a complex value, which is then modulated by the subchannel carrier at the corresponding frequency.

The above is a merely a brief summary of the general operation of a typical DMT/ADSL communications system. The general circuits used in prior art ADSL systems, the specifics of the bit/energy loading process for the sub-channels, the bit fine tuning process, and the details of the modulation of the sub-channels, are well-known in the art, and will not be discussed at length herein except where such structures or procedures have been modified in accordance with the teachings herein.

The full downstream data throughput of a typical prior art ADSL standard transceiver approaches 6 Mbps, which is more than 200 times the speed of conventional analog modem technology. This requirement was imposed since a large part of the initial motivation to implement ADSL was to achieve high speed multimedia communications and video teleconferencing. Nevertheless, a large number of potential users do not want or need to have such wide bandwidth capability. For example, many potential users of ADSL (or similar high speed loops), including many who are intending to use such links primarily for Internet access, only need to achieve downstream transmission speeds that are in the hundreds of kilobits per second range. This data rate is in fact achievable using only a fraction of the available bandwidth of ADSL. By processing only a fraction of the available bandwidth of the ADSL standard, the present invention permits a limited but extremely useful ADSL modem to be implemented with significantly less expense and complexity than previously possible. At the same time, because the present invention has modular characteristics, the proposed implementation of the present invention affords users an easy path to forward and upward expansion of the overall functionality of their system.

The principle behind this aspect of the present invention is as follows: As shown in Fig. 1B, if the transmission in the channel is restricted to a smaller bandwidth by an anti-aliasing filter 80, according to the Nyquist sampling theorem, the sampling rate of AFE devices (such as ADC 81) that perform analog to digital conversion can be significantly reduced. Specifically, if the total downstream bandwidth is limited to some fractional total B Hz (in a preferred embodiment using DMT in an ADSL environment, B = 20 DMT channels or about 86 kHz) as shown below, we can limit the Nyquist sampling rate to around 180 kHz. This is achievable with ADCs having greatly simplified hardware and reduced performance requirements, in contrast to the full ADSL bandwidth approach, which processes 200 DMT channels or 900 kHz in the case of full ADSL implementation.

The total accumulated bit rate of an ADSL communications system using the present invention can be calculated

## EP 0 889 615 A2

as follows. Suppose a total number of  $k$  subchannels (out of a total of  $M$  possible) are to be supported and each channel is allocated  $b_k$  bits for transmission. The total accumulated bit rate ( $R$ ) is:

$$R = (\sum_{i=1,k} b_i) * 4 \text{ kHz (bits/sec)}$$

5

where 4 kHz is the framing rate defined by T1E1.4 ADSL standards. If  $k=20$  channels and the average number of bits per channel is 6, then total bit rate ( $R$ ) is approximately 480 kbits/sec. It can be seen that this fractional use of the ADSL bandwidth nevertheless provides about 9 times the performance of a conventional analog 56 kbits/sec digital modem. The benefits of this approach of the present invention are apparent. The overall performance and cost of a high speed communications system can be scaled and controlled in direct relationship to the particular needs of particular users. In general, the data rate supportable by (and the relative cost of) any particular implementation of the present invention is generally determined by two factors: (1) the capacity of the AFE; and (2) the capacity of the hardware performing the DMT.

10

The capacity of an AFE is generally measured by the maximum sampling speed it can achieve. As explained above, the sampling speed in turn determines the upper limit of the frequency band  $B$  (in kHz) that can be obtained. At the defined channel separation of 4.3125 kHz for ADSL, the total number of subchannels that can be supported is less than or equal to  $B/4.3125$ . A suitable ADC can be selected, therefore, based on the particular data rate and cost requirements of any particular user.

15

The other factor that limits the number of subchannels (and achievable data rate) is the processing power available for DMT modulation and demodulation routines. For example, a variety of performance levels (achievable data rates) are possible with well-known dedicated signal processing hardware, such as digital signal processors, as discussed in more detail below with reference to Figure 2. Alternatively, as shown in Figure 3, if such routines are implemented primarily by software and run by a host CPU, the required processing power (MIPS) generally increases directly as function of the number of subchannels that need to be processed. This is because, in general, most of the processings are done in serial, or a channel by channel basis. As discussed below in more detail, the present invention makes use of a "calibration" routine for estimating the total available processing power of a users computing system in order to set an upper limit of the total subchannels that can be supported.

20

25

Irrespective of the selection of the particular AFE or signal processing technique used, however, another useful (but not essential) aspect of the present invention is that the sub-channels with the largest signal to noise ratio (SNR) within the passband are selected for data transmission. In other words, in the preferred embodiment of the present invention, those  $k$  subchannels within the passband that support the largest number of bits are used for processing. As seen in Fig. 1C, for example, a standard two-wire subscriber line typically has a SNR curve that exhibits extensive attenuation with higher frequencies. It can be seen roughly in this figure that while there are more than 200 sub-channels provided for downstream transmission in ADSL, it is typically the case that 50% of the maximum data rate can be accomplished using only a much smaller percentage (than 50%) of the sub-channels. This fact is especially useful in considering some of the shared/ multi-channel bandwidth embodiments discussed further below.

30

35

The present invention, therefore, permits an implementation for a high speed data communications system that makes use of the best portion of the channel, while still being upwardly compatible and forward expandable. By these terms, it is meant that a system constructed in accordance with the teachings herein is completely compatible with a fully implemented version ADSL DMT modem. Moreover, it will be apparent to those skilled in the art that appropriate modifications specific to the channel and data link protocols and standards can be made so that the present invention can be advantageously employed in non-ADSL environments as well. Upward compatibility and forward expandability refer to the fact that systems constructed with the present teachings can have data rates that are easily upgraded while still preserving and maintaining compatibility with existing standards. For example, lower end users desiring less bandwidth can achieve a satisfactory performance with a minimum of cost, and can then upgrade the performance levels of their systems at later time by suitable (and preferably modular) upgrades of the AFE and signal processing hardware/software.

40

45

A system constructed in accordance with the present teachings is completely compatible with the full ADSL standard because of the following two aspects: According to the rate adaptation feature specified by the T1E1.4 ADSL standards, the bit rate for each sub-channel is determined initially (and preferably dynamically on an ongoing basis) by the sub-channel SNR analysis. Specifically, an ADSL downstream receiver can inform an upstream ADSL transmitter about the quality of the transmission; the receiver can also decide the bit rate for each sub-channel. Therefore, a downstream, partial-channel bandwidth receiver using the present invention can (based on the speed and passband of such receiver) supply an upstream, full-standard ADSL transmitter with information or control signals to effectuate a transmission only in selected sub-channels. In particular, in a preferred embodiment, the upstream ADSL transmitter is provided with SNR information for sub-channels outside the passband that is artificially contrived so as to suggest to the upstream transmitter that these sub-channels are not usable. In this manner, the downstream transmission is limited to a certain number of subchannels within the AFE and signal processing capabilities of the receiver. It can be seen, nev-

55

ertheless, that this scheme is completely transparent to the transmitter, thereby permitting a system built in accordance with the present teachings to be fully compatible with the ADSL standard. While not possible at this time within the ADSL standard, it is apparent that other high-speed data protocols may use a control signal, instead, to provide for express limiting and control of the identity of the sub-channels transmitting information.

5 As the technology improves for AFE devices and DMT implementation, the number of subchannels supported by a system using the present invention can increase. As a result, such systems can upgrade completely to a full T1E1.4 ADSL implementation using a single higher end modular replacement APE devices, or alternatively, a number of lower end modular AFE devices.

#### 10 GENERAL EMBODIMENT OF PRESENT INVENTION

The basic structure of the present invention is depicted generally in Fig. 2. In general, the present invention can be embodied in different combinations of hardware and software. The primary difference between these embodiments is the specific implementation of the DMT core. These specific embodiments are described in more detail below with reference to Figs. 3A and 3B.

The structure and operation of ADSL transceivers is well-known in the art, and for that reason the present description primarily details those aspects of such transceivers which are necessary to an understanding of the inventions herein. As seen in Fig. 2, a channel 100 is made of a regular copper wire "loop", and each such loop may have differing electrical properties, transmission lengths (sizes), varying attenuation characteristics, and a number of impairments or interferences. Splitter 210, a conventional and well-known circuit, separates a DMT signal occupying more than 200 sub-channels from a lower end 4 kHz POTS analog signal. The latter can be used for simultaneous voice or conventional analog modem. Hybrid circuit 220 is also well-known in the art, and consists primarily of conventional transformers and isolation circuitry used in a wide variety of high-speed devices interfacing to standard telephone lines. A ring detect logic circuit 290 can also be implemented using accepted techniques, to alert a Control Interface 295 to the existence of a transmission signal originating from an upstream transceiver (not shown).

The full bandwidth signal is either low passed or bandpass limited to a frequency width B by suitable, well-known techniques as it passes through bandpass Filter and Analog/Digital Converter 280, so that only a fraction of the signal in the frequency domain is passed on to Buffer and DMT Receive Core 260. Again, the only important consideration for Subband Filter 280 is that it must constrain the bandwidth of the incoming signal to be  $\leq B$ , where the sampling rate of the Analog/Digital Converter is  $\geq 2B$ . This can be accomplished by using well-known filter designs. By suitable selection of circuitry for Filter and ADC 280, the overall system cost and performance can be scaled accordingly. In a preferred embodiment, the signal passed through Filter and ADC 280 occupies a spectrum between approximately 200 and 400 kHz. This selection is based primarily on an expected average performance of a typical two-wire line. It will be apparent to those skilled in the art that different bandpass widths and regions may be more suitable or optimal for other kinds of data links, or other kinds of multi-carrier modulation schemes.

Moreover, in some instances, while it is somewhat more expensive to implement, an adaptive or tunable filter may be substituted, such that the target frequencies of the passband are adjustable uniquely for each new data link. In such cases, the bandpass can be configured to coincide with the sub-channels having the highest achievable SNR, including the subchannels that must be supported for protocol or other system overhead reasons. Also, in some applications, the analog-to-digital conversion may be performed by a digital signal processor, or by the host computer and therefore, the sampling rate can be dynamically controlled and matched to the bandpass target frequency and frequency breadth. This feature, in turn, would assist dynamic scaling of the data throughput based on system computing power and overhead requirements.

Furthermore, in this preferred embodiment, using a multi-carrier approach implementation for ADSL, a pilot tone at 276 kHz must be allowed within the passband. It is apparent that other protocols may require similar pilot tones, and the design of comparable filters to achieve the functionality of Filter and ADC 280 is well within the ordinary skill of one in the art.

DMT Receiver Core 260 is generally responsible for monitoring and measuring the SNR of the sub-channels falling within the frequency range passed by FILTER and ADC 280, and for extracting the original data stream from the numerous sub-carriers. In a preferred embodiment, Control Interface 295 receives system configuration information from a host 298. This information may contain such parameters as target throughput rate R, target error rate, target center frequencies F for FILTER and ADC 280, target frequency width B, etc. By evaluating the SNR and bit capacities of the sub-channels computed by DMT Receiver Core 260, and taking into consideration the target data rate R, Control Interface 295 can select a number k of sub-channels up to and including the total available number M of sub-channels to carry the data stream from the upstream transmitter (not shown). The number of sub-channels that can be used for carrying data is directly related to the bandpass frequency B as described above. In a preferred embodiment,  $M = 200+$  (ADSL) and Control Interface 295 will usually configure  $k = 20$ .

For every sub-channel other than the selected k sub-channels, a "mask" or blackout control/feedback signal is gen-

erated and transmitted by DMT Tx Core 250, Buffer 260 and DAC 230 to the upstream transceiver. This ensures that any subsequent data transmissions by the upstream transceiver only use the selected  $k$  sub-channels. This feedback information is provided, therefore, irrespective of the transmitting capacity of the upstream transceiver, and even during times when the channel 100 is capable of supporting more than  $k$  sub-channels. In this manner, the present system is perceived by upstream transceiver to be compatible with protocols and performance characteristics of the upstream transceiver, because the upstream transmitter receives feedback information indicating merely that the two systems are connected through a channel with substantial signal attenuation characteristics for data signals outside the  $k$  sub-channels. Based on the inherent rate adaptiveness of ADSL and other similar protocols, the upstream transceiver will automatically train itself to use only the  $k$  sub-channels predetermined by the downstream transceiver. It should be noted that the DAC 230 and Buffer 240 in the front end transmitting circuit preferably transmit any upstream data transmissions using a second frequency bandwidth different from that of the downstream data transmission. However, this is not necessary in systems using echo-cancellation. Furthermore, in ADSL applications, the size of this bandwidth is considerably smaller, and uses only  $L$  sub-channels, where  $L < M$ . In other xDSL applications,  $L$  may be on the same order or larger than  $M$ .

Again, while the ADSL standard fixes the data error rate to be  $10^{-7}$ , it is conceivable that other applications of the present invention may tolerate a reduced error rate. For example, if maximum data throughput is required (i.e., the margin is less constrained) then the largest bit capacity sub-channels within  $B$  can be selected. Alternatively, if the system is error-performance driven and has more relaxed throughput requirements, then the 20 subchannels with the best margin are selected. A suitable combination of sub-channels can be selected by one skilled in the art based on the particular system requirements which may vary from application to application. Moreover, Controller Interface 295 may optimize the desired sub-channel mix dynamically depending on the type of data transmitted in channel 100. For example, streaming audio or video, or pictorial graphics, may require less integrity and error performance than other kinds of data used by  $n$  applications programs running on host 298. The specifics of the structure, operations and techniques used by Controller Interface 295 are not constrained by any requirements of the present invention, and can be implemented in various ways well-known to those skilled in the art.

The operation of the remainder of the circuitry shown in Fig. 2 is also relatively straightforward and not unlike a typical multi-carrier modulation system. Control Interface 295 ensures that DMT Transmit Core 250 performs bit and energy loading only for those sub-carriers necessary to effectuate a selected host throughput rate/error rate combination. As with the circuitry used for Filter ADC 280, the circuitry for performing the functions of DAC 230 can be implemented in programmable form to allow for greater flexibility.

Finally, while not presently supported in ADSL protocols, it is nevertheless possible that the filter in block 280 can be eliminated entirely in some applications when the sub-channel or downstream transmission frequencies can be configured through appropriate handshaking or similar procedures. In other words, if the upstream transmitter can be configured to transmit using only a portion of the bandwidth available in the channel, the advantages of the present invention can still be realized, because the ADC portion of block 280 can still be relatively less complex, since it will be processing at a much slower sampling rate than that required for a full spectrum implementation. Moreover, such an implementation would also yield the same commensurate savings in the DMT processing core, and reduced quantization errors.

Some special features of the present invention include the fact that:

(i) unlike hardware architectures implementing a full T1E1.4 ADSL standard, the present invention uses a filter in the front end. As mentioned earlier, the use of this filter is to allow low speed sampling by the ADC. If suitable handshaking between the upstream and downstream transceivers can be effectuated to generate a reduced downstream transmission, the filter can be eliminated.

(ii) standard ring detection logic is incorporated to support existing modem features;

(ii) DMT Rx core 260 is basically implemented the same way as specified by T1E1.4, but with some important differences, specifically:

[a] due to subband filtering and lower speed sampling, the frequency channels at the output of FFT (not shown) in the DMT Rx Core have a frequency shift

[b] Since not all 256 subchannels are necessarily supported by the DMT Rx Core 260, actual FFT implementation can be smaller, simpler and more cost-effective;

(iv) Control logic 295 permits the system to behave essentially like a conventional analog modem, and is used to support necessary setup tasks such as dialing and handshaking;

(v) The use of limited bandwidth from the downstream channel reduces the need for echo-cancellation circuitry, because there is less need for overlap between the upstream and downstream transmissions, and this further reduces system complexity and cost;

(vi) Because a smaller portion of the spectrum is processed by the present invention, the peak-to-peak deviation of the downstream signal is reduced, and this helps to minimize quantization errors.

#### DEDICATED HARDWARE BASED EMBODIMENT

Figure 3A illustrates an embodiment of the present invention that can be generally described as a dedicated hardware implementation. For the present discussion of Fig. 3A, it can be assumed that those circuits having like numbered references are the same and/or perform the same function as their counterpart in Fig. 2. For example, unless otherwise indicated, there is no material difference between Splitter 210 (Fig. 2) and Splitter 310 (Fig. 3A).

In this embodiment, the DMT sub-channel modulation core is implemented completely in dedicated processing hardware. For thin application, DMT Receiver Core 260 typically includes a digital signal processor (DSP) (not shown) and including on-board program ROM (or other suitable memory) for storing executable microcode routines for performing bit, energy and SNR measurements of the carriers in the sub-channels. In such an embodiment, due to the power of the DSP, there is typically no need for processing assistance from a user's host processor 398. This embodiment therefore may be advantageously employed where host processing power limitations are a consideration.

A user of a system shown in Fig. 3A can expand the functionality (i.e., data throughput rate and modem features) of such system by upgrading the DMT Receiver Core 260, and where necessary, the AFE 280 as well. The system of Fig. 3A can be incorporated on a typical printed circuit board. By mounting or packaging the circuits used in such blocks in an accessible fashion, they can be replaced or supplemented much in the same way present users of personal computers can upgrade their motherboards to include additional DRAM. One practical alternative, for example, would be to have multiple available slots to accommodate new subband pass filters for passing a greater portion of the downstream transmission to be processed by the DMT core logic. Other practical and simple variations of this approach will be apparent to those skilled in the art.

#### PARTIAL SOFTWARE BASED EMBODIMENT

In the above dedicated hardware embodiment, the overall speed (data throughput) can be maximized but with less flexibility for upgrades. This is because upgrades to such a system must take the form of hardware replacements, which can be more costly and difficult for the user to incorporate. On the other hand, as depicted in Fig. 3B, a number of important functions of a communications system can be completely implemented in software, in an analogous fashion to what is commonly described in the art as a "software" modem. In this case, the overall speed of the system depends on the user's processor power available at host 398, and only the AFE portion need be implemented in hardware.

The primary differences between the embodiments of Fig. 3A and 3B are the following: (1) implementation of DMT modulation; (2) implementation of the control and handshaking functions; and (3) implementation of the control interface. As seen in Figures 3B and 4, DMT Receive Core 460 and DMT Transmit Core 450 are implemented in a data pump device driver by the host system 398. In a preferred embodiment, host system 398 includes some form of multi-purpose microprocessor (such as an x86 type processor) running a suitable operating system (such as Windows by Microsoft), and is capable of executing suitable low level drivers for the DMT modulation (Fig. 4), as well as high level application software for implementing Control Interface 500 (Fig. 5). Host processor system 398 communicates over a standard bus interface 385 (i.e., a PCI bus) to Front End circuitry 396 for implementing a high speed modem. As with the circuitry in conventional analog modems, this circuitry of the present invention can be effectively incorporated on a PC motherboard (i.e., Bus Interface 385 and Front End Circuitry 396 can be merged so that they are essentially part of host system 398) or on a separate printed circuit board, or as a stand-alone unit physically separated from host 398. While this approach may not provide as much throughput performance, it has the advantage of being less expensive than the pure hardware approach of Fig. 2, and much easier to upgrade.

In the "software" modem implementation of Fig. 3 using a typical PC running Windows, the DMT Tx core 450, Rx Core 460 and Control/Handshaking logic are implemented as a Windows Data Pump Device Driver 400, which consist of DMT routines, associated control and handshaking codes, and an interface to kernel 480.

A more detailed characterization of a portion of host processing system 398 is depicted in Fig. 4, which illustrates a preferred embodiment of a device driver 400 as it would be constituted for a computer operating system shell 480. In the present embodiment, Microsoft Windows NT is considered, but it is understood that other comparable environments may be used, including UNIX, Windows 95, etc. As is well-known, operating system 480 is responsible for supervising and controlling the operation of processing system 398 and all of its associated peripheral devices. Operating system 480 also includes various interactive control and graphical application interfaces (Fig. 5) for permitting a user of processing system 398 to run various applications programs, and to set up, control, configure, monitor and utilize peripheral devices such as disk drives, printers, monitors, modems and the like.

To assist operating system 480 to interact and control such peripheral devices, it is also well-known to use device drivers, which are essentially low-level hardware routines executed by a host processor and operating system. A device

driver is a memory image file or executable file that contains all the code necessary to instruct a host processor to interface and drive a particular device within a computing system. Device driver 400 acts as an interface between an operating system 480 (in this case, Microsoft Windows NT) and hardware 396. In this case, for example, device driver 400 supports hardware 396 (see Fig. 3B), which is embodied in a typical printed circuit board (or external device). The teachings herein therefore provide for a new device driver that in combination with hardware 396 operates as a "software" modem. In this manner, operating system 480 classifies this combination as an ADSL modem, or in other words, another typical personal computer peripheral device, analogous to conventional voice-band modems.

Generally speaking, device driver 400 works as follows: a user of processing system 398 desiring to establish a data link to a remote site for transmitting/receiving data initiates such link through an application program (Fig. 5). Operating system 480 (Fig. 4) interprets and services this request by passing control of this task to device driver 400, which first generates appropriate instructions for a Device Initialization 440. In a preferred embodiment, Modem card 396 is initialized through Bus Interface 410 using conventional voice band modem control commands, so that the present invention is compatible with preexisting applications programs written for controlling modems using operating system 480. Similarly, therefore, control and data signals are interpreted and transmitted by operating system 480 to a Serial Port Interface 475 so that conventional modem dialing instructions and handshaking signals can be imparted to Modem Card 396 to establish a link through channel 100 to an upstream conventional ADSL transceiver (not shown). As explained above, after suitable handshaking protocols have been completed, the upstream fully compatible ADSL transceiver will begin transmitting data on all available M usable sub-channels. This downstream data is filtered by FILTER/ADC 380 and at this time, information for only N sub-channels ( $N \leq M$ ) is temporarily held in Buffer 370. At or before this same time, an interrupt is generated by bus interface 385 and passed through device driver bus interface 410 to alert Interrupt Service Router 415 to the existence of downstream data requiring processing. Thereafter, DMT Receive Core 460 begins processing the downstream data stream in response to control information from ISR 415. A demultiplexer 465 extracts and correlates the data in the various sub-channels before passing it on to Serial Port Interface 470, and back to Operating System 480. In this manner, Device Driver 400 coordinates with Modem card 396 to effectuate a software modem whose performance is directly correlated to the computing power of a processor contained within the host processing device.

As mentioned earlier, Device Driver 400 also contains control information for configuring the number and selection of sub-channels to be used in the particular data link established through channel 100 with the upstream transceiver during an initialization process. As also mentioned above, this control information may be self-determined by a user of host processing system 398, or alternatively, automatically sensed and monitored by such processing system, based on a computing performance rating for such system determined in a calibration routine. In either event, during the initialization process (and at all times subsequent) the upstream transceiver is induced to use such sub-channels only for the ensuing data transmission. This is accomplished by transmitting SNR information that is interpreted by the upstream transceiver as zero for all but  $K \leq N$  of the sub-channels of the driver selection. This data is passed under control of Operating System 480 through Serial Port 475, Framing Control 455 and DMT Transmit Core 450 before being sent out to Modem Card 396 and channel 100.

It is understood, of course, that ADSL Modem 396 can also respond to a request from a remote modem for initiating the data link. The process for initializing the link, nevertheless, is essentially the same as that described above. Device driver 400 can also contain control logic for supporting typical dial-up modem operations and control codes from conventional modem application programs typically implemented in voice-band modems, such as setting up Originate/Answer modes, monitoring call progress, performing modem diagnostics, configuring receive/transmit buffer sizes, supporting facsimile transmissions, as well as performing enhanced error control, data compression and flow control between Modem Card 396 and Operating System 480. Device Driver 400 can also support other conventional "always-on" data link connections as desired, such as may be found in typical ethernet network connections, and other dedicated applications.

Given the teachings of the present invention, the general design of the above Data Pump Device Driver 400 is a routine task well within the abilities of one skilled in the art. The specifics of such implementation are not critical or essential to the present inventions, and will vary from application to application according to system designer requirements, so they are not included here. Again, while this embodiment of the present invention is set out in the context of a PC based host processor running Windows, it will be apparent to those skilled in the art that above description is merely an exemplary implementation. The referenced DMT routines, associated control and handshaking codes can be employed in numerous host processing/operating system environments, and in a variety of different coding organizations (high level or low level processing forms) well-known in the

In the preferred embodiment implemented using a standard PC running Windows, Control/Application interface 500 includes Win32 codes which provide standard modem utility functions and interface with Data Pump Device Driver 400. In Fig. 5, a flowchart of the operation of the Control/Application Interface 500 can be seen, which interface is discussed in more detail below.

Another particularly beneficial aspect of the embodiment of Fig. 3B is the provision of a self-determining "perform-

ance" or calibration rating that can be used to determine an optimal or maximum data throughput rate. In other words, the system of Fig. 3B can automatically and adaptively configure a host system 398 to a particular throughput rate based on an evaluation of the available computing power. In a preferred embodiment, the performance rating is determined based on a calibration routine executed by Data Pump Device Driver 400. This routine sets a timer, and counts  
 5 how many DMT frames can be processed within the given time; this gives a relative figure of merit for the particular host system in question. For each sub-channel to be added, one DMT frame needs to be processed within a small fraction of 250  $\mu$ s. Therefore, by incrementally increasing the sub-channel count, the overall effect on total system processing overhead can be determined. Control/Application Interface 500 provides the user with control to set a threshold of available host power for implementing the high speed link. Based on this threshold of available power (which can be nominally set to 20%) the number of subchannels that can be supported can be gleaned very quickly.  
 10

In view of current technology, when DMT processing is implemented in software, the host processing power is more likely to be the limiting factor than the frequency band of the subband filter 80 in Figure 1B. Nevertheless, because host processors (and especially microprocessors) are evolving in performance at a fairly rapid rate, the present invention affords users an opportunity to realize a high speed data link with performance that is controllable, and which improves  
 15 whenever there is an upgrade in the host processing system. Since many typical present day personal computer systems have easily accessible and replaceable host processors, users of the present invention can easily and flexibly expand and enhance the throughput and functionality of an ADSL modem.

An example of the flow chart for an ADSL modem application/control program 500 designed in accordance with the present teachings is shown in Fig. 5. With the teachings herein, a user of host processing system 398 can, for the first time, dynamically control a forward compatible and expandable modem, such as an ADSL modem, using modem-control applications software that is analogous to that only previously available for voice band modems. In a preferred embodiment, ADSL Modem Card 396 is automatically detected by Operating System 480 and set up by initialization routine 505 by Modem Device Driver 400. A separate detection routine 510 determines whether or not ADSL Modem Card 396 has been upgraded with an additional AFE (as described generally with reference to Figure 6 below), or alternatively whether a processor used in a host system has changed. The purpose of this step is primarily to determine  
 20 whether entries in a Device Parameters Table 560 need to be updated because of changes in computing power, front end capabilities or other parameters that may necessitate a modification of the data throughput characterization of the overall system when used in a communications mode.

A calibration routine 520 is then executed to determine the nominal setup parameters for the overall system in the manner described earlier. The results from this operation are stored in Device Parameter Table 560 where they then become accessible to various application programs that may make use of ADSL Modem Card 396 and Device Driver 400. The information stored in table 560 can include any or all of the following (a) measurements of the computing power available to the host processor; (b) measurements of the number of frames processable by the system within a particular time period; (c) estimations of the expected loading on the processing system based on demands of other  
 35 applications programs and peripheral devices; (d) minimum and maximum data throughput estimations and/or targets; (e) data identifying the type of host processor; (f) data identifying the number and type of AFEs in ADSL Modem card 396; (g) estimations and/or target system loading rates available for a datalink (i.e., maximum available processing time to be used by the system during data transmission); (h) data transmit and receive buffer sizes; (i) interrupt or similar priority data for the modem card; (j) estimations and/or target system sub-channel utilization; (k) estimations and/or target system sub-channel bit capacity information, etc. It will be apparent to skilled artisans that the above are just examples of the types of information that may be pertinent to the performance of a high speed communications system, and that other parameters may be considered depending on the environment, application, etc. in which the present invention is used.

After performing Auto Calibration routine 520, the results of the same are presented to the user for acceptance and verification at step 525. At this point, the user can accept the predetermined configuration data at step 526 (i.e., such as proposed maximum and minimum throughput rates, loading rates, etc.) and this would otherwise invoke an end of modem setup routine 590. Should the user not want to accept the recommended parameters, a Manual Configuration routine 530 is executed. At this juncture, various system performance data can be presented to the user for review, along with a list of modifiable system options 532. If for example, the user elects to increase the desired throughput rate,  
 50 a Verification routine 540 is then executed to determine whether such rate is reasonably sustainable within the other parameters of the system. If the new proposed configuration data is otherwise acceptable, then the Device Parameter Table 560 is updated, and the setup routine again ends. Otherwise, the user is alerted by a Notification/Suggestion routine 550, which points out the failure of the proposed configuration, and, if possible, makes suggestions to the user for modifying the system options 532 so that overall compliance can be achieved within the performance capability of the host processing system. The program then loops back to Acceptance routine 525, and thereafter the process is repeated until an acceptable configuration has been achieved, and any changes have been incorporated into Device Parameter Table 560.

While some of the operational steps above are described as implemented solely by Operating system 480 and



Device Driver 400, it is understood that such operations occur under direction of modem applications program 500, or in some cases, based on initialization routines executed by the host processing system. Moreover, to simplify the presentation of the present invention, only some of the features that may be implemented are described above, and many other well-known operational steps normally associated with setting up or monitoring modems are omitted.

5 As with the design of the above Data Pump Device Driver 400, the general design of the Control/Application Interface 500 required to accomplish the above functions is a routine task well within the abilities of one skilled in the art given the teachings herein. The specifics of such implementation are not critical or essential to the present inventions, and will vary from application to application according to system designer requirements, so they are not included here. Again, while this embodiment of the present invention is set out in the context of a PC based host processor running  
 10 Windows, it will be apparent to those skilled in the art that above description is merely an exemplary implementation. The referenced Control/Application Interface can be employed in numerous host processing/operating system environments, and in a variety of different coding organizations (high level or low level processing forms) well-known in the art.

*MULTIPLE AFE AND LOWER SAMPLING SPEED EMBODIMENT*

15 Figure 6 illustrates an example of the present invention wherein a user can achieve significantly increased data throughput using multiple low cost, low sampling speed AFEs, generally designated 680A, 680B, 680C, etc. As described above, these AFEs may be in separate, modular form and configured in a bank form so that they can be incorporated conveniently on a printed circuit board (or similar mounting) or integrated in a single IC chip. Each AFE  
 20 can be implemented in a fixed hardware configuration, or individually programmed/controlled to pass a certain portion of the downstream data transmission. Assuming suitable processing power is available for DMT modulation/demodulation (either through a dedicated or software implementation as described above in connection with Figs. 3A and 3B) a user of such system can achieve substantially expanded functionality by upgrades having performance characteristics and costs of their choice.

*UNDERLYING THEORY OF PRESENT INVENTION FOR ADSL/DMT APPLICATIONS*

25 A discussion of the underlying theory supporting the premise of the present invention now follows. In particular, this section shows the mathematical foundation For the use of multiple low speed AFE's to sample a full bandwidth ADSL/DMT signal. It will be apparent to those skilled in the art, after reading this discussion, that the present inventions can be advantageously used in a number of rate adaptable communications environments, including CAP implementations of ADSL.

**DMT Transmitter**

35 To simplify the present discussion, only a subset of the DMT transmitter is considered, as shown in Figs 1D and 1E. The combined model that includes the channel response and the DMT receiver is shown below, where only one branch of band-pass filtering and sampling is shown for simplicity. To further simplify, the channel response and the SFIR are combined together.

40 In this subsection, we analyze the signal over one band pass filtering process. The result shows that the DMT signals within the band pass can be recovered with the same use of impulse response shortening technique. With use of multiple AFE's that cover different frequency bands, all DMT subchannels can be recovered. IFFT

In an ADSL environment as shown in Fig. 1D,  $N$  ( $N=512$ ) frequency domain variables are transformed into the time domain by IFFT block 60

45

$$y_n = \sum_{i=0}^{N-1} x_n e^{j2\pi i n / N}$$

**Cyclic Prefix**

50  $c$  time domain variables at the end are added to the prefix of the sequence as shown in Fig. 1D by block 70  
 $\{z_n\} = \{z_{-c}, z_{-c+1}, \dots, z_{-1}, z_0, z_1, \dots, z_{N-1}\} = \{y_{N-c}, \dots, y_{N-1}, y_0, \dots, y_{N-1}\}$

**AFE/DAC**

Discrete time domain sequence are converted by AFE 75 to the continuous time domain waveform as follows:

**EP 0 889 615 A2**

$$z(t) = \sum_{n=-\infty}^{\infty} z_n \rho_{TX}(t-nT_c),$$

5 where  $\rho_{TX}(t)$  is the transmitter pulse of the AFE/DAC used, and  $T_c$  is the transmitter DAC clock period and equal to

$$T_c = \frac{250 \mu\text{sec}}{N+C}$$

10 according to the DMT ADSL specifications.

**Channel**

With reference now to Fig. 1E, if the channel impulse response is  $h_c(t)$ , we have

15

$$u(t) = \sum_{n=-\infty}^{\infty} z_n \rho_{RX}(t-nT_c)$$

20 where  $\rho_{RX}(t) = \rho_{TX}(t) \otimes h_c(t)$ .

**Bandpass Filtering**

If the bandpass filter 80 has an impulse response of

25

$$h_{BPF}(t), v(t) = \sum_{n=-\infty}^{\infty} z_n \rho_{BPF}(t-nT_c)$$

30 where  $\rho_{BPF}(t) = \rho_{RX}(t) \otimes h_{BPF}(t)$ .

**AFE/ADC**

Let the sampling clock be  $T_s = T_c \times L$ . This means a slower sampling by a factor of  $L$  for AFE 81. Thus,

35

$$w_k = \sum_{n=-\infty}^{\infty} z_n \rho_{BPF}(kT_s - nT_c) = \sum_{n=-\infty}^{\infty} z_n \rho_{BPF}([kL - n]T_c)$$

40 For causal pulse  $\rho_{BPF}(t)$ , we have

$$w_k = \sum_{n=-\infty}^{\infty} z_n \rho_{BPF}([kL - n]T_c) = \sum_{n=0}^{\infty} z_{kL-n} \rho_{BPF}(nT_c)$$

45

**Shortening FIR (SFIR)**

After AFE discrete time sampling, a time domain equalizer (TEQ) called SFIR 82 is used to reduce the combined discrete time impulse response to a duration smaller than  $c$ . If the SFIR response is  $h_{SFIR}[n]$ , we have

50

55

$$\begin{aligned}
 r_k &= \sum_{i=0}^{\infty} w_{k-i} h_{SFIR}[i] \\
 &= \sum_{i=0}^{\infty} \left[ \sum_{n=-\infty}^{\infty} z_n p_{BPF}((kL-n-iL)T_c) \right] h_{SFIR}[i] \\
 &= \sum_{n=-\infty}^{\infty} z_n h_{tot}[kL-n] \\
 &= \sum_{n=0}^{\infty} z_{kL-n} h_{tot}[n]
 \end{aligned}$$

where

$$h_{tot}[kL-n] = \sum_{i=0}^{\infty} h_{SFIR}[i] p_{BPF}((kL-n-iL)T_c)$$

20 **Physical Meaning of  $h_{tot}[n]$**

If we perform discrete Fourier transform at block 84 for  $h_{tot}[n]$ , we obtain  $H_{tot}[\omega] = H_{SFIR}[L\omega] H_{BPF}[\omega]$  where  $H_{SFIR}[L\omega]$  and  $H_{BPF}[\omega]$  are the DFT's with period  $1/(LT_c)$  and  $1/T_c$ , respectively. Their spectra can be illustrated as shown in Fig. 1F for  $L=5$ .

25 **Dropping Cyclic Prefix**

By dropping the cyclic prefix of length  $c/L$ , at block 83 we consider only  $s_k = r_k, k=0, \dots, N_1-1$ , where  $N_1 = N/L$ .

30 **FFT**

Performing FFT at block 84 for  $s_k, k=0, \dots, (N/L)-1$ , one obtains:

$$\begin{aligned}
 q_n &= \sum_{l=0}^{N_1-1} s_l e^{-j2\pi nl/N_1} \\
 &= \sum_{k=0}^{N_1-1} r_k e^{-j2\pi nk/N_1} \\
 &= \sum_{k=0}^{N_1-1} \left( \sum_{i=0}^{\infty} z_{kL-i} h_{tot}[i] \right) e^{-j2\pi nk/N_1} \\
 &= \sum_{k=0}^{N_1-1} \sum_{i=0}^{\infty} z_{kL-i} h_{tot}[i] e^{-j2\pi n(kL-i)/N_1} e^{-j2\pi ni/N_1} \\
 &= \sum_{i=0}^{\infty} \sum_{k=0}^{N_1-1} z_{kL-i} e^{-j2\pi n(kL-i)/N_1} h_{tot}[i] e^{-j2\pi ni/N_1} \\
 &= \sum_{i=0}^c \sum_{k=0}^{N_1-1} z_{kL-i} e^{-j2\pi n(kL-i)/N_1} h_{tot}[i] e^{-j2\pi ni/N_1} \\
 &= \sum_{i=0}^c \sum_{k=0}^{N_1-1} y_{kL-i} e^{-j2\pi n(kL-i)/N_1} h_{tot}[i] e^{-j2\pi ni/N_1}
 \end{aligned}$$

where we assume  $h_{tot}[i]$  is only nonzero for  $i = 0, \dots, c$ . For a given  $i$ , let us define

$$l' = \lceil i/L \rceil;$$

5

We can then define  $i' = l'L - i$ , where  $i' = 0, \dots, L-1$ . Therefore,  $i = l'L - i'$   
 From the above definitions, we have

$$\begin{aligned} \sum_{k=0}^{N_1-1} y_{kL-i} e^{-j2\pi n(kL-i)/N_1} &= \sum_{k=0}^{l'-1} y_{kL-i} e^{-j2\pi n(kL-i)/N_1} + \sum_{k=l'}^{N_1-1} y_{kL-i} e^{-j2\pi n(kL-i)/N_1} \\ &= \sum_{k=0}^{l'-1} y_{(k-l')L+i'} e^{-j2\pi n((k-l')L+i')/N_1} + \sum_{k=l'}^{N_1-1} y_{(k-l')L+i'} e^{-j2\pi n((k-l')L+i')/N_1} \\ &= \sum_{k=0}^{l'-1} y_{(k-l'+N_1)L+i'} e^{-j2\pi n((k-l'+N_1)L+i')/N_1} + \sum_{k=0}^{N_1-1-l'} y_{kL+i'} e^{-j2\pi n(kL+i')/N_1} \\ &= \sum_{k=N_1-l'}^{N_1-1} y_{kL+i'} e^{-j2\pi n(kL+i')/N_1} + \sum_{k=0}^{N_1-1-l'} y_{kL+i'} e^{-j2\pi n(kL+i')/N_1} \\ &= \sum_{k=0}^{N_1-1} y_{kL+i'} e^{-j2\pi n(kL+i')/N_1} \end{aligned}$$

25

Therefore,

$$\begin{aligned} q_n &= \sum_{i=0}^c \sum_{k=0}^{N_1-1} y_{kL-i} e^{-j2\pi n(kL-i)/N_1} h_{tot}[i] e^{-j2\pi ni/N_1} \\ &= \sum_{i=0}^c \left[ \sum_{k=0}^{N_1-1} y_{kL+i'} e^{-j2\pi n(kL+i')/N_1} \right] h_{tot}[i] e^{-j2\pi ni/N_1} \\ &= \sum_{i=0}^c \left[ \sum_{k=0}^{N_1-1} \left( \sum_{l=0}^{N-1} x_l e^{j2\pi(kL+i')l/N} \right) e^{-j2\pi n(kL+i')/N_1} \right] h_{tot}[i] e^{-j2\pi ni/N_1} \\ &= \sum_{i=0}^c \left[ \sum_{k=0}^{N_1-1} \sum_{l=0}^{N-1} x_l e^{j2\pi(kL+i')(l-n)/N} \right] h_{tot}[i] e^{-j2\pi ni/N_1} \\ &= \sum_{i=0}^c \left[ \sum_{l=0}^{N-1} x_l \sum_{k=0}^{N_1-1} e^{j2\pi(kL+i')(l-n)/N} \right] h_{tot}[i] e^{-j2\pi ni/N_1} \end{aligned}$$

45

Since

$$\sum_{k=0}^{N_1-1} e^{j2\pi(kL+i')(l-n)/N} = 0 \text{ when } (l-n) \neq mN_1,$$

50

we have

$$q_n = N_1 \sum_{i=0}^c \left[ \sum_{m=0}^{L-1} x_{mN_1+n} e^{j2\pi i' m/L} \right] h_{tot}[i] e^{-j2\pi ni/N_1}$$

55

Knowing that  $h_{tot}[l]$  is zero for  $l < 0$  and  $l > c$ , we have

$$\begin{aligned}
 q_n &= N_1 \sum_{i=0}^c \left[ \sum_{m=0}^{L-1} x_{mN_1+n} e^{j2\pi i'm/L} \right] h_{tot}[i] e^{-j2\pi ni/N_1} \\
 &= N_1 \sum_{i=-\infty}^{\infty} \left[ \sum_{m=0}^{L-1} x_{mN_1+n} e^{j2\pi i'm/L} \right] h_{tot}[i] e^{-j2\pi ni/N_1} \\
 &= N_1 \sum_{l=-\infty}^{\infty} \sum_{i'=0}^{L-1} \left[ \sum_{m=0}^{L-1} x_{mN_1+n} e^{j2\pi i'm/L} \right] h_{tot}[lL-i'] e^{-j2\pi n(lL-i')/N} \\
 &= N_1 \sum_{m=0}^{L-1} x_{mN_1+n} \sum_{i'=0}^{L-1} e^{j2\pi i'm/L} \sum_{l=-\infty}^{\infty} h_{tot}[lL-i'] e^{-j2\pi n(lL-i')/N}
 \end{aligned}$$

Since

$$\begin{aligned}
 \sum_{l=-\infty}^{\infty} h_{tot}[lL-i'] e^{-j2\pi n(lL-i')/N} &= \sum_{l=-\infty}^{\infty} h_{tot}[lL-i'] e^{-j\omega(lL-i')T_c} \Big|_{\omega=2\pi n/N_1} \\
 &= F \left\{ h_{tot}(t) \sum_l \delta(t - [lL-i']T_c) \right\} \Big|_{\omega=2\pi n/N_1} \\
 &= \frac{1}{2\pi} \mathcal{F}_{tot}(\omega) \otimes \left[ \frac{2\pi}{LT_c} \sum_l \delta(\omega - \frac{2\pi l}{LT_c}) e^{j2\pi l i'/L} \right] \Big|_{\omega=2\pi n/N_1} \\
 &= \frac{1}{LT_c} \sum_l \mathcal{F}_{tot}(\frac{2\pi n}{NT_c} - \frac{2\pi l}{LT_c}) e^{j2\pi l i'/L}
 \end{aligned}$$

we have

$$\begin{aligned}
 q_n &= N_1 \sum_{m=0}^{L-1} x_{mN_1+n} \sum_{i'=0}^{L-1} e^{j2\pi i'm/L} \sum_{l=-\infty}^{\infty} h_{tot}[lL-i'] e^{-j2\pi n(lL-i')/N} \\
 &= N_1 \sum_{m=0}^{L-1} x_{mN_1+n} \sum_{i'=0}^{L-1} e^{j2\pi i'm/L} \frac{1}{LT_c} \sum_l \mathbf{H}_{tot}(\frac{2\pi n}{NT_c} - \frac{2\pi l}{LT_c}) e^{j2\pi l i'/L} \\
 &= \frac{N_1}{LT_c} \sum_{m=0}^{L-1} x_{mN_1+n} \sum_l \mathbf{H}_{tot}(\frac{2\pi n}{NT_c} - \frac{2\pi l}{LT_c}) \sum_{i'=0}^{L-1} e^{j2\pi(l+m)i'/L} \\
 &= \frac{N_1}{T_c} \sum_{m=0}^{L-1} x_{mN_1+n} \mathbf{H}_{tot}(\frac{2\pi n}{NT_c} + \frac{2\pi m}{LT_c}) \\
 &= \frac{N_1}{T_c} \sum_{m=0}^{L-1} x_{mN_1+n} \mathbf{H}_{tot}(\frac{2\pi}{NT_c}(mN_1+n)), \quad n = 0, \dots, N_1-1 \\
 &= N_1 \sum_{m=0}^{L-1} x_{mN_1+n} \mathbf{H}_{tot}[mN_1+n], \quad n = 0, \dots, N_1-1
 \end{aligned}$$

where

$$\mathbf{H}_{tot}[n] = \frac{1}{T_c} \mathbf{H}_{tot}(\frac{2\pi}{NT_c}n), \quad \text{for } 0 \leq n < N$$

**Relationship between  $q_n$  and  $x_n$**

As shown in Fig. 1G if  $H_{tot}[n]$  is a bandpass filter and nonzero only in the intervals  $[k(N/2L), (k+1)(N/2L)]$  and  $[(2L-k-1)(N/2L), (2L-k)(N/2L)]$ , where  $0 \leq k < L$ , the possible values of  $m$  that

5

$$H_{tot}[m(N/L) + n]$$

10 is nonzero for  $0 \leq n < (N/L)$  are as follows.

**Even  $k$**

If  $k$  is even, we can have  $m=k/2$  and  $0 \leq n < (N/2L)$  so that

15

$$H_{tot}[m(N/L) + n]$$

20

is nonzero over the interval  $[k(N/2L), (k+1)(N/2L)]$ , and  $m=(L-1)-k/2$  and  $(N/2L) \leq n < (N/L)$  so that

$$H_{tot}[m(N/L) + n]$$

25

is nonzero over the interval  $[(2L-k-1)(N/2L), (2L-k)(N/2L)]$ .

**Odd  $k$**

30 If  $k$  is odd, we can have  $m=(k-1)/2$  and  $(N/2L) \leq n < (N/L)$  so that

$$H_{tot}[m(N/L) + n]$$

35

is nonzero over the interval  $[k(N/2L), (k+1)(N/2L)]$ , and  $m=L-(k-1)/2$  and  $0 \leq n < (N/2L)$  so that

$$H_{tot}[m(N/L) + n]$$

40

is nonzero over the interval  $[(2L-k-1)(N/2L), (2L-k)(N/2L)]$ .

The above discussion is illustrated in Fig. 1G for  $L = 3$ .

45 In another variation that can be used in the present invention, similar advantages to those obtained by limiting bandwidth in the received signal in the downstream transceiver can be obtained by also optionally limiting the upstream data rate of the transceiver as well. In other words, the ADSL standard provides for 31 channels in the upstream direction, but many applications do not require this amount of bandwidth. The constraints, requirements and costs associated with the DMT modulation signal processing, and DAC 330 also can be significantly reduced by transmitting only a sub-set of the available 31 sub-channels. The determination of the appropriate sub-channels would be accomplished in essentially the same manner as set forth above, except that the information on upstream sub-channel SNR usually must be determined by the upstream transceiver, and then fed back to the downstream transceiver. To save time and overhead complexity, and given the fact that there is less variation in bit capacity in sub-channels in this frequency band, one approach also would be to simply select a fixed sub-set of such sub-channels-without regard to their actual performance characteristics. In a software modem environment, Control/Application software 500 would provide a user with selectable control to effectuate a restricted upstream transmission on limited sub-channels. Again, with respect to the ADSL standard, the only requirement in this respect is that the upstream pilot tone must also be transmitted to establish a valid data link. An optional limited "upstream" transmission can be effectuated in a variety of ways by the circuitry already described above in connection with Figs. 2 and 3. The exact details of such implementation will be appar-

ent to those of skill in the art given the present teachings.

Although the present invention has been described in terms of a preferred ADSL embodiment, it will be apparent to those skilled in the art that many alterations and modifications may be made to such embodiments without departing from the teachings of the present invention. For example, it is apparent that the present invention would be beneficial used in any xDSL or high speed multi-carrier application environment. Other types of VLSI and ULSI components beyond those illustrated in the foregoing detailed description can be used suitably with the present invention. Accordingly, it is intended that the all such alterations and modifications be included within the scope and spirit of the invention as defined by the following claims.

10 **Claims**

1. A high speed communications system capable of supporting a downstream data transmission from a upstream transceiver using a analog signal consisting of M data carrying signals contained within a bandwidth F, said system comprising:
  - 15 a channel interface circuit for coupling to and receiving said analog signal; and
  - a front end receiving circuit for processing the analog signal and converting it to a digital signal;
  - a processing circuit for extracting N data carrying signals ( $N < M$ ) from the digital signal using a first frequency portion f1 of the digital signal ( $f1 < F$ ).
- 20 2. The system of claim 1, wherein the N data carrying signals are selected by the processing circuit based so as to minimize the amount of processing required to extract the selected data from the digital signal.
3. The system of claim 2, wherein the N data carrying signals can be selected during a initialization process setting up a data link to the upstream transceiver.
4. The system of claim 3, wherein M data carrying signals can be sent by the upstream transmitter during a initialization process, and thereafter, only N data carrying signals are sent.
- 30 5. The system of claim 1, wherein the front end circuit includes: (i) a sub-band filter for passing the first frequency bandwidth portion f1 of said bandwidth F; (ii) and an analog to digital converter.
6. The system of claim 1, wherein the selected data further includes data obtained from an additional second frequency bandwidth portion f2 of said bandwidth F, so that an additional number of data carrying signals P from the M data carrying signals ( $N+P < M$ ) can be processed.
- 35 7. The system of claim 6, further including one or more sub-band filters for passing the first frequency bandwidth portion f1 and second frequency bandwidth portion f2 of said bandwidth F and an analog to digital converter.
- 40 8. The system of claim 7, wherein a target data rate of the system can be increased by processing an additional number of data carrying signals P from the M data carrying signals, where  $N+P < M$ .
9. The system of claim 1, wherein the selected data to be extracted from the bandpassed data can be controlled by a user of such system.
- 45 10. The system of claim 9, wherein a user of such system can increase a target data rate of the system by modularly augmenting the front end circuit to include additional bandwidth and analog to digital conversion capacity such that an additional number of data carrying signals P from the M data carrying signals ( $N+P < M$ ) can be processed.
- 50 11. The system of claim 1, further including a front end transmitting circuit for transmitting control information to cause said upstream transceiver to transmit downstream data only using the N data carrying signals.
12. The system of claim 11, wherein the control information transmitted to the upstream transceiver includes feedback information indicating that only N of the M data carrying signals are desirable for downstream data transmission, even during times when said channel is capable of supporting more than N data carrying signals.
- 55 13. The system of claim 12, wherein the control information transmitted to the upstream transceiver further includes feedback information indicating that: (i) the system can support any data protocols used by said upstream trans-

ceiver; and (ii) that they are connected through a channel with substantial signal attenuation characteristics for data signals other than the N data carrying signals.

- 5 14. The system of claim 1, further including a front end transmitting circuit for transmitting an upstream data signal using a second frequency bandwidth F2 different from F, and L data carrying signals, and where  $L < M$ .
- 15 15. A high speed communications system for processing an analog data signal from a channel capable of supporting M modulated sub-channels, said system comprising:
- 10 a channel interface circuit for coupling to and receiving said analog data signal from the channel;
- a analog front end circuit for processing the analog data signal and converting it to a digital signal;
- 15 a processing circuit for extracting data from the digital signal, the digital signal including data taken from a number N of said sub-channels, where N is intentionally selected to have a value less than M and where N is negotiated with an upstream transceiver during a initialization procedure.
16. The system of claim 15, where the N sub-channels are initially loaded with bit capacities that are left essentially unchanged unless said channel characteristics vary.
- 20 17. The system of claim 15, wherein the selection of the N sub-channels can be done during the initialization procedure.
18. The system of claim 15, wherein the value of N is based on signal processing capability of the processing circuit.
- 25 19. The system of claim 15, wherein a target data rate of the system can be increased by processing a additional number of sub-channels P from the M sub-channels, and where  $N+P < M$ .
- 30 20. The system of claim 15 further including a front end transmitting circuit for transmitting control information to cause said upstream diver to transmit downstream data only using the N sub-channels.
- 35 21. The system of claim 15, wherein the upstream transceiver uses discrete multi-tone (DMT) modulation for generating the M modulated sub-channels, and the channel supports asymmetric digital subscriber loop (ADSL) transmission standards.
- 40 22. A high speed communications system for processing an analog data signal from a channel capable of supporting M modulated sub-channels, said system comprising:
- a channel interface circuit for coupling to and receiving said analog data signal from the channel;
- 45 an analog front end circuit for processing the analog data signal and converting it to a digital signal;
- a bus interface circuit for transmitting the digital signal to a host processing device, and for receiving a transmission control signal from the host processing device to cause said upstream transmitter to transmit using only from a number N of said sub-channels, where N is intentionally selected to have a value less than M, and where N is negotiated with a upstream transceiver during a initialization procedure.
- 50 23. The system of claim 22, wherein the value of N is based on signal processing capability of the host processing device.
- 55 24. The system of claim 22, wherein a data rate of the system can be increased by processing an additional number of sub-channels P from the M sub-channels, and where  $N+P < M$ .
25. The system of claim 22, wherein the upstream transceiver uses discrete multi-tone (DMT) modulation for generating the M modulated sub-channels, and the channel supports asymmetric digital subscriber loop (ADSL) transmission standards.
26. A method of processing a xDSL signal from a digital subscriber loop, said method including the steps of:



negotiating a reduced data rate R' for said signal between a downstream and a upstream transceiver; and

thereafter transmitting said xDSL signal from the upstream transceiver to the downstream transceiver utilizing a number of sub-channels N to effectuate the reduced data rate R', where N is intentionally selected to be less than a maximum number of sub-channels M supported by said digital subscriber loop; wherein the number of sub-channels N is based on signal processing capability available to the downstream transceiver.

27. The method of claim 26, wherein the data rate of the system can be increased by processing an additional number of sub-channels P from the M sub-channels, and where  $N+P < M$ .

28. The method of claim 26, wherein the upstream transceiver uses discrete multi-tone (DMT) modulation for generating the M sub-channels.

29. The method of claim 26, wherein the reduced data rate R' can be specified by a user operating the downstream transceiver.

30. A high speed communications data receiver for communicating through a channel at a data rate X with an upstream transmitter capable of transmitting a data stream at a rate Y ( $X < Y$ ), the receiver comprising:

a channel interface circuit for coupling to and receiving said data stream; and  
 an analog front end circuit for data sampling the analog signal and converting it to a digital signal; and  
 a processing circuit for extracting selected data from the digital signal, and for generating a transmission control signal for causing said upstream transmitter to transmit at a data rate substantially equal to said data rate X during a data stream transmission; and  
 wherein data sampling requirements of the analog front end circuit and extracting of the processing circuit are reduced because data sampling and extracting is only performed for a fractional portion of the data stream.

31. The system of claim 30, wherein the analog front end circuit further includes one or more sub-band filters for filtering the analog data signal to generate the fractional portion of the data stream that requires data sampling and extracting.

32. The system of claim 30, further including a front end transmitting circuit for transmitting the transmission control signal from the processing circuit to cause said upstream transceiver to transmit downstream data only at said data rate X.

33. The system of claim 32, wherein the control information transmitted to the upstream transceiver includes feedback information indicating that the maximum downstream data transmission data rate is X, even during times when said channel is capable of supporting more than said data rate X.

34. The system of claim 30, further including a front end transmitting circuit for transmitting an upstream data transmission using a data rate Z, where  $Z < Y$ .

35. The system of claim 30, wherein the ratio of X to Y is approximately .5 or less, and this ratio can be increased through modular additions to the analog front end circuit.

36. A high speed communications data receiver for communicating through a channel with an upstream transmitter that is capable of transmitting a data signal with a particular frame rate T and data rate Y, the receiver comprising:

a channel interface circuit for coupling to and receiving said data signal; and  
 an analog front end circuit for sampling the data signal and converting it to a digital signal; and  
 a processing circuit that: (i) is configurable for processing the digital signal at a data rate  $\leq X$  and using said frame rate T, where X is determined for such processing circuit prior to initialization of a data transmission and  $X < Y/2$ ; (ii) generates a transmission control signal for causing said upstream transmitter to transmit at a data rate no greater than X during a data transmission;  
 wherein signal processing requirements for the processing circuit are reduced because processing is only performed at a fractional rate of the available data rate of said transmission protocol.

37. The system of claim 36, wherein the control information transmitted to the upstream transceiver includes feedback information indicating that the maximum downstream data transmission data rate is X, even during times when said channel is capable of supporting more than said data rate X.
- 5 38. The system of claim 36, wherein the feedback information including the data rate X can be controlled by a user of such system.
39. The system of claim 36, wherein the ratio of X to Y is approximately .2 or less.
- 10 40. A high speed communications system for transmitting digital information in a channel capable of supporting a transmission bandwidth F, said system comprising:
- an upstream data transceiver capable of modulating the digital information to generate an analog data signal data transmission using said transmission bandwidth F; and
- 15 a downstream data transceiver channel interface circuit for coupling to and receiving said analog data signal from the upstream data transceiver through said channel, the downstream data transceiver including:
- (i) a front end receiving circuit for processing the analog data signal and converting it to a digital signal; and
- 20 (ii) a processing circuit for demodulating the digital signal, the digital signal including data from a first frequency bandwidth portion f1 of said bandwidth and for generating feedback information indicating to the upstream transceiver that the bandwidth other than f1 is unsuitable for data transmission; and
- (iii) a front end transmitting circuit for transmitting the feedback information using a second frequency bandwidth portion f2 to cause said upstream transceiver to transmit downstream data only using the first frequency portion f1.
- 25 41. The system of claim 40, wherein the ratio of f1 to F is approximately .5 or less, and this ratio can be increased through modular additions to the front end receiving circuit.
42. The system of claim 40, wherein the feedback information contains intentionally altered channel characteristic information.
- 30 43. The system of claim 41, wherein the feedback information, including the size and location of first frequency portion f1, can be controlled by a user of such system.
- 35 44. A high speed communications data receiver for communicating through a channel at a controllable data rate X with an upstream transmitter capable of transmitting a data signal at a frame rate T, and a data rate Y, where  $X/Y < 1/2$ , the receiver comprising:
- a channel interface circuit for coupling to and receiving said analog data signal; and
- 40 an analog front end circuit for data sampling the analog signal and converting it to a digital signal; and
- a processing circuit for determining said rate X based on processing capabilities available for extracting data from the digital signal, and for generating a transmission control signal for causing said upstream transmitter to transmit using said frame rate T, and a data rate substantially equal to said data rate X during a data transmission.
- 45 45. The receiver of claim 44, wherein said rate X is determined during a calibration routine.
46. The receiver of claim 45, wherein said calibration routine is executed by a host data processor to determine the capabilities of such processor.
- 50 47. The receiver of claim 44, wherein said rate X is configurable by a user of such receiver based on performance characteristics of a host processor comprising a portion of the processing circuit.
48. The receiver of claim 44, wherein  $X/Y$  is approximately .5 or less.
- 55 49. A method for communicating through a channel with an upstream transmitter that is capable of transmitting a data signal at a frame rate T, and a data rate Y, the method comprising the steps of:

- receiving said data signal; and  
 sampling the data signal and converting it to a digital signal; and  
 processing the digital signal at a data rate  $\leq X$  and using said frame rate T, where X is determined prior to initialization of a data transmission and  $X < Y/2$ ; and  
 5 generating a transmission control signal for causing said upstream transmitter to transmit at a data rate no greater than X during a data transmission.
50. The method of claim 49, wherein the control information transmitted to the upstream transceiver includes feedback information indicating that the maximum downstream data transmission data rate is X, even during times when said  
 10 channel is capable of supporting more than said data rate X.
51. The method of claim 49, wherein the feedback information including the data rate X can be controlled by a user of such system.
- 15 52. The method of claim 49, wherein said rate X is determined during a calibration routine.
53. The method of claim 49, wherein said rate X is configurable by a user of such receiver based on performance characteristics of a host processor comprising a portion of the processing circuit.
- 20 54. A method of operating a high speed communications system that is coupled through a channel to an upstream transceiver operating at a maximum data rate Y using a bandwidth F, said method comprising:
- (a) receiving an analog initialization signal having a bandwidth F from the upstream transceiver through the channel; and  
 25 (b) generating a digital signal based on sampling a portion of the analog data transmission signal corresponding to a first frequency bandwidth portion f1, where  $f1 < F$ ; and  
 (c) processing the digital signal to extract data from the digital signal such that an effective receiving rate X (where  $X < Y$ ) is achieved by the system;  
 (d) generating feedback information pertaining to the channel transmission characteristics indicating to the  
 30 upstream transceiver that data rates higher than X should not be used;  
 (e) thereafter receiving an analog data signal transmitted by the upstream transceiver to have a bandwidth f1;  
 (f) repeating steps (b) and (c).
55. The method of claim 54, further including a step prior to step (a): receiving a control signal from a user of such system for determining the effective receiving rate X.
- 35 56. The method of claim 54, further including a step: determining an optimal bandwidth portion f1 so as to minimize the amount of processing required to extract the data from the digital signal at the receiving rate X.
- 40 57. A high speed communications transceiver for communicating with an upstream transceiver transmitting an analog data transmission signal using M data carrying signals within a bandwidth F through a channel to said system, said transceiver comprising:
- a channel interface circuit for coupling to and receiving said analog data signal from the channel; and  
 45 a front end receiving circuit for sampling the analog data signal and generating a digital signal based on such analog data signal, the digital signal including data from a first frequency bandwidth portion f1 of said bandwidth F containing N data carrying signals, where  $N < M$ ; and  
 a bus interface circuit for transmitting the digital signal to a host processing device; and  
 wherein the system's performance, including data rate, can be scaled based on modifications to said front end  
 50 receiving circuit or said host processing device so that a the sampling of the analog data signal can be increased, and the first frequency bandwidth portion f1 can also be expanded.
58. The system of claim 57, wherein the front end receiving circuit includes a filter for passing the first frequency bandwidth portion f1 of said bandwidth F; (ii) and an analog to digital converter.
- 55 59. The system of claim 58, wherein when the modifications include additional bandpass filters for increasing the first frequency bandwidth portion from f1 to f2, where  $F > f2 > f1$ , the number of data carrying signals is increased from N to N+P, where  $P = f2/f1 * N$ , and  $N+P < M$ .

60. The system of claim 57, wherein the modifications include adding an additional number of front end circuits  $k$  in the system each with a bandpass frequency  $f_1$  to result in  $N \cdot k$  data carrying signals being included within the digital signal.
- 5 61. The system of claim 57, wherein the first frequency bandwidth portion  $f_1$  is programmable.
62. The system of claim 57, further including a front end transmitting circuit for transmitting control information to cause said upstream transceiver to transmit downstream data only using the  $N$  data carrying signals.
- 10 63. The system of claim 62, wherein the control information transmitted to the upstream transceiver includes feedback information from the host processing device indicating to the upstream transceiver that only  $N$  of the  $M$  data carrying signals are desirable for downstream data transmission, even if said channel is capable of supporting more than  $N$  data carrying signals.
- 15 64. The system of claim 63, wherein the front end transmitting circuit transmits an upstream data transmission using a second frequency bandwidth  $F_2$  and  $L$  upstream data carrying signals, and where  $L < M$ .
65. The system of claim 57, further including a host processor circuit in the host processing device for extracting selected data from the  $N$  data carrying signals.
- 20 66. The system of claim 65, wherein host processor circuit includes a host microprocessor, a programmable memory coupled to the microprocessor, and a data extraction routine located in the memory which can be executed by the microprocessor.
- 25 67. The system of claim 66, wherein the modifications include upgrading said host processing circuit to include additional signal processing power for processing an additional number of data carrying signals.
68. A method of operating a high speed interface between an upstream transceiver and a host processing device at a target data rate, said method comprising:
- 30 (a) receiving an analog initialization signal having a bandwidth  $F$  from the upstream transceiver through a communications channel; and  
(b) generating a digital signal based on sampling a portion of the analog initialization signal corresponding to a first frequency bandpass portion  $f_1$ ;
- 35 (c) transmitting the digital signal to said host processing device so that characteristics of data carrying signals contained within first frequency bandpass portion  $f_1$  can be determined, and a number of such data carrying signals can be configured for use by said host processing device to achieve said target data rate; and  
(e) generating feedback information indicating to the upstream transceiver that bandwidth other than the first frequency bandpass  $f_1$  should not be used for data transmission; and
- 40 (f) receiving an analog data transmission signal having a bandwidth  $f_1$  from said upstream transceiver; and  
(g) generating a digital signal based on sampling the analog data transmission signal; and  
(h) transmitting the digital signal to the host processing device so that it can be processed to extract selected data from the data carrying signals;
- 45 (i) when a data rate increase is required, expanding the first frequency bandpass portion  $f_1$  and returning to step (a).
69. The method of claim 68, further including a step of: determining an optimal size and location of first frequency bandpass portion  $f_1$  so as to minimize the amount of processing required by said host processing device to extract the data from the digital signal.
- 50 70. The method of claim 68, wherein the ratio of  $f_1$  to  $F$  is approximately .5 or less, and a data rate of such interface is controlled by controlling this ratio.
71. The method of claim 68 wherein the analog data transmission is comprised of  $M$  modulated sub-channels within bandwidth  $F$ , and the selected data is contained in  $N$  of the  $M$  sub-channels within first selected frequency bandpass portion  $f_1$ , where  $N < M$ .
- 55 72. The method of claim 68, further including a step: determining an optimal set of  $N$  sub-channels so as to minimize

**EP 0 889 615 A2**

the amount of processing required to extract the data from the digital signal.

5 73. The method of claim 68, further including a step wherein protocol information pertaining to standards applicable to Asymmetric Digital Subscriber Loops is transmitted by the upstream data transceiver so as to set up a ADSL compatible data link.

10 74. The method of claim 68, wherein during step (i) the first frequency bandpass portion  $f_1$  is increased by the use of additional bandpass filters for increasing the first frequency bandwidth portion from  $f_1$  to  $f_2$ , where  $F > f_2 > f_1$ , so that the selected data is received at an increased rate equal to approximately  $f_2/f_1$ .

15

20

25

30

35

40

45

50

55

**FIGURE 1**

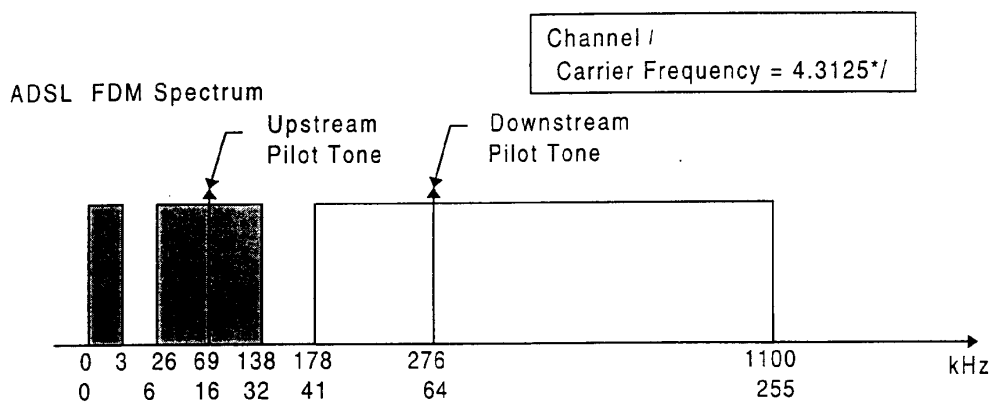

**FIGURE 1B**

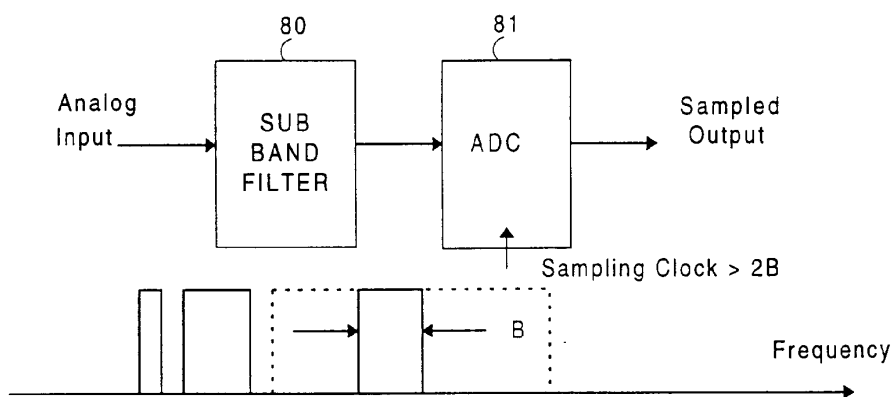

**FIGURE 1C**

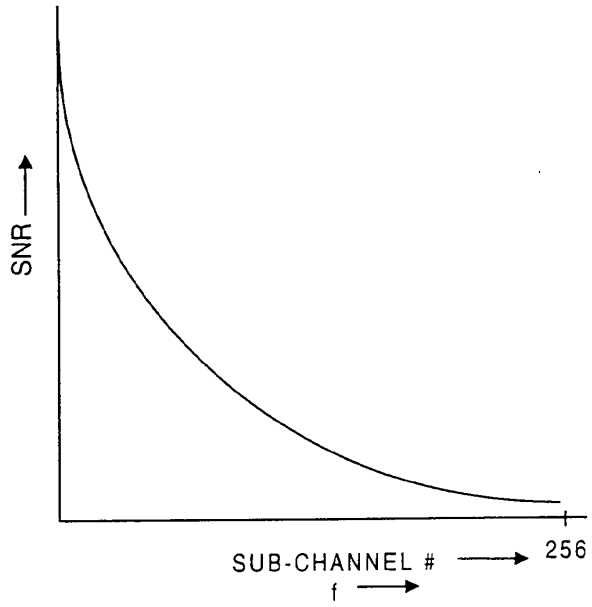

**FIGURE 1D**

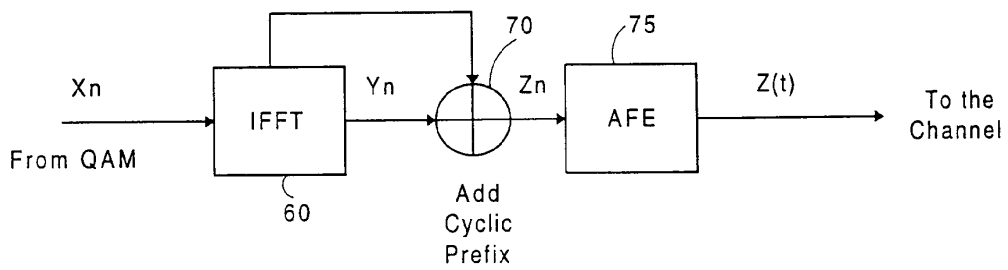

**FIGURE 1E**

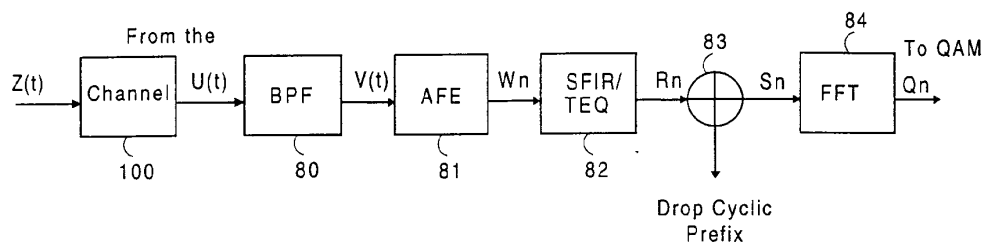

**FIGURE 1F**

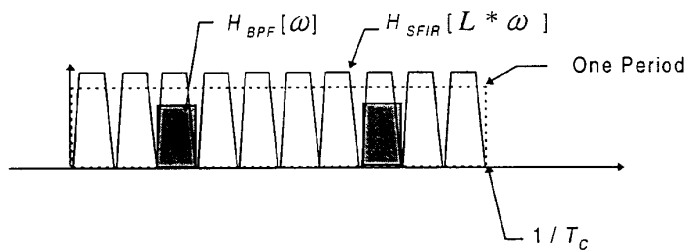



**FIGURE 1G**

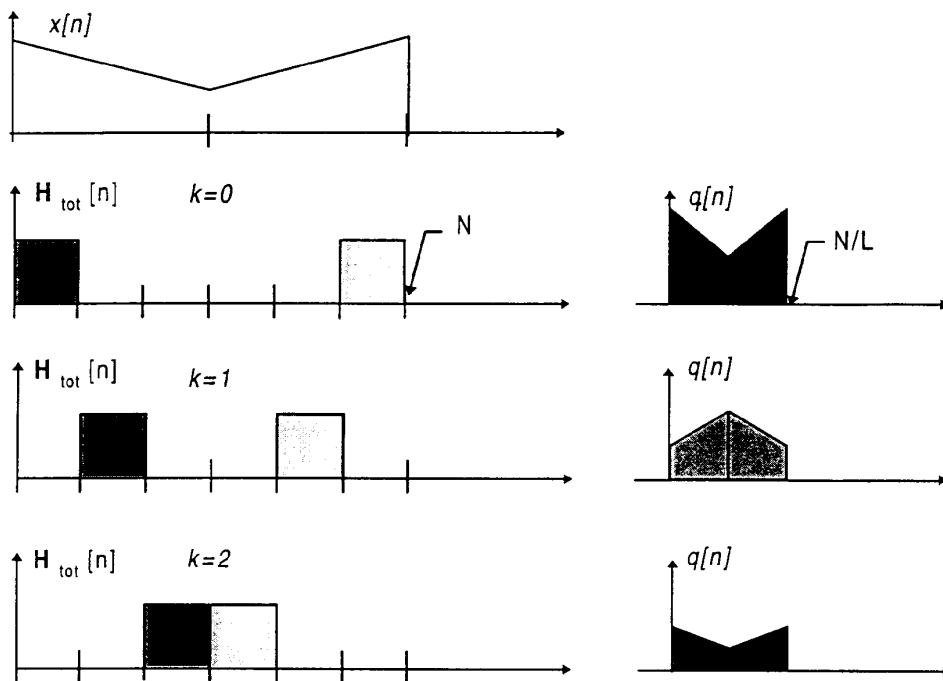

FIGURE 2

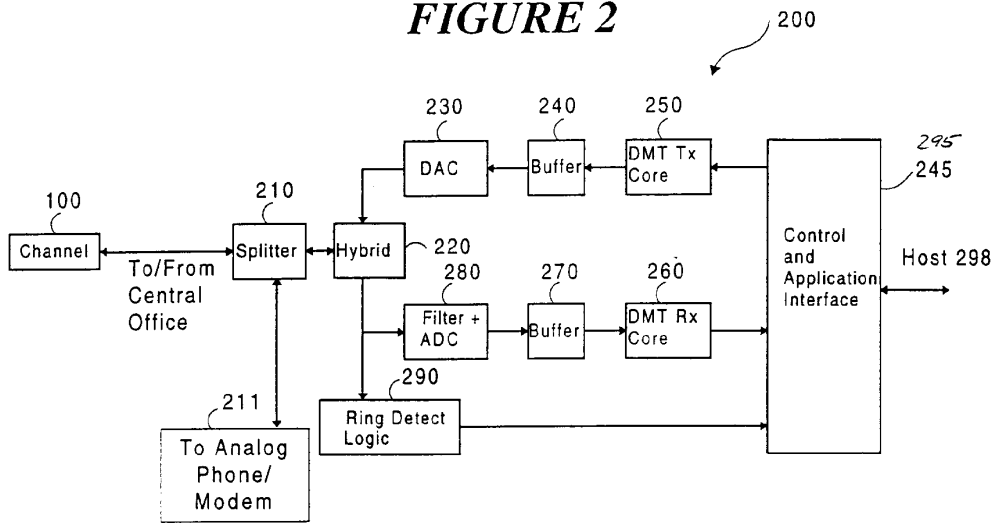

FIGURE 3A

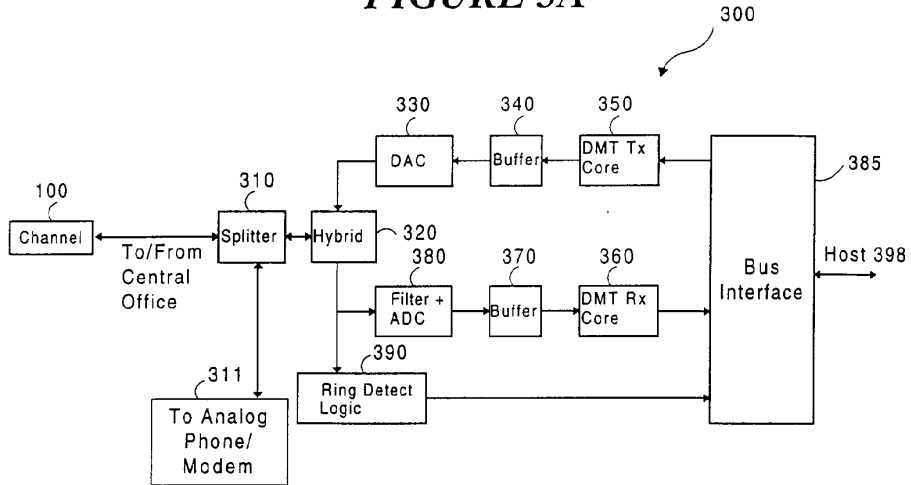

FIGURE 3B

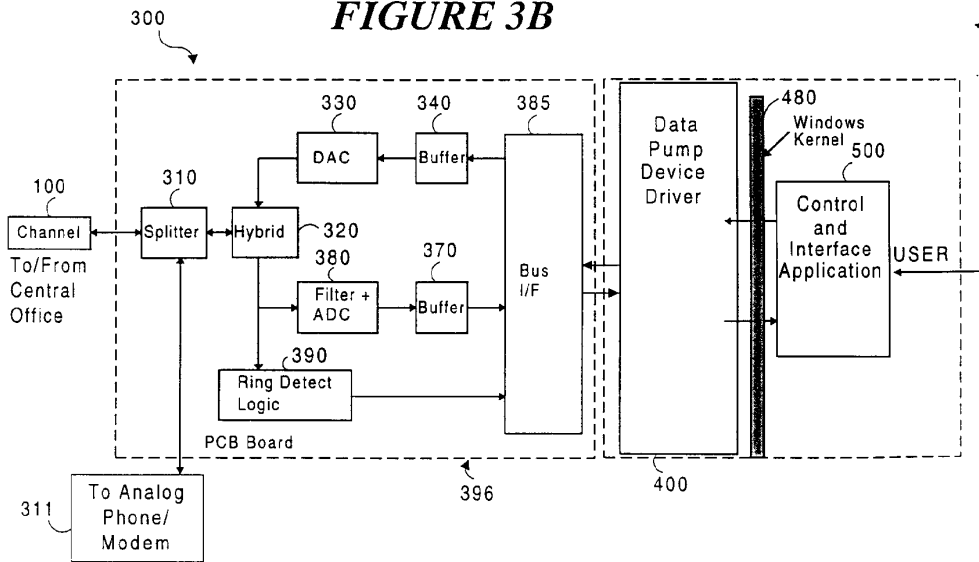
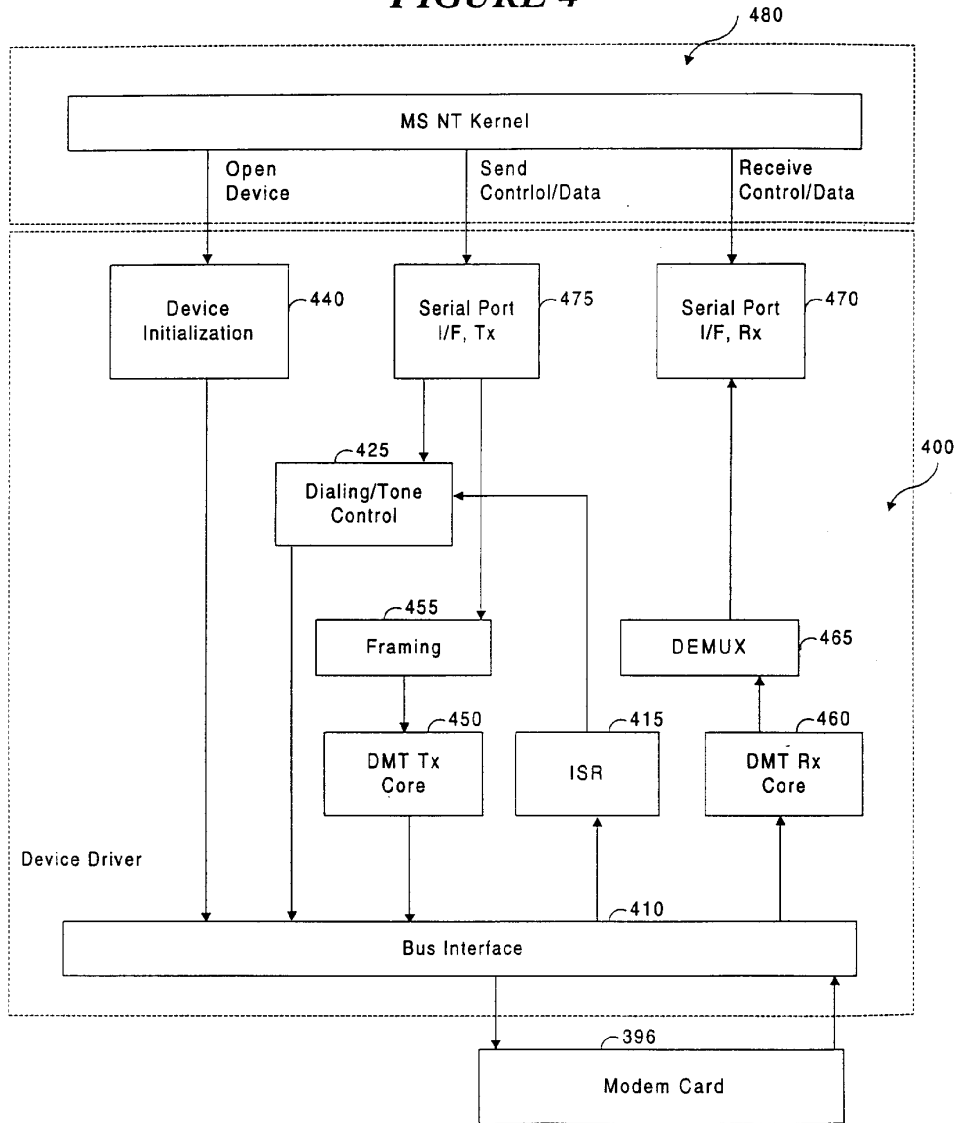

FIGURE 4



**FIGURE 5**

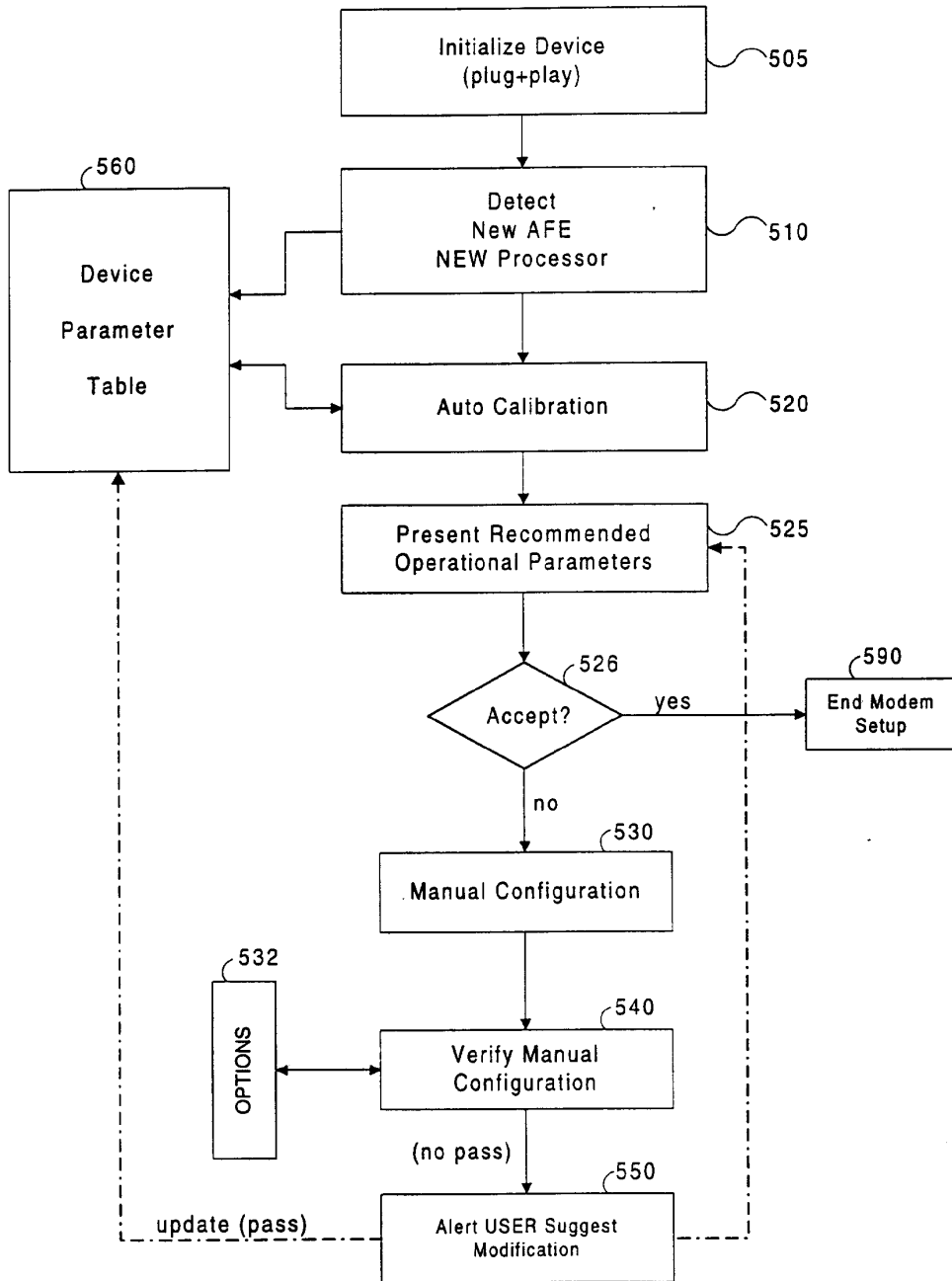
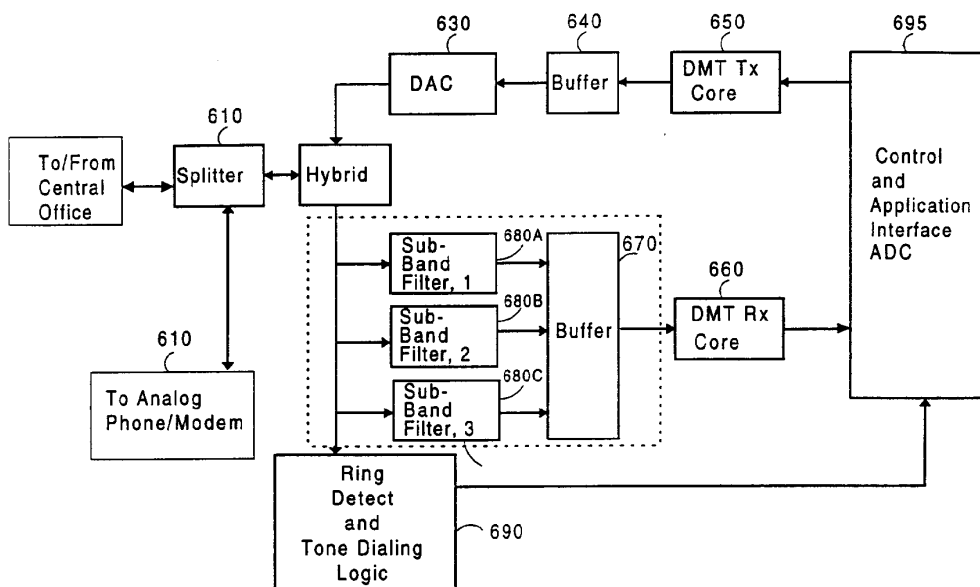

FIGURE 6



(12) UK Patent Application (19) GB (11) 2 303 032 (13) A

(43) Date of A Publication 05.02.1997

(21) Application No 9613602.3

(22) Date of Filing 28.06.1996

(30) Priority Data

(31) 95019065 (32) 30.06.1995 (33) KR

(71) Applicant(s)

Samsung Electronics Co Limited

(Incorporated in the Republic of Korea)

416 Maetan-dong, Paldal-gu, Suwon-City, Kyungki-do,  
Republic of Korea

(72) Inventor(s)

You-sik Chun

(74) Agent and/or Address for Service

Elkington and Fife  
Prospect House, 8 Pembroke Road, SEVENOAKS,  
Kent, TN13 1XR, United Kingdom

(51) INT CL<sup>6</sup>  
H04L 5/06

(52) UK CL (Edition O )  
H4P PAQ

(56) Documents Cited  
None

(58) Field of Search  
UK CL (Edition O ) H4P PAL PAQ PEM  
INT CL<sup>6</sup> H04L 5/06 27/34  
ONLINE:WPI

(54) Adaptive bit swapping between channels of a discrete multitone system

(57) An adaptive bit swapping method and device are provided. The method includes the steps of (a) initializing (200) the DMT system to transmit the data via the channel in a steady state; (b) selecting (204) a frame (400) having an inserted sync block from a frame structure of the transmitted data; (c) calculating (210) the signal-to-noise ratios (SNRs) of respective sub-channels of the selected frame; (d) calculating (214) a first difference value between the present representative SNRs calculated in step (c) and the previous representative SNRs of each sub-channel; (e) selecting (216) a maximum value and minimum value among the first difference values of the respective sub-channels; (f) obtaining a second difference value being a difference between the maximum value and the minimum value; (g) determining (218) whether the second difference value is equal to or greater than the predetermined threshold value; and (h) correcting (220) bit and power assigning tables of a transmitter and a receiver if the second difference value is greater than or equal to the threshold value. In addition, the bit and power assigning tables can be corrected accurately since bits and power are swapped using an actually measured SNR.

FIG. 3

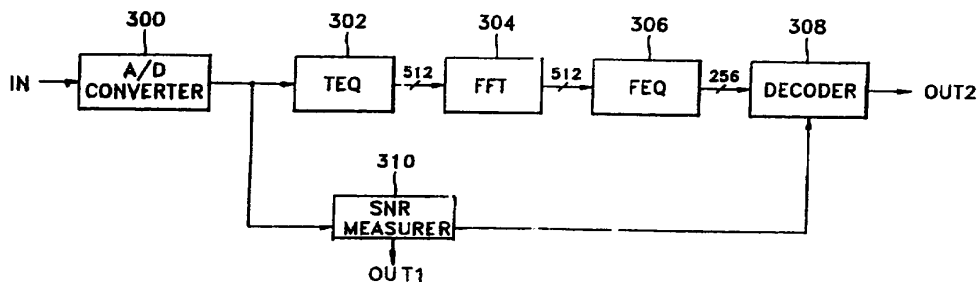

GB 2 303 032 A

FIG. 1 (PRIOR ART)

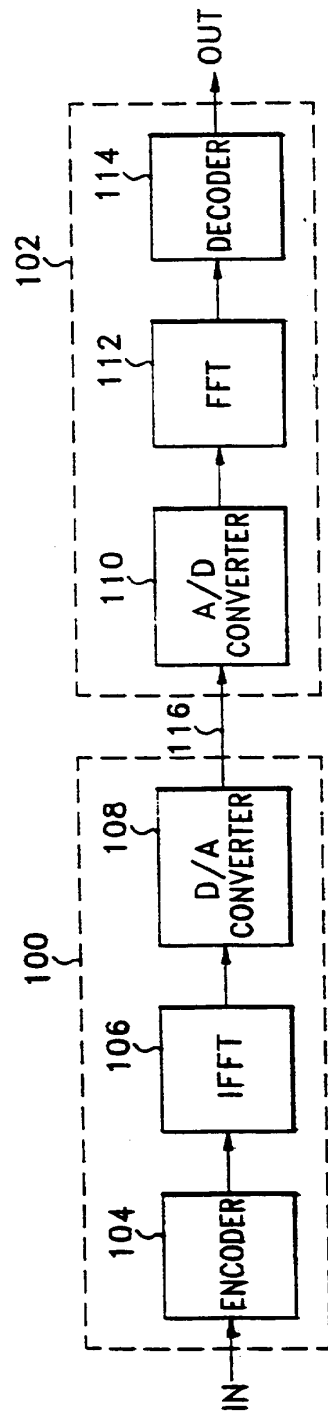



FIG. 2

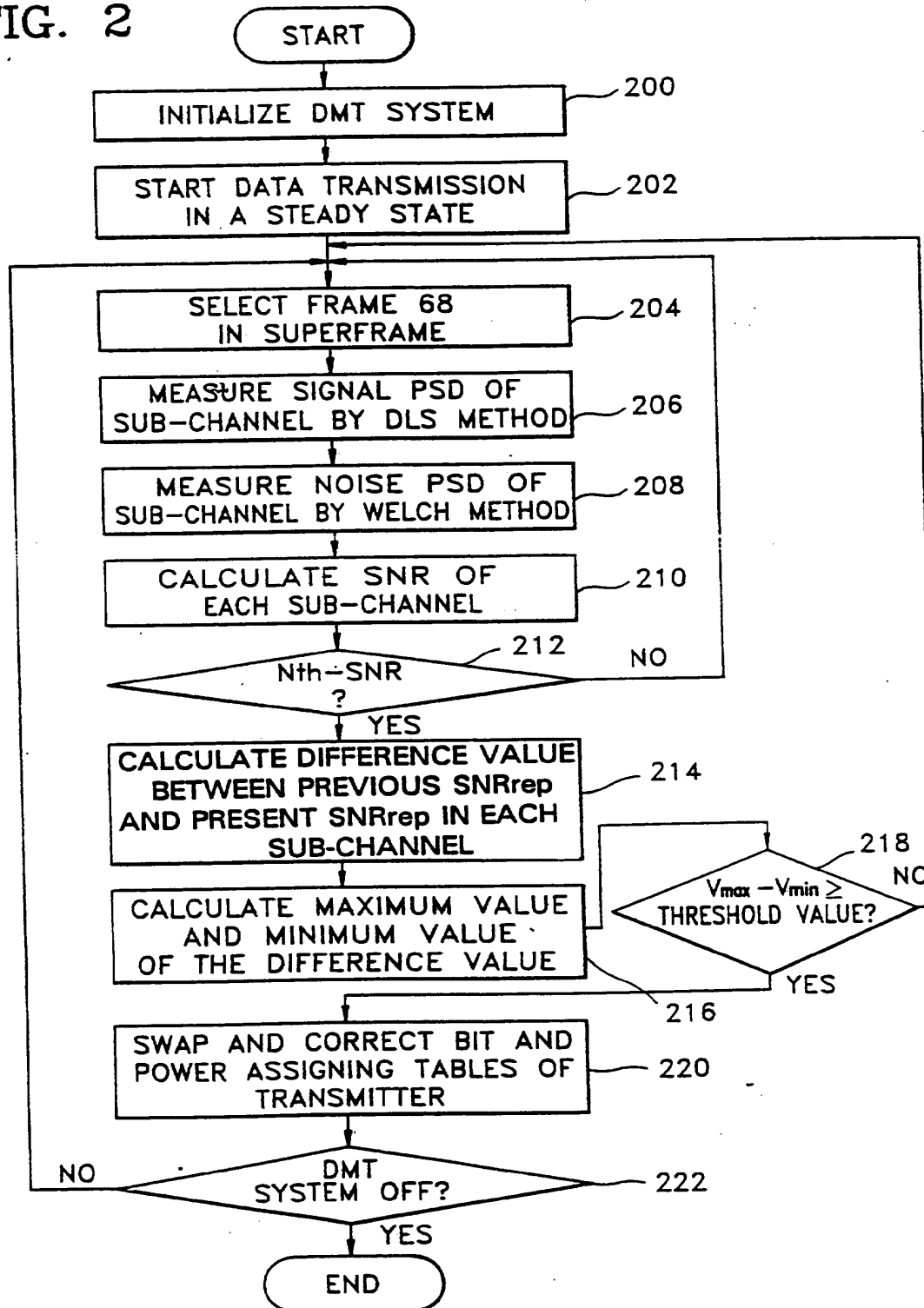

FIG. 3

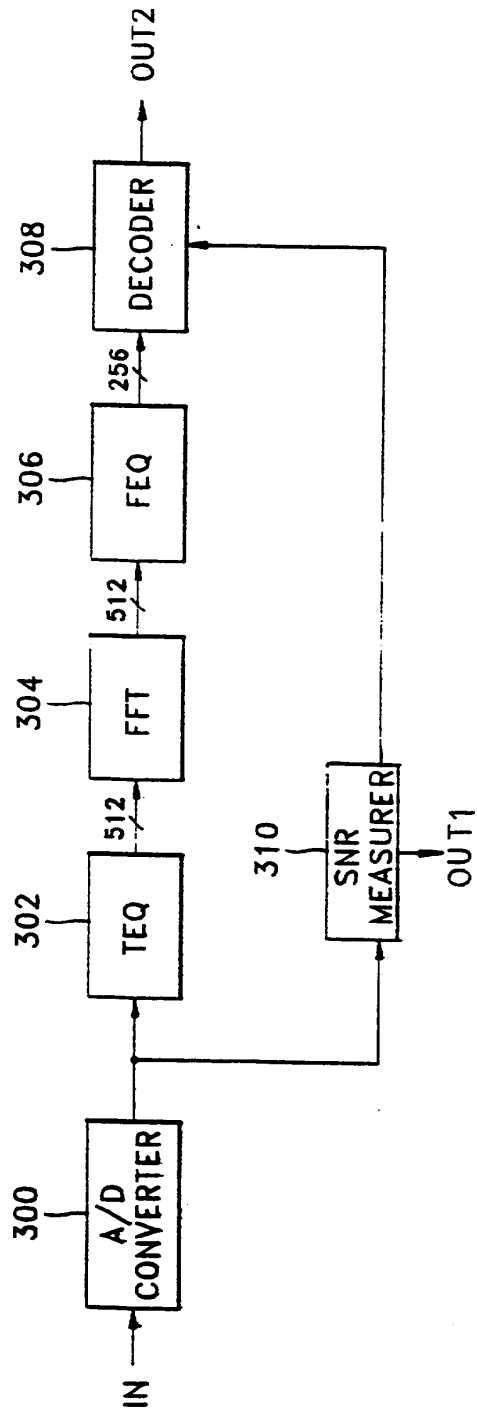
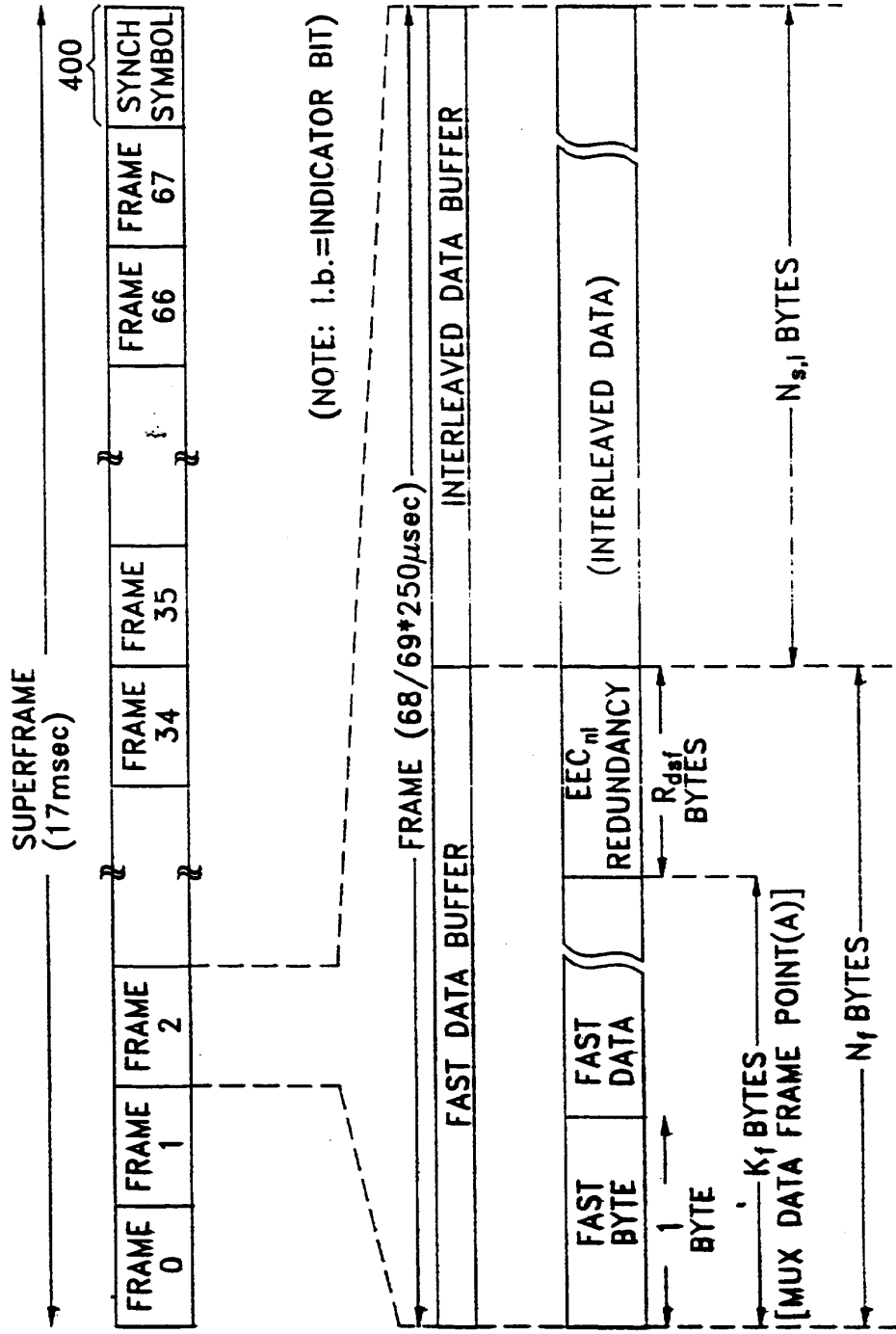

FIG. 4



**ADAPTIVE BIT SWAPPING METHOD AND DEVICE  
FOR DISCRETE MULTITONE SYSTEM**

The present invention relates to a discrete multitone (DMT) system, and more particularly, to an adaptive bit swapping method and device for a DMT system, which adjust  
5 the number of bits and power assigned to each sub-channel according to channel characteristics varied during data transmission.

A multicarrier is generally used in a DMT system to use a channel efficiently for transmitting data. Basically  
10 in multicarrier modulation, several carrier-modulated waveforms are overlapped to represent an input bit stream. A multicarrier transmission signal is the composite of M independent sub-signals or sub-channels, each having the same bandwidth of 4.3125KHz and respective main frequencies  
15 of  $f_i$  ( $i=1, 2, 3, \dots, M$ ). These sub-signals are Quadrature Amplitude Modulation (QAM) signals. When data is transmitted at a high speed via an inferior transmission path such as a copper line, the DMT system enables the data  
20 to be transmitted at 6Mbps or above, thus offering a good service. In this DMT system using several carriers, the number of bits and power of each channel depending on its signal-to-noise ratio (SNR) are assigned to each sub-channel in the initialization of the system.

25 Changing the number of bits and power assigned to each sub-channel according to its SNR, which is varied without an interruption in a data stream in a data transmission mode, is referred to as bit swapping. Bit swapping is used

in an Asymmetric Digital Subscriber Line (ADSL) service employing the DMT system to reduce an error probability of transmission data.

5 Channel characteristics vary gradually with time in most systems, and frequency response characteristics of an ADSL loop vary gradually with temperature. Therefore, a channel model determined in the initialization of a system should be changed according to the frequency response characteristics.

10 A conventional method for allocating bits to a sub-channel will be described as follows.

A transmitter terminal as well as a receiver terminal by adaption can operate according to the essential concept of a bit allocating method which has been proposed in a dissertation submitted to the Department of Electrical Engineering and the Committee on Graduate Studies of STANFORD University in partial fulfillment of the requirements for the Degree of Doctor of Philosophy, May 15 1993, entitled "BANDWIDTH OPTIMIZED DIGITAL TRANSMISSION TECHNIQUES FOR SPECTRALLY SHAPED CHANNELS WITH IMPULSE NOISE", by Ronald R. Hunt and P.S. Chow. Details of the bit allocating method there described are as follows:

- 25 1. the steady state mean square errors (MSE)'s of all used sub-channels are monitored, where these error values are differences between inputs and outputs of a slicer;
2. it is determined continuously whether the difference between a maximum error value and a minimum error value is a predetermined threshold value (generally

3dB) or above, and if the difference is the threshold value or above, the procedure goes to the subsequent step;

3. the bit number of a value in a bit allocation table for a sub-channel having the maximum error value is decreased by 1, while the bit number of a value in a bit allocation table for a sub-channel having the minimum error value is increased by 1;

4. the minimum error is doubled, while the maximum error is halved;

5. the slicer settings for two sub-channels whose bit values are changed are adjusted; and

6. the bit swapping information is sent back to a transmission part.

The initial number of bits allocated to a sub-channel is determined according to an SNR measured during an initialization in an ADSL DMT system. However, the above bit allocation method exhibits the drawback that an incorrect bit swapping may be performed, since an MSE value may be increased due to an error, such as a burst error when data is examined in a reception part, or a frequency-domain equalizer (FEQ) error which can affect MSE in a steady state.

To circumvent the above problems, it is first object of the present invention to provide an adaptive bit swapping method for a DMT system in which bits allocated to each sub-channel are swapped in a transmission unit according to an actually measured SNR.

It is second object of the present invention to

provide an adaptive bit swapping device for a DMT system.

To achieve the first object, there is provided an adaptive bit swapping method in a discrete multitone (DMT) system for an asymmetric digital subscriber line (ADSL) which has a transmitter for encoding and converting data to be transmitted via a channel, and a receiver for restoring the transmitted data to the original form by conversion and decoding, said method comprising the steps of: (a) initializing said DMT system to transmit said data via said channel in a steady state; (b) selecting a frame having an inserted sync block from a frame structure of said transmitted data; (c) calculating the signal-to-noise ratios (SNRs) of respective sub-channels of said selected frame; (d) calculating first difference value between the present representative SNRs calculated in step (c) and the previous representative SNRs of each sub-channel; (e) selecting a maximum value and minimum value among the first difference values of said respective sub-channels; (f) obtaining the second difference value between said maximum value and said minimum value; (g) determining whether said second difference value is equal to or greater than the predetermined threshold value; and (h) correcting bit and power assigning tables of a transmitter and a receiver if said second difference value is greater than or equal to said threshold value.

To achieve the second object, there is provided an adaptive bit swapping device functioning as a receiver for restoring the transmitted data to the original form by

conversion and decoding, said device being included in a discrete multitone (DMT) system for an asymmetric digital subscriber line (ADSL) which has a transmitter for encoding and converting data to be transmitted via a channel, said  
5 device comprising: A/D converting means for converting said analogue data signal received via said channel into a digital signal; time-domain equalizing means for receiving said digital signal and reducing a guard band used to remove an interblock interference; fast-Fourier  
10 transforming means for receiving the output of said time-domain equalizing means and demodulating said data signal modulated in said transmitter; frequency-domain equalizing means for receiving the output of said fast Fourier transforming means and compensating for a phase error of  
15 each sub-channel; SNR measuring means for selecting a frame having an inserted sync block from a frame structure of said transmitted data, calculating the signal-to-noise ratios (SNRs) of respective sub-channels of said selected frame, calculating first difference value between the  
20 present representative SNRs calculated above and the previous representative SNRs of each sub-channel, selecting a maximum value and minimum value among the first difference values of said respective sub-channels, obtaining the second difference value between said maximum  
25 value and said minimum value, determining whether said second difference value is equal to or greater than the predetermined threshold value and outputting to a transmitter and a receiver the signal used for correcting



bit and power assigning tables of a transmitter and a receiver; and decoding means for receiving the outputs of said SNR measuring means and said frequency-domain equalizing means, resetting a slice value, and decoding said reset slice value.

5

Specific embodiments of the present invention are described in detail below, by way of example, with reference to the attached drawings, in which:

FIG. 1 is a block diagram of a conventional basic DMT system;

10

FIG. 2 is a flow-chart of a bit swapping method for a DMT system according to an embodiment of the present invention;

FIG. 3 is a block diagram of a receiving unit in a DMT system for performing the method of FIG. 2 according to an embodiment of the present invention; and

15

FIG. 4 illustrates the structure of a superframe based on "ADSL standards", which is transmitted in a steady state.

20

An adaptive bit swapping method and device for a DMT system according to an embodiment of the present invention will be described below, with reference to the attached drawings.

25

A conventional basic DMT system shown in FIG. 1 has a transmitter 100 including an encoder 104, an inverse fast Fourier transformer (IFFT) 106 and a digital/analogue (D/A) converter 108, a receiver 102 including an analogue/digital (A/D) converter 110, a fast Fourier transformer (FFT) 112

and a decoder 114, and a transmission path (a transmission channel or a channel) 116. A DMT system for an ADSL transmits a signal via 256 individual channels each having a 4KHz bandwidth. The encoder 104 of the transmitter 100 in the DMT system shown in FIG. 1 simply receives data sequences via an input terminal IN (the accurate number of bits depends on a data rate and an overhead) and allocates the input data sequences to a multitude of sub-channels. The IFFT 106 produces a plurality of time based samples having several real number values from an encoded value. The D/A converter 108 converts a plurality of the received time based samples into an analogue signal suitable for transmission via a copper line, and transmits the analogue signal to the A/D converter 110 via the transmission path 116.

The receiver 102 performs the operations of the transmitter 100 in a reverse order. The receiver 102 consists of three components for performing time recovery, filtering, and channel check functions, respectively.

An adaptive bit swapping device for a DMT system according to an embodiment of the present invention is shown in Fig.3 and includes an A/D converter 300, a time-domain equalizer (TEQ) 302, an FFT 304, a frequency-domain equalizer (FEQ) 306, a decoder 308, and an SNR measurer 310.

Referring to FIG. 2, showing an algorithm for a bit swapping method for a DMT system according to an embodiment of the present invention, when the DMT system is activated

to transmit data, it is initialized with regard to the channel conditions of the transmitter and receiver, in step 200. The initialization is divided into activation & recognition, transceiver training, and channel analysis & exchange. The initialization in the embodiment of the present invention is especially concerned with channel analysis, since the SNR of each sub-channel of a channel formed between the transmitter and the receiver is measured and the number of bits and power are assigned according to the variation in the measured SNR. When the DMT system is placed in a steady state after the initialization, data transmission begins, in step 202.

FIG. 4 illustrates the structure of a superframe of data transmitted in a steady state, which is determined by "ADSL standards". Referring to FIG. 4, a sync(ronization) symbol 400 used to restore the synchronization of the data without reinitialization when the data are affected by an instantaneous interrupt is inserted in a frame 68 of frames 0-68.

In step 204, frame 68 alone is selected after step 202 in the embodiment of the present invention, whereas all frames among the 68 frames shown in FIG. 4 are selected to obtain MSEs in the prior art. In step 206, the signal PSD of each sub-channel is measured by a deterministic least sequence (DLS) method, after step 204. The DLS method indicates that known sequence values received from the transmitter via the channel are accumulated and averaged. A channel response free of random noise can be achieved by

this method, and the signal PSD of each sub-channel can be achieved by fast Fourier transforming the channel response. In step 208, the noise PSD of each sub-channel is measured by a Welch method after step 206. After step 208, the SNR of each sub-channel is obtained from the measured signal PSD and noise PSD in step 210. After step 210, it is determined whether the obtained SNR is the Nth SNR of each sub-channel or not in step 212. Here, N is a predetermined number(50~150). Steps 206-210 should be performed repeatedly for series of N sequent superframes because a plurality of sync frames 68, each pattern of which is known, is needed in order to accurately measure the SNR of each sub-channel.

If N SNRs for each sub-channel are obtained, then firstly, the representative SNR( $SNR_{rep}$ ) of each sub-channel is obtained by averaging the N SNRs. Then, the difference value(or first difference value) between the presently obtained  $SNR_{rep}$  and the previously obtained  $SNR_{rep}$  is calculated for each sub-channel. By a method similar to that described above, all first difference values for all sub-channels are obtained in step 214.

The maximum and the minimum values among the first difference values calculated in step 214 are selected in step 216. After step 216, the second difference value between the maximum value and the minimum value is calculated and it is determined whether the second difference value is a predetermined threshold value(around 3 DB) or not in step 218. If the second difference value is

smaller than the threshold value, the procedure feeds back to step 204, and if it is equal to or greater than the threshold value, the bits and power assigned to a corresponding sub-channel in a transmitter are swapped. That is, the number of bit of a sub-channel having a minimum value is assigned to sub-channel having a maximum value. Thus, the corresponding parameters (a bit number and power table) should be changed to enable a receiver to make an accurate decision, in step 220. In step 222, it is determined whether the DMT system is off after step 220. If it is not off, the procedure feeds back to step 204, and if it is off, the bit swapping method of the present invention ends.

Since the bit swapping only takes place once after at least one superframe has been transmitted (17msec is required for one superframe transmission), a long time is required for the bit swapping. However, even though the channel changes during the time required for the bit swapping, this method can be used because a channel changes very slowly, for example by temperature, etc.

Fig.3 shows a device for performing the above-described method. The A/D converter 300 converts an analogue signal received via an input port IN into a digital signal. The TEQ 302 receives the digital signal from the A/D converter 300 and reduces a guard band used to remove an interblock interference (IBI) produced due to characteristics of a DMT system. For this purpose, a finite impulse response filter (FIR) may be used as the TEQ

302. The FFT 304 receives the signal output from the TEQ  
302 and performs a demodulation corresponding to a  
modulation of the transmitter. Thus, the FFT 304 serves as  
a demodulator corresponding to the IFFT 106 of FIG. 1. The  
5 FEQ 306 is a filter for receiving the output of the FFT 304  
and compensating for a phase error of each sub-channel.  
Meanwhile, the SNR measurer 310 of FIG. 3 receives the  
output of the A/D converter 300 and performs the steps 204-  
220 described in Fig.2. The SNR measurer 310 can be  
10 achieved in terms of software in a digital signal  
processor. After processing step 218 shown in Fig.2, the  
SNR measurer 310 outputs the control signal for bit  
swapping to the transmitter via an output port OUT1 to  
correct a bit allocation table at a transmitter, and the  
15 measured SNR of each sub-channel is output to the decoder  
308. The decoder 308 receives the outputs of the SNR  
measurer 310 when frame 68 is input, and the output of the  
FEQ 306 when any frame among frames 0 - 67 is input,  
decides a slicer value, decodes the reset slicer value, and  
20 outputs the decoded value via an output port OUT2.

As described above, in the adaptive bit swapping  
method and device of embodiments of the present invention  
in the DMT system, the method for comparing SNRs is added  
to an SNR measuring method used in a conventional process  
25 of initialization. The adaptive bit swapping device  
selects only frame 68 from each superframe, thereby  
simplifying a conventional complex hardware construction  
using all frames. Furthermore, in the adaptive bit swapping

method, more accurate swapping information for changing the number of bit and corresponding power can be transmitted to a transmitter than in the conventional method depending on an MSE, since an actually measured SNR value on a frame 68 is used when the assigned bit number and the assigned quantity of power are changed according to a channel variation.

CLAIMS

1. An adaptive bit swapping method for use in a discrete multitone (DMT) system for an asymmetric digital subscriber line (ADSL) which has a transmitter for encoding and converting data to be transmitted via a channel, and a receiver for restoring the transmitted data to the original form by conversion and decoding, said method comprising the steps of:

5

10

15

20

25

(a) initializing said DMT system to transmit said data via said channel in a steady state;

(b) selecting a frame having an inserted sync block from a frame structure of said transmitted data;

(c) calculating the signal-to-noise ratios (SNRs) of respective sub-channels of said selected frame;

(d) calculating first difference values between the present representative SNRs calculated in step (c) and the previous representative SNRs of each sub-channel;

(e) selecting a maximum value and minimum value among the first difference values of said respective sub-channels;

(f) obtaining a second difference value being a difference between said maximum value and said minimum value;

(g) determining whether said second difference value is equal to or greater than a predetermined threshold value; and

(h) correcting bit and power assigning tables of a transmitter and a receiver if said second difference value



is greater than or equal to said threshold value.

2. An adaptive bit swapping method as claimed in claim 1, wherein said step (a) comprises the steps of:

5 establishing the initial bits and power values of said DMT system; and

starting a transmission of data in a steady state of said DMT system.

3. An adaptive bit swapping method as claimed in claim 1 or claim 2, wherein said step (c) comprises the steps of;

10 measuring the signal power spectrum density (PSD) of each sub-channel by a deterministic least sequence (DLS) method;

15 measuring a noise PSD of each sub-channel by a Welch method; and

calculating said SNR of each sub-channel from said measured signal PSD and said noise PSD.

20 4. An adaptive bit swapping method as claimed in any of claims 1 to 3, wherein said steps (b) and (c) are performed repeatedly a predetermined number of times, and representative SNR value of each sub-channel are calculated making use of said SNRs if the predetermined number of SNRs is obtained for each sub-channel.

25 5. An adaptive bit swapping method as claimed in claim 4, wherein said step (c) comprises the step of;

feeding the procedure back to said step (b), if said predetermined number of SNRs of each sub-channel has not been obtained .

6. An adaptive bit swapping method as claimed in any preceding claim, wherein said step (g) comprises the step of;

5 feeding the procedure back to said step (b), if said second difference value is not greater than or equal to said predetermined threshold value.

7. An adaptive bit swapping device adapted to function as a receiver for restoring transmitted data to its original form by conversion and decoding, said device  
10 being adapted for inclusion in a discrete multitone (DMT) system for an asymmetric digital subscriber line (ADSL) which has a transmitter for encoding and converting data to be transmitted via a channel, said device comprising:

A/D converting means for converting said analogue data  
15 signal received via said channel into a digital signal;

time-domain equalizing means for receiving said digital signal and reducing a guard band used to remove an interblock interference;

fast-Fourier transforming means for receiving the  
20 output of said time-domain equalizing means and demodulating said data signal modulated in said transmitter;

frequency-domain equalizing means for receiving the  
25 output of said fast Fourier transforming means and compensating for a phase error of each sub-channel;

SNR measuring means for obtaining the representative SNRs of said respective sub-channels from the output of said A/D converting means using a frame having an inserted

sync symbol from a frame structure of transmitted data,  
calculating a first difference values between the previous  
representative SNR and present representative SNR for each  
sub-channel, comparing a threshold value with a second  
5 difference value being a difference between maximum and  
minimum value of said first difference values, and  
outputting to a transmitter and a receiver the signal used  
for correcting a bit allocation table according to the  
compared result; and

10 decoding means for receiving the outputs of said SNR  
measuring means and said frequency-domain equalizing means,  
resetting a slice value, and decoding said reset slice  
value.

8. An adaptive bit swapping device adapted to  
15 function as a receiver for restoring transmitted data to  
its original form by conversion and decoding, said device  
being adapted for inclusion in a discrete multitone (DMT)  
system for an asymmetric digital subscriber line (ADSL)  
which has a transmitter for encoding and converting data to  
20 be transmitted via a channel, said device comprising:

A/D converting means for converting said analogue data  
signal received via said channel into a digital signal;

25 time-domain equalizing means for receiving said  
digital signal and reducing a guard band used to remove an  
interblock interference;

fast-Fourier transforming means for receiving the  
output of said time-domain equalizing means and  
demodulating said data signal modulated in said

transmitter;

frequency-domain equalizing means for receiving the output of said fast Fourier transforming means and compensating for a phase error of each sub-channel;

5 SNR measuring means for selecting a frame having an inserted sync block from a frame structure of said transmitted data, calculating the signal-to-noise ratios (SNRs) of respective sub-channels of said selected frame, calculating first difference values between the present  
10 representative SNRs calculated above and the previous representative SNRs of each sub-channel, selecting a maximum value and minimum value among the first difference values of said respective sub-channels, obtaining a second difference value being a difference between said maximum  
15 value and said minimum value, determining whether said second difference value is equal to or greater than the predetermined threshold value, and outputting to a transmitter and a receiver the signal used for correcting bit and power assigning tables of a transmitter and a  
20 receiver; and

decoding means for receiving the outputs of said SNR measuring means and said frequency-domain equalizing means, resetting a slice value, and decoding said reset slice value.

25 9. An adaptive bit swapping device substantially as herein described with reference to Figure 3 with or without reference to Figures 2 and 4.

10. A discrete multitone (DMT) system for an

asymmetric digital subscriber line (ADSL) which has a transmitter for encoding and converting data to be transmitted via a channel, said system comprising an adaptive bit swapping device as claimed in any of claims 7 to 9.

5

11. An adaptive bit swapping method substantially as herein described with reference to Figure 2 with or without reference to Figures 3 and 4.



Application No: GB 9613602.3  
Claims searched: 1-11

Examiner: David Midgley  
Date of search: 22 October 1996

**Patents Act 1977**  
**Search Report under Section 17**

**Databases searched:**

UK Patent Office collections, including GB, EP, WO & US patent specifications, in:

UK Cl (Ed.O): H4P (PAQ,PAL,PEM)

Int Cl (Ed.6): H04L 5/06,27/34

Other: ONLINE:WPI

**Documents considered to be relevant:**

Category	Identity of document and relevant passage	Relevant to claims
	NONE	

X	Document indicating lack of novelty or inventive step	A	Document indicating technological background and/or state of the art.
Y	Document indicating lack of inventive step if combined with one or more other documents of same category.	P	Document published on or after the declared priority date but before the filing date of this invention.
&	Member of the same patent family	E	Patent document published on or after, but with priority date earlier than, the filing date of this application.

**METHOD OF COMMUNICATION CHANNEL MONITORING USING PARITY BITS**

Publication number: JP10513622 (T)

Publication date: 1998-12-22

Inventor(s):

Applicant(s):

Classification:

- international: H04N7/16; H04B10/207; H04J3/14; H04J3/16; H04L1/00; H04L1/24; H04L5/02; H04L5/14; H04L25/03; H04L27/26; H04M11/06; H04N7/173; H04L27/00; H04N7/16; H04B10/207; H04J3/14; H04J3/16; H04L1/00; H04L1/24; H04L5/02; H04L5/14; H04L25/03; H04L27/26; H04M11/06; H04N7/173; H04L27/00; (IPC1-7): H04L1/00; H04J3/14; H04J3/16; H04M11/06; H04N7/16

- European: H04N7/173B; H04J3/14; H04L1/00B7B; H04L1/24; H04L5/02Q; H04L5/14T2; H04L25/03E3; H04L27/26M2; H04L27/26M3; H04L27/26M5; H04L27/26M5A1P; H04L27/26M5C3

Application number: JP19960524387T 19960206

Priority number(s): WO1996US01606 19960206; US19950384659 19950206; US19950457295 19950601

Also published as:

WO9624995 (A2)

WO9624995 (A3)

TW409475 (B)

EP0808534 (A2)

CN1193433 (A)

more >>

Abstract not available for JP 10513622 (T)

Abstract of corresponding document: WO 9624995 (A2)

A method for monitoring at least one telephony communication n-bit channel, wherein one of the bits is a parity bit, includes sampling the parity bit of the n-bit channel. A probable bit error rate is derived from the sampling of the parity bit. The probable bit error rate can be compared to a pre-determined bit error rate value to determine if the at least one telephony communication n-bit channel is corrupted. If the at least one telephony communication n-bit channel is corrupted, the at least one telephony communication n-bit channel is re-allocated to an uncorrupted and unallocated telephony communication n-bit channel. Further, at least one unallocated telephony communication channel can be periodically monitored and error data accumulated to indicate the quality thereof.

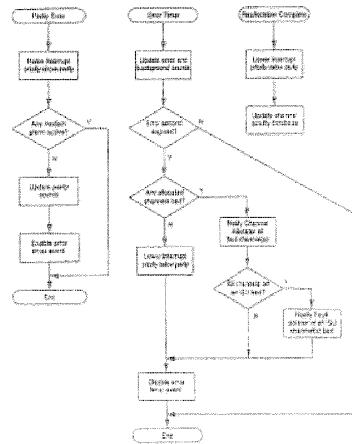

Data supplied from the *espacenet* database — Worldwide

(51)Int.Cl. <sup>6</sup>	識別記号	F I	
H 0 4 L 1/00		H 0 4 L 1/00	C
H 0 4 J 3/14		H 0 4 J 3/14	Z
		3/16	Z
H 0 4 M 11/06		H 0 4 M 11/06	
H 0 4 N 7/16		H 0 4 N 7/16	Z
		審査請求 未請求	予備審査請求 有 (全144頁)

(21)出願番号	特願平8-524387	(71)出願人	エーディーシー テレコミュニケーションズ、インコーポレイティド アメリカ合衆国、ミネソタ 55435、ブルーミントン、ウエスト セブンティエイズ ストリート 4900
(86) (22)出願日	平成8年(1996)2月6日	(72)発明者	アンダーソン、プライアン ディー、 アメリカ合衆国、ミネソタ 55442、プリマウス、フィフティース プレイス ノース 11430
(85)翻訳文提出日	平成9年(1997)8月6日	(74)代理人	弁理士 石田 敬 (外3名)
(86)国際出願番号	PCT/US96/01606		
(87)国際公開番号	WO96/24995		
(87)国際公開日	平成8年(1996)8月15日		
(31)優先権主張番号	08/384,659		
(32)優先日	1995年2月6日		
(33)優先権主張国	米国 (US)		
(31)優先権主張番号	08/457,295		
(32)優先日	1995年6月1日		
(33)優先権主張国	米国 (US)		

最終頁に続く

(54)【発明の名称】 通信チャンネルをモニタする方法

(57)【要約】

少なくとも1つの電話通信nビットチャンネルをモニタする方法であって、該ビットの1つはパリティビットであり、該nビットチャンネルのパリティビットをサンプリングすることを含む。予想されるビットエラー率は該パリティビットのサンプリングから求められる。該予想されるビットエラー率は、少なくとも1つの電話通信nビットチャンネルがこわれているかどうかを決定するために、予め定められたビットエラー率の値と比較される。もし少なくとも1つの電話通信nビットチャンネルがこわれているならば、該少なくとも1つの電話通信nビットチャンネルは、こわれておらずかつ割当てられていない電話通信nビットチャンネルに再割当てされる。更に、少なくとも1つの割当てられていない電話通信チャンネルが周期的にモニタされ、エラーデータがその品質を示すために累積される。

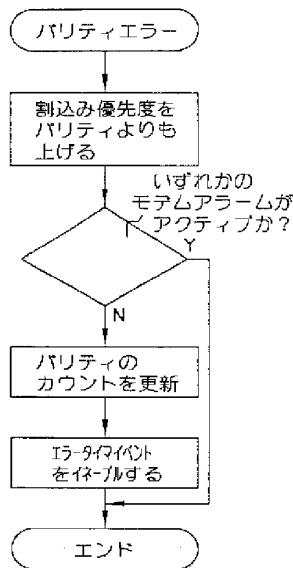

FIG. 29A



## 【特許請求の範囲】

1. 少なくとも1つの電話通信nビットチャンネルをモニタする方法であって、該ビットの1つがパリティビットであり、

該nビットチャンネルのパリティビットをサンプリングするステップと、

該パリティビットのサンプリングから予想されうるビットエラー率を求めるステップとを具備する方法。

2. 少なくとも1つの割当てられていない電話通信チャンネルに対して、エラーデータを周期的にモニタし累積するステップを更に備えた、請求項1に記載の方法。

3. 少なくとも1つの電話通信nビットチャンネルがこわれているかどうかを決定するために、予想されうるビットエラー率を、予め決定されたビットエラー率の値と比較するステップと、

もし少なくとも1つの電話通信nビットチャンネルがこわれているならば、該少なくとも1つの電話通信nビットチャンネルを、こわれておらずかつ割当てられていない電話通信nビットチャンネルに再割当てするステップとを更に備えた、請求項1に記載の方法。

4. 少なくとも1つの電話通信nビットチャンネルがこわれているかどうかを決定するために、予想されうるビットエラー率を、予め決定されたビットエラー率の値と比較するステップと、

もし該nビットチャンネルがこわれているならば、システム全体の電力を維持している間、該nビットチャンネルの伝送パワーを増加するステップとを更に備えた、請求項1に記載の方法。

5. 少なくとも1つの電話通信nビットチャンネルをモニタする方法であって、該ビットの1つがパリティビットであり、

該nビットチャンネルのパリティビットをサンプリングするステッ

プと、

ある期間に亘って該パリティビットのサンプリングから予想されうるビットエラー率を求めるステップと、

該 n ビットチャネルがこわれているかどうかを決定するために、ある期間に亘って予想されうるビットエラー率を予め定められたビットエラー率の値と比較するステップとからなる方法。

6. 該比較にもとづいて、該 n ビットチャネルから異なる n ビットチャネルに通信を再割当てするステップを更に備える、請求項 5 に記載の方法。

7. 少なくとも 1 つの電話通信 n ビットチャネルが、複数の電話通信の n ビットチャネルの帯域内に含まれており、該帯域が少なくとも 1 つの制御チャネルと関連しており、更に異なる n ビットチャネルが該帯域内に配置されている、請求項 6 に記載の方法。

8. 少なくとも 1 つの電話通信 n ビットチャネルが複数の電話通信 n ビットチャネルの帯域内に含まれており、該帯域は少なくとも 1 つの制御チャネルと関連しており、更に異なる n ビットチャネルが、他の少なくとも 1 つの関連した制御チャネルを有する複数の電話通信 n ビットチャネルの第 2 の帯域に配置されている、請求項 6 に記載の方法。

9. もし該 n ビットチャネルがこわれているならば、システム全体の電力を維持している間、該 n ビットチャネルの伝送パワーを増加するステップを更に備えた、請求項 5 に記載の方法。

10. テーブル内に予想されうるビットエラー率を記憶するステップを更に備え、該テーブルは n ビットチャネル上の将来の通信を割当てするために使用されうる、請求項 5 に記載の方法。

11. もし該チャネルがこわれていないならば、少なくとも 1 つのより長い期間に亘ってパリティビットをサンプリングすることから

少なくとも 1 つの付加的な予想されうるビットエラー率を求めるステップと、

該 n ビットチャネルがこわれているかどうかを決定するために、該少なくとも 1 つの付加的な予想されうるビットエラー率を付加的な予め定められたビットエラー率の値と比較するステップとを更に備えた、請求項 5 に記載の方法。

12. 予め定められたビットエラー率の値は電話通信サービスのためであり、付加的な予め定められたビットエラー率の値は、付加的な電話通信サービスのため

である、請求項11に記載の方法。

13. 電話通信サービスの1つはISDNである、請求項12に記載の方法。

14. もし該nビットチャネルがこわれているならば、システム全体の電力を維持している間、該nビットチャネルの伝送パワーを増加させるステップを更に備えた、請求項11に記載の方法。

15. 該少なくとも1つの付加的な予想されうるビットエラー率と付加的な予め定められたビットエラー率の値との比較にもとづいて、該nビットチャネルから異なるnビットチャネルへ該通信を再割当てするステップを更に備えた、請求項11に記載の方法。

16. 少なくとも1つの電話通信nビットチャネルをモニタする方法であって、該ビットの1つがパリティビットであり、

第1の期間に亘って該nビットチャネルのパリティビットをサンプリングするステップと、

該第1の期間に亘る該パリティビットのサンプリングから予想されうるビットエラー率を求めるステップと、

該nビットチャネルがこわれているかどうかを決定するために該第1の期間に亘っての該予想されうるビットエラー率を予め定められたビットエラー率の値と比較するステップと、

もし該nビットチャネルがこわれていないならば、複数の連続する期間に亘って予想されうるビットエラー率を累積するステップとを備えた方法。

17. 該nビットチャネルがこわれているかどうかを決定するために、該連続する期間に亘っての該累積された予想されうるビットエラー率を、少なくとも1つの付加的な予め定められたビットエラー率の値と比較するステップを更に備えた、請求項16に記載の方法。

18. もし該nビットチャネルがこわれているならば、該nビットチャネルからの通信を第2のnビットチャネルに再割当てするステップを更に備えた、請求項17に記載の方法。

19. もし該nビットチャネルがこわれているならば、システム全体の電力を維

持している間、該 n ビットチャネルの伝送パワーを増加するステップを更に備えた、請求項17に記載の方法。

20. 該予め定められたビットエラー率の値は電話通信サービスと関連しており、また該少なくとも1つの付加的な予め定められたビットエラー率の値は、少なくとも1つの付加的な電話通信サービスと関連している、請求項19に記載の方法。

21. 該電話通信サービスの1つはISDNである、請求項20に記載の方法。

22. もし該 n ビットチャネルがこわれているならば、該 n ビットチャネルから第2の n ビットチャネルに通信を再割当てするステップを更に備えた、請求項16に記載の方法。

23. もし該 n ビットチャネルがこわれているならば、システム全体の電力を維持している間、該 n ビットチャネルの伝送パワーを増加するステップを更に備えた、請求項16に記載の方法。

24. 少なくとも1つの電話通信 n ビットチャネルをモニタする方法であって、該ビットの1つはパリティビットであり、

該 n ビットチャネルのパリティビットをサンプリングするステップと、

第1の期間に亘って該パリティビットをサンプリングすることから予想されうるビットエラー率を求めるステップと、

該 n ビットチャネルがこわれているかどうかを決定するために、該第1の期間に亘っての予想されうるビットエラー率を第1の予め定められたビットエラー率の値と比較するステップと、

第2の期間に亘って該パリティビットをサンプリングすることから予想されうるビットエラー率を求めるステップであって、該第2の期間は該第1の期間より長くされていて該第1の期間と同時に経過するものと、

該 n ビットチャネルがこわれているかどうかを決定するために該第2の期間に亘って該予想されうるビットエラー率を第2の予め定められたビットエラー率の値と比較するステップとを備えた方法。

25. もし該 n ビットチャネルがこわれていなければ、該 n ビットチャネルから

第2のnビットチャンネルに通信を再割当てするステップを更に備えた、請求項24に記載の方法。

26. もし該nビットチャンネルがこわれていれば、システム全体の電力を維持している間、該nビットチャンネルの伝送パワーを増加させるステップを更に備えた、請求項24に記載の方法。

27. テーブル内に該予想されうるビットエラー率を記憶するステップを更に備え、該テーブルはnビットチャンネル上の将来の通信を割当てするために使用される、請求項24に記載の方法。

28. 少なくとも1つの割当てられていない電話通信チャンネルをモニタする方法であって、

該少なくとも1つの割当てられていない電話通信チャンネルを周期的にモニタするステップと、

該少なくとも1つの割当てられていない電話通信チャンネルに対するエラーデータを累積するステップと、

該少なくとも1つの割当てられていない電話通信チャンネルを、該エラーデータにもとづいて、割当てられるのを許容するステップとからなる方法。

29. こわされた電話通信チャンネルから、少なくとも1つの割当てられていない電話通信チャンネルに、電話通信を再割当てするステップを更に備えた、請求項28に記載の方法。

30. 少なくとも1つの割当てられていない電話通信チャンネルを周期的にモニタする方法であって、

遠隔の送信機から、複数ビットの1つがパリティビットであるnビットの信号を送信するステップと、

nビットチャンネルのパリティビットをサンプリングするステップと、

該サンプリングされたパリティビットから予想されうるビットエラー率を求めるステップとを含む、請求項28記載の方法。

31. 割当てられていないチャンネルがパワーダウンされた割当てチャンネルである方法であって、

該チャンネルがモニタされうるように、割当てられていないチャンネル上の遠隔の位置で遠隔のトランスミッタをパワーアップするステップと、

該チャンネルがモニタされた後で該遠隔のトランスミッタをパワーダウンするステップとを更に含む、請求項28に記載の方法。

32. 該チャンネルがこわれているかどうかを決定するために、予想されうるビットエラー率を予め定められたビットエラー率と比較するステップを更に備えた、請求項28に記載の方法。

33. 少なくとも1つの割当てられていない電話通信チャンネルが、

複数の割当てられていない電話通信チャンネルの1つであり、少なくとも或る数の割当てられていない電話通信チャンネルがモニタされる方法であって、このようなモニタリングにもとづいて少なくとも或る数の割当てられていないチャンネルの品質をランク付けするステップを含む、請求項28に記載の方法。

34. 該ランク付けするステップは、高品質のチャンネルをスタンバイチャンネルとしてわきにセットすることを含む、請求項33に記載の方法。

**【発明の詳細な説明】**

通信チャンネルをモニタする方法

発明の分野

本発明は一般的には通信システムの分野に関し、特に本発明は通信チャンネルのモニタリングに関する。

発明の背景

最近、家庭とビジネスで見出される2つの情報サービスにはテレビジョン又はビデオサービスおよび電話サービスを含む。他の情報サービスにはデジタルデータ転送を含み、これはしばしば電話サービスに接続されたモデムを用いて達成される。ここでの電話に対するすべての更なる引用には、電話サービスとデジタルデータ転送サービスを含む。

電話とビデオの各信号の特性は異なっており、したがって電話とビデオの各ネットワークは異なる設計がなされる。例えば、電話情報は、ビデオ信号に対する帯域幅と比較したとき、比較的狭い帯域を占有する。更に、電話信号は低周波数であるのに対し、NTSC基準ビデオ信号は50MHzより高いキャリア周波数で伝送される。したがって電話伝送ネットワークはオーディオ周波数で動作する比較的狭い帯域幅システムであり、このシステムは通常壁受側接合ボックスから降下するねじれたワイヤによって顧客にサービスする。他方、ケーブルテレビジョンサービスは広帯域であり、従来の非常に高い周波数のテレビジョン受信器と両立しうる信号を達成するために種々の周波数キャリア混合方法を組み込む。ケーブルテレビジョンシステム又はビデオサービスは典型的には各個々家庭又はビジネスへのシールドされたケーブルサービス接続を通してケーブルテレビジョン会社によって提供される。

電話及びビデオサービスを単一のネットワークに組合せる1つの試みは、“光通信ネットワーク”と題するBalanceへの米国特許4,977,593号に記載されている。Balanceには中央局に配置された光源を有する受動的な光通信網が記載されている。該光源は光ファイバーに沿って時分割多重光信号を送信し、この信号はいくつかの個別的なファイバーをサービスする支所間の一連のスプリッタによって後

で分割される。該ネットワークは同じ光学的経路を介して、デジタル音声データが支所から中央局まで伝送されるのを許容する。更に Balanceは付加的な波長がデジタル多重を介して該ネットワークへ、ケーブルテレビジョンのようなサービスを加えるために利用されうることを示している。

James A.Chiddixと David M.Pangracによる“ファイバー“バックボーン：進化論的なケーブルTVネットワークアーキテクチャに対する提案”と題する1988年NCTAテクニカルペーパーには、ハイブリッド光ファイバー／同軸ケーブルテレビジョン（CATV）システムのアーキテクチャについて記載されている。該アーキテクチャは既存の同軸CATVネットワークで構成する。該アーキテクチャは既存のCATV分配システムにおけるヘッドエンドからいくつかのフィードポイントへの直接的な光ファイバー経路の使用を含む。

“光波伝送ラインを用いたCATV分配ネットワーク”と題するPidgeonに対する米国特許第 5,153,763号には、ヘッドエンドから複数の加入者への広帯域多重チャンネルCATV信号の分配に対するCATVネットワークについて記載されている。ヘッドエンドにおける電気から光へのトランスミッタおよびファイバーノードにおける光から電気へのレシーバは、広帯域CATV電気信号に対応する光信号を放射させ

かつ受信する。光ファイバーノードからの分配は、同軸ケーブルの伝送ラインに沿って電気信号を送信することによって得られる。該システムは、すべての又は一部の広帯域CATV信号を1オクターブより小さい周波数範囲にブロック変換することによって、送信された広帯域CATV信号のひずみを減少させる。“光波伝送ラインを使用したCATV分配ネットワーク”と題する Pidgeonに対する関連米国特許第 5,262,883号には更にひずみを減少させるシステムについて記載されている。

上述の各ネットワークはハイブリッド光ファイバー／コアックスアーキテクチャを含む、種々のアーキテクチャに亘って広帯域ビデオ信号を送信することに対する種々の概念を示している。しかしこれらの参照例のいずれにも電話通信に対するコストのかからないフレキシブルな通信システムについて記載されていない。いくつかの問題は、かかる通信システムにおいて固有のものである。

1つのかかる問題は、使用される帯域幅が割当てられた帯域幅を超えないよう



にトランスポートデータに対して使用される帯域幅を最適化する必要性である。帯域幅の条件は、多対1の通信において特に重要であり、ここでは遠隔のユニットにある多くのトランスミッタが、割当てられた帯域幅を超えないように適応されなければならない。

第2の問題はシステムの電力消費を含む。通信システムはデータのトランスポートに対し遠隔のユニットにおいて用いられる電力を最小にすべきである。その理由は、送受信に対して遠隔のユニットで利用される設備は、システムの伝送メディアに亘って分配される電力によって供給されうるからである。

データの完全さにも配慮されなければならない。内部および外部の干渉は通信の品質を低下させる。内部干渉はシステムに亘ってト

ランスポートされるデータ信号の間に存在する。すなわち共通の通信リンクに亘ってトランスポートされるデータ信号は、それらの間で干渉を経験し、データの完全性を低下させる。外部供給源からのイングレスもまたデータ伝送の完全性に影響を及ぼす。電話通信ネットワークは外部供給源によって発生されるHAM無線のような“ノイズ”の影響を受け易い。このようなノイズは間欠的で強度が変化しうるので、システムに亘ってデータをトランスポートする方法は正確でまたこのようなイングレスの存在を避けるべきである。

これらの問題およびその他については、質の高い通信システムに対する必要性を示す以下の記述から明らかとなるであろう。

#### 発明の概要

多対1の通信システムに固有の問題のいくつかを配慮した、特にイングレスに関して配慮したチャンネルモニタリングの使用について記述される。本発明のモニタ方法は、複数ビットの1つがパリティビットである電話通信nビットチャンネルをモニタする。該nビットチャンネルのパリティビットはサンプリングされ、該パリティビットのサンプリングから予想されうるビットエラー率が求められる。

1実施例では、ある期間に亘る該予想されうるビットエラー率が、該nビットチャンネルがこれわているかどうかを決定するために、最小ビットエラー率を表す予め定められたビットエラー率の値と比較される。こわれたチャンネルは再割当て

されうるか、又は他の実施例では、その崩壊を克服するために該チャネルの伝送パワーが増加されうる。

別の方法の実施例では、該方法は、第1の期間に亘って該nビットチャネルのパリティビットをサンプリングするステップと、該第1の期間に亘るパリティビットのサンプリングから予想されうるビ

ットエラー率を求めるステップと、該第1の期間に亘る該予想されうるビットエラー率を、該nビットチャネルがこわれているかどうかを決定するために予め定められたビットエラー率の値と比較するステップと、もし該nビットチャネルがこわれていなければ複数の連続する期間に亘って予想されうるビットエラー率を累積するステップとをそなえる。

更に他の方法の実施例では、該方法は、該nビットチャネルのパリティビットをサンプリングするステップと、第1の期間に亘る該パリティビットのサンプリングから予想されうるビットエラー率を求めるステップとをそなえる。該第1の期間に亘る該予想されうるビットエラー率は、該nビットチャネルがこわれているかどうかを決定するために、第1の予め定められたビットエラー率の値と比較される。第2の期間に亘るパリティビットのサンプリングから予想されうるビットエラー率が求められる。該第2の期間は該第1の期間より長く、かつ同時に経過する。該nビットチャネルがこわれているかどうかを決定するために、該第2の期間に亘る予想されうるビットエラー率が、第2の予め定められたビットエラー率の値と比較される。

更に他の変形実施例においては、少なくとも1つの割当てられていない電話通信チャネルをモニタする方法は、少なくとも1つの割当てられていない電話通信チャネルを周期的にモニタすることを含む。該少なくとも1つの割当てられていない電話通信チャネルに対するエラーデータは累積され、該少なくとも1つの割当てられていない電話通信チャネルは該エラーデータにもとづいて割当てられる。

。 図面の簡単な説明

図1は、ハイブリッドファイバー／コアックス分配ネットワークを用いた本発明による通信システムのブロック図を示す。

図2は、図1のシステムの別の実施例である。

図3は、図1のシステムのトランスミッタおよびレシーバに関連したホストデジタル端末(HDT)の詳細なブロック図である。

図4は、図3の関連したトランスミッタおよびレシーバのブロック図である。

図5は、図1のシステムの光分配ノードのブロック図である。

図6は、図1のホーム統合サービスユニット(HISU)又はマルチ統合サービスユニット(MISU)のような、統合サービスユニット(ISU)の一般的なブロック図である。

図7A, 7B, 7Cは、図3のHDTに利用されるデータフレーム構造およびフレームシグナリングを示す。

図8は、図3のコアックスマスターユニット(CXMU)のコアックスマスターカード(CXMC)の一般的なブロック図である。

図9Aは、図1のシステムにおける電話トランスポートに対する第1のトランスポート実施例に対するスペクトル割当てを示す。

図9Bは、QAM変調に対するマッピング図を示す。

図9Cは、BPSK変調に対するマッピング図を示す。

図9Dは、図9Aのスペクトル割当てに対するサブバンド図を示す。

図10は、図1のシステムの第1のトランスポート実施例に対するCXMUのマスターコアックスカード(MCC)下り伝送アーキテクチャのブロック図である。

図11は、図1のシステムの第1のトランスポート実施例に対するMISUのコアックストランスポートユニット(CXTU)下りレシーバアーキテクチャのブロック図である。

図12は、図1のシステムの第1のトランスポート実施例に対するHISUのコアックスホームモジュール(CXHM)下りレシーバアーキテクチャのブロック図である。

図13は、図12のCXHM下りレシーバアーキテクチャと関連したCXHM上り伝送アー

キテクチャのブロック図である。

図14は、図11のCXTU下りレシーバアーキテクチャと関連したCXTU上り伝送アーキテクチャのブロック図である。

図15は、図10のMCC下り伝送アーキテクチャと関連したMCC上りレシーバアーキテクチャのブロック図である。

図16は、図1のシステムで使用される獲得物分配ループルーチンのフローチャートである。

図17は、図1のシステムで使用されるトラッキング分配ループ体系ルーチンのフローチャートである。

図18は、図15のMCC上りレシーバアーキテクチャの多相フィルタバンクのマグニチュード応答を示す。

図19は、図18のマグニチュード応答の一部拡大図である。

図20は、図15のMCC上りレシーバアーキテクチャのイングレスフィルタ構成およびFFTのブロック図である。

図21は、図20のイングレスフィルタ構成およびFFTの多相フィルタ構造のブロック図である。

図22Aは、第1のトランスポート実施例の下りレシーバアーキテクチャのキャリア、振幅、タイミング再生ブロックのブロック図である。

図22Bは、第1のトランスポート実施例のMCC上りレシーバアーキテクチャのキャリア、振幅、タイミング、再生ブロックのブロック図である。

図23は、第1のトランスポート実施例のレシーバアーキテクチャ

に対する内部イコライザ動作のブロック図である。

図24は、図1はシステムにおけるトランスポートに対する第2のトランスポート実施例のスペクトル割当てである。

図25は、図1のシステムの第2のトランスポート実施例に対するCXMUのMCCモデムアーキテクチャのブロック図である。

図26は、図1のシステムの第2のトランスポート実施例に対するHISUの加入者モデムアーキテクチャのブロック図である。

図27は、図26の加入者モデムアーキテクチャのモデムのブロック図である。

図28は、図1のシステムで用いられるチャンネルモニタに対するブロック図である。

図29A, 29B, 29Cは、図28のチャンネルモニタルーチンのエラーモニタ部分に対するフローチャートである。

図29Dは、図29Bに対する別のフローチャートである。

図30は、図28のチャンネルモニタルーチンのバックグラウンドモニタ部分に対するフローチャートである。

図31は、図28のチャンネルモニタルーチンのバックアップ部分に対するフローチャートである。

#### 好適な実施例の詳細な説明

通信システム10は、本発明の図1に示すように、ハイブリッドファイバー・同軸(HFC)分散ネットワーク11上で家庭及びビジネス電話通信サービスを提供するために主として設計されたアクセスプラットフォームである。システム10は、電話やビデオサービスの提供にとって価格的に有効なプラットフォームである。電話サービスは標準的な電話、コンピュータデータ及び/又はテレメトリを含む。加えて、本システムは住居の加入者に対して現存する明

確なサービスに適応するためのフレキシブルプラットフォームである。

ハイブリッドファイバー・同軸分散ネットワーク11は、中央局又はヘッドエンド32から遠隔に配置された分散ノード18(以下、光分散ノード(ODN)と称する)に電話及びビデオサービスを提供するために光ファイバーフィーダラインを利用する。ODN18から、サービスは同軸ネットワークを経て加入者に分散される。HFC基底通信システム10を利用することにより幾つかの利点が存在する。フィーダにインストールされたファイバーを利用することにより、システム10は100の加入者においてオプトエレクトロニクスの価格をばらまく。分散点から各加入者(「スター」分散アプローチ)に設けられた分離した銅ループを持つ代わりに、システム10は、分散同軸脚部30がサービスのために各家庭及び加入者「タップ」を通るためのバスアプローチを設置する。システム1

0は、非ビデオサービスが、RFスペクトルの専用部分にてより價格的に有効なRFモデム装置を使用して伝送するために変調されることを許容する。最終的に、システム10は、同軸分散リンクが現存するケーブル・レディTVセットを直接駆動することができるので、ビデオサービスが、何ら追加の加入者機器を必要とせずに現存する同軸設備上で担持されることを許容する。

ここで述べるモデムトランスポート・アーキテクチャー、アーキテクチャーの機能性、及びこのようなアーキテクチャーを囲む動作がハイブリッドファイバー・同軸ネットワークよりむしろ分散ネットワークで利用されることは、当業者において明らかである。例えば、機能性は無線システムにおいて実行される。それ故、本発明は添付の請求項に従ってそのようなシステムの使用を企図する。

システム10は、ネットワークインタフェース、同期、DSOG

ルーミング、及び動作、さらに管理、保守及び準備インタフェース(OAM&P)、のような電話トランスポートのための共通の機器機能を備え、さらに、統合サービスユニット100(ISU)のような顧客インタフェース機器へ又はからの情報を担うトランスポートシステムとスイッチングネットワークの間のインタフェースを含むホストデジタル端末12(HDT)を含む。家庭用統合サービスユニット(HISU)68又は多重の居住統合サービスユニットに対向するようなビジネス統合サービスユニットを含む多重ユーザ統合サービスユニット(MISU)66のような、統合サービスユニット(ISU)100は、全ての顧客インタフェース機能及びスイッチされたネットワークへ又はから情報を担うトランスポートシステムへのインタフェースを設置する。本発明のシステムにおいて、HDT12は通常中央局に位置され、ISU100は遠隔の種々の位置に分散されて配置される。HDT12及びISU100は、多対点形態のもとにハイブリッドファイバー・同軸分散ネットワーク11を経て接続される。本発明において、HFC分散ネットワーク11上で情報をトランスポートするために必要とされるモデムの機能性は、HDT12及びISU100の両方におけるインタフェース機器により実行される。このようなモデムの機能性は、直交周波数分割マルチプレックスを利用して実行される。

通信システムは一般的に図1、3及び6に記載される。システム10の基本構成は、ホストデジタル端末(HDT)12、ビデオホスト分散端末(VHDT)34、電話下りトランスミッタ14、電話上りレシーバ16、光分散ノード18を含むハイブリッドファイバー同軸(HFC)分散ネットワーク11、及び遠隔ユニット46に関連した統合サービスユニット66、68(図6にて一般にISU100として示す)である。HDT12は、スイッチングネット

ワーク(一般にトランクライン20で示される)と、電話情報のトランスポートのためのHFC分散ネットワークへのモデムインタフェースとの間の電話インタフェースを提供する。電話下りトランスミッタ14は、図3に示すように、HDT12の同軸RF下り電話情報出力22に対する電気-光学変換を実行し、冗長下り光ファイバーフィーダライン24に送信する。電話上りレシーバ16は冗長上り光ファイバーフィーダライン26上の光信号に対する光学-電気変換を行い、HDT12の同軸RF上り電話情報入力28に電気信号を与える。光分散ノード(ODN)18は、光ファイバーフィーダライン24及び26と同軸分散脚部30の間のインタフェースを提供する。ODN18は同軸分散脚部30上で下りビデオ及び電話を結合する。統合サービスユニットは、同軸分散ネットワークへのモデムインタフェース及び顧客へのサービスインタフェースを提供する。

HDT12及びISU100は、電話トランスポートシステム変調-復調(モデム)機能を設置する。HDT12は、図3に示すように、少なくとも1つのRF-MCCモデム82を含み、各ISU100は図6に示すように、RI-ISUモデム101を含む。MCCモデム82及びISUモデム101は、電話情報をトランスポートするために、HDT12とISU100の間で、DSO+チャネルのような、多重キャリアRF送信技術を使用する。この多重キャリア技術は、システムの帯域幅が多重キャリアに分割された直交周波数分割マルチプレックス(OFDM)に基づき、その各々は情報チャンネルを示す。マルチキャリア変調は、時分割マルチプレックス情報データをとり、これを周波数分割マルチプレックスデータに変換する技術として見ることができる。

多重キャリア上のデータの発生及び変調は、各データチャンネル上

の直交変換を使用してデジタル的に達成される。レシーバは、データを復調するためにサンプル波形のセグメント上で逆変換を実行する。多重キャリアはスペクトル的にオーバーラップする。しかしながら、変換の直交性の結果として、各キャリアのデータは、他のキャリアから無視しうるインタフェース、従って、トランスポートされたデータ信号の間で減小するインタフェース、で復調される。マルチキャリア送信は、特に多対点システムの上り通信において必要とする送信帯域の効率的な利用を得る。マルチキャリア変調は、また多重マルチプレックスデータストリームをアクセスするための効率的な手段を提供し、帯域のいかなる部分においてもマルチプレックス情報を抽出されるためにアクセスされることを許容し、比較的長いシンボル時間を持つ結果としてインパルスノイズを除いた多くのノイズを提供し、そして、グレードの下げられたキャリアを明らかにすることにより狭帯域の干渉を除去し、データ送信のキャリアの使用を禁止する有効な手段を提供する（このようなチャンネル監視及び保護は以下に詳しく説明される）。本質的に、電話トランスポートシステムは、干渉及び劣った性能を持つキャリアの使用を無力にすることができ、送信品質目標を持つキャリアのみを使用する。

さらに、ODN 18は下りビデオを同軸分散脚部30上の送信のための電話情報と結合する。通常、トランクライン20で示される現存するビデオサービスからのビデオ情報はヘッドエンド32にて受信され処理される。ヘッドエンド32又は中央局は、ビデオデータインタフェースのためのビデオホスト分散端子34（VHDT）を含む。VHDT34は、分散ネットワーク11のODN18を経て遠隔ユニット46へビデオ情報を通信するために関係した光トランスミッタを持つ。

図3及び4に示すHDT12の電話トランスミッタ14は、送信

される電話データを保護するために下り電話送信のための2つのトランスミッタを含む。これらのトランスミッタは従来のものであり、比較的高価でない狭帯域レーザトランスミッタである。1つのトランスミッタは、もし他のものが本来的に機能しているならばスタンバイしている。動作中のトランスミッタにおいて障害を検出すると、送信はスタンバイトランスミッタに切り換わる。反対に、VH



D T 3 4 のトランスミッタは、広帯域アナログ D F B レーザトランスミッタなので H D T 1 2 のトランスミッタと比較して比較的高価である。それ故、ビデオ情報の保護、電話データでない非本質的サービスは保護されずに残される。ビデオデータ送信から電話データ送信を分割することにより、電話データのみの保護が達成できる。ビデオデータ情報及び電話データが、高価な広帯域アナログレーザにより 1 つの光ファイバー上で送信されたならば、経済は電話サービスの保護が不可能であることを指図する。それ故このような送信の分離は重要である。

さらに図 1 を参照すると、ビデオ情報は、下りで光ファイバーライン 4 0 を経てスプリッタ 3 8 へ光学的に送信され、スプリッタ 3 8 は、複数の光ファイバーライン 4 2 上で複数の分散ノード 1 8 へ送信するための光ビデオ信号を分離する。H D T 1 2 と関連した電話トランスミッタ 1 4 は光ファイバーフィーダライン 4 2 を経て光分散ノード 1 8 へ光電話信号を送信する。光分散ノード 1 8 は、ハイブリッドファイバー同軸 ( H F C ) 分散ネットワーク 1 1 の同軸分散部分を経て複数の遠隔ユニット 4 6 への電気的な出力として送信するために、光ビデオ信号及び光電話信号を変換する。電気的な下りビデオ及び電話信号は、H F C ネットワーク 1 1 の同軸分散部分の複数の同軸脚部 3 0 及び同軸タップ 4 4 を経て I S U へ分散される。

遠隔ユニット 4 6 は、図 6 に示すように、I S U 1 0 0 と関連しており、I S U 1 0 0 は、例えば電話及びデータ端子からの電話情報を含む上り電気的データ信号を送信する手段を含み、さらに、以下に説明するように、セットトップボックス 4 5 からセットトップ情報を送信する手段を含む。上り電気的データ信号は、複数の I S U 1 0 0 により H F C 分散ネットワーク 1 1 の同軸部分を経て接続された光分散ノード 1 8 に提供される。光分散ノード 1 8 は、光ファイバーフィーダライン 2 6 上でヘッドエンド 3 2 に送信するために上り電気的データ信号を上り光データ信号に変換する。

図 2 は、ヘッドエンド 3 2 から光分散ノード 1 8 へ光ビデオ信号及び光電話信号の送信を提供する他の実施形態を示し、この実施形態の H D T 1 2 及び V H D T 3 4 は同じ光トランスミッタ及び同じ光ファイバーフィーダライン 3 6 を利用

する。H D T 1 2 及び V H D T 3 4 からの信号は結合され、光学的にヘッドエンド 3 2 からスプリッタ 3 8 に送信される。結合された信号はスプリッタ 3 8 により分離され、4 つのスプリット信号は、同軸分散脚部 3 0 及び同軸タップ 4 4 により遠隔ユニットへの分散のために光分散ノード 1 8 に提供される。O D N 1 8 からの戻り光電話信号はヘッドエンドへの供給のためにスプリッタ 3 8 にて結合される。しかしながら、上述したように、利用される光トランスミッタは、その広帯域能力により比較的高価であり、本質的な電話サービスの保護を与えることができる蓋然性を少なくする。

当業者が認識するように、ファイバーフィーダライン 2 4 及び 2 6 は、図 1 に示すように、2 つは下り電話トランスミッタ 1 4 からの下り送信で、2 つは上り電話レシーバ 1 6 への上り送信のための 4 つのファイバーを含む。指向性カプラーが使用されると、このようなファイバーの数は半分にカットされる。さらに、保護トランス

ミッタ及び利用されるファイバーの数は、当業者にて知られるように変化し、いずれかリストされた数は添付の請求項に記載のように本発明に限定されない。

本発明はより詳細に記載される。記載の第 1 の部分は基本的にビデオトランスポートを扱う。残りの記載は基本的に電話トランスポートを扱う。

#### ビデオトランスポート

通信システム 1 0 はトランクライン 2 0 を経てビデオ及び電話サービスプロバイダからビデオ及び電話情報を受けるヘッドエンド 3 2 を含む。ヘッドエンド 3 2 は複数の H D T 1 2 及び V H D T 3 4 を含む。H D T 1 2 は、電話サービスプロバイダへ又はから T 1 . I S D N への電話情報、又は他のデータサービス情報を通信するためのネットワークインタフェースを含み、このような通信はトランクライン 2 0 で示される。V H D T 3 4 は、例えばケーブル T V 情報のようなビデオ情報を通信するビデオネットワークインタフェースと、ビデオサービスプロバイダへ又はからの加入者の対話データを含み、このような通信はトランクライン 2 0 で示される。

V H D T 3 4 はビデオ光ファイバーライン 4 を経てスプリッタ 3 8 へ下り光信

号を送信する。受動光スプリッタ38は効率的に下り高帯域幅光ビデオ信号の4つのコピーを作る。コピーされた下り光ビデオ信号は、対応して接続された光分散ノード18に分散される。当業者においては下りビデオ信号の4つのコピーが作られるが、コピーの如何なる数も適当なスプリッタにより作られることを容易に認識し、本発明は特定の数に限定されない。

スプリッタは、高価な広帯域の光-電気変換ハードウェアを採用することなく広帯域光信号を分離する受動手段である。光信号スプリッタは当業者には共通に知られており、例えばGould社のよ

うな、多くの光ファイバーコンポーネント製造者から入手できる。他の場合として、能動スプリッタも利用される。さらに、カスケードチェインの受動又は能動スプリッタが、光分散ノードの追加した数に適用するために複写した光信号の数を掛け、それにより単一のヘッドエンドにてサービス可能な遠隔ユニットを増大する。このような変形例は添付の請求項に記載のように本発明に従って企図される。

VHDT34は、中央局ケーブルTVヘッドエンド又は遠隔局及び112NTSCチャンネルまでの放送にて配置される。VHDT34は、現在は譲受人の補助としてのAmerican Lightwave System社から入手可能なLite Amp™のような伝送システムを含む。ビデオ信号は、信号が受信される(即ち、光送信がRFビデオ信号で変調されるテラヘルツキャリアである)同じ周波数で1300ナノメートルレーザー源の振幅変調により光学的に送信される。下りビデオ送信帯域幅は約54-725MHzである。受信したビデオ信号の周波数としてビデオ信号の光送信のために同じ周波数を使用することの利点は、減少した変換費用とともに高帯域幅送信を提供することである。この同じ周波数送信アプローチは、下りの変調が光-電気変換又はフォトダイオードによる比例変換及び恐らく増幅を必要とし、周波数変換でないことを意味する。さらに帯域幅の減少及び分解能の低損失のサンプルデータはない。

光分散ノード18は、図5に示すように、光ファイバーフィーダライン42上でスプリッタ38からスプリット下り光ビデオ信号を受ける。下り光ビデオ信号

は光分散ノード18の下りビデオレーザ400に与えられる。利用される光ビデオレーザ400は、American Lightwave System社から入手可

能なLite Amp<sup>TM</sup> プロダクトラインのものである。フォトダイオードを利用した比例して変換されたビデオレーザ400から変換された信号は、下り電話レーザ402からの変換された電話信号にそってブリッジャー (bridge) 増幅器403に与えられる。ブリッジャー増幅器403は、同時にダイプレックスフィルタ406に4つの下り電気的な電話及びビデオ信号を与え、ダイプレックスフィルタ406は、2つの異なる周波数帯域幅の信号が上り及び下り送信に利用される時に、送信及び受信機能を分離することにより全二重動作を許容する。ビデオ又は下り電話信号についてODN18で実行される周波数変換はなく、信号は、ODN18で受信されたと同じ周波数帯域でHFC分散ネットワーク11の同軸部分を介して遠隔ユニットへ、ODNを経て送られる。

ODN18が下り光ビデオ信号を受信し、信号が下り電気的ビデオ信号に変換された後に、ODN18の4つの出力は、下り電気的ビデオ信号を遠隔ユニット46に送信するために、HFC分散ネットワーク11の同軸部分の4つの同軸脚部30に与えられる。電気的ビデオ信号に対するこのような送信は54-725 MHz帯域幅で生じる。各ODN18は複数の同軸脚部30上の送信のために提供され、出力の如何なる数も添付の請求項に記載のように本発明に従って企図される。

図1に示すように、各同軸ケーブル脚部30は、複数の同軸タップ44を経て下り電気的ビデオ及び電話信号とともに重要な数の遠隔ユニット46を提供することができる。同軸タップは当業者にて共通に知られており、電気信号の受動双方向ピックアップとして作用する。各同軸ケーブル脚部30はシリーズに接続された幾つかの同軸タップ44を有する。さらにHFC分散ネットワーク11の同軸部分は拡張するために幾つかの数の増幅器を使用し、距離データは

このような分散ネットワーク11上の同軸部分上で送られる。

下りビデオ信号は同軸タップ44から遠隔ユニット46に提供される。同軸タップ44からのビデオ信号は、図6にて通常ISU100のブロック図で示されるHISU68に提供される。ISU100はタップ44から下り電氣的ビデオ及び電話信号で提供され、ダイプレックス104に与えられる。下り電氣的ビデオ及び電話信号はダイプレックスフィルタ104を経てイングレスフィルタ105及びISUモデム101に送られる。下りビデオ信号は任意のセットトップボックス45を経てビデオ機器に送られる。ダイプレックスフィルタ104からISUモデム101に与えられる下り電氣的な電話信号は、以下に詳しく記載のよう処理される。

イングレスフィルタ105は、電話やコンピュータ端子のような他のユーザ機器に提供されるものとは反対に、ビデオ機器に与えられる信号の干渉に対抗した保護とともに遠隔ユニット46に提供する。イングレスフィルタ105はビデオ信号を通すが、しかしビデオ機器で利用されない周波数は阻止する。ビデオ機器により使用されないこれらの周波数を阻止することにより、少なくとも同じ遠隔ユニットへネットワークによる他のサービスとともに干渉する浮遊信号は除去される。

セットトップボックス45は遠隔ユニット46における任意の要素である。セットトップボックス45からの対話ビデオデータは、約5乃至40MHzの帯域幅で比較的低い周波数においてビデオサービスプロバイダにより提供される付加的な分離RFモデムにより送信される。このような周波数は、上りと下り電話データ及び下りビデオの伝送に使用される1つではない。

MISU66に対して同軸タップ44からの分離同軸ラインは、同軸タップ44からセットトップボックス45へビデオ信号の送信

を提供し、ビデオ機器47へ下りビデオ信号を提供するために利用される。イングレスフィルタ105は、図6において、ダッシュで表示されるようにMISU66の一部ではない。

VHDT34の他の実施形態は、ビデオ信号の周波数でシフトするために他の変調及び混合方法及び技術を採用し、さらにコード化されたフォーマットで情報

を送信するための他のエンコード方法を採用する。デジタルビデオデータの送信に加えて、アナログビデオデータを送信する技術及び方法は当業者にて知られており、添付の請求項に記載のように本発明の精神及び範囲に従って企図される。

#### 電話トランスポート

図3において、電話情報及びISU動作及びMCCモデム82によりキャリア上で変調された制御データ(以下、制御データ)は、同軸ライン22を経てHDT12及び電話下りトランスミッタ14の間で送信される。電話情報及びISU100によりキャリア上で変調された制御データは電話上りレシーバ16にて受信され同軸ケーブルライン28を経てMCCモデム82に通信される。電話下りトランスミッタ14及び電話上りレシーバ16は、光ファイバーフィードライン24及び26を経て対応する光分散ノード18へ又はから電話情報及び制御データを各々送信し受信する。制御データは、システム11の電話サービス及びHDT12とISU100の間の電話情報のトランスポートを提供するために必要な他の制御データを提供するための、全ての動作、管理、保守、及び準備(OAM & P)を含む。

HDT12のブロック図は図3に示される。HDT12は、以下のモジュール、8つのDS1ユニット(DSUIU)(7つのカッド(quad)DS1ユニットと1つの保護ユニット50)、1つの保護スイッチ&テスト変換ユニット52(PSTU)、2つのク

ロック&タイムスロット・インタチエンジユニット54(CTSU)(1つは現用で1つは予備/保護ユニット)、6つのコアックスマスタユニット56(CXMU)(3つは現用で3つは予備/保護ユニット)、及び2つの電源供給ユニット60(PWRU)(2つは中央局供給から適切なHDT電圧を供給する負荷共用ユニット)である。

HDT12は、通信システム10の電話トランスポートの全ての共通機器機能を備える。HDT12は通常は中央局に配置され、ローカルデジタルスイッチ又はデジタルネットワーク要素機器に直接インタフェースする。HDTは全ての電話情報に対してネットワークインタフェース62を提供する。各HDTは、ネッ

トワーク62において2乃至28DSX-1入力に適合し、これは672DS0チャンネルの最大を示す。

HDT12は、またシステム11における電話トランスポートに対して全ての同期を提供する。HDT12は、外部タイミング、ラインタイミング、内部タイミング、の3つの同期モードのいずれかで動作する。外部タイミングは、HDT12が配置された中央局から発生される供給基準の構築された統合タイミングに同期することを引用する。ラインタイミングは、通常ローカルデジタルスイッチから導かれたDSX-1信号からのリカバーロックに同期する。内部タイミングは、HDTが如何なる有効基準入力の不在にてそれ自身の同期を維持するフリーラン又はホールドオーバー動作である。

HDT12は、1/4-DS0グルーミング・ケイパビリティを提供し、4096×4096フルアクセスと非ブロッキング-1/4-DS0(16kbp/s)クロスコネク・ケイパビリティを提供する。これは、DS0及び1/4-DS0(I SDN "D" チャ

ネル)が、DSX-1ネットワークインタフェース62におけるいずれかのタイムスロットから、いずれかのISU100によりサービスされたいずれかの顧客に対して、ルート化されることを許容する。

HDT12はMCCモデム82を含むHFC分散ネットワーク11上の電話トランスポートに要求されるRFモデム機能性を提供する。HDT12はHFC分散ネットワーク11にモデムインタフェースを提供するために3つの現用CXMU56まで適合し、各現用CXMU56に対して1対1の保護を提供する。

HDT12は、多対点通信システム11の多くのISUの制御及び通信を含む電話トランスポートシステムを統合する。各HDT12モジュールは機能を実行する。DS1Uモジュール48はデジタルネットワーク及びDSX-1終端にインタフェースを提供する。PSTU52は、故障したDS1Uモジュール48に対して保護DS1U50を切り換えることにより、DS1U機器の保護を提供する。CTS U54は、1/4-DS0タイムスロットグルーミング・ケイパビリティ及び全システム同期機能を提供する。CTS U54は、またシステムにおけ

る全ての呼処理を都合する。C X M U 5 6 は、以下に詳しく記載するように、H F C 分散ネットワーク 1 1 上の O F D M 電話トランスポートに対してモデム機能とインタフェースを提供し、S C N U 5 8 は、電話トランスポートに対して全ての O A M & P 機能を提供する通信システムの動作を監視する。準備のための要求の殆どの処理は S C N U 5 8 で実行される。

#### 下り電話トランスミッタ

下り電話トランスミッタ 1 4 は、図 4 に示すように、電話情報及び制御データを担う H D T 1 2 の現用 C X M U 5 6 からの同軸 R F 出力 2 2 をとり、出力 2 2 を下り電話送信信号に結合する。光送信

で要求される電気-光変換ロジックは、より價格的に有効なトランスポート解法を提供するために H D T 1 2 よりむしろ自立形下り電話トランスミッタ 1 4 においてインプリメントされる。個々のコンポーネントにこの機能を置くことにより、この機能の費用は、H D T 1 2 の各 C X M U 5 6 にて繰り返される必要はない。これは C X M U 5 6 の機能のコストを減じ、C X M U 5 6 がファイバーの代わりに同軸上で送信し受信することを許容する。下り電話トランスミッタ 1 4 は、また冗長下りファイバーフィーダライン 2 4 上で O D N 1 8 への送信を提供する。

下り電話トランスミッタ 1 4 は、恐らく 1 0 0 フィート又はそれ以下の距離内で H D T 1 2 と共に配置される。下り電話トランスミッタ 1 4 は、各々 6 M H z 周波数帯域で現用 C X M U 5 6 から同軸 R F 出力を受け、カブラー 2 5 にてそれらを単一の R F 信号に結合する。各 6 M H z 周波数帯域は、当業者で知られるようにガード帯域により分離される。下り電話情報は約 7 2 5 - 8 0 0 周波数帯域で送信される。電話トランスミッタ 1 4 は 1 対 2 スプリッタ ( 図示せず ) を経て結合された信号を通し、それにより冗長下り電気信号を生じる。2 つの冗長信号は、各々電気-光変換のために冗長レーザートランスミッタ 5 0 1 に引き渡され、冗長信号は、下り電話トランスミッタ 1 4 の出力が 2 つのフィーダライン 2 4 で各々が同じ変調された信号を持つように光出力を変調する。これは本発明のシステムの下り電話部分に対する保護を提供する。電話トランスミッタ 1 4 における



両方のヘブリーペロー (Fabry-Perot) レーザは全ての時間でアクティブである。全ての保護機能は光送信の受信端 (ODN 18 に配置される) で提供され、2つのレシーバの内の1つは「アクティブ」として選択され、従って、電話トランスミッタ 14 は保護スイッチングレイバビリティを要求しない。

#### 上り電話レシーバ

上り電話レシーバ 16 は、ODN 18 からの上り光ファイダライン 26 上で上り光電話信号の光-電気変換を実行する。上り電話レシーバ 16 は、通常中央局において HDT 12 とともに配置され、HDT 12 へ電氣的同軸出力と、ビデオセットトップコントローラ (図示せず) に与えられる同軸出力 23 を提供する。上り電話情報は、上り電話レシーバ 16 から HDT 12 の現用 CXMU 56 へ同軸ライン 28 を経てルート化される。HDT 12 と上り電話レシーバ 16 の間の同軸リンク 28 は好適には距離 100 フィート又はそれ以下に限定され、イントラオフィスリンクである。ビデオセットトップコントローラ情報は、ビデオトランスポート部分で記載したように、5乃至40MHzのRFスペクトルの帯域に配置され、この帯域は上り電話情報にそって送信され、上り電話トランスポートに利用されない。

上り電話レシーバ 16 は、デュアル上り光ファイバライン 26 に対してデュアルレシーバ 502 を持つ。これらのファイダライン 26 は、電話情報と制御データとビデオセットトップボックス情報を含むODN 18からの冗長信号を担う。上り電話レシーバ 16 は、ODNからの上りファイダライン 26 上で自動的な保護切り換えを実行する。保護ロジックにより「アクティブ」として選択されたレシーバ 502 はHDT 12を駆動する同軸出力 28に供給するために分離され、出力 23 はセットトップコントローラ (図示せず) に提供される。

#### 光分散ノード

図5に示すように、ODN 18は、HDT 12からの光ファイダライン 24 および 26 と、遠隔のユニット 30 へ通ずる HFC 分散ネットワーク 11 の同軸部分との間のインタフェースを提供する。

このように、ODN18は、基本的に光-電気変換装置であって且つ電気-光変換装置である。ODN18から任意のISUのコアックスまでの最も長い距離は、好ましくは約6kmであり、結合されている状態の光フィーダライン/同軸ドロップの長さの最高値は、好ましくは約20kmである。ODN18の光フィーダライン側は、6本のファイバでもって終結する。ただし、これらのファイバの数は可変である。上記の6本のファイバは、下りビデオフィーダライン42（ビデオスプリッタ38から通ずる単一のファイバ）と、下り電話フィーダライン24（下り電話トランスミッタ14から通ずるフィーダライン）と、下り電話保護用フィーダライン24（下り電話トランスミッタ14から通ずるフィーダライン）と、上り電話フィーダライン26（上り電話レシーバ16へ通ずるフィーダライン）と、上り電話保護用フィーダライン26（上り電話トランスミッタ16へ通ずるフィーダライン）と、スペアファイバ（図示されていない）とによって構成される。ODN18は、下り電話トランスミッタから通ずる受信用の光フィーダライン24上での保護を目的とした切り換え機能を提供する。また一方で、ODN18は、上り電話レシーバへ通ずる上り光フィーダライン26上で冗長性の送信を提供する。ここでは、上り光フィーダライン上での保護は、上り電話レシーバ16にて制御される。ODN18の同軸分散側において、このODN18は、最大4つの同軸脚部30でもって終結する。

下り方向において、ODN18は、光の下り電話信号を電気信号に変換する下り電話レシーバ402を有している。さらに、ODN18は、下り電話レシーバ402からの電気信号と、下りビデオレシーバ400からの変換後の下りビデオ信号とを結合させるブリッジヤ-増幅器403を有している。ここで、下りビデオレシーバ4

00は、VHDT34から通ずるODN18にて終結する。下りビデオレシーバ400にて結合した広帯域の電話/ビデオ信号は、さらに、下り伝送用に割当てられたスペクトル内で転送される。例えば、このスペクトルは、HFCの分散ネットワークにおける同軸部分の4つの脚部の各々において725~800MHzの帯域を有する。このようにして、上記の電気的な電話信号およびビデオ信号は

、4つの同軸部分の脚部を通過して複数のISU100に伝送される。さらに、ブリッジャー増幅器403は、4種の下りの電氣的な電話信号およびビデオ信号を複数のダイプレックスフィルタ406にそれぞれ印加する。2つの異なる周波数帯域内で、それぞれ上り伝送用および下り伝送用として信号が使用される場合、上記のダイプレックスフィルタ406は、送信機能および受信機能を分離することによって完全な二重動作を可能にする。ODN18にて受信したときと同じ周波数帯域において、電話信号およびビデオ信号が、ODN18を通過した後にHFCの分散ネットワーク11の同軸部分を介して遠隔のユニット46に達したときには、ODN18にて周波数変換を実行することはしない。図1に示すように、各々の同軸脚部30は、複数の同軸タップ44を介して、相当な数の遠隔のユニット46に対し下りの電氣的な電話信号およびビデオ信号を供給することができる。当業者にとって周知の同軸タップは、複数種の電気信号を両方向に取り込む動作をする受動素子の役目を果たす。各々の同軸脚部30はまた、直列に接続された多数の同軸タップを有することも可能である。さらに、HFCの分散ネットワーク11の同軸部分は、データがシステム10の同軸部分を通過して送られる距離を伸ばすために、任意の数の増幅器を使用することが可能である。下りの電氣的な電話信号およびビデオ信号は、さらに、一つのISU(図6)に供給される。より具体的にいえば、このIS

Uは、図1に示すようなHISU68またはMISU66である。

上り方向において、電話情報およびセットトップボックス情報は、5MHzから40MHzまでのRFスペクトル領域において、4つの同軸脚部30を通過した後にODN18内のダイプレックスフィルタ406により受信される。ODN18は、4つの同軸脚部30中の最高3つの同軸脚部に設けられた選択的な周波数シフタ64を有することが可能である。上記ODN18はまた、もし使用する予定があるならば、一つの同軸脚部上の上りスペクトルを他の3つの同軸脚部と混合する前に、上記の一つの同軸脚部上の上りスペクトルと、この上りスペクトルより高い周波数とを混合することも可能である。周波数シフタ64は、上りスペクトルを50MHzの任意の倍数の値に推移させるように設計される。例えば

、周波数シフト64は、RFスペクトルの5MHz～40MHzの部分にある上り情報と、次の周波数領域のいずれかとを混合するように設定される。すなわち、50MHz～100MHz、100MHz～150MHz、または150MHz～200MHzの周波数領域である。このことによって、上り情報がODN18内で結合したときでも、任意の同軸脚部30が他の脚部と何ら競合することなく、RFスペクトル内の他の脚部と同じ部分を使用することが可能になる。上記のような周波数シフト64の設定動作は、一つの同軸脚部30上で選択可能である。ODN18はまた、結合器408を有している。この結合器408は、全ての同軸脚部30（同軸脚部30は、周波数シフトがなされているかもしれないし、あるいは、まだなされているかもしれない）からの上りの電気的な電話情報およびセットトップボックス情報を結合させることによって、4つの同軸脚部30の各々に存在する全ての上り情報を含む一つの複合の上り信号を生成するためのものである。このような複合の電気的な上り信号は、

受動的に1：2分割により分割される。さらに、各々の上り信号は、上りのファブリーペロー式レーザ送信器に供給される。さらに、このファブリーペロー式レーザ送信器は、上り電話レシーバ16に上り信号を伝送するために、対応する上りファイバフィードライン26を駆動する。

もし、上りの電話情報およびセットトップボックス情報が、ODN18においてより高い周波数領域に推移するならば、上り電話レシーバ16は、ODN18にて生ずる高い周波数領域へのシフト量に従って信号をより低い周波数領域に推移させるための周波数シフト31を備えている。カプラー33は、さらに、より低い周波数領域に推移した全ての信号を結合させることによって、この結合した状態の信号をHDT12に印加するようにしている。ODN18にて信号がより高い周波数領域に推移する場合にのみ、上記のような信号のより低い周波数領域へのシフトおよび信号の結合が用いられる。

#### 統合サービスユニット (ISU)

図1に示すように、HISU68およびMISU66のような複数のISU100は、HFCの分散ネットワーク11と、遠隔のユニット46に対する顧客サ

サービスとの間のインタフェースを提供する。ここでは、特定の顧客にサービスを提供するような2つのタイプのISUが例示されている。マルチユーザ統合サービスユニット66(MISU)は、マルチ住宅統合サービスユニットかまたはビジネス統合サービスユニットであることも可能である。このマルチ住宅統合サービスユニットは、居住環境と事業所の環境とを組み合わせられた環境に対して使用することも可能である。例えば、多数の居住者が住むビルディングや、複数の小さな事業所や、一群の住居等の環境が考えられる。これらの環境に関わる顧客は、わかりやすく

且つ経験豊富な電話サービス(POTS)や、データサービスや、DSIサービスや、標準のTR-57サービスのような複数種のサービスを要求する。複数のビジネス統合サービスユニットは、事業所の環境のサービスを実行するように設計される。これらのビジネス統合サービスユニットは、データサービスや、ISDNや、DSIサービスや、ビデオ相談等のような比較的高い周波数帯域のサービスをも要求することがあり得る。住居統合サービスユニット68(HISU)は、一人の居住者が住むビルディングのような居住環境や、意図されたサービスが、POTSと、基本的な等級である統合デジタルサービスネットワーク(ISDN)であるような2階建てアパートのような居住環境に対し使用される。本発明に関する限り、マルチ住宅統合サービスユニットと事業所統合サービスユニットとは同じような機能を有しているので、ここでは説明を簡単にするために、上記のISUに関する記述をHISUとMISUに限定することとする。

全てのISU100は、RFモデムの機能を遂行し、一般的には図6のISU100により示される。このISU100は、ISUモデム101と、コアックススレーブコントローラユニット(CXSU)102と、顧客サービスインタフェースを提供するチャンネルユニット103と、ダイプレックスフィルタ/タップ104とを有している。下り方向において、下りの電気的な電話信号およびビデオ信号は、ダイプレックスフィルタ/タップ104に印加される。HISUが使用される場合、このダイプレックスフィルタ/タップ104は、電話情報をISUモデム101に渡すと共に、イングレスフィルタ105を介してビデオ情報を

ビデオ機器に渡す。ISU100がMISU66である場合、ビデオ情報はダイブックスフィルタにより取り除かれる。ISUモデム101は、MCCモデム

82に対応する一つのモデムを利用して下り電話情報を復調する。ここで、MCCモデム82は、HDT12の直交マルチキャリアでもって上記の下り電話情報を復調するために用いられるものである。ISU100はまた、一時的に設定された6MHzの周波数帯域において、同軸分散脚部30からの下り電話情報を復調する。ISUモデム101内のタイミング生成107は、CXSU102に対し基準となるクロックを提供する。ここで、CXSU102は、各種の処理を規定すると共に、ISUモデム101による受信および送信を制御する。ISUモデム101から復調されたデータは、提供されるサービスに応じて、利用可能なチャンネルユニット103に送られる。例えば、チャンネルユニット103は、POTS、DSIサービス、ISDN、およびその他のデータサービス等を実行するためのラインカードを備えることが可能である。各々のISU100は、6MHzの周波数帯域にて利用可能な全てのチャンネルの中で、HDT12内の複数のCXMUの一つに対応する固定されたサブセットに対するアクセスを実行する。このようにしてアクセスがなされたチャンネル中のサブセットは、ISU100の種類に応じて変化する。MISU66は、6MHzの周波数帯域において、多数のDSOチャンネルに対するアクセスを実行することも可能である。また一方で、HISU68は、2～3のDSOチャンネルに対してのみアクセスを実行することができる。

チャンネルユニット103は、電話情報を提供すると共に、CXSU102へ送られるデータを制御する。ここで、CXSU102は、上記データをISUモデム101に供給すると共に、一時的に設定された6MHzの周波数帯域において、上記の電話データおよび制御データを変調するために、ISUモデム101に接続された同軸分散脚部30上で上記ISUモデム101を制御する。ISUモ

デム101によりHDT12への送信を行うために一時的に設定された上りの6MHzの周波数帯域は、HDT12内のCXMU56による送信に使用される複

数の下りの6MHzの周波数帯域の一つに対応する。

CXSU102は、ISUモデム101から復調されたデータを、利用可能なチャンネルユニットに印加するものである。さらに、このCXSU102は、ISUモデム101から受信された下り10ビットのDSO+パケット上で、データの完全性のチェックを実行する。下り10ビットのDSO+パケットの各々は、後述するように、パリティビットまたはデータインテグリティビットを含む。CXSU102はまた、下り10ビットのDSO+パケットの各々を受信する度に、下り10ビットのDSO+チャンネルの各々のパリティをチェックするであろう。さらに、チャンネルユニット103から受信した各々の上りDSO+のパリティが算出される。さらにまた、上りデータのエラーをHDT12によりデコードして識別するために、各々の上りDSO+の10番目のビットとしてパリティビットが挿入される。もし、CXSU102が受信した下り10ビットのDSO+チャンネルのパリティをチェックしたときに、CXSU102によりエラーが検出されたならば、下り方向にパリティエラーが生じたことをHDT12に知らせるために、対応する上りチャンネルのパリティビットが意図的に逆転される。それ故、上りパリティビットは、下りDSO+チャンネルと、この下りDSO+チャンネルに対応する上りDSO+チャンネルにてエラーが生じたことを示すことになる。上記のようなパリティビットを生成するためのプロセスの例が、「1対多の動作監視および障害分離システム」というタイトルであって譲受人に譲渡された米国特許出願（出願番号08/074,913）にて記述されている。このような上りパリティビット

は、さらに後述するように、チャンネル監視に利用される。当業者にとって明らかなことではあるが、パリティチェックおよびパリティ生成は、少なくとも一部において、ISU内の他の構成要素、または、チャンネルユニット等の上記構成要素に関連する別の構成要素により実行される。

各々のISU100は、エラーが生じた下り送信の同期を復帰させ、ISU100のデータ伝送に必要な全てのクロックを生成し、さらに、これらのクロックをそれぞれ関連するHDTタイミングにロックする。ISU100はまた、顧客

のライン起動状態およびライン休止状態を検出するために必要な機能の呼び出し処理を実行し、且つ、これらの状態の表示をHDT12に伝達する。さらに、ISU100は、HDT12からの制御データを終結し、且つ、受信する。さらにまた、ISU100は、HDT12から受信された制御データを処理する。この制御データの処理には、通信システム10におけるダイナミックチャネルの割当てを調整するためのメッセージが含まれている。最終的に、ISU100は、HFCの分散ネットワーク11にて受信されるパワー信号に基づいてISU動作電圧を生成する。このようなパワー信号として、ダイプレックスフィルタ/タップ104から得られるパワー信号109が例示されている。

#### HDTにおけるデータパス

ホストデジタルターミナル(HDT)12におけるデータパスに関する詳細な検討結果を次に述べることとする。図3に示すように、ネットワークインタフェース62におけるネットワーク装置と、下り電話トランスミッタ14との間のデータパスは、下り方向において、それぞれ、HDT12内のDSIU48、CTSUSU54およびCXMU56のモジュールを通過して進んでいく。HDT12内

の各々のDSIU48は、ネットワークから4つのDSIを受け取り、このようにして受け取った情報をフォーマット化することによって、24チャンネルからなる2.56Mbpsの4つの修正されたDSO信号のデータの流れを生成する。このようなデータの流れは、CTSU入力76と呼ばれるものである。CTSU入力の各々のDSOは、マルチフレームのタイミング信号の情報と制御/ステータスメッセージ(図7A)を伝達する9番目のビットを付加することによって修正される。9番目のビット信号(NBS)は、各々のフレームに対し更新され、24フレーム毎に繰り返すようなパターンを伝達する。このパターンは、ネットワークからの各々64kbpsのDSOを、72kbpsのDSO+にマッピングする。このようにして、各々のDSIにて利用可能な24個のDSOチャンネルが、全体の情報と共にフォーマット化され、4つのCTSU入力の各々にて24チャンネルのDSO+チャンネルが生成される。

9番目のビット信号(NBS)は、マルチフレームのタイミング、帯域外であ



ることを知らせるための信号ビット、種々雑多な状態、および、DSIUとチャンネルユニットとの間の各々のDSOに関連した制御情報を伝達するために考え出されたメカニズムである。上記9番目のビット信号の主な機能は、上記の信号ビットをチャンネルユニット103に伝達し、このチャンネルユニット103に対しマルチフレームクロックを供給することである。このような機能によって、マルチフレーム内の正しいフレームのDSOに上りビットの信号を挿入することができるようにしている。下りDSOは、同じマルチフレーム位相を共有しないようなDSIからやって来るので、各々のDSOは、DSIの開始に関連した信号フレームを示すマルチフレームクロックまたはマーカを持たなければならない。NBSは、このようなマルチフレームクロックまたはマーカを持つ能力

を提供する。9番目のビット信号は、通信システム11のOFDMモデムのトラnsポートに対しては透明である。

単一のHDT12には、7つのアクティブDSIU48と、1つの保護用のDSIUモジュール50とを含むような最大8つのDSIU48が設けられる。この場合、DSIUとCTS U54との間に32個のCTS U入力が接続されるけれども、最大28個のCTS U入力が、一度にトラフィックを行う際に利用できる。残りの4つのCTS U入力は、保護用DSIUに関連しているか、または、故障したDSIUに関連している。PSTUは、故障したDSIUを保護用のDSIU50に切替えるための切替制御の機能を有している。

各々のCTS U入力は、最大32個の10ビットチャンネルを伝達することが可能である。最初の24チャンネルはDSO+を伝達し、残りの帯域は使用されない。各々のCTS U入力76は、2.56Mbpsにてクロック設定がなされ、8kHzの内部フレーム信号に同期する(図7C)。この2.56Mbpsの値は、125μsecにつき320ビットのフレーム周期に対応する。これらの320ビットに対しては、図7Aに示すようなフレーム設定がなされる。フレームの開始時における14ビットのギャップビット72は、2番目のビット位置における単一のアクティブパルスのみを伝達し、残りの13ビットは、使用されない。288ビットの中で、最初の216ビットは、通常、24個のDSO+チャンネル

を伝達する。この場合、各々のD S O +チャンネルは、7 2 k b p s ( 8 k H z のフレーム毎に9ビット)の帯域を有している。残りの7 2 ビットは、付加的なD S O +パイロードチャンネルとして取っておかれる。フレームの最後の8ビット7 4 は、使用されないキャップビットである。

H D T 1 2 のクロックおよびタイムスロット交換ユニット5 4 ( C T S U ) は、最大2 8 個のアクティブC T S U 入力データの流れ7 6 からの情報を受け取り、これらのC T S U 入力データの流れ7 6 と、最大2 4 個の3 2 チャンネルからなる2 . 5 6 M b p s の出力データの流れ7 8 との切替接続を行う。ここで、出力データの流れ7 8 は、H D T 1 2 のコアックスマスタユニット ( C X M U ) 5 6 に入力される。C T S U 5 4 とC X M U 5 6 との間のデータの流れのフォーマットは、C T S U 出力とよばれる。各々のC T S U 出力はまた、C T S U のような最大3 2 個の1 0 ビットのチャンネルを伝達する。最初の2 8 個のチャンネルは、信号を伝達するが、残りの帯域は使用されない。各々のC T S U 出力は、2 . 5 6 M b p s にてクロック設定がなされ、H D T 1 2 の8 k H z の内部フレーム信号に同期する ( 図7 C ) 。この2 . 5 6 M b p s の値は、1 2 5  $\mu$  s e c につき3 2 0 ビットのフレーム周期に対応する。このようなフレーム構成は、前述したようなC T S U 入力の構成と同じである。

H D T 1 2 は、1 / 4 D S O パケット ( 1 6 k b p s ) を時間的および空間的に操作する機能を備えている。このような機能は、C T S U 5 4 の一部であるタイムスロット交換ロジックにより遂行される。この場合、C T S U は、4 0 9 6  $\times$  4 0 9 6 の1 / 4 D S O 切替接続機能を遂行する。ただし、必ずしも全てのタイムスロットが使用されるわけではない。通常の動作においては、C T S U 5 4 は、各々が2 4 D S O + からなる2 8 個のC T S U 入力として配置された最大6 7 2 個の下りD S O + パケット ( すなわち、最大2 6 8 8 個の1 / 4 D S O パケット ) を組み合わせて再配置することによって、各々が3 2 のD S O + からなる2 4 個のC T S U 入力として配置された最大7 2 0 個の下りD S O + パケット ( すなわち、最大2 8 8 0 個の1 / 4 D S O パケット ) が生成される。

システムは、ネットワークインタフェースにおいて、最大672のDSO+パケットのスループットを有している。ただし、CTS U出力の全ての帯域が使用できるとは限らない。もし、CTS U内の“CTS U出力”側にて672以上のチャンネルが割当てられるならば、このことは、CTS U出力が集中的に利用されたことを意味する。

アクティブCTS U54からの8つのアクティブCTS U出力78を受信するために、各々のCXMU56が接続される。8つのCTS U出力は、2.56Mbpsにてクロック設定がなされ、各々のCTS U出力は、前述したような32のDSO+を伝達する。これらのDSO+は、さらに、CXMUにより処理され、各々のDSO+に対し10番目のパリティビットが付加されて10ビットのDSO+が生成される。これらの10ビットのパケットは、DSO、NBS（9番目のビット信号）、および、パリティビットまたはデータインテグリティビットを含む（図7B）。10ビットのパケットは、HFCの分散ネットワーク11上でISU100に向かって伝送されるデータである。

下りチャンネルの中で挿入される10番目のビット、即ち、データインテグリティビットは、ISUにてデコードされチェックされる。さらに、このデータインテグリティビットは、前述したような上りチャンネル中の対応するチャンネルに対するパリティビットを算出して生成するために使用される。このようにして生成された上りチャンネルのパリティビットは、下りチャンネルまたは上りチャンネルにおけるエラーを表示するものであり、これから述べるようなチャンネルの保護または監視を実行するために使用される。

上り方向において、HDTを通過する反対方向のパスは、実質的に、HDT12を通過する順方向のパスを鏡に写したようなもので

ある。例えば、10番目のビットはCXMU56にて処理され、CXMU56からCTS U54に転送される信号は、図7Aのフォーマットに従っている。

DSUのラウンドトリップディレイは、すべてのデータパスについて同じである。下りCTS U出力からCXMU56を通過し、さらに、HFCの分散ネットワークを通過してISU100に達し、さらに、ISU100からHFCの分散

ネットワークに戻ってCXMU56を通過し、最後に、CTSU54に戻るまでの時間的な遅延は、これから詳細に説明するように、上り同期によって制御される。一般的にいえば、バスにおける遅延は、各々のISUについて測定される。このようにして測定した遅延が、正しいフレームの数になっていない場合、ISUにおけるバスに適切な遅延を付加することによって遅延の長さが調整される。

コアックスマスタユニット (CXMU)

コアックスマスタユニット56 (CXMU) は、図3に示すように、コアックスマスタカードロジック80 (CXMC) と、マスタコアックスカード (MCC) モデム82とを有している。既述したように、単一のHDT12には、最大6つのCXMU56が設けられる。これらの6つのCXMU56は、3対のCXMU56を構成する。各々の対のCXMU56は、6MHzの帯域にて伝送するように規定されている。さらに、各々の対のCXMU56は、一つのアクティブCXMUと、スタンバイのCXMUとを含む。このようにして、各々のCXMUに対し1対1の保護が実現される。図3に示すように、各々の対の両方のCXMUに対し、上り電話レシーバ16からの上り電話データが供給される。両方のCXMU共、同軸ライン22を介して下り電話トランスミッタ14に伝送する能力を有する。この場合、1対1の保護を実現するために、一つの制御信

号のみが要求されるのみである。ここで、1対1の保護とは、各々の対の一方のCXMU56が送信または受信に使用されることを意味する。

コアックスマスタカードロジック (CXMC)

CXMU56のコアックスマスタカードロジック80 (CXMC) (図8) は、HDT12、特にCTSU54のデータ信号と、HFCの分散ネットワーク11上でデータをトランスポートするためのモデムインタフェースとの間のインタフェースを提供する。CXMC80は、MCCモデム82に対する直接のインタフェースとなる。CXMC80はまた、HDT12と、6MHzの帯域でサービス動作を行う全てのISU100との間で多対1の動作を行わせるためのISU動作チャネルトランシーバの機能を遂行する。ここで、CXMU56は、6MHzの帯域内でデータのトランスポートを制御する。図8に示すように、CXMC

は、コントローラおよびロジック84と、下りデータ変換88と、上りデータ変換90と、データインテグリティ92と、I/Oトランシーバ96と、タイミングジェネレータ94とを有している。

下りデータ変換88は、C T S U 5 4から送られる9ビットのチャンネルフォーマット(図7A)から10ビットのチャンネルフォーマット(図7B)への変換を遂行し、各々の下りチャンネルについてH F Cの分散ネットワーク11上でトランスポートされるデータインテグリティビットを生成する。この場合、データインテグリティビットは、奇数パリティを表している。さらに、下りデータ変換88は、少なくとも一つのF I F Oバッファを備えている。このF I F Oバッファは、下りC T S U出力にて存在する32のギャップビット72、74(図7A)を取り除くために使用され、且つ、コントローラおよびロジック84の制御の下で、10番目のデータインテ

グリティビットを各々のチャンネルに挿入するために使用される。上りデータ変換90は、少なくとも一つのF I F Oバッファを備えている。このF I F Oバッファは、各々の上りチャンネルに付加された10番目のビット(データインテグリティビット)を評価し、この評価結果として得られた情報をデータインテグリティ92に送り込む。さらに、上りデータ変換90は、10ビットのチャンネルのデータの流れ(図7B)から、再度C T S U 5 4にて使用するための9ビットのチャンネルフォーマット(図7A)への変換を実行する。このようなデータ変換は、コントローラおよびロジック84の制御の下で実行される。

このコントローラおよびロジック84はまた、H F Cのネットワーク11上で電話トランスポートを行うための呼び出し処理およびチャンネル割当てを管理する。さらに、コントローラおよびロジック84は、当業者にとって周知のT R - 3 0 3サービスや集中サービス等を提供するためにダイナミックタイムスロット割当てが使用されるようなモードにおいて、H F Cの分散ネットワーク11上でのトラフィックの統計学的処理を継続する。さらにまた、コントローラ84は、6 M H zの帯域において、チャンネルにて生ずるエラーの統計学的処理を継続する。ここで、C X M Uは、データをトランスポートし、全てのI S U動作チャンネル通

信に対するソフトウェアプロトコルを提供し、そして、対応するMCCモデム82に対する制御を実行する。

データインテグリティ92の回路は、上り変換回路90による各々の上りチャネルの10番目のビットの評価結果の出力を処理する。本発明のシステムでは、処理中に呼び出しを有するような予め規定されたチャネルに対してのみパリティが有効であることが保証される。ISUが休止状態になったときには、初期化され且つ活性化

したISUトランスミッタが停止するので、CXMCにより実行されるパリティの評価は必ずしも有効ではない。ここで検出されるパリティエラーは、上りチャネルにおける送信エラーか、または、上りチャネルに対応する下りチャネルにおける送信エラーのいずれかである。

CXMC80のISU動作チャネル(IOC)トランシーバ96は、コントローラおよびロジック84からのメッセージまたは制御データを保持するための送信バッファを有している。さらに、ISU動作チャネルトランシーバ96は、全体で8バイトの固定された長さを有する制御メッセージを、HFCの分散ネットワーク11上でのトランスポートを行うためのMCCモデム82に設けられた64kbpsのチャネル内にロードする。上り方向において、IOCトランシーバは、MCCモデム82を介して64kbpsのチャネルを受信する。ここで、MCCモデム82は、コントローラおよびロジック84に上記メッセージを供給する。

タイミングジェネレータ94は、HDT12内のアクティブCTS U54および保護用CTS U54の両方から送られる冗長性のシステムクロック入力を受信する。このようなシステムクロックは、2kHzのHFCマルチフレーム信号を含む。このHFCマルチフレーム信号は、HFCの分散ネットワーク内の全ての同軸脚部におけるラウンドトリップ遅延の同期をとるために、CTS U54により生成される。上記のHFCマルチフレーム信号は、ISU動作チャネル上のマルチフレームのアラインメントを表示すると共に、シンボルタイミングとトランスポートシステムのためのデータ再構築との同期をとるために使用される。CT

S U 5 4 から C X M U 5 6 へ送られる 3 2 チャンネルの 2 . 5 6 M H z の信号の最初の“ギャップ”ビットを表示するために、8 k H z のフレーム信号が供給され

る。S C N U 5 8 および C X M U 5 6 に供給するために、C T S U 5 4 により 2 . 0 4 8 M H z のクロックが生成される。C X M U 5 6 は、I S U 動作チャンネルや、C X M C 8 0 と M C C モデム 8 2 との間のモデム通信のために上記クロックを使用する。D S I U 4 8 と C T S U 5 4 との間のデータ信号の転送、および、C T S U 5 4 と C X M C 5 6 との間のデータ信号の転送のために、2 . 5 6 M H z のビットクロックが使用される。C X M C と M C C との間の 1 0 ビットデータチャンネルの転送のために、2 0 . 4 8 M H z のビットクロックが使用される。

#### マスター・コアックス・カード (MCC) モデム

C X M U 5 6 のマスター・コアックス・カード (MCC) モデム 8 2 は、H F C 分散ネットワーク 1 1 から送信及び受信するため、C X M C 8 0 に対する一方側と電話トランスミッター 1 4 とレシーバ 1 6 に対する他方側をインタフェースする。M C C 8 2 は、電話データと制御データの O F D M トランスポートのためにモデム機能を実行する。図 3 のブロックダイアグラムは、上り及び下り通信の両者のために M C C の関連した相互接続を識別する。M C C モデム 8 2 は、C X M U 5 6 の C X M C 8 0 を介して以外 H D T 1 2 に対するインタフェースを持っていないので、H D T 1 2 において独立モジュールではない。M C C モデム 8 2 は、H D T 1 2 のトランスポートシステムロジックを表す。このように、それは H F C 分散ネットワーク 1 1 上で情報トランスポートと関連したすべての要件を実行するため責任を有する。H D T 1 2 の C X M U 5 6 の各 M C C モデム 8 2 は、電話データと制御データトランスポートのための下りスペクトルにおいて 6 M H z の最大バンド幅を割られる。6 M H z バンドの正確な位置は、C X M C 8 0 と M C C モデム 8 2 の間の I O C トランシーバ 9 6 を介して通信インタフェース上で C X M

C 8 0 により暫定的なものとする事ができる。電話及び制御データの下り送信は、約 7 2 5 から 8 0 0 M H z の R F スペクトルにある。各 M C C モデム 8 2 は

、約5から40MHzのRFスペクトル内でISUから制御データと電話データを受けするため、上りスペクトルにおいて最高6MHzを割当られる。再び、6MHzバンドの正確な位置は、CXMC80とMCCモデム82の間の通信インタフェース上でCXMC80により暫定的なものとする事ができる。

MCCモデム82は、上記記載のように20.48MHzの信号の形でCXMC80から256DS0+チャンネルを受ける。MCCモデム82は、すでにここで議論したように、OFDMに基づくマルチキャリア変調技術を用いてこの情報をすべてのISU100に伝送する。MCCモデム82は、HFC分散ネットワーク上で上り伝送の256DS0+マルチキャリアチャンネルを回復し、この情報をCXMC80を通過する20.48Mbpsストリームに変換する。前に記載したように、マルチキャリア変調技術は、直交位相振幅変調によるような、電話及び制御データをシンボルにコード化し、直交マルチキャリアのセット上の電話と制御データを変調するため、逆高速フーリエ変換技術を実行する。

シンボル整列は、ISU100のMCCモデム82及びISUモデム101により実行されるマルチキャリア変調技術のために必要な要件である。伝送の下り方向において、ISU100のすべての情報は、単一のCXMU56で発生し、各マルチキャリア上で変調された記号は自動的に位相整列する。しかしながら、MCCモデム82のレシーバにおける上りシンボル整列は、HFC分散ネットワーク11の多対点性及びISU100の等しくない遅延経路のために変化する。MCCモデム82での受信効率を最大にするため、す

べての上り記号は、狭い位相マージン内に整列しなければならない。これは、異なったISU100から上りを受けたすべてのチャンネルのシンボル期間が、それらがHDT12に到達する点で整列するような各ISU100における調整可能な遅延パラメータを利用することによりなされる。これは上り同期プロセスの一部であり、以下に記載される。加えて、マルチキャリアの直交性を維持するため、ISU100による上り伝送のために用いられるキャリア周波数はHDTに対して周波数ロックされなければならない。

CXMC80からMCCモデム82に入ってくる下り情報は、MCCモデム8



2に提供される2kHz及び8kHzクロックにフレーム整列される。2kHzマルチフレーム信号は、以下に詳細に記載するように、ISUに下りシンボルタイミングを伝達するため、MCCモデム80により用いられる。このマルチフレームクロックは、ISU100で電話データを正確に組み立て直すことができるようにするため、チャンネル応答を伝達し、マルチキャリアフレーム構成を示す。2つのkHzは10kHz（モデムシンボル比率）と8kHz（データフレーム比率）の間の最も大きい共通要素を表す。

すべてのISU100は、ISU100に求められるすべての下りタイミングを回復するため、関連するMCCモデム82により挿入される同期情報を用いる。この同期はISU100が下り情報を復調することを許容し、HDT12で受けたすべてのISU100送信が同じ基準に同期される。このように、すべてのISU100上り伝送に用いられるキャリア周波数は、HDT12に周波数ロックされる。

シンボル整列は、経路遅延調整、初期化及び活性化を提供することに加え、MCCモデム82の責任の下で下りと上り6MHzの同

期チャンネル上で実行され、そして、初期化と活性化がここで記載されるように完成するまでこのような同期チャンネルに供給する。これらのパラメータはIOCチャンネルの使用により追跡される。システムの重要性のため、IOCチャンネルと同期チャンネルは、MMCモデム82と、より活発な又は電話データの伝達のために使われるより少ないISU100の間の制御データのトランスポートのために異なった変調スキームを用いることができる。例えば、電話データは直交位相振幅変調を用いて変調することができ、一方、IOCチャンネルと同期チャンネルは、BPSK変調技術を利用することにより変調できる。

MCCモデム82は、ISU100によりマルチキャリア上で変調された電話データと制御データを復調する。このような復調は、電話トランスポートシステムの種々の実施例について以下に記載される。

MCCモデム82が責任を有するOFDMトランスポートシステムに関する機能は、少なくとも以下のものを有し、それらは更に詳細に種々の実施例に関し記

載されている。MCCモデム82は、同期チャンネル内のISUから同期パルス／パターンの受信した振幅／レベルを検出し、このレベルの表示をそれらの間の通信インタフェース上でCXMC80に通す。CXMC80は、その振幅レベルの調整のために均一化されたISU100に伝送のため、MCCモデム82にコマンドを提供する。MCCモデム82は、既知のシンボル境界に関し同期チャンネル上で変調された上りパターンを相関させ、そしてその間の通信上でCXMC80に対する必要なシンボル遅延訂正を通過させることにより、すべての上りマルチキャリアのシンボル整列のために備える。CXMC80は、MCCモデム82を介し、ISU100のシンボルを調整するため、ISU100

に下るメッセージを伝送する。全体的な経路遅延調整のためISU100を同期することに関し、MCCモデム82は、既知の基準境界に関しIOCチャンネル上でISU100により適当なバンド幅で変調された上りマルチフレームパターンを相関させ、そしてそれらの間のモデムインタフェース上でCXMC80に対する必要な経路遅延訂正を通す。CXMC80は、ISU100の全体の経路遅延を調整するため、IOC100チャンネル上でMCCモデム82を介し、メッセージを下りに伝送する。

#### 二方向性多対点電話トランスポートの概要

以下はHFC分散ネットワーク上11上の電話と制御情報のトランスポートをまとめたものである。HDT12の各CXMU56が、その特定の上りと下りの動作周波数に関し供給される。CXMU56による上りと下りの伝送の帯域幅は、約725-800MHzのRFスペクトルの6MHz帯域の下り伝送で最高6MHzである。

下り方向において、CXMU56の各MCCモデム82は、暫定的6MHz帯域幅で同軸ライン22を介して、下り電話トランスミッター14に電氣的な電話及び制御データ信号を提供する。HDT12のMCCモデム82からのRF電氣的な電話と制御データ信号は、合成信号に結合される。下り電話トランスミッターは、結合された電氣信号を、一対の保護された下り光ファイダライン24上で変調のため冗長な電氣-光変換器に通す。

下り光フィーダライン24は、電話情報と制御データをODN18に運ぶ。ODN18で、光信号は電気信号に変換され、下りビデオ情報（ビデオヘッドエンド供給ライン42から）と結合され電気の下りRF出力信号になる。電話情報と制御データを含む電気のRF出力信号は、ODN18により4つの同軸分散脚30に供給され

る。電話情報と制御データ下りは、各同軸脚部30に分散され、HFC分散ネットワーク11の同軸部分上で運ばれる。電氣的な下り出力RFは、同軸ケーブルからタップに接続され、図6に示すディプレックスフィルタ104を通してISU100の受信モデム101上で終わる。

RF電気出力信号は、直交周波数分割多重化技術を利用してMCCモデム82により、直交マルチキャリア上で変調された電話情報と制御データを有している。電話情報と制御データはシンボルデータにマップされ、シンボルは高速フーリエ変換技術を用いて複数の直交キャリア上で変調される。シンボルは、すべてシステム11の多数ポイントに伝送される単一のポイントでキャリア上で変調されるので、マルチキャリアの直交と直交マルチキャリア上で変調されたシンボルのシンボル整列は、自動的にHFC分散ネットワーク上でトランスポートのために整列し、そして、電話情報と制御データは、モデム101によりISUで復調される。

ISU100は、HFCネットワーク11の同軸部分の同軸ケーブルからタップを取ったRF信号を受ける。ISU100のRFモデム101は、信号を復調し、適切にチャンネルユニット103に供給のためCXSU制御器102に抜き出された電話情報と制御データを通す。ISU100は、電話情報が加入者又は顧客が使うために変換されるインタフェースを表す。

HDT12のCXMU56とISU100は、通信システム10の二方向性多対点電話伝送システムを実行する。CXMU56とISUは、それゆえ、モデム機能を実行する。本発明によるトランスポートシステムは、トランスポートシステムのためのモデム機能性を実行するため3つの異なるモデムを利用することができる。第1のモデムはHDT12の各CXMU56に配置されたMCCモデ

ム82である。例えば、HDT12は、アクティブMCCモデム82（図3）を有し、多対点トランスポートネットワークを表す多くのISUをサポートすることができる。MCCモデム82は、HDT12によりISUを制御するため制御データトランスポートと同じく電話情報トランスポートを調整する。例えば、制御データは、呼出し処理メッセージ、ダイナミック配分及び割当メッセージ、ISU同期制御メッセージ、ISUモデム制御メッセージ、チャンネルユニット供給、及び他のISU操作、管理、維持、供給（OAM&P）情報を有することができる。

第2のモデムは、単一家族の加入者又は単身居住住居ユニットをサポートするために最適のHISUモデムである。そのため、コストが低く、電力消費は少ない。第3のモデムは、多数加入者又はMISUモデムであり、それは一般に住居及びビジネスサービスの両方をサポートすることが求められている。

HISUモデム及びMISUモデムは幾つかのフォームをとることができる。例えば、HISUモデム及びMISUモデムは、本発明の種々の実施例に関して以下に詳細に記載されるように、HDT12から伝送されるマルチキャリアの小さな部分又はHDT12から伝送されるマルチキャリアのより大きな部分のみを取り出すことができる。例えば、HISUはHDT12からトランスポートされた電話情報の20マルチキャリア又は10ペイロードチャンネルを抜き出すことができ、MISUはHDT12からトランスポートされた260マルチキャリア又は130ペイロードチャンネルからの情報を抜き出すことができる。これらモデムの各々は、HDT12によりトランスポートされた信号から制御データを取り出すため分離した受信部分、及びHDT12からトランスポートされたマルチキャリア上で変調された電話情報を取り出すためのHISUモデム

の追加のレシーバ部分を用いることができる。これは帯域外ISUモデムとして以下に参照される。帯域外ISUモデムとともに用いるMCCモデム82は、直交キャリア波形内又は直交キャリアからいくらかオフセットしたキャリア上で制御情報を変調することができる。帯域外ISUモデムに対して、HISU及びMISUモデムは、ISUモデムのために単一レシーバを利用することで、単一

レシーバのモデムを利用するため電話情報と制御データの両者を取り出すことができる。これは、帯域内ISUモデムとして以下に参照される。この場合、制御データは直交キャリア波形内のキャリア上で変調されるが、しかし、異なったキャリア変調技術を利用することができる。例えば、キャリア上で制御データの変調のためのBPSKはQAM技術によるペイロードキャリア上の電話データと反対である。加えて、異なった変調技術は、制御データと電話データのための上りと下りの伝送に用いることができる。例えば、下り電話データは256QAMを利用することによってキャリア上で変調でき、下り電話データは32QAMを利用することによりキャリア上で変調できる。変調技術が伝送に利用されるものなんでも、何の復調アプローチがトランスポートシステムの受信端で用いられるかを規定する。HDT12からトランスポートされた下り電話情報と制御データの復調は、異なったモデムの実施例のブロックダイアグラムを参照して更に詳細に以下に説明する。

上り方向において、ISU100での各ISUモデム101は、約5から40MHzのRFスペクトルの6KHz帯域幅で少なくとも一つの直交マルチキャリア上で上に伝送する。上り6MHz帯域は、伝送が受信される下り6MHz帯域に対応する。上りの電気の電話及び制御データ信号は、図1に示されているように、ISUモデム101により、個々の同軸ケーブル脚30を介してそれぞれ

接続された光分散ノード18にトランスポートされる。ODN18で、種々のISUからの上り信号は、結合され、光ファイダライン26を介してHDTに光学的に伝送される。前に検討したように、種々のISUからの上り電気信号は、一部分、結合され合成上り光信号になる前にシフトした周波数かもしれない。このような場合、電話レシーバ16は対応する下りシフトした電気回路を有する。

多数ISU100から単一HDT12へのHFC分散ネットワーク上の伝送の多対点性により、直交周波数分割多重化技術を利用するため、ISU100により各キャリア上で変調されるシンボルは、一定の位相マージン内で整列しなければならない。加えて、以下にさらに詳細に検討されているように、通信システムにおけるHDT12のネットワークインタフェース62からすべてのISU10

0へ、そしてISU100からネットワークインタフェース62への一周経路の遅延を等しくしなければならない。マルチフレームの完全さをシグナリングすることがこのシステムを通して保持されるためこれは必要である。加えて、適当な振幅の信号は、ISU100に関し制御機能を実行するため、HDT12で受信されなければならない。同様に、ISU100からOFDMトランスポートに関し、ISU100は、HFC分散ネットワーク11上でトランスポートされたマルチキャリアが直交して整列するようにHDTに周波数ロックされなければならない。トランスポートシステムは、以下に記載するように、直交周波数分割多重化を利用してこの多対点伝送を実行するための分散されたループ技術を実行する。HDT12が直交的に整列しそして整列したシンボルとその上に変調された電話及び制御データを持つ複数のマルチキャリアを受けた時、CXMU56のMCCモデム82は、対応する6MHzで複数のマルチキャリアからの電話情報と制御データを復調し、ネットワークインタフ

ェース62に配達するためCTS U54に電話データを、そして電話トランスポートの制御のためCXMC80に制御データ提供する。この分野の当業者であれば気がつくように、設計上の選択であるスペクトル配分、周波数割当、データ比率、チャンネル数、提供されるサービスのタイプ、及びシステムの他のパラメータ又は特性は、単に例として取り上げたものである。添付された請求の範囲に記載された発明は、このような設計上の選択を予期しており、それらはそのような請求の範囲の範囲内に含まれる。加えて、多くの機能がソフトウェア及びハードウェアにより実行することができ、参照されるものが一つ又は他方であったとしても、どちらかの実行が請求の範囲に基づいて予期できるものである。

#### 電話トランスポートシステムの第1の実施例

本発明による電話トランスポートシステムの第1の実施例は、MCCモデム82、及び一般に図6においてISUモデム101として示されたHISUモデムとMISUモデムのブロックダイアグラムを有する図9-23を参照して個別に記載する。このようなモデムは、上りと下りのモデムトランスポート機能性を実行する。以下の記載はこのようなモデムを利用した動作の理論に関する検討であ

る。

図9Aを参照すると、OFDM技術を利用した電話情報と制御データの上りと下りのトランスポートのための一つの6MHz帯域のスペクトル配分が示されている。波形は好ましくは、19.2Mbpsのネットデータ比率に適應するための480キャリア又はトーンを有する240ペイロードチャンネル又はDSO+チャンネル、46キャリア又はトーンを有する24IOCチャンネル、及び2同期チャンネルを持っている。各同期チャンネルは、二つのキャリア又はトーンを有しており、ガードトーンとして利用される10の使用されて

いないキャリア又はトーンにより、24IOCチャンネル及び240ペイロードチャンネルから各々オフセットされている。キャリア又はトーンの総計は552である。更に以下に記載されるように、同期機能のために利用される同期トーンは6MHzスペクトルの端に位置しており、6MHz帯域の複数の直交キャリアは、6MHzスペクトルの各端でガード帯域(516.0KHz)により6MHz帯域に近いキャリアから分離されている。ガード帯域はシステムのトランスミッターとレシーバでフィルタ選択度のために許容する6MHz帯域の各端で提供される。同期キャリアは、もし初期化及び活性化の間に同期のために利用される同期キャリアが6MHz帯域内の他のトーン又はキャリアと直交していない場合、同期信号は直交的に整列した波形の構成を破壊するのを防ぐような電話データ又はペイロードキャリアからオフセットされる。同期トーンは、それ故、同期チャンネルは特別なIOCチャンネルと見なすことができるが、帯域のペイロードキャリア及び点在したIOCチャンネルの主体の外側である。

ISUのパワー要件を最小にするため、ISUが処理する帯域幅は最小化される。このように、電話ペイロードチャンネル及び6MHz帯域のIOCチャンネルは、10ペイロードチャンネル毎に位置しているIOCチャンネルと電話ペイロードチャンネルにおいて点在している。このような分散された技術で、10より大きいペイロードチャンネルのサブ帯域はIOCチャンネルを有しており、ISUが「合う」帯域幅の量はIOCチャンネルがISU100と通信するためHDT12のために利用可能であるよう制限される。図9Aに示されているスペクトル配分のための

このようなサブ帯域分散は図9Dに示されている。6MHz帯域幅に24のサブ帯域があり、各サブ帯域は5番目と6番目のペイロードチャンネルの間にI O Cチャンネルを持つ

た10ペイロードチャンネルを含んでいる。6MHz帯域を通してI O Cチャンネルを分散している利点は、狭い帯域進入(ingress)からの保護である。もし進入がI O Cチャンネルを破壊するならば、利用可能な他のI O Cチャンネルがあり、H D Tは6MHzの異なった部分にI S U 1 0 0を調節することができ、そこは壊れていないI O Cチャンネルが位置する。

好ましくは、M I S U 6 6は、帯域幅がH D T 1 2からM I S U 6 6に通信するため多数のI O Cチャンネルを含む130ペイロードチャンネルまで受信するため、6MHzの帯域幅のほぼ3MHzに合う。H I S U 6 8は、H D T 1 2で通信するため少なくとも一つのI O Cチャンネルを有する11チャンネルを受けるため、6MHz帯域幅の約100kHzを合う。

下りと上りの経路の間の第1の差は、下りの同期と上りの同期である。下り方向において、すべてのI S UはH D Tからの情報をロックする。I S Uの初期化と活性化は、上り同期チャンネルに供給される信号に基づいている。操作の間、I S UはI O Cチャンネルを介して同期を追跡する。上りにおいて、周波数制御は以下に記載されているように下り同期チャンネルのみを利用して提供することもできるが、上り同期プロセスは、振幅、周波数、及びタイミングの分散された(多対点)を含んでいる。上り同期のプロセスは、二つの上り同期チャンネルにおいて、第1の又は第2の同期チャンネルを生じる。

図10を参照すると、M C Cモデム82の下り伝送アーキテクチャーが示されている。およそ各々10Mbpsの二つの直列データ入力、8kHzフレームクロック入力によりクロックされているC X M C 5 6からのペイロードデータを有している。C X M C 5 6から入力されたI O C制御データはI O Cクロック入力によりクロ

ックされ、それは好ましくは2.0kHzである。電話ペイロードデータ及びI



OC制御データは、直列ポート132を通過して入り、該データは当業者に知られているように、HFC分散ネットワーク11上で伝送される波形のランダムさを提供するためにスクランブラー134によりスクランブルされる。スクランブルが無いと波形に大変高いピークが生じるが、しかし波形がスクランブルされると、MCCモデム82により発生されるシンボルは十分にランダムとなり、そのようなピークは十分制限される。スクランブルされた信号はシンボルマッピング機能136に加えらる。シンボルマッピング機能136は、入力ビットを取り、そしてそれらを複合星座点(complex constellation point)にマップする。例えば、入力ビットがBPSK信号の出力のためのシンボルにマップされた場合、各ビットは、図9CのBPSKのためのマッピングダイアグラムにあるように、星座の単一のシンボルにマップされる。このようなマッピングは、データとして同相で直交位相値(I/Q値)となる。BPSKは好ましくは上りと下りのIOCチャンネル及び同期チャンネルに使われる変調技術である。BPSKエンコーディングは、前に検討したシステムに活性を提供するため、IOC制御データのために好ましい。QPSK変調のため、すべての2ビットは星座点を表す4つの複合値の1つにマップする。好ましい実施例では、32QAMは電話ペイロードデータのために利用され、そこではすべての5ビットのペイロードデータは、図9Bに示されているように32星座点の1つに移される。このようなマッピングはI/Q値に帰着する。そのようなものとして、DSO+信号(10ビット)は、二つのシンボルで表され、二つのシンボルは二つのキャリアを用いて伝送される。このように、ひとつのDSO+チャンネルは二つのキャリア又は6MHzスペクトルのトーンにトランスポートされる。

当業者は、種々のマッピング又はエンコーディング技術が異なったキャリアで利用できることを認識している。例えば、ISDNを運ぶ電話チャンネルはQPSKを用いてコード化でき、反対にPOTSを運ぶ電話チャンネルは32QAMを用いてコード化される。そのため、異なったサービスを運ぶ異なった電話チャンネルは、このような品質を求めるこれらのサービスのためにより活性化した電話チャンネルを提供するため、異なって変調される。本発明によるアーキテクチャ

一は、異なるチャンネルに用いられる変調技術からいずれかのチャンネルを異なってコード化しそして変調するためフレキシビリティを提供する。I/Q値により表される各シンボルは、シンボルバッファ138の高速フーリエ変換(FFT)ビン(bin)に移される。例えば、8kHzフレームレートで動作しているDSO+として、5ビットが一つのFFTビンにマップされ、5ビットが別のビンに移される。シンボルバッファ138の各ビン又はメモリの位置は、I/Q値としての周波数ドメインのペイロードデータ及び制御データを表す。FFTビンの一つのオフセットは、当業者に知られている逆FFTを通してタイムドメインにマップされる。逆FFTは、複合I/Q値をFFTポイント数に対応したタイムドメインサンプルに移す。ペイロードデータとIOCデータの両者は、バッファ138にマップされ、そして逆FFT140によりタイムドメインサンプルに変換される。FFT140のポイント数は変化させることができるが、しかし、好ましい実施例ではポイント数は256である。256ポイントFFTのための逆FFT140の出力は、波形の256タイムドメインサンプルである。

逆FFT140は同相で直交位相(I/Q)の要素FFT1及びFFT0のための分離した直列出力を持っている。デジタル・アナログ・コンバータ142は、ベース帯域変調された信号の数の表

示である同相で直交位相の要素を取り、そしてそれを分離した波形に変換する。信号はそれから、調波の内容を取り除くために再構成フィルタ144を介して通る。この再構成は、多数ミキシングスキーム及び他のフィルタリング問題から生ずる問題を避けるために必要である。信号は、適用可能な伝送周波数に混合するため、同相及び直交位相要素とデジタル的に調整可能な合成された波形を利用してI/Q要素をアップ変換するため、変換トランスミッタ146において合計される。例えば、もしシンセサイザーが600MHzであれば、出力周波数は600MHzである。

要素は信号変換トランスミッタ146により合計され、複数の直交キャリアを有する波形は、電話トランスミッタ14により光ファイバー上に結合される前に、トランスミッター増幅器148により増幅され、トランスミッターフィルタ1

50により汙波される。このような機能は、このような変調を実行するために必要な一般的目的のプロセッサ149及びブロック47の他の処理回路の制御下で実行される。一般目的のプロセッサは、以下に記載されるように分散されたルーブシンボル整列、周波数ロック、振幅調整、及び経路遅延機能を実行するため、キャリア、振幅、タイミングリカバリーブロック222(図15)からのISU調整パラメータを受ける。

下り受信端において、MISU又はHISUの何れかは、6MHz帯域幅の一つにおいて下り伝送から電話情報と制御データを取り出すために提供する。MISU66に関し、MISU下りレシーバアーキテクチャーは図11に示されている。それは受信した600MHzから850MHzトータル帯域ブロードキャストの下りの周波数帯域を減少させるため、100MHz帯域通過フィルタ152を有する。汙波された信号は、帯域干渉を取り除き、そして更に帯

域幅を減らすため、電圧調整されたフィルタ154を通して通過する。信号は、直交位相及び同相ダウン変換器158を介してベース帯域周波数にダウン変換され、ダウン変換器158では信号は直列ポート178の出力から制御されるシンセサイザ157を利用した複合ミキサ156で混合される。ダウン変換されたI/Qは要素は、フィルタ159を介して通過し、そしてアナログデジタル変換器160でデジタルフォーマットに変換される。I/Q要素のタイムドメインサンプルは、サンプルバッファ162に置かれ、サンプルのセットはダウン変換器補償ユニット164に入力される。補償ユニット164は、ダウン変換器で生じるミキサ及び差動位相遅延からのDCオフセットのようなエラーを軽減することを試みる。

キャリア、振幅、及びタイミングシグナリングは、キャリア、振幅、及びタイミングリカバリーブロック166により、図22Aを参照して以下に記載するように、トラッキングの間のISUとIOCの初期化と活性化の間、同期チャンネルから制御データを取り出すことにより、補償信号から取り出される。平行なフォームの補償された信号は、MISUが合うDSO+チャンネルのためMCCモデム82で当初上りを創り出したI/Q要素を有した本質的に複合星座ポイントであ

る周波数ドメイン素子のベクトルに変換するため、高速フーリエ変換（FFT）170に供給される。チャンネルフィルタリングにおける不正確さのため、イコライザ172は送信及び受信の間に生ずるダイナミックエラーを取り除く。上りレシーバと下りレシーバにおける同等化し、図23を参照して以下に更に説明する。イコライザ172から、複合星座ポイントはスクランブラー134のミラー素子である復スクランブラー176で元にもどされるシンボル-ビット変換器174によりビットに変換される。そして、ペイロード電話情報とI/O制御データは直列ポート178により

図6に示されたCXSU102に出力される。ブロック153は、そこに示すように、種々の機能を実行するための処理能力を有している。

図12を参照すると、HISU68下りレシーバアーキテクチャが示されている。HISU下りレシーバアーキテクチャ（図11）とMISU下りレシーバアーキテクチャ（図11）間の第1の差は、処理される帯域幅の量である。FFT処理までのレシーバのフロントエンドは、ダウン変換の間、アナログデジタル変換器160が非常に遅く動作させられることを除き、実質的に同じである。例えば、もし処理される信号の帯域幅が100kHzであるなら、サンプル比率はおよそ200kHzである。MISU処理3MHz信号において、サンプル比率は約6MHzである。HISUは受信を最大10DS0+に制限しているので、FFT180はより小さなサイズにすることが出来る。A32ポイント180は、好ましくはHISUで用いられ、MISUで利用される128又は256ポイントFFTに比べてより効率的に実行できる。そのため、これらアーキテクチャー間の主たる差は、HISUレシーバアーキテクチャーはMISUレシーバより実質的により小さな処理能力を必要としており、より少ない電力消費となる。このように、リモートユニットでの電力消費を最小にするシステムを提供するため、HISUに合うより小さな帯域の周波数は、このように低消費を許容する。HISUがこのようなキャリアの小さな帯域に合うことを許容される一つの理由は、I/Oチャンネルが6MHzスペクトルを通して点在しているからである。

図13を参照すると、HISU68用の上りトランスミッタアーキテクチャが示される。CXSU102(図6)からのIOC制御データ及び電話ペイロードデータは、HISUにおいて、MISU

又はHDTトランスミッタアーキテクチャの場合よりもはるかに遅いレートでシリアルポート182に供給される。なぜなら、HISUは10本のDS0+チャネル分のみサポートするからである。HISU上りトランスミッタアーキテクチャは3つの重要な動作を実施する。それは、伝送された信号の振幅、伝送された信号の時間遅延(シンボル及びパス遅延)及び伝送された信号のキャリア周波数を調整する。電話データ及びIOC制御データは、HISU下りレシーバアーキテクチャのクロックジェネレータ173によって生成されたクロック信号の制御を受けてシリアルポート182に入り、そして、MCC下りトランスミッタアーキテクチャに関して上述した理由からスクランブラ184によってスクランブルされる。入力されるビットは、ビット対シンボルコンバータ186により、周波数領域においてI/Q成分を含むシンボル或いは複素群点にマッピングされる。次いで、群点はシンボルバッファ188に取り込まれる。バッファ188の後段には、逆FFT190が、シンボルに対応して時間領域でのサンプルすなわち32ポイントFFTに対応する32個のサンプルを生成するように接続されている。逆FFT190の出力側には、ディレイバッファ192が、HDT12によって制御される上り同期プロセスの関数として、MCCモデムの上りレシーバアーキテクチャにてマルチフレーム整列を提供するように接続されている。従って、ディレイバッファ192は、逆FFT190の出力の同相及び直交成分のデジタル/アナログコンバータ194によるデジタル/アナログ変換に先立って、パス遅延調整を行う。クロックディレイ196は、スクランブルされる前にシリアルデータストリームから制御データを抽出することにより得られるIOC制御データ出力の要求に基づいてシンボル整列のための微調整を行う。デジタル/アナログコンバータ194によるアナロ

グ成分への変換後、そのアナログ成分は、再生フィルタ198によって平滑なア

ナログ波形に再生される。次いで、上り信号は、ダイレクトコンバータ197により直接、シンセサイザブロック195の制御の下に適切なトランスミット周波数に変換される。シンセサイザブロック195は、I O C制御チャネルからのコマンドの制御を受けて動作する。このI O C制御チャネルは、H I S U下りレシーバアーキテクチャにおいて抽出されているのでキャリア周波数調整コマンドを提供する。次いで、変換された信号は、トランスミッタ増幅器200によって増幅され、トランスミッタフィルタ202によって濾波され、そして上り側に伝送されて、他のI S U 1 0 0によって伝送された他の信号と組み合わせられる。ブロック181はそれぞれの機能を実行するための処理回路を含む。

図14を参照すると、M I S U 6 6用の上りトランスミッタアーキテクチャが示され、H I S U 6 8用の上りトランスミッタアーキテクチャと実質的に同じである。しかしながら、M I S U 6 6は、より多くのチャネルを扱い、H I S U 6 8では可能であるところの単一のプロセッサ上での動作を実行することはできない。従って、逆F F T 1 9 1を含むブロック181の機能を提供するブロック181のプロセッサと、そのアーキテクチャをサポートする汎用プロセッサ206は共に、増えた分のチャネル容量を扱う必要がある。

図15を参照すると、H D T 1 2における各C X M U 5 6のM C C上りレシーバアーキテクチャが示される。5～40MHzのバンドパスフィルタ208は上り信号を濾波する。この上り信号は、ミキサ及びシンセサイザ回路211によるベースバンドへのダイレクトダウン変換を受ける。ダウン変換された出力は折り返し防止フィルタ201に入力され、そして、その出力信号はアナログーデジタルコンバータ212によってデジタル形式に変換される。各ア

ナログーデジタルコンバータ212は、信号の同相及び直交成分の時間領域でのサンプリングを行い、狭帯域イングレスフィルタ及びF F T 1 1 2に供給する。この狭帯域イングレスフィルタ及びF F T 1 1 2は、以下に記述するように、上り伝送に影響を与える可能性のある狭帯域干渉からの保護を提供する。

狭帯域イングレスフィルタ及びF F T 1 1 2は、一度に10チャネルを保護する。従って、もしもイングレスが、M C Cモデム82によって受信される6MH

zスペクトルにおいて使用可能な240本のDSO+sのうち1本に影響を与えたならば、最大10チャンネルがそのイングレスによって破壊されることになるであろう。狭帯域イングレスフィルタ及びFFT112は、通常のフィルタ技術として当業者には認識されるように、多相構造を有している。また、その多相フィルタによって保護されるチャンネルの数を変えることができることは当業者には認識されるであろう。狭帯域イングレスフィルタ及びFFT112の出力は、チャンネルにおいて発生する誤り、例えば基準オシレータ又はシンセサイザからのノイズに起因する誤り、を訂正するためのイコライザ214に供給される。イコライザ214の出力シンボルは、シンボル対ビットコンバータ216に供給され、そこでシンボルがビットにマッピングされる。ビットは、ISU100のスクランブラとはミラーの関係にあるデスクランブラ218に供給され、該デスクランブラの出力はシリアルポート220に供給される。シリアルポートの各出力は、下り方向のMCC下りトランスミッタアーキテクチャに供給されるように2つのペイロードストリームと1つのIOC制御データストリームに分割される。ブロック217は、それぞれの機能を実行するための必要な処理回路を含む。

下り情報を検出するためには、下り同期プロセスを用いて到来信

号の振幅、周波数及びタイミングを獲得しなければならない。下り信号は点对多点ノードトポロジーを構成するので、OFDM波形は、上り信号とは対照的に、本質的に同期した形態で単一のパスを介して到来する。波形パラメータの獲得は、まず、6MHzスペクトルの最終部分に位置する下り同期バンドにおける下り同期チャンネル上で行われる。これらの同期帯域は、2kHzのフレームクロックによってBPSK変調された単一の同期キャリア又はトーンを含む。このトーンは、ISUにおいて初期の振幅、周波数及びタイミングを抽出するのに用いられる。同期キャリアは、受信帯域の中心部分に位置してもよく、またIOCの特別なケースと見なすことができるであろう。信号が受信され、そのレシーバアーキテクチャが典型的なIOCチャンネルに調整された後、その同じ回路がIOCチャンネルを用いて同期パラメータを追跡するのに用いられる。

必要な信号パラメータを獲得するのに用いられるプロセスはISUレシーバア

アーキテクチャのキャリア、振幅及びタイミング再生ブロック166を利用し、該ブロックは図22Aにおいてブロック図の形でより詳細に示される。キャリア、振幅及びタイミング再生ブロック166は、受信波形に対して周波数ロックを行うのに用いられるC o s t a sループ330を含む。補償ユニット164から信号が受信されると、その信号はサンプルホールド334及びアナログ-デジタルコンバータ332に入力され、該コンバータ332から出力された信号はC o s t a sループ330に供給される。サンプリングは、電圧制御型オシレータ340の制御の下に、レシーバアーキテクチャで用いられるFFTのポイント数Mだけ分割を行うディバイダ333によって分割されるように、行われる。C o s t a sループ330のミキサ331は、到来信号とフィードバックパスの供給を受け、ループ位相検出器として機能する。ミキサ33

1の出力は、濾波されると共に、その後のハードウェアの処理量を低減するために $1/10$ 単位で処理される。もし受信信号が帯域的に制限されているならば、同期信号を表すのにそれ程多くのサンプルは必要としないであろう。もし直交性がレシーバにおいて保存されないならば、フィルタは所望としない信号成分を再生プロセスから除去するであろう。直交性があるという条件の下で、LPF337は隣合うOFDMキャリアからの影響を完全に除去することになる。キャリア周波数ロックが達成されると、ループの同相側において所望とするBPSK波形が出現する。デシメータの出力は別のミキサを介して供給され、 $H(s)$ のフィルタ関数を持つループフィルタ及び数値制御型オシレータ(NCO)を介して処理され、最終的に周波数誤差を訂正するためのフィードバックパスを構成する。誤差が「小さい」レベルにある時、ループはロックされる。追跡動作中に高速の獲得及び最小のジッタを達成するためには、デュアルループバンド幅を用いる必要があるであろう。システム動作は、OFDMチャンネル間隔(360Hz)の約 $\pm 4\%$ 以内で周波数ロックが達成され且つ維持されることを必要とするであろう。

信号の振幅は、BPSK電力検出器336における周波数再生ループの出力端で測定される。トータルの信号電力が測定され、そして、数値可変型アナログゲ



イン回路（図示せず）を調整するのに用いることができる。ゲイン回路は、アナログ-デジタルコンバータが最適な動作領域で用いられるように信号を正規化するためのものである。

タイミング再生は、タイミング誤差を抽出するための早-遅ゲート形位相検出器338の早-遅ゲート形アルゴリズムを用いて、さらに誤差信号に応答するサンプルクロックオシレータ340を調整することにより、行われる。早-遅ゲート形検出器は、更新間隔の

間に進み-遅れコマンドを出力する。このコマンドはフィルタ341を介してサンプルクロックオシレータ340に印加される。このループは、周波数のロック及び振幅のロックが達成されるまで保持される。タイミングループがロックされると、ロック指示信号が生成される。また、同じクロックは上り伝送用に用いられる。キャリア、振幅及びタイミング再生ブロック166は、クロックジェネレータ168用の基準信号を提供する。クロックジェネレータ168は、MISUが必要とする全てのクロック、例えば8kHzフレームクロック及びサンプルクロック、を提供する。

MCCモデム上りレシーバアーキテクチャ（図15）のキャリア、振幅及びタイミング再生ブロック222が、図22Bの同期ループ図によって示される。これは、上り同期チャンネル上の信号に関して上り同期のための検出を行う。ISUの初期化及び活性化のために、上り同期は、ISUの1つに対し下りIOC制御チャンネルを介して基準信号を同期チャンネルの上り側に送出するよう指令するHDTによって行われる。キャリア、振幅及びタイミング再生ブロック222は、同期チャンネルにตอบสนองし且つHDT12における基準信号に対する周波数誤差、振幅誤差及びタイミング誤差を評価するISU100からのデータのパラメータを測定する。キャリア、振幅及びタイミング再生ブロック222の出力は、HDT12によって調整コマンドに変換され、MCC下りトランスミッタアーキテクチャによってIOC制御チャンネル上の下り方向で初期化され且つ活性化されつつあるISUに送出される。

上り同期プロセスの目的は、別々のISUからの波形がHDT12で合わさっ

て統合波形となるように、ISUを初期化し且つ活性化することである。HDT 12においてキャリア、振幅及びタイミング再生ブロック222によって評価され、且つISUによって調

整されるパラメータは、振幅、タイミング及び周波数である。ISUの信号の振幅は、 $DS0+s$ が等しい量の電力を割り当てられるように正規化され、HDT 12において所望の信号対雑音比を達成する。更に、隣合うISUは正しい相対的なレベルで受信されなければならない。さもなければ、相対的に弱い $DS0+$ チャンネルは、相対的に強い $DS0+$ チャンネルの過渡的な振る舞いによって不利な影響を受けるであろう。もしペイロードチャンネルがかなりの周波数誤差を持つ別のペイロードチャンネルに隣接して伝送されたならば、OFDM波形における直交性は劣化し、誤差レート性能は悪化する。従って、ISUの周波数は、精密な許容誤差に調整されなければならない。再生された信号のタイミングもまた直交性に影響を与える。隣合うシンボルについて時間合わせされていないシンボルは、FFTプロセスの影響を受けるシンボルの一部分内で変化を作り出すことができる。もし全てのシンボルの変化がHDTにおけるガード間隔内に有るならば、非直交チャンネルに対して約 $\pm 16$ トーン( $8DS0+s$ )が再生不可能となるであろう。

上り同期の間、ISUは、振幅及び周波数精度を確立し且つシンボルを合わせるための信号、例えば方形波信号、を送出するよう指令を受ける。パターン信号は、キャリア、振幅及びタイミング再生ブロック222によってパラメータの検出が行える信号であればどのような信号でもよく、このような信号は異なるパラメータを検出するために異なってもよい。例えば、その信号は、振幅及び周波数の検出及び訂正用として連続した正弦波であってもよいし、シンボルタイミング用として方形波であってもよい。キャリア、振幅及びタイミング再生ブロック222は、3つの分配されたループパラメータを評価する。3つのループの全てにおいて、結果として生じる誤差信号はCXC80によってコマンドに変換され、MCC

モデム82を介してI O Cチャンネル上に送出される。そして、C X S Uは、そのコマンドを受信し、I S Uによって行われる調整を制御する。

図22Bに示されるように、I S Uからの上同期は、サンプルホールド(434)され、電圧制御型オシレータ440の制御の下にアナログ-デジタル変換される(432)。この電圧制御型オシレータは局部基準オシレータであり、レシーバアーキテクチャにおけるFFTのポイントであるMで分周を行い、サンプルホールド434及びアナログ-デジタルコンバータ432を制御するためにkで分周を行って、8kHz信号を位相検出器438に印加する。

周波数誤差は、C o s t a sループ430を用いて評価してもよい。C o s t a sループ430は、局部的に生成された基準周波数との位相ロックを確立するよう機能する。時間が経過すると、ループ適応性がディセーブルとされ、時間に関する位相差が周波数誤差を評価するのに用いられる。周波数誤差はフィルタ関数 $H(s)$ 444によって発生され、C X M C 82に供給されて、周波数調整コマンドをI O C制御チャンネルを介してI S Uに送るための処理が行われる。また、周波数誤差は数値制御型オシレータ(N C O)に供給されて、周波数誤差を訂正するための周波数ループが完成する。

振幅誤差は、上り同期の期間中、電力検出器436によってC o s t a sループ430の同相側のキャリアの振幅を検出することにより、キャリアの大きさに基づいて計算される。振幅は、基準コンパレータ443において所望の基準値と比較され、その誤差はC X M C 82に供給されて、振幅調整コマンドをI O C制御チャンネルを介してI S Uに送るための処理が行われる。

H D Tにおいて局部基準周波数が位相ロックを達成すると、I S

Uから到来する同期チャンネル上のB P S K信号が処理のために得られる。方形波は、C o s t a sループ430の同相側で得られ、早-遅ゲート形位相検出器438に供給されて、ティバイダ435から局部的に発生された8kHz信号との比較が行われる。位相検出器435は、ループフィルタ441に印加され且つライン439を介して出力された位相又はシンボルのタイミング誤差を生成する。次いで、位相又はシンボルのタイミング誤差はC X M C 82に供給されて、シン

ボルタイミング調整コマンドをI O C制御チャネルを介してI S Uに送るための処理が行われる。

上り同期のためのパラメータを調整するI S Uのメカニズムは、時間領域での波形のスカラ積でもって振幅を変化させる手段を有しており、このスカラ積は、デジタル-アナログコンバータ194(図13)によってデジタル処理アルゴリズム、例えば逆FFT190、から集められるものである。同様に、複素ミキシング信号を作り出し、デジタル-アナログコンバータ194の入力端に印加される複素倍数として与えることができるであろう。

I S Uにおける下りのサンプルクロック及び上りのサンプルクロックの周波数の精度は、オシレータを下り同期及びI O C情報に位相ロックすることにより確立される。上り伝送周波数は、例えば、H D T 1 2によって指令を受けるシンセサイザブロック195において調整される。

シンボルタイミングの訂正は遅延関数として与えられる。従って、I S Uの上り方向におけるシンボルタイミングの時間合わせは、サンプル間隔(同時に出ていくべき同じ2つのサンプル)をブランクとすることにより、或いはクロックデレイ196(図13)を介して余分のクロックエッジ(1つのサンプルはクロックが出てしまっていて失われている状態)を差し挟むことにより達成される

サンプルタイミングの遅延として確立される。このようにして、既に必要とされている以上のデータ記憶オーバーヘッド無しで、遅延関数を制御することができる。

I S Uがシステムにおいて初期化され活性化されると、伝送の準備のために、I S Uは、必要とされる上りの同期システムパラメータをキャリア、振幅及びタイミング再生ブロック222を用いて維持する。使用されないが初期化され且つ活性化されたI S Uは、I O C上に伝送を行うよう指令を受け、そして、ブロック222はそこからのパラメータを上述したように評価する。

M I S U 6 6 (図13)及びH I S U 6 8 (図14)用の上りトランスミッタアーキテクチャにおいて、H D T 1 2におけるキャリアの直交性を達成するための周波数オフセット又は訂正は、I S U上で決定することができる。これに対し

周波数オフセットは、キャリア、振幅及びタイミング再生ブロック222（図15）によって同期期間中HDTにおいて決定され、次いで、周波数オフセット調整コマンドが、それぞれHISU68及びMISU66のシンセサイザブロック195及び199を介してキャリア周波数の調整のためにISUに送出される。このようにして、もはや周波数誤差は上述したようにキャリア、振幅及びタイミング再生ブロック222によって検出されなくなるであろう。むしろ、そのようなダイレクトISU実施形態において、HISU68又はMISU66が下り信号からデジタル的に周波数誤差を評価し、その訂正信号が、伝送されようとしている上りデータに印加される。

HDT12は、同じ基本オシレータから全ての送信周波数及び受信周波数を抽出する。従って、ミキシング信号は全て、HDTにおいて周波数ロックされている。同様に、HISU68又はMISU66は同じ基本オシレータから全ての送信周波数及び受信周波数を

抽出する。従って、ISU上のミキシング信号もまた全て周波数ロックされている。しかしながら、HDTオシレータに対してISUオシレータには周波数オフセットが存在する。周波数誤差の量は（ISUから見て）ミキシング周波数の固定された割合となるであろう。例えば、ISUオシレータがHDTオシレータに対して周波数で10PPMオフし、下りISUレシーバにおける混合周波数が100MHzで、且つ、上りISUトランスミッタにおける混合周波数が10MHzであったとしたならば、ISUは、下りレシーバ上で1kHzの訂正を行わねばならないであろうし、上りトランスミッタ上で100Hzのオフセットを持つ信号を生成しなければならないであろう。このようにダイレクトISU実施形態においては、周波数オフセットは下り信号から評価される。

評価は、数値計算を行うデジタル回路、すなわちプロセッサを用いて実行される。同期チャンネル又はIOCチャンネルのサンプルは、システムの作動中にハードウェアで集められる。追跡用ループは、受信信号に対してデジタル的に混合されるデジタル数値オシレータを駆動する。このプロセスは、本質的にはHDTにロックされる信号を内部で抽出する。内部での数値ミキシングは周波数オフ

セットの要因となる。ISUにおいて下り信号へのロック処理が行われている間、周波数誤差の評価がひき出され、下り周波数を既知として分数周波数誤差が計算され得る。上りの受信信号をダウン変換するのに用いられるであろうHDTにおいてミキシング周波数が知られているものとして、ISU送信周波数に対するオフセットが計算される。この周波数オフセットは、例えば図13のコンバータ194によって信号をアナログ領域に変換する前にデジタル的にISU送信信号に印加される。従って、周波数の訂正はISU上で直接実行され得る。

図20及び図21を参照しながら、多相フィルタ構造を含むMCC上りレシーバアーキテクチャの狭帯域イングレスフィルタ及びFFT112について更に詳細に説明する。一般に、多相フィルタ構造は、多相フィルタ122及び124を含み、イングレスに対する保護を提供する。ISU100からの上りOFDMキャリアの6MHz帯域は、小グループのキャリア又はトーンに対してフィルタリングを提供する多相フィルタを通してサブバンドに分割される。もしイングレスが1グループのキャリア内のキャリアに影響を与えたならば、当該グループのキャリアのみが影響を受けることになり、他のグループのキャリアはそのフィルタリング特性によって保護されることになる。

イングレスフィルタ構造は、2つの並列的な多相フィルタのバンク122, 124を有している。第1のバンクは、互いに重なり合わない17の異なる帯域を有し、帯域間にはチャンネル間隔が設けられている。図18には単一の多相フィルタバンクの振幅応答が示される。第2のバンクは、第1のバンクによって汜波されないチャンネルが第2のバンクによって汜波されるような量だけ第1のバンクからオフセットしている。従って、図19において単一の多相フィルタバンクの拡大された振幅応答に示されるように、汜波されたチャンネルの1つの帯域は、フィルタを通過しようとしている周波数ビン45-61に対応する中心キャリアを持つ周波数ビン38-68におけるチャンネルを含む。例えば、重なり合っているフィルタは周波数ビン28-44を通過させる。2つのチャンネルバンクは、2つのフィルタバンクの組み合わせによって544個のチャンネルの各々が受信されるように16個の周波数ビンだけ互いにオフセットしている。

図20を参照すると、イングレスフィルタ構造は、アナログーデ

ィジタルコンバータ212からサンプルされた波形 $x(k)$ を受信し、次いで、複素ミキサ118及び120は、多相フィルタ122, 124に交互に信号を印加する。ミキサ118は一定の値を使用し、ミキサ120はオフセットを達成するような値を使用する。各ミキサの出力はそれぞれ対応する多相フィルタ122, 124に入力される。各々の多相フィルタバンクの出力は18個の帯域を有しており、各帯域は、16個の使用可能なFFTビンを含むか、又は、8kHzレートで16のキャリアをサポートする。帯域の1つは使用されない。

多相フィルタ122, 124の各帯域出力は、4つのガードサンプルを含む8kHzフレーム毎に36のサンプルを含み、高速フーリエ変換(FFT)ブロック126, 128に入力される。FFTブロック126, 128によって実行される第1の動作は、4つのガードサンプルを除去し、時間領域での32個のポイントを残すことである。ブロックにおける各FFTの出力は32個の周波数ビンであり、このうち16個はフィルタリングを提供する他のビンと共に用いられる。FFTの各出力は互いに重なり合うように形成される。図20に示されるように、キャリア0-15は上のバンクのFFT#1によって出力され、キャリア16-31は下のバンクのFFT#1によって出力され、キャリア32-48は上のバンクのFFT#2によって出力され、以下、同様にして出力される。

多相フィルタ122, 124はそれぞれ、当業者には知られているような標準の多相フィルタ構造であり、図21の構造によって示される。入力信号は、1秒当たり5.184メガサンプル、すなわち1フレーム当たり648サンプル、でサンプルされる。次いで、その入力18のファクタによって(18サンプルのうち1つが保持される)処理が施され、288kHzの有効なサンプル率が得ら

れる。この信号は、 $H_{0,0}(Z) \sim H_{0,15}(Z)$ とラベル付けされた有限インパルス応答(FIR)フィルタに供給される。各フィルタは幾つかのタップ、それぞれ好適には5つのタップを有している。当業者には認識されるように、タップの数は変えることが可能であり、本発明の範囲を制限するものではない。フィルタから

の出力は18ポイント逆FFT130に入力される。変換後の出力は、4つのガードサンプルを含む8KHzフレームに対して36サンプルであり、上述したようにFFTブロック126及び128に供給される。FFTのトーンは好適には9KHzの間隔で設定されており、情報レートは、1シンボル当たり4つのガードサンプルが割り当てられている場合に1秒当たり8キロシンボルである。各多相フィルタからの17の帯域はFFTブロック126、128に印加され、上述したように544個のキャリアの処理及び出力が行われる。上述したように、1つの帯域、すなわち18番目の帯域は使用されない。

上り及び下りのレシーバアーキテクチャにおけるイコライザ214(図15)及び172(図11)は、ケーブルプラントにかかるグループ遅延の変化を相殺するために設けられている。イコライザは、環境の変化に起因する位相及びゲイン又は振幅の変動を追跡し、それによって、十分に正確な追跡を維持しながら緩慢に適應することができる。内部イコライザ動作が図23に一般的に示されているところの各イコライザ172、214の係数360は、FFT112、170の解像度に対するチャンネル周波数応答の逆数を表している。下りの係数は、各チャンネルが同じ信号パスを通して進行しているが故に高度に相関がとられており、これに対し上りの係数は、個々のDSO+sが多点对点トポロジーにおいて遭遇する変わりやすいチャンネルに起因して相関がとられていない。チャンネル特性は多様であるが、イコライザは、上りレシーバ又は下りレシーバに対し

て同じ動作を行う。

下りのイコライザは、IOCチャンネルのみに対して追跡を行い、それによってISUにおける計算の必要性を少なくすると共に、パイロードチャンネルにおける前処理の必要性を無くしている。なぜなら、IOCチャンネルは常に伝送されているからであり、これについては以下に記述される。但し、上りのイコライザについては、DSO+及びIOCチャンネルベースでイコライズ処理が必要とされる。

イコライザの係数を更新するのに用いられるアルゴリズムは、32QAM群上で動作する時に幾つかの局所的な最小値を含み、4重の位相的にあいまいな状態



を受ける。更に、上りにおける各DSO+は、別々のISUから発することができ、それによって独立した位相シフトを持つことができる。この問題を軽減するために、データ伝送に先立って各通信の開始が固定のシンボルプリアンブルを知らせるのに必要とされるであろう。但し、IOCチャンネルはこの必要性から除外される。なぜなら、IOCチャンネルはイコライズされないし、またそのプリアンブルはスクランブルされ得ないからである。伝送の時点で、HDT12が、ISUの初期化及び活性化の間確立されている正確な周波数ロック及びシンボルタイミングをまだ有しており、且つ、連続して利用し得る下りのIOCチャンネル上で同期を維持するであろうことは知られている。

プリアンブルの最初の部分は、イコライザがそのプロセス状態を認識することを必要としている。3つの状態があり、サーチ、獲得及びトラッキングのモードが含まれている。サーチモードは、チャンネル上の電力の量に基づいている。トランスミッタアルゴリズムは、使用されていないFFTビンにゼロ値を設定し、その結果として、その特定の周波数で電力は伝送されなくなる。レシーバでは、イ

コライザは、それはFFTビンに電力が無いことに基づくサーチモードであると決定する。

初期化され活性化されたISUに対して伝送が始まると、イコライザは、信号の存在を検出し、獲得モードに入る。プリアンブルの長さはおよそ15シンボルである。イコライザは、そのプリアンブルに基づいてイコライズ処理を変える。初期の位相及び振幅の訂正は大きいであろうが、その後の係数の更新によってそれほど意味はなくなるであろう。

獲得が終わると、イコライザは、更新レートを最小レベルに低減したままでトラッキングモードに入る。トラッキングモードは、電力の損失が一定期間中チャンネル上で検出されるまで続く。次いで、そのチャンネルは、使用されないが初期化され且つ活性化された状態となる。イコライザはもはや追跡を行わず、この時、レシーバは調整されつつあり、また係数は更新されない。係数は、以下に記述するように、チャンネルをモニタするための信号対ノイズ検出器305(図15)によってアクセスされ使用されてもよい。

イコライズ処理のために、I/Q成分が、FFT、例えばFFT112, 180の出力端でバッファ内にロードされる。当業者には明らかなように、イコライザの構造についての以下の記載は、上りレシーバのイコライザ214に関するものであるが、下りレシーバのイコライザ172にも同様に適用され得る。イコライザ214は、バッファから時間領域でのサンプルを抽出し、一度に1つの複素サンプルを処理する。次いで、処理された情報はそこから出力される。図23は当業者には明らかであるべきスタティック制御アルゴリズムよりも小さいイコライザアルゴリズムの基本構造を示す。主な同期パスは、乗算器370での複素数と選択されたFFTピンからの値との乗算を行うことである。次いで、その出力はシンボル量

量子化ブロック366において量子化され、格納テーブルから最も近いシンボル値とされる。量子化された値(ハード決定)は、シンボル対ビットコンバータ216によってデコードされビットに変換される。回路の残りの部分は、イコライザの係数を更新するのに用いられる。量子化されたシンボル値とイコライズ処理されたサンプルとの間の誤差が加算器364で計算される。この複素誤差は乗算器363によって受信サンプルに乘じられ、その結果は乗算器362によって適応係数分スケール処理されて、更新値を形成する。更新値は加算器368で元の係数と加算され、新たな係数値となる。

#### 第1実施例の動作

好適な実施例において、HDT12の各MCCモデム82のための6MHz周波数帯域は図9Aに示すように割り当てられる。MCCモデム82は6MHz帯域全体について送受信を行なうが、ISUモデム100(図6)はそれらの特定の用途に対して最適化され6MHz帯域に割り当てられたキャリア又はトーンの総数よりも少ない数のものを終端し発生する。上り及び下り帯域の割り当ては好適には対称である。MCCモデム82からの上り6MHz帯域は5~40MHzスペクトル内にあり、下り6MHz帯域は725~760MHzスペクトル内にある。各6MHz帯域には、電話ペイロードデータの転送、ISUシステムの運用及び制御データ(10C制御データ)の転送、及び上りと下りの同期化のような特定の動作をサポートするために3つの領域がある。OFDM

周波数帯域における各キャリア又はトーンは振幅及び位相変調されて以前に記述した複雑な信号点配置を形成する正弦波からなる。OFDM波形の基本シンボル速度は8kHzであり、6MHz帯域内に全部で552のトーンがある。次の表1は各種のトーンに対する好適な変調形式及び帯域幅割り当ての要約である。

表 1

帯域割当	トーン又はキャリアの数	変調	容量	帯域幅
同期帯域	24トーン（各終縁部の2周期トーンと各終縁部の10ガードトーン）	BPSK	n/a	216kHz
ペイロードデータ	480（240DSO+チャンネル）	32QAM	19.2Mbps	4.32MHz
IOC	48（20データチャンネルまたは24IOCチャンネルのそれぞれに2）	BPSK	384Kbps	432kHz
帯域間ガード	各終縁部の残り	n/a	n/a	1,032MHz （各終縁部において518kHz）
複合信号	552	n/a	n/a	6.0MHz

送信後及び受信前の選択的濾波を可能にするためにスペクトルの各終縁部にガードバンドが設けられる。総計で240の電話データチャンネルが帯域内に含まれ、それは19.2Mbpsの正味データ速度を収容する。この容量は将来の加入者増を考慮して設計されたが、それによって中央局へのユーザの集中を達成するために十分なサポートが維持された。冗長性と多数のHISUに配置された狭帯域レシーバに対する通信サポートを提供するために多数のIOCチャンネルが帯域内に散在する。IOCのデータ速度は16Kbps（1秒あたりに8kHzのフレームのシンボル速度のBPSKトーンが2つ）である。實際上、10ペイロードデータチャンネルあたりに1つのIOCが設けられる。単一のIOCチャンネルしか見ることができないHISUのようなISUはそのIOCチャンネルが損なわれたら強制的に再同調される。しかしながら、MISUのように、複数のIOCチャンネルを見ることができるISUは最初に選んだものが損なわれても別のIOCチャンネルを選択することができる。

同期チャンネルは冗長化のために帯域の終縁部において二重化され

、同期チャネルが他の使用チャネルと干渉しないことを確保するために使用可能なキャリアの本体部から離れている。同期チャネルについては以前に説明したが以下にさらに説明する。同期チャネルは電話ペイロードチャネルへの干渉の影響を減らすためにもその様なチャネルよりも低いパワーレベルで運用される。このようにパワーを低くすれば、同期チャネルとペイロード電話チャネルの間に用いられるべきガードバンドを小さくできる効果も得られる。

1つの同期チャネル又は冗長化した複数の同期チャネルは電話チャネルから離すのではなくその内部に設けることも可能である。それらが電話チャネルと干渉しないようにするため、同期チャネルを低シンボル速度を使って設けることも可能である。例えば、電話チャネルが8 KHzのシンボル速度であれば、同期チャネルを2 KHzのシンボル速度にすれば良く、それに加えてパワーレベルを低くしても良い。

ISU100は図9Dに示すように全体の6 MHz スペクトルの集まりのうちサブバンドを受信するように設計される。例として、HISU68は好適には利用可能な522チャネルのうち22チャネルのみを検出する。このような実現方法は主として電力あたりのコストを削減する技術である。受信されるチャネルの数を削減することにより、サンプル速度及び関連の処理要件は劇的に減少し今日の市場にある普通の交換部品で達成することができる。

与えられたHISU68はHISU受信周波数の点でペイロードデータチャネルのうち最大10個のDSOの受信に制限されている。残りのチャネルはガード区間として使用される。さらに、コストあたりの電力の要件を減らすため、周波数合成の刻みは198KHzに制限され、それによってHISUの同調範囲は8チャネルセグメントに制限される。図9Dに示すようにHDT12によるHISU68の制御のために各HISU68が常に

1つの10Cチャネルを見るように10Cチャネルが設けられる。

MISU66は図9Dに示すように13のサブバンド又は利用可能な240のDSOのうち130のDSOを受信すべく設計される。同様に、効率的な周波数合成の実現のために同調の刻みは128KHzに制限される。これらはHISU68及びMISU66に対して好適な値であり、ここに特定された値の多くは添付の請求項に定義される発明の範囲

又は精神を変更することなく変更可能であることは当業者にとって明らかなことである。

当業者に公知の如く、6 MHz 以下の帯域幅におけるチャンネル間の動作をサポートする必要がある。当業者に明らかなようにシステムのソフトウェア及びハードウェアの適切な変更により、この様な再構成は可能である。例えば、2 MHz システムについては、下りにおいて、HDT12は帯域全体の部分集合の範囲のチャンネルを生成する。HISUは本来狭帯域であり2 MHz 帯域内に同調することができる。130チャンネルをサポートするMISUは2 MHz 帯域よりも広い範囲の信号を受信する。それらはハードウェアの変更によりフィルタの選択性を低下させる必要がある。80チャンネルのMISUは2 MHz システムの制約の中で動作することができる。上りにおいては、HISUは2 MHz 帯域内の信号を生成し、MISUの送信部は生成される情報を狭帯域に制限する。HDT12においては、入り口における入波によって帯域信号エネルギーに対して十分な選択性が得られる。狭帯域システムは2 MHz 帯域の端部に同期帯域を必要とする。

以前に記述したように、下り情報の検出のためのシステムの初期化のための信号パラメータの収集は下り同期チャンネルを使って達成される。ISUはそのような下り情報の検出のための周波数、振幅及びタイミングの下り同期を確立するためにキャリア／振幅／タイミング再生ブロック 166を使用する。下り信号は1対多接続を構成し

OFDM波形は固有の同期的態様で単一の経路で ISUに到達する。

上り方向においては各ISU100は HDT12がISU100に送信を許可する前に上り同期化の過程を通して初期化され活性化される必要がある。ISUに対する上り同期化の過程は異なる ISUからの波形が HDT12において結合されて統合された波形になる役割を果たす。上り同期化の過程は、その一部が以前に説明されたが、種々のステップを含んでいる。それらは、ISU送信レベル調整、上りマルチキャリアシンボルの整列化、キャリア周波数の調整、周回遅延の調整を含んでいる。この様な同期化は6 MHz 帯域動作の獲得の後に行なわれる。

一般に、レベル調整に関して、HDT12はISU100から受信した上り伝送の信号強

度の測定値を校正し、ISU100送信レベルをすべてのISUが容認可能な閾値内にあ  
るよう調整する。レベル調整はシンボルの整列化及び経路遅延の調整の精度を  
最大にするためそれらに先行して行なわれる。

一般に、シンボルの整列化はMCCモデム82及びISUモデム101によって実現さ  
れるマルチキャリア変調の手法にとって必須の要件である。伝送の下り方向にお  
いては、ISU100において受信されるすべての情報は単一のCXMU56によって生成さ  
れるので、各マルチキャリア上で変調されたシンボルは自動的に位相が揃ってい  
る。しかしながら、MCCモデム82受信機レシーバアーキテクチャにおけるシンボ  
ルの整列化はHFC分散ネットワーク11の多対1性及びISU100の経路の不均一な遅  
延のために変化する。受信の効率を最大にするため、すべての上りシンボルは狭  
い位相マージン内で整列化されなければならない。このことは、異なるISUから  
上りで受信されるすべてのチャンネルのシンボル周期がそれらがHDT12に到達す  
る時点で揃うように調節可能遅延パスを各ISU100に設けることにより達成される。

一般に、周回遅延の調整はシステムにおいてHDTネットワークイ

ンターフェース62からすべてのISU100まで及びすべてのISU100からネットワーク  
インターフェース62へ戻るまでが等しくなるように行なわれる。このことはシグ  
ナリングマルチフレームの完全さがシステム全体で確保されるために必要である  
。電話伝送部に対するすべての周回処理はHFC分散ネットワーク11自身における  
信号伝播に関連する物理的遅延を除いて予測可能な遅延を有している。HDT12か  
ら近い物理的距離にあるISU100はHDT12から最大の距離にあるISUよりも短い  
周回遅延を持つであろう。経路遅延の調整はすべてのISUの転送システムに等し  
い周回伝播遅延を持たせるべく実現される。これによりシステム内で転送される  
DSIチャンネルについてのDSIマルチフレームの整列化もまた維持され、そのDSI  
に関連する音声サービスについての整列化に関する帯域内チャンネルシグナリング  
またはロブドビット(robbed-bit)シグナリングを維持する。

一般に、キャリア周波数調整はキャリア周波数の間隔がキャリアの直交性を維  
持するように達成されなければならない。直交整列化においてマルチキャリアが  
MCCモデム82で受信されないならば、マルチキャリア間の干渉が起きている可能

性がある。このようなキャリア周波数調整はシンボルタイミング又は振幅の調整の場合と同様な形で達成することができるかまたは以前に説明したように ISU上で実現することができる。

初期化の過程において、ISUに電源が投入されたとき、ISU100ほどの下り6 MHz 周波数帯域を受信すべきかに関する知識を持っておらず初期化の動作ステップのために6 MHz 帯域を獲得する必要がある。ISU100が動作のための6 MHz 帯域の獲得に成功するまで、それはその下り周波数帯域の位置を決めるために“走査”の手法を実施する。ISU100 のCXSUコントローラ 102のローカルプロセッサは 62.5乃至850MHzの範囲内どこかのデフォルトの6 MHz 受信周波数帯域

から開始する。ISU100は各6 MHz 帯域において一定期間、例えば 100ミリ秒間待ってそのISU100に対するユニークな識別番号と一致する有効な6 MHz 獲得コマンドを探す。その様なユニークな識別子は ISU機器のシリアル番号の形式またはそれに基づく形式をとることができる。その6 MHz 帯域に有効な6 MHz 獲得コマンドがなければ、CXSUコントローラ 102は次の6 MHz 帯域を探し、その様な過程が繰り返される。この様にして、さらに以下に説明するように、HDT12はISU100に対して周波数受信のためにどの6 MHz 帯域を使用すべきか及び上りの周波数送信のためにどの帯域を使用すべきかを告げることができる。

上記に説明したような ISUの初期化及び活性化の過程、及びトラッキングまたは追跡同期化について以下にさらに説明する。この説明はCXSUコントローラ 103と共にMISU66を使用して書かれているが、等価な制御ロジックで実現された任意のISU100に等しく適用することができる。コアックスマスタカードロジック (CXMC) 80はそのシェルフコントローラユニット (SCNU) 58に指示されて特定のISU100を初期化し活性化する。CXMC80は ISU指定番号をその機器に対する機器シリアル番号またはユニークな識別番号に関連付ける。製造過程から出荷された ISU機器で同一のユニーク識別子を持つものは2つとない。そのときのシステムデータベースにおいてそのISU100が一度も初期化され活性化されたことがなければ、CXMC80は初期化され活性化されるISU100のために或る個人識別番号(PIN)コードを選択する。このPINコードはCXMC80内に格納され、そのISU100とのすべての通信

のたの“アドレス”となる。CXMC80は各 ISU識別番号と、ISU機器に対するユニークな識別子と、PINコードとの間の参照テーブルを維持管理する。CXMU56に関連する各ISU100はユニークな PINアドレスコードの割り当てを有する。1つの PINアドレスコ

ードは、HDTがすべての初期化され活性化されたISU100へメッセージを送ることを許す、すべての ISUに対する同報的な性格のために保持される。

CXMC80は MCCモデム82による認識メッセージをそれが送信する6 MHz 帯域のすべての IOCチャンネルを介して送信する。そのメッセージは、初期化され活性化されるべき ISUに割り当てられた PINアドレスコード、ISU100において ISUの初期化及び活性化が行なわれるべきであることを示すコマンド、機器シリアル番号の様な ISU機器に対するユニークな識別子、及びCRC(Cyclical redundancy checksum)を含んでいる。そのメッセージは或る周期で周期的に送られる。この周期は有効な識別メッセージを監視している ISUがすべての下り6 MHz 帯域を走査できる最大の時間である。その周期は例えば50ミリ秒であり、ISUがいかに早く自己を認識し得るかに影響する。CXMCは1度に1つ以上の ISUについて同期させようとはしない。或る最大制限時間を越えた後にも ISUが応答しないならば、ソフトウェアタイムアウトが働く。このタイムアウトは ISUが同期機能を達成するために必要な最大制限時間以上でなければならない。

CXMC80による周期的な伝送の間、ISUはその下り周波数の位置を決定するために走査の手法を実施する。CXSUのローカルプロセッサは 625乃至850MHzの範囲内のどこかのデフォルトの6 MHz 受信周波数帯域から始める。ISU100は最初の6 MHz の同期チャンネルを選択し一定時間後に同期にずれがあるかを試す。同期はずれが依然としてあれば2番目の同期チャンネルを選択し一定時間後に同期はずれがあるかを試す。同期はずれが依然としてあれば ISUは次の6 MHz 帯域上の同期チャンネルの選択を再開する。或る周期チャンネルにおいて同期はずれがないとき、ISUは IOCを含む最初のサブバンドを選択して正しい識別メッセージを探す。そのユニークな識別子と一致す



る正しい識別メッセージが見つかったら、PINアドレスコードが適切なレジスタにラッチされる。第1のサブバンドに正しい識別メッセージがなければ11番目のサブバンドのような中間のサブバンドが選択され、ISUは再び正しい識別メッセージを探す。再びメッセージが正しくなければ ISUは他の6 MHz 帯域上で再開する。ISUは1つのサブバンドにおいてCXMUの伝送時間の少なくとも2倍に等しい期間、例えば前述したように伝送時間が50ミリ秒であるとき 100ミリ秒間、正しい識別メッセージを探す。初期化及び活性化コマンドはISU100においてユニークなコマンドである。その理由はISU100はそのコマンドに応答するために PINアドレスコードの一致は必要とせず、有効なユニークな識別子と CRCの一致があれば良いからである。しかしながら、MCCモデム82によりCXMC80から送られる初期化及び活性化コマンドは有効な PINアドレスコードの一致がないときにISU100が受信することを許された唯一のコマンドである。初期化されず活性化されていないISU100が或る 10Cチャンネル上で MCCモデム82によるCXMC80からの初期化及び活性化コマンドと、ユニークな識別子に一致するデータと、正しい CRCとを受信すると、ISU100の CXSU102はそのコマンドとユニークな識別子とともに送られてきた PINアドレスコードを格納する。このときから、ISU100は、再び活性化されて新しい PINアドレスコードを与えられる場合を除くことは勿論であるが、その正しい PINアドレスコードまたは同報アドレスコードによってそれをアドレス指定するコマンドに対してのみ応答する。

ISU100がそのユニークな識別子に一致するものを受け取った後、ISU100は、上り送信のためにどの6 MHz 帯域を使うべきか及びISU100が使用すべき上りの 10Cチャンネルのためのキャリア又はトーンの指定をISU100に告げる PINアドレスコードを伴った上り周波数帯域

コマンドを受け取る。CXSUコントローラ 102はそのコマンドを解釈して応答するための正しい上り周波数帯域のためのISU100の ISUモデム 101を正しく活性化する。一旦 ISUモデム 101正しい6 MHz 帯域を獲得すると、CXSUコントローラ 103は ISUモデム 101へ或るメッセージコマンドを送って上りの同期を可能にする。HDT12の MCCモデム上りレシーバアーキテクチャのキャリア、振幅、及びタイム

ング再生ブロック 222を使用する分散化ループは、振幅、キャリア周波数、シンボル整列化、及び経路遅延を含む上り伝送の様々な ISUパラメータをロックするために使用される。

図16はこの分散化ループを包括的に記述している。新しいユニットがケーブルに掛けられると、HDT12はケーブルに掛けられた ISUに対して、他のISU100に対して排他的な上り同期モードに入るように指示する。HDTは新しい ISUに関する情報を受け取り、加入者 ISUユニットに対して種々のパラメータについての下りコマンドを与える。ISUは上りの送信を開始し HDT12は上り信号にロックする。HDT12は調節されるべきパラメータに関するエラーインジケータを引き出し、加入者 ISUに対してそのパラメータの調整を命令する。エラーの調整はISUの送信のためのパラメータが HDT12にロックされるまで処理が繰り返される。

より特定すれば、ISU100が動作のための6 MHz 帯域を獲得した後、CXSU102はISUモデム 101へ或るメッセージコマンドを送り、ISUモデム 101は図9に示すようなスペクトル割り当ての最初の同期帯域における同期チャンネル上に同期パターンを送る。図9に割り当てられたようにペイロードデータチャンネルから離れている上り同期チャンネルは、同期チャンネルの1つが損なわれても上り同期化が達成できるように、初期及び冗長化同期チャンネルの双方を含んでいる。

MCCモデム82は有効な信号を検出し ISUからの受信信号に対して

振幅レベルの測定を行なう。同期パターンはCXMC80に対してISU100が活性化及び初期化及び周波数帯域コマンドを受け取り上り同期化を行なう準備ができていることを示す。振幅レベルは所望の基準レベルと比較される。CXMC80はISU100の送信レベルを調整すべきか否か及びその調節量を決定する。レベル調整が必要であれば、CXMC80は下り IOCチャンネル上にメッセージを送信してISU100の CXSU102に ISUモデム 101の送信のパワーレベルを調整するように指令する。CXMC80はISU100からの受信パワーレベルのチェックをし続け、ISU100によって送信されるレベルが容認できるものになるまでISU100へ調整コマンドを出す。振幅は ISUにおいて以前に議論したように調整される。初期の同期チャンネルを使って或る回数だけ振幅調整を繰り返しても振幅が平衡に達しないならば、または信号の存在が検出

されないならば、同じ処理が冗長化同期チャンネル上で行なわれる。初期及び冗長化同期チャンネルを使って或る回数だけ振幅調整を繰り返しても振幅が平衡に達しないならば、または信号の存在が検出されないならば、ISUはリセットされる。

ISU100の送信レベルに調整が完了し安定化したら、CXMC80と MCCモデム82はキャリア周波数ロックを行なう。MCCモデム82はISU100によって送信されたキャリア周波数を検出しISU100からの受信信号に対して相関処理を行なって ISUからのすべての上り送信のマルチキャリアの直交整列化を行なうために必要なキャリア周波数の誤差量を計算する。MCCモデム82は ISUについて周波数の整列化を達成するために必要なキャリア周波数のエラー調整の量を示すメッセージをCXMC80へ戻す。CXMC80は MCCモデム82により下り 10Cチャンネル上にメッセージを送って CXSU102へ ISUモデム 101の送信周波数を調節するように指令し周波数がOFDMチャンネル間隔に対する或る許容範囲内になるまでその処理が繰り返される。このような調整は少なくとも

シンセサイザブロック195(図13及び図14)によりなされる。周波数ロック及び調整が前述のように ISUについて達成されたら、この周波数調整方法は使われない。

直交性を達成するため、CXMC80と MCC82はシンボル整列化を行なう。MCCモデム82は ISUモデム 101によって送信される8 KHz フレームレートで変調された同期チャンネルを検出しすべての異なるISU100からの上り ISU送信に対してシンボル整列化を行なうに必要な遅延相関を計算するために受信信号に対してハードウェア相関処理を行なう。MCCモデム82は、すべてのシンボルが HDT12において同時に受信されるようにISU100をシンボル整列化するために必要な遅延調節量を示すメッセージをCXMC80へ戻す。CXMC80は MCCモデム82によって下り 10Cチャンネルにメッセージを送って CXMU103に ISUモデム 101の送信の遅延を調節するように指令し、この処理は ISUのシンボル整列化が達成されるまで繰り返される。このようなシンボル整列化は少なくともクロックディレイ196(図13及び図14)によって調節される。シンボル整列化が平衡に達するまでに多数の繰り返しが必要であり、所定の繰り返し数内で平衡に達しなければ ISUは再びリセットされる。

シンボル整列化と同時に、CXMC80は経路遅延の調整を行なうために MCCモデム 82へメッセージを送る。CXMC80は MCCモデム 82により下り 10Cチャンネル上にメッセージを送って、ISUモデム 101がISU100のマルチフレーム(2 KHz)の整列化を示す同期チャンネル上に他の信号を送ることを可能にするようにCXSUコントローラへ指令する。MCCモデム 82はこのマルチフレーム整列化パターンを検出しパターンに対してハードウェア相関処理を行なう。この相関から、モデム 82は通信システムの周回経路遅延に合わせるために必要な付加的なシンボル周期を計算する。次に、MCCモデム 82は全体の経路遅延の

要求に見合うように付加しなければならない遅延量を示すメッセージをCXMC80へ戻し、CXMCは MCCモデム 82により下り 10Cチャンネル上にメッセージを送ってCXSUコントローラ 102に対して経路遅延調整値を含むメッセージを ISUモデム 101へ中継するように指令する。経路遅延が平衡に達するまでに多数の繰り返しが必要であり、所定数の繰り返し内で平衡に達しなければ、ISUは再びリセットされる。このような調整は図13及び図14の上り送信機アーキテクチャの表示ディスプレイバッファ“n”サンプル 192に見られるような ISUトランスミッタにおいてなされる。経路遅延及びシンボル整列化は同期化チャンネル上に送られる同一または異なる信号を使って同時に別々または一緒に行なわれる。

ISUが初期化され活性化されるまでは、ISU100は 480トーン又はキャリアのいずれにおいても電話データ情報の送信能力を持たない。初期化及び活性化が完了した後は、ISU100はOFDM波形内の送信に必要な範囲内にあることになり、ISUは送信が可能であることを通知され上り同期化が完了する。

ISU100がシステムに対して初期化され活性化された後、OFDM転送の要件が要求する範囲内に ISUが校正された状態を保つために追跡及び同期化またはトラッキングが周期的に行なわれる。追跡処理は要素の値の温度ドリフトを考慮して実現される。ISU100が長い期間使われていなかったものであれば、ISUは同期チャンネルに同調され前述の上り同期化処理に従って上り同期パラメータを更新することが要求される。そうではなくて ISU最近使われたものであれば追跡同期化またはトラッキングは 10Cチャンネル上で行なうことができる。このシナリオのもとでは

、図17に一般的に示されるように、ISU100は IO Cチャンネルを通して信号を出すことが HDT12から要求される。HDT12はその信号がOFDM波形内のチャンネルに要求される範囲内に

あることを検証する。そうでなければ ISUはその様な誤ったパラメータを調整することが要求される。さらに、長い使用期間中に ISUは上り同期化パラメータの更新を目的として IO Cチャンネルまたは同期化チャンネル上に信号を送ることを HDT12から要求される。

下り方向においては、IO CチャンネルはISU100への制御情報を転送する。変調形式は好適には差分符号化BPSKであるが、下り変調の差分特性は必須ではない。上り方向においては、IO Cチャンネルは HDT12への制御情報を転送する。IO Cチャンネルは上り方向ヘデータを送る際の等化器に関連した遷移時間を軽減するために差分BPSK変調される。制御データはバイトバウンダリ(500 $\mu$ sフレーム)で挿入される。任意の ISUからのデータは IO Cチャンネル上で非同期で転送することができ、従って衝突が起こる可能性がある。

衝突の可能性があるため、上り IO Cチャンネル上の衝突の検出がデータプロトコルのレベルで行なわれる。そのような衝突を取り扱うプロトコルは例えば ISUによる指数関数的なバックオフを含んでいる。HDT12が送信エラーを検出するとき、特定の時間だけ待った後 ISUが IO Cチャンネル上に上り信号を再送するように再送コマンドがすべての ISUへ同報通信される。待ち時間は指数関数に基づく。

当業者は HDTから指令されたように ISUがシンボルタイミングを調節するためのシンボルタイミンググループのみを使って多対1伝送を許しつつ上り同期化を実現しうることを認識している。上り同期化のための周波数ループについては、ISUにおいて IDTにロックしていない高品質の局部自走発振器を使用すれば、省略可能である。さらに、ISUの局部発振器は外部基準にロックさせることもできる。振幅ループは HDTにおけるシンボル整列化を達成する上で本質的ではない。

通信システム10における呼処理は、HDT12からISU100への電話伝

送のためのシステムのチャンネルを加入者に割り当てる過程を伴う。本発明に係る

通信システムは集線処理を含まない呼処理技術例えばTR-8サービスとTR-303サービスのような集線処理を含むものの双方をサポートすることができる。集線処理は ISUにサービスしているチャンネルの数以上のサービスを要求する ISU端末が存在するとき起こる。例えば、システムに対して1000の加入者線端末がある一方でそのような加入者へサービスを提供するために割り当てることができるペイロードチャンネルの数が 240のみであるときである。

TR-8の運用のように集線処理が必要でないとき、6 MHz スペクトル内でチャンネルが静的に割り当てられる。したがって、チャンネルの再割当のみがチャンネルの監視に関して以下にさらに議論される。

一方、TR-303サービスを提供するもののような集線処理を提供するための動的に割り当てられたチャンネルについては、HDT12は HFC分散ネットワーク11上での電話データの転送のためのオンデマンドなチャンネル割当をサポートする。そのような動的なチャンネル割当は HDT12とISU100の間の直信のための IOCチャンネルを利用して達成される。ISU100の加入者への着呼に対してまたはISU100の加入者から発呼に対してチャンネルが動的に割り当てられる。以前に議論したように HDT12のCXMU56は HDT12とISU100の間の呼処理情報を担う IOCチャンネルを実現する。特に、IOCチャンネル上には次の呼処理メッセージが存在する。それらは少なくとも ISUから HDTへの回線捕獲またはオフフックメッセージと、ISUから HDTへの回線開放またはオンフックメッセージと、HDTと ISUの間の使用可能及び使用不能回線アイドル検出メッセージを含んでいる。

HFC分散ネットワーク11上の加入者への呼については、CTSU54はその加入者線端末に関連するCXMU56へメッセージを送り、CXMU56へ HFC分散ネットワーク上で呼の転送のためのチャンネルを割り当て

るように指示する。CXMU56は呼が意図しているISU100によって受信されるべき IOCチャンネル上にコマンドを挿入する。そのコマンドは割り当てられたチャンネルについてISU100へ警告するために CXSU102へ適切な情報を提供する。

ISU側の加入者からの発呼の際には、各 ISUは回線捕獲のためにチャンネルを監視する責任がある。回線捕獲が検出されたとき、回線の使用を開始するためにIS

U100はこの変化を PINアドレスコードとともに上り IOG動作チャンネルを使って HDT12の CXMU56へ伝えなければならない。CXMU56が回線捕獲メッセージを正しく受け取ったら、CXMU56はこの内容をさらに呼を設定するために変換網へ必要な情報を提供する CTSU54へ転送する。CTSU54はチャンネルが利用可能か否かをチェックし、ISU100で発せられた呼にチャンネルを割り当てる。ISUからの呼を完成するためのチャンネルが同定されたら、CXMUは回線捕獲を要求している ISU100へ下り IOGチャンネルを介してチャンネルを割り当てる。加入者がオンフック信号を戻したとき、適切な回線アイドルメッセージが上りで HDT12へ送られ、HDT12はそのチャンネルが再び TR-303サービスをサポートするために割り当てることができるようにその情報を CTSU54へ提供する。

アイドルチャンネル検出はさらに他の技術を利用しているモデムにおいても達成しうる。ISU100の加入者がデータペイロードチャンネルの使用を終了した後、MCCモデム82は以前に割り当てたチャンネルがアイドル状態であることを決定することができる。アイドル検出は複素（I及びQ成分）シンボル値を出力する FFTの結果を調べる等化器214(図15)による等化処理を利用して達成しうる。等化に関して以前に議論したようにエラーが計算され、それは等化器の係数を更新するために使用される。代表的には、等化器が信号を獲得し有効なデータ検出されるとき、誤差信号は小さい。信号が終了すると

誤差信号は増加し、このことは S/N モニタ 305で監視することができ、それによって使用されているペイロードデータチャンネルの終了またはチャンネルアイドル状態が決定される。そのようなシステムの運用が集線処理をサポートしているときこの情報はアイドルチャンネルの割り当てのために利用できる。

等化処理は、チャンネル監視に関して以下にさらに詳細に説明するように未割当または割当済のチャンネルにノイズによる障害があるかどうかを決定するためにも利用できる。

電話伝送システムはいくつかの態様でチャンネルのノイズからの保護を提供する。狭帯域のノイズは外部源から伝送に結合して侵入した狭帯域信号である。OFDM波形内に位置するノイズ信号は全体の帯域をオフラインにする可能性がある。ノ

イズ信号はOFDMキャリアと直交しておらず（もしくはその可能性が高く）、最悪の場合、すべてのOFDMキャリア信号と十分なレベルで干渉しほとんどすべての DSSS+をその性能が最小ビットエラーレート以下に劣化する程度までに障害を与える。

1つの方法は周波数帯域上でのノイズの位置を特定する干渉検知アルゴリズムを含むデジタル的に同調可能なノッチフィルタを設けることである。位置が特定されれば、OFDM波形からノイズを除去するフィルタを提供すべくフィルタが更新される。フィルタは基本モデム動作の一部ではないが、それらを同調により除去する目的で劣化したチャネルの特定を必要とする。干渉の結果として失われたチャネルの量はノイズが実際にいかに多くのチャネルに障害を与えたかを決定するための周波数領域におけるビットエラーレート特性に応じて決定される。

図15の MCC上り受信機レシーバアーキテクチャのノイズフィルタ及びFFT112に関して以前に議論したような他のアプローチは多相フ

ィルタ構造である。システムに対して十分なノイズ保護を提供する一方で、フィルタに関するコストと電力は HDT12に吸収される。すなわち、ISU100における電力消費は増加しない。図20及び図21に関して以前に議論したように好適なフィルタ構造は2つの互い違いになった多相フィルタを含んでいる。1つのフィルタの使用も明らかに含まれているが、その場合いくつかのチャネルが減ることになる。フィルタ/変換の対はフィルタと復調処理を単一のステップに結合する。多相フィルタがもたらす特徴のいくつかは狭帯域のノイズに対して受信帯域を保護することができることと、上り伝送において計測可能な帯域の利用を可能にすることである。これらのアプローチにより、ノイズがいくつかのチャネルを利用不能にするならば、HDT12はノイズを避けるために ISUに対して異なるキャリア周波数上で上り送信をするように指令することができる。

少なくともデジタル的に同調可能なノッチフィルタと多相フィルタの使用を含むノイズ保護に対する上記のアプローチはマルチキャリア転送を利用する1対1システムにも等しく適用可能である。例えば、単一の HDTへ転送する単一の MISUはこの技術を使用できる。さらに、単方向の多対1転送もキイズ保護のために



この技術を利用できる。

さらに、チャンネル監視及びそれに基づく割当または再割当もまたノイズを避けるために使用される。外部変数は与えられたチャンネルの品質に悪い影響を与える可能性がある。これらの変数は無数にあり、電磁干渉から光ファイバの物理的損壊までである。光ファイバの物理的損壊は通話リンクを切断し、チャンネルの切換では避けることはできない。しかしながら、電気的な干渉を受けたチャンネルは干渉がなくなるまで避けることができる。干渉がなくなった後、チャンネルは再び使用することができる。

図28において、チャンネル監視方法は、劣化チャンネルの使用を検出し、それを回避するために用いられる。チャンネルモニタ296は、ボードサポート(BSP)ソフトウェア298からのイベントを受信し、ローカルデータベースのチャンネル品質テーブル300を更新する。また、モニタ296は、割当て又は再割当てのためにメッセージを障害分離器302及びチャンネル割当て器304に送出する。チャンネルモニタへの基本入力は、パリティエラーであって上りDSO+チャンネルのハードウェアから得られる。DSO+チャンネルは、パリティ又は前述したチャンネルに挿入されるデータインテグリティビットを伴う10ビットのチャンネルからなる。特定チャンネルのパリティエラー情報は、生データとして使用され、そのチャンネルの品質ステータスに至る時間を通してサンプルされ、集積される。

パリティエラーは、チャンネルステータスを判断するため、PTOS, ISDN, DDS及びDSIを含む異なるサービスタイプの各々に対して2タイムフレームを使用して集積される。第1の集積ルーチンは、全てのサービスタイプに対し1秒の短い集積時間に基づいて行われる。第2のルーチンは、長い集積が行われ、表3に示すように異なる集積時間と監視期間とを要する種々のサービスに必要とされるエラービットレートとしての、従属サービスである。これらの2つの方法が以下で述べられる。

図29A、29B及び29Cには、基本の短い集積動作を述べている。CXMU56がチャンネルのパリティエラーを検出した時、パリティ割込みはそのパリティ割込み(図29A)より高い割込み優先レベルを設定することによってディセ

ーブルされる。もし、受信信号障害を示すモデムアラームが受信されたなら、パリティエラーはその障害状態が終了するまで無視される。従って、いくつかの障害状態はパリティエラー監視に取って代わる。そのようなアラーム

状態には、信号の消失、モデム障害、そして同期はずれが含まれる。もし、モデム障害が非アクティブなら、パリティカウンタテーブルは更新され、図29Bに示すエラータイムイベントはイネーブルされる。

エラータイムイベントがイネーブルされた時、CXMU56のパリティエラーレジスタが10ミリ秒毎に読み出され、チャンネルモニタ296は1秒監視期間の後にエラーカウンタの集計モードに入る。一般に、エラーカウンタはチャンネル品質データベースを更新し、そしてどのチャンネルが再割当てを要求しているか決定するのに使われる。前記データベースのチャンネル品質テーブル300は各チャンネルの進行中の記録を含む。前記テーブルは、チャンネルに割当てられたカレントISU、監視の開始と終了、全てのエラー、先日、先週、過去30日のエラー、最後のエラーからの秒数、先日、先週、過去30日の重大エラー、そしてチャンネルに割当てられたISDNのような現在のサービスタイプ、のカテゴリにおけるチャンネルの履歴を示す。

図29Aに示すように、パリティ割込みがディセーブルされてアクティブアラームが存在しなくなった後、パリティカウンタは更新され、そしてタイムイベントはイネーブルされる。前記タイムイベント(図29B)は上述したエラーを監視する1秒ループを含む。図29Bに示すように、1秒ループが経過しなければ、エラーカウンタは更新され続ける。それが経過した時にエラー集計がなされる。以下に示すように、前記1秒間に集計されたエラーは、割当てチャンネルの劣化若しくは障害を示す許容量を超えた場合にチャンネル割当て器304に通知され、ISU伝送は異なるチャンネルに再割当てされる。図29Cに示すように、再割当てが完了した時、割込み優先度はパリティより低く設定され、その結果チャンネル監視

が継続し、チャンネル品質データベースは実行されるアクションに応じて更新され

る。再割当てタスクは、エラータイマタスクから独立したタスクとして実行されてもよく、又そのタスクと結合して実行されてもよい。例えば、再割当て器304はチャンネルモニタ296の一部であってもよい。

図29Bのエラータイマタスクの別の実施例である図29Dに示すように、チャンネルは1秒経過前に障害と判断され得る。このことは、1秒間の最初の部分の間に劣化と判断されたチャンネルが、完全に1秒経過するのを待つことなく直ちに定義され再割当てされることを許容する。

再割当てに代えて、チャンネル上のイングレス(ingress)を克服するためにISUによる伝送パワーレベルを増加してもよい。しかしながら、1チャンネル上のパワーレベルを増加するなら、全体のパワーレベルを実質的に一定に維持するために少なくとも他の1チャンネルのパワーレベルを減少させなければならない。

全てのチャンネルが障害となった場合、障害分離器302はファイバの切断等の重大な障害が存在する可能性を通知される。もし、1秒間に集計されたエラーが割当てチャンネルが劣化していないことを示す許容値以下であるなら、割込み優先度はパリティ以下に設定され、エラータイムイベントはディセーブルされる。そのようなイベントはやがて終了し、前記チャンネルは再び図29Aに示すパリティエラーのために監視される。

上述した周期的なパリティ監視によって現われる2つの結果は、チャンネルの劣化を判断する1秒の監視期間に観測されるパリティエラーカウントに対応するビットエラー率を評価するのに重要である。第1はパリティ自体の性質である。ブロックエラー検出に用いられるデータフォーマットの一般的な使用において1つのエラープロ

ックは1ビットのエラーを示すと仮定している。しかしながら、実際にはそのエラーは多数のデータビットを表す。データトランスポートシステムの性質から、変調データに含まれるエラーは、そのデータをランダム化するものと考えられる。このことは、平均エラーフレームは4つのエラーデータビット(第9ビットを除く)から成ることを意味する。パリティでは奇数ビットエラーだけを検出するため、全エラーフレームの半分はパリティによって検出されない。従って、トラ

ンスポートインタフェースによって生じる各パリティ（フレーム）エラーは、8（データ）ビットのエラー平均を示す。第2に、各モニターされたパリティエラーは80フレームのデータ（10ms / 125μs）を表す。パリティエラーはラッチされるため全てのエラーは検出されるが、重複エラーは1つのエラーとして検出される。

チャンネルを再割当てする時を決定する基準としてビットエラーレート（BER）が使用され、 $10^{-3}$ が選択される。従って、 $10^{-3}$ を超えない1秒間のパリティエラー許容数を決定する必要がある。許容可能なパリティエラーを確立するために、各観測（モニター）されたパリティエラーによって表される予想フレームエラー数を予測する必要がある。モニタパリティエラーの数、モニタパリティエラー当たりの推定フレームエラー数、そしてフレーム（パリティ）エラーによって表されるビットエラー数を与えることで、予想ビットエラー率を導出することができる。

統計手法を使って、以下の仮定をする。

1. エラーはポアソン分散を有し、そして
2. モニタパリティエラーの数が全“サンプル”数（100）において小さければ（ $< 10$ ）、モニタパリティエラーレート（MPER）は平均フレームエラーレート（FER）を反映する。

モニタ（監視）パリティエラー（MPE）は、80フレームを表すため、前記仮定2は各パリティエラー“の裏にある”フレームエラー（FEs）数が80MPERに等しいということを意味する。すなわち、サンプル当たり10msの100パリティサンプルに対し、パリティエラー当たりの平均フレームエラー数は1秒間におけるMPEカウントの0.8倍に等しいことになる。例えば、もし3MPEが1秒間に観測されたなら、各MPEに対する平均FEの数は2.4である。所望のビットエラー率をサンプルサイズに掛けること、そしてフレームエラー当たりのビットエラーで割ることはそのサンプルの等価フレームエラー数を与える。FEの数は、またMPEの数とMPE当たりのFEの数との積に等しい。所望のBERを与えることにより、下式の解決策が決定される。

$$\left( MPE \frac{FE}{MPE} \right) = 0.8 MPE$$

以下に示すポアソン分散は、 $MPE(\chi)$ で表される所定のFE数の確立を計算するために使用される。上記仮定2は、 $MPE(\mu)$ 当たりの平均FE数に至るために使用される。

$$P(\chi) = \frac{e^{-\mu} \mu^{\chi}}{\chi!}$$

所望のビットエラー率は最大であるから、0から最大数までの $\chi$ に対する値が首尾よくポアソン式に与えられる。これらの確立の合計は各モニタパリティエラーに対して発生する $\chi$ フレームエラー以下の確立である。

ビットエラー率 $10^{-3}$ そしてフレームエラー当たりのビットエラーが1及び8の結果を表2に示す。

表2: ビットエラー率確立

フレーム当たりのビットエラー	監視パリティエラー	最大フレームエラー/監視パリティエラー ( $\chi$ )	平均フレームエラー/監視パリティエラー ( $\mu$ )	BER < $10^{-3}$ の確率
	2	4	1.6	9.8%
8	3	3	2.4	7.8%
	4	2	3.2	3.8%
	8	8	6.4	8.0%
1	9	7	7.2	5.6%
	10	7	8.0	4.5%

この手法を使って、1秒集積期間中に検出された4個の監視パリティエラーの値も新チャネルに対するISUの再割当てサービスの閾値として決定した。この結果は、フレームエラー当たり8ビットエラーの最悪ケースであり、しかしビットエラー率が $10^{-3}$ より良い3.8%の確立と仮定することによる。フレーム監視パリティエラー当たりのビットエラーと監視パリティエラー当たりの最大フレー

ムエラーとの積は、ビットエラーレート  $10^{-3}$  から 64 でなければならない (64 K ビットで 64 エラー)。従って、エラータイムイベントでパリティエラーのサンプリングが 4 又はそれ以上の時、チャンネル割当て器はチャンネル劣化を通知される。もし、サンプルされた監視パリティエラーが 4 に満たない時は、割込み優先度をパリティより低く設定し、エラータイムイベントをディセーブルしてタイムエラーイベントを終了する。そのチャンネルは 27 A のフロー図に示すように監視される。

以下では、チャンネルモニタ 296 のバックグラウンド監視ルーチン (図 30) によって実行される長い集積動作について述べる。前記バックグラウンド監視ルーチンは、短い集積  $10^{-3}$  ビットエラー率より

も高品質を必要とするチャンネル品質の完全性を保証するのに用いられる。図 30 のフロー図が示すように、バックグラウンド監視ルーチンは、各サービスタイプの特定期間に動作し、チャンネル品質データベーステーブル 300 を更新し、バックグラウンドカウントをクリアし、集積エラーが各サービスタイプで決められた許容範囲を超えたか否かを判断し、そして必要なら障害チャンネルのチャンネル割当て器 304 に通知する。

1 秒期間の動作中、バックグラウンドモニタはチャンネル品質データベーステーブルを更新する。前記チャンネル品質データベーステーブルの更新には 2 つの目的がある。第 1 の目的は、エラーフリーチャンネルのビットエラーレートとエラー秒データ数とを調整し、それらを品質の向上に反映させることである。第 2 の目的は、非常に低いエラーレベル (4 パリティエラー / 秒以下) のために短い集積時間再割当てとなる監視チャンネルの間欠エラーを集積することである。この範疇のチャンネルは、その BER と調整されたエラー秒データ数とを有し、そのデータに基づいて再割当てされる。このことは長い集積時間再割当てとして知られており、以下に各サービスタイプに対する長い集積時間再割当ての初期基準を示す。

表 3

サービス タイプ	最大 BER	集積 時間	エラー 秒	監視 周期
POTS	$10^{-3}$	1秒		
ISDN	$10^{-6}$	157秒	8%	1時間
DDS	$10^{-7}$	157秒	0.5%	1時間
DSI	$10^{-9}$	15,625 秒	0.04%	7時間

POTSサービスは、 $10^{-3}$ 以上の高品質を必要としないため、劣化チャンネルは短い集積手法を用いて十分除去でき、長い集積は必

要としない。

あるサービスタイプの長い集積の一例として、バックグラウンドモニタをISDNトランスポートに使用するチャンネルと関連して述べる。前記チャンネルの最大ビットエラー率は $10^{-6}$ であり、集積時間に利用される秒数は157、許容可能な最大エラー秒数は157秒の8%、そして監視期間は1時間である。従って、どの1時間の監視期間においてもエラー秒の合計が157秒の8%より大きければ、チャンネル割当て器304にISDNトランスポートのチャンネル障害を通知する。

非割当て又は未使用チャンネルであるが初期化され活性化されているものは、TR-8のような非集中(non-concentration)サービスに対する再割当てのために使用され、又はTR-303のような集中サービスに対する割当てや再割当てのために使用されるかにより、それらが障害でないことを保証する監視が必要となる。チャンネルモニタ304は、非割当てチャンネルを監視するためバックアップマネージャルーチン(図31)を使用し、割当て又は再割当ての決定に用いられるエラーデータを集積するためにループに非割当てチャンネルを設定する。非割当てチャンネルがエラーとなった時に1時間はそれをISU100に割当てない。前記チャンネルが1時間のあいだアイドル(非割当て)を維持した後、チャンネルモニタは前記チャンネルをループバックモードに設定し、そのチャンネルが回復したか否かを検査する。ループバックモードにおいて、CXMU56は、初期化され活性化さ

れたISU100に対し、パリティエラーの短い又は長い集積を実行するのに十分な長さのチャネルに関するメッセージを適宜送出するよう命ずる。ループバックモードにおいて、先に劣化したチャネルが回復時間を経過し、それによってチャネル品質データベースが更新されたか否かを判断することができる。ループバックモード以外では、そのようなチャネルをパワーダウンすることができる。

上述したように、チャネル品質データベースは再割当て又は割当てを許可するか否かの情報を含み、再割当て又は割当てはそれに用いられるチャネルが劣化しないようになされる。さらに、前記チャネル品質データベースの情報は、非割当てチャネルが有効に割当てられるように品質に基づいて非割当てチャネルをランク付けする利用のしかたも可能である。例えば、あるチャネルは、PTOSに対して十分であり、ISDNに対しては十分でないとしてもよい。別に追加されたチャネルは両者に十分としてもよい。前記追加されたチャネルは、ISDNに使用されるがPTOSに使用されないものであってもよい。さらに、高品質な特定の待機チャネルを配し、イングレスが非常に大きな時に、常に切り替えるべき1つのチャネルを入手できるようにしてもよい。

さらに、図15に示すMCCモデム82の上りレシーバアーキテクチャのイコライザ214を利用した非割当て及び割当てチャネルの両者に対し、信号対雑音比の評価が決定される。先に述べたように、初めにチャネルが割当て可能なアイドルか否かを判断するのにイコライザが利用される。イコライザの動作中、イコライザの係数を更新すべくエラーが生成される。エラーの大きさはマッピングされ、信号対雑音モニタ305(図15)によって信号対雑音比(SNR)が評価される。また、未使用チャネルはその帯域内に信号を有してはならない。従って、未使用のFFTビン(bin)内で検出された信号の変化を検出し、信号対雑音比の評価が決定される。信号対雑音比の評価は推定ビットエラーレートに直接関係するため、前記推定ビットエラーレートは障害又は正常なチャネルの存在を判断するチャネル監視に利用される。

よって、TR-8のような非集中サービスの再割当てのためループバックモー



ドで監視される非割当てチャンネル等を伴う非割当てチャンネルに対し、又はイコライザの利用によるSNR評価によって再割当てが実行される。同様に、TR-303のような集中サービスの割当て又は再割当てが、イコライザの使用によるSNR評価により決定された非割当てチャンネル等の品質に基づいて非割当てチャンネルに対して実行される。

チャンネル割当てに関し、チャンネル割当て器304のチャンネル割当て器ルーチンは、チャンネル品質データベースを検査し、要求されたサービスのためにどのDSO+チャンネルをISU100に割当てるかを決定する。チャンネル割当て器は、またISUのステータスとチャンネルユニットとをチェックし、要求されたサービスに対するサービス提供中のステータス及び適当なタイプを確認する。チャンネル割当て器は、チャンネル再割当ての柔軟性を許容すべくISU100における最適な帯域分散を維持する。

ISUs100、少なくともHISU、は、どの所定時間でもRF帯域部分だけでアクセスできることが好ましい。チャンネル再割当て器は、前記ISUのチャンネル使用を分散し、それによて帯域の一部が過負荷とならず、付加チャンネルの空きが生じないようにサービス中チャンネルの再割当てを回避する必要がある。

チャンネル割当て器304で使用されるプロセスは、各ISUタイプの同じ番号を6MHzスペクトルの各チャンネル帯域に割当てる。現在のISU帯域が満杯で且つ新たなサービスがそのISUに割り付けられた場合、もし必要ならISUで使用中のチャンネルを新たな帯域に移動させることができる。同様に、1つの帯域でISUが使用するチャンネルが劣化した場合、前記ISUは別のサブ帯域またはチャンネル帯域にチャンネルを再割当てすることができる。分散したI

OCチャンネルがHDT12とHISUとしてのHISUsとの間の通信を許可し続けるため、IOCチャンネルの1つはそのスペクトルにわたって分散される。一般に、最も長い低エラーレートの履歴を有するチャンネルが最初に使用される。そして、障害と判定されその後監視のために再割当てされたチャンネルは、最も長い期間中低いエラー状態で動作してきたチャンネルよりもその履歴が短いため、最後に使用される。

### 電話トランスポートシステムの第2の実施例

図24-27を参照して、OFDM電話トランスポートシステムの第2の実施例について説明する。図24は、6MHzスペクトル割当てを示している。6MHz帯域幅は、9つの個々のモデム226（図25）に対応して9チャンネル帯域に分割される。当業者なら、同一動作を結合することによってより少ないモデムが使用できることが分かる。各チャンネル帯域は、シンボル当たり5ビットからなる直交32アレイフォーマット（QAM32）で変調された32チャンネルを含んでいる。1つのチャンネルは、転送動作をサポートし、HDT12とISUS100との間の通信データを制御するために割当てられる。このチャンネルは、BPSK変調を使用する。

トランスポートアーキテクチャについて、初めに下り伝送について述べ、次に上り伝送について述べる。

図25を参照して、HDT12のMCCモデム82のアーキテクチャについて述べる。下り方向において、シリアル電話情報と制御データがシリアルインタフェース236を介してCXC80から与えられる。前記シリアルデータは、復号器238によって復号化されてパラレルデータストリームとなる。前記パラレルデータストリームは、シンボルマッピングと高速フーリエ変換（FFT）機能を実行する32チャンネルモデム226バンクに与えられる。32チ

ャネルモデムは時間領域サンプルを出力し、それはシンセサイザ230によって駆動される1組のミキサ240を通過する。ミキサ240は、直交する1組の周波数帯域を生成し、各帯域は次にフィルタ/合成器228を通して濾波される。フィルタ/合成器228の集合出力はシンセサイザ242及びミキサ241によって最終送信周波数にアップコンバートされる。その信号は、フィルタ232によって濾波され、アンプ234によって増幅され、そして全てのノイズを除去するためにフィルタ232によって再び濾波される。前記信号は、電話トランスミッタ14を介してHFC分散ネットワーク上に結合される。

HFC分散ネットワーク11の下り終端部において、ISU100は図26に示す加入者モデム258を有する。下り信号は、同軸レグ(leg)30を通して0

D N 1 8 から受信され、完全な 6 M H z 帯域を選別するフィルタ 2 6 0 によって  
濾波される。次に、前記信号は 2 つの部分に分離される。第 1 の部分はシステム  
クロックに同期するための制御データとタイミング情報とを与える。第 2 の部分  
は電話データを与える。電話データから分離して受信された制御データは、帯域  
I S U の出力として先に言及している。B P S K 変調された帯域制御チャネルの  
出力は、ミキサ 2 6 2 によって混合されてベース帯域となる。その信号は次にフ  
ィルタ 2 6 3 によって濾波され、自動利得制御段 2 6 4 とキャリア位相を回復す  
るコスタス(Costas)ループ 2 6 6 とを通過する。その信号はタイミングループ 2  
6 8 に渡され、その結果タイミングは完全なモデム用として回復される。コスタ  
スループの副産物である I O C 制御データは、I S U 1 0 0 の 3 2 チャンネル O F  
D M モデム 2 2 4 に与えられる。下り O F D M 波形の第 2 の部分は、ミキサ 2 7  
0 及び関連するシンセサイザ 2 7 2 によって混合されてベース帯域となる。ミキ  
サ 2 7 0 の出

力はフィルタ 2 7 3 によって濾波され、受信に備える利得制御段 2 7 4 を通過す  
る。そして、その信号は、3 2 チャンネル O F D M モデム 2 2 4 に渡される。

図 2 7 において、I O C 制御データは機能ブロック 2 7 6 によってハードリミ  
ットされ、マイクロプロセッサ 2 2 6 に与えられる。O F D M 電話データは、ア  
ナログ-ディジタル変換機 2 7 8 を通過し、それを記憶するファーストインーフ  
ァーストアウト・バッファ 2 8 0 に入力される。前記データの十分な情報量が記  
憶された時に、前記データはマイクロプロセッサ 2 2 6 に与えられる。前記マイ  
クロプロセッサは F F T の適用を含む復調プロセス要求を発する。マイクロプロ  
セッサ 2 2 6 は、受信データと受信データクロックインタフェースを介して前記  
受信したデータをシステムの空き部分に与える。高速フーリエ変換 ( F F T ) エ  
ンジン 2 8 2 はマイクロプロセッサとは別に実装される。しかしながら、当業者  
が理解しているように、F F T 2 8 2 はマイクロプロセッサ 2 2 6 によっても実  
行し得る。

上り方向において、データは送信データポートを介して 3 2 チャンネル O F D M  
モデム 2 2 4 に与えられ、そしてマイクロプロセッサ 2 2 6 によってシンボルに

変換される。これらのシンボルは、FFTエンジン282を通過し、その結果ガードサンプルを含む時間領域波形は複合ミキサ284に与えられる。複合ミキサ284はその波形を混合して周波数アップコンバートし、その信号はランダムアクセスメモリ・デジタル-アナログ変換機286(RAMDAC)を通過する。RAMDACは、サンプルがISU上りトランスミッタ(図26)のアナログ部へ与えられる前にそれを記憶するRAMを含む。図26を参照すると、上り伝送のOFDM出力は、フィルタ288によって濾波される。その波形は次にミキサ290を通

過し、シンセサイザ291の制御によって混合されて送信周波数までアップコンバートされる。前記信号はプロセッサ利得制御292を通過し、ここではその信号の振幅レベリングが上りパス上で実行される。前記上り信号は、ODN18へ至る同軸レグ30上に上り伝送する前に、最終選択を行う6MHzフィルタ294を通過する。

HDT12側の上り方向において、電話レシーバ16から同軸上で受信される信号はフィルタ244によって濾波され、増幅器246によって増幅される。直交周波分割多重された受信信号は、ミキサ248バンク及び関連するシンセサイザ250によって混合され、ベース帯域となる。ミキサ248の各出力は次にベース帯域・フィルタバンク252によって濾波され、各出力時間領域波形は32チャンネルOFDMモデム226の復号器に送られる。前記信号はFFTを通過し、そのシンボルはビットにマップバックされる。前記ビットはマルチプレクサ254によって多重化され、他のシリアルインタフェース256を介してCXMC56に与えられる。

本実施例で示したように、ISUは帯域ISUの出力であり、制御データと電話データの分離受信の利用はそのことを示す。さらに、スペクトルはチャンネル帯域に分離される。トランスポートシステムの関連クレームによって実現される種々の他の実施例は、ここで述べられた実施例を構築することで可能となる。1つの実施例において、少なくとも同期情報トランスポートするIOC制御チャンネル及び電話サービスチャンネル又はパスは、単一のフォーマットとして与えられる。H

D T 1 2 と I S U s 1 0 0 との間の I O C リンクは 1 6 K b p s で動作する 4 B P S K 変調キャリア、全体として 6 4 K b p s 、によって実現してもよい。各加入者は、第 2 の実施例のように簡易な分離トランシーバを備え、電話チャンネルから分離された

下りリンク上でそれに割り付けられたサービスチャンネルを継続して監視してもよい。このトランシーバは、サービス I O C に合わせるため調節された発振器を必要とするかもしれない。同様に、I O C チャンネルは 6 M H z 帯域のチャンネル帯域を与え、そのチャンネル帯域は電話データと I O C チャンネルの直交キャリアを含んでもよい。前記 I O C チャンネルはその直交キャリアの受信により分離されて受信される。

4 B P S K チャンネルに代え、他の実施例では単一の 6 4 K b p s I O C チャンネルが提供される。この単一チャンネルは、そのシンボルレートが O F D M フレームネットワークの電話シンボルレートと一致しない。しかしながら、O F D M 周波数構成の上に存在する。この単一の広帯域信号は I S U 1 0 0 において、H D T 1 2 と I S U s との間の I O C リンクを常に可能とするより広い帯域レシーバを必要とする。単一チャンネルサポートでは、固定の基準発振器が使用可能であり、加入者ユニットにおけるどんな帯域部分の調節も必要としない。しかしながら、I O C チャンネルが狭帯域レシーバを考慮したスペクトルに分散される第 1 の実施例とは異なり、I S U 1 0 0 で広帯域レシーバを使用するには本実施例で要求されるパワーが増加する。

さらに他の実施例において、I O C リンクは、3 2 O F D M チャンネルグループの各々について 2 つの I O C チャンネルを有してもよい。これによって各グループにおける O F D M キャリアの数は 3 2 から 3 4 に増加する。各チャンネルグループは 3 4 O F D M チャンネルで構成してもよく、チャンネル帯域は 8 から 1 0 チャンネルグループを含んでもよい。このアプローチは、O F D M 波形を利用するため H D T 1 2 によって与えられる基準パラメータにロックするのに狭帯域レシーバを使用可能とする。しかしながら、O F D M データバース

フォーマットにおける制御又はサービス情報を与えなければならないという複雑性を付加する。なぜなら、加入者はどんなチャネルグループの1つにも調節できるが、エクストラキャリアに埋め込まれた情報は局側で追尾する必要があるからである。そのシステムはタイミング取得要求をサポートするために、本実施例において同期信号がOFDM波形終端から離れて配置されることを要求する。

本発明の多くの特徴は発明の詳細な構成及び機能と共に上述してあり、その開示は例証であって順序、形状、サイズ、構成部分、そして動作における様々なプロパティの変更は発明の要旨の範疇に含まれる。そして、クレーム内容は、その用語の広い一般的な意味によって最大限に拡張される。

【 図 1 】

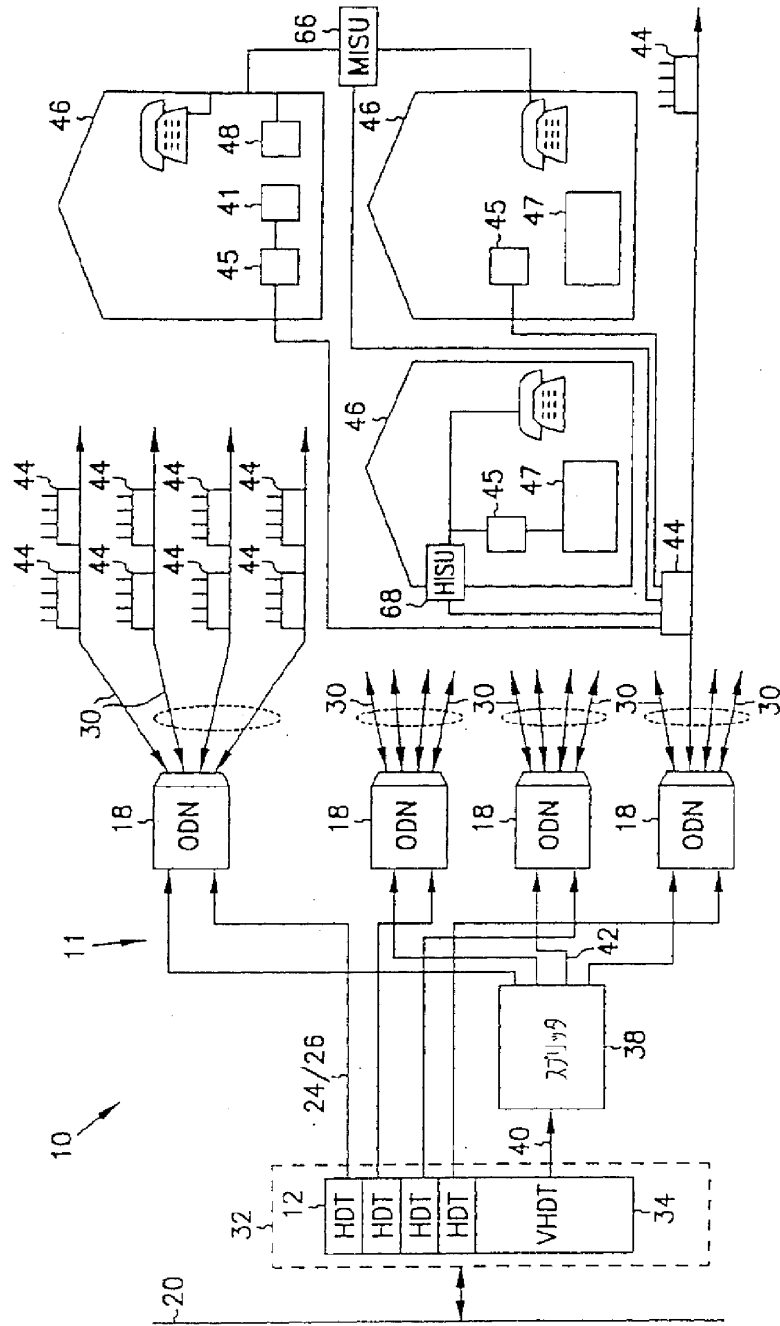

FIG. 1

【図2】

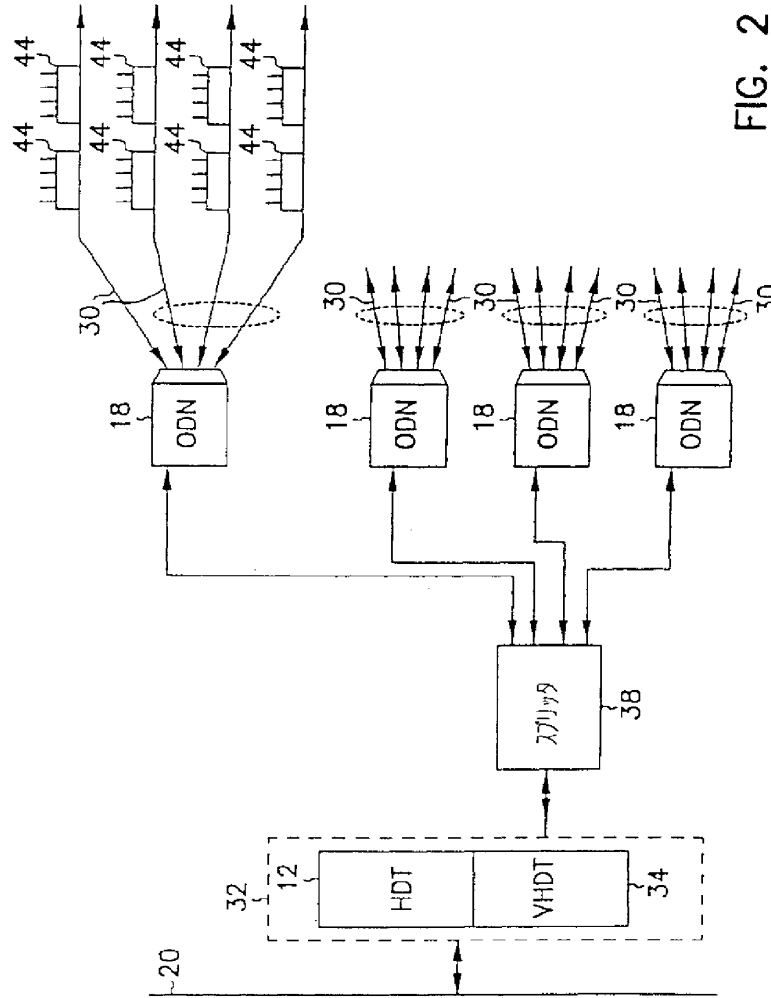

FIG. 2



【図3】

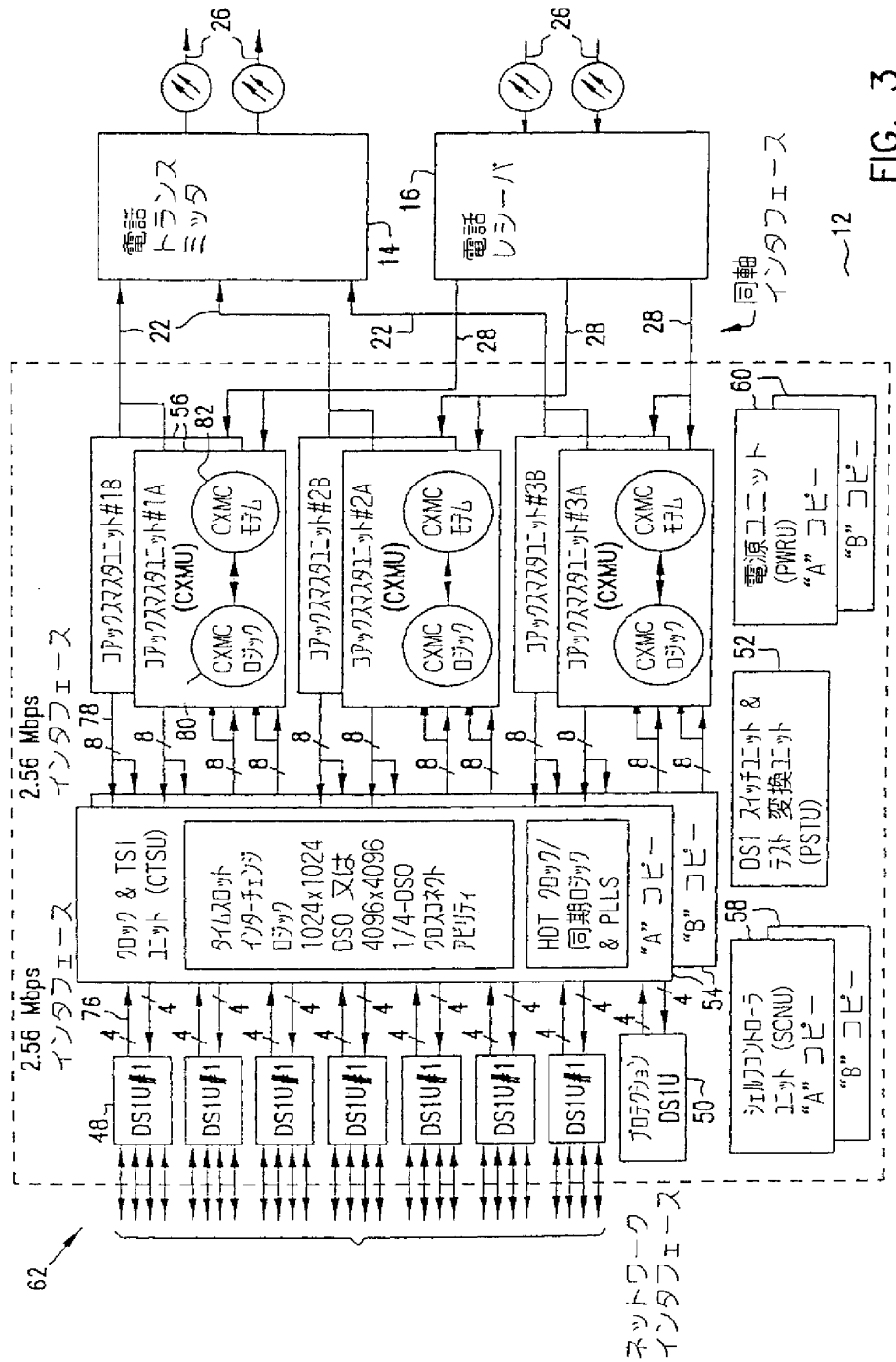

FIG. 3

【図4】

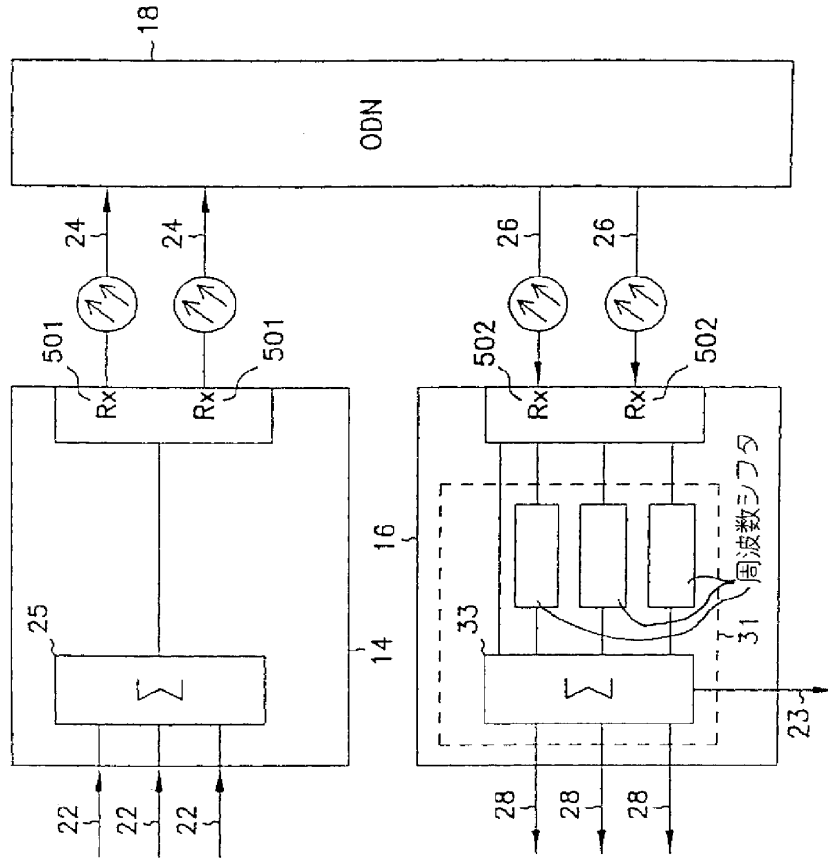

FIG. 4

【図5】

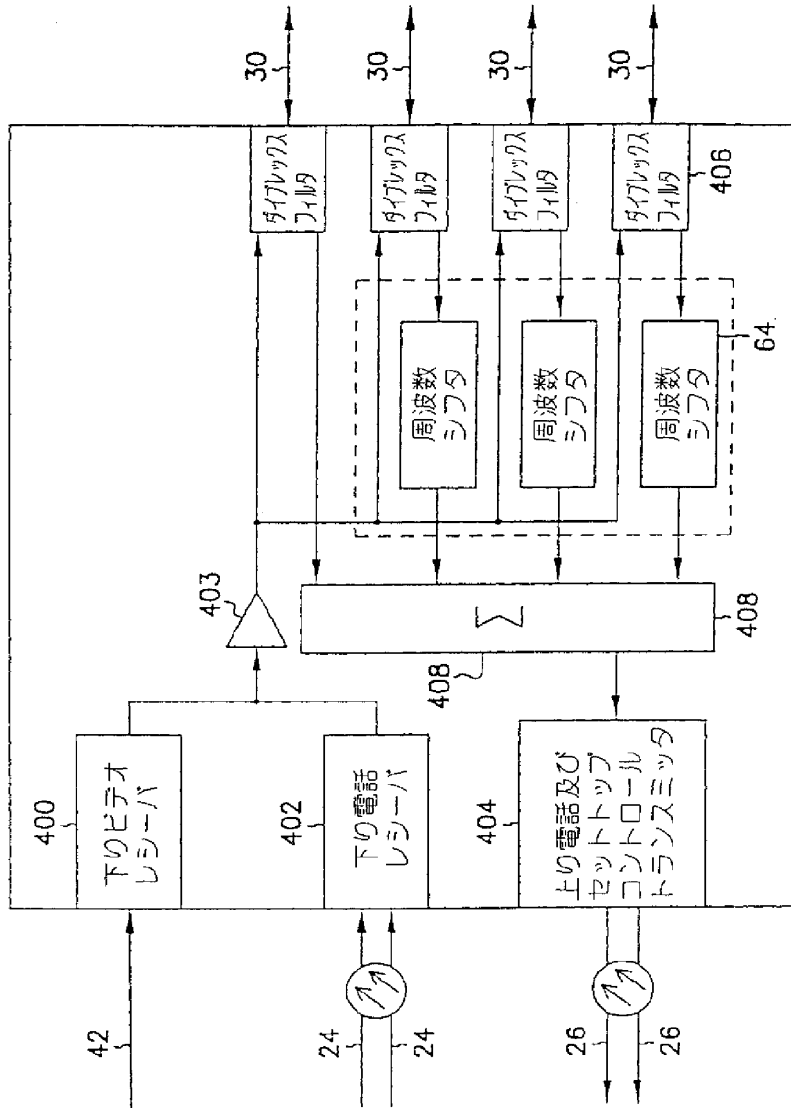

FIG. 5

【図6】

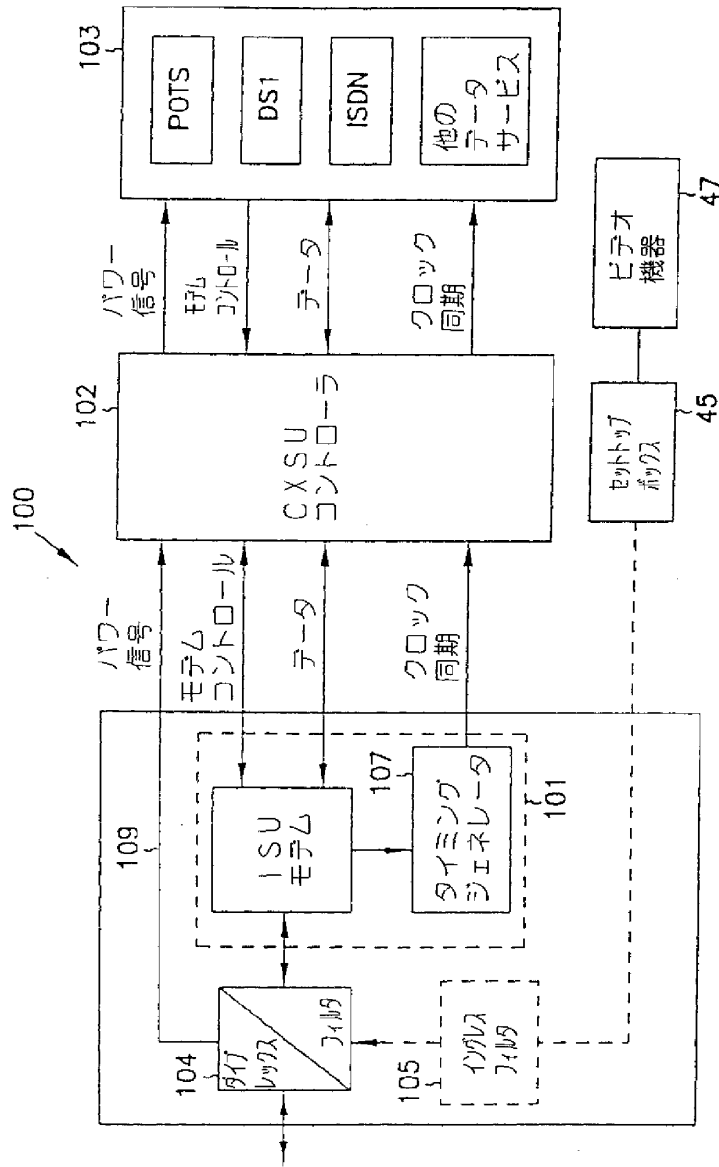

FIG. 6

【図7】

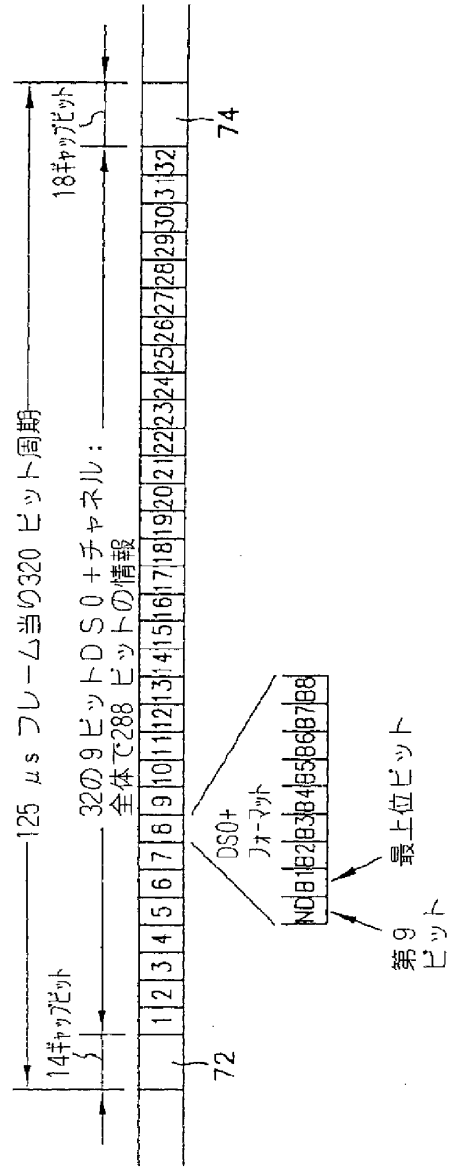

FIG. 7A



【図7】

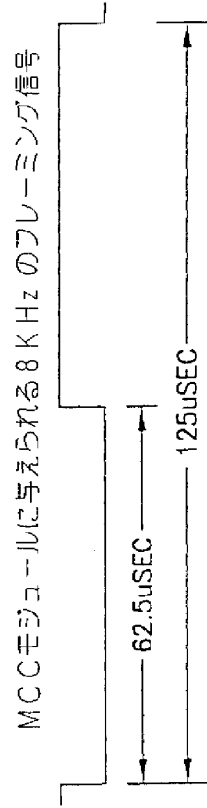

FIG. 7C

【図8】

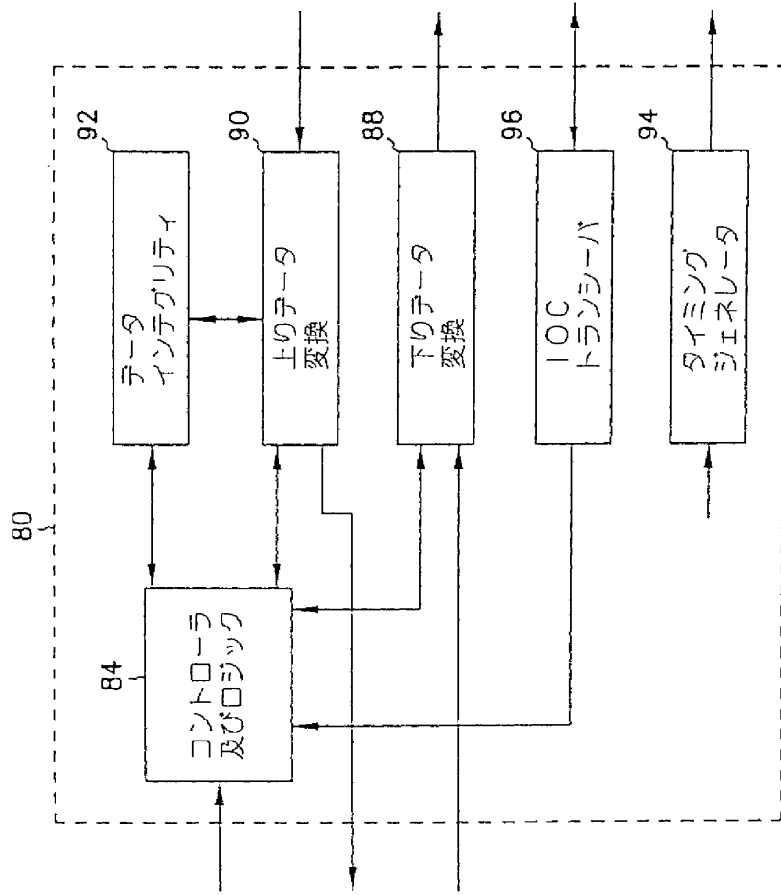

FIG. 8



【図9】

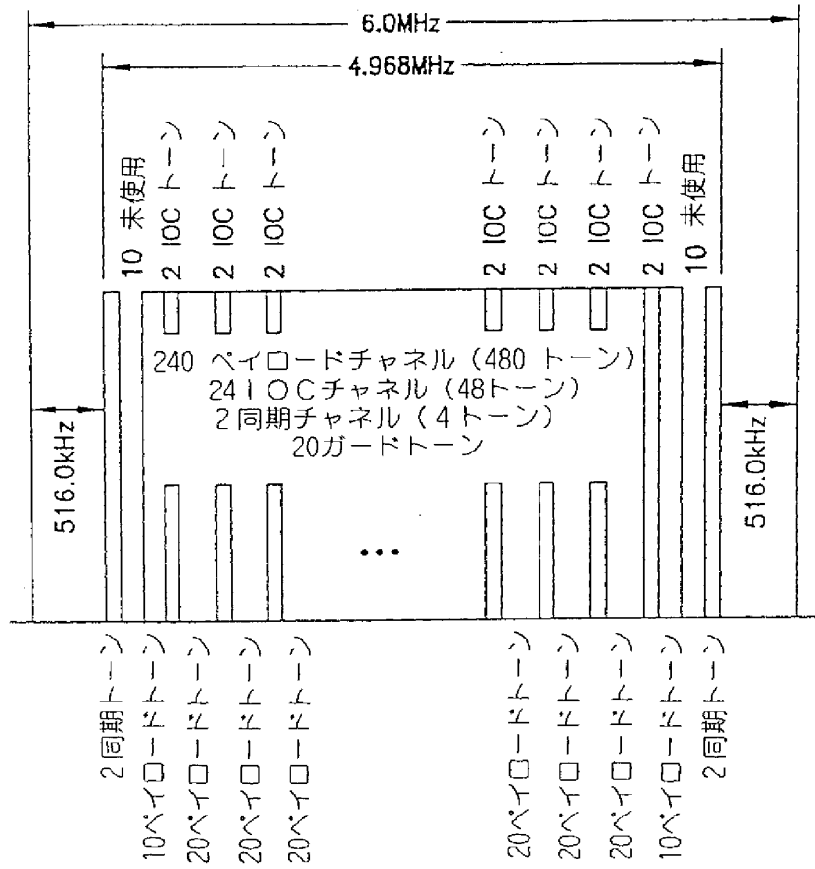

FIG. 9A

【図9】

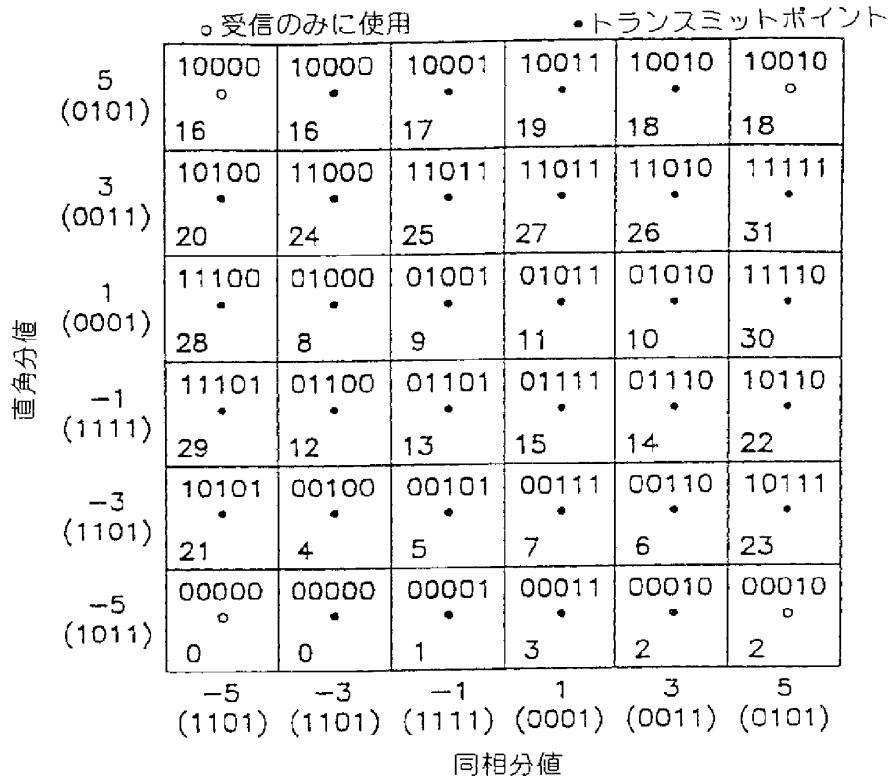

FIG. 9B

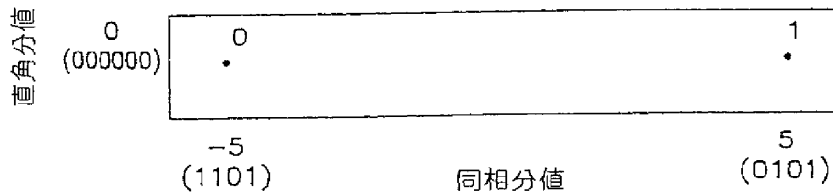
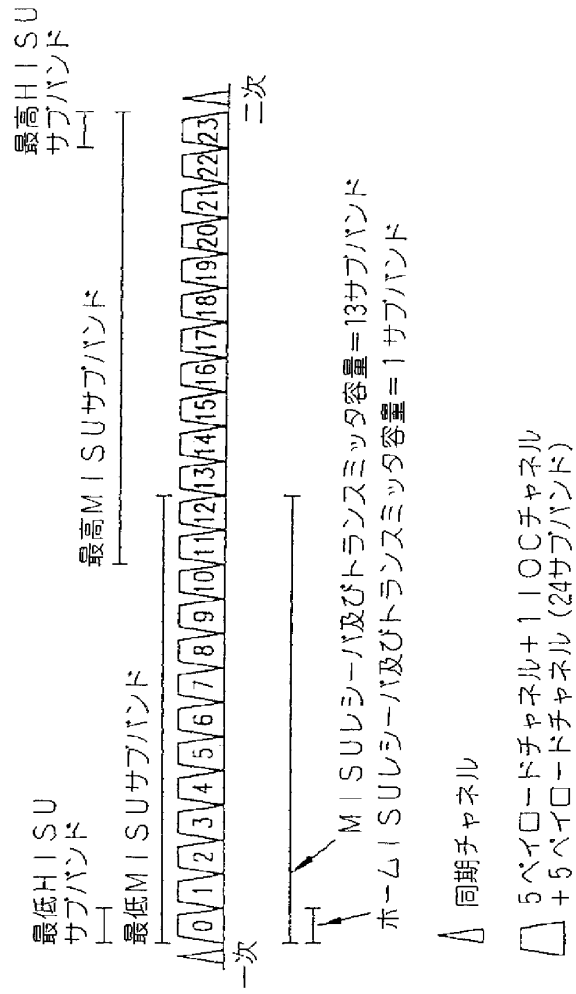

FIG. 9C

【図9】



(108)

特表平10-513622

FIG. 9D

【図10】

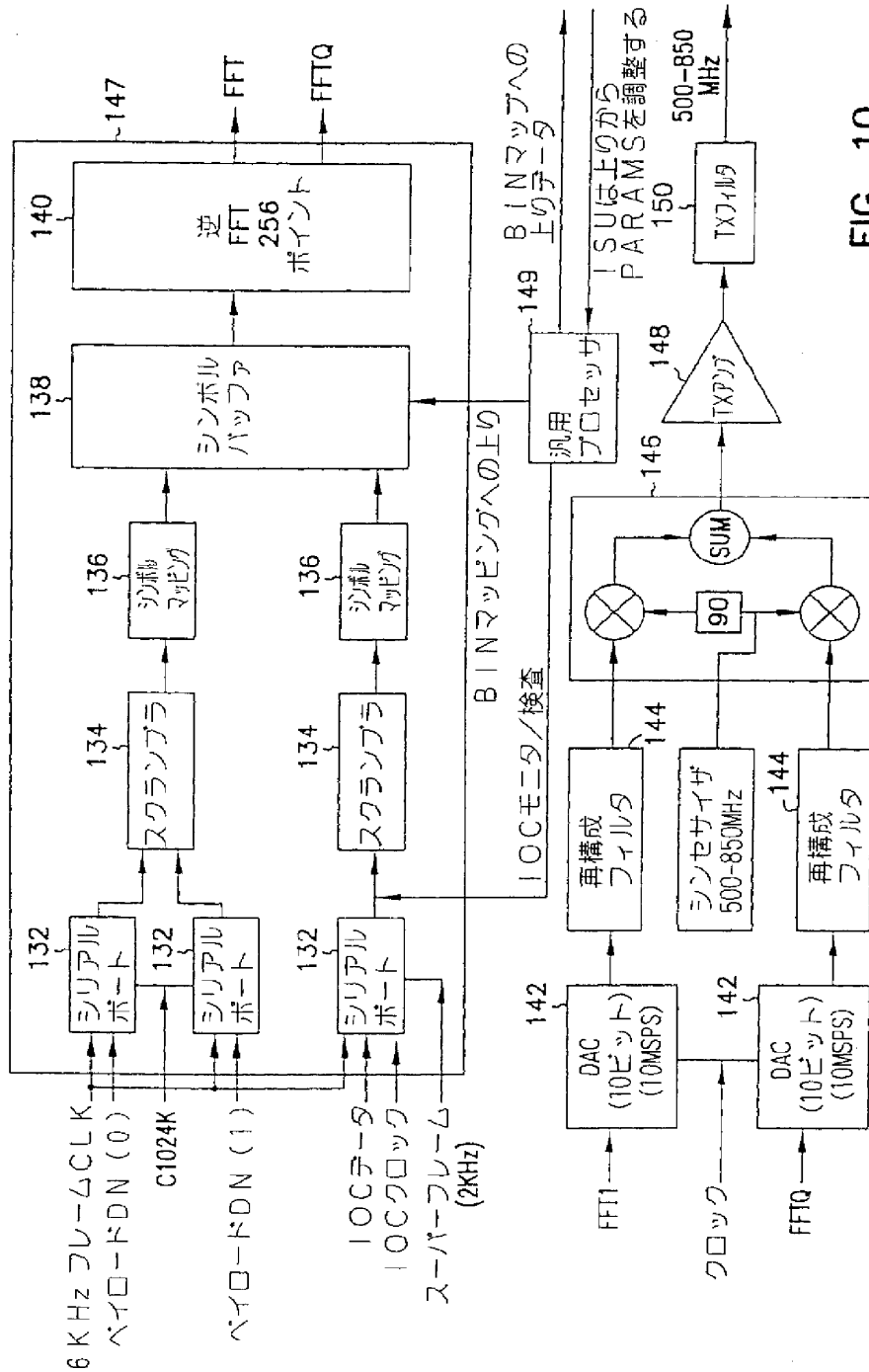

FIG. 10