

【図4】

FIG. 4B

図4aのステップ426から

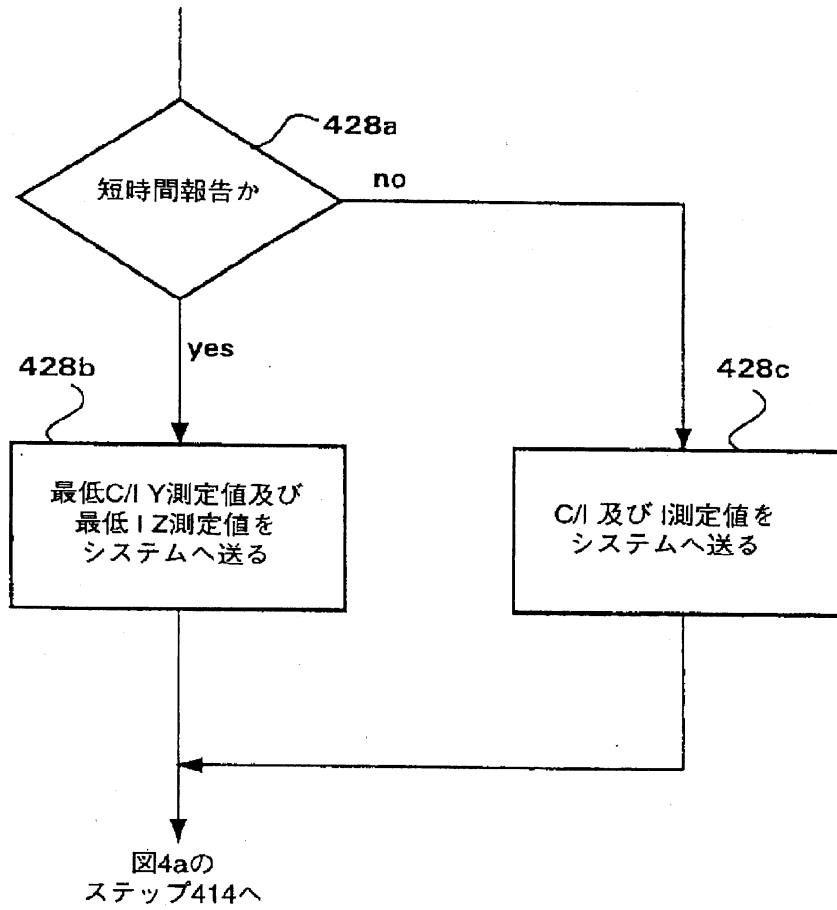

【図5】

FIG. 5

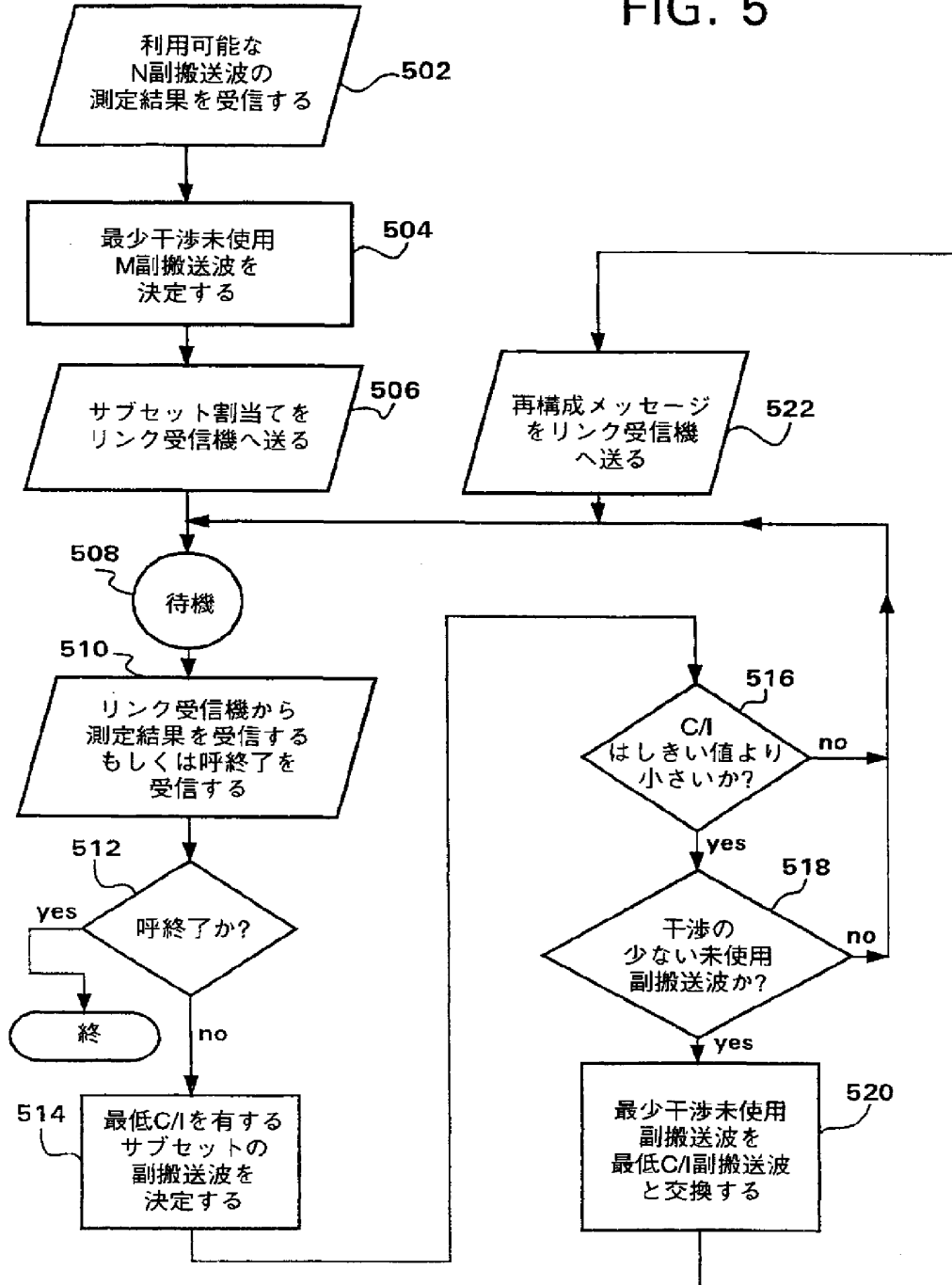

【図6】

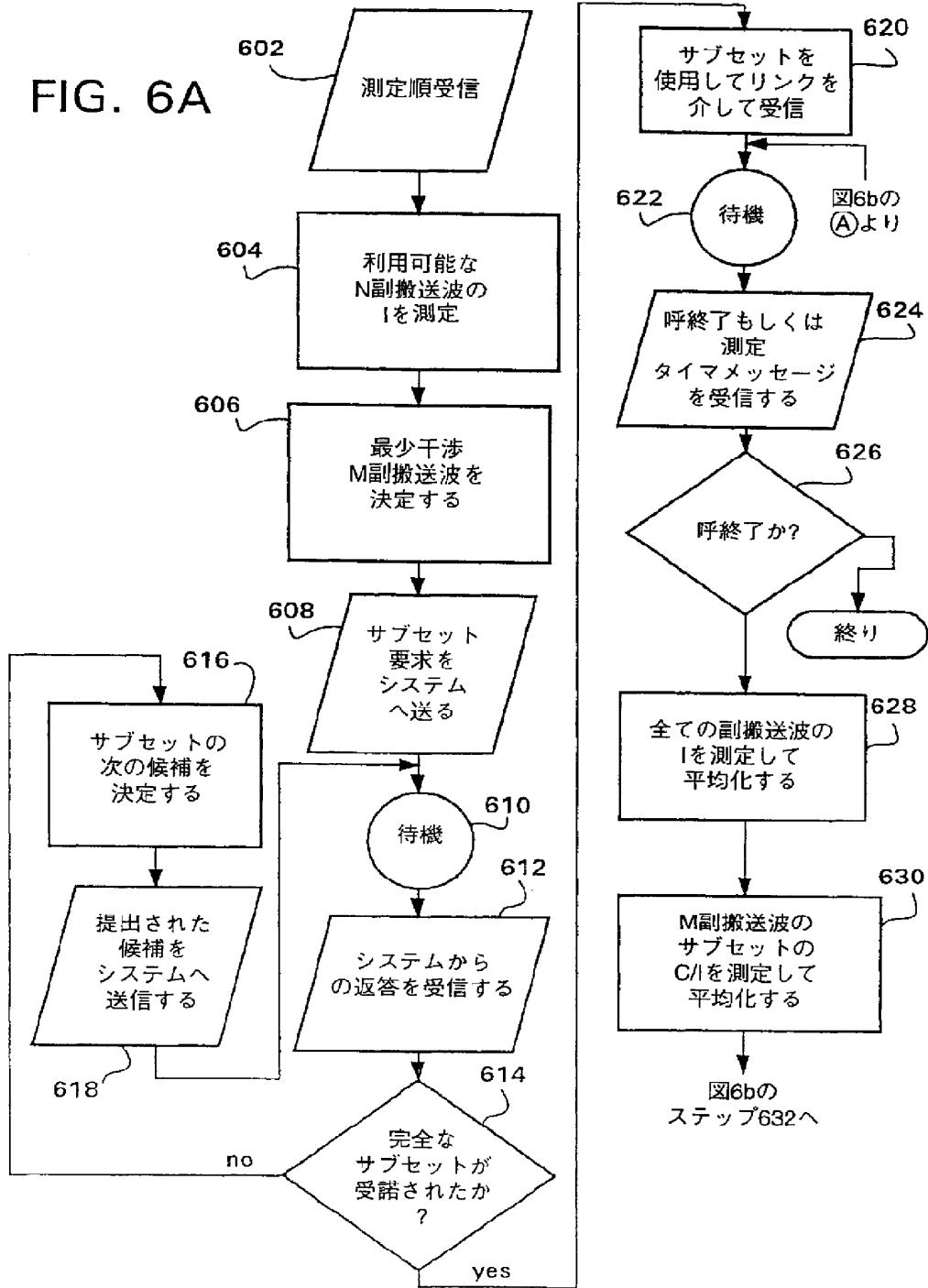

【図6】

図6aのステップ630より

FIG. 6B

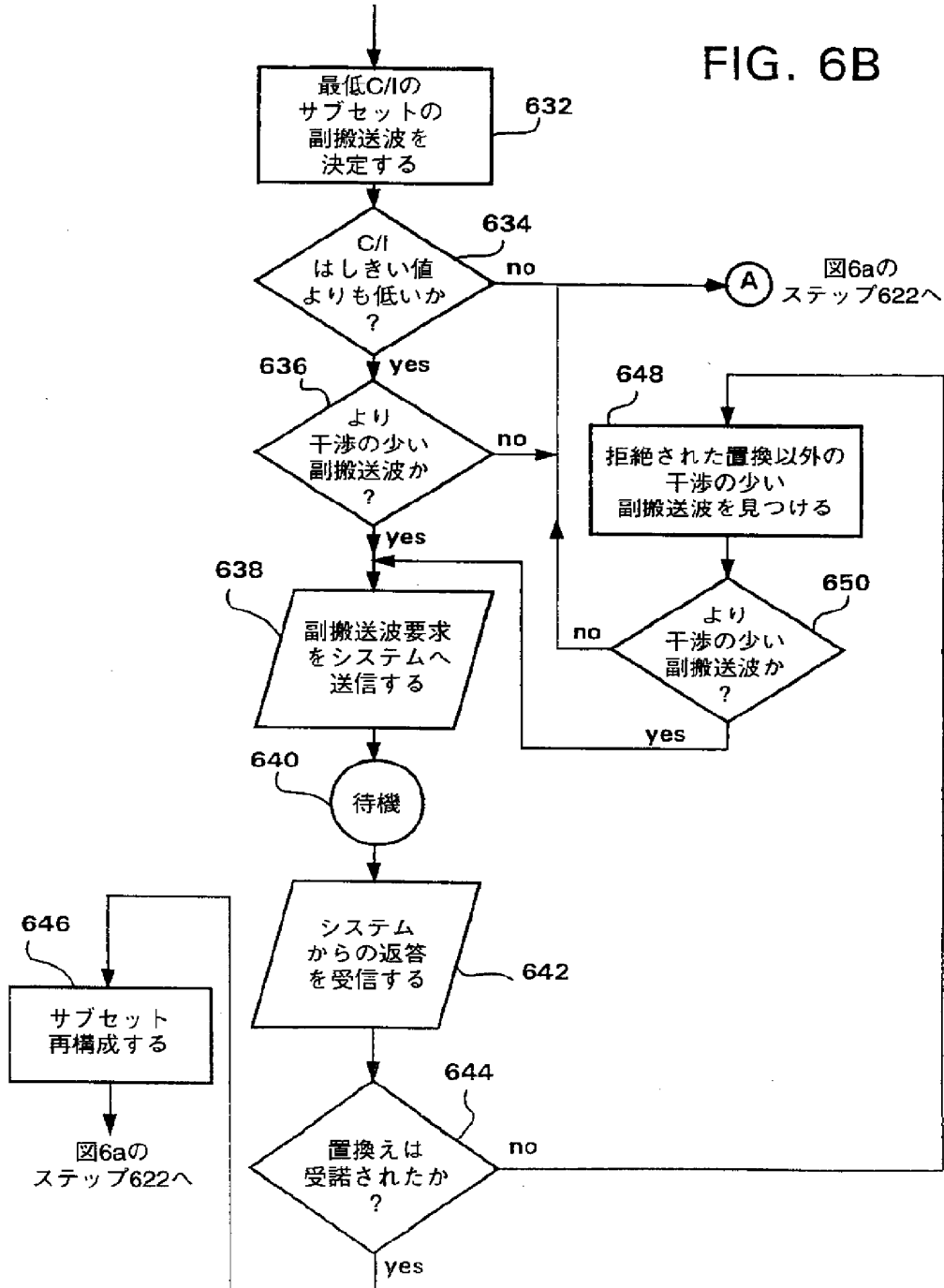

【図7】

FIG. 7

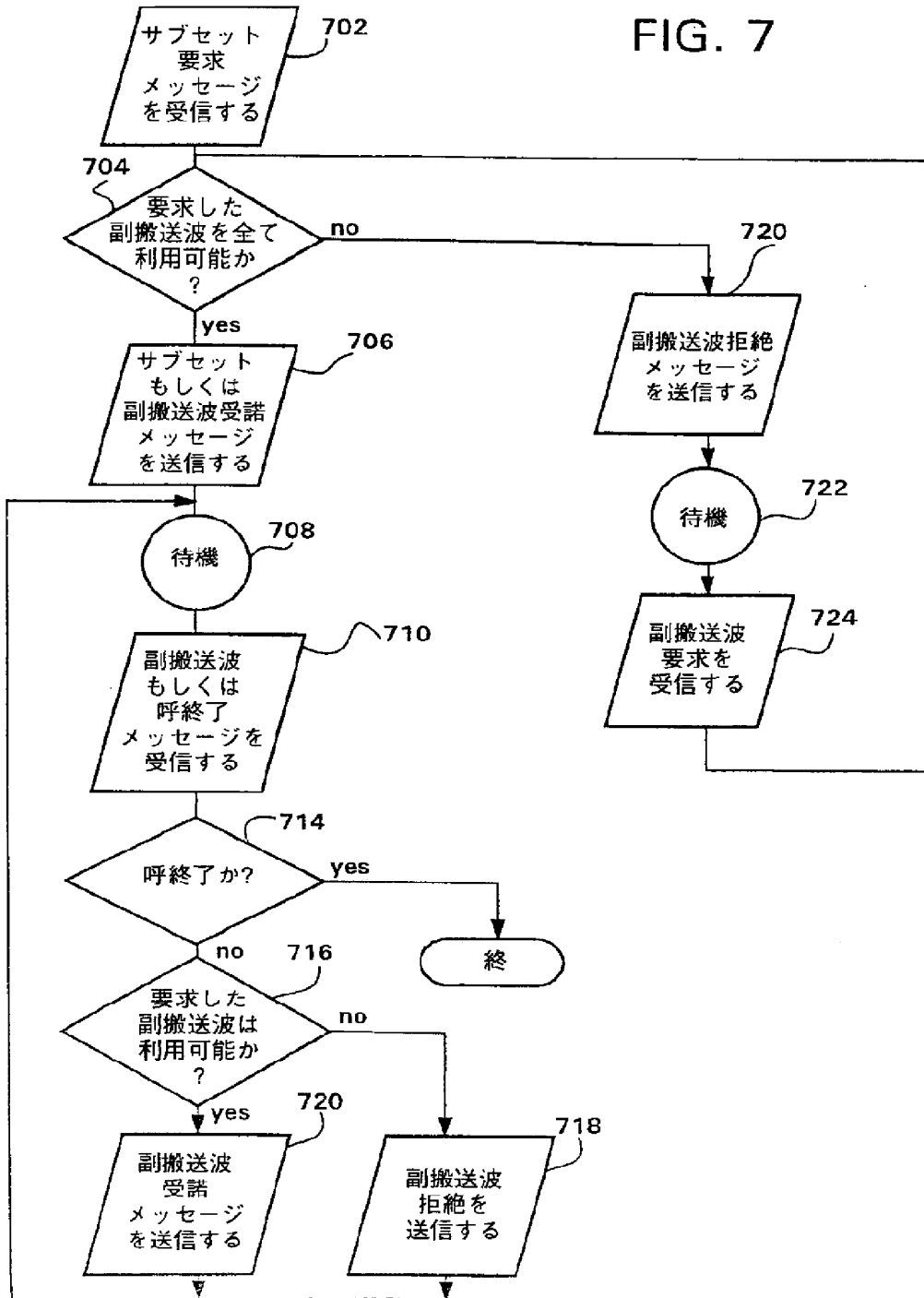

【国際調査報告】

## INTERNATIONAL SEARCH REPORT

		International Application No PCT/SE 96/00814
A. CLASSIFICATION OF SUBJECT MATTER IPC 6 H04Q7/38 H04L5/06		
According to International Patent Classification (IPC) or to both national classification and IPC		
B. FIELDS SEARCHED Minimum documentation searched (classification system followed by classification symbols) IPC 6 H04Q H04L		
Documentation searched other than minimum documentation to the extent that such documents are included in the fields searched		
Electronic data base consulted during the international search (name of data base and, where practical, search terms used)		
C. DOCUMENTS CONSIDERED TO BE RELEVANT		
Category *	Citation of document, with indication, where appropriate, of the relevant passages	Relevant to claim No.
X	WO,A,95 10144 (TELJA AB ;ENGSTROEM BO (SE); LARSSON ROGER (SE)) 13 April 1995 see the whole document ---	1-10, 14-23
A	US,A,5 295 138 (GREENBERG A FREDERICK ET AL) 15 March 1994 see claims ---	1-26
A	US,A,5 400 322 (HUNT RONALD R ET AL) 21 March 1995  see column 1, line 31 - column 3, line 63 ---	1-5, 8-10, 14-18, 21-23
A	EP,A,0 637 181 (SIEMENS AG) 1 February 1995 see the whole document ---	1-5, 14-18
	-/--	
<input checked="" type="checkbox"/> Further documents are listed in the continuation of box C.		<input checked="" type="checkbox"/> Patent family members are listed in annex.
* Special categories of cited documents :		"T" later document published after the international filing date or priority date and not in conflict with the application but cited to understand the principle or theory underlying the invention
"A" document defining the general state of the art which is not considered to be of particular relevance		"X" document of particular relevance; the claimed invention cannot be considered novel or cannot be considered to involve an inventive step when the document is taken alone
"E" earlier document but published on or after the international filing date		"Y" document of particular relevance; the claimed invention cannot be considered to involve an inventive step when the document is combined with one or more other such documents, such combination being obvious to a person skilled in the art.
"L" document which may throw doubts on priority claim(s) or which is cited to establish the publication date of another citation or other special reason (as specified)		"&" document member of the same patent family
"O" document referring to an oral disclosure, use, exhibition or other means		
"P" document published prior to the international filing date but later than the priority date claimed		
Date of the actual completion of the international search	22 October 1996	Date of mailing of the international search report 12.11.96
Name and mailing address of the ISA European Patent Office, P.B. 5818 Patentlaan 2 NL - 2280 HV Rijswijk Tel. (+ 31-70) 340-2040, Tx. 31 651 epo nl, Fax: (+ 31-70) 340-3016	Authorized officer Janyszek, J-M	

Form PCT/ISA/210 (second sheet) (July 1992)

## INTERNATIONAL SEARCH REPORT

International Application No.  
PC1/SE 96/00814

C.(Continuation) DOCUMENTS CONSIDERED TO BE RELEVANT		
Category	Citation of document, with indication, where appropriate, of the relevant passages	Relevant to claim No.
A	ELECTRONICS LETTERS, 27 OCT. 1994, UK, vol. 30, no. 22, ISSN 0013-5194, pages 1831-1832, XP000490811 CHAN C -K ET AL: "Efficient frequency assignment scheme for intermodulation distortion reduction in fibre-optic microcellular systems" see the whole document ---	1-7, 14-18,20
A	EP,A,0 490 599 (NORTHERN TELECOM LTD) 17 June 1992 see the whole document -----	1-8, 14-22

Form PCT/ISA/210 (continuation of second sheet) (July 1992)

## INTERNATIONAL SEARCH REPORT

Information on patent family members

International Application No.

PCT, SE 96/00814

Patent document cited in search report	Publication date	Patent family member(s)	Publication date
WO-A-9510144	13-04-95	SE-C- 503548 EP-A- 0721705 SE-A- 9303213	01-07-96 17-07-96 02-04-95
US-A-5295138	15-03-94	NONE	
US-A-5400322	21-03-95	NONE	
EP-A-0637181	01-02-95	DE-A- 4325190 FI-A- 943525	02-02-95 28-01-95
EP-A-0490509	17-06-92	CA-A- 2032325 US-A- 5239676	15-06-92 24-08-93

Form PCT/ISA/21B (patent family annex) (July 1992)



---

フロントページの続き

(81)指定国 EP(AT, BE, CH, DE, DK, ES, FI, FR, GB, GR, IE, IT, LU, MC, NL, PT, SE), OA(BF, BJ, CF, CG, CI, CM, GA, GN, ML, MR, NE, SN, TD, TG), AP(KE, LS, MW, SD, SZ, UG), UA(AM, AZ, BY, KG, KZ, MD, RU, TJ, TM), AL, AM, AT, AU, AZ, BB, BG, BR, BY, CA, CH, CN, CZ, DE, DK, EE, ES, FI, GB, GE, HU, IL, IS, JP, KE, KG, KP, KR, KZ, LK, LR, LS, LT, LU, LV, MD, MG, MK, MN, MW, MX, NO, NZ, PL, PT, RO, RU, SD, SE, SG, SI, SK, TJ, TM, TR, TT, UA, UG, UZ, VN



INTERNATIONAL APPLICATION PUBLISHED UNDER THE PATENT COOPERATION TREATY (PCT)

<p>(51) International Patent Classification 7 : <b>H04M 3/00</b></p>	<p><b>A2</b></p>	<p>(11) International Publication Number: <b>WO 00/64130</b> (43) International Publication Date: 26 October 2000 (26.10.00)</p>
<p>(21) International Application Number: PCT/US00/10301 (22) International Filing Date: 17 April 2000 (17.04.00) (30) Priority Data: 09/294,563 20 April 1999 (20.04.99) US (71) Applicant: TERADYNE, INC. [US/US]; 321 Harrison Avenue, Boston, MA 02118 (US). (72) Inventors: RUDINSKI, Iliia, L.; 1717 W. Crystal Lane, Mount Prospect, IL 60056 (US). SCHMIDT, Kurt, E.; 6444 W. Brever Road, Burlington, WI 53105 (US). (74) Agent: WALSH, Edmund, J.; Teradyne, Inc., 321 Harrison Avenue, Boston, MA 02118 (US).</p>	<p>(81) Designated States: AE, AG, AL, AM, AT, AU, AZ, BA, BB, BG, BR, BY, CA, CH, CN, CR, CU, CZ, DE, DK, DM, DZ, EE, ES, FI, GB, GD, GE, GH, GM, HR, HU, ID, IL, IN, IS, JP, KE, KG, KP, KR, KZ, LC, LK, LR, LS, LT, LU, LV, MA, MD, MG, MK, MN, MW, MX, NO, NZ, PL, PT, RO, RU, SD, SE, SG, SI, SK, SL, TJ, TM, TR, TT, TZ, UA, UG, UZ, VN, YU, ZA, ZW, ARIPO patent (GH, GM, KE, LS, MW, SD, SL, SZ, TZ, UG, ZW), Eurasian patent (AM, AZ, BY, KG, KZ, MD, RU, TJ, TM), European patent (AT, BE, CH, CY, DE, DK, ES, FI, FR, GB, GR, IE, IT, LU, MC, NL, PT, SE), OAPI patent (BF, BJ, CF, CG, CI, CM, GA, GN, GW, ML, MR, NE, SN, TD, TG).</p> <p><b>Published</b> <i>Without international search report and to be republished upon receipt of that report.</i></p>	

(54) Title: DETERMINING THE PHYSICAL STRUCTURE OF SUBSCRIBER LINES

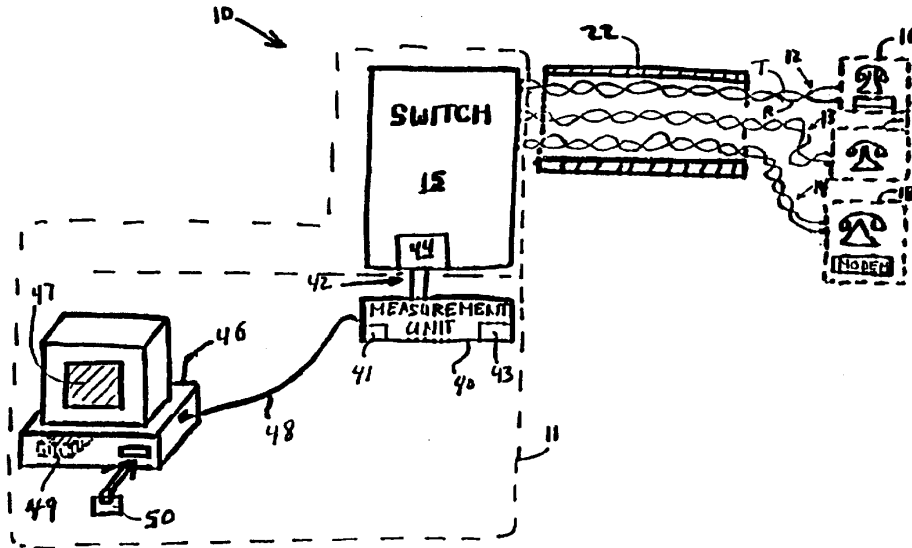

(57) Abstract

A method determines a structure of a subscriber line. The method includes searching a reference set for a match between the subscriber line and a model line of the reference set and identifying that the subscriber line has a specific physical structure. The match is based on electrical properties of the lines. The act of identifying is responsive to finding a match with one of the model lines that has the specific physical structure.

**FOR THE PURPOSES OF INFORMATION ONLY**

Codes used to identify States party to the PCT on the front pages of pamphlets publishing international applications under the PCT.

AL	Albania	ES	Spain	LS	Lesotho	SI	Slovenia
AM	Armenia	FI	Finland	LT	Lithuania	SK	Slovakia
AT	Austria	FR	France	LU	Luxembourg	SN	Senegal
AU	Australia	GA	Gabon	LV	Larvia	SZ	Swaziland
AZ	Azerbaijan	GB	United Kingdom	MC	Monaco	TD	Chad
BA	Bosnia and Herzegovina	GE	Georgia	MD	Republic of Moldova	TG	Togo
BB	Barbados	GH	Ghana	MG	Madagascar	TJ	Tajikistan
BE	Belgium	GN	Guinea	MK	The former Yugoslav Republic of Macedonia	TM	Turkmenistan
BF	Burkina Faso	GR	Greece	ML	Mali	TR	Turkey
BG	Bulgaria	HU	Hungary	MN	Mongolia	TT	Trinidad and Tobago
BJ	Benin	IE	Ireland	MR	Mauritania	UA	Ukraine
BR	Brazil	IL	Israel	MW	Malawi	UG	Uganda
BY	Belarus	IS	Iceland	MX	Mexico	US	United States of America
CA	Canada	IT	Italy	NE	Niger	UZ	Uzbekistan
CF	Central African Republic	JP	Japan	NL	Netherlands	VN	Viet Nam
CG	Congo	KE	Kenya	NO	Norway	YU	Yugoslavia
CH	Switzerland	KG	Kyrgyzstan	NZ	New Zealand	ZW	Zimbabwe
CI	Côte d'Ivoire	KP	Democratic People's Republic of Korea	PL	Poland		
CM	Cameroon	KR	Republic of Korea	PT	Portugal		
CN	China	KZ	Kazakstan	RO	Romania		
CU	Cuba	LC	Saint Lucia	RU	Russian Federation		
CZ	Czech Republic	LI	Liechtenstein	SD	Sudan		
DE	Germany	LK	Sri Lanka	SE	Sweden		
DK	Denmark	LR	Liberia	SG	Singapore		
EE	Estonia						

DETERMINING THE PHYSICAL STRUCTURE OF SUBSCRIBER LINES

This is a continuation-in-part of Application No.  
U.S. Application No. 09/294,563, filed April 20, 1999.

5

Background of the Invention

This application relates generally to communications networks, and more particularly, to determining electrical properties of multi-wire communication lines.

10 Recently, there has been an increased demand for the subscriber lines of plain old telephone services (POTS's) to carry high-speed digital signals. The demand has been stimulated by home access to both the Internet and distant office computers. Both types of access typically employ a  
15 POTS line as part of the path for carrying digital signals.

POTS's lines were built to carry voice signals at audible frequencies and can also carry digital signals as tone signals in the near audible frequency range. Modern  
20 digital services such as ISDN and ADSL transmit data at frequencies well above the audible range. At these higher frequencies, POTS's lines that transmit voice signals well may transmit digital signals poorly. Nevertheless, many telephone operating companies (TELCO's) would like to  
25 offer ISDN and/or ADSL data services to their subscribers.

Telephone lines between a TELCO switch and subscribers' premises are frequent sources of poor performance at the high frequencies characteristic of ISDN and ADSL transmissions. Nevertheless, high cost has made  
30 widespread replacement of these subscriber lines an undesirable solution for providing subscribers with lines capable of supporting ISDN and ADSL. A less expensive

alternative would be to repair or remove only those subscriber lines that are inadequate for transmitting high-speed digital data.

To limit replacement or repair to inadequate lines, 5 TELCO's have placed some emphasis on developing methods for predicting which subscriber lines will support data services, such as ISDN and ADSL. Some emphasis has been also placed on predicting frequency ranges at which such data services will be supported. Some methods have also 10 been developed for finding faults in subscriber lines already supporting data services so that such faults can be repaired.

Current methods for predicting the ability of subscriber lines to support high-speed digital 15 transmissions are typically not automated, labor intensive, and entail test access at multiple points. Often, these methods entail using skilled interpretations of high frequency measurements of line parameters to determine data transmission abilities. At a network 20 scale, such tests are very expensive to implement.

The present invention is directed to overcoming or, at least, reducing the affects of one or more of the problems set forth above.

25

#### Summary of the Invention

In a first aspect, the invention provides a method of determining a physical structure of a subscriber line. The method includes searching a reference set for a match between the subscriber line and a model line of the reference set and identifying that the subscriber line has 30 a specific physical structure. The match is based on electrical properties of the lines. The act of identifying is responsive to finding a match with one of

the model lines that has the specific physical structure.

In a second aspect, the invention provides a method of qualifying a subscriber line for a data service. The method includes searching a reference set of model lines  
5 for a best match to a subscriber line by comparing sets of electrical properties and determining that the subscriber line has a specific physical structure. The act of determining is responsive to the best matching model line having the specific physical structure. The  
10 method also includes disqualifying the subscriber line for the data service, in part, in response to determining that the specific physical structure corresponds to a disqualified line.

In a third aspect, the invention provides a method  
15 of providing a data service. The method includes searching for a match between electrical properties of a subscriber line and a model line of a reference set and determining whether the subscriber's line is qualified for the data service. The act of determining is based in  
20 part on whether the best matching model line has one of a bridged tap and a mixture of gauges. The method also includes performing a business action in response to determining that the subscriber's line is qualified.

In a fourth aspect, the invention provides a data  
25 storage device that stores an executable program of instructions for causing a computer to perform one or more of the above-described methods.

Various embodiments use test accesses, which provide  
30 data on low frequency electrical properties of subscriber lines, to make predictions about high frequency performance.

Brief Description of the Drawings

Other features and advantages of the invention will be apparent from the following description taken together with the drawings in which:

5       FIG. 1 shows a portion of a POTS network having a system for detecting faults in subscriber telephone lines;

      FIG. 2A shows a first measuring setup for making one-ended electrical measurements on a subscriber telephone line;

10       FIG. 2B is an equivalent circuit for the measuring setup of FIG. 2A;

      FIG. 2C shows a second measuring setup for making one-ended electrical measurements on a subscriber telephone line;

15       FIG. 3 illustrates signal distortions produced by the test bus and standard voice test access;

      FIG. 4 shows a split pair fault in a subscriber line;

      FIG. 5 shows how a splice error can produce a split pair fault;

20       FIG. 6A shows a phase measurement signature of a resistive imbalance on a subscriber line;

      FIG. 6B shows a phase measurement signature of a split pair fault on a subscriber line;

25       FIG. 7 is a flow chart illustrating a method of detecting faults on subscriber lines with the system of FIGs. 1, 4, and 5;

      FIG. 8 is a flow chart illustrating a method of qualifying subscriber lines with the method of FIG. 7;

30       FIG. 9 shows a method of providing high speed data services using the methods of FIGs. 7 and 8;

      FIG. 10A-10E show exemplary subscriber lines having different gauge mixes;

      FIG. 11 shows a subscriber line with a bridged tap;

FIG. 12A-12E shows exemplary structures of subscriber lines having one bridged tap;

FIG. 13 is a flow chart for a method of determining the specific physical structure of a subscriber line from a reference set;

FIG. 14 is a flow chart for a method of finding a best match between a subscriber and model lines;

FIG. 15 is a flow chart for a method of qualifying subscriber lines; and

FIG. 16 is a flow chart for a business method of providing high-speed data services to subscribers.

FIG. 17 is a flow chart for a stacked method of detecting bridged taps using auxiliary variables;

FIG. 18A shows predicted and actual signal attenuations of nominal subscriber lines;

FIG. 18B shows predicted and actual signal attenuations of non-nominal subscriber lines;

FIG. 18C shows predicted, shifted predicted, and actual signal attenuations for an exemplary nominal subscriber line;

FIG. 19 shows an exemplary decision tree;

FIG. 20 illustrates the action of the rules of the decision tree of FIG. 19 on a set of subscriber lines;

FIG. 21 is a flow chart illustrating a method of creating the decision trees with machine learning methods; and

FIG. 22 is a flow chart for a method of determining the branching rules of the decision tree illustrated in FIGs. 19-20.

#### Description of the Preferred Embodiments

##### MEASUREMENT AND TEST APPARATUS

FIG. 1 shows a portion of a POTS network 10 that has a system 11 for detecting faults in subscriber lines 12-



14. The subscriber lines 12-14 connect subscriber units 16-18, i.e., modems and/or telephones, to a telephony switch 15. The switch 15 connects the subscriber lines 12-14 to the remainder of the telephone network 10. The  
5 switch 15 may be a POTS switch or another device, e.g., a digital subscriber loop access multiplexer (DSLAM).

Each subscriber line 12-14 consists of a standard twisted two-wire telephone line adapted to voice transmissions. The two wires are generally referred to as  
10 the ring AR@ and tip AT@ wires.

A large portion of each subscriber line 12-14 is housed in one or more standard telephone cables 22. The cable 22 carries many subscriber lines 12-14, e.g., more than a dozen, in a closely packed configuration. The  
15 close packing creates an electrical environment that changes transmission properties of the individual subscriber lines 12-14.

Electrical measurements for detecting line faults are performed by a measurement unit 40. In various  
20 embodiments, the measurement unit 40 includes one or both devices 41 and 43. Each device 41, 43 performs one-ended electrical measurements on selected lines 12-14. In preferred embodiments, the electrical measurements are one-ended. The device 41 performs measurements on tip and  
25 ring wires of a selected subscriber line 12-14 in a common mode configuration and produces results useful for detecting split pairs. The device 43 can measure admittances of the tip and ring wires of a selected line 12-14 either separately or together and produces data  
30 useful for determining the specific physical line structure. The measurement unit 40 may also house other devices (not shown) for performing other types of electrical measurements, i.e., one-ended or two-ended measurements. The measurement unit 40 couples to the

switch 15 via a test bus 42.

The devices 41, 43 connect to the switch 15 through the test bus 42 and a standard voice test access 44. The voice test access 44 electrically connects either the  
5 device 41 or device 43 to the subscriber lines 12-14 selected for testing. The voice test access 44 generally transmits electrical signals with low frequencies between about 100 Hertz (Hz) and 20 kilo Hz (KHz). But, the test  
10 access 44 may transmit signals at higher frequencies, e.g., up to 100 to 300 KHz, in some switches 15.

The measurement unit 40 is controlled by computer 46, which selects the types of measurements performed, the device 41, 43 used, and the subscriber lines 12-14 to test. The computer 46 sends control signals to the  
15 measurement unit 40 via a connection 48, e.g., a line, network, or dedicated wire, and receives measurement results from the measurement unit 40 via the same connection 48.

The computer 46 contains a software program for  
20 controlling line testing by the measurement unit 40 and for detecting line conditions or faults with results from the measurement unit 40. The software program is stored, in executable form, in a data storage device 49, e.g., a hard drive or random access memory (RAM). The program may  
25 also be encoded on a readable storage medium 50, such as an optical or magnetic disk, from which the program can be executed.

To perform a test, the measurement unit 40 signals the voice test access 44 to connect the line 12-14 to be  
30 tested to wires of the bus 42 for connecting to internal devices 41, 43. Then, one or both of the internal devices 41, 43 performs electrical measurements on the selected line 12-14. After the measurements are completed, the measurement unit 40 signals the switch 15 to disconnect

the line 12-14 from the wires of the bus 42.

The computer 46 can classify selected subscriber lines 12-14 prior to fully connecting the lines 12-14 for data services. The range of possible classes to which a line 12-14 can be assigned will depend on the business  
5 needs of a TELCO. A simple, but very useful set of classes is "qualified" and "disqualified" to provide data services. Qualification is based on determining, with high certainty, that a selected line 12-14 will support a  
10 specified data service. Disqualification is based on determining, with high certainty, that the selected line 12-14 will not support the specified data service.

FIG. 2A shows a first setup 52 for performing one type of one-ended electrical measurements with the device  
15 41. The measurements are used to detect faults such as split pairs in the subscriber lines 12-14 of FIG. 1.

The device 41 has a variable frequency voltage source 54 for driving the tip and ring wires T, R of the subscriber line 12-14 under test. The voltage source  
20 drives both wires together, i.e., in a common mode configuration, at a frequency controlled by the measurement unit 40. The tip and ring wires T, R of the line 12-14 under test are connected to the device 41 via the voice test access 44.

The voltage source 54 connects to one side of resistors  $R_1$  and  $R_2$ . The second side of resistors  $R_1$  and  $R_2$   
25 connect to the respective tip and ring wires T, R of the subscriber line 12-14 under test. Thus, the voltage source 54 drives the tip and ring wires T, R in common mode through the corresponding resistors  $R_1$  and  $R_2$ .  
30

The resistors  $R_1$  and  $R_2$  have equal resistances so that the voltage source 54 induces equal voltages  $V_1$ ,  $V_2$  between each resistor  $R_1$ ,  $R_2$  and ground if the currents  $I_T$ ,  $I_R$  therein are also equal. Differences in the input

impedances  $Z_T$ ,  $Z_R$  of the tip and ring wires T, R make the voltages  $V_1$ ,  $V_2$  differ in amplitude and/or phase. For example, mutual inductance effects produced by a split pair can make the input impedances  $Z_T$ ,  $Z_R$  unequal.

5        Voltmeters  $VM_1$  and  $VM_2$  measure amplitudes and phases of voltages  $V_1$  and  $V_2$ , respectively. From measurements of the voltmeters  $VM_1$  and  $VM_2$ , the computer 46 can obtain the phase difference between  $V_1$  and  $V_2$ .

FIG. 2B shows an equivalent circuit 55 for the  
10 measurement setup 52 of FIG. 4. In the common mode configuration, the tip and ring wires T, R act as elements of independent circuits 56, 57 that connect the voltage source 54 to a common ground 58. The tip wire T is equivalent to an impedance  $Z_T$  in the circuit 56, and the  
15 ring wire R is equivalent to an impedance  $Z_R$  in the circuit 57.

The input impedances  $Z_T$  and  $Z_R$  may have different amplitudes and/or phases due to the presence of a fault on either the tip or ring wires T, R. Different values for  $Z_T$   
20 and  $Z_R$  produce different currents  $I_T$  and  $I_R$  in the circuits 56 and 57 and different measured voltages  $V_1$  and  $V_2$ . The phase of the voltage difference  $V_1 - V_2$  is proportional to the phase difference between the input impedances of the tip and ring wires T, R. In the phase of the difference  $V_1$   
25 -  $V_2$ , termination effects associated with the attached subscriber unit 16 can largely be ignored.

FIG. 2C shows a measuring setup 60 for performing one-ended electrical measurements on a selected subscriber line 12-14 with the device 43 shown in FIG 1. The device  
30 43 measures electrical properties, which can be used to determine the specific physical structure of the lines 12-14 and to determine line conditions and faults as is described below. Some methods for detecting line faults and conditions with the device 43 have been described in

U.S. Application No. 09/294,563 ('563), filed April 20, 1999. The '563 application is incorporated herein, by reference, in its entirety.

The device 43 is adapted to measure admittances  
 5 between the tip wire T, ring wire R, and ground G for a  
 subscriber line 12-14 being tested. The tip and ring  
 wires T, R of the line 12-14 being tested couple to  
 driving voltages  $V_1'$  and  $V_2'$  through known conductances  $G_t$   
 and  $G_r$ . The tip and ring wires T, R also connect to  
 10 voltmeters  $V_t$  and  $V_r$ . The  $V_t$  and  $V_r$  voltmeters read the  
 voltage between the tip wire T and ground G and between  
 the ring wire R and ground G, respectively. The readings  
 from the voltmeters  $V_t$  and  $V_r$  enable the computer 46 to  
 determine three admittances  $Y_{tg}$ ,  $Y_{tr}$ , and  $Y_{rg}$  between the  
 15 pairs tip-ground, tip-ring, and ring-ground, respectively.

The device 43 can measure the admittances at preselected  
 frequencies in the range supported by the voice test  
 access 44. The '563 application has described methods for  
 performing such measurements.

20 Referring to FIG. 3, the computer 46 may compensate  
 for signal distortions introduced by the test bus 42  
 and/or the voice test access 44. To perform compensation,  
 the computer 46 treats the two lines of the combined bus  
 42 and test access 44 as a linear two port systems. Then,  
 25 the currents and voltages  $I_T'$ ,  $V_T'$  and  $I_R'$ ,  $V_R'$  at the  
 output terminals of the measurement device 40 are related  
 to the currents and voltages  $I_T$ ,  $V_T$  and  $I_R$ ,  $V_R$  on the output  
 terminals of the tip and ring wires T, R by the following  
 2x2 matrix equations:

$$30 \quad [I_T, V_T] = A(f) [I_T', V_T']^t \text{ and } [I_R, V_R] = A'(f) [I_R', V_R']^t.$$

The frequency dependent matrices  $A(f)$  and  $A'(f)$  are  
 determined experimentally for each bus 42 and voice test  
 access 44. Then, the computer 46 calculates the  
 impedances or admittances of the tip and ring wires T, R

with the currents and voltages  $I_T$ ,  $V_T$  and  $I_R$ ,  $V_R$  obtained from the above equations.

The measurement unit 40 and computer 46 can detect faults such as split pairs, resistive imbalances, metallic  
5 faults, load coils, bridged taps, gauge mixtures, and high signal attenuations. Co-pending U.S. Patent Application 09/285,954 ('954), filed April 2, 1999, describes the detection of some of these faults and is incorporated herein by reference in its entirety.

10

#### SPLIT PAIRS

Referring again to FIG. 1, close proximity can inductively produce cross talk between the subscriber lines 12-14. Cross talk is frequently caused by large  
15 noise or ringing signals on one of the lines 12-14. The large signal inductively produces signals on nearby lines 12-14. To reduce cross talk, the tip and ring wires T, R of each subscriber line 12-14 are either tightly twisted together or kept in close proximity in the cable 22. In  
20 this way, stray signals affect both wires of a pair so that induced signals do not impact the difference signal between the tip and ring wires.

Referring to FIG. 4, the tip and ring wires T', R' of a subscriber line 24 are separated spatially in a portion  
25 of cable 26. The portion of the subscriber line 24 in which the tip and ring wires T', R' are spatially separated is referred to as a split pair. A split pair T', R' has a high risk of picking up cross talk other lines 28-29 in the same cable 26 or external noise sources  
30 such as power lines (not shown).

Split pairs also introduce impedance discontinuities into subscriber lines, because the split pair creates a localized and abrupt impedance variation. Impedance discontinuities can cause signal reflections and high

signal attenuations for high-speed digital transmissions.

FIG. 5 illustrates one type of split pair, i.e., a split pair caused by a splice error. The splice error occurred when two portions of a subscriber line 32, which are located in two different cables 33, 34, were joined. The splice 35 has joined tip and ring wires  $T_1$ ,  $R_2$  from two different twisted pair lines 36, 37 in the cable 33 to tip and ring wires  $T_3$ ,  $R_3$  of a single twisted pair 38 in the adjacent cable 34. The tip and ring wires  $T_1$ ,  $R_2$  of the portion of the subscriber line 32 are widely separated in a substantial portion of the cable 33. Thus, the tip and ring wires  $T_1$ ,  $R_2$  form a split pair.

Detection of split pair faults is difficult for several reasons. First, split pairs do not produce easily detected effects such as metallic faults, i.e., broken wires or shorted wires, or impedance imbalances. Second, split pairs produce cross talk that produce intermittent faults depending on the signals on nearby lines, e.g., intermittent ringing signals. The intermittency makes such faults difficult to recognize.

Conventional tests have not been very successful in detecting split pairs. Nevertheless, split pairs can degrade the quality of a subscriber line for high-speed data services.

FIG. 6A and 6B provide graphs 68, 69 of the phase of the voltage difference  $V_1 - V_2$  between resistors  $R_1$  and  $R_2$  while testing two exemplary subscriber lines 12-14 with the measurement setup 52 of FIG. 4. The graphs 68, 69 provide frequency sweeps of the phase difference, which show signatures of faults that can interfere with high-speed data services, e.g., ISDN or ADSL.

Referring to FIG. 6A, the graph 68 shows a signature for a resistive imbalance fault on the tested subscriber line 12-14. The signature for a resistive imbalance is a

pronounced peak in the phase of the voltage difference  $V_1 - V_2$ . The peak appears in the phase difference between impedances of the tip and ring wires. The peak has a narrow width that is typically not more than a few hundred  
5 to about 2 KHz. Typically, the phase has a height of greater than about  $5^\circ$ .

Referring to FIG. 6B, the graph 69 shows a signature for a split pair fault on the tested subscriber line 12-14. The signature is a flat and substantially constant  
10 phase for  $V_1 - V_2$ , i.e., a substantially constant non-zero phase difference between the input impedances  $Z_T$ ,  $Z_R$  of the wires T, R. Typically, the phase has a value of between about  $.5^\circ$  and  $1.5^\circ$ . The nonzero and flat phase extends  
15 over a region of frequencies having a width of at least 5,000 kilo Hz. The phase of  $Z_T$  and  $Z_R$  may remain flat, nonzero, and peakless from about 100 Hz to about 20,000 Hz if a split pair is present, i.e., over the frequency range measurable through the voice test access 44; shown in FIG.  
20 1. A nonzero and substantially frequency independent phase difference between the input impedances  $Z_T$ ,  $Z_R$  of the tip and ring wires is a signature for a split pair on the subscriber line 12-14 being tested.

FIG. 7 is a flow chart illustrating a method 70 of  
25 detecting a fault in the subscriber lines 12-14 with the system 11 of FIG. 1. The computer 46 selects the subscriber line 12-14 to test for faults (step 72). The measurement unit 40 electrically connects to the selected line 12-14 via the voice test access 44 of the TELCO switch 15 (step 74). The connection produces the  
30 measurement setup 52 illustrated in FIGs. 4 and 5.

The measurement unit 40 performs one-ended electrical measurements to determine a signal proportional to the phase difference of the input impedances  $Z_T$ ,  $Z_R$  of the tip



and ring wires of the selected line 12-14 (step 76). The quantity actually measured is the phase of  $V_1 - V_2$ , which is proportional to the phase of the difference of the input impedances  $Z_T, Z_R$ . The device 41 measures the phase  
5 by driving the tip and ring wires in the common mode configuration shown in FIG. 4. The driving frequencies are between about 100 Hz to 20,000 kilo Hz and accessible via the voice test access 44. Such frequencies are very low compared to transmission frequencies of high-speed  
10 data services such as ISDN and ADSL.

The computer 46 analyzes the measurements of the phase as a function of frequency to determine whether the phase has a signature for a line fault (step 78). The line faults that produce signatures in the phase include  
15 split pairs and resistance imbalances as described above in relation to FIGs. 6B and 6A, respectively. Other signatures are possible, e.g., for other types of faults.

If a signature for a line fault is found, the computer 46 identifies that a fault has been detected (step 80). The  
20 identification may entail making a reporting act. The reporting act may include making an entry in a file that lists the faults on the subscriber lines 12-14, displaying a warning on an operator's display screen 47 or on a screen of a service technician (not show), or informing a  
25 program that allocates subscriber lines 12-14. If no signatures for line faults are found, the computer 46 identifies the absence of the line faults associated with signatures for the selected line 12-14, e.g., by performing a reporting act (step 82).

30 FIG. 8 is a flow chart illustrating a method 90 for a test that determines whether the subscriber lines 12-14 of FIG. 1 qualify or disqualify for a high-speed data service. To start a test, an operator or the computer 46 selects a subscriber line 12-14 (step 92). The operator

or computer 46 also selects the type of data service for which the selected subscriber line 12-14 is to be tested (step 94). For example, the types of service may be ISDN or ADSL. After selecting the line 12-14 and service type, 5 the measurement unit 40 performs one-ended electrical measurements to detect preselected types of faults in the selected line 12-14 (step 96). The one-ended measurements include tests according to the method 70 of FIG. 7 to detect split pairs.

10 The other types of line faults and conditions, which are selected for testing, depend on the types and speeds of data services, the properties of the switch 15, and the type of modem to be used. Frequently, tests check for high signal attenuations, resistive imbalances, and the 15 presence of load coils, metallic faults, or bridged taps, because these conditions and faults can disqualify a line for high-speed data service. But, line qualification tests may also check for capacitive imbalances, and above-threshold noise levels, because these conditions can also 20 affect qualification results. Methods and apparatus for detecting some of these conditions and faults are described in co-pending patent applications.

One such application is U.K. Patent Application No. 9914702.7, titled "Qualifying Telephone Lines for Data 25 Transmission", by Roger Faulkner, filed June 23, 1999, which is incorporated herein by reference, in its entirety. Other such co-pending applications include the above-mentioned '954 and '563 patent applications.

30 If one of the preselected types of faults or line conditions is detected, the computer 46 reports that the selected subscriber line 12-14 is disqualified for the selected data transmissions (step 98). Otherwise, the computer 46 reports that the selected line 12-14 qualifies for the selected data service (step 100).

To report the tested line's status, the computer 46 makes an entry in a list stored in the storage device 49.

The list identifies the line, data service, and qualification or disqualification status. The computer 46  
5 may also report the line's status by displaying a disqualification or qualification signal on the display screen 47 visible to an operator.

FIG. 9 is a flow chart for a method 101 used by a TELCO to provide a high-speed data service, e.g., ISDN or  
10 ADSL, to telephone subscribers. The TELCO programs the computer 46 of FIG. 1 to automatically select individual subscriber lines 12-14 connected to the local switch 15 (step 102). In response to selecting the line 12-14, the voice test access 44 connects the selected line 12-14 to  
15 the measurement unit 40 for testing (step 104). The measurement unit 40 connects the selected line 12-14 to the measurement device 41 and may also connect the selected line 12-14 to other internal measurement devices (not shown). The computer 46 and measurement unit 40  
20 determine whether the selected line 12-14 has a split pair and qualifies for the data service according to the methods 70, 90 of FIGs. 7 and 8 (step 106). Next, the computer 46 updates a list recording the identities of lines 12-14 that qualify and of lines 12-14 having split  
25 pairs (step 108). The computer 46 waits a preselected time and restarts the testing for another of the lines 12-14 at step 102.

The TELCO regularly checks the list to determine whether any of the lines 12-14 have split pairs (step  
30 110). If a line has a split pair, the TELCO performs a business action based on the presence of the split pair fault (step 112). The business action may include sending a worker to repair or replace the affected line 12-14, designating the affected line 12-14 as unable to transmit

data, or setting a lower billing rate based on the presence of the fault.

The TELCO also regularly checks the list to determine whether any of the lines 12-14 qualify for the high-speed data service (step 114). In response to finding that one  
5 or more of the lines 12-14 qualify, the TELCO performs a business action related to the line's qualification (step 116). For example, the TELCO may offer the high speed data service to subscribers who have the lines 12-14  
10 qualified for the data service and who do not presently subscribe to the data service.

#### SPECIFIC PHYSICAL STRUCTURE OF SUBSCRIBER LINES

Referring again to FIG. 1, the subscriber lines 12-14  
15 may have widely different physical structures. A line's specific physical structure is described by properties such as line length, gauge or gauges, and content of bridge taps. Interpretations of electrical measurements to obtain line transmission properties such as the signal  
20 attenuation are dependent upon the specific physical line structure. Thus, knowing the specific physical structure of a subscriber line aids in predicting how well the line 12-14 will support high speed digital data services, e.g., to predict maximum data speeds.

FIGs. 10A-E illustrate parameters that describe gauge mix parameters through exemplary lines 121-125 in which drawing widths represent wire gauges. The lines 121, 122 have uniform structures described by different wire gauges. The lines 124, 125 have segmented structures in  
30 which adjacent segments have different wire gauges, i.e., mixtures of gauges. The gauge composition of these lines 124, 125 is described by segment lengths and segment gauges. The structures are also described by the serial layout of the segments. The line 123 has different tip

and ring wires  $T_4$ ,  $R_4$  and is described by the gauges of the  $T_4$  and  $R_4$  wires.

Referring now to FIG. 11, a subscriber line 127 has an extra twisted wire pair 128 spliced onto the line 127.

5 The spliced on wire pair 128 is referred to as a bridged tap. The existence or absence of bridged taps is a parameter that also influences how well the subscriber line 127 will support high-speed digital data services.

10 In the United States, many subscriber lines have bridged taps because of the way in which telephone lines were laid out in housing subdivisions. Telephone lines were laid out prior to determining the exact positioning of the houses of the subdivisions. The lines ran near planned positions of several houses. When the houses were  
15 later built, the builder connected the telephone units to the nearest point on one of the originally laid telephone lines. Unconnected portions of the original lines produced bridged taps.

The bridged tap 128 reflects signals from termination  
20 129. The reflected signals then travel back to the subscriber line 127 and interfere with signals on the subscriber line 127. The most harmful interference occurs when the reflected signal is out of phase with the incoming signal. In such a case, the reflected signal  
25 destructively interferes with the incoming signal on the subscriber line 127.

The length of the bridged tap 128 determines the phase difference between the original and reflected signals. For high-speed digital signals whose frequencies  
30 extend to about 1 mega Hertz (MHz), e.g., ADSL signals, a substantial cancellation can occur if the bridged tap 128 has a length between about 200 to 700 feet. In the United States, the bridged taps left over from the construction of many housing subdivisions have lengths in this range.

Thus, the ability to detect and remove the bridged tap 128 is useful to TELCO's that want to offer high-speed digital data services to their subscribers.

FIGs. 12A-12E illustrate structure parameters that describe bridged taps 130, 134 through exemplary subscriber lines 135-139. The lines 135, 136 have bridged taps 130, 131 described by different physical lengths. The lines 137-138 have bridged taps 132, 133 described by different locations along the lines 137, 138. The line 139 has a bridged tap 134, which is at least partially described by its location along a particular segment of the line 139. Finally, the lines 136, 139 have bridged taps 131, 134 described by different gauges.

To determine the specific physical structures of unknown subscriber lines, a reference set of model lines may be employed. A reference set is an ensemble of model lines with different and known specific physical structures. To determine the specific physical structure of an unknown subscriber line, measured properties of the unknown line are compared to the same properties in model lines. If a match is found, the unknown line has the same specific physical structure as the matching model line.

Reference data on the specific physical structures of the model lines may be compiled in either a reference data file or a set of reference equations. Both the reference data file and the set of reference equations index the individual model lines by values of a preselected set of measurable electrical properties. In some embodiments, the preselected electrical properties are the frequency-dependent admittances measurable with the device 43 of FIG. 2C.

The content of model lines in the reference set may be tailored to the expected structures of the unknown subscriber lines. For example, if the unknown lines do

not have bridged taps, the reference set might not have model lines with bridged taps. On the other hand, if the unknown lines may have bridged taps, the reference set includes some model lines with bridged taps. Knowledge of  
5 the practices used to lay out the subscriber lines under test can help to determine the best content of model lines for the reference set. For different subscriber line populations, reference sets can be selected empirically or based on human knowledge.

10 Typically, the reference set includes model lines having uniformly varying values of the parameters described in relation to FIGs. 10A-10E and 12A-12E. The model lines have a distribution of lengths and may include one, two, or three segments with zero, one, or two bridged  
15 taps, and a distribution of subscriber termination loads. The segments and bridged taps can have varying lengths, locations, and gauges.

FIG. 13 is a flow chart for a method 140 of determining the specific physical line structure of the  
20 subscriber lines 12-14 of FIG. 1 from a reference set of model lines. To start, an operator or the computer 46 selects a subscriber line (ssl) to test (step 142). The computer 46 directs the measuring unit 40 to perform preselected one-ended electrical measurements on the  
25 selected subscriber line over a range of frequencies (step 144).

In one embodiment, the electrical measurements are one-ended and performed with the device 43, shown in FIG. 2C. During the measurements, the voltage source 54 drives  
30 the tip and/or ring wires of the selected subscriber line 12-14 with voltage sources  $V_1'$ ,  $V_2'$ . The driving frequency is swept over a range, e.g., from about 100 Hertz to about 20,000 to 40,000 Hertz, and one or more of the admittances  $Y_{tg}$ ,  $Y_{tr}$ ,  $Y_{rg}$  are measured for various driving frequencies.

The measurements provide complex input admittances, i.e., amplitudes and phases for a preselected set of frequencies "f".

After performing the measurements, the computer 46  
5 searches for a "best" match between model lines belonging to the reference set and the selected subscriber line (step 146). The search for matches involves comparing preselected electrical properties of the selected subscriber line to the same properties for the model  
10 lines. For the selected subscriber line, the values of the preselected electrical properties are obtained from the one-ended electrical measurements. For the model lines, the values of the same electrical properties are either looked up from a file in the data storage device 49  
15 or calculated from a set of reference equations. The comparison determines which model line "best" matches the selected subscriber line.

The computer 46 identifies a specific physical line structure for the selected subscriber line 12-14 has the  
20 same form as the specific physical line structure of the "best" matching model line (step 148). Identifying the specific physical line structure may include reporting the structure, e.g., displaying values of parameters for the specific physical structure to a operator, writing the  
25 values to a file, or providing the values to a software application. For example, the software application may use the match information to qualify or disqualify the selected line 12-14. The parameters may provide gauge mixtures and tap locations and positions.

30 For the model lines, the specific physical structures are either stored in the same file listing the electrical properties of the model lines or determined from the reference equations. Actual values of the electrical properties and structure parameters of the model lines are



obtained prior to testing the subscriber line by analytic calculations or experimentation.

In a preferred embodiment, the computer 46 finds the "best" matching model line by calculating an error function for each model line (ml). The error function has one of two forms E or E' given by:

$$E = \sum_f W(f) |M_{ml}(f) - M_{ssl}(f)| \quad \text{and} \quad E' = \sum_f W(f) |M_{ml}(f) - M_{ssl}(f)|^{2Q}.$$

$M_{ml}(f)$  and  $M_{ssl}(f)$  are the values of the preselected frequency-dependent electrical properties of the model line (ml) and the selected subscriber line (ssl), respectively.  $Q$  and  $W(f)$  define the form of the error functions, i.e.,  $E$  or  $E'$ .  $Q$  is a fixed integer, e.g., 1 or 2.  $W(f)$  is positive definite weight function, e.g., a function of frequency "f" or a constant.

In some embodiments, the preselected electrical properties  $M_{ml}(f)$ ,  $M_{ssl}(f)$  are the phases of one or more complex admittances of the lines ssl, ml. Various embodiments employ either the phase of the tip-to-ground admittance  $Y_{tg}$ , the phase of the ring-to-ground admittance  $Y_{rg}$ , and/or the phase of the tip-to-ring admittance  $Y_{tr}$ . If the tip-to-ground or ring-to-ground admittances  $Y_{tg}$ ,  $Y_{rg}$  are used, many termination effects due to the subscriber units 16-18 of FIG. 1 are not seen. The phase of these admittances is often small, e.g.,  $4^\circ$  or less, and approximately equals the ratio of the imaginary to real parts of the admittance. For such a case and  $Q = 1$ , the error function  $E'$  is:

$$E' = \sum_f [ \text{Im}(\text{admittance})_{ml} / \text{Re}(\text{admittance})_{ml} - \text{Im}(\text{admittance})_{ssl} / \text{Re}(\text{admittance})_{ssl} ]^2.$$

In another embodiment, the preselected electrical properties  $M_{ml}(f)$ ,  $M_{ssl}(f)$  are the full complex admittances of the lines ssl, ml, i.e.,  $Y_{tg}$ ,  $Y_{rg}$ , and/or  $Y_{tr}$ . Using the

complex admittances themselves can reduce computational times.

Finally, in some embodiments, the best match to the selected subscriber line 12-14 may include a several  
5 different model lines, e.g., model lines generating errors with a below threshold value. In these embodiments, the computer 46 identifies the selected subscriber line 12-14 as having one or more common features of all of the "best  
10 matching" lines. For example, the computer 46 may identify the specific physical structure of the selected subscriber line 12-14 as having a bridged tap if all of the best matching model lines have a bridged tap. Then, the computer 46 may use the presence of a bridged tap in combination with other measurements to qualify or  
15 disqualify the line 12-14.

FIG. 14 illustrates a method 150 of determining  
"best" matches by using the above-described phases. The computer 46 determines the length of the selected  
20 subscriber line using low frequency measurements for line capacitance performed by the measurement unit 40 and device 43 (step 152). Next, the computer 46 selects a model line having the same length as the selected subscriber line (step 154).

The computer 46 restricts comparisons to model lines  
25 with the same length as the subscriber line, because physical line length affects the values of the phases of admittances. Limiting comparisons to this subset of the reference set eliminates false matches with model lines whose lengths differ from the length of the selected  
30 subscriber line.

The computer 46 calculates the error function  $E'$ , based on the phase of preselected admittances, for the selected model line (step 155). The computer 46 checks whether other model lines remain with the same length

(step 156). If other lines remain, the computer 46 repeats the determination of E' for another selected model line (157). If no lines remain, the computer 46 reports the model line having the smallest value for the error function E' as the "best" match to the selected subscriber line (step 158).

Since the reference set may contain as many as 10,000 to 100,000 model lines, the method 150 may search the reference set hierarchically to reduce the total number of searches. In a hierarchical scheme, a first search divides the reference set into non-overlapping groups of model lines. Each group has a large number of lines with similar specific physical structures and defines one model line as a representative of the group. The first search uses the method 150 to determine a "best" match between the selected subscriber line and one of the representative model lines. A second search uses the method 150 on the model lines of the group associated with the best matching representative model line found from the first search.

FIG. 15 is a flow chart illustrating a method 160 of qualifying subscriber lines, e.g., lines 12-14 of FIG. 1, for a high-speed data service, e.g., ISDN or ADSL. After selecting a subscriber line to test, the computer 46 searches a reference set of model lines for a "best" match to the selected subscriber line by using the methods 140, 150 of FIGs. 13 and 14 (step 162). The computer 46 identifies the selected subscriber line as having a bridged tap or mixture of gauges in response to the "best" match model line having a bridged tap or mixture of gauges, respectively (step 163). The computer 46 qualifies or disqualifies the selected subscriber line for the data service, at least in part, based upon whether the subscriber line has a bridged tap or mixture of gauges (step 164).

In some embodiments, the computer 46 uses the signal attenuation to qualify or disqualify the selected subscriber line according to a method described in co-pending U.S. Application No. 08/294,563 ('563). In those  
5       embodiments, the computer 46 calculates the signal attenuation by the methods described in the '563 application. Then, the computer 46 adjusts the calculated value of the signal attenuation up or down depending on a quality factor. The quality factor depends on the  
10       specific physical structure of the line, e.g., upon whether a bridged tap and/or a mixture of gauges is absent or present in the subscriber line.

According to the value of the quality factor, the computer 46 adjusts a calculated signal attenuation up or  
15       down by preselected amounts. For example, the attenuation may be decreased, unchanged, and increased in response to the quality factor being good, average, and poor, respectively. Then, the computer uses the adjusted signal attenuation to determine to qualify or disqualify the  
20       subscriber line for the data service according to methods described in the '563 application.

In other embodiments, the computer 46 uses some specific physical line structures as disqualifiers. For example, if the above-described methods lead to the  
25       detection of a bridged tap, the computer 46 may disqualify the line for the data service.

FIG. 16 is a flow chart illustrating a business method 165, which a TELCO uses to provide a high-speed data service to subscribers. The TELCO determines which  
30       subscriber lines 12-14 of FIG. 1 are qualified and/or disqualified for the data service according to the method 160 of FIG. 15 (step 166).

Using the method 160, the computer 46 determines whether line structures, e.g., bridged taps and/or

selected mixtures of gauges, are present. The specific physical structure is then used to adjust predictions of electrical properties of the subscriber line, e.g., a signal attenuation. If the adjusted values of the electrical properties are outside of thresholds for the data service the line is disqualified.

Among subscribers with qualified lines 12-14, the TELCO determines which subscribers having qualified lines do not subscribe to the data service (step 167). The TELCO offers the data service to subscribers having qualified lines and not presently subscribing to the service (step 168).

In response to finding subscribers with disqualified lines 12-14, the TELCO repairs or replaces those lines 12-14 (step 169).

#### STACKED BRIDGED TAP DETECTION

Referring again to FIG. 1, tests for bridged taps preferably use one-ended electrical measurements that are performed on subscriber lines 12-14 via the "standard" voice test access 44. The voice test access 44 acts as a low pass filter, which screens out frequencies above 20 to 100 KHz. Thus, electrical measurements are generally restricted to low frequencies between about 20 Hz and 100 KHz.

Bridged taps manifest their presence by peaks in the signal attenuation at high frequencies, e.g., between about 200 KHz and 1,000 KHz. Predicting features of the high-frequency signal attenuation from the low-energy measurements, which are available through the voice test access 44, is difficult and error prone. Present methods falsely predict the presence or absence of bridged taps in about 40% of the cases. False predictions are costly to subscribers and TELCO's, because they can result in lost

opportunities for high-speed data services and can also result in investments in transmission equipment that lines do not support.

The accuracy of tests for line conditions and faults, e.g., bridged taps, can be improved with stacked generalization methods that use multiple layers of classifiers. The classifiers determine values of auxiliary variables, which are the labels they assign to classify subscriber lines 12-14. Auxiliary variables are generated as outputs of classifiers. The auxiliary variables are thus, related to electrical measurements on the lines 12-14 indirectly through probabilistic relations embodied in the classifiers. The classifiers of the stack may be decision trees, neural networks, case-based reasoners, or statistically based classifiers. The old electrical properties and new auxiliary variables can be combined in classifiers that provide strong correlations between values of these quantities and the presence or absence of line faults and conditions, such as bridged taps and gauge mixtures.

FIG. 17 is a flow chart illustrating a method 170 for using stacked classifiers to detect selected line conditions or faults from electrical measurements made with the system 11 of FIG. 1. The system 11 preferably performs one-ended electrical measurements on a selected subscriber line 12-14 using either setup 52 or setup 60, shown in FIGs. 2A-2C, 3 (step 172). To these measurements, the computer 46 applies a set of rules that define a preselected set of derived electrical properties for the selected line 12-14 (step 173). Algebraic relations relate the derived properties to the measurements. The measured and derived electrical properties are listed in Appendix A.

The measured and derived properties together form the

input properties for the stack of classifiers. These input properties may include a preliminary value of the signal attenuation, the line length, line impedances, and ratios of line impedances. The selection of the input  
5 line properties for the stack can be changed to accommodate different expected compositions of the subscriber lines 12-14 being tested.

In each layer U, V of classifiers, shown in FIG. 17, the computer 46 determines values of one or more auxiliary  
10 variables for the selected line 12-14. The auxiliary variables may be logic-type variables indicating that the line 12-14 is labeled by a characteristic. The auxiliary variables may also be probability-type variables each indicating the likelihood that the line 12-14 is labeled  
15 by one of a plurality of characteristics.

In the first layer U of the stack, the computer 46 applies a first classifier to input electrical measurements and properties to determine a first auxiliary  
20 variable (step 175). The first auxiliary variable characterizes the line 12-14 with a label "nominal" or a label "non-nominal".

In a nominal line, low frequency properties provide a good prediction of the signal attenuation at the high frequencies where bridged taps strongly affect  
25 attenuation. Thus, knowing a value of an auxiliary variable that labels a line as nominal or non-nominal can improve the accuracy of predictions about the presence of line faults like bridged taps.

Also in the first layer U, the computer 46 applies  
30 one or more second classifiers to the input electrical properties to determine one or more other auxiliary variables (step 176). These auxiliary variables provide a preliminary prediction of whether the selected line 12-14 is qualified or disqualified for one or more high-speed

data services. In some embodiments, values of the auxiliary variables, found at step 176, indicate whether the subscriber line 12-14 is qualified for ISDN or ADSL data services or neither.

5 Disqualification for high-speed data service correlates with presence of a bridged tap, because a bridged tap lowers a line's capability to carry high-frequency signals. Thus, knowing a value of an auxiliary variable that preliminarily labels a line as qualified or  
10 disqualified for data transmissions can improve the accuracy of predictions about the presence or absence of bridged taps.

Steps 175 and 176 may be performed in parallel or sequentially. If these steps 175 and 176 are sequential,  
15 the value of the auxiliary variable output by the earlier step may be used in the later step. If step 175 is earlier, the classifier of step 176 may use the auxiliary variable labeling the line 12-14 as nominal or non-nominal, as an input. If step 176 is earlier, the  
20 classifier of step 175 may use the auxiliary variables providing a preliminary qualification or disqualification for data transmissions as inputs.

At the second layer V of the stack, the computer 46 applies a classifier to the auxiliary variables from steps  
25 175 and 176 and the electrical measurements and properties from steps 172 and 173. This classifier determines whether the selected subscriber line 12-14 has a preselected type of line fault or condition (step 177). For example, the fault or condition may be existence of a  
30 bridged tap or a gauge mixture.

The layered stack U, V can predict the presence or absence of bridged taps with a substantially increased accuracy. The two-layered stack of FIG. 17 can predict the presence of bridged taps with an accuracy of between



about 75% and 85% and the absence of bridged taps with an accuracy of greater than about 97%.

In steps 175, 176, and 177, classifiers analyze input data to determine the values of output data. Henceforth, the input data, which includes one-ended measurements, properties derived from one-ended measurements, and/or auxiliary variables, are referred to as line features. The output data, which are values of auxiliary variables, are referred to as classifying labels.

Their line features and labels can describe the classifiers of steps 175, 176, and 177. The classifier in step 175 uses the selected measured and derived electrical properties of the selected line 12-14 as features to form classes with labels "nominal" and "non-nominal". The classifier of step 176 uses the same features to form classes with labels "ISDN qualified", "ADSL qualified", or "data service disqualified" in one embodiment. The classifier of step 177 uses the same features and values of the characterizing labels from steps 175, 176 to form classes with labels "bridged tap present" and "bridged tap absent".

The label "nominal" describes a type of signal attenuation over a range that includes both low measurement frequencies and high data service frequencies. For a nominal line, the difference between actual and predicted signal attenuations  $AA(f)$  and  $PA(f)$  has a simple dependence on frequency "f". The actual signal attenuation  $AA$  is the attenuation of the line determined from direct double-ended electrical measurements. The predicted signal attenuation  $PA$  is the attenuation obtained from one-ended electrical measurements, e.g., using the system 11 of FIG. 1.

The predicted signal attenuation  $PA(f)$  may be obtained from a subscriber line's capacitance, e.g., the

capacitance  $C_{30\text{Hz}}^{\text{tg}}$  between tip wire and ground measured at 30 Hz. One form for the predicted signal attenuation  $PA(f)$  is:

$$PA(f) = K(f)C_{30\text{Hz}}^{\text{tg}}$$

5 In this formula,  $K(f) = -.1729, -.2074, -.2395, -.2627,$   
and  $-.2881$  dB/nano-Farads for respective frequencies  $f$   
equal to 100, 200, 300, 400, and 500 KHz.

Another form for the predicted attenuation  $PA(f)$  is described in co-pending U.K. Patent Application 9914702.7.

10 For a nominal line, the difference,  $DFF(f)$ , between the actual and the predicted signal attenuations  $AA(f)$ ,  $PA(f)$  has one of the following forms:

- 1)  $DFF(f) < 3.5$  dB for  $100 \text{ KHz} < f < 500 \text{ KHz}$ ;
- 2)  $3.5 \text{ dB} \leq DFF(f) < 10.0$  dB for  $100 \text{ KHz} < f < 500 \text{ KHz}$ ;

15 or

- 3)  $DFF(f) \geq 10.0$  dB for  $100 \text{ KHz} < f < 500 \text{ KHz}$ .

If the frequency dependent difference  $DFF(f)$ , i.e.,  $|AA(f)-PA(f)|$ , does not have form 1, 2, or 3, the line 12-14 is classified as a non-nominal line. Thus, a direct  
20 determination of whether a particular line 12-14 is nominal requires both one-ended and two-ended measurements to obtain both  $PA(f)$  and  $AA(f)$ .

FIG. 18A shows predicted and actual attenuations of exemplary nominal lines A, B, and C. For the line A,  
25 predicted and actual attenuations  $PA_A$  and  $AA_A$  differ by less than 3.5 dB for the entire frequency range between 100 and 500 KHz. The line A has a  $DFF(f)$  of form 1. For the line B, predicted and actual attenuations  $PA_B$ ,  $AA_B$  differ by between 4 and 9 dB over the 100 KHz to 500 KHz  
30 frequency range. The line B has a  $DFF(f)$  of form 2. For the line C, predicted and actual attenuations  $PA_C$ ,  $AA_C$  differ by between more than 10.0 dB over the 100 KHz to 500 KHz frequency range. The line C has a  $DFF(f)$  of form

3.

FIG. 18B shows predicted and actual attenuations of exemplary non-nominal lines D and E. For the line D, predicted and actual signal attenuations  $PA_D$ ,  $AA_D$  differ by about 8 dB at 200 and 400 KHz and are equal at 150 and 300 KHz. This form for  $PA_D$  and  $AA_D$  does not correspond to a  $DFF(f)$  of form 1, 2, or 3. For the line E, predicted and actual signal attenuations  $PA_E$ ,  $AA_E$  differ by less than 3.5 dB at frequencies between 100 and 200 KHz and by more than 8 dB at frequencies between 400 and 500 KHz. This form for  $PA_E$  and  $AA_E$  also does not correspond to a  $DFF(f)$  of form 1, 2, or 3.

In the non-nominal lines D and E wide fluctuations occur in  $DFF(f)$ . These fluctuations make a constant shift of the predicted attenuation  $PA(f)$  a poor approximation to the actual attenuation  $AA(f)$  over the whole range that includes both high and low frequencies.

FIG. 18C shows predicted and actual signal attenuations  $PA_F$ ,  $AA_F$  for another nominal subscriber line F. A shifted predicted attenuation  $SPA_F$ , which has been obtained by shifting the predicted attenuation  $PA_F$  by a constant, is also shown. For the nominal line F, the shifted predicted attenuation  $SPA_F$  provides a better approximation to the actual attenuation  $AA_F$  than the predicted attenuation  $PA_F$  over the entire range between 100 KHz and 500 KHz.

The actual and predicted signal attenuations  $AA(f)$ ,  $PA(f)$  of nominal lines are approximately related by a constant shift over a wide frequency range. The wide frequency range includes both low measurement frequencies and high frequencies where effects of bridged taps are directly observable.

In step 176 of FIG. 17, the labels ISDN qualified, ADSL qualified, and data service disqualified are defined

by the value of the actual signal attenuation at 100 KHz and 300 KHz. High-speed data qualified and disqualified lines satisfy:

Class Label	100 KHz	300 KHz
5 ADSL qualified	attenuation > -47dB	attenuation > -40
ISDN qualified	attenuation > -47dB	attenuation ≤ -40
Disqualified	attenuation ≤ -47dB	attenuation ≤ -40

Thus, qualification or disqualification of a line 12-14 for ADSL and ISDN are defined by the value of the actual signal attenuation at two high frequencies, i.e., 100 KHz and 300 KHz.

FIG. 19 illustrates a decision tree 180 that determines a classifying label, e.g., an auxiliary variable, generated in steps 175-177 of FIG. 17. A separate classifier, e.g., a decision tree, is used to determine each such label.

The decision tree 180 has a hierarchical arrangement of branching tests 1, 1.1-1.2; 1.1.1-2.2.2,..., which are grouped into descending levels 1, 2, 3.... Each test assigns feature data received from a higher level to disjoint subsets in the next lower level. The subsets of the lower level are located at ends of arrows starting at the test. For example, test 1.1 assigns feature data to subsets 1.1 and 1.2, which are located at the ends of arrows 6 and 7, see FIG. 20. At the lower level, another set of tests can act on the feature data.

FIG. 20 illustrates how the tests 1, 1.1, 1.2,... of the various levels of the decision tree 180 of FIG. 19 act on a set of feature data associated with the subscriber lines 12-14. Each successive test partitions the set, i.e., by using values of the selected features, into increasingly disjoint output subsets. For example, test 1

partitions the initial feature data into subset 1 and subset 2. The distal end of each path through the decision tree 180 assigns a subscriber line to a final subset in which the lines are primarily associated with one value of the classifying label of the tree 180. Some  
5 decision trees 180 determine a probability that the subscriber line 12-14 has the value of the label of the final subset to which it is assigned.

FIG. 21 is a flow chart for a method 190 of creating  
10 decision trees for use as the classifiers in steps 175, 176, and 177 of FIG. 17. The method 190 uses machine learning methods.

To employ machine learning, a training set of subscriber line data is created (step 192). The content  
15 the training set includes model lines with different values of the labels used by the decision tree to classify lines. If the decision tree classifies lines with the label "bridged tap present" and "bridged tap absent", then some of the lines of the training sets will have bridged  
20 taps and some of the lines will not have bridged taps. Similarly, in a stack of trees that classifies lines with a particular label, each tree therein is constructed from a training set having lines with different values of the particular label.

25 For each line of the training set, a computer and/or operator determines the values of a set of potential features and the classifying labels (194).

The potential features include one-ended measured and derived electrical properties that may be used in the  
30 tests of the decision tree. The potential electrical properties of one embodiment are listed in Appendix A. The potential features also include values of any auxiliary variables that may be used in the tests of the decision tree. For example, a decision tree used in step

177 of FIG. 17 would also include, as potential features, auxiliary variables determining whether a line is nominal and preliminarily qualified for preselected data services.

5           The classifying labels are the values of the auxiliary variables output by the decision tree. The values of these output auxiliary variables may, for example, include a determination of whether a line is nominal, qualified, or has a bridged tap.

10           Determinations of values of the classifying labels for the lines of the training set may use both one-ended and two-ended electrical measurements. For example, to classify a line of the training set as nominal or non-nominal a two-ended measurement of the actual attenuation and a one-ended measurement of the predicted attenuation  
15           are needed. Similarly, to determine the classifying label associated with qualification for data services, two-ended measurements of the actual attenuation are used. The two-ended measurements are not, however, used as inputs in the  
20           construction of decision trees.

          From the values of the potential features and classifying labels of each line in the training set, the computer 46 recursively determines the branching tests of the decision tree (step 196).

25           FIG. 22 is a flow chart for a method 200 of determining the branching tests of the decision tree 180 shown in FIGs. 19-20. For each potential feature, the computer 46 constructs a test and partitions the training set into groups of disjoint subsets (step 202). The test  
30           associated with a feature assigns each line of the training set to subsets according to a value of that feature for the line.

          The computer 46 evaluates gain ratio criteria for the partitioning of the training set produced by each

potential feature (step 204). The gain ratio criteria measures increases in consistency of line membership for different values of the classification label in each subset. The computer 46 uses the gain ratio criteria to  
 5 find a best test and defines test 1 of the decision tree 180 to be the best test (step 206).

The computer loops back to perform steps 202, 204, and 206 for each subset produced by test 1 to determine the tests of level 2 of the decision tree 180 (loop 208).  
 10 In these determinations, the subsets produced by the best test of level 1 become training sets for finding the tests of level 2. After performing steps 202, 204, and 206 for the subsets 1 and 2, the computer 46 has determined the tests 1.1 and 1.2 of the level 2 (loop 208). The computer  
 15 46 performs loop 208 either until further branches produce line classification errors below a preselected threshold or until no features remain.

Several methods exist for defining the best branching tests at each level of the decision tree 180 of FIG. 19.  
 20 The C4.5 method defines best tests as tests producing the highest values of the gain ratio criteria. The C4.5\* method randomly picks the best tests from the tests whose values of the gain ratio criteria are within a preselected selection percentage of the highest value.

25 The C4.5\* algorithm predicts probabilities that a line with features "d" will be partitioned into each final subset of the decision tree. The probability that the line will be in the majority final subset L is:

$$P_L(d) = 1 - (\sum_{(j \text{ not in } L)} N_j + 1) / (\sum_{(i \text{ in } L)} N_i + 2).$$

30 Here,  $N_i$  is the number of lines in subset "i". The probability that the line will be in a subset "i" is:

$$P_i(d) = [1 - P_L(d)] (N_i / \sum_{(j \text{ in } L)} N_j).$$

In embodiments using the C4.5\* algorithm, the above-

described probabilities are the auxiliary variables used as features in the steps 175-177 of FIG. 17.

Various embodiments combine the methods of detecting line faults (70, 90), determining lines structures (140, 5 160), and stacking fault detection (170), shown in FIGs. 7, 8, 13, 15, 17. By combining the above-mentioned methods, these embodiments can better classify subscriber lines according to a variety of criteria. These criteria include presence of line conditions and faults, line 10 speed, and qualification status.

Other embodiments are within the scope of the following claims.

What is claimed is:



**30Hz Raw Measurements:**

Ytr(30) - Admittance tip-to-ring measured at 30Hz  
 Ytg(30) - Admittance tip-to-ground measured at 30Hz  
 Yrg(30) - Admittance ring-to-ground measured at 30Hz

**30Hz Derived Measurements:**

30Gtr - Conductance tip-to-ring measured at 30Hz = real(Ytr(30))  
 30Str - Susceptance tip-to-ring measured at 30Hz = imag(Ytr(30))  
 30Gtg - Conductance tip-to-ground measured at 30Hz = real(Ytg(30))  
 30Stg - Susceptance tip-to-ground measured at 30Hz = imag(Ytg(30))  
 30Ctr - Capacitance tip-to-ring measured at 30Hz = Str(30)/(2\*pi\*30)  
 30Ctg - Capacitance tip-to-ground measured at 30Hz = Stg(30)/(2\*pi\*30)  
 Lmeas - Length in kft measured at 30Hz = 30Ctg/17.47

**150Hz-20KHz Raw Measurements:**

Ytr(f) - Admittance tip-to-ring where f=150Hz,600Hz,1050Hz,1500Hz,...19950Hz  
 Ytg(f) - Admittance tip-to-ground where f=150Hz,600Hz,1050Hz,1500Hz,...19950Hz  
 Yrg(f) - Admittance ring-to-ground where f=150Hz,600Hz,1050Hz,1500Hz,...19950Hz

**150Hz-20KHz Derived Measurements:**

150Gtr - Conductance tip-to-ring measured at 150Hz = real(Ytr(150))  
 600Gtr - Conductance tip-to-ring measured at 600Hz = real(Ytr(600))  
 .  
 19950Gtr - Conductance tip-to-ring measured at 19950Hz = real(Ytr(19950))  
 150Str - Susceptance tip-to-ring measured at 150Hz = imag(Ytr(150))  
 600Str - Susceptance tip-to-ring measured at 600Hz = imag(Ytr(600))  
 .  
 19950Str - Susceptance tip-to-ring measured at 19950Hz = imag(Ytr(19950))  
 150Gtg - Conductance tip-to-ground measured at 150Hz = real(Ytg(150))  
 600Gtg - Conductance tip-to-ground measured at 600Hz = real(Ytg(600))  
 .  
 19950Gtg - Conductance tip-to-ground measured at 19950Hz = real(Ytg(19950))  
 150Stg - Susceptance tip-to-ground measured at 150Hz = imag(Ytg(150))  
 600Stg - Susceptance tip-to-ground measured at 600Hz = imag(Ytg(600))  
 .  
 19950Stg - Susceptance tip-to-ground measured at 19950Hz = imag(Ytg(19950))  
 150Ctr - Capacitance tip-to-ring measured at 150Hz = 150Str/(2\*pi\*150)  
 600Ctr - Capacitance tip-to-ring measured at 600Hz = 600Str/(2\*pi\*600)  
 .  
 19950Ctr - Capacitance tip-to-ring measured at 19950Hz = 19950Str/(2\*pi\*19950)  
 150Ctg - Capacitance tip-to-ground measured at 150Hz = 150Stg/(2\*pi\*150)  
 600Ctg - Capacitance tip-to-ground measured at 600Hz = 600Stg/(2\*pi\*600)  
 .  
 19950Ctg - Capacitance tip-to-ground measured at 19950Hz = 19950Stg/(2\*pi\*19950)

**150Hz-20KHz Secondary Derived Measurements:**

C30/C4K - Ratio of tip-to-ground Capacitance at 30Hz to 4200Hz  
 C4K/C10K - Ratio of tip-to-ground Capacitance at 4200Hz to 10050Hz  
 Cslope - Tip-to-ground Capacitance ratio slope =  $(C4K/C10K)/(C30/C4K)$   
 C30-C4K - Difference in tip-to-ground Capacitance at 30Hz and 4200Hz  
 C4K-C10K - Difference in tip-to-ground Capacitance at 4200Hz and 10050Hz  
 Cdelta - Tip-to-ground Capacitance difference delta =  $(C4K-C10K)/(C30-C4K)$

G4K/G30 - Ratio of tip-to-ground Conductance at 4200Hz to 30Hz  
 G10K/G4K - Ratio of tip-to-ground Conductance at 10050Hz to 4200Hz  
 Gslope - Tip-to-ground Conductance ratio slope =  $(G10K/G4K)/(G4K/G30)$   
 G4K-G30 - Difference in tip-to-ground Conductance at 30Hz and 4200Hz  
 G10K-G4K - Difference in tip-to-ground Conductance at 4200Hz and 10050Hz  
 Gdelta - Tip-to-ground Conductance difference delta =  $(G10K-G4K)/(G4K-G30)$

C30/G30 - Ratio of Tip-to-ground Capacitance to Conductance at 30Hz  
 C30/G4K - Ratio of Tip-to-ground Capacitance at 30Hz to Conductance at 4200Hz  
 C4K/G4K - Ratio of Tip-to-ground Capacitance to Conductance at 4200Hz

Gtr\_dmax - Maximum positive slope of  $Gtr(f) = \max(\text{derivative}(Gtr(f)/df))$   
 Gtr\_fmax - Frequency at which Gtr\_dmax occurs  
 Gtr\_dmin - Maximum negative slope of  $Gtr(f) = \min(\text{derivative}(Gtr(f)/df))$   
 Gtr\_fmin - Frequency at which Gtr\_dmin occurs  
 Gtr\_fpk - Frequency of first peak (local maxima) in  $Gtr(f)$   
 Gtr\_fval - Frequency of first valley (local minima) in  $Gtr(f)$   
 Gtr\_d\_delta - Gtr Max/Min Derivative difference =  $Gtr\_dmax - Gtr\_dmin$   
 Gtr\_pk\_delta - Gtr peak/valley frequency difference =  $Gtr\_fval - Gtr\_fpk$   
 Gtr\_pk - Value of  $Gtr(f)$  at frequency  $Gtr\_fpk$   
 Gtr\_val - Value of  $Gtr(f)$  at frequency  $Gtr\_fval$   
 Gtr\_delta - Gtr peak/valley difference =  $Gtr\_pk - Gtr\_val$

Gtg\_dmax - Maximum positive slope of  $Gtg(f) = \max(\text{derivative}(Gtg(f)/df))$   
 Gtg\_fmax - Frequency at which Gtg\_dmax occurs  
 Gtg\_dmin - Maximum negative slope of  $Gtg(f) = \min(\text{derivative}(Gtg(f)/df))$   
 Gtg\_fmin - Frequency at which Gtg\_dmin occurs  
 Gtg\_d\_delta - Gtg Max/Min Derivative difference =  $Gtg\_dmax - Gtg\_dmin$

Ctr\_dmax - Maximum positive slope of  $Ctr(f) = \max(\text{derivative}(Ctr(f)/df))$   
 Ctr\_fmax - Frequency at which Ctr\_dmax occurs  
 Ctr\_dmin - Maximum negative slope of  $Ctr(f) = \min(\text{derivative}(Ctr(f)/df))$   
 Ctr\_fmin - Frequency at which Ctr\_dmin occurs  
 Ctr\_fpk - Frequency of first peak (local maxima) in  $Ctr(f)$   
 Ctr\_fval - Frequency of first valley (local minima) in  $Ctr(f)$   
 Ctr\_d\_delta - Ctr Max/Min Derivative difference =  $Ctr\_dmax - Ctr\_dmin$   
 Ctr\_pk\_delta - Ctr peak/valley frequency difference =  $Ctr\_fval - Ctr\_fpk$   
 Ctr\_val - Value of  $Ctr(f)$  at frequency  $Ctr\_fval$

Ctg\_dmax - Maximum positive slope of  $Ctg(f) = \max(\text{derivative}(Ctg(f)/df))$   
 Ctg\_fmax - Frequency at which Ctg\_dmax occurs  
 Ctg\_dmin - Maximum negative slope of  $Ctg(f) = \min(\text{derivative}(Ctg(f)/df))$   
 Ctg\_fmin - Frequency at which Ctg\_dmin occurs  
 Ctg\_d\_delta - Ctg Max/Min Derivative difference =  $Ctg\_dmax - Ctg\_dmin$

Str\_dmax - Maximum positive slope of  $Str(f) = \max(\text{derivative}(Str(f)/df))$   
 Str\_fmax - Frequency at which Str\_dmax occurs  
 Str\_dmin - Maximum negative slope of  $Str(f) = \min(\text{derivative}(Str(f)/df))$   
 Str\_fmin - Frequency at which Str\_dmin occurs

**150Hz-20KHz Secondary Derived Measurements:**

Str\_fpk - Frequency of first peak (local maxima) in Str(f)  
 Str\_fval - Frequency of first valley (local minima) in Str(f)  
 Str\_d\_delta - Str Max/Min Derivative difference = Str\_dmax-Str\_dmin  
 Str\_pk\_delta - Str peak/valley frequency difference = Str\_fval-Str\_fpk  
 Str\_pk - Value of Str(f) at frequency Str\_fpk  
 Str\_val - Value of Str(f) at frequency Str\_fval  
 Str\_delta - Str peak/valley difference = Str\_pk-Str\_val  
  
 Stg\_dmax - Maximum positive slope of Stg(f) = max(derivative(Stg(f)/df))  
 Stg\_fmax - Frequency at which Stg\_dmax occurs  
 Stg\_dmin - Maximum negative slope of Stg(f) = min(derivative(Stg(f)/df))  
 Stg\_fmin - Frequency at which Stg\_dmin occurs  
 Stg\_fpk - Frequency of first peak (local maxima) in Stg(f)  
 Stg\_fval - Frequency of first valley (local minima) in Stg(f)  
 Stg\_d\_delta - Stg Max/Min Derivative difference = Stg\_dmax-Stg\_dmin  
 Stg\_pk\_delta - Stg peak/valley frequency difference = Stg\_fval-Stg\_fpk  
  
 Gtg20k/Gtg8k - Ratio of Gtg at 19950Hz and 8250Hz  
 Gtg20k/Gtg4k - Ratio of Gtg at 19950Hz and 4200Hz  
 Cgt30/Cgt20k - Ratio of Ctg at 30Hz and 19950Hz  
 Cgt30/Cgt8k - Ratio of Ctg at 30Hz and 8250Hz

What is claimed is:

1. A method of determining a physical structure of a subscriber line, comprising:

5 searching a reference set for a match between the subscriber line and a model line of the reference set, the match being based on electrical properties of the lines; and

10 identifying that the subscriber line has a specific physical structure in response to finding a match with one of the model lines that has the specific physical structure.

2. The method of claim 1, further comprising:

15 performing electrical measurements to determine the electrical properties, the electrical measurements being one-ended measurements.

3. The method of claim 2, wherein the act of  
20 searching comprises:

evaluating an error function for each model line to determine quality of the match between values of the electrical properties of the model and subscriber lines.

25 4. The method of claim 2, wherein the one-ended measurements determine one of a tip-to-ring admittance, a tip-to-ground admittance, and a ring-to-ground admittance.

30 5. The method of claim 4, wherein the electrical properties include a quantity representative of a phase of an impedance of the subscriber line.

6. The method of claim 4, wherein the act of

performing includes transmitting a voltage signal to the subscriber line through a test access of a switch or a DSLAM device.

5           7. The method of claim 2, wherein the act of identifying indicates that the subscriber line has one or more bridged taps in response to the matching model line having one or more bridged taps.

10           8. The method of claim 2, wherein the act of identifying indicates that the subscriber line has a mixture of gauges in response to the matching model having a mixture of gauges.

15           9. The method of claim 2, wherein the act of searching for comprises:  
            looking up values of the electrical properties of the model lines in a data storage device.

20           10. The method of claim 2, wherein the act of searching comprises:  
            computing values of a portion of the electrical properties of the model lines using a reference equation.

25           11. The method of claim 2, wherein the one-ended measurements are performed at a plurality of frequencies.

            12. The method of claim 11, further comprising:  
            calculating a value of signal attenuation for the  
30 subscriber line from the one-ended measurements; and  
            increasing the calculated value in response to determining that the line has a bridged tap.

13. A method of qualifying a subscriber line for a data service, comprising:

searching a reference set of model lines for a best match to a subscriber line by comparing sets of electrical properties;

determining that the subscriber line has a specific physical structure in response to the best matching model line having the specific physical structure; and

disqualifying the subscriber line for the data service, in part, in response to determining that the specific physical structure corresponds to a disqualified line.

14. The method of claim 13, wherein the electrical properties are obtained from one-ended measurements on the subscriber line.

15. The method of claim 14, wherein the act of searching for a best match comprises:

evaluating an error function for each model line to determine quality of correspondence between the electrical properties of the model line and of the subscriber line.

16. The method of claim 14, wherein the compared properties include a quantity indicative of the phase an impedance of the subscriber line.

17. The method of claim 14, further comprising: making one-ended electrical measurements on the subscriber line at a plurality of frequencies to obtain the electrical properties.

18. The method of claim 17, further comprising:  
calculating a value of signal attenuation for the  
subscriber line from the one-ended measurements; and  
increasing the value in response to determining that  
5 the line has a bridged tap.

19. The method of claim 18, wherein the act of  
disqualifying is responsive to the increased value being  
greater than a predetermined threshold value for the data  
10 service.

20. The method of claim 17, wherein the one-ended  
measurements determine one of a tip-to-ring admittance, a  
tip-to-ground admittance, and a ring-to-ground  
15 admittance.

21. The method of claim 17, wherein the making one-  
ended measurements includes driving the subscriber line  
through a test access of a switch or DSLAM device.  
20

22. A method of providing a data service,  
comprising:  
searching a reference set of model lines for a best  
match to a subscriber's line by comparing measured  
25 electrical properties to properties of the model lines;  
determining whether the subscriber's line is  
qualified for the data service based in part on whether  
the best matching model line has a one of a bridged tap  
and a mixture of gauges; and  
30 performing a business action in response to  
determining that the subscriber's line is qualified.

23. The method of claim 22, wherein the business

action includes offering one of the data service and a service quality-level agreement to the subscriber.

24. The method of claim 22, wherein the act of  
5 offering comprises:

performing one of a repair and a replacement of the subscriber line in response to determining that subscriber line is disqualified.

10 25. The method of claim 22, further comprising:

repeating the acts of searching, determining, and performing for a plurality of subscriber lines connected to one telephony switch or one DSLAM device.

15 26. The method of claim 22, wherein the act of searching for a best match comprises:

20 evaluating an error function for each model line to determine quality of a correspondence between the electrical properties of the model line and the subscriber line.

27. The method of claim 22, wherein the compared properties include a quantity indicative of a phase of an impedance of the subscriber line.

25 28. The method of claim 22, further comprising:  
performing one-ended electrical measurements at a plurality of frequencies to obtain the electrical properties.

30 29. The method of claim 22, wherein the act of determining further comprises:  
calculating a value of a signal attenuation for the



subscriber line from the one-ended measurements;

increasing the value in response to determining that the line has a bridged tap or a mixture of gauges; and

wherein the act of qualifying is responsive to the  
5 increased value being less than a predetermined threshold value for the data service.

30. A data storage device storing an executable program of instructions for determining a structure of a  
10 subscriber line, the instructions to cause a computer to:

search a reference set for a match between the subscriber line and a model line of a reference set, the match being based on electrical properties of the lines;  
and

15 identify that the subscriber line has a specific physical structure in response to finding a match with one of the model lines that has the specific physical structure.

20 31. The device of claim 30, wherein the electrical properties are determined from one-ended measurements.

32. The device of claim 30, wherein the instructions to search cause the computer to:

25 evaluate an error function for each model line to determine quality of the match between values of the electrical properties of the model and subscriber lines.

30 33. The device of claim 30, wherein the electrical properties include a quantity representative of a phase of an impedance of the subscriber line.

34. The device of claim 31, wherein the

instructions to identify cause the computer to indicate that the subscriber line has one or more bridged taps in response to the matching model line having one or more bridged taps.

5

35. The device of claim 31, wherein the instructions to identify cause the computer to indicate that the subscriber line has a mixture of gauges in response to the matching model having a mixture of gauges.

10

36. The device of claim 31, wherein the electrical properties in a property at a plurality of frequencies.

15

37. The device of claim 31, the instructions further causing the computer to:

calculate a value of signal attenuation for the subscriber line from the one-ended measurements; and

increase the calculated value in response to determining that the line has a bridged tap.

20



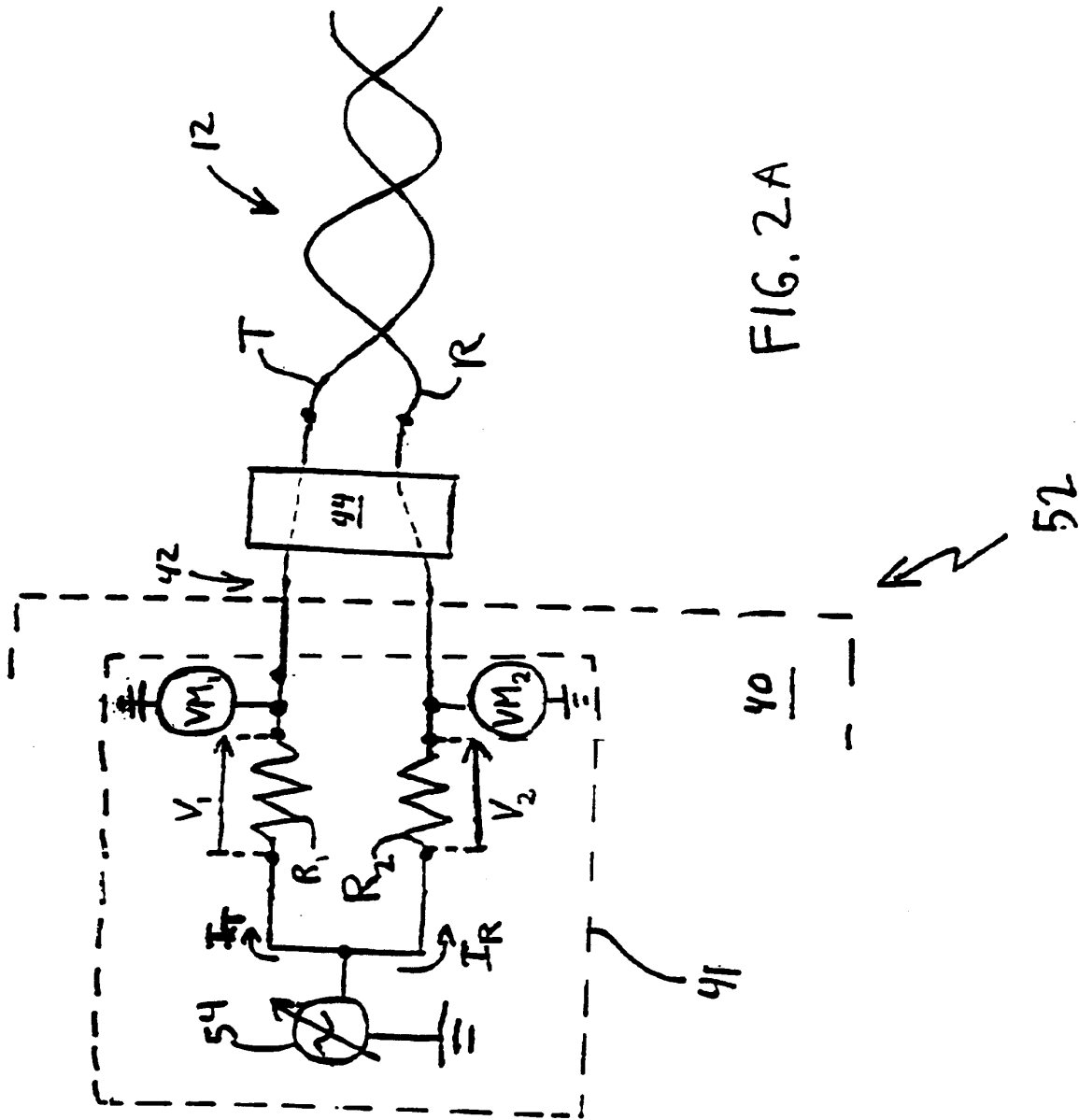
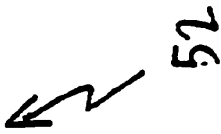

FIG. 2A



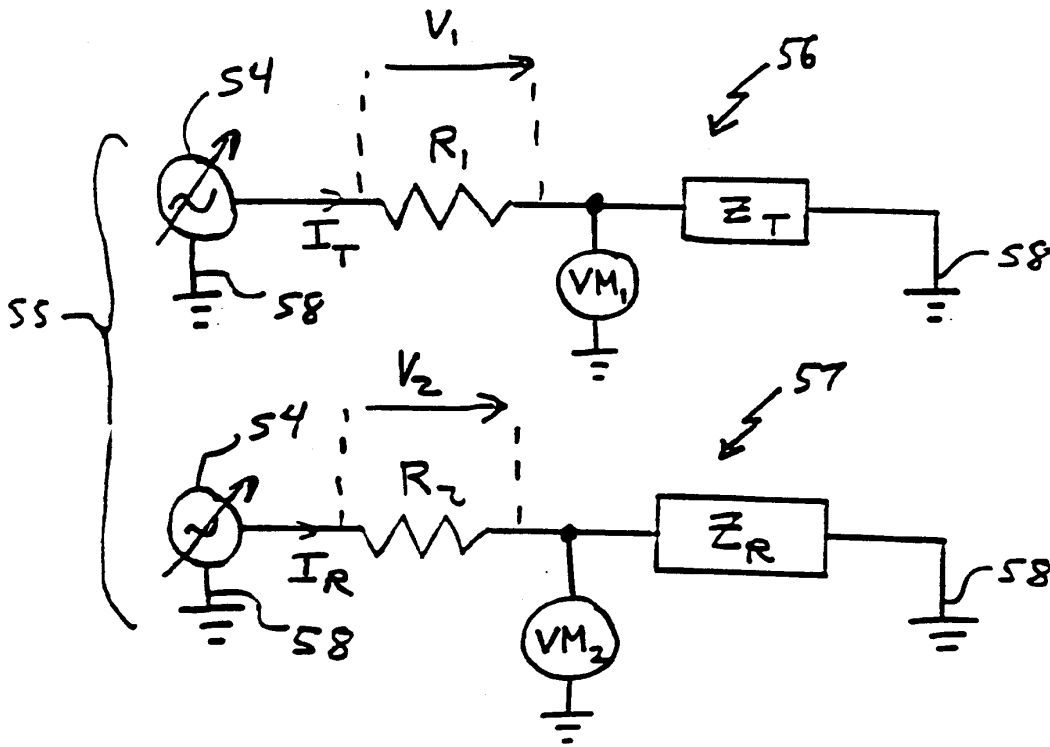

FIG. 2B

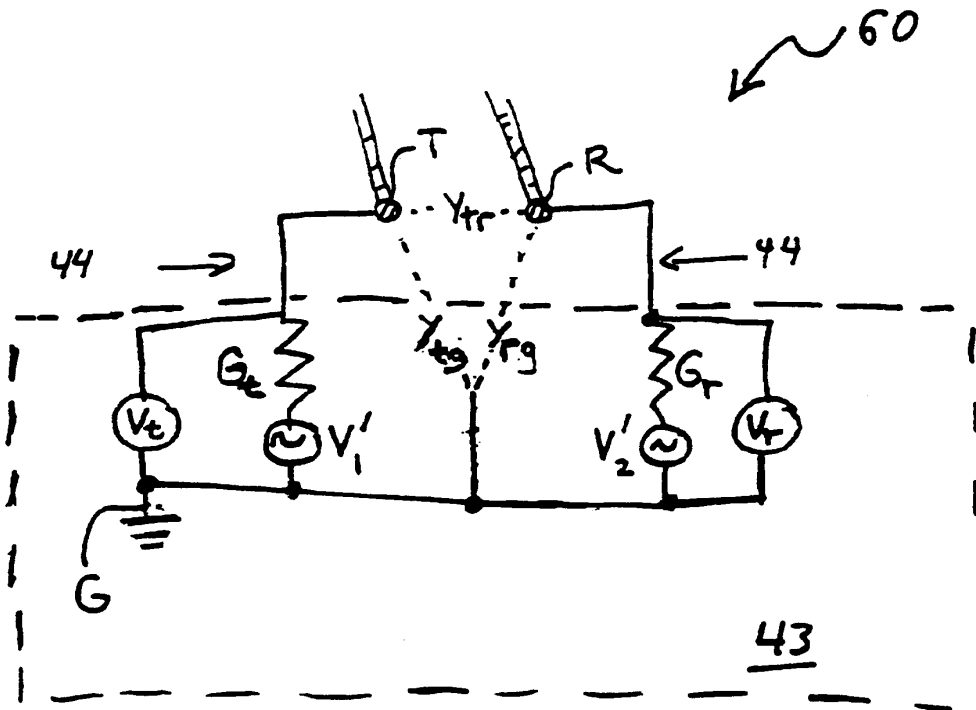

FIG. 2C

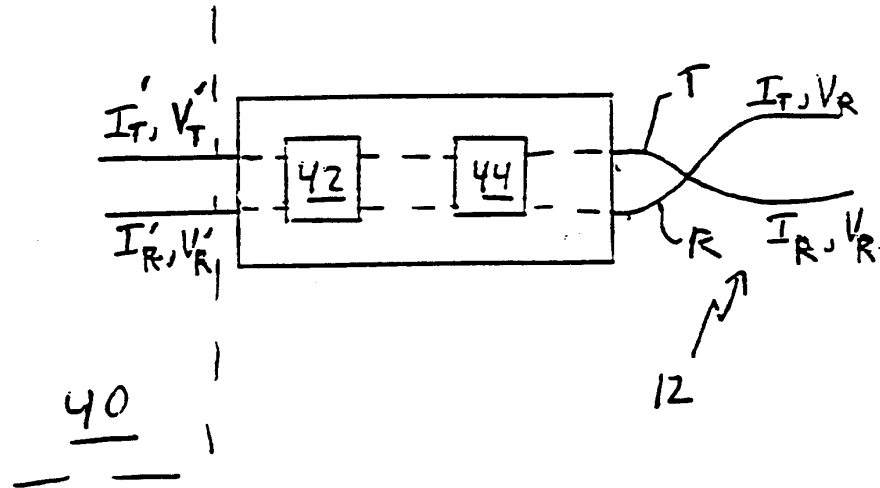
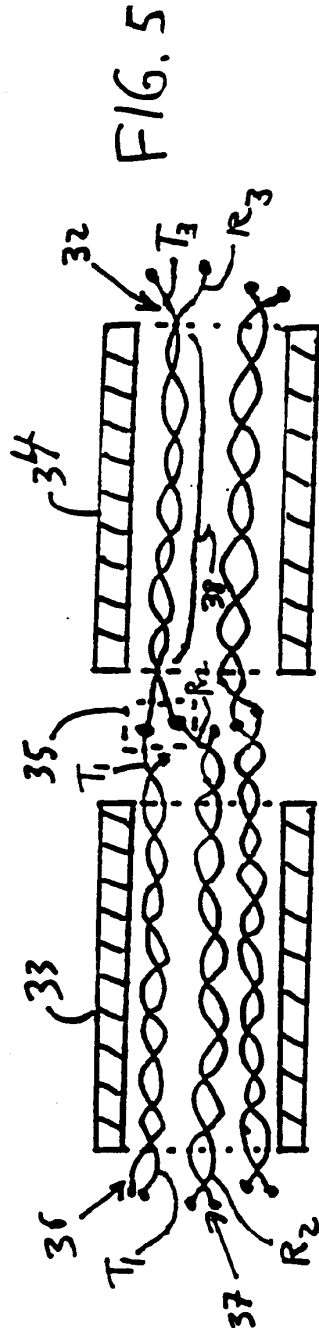
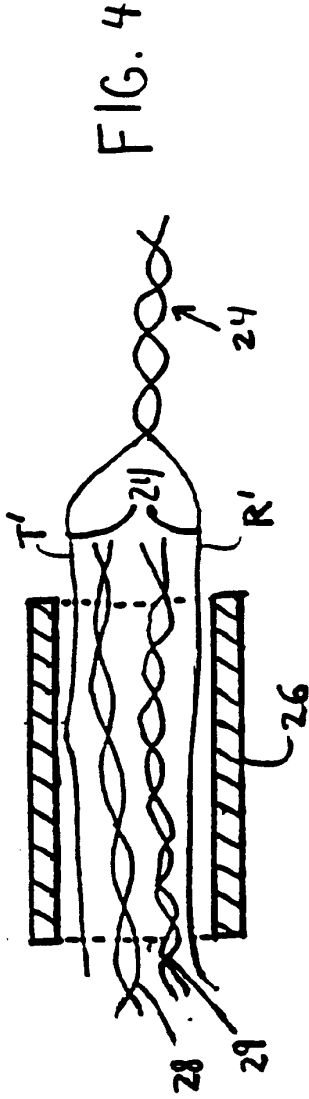

FIG. 3





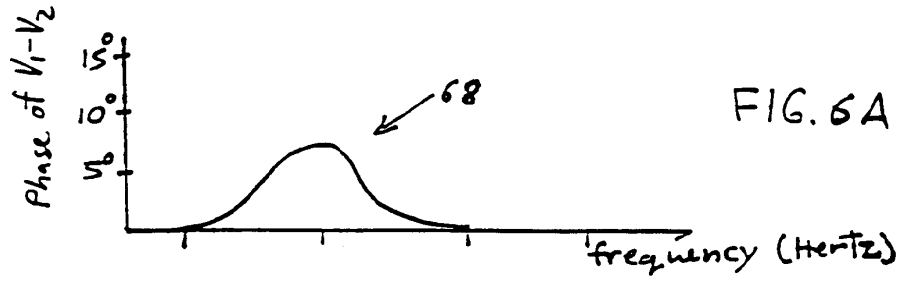

FIG. 6A

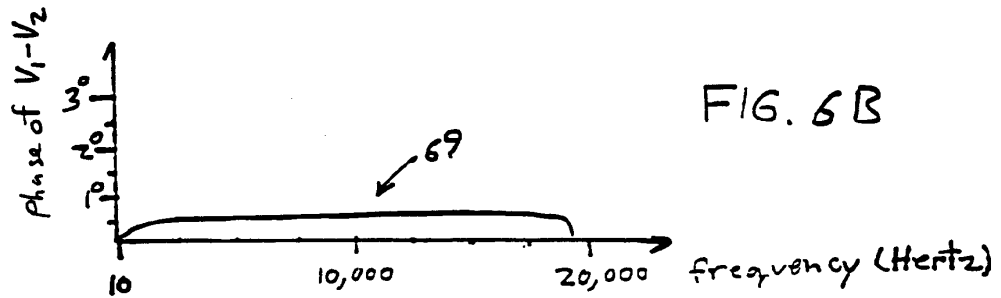
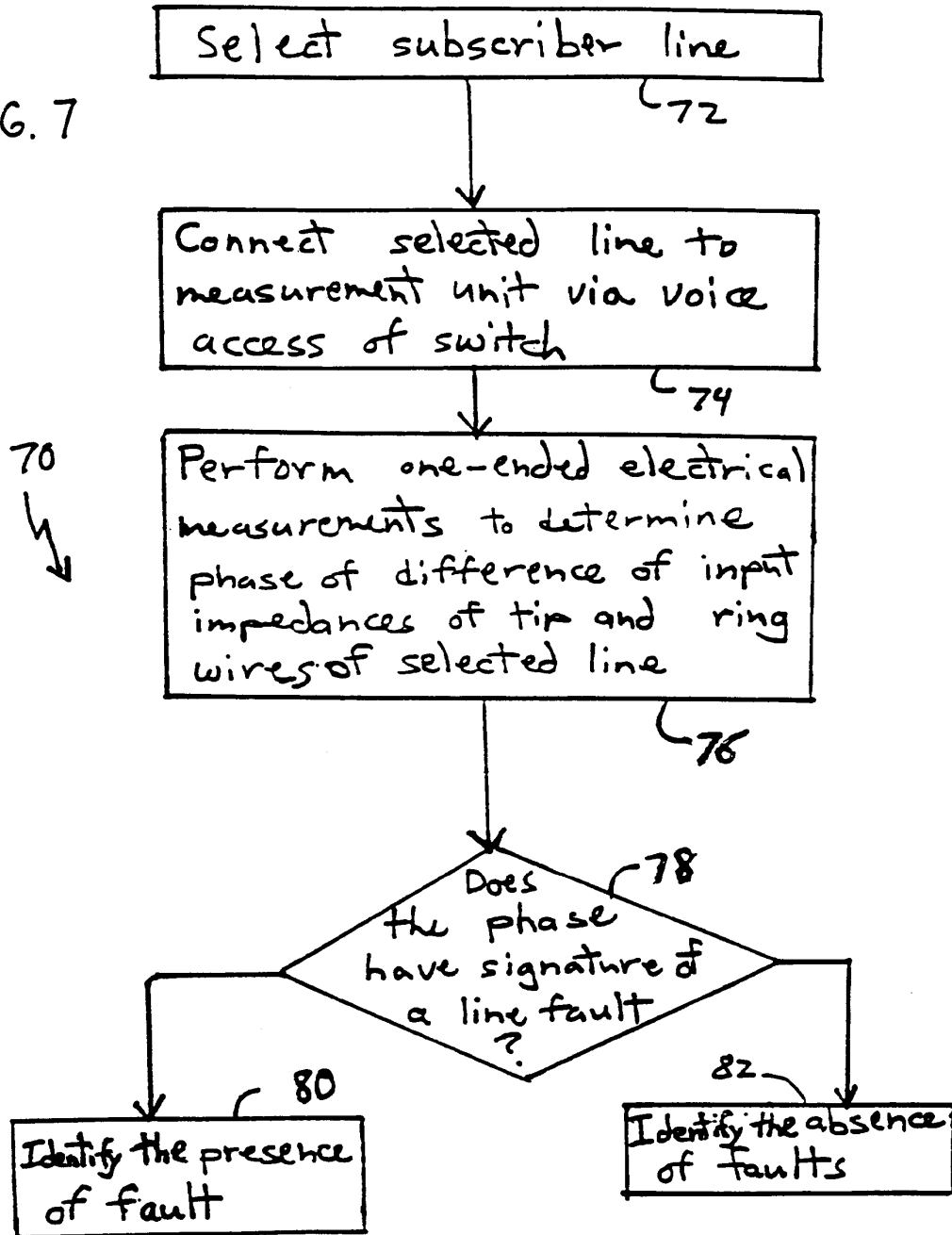

FIG. 6B

FIG. 7



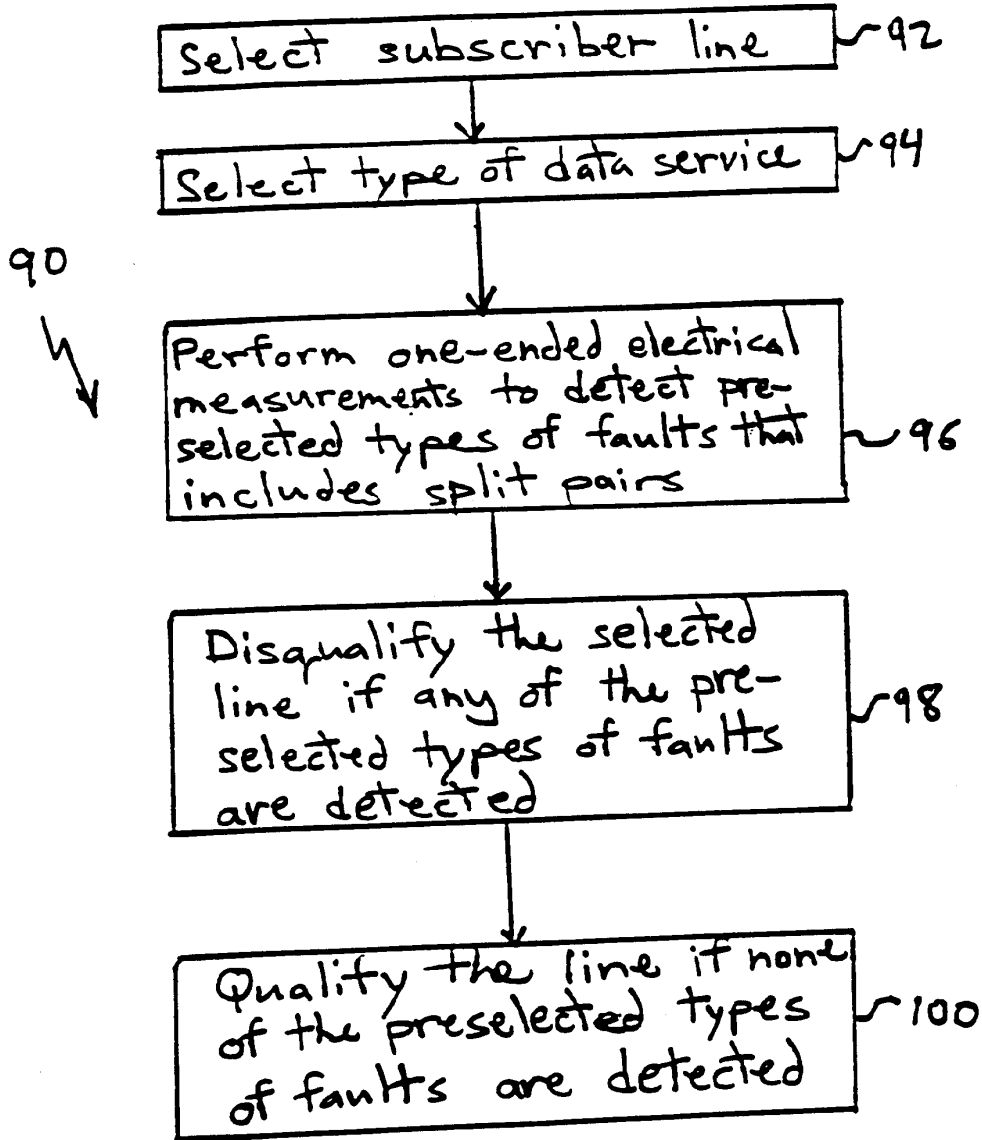

FIG. 8

10 / 25

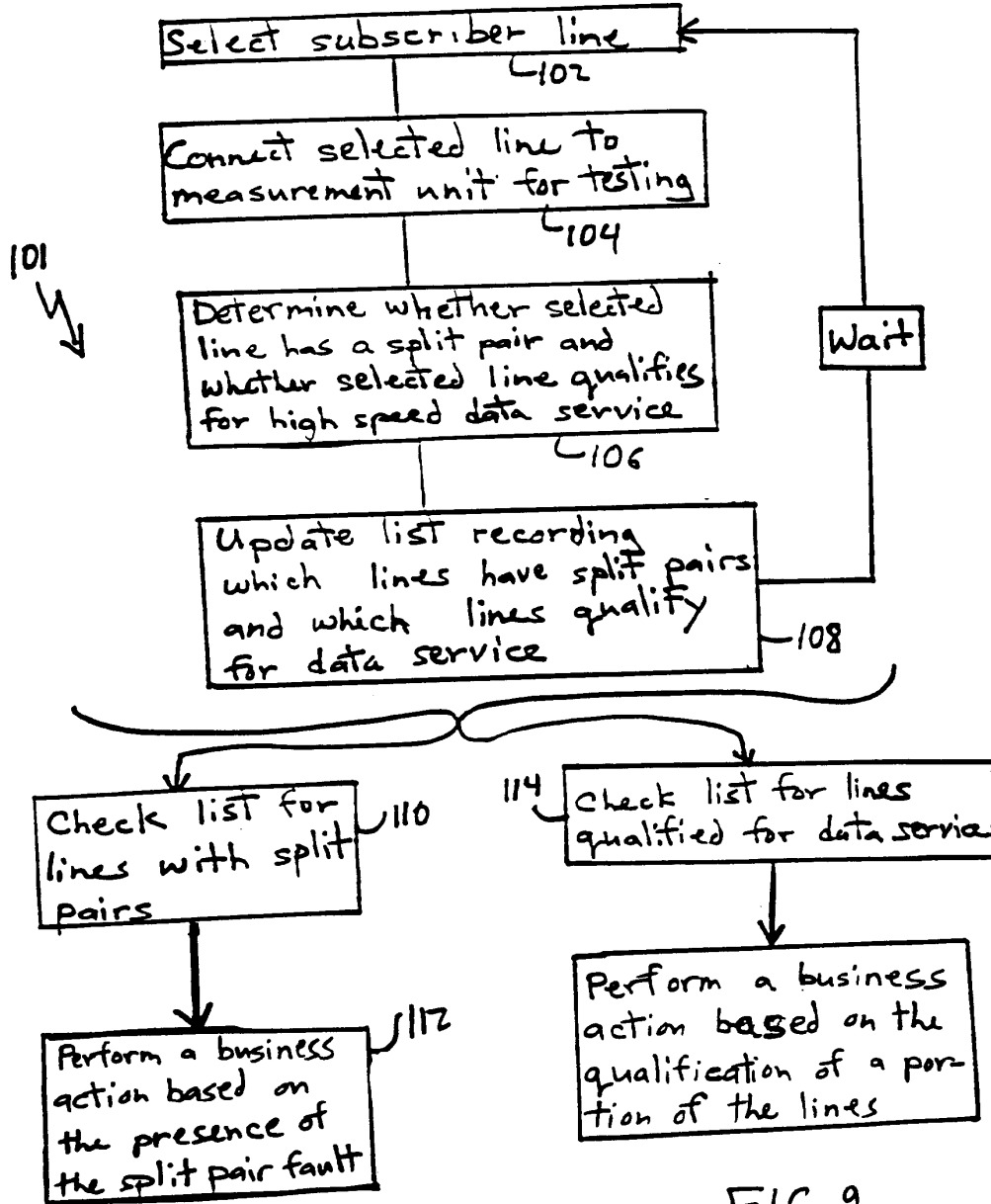

FIG. 9



FIG. 10 A

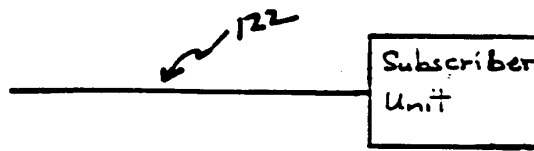

FIG. 10 B

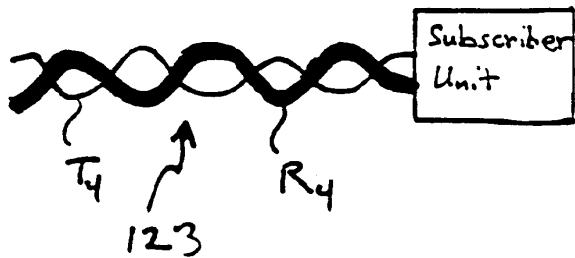

FIG. 10 C

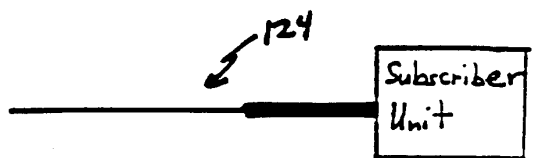

FIG. 10 D

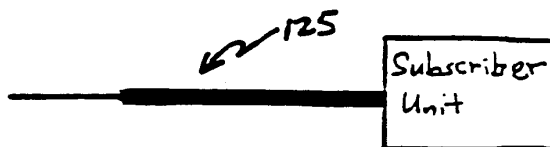

FIG. 10 E

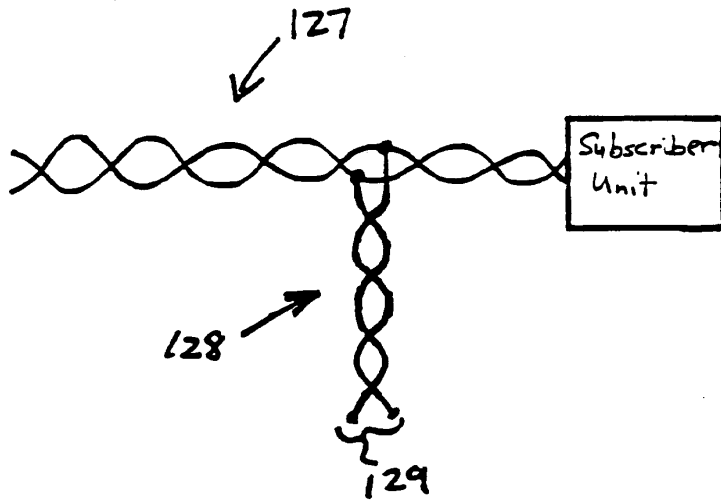

FIG. 11

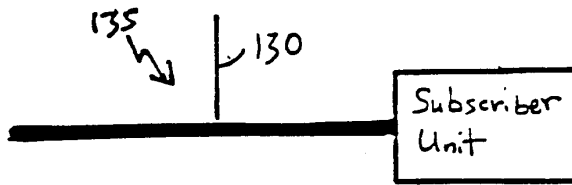

FIG. 12 A

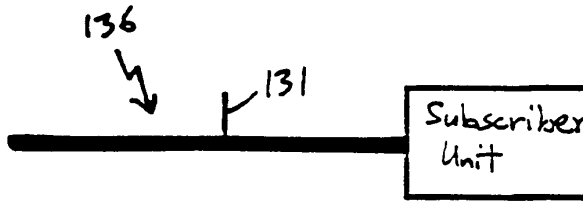

FIG. 12 B

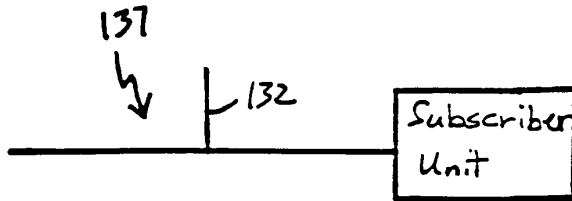

FIG. 12 C

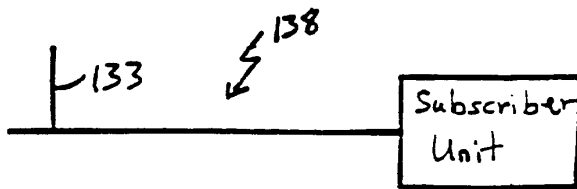

FIG. 12 D

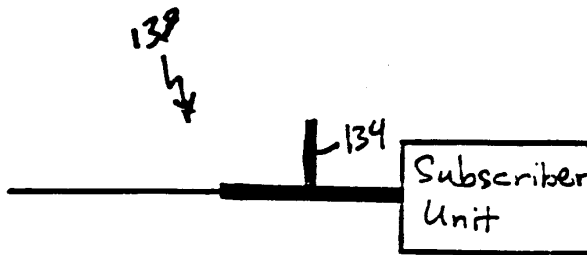

FIG. 12 E

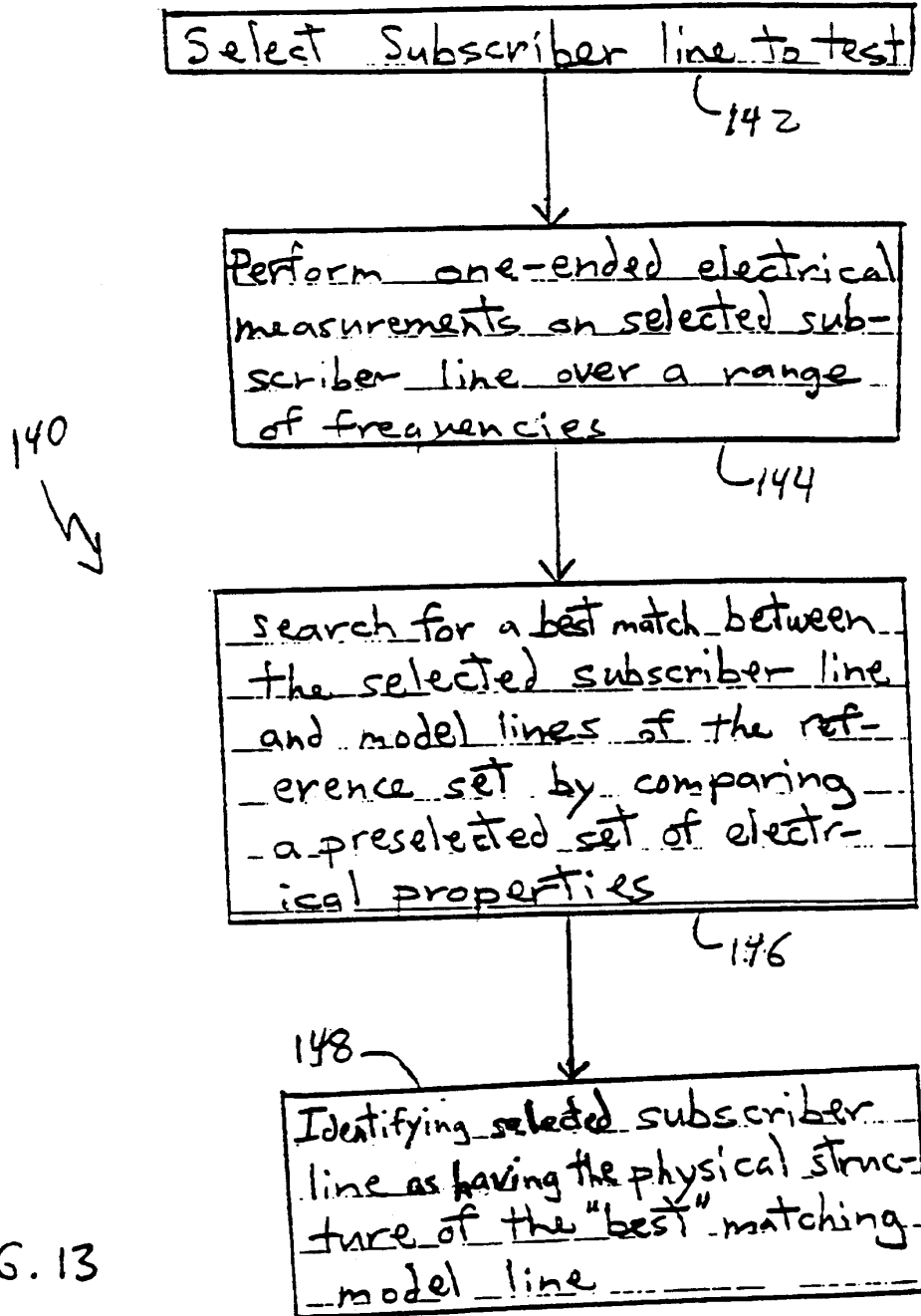

FIG. 13



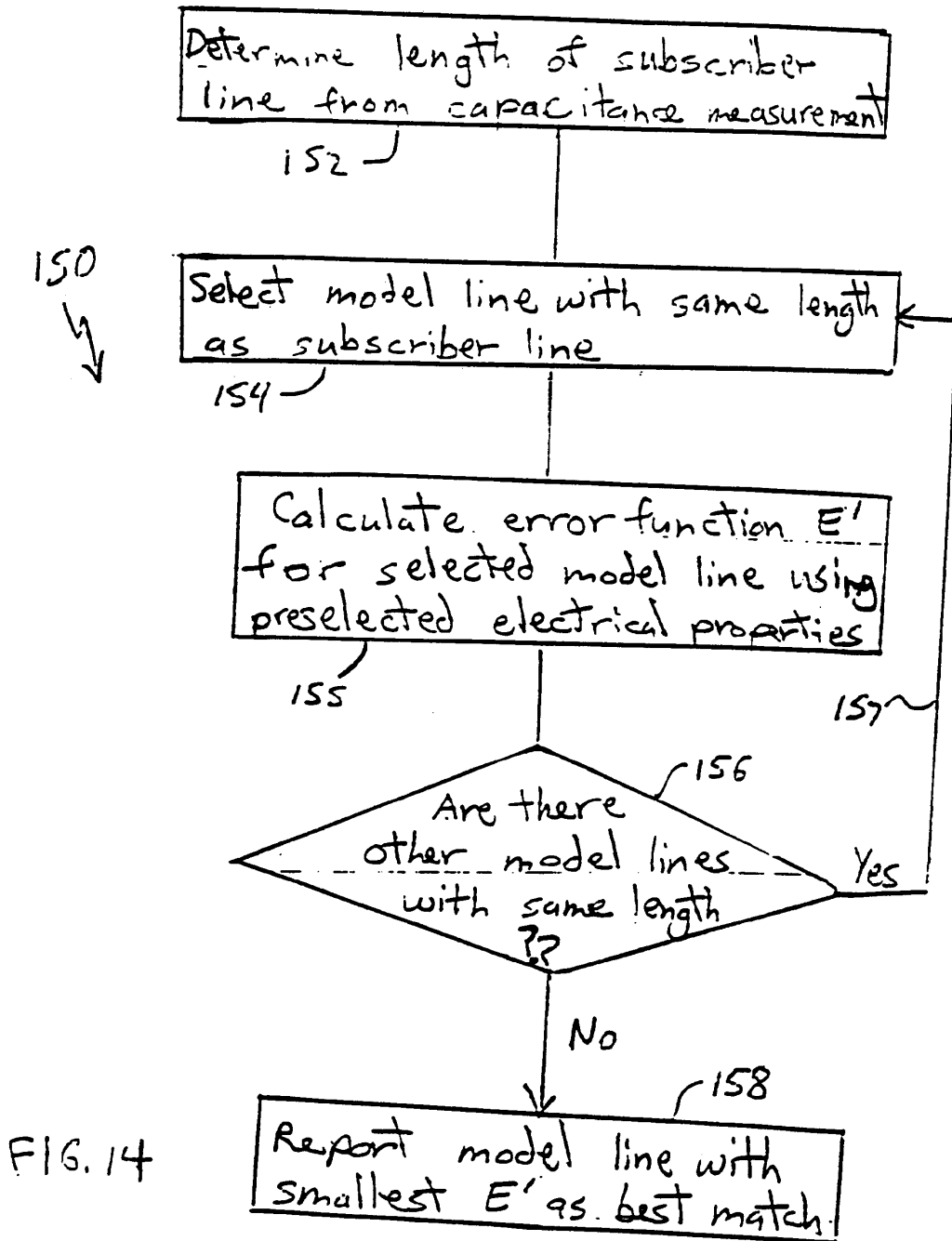

FIG. 14

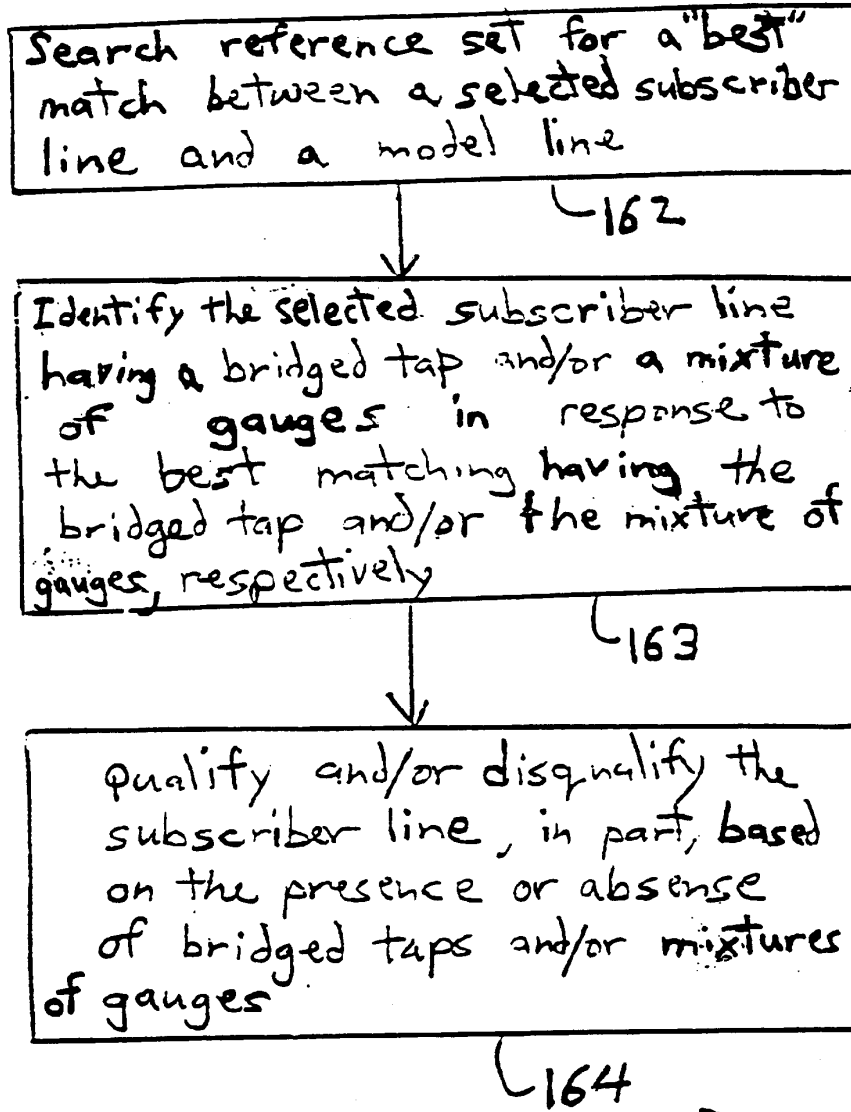
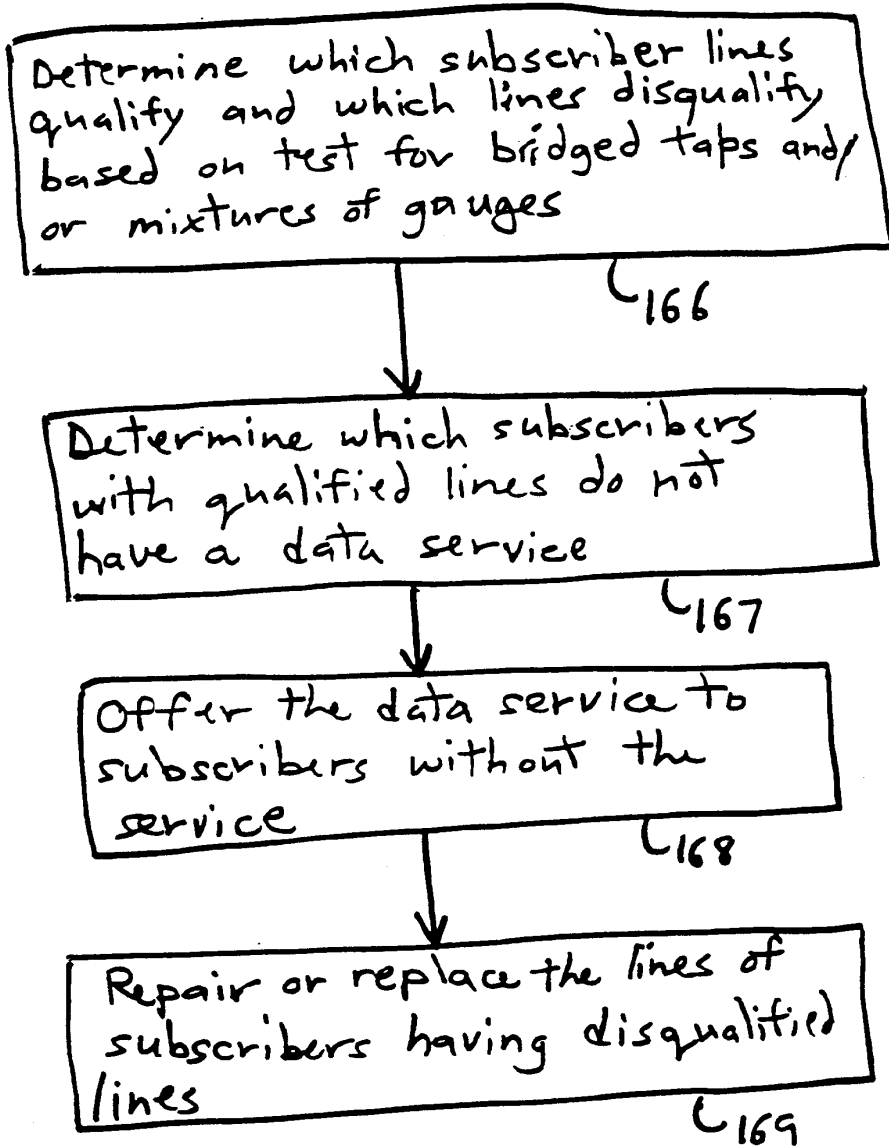

FIG. 15



165 ↗

FIG. 16

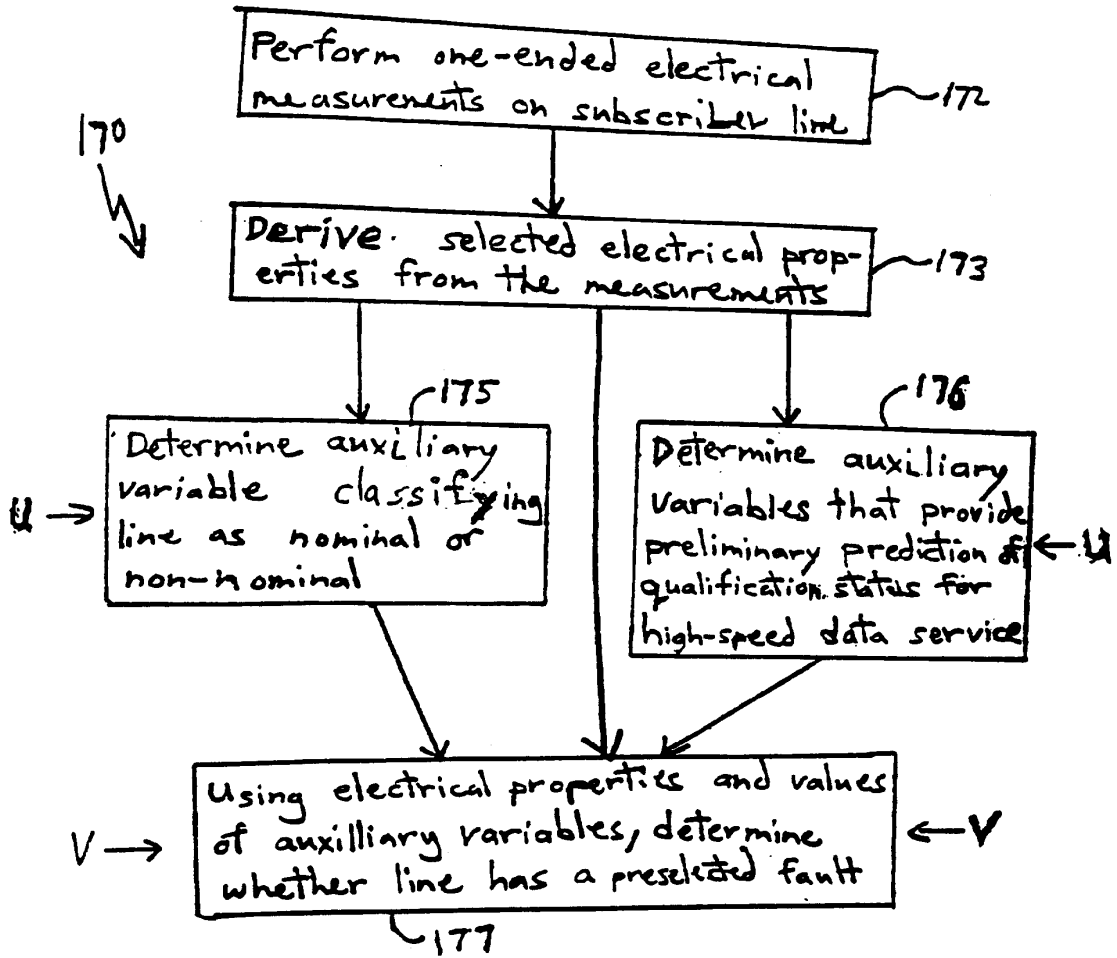

FIG. 17

FIG. 18A

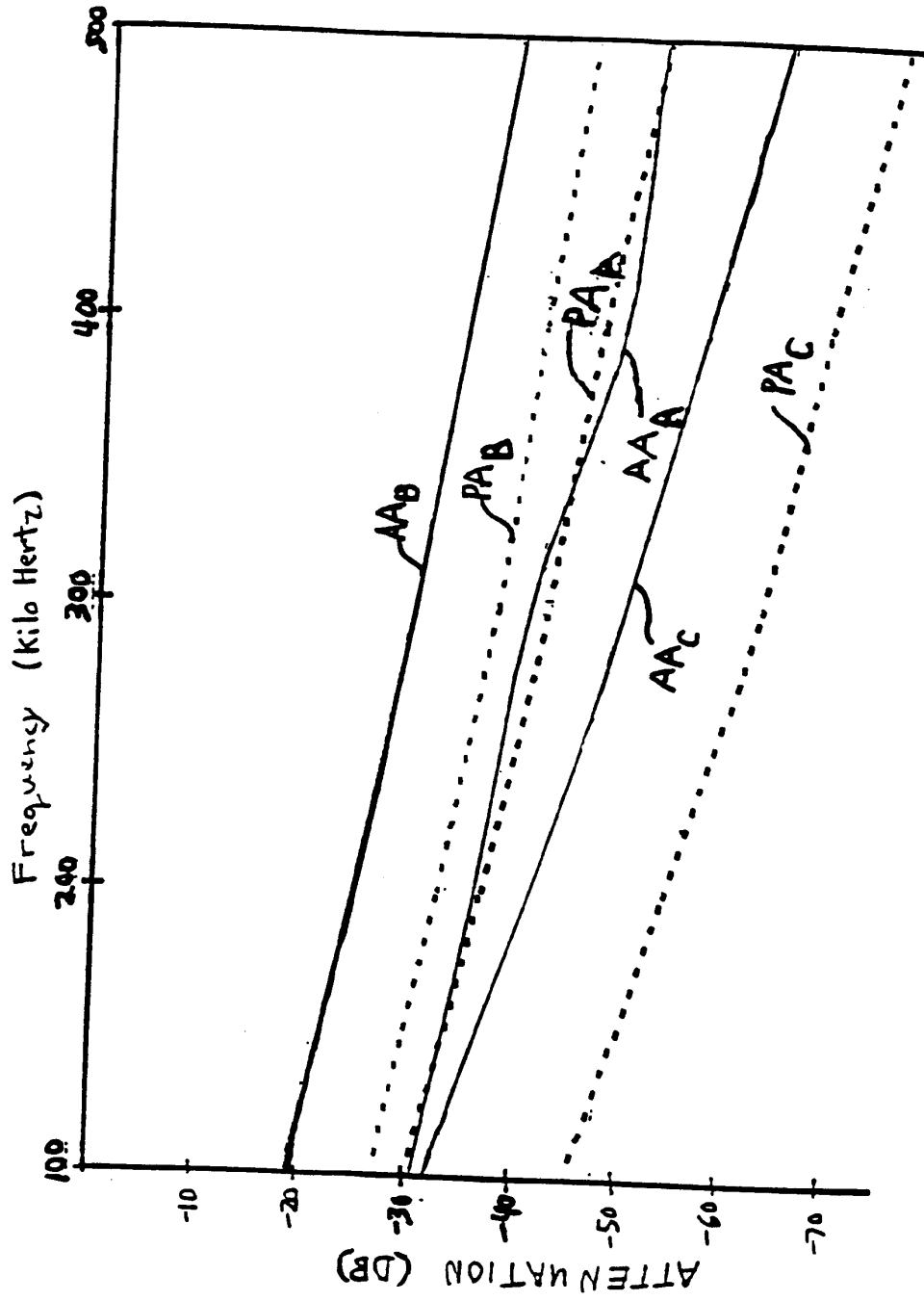

FIG. 18B

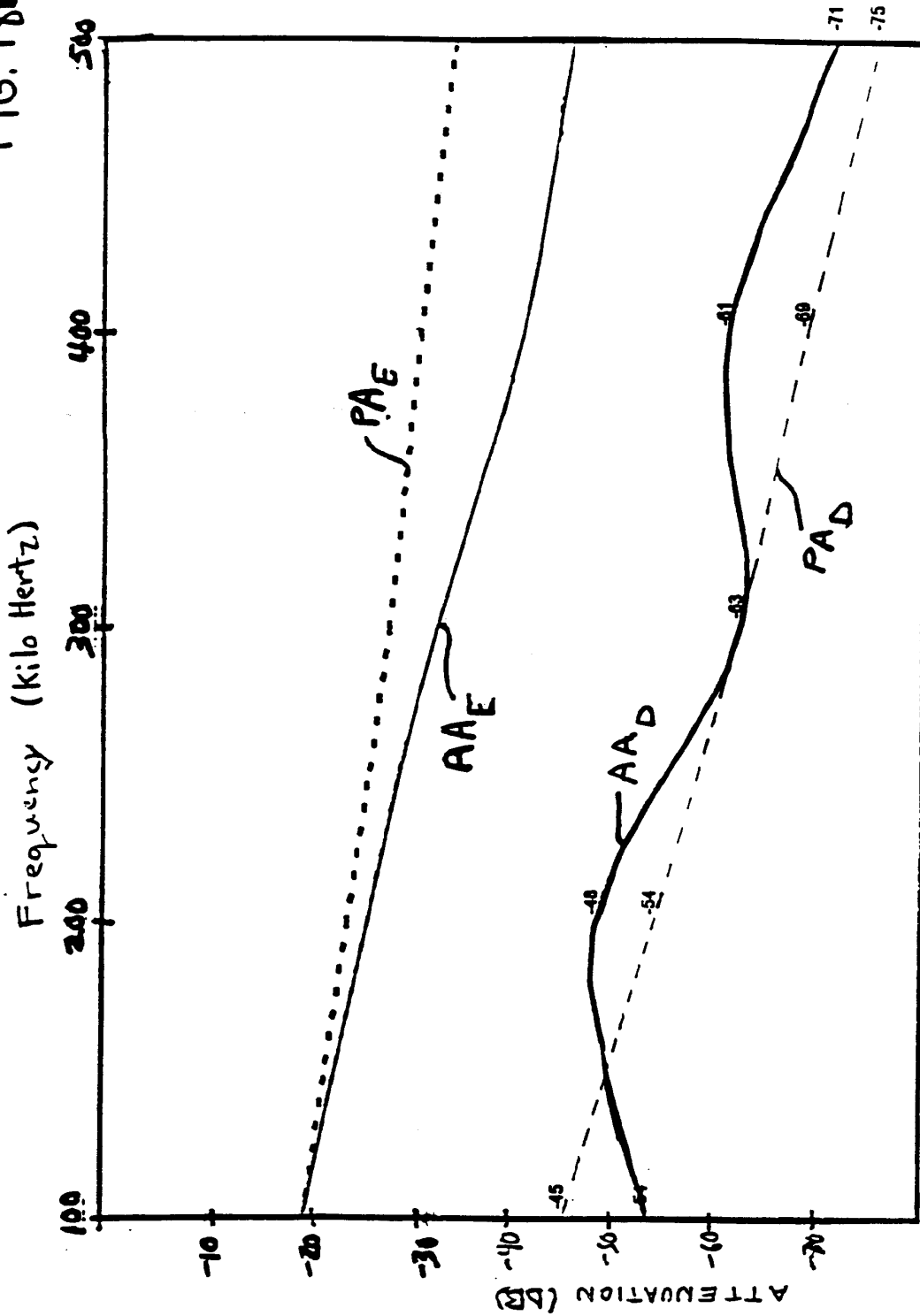
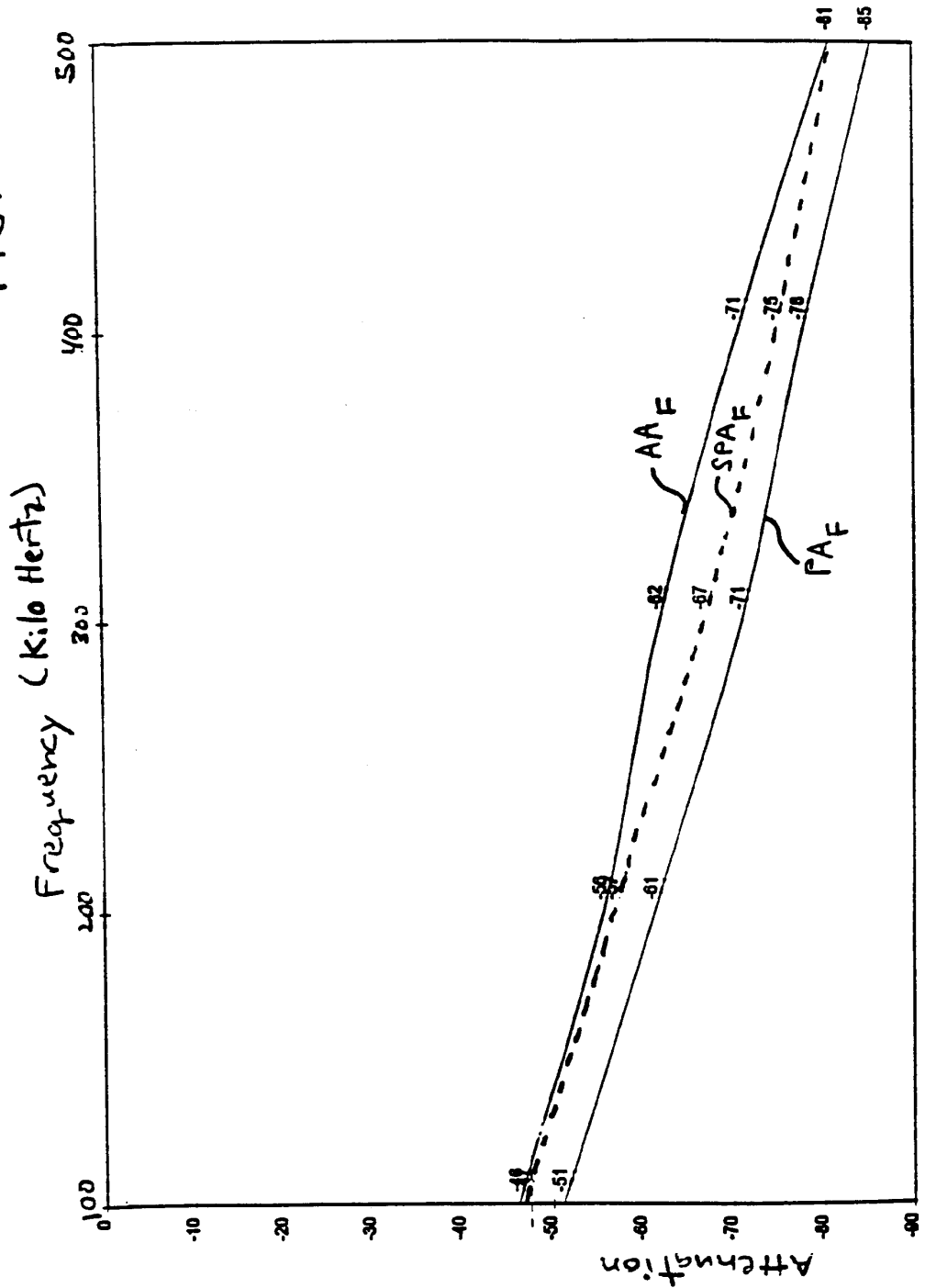

FIG. 18C



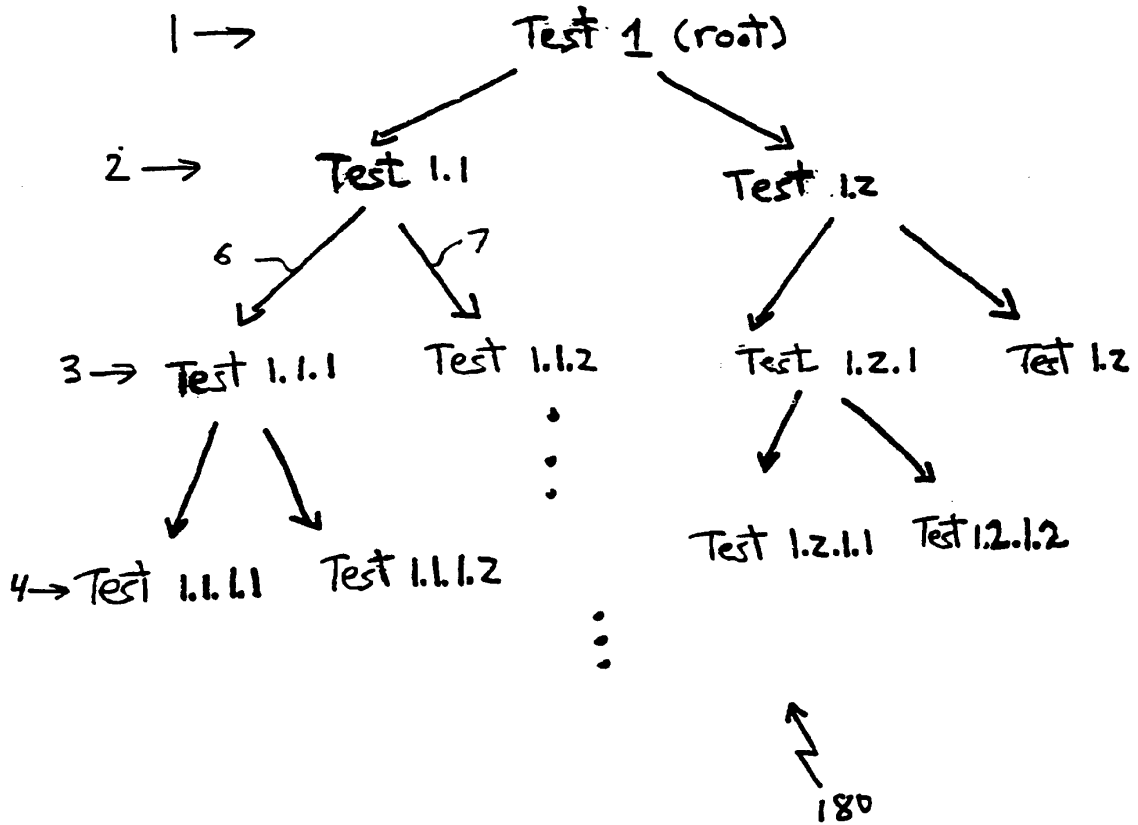
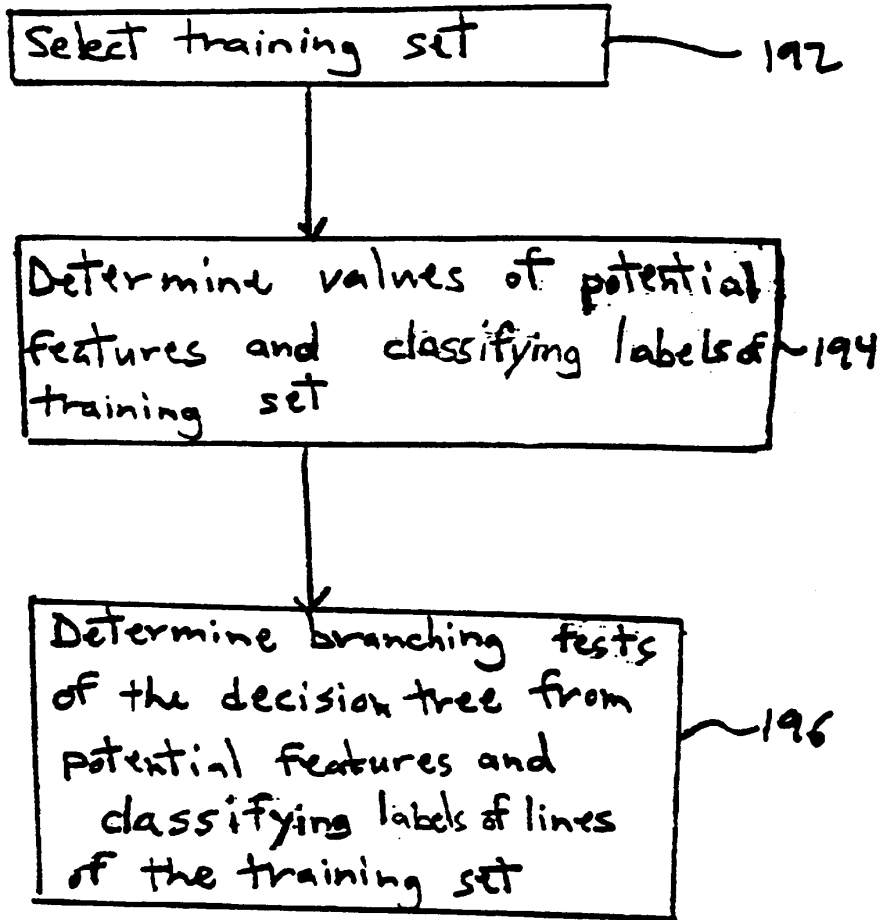

FIG. 19







190 ↗

FIG. 21

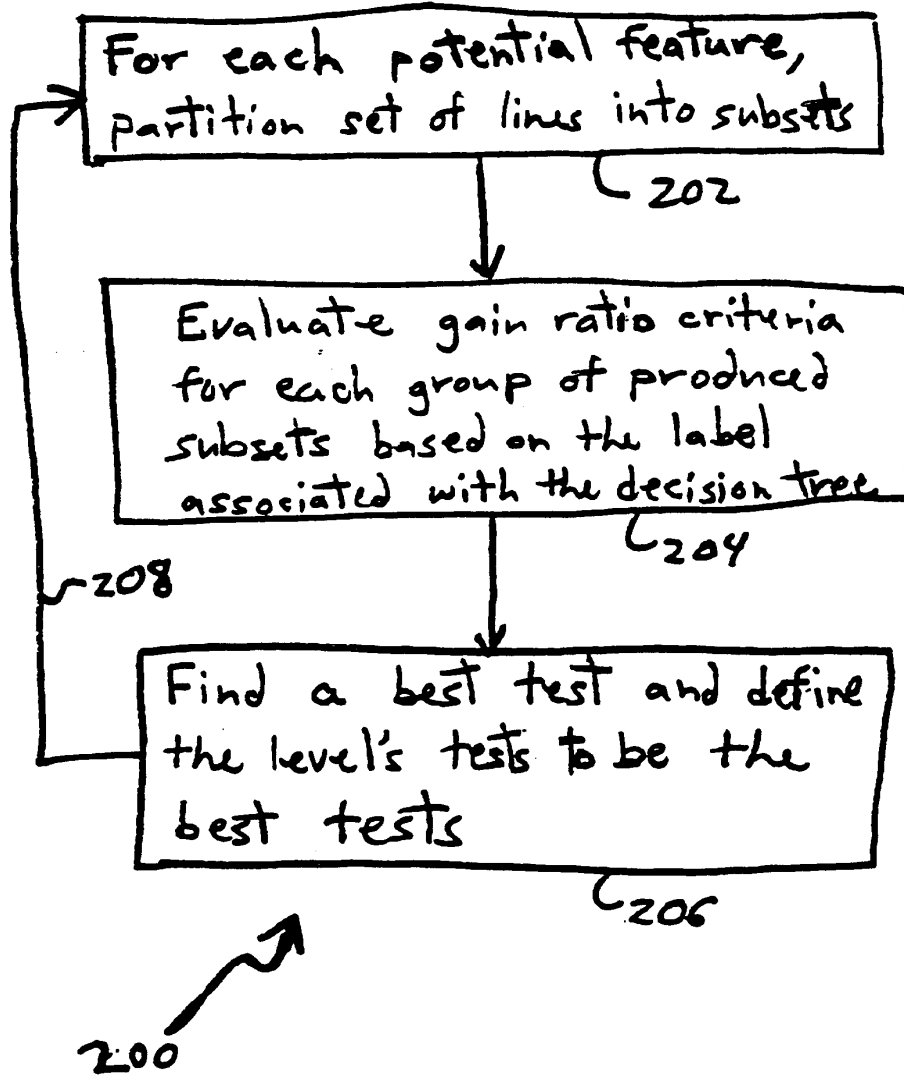

FIG. 22



INTERNATIONAL APPLICATION PUBLISHED UNDER THE PATENT COOPERATION TREATY (PCT)

<p>(51) International Patent Classification 4 : H04M 11/00, H04B 15/00, 1/10 H04L 5/00, 25/08, H04B 1/10</p>	<p>A1</p>	<p>(11) International Publication Number: WO 86/ 07223 (43) International Publication Date: 4 December 1986 (04.12.86)</p>
<p>(21) International Application Number: PCT/US86/00983 (22) International Filing Date: 5 May 1986 (05.05.86) (31) Priority Application Number: 736,200 (32) Priority Date: 20 May 1985 (20.05.85) (33) Priority Country: US  (71) Applicant: TELEBIT CORPORATION [US/US]; 10440 Bubb Road, Cupertino, CA 95014 (US). (72) Inventor: HUGHES-HARTOGS, Dirk ; 2220 Rolling Hills Drive, Morgan Hill, CA 95037 (US). (74) Agent: ALLEN, Kenneth, R.; Townsend and Townsend, One Market Plaza, San Francisco, CA 94105 (US).</p>		<p>(81) Designated States: AT (European patent), AU, BE (European patent), BR, CH (European patent), DE (European patent), DK, FR (European patent), GB (European patent), IT (European patent), JP, KR, LU (European patent), NL (European patent), NO, SE (European patent).  Published With international search report.</p>

(54) Title: ENSEMBLE MODEM STRUCTURE FOR IMPERFECT TRANSMISSION MEDIA

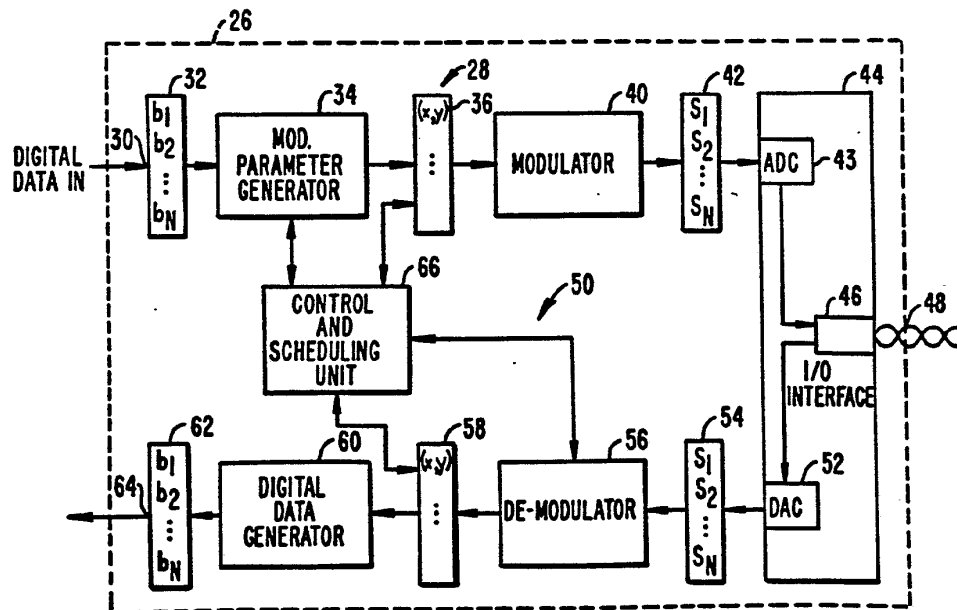

(57) Abstract

A high speed modem (26) that transmits and receives digital data on an ensemble of carrier frequencies spanning the usable band of a dial-up telephone line (48). The modem includes a system (30, 32, 34, 36, 40, 43, 44) for variably allocating data and power among the carriers to compensate for equivalent noise and to maximize the data rate. Additionally, systems for eliminating the need for an equalization network, for adaptively allocating control of a channel, and for tracking variations in line parameters are disclosed.

**FOR THE PURPOSES OF INFORMATION ONLY**

Codes used to identify States party to the PCT on the front pages of pamphlets publishing international applications under the PCT.

AT	Austria	GA	Gabon	MR	Mauritania
AU	Australia	GB	United Kingdom	MW	Malawi
BB	Barbados	HU	Hungary	NL	Netherlands
BE	Belgium	IT	Italy	NO	Norway
BG	Bulgaria	JP	Japan	RO	Romania
BR	Brazil	KP	Democratic People's Republic of Korea	SD	Sudan
CF	Central African Republic	KR	Republic of Korea	SE	Sweden
CG	Congo	LI	Liechtenstein	SN	Senegal
CH	Switzerland	LK	Sri Lanka	SU	Soviet Union
CM	Cameroon	LU	Luxembourg	TD	Chad
DE	Germany, Federal Republic of	MC	Monaco	TG	Togo
DK	Denmark	MG	Madagascar	US	United States of America
FI	Finland	ML	Mali		
FR	France				

ENSEMBLE MODEM STRUCTURE FOR  
IMPERFECT TRANSMISSION MEDIA

BACKGROUND OF THE INVENTION

5 1. Field of the Invention:

The invention relates generally to the field of data communications and, more particularly, to a high speed modem.

2. Description of the Prior Art:

10 Recently, specially designed telephone lines for the direct transmission of digital data have been introduced. However, the vast majority of telephone lines are designed to carry analog voice frequency (VF) signals. Modems are utilized to modulate VF carrier  
15 signals to encode digital information on the VF carrier signals and to demodulate the signals to decode the digital information carried by the signal.

Existing VF telephone lines have several limitations that degrade the performance of modems and  
20 limit the rate at which data can be transmitted below desired error rates. These limitations include the presence of frequency dependent noise on the VF telephone lines, a frequency dependent phase delay induced by the VF telephone lines, and frequency dependent sig-  
25 nal loss.

Generally, the usable band of a VF telephone line is from slightly above zero to about four kHz. The power spectrum of the line noise is not uniformly distributed over frequency and is generally not deter-  
30 minative. Thus, there is no a priori method for determining the distribution of the noise spectrum over the usable bandwidth of the VF line.

Additionally, a frequency-dependent propaga-  
tion delay is induced by the VF telephone line. Thus,  
35 for a complex multi-frequency signal, a phase delay

between the various components of the signal will be induced by the VF telephone line. Again, this phase delay is not determinative and must be measured for an individual VF telephone line at the specific time that transmission takes place.

Further, the signal loss over the VF telephone line varies with frequency. The equivalent noise is the noise spectrum component added to the signal loss component for each carrier frequency, where both components are measured in decibels (dB).

Generally, prior art modems compensate for equivalent line noise and signal loss by gear-shifting the data rate down to achieve a satisfactory error rate. For example, in U.S. patent 4,438,511, by Baran, a high speed modem designated SM9600 Super Modem manufactured by Gandalf Data, Inc., is described. In the presence of noise impairment, the SM9600 will "gear shift" or drop back its transmitted data rate to 4800 bps or 2400 bps. The system described in the Baran patent transmits data over 64 orthogonally modulated carriers. The Baran system compensates for the frequency dependent nature of the noise on the VF line by terminating transmission on carriers having the same frequency as the frequency of large noise components on the line. Thus, Baran gracefully degrades its throughput by ceasing to transmit on carrier frequencies at the highest points of the VF line noise spectrum. The Baran system essentially makes a go/no go decision for each carrier signal, depending on the distribution of the VF line noise spectrum. This application reflects a continuation of the effort initiated by Baran.

Most prior art systems compensate for frequency dependent phase delay induced by the VF line by an equalization system. The largest phase delay is induced in frequency components near the edges of the usable band. Accordingly, the frequency components near the center of the band are delayed to allow the

frequency components at the outside of the band to catch up. Equalization generally requires additional circuitry to accomplish the above-described delays.

5           A further problem associated with two way transmission over the VF telephone line is that interference between the outgoing and incoming signals is possible. Generally, separation and isolation between the two signals is achieved in one of three ways:

10           (a) Frequency multiplexing in which different frequencies are used for the different signals. This method is common in modem-based telecommunication systems.

15           (b) Time multiplexing, in which different time segments are used for the different signals. This method is often used in half-duplex systems in which a transmitter relinquishes a channel only after sending all the data it has. And,

20           (c) Code multiplexing, in which the signals are sent using orthogonal codes.

          All of the above-described systems divide the space available according to constant proportions fixed during the initial system design. These constant proportions, however, may not be suitable to actual traffic load problem presented to each modem. For  
25           example, a clerk at a PC work station connected to a remote host computer may type ten or twenty characters and receive a full screen in return. In this case, constant proportions allocating the channel equally  
30           between the send and receive modems would greatly overallocate the channel to the PC work station clerk. Accordingly, a modem that allocates channel capacity according to the needs of the actual traffic load situation would greatly increase the efficient  
35           utilization of the channel capacity.



## SUMMARY OF THE INVENTION

The present invention is a high-speed modem for use with dial-up VF telephone lines. The modem  
5 utilizes a multicarrier modulation scheme and variably allocates data and power to the various carriers to maximize the overall data transmission rate. The allocation of power among the carriers is subject to the constraint that the total power allocated must not  
10 exceed a specified limit.

In a preferred embodiment, the modem further includes a variable allocation system for sharing control of a communication link between two modems (A and B) according to actual user requirements.

15 Another aspect of the invention is a system for compensating for frequency dependent phase delay and preventing intersymbol interference that does not require an equalization network.

According to one aspect of the invention,  
20 quadrature amplitude modulation (QAM) is utilized to encode data elements of varying complexity on each carrier. The equivalent noise component at each carrier frequency is measured over a communication link between two modems (A and B).

25 As is known in the art, if the bit error rate (BER) is to be maintained below a specified level, then the power required to transmit a data element of a given complexity on a given carrier frequency must be increased if the equivalent noise component at that  
30 frequency increases. Equivalently, to increase data complexity, the signal to noise ratio, S/N, must be increased.

In one embodiment of the present invention, data and power are allocated to maximize the overall  
35 data rate within external BER and total available power constraints. The power allocation system computes the marginal required power to increase the symbol rate on each carrier from  $n$  to  $n + 1$  information units. The

system then allocates information units to the carrier that requires the least additional power to increase its symbol rate by one information unit. Because the  
5 marginal powers are dependent on the values of the equivalent noise spectrum of the particular established transmission link, the allocation of power and data is specifically tailored to compensate for noise over this particular link.

10 According to another aspect of the invention, a first section of the symbol on each carrier is retransmitted to form a guard-time waveform of duration  $T_E + T_{PH}$  where  $T_E$  is the duration of the symbol and  $T_{PH}$  is the duration of the first section. The magnitude of  
15  $T_{PH}$  is greater than or equal to the maximum estimated phase delay for any frequency component of the waveform. For example, if the symbol is represented by the time series,  $x_0 \dots x_{n-1}$ , transmitted in time  $T_E$ ; then the guardtime waveform is represented by the time  
20 series,  $x_0 \dots x_{n-1}, x_0 \dots x_{m-1}$ , transmitted in time  $T_E + T_{PH}$ . The ratio that  $m$  bears to  $n$  is equal to the ratio that  $T_{PH}$  bears to  $T_E$ .

At the receiving modem, the time of arrival,  $T_0$ , of the first frequency component of the guard-time  
25 waveform is determined. A sampling period, of duration  $T_E$ , is initiated a time  $T_0 + T_{PH}$ .

Accordingly, the entire symbol on each carrier frequency is sampled and intersymbol interference is eliminated.

30 According to a still further aspect of the invention, allocation of control to the transmission link between modems A and B is accomplished by setting limits to the number of packets that each modem may transmit during one transmission cycle. A packet of  
35 information comprises the data encoded on the ensemble of carriers comprising one waveform. Each modem is also constrained to transmit a minimum number of packets to maintain the communication link between the modems.

Thus, even if one modem has no data to transmit, the minimum packets maintain timing and other parameters are transmitted. On the other hand, if the volume of data for a modem is large, it is constrained to transmit only the maximum limited number of packets,  $N$ , before relinquishing control to the other modem.

In practice, if modem A has a small volume of data and modem B has a large volume of data, modem B will have control of the transmission link most of the time. If control is first allocated to modem A it will only transmit the minimal number,  $I$ , of packets. Thus A has control for only a short time. Control is then allocated to B which transmits  $N$  packets, where  $N$  may be very large. Control is again allocated to modem A which transmits  $I$  packets before returning control to B.

Thus, allocation of control is proportional to the ratio of  $I$  to  $N$ . If the transmission of the volume of data on modem A requires  $L$  packets, where  $L$  is between  $I$  and  $N$ , then the allocation is proportional to the ratio of  $L$  to  $N$ . Accordingly, allocation of the transmission link varies according to the actual needs of the user.

Additionally, the maximum number of packets,  $N$ , need not be the same for each modem, but may be varied to accommodate known disproportions in the data to be transmitted by A and B modems.

According to another aspect of the invention, signal loss and frequency offset are measured prior to data determination. A tracking system determines variations from the measured values and compensates for these deviations.

According to a further aspect of the invention, a system for determining a precise value of  $T_0$  is included. This system utilizes two timing signals, at  $f_1$  and  $f_2$ , incorporated in a waveform transmitted from modem A at time  $T_A$ . The relative phase difference

between the first and second timing signals at time  $T_A$  is zero.

The waveform is received at modem B and a rough estimate,  $T_{EST}$ , of the time of reception is obtained by detecting energy at  $f_1$ . The relative phase difference between the timing signals at time  $T_{EST}$  is utilized to obtain a precise timing reference,  $T_0$ .

#### BRIEF DESCRIPTION OF THE DRAWINGS

Fig. 1 is a graph of the ensemble of carrier frequencies utilized in the present invention.

Fig. 2 is a graph of the constellation illustrating the QAM of each carrier.

Fig. 3 is a block diagram of an embodiment of the invention.

Fig. 4 is a flow chart illustrating the synchronization process of the present invention.

Fig. 5 is a series of graphs depicting the constellations for 0, 2, 4, 5, 6 bit data elements and exemplary signal to noise ratios and power levels for each constellation.

Fig. 6 is a graph illustrating the waterfilling algorithm.

Fig. 7 is a histogram illustrating the application of the waterfilling algorithm utilized in the present invention.

Fig. 8 is a graph depicting the effects of phase dependent frequency delay on frequency components in the ensemble.

Fig. 9 is a graph depicting the wave forms utilized in the present invention to prevent intersymbol interference.

Fig. 10 is a graph depicting the method of receiving the transmitted ensemble.

Fig. 11 is a schematic diagram depicting the modulation template.

Fig. 12 is a schematic diagram depicting the quadrants of one square in the modulation template.

Fig. 13 is a schematic diagram of a hardware embodiment of the present invention.

#### DETAILED DESCRIPTION OF THE PREFERRED EMBODIMENTS

The present invention is a modem that adaptively allocates power between various carrier frequencies in a frequency ensemble to compensate for frequency dependent line noise, eliminates the need for equalization circuitry to compensate for a frequency dependent phase delay, and provides a duplex mechanism that accounts for varying channel load conditions to allocate the channel between the send and receive modems. Additional features of the invention are described below.

A brief description of the frequency ensemble and modulation scheme utilized in the present invention is first presented with respect to Figs. 1 and 2 to facilitate the understanding of the invention. A specific embodiment of the invention is then described with reference to Fig. 3. Finally, the operation of various features of the invention are described with reference to Figs. 4 through 13.

#### Modulation and Ensemble Configuration

Referring now to Fig. 1, a diagrammatic representation is shown of the transmit ensemble of the present invention. The ensemble includes 512 carrier frequencies 12 equally spaced across the available 4 kHz VF band. The present invention utilizes quadrature amplitude modulation (QAM) wherein phase independent sine and cosine signals at each carrier frequency are transmitted. The digital information transmitted at a given carrier frequency is encoded by amplitude modulating the independent sine and cosine signals at that frequency.

The QAM system transmits data at an overall bit rate,  $R_B$ . However, the transmission rate on each carrier, denoted the symbol or baud rate,  $R_S$ , is only a  
5 fraction of  $R_B$ . For example, if data were allocated equally between two carriers then  $R_S = R_B/2$ .

In the preferred embodiment 0, 2, 4, 5 or 6 bit data elements are encoded on each carrier and the modulation of each carrier is changed every 136 msec.  
10 A theoretical maximum,  $R_B$ , assuming a 6 bit  $R_S$  for each carrier, of 22,580 bit/sec (bps) results. A typical reliable  $R_S$ , assuming 4 bit  $R_S$  over 75% of the carriers, is equal to about 11,300 bps. This extremely high  $R_S$  is achieved with a bit error rate of less than  
15 1 error/100,000 bits transmitted.

In Fig. 1, a plurality of vertical lines 14 separates each ensemble into time increments known hereafter as "epochs." The epoch is of duration  $T_E$  where the magnitude of  $T_E$  is determined as set forth  
20 below.

The QAM system for encoding digital data onto the various carrier frequencies will now be described with reference to Fig. 2. In Fig. 2 a four bit "constellation" 20 for the nth carrier is depicted. A four  
25 bit number may assume sixteen discrete values. Each point in the constellation represents a vector  $(x_n, y_n)$  with  $x_n$  being the amplitude of the sine signal and  $y_n$  being the amplitude of the cosine signal in the above-described QAM system. The subscript n indicates the  
30 carrier being modulated. Accordingly, the four bit constellation requires four discrete  $y_n$  and four discrete  $x_n$  values. As described more fully below, increased power is required to increase the number of bits transmitted at a given carrier frequency due to  
35 the equivalent noise component at that frequency. The receive modem, in the case of four bit transmission, must be able to discriminate between four possible values of the  $x_n$  and  $y_n$  amplitude coefficients. This

ability to discriminate is dependent on the signal to noise ratio for a given carrier frequency.

In a preferred embodiment, packet technology  
5 is utilized to reduce the error rate. A packet includes the modulated epoch of carriers and error detection data. Each packet in error is retransmitted until correct. Alternatively, in systems where retransmission of data is undesirable, epochs with forward error correcting  
10 codes may be utilized.

#### Block Diagram

Fig. 3 is a block diagram of an embodiment of the present invention. The description that follows is of an originate modem 26 coupled to an originate end of  
15 a communication link formed over a public switched telephone line. It is understood that a communication system also includes an answer modem coupled to the answer end of the communication link. In the following discussion, parts in the answer modem corresponding to  
20 identical or similar parts in the originate modem will be designated by the reference number of the originate modem primed.

Referring now to Fig. 3, an incoming data stream is received by a send system 28 of the modem 26  
25 at data input 30. The data is stored as a sequence of data bits in a buffer memory 32. The output of buffer memory 32 is coupled to the input of a modulation parameter generator 34. The output of the modulation parameter generator 34 is coupled to a vector table  
30 buffer memory 36 with the vector table buffer memory 36 also coupled to the input of a modulator 40. The output of the modulator 40 is coupled to a time sequence buffer 42 with the time sequence buffer 42 also coupled to the input of a digital-to-analog converter 43 in-  
35 cluded in an analog I/O interface 44. The interface 44 couples the output of the modem to the public switched telephone lines 48.

A receive system 50 includes an analog-to-digital converter (ADC) 52 coupled to the public switched telephone line 48 and included in the interface 44. The  
5 output from the ADC 52 is coupled to a receive time series buffer 54 which is also coupled to the input of a demodulator 56. The output of the demodulator 56 is coupled to a receive vector table buffer 58 which is also coupled to the input of a digital data generator  
10 60. The digital data generator 60 has an output coupled to a receive data bit buffer 62 which is also coupled to an output terminal 64.

A control and scheduling unit 66 is coupled with the modulation parameter generator 34, the vector  
15 table buffer 36, the demodulator 56, and the receive vector table buffer 58.

An overview of the functioning of the embodiment depicted in Fig. 3 will now be presented. Prior to the transmission of data, the originate modem 26, in  
20 cooperation with the answer modem 26', measures the equivalent noise level at each carrier frequency, determines the number of bits per epoch to be transmitted on each carrier frequency, and allocates power to each carrier frequency as described more fully below.

25 The incoming data is received at input port 30 and formatted into a bit sequence stored in the input buffer 32.

The modulator 34 encodes a given number of bits into an  $(x_n, Y_n)$  vector for each carrier frequency  
30 utilizing the QAM system described above. For example, if it were determined that four bits were to be transmitted at frequency  $f_n$  then four bits from the bit stream would be converted to one of the sixteen points in the four bit constellation of Fig. 2. Each of these  
35 constellation points corresponds to one of sixteen possible combinations of four bits. The amplitudes of the sine and cosine signals for frequency  $n$  then corresponds to the point in the constellation encoding the four bits



of the bit sequence. The  $(x_n, y_n)$  vectors are then stored in the vector buffer table 36. The modulator receives the table of  $(x_n, y_n)$  vectors for the carriers in the ensemble and generates a digitally encoded time series representing a wave form comprising the ensemble of QAM carrier frequencies.

In a preferred embodiment the modulator 40 includes a fast Fourier transform (FFT) and performs an inverse FFT operation utilizing the  $(x, y)$  vectors as the FFT coefficients. The vector table includes 1,024 independent points representing the 1,024 FFT points of the 512 frequency constellation. The inverse FFT operation generates 1,024 points in a time series representing the QAM ensemble. The 1,024 elements of this digitally encoded time series are stored in the digital time series buffer 42. The digital time sequence is converted to an analog wave form by the analog to digital converter 43 and the interface 46 conditions the signal for transmission over the public switched telephone lines 48.

Turning now to the receive system 50, the received analog waveform from the public switched telephone lines 48 is conditioned by the interface 46 and directed to the analog to digital converter 52. The analog to digital converter 52 converts the analog waveform to a digital 1,024 entry time series table which is stored in the receive time series buffer 54. The demodulator 56 converts the 1,024 entry time series table into a 512 entry  $(x_n, y_n)$  vector table stored in the receive vector table buffer 58. This conversion is accomplished by performing an FFT on the time series. Note that information regarding the number of bits encoded onto each frequency carrier has been previously stored in the demodulator and digital data generator 60 so that the  $(x, y)$  table stored in the receive vector table buffer 58 may be transformed to an output data bit sequence by the digital data generator 60. For

example, if the  $(x_n, y_n)$  vector represents a four bit sequence then this vector would be converted to a four bit sequence and stored in the receive data bit buffer  
5 62 by the digital data generator 60. The receive data bit sequence is then directed to the output 64 as an output data stream.

A full description of the FFT techniques utilized is described in a book by Rabiner et al., entitled  
10 Theory and Applications of Digital Signal Processing, Prentice-Hall, Inc., N.J., 1975. However, the FFT modulation technique described above is not an integral part of the present invention. Alternatively, modulation could be accomplished by direct multiplication of the  
15 carrier tones as described in the above-referenced Baran patent, which is hereby incorporated by reference, at col. 10, lines 13-70, and col. 11, lines 1-30. Additionally, the demodulation system described in Baran at col. 12, lines 35-70, col. 13, lines 1-70, and col. 14, lines  
20 1-13 could be substituted.

The control and scheduling unit 66 maintains overall supervision of the sequence of operations and controls input and output functions.

#### Determination of Equivalent Noise

25 As described above, the information content of the data element encoded on each frequency carrier and the power allocated to that frequency carrier depends on the magnitude of the channel noise component at that carrier frequency. The equivalent transmitted  
30 noise component at frequency  $f_n$ ,  $N(f_n)$ , is the measured (received) noise power at frequency  $f_n$  multiplied by the measured signal loss at frequency  $f_n$ . The equivalent noise varies from line to line and also varies on a given line at different times. Accordingly, in the  
35 present system,  $N(f)$  is measured immediately prior to data transmission.

The steps of a synchronization technique utilized in the present system to measure  $N(f)$  and

establish a transmission link between answer and originate modems 26 and 26' are illustrated in Fig. 4.

Referring now to Fig. 4, in step 1 the originate modem

5 dials the number of the answer modem and the answer modem goes off hook. In step 2 the answer modem transmits an epoch of two frequencies at the following power levels:

(a) 1437.5 Hz. at -3 dBR; and

10 (b) 1687.5 Hz at -3 dBR.

The power is measured relative to a reference, R, where, in a preferred embodiment, 0dBR = -9dBm, m being a millivolt. These tones are used to determine timing and frequency offset as detailed subsequently.

15 The answer modem then transmits an answer comb containing all 512 frequencies at -27dBR. The originate modem receives the answer comb and performs an FFT on the comb. Since the power levels of the 512 frequencies were set at specified values, the control and scheduling unit  
20 66 answer modem 26 compares the  $(x_n, y_n)$  values for each frequency of the received code and compares those values to a table of  $(x_n, y_n)$  values representing the power levels of the transmitted answer code. This comparison yields the signal loss at each frequency due to the  
25 transmission over the VF telephone lines.

During step 3 both the originate and answer modems 26 and 26' accumulate noise data present on the line in the absence of any transmission by either modem. Both modems then perform an FFT on the accumulated noise signals to determine the measured  
30 (received) noise spectrum component values at each carrier frequency. Several epochs of noise may be averaged to refine the measurement.

In step 4 the originate modem transmits an  
35 epoch of two frequencies followed by an originate comb of 512 frequencies with the same power levels described above for step 2. The answer modem receives the epoch and the originate comb and calculates the timing, fre-

quency offset and signal loss values at each carrier frequency as described above for the originate modem in step 2. At this point the originate modem 26 has accumulated noise and signal loss data for transmission in the answer originate direction while the answer modem has accumulated the same data relating to transmission in the originate answer direction. Each modem requires data relating to transmission loss and receive noise in both the originate-answer and answer-originate directions. Therefore, this data is exchanged between the two modems according to the remaining steps of the synchronization process.

In step 5 the originate modem generates and transmits a first phase encoded signal indicating which carrier frequencies will support two bit transmission at standard power levels in the answer-originate direction. Each component that will support two bits in the answer-originate direction at a standard power level is generated as a -28 dBR signal with 180° relative phase. Each component that will not support two bit transmission in the answer-originate direction at the standard power level is coded as a -28 dBR, 0° relative phase signal. The answer modem receives this signal and determines which frequency carriers will support two bit transmission in the answer-originate direction.

In step 6 the answer modem generates and transmits a second phase encoded signal indicating which carrier frequencies will support two bit transmission in both the originate-answer and answer-originate directions. The generation of this signal is possible because the answer modem has accumulated noise and signal loss data in the originate-answer direction and has received the same data for the answer-originate direction in the signal generated by the originate modem in step 5. In the signal generated by the originate modem, each frequency component that will support two bits in both directions is coded with 180° relative

phase and all other components are coded with 0° relative phase.

A transmission link now exists between the  
5 two modems. In general, 300 to 400 frequency components will support two bit transmission at a standard power level, thereby establishing about a 600 bit/epoch rate between the two modems. In step 7 the originate modem sends data on the number of bits (0 to 15) and  
10 the power levels (0 to 63dB) that can be supported on each frequency in the answer-originate direction in ensemble packets formed over this existing data link. Accordingly, both the originate and answer modem now have the data relating to transmission in the answer-originate direction. The steps for calculating the  
15 number of bits and power levels that can be supported on each frequency component will be described below.

In step 8 the answer modem sends data on the number of bits and power levels that can be supported  
20 on each frequency in the originate-answer direction utilizing the existing data link. Thus, both modems are apprised of the number of bits and power levels to be supported on each frequency component in both the answer-originate and originate-answer directions.

25 The above description of the determination of the equivalent noise level component at each carrier frequency sets forth the required steps in a given sequence. However, the sequence of steps is not critical and many of the steps may be done simultaneously or  
30 in different order, for example, the performance of the FFT on the originate code and the accumulation of noise data may be done simultaneously. A precise timing reference is also calculated during the synchronization process. The calculation of this timing reference will  
35 be described more fully below after the description of the method for calculating the number of bits and power levels allocated to each frequency component.

It is a common VF telephone line impairment that a frequency offset, of up to 7 Hz, exists between transmitted and received signals. This offset must be corrected for the FFT to function reliably. In a preferred embodiment, this correction is achieved by performing a single sideband modulation of the quadrature tones at the offset frequency by the true and Hilbert images of received signal. Synchronization and tracking algorithms generate estimates of the frequency offset necessary.

#### Power and Code Complexity Allocation

The information encoded on each carrier frequency signal is decoded at the receiver channel by the demodulator 56. Channel noise distorts the transmitted signal and degrades the accuracy of the demodulation process. The transmission of a data element having a specified complexity, e.g.,  $B_0$  bits at a specified frequency,  $f_0$ , over a VF telephone line characterized by an equivalent noise level component,  $N_0$ , will now be analyzed. Generally, external system requirements determine a maximum bit error rate (BER) that can be tolerated. For the transmission of  $b_0$  bits at noise level  $N_0$  and frequency  $f_0$ , the signal to noise ratio must exceed  $E_b/N_0$  where  $E_b$  is the signal power per bit to maintain the BER below a given BER,  $(BER)_0$ .

Fig. 5 depicts the QAM constellations for signals of various complexities  $B$ . An exemplary signal to noise ratio,  $E_b/N_0$ , for each constellation and the power required to transmit the number of bits in the constellation without exceeding  $(BER)_0$  is depicted alongside each constellation graph.

A modem operates under the constraint that the total available power placed on the public switched telephone lines may not exceed a value,  $P_0$ , set by the telephone companies and government agencies. Thus, signal power may not be increased indefinitely to compensate for line noise. Accordingly, as noise

increases, the complexity of the signals transmitted must be decreased to maintain the required BER.

Most existing modems arbitrarily gear shift  
5 the signal complexity down as line noise power  
increases. For example, one prior art modem reduces  
the transmitted data rate from a maximum of 9,600 bps  
to steps of 7,200 bps, 4,800 bps, 2,400 bps, 1,200 bps,  
and so on until the bit error rate is reduced below a  
10 specified maximum. Accordingly, the signal rate is  
decreased in large steps to compensate for noise. In  
the Baran patent, the method for reducing the trans-  
mission rate takes into account the frequency dependent  
nature of the noise spectrum. There, each channel  
15 carries a preset number of bits at a specified power  
level. The noise component at each frequency is  
measured and a decision is made whether to transmit at  
each carrier frequency. Thus, in Baran, the data rate  
reduction scheme compensates for the actual distribu-  
20 tion of the noise over the available bandwidth.

In the present invention, the complexity of  
the signal on each frequency carrier and the amount of  
the available power allocated to each frequency carrier  
is varied in response to the frequency dependence of  
25 the line noise spectrum.

The present system for assigning various code  
complexities and power levels to the frequency component  
signals in the ensemble is based on the waterfilling  
algorithm. The waterfilling algorithm is an informa-  
30 tion theoretic way of assigning power to a channel to  
maximize the flow of information across the channel.  
The channel is of the type characterized by an uneven  
noise distribution and the transmitter is subject to a  
power constraint. Fig. 6 provides a visualization of  
35 the waterfilling algorithm. Referring now to Fig. 6,  
power is measured along the vertical axis and frequency  
is measured along the horizontal axis. The equivalent  
noise spectrum is represented by the solid line 70 and

the available power is represented by the area of the cross hatched region 72. The name waterfilling comes from the analogy of the equivalent noise function to a series of valleys in a mountain filled with a volume of water representing the assigned power. The water fills the valleys and assumes a level surface. A theoretical description of the waterfilling algorithm is given in the book by Gallagher, entitled Information Theory And Reliable Communication; J. Wiley and Sons, New York, 1968, p. 387.

It must be emphasized that the waterfilling theorem relates to maximizing the theoretical capacity of a channel where the capacity is defined as the maximum of all data rates achievable using different codes, all of which are error correcting, and where the best tend to be of infinite length.

The method utilizing the present invention does not maximize the capacity of the channel. Instead, the method maximizes the amount of information transmitted utilizing the QAM ensemble described above with respect to Fig. 1 and subject to an available power restriction.

An implementation of the waterfilling concept is to allocate an increment of available power to the carrier having the lowest equivalent noise floor until the allocated power level reaches the equivalent noise level of the second lowest carrier. This allocation requires a scan through the 512 frequencies.

Incremental power is then allocated between the lowest two carriers until the equivalent noise level of the third lowest channel is reached. This allocation level requires many scans through the frequency table and is computationally complex.

The power allocation method used in a preferred embodiment of the present invention is as follows:



(1) Calculate the system noise at the transmitter by measuring the equivalent noise at the receiver and multiplying by transmission loss. This process for measuring these quantities was described above with respect to synchronization and Fig. 4. The system noise components are calculated for each carrier frequency.

(2) For each carrier frequency, calculate the power levels required to transmit data elements of varying complexity (in the present case, 0, 2, 4, 5, 6, and 8 bits). This is accomplished by multiplying the equivalent noise by the signal to noise ratios necessary for transmission of the various data elements with a required BER, for example one error per 100,000 bits. The overall BER is the sum of the signal error rates of each modulated carrier. These signal to noise ratios are available from standard references, and are well-known in the art.

(3) From the calculated required transmission power levels, the marginal required power levels to increase data element complexity are determined. These marginal required power levels are the difference in transmission power divided by the quantitative difference in complexity of the data elements closest in complexity.

(4) For each channel generate a two column table of marginal required power levels and quantitative differences where the units are typically expressed as Watts and bits, respectively.

(5) Construct a histogram by organizing the table of step 4 according to increasing marginal power.

(6) Assign the available transmitter power sequentially over the increasing marginal powers until available power is exhausted.

The power allocation method may be better understood through a simple example. The numbers pre-

sented in the example are not intended to represent parameters encountered in an operating system.

Table 1 sets out the power requirement, P, to transmit a data element of a selected number of bits, N<sub>1</sub>, for two carriers A and B at frequencies f<sub>A</sub> and f<sub>B</sub>.

TABLE 1  
Carrier A

	N <sub>1</sub>	N <sub>2</sub> -N <sub>1</sub>	P	MP(N <sub>1</sub> to N <sub>2</sub> )
10	0	-	0	-
	2	2	4	MP(0to2)=2/bit
	4	2	12	MP(2to4)=4/bit
	5	1	19	MP(4to5)=7/bit
	6	1	29	MP(5to6)=10/bit

Carrier B

	N <sub>1</sub>	N <sub>2</sub> -N <sub>1</sub>	P	MP(N <sub>1</sub> to N <sub>2</sub> )
15	0	-	0	-
	2	2	6	MP(0to2)=3/bit
	4	2	18	MP(2to4)=6/bit
20	5	1	29	MP(4to5)=11/bit
	6	1	44	MP(5to6)=15/bit

The marginal power to increase the complexity from a first number of bits, N<sub>1</sub>, to a second number of bits, N<sub>2</sub>, is defined by the relationship:

$$25 \quad MP(N_1 \text{ to } N_2) = \frac{P_2 - P_1}{N_2 - N_1}$$

where P<sub>2</sub> and P<sub>1</sub> are the powers required to transmit data elements of complexity N<sub>2</sub> and N<sub>1</sub>. N<sub>2</sub>-N<sub>1</sub> is quantitative difference in the complexity of the data elements. It is understood the BER is constrained to remain below a preset limit.

The marginal powers for  $f_A$  are less than for  $f_B$  because the equivalent noise at  $f_B$ ,  $N(f_B)$ , is greater than the equivalent noise at  $f_A$ ,  $N(f_A)$ .

5           The implementation of the allocation scheme for carriers A and B will now be described. Assume that a total number of bits,  $N_T$ , are encoded on the ensemble but that no bits have been assigned to carriers A or B. For example,  $N(f_A)$  and  $N(f_A)$  might be greater than the  
10 powers of those carriers already carrying the data.

In this example, the system is to allocate ten remaining available power units between carriers A and B to increase the overall data element complexity by the maximum amount.

15           To increase  $N_T$  by two bits requires that four units of power be allocated if channel A is utilized and that six units of power be allocated in channel B is utilized. This follows because for both channels  $N_1 = 0$  and  $N_2 = 2$  and  $MP(0 \text{ to } 2) = 2/\text{bit}$  for channel A  
20 and  $MP(0 \text{ to } 2) = 3/\text{bit}$  for channel B. Therefore, the system allocates four units of power to carrier A, encodes a two bit data element on carrier A, increases the overall signal complexity from  $N_T$  to  $N_T + 2$ , and has six remaining available power units.

25           The next increase of two bits requires six power units because  $MP(2 \text{ to } 4) = 4/\text{bit}$  for carrier A and  $MP(0 \text{ to } 2) = 3/\text{bit}$  for channel B. Therefore, the system allocates six units of power to carrier B, encodes a two bit data element on carrier B, increases the over-  
30 all signal complexity from  $N_T + 2$  to  $N_T + 4$  bits, and has no remaining available power units.

As is now clear, the system "shops" among the various carrier frequencies for the lowest power cost to increase the complexity of the overall ensemble data  
35 element.

The allocation system is extended to the full 512 carrier ensemble by first generating the tables of

Table 1 for each carrier during a first pass through the frequencies.

A histogram organizing the calculated marginal required power levels for all the carriers according to increasing power is then constructed. Fig. 7 is a depiction of an exemplary histogram constructed according to the present method.

In Fig. 7 the entire table of marginal powers is not displayed. Instead, the histogram is constructed having a range of 64dB with counts spaced in 0.5dB steps. The quantitative differences between the steps are utilized as counts. Although this approach results in a slight round-off error, a significant reduction in task length is achieved. The method used to construct the histogram is not critical to practicing the invention.

Each count of the histogram has an integer entry representing the number of carriers having a marginal power value equal to the power value at the count. The histogram is scanned from the lowest power level. The integer entry at each count is multiplied by the number of counts and subtracted from the available power. The scan continues until available power is exhausted.

When the scan is completed it has been determined that all marginal power values below a given level,  $MP(max)$ , are acceptable for power and data allocation. Additionally, if available power is exhausted partially through marginal power level,  $MP(max)$ , then  $k$  additional carriers will be allocated power equal to  $MP(max + 1)$ .

The system then scans through the ensemble again to allocate power and data to the various carriers. The amount of power allocated to each carrier is the sum of marginal power values for that carrier less than or equal to  $MP(max)$ . Additionally, an amount of power equal to  $MP(max + 1)$  will be allocated if the

k MP(max + 1) values have not been previously allocated.

Timing and Phase Delay Compensation

5           The reconstruction of (x,y) vector table by the receive system requires 1024 time samples of the received waveform. The bandwidth is about 4kHz so that Nyquist sampling rate about 8000/sec and the time sample offset between samples is 125 microseconds. The total  
10 sampling time is thus 128 msec. Similarly, the transmit FFT generates a time series having 1024 entries and the symbol time is 128 msec.

          The sampling process requires a timing reference to initiate the sampling. This timing reference  
15 is established during synchronization by the following method:

          During the synchronization steps defined with reference to Fig. 4, the originate modem detects energy at the 1437.5 Hz frequency component (the first timing  
20 signal) in the answer comb at time  $T_{EST}$ . This time is a rough measure of the precise time that the first timing frequency component arrives at the receiver and is generally accurate to about 2 msec.

          This rough measure is refined by the following steps. The first timing signal and a second timing  
25 signal (at 1687.5 Hz) are transmitted with zero relative phase at the epoch mark.

          The originate modem compares the phases of the first and second timing signals at time  $T_{EST}$ . The  
30 250 Hz frequency difference between the first and second timing signals results in an  $11^\circ$  phase shift between the two signals for each 125 microsecond time sample offset. The first and second timing signals have low relative phase distortion (less than 250  
35 microseconds) due to their location near the center of the band. Accordingly, by comparing the phases of the two timing samples and correcting  $T_{EST}$  by the number of

time sampling offsets indicated by the phase difference, a precise timing reference,  $T_0$ , can be determined.

5 A further difficulty relating to timing the sampling process relates to frequency dependent phase delay induced by the VF line. This phase delay typically is on the order of 2 msec, or more, for VF telephone lines. Further, this phase delay is significantly worse near the edges of the 4kHz usable band.

10 Fig. 8 depicts distribution of the frequency carriers of the ensemble after undergoing frequency dependent phase delay. Referring to Fig. 8, three signals 90, 92, and 94 at frequencies  $f_0$ ,  $f_{256}$ , and  $f_{512}$  are depicted. Two symbols,  $x_i$  and  $y_i$ , of length  $T_S$  are transmitted at each frequency. Note that the duration of each symbol is not changed. However, the leading edge of the signals near the edge of the band 15 92 and 94 are delayed relative to those signals near the center of the band 94.

20 Additionally, for two sequentially transmitted epochs  $x_i$  and  $y_i$  the trailing section of the first symbol  $x_i$  on signals 92 and 96, near the outer edge of the band will overlap the leading edge of the second symbol  $y_i$  on the signal 94 near the center of the band. 25 This overlap results in intersymbol interference.

If the sampling interval is framed to sample a given time interval,  $T_S$ , then complete samples of every carrier in the ensemble will not be obtained and signals from other epochs will also be sampled.

30 Existing systems utilize phase correction (equalization) networks to correct for phase distortion and to prevent intersymbol interference.

The present invention utilizes a unique guard-time format to eliminate the need for an equalization network. This format is illustrated in Fig. 9. 35

Referring now to Fig. 9, first, second, and third transmitted symbols, represented by time series  $x_i$ ,  $y_i$ , and  $z_i$ , respectively, are depicted. The wave-

forms depicted in Fig. 3 are modulated on one of the carriers at frequency  $f$ . In this example a symbol time,  $T_S$ , of 128 msec. and a maximum phase delay,  $T_{PH}$ , of 8 msec are assumed. A guard-time waveform is formed by repeating the first 8 msec. of the symbol. The guard-time waveform defines an epoch of 136 msec. For example, in the first waveform 110,  $(X_i)$ , the time series of the symbol,  $X_0 - X_{1023}$ , is first transmitted, then the first 8 msec. of the symbol,  $X_0 - X_{63}$ , are repeated.

The sampling of the epoch is aligned with the last 128 msec. of the guard-time waveform (relative to the beginning of the guard-time epoch defined by those frequency components which arrive first).

This detection process is illustrated in Fig. 10. In Fig. 10 first and second guard-time waveforms 110 and 112 at  $f_1$ , near the center of the band, and  $f_2$ , near the edge of the band, are depicted. The frequency component at  $f_1$  is the component of the ensemble that arrives first at the receiver and the component at  $f_2$  arrives last. In Fig. 10 the second waveform 112, at  $f_2$ , arrives at the receiver at  $T_0 + T_{PH}$ , which is 8 msec. after the time,  $T_0$ , that the first waveform 110, at  $f_1$ , arrives at the receiver. The sampling period of 128 msec. is initiated at the time  $T_0 + T_{PH}$ . Thus, the entire symbol on  $f_2$ ,  $X_0 - X_{1023}$ , is sampled. The entire symbol at  $f_1$  is also sampled because the initial 8 msec. of that symbol has been retransmitted.

Also, intersymbol interference has been eliminated. The arrival of the second symbol,  $(y_i)$ , at  $f_1$  has been delayed 8 msec. by the retransmission of the first 8 msec. of  $(x_i)$ . Thus, the leading edge of the second symbol at  $f_1$ , does not overlap the trailing edge of the first symbol at  $f_2$ .

The 8 msec. guardtime reduces the usable time-bandwidth product of the system by only about 6%. This

small decrease is due to the very long duration of each symbol relative to the necessary guardtime.

#### Tracking

5           In practice, for a given carrier, the magnitudes of the  $(x,y)$  vectors extracted during the demodulation process do not fall exactly at the constellation points but are distributed over a range about each point due to noise and other factors.  
10 Accordingly, the signal is decoded utilizing a modulation template as depicted in Fig. 11.

Referring now to Fig. 11, the template is formed by a grid of squares 113 with the constellation points 114 at the centers of the squares 113.

15           In Fig. 11, the vector  $W = (x_n, y_n)$  represents the demodulated amplitudes of the sine and cosine signals at  $f_n$ .  $W$  is in the square 113 having the constellation point  $(3,3)$  centered therein. Accordingly,  $W$  is decoded as  $(3,3)$ .

20           The present invention includes a system for tracking to determine changes in transmission loss, frequency offset, and timing from the values determined during synchronization.

25           This tracking system utilizes the position of the received vectors in the squares of the demodulation template of Fig. 11. In Fig. 12, a single square is divided into four quadrants upper left, lower right, upper right, lower right, 115, 116, 117, and 118 characterized as too fast, too slow, too big, and too little,  
30 respectively. If counts in all four quadrants over time by frequency or over frequency at one time are equal or nearly equal then the system is in alignment. That is, if noise is the only impairment, then the direction of error for the decoded vector,  $W$ , should be random.

35           However, if transmission loss changes by even 0.1dB the number of too small counts will vary significantly from the number of too large counts. Similarly, a large difference between the number of too fast and



too slow counts indicates a phase rotation caused by a change in the offset frequency. Thus, the differences between the too fast, too slow, and too big, too small  
5 counts is an error characteristic that tracks variations in signal loss and offset frequency.

The present invention utilizes this error characteristic to adjust the signal loss and frequency offset determined during synchronization. For each  
10 frequency an adjustment of  $\pm .1\text{dB}$  or  $\pm 1.0^\circ$  is made depending on the error characteristic. Other divisions of the decoding region into distinct or overlapping subregions characterized as too fast, too slow, too big, and too little are preferred in some embodiments.

15 Additionally, the phase of the timing signals is tracked to allow corrections of  $T_0$ .

#### Allocation of Channel Control

The present invention further includes a unique system for allocating control of an established  
20 communication link between the originate and answer modems (hereinafter designated A and B, respectively). Each waveform comprising the encoded ensemble of frequencies forms a packet of information.

Control of the transmission link is first  
25 allocated to modem A. Modem A then determines the volume of data in its input buffer and transmits between I (a minimum) and N (a previously determined maximum) packets of data as appropriate. The predetermined number N serves as a limit and the end number of  
30 transmitted packets may be significantly less than required to empty the input buffer. On the other hand, if modem A has little or no data in its input buffer it will still transmit I packets of information to maintain communication with modem B. For example, the I packets  
35 may comprise the originate or answer comb of frequencies defined above with respect to Fig. 4 and the synchronization process.

Control of the communication link is then allocated to modem B which repeats the actions of modem A. Of course, if modem B transmits the minimum number, I, of packets it is confirming to modem A the vitality of modem B.

There is no need for the limits N on the two modems to be the same, or to restrict them from being adaptable under modem control to obtain rapid character echo or other user oriented goals.

#### Hardware Implementation

Fig. 13 is a block diagram of a hardware embodiment of the invention. Referring now to Fig. 13, an electronic digital processor 120, an analog I/O interface 44, and a digital I/O interface 122 are coupled to a common data bus 124. The analog I/O interface 44 interfaces the public switched telephone line 48 with the common data bus 124 and the digital interface 122 interfaces digital terminal equipment 126 with the common data bus 124.

The following components are utilized in a preferred embodiment of the invention. The analog I/O interface 44 is a high performance 12 bit coder-decoder (codec) and telephone line interface. The interface has access to RAM 132 and is controlled by supervisory microprocessor 128. The codec is a single chip combination of an analog to digital converter, a digital to analog converter, and several band pass filters.

The digital I/O interface 122 is a standard RS-232 serial interface to a standard twenty-five pin RS-232 type connector or a parallel interface to a personal computer bus.

The electronic digital processor 120, includes a supervisory processor 128, a general purpose mathematical processor 130, a 32K by 16 bit shared RAM subsystem 132, and a read only memory (ROM) unit 133, coupled to an address bus 135.

The supervisory microprocessor 128 is a 68000 data processor subsystem including a 10MHz 68000 processor and the 68000 program memory. The 32K by 16 bit program memory consists of several low power, high density, ROM chips included in the ROM unit 133.

The mathematical processor 130 is a 320 digital signal microprocessor system (DSP) including a 20MHz 320 processor, the 320 program memory, and an interface to the shared RAM system. Two high speed ROM chips, included in ROM unit 133, comprise the 8192 x 16 bit program memory.

The 320 system program memory includes programs for performing the modulation table look-up, FFT, demodulation, and other operations described above. The 68000 processor handles digital data streams at the input and output, performs tasking to and supervision of the 320 signal processor and associated analog I/O, and performs self and system test as appropriate.

The invention has been explained with respect to specific embodiments. Other embodiments will now be apparent to those of ordinary skill in the art.

In particular, the ensemble of carrier frequencies need not be limited as above-described. The number of carriers may be any power of 2, e.g. 1024, or some arbitrary number. Additionally, the frequencies need not be evenly spaced over the entire VF band. Further, the QAM scheme is not critical to practicing the invention. For example, AM could be utilized although the data rate,  $R_B$ , would be reduced.

Still further, the modulation template need not be comprised of squares. Arbitrarily shaped regions surrounding the constellation points may be defined. The tracking system was described where the squares in the modulation template were divided into four quadrants. However, a given parameter may be tracked by tracking the difference in the number of

counts in arbitrary regions defined about a constellation point.

Still further, a hardware embodiment including a supervisory microprocessor and a general purpose mathematical processor has been described. However, different combinations of IC chips may be utilized. For example, a dedicated FFT chip could be utilized to perform modulation and demodulation operations.

Still further, the information units utilized in the above description were bits. However, the invention is not limited to binary system.

Accordingly, it is therefore intended that the invention can be limited except as indicated by the appended claims.

WHAT IS CLAIMED IS:

1. In a high speed modem, for transmitting data over a telephone line, of the type that encodes data elements on an ensemble of carrier frequencies, a method for allocating data and power to the carrier frequencies, said method comprising the steps of:
  - determining the equivalent noise component for every carrier frequency in the ensemble;
  - determining the marginal power requirement to increase the complexity of the data element on each carrier from  $n$  information units to  $n + 1$  information units,  $n$  being an integer between 0 and  $N$ ;
  - ordering the marginal powers of all the carriers in the ensemble in order of increasing power;
  - assigning available power to the ordered marginal powers in order of increasing power;
  - determining the value,  $MP(\max)$  at which point the available power is exhausted; and
  - allocating power and data to each carrier frequency where the power allocated is equal to the sum of all the marginal powers less than or equal to  $MP(\max)$  for that carrier and the number of data units allocated is equal to the number of marginal powers for that carrier less than or equal to  $MP(\max)$ .
2. The invention of claim 1 where said step of ordering comprises the steps of:
  - providing a table of arbitrary marginal power levels; and
  - rounding the value of each determined marginal power level to one of the values of the table of arbitrary marginal power levels to decrease computational complexity.

3. The invention of claim 2 wherein the step of determining equivalent noise comprises the steps of:

- 5 providing an A and a B modem interconnected by a telephone line;  
establishing a communication link between said A and B modems;  
accumulating line noise data during a no transmission time interval at said A and B modems;  
10 transmitting at least a first ensemble of frequency carriers from said A modem to said B modem, where the amplitude of each carrier has a predetermined value;  
15 receiving said first ensemble at said B modem; measuring the amplitude of each carrier received at said B modem;  
comparing the measured amplitudes at said B modem with said predetermined amplitudes to determine  
20 signal loss, in dB, at each carrier frequency;  
determining the value of the component, in dB, at each carrier frequency of the accumulated noise; and  
adding the signal loss at each carrier frequency to the noise component at each carrier frequency  
25 to determine equivalent noise.

4. A high speed modem of the type for transmitting a signal on a VF telephone line, comprising:

- 30 means for receiving an input digital data stream and for storing said input digital data;  
means for generating a modulated ensemble of carriers to encode said input digital data, where each carrier has data elements of variable complexity encoded thereon;  
35 means for measuring the signal loss and noise loss of the VF telephone line for each carrier; and

means for varying the complexity of the data element encoded on each carrier and the amount of power allocated to each carrier to compensate for the measured  
5 signal loss and noise level.

5. A high speed modem of the type that encodes data elements on an ensemble of carriers of different frequency, said modem comprising:

10 a digital electronic processor;

a digital electronic memory;

bus means for coupling said processor and said memory;

means, associated with said digital electronic processor, for

15 determining the equivalent noise component for every carrier frequency in the ensemble;

determining the marginal power requirements to increase the complexity of the data element on each carrier from  $n$  information units to  $n + 1$  information  
20 units,  $n$  being an integer between 0 and  $N$ ;

ordering the marginal powers of all the carriers in the ensemble in order of increasing power;

assigning available power to the ordered marginal powers in order of increasing power;

25 determining the value,  $MP(\max)$  at which point the available power is exhausted; and

assigning power and data to each carrier frequency where the power assigned is equal to the sum of all the marginal powers less than or equal to  $MP(\max)$

30 for that carrier and the number of data units is equal to the number of marginal powers for that carrier less than or equal to  $MP(\max)$ .

6. In a high speed modem, for transmitting data in the form of a QAM ensemble of carrier frequen-  
35 cies on a VF telephone line, of the type that measures the magnitude of a system parameter prior to

transmission, a method for tracking deviations in the magnitude of the system parameter during the receipt of data, said method comprising the steps of:

- 5           generating QAM constellations for a plurality of carrier frequencies;  
            constructing a demodulation template for one of said plurality of carrier frequencies comprising a plurality of first regions with one of the points of  
10       said constellation positioned within each of said first regions;  
            forming a set of tracking regions where each first region has a first and second tracking region disposed therein;
- 15           demodulating said ensemble of carriers to obtain the demodulation points positioned in said set of first and second tracking regions;  
            counting the number of points disposed in said set of first tracking regions and the number of  
20       points disposed in said set of second tracking regions;  
            determining the difference in the number of counts disposed in said set of first tracking regions and disposed in said tracking regions to construct an error characteristic; and
- 25           utilizing said error characteristic to adjust the magnitude of said signal parameter during the receipt of data.

7. The invention of claim 6 wherein said step of constructing a demodulation template comprises  
30 the step of:

            constraining said first regions to be in the shape of squares having said constellation points centered therein.

8. The invention of claim 7 wherein said  
35 step of forming said tracking regions comprises the step of:



dividing said squares into quadrants; and  
selecting said tracking regions to be symmetri-  
cally disposed quadrants.

- 5                   9. In a communication system of the type  
including two modems (A and B) coupled by a transmis-  
sion link, each modem having an input buffer for storing  
data to be transmitted, a method for allocating control  
of the transmission link between modem A and B compris-  
10 ing the steps of:
- allocating control of the transmission  
link to modem A;
  - determining the volume of data stored in  
the input buffer of modem A;
  - 15 determining the number,  $K$ , of packets of  
data required to transmit the volume of data stored in  
the input buffer of modem A;
  - transmitting  $L$  packets of data from modem  
A to modem B where  $L$  is equal to  $I_A$  if  $K$  is less than  
20  $I_A$ , where  $L$  is equal to  $K$  if  $K$  is greater than or equal  
to  $I_A$ , and where  $L$  is equal to  $N_A$  if  $K$  is greater than  
 $N_A$  so that the minimum number of packets transmitted is  
 $I_A$  and the maximum is  $N_A$ ;
  - allocating control of the transmission  
25 link to modem B;
  - determining the volume of data in the  
input buffer of modem B;
  - determining the number,  $J$ , of packets of  
data required to transmit the volume of data stored in  
30 the input buffer of modem B;
  - transmitting  $M$  packets of data from modem  
B to modem A where  $M$  is equal to  $I_B$  if  $J$  is less than  
 $I_B$ , where  $M$  is equal to  $J$  if  $J$  is greater than or equal  
to  $I_B$ , and where  $L$  is equal to  $N_B$  if  $J$  is greater than  
35  $N_B$  so that the minimum number of packets transmitted is  
 $I_B$  and the maximum is  $N_B$ ;

where allocation of control between modem A and B is dependent on the volume of data stored in the input buffers of modems A and B.

- 5                   10. In a high speed modem, for transmitting data over a telephone line, of the type that encodes data elements on an ensemble of carrier frequencies, a system for allocating data and power to the carrier frequencies, said system comprising:
- 10                   means for determining the equivalent noise component for every carrier frequency in the ensemble;
- means for determining the marginal power requirement to increase the complexity of the data element on each carrier from  $n$  information units to  $n + 1$
- 15 information units,  $n$  being an integer between 0 and  $N$ ;
- means for ordering the marginal powers of all the carriers in the ensemble in order of increasing power;
- means for assigning available power to the
- 20 ordered marginal powers in order of increasing power;
- means for determining the value,  $MP(\max)$  at which point the available power is exhausted; and
- means allocating power and data to each carrier frequency where the power allocated is equal to
- 25 the sum of all the marginal powers less than or equal to  $MP(\max)$  for that carrier and the number of data units allocated is equal to the number of marginal powers for that carrier less than or equal to  $MP(\max)$ .
11. The invention of claim 10 where said
- 30 means for ordering comprises:
- means for providing a table of arbitrary marginal power levels; and
- means for rounding the value of each determined
- 35 marginal power level to one of the values of the table of arbitrary marginal power levels to decrease computational complexity.

12. The invention of claim 11 wherein an A and B modem are connected by a telephone line and the means for determining equivalent noise comprises:

5 means for establishing a communication link between said A and B modems;

means for accumulating line noise data during a no transmission time interval at said A and B modems;

10 means for transmitting a first ensemble of frequency carriers from said A modem to said B modem, where the amplitude of each carrier has a predetermined value;

means for receiving said first ensemble at said B modem;

15 means for measuring the amplitude of each carrier received at said B modem;

means for comparing the measured amplitudes at said B modem with said predetermined amplitudes to determine signal loss at each carrier frequency;

20 means for determining the value of the component, in dB, at each carrier frequency of the accumulated noise; and

25 means for adding the signal loss at each carrier frequency to the noise component at each carrier frequency to determine equivalent noise.

13. In a high speed modem, for transmitting data in the form of a QAM ensemble of carrier frequencies on a VF telephone line, of the type that measures the magnitude of a system parameter prior to transmission, a system for tracking deviations in the magnitude of the system parameter during the receipt of data, said system comprising:

30 means for generating QAM constellations for a plurality of carrier frequencies;

35 means for constructing a demodulation template for one of said plurality of carrier frequencies comprising a plurality of first regions with one of the

points of said constellation positioned within each of said first regions;

means for forming a set of tracking regions  
5 where each first region has a first and second tracking region disposed therein;

means for demodulating said ensemble of carriers to obtain the modulation points positioned in said set of first and second tracking regions;

10 means for counting the number of points disposed in said set of first tracking regions and the number of points disposed in said set of second tracking regions;

means for determining the difference in the  
15 number of counts disposed in said set of first tracking regions and disposed in said tracking regions to construct an error characteristic; and

means for utilizing said error characteristic to adjust the magnitude of said signal parameter during  
20 the receipt of data.

14. The invention of claim 13 wherein said means for constructing a demodulation template comprises:

means for constraining said first regions to be in the shape of squares having said constellation  
25 points centered therein.

15. The invention of claim 14 wherein said means for forming said tracking regions comprises:

means for dividing said squares into quadrants;  
and

30 means for selecting said tracking regions to be symmetrically disposed quadrants.

16. In a communication system of the type including two modems (A and B) coupled by a transmission link, each modem having an input buffer for storing  
35 data to be transmitted, a system for allocating control

of the transmission link between modem A and B comprising:

- 5 means for allocating control of the transmission link to modem A;
- means for determining the number,  $K$ , of packets of data required to transmit the volume of data stored in the input buffer of modem A;
- 10 means for transmitting  $L$  packets of data from modem A to modem B where  $L$  is equal to  $I_A$  if  $K$  is less than  $I_A$  but less than  $N_A$ , where  $L$  is equal to  $K$  if  $K$  is greater than or equal to  $I_A$ , and where  $L$  is equal to  $N_A$  if  $K$  is greater than  $N_A$  so that the minimum number of packets transmitted is  $I_A$  and the maximum is  $N_A$ ;
- 15 means for allocating control of the transmission link to modem B;
- means for determining the volume of data in the input buffer of modem B;
- 20 means for determining the number,  $J$ , of packets of data required to transmit the volume of data stored in the input buffer of modem B;
- means for transmitting  $M$  packets of data from modem B to modem A where  $M$  is equal to  $I_B$  if  $J$  is less than  $I_B$ , where  $M$  is equal to  $J$  if  $J$  is greater than or equal to  $I_B$  but less than  $N_B$ , and where  $M$  is equal to  $N_B$  if  $J$  is greater than  $N_B$  so that the minimum number of packets transmitted is  $I_B$  and the maximum is  $N_B$ ;
- 25 where allocation of control between modem A and B is dependent on the volume of data stored in the input buffers of modems A and B.
- 30

17. In a high speed modem communication system including two modems (A and B) coupled by a transmission link, each modem having an input buffer for storing data to be transmitted, each modem for transmitting
- 35 data over a telephone line and each modem of the type that encodes data elements on an ensemble of carrier frequencies, a method of operating said modems to effi-

ciently allocate power and data to the carrier frequencies, to compensate for frequency dependent phase delay, where the maximum estimated magnitude of the phase delay is  $T_{PH}$ , to prevent intersymbol interference, to allocate control of the transmission link between modem A and modem B and for initiating a sampling interval having a given time sample offset equal to the reciprocal of the sampling frequency, said method comprising:

5                   determining the equivalent noise component for every carrier frequency in the ensemble;

                  determining the marginal power requirement to increase the complexity of the data element on each carrier from  $n$  information units to  $n + 1$  information

15                   units,  $n$  being an integer between 0 and  $N$ ;

                  ordering the marginal powers of all the carriers in the ensemble in order of increasing power;

                  assigning available power to the ordered marginal powers in order of increasing power;

20                   determining the value,  $MP(max)$  at which point the available power is exhausted;

                  allocating power and data to each carrier frequency where the power allocated is equal to the sum of all the marginal powers less than or equal to  $MP(max)$

25                   for that carrier and the number of data units allocated is equal to the number of marginal powers for that carrier less than or equal to  $MP(max)$ ;

                  transmitting a symbol encoded on one of said carrier frequencies where said symbol is a predetermined

30                   time duration,  $T_S$ ;

                  retransmitting the first  $T_{PH}$  seconds of said symbol to form a transmitted waveform of duration  $T_E + T_{PH}$ ;

                  allocating control of the transmission link

35                   to modem A;

                  determining the volume of data stored in the input buffer of modem A;

- determining the number,  $K$ , of packets of data required to transmit the volume of data stored in the input buffer of modem A;
- 5           transmitting  $L$  packets of data from modem A to modem B where  $L$  is equal to  $I_A$  if  $K$  is less than  $I_A$ , where  $L$  is equal to  $K$  if  $K$  is greater than or equal to  $I_A$ , and where  $L$  is equal to  $N_A$  if  $K$  is greater than  $N_A$  so that the minimum number of packets transmitted is  $I_A$
- 10          and the maximum is  $N_A$ ;
- allocating control of the transmission link to modem B;
- determining the volume of data in the input buffer of modem B;
- 15          determining the number,  $J$ , of packets of data required to transmit the volume of data stored in the input buffer of modem B;
- transmitting  $M$  packets of data from modem B to modem A where  $M$  is equal to  $I_B$  if  $J$  is less than  $I_B$ ,
- 20          where  $M$  is equal to  $J$  if  $J$  is greater than or equal to  $I_B$ , and where  $L$  is equal to  $N_B$  if  $J$  is greater than  $N_B$  so that the minimum number of packets transmitted is  $I_B$  and the maximum is  $N_B$ ;
- where allocation of control between modem A
- 25          and B is dependent on the volume of data stored in the input buffers of modems A and B;
- generating an analog waveform at modem A including first and second frequency components at  $f_1$  and  $f_2$ ;
- 30          transmitting said waveform from modem A to modem B at time  $T_A$ ;
- adjusting the phases of said first and second frequency components so that their relative phase difference at time  $T_A$  is equal to about  $0^\circ$ ;
- 35          detecting energy at frequency  $f_1$  at modem B to determine the estimated time,  $T_{EST}$ , that said waveform arrives at modem B;

- determining the relative phase difference at modem B between said first and second frequency components at time  $T_{EST}$ ;
- 5            calculating the number of sampling time offsets,  $N_I$ , required for the relative phase of said first and second carriers to change from 0 to said relative phase difference; and
- 10           changing the magnitude of  $T_{EST}$  by  $N_I$  sampling intervals to obtain a precise timing reference,  $T_0$ .



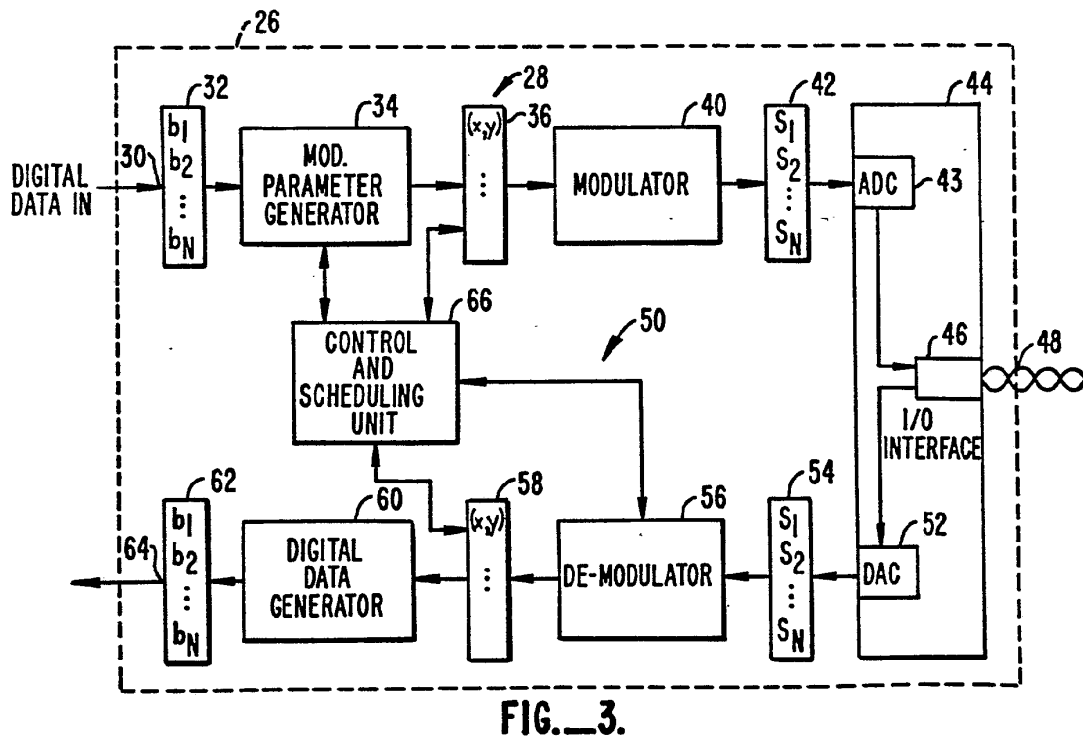
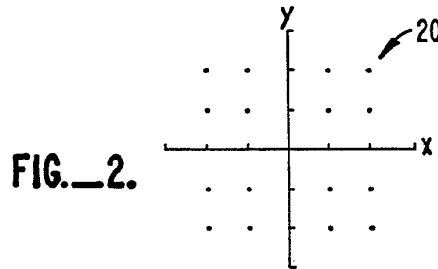
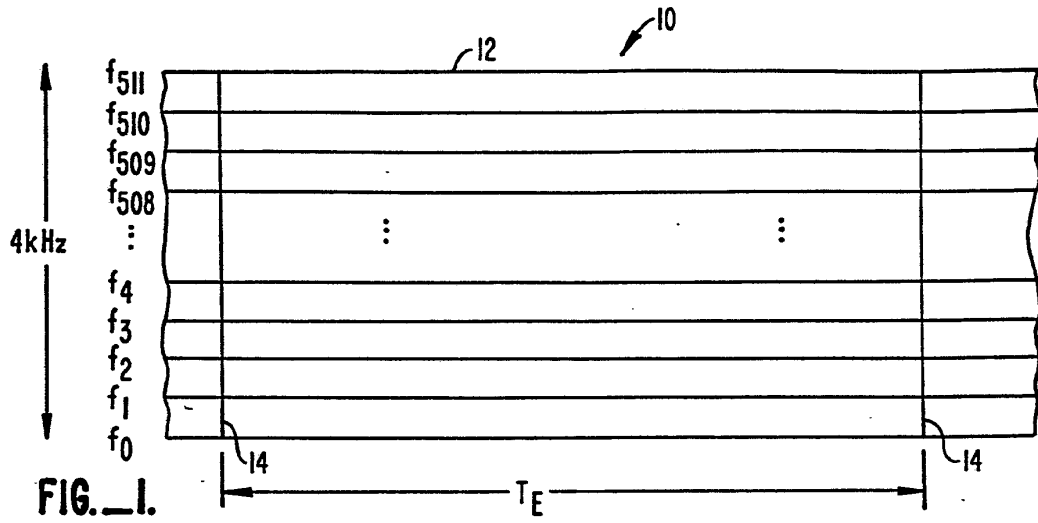

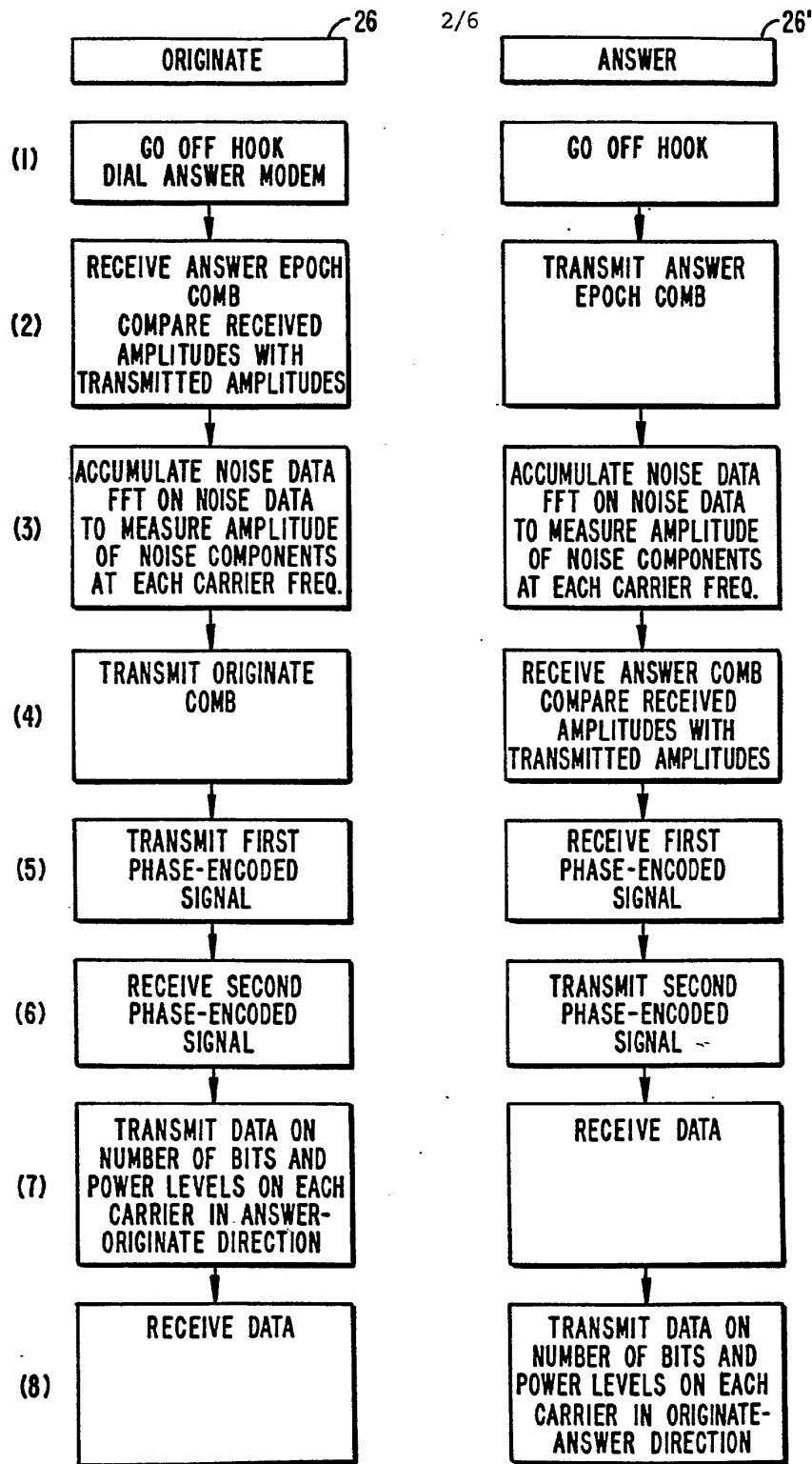

FIG. 4.

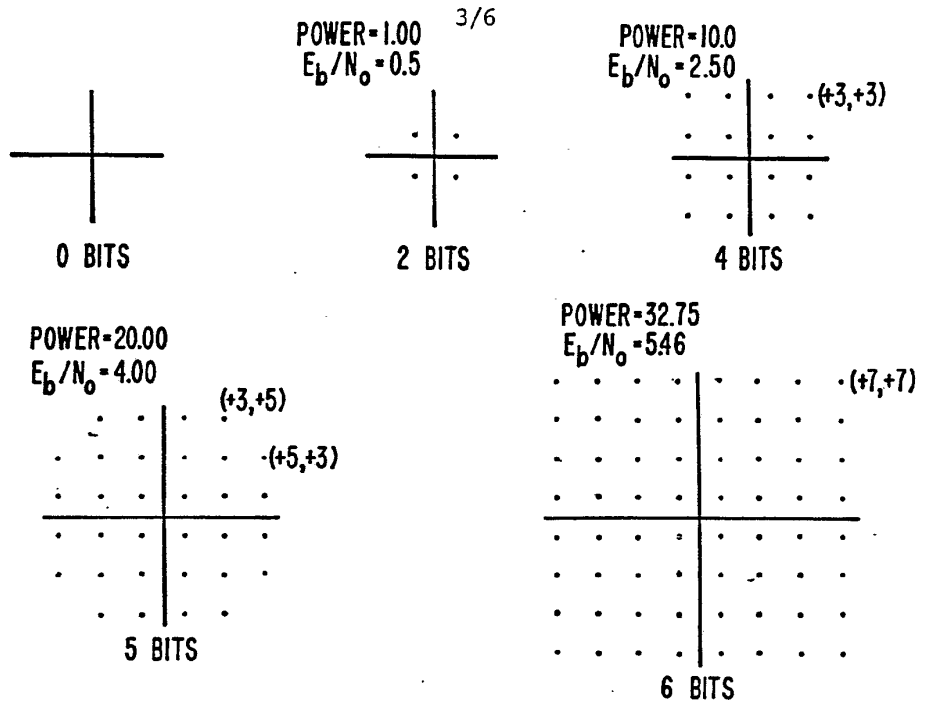

FIG. 5.

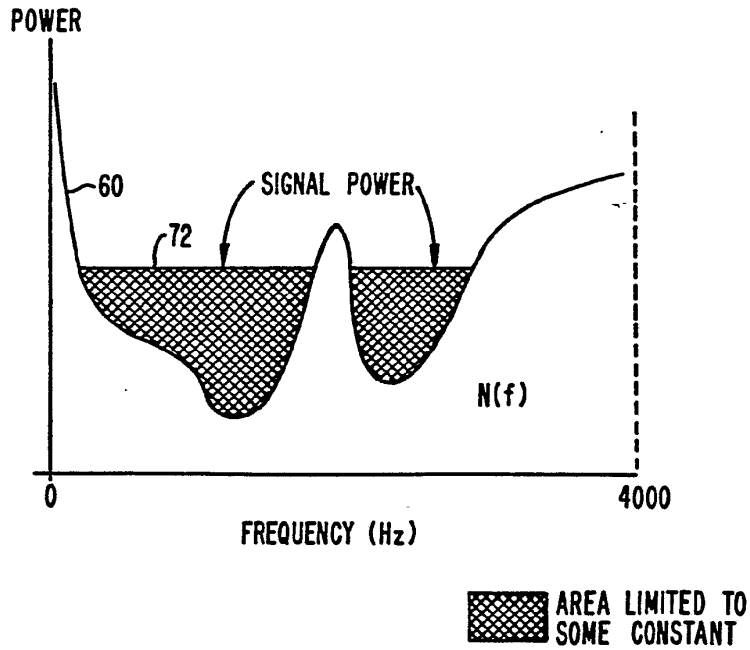

FIG. 6.

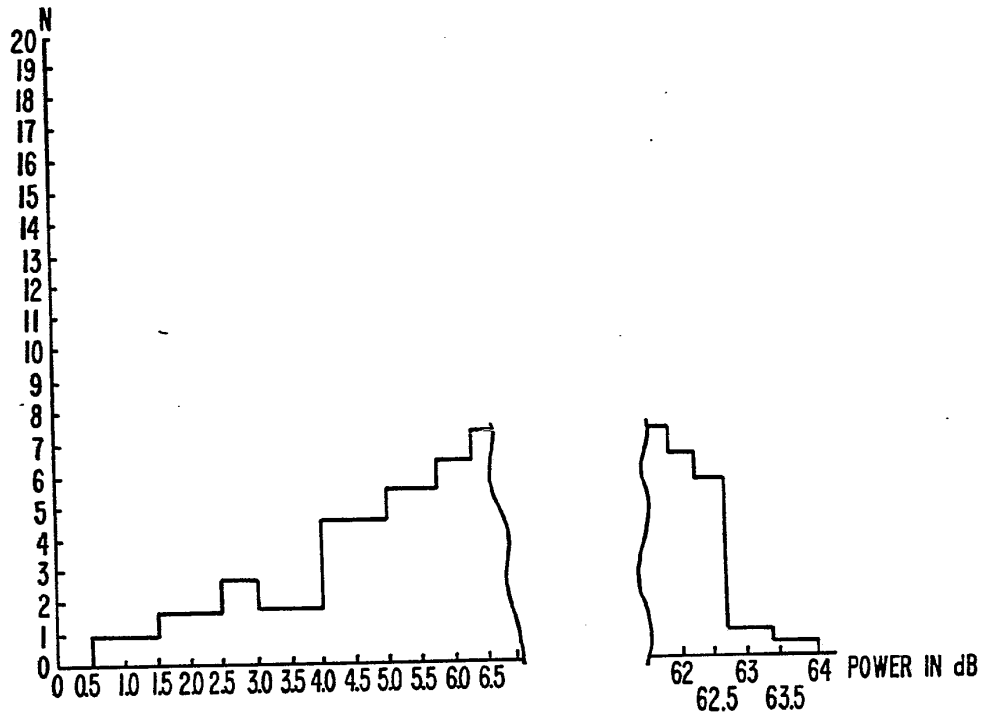

FIG. 7.

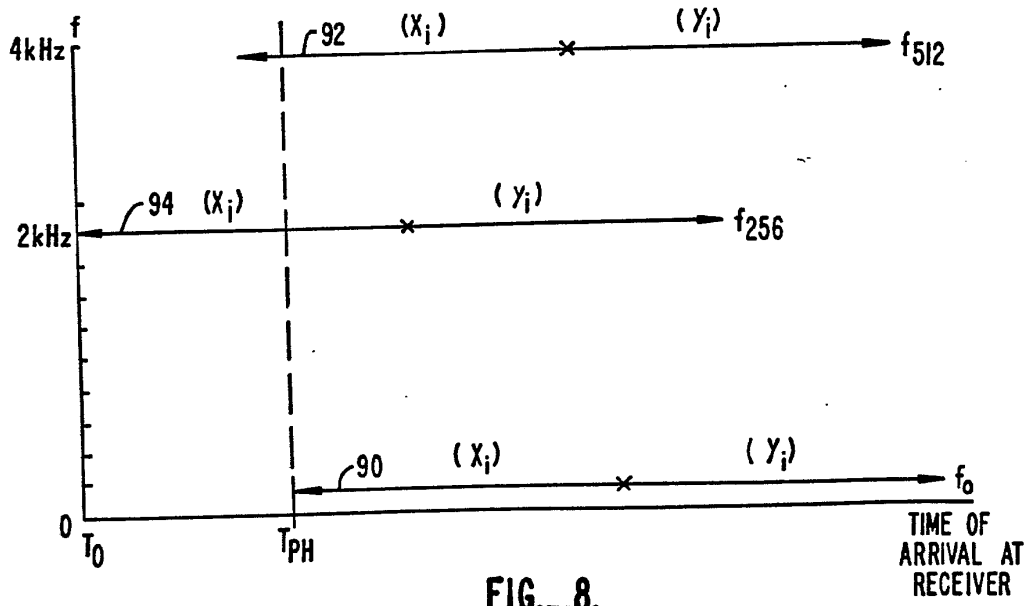

FIG. 8.

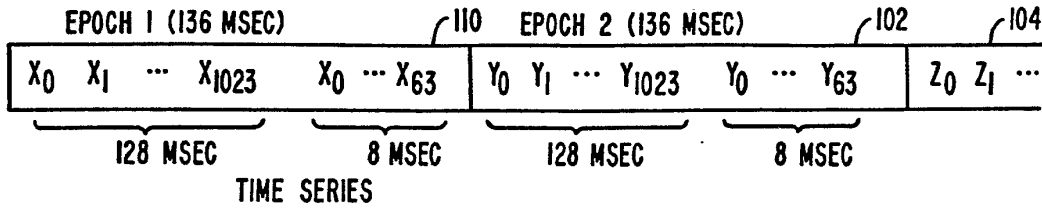

FIG. 9.

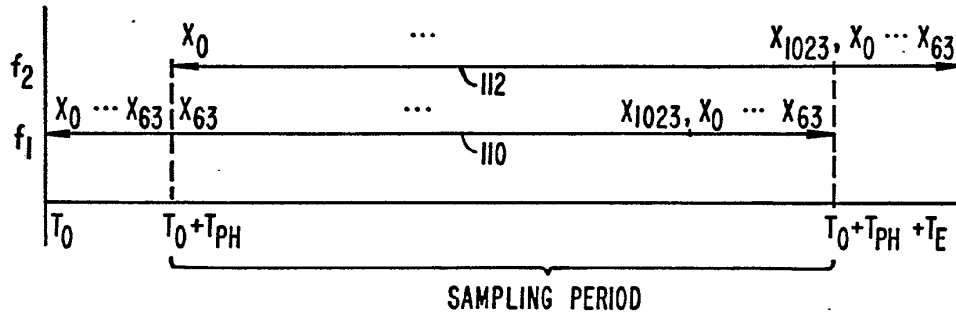

FIG. 10.

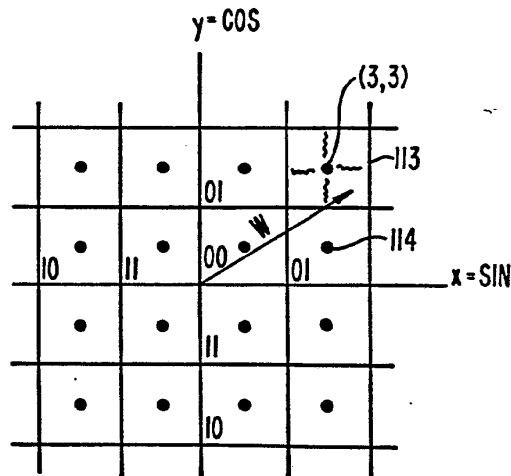

FIG. 11.

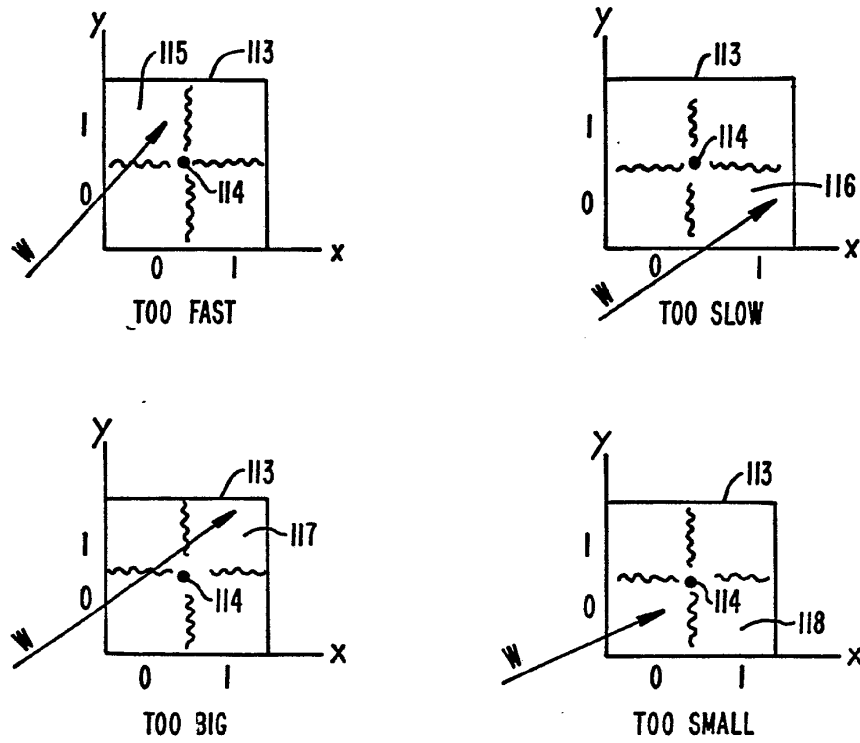

FIG. 12.

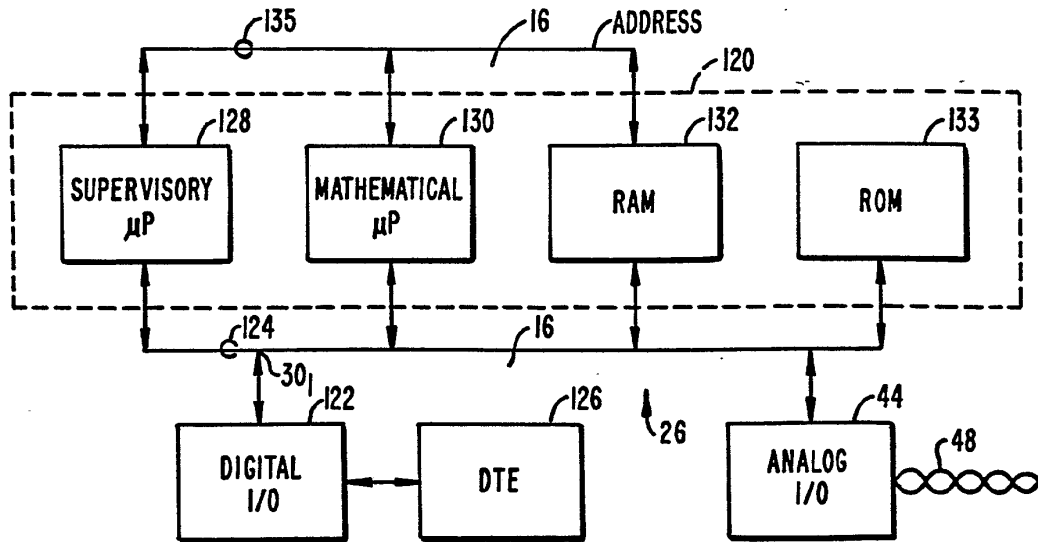



FIG. 13.

## INTERNATIONAL SEARCH REPORT

International Application No PCT/US86/00983

<b>I. CLASSIFICATION OF SUBJECT MATTER</b> (if several classification symbols apply, indicate all) <sup>3</sup>		
According to International Patent Classification (IPC) or to both National Classification and IPC <b>IPC (4): H04M 11/00; H04B 15/00, 1/10; H04L 5/00, 25/08; H04B 1/10</b> <b>U.S. Cl.: 179/2DP; 375/39, 58, 99; 455/63</b>		
<b>II. FIELDS SEARCHED</b>		
Minimum Documentation Searched <sup>4</sup>		
Classification System	Classification Symbols	
U.S.	179/2DP; 375/38, 39, 40, 58, 118; 370/16, 108; 455/63, 68+; 340/825.15	
Documentation Searched other than Minimum Documentation to the Extent that such Documents are Included in the Fields Searched <sup>5</sup>		
<b>III. DOCUMENTS CONSIDERED TO BE RELEVANT</b> <sup>14</sup>		
Category *	Citation of Document, <sup>16</sup> with indication, where appropriate, of the relevant passages <sup>17</sup>	Relevant to Claim No. <sup>18</sup>
X, P	Telecommunications, Volume 19, No. 10, issued October 1985 (Dedham, Massachusetts), H.R. Johnson, "PC Communications: The Revolution Is Coming", see pages 58j to 58r.	1-17
A	US, A, 4,438,511 (Baran) 20 March 1984	1-17
A, P	US, A, 4,559,520 (Johnston) 17 December 1985	1-17
A	US, A, 4,206,320 (Keasler et al.) 03 June 1980	1-17
A	US, A, 3,810,019 (Miller) 07 May 1974	1-5, 10-12, 17
A	US, A, 4,328,581 (Harmon et al.) 04 May 1982	1-5, 10-12, 17
A	US, A, 3,971,996 (Motley et al.) 27 July 1976	6-8, 13-15
A, P	US, A, 4,555,790 (Betts et al.) 26 November 1985	6-8, 13-15
(cont'd)		
<p>* Special categories of cited documents: <sup>15</sup></p> <p>"A" document defining the general state of the art which is not considered to be of particular relevance</p> <p>"E" earlier document but published on or after the international filing date</p> <p>"L" document which may throw doubts on priority claim(s) or which is cited to establish the publication date of another citation or other special reason (as specified)</p> <p>"O" document referring to an oral disclosure, use, exhibition or other means</p> <p>"P" document published prior to the international filing date but later than the priority date claimed</p> <p>"T" later document published after the international filing date or priority date and not in conflict with the application but cited to understand the principle or theory underlying the invention</p> <p>"X" document of particular relevance; the claimed invention cannot be considered novel or cannot be considered to involve an inventive step</p> <p>"Y" document of particular relevance; the claimed invention cannot be considered to involve an inventive step when the document is combined with one or more other such documents, such combination being obvious to a person skilled in the art.</p> <p>"&amp;" document member of the same patent family</p>		
<b>IV. CERTIFICATION</b>		
Date of the Actual Completion of the International Search <sup>2</sup>	Date of Mailing of this International Search Report <sup>2</sup>	
17 June 1986	10 JUL 1986	
International Searching Authority <sup>1</sup>	Signature of Authorized Officer <sup>20</sup>	
ISA/US	 Matthew E. Connors	

III. DOCUMENTS CONSIDERED TO BE RELEVANT (CONTINUED FROM THE SECOND SHEET)		
Category*	Citation of Document, <sup>16</sup> with indication, where appropriate, of the relevant passages <sup>17</sup>	Relevant to Claim No <sup>18</sup>
A	US, A, 3,783,385 (Dunn et al.) 01 January 1974	1-5
A	US, A, 4,047,153 (Thirion) 06 September 1977	1-5
A	US, A, 4,494,238 (Groth, Jr.) 15 January 1985	1-5
A	US, A, 4,495,619 (Acampora) 22 January 1985	1-5,10-12,17
A	US, A, 4,484,336 (Catchpole et al.) 20 November 1984	1-5,10-12,17
A	US, A, 4,459,701 (Lamiral et al.) 10 July 1984	9,16,17
A	US, A, 3,755,736 (Kaneko et al.) 28 August 1973	9,16,17
A	US, A, 4,315,319 (White) 09 February 1982	1-5,10-12,17
A,P	US, A, 4,573,133 (White) 25 February 1986	1-5,10-12,17
A	US, A, 4,392,225 (Wortman) 05 July 1983	1-5,10-12,17





INTERNATIONAL APPLICATION PUBLISHED UNDER THE PATENT COOPERATION TREATY (PCT)

<p>(51) International Patent Classification <sup>6</sup> : <b>H04L 1/24, 1/20, 5/06, 12/28, H04N 7/16, H04M 11/06, H04B 10/24</b></p>	<p>A2</p>	<p>(11) International Publication Number: <b>WO 96/24995</b> (43) International Publication Date: 15 August 1996 (15.08.96)</p>
<p>(21) International Application Number: PCT/US96/01606 (22) International Filing Date: 6 February 1996 (06.02.96) (30) Priority Data: 08/384,659 6 February 1995 (06.02.95) US 08/457,295 1 June 1995 (01.06.95) US (71) Applicant: ADC TELECOMMUNICATIONS, INC. [US/US]; 4900 West 78th Street, Bloomington, MN 55435 (US). (72) Inventors: ANDERSON, Brian, D.; 11430 - 50th Place North, Plymouth, MN 55442 (US). ROBERTS, Harold, A.; 7017 Beacon Circle, Eden Prairie, MN 55346 (US). BREDE, Jeffrey; 8073 Curtis Lane, Eden Prairie, MN 55347 (US). BUSKA, Steven, P.; 13370 Stanton Drive, Minnetonka, MN 55305 (US). (74) Agent: VIKSNINS, Ann, S.; Schwegman, Lundberg, Woessner &amp; Kluth, 3500 IDS Center, 80 South Eighth Street, P.O. Box 2938, Minneapolis, MN 55402 (US).</p>	<p>(81) Designated States: AL, AM, AT, AU, AZ, BB, BG, BR, BY, CA, CH, CN, CZ, DE, DK, EE, ES, FI, GB, GE, HU, IS, JP, KE, KG, KP, KR, KZ, LK, LR, LS, LT, LU, LV, MD, MG, MK, MN, MW, MX, NO, NZ, PL, PT, RO, RU, SD, SE, SG, SI, SK, TJ, TM, TR, TT, UA, UG, UZ, VN, ARIPO patent (KE, LS, MW, SD, SZ, UG), Eurasian patent (AZ, BY, KG, KZ, RU, TJ, TM), European patent (AT, BE, CH, DE, DK, ES, FR, GB, GR, IE, IT, LU, MC, NL, PT, SE), OAPI patent (BF, BJ, CF, CG, CI, CM, GA, GN, ML, MR, NE, SN, TD, TG).</p> <p><b>Published</b> <i>Without international search report and to be republished upon receipt of that report.</i></p>	

(54) Title: METHOD OF COMMUNICATION CHANNEL MONITORING USING PARITY BITS

(57) Abstract

A method for monitoring at least one telephony communication n-bit channel, wherein one of the bits is a parity bit, includes sampling the parity bit of the n-bit channel. A probable bit error rate is derived from the sampling of the parity bit. The probable bit error rate can be compared to a pre-determined bit error rate value to determine if the at least one telephony communication n-bit channel is corrupted. If the at least one telephony communication n-bit channel is corrupted, the at least one telephony communication n-bit channel is re-allocated to an uncorrupted and unallocated telephony communication n-bit channel. Further, at least one unallocated telephony communication channel can be periodically monitored and error data accumulated to indicate the quality thereof.

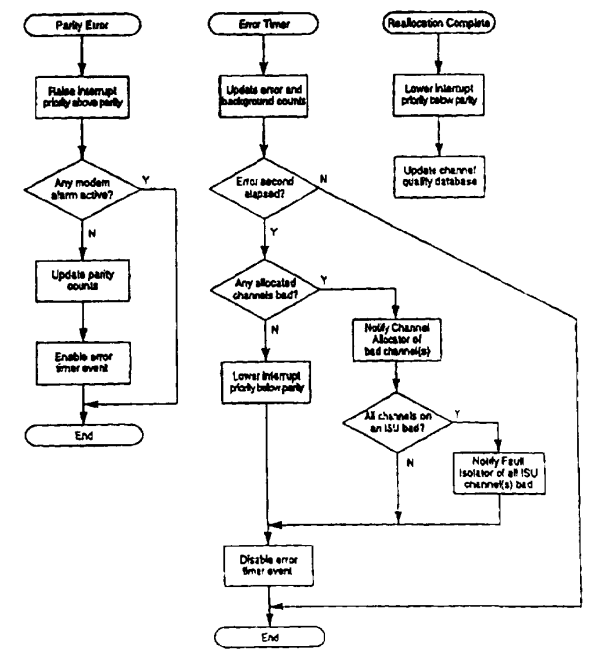

**FOR THE PURPOSES OF INFORMATION ONLY**

Codes used to identify States party to the PCT on the front pages of pamphlets publishing international applications under the PCT.

AM	Armenia	GB	United Kingdom	MW	Malawi
AT	Austria	GE	Georgia	MX	Mexico
AU	Australia	GN	Guinea	NE	Niger
BB	Barbados	GR	Greece	NL	Netherlands
BE	Belgium	HU	Hungary	NO	Norway
BF	Burkina Faso	IE	Ireland	NZ	New Zealand
BG	Bulgaria	IT	Italy	PL	Poland
BJ	Benin	JP	Japan	PT	Portugal
BR	Brazil	KE	Kenya	RO	Romania
BY	Belarus	KG	Kyrgystan	RU	Russian Federation
CA	Canada	KP	Democratic People's Republic of Korea	SD	Sudan
CF	Central African Republic	KR	Republic of Korea	SE	Sweden
CG	Congo	KZ	Kazakhstan	SG	Singapore
CH	Switzerland	LI	Liechtenstein	SI	Slovenia
CI	Côte d'Ivoire	LK	Sri Lanka	SK	Slovakia
CM	Cameroon	LR	Liberia	SN	Senegal
CN	China	LT	Lithuania	SZ	Swaziland
CS	Czechoslovakia	LU	Luxembourg	TD	Chad
CZ	Czech Republic	LV	Latvia	TG	Togo
DE	Germany	MC	Monaco	TJ	Tajikistan
DK	Denmark	MD	Republic of Moldova	TT	Trinidad and Tobago
EE	Estonia	MG	Madagascar	UA	Ukraine
ES	Spain	ML	Mali	UG	Uganda
FI	Finland	MN	Mongolia	US	United States of America
FR	France	MR	Mauritania	UZ	Uzbekistan
GA	Gabon			VN	Viet Nam

## METHOD OF COMMUNICATION CHANNEL MONITORING

### 5                                    Field of the Invention

The present invention relates generally to the field of communication systems. More particularly, the present invention relates to the monitoring of communication channels.

### Background of the Invention

10                Two information services found in households and businesses today include television, or video, services and telephone services. Another information service involves digital data transfer which is most frequently accomplished using a modem connected to a telephone service. All further references to telephony herein shall include both telephone services and digital  
15 data transfer services.

                 Characteristics of telephony and video signals are different and therefore telephony and video networks are designed differently as well. For example, telephony information occupies a relatively narrow band when compared to the bandwidth for video signals. In addition, telephony signals  
20 are low frequency whereas NTSC standard video signals are transmitted at carrier frequencies greater than 50 MHz. Accordingly, telephone transmission networks are relatively narrow band systems which operate at audio frequencies and which typically serve the customer by twisted wire drops from a curb-side junction box. On the other hand, cable television services are  
25 broad band and incorporate various frequency carrier mixing methods to achieve signals compatible with conventional very high frequency television receivers. Cable television systems or video services are typically provided by cable television companies through a shielded cable service connection to each individual home or business.

30                One attempt to combine telephony and video services into a single network is described in U.S. Patent No. 4,977,593 to Balance entitled "Optical Communications Network." Balance describes a passive optical communications network with an optical source located in a central station. The optical source transmits time division multiplexed optical signals along an

optical fiber and which signals are later split by a series of splitters between several individual fibers servicing outstations. The network allows for digital speech data to be transmitted from the outstations to the central station via the same optical path. In addition, Balance indicates that additional wavelengths  
5 could be utilized to add services, such as cable television, via digital multiplex to the network.

A 1988 NCTA technical paper, entitled "Fiber Backbone: A Proposal For an Evolutionary Cable TV network Architecture," by James A. Chiddix and David M. Pangrac, describes a hybrid optical fiber/coaxial cable television  
10 (CATV) system architecture. The architecture builds upon existing coaxial CATV networks. The architecture includes the use of a direct optical fiber path from a head end to a number of feed points in an already existing CATV distribution system.

U.S. Patent No. 5,153,763 to Pidgeon, entitled "CATV Distribution  
15 Networks Using Light Wave Transmission Lines," describes a CATV network for distribution of broad band, multichannel CATV signals from a head end to a plurality of subscribers. Electrical to optical transmitters at the head end and optical to electrical receivers at a fiber node launch and receive optical signals corresponding to broad band CATV electrical signals. Distribution  
20 from the fiber node is obtained by transmitting electrical signals along coaxial cable transmission lines. The system reduces distortion of the transmitted broad band CATV signals by block conversion of all or part of the broad band of CATV signals to a frequency range which is less than an octave. Related U.S. Patent No. 5,262,883 to Pidgeon, entitled "CATV Distribution Networks  
25 Using Light Wave Transmission Lines," further describes the distortion reducing system.

Although the above-mentioned networks describe various concepts for transmitting broad band video signals over various architectures, which may include hybrid optical fiber/coax architectures, none of these references  
30 describe a cost effective, flexible, communications system for telephony communications. Several problems are inherent in such a communication system.

One such problem is the need to optimize the bandwidth used for transporting data so that the bandwidth used does not exceed the allotted bandwidth. Bandwidth requirements are particularly critical in multi-point to point communication where multiple transmitters at remote units must be accommodated such that allotted bandwidth is not exceeded.

A second problem involves power consumption of the system. The communication system should minimize the power used at the remote units for the transport of data, as the equipment utilized at the remote units for transmission and reception may be supplied by power distributed over the transmission medium of the system.

Data integrity must also be addressed. Both internal and external interference can degrade the communication. Internal interference exists between data signals being transported over the system. That is, transported data signals over a common communication link may experience interference therebetween, decreasing the integrity of the data. Ingress from external sources can also effect the integrity of data transmissions. A telephony communication network is susceptible to "noise" generated by external sources, such as HAM radio. Because such noise can be intermittent and vary in intensity, a method of transporting data over the system should correct or avoid the presence of such ingress.

These problems and others as will become apparent from the description to follow, present a need for an enhanced communication system.

#### Summary of the Invention

The use of channel monitoring to address some of the problems inherent in a multi-point to point communication system, in particular, with respect to ingress, is described. The monitoring method of the present invention monitors a telephony communication n-bit channel wherein one of the bits is a parity bit. The parity bit of the n-bit channel is sampled and a probable bit error rate is derived from the sampling of the parity bit.

In one embodiment, the probable bit error rate over a time period is compared to a predetermined bit error rate value representing a minimum bit

error rate to determine if the n-bit channel is corrupted. A corrupted channel can then either be reallocated or, in another embodiment, the transmission power of the channel can be increased to overcome the corruption.

In an alternate method embodiment, the method comprises the steps of  
5 sampling the parity bit of the n-bit channel over a first time period, deriving a probable bit error rate from the sampling of the parity bit over the first time period, comparing the probable bit error rate over the first time period to a pre-determined bit error rate value to determine if the n-bit channel is corrupted, and accumulating a probable bit error rate over a plurality of  
10 successive time periods if the n-bit channel is not corrupted.

In another alternate method embodiment, the method comprises the steps of sampling the parity bit of the n-bit channel and deriving a probable bit error rate from the sampling of the parity bit over a first time period. The probable bit error rate over the first time period is compared to a first  
15 predetermined bit error rate value to determine if the n-bit channel is corrupted. A probable bit error rate from the sampling of the parity bit over a second time period is derived. The second time period is longer than the first time period and runs concurrently therewith. The probable bit error rate over the second time period is compared to a second predetermined bit error rate  
20 value to determine if the n-bit channel is corrupted.

In still yet another alternate embodiment, a method for monitoring at least one unallocated telephony communication channel includes periodically monitoring the at least one unallocated telephony communication channel. Error data for the at least one unallocated telephony communication channel  
25 accumulated and the at least one unallocated telephony communication channel is allocated based on the error data.

#### Brief Description of the Drawings

Figure 1 shows a block diagram of a communication system in  
30 accordance with the present invention utilizing a hybrid fiber/coax distribution network:

Figure 2 is an alternate embodiment of the system of Figure 1:

Figure 3 is a detailed block diagram of a host digital terminal (HDT) with associated transmitters and receivers of the system of Figure 1;

Figure 4 is a block diagram of the associated transmitters and receivers of Figure 3;

5 Figure 5 is a block diagram of an optical distribution node of the system of Figure 1;

Figure 6 is a general block diagram of an integrated service unit (ISU) such as a home integrated service unit (HISU) or a multiple integrated service unit (MISU) of Figure 1;

10 Figures 7A, 7B, 7C show data frame structures and frame signaling utilized in the HDT of Figure 3;

Figure 8 is a general block diagram of a coax master card (CXMC) of a coax master unit (CXMU) of Figure 3;

15 Figure 9A shows a spectral allocation for a first transport embodiment for telephony transport in the system of Figure 1;

Figure 9B shows a mapping diagram for QAM modulation;

Figure 9C shows a mapping diagram for BPSK modulation;

Figure 9D shows a subband diagram for the spectral allocation of Figure 9A;

20 Figure 10 is a block diagram of a master coax card (MCC) downstream transmission architecture of the CXMU for the first transport embodiment of the system of Figure 1;

Figure 11 is a block diagram of a coax transport unit (CXTU) downstream receiver architecture of an MISU for the first transport 25 embodiment of the system of Figure 1;

Figure 12 is a block diagram of a coax home module (CXHM) downstream receiver architecture of an HISU for the first transport embodiment of the of the system of Figure 1;

Figure 13 is a block diagram of a CXHM upstream transmission 30 architecture associated with the CXHM downstream receiver architecture of Figure 12;

Figure 14 is a block diagram of a CXTU upstream transmission

architecture associated with the CXTU downstream receiver architecture of Figure 11;

Figure 15 is a block diagram of an MCC upstream receiver architecture associated with the MCC downstream transmission architecture of Figure 10;

5 Figure 16 is a flow diagram of a acquisition distributed loop routine for use with the system of Figure 1;

Figure 17 is a flow diagram of a tracking distributed loop architecture routine for use with the system of Figure 1;

10 Figure 18 shows a magnitude response of a polyphase filter bank of the MCC upstream receiver architecture of Figure 15;

Figure 19 is an enlarged view of part of the magnitude response of Figure 18;

Figure 20 is a block diagram of a ingress filter structure and FFT of the MCC upstream receiver architecture of Figure 15;

15 Figure 21 is a block diagram of a polyphase filter structure of the ingress filter structure and FFT of Figure 20;

Figure 22A is a block diagram of a carrier, amplitude, timing recovery block of the downstream receiver architectures of the first transport embodiment;

20 Figure 22B is a block diagram of a carrier, amplitude, timing recovery block of the MCC upstream receiver architecture of the first transport embodiment;

Figure 23 is a block diagram of internal equalizer operation for the receiver architectures of the first transport embodiment;

25 Figure 24 is a spectral allocation of a second transport embodiment for transport in the system of Figure 1;

Figure 25 is a block diagram of an MCC modem architecture of the CXMU for the second transport embodiment of the system of Figure 1;

30 Figure 26 is a block diagram of a subscriber modem architecture of the HISU for the second transport embodiment of the system of Figure 1;

Figure 27 is a block diagram of a modem of the subscriber modem architecture of Figure 26:



Figure 28 is a block diagram for channel monitoring used in the system of Figure 1;

Figures 29A, 29B, and 29C are flow diagrams for error monitor portions of channel monitor routines of Figure 28;

5 Figure 29D is an alternate flow diagram for the diagram of Figure 29B;

Figure 30 is a flow diagram for a background monitor portion of the channel monitor routines of Figure 28; and

10 Figure 31 is a flow diagram for a backup portion of the channel monitor routines of Figure 28.

#### Detailed Description of the Preferred Embodiment

The communication system 10, as shown in Figure 1, of the present invention is an access platform primarily designed to deliver residential and  
15 business telecommunication services over a hybrid fiber-coaxial (HFC) distribution network 11. The system 10 is a cost-effective platform for delivery of telephony and video services. Telephony services may include standard telephony, computer data and/or telemetry. In addition, the present system is a flexible platform for accommodating existing and emerging  
20 services for residential subscribers.

The hybrid fiber-coaxial distribution network 11 utilizes optical fiber feeder lines to deliver telephony and video service to a distribution node 18 (referred to hereinafter as the optical distribution node (ODN)) remotely located from a central office or a head end 32. From the ODNs 18, service is  
25 distributed to subscribers via a coaxial network. Several advantages exist by utilizing the HFC-based communication system 10. By utilizing fiber installed in the feeder, the system 10 spreads the cost of optoelectronics across hundreds of subscribers. Instead of having a separate copper loop which runs from a distribution point to each subscriber ("star" distribution approach), the  
30 system 10 implements a bused approach where a distribution coaxial leg 30 passes each home and subscribers "tap" the distribution coaxial leg 30 for service. The system 10 also allows non-video services to be modulated for

transmission using more cost-effective RF modem devices in dedicated portions of the RF spectrum. Finally, the system 10 allows video services to be carried on existing coaxial facilities with no additional subscriber equipment because the coaxial distribution links can directly drive existing cable-ready television sets.

It should be apparent to one skilled in the art that the modem transport architecture described herein and the functionality of the architecture and operations surrounding such architecture could be utilized with distribution networks other than hybrid fiber coax networks. For example, the functionality may be performed with respect to wireless systems. Therefore, the present invention contemplates use of such systems in accordance with the accompanying claims.

The system 10 includes host digital terminals 12 (HDTs) which implement all common equipment functions for telephony transport, such as network interface, synchronization, DS0 grooming, and operations, administration, maintenance and provisioning (OAM&P) interfaces, and which include the interface between the switching network and a transport system which carries information to and from customer interface equipment such as integrated service units 100 (ISUs). Integrated services units (ISUs) 100, such as home integrated service units (HISUs) 68 or multiple user integrated service units (MISUs) 66, which may include a business integrated service unit as opposed to a multiple dwelling integrated service unit, implement all customer interface functions and interface to the transport system which carries information to and from the switched network. In the present system, the HDT 12 is normally located in a central office and the ISUs 100 are remotely located in the field and distributed in various locations. The HDT 12 and ISUs 100 are connected via the hybrid fiber-coax distribution network 11 in a multi-point to point configuration. In the present system, the modem functionality required to transport information over the HFC distribution network 11 is performed by interface equipment in both the HDT 12 and the ISUs 100. Such modem functionality is performed utilizing orthogonal frequency division multiplexing.

The communication system shall now be generally described with reference to Figures 1, 3 and 6. The primary components of system 10 are host digital terminals (HDTs) 12, video host distribution terminal (VHDT) 34, telephony downstream transmitter 14, telephony upstream receiver 16, the hybrid fiber coax (HFC) distribution network 11 including optical distribution node 18, and integrated service units 66, 68 (shown generally as ISU 100 in Figure 6) associated with remote units 46. The HDT 12 provides telephony interface between the switching network (noted generally by trunk line 20) and the modem interface to the HFC distribution network for transport of telephony information. The telephony downstream transmitter 14 performs electrical to optical conversion of coaxial RF downstream telephony information outputs 22 of an HDT 12, shown in Figure 3, and transmits onto redundant downstream optical feeder lines 24. The telephony upstream receiver 16 performs optical to electrical conversion of optical signals on redundant upstream optical feeder lines 26 and applies electrical signals on coaxial RF upstream telephony information inputs 28 of HDT 12. The optical distribution node (ODN) 18 provides interface between the optical feeder lines 24 and 26 and coaxial distribution legs 30. The ODN 18 combines downstream video and telephony onto coaxial distribution legs 30. The integrated services units provide modem interface to the coaxial distribution network and service interface to customers.

The HDT 12 and ISUs 100 implement the telephony transport system modulator-demodulator (modem) functionality. The HDT 12 includes at least one RF MCC modem 82, shown in Figure 3 and each ISU 100 includes an RF ISU modem 101, shown in Figure 6. The MCC modems 82 and ISU modems 101 use a multi-carrier RF transmission technique to transport telephony information, such as DS0+ channels, between the HDT 12 and ISUs 100. This multi-carrier technique is based on orthogonal frequency division multiplexing (OFDM) where a bandwidth of the system is divided up into multiple carriers, each of which may represent an information channel. Multi-carrier modulation can be viewed as a technique which takes time-division multiplexed information data and transforms it to frequency-division

multiplexed data. The generation and modulation of data on multiple carriers is accomplished digitally, using an orthogonal transformation on each data channel. The receiver performs the inverse transformation on segments of the sampled waveform to demodulate the data. The multiple carriers overlap spectrally. However, as a consequence of the orthogonality of the transformation, the data in each carrier can be demodulated with negligible interference from the other carriers, thus reducing interference between data signals transported. Multi-carrier transmission obtains efficient utilization of the transmission bandwidth, particularly necessary in the upstream communication of a multi-point to point system. Multi-carrier modulation also provides an efficient means to access multiple multiplexed data streams and allows any portion of the band to be accessed to extract such multiplexed information, provides superior noise immunity to impulse noise as a consequence of having relatively long symbol times, and also provides an effective means for eliminating narrowband interference by identifying carriers which are degraded and inhibiting the use of these carriers for data transmission (such channel monitoring and protection is described in detail below). Essentially, the telephony transport system can disable use of carriers which have interference and poor performance and only use carriers which meet transmission quality targets.

Further, the ODNs 18 combine downstream video with the telephony information for transmission onto coaxial distribution legs 30. The video information from existing video services, generally shown by trunk line 20, is received by and processed by head end 32. Head end 32 or the central office, includes a video host distribution terminal 34 (VHDT) for video data interface. The VHDT 34 has optical transmitters associated therewith for communicating the video information to the remote units 46 via the ODNs 18 of the distribution network 11.

The telephony transmitter 14 of the HDTs 12, shown in Figure 3 and 4, includes two transmitters for downstream telephony transmission to protect the telephony data transmitted. These transmitters are conventional and relatively inexpensive narrow band laser transmitters. One transmitter is in

standby if the other is functioning properly. Upon detection of a fault in the operating transmitter, the transmission is switched to the standby transmitter. In contrast, the transmitter of the VHDT 34 is relatively expensive as compared to the transmitters of HDT 12 as it is a broad band analog DFB laser transmitter. Therefore, protection of the video information, a non-essential service unlike telephony data, is left unprotected. By splitting the telephony data transmission from the video data transmission, protection for the telephony data alone can be achieved. If the video data information and the telephony data were transmitted over one optical fiber line by an expensive broad band analog laser, economies may dictate that protection for telephony services may not be possible. Therefore, separation of such transmission is of importance.

Further with reference to Figure 1, the video information is optically transmitted downstream via optical fiber line 40 to splitter 38 which splits the optical video signals for transmission on a plurality of optical fiber lines 42 to a plurality of optical distribution nodes 18. The telephony transmitter 14 associated with the HDT 12 transmits optical telephony signals via optical fiber feeder line 42 to the optical distribution nodes 18. The optical distribution nodes 18 convert the optical video signals and optical telephony signals for transmission as electrical outputs via the coaxial distribution portion of the hybrid fiber coax (HFC) distribution network 11 to a plurality of remote units 46. The electrical downstream video and telephony signals are distributed to ISUs via a plurality of coaxial legs 30 and coaxial taps 44 of the coaxial distribution portion of the HFC network 11.

The remote units 46 have associated therewith an ISU 100, shown generally in Figure 6, that includes means for transmitting upstream electrical data signals including telephony information, such as from telephones and data terminals, and in addition may include means for transmitting set top box information from set top boxes 45 as described further below. The upstream electrical data signals are provided by a plurality of ISUs 100 to an optical distribution node 18 connected thereto via the coaxial portion of the HFC distribution network 11. The optical distribution node 18 converts the

upstream electrical data signals to an upstream optical data signal for transmission over an optical fiber feeder line 26 to the head end 32.

Figure 2 generally shows an alternate embodiment for providing transmission of optical video and optical telephony signals to the optical distribution nodes 18 from head end 32, the HDT 12 and VHDT 34 in this embodiment utilize the same optical transmitter and the same optical fiber feeder line 36. The signals from HDT 12 and VHDT 34 are combined and transmitted optically from headend 32 to splitter 38. The combined signal is then split by splitter 38 and four split signals are provided to the optical distribution nodes 18 for distribution to the remote units by the coaxial distribution legs 30 and coaxial taps 44. Return optical telephony signals from the ODNs 18 would be combined at splitter 38 for provision to the headend. However, as described above, the optical transmitter utilized would be relatively expensive due to its broad band capabilities, lessening the probabilities of being able to afford protection for essential telephony services.

As one skilled in the art will recognize, the fiber feeder lines 24, 26, as shown in Figure 1, may include four fibers, two for transmission downstream from downstream telephony transmitter 14 and two for transmission upstream to upstream telephony receiver 16. With the use of directional couplers, the number of such fibers may be cut in half. In addition, the number of protection transmitters and fibers utilized may vary as known to one skilled in the art and any listed number is not limiting to the present invention as described in the accompanying claims.

The present invention shall now be described in further detail. The first part of the description shall primarily deal with video transport. The remainder of the description shall primarily be with regard to telephony transport.

#### VIDEO TRANSPORT

The communication system 10 includes the head end 32 which receives video and telephony information from video and telephony service providers via trunk line 20. Head end 32 includes a plurality of HDTs 12 and a VHDT

34. The HDT 12 includes a network interface for communicating telephony information, such as T1, ISDN, or other data services information, to and from telephony service providers, such communication also shown generally by trunk line 20. The VHDT 34 includes a video network interface for communicating video information, such as cable TV video information and interactive data of subscribers to and from video service providers, such communication also shown generally by trunk line 20.

The VHDT 34 transmits downstream optical signals to a splitter 38 via video optical fiber feeder line 40. The passive optical splitter 38 effectively makes four copies of the downstream high bandwidth optical video signals. The duplicated downstream optical video signals are distributed to the correspondingly connected optical distribution nodes 18. One skilled in the art will readily recognize that although four copies of the downstream video signals are created, any number of copies may be made by an appropriate splitter and that the present invention is not limited to any specific number.

The splitter is a passive means for splitting broad band optical signals without the need to employ expensive broad band optical to electrical conversion hardware. Optical signal splitters are commonly known to one skilled in the art and available from numerous fiber optic component manufacturers such as Gould, Inc. In the alternative, active splitters may also be utilized. In addition, a cascaded chain of passive or active splitters would further multiply the number of duplicated optical signals for application to an additional number of optical distribution nodes and therefore increase further the remote units serviceable by a single head end. Such alternatives are contemplated in accordance with the present invention as described by the accompanying claims.

The VHDT 34 can be located in a central office, cable TV head end, or a remote site and broadcast up to about 112 NTSC channels. The VHDT 34 includes a transmission system like that of a LiteAmp™ system available from American Lightwave Systems, Inc., currently a subsidiary of the assignee hereof. Video signals are transmitted optically by amplitude modulation of a 1300 nanometer laser source at the same frequency at which the signals are

received (i.e. the optical transmission is a terahertz optical carrier which is modulated with the RF video signals). The downstream video transmission bandwidth is about 54-725 MHz. One advantage in using the same frequency for optical transmission of the video signal as the frequency of the video signals when received is to provide high bandwidth transmission with reduced conversion expense. This same-frequency transmission approach means that the modulation downstream requires optical to electrical conversion or proportional conversion with a photodiode and perhaps amplification, but no frequency conversion. In addition, there is no sample data bandwidth reduction and little loss of resolution.

An optical distribution node 18, shown in further detail in Figure 5, receives the split downstream optical video signal from the splitter 38 on optical fiber feeder line 42. The downstream optical video signal is applied to a downstream video receiver 400 of the optical distribution node 18. The optical video receiver 400 utilized is like that available in the Lite AMP™ product line available from American Lightwave Systems, Inc. The converted signal from video receiver 400, proportionally converted utilizing photodiodes, is applied to bridger amplifier 403 along with converted telephony signals from downstream telephony receiver 402. The bridger amplifier 403 simultaneously applies four downstream electrical telephony and video signals to diplex filters 406 which allow for full duplex operation by separating the transmit and receive functions when signals of two different frequency bandwidths are utilized for upstream and downstream transmission. There is no frequency conversion performed at the ODN 18 with respect to the video or the downstream telephony signals as the signals are passed through the ODNs to the remote units via the coaxial portion of the HFC distribution network 11 in the same frequency bandwidth as they are received at the ODNs 18.

After the ODN 18 has received the downstream optical video signals and such signals are converted to downstream electrical video signals, the four outputs of the ODN 18 are applied to four coaxial legs 30 of the coaxial portion of the HFC distribution network 11 for transmission of the



downstream electrical video signals to the remote units 46. Such transmission for the electrical video signals occurs in about the 54-725 MHz bandwidth. Each ODN 18 provides for the transmission on a plurality of coaxial legs 30 and any number of outputs is contemplated in accordance with the present invention as described in the accompanying claims.

As shown in Figure 1, each coaxial cable leg 30 can provide a significant number of remote units 46 with downstream electrical video and telephony signals through a plurality of coaxial taps 44. Coaxial taps are commonly known to one skilled in the art and act as passive bidirectional pickoffs of electrical signals. Each coaxial cable leg 30 may have a number of coaxial taps 44 connected in series. In addition, the coaxial portion of the HFC distribution network 11 may use any number of amplifiers to extend the distance data can be sent over the coaxial portion of such distribution network 11.

Downstream video signals are provided from the coaxial taps 44 to the remote units 46. The video signal from the coaxial tap 44 is provided to an HISU 68 which is generally shown by the block diagram of ISU 100 in Figure 6. The ISU 100 is provided with the downstream electrical video and telephony signal from tap 44 and it is applied to diplex filter 104. The downstream electrical video and telephony signal is passed through the diplex filter 104 to both an ingress filter 105 and ISU modem 101. The downstream video signal is passed by the ingress filter 105 to video equipment via an optional set top box 45. The downstream electrical telephony signal applied from the diplex filter 104 to the ISU modem 101 is processed as described in further detail below.

Ingress filter 105 provides the remote unit 46 with protection against interference of signals applied to the video equipment as opposed to those provided to other user equipment such as telephones or computer terminals. Ingress filter 105 passes the video signals; however, it blocks those frequencies not utilized by the video equipment. By blocking those frequencies not used by the video equipment, stray signals are eliminated that may interfere with the other services by the network to at least the same

remote unit.

The set top box 45 is an optional element at the remote unit 46. Interactive video data from set top box 45 would be transmitted by an additional separate RF modem provided by the video service provider at a relatively low frequency in the bandwidth of about 5 to 40 MHz. Such frequency must not be one used for the transport of upstream and downstream telephony data and downstream video.

For an MISU 66, a separate coaxial line from coaxial tap 44 is utilized to provide transmission of video signals from the coaxial tap 44 to the set top box 45 and thus for providing downstream video signals to video equipment 47. The ingress filter 105 as shown in Figure 6 is not a part of the MISU 66 as indicated by its dashed representation.

Alternative embodiments of the VHDT 34 may employ other modulation and mixing schemes or techniques to shift the video signals in frequency, and other encoding methods to transmit the information in a coded format. Such techniques and schemes for transmitting analog video data, in addition to those transmitting digital video data, are known to one skilled in the art and are contemplated in accordance with the spirit and scope of the present invention as described in the accompanying claims.

#### TELEPHONY TRANSPORT

With reference to Figure 3, telephony information and ISU operations and control data (hereinafter referred to as control data) modulated on carriers by MCC modem 82 is transmitted between the HDT 12 and the telephony downstream transmitter 14 via coaxial lines 22. Telephony information and control data modulated on carriers by ISUs 100 is received at telephony upstream receiver 16 and communicated to the MCC modem 82 via coaxial cable lines 28. The telephony downstream transmitter 14 and the telephony upstream receiver 16 transmit and receive, respectively, telephony information and control data via optical fiber feeder lines 24 and 26 to and from a corresponding optical distribution node 18. The control data may include all operations, administration, maintenance & provisioning (OAM&P) for

providing the telephony services of the system 11 and any other control data necessary for providing transport of telephony information between the HDT 12 and the ISUs 100.

A block diagram of the HDT 12 is shown in Figure 3. The HDT 12 includes the following modules: Eight DS1 Units (DS1U) (seven quad-DS1 units 48 plus one protection unit 50), one protection switch & test conversion unit 52 (PSTU), two clock & time slot interchange units 54 (CTSU) (one active and one standby/protection unit), six coax master units 56 (CXMUs) (three active and three standby/protection units), two shelf control units 58 (SCNUs) (one active and one standby/protection unit), and two power supply units 60 (PWRUs) (two load-sharing units which provide the appropriate HDT voltages from a central office supply).

The HDT 12 comprises all the common equipment functions of the telephony transport of the communication system 10. The HDT 12 is normally located in a central office and directly interfaces to a local digital switch or digital network element equipment. The HDT provides the network interface 62 for all telephony information. Each HDT accommodates from 2 to 28 DSX-1 inputs at the network interface 62, representing a maximum of 672 DS0 channels.

The HDT 12 also provides all synchronization for telephony transport in the system 11. The HDT 12 may operate in any one of three synchronization modes: external timing, line timing or internal timing. External timing refers to synchronization to a building integrated timing supply reference which is sourced from a central office in which the HDT 12 is located. Line timing is synchronized to the recovered clock from a DSX-1 signal normally derived from the local digital switch. Internal timing is a free-running or hold-over operation where the HDT maintains its own synchronization in the absence of any valid reference inputs.

The HDT 12 also provides quarter-DS0 grooming capabilities and implements a 4096 x 4096 full-access, non-blocking quarter-DS0 (16 kbps) cross-connect capability. This allows DS0s and quarter-DS0s (ISDN "D" channels) to be routed from any timeslot at the DSX-1 network interface 62 to

any customer serviced by any ISU 100.

The HDT 12 further provides the RF modem functionality required for telephony transport over the HFC distribution network 11 including the MCC modem 82. The HDT 12 accommodates up to three active CXMUs 56 for providing the modem interface to the HFC distribution network 11 and also provides one-for-one protection for each active CXMU 56.

The HDT 12 coordinates the telephony transport system including control and communication of many ISUs of the multi-point to point communication system 11. Each HDT 12 module performs a function. The DS1U module 48 provides the interface to the digital network and DSX-1 termination. The PSTU 52 provides DS1U equipment protection by switching the protection DS1U 50 for a failed DS1U module 48. The CTSU 54 provides the quarter-DS0 timeslot grooming capability and all system synchronization functions. The CTSU 54 also coordinates all call processing in the system. The CXMU 56, described in further detail below, provides the modem functionality and interface for the OFDM telephony transport over the HFC distribution network 11 and the SCNU 58 supervises the operation of the entire communication system providing all OAM&P functions for telephony transport. Most processing of requests for provisioning is performed by the SCNU 58.

#### Downstream Telephony Transmitter

The downstream telephony transmitter 14, shown in Figure 4, takes the coaxial RF outputs 22 from the active CXMUs 56 of the HDT 12 which carry telephony information and control data and combines the outputs 22 into a downstream telephony transmission signal. The electrical-to-optical conversion logic required for the optical transmission is implemented in a stand-alone downstream telephony transmitter 14 rather than in the HDT 12 to provide a more cost effective transport solution. By placing this function in a separate component, the expense of this function does not need to be replicated in each CXMU 56 of the HDT 12. This reduces the cost of the CXMU 56 function and allows the CXMU 56 to transmit and receive over

coax instead of fiber. The downstream telephony transmitter 14 also provides for transmission on redundant downstream fiber feeder lines 24 to an ODN 18.

The downstream telephony transmitter 14 is co-located with the HDT 12 preferably within a distance of 100 feet or less. The downstream telephony transmitter 14 receives the coaxial RF outputs from the active CXMUs 56, each within a 6 MHz frequency band, and combines them at combiner 25 into a single RF signal. Each 6 MHz frequency band is separated by a guard band as is known to one skilled in the art. Downstream telephony information is then transmitted in about the 725-800 MHz frequency band. The telephony transmitter 14 passes the combined signal through a 1-to-2 splitter (not shown), thereby producing redundant downstream electrical signals. The two redundant signals are each delivered to redundant laser transmitters 501 for electrical-to-optical conversion and the redundant signals modulate an optical output such that the output of the downstream telephony transmitter 14 is on two optical feeder lines 24, each having an identical signal modulated thereon. This provides protection for the downstream telephony portion of the present system. Both Fabry-Perot lasers in the telephony transmitter 14 are active at all times. All protection functions are provided at the receive end of the optical transmission (located at the ODN 18) where one of two receivers is selected as "active;" therefore, the telephony transmitter 14 requires no protection switching capabilities.

#### Upstream Telephony Receiver

The upstream telephony receiver 16 performs the optical-to-electrical conversion on the upstream optical telephony signals on the upstream optical feeder lines 26 from the ODN 18. The upstream telephony receiver 16 is normally co-located in the central office with the HDT 12, and provides an electrical coaxial output to the HDT 12, and a coaxial output 23 to be provided to a video set-top controller (not shown). Upstream telephony information is routed via coax lines 28 from the upstream telephony receiver 16 to active CXMUs 56 of the HDT 12. The coaxial link 28 between the

HDT 12 and the upstream telephony receiver 16 is preferably limited to a distance of 100 feet or less and is an intra-office link. Video set-top controller information, as described in the Video Transport section hereof, is located in a bandwidth of the RF spectrum of 5-40 MHz which is not utilized for upstream telephony transport such that it is transmitted along with the upstream telephony information.

The upstream telephony receiver 16 has dual receivers 502 for the dual upstream optical fiber feeders lines 26. These feeder lines 26 carry redundant signals from the ODN 18 which contain both telephony information and control data and also video set-top box information. The upstream telephony receiver 16 performs automatic protection switching on the upstream feeder lines 26 from the ODN. The receiver 502 selected as "active" by protection logic is split to feed the coaxial outputs 28 which drive the HDT 12 and output 23 is provided to the set-top controller (not shown).

15

#### Optical Distribution Node

Referring to Figure 5, the ODN 18 provides the interface between the optical feeder lines 24 and 26 from the HDT 12 and the coaxial portion of the HFC distribution network 11 to the remote units 46. As such, the ODN 18 is essentially an optical-to-electrical and electrical-to-optical converter. The maximum distance over coax of any ISU 100 from an ODN 18 is preferably about 6 km and the maximum length of the combined optical feeder line/coaxial drop is preferably about 20 km. The optical feeder line side of the ODN 18 terminates six fibers although such number may vary. They include: a downstream video feeder line 42 (single fiber from video splitter 38), a downstream telephony feeder line 24 (from downstream telephony transmitter 14), a downstream telephony protection feeder line 24 (from downstream telephony transmitter 14), an upstream telephony feeder line 26 (to upstream telephony receiver 16), an upstream protection feeder line 26 (to upstream telephony receiver 16), and a spare fiber (not shown). The ODN 18 provides protection switching functionality on the receive optical feeder lines 24 from the downstream telephony transmitter. The ODN provides redundant

transmission on the upstream optical feeder lines 26 to the upstream telephony receiver. Protection on the upstream optical feeder lines is controlled at the upstream telephony receiver 16. On the coaxial distribution side of ODN 18, the ODN 18 terminates up to four coaxial legs 30.

5           In the downstream direction, the ODN 18 includes downstream telephony receiver 402 for converting the optical downstream telephony signal into an electrical signal and a bridger amplifier 403 that combines it with the converted downstream video signal from downstream video receiver 400 terminated at the ODN 18 from the VHDT 34. This combined wide-band  
10 electrical telephony/video signal is then transported in the spectrum allocated for downstream transmission, for example, the 725-800 MHz band, on each of the four coaxial legs of the coaxial portion of the HFC distribution network  
11. As such, this electrical telephony and video signal is carried over the coaxial legs 30 to the ISUs 100; the bridger amplifier 403 simultaneously  
15 applying four downstream electrical telephony and video signals to diplex filters 406. The diplex filters 406 allow for full duplex operation by separating the transmit and receive functions when signals at two different frequency bandwidths are utilized for upstream and downstream transmission. There is no frequency conversion available at the ODN 18 for downstream  
20 transport as the telephony and video signals are passed through the ODN 18 to the remote units 46 via the coaxial portion of HFC distribution network 11 in the same frequency bandwidth as they are received at the ODN 18. As shown in Figure 1, each coaxial leg 30 can provide a significant number of remote  
25 units 46 with downstream electrical video and telephony signals through a plurality of coaxial taps 44. Coaxial taps 44 commonly known to one skilled in the art act as passive bidirectional pickoffs of electrical signals. Each coaxial leg 30 may have a number of coaxial taps connected in a series. In addition, the coaxial portion of the HFC distribution network 11 may use any number of amplifiers to extend the distance data can be sent over the coaxial  
30 portions of the system 10. The downstream electrical video and telephony signals are then provided to an ISU 100 (Figure 6), which, more specifically, may be an HISU 68 or an MISU 66 as shown in Figure 1.

In the upstream direction, telephony and set top box information is received by the ODN 18 at diplex filters 406 over the four coaxial legs 30 in the RF spectrum region from 5 to 40 MHz. The ODN 18 may include optional frequency shifters 64 equipped on up to three of four coaxial legs 30.

5 These frequency shifters 64, if utilized, mix the upstream spectrum on a coaxial leg to a higher frequency prior to combining with the other three coaxial legs. Frequency shifters 64 are designed to shift the upstream spectrum in multiples of 50 MHz. For example, the frequency shifters 64 may be provisioned to mix the upstream information in the 5-40 MHz portion

10 of the RF spectrum to any of the following ranges: 50 to 100 MHz, 100 to 150 MHz, or 150 to 200 MHz. This allows any coaxial leg 30 to use the same portion of the upstream RF spectrum as another leg without any spectrum contention when the upstream information is combined at the ODN 18. Provisioning of frequency shifters is optional on a coaxial leg 30. The

15 ODN 18 includes combiner 408 which combines the electrical upstream telephony and set top box information from all the coaxial legs 30 (which may or may not be frequency shifted) to form one composite upstream signal having all upstream information present on each of the four coaxial legs 30. The composite electrical upstream signal is passively 1:2 split and each signal

20 feeds an upstream Fabry-Perot laser transmitter which drives a corresponding upstream fiber feeder line 26 for transmission to the upstream telephony receiver 16.

If the upstream telephony and set top box signals are upshifted at the ODN 18, the upstream telephony receiver 16 includes frequency shifters 31 to

25 downshift the signals according to the upshifting done at the ODN 18. A combiner 33 then combines the downshifted signals for application of a combined signal to the HDT 12. Such downshifting and combining is only utilized if the signals are upshifted at the ODN 18.

30 Integrated Services Unit (ISUs)

Referring to Figure 1, the ISUs 100, such as HISU 68 and MISU 66, provide the interface between the HFC distribution network 11 and the



customer services for remote units 46. Two basic types of ISUs are shown, which provide service to specific customers. Multiple user integrated service unit 66 (MISUs) may be a multiple dwelling integrated service unit or a business integrated service unit. The multiple dwelling integrated service unit  
5 may be used for mixed residential and business environments, such as multi-tenant buildings, small businesses and clusters of homes. These customers require services such as plain old telephone service (POTS), data services, DS1 services, and standard TR-57 services. Business integrated service units are designed to service business environments. They may require more  
10 services, for example, data services, ISDN, DS1 services, higher bandwidth services, such as video conferencing, etc. Home integrated services units 68 (HISUs) are used for residential environments such as single-tenant buildings and duplexes, where the intended services are POTS and basic rate integrated digital services network (ISDN). Description for ISUs shall be limited to the  
15 HISUs and MISUs for simplicity purposes as multiple dwelling and business integrated service units have similar functionality as far as the present invention is concerned.

All ISUs 100 implement RF modem functionality and can be generically shown by ISU 100 of Figure 6. ISU 100 includes ISU modem  
20 101, coax slave controller unit (CXSU) 102, channel units 103 for providing customer service interface, and diplex filter/tap 104. In the downstream direction, the electrical downstream telephony and video signal is applied to diplex filter/tap 104 which passes telephony information to ISU modem 101 and video information to video equipment via an ingress filter 105 in the case  
25 of a HISU. When the ISU 100 is a MISU 66, the video information is rejected by the diplex filter. The ISU modem 101 demodulates the downstream telephony information utilizing a modem corresponding to the MCC modem 82 used for modulating such information on orthogonal multicarriers at HDT 12. ISU 100 demodulates downstream telephony  
30 information from a coaxial distribution leg 30 in a provisionable 6 MHz frequency band. Timing generation 107 of the ISU modem 101 provides clocking for CXSU 102 which provides processing and controls reception and

transmission by ISU modem 101. The demodulated data from ISU modem 101 is passed to the applicable channel units 103 via CXSU 102 depending upon the service provided. For example, the channel units 103 may include line cards for POTS, DS1 services, ISDN, other data services, etc. Each ISU  
5 100 provides access to a fixed subset of all channels available in a 6 MHz frequency band corresponding to one of the CXMUs of HDT 12. This subset of channels varies depending upon the type of ISU 100. An MISU 66 may provide access to many DSO channels in a 6 MHz frequency band, while an HISU 68 may only provide access to a few DSO channels.

10 The channel units 103 provide telephony information and control data to the CXSU 102, which provides such data to ISU modem 101 and controls ISU modem 101 for modulation of such telephony data and control data in a provisional 6 MHz frequency band for transmission onto the coaxial  
15 distribution leg 30 connected thereto. The upstream 6 MHz frequency band provisionable for transmission by the ISU 100 to the HDT 12 corresponds to one of the downstream 6 MHz bands utilized for transmission by the CXMUs 56 of HDT 12.

The CXSU 102 which applies demodulated data from the ISU modem 101 to the applicable channel units, performs data integrity checking on the  
20 downstream 10 bit DS0+ packets received from the ISU modem 101. Each ten bit DS0+ packet as described below includes a parity or data integrity bit. The CXSU 102 will check the parity of each downstream 10 bit DS0+  
channel it receives. Further, the parity of each upstream DS0+ received from the channel units 103 is calculated and a parity bit inserted as the tenth bit of  
25 the upstream DS0+ for decoding and identification by the HDT 12 of an error in the upstream data. If an error is detected by CXSU 102 when checking the parity of a downstream 10 bit DS0+ channel it receives, the parity bit of the corresponding upstream channel will be intentionally inverted to inform the  
HDT 12 of a parity error in the downstream direction. Therefore, the  
30 upstream parity bit is indicative of errors in the downstream DS0+ channel and the corresponding upstream DS0+ channel. An example of such a parity bit generation process is described in U.S. patent application 08/074,913

entitled "Point-to Multipoint Performance Monitoring and Failure Isolation System" assigned to the assignee hereof. This upstream parity bit is utilized in channel monitoring as described further below. As would be apparent to one skilled in the art, the parity checking and generation may be performed, at least in part, in other elements of the ISU or associated therewith such as the channel units.

Each ISU 100 recovers synchronization from downstream transmission, generates all clocks required for ISU data transport and locks these clocks to the associated HDT timing. The ISUs 100 also provide call processing functionality necessary to detect customer line seizure and line idle conditions and transmit these indications to the HDT 12. ISUs 100 terminate and receive control data from the HDT 12 and process the control data received therefrom. Included in this processing are messages to coordinate dynamic channel allocation in the communication system 10. Finally, ISUs 100 generate ISU operating voltages from a power signal received over the HFC distribution network 11 as shown by the power signal 109 taken from diplex filter/tap 104.

#### Data Path in HDT

The following is a detailed discussion of the data path in the host digital terminal (HDT) 12. Referring to Figure 3, the data path between the network facility at the network interface 62 and the downstream telephony transmitter 14 proceeds through the DS1U 48, CTSU 54, and CXMU 56 modules of the HDT 12, respectively, in the downstream direction. Each DS1U 48 in the HDT 12 takes four DS1s from the network and formats this information into four 24-channel, 2.56 Mbps data streams of modified DS0 signals referred to as CTSU inputs 76. Each DS0 in the CTSU input has been modified by appending a ninth bit which can carry multiframe timing, signaling information and control/status messages (Figure 7A). This modified DS0 is referred to as a "DS0+." The ninth bit signal (NBS) carries a pattern which is updated each frame and repeats every 24 frames. This maps each 64 kbps DS0 from the network into a 72 kbps DS0+. Thus, the twenty-four DS0 channels available on each DS1 are formatted along with overhead

information into twenty-four DS0+ channels on each of four CTSU input streams.

The ninth bit signaling (NBS) is a mechanism developed to carry the multiframe timing, out-of-band signaling bits and miscellaneous status and control information associated with each DS0 between the DS1U and the channel units. Its main functions are to carry the signaling bits to channel units 103 and to provide a multiframe clock to the channel units 103 so that they can insert upstream bit signaling into the DS0 in the correct frame of the multiframe. Because downstream DS0s may be coming from DS1s which do not share the same multiframe phase each DS0 must carry a multiframe clock or marker which indicates the signaling frames associated with the origination DS1. The NBS provides this capability. Ninth bit signaling is transparent to the OFDM modem transport of the communication system 11.

Up to eight DS1Us 48 may be equipped in a single HDT 12; including seven active DS1Us 48 and a protection DS1U module 50. Thus, 32 CTSU inputs are connected between the DS1Us and the CTSUs 54 but a maximum of 28 can be enabled to carry traffic at any one time. The four remaining CTSU inputs are from either the protection DS1U or a failed DS1U. The PSTU includes switch control for switching the protection DS1U 50 for a failed DS1U.

Each CTSU input is capable of carrying up to 32, 10-bit channels, the first 24 channels carry DS0+s and the remaining bandwidth is unused. Each CTSU input 76 is clocked at 2.56 Mbps and is synchronized to the 8 kHz internal frame signal (Figure 7C). This corresponds to 320 bits per 125  $\mu$ sec frame period. These 320 bits are framed as shown in Figure 7A. The fourteen gap bits 72 at the beginning of the frame carry only a single activity pulse in the 2nd bit position, the remaining 13 bits are not used. Of the following 288 bits, the first 216 bits normally carry twenty-four DS0+ channels where each DS0+ corresponds to a standard 64 kbps DS0 channel plus the additional 8 kbps signaling bit. Thus, each DS0+ has a bandwidth of 72 kbps (nine bits every 8 Khz frame). The remaining 72 bits are reserved for additional DS0+ payload channels. The final eighteen bits 74 of the frame

are unused gap bits.

The clock and time slot interchange unit 54 (CTSU) of the HDT 12 takes information from up to 28 active CTSU input data streams 76 and cross-connects them to up to twenty-four 32-channel, 2.56 Mbps output data streams 5 78 which are input to the coax master units (CXMUs) 56 of the HDT 12. The format of the data streams between the CTSU 54 and the CXMUs 56 is referred to as a CTSU output. Each CTSU output can also carry up to 32, 10-bit channels like the CTSU input. The first 28 carry traffic and the remaining bandwidth is unused. Each CTSU output is clocked at 2.56 Mbps and is 10 synchronized to the 8 kHz internal framing signal of the HDT 12 (Figure 7C). This corresponds to 320 bits per 125  $\mu$ sec frame period. The frame structure for the 320 bits are as described above for the CTSU input structure.

The HDT 12 has the capability of time and space manipulation of quarter-DS0 packets (16 kbps). This function is implemented with the time 15 slot interchange logic that is part of CTSU 54. The CTSU implements a 4096 x 4096 quarter-DS0 cross-connect function, although not all time slots are utilized. In normal operation, the CTSU 54 combines and relocates up to 672 downstream DS0+ packets (or up to 2688 quarter-DS0 packets) arranged as 28 CTSU inputs of 24 DS0+s each, into 720 DS0+ packets (or 2880 quarter-DS0 20 packets) arranged as 24 CTSU outputs of 32 DS0+s each.

The system has a maximum throughput of 672 DS0+ packets at the network interface so not all of the CTSU output bandwidth is usable. If more than the 672 channels are assigned on the "CTSU output" side of the CTSU, this implies concentration is being utilized. Concentration is discussed further 25 below.

Each CXMU 56 is connected to receive eight active CTSU outputs 78 from the active CTSU 54. The eight CTSU outputs are clocked by a 2.56 MHz system clock and each carries up to 32 DS0+s as described above. The DS0+s are further processed by the CXMU 56 and a tenth parity bit is 30 appended to each DS0+ resulting in a 10 bit DSO+. These 10 bit packets contain the DS0, the NBS (ninth bit signal) and the parity or data integrity bit (Figure 7B). The 10 bit packets are the data transmitted on the HFC

distribution network 11 to the ISUs 100. The 10th bit or data integrity bit inserted in the downstream channels is decoded and checked at the ISU and utilized to calculate and generate a parity bit for corresponding channels in the upstream as described above. This upstream parity bit which may be  
5 representative of an error in the downstream or upstream channel is utilized to provide channel protection or monitoring as further described herein.

In the upstream direction, the reverse path through the HDT is substantially a mirror of the forward path through the HDT 12. For example, the tenth parity bit is processed at the CXMU 56 and the signal from the  
10 CXMU 56 to the CTSU 54 is in the format of Figure 7A.

The round trip delay of a DS0 is the same for every data path. The time delay over the path from the downstream CTSU output, through CXMU 56, over the HFC distribution network to the ISU 100 and then from the ISU 100, back over the HFC distribution network 11, through CXMU 56 and to  
15 CTSU 54 is controlled by upstream synchronization, as described in detail below. Generally, path delay is measured for each ISU and if it is not the correct number of frames long, the delay length is adjusted by adding delay to the path at the ISU 100.

#### 20 Coax Master Unit (CXMU)

The coax master unit 56 (CXMU), shown in Figure 3, includes the coax master card logic 80 (CXMC) and the master coax card (MCC) modem 82. As previously described, up to six CXMUs may be equipped in an HDT 12. The 6 CXMUs 56 include three pairs of CXMUs 56 with each pair  
25 providing for transmit in a 6 MHz bandwidth. Each pair of CXMUs 56 includes one active CXMU and a standby CXMU. Thus, one to one protection for each CXMU is provided. As shown in Figure 3, both CXMUs of the pair are provided with upstream telephony data from the upstream telephony receiver 16 and are capable of transmitting via the coaxial line 22 to  
30 the downstream telephony transmitter 14. As such, only a control signal is required to provide for the one-to-one protection indicating which CXMU 56 of the pair is to be used for transmission or reception.

Coax Master Card Logic (CXMC)

The coax master card logic 80 (CXMC) of the CXMU 56 (Figure 8), provides the interface between the data signals of the HDT 12, in particular of the CTSU 54, and the modem interface for transport of data over the HFC distribution network 11. The CXMC 80 interfaces directly to the MCC modem 82. The CXMC 80 also implements an ISU operations channel transceiver for multi-point to point operation between the HDT 12 and all ISUs 100 serviced in the 6 MHz bandwidth in which the CXMU 56 controls transport of data within. Referring to Figure 8, the CXMC includes controller and logic 84, downstream data conversion 88, upstream data conversion 90, data integrity 92, IOC transceiver 96, and timing generator 94.

Downstream data conversion 88 performs the conversion from the nine-bit channel format from CTSU 54 (Figure 7A) to the ten-bit channel format (Figure 7B) and generates the data integrity bit in each downstream channel transported over the HFC distribution network 11. The data integrity bit represents odd parity. Downstream data conversion 80 is comprised of at least a FIFO buffer used to remove the 32 gap bits 72, 74 (Figure 7A) present in the downstream CTSU outputs and insert the tenth, data integrity bit, on each channel under control of controller and logic 84.

The upstream data conversion 90 includes at least a FIFO buffer which evaluates the tenth bit (data integrity) appended to each of the upstream channels and passes this information to the data integrity circuitry 92. The upstream data conversion 90 converts the data stream of ten-bit channels (Figure 7B) back to the nine-bit channel format (Figure 7A) for application to CTSU 54. Such conversion is performed under control of controller and logic 84.

The controller and logic 84 also manages call processing and channel allocation for the telephony transport over the HFC network 11 and maintains traffic statistics over the HFC distribution network 11 in modes where dynamic time-slot allocation is utilized, such as for providing TR-303 services, concentration services commonly known to those skilled in the art. In addition, the controller 84 maintains error statistics for the channels in the 6

MHz band in which the CXMU transports data, provides software protocol for all ISU operations channel communications, and provides control for the corresponding MCC modem 82.

The data integrity 92 circuitry processes the output of the tenth bit  
5 evaluation of each upstream channel by the upstream conversion circuit 90. In the present system, parity is only guaranteed to be valid on a provisioned channel which has a call in progress. Because initialized and activated ISU transmitters may be powered down when the ISUs are idle, the parity evaluation performed by the CXMC is not always valid. A parity error  
10 detected indicates either a transmission error in an upstream channel or a transmission error in a downstream channel corresponding to the upstream channel.

The ISU operations channel (IOC) transceiver 96 of the CXMC 80 contains transmit buffers to hold messages or control data from the controller  
15 and logic 84 and loads these IOC control messages which are a fixed total of 8 bytes in length into a 64 kbps channel to be provided to the MCC modem 82 for transport on the HFC distribution network 11. In the upstream direction, the IOC transceiver receives the 64 kbps channel via the MCC modem 82 which provides the controller and logic 84 with such messages.

The timing generator circuit 94 receives redundant system clock inputs  
20 from both the active and protection CTSUs 54 of the HDT 12. Such clocks include a 2 kHz HFC multiframe signal, which is generated by the CTSU 54 to synchronize the round trip delay on all the coaxial legs of the HFC distribution network. This signal indicates multiframe alignment on the ISU  
25 operations channel and is used to synchronize symbol timing and data reconstruction for the transport system. A 8 kHz frame signal is provided for indicating the first "gap" bit of a 2.56 MHz, 32 channel signal from the CTSU 54 to the CXMU 56. A 2.048 MHz clock is generated by the CTSU 54 to the SCNU 58 and the CXMU 56. The CXMU 56 uses this clock for ISU  
30 operations channel and modem communication between the CXMC 80 and the MCC modem 82. A 2.56 MHz bit clock is used for transfer of data signals between the DS1Us 48 and CTSUs 54 and the CTSUs 54 and CXMCs 56. A



20.48 MHz bit clock is utilized for transfer of the 10-bit data channels between the CXMC and the MCC.

#### Master Coax Card (MCC) Modem

5           The master coax card (MCC) modem 82 of the CXMU 56 interfaces on one side to the CXMC 80 and on the other side to the telephony transmitter 14 and receiver 16 for transmission on and reception from the HFC distribution network 11. The MCC modem 82 implements the modem functionality for OFDM transport of telephony data and control data. The  
10 block diagram of Figure 3 identifies the associated interconnects of the MCC modem 82 for both upstream and downstream communication. The MCC modem 82 is not an independent module in the HDT 12, as it has no interface to the HDT 12 other than through the CXMC 80 of the CXMU 56. The MCC modem 82 represents the transport system logic of the HDT 12. As  
15 such, it is responsible for implementing all requirements associated with information transport over the HFC distribution network 11. Each MCC modem 82 of the CXMUs 56 of HDT 12 is allocated a maximum bandwidth of 6 MHz in the downstream spectrum for telephony data and control data transport. The exact location of the 6 MHz band is provisionable by the  
20 CXMC 80 over the communication interface via the IOC transceiver 96 between the CXMC 80 and MCC modem 82. The downstream transmission of telephony and control data is in the RF spectrum of about 725 to 800 MHz.

Each MCC modem 82 is allocated a maximum of 6 MHz in the upstream spectrum for receipt of control data and telephony data from the  
25 ISUs within the RF spectrum of about 5 to 40 MHz. Again, the exact location of the 6 MHz band is provisionable by the CXMC 80 over the communication interface between the CXMC 80 and the MCC modem 82.

The MCC modem 82 receives 256 DS0+ channels from the CXMC 80 in the form of a 20.48 MHz signal as described previously above. The MCC  
30 modem 82 transmits this information to all the ISUs 100 using the multicarrier modulation technique based on OFDM as previously discussed herein. The MCC modem 82 also recovers 256 DS0+ multicarrier channels in the

upstream transmission over the HFC distribution network and converts this information into a 20.48 Mbps stream which is passed to CXMC 80. As described previously, the multicarrier modulation technique involves encoding the telephony and control data, such as by quadrature amplitude modulation, into symbols, and then performing an inverse fast fourier transform technique to modulate the telephony and control data on a set of orthogonal multicarriers.

Symbol alignment is a necessary requirement for the multicarrier modulation technique implemented by the MCC modem 82 and the ISU modems 101 in the ISUs 100. In the downstream direction of transmission, all information at an ISU 100 is generated by a single CXMU 56, so the symbols modulated on each multicarrier are automatically phase aligned. However, upstream symbol alignment at a receiver of the MCC modem 82 varies due to the multi-point to point nature of the HFC distribution network 11 and the unequal delay paths of the ISUs 100. In order to maximize receiver efficiency at the MCC modem 82, all upstream symbols must be aligned within a narrow phase margin. This is done by utilizing an adjustable delay parameter in each ISU 100 such that the symbol periods of all channels received upstream from the different ISUs 100 are aligned at the point they reach the HDT 12. This is part of the upstream synchronization process and shall be described further below. In addition, to maintain orthogonality of the multicarriers, the carrier frequencies used for the upstream transmission by the ISUs 100 must be frequency locked to the HDT 12.

Incoming downstream information from the CXMC 80 to the MCC modem 82 is frame aligned to the 2 kHz and 8 kHz clocks provided to the MCC modem 82. The 2 kHz multi-frame signal is used by the MCC modem 82 to convey downstream symbol timing to the ISUs as described in further detail below. This multiframe clock conveys the channel correspondence and indicates the multi-carrier frame structure so that the telephony data may be correctly reassembled at the ISU 100. Two kHz represents the greatest common factor between 10 kHz (the modem symbol rate) and 8 kHz (the data frame rate).

All ISUs 100 will use the synchronization information inserted by the associated MCC modem 82 to recover all downstream timing required by the ISUs 100. This synchronization allows the ISUs 100 to demodulate the downstream information and modulate the upstream transmission in such a way that all ISU 100 transmissions received at the HDT 12 are synchronized to the same reference. Thus, the carrier frequencies used for all ISU 100 upstream transmission will be frequency locked to the HDT 12.

The symbol alignment is performed over synchronization channels in the downstream and upstream 6 MHz bandwidths under the responsibility of the MCC modem 82, in addition to providing path delay adjustment, initialization and activation, and provisioning over such synchronization channels until initialization and activation is complete as further described herein. These parameters are then tracked by use of the IOC channels. Because of their importance in the system, the IOC channel and synchronization channels may use a different modulation scheme for transport of control data between the MCC modem 82 and ISUs 100 which is more robust or of lesser order (less bits/sec/Hz or bits/symbol) than used for transport of telephony data. For example, the telephony data may be modulated using quadrature amplitude modulation, while the IOC channel and synchronization channel may be modulated utilizing BPSK modulation techniques.

The MCC modem 82 also demodulates telephony and control data modulated on multicarriers by the ISUs 100. Such demodulation is described further below with respect to the various embodiments of the telephony transport system.

Functions with respect to the OFDM transport system for which the MCC modem 82 is responsible, include at least the following, which are further described with respect to the various embodiments in further detail. The MCC modem 82 detects a received amplitude/level of a synchronization pulse/pattern from an ISU 100 within a synchronization channel and passes an indication of this level to the CXMC 80 over the communication interface therebetween. The CXMC 80 then provides a command to the MCC modem

82 for transmission to the ISU 100 being leveled for adjustment of the amplitude level thereof. The MCC modem 82 also provides for symbol alignment of all the upstream multicarriers by correlating an upstream pattern modulated on a synchronization channel with respect to a known symbol boundary and passing a required symbol delay correction to the CXMC 80 over the communication interface therebetween. The CXMC 80 then transmits via the MCC modem 82 a message downstream to the ISU 100 to adjust the symbol delay of the ISU 100.

Likewise, with regard to synchronizing an ISU 100 for overall path delay adjustment, the MCC modem 82 correlates an upstream multiframe pattern modulated in the proper bandwidth by the ISU 100 on the IOC channel with respect to a known reference boundary, and passes a required path delay correction to the CXMC 80 over the modem interface therebetween. The CXMC 80 then transmits via the MCC modem 82 over the IOC channel a message downstream to adjust the overall path delay of an ISU 100.

#### Summary of Bidirectional Multi-Point to Point Telephony Transport

The following summarizes the transport of telephony and control information over the HFC distribution network 11. Each CXMU 56 of HDT 12 is provisioned with respect to its specific upstream and downstream operating frequencies. The bandwidth of both upstream and downstream transmission by the CXMU 56 are a maximum of 6 MHz, with the downstream transmission in a 6 MHz band of the RF spectrum of about 725-800 MHz.

In the downstream direction, each MCC modem 82 of the CXMU 56 provides electrical telephony and control data signals to the downstream telephony transmitter 14 via coaxial line 22 in its provisional 6 MHz bandwidth. The RF electrical telephony and control data signals from the MCC modems 82 of the HDT 12 are combined into a composite signal. The downstream telephony transmitter then passes the combined electrical signal to redundant electrical-to-optical converters for modulation onto a pair of

protected downstream optical feeder lines 24.

The downstream optical feeder lines 24 carry the telephony information and control data to an ODN 18. At the ODN 18, the optical signal is converted back to electrical and combined with the downstream video information (from the video head-end feeder line 42) into an electrical downstream RF output signal. The electrical RF output signal including the telephony information and control data is then fed to the four coaxial distribution legs 30 by ODN 18. All telephony information and control data downstream is broadcast on each coaxial leg 30 and carried over the coaxial portion of the HFC distribution network 11. The electrical downstream output RF signal is tapped from the coax and terminated on the receiver modem 101 of an ISU 100 through diplex filter 104, shown in Figure 6.

The RF electrical output signals include telephony information and control data modulated on orthogonal multicarriers by MCC modem 82 utilizing orthogonal frequency division multiplexing techniques; the telephony information and control data being mapped into symbol data and the symbols being modulated on a plurality of orthogonal carriers using fast fourier transform techniques. As the symbols are all modulated on carriers at a single point to be transmitted to multiple points in the system 11, orthogonality of the multicarriers and symbol alignment of the symbols modulated on the orthogonal multicarriers are automatically aligned for transport over the HFC distribution network 11 and the telephony information and control data is demodulated at the ISUs 100 by the modem 101.

The ISU 100 receives the RF signal tapped from the coax of the coaxial portion of the HFC network 11. The RF modem 101 of the ISU 100 demodulates the signal and passes the telephony information and control data extracted to the CXSU controller 102 for provision to channel units 103 as appropriate. The ISU 100 represents the interface where the telephony information is converted for use by a subscriber or customer.

The CXMUs 56 of the HDT 12 and the ISUs 100 implement the bidirectional multi-point to point telephony transport system of the communication system 10. The CXMUs 56 and the ISUs, therefore, carry out

the modem functionality. The transport system in accordance with the present invention may utilize three different modems to implement the modem functionality for the transport system. The first modem is the MCC modem 82 which is located in each CXMU 56 of the HDT 12. The HDT 12, for example, includes three active MCC modems 82 (Figure 3) and is capable of supporting many ISUs 100, representing a multi-point to point transport network. The MCC modem 82 coordinates telephony information transport as well as control data transport for controlling the ISUs 100 by the HDT 12. For example, the control data may include call processing messages, dynamic allocation and assignment messages, ISU synchronization control messages, ISU modem control messages, channel unit provisioning, and any other ISU operation, administration, maintenance and provisioning (OAM&P) information.

The second modem is a single family subscriber or HISU modem optimized to support a single dwelling residential unit. Therefore, it must be low in cost and low in power consumption. The third modem is the multiple subscriber or MISU modem, which is required to generally support both residential and business services.

The HISU modem and the MISU modem may take several forms. For example, the HISU modem and the MISU modem may, as described further in detail below with regard to the various embodiments of the present invention, extract only a small portion of the multicarriers transmitted from the HDT 12 or a larger portion of the multicarriers transmitted from the HDT 12. For example, the HISU may extract 20 multicarriers or 10 payload channels of telephony information transported from the HDT 12 and the MISU may extract information from 260 multicarriers or 130 payload channels transported from the HDT 12. Each of these modems may use a separate receiver portion for extracting the control data from the signal transported by the HDT 12 and an additional receiver portion of the HISU modem to extract the telephony information modulated on the multicarriers transported from the HDT 12. This shall be referred to hereinafter as an out of band ISU modem. The MCC modem 82 for use with an out of band ISU

modem may modulate control information within the orthogonal carrier waveform or on carriers somewhat offset from such orthogonal carriers. In contrast to the out of band ISU modem, the HISU and MISU modems may utilize a single receiver for the ISU modem and extract both the telephony  
5 information and control data utilizing the single receiver of the modem. This shall be referred to hereinafter as an in-band ISU modem. In such a case, the control data is modulated on carriers within the orthogonal carrier waveform but may utilize different carrier modulation techniques. For example, BPSK for modulation of control data on the carriers as opposed to modulation of  
10 telephony data on payload carriers by QAM techniques. In addition, different modulation techniques may be used for upstream or downstream transmission for both control data and telephony data. For example, downstream telephony data may be modulated on the carriers utilizing 256 QAM and upstream telephony data may be modulated on the carriers utilizing 32 QAM.

15 Whatever modulation technique is utilized for transmission dictates what demodulation approach would be used at the receiving end of the transport system. Demodulation of the downstream telephony information and control data transported by the HDT 12 shall be explained in further detail below with reference to block diagrams of different modem embodiments.

20 In the upstream direction, each ISU modem 101 at an ISU 100 transmits upstream on at least one orthogonal multicarrier in a 6 MHz bandwidth in the RF spectrum of about 5 to 40 MHz; the upstream 6 MHz band corresponding to the downstream 6 MHz band in which transmissions are received. The upstream electrical telephony and control data signals are  
25 transported by the ISU modems 101 to the respectively connected optical distribution node 18 as shown in Figure 1 via the individual coaxial cable legs 30. At the ODN 18, the upstream signals from the various ISUs are combined and transmitted optically to the HDT 12 via optical feeder lines 26. As previously discussed, the upstream electrical signals from the various ISUs  
30 may, in part, be frequency shifted prior to being combined into a composite upstream optical signal. In such a case, the telephony receiver 16 would include corresponding downshifting circuitry.

Due to the multi-point to point nature of transport over the HFC distribution network 11 from multiple ISUs 100 to a single HDT 12, in order to utilize orthogonal frequency division multiplexing techniques, symbols modulated on each carrier by the ISUs 100 must be aligned within a certain phase margin. In addition, as discussed in further detail below, the round trip path delay from the network interface 62 of the HDT 12 to all ISUs 100 and back from the ISUs 100 to the network interface 62 in the communication system 10 must be equal. This is required so that signaling multiframe integrity is preserved throughout the system. In addition, a signal of proper amplitude must be received at the HDT 12 to perform any control functions with respect to the ISU 100. Likewise, with regard to OFDM transport from the ISUs 100, the ISUs 100 must be frequency locked to the HDT 12 such that the multicarriers transported over the HFC distribution network 11 are orthogonally aligned. The transport system implements a distributed loop technique for implementing this multi-point to point transport utilizing orthogonal frequency division multiplexing as further described below. When the HDT 12 receives the plurality of multicarriers which are orthogonally aligned and which have telephony and control data modulated thereon with symbols aligned, the MCC modems 82 of the CXMUs 56 demodulate the telephony information and control data from the plurality of multicarriers in their corresponding 6 MHz bandwidth and provide such telephony data to the CTSU 54 for delivery to the network interface 62 and the control data to the CXMC 80 for control of the telephony transport.

As one skilled in the art will recognize, the spectrum allocations, frequency assignments, data rates, channel numbers, types of services provided and any other parameters or characteristics of the system which may be a choice of design are to be taken as examples only. The invention as described in the accompanying claims contemplates such design choices and they therefore fall within the scope of such claims. In addition, many functions may be implemented by software or hardware and either implementation is contemplated in accordance with the scope of the claims even though reference may only be made to implementation by one or the other.



First Embodiment of Telephony Transport System

The first embodiment of the telephony transport system in accordance with the present invention shall be described with particular reference to Figures 9-23 which include block diagrams of MCC modems 82, and HISU modems and MISU modems shown generally as ISU modem 101 in Figure 6. Such modems implement the upstream and downstream modem transport functionality. Following this description is a discussion on the theory of operation utilizing such modems.

Referring to Figure 9A, the spectrum allocation for one 6 MHz band for upstream and downstream transport of telephony information and control data utilizing OFDM techniques is shown. The waveform preferably has 240 payload channels or DS0+ channels which include 480 carriers or tones for accommodating a net data rate of 19.2 Mbps. 24 IOC channels including 46 carriers or tones, and 2 synchronization channels. Each synchronization channel includes two carriers or tones and is each offset from 24 IOC channels and 240 payload channels by 10 unused carriers or tones, utilized as guard tones. The total carriers or tones is 552. The synchronization tones utilized for synchronization functions as described further below are located at the ends of the 6 MHz spectrum and the plurality of orthogonal carriers in the 6 MHz band are separated from carriers of adjacent 6 MHz bands by guard bands (516.0 kHz) at each end of the 6 MHz spectrum. The guard bands are provided at each end of the 6 MHz band to allow for filter selectivity at the transmitter and receivers of the system. The synchronization carriers are offset from the telephony data or payload carriers such that if the synchronization carrier utilized for synchronization during initialization and activation is not orthogonal with the other tones or carriers within the 6 MHz band, the synchronization signal is prevented from destroying the structure of the orthogonally aligned waveform. The synchronization tones are, therefore, outside of the main body of payload carriers of the band and interspersed IOC channels, although the synchronization channel could be considered a special IOC channel.

To minimize the power requirement of the ISUs, the amount of

bandwidth that an ISU processes is minimized. As such, the telephony payload channels and IOC channels of the 6 MHz band are interspersed in the telephony payload channels with an IOC channel located every 10 payload channels. With such a distributed technique, wherein subbands of payload channels greater than 10 include an IOC channel, the amount of bandwidth an ISU "sees" can be limited such that an IOC channel is available for the HDT 12 to communicate with the ISU 100. Such subband distribution for the spectral allocation shown in Figure 9A is shown in Figure 9D. There are 24 subbands in the 6 MHz bandwidth with each subband including 10 payload channels with an IOC channel between the 5th and 6th payload channels. A benefit of distributing the IOC channels throughout the 6 MHz band is protection from narrow band ingress. If ingress destroys an IOC channel, there are other IOC channels available and the HDT 12 can re-tune an ISU 100 to a different portion of the 6 MHz band, where an IOC channel that is not corrupted is located.

Preferably, the MISU 66 sees approximately 3 MHz of the 6 MHz bandwidth to receive up to 130 payload channels which bandwidth also includes numerous IOC channels for communication from the HDT 12 to the MISU 66. The HISU 68 sees about 100 kHz of the 6 MHz bandwidth to receive 11 channels including at least one IOC channel for communication with the HDT 12.

The primary difference between the downstream and upstream paths are the support of downstream synchronization and upstream synchronization. In the downstream direction, all ISUs lock to information from the HDT (point to multi-point). The initialization and activation of ISUs are based on signals supplied in the upstream synchronization channel. During operation, ISUs track the synchronization via the IOC channels. In the upstream, the upstream synchronization process involves the distributed (multi-point to point) control of amplitude, frequency, and timing; although frequency control can also be provided utilizing only the downstream synchronization channel as described further below. The process of upstream synchronization occurs in one of the two upstream synchronization channels, the primary or the

secondary synchronization channel.

Referring to Figure 10, the downstream transmission architecture of the MCC modem 82 is shown. Two serial data inputs, approximately 10 Mbps each, comprise the payload data from the CXMC 56 which is clocked by the 8 kHz frame clock input. The IOC control data input from the CXMC 56 is clocked by the IOC clock input, which is preferably a 2.0 kHz clock. The telephony payload data and the IOC control data enter through serial ports 132 and the data is scrambled as known to one skilled in the art by scrambler 134 to provide randomness in the waveform to be transmitted over the HFC distribution network 11. Without scrambling, very high peaks in the waveform may occur; however, if the waveform is scrambled the symbols generated by the MCC modem 82 become sufficiently random and such peaks are sufficiently limited.

The scrambled signals are applied to a symbol mapping function 136. The symbol mapping function 136 takes the input bits and maps them into a complex constellation point. For example, if the input bits are mapped into a symbol for output of a BPSK signal, every bit would be mapped to a single symbol in the constellation as in the mapping diagram for BPSK of Figure 9C. Such mapping results in inphase and quadrature values (I/Q values) for the data. BPSK is the modulation technique preferably used for the upstream and downstream IOC channels and the synchronization channels. BPSK encoding is preferred for the IOC control data so as to provide robustness in the system as previously discussed. For QPSK modulation, every two bits would map into one of four complex values that represent a constellation point. In the preferred embodiment, 32 QAM is utilized for telephony payload data, wherein every five bits of payload data is mapped into one of 32 constellation points as shown in Figure 9B. Such mapping also results in I/Q values. As such, one DS0+ signal (10 bits) is represented by two symbols and the two symbols are transmitted using two carriers. Thus, one DS0+ channel is transported over two carriers or tones of 6 MHz spectrum.

One skilled in the art will recognize that various mapping or encoding techniques may be utilized with different carriers. For example, telephony

channels carrying ISDN may be encoded using QPSK as opposed to telephony channels carrying POTS data being encoded using 32 QAM. Therefore, different telephony channels carrying different services may be modulated differently to provide for more robust telephony channels for those services that require such quality. The architecture in accordance with the present invention provides the flexibility to encode and modulate any of the channels differently from the modulation technique used for a different channel.

Each symbol that gets represented by the I/Q values is mapped into a fast fourier transform (FFT) bin of symbol buffer 138. For example, for a DS0+, running at 8 kHz frame rate, five bits are mapped into one FFT bin and five bits into another bin. Each bin or memory location of the symbol buffer 138 represents the payload data and control data in the frequency domain as I/Q values. One set of FFT bins gets mapped into the time domain through the inverse FFT 140, as is known to one skilled in the art. The inverse FFT 140 maps the complex I/Q values into time domain samples corresponding to the number of points in the FFT. Both the payload data and IOC data are mapped into the buffer 138 and transformed into time domain samples by the inverse FFT 140. The number of points in the FFT 140 may vary, but in the preferred embodiment the number of points is 256. The output of the inverse FFT 140, for a 256 point FFT, is 256 time domain samples of the waveform.

The inverse FFT 140 has separate serial outputs for inphase and quadrature (I/Q) components, FFT1 and FFT0. Digital to analog converters 142 take the inphase and quadrature components, which is a numeric representation of baseband modulated signal and convert it to a discrete waveform. The signal then passes through reconstruction filters 144 to remove harmonic content. This reconstruction is needed to avoid problems arising from multiple mixing schemes and other filtering problems. The signal is summed in a signal conversion transmitter 146 for up-converting the I/Q components utilizing a synthesized waveform that is digitally tunable with the inphase and quadrature components for mixing to the applicable transmit frequency. For example, if the synthesizer is at 600 MHz, the output

frequency will be at 600 MHz. The components are summed by the signal conversion transmitter 146 and the waveform including a plurality of orthogonal carriers is then amplified by transmitter amplifier 148 and filtered by transmitter filter 150 before being coupled onto the optical fiber by way of telephony transmitter 14. Such functions are performed under control of general purpose processor 149 and other processing circuitry of block 147 necessary to perform such modulation. The general purpose processor also receives ISU adjustment parameters from carrier, amplitude, timing recovery block 222 (Figure 15) for carrying out distributed loop symbol alignment, frequency locking, amplitude adjustment, and path delay functions as described further below.

At the downstream receiving end, either an MISU or an HISU provides for extracting telephony information and control data from the downstream transmission in one of the 6 MHz bandwidths. With respect to the MISU 66, the MISU downstream receiver architecture is shown in Figure 11. It includes a 100 MHz bandpass filter 152 to reduce the frequency band of the received 600 to 850 MHz total band broadcast downstream. The filtered signal then passes through voltage tuned filters 154 to remove out of band interference and further reduce the bandwidth. The signal is down converted to baseband frequency via quadrature and inphase down convertor 158 where the signal is mixed at complex mixers 156 utilizing synthesizer 157 which is controlled from an output of serial ports 178. The down converted I/Q components are passed through filters 159 and converted to digital format at analog to digital convertors 160. The time domain samples of the I/Q components are placed in a sample buffer 162 and a set of samples are input to down convertor compensation unit 164. The compensation unit 164 attempts to mitigate errors such as DC offsets from the mixers and differential phase delays that occur in the down conversion.

Carrier, amplitude and timing signaling are extracted from the compensated signal, by the carrier, amplitude, and timing recovery block 166 by extracting control data from the synchronization channels during initialization and activation of the ISU and the IOC channels during tracking

as further described below with reference to Figure 22A. The compensated signal in parallel form is provided to fast fourier transform (FFT) 170 to be converted into a vector of frequency domain elements which are essentially the complex constellation points with I/Q components originally created upstream at the MCC modem 82 for the DS0+ channels which the MISU sees. Due to inaccuracies in channel filtering, an equalizer 172 removes dynamic errors that occur during transmission and reception. Equalization in the upstream receiver and the downstream receiver architectures shall be explained in further detail below with reference to Figure 23. From the equalizer 172, the complex constellation points are converted to bits by symbol to bit convertor 174, descrambled at descrambler 176 which is a mirror element of scrambler 134, and the payload telephony information and IOC control data are output by the serial ports 178 to the CXSU 102 as shown in Figure 6. Block 153 includes the processing capabilities for carrying out the various functions as shown therein.

Referring to Figure 12, the HISU 68 downstream receiver architecture is shown. The primary difference between the HISU downstream receiver architecture (Figure 12) and the MISU downstream receiver architecture (Figure 11) is the amount of bandwidth being processed. The front ends of the receivers up to the FFT processing are substantially the same, except during the down conversion, the analog to digital converters 160 can be operated at a much slower rate. For instance, if the bandwidth of the signal being processed is 100 kHz, the sample rate can be approximately 200 kHz. In an MISU processing a 3 MHz signal, the sample rate is about 6 MHz. Since the HISU is limited to receiving a maximum of 10 DS0+s, the FFT 180 can be of a smaller size. A 32 point FFT 180 is preferably used in the HISU and can be implemented more efficiently, compared to a 128 or 256 point FFT utilized in the MISU. Therefore, the major difference between these architectures is that the HISU receiver architecture requires substantially less signal processing capability than the MISU receiver and as such has less power consumption. Thus, to provide a system wherein power consumption at the remote units is minimized, the smaller band of frequencies seen by the

HISU allows for such low consumption. One reason the HISU is allowed to see such a small band of carriers is that the IOC channels are interspersed throughout the 6 MHz spectrum.

Referring to Figure 13, the upstream transmission architecture for the HISU 68 is shown. The IOC control data and the telephony payload data from the CXSU 102 (Figure 6) is provided to serial ports 182 at a much slower rate in the HISU than in the MISU or HDT transmission architectures, because the HISU supports only 10 DS0+ channels. The HISU upstream transmission architecture implements three important operations. It adjusts the amplitude of the signal transmitted, the timing delay (both symbol and path delay) of the signal transmitted, and the carrier frequency of the signal transmitted. The telephony data and IOC control data enters through the serial ports 182 under control of clocking signals generated by the clock generator 173 of the HISU downstream receiver architecture, and is scrambled by scrambler 184 for the reasons stated above with regard to the MCC downstream transmission architecture. The incoming bits are mapped into symbols, or complex constellation points, including I/Q components in the frequency domain, by bits to symbol converter 186. The constellation points are then placed in symbol buffer 188. Following the buffer 188, an inverse FFT 190 is applied to the symbols to create time domain samples; 32 samples corresponding to the 32 point FFT. A delay buffer 192 is placed on the output of the inverse FFT 190 to provide multi-frame alignment at MCC modem upstream receiver architecture as a function of the upstream synchronization process controlled by the HDT 12. The delay buffer 192, therefore, provides a path delay adjustment prior to digital to analog conversion by the digital to analog converters 194 of the inphase and quadrature components of the output of the inverse FFT 190. Clock delay 196 provides a fine tune adjustment for the symbol alignment at the request of IOC control data output obtained by extracting control data from the serial stream of data prior to being scrambled. After conversion to analog components by digital to analog convertors 194, the analog components therefrom are reconstructed into a smooth analog waveform by the

reconstruction filters 198. The upstream signal is then directly up converted by direct convertor 197 to the appropriate transmit frequency under control of synthesizer block 195. Synthesizer block 195 is operated under control of commands from an IOC control channel which provides carrier frequency adjustment commands thereto as extracted in the HISU downstream receiver architecture. The up converted signal is then amplified by transmitter amplifier 200, filtered by transmitter filter 202 and transmitted upstream to be combined with other signals transmitted by other ISUs 100. The block 181 includes processing circuitry for carrying out the functions thereof.

Referring to Figure 14, the upstream transmitter architecture for the MISU 66 is shown and is substantially the same as the upstream transmitter architecture of HISU 68. However, the MISU 66 handles more channels and cannot perform the operation on a single processor as can the HISU 68. Therefore, both a processor of block 181 providing the functions of block 181 including the inverse FFT 191 and a general purpose processor 206 to support the architecture are needed to handle the increased channel capacity.

Referring to Figure 15, the MCC upstream receiver architecture of each CXMU 56 at the HDT 12 is shown. A 5 to 40 MHz band pass filter 208 filters the upstream signal which is then subjected to a direct down conversion to baseband by mixer and synthesizer circuitry 211. The outputs of the down conversion is applied to anti-alias filters 210 for conditioning thereof and the output signal is converted to digital format by analog to digital converters 212 to provide a time domain sampling of the inphase and quadrature components of the signal to narrow band ingress filter and FFT 112. The narrow band ingress filter and FFT 112, as described below, provides protection against narrow band interference that may affect the upstream transmission.

The ingress filter and FFT 112 protects ten channels at a time, therefore, if ingress affects one of the available 240 DS0+s in the 6 MHz spectrum received by MCC modem 82, a maximum of ten channels will be destroyed from the ingress. The ingress filter and FFT 112 includes a polyphase structure, as will be recognized by one skilled in the art as a common filter technique. It will be further recognized by one skilled in the art



that the number of channels protected by the polyphase filter can be varied. The output of the ingress filter and FFT 112 is coupled to an equalizer 214 which provides correction for inaccuracies that occur in the channel, such as those due to noise from reference oscillators or synthesizers. The output  
5 symbols of the equalizer 214, are applied to a symbols to bits converter 216 where the symbols are mapped into bits. The bits are provided to descramblers 218, which are a mirror of the scramblers of the ISUs 100 and the output of the descramblers are provided to serial ports 220. The output of the serial ports is broken into two payload streams and one IOC control data  
10 stream just as is provided to the MCC downstream transmitter architecture in the downstream direction. Block 217 includes the necessary processing circuitry for carrying out the functions therein.

In order to detect the downstream information, the amplitude, frequency, and timing of the arriving signal must be acquired using the  
15 downstream synchronization process. Since the downstream signal constitutes a point to multi-point node topology, the OFDM waveform arrives via a single path in an inherently synchronous manner, in contrast to the upstream signal. Acquisition of the waveform parameters is initially performed on the downstream synchronization channels in the downstream synchronization  
20 bands located at the ends of the 6 MHz spectrum. These synchronization bands include a single synchronization carrier or tone which is BPSK modulated by a 2 kHz framing clock. This tone is used to derive initial amplitude, frequency, and timing at the ISU. The synchronization carrier may be located in the center of the receive band and could be considered a special  
25 case of an IOC. After the signal is received and the receiver architecture is tuned to a typical IOC channel, the same circuitry is used to track the synchronization parameters using the IOC channel.

The process used to acquire the necessary signal parameters utilizes carrier, amplitude and timing recovery block 166 of the ISU receiver  
30 architecture, which is shown in more detail in block diagram form in Figure 22A. The carrier, amplitude and timing recovery block 166 includes a Costas loop 330 which is used to acquire the frequency lock for the received

waveform. After the signal is received from the compensation unit 164, a sample and hold 334 and analog to digital conversion 332 is applied to the signal with the resulting samples from the convertors 332 applied to the Costas loop 330. The sampling is performed under control of voltage  
5 controlled oscillator 340 as divided by divider 333 which divides by the number of points of the FFT utilized in the receiver architecture, M. The mixers 331 of the Costas loop 330 are fed by the arriving signal and the feedback path, and serve as the loop phase detectors. The output of the mixers 331 are filtered and decimated to reduce the processing requirements  
10 of subsequent hardware. Given that the received signal is band-limited, less samples are required to represent the synchronization signal. If orthogonality is not preserved in the receiver, the filter will eliminate undesired signal components from the recovery process. Under conditions of orthogonality, the LPF 337 will completely remove effects from adjacent OFDM carriers. When  
15 carrier frequency lock is achieved, the process will reveal the desired BPSK waveform in the inphase arm of the loop. The output of the decimators are fed through another mixer, then processed through the loop filter with filter function  $H(s)$  and numerically controlled oscillator (NCO), completing the feedback path to correct for frequency error. When the error is at a "small"  
20 level, the loop is locked. In order to achieve fast acquisition and minimal jitter during tracking, it will be necessary to employ dual loop bandwidths. System operation will require that frequency lock is achieved and maintained within about +/- 4% of the OFDM channel spacing (360 Hz).

The amplitude of the signal is measured at the output of the frequency  
25 recovery loop at BPSK power detector 336. The total signal power will be measured, and can be used to adjust a numerically controllable analog gain circuit (not shown). The gain circuit is intended to normalize the signal so that the analog to digital convertors are used in an optimal operating region.

Timing recovery is performed using an early-late gate type algorithm  
30 of early-late gate phase detector 338 to derive timing error, and by adjusting the sample clock or oscillator 340 in response to the error signal. The early-late gate detector results in an advance/retard command during an update

interval. This command will be applied to the sample clock or oscillator 340 through filter 341. This loop is held off until frequency lock and amplitude lock have been achieved. When the timing loop is locked, it generates a lock indicator signal. The same clocks are also used for the upstream transmission.

5 The carrier, timing and amplitude recovery block 166 provides a reference for the clock generator 168. The clock generator 168 provides all of the clocks needed by the MISU, for example, the 8 kHz frame clock and the sample clock.

Carrier, amplitude, and timing recovery block 222 of the MCC modem

10 upstream receiver architecture (Figure 15), is shown by the synchronization loop diagram of Figure 22B. It performs detection for upstream synchronization on signals on the upstream synchronization channel. For initialization and activation of an ISU, upstream synchronization is performed by the HDT commanding one of the ISUs via the downstream IOC control

15 channels to send a reference signal upstream on a synchronization channel. The carrier, amplitude, and timing recovery block 222 measures the parameters of data from the ISU 100 that responds on the synchronization channel and estimates the frequency error, the amplitude error, and the timing error compared to references at the HDT 12. The output of the carrier,

20 amplitude, and timing recovery block 222 is turned into adjustment commands by the HDT 12 and sent to the ISU being initialized and activated in the downstream direction on an IOC control channel by the MCC downstream transmitter architecture.

The purpose of the upstream synchronization process is to initialize

25 and activate ISUs such that the waveform from distinct ISUs combine to a unified waveform at the HDT 12. The parameters that are estimated at the HDT 12 by carrier, amplitude, and timing recovery block 222 and adjusted by the ISUs are amplitude, timing, and frequency. The amplitude of an ISUs signal is normalized so that DS0+s are apportioned an equal amount of power,

30 and achieves a desired signal to noise ratio at the HDT 12. In addition, adjacent ISUs must be received at the correct relative level or else weaker DS0+ channels will be adversely impacted by the transient behavior of the

stronger DS0+ channels. If a payload channel is transmitted adjacent to another payload channel with sufficient frequency error, orthogonality in the OFDM waveform deteriorates and error rate performance is compromised. Therefore, the frequency of the ISU must be adjusted to close tolerances.

- 5 Timing of the recovered signal also impacts orthogonality. A symbol which is not aligned in time with adjacent symbols can produce transitions within the part of the symbol that is subjected to the FFT process. If the transitions of all symbols don't fall within the guard interval at the HDT, approximately +/- 16 tones (8 DS0+s) relative to the non-orthogonal channel will be  
10 unrecoverable.

During upstream synchronization, the ISUs will be commanded to send a signal, for example a square wave signal, to establish amplitude and frequency accuracy and to align symbols. The pattern signal may be any signal which allows for detection of the parameters by carrier, amplitude and  
15 timing recovery block 222 and such signal may be different for detecting different parameters. For example, the signal may be a continuous sinusoid for amplitude and frequency detection and correction and a square wave for symbol timing. The carrier, amplitude and timing recovery block 222 estimates the three distributed loop parameters. In all three loops, the resulting  
20 error signal will be converted to a command by the CXMC 80 and sent via the MCC modem 82 over an IOC channel and the CXSU will receive the command and control the adjustment made by the ISU.

As shown in Figure 22B, the upstream synchronization from the ISU is sampled and held 434 and analog to digital converted 432 under control of  
25 voltage controlled oscillator 440. Voltage controlled oscillator is a local reference oscillator which is divided by M, the points of the FFT in the receiver architecture, for control of sample and hold 434 and analog to digital convertor 432 and divided by k to apply an 8 kHz signal to phase detector 438.

- 30 Frequency error may be estimated utilizing the Costas loop 430. The Costas loop 430 attempts to establish phase lock with the locally generated frequency reference. After some period of time, loop adaptation will be

disabled and phase difference with respect to the time will be used to estimate the frequency error. The frequency error is generated by filter function H(s) 444 and provided to the CXMC 82 for processing to send a frequency adjustment command to the ISU via an IOC control channel. The frequency error is also applied to the numerically controlled oscillator (NCO) to complete the frequency loop to correct for frequency error.

The amplitude error is computed based on the magnitude of the carrier during the upstream synchronization by detecting the carrier amplitude of the inphase arm of the Costas loop 430 by power detector 436. The amplitude is compared with a desired reference value at reference comparator 443 and the error will be sent to the CXMC 82 for processing to send an amplitude adjustment command to the ISU via an IOC control channel.

When the local reference in the HDT has achieved phase lock, the BPSK signal on the synchronization channel arriving from the ISU is available for processing. The square wave is obtained on the inphase arm of the Costas loop 430 and applied to early-late gate phase detector 438 for comparison to the locally generated 8 kHz signal from divider 435. The phase detector 435 generates a phase or symbol timing error applied to loop filter 441 and output via line 439. The phase or symbol timing error is then provided to the CXMC 82 for processing to send a symbol timing adjustment command to the ISU via an IOC control channel.

The mechanisms in the ISU which adjust the parameters for upstream synchronization include implementing an amplitude change with a scalar multiplication of the time domain waveform as it is being collected from the digital processing algorithm, such as inverse FFT 190, by the digital to analog convertors 194 (Figure 13). Similarly, a complex mixing signal could be created and implemented as a complex multiply applied to the input to the digital to analog convertors 194.

Frequency accuracy of both the downstream sample clock and upstream sample clock, in the ISU, is established by phase locking an oscillator to the downstream synchronization and IOC information. Upstream transmission frequency is adjusted, for example, at synthesizer block 195 as

commanded by the HDT 12.

Symbol timing corrections are implemented as a delay function. Symbol timing alignment in the ISU upstream direction is therefore established as a delay in the sample timing accomplished by either blanking a  
5 sample interval (two of the same samples to go out simultaneously) or by putting in an extra clock edge (one sample is clocked out and lost) via clock delay 196 (Figure 13). In this manner, a delay function can be controlled without data storage overhead beyond that already required.

After the ISU is initialized and activated into the system, ready for  
10 transmission, the ISU will maintain required upstream synchronization system parameters using the carrier, amplitude, frequency recovery block 222. An unused but initialized and activated ISU will be commanded to transmit on an IOC and the block 222 will estimate the parameters therefrom as explained above.

15 In both the upstream transmitter architectures for the MISU 66 (Figure 13) and the HISU 68 (Figure 14), frequency offset or correction to achieve orthogonality of the carriers at HDT 12 can be determined on the ISU as opposed to the frequency offset being determined at the HDT during synchronization by carrier, amplitude and timing recovery block 222 (Figure  
20 15) and then frequency offset adjustment commands being transmitted to the ISU for adjustment of carrier frequency via the synthesizer blocks 195 and 199 of the HISU 68 and MISU 66, respectively. Thus, frequency error would no longer be detected by carrier, amplitude and timing recovery block 22 as described above. Rather, in such a direct ISU implementation, the ISU,  
25 whether an HISU 68 or MISU 66, estimates a frequency error digitally from the downstream signal and a correction is applied to the upstream data being transmitted.

The HDT 12 derives all transmit and receive frequencies from the same fundamental oscillator. Therefore, all mixing signals are frequency  
30 locked in the HDT. Similarly, the ISU, whether an HISU 68 or MISU 66, derives all transmit and receive frequencies from the same fundamental oscillator; therefore, all the mixing signals on the ISU are also frequency

locked. There is, however, a frequency offset present in the ISU oscillators relative to the HDT oscillators. The amount of frequency error (viewed from the ISU) will be a fixed percentage of the mixing frequency. For example, if the ISU oscillator is 10PPM off in frequency from the HDT oscillators, and  
5 the downstream ISU receiver mix frequency was 100 MHz and the ISU upstream transmit mixing frequency were 10 MHz, the ISU would have to correct for 1 kHz on the downstream receiver and create a signal with a 100 Hz offset on the upstream transmitter. As such, with the ISU direct implementation, the frequency offset is estimated from the downstream signal.

10 The estimation is performed with digital circuitry performing numeric calculations, i.e. a processor. Samples of the synchronization channel or IOC channel are collected in hardware during operation of the system. A tracking loop drives a digital numeric oscillator which is digitally mixed against the received signal. This process derives a signal internally that is essentially  
15 locked to the HDT. The internal numerical mix accounts for the frequency offset. During the process of locking to the downstream signal in the ISU, the estimate of frequency error is derived and with the downstream frequency being known, a fractional frequency error can be computed. Based on the knowledge of the mixing frequency at the HDT that will be used to down  
20 convert the upstream receive signal, an offset to the ISU transmit frequency is computed. This frequency offset is digitally applied to the ISU transmitted signal prior to converting the signal to the analog domain, such as by convertors 194 of Figure 13. Therefore, the frequency correction can be performed directly on the ISU.

25 Referring to Figures 20 and 21, the narrow band ingress filter and FFT 112 of the MCC upstream receiver architecture, including a polyphase filter structure, will be described in further detail. Generally, the polyphase filter structure includes polyphase filters 122 and 124 and provides protection against ingress. The 6 MHz band of upstream OFDM carriers from the ISUs  
30 100 is broken into subbands through the polyphase filters which provide filtering for small groups of carriers or tones, and if an ingress affects carriers within a group of carriers, only that group of carriers is affected and the other

groups of carriers are protected by such filtering characteristics.

The ingress filter structure has two parallel banks 122, 124 of polyphase filters. One bank has approximately 17 different non-overlapping bands with channel spaces between the bands. A magnitude response of a single polyphase filter bank is shown in Figure 18. The second bank is offset from the first bank by an amount so that the channels that are not filtered by the first bank are filtered by the second bank. Therefore, as shown in the closeup magnitude response of a single polyphase filter bank in Figure 19, one band of channels filtered may include those in frequency bins 38-68 with the center carriers corresponding to bins 45-61 being passed by the filter. The overlapping filter provides for filtering carriers in the spaces between the bands and the carriers not passed by the other filter bank. For example, the overlapping filter may pass 28-44. The two channel banks are offset by 16 frequency bins so that the combination of the two filter banks receives every one of the 544 channels.

Referring to Figure 20, the ingress filter structure receives the sampled waveform  $x(k)$  from the analog to digital convertors 212 and then complex mixers 118 and 120 provide the stagger for application to the polyphase filters 122, 124. The mixer 118 uses a constant value and the mixer 120 uses a value to achieve such offset. The outputs of each mixer enters one of the polyphase filters 122, 124. The output of each polyphase filter bank comprises 18 bands, each of which contain 16 usable FFT bins or each band supports sixteen carriers at the 8 kHz rate, or 8 DS0+s. One band is not utilized.

Each band output of the polyphase filters 122, 124 has 36 samples per 8 kHz frame including 4 guard samples and enters a Fast Fourier Transform (FFT) block 126, 128. The first operation performed by the FFT blocks 126, 128 is to remove the four guard samples, thereby leaving 32 time domain points. The output of the each FFT in the blocks is 32 frequency bins, 16 of which are used with the other bins providing filtering. The output of the FFTs are staggered to provide overlap. As seen in Figure 20, carriers 0 - 15 are output by FFT #1 of the top bank, carriers 16 - 31 are output by FFT #1



of the bottom bank, carriers 32 - 48 are output by FFT #2 of the top bank and so on.

The polyphase filters 122, 124 are each standard polyphase filter construction as is known to one skilled in the art and each is shown by the structure of Figure 21. The input signal is sampled at a 5.184 Mega sample per second rate, or 648 samples per frame. The input is then decimated by a factor of 18 (1 of 18 samples are kept) to give an effective sample rate of 288 kHz. This signal is subjected to the finite impulse response (FIR) filters, labeled  $H_{0,0}(Z)$  through  $H_{0,16}(Z)$ , which include a number of taps, preferably 5 taps per filter. As one skilled in the art will recognize the number of taps can vary and is not intended to limit the scope of the invention. The outputs from the filters enter an 18 point inverse FFT 130. The output of the transform is 36 samples for an 8 kHz frame including 4 guard samples and is provided to FFT blocks 126 and 128 for processing as described above. The FFT tones are preferably spaced at 9 kHz, and the information rate is 8 kilosymbols per second with four guard samples per symbol allotted. The 17 bands from each polyphase filter are applied to the FFT blocks 126, 128 for processing and output of the 544 carriers as indicated above. One band, the 18th band, as indicated above, is not used.

The equalizer 214 (Figure 15) and 172 (Figure 11), in both upstream and downstream receiver architectures, is supplied to account for changes in group delay across the cable plant. The equalizer tracks out phase and gain or amplitude variations due to environmental changes and can therefore adapt slowly while maintaining sufficiently accurate tracking. The coefficients 360 of the equalizer 172, 214, for which the internal equalizer operation is generally shown in Figure 23, represent the inverse of the channel frequency response to the resolution of the FFT 112, 170. The downstream coefficients will be highly correlated since every channel will progress through the same signal path as opposed to the upstream coefficients which may be uncorrelated due to the variant channels that individual DS0+s may encounter in the multi-point to point topology. While the channel characteristics are diverse, the equalizer will operate the same for either upstream or downstream receiver.

The downstream equalizer will track on only the IOC channels, thus reducing the computational requirements at the ISUs and removing the requirement for a preamble in the payload channels, as described further below, since the IOC channels are always transmitted. The upstream, however, will require equalization on a per DS0+ and IOC channel basis.

The algorithm used to update the equalizer coefficients contains several local minima when operating on a 32 QAM constellation and suffers from a four-fold phase ambiguity. Furthermore, each DS0+ in the upstream can emanate from a separate ISU, and can therefore have an independent phase shift. To mitigate this problem, each communication onset will be required to post a fixed symbol preamble prior to data transmission. Note that the IOC channels are excluded from this requirement since they are not equalized and that the preamble cannot be scrambled. It is known that at the time of transmission, the HDT 12 will still have accurate frequency lock and symbol timing as established during initialization and activation of the ISU and will maintain synchronization on the continuously available downstream IOC channel.

The introduction of the preamble requires that the equalizer have knowledge of its process state. Three states are introduced which include: search, acquisition, and tracking mode. Search mode is based on the amount of power present on a channel. Transmitter algorithms will place a zero value in unused FFT bins, resulting in no power being transmitted on that particular frequency. At the receiver, the equalizer will determine that it is in search mode based on the absence of power in the FFT bin.

When transmission begins for an initialized and activated ISU, the equalizer detects the presence of signal and enters the acquisition mode. The length of the preamble may be about 15 symbols. The equalizer will vary the equalization process based on the preamble. The initial phase and amplitude correction will be large but subsequent updates of the coefficients will be less significant.

After acquisition, the equalizer will enter a tracking mode with the update rate being reduced to a minimal level. The tracking mode will

continue until a loss of power is detected on the channel for a period of time. The channel is then in the unused but initialized and activated state. The equalizer will not train or track when the receiver is being tuned and the coefficients will not be updated. The coefficients may be accessed and used  
5 such as by signal to noise detector 305 (Figure 15) for channel monitoring as discussed further below.

For the equalization process, the I/Q components are loaded into a buffer at the output of the FFT, such as FFT 112, 180. As will be apparent to one skilled in the art, the following description of the equalizer structure is  
10 with regard to the upstream receiver equalizer 214 but is equally applicable to the downstream receiver equalizer 172. The equalizer 214 extracts time domain samples from the buffer and processes one complex sample at a time. The processed information is then output therefrom. Figure 23 shows the basic structure of the equalizer algorithm less the state control algorithm  
15 which should be apparent to one skilled in the art. The primary equalization path performs a complex multiply at multiplier 370 with the value from the selected FFT bin. The output is then quantized at symbol quantize block 366 to the nearest symbol value from a storage table. The quantized value (hard decision) is passed out to be decoded into bits by symbols to bits convertor  
20 216. The remainder of the circuitry is used to update the equalizer coefficients. An error is calculated between the quantized symbol value and the equalized sample at summer 364. This complex error is multiplied with the received sample at multiplier 363 and the result is scaled by the adaptation coefficient by multiplier 362 to form an update value. The update value is  
25 summed at summer 368 with the original coefficient to result in a new coefficient value.

#### Operation of First Embodiment

In the preferred embodiment, the 6 MHz frequency band for each  
30 MCC modem 82 of HDT 12 is allocated as shown in Figure 9A. Although the MCC modem 82 transmits and receives the entire 6 MHz band, the ISU modems 100 (Figure 6) are optimized for the specific application for which

they are designed and may terminate/generate fewer than the total number of carriers or tones allocated in the 6 MHz band. The upstream and downstream band allocations are preferably symmetric. The upstream 6 MHz bands from the MCC modems 82 lie in the 5-40 MHz spectrum and the downstream 6 MHz bands lie in the 725-760 MHz spectrum.

There are three regions in each 6 MHz frequency band to support specific operations, such as transport of telephony payload data, transport of ISU system operations and control data (IOC control data), and upstream and downstream synchronization. Each carrier or tone in the OFDM frequency band consists of a sinusoid which is modulated in amplitude and phase to form a complex constellation point as previously described. The fundamental symbol rate of the OFDM waveform is 8 kHz, and there are a total of 552 tones in the 6 MHz band. The following Table 1 summarizes the preferable modulation type and bandwidth allocation for the various tone classifications.

Table 1

<u>Band Allocation</u>	<u>Number of Tones or Carriers</u>	<u>Modulation</u>	<u>Capacity</u>	<u>Bandwidth</u>
20 Synch Band	24 tones(2 synch tones at each end and 10 guard tones at each end)	BPSK	n/a	216 KHz
25 Payload Data	480 (240 DSO + channels)	32 QAM	19.2 MBPS	4.32 MHz
30 IOC	48 (2 every 20 data channels or 24 IOC channels)	BPSK	384 kbps	432 kHz
Intra-band guard	Remainder on each end	n/a	n/a	1.032 MHz (516 kHz at each end)
35 Composite Signal	552	n/a	n/a	6.0 MHz

Guard bands are provided at each end of the spectrum to allow for selectivity filtering after transmission and prior to reception. A total of 240

telephony data channels are included throughout the band, which accommodates a net data rate of 19.2 Mbps. This capacity was designed to account for additive ingress, thereby retaining enough support to achieve concentration of users to the central office. The IOC channels are interspersed throughout the band to provide redundancy and communication support to narrowband receivers located in the HISUs. The IOC data rate is 16 kbps (two BPSK tones at the symbol rate of 8 kHz frames per second). Effectively, an IOC is provided for every 10 payload data channels. An ISU, such as an HISU, that can only see a single IOC channel would be forced to retune if the IOC channel is corrupted. However, an ISU which can see multiple IOC channels can select an alternate IOC channel in the event that the primary choice is corrupt, such as for an MISU.

The synchronization channels are duplicated at the ends of the band for redundancy, and are offset from the main body of usable carriers to guarantee that the synchronization channels do not interfere with the other used channels. The synchronization channels were previously described and will be further described below. The synchronization channels are operated at a lower power level than the telephony payload channels to also reduce the effect of any interference to such channels. This power reduction also allows for a smaller guard band to be used between the synchronization channels and the payload telephony channels.

One synchronization or redundant synchronization channels may also be implemented within the telephony channels as opposed to being offset therefrom. In order to keep them from interfering with the telephony channels, the synchronization channels may be implemented using a lower symbol rate. For example, if the telephony channels are implemented at an 8 kHz symbol rate, the synchronization channels could be implemented at a 2 kHz symbol rate and also may be at a lower power level.

The ISUs 100 are designed to receive a subband, as shown in Figure 9D, of the total aggregate 6 MHz spectrum. As an example, the HISU 68 will preferably detect only 22 of the available 552 channels. This implementation is primarily a cost/power savings technique. By reducing the number of

channels being received, the sample rate and associated processing requirements are dramatically reduced and can be achievable with common conversion parts on the market today.

A given HISU 68 is limited to receiving a maximum of 10 DS0s out of the payload data channels in the HISU receiver's frequency view. The remaining channels will be used as a guard interval. Furthermore, in order to reduce the power/cost requirements, synthesizing frequency steps will be limited to 198 kHz, limiting the HISU tuning scope to 8 channel segments. An IOC channel is provided for as shown in Figure 9D so that every HISU 68 will always see an IOC channel for control of the HISU 68 via HDT 12.

The MISU 66 is designed to receive 13 subbands, as shown in Figure 9D, or 130 of the 240 available DS0s. Again, the tuning steps will be limited to 128 kHz to realize an efficient synthesizer implementation. These are preferred values for the HISU 68 and MISU 66, and it will be noted by one skilled in the art that many of the values specified herein can be varied without changing the scope or spirit of the invention as defined by the accompanying claims.

As known to one skilled in the art, there may be need to support operation over channels in a bandwidth of less than 6 MHz. With appropriate software and hardware modifications of the system, such reconfiguration is possible as would be apparent to one skilled in the art. For example, for a 2 MHz system, in the downstream, the HDT 12 would generate the channels over a subset of the total band. The HISUs are inherently narrowband and would be able to tune into the 2 MHz band. The MISUs supporting 130 channels, would receive signals beyond the 2 MHz band. They would require reduction in filter selectivity by way of a hardware modification. An eighty (80) channel MISU would be able to operate with the constraints of the 2 MHz system. In the upstream, the HISUs would generate signals within the 2 MHz band and the MISUs transmit section would restrict the information generated to the narrower band. At the HDT, the ingress filtering would provide sufficient selectivity against out of band signal energy. The narrowband system would require synchronization bands at the edges of the 2

MHz band.

As previously described, acquisition of signal parameters for initializing the system for detection of the downstream information is performed using the downstream synchronization channels. The ISUs use the carrier, amplitude, timing recovery block 166 to establish the downstream synchronization of frequency, amplitude and timing for such detection of downstream information. The downstream signal constitutes a point to multi-point topology and the OFDM waveform arrives at the ISUs via a single path in an inherently synchronous manner.

10 In the upstream direction, each ISU 100 must be initialized and activated through a process of upstream synchronization before an HDT 12 can enable the ISU 100 for transmission. The process of upstream synchronization for the ISUs is utilized so that the waveform from distinct ISUs combine to a unified waveform at the HDT. The upstream synchronization process, portions of which were previously described, involves various steps. They include: ISU transmission level adjustment, upstream multicarrier symbol alignment, carrier frequency adjustment, and round trip path delay adjustment. Such synchronization is performed after acquisition of a 6 MHz band of operation.

20 Generally, with respect to level adjustment, the HDT 12 calibrates the measured signal strength of the upstream transmission received from an ISU 100 and adjusts the ISU 100 transmit level so that all ISUs are within acceptable threshold. Level adjustment is performed prior to symbol alignment and path delay adjustment to maximize the accuracy of these measurements.

25 Generally, symbol alignment is a necessary requirement for the multicarrier modulation approach implemented by the MCC modems 82 and the ISU modems 101. In the downstream direction of transmission, all information received at the ISU 100 is generated by a single CXMU 56, so the symbols modulated on each multicarrier are automatically phase aligned. However, upstream symbol alignment at the MCC modem 82 receiver architecture varies due to the multi-point to point nature of the HFC

distribution network 11 and the unequal delay paths of the ISUs 100. In order to have maximum receiver efficiency, all upstream symbols must be aligned within a narrow phase margin. This is done by providing an adjustable delay path parameter in each ISU 100 such that the symbol periods of all channels  
5 received upstream from the different ISUs are aligned at the point they reach the HDT 12.

Generally, round trip path delay adjustment is performed such that the round trip delay from the HDT network interface 62 to all ISUs 100 and back to the network interface 62 from all the ISUs 100 in a system must be equal.  
10 This is required so that signaling multiframe integrity is preserved throughout the system. All round trip processing for the telephony transport section has a predictable delay with the exception of the physical delay associated with signal propagation across the HFC distribution network 11 itself. ISUs 100 located at close physical distance from the HDT 12 will have less round trip  
15 delay than ISUs located at the maximum distance from the HDT 12. Path delay adjustment is implemented to force the transport system of all ISUs to have equal round trip propagation delay. This also maintains DS1 multiframe alignment for DS1 channels transported through the system, maintaining in-band channel signaling or robbed-bit signaling with the same alignment for  
20 voice services associated with the same DS1.

Generally, carrier frequency adjustment must be performed such that the spacing between carrier frequencies is such as to maintain orthogonality of the carriers. If the multicarriers are not received at the MCC modem 82 in orthogonal alignment, interference between the multicarriers may occur. Such  
25 carrier frequency adjustment can be performed in a manner like that of symbol timing or amplitude adjustment or may be implemented on the ISU as described previously above.

In the initialization process, when the ISU has just been powered up, the ISU 100 has no knowledge of which downstream 6 MHz frequency band  
30 it should be receiving in which provides the need for the acquisition of 6 MHz band for operation step of the initialization process. Until an ISU 100 has successfully acquired a 6 MHz band for operation, it implements a "scanning"



approach to locate its downstream frequency band. A local processor of the CXSU controller 102 of ISU 100 starts with a default 6 MHz receive frequency band somewhere in the range from 625 to 850 MHz. The ISU 100 waits for a period of time, for example 100 milliseconds, in each 6 MHz band  
5 to look for a valid 6 MHz acquisition command which matches a unique identification number for the ISU 100; which unique identifier may take the form of or be based on a serial number of the ISU equipment. If a valid 6 MHz acquisition command is not found in that 6 MHz band, the CXSU controller 102 looks at the next 6 MHz band and the process is repeated. In  
10 this manner, as explained further below, the HDT 12 can tell the ISU 100 which 6 MHz band it should use for frequency reception and which band for frequency transmission upstream.

The process of initialization and activation of ISUs, as generally described above, and tracking or follow-up synchronization is further  
15 described below. This description is written using an MISU 66 in conjunction with a CXSU controller 103 but is equally applicable to any ISU 100 implemented with an equivalent controller logic. The coax master card logic (CXMC) 80 is instructed by the shelf controller unit (SCNU) 58 to initialize and activate a particular ISU 100. The SCNU uses an ISU designation  
20 number to address the ISU 100. The CXMC 80 correlates the ISU designation number with an equipment serial number, or unique identifier, for the equipment. No two ISU equipments shipped from the factory possess the same unique identifier. If the ISU 100 has never before been initialized and activated in the current system database, the CXMC 80 chooses a personal  
25 identification number (PIN) code for the ISU 100 being initialized and activated. This PIN code is then stored in the CXMC 80 and effectively represents the "address" for all communications with that ISU 100 which will follow. The CXMC 80 maintains a lookup table between each ISU designation number, the unique identifier for the ISU equipment, and the PIN  
30 code. Each ISU 100 associated with the CXMU 56 has a unique PIN address code assignment. One PIN address code will be reserved for a broadcast feature to all ISUs, which allows for the HDT to send messages to all

initialized and activated ISUs 100.

The CXMC 80 sends an initialization and activation enabling message to the MCC modem 82 which notifies the MCC modem 82 that the process is beginning and the associated detection functionality in the MCC modem 82 should be enabled. Such functionality is performed at least in part by carrier, amplitude, timing recovery block 222 as shown in the MCC upstream receiver architecture of Figure 15 and as previously discussed.

The CXMC 80 transmits an identification message by the MCC modem 82 over all IOC channels of the 6 MHz band in which it transmits. The message includes a PIN address code to be assigned to the ISU being initialized and activated, a command indicating that ISU initialization and activation should be enabled at the ISU 100, the unique identifier for the ISU equipment, such as the equipment serial number, and cyclical redundancy checksum (CRC). The messages are sent periodically for a certain period of time. This period of time being the maximum time which an ISU can scan all downstream 6 MHz bands, listening for a valid identification message. The periodic rate, for example 50 msec, affects how quickly the ISU learns its identity. The CXMC 80 will never attempt to synchronize more than one ISU at a time. A software timeout is implemented if an ISU does not respond after some maximum time limit is exceeded. This timeout must be beyond the maximum time limit required for an ISU to obtain synchronization functions.

During periodic transmission by CXMC 80, the ISU implements the scanning approach to locate its downstream frequency band. The local processor of the CXSU starts with a default 6 MHz receive frequency band somewhere in the range from 625 to 850 MHz. The ISU 100 selects the primary synchronization channel of the 6 MHz band and then tests for loss of synchronization after a period of time. If loss of synchronization is still present, the secondary synchronization channel is selected and tested for loss of synchronization after a period of time. If loss of synchronization is still present, then the ISU restarts selection of the synchronization channels on the next 6 MHz band. When loss of synchronization is not present on a

synchronization channel then the ISU selects the first subband including the IOC and listens for a correct identification message. If a correct identification message is found which matches its unique identifier then the PIN address code is latched into an appropriate register. If a correct identification message is not found in the first subband then a middle subband is selected, such as the 11th subband, and the ISU again listens for the correct identification message. If the message again is incorrect, then the ISU restarts on another 6 MHz band. The ISU listens for the correct identification message in a subband for a period of time equal to at least two times the CXMU transmission time, for example 100 msec when transmission time is 50 msec as described above. The initialization and activation commands are unique commands in the ISU 100, as the ISU 100 will not require a PIN address code match to respond to such commands, but only a valid unique identifier and CRC match. However, the initialization and activation command from the CXMC 80 transmitted via the MCC modem 82 will be the only command which an ISU 100 will be allowed to receive without a valid PIN address code match. If an uninitialized and un-activated ISU 100 receives an initialization and activation command from the CXMC 80 via the MCC modem 82 on an IOC channel, data which matches the unique identifier and a valid CRC, the CXSU 102 of the ISU 100 will store the PIN address code transmitted with the command and the unique identifier. From this point on, the ISU 100 will only respond to commands which address it by its correct PIN address code, or a broadcast address code; unless, of course, the ISU is re-activated again and given a new PIN address code.

After the ISU 100 has received a match to its unique identifier, the ISU will receive the upstream frequency band command with a valid PIN address code that tells the ISU 100 which 6 MHz band to use for upstream transmission and the carrier or tone designations for the upstream IOC channel to be used by the ISU 100. The CXSU controller 102 interprets the command and correctly activates the ISU modem 101 of the ISU 100 for the correct upstream frequency band to respond in. Once the ISU modem 101 has acquired the correct 6 MHz band, the CXSU controller 103 sends a message

command to the ISU modem 101 to enable upstream synchronization.

Distributed loops utilizing the carrier, amplitude, and timing recovery block 222 of the MCC modem upstream receiver architecture of the HDT 12 is used to lock the various ISU parameters for upstream transmission, including  
5 amplitude, carrier frequency, symbol alignment, and path delay.

Figure 16 describes this distributed loop generally. When a new unit is hooked to a cable, the HDT 12 instructs the ISU hooked to the cable to go into an upstream synchronization mode exclusive of any other ISU 100. The HDT is then given information on the new ISU and provides downstream  
10 commands for the various parameters to the subscriber ISU unit. The ISU begins transmission in the upstream and the HDT 12 locks to the upstream signal. The HDT 12 derives an error indicator with regard to the parameter being adjusted and commands the subscriber ISU to adjust such parameter. The adjustment of error is repeated in the process until the parameter for ISU  
15 transmission is locked to the HDT 12.

More specifically, after the ISU 100 has acquired the 6 MHz band for operation, the CXSU 102 sends a message command to the ISU modem 101 and the ISU modem 101 transmits a synchronization pattern on a  
20 synchronization channel in the primary synchronization band of the spectral allocation as shown in Figure 9. The upstream synchronization channels which are offset from the payload data channels as allocated in Figure 9 include both a primary and a redundant synchronization channel such that upstream synchronization can still be accomplished if one of the  
synchronization channels is corrupted.

25 The MCC modem 82 detects a valid signal and performs an amplitude level measurement on a received signal from the ISU. The synchronization pattern indicates to the CXMC 80 that the ISU 100 has received the activation and initialization and frequency band commands and is ready to proceed with upstream synchronization. The amplitude level is compared to a desired  
30 reference level. The CXMC 80 determines whether or not the transmit level of the ISU 100 should be adjusted and the amount of such adjustment. If level adjustment is required, the CXMC 80 transmits a message on the

downstream IOC channel instructing the CXSU 102 of the ISU 100 to adjust the power level of the transmitter of the ISU modem 101. The CXMC 80 continues to check the receive power level from the ISU 100 and provides adjustment commands to the ISU 100 until the level transmitted by the ISU 5 100 is acceptable. The amplitude is adjusted at the ISU as previously discussed. If amplitude equilibrium is not reached within a certain number of iterations of amplitude adjustment or if a signal presence is never detected utilizing the primary synchronization channel then the same process is used on the redundant synchronization channel. If amplitude equilibrium is not 10 reached within a certain number of iterations of amplitude adjustment or if a signal presence is never detected utilizing the primary or redundant synchronization channels then the ISU is reset.

Once transmission level adjustment of the ISU 100 is completed and has been stabilized, the CXMC 80 and MCC modem 82 perform carrier 15 frequency locking. The MCC modem 82 detects the carrier frequency as transmitted by the ISU 100 and performs a correlation on the received transmission from the ISU to calculate a carrier frequency error correction necessary to orthogonally align the multicarriers of all the upstream transmissions from the ISUs. The MCC modem 82 returns a message to the 20 CXMC 80 indicating the amount of carrier frequency error adjustment required to perform frequency alignment for the ISU. The CXMC 80 transmits a message on a downstream IOC channel via the MCC modem 82 instructing the CXSU 102 to adjust the transmit frequency of the ISU modem 101 and the process is repeated until the frequency has been established to 25 within a certain tolerance for the OFDM channel spacing. Such adjustment would be made via at least the synthesizer block 195 (Figures 13 and 14). If frequency locking and adjustment is accomplished on the ISU as previously described, then this frequency adjustment method is not utilized.

To establish orthogonality, the CXMC 80 and MCC modem 82 30 perform symbol alignment. The MCC modem 82 detects the synchronization channel modulated at a 8 kHz frame rate transmitted by the ISU modem 101 and performs a hardware correlation on the receive signal to calculate the

delay correction necessary to symbol align the upstream ISU transmission from all the distinct ISUs 100. The MCC modem 82 returns a message to the CXMC 80 indicating the amount of delay adjustment required to symbol align the ISU 100 such that all the symbols are received at the HDT 12

5 simultaneously. The CXMC 80 transmits a message in a downstream IOC channel by the MCC modem 82 instructing the CXSU 103 to adjust the delay of the ISU modem 101 transmission and the process repeats until ISU symbol alignment is achieved. Such symbol alignment would be adjusted via at least the clock delay 196 (Figures 13 and 14). Numerous iterations may be

10 necessary to reach symbol alignment equilibrium and if it is not reached within a predetermined number of iterations, then the ISU may again be reset.

Simultaneously with symbol alignment, the CXMC 80 transmits a message to the MCC modem 82 to perform path delay adjustment. The

15 CXMC 80 sends a message on a downstream IOC channel via the MCC modem 82 instructing the CXSU controller 102 to enable the ISU modem 101 to transmit a another signal on a synchronization channel which indicates the multiframe (2 kHz) alignment of the ISU 100. The MCC modem 82 detects this multiframe alignment pattern and performs a hardware correlation on the

20 pattern. From this correlation, the modem 82 calculates the additional symbol periods required to meet the round trip path delay of the communication system. The MCC modem 82 then returns a message to the CXMC 80 indicating the additional amount of delay which must be added to meet the

25 overall path delay requirements and the CXMC then transmits a message on a downstream IOC channel via the MCC modem 82 instructing the CXSU controller 102 to relay a message to the ISU modem 101 containing the path delay adjustment value. Numerous iterations may be necessary to reach path delay equilibrium and if it is not reached within a predetermined number of

30 iterations, then the ISU may again be reset. Such adjustment is made in the ISU transmitter as can be seen in the display delay buffer "n" samples 192 of the upstream transmitter architectures of Figures 13 and 14. Path delay and symbol alignment may be performed at the same time, separately or together

using the same or different signals sent on the synchronization channel.

Until the ISU is initialized and activated, the ISU 100 has no capability of transmitting telephony data information on any of the 480 tones or carriers. After such initialization and activation has been completed, the ISUs are  
5 within tolerance required for transmission within the OFDM waveform and the ISU is informed that transmission is possible and upstream synchronization is complete.

After an ISU 100 is initialized and activated for the system, follow-up synchronization or tracking may be performed periodically to keep the ISUs  
10 calibrated within the required tolerance of the OFDM transport requirements. The follow-up process is implemented to account for drift of component values with temperature. If an ISU 100 is inactive for extreme periods of time, the ISU can be tuned to the synchronization channels and requested to update upstream synchronization parameters in accordance with the upstream  
15 synchronization process described above. Alternatively, if an ISU has been used recently, the follow-up synchronization or tracking can proceed over an IOC channel. Under this scenario, as generally shown in Figure 17, the ISU 100 is requested to provide a signal over an IOC channel by the HDT 12. The HDT 12 then acquires and verifies that the signal is within the tolerance  
20 required for a channel within the OFDM waveform. If not than the ISU is requested to adjust such errored parameters. In addition, during long periods of use, ISUs can also be requested by the HDT 12 to send a signal on an IOC channel or a synchronization channel for the purpose of updating the upstream synchronization parameters.

25 In the downstream direction, the IOC channels transport control information to the ISUs 100. The modulation format is preferably differentially encoded BPSK, although the differential aspect of the downstream modulation is not required. In the upstream direction, the IOC channels transport control information to the HDT 12. The IOC channels are  
30 differentially BPSK modulated to mitigate the transient time associated with the equalizer when sending data in the upstream direction. Control data is slotted on a byte boundary (500  $\mu$ s frame). Data from any ISU can be

transmitted on an IOC channel asynchronously; therefore, there is the potential for collisions to occur.

As there is potential for collisions, detection of collisions on the upstream IOC channels is accomplished at a data protocol level. The protocol for handling such collisions may, for example, include exponential backoff by the ISUs. As such, when the HDT 12 detects an error in transmission, a retransmission command is broadcast to all the ISUs such that the ISUs retransmit the upstream signal on the IOC channel after waiting a particular time; the wait time period being based on an exponential function.

One skilled in the art will recognize that upstream synchronization can be implemented allowing for multi-point to point transmission using only the symbol timing loop for adjustment of symbol timing by the ISUs as commanded by the HDT. The frequency loop for upstream synchronization can be eliminated with use of high quality local free running oscillators in the ISUs that are not locked to the HDT. In addition, the local oscillators at the ISUs could be locked to an outside reference. The amplitude loop is not essential to achieve symbol alignment at the HDT.

Call processing in the communication system 10 entails the manner in which a subscriber is allocated channels of the system for telephony transport from the HDT 12 to the ISUs 100. The present communication system in accordance with the present invention is capable of supporting both call processing techniques not involving concentration, for example, TR-8 services, and those involving concentration, such as TR-303 services. Concentration occurs when there are more ISU terminations requiring service than there are channels to service such ISUs. For example, there may be 1,000 customer line terminations for the system, with only 240 payload channels which can be allocated to provide service to such customers.

Where no concentration is required, such as for TR-8 operation, channels within the 6 MHz spectrum are statically allocated. Therefore, only reallocation of channels shall be discussed further below with regard to channel monitoring.

On the other hand, for dynamically allocated channels to provide



concentration, such as for providing TR-303 services, the HDT 12 supports on-demand allocation of channels for transport of telephony data over the HFC distribution network 11. Such dynamic allocation of channels is accomplished utilizing the IOC channels for communication between the HDT 5 12 and the ISUs 100. Channels are dynamically allocated for calls being received by a customer at an ISU 100, or for calls originated by a customer at an ISU 100. The CXMU 56 of HDT 12, as previously discussed, implements IOC channels which carry the call processing information between the HDT 12 and the ISUs 100. In particular, the following call processing messages 10 exist on the IOC channels. They include at least a line seizure or off-hook message from the ISU to the HDT; line idle or on-hook message from the ISU to the HDT; enable and disable line idle detection messages between the HDT and the ISUs.

For a call to a subscriber on the HFC distribution network 11, the 15 CTSU 54 sends a message to the CXMU 56 associated with the subscriber line termination and instructs the CXMU 56 to allocate a channel for transport of the call over the HFC distribution network 11. The CXMU 56 then inserts a command on the IOC channel to be received by the ISU 100 to which the call is intended; the command providing the proper information to the CXSU 20 102 to alert the ISU 100 as to the allocated channel.

When a call is originated by a subscriber at the ISU side, each ISU 100 is responsible for monitoring the channel units for line seizure. When line seizure is detected, the ISU 100 must communicate this change along with the PIN address code for the originating line to the CXMU 56 of the HDT 12 25 using the upstream IOC operation channel. Once the CXMU 56 correctly receives the line seizure message, the CXMU 56 forwards this indication to the CTSU 54 which, in turn, provides the necessary information to the switching network to set up the call. The CTSU 54 checks the availability of channels and allocates a channel for the call originated at the ISU 100. Once 30 a channel is identified for completing the call from the ISU 100, the CXMU 56 allocates the channel over the downstream IOC channel to the ISU 100 requesting line seizure. When a subscriber returns on hook, an appropriate

line idle message is sent upstream to the HDT 12 which provides such information to the CTSU 54 such that the channel can then be allocated again to support TR-303 services.

Idle channel detection can further be accomplished in the modem  
5 utilizing another technique. After a subscriber at the ISU 100 has terminated use of a data payload channel, the MCC modem 82 can make a determination that the previously allocated channel is idle. Idle detection may be performed by utilizing the equalization process by equalizer 214 (Figure 15) which  
10 examines the results of the FFT which outputs a complex (I and Q component) symbol value. An error is calculated, as previously described herein with respect to equalization, which is used to update the equalizer coefficients. Typically, when the equalizer has acquired the signal and valid data is being detected, the error will be small. In the event that the signal is  
15 terminated, the error signal will increase, and this can be monitored by signal to noise monitor 305 to determine the termination of the payload data channel used or channel idle status. This information can then be utilized for allocating idle channels when such operation of the system supports concentration.

The equalization process can also be utilized to determine whether an  
20 unallocated or allocated channel is being corrupted by ingress as shall be explained in further detail below with respect to channel monitoring.

The telephony transport system may provide for channel protection from ingress in several manners. Narrowband ingress is a narrowband signal that is coupled into the transmission from an external source. The ingress  
25 signal which is located within the OFDM waveform can potentially take the entire band offline. An ingress signal is (most likely) not orthogonal to the OFDM carriers, and under worst case conditions can inject interference into every OFDM carrier signal at a sufficient level to corrupt almost every DS0+ to an extent that performance is degraded below a minimum bit error rate.

30 One method provides a digitally tunable notch filter which includes an interference sensing algorithm for identifying the ingress location on the frequency band. Once located, the filtering is updated to provide an arbitrary

filter response to notch the ingress from the OFDM waveform. The filter would not be part of the basic modem operation but requires the identification of channels that are degraded in order to "tune" them out. The amount of channels lost as a result of the filtering would be determined in response to  
5 the bit error rate characteristics in a frequency region to determine how many channels the ingress actually corrupted.

Another approach as previously discussed with respect to the ingress filter and FFT 112 of the MCC upstream receiver architecture of Figure 15 is the polyphase filter structure. The cost and power associated with the filter are  
10 absorbed at the HDT 12, while supplying sufficient ingress protection for the system. Thus, power consumption at the ISUs 100 is not increased. The preferred filter structure involves two staggered polyphase filters as previously discussed with respect to Figures 20 and 21 although use of one filter is  
15 clearly contemplated with loss of some channels. The filter/transform pair combines the filter and demodulation process into a single step. Some of the features provided by polyphase filtering include the ability to protect the receive band against narrowband ingress and allow for scalable bandwidth usage in the upstream transmission. With these approaches, if ingress renders  
20 some channels unusable, the HDT 12 can command the ISUs to transmit upstream on a different carrier frequency to avoid such ingress.

The above approaches for ingress protection, including at least the use of digital tunable notch filters and polyphase filters, are equally applicable to point to point systems utilizing multicarrier transport. For example, a single MISU transporting to a single HDT may use such techniques. In addition,  
25 uni-directional multi-point to point transport may also utilize such techniques for ingress protection.

In addition, channel monitoring and allocation or reallocation based thereon may also be used to avoid ingress. External variables can adversely affect the quality of a given channel. These variables are numerous, and can  
30 range from electro-magnet interference to a physical break in an optical fiber. A physical break in an optical fiber severs the communication link and cannot be avoided by switching channels, however, a channel which is electrically

interfered with can be avoided until the interference is gone. After the interference is gone the channel could be used again.

Referring to Figure 28, a channel monitoring method is used to detect and avoid use of corrupted channels. A channel monitor 296 is used to  
5 receive events from board support software 298 and update a channel quality table 300 in a local database. The monitor 296 also sends messages to a fault isolator 302 and to channel allocator 304 for allocation or reallocation. The basic input to the channel monitor is parity errors which are available from  
10 hardware per the upstream DS0+ channels; the DS0+ channels being 10-bit channels with one of the bits being a parity or data integrity bit inserted in the channel as previously discussed. The parity error information on a particular channel is used as raw data which is sampled and integrated over time to arrive at a quality status for that channel.

Parity errors are integrated using two time frames for each of the  
15 different service types including POTS, ISDN, DDS, and DS1, to determine channel status. The first integration routine is based on a short integration time of one second for all service types. The second routine, long integration, is service dependent, as bit error rate requirements for various services require differing integration times and monitoring periods as seen in Table 3. These  
20 two methods are described below.

Referring to Figure 29A, 29B, and 29C, the basic short integration operation is described. When a parity error of a channel is detected by the CXMU 56, a parity interrupt is disabled by setting the interrupt priority level  
25 above that of the parity interrupt (Figure 29A). If a modem alarm is received which indicates a received signal failure, parity errors will be ignored until the failure condition ends. Thus, some failure conditions will supersede parity error monitoring. Such alarm conditions may include loss of signal, modem failure, and loss of synchronization. If a modem alarm is not active, a parity count table is updated and an error timer event as shown in Figure 29B is  
30 enabled.

When the error timer event is enabled, the channel monitor 296 enters a mode wherein parity error registers of the CXMU 56 are read every 10

milliseconds and error counts are summarized after a one second monitoring period. Generally, the error counts are used to update the channel quality database and determine which (if any) channels require re-allocation. The channel quality table 300 of the database contains an ongoing record of each channel. The table organizes the history of the channels in categories such as:

5 current ISU assigned to the channel, start of monitoring, end of monitoring, total error, errors in last day, in last week and in last 30 days, number of seconds since last error, severe errors in last day, in last week and in last 30 days, and current service type, such as ISDN, assigned to the channel.

10 As indicated in Figure 29A, after the parity interrupt is disabled and no active alarm exists, the parity counts are updated and the timer event is enabled. The timer event (Figure 29B), as indicated above, includes a one second loop where the errors are monitored. As shown in Figure 29B, if the one second loop has not elapsed, the error counts are continued to be updated.

15 When the second has elapsed, the errors are summarized. If the summarized errors over the one second period exceed an allowed amount indicating that an allocated channel is corrupted or bad, as described below, channel allocator 304 is notified and ISU transmission is reallocated to a different channel. As shown in Figure 29C, when the reallocation has been completed, the interrupt

20 priority is lowered below parity so that channel monitoring continues and the channel quality database is updated concerning the actions taken. The reallocation task may be accomplished as a separate task from the error timer task or performed in conjunction with that task. For example, the reallocator 304 may be part of channel monitor 296.

25 As shown in Figure 29D in an alternate embodiment of the error timer task of Figure 29B, channels can be determined to be bad before the one second has elapsed. This allows the channels that are determined to be corrupted during the initial portion of a one second interval to be quickly identified and reallocated without waiting for the entire one second to elapse.

30 Instead of reallocation, the power level for transmission by the ISU may be increased to overcome the ingress on the channel. However, if the power level on one channel is increased, the power level of at least one other

channel must be decreased as the overall power level must be kept substantially constant.

If all channels are determined bad, the fault isolator 302 is notified indicating the probability that a critical failure is present, such as a fiber  
5 break. If the summarized errors over the one second period do not exceed an allowed amount indicating that the allocated channel is not corrupted, the interrupt priority is lowered below parity and the error timer event is disabled. Such event is then ended and the channels once again are monitored for parity errors per Figure 29A.

10 Two issues presented by periodic parity monitoring as described above must be addressed in order to estimate the bit error rate corresponding to the observed count of parity errors in a monitoring period of one second to determine if a channel is corrupted. The first is the nature of parity itself. Accepted practice for data formats using block error detection assumes that an  
15 errored block represents one bit of error, even though the error actually represents a large number of data bits. Due to the nature of the data transport system, errors injected into modulated data are expected to randomize the data. This means that the average errored frame will consist of four (4) errored data bits (excluding the ninth bit). Since parity detects only odd bit  
20 errors, half of all errored frames are not detected by parity. Therefore, each parity (frame) error induced by transport interference represents an average of 8 (data) bits of error. Second, each monitoring parity error represents 80 frames of data (10 ms/125  $\mu$ s). Since the parity error is latched, all errors will be detected, but multiple errors will be detected as one error.

25 The bit error rate (BER) used as a basis for determining when to reallocate a channel has been chosen as  $10^{-3}$ . Therefore, the acceptable number of parity errors in a one second interval that do not exceed  $10^{-3}$  must be determined. To establish the acceptable parity errors, the probable number of frame errors represented by each observed (monitored) parity error must be  
30 predicted. Given the number of monitored parity errors, the probable number of frame errors per monitored parity error, and the number of bit errors represented by a frame (parity) error, a probable bit error rate can be derived.

A statistical technique is used and the following assumptions are made:

1. Errors have a Poisson distribution, and
2. If the number of monitored parity errors is small ( $< 10$ ) with respect to the total number of "samples" (100), the monitored parity error rate (MPER) reflects the mean frame error rate (FER).

5 Since a monitored parity error (MPE) represents 80 frames, assumption 2 implies that the number of frame errors (FEs) "behind" each parity error is equal to 80 MPER. That is, for 100 parity samples at 10 ms per sample, the mean number of frame errors per parity error is equal to 0.8 times the count of MPEs in one second. For example, if 3 MPEs are observed in a one second period, the mean number of FEs for each MPE is 2.4. Multiplying the desired bit error rate times the sample size and dividing by the bit errors per frame error yields the equivalent number of frame errors in the sample. The number of FEs is also equal to the product of the number of MPEs and the number of FEs per MPE. Given the desired BER, a solution set for the following equation can be determined.

$$(MPE \frac{FE}{MPE}) = 0.8MPE$$

20

The Poisson distribution, as follows, is used to compute the probability of a given number of FEs represented by a MPE ( $\chi$ ), and assumption 2. above, is used to arrive at the mean number of FEs per MPE ( $\mu$ ).

25

$$P(x) = \frac{e^{-\mu} \mu^x}{x!}$$

Since the desired bit error rate is a maximum, the Poisson equation is applied successively with values for  $\chi$  of 0 up to the maximum number. The sum of these probabilities is the probability that no more than  $\chi$  frame errors occurred for each monitored parity error.

The results for a bit error rate of  $10^{-3}$  and bit errors per frame error of 1 and 8 are shown in Table 2.

Table 2: Bit Error Rate Probability

	Bit Errors per Frame Error	Monitored Parity Errors	Maximum Frame Errors/ Monitored Parity Error (x)	Average Frame Errors/ Monitored Parity Error ( $\mu$ )	Probability of BER $< 10^{-3}$
10					
		2	4	1.6	98%
15					
	8	3	3	2.4	78%
20		4	2	3.2	38%
		8	8	6.4	80%
25	1	9	7	7.2	56%
		10	7	8.0	45%

Using this technique, a value of 4 monitored parity errors detected during a one second integration was determined as the threshold to reallocate service of an ISU to a new channel. This result is arrived at by assuming a worst case of 8 bit errors per frame error, but a probability of only 38% that the bit error rate is better than  $10^{-3}$ . The product of the bit errors per frame, monitored parity errors and maximum frame errors per monitored parity error must be 64, for a bit error rate of  $10^{-3}$  (64 errors in 64k bits). Therefore, when the sampling of the parity errors in the error timer event is four or greater, the channel allocator is notified of a corrupted channel. If the sampled monitored parity errors is less than 4, the interrupt priority is lowered below parity and the error timer event is disabled, ending the timer error event



and the channels are then monitored as shown in the flow diagram of 27A.

The following is a description of the long integration operation performed by the background monitor routine (Figure 30) of the channel monitor 296. The background monitor routine is used to ensure quality integrity for channels requiring greater quality than the short integration  $10^{-3}$  bit error rate. As the flow diagram shows in Figure 30, the background monitor routine operates over a specified time for each service type, updates the channel quality database table 300, clears the background count, determines if the integrated errors exceed the allowable limits determined for each service type, and notifies the channel allocator 304 of bad channels as needed.

In operation, on one second intervals, the background monitor updates the channel quality database table. Updating the channel quality data table has two purposes. The first purpose is to adjust the bit error rate and number of errored seconds data of error free channels to reflect their increasing quality. The second purpose is to integrate intermittent errors on monitored channels which are experiencing error levels too low to result in short integration time reallocation (less than 4 parity errors/second). Channels in this category have their BER and numbers of errored seconds data adjusted, and based on the data, may be re-allocated. This is known as long integration time re-allocation, and the default criteria for long integration time re-allocation for each service type are shown as follows:

Table 3

Service type:	Maximum BER:	Integration Time:	Errored seconds	Monitoring Period:
POTS	$10^{-3}$	1 second		
ISDN	$10^{-6}$	157 seconds	8 %	1 hour
DDS	$10^{-7}$	157 seconds	0.5 %	1 hour
DS1	$10^{-9}$	15.625 seconds	0.04 %	7 hours

Because POTS service does not require higher quality than  $10^{-3}$ , corrupted channels are sufficiently eliminated using the short integration technique and

long integration is not required.

As one example of long integration for a service type, the background monitor shall be described with reference to a channel used for ISDN transport. Maximum bit error rate for the channel may be  $10^{-6}$ , the number of seconds utilized for integration time is 157, the maximum number of errored seconds allowable is 8% of the 157 seconds, and the monitoring period is one hour. Therefore, if the summation of errored seconds is greater than 8% over the 157 seconds in any one hour monitoring period, the channel allocator 304 is notified of a bad channel for ISDN transport.

Unallocated or unused channels, but initialized and activated, whether used for reallocation for non-concentration services such as TR-8 or used for allocation or reallocation for concentration services such as TR-303, must also be monitored to insure that they are not bad, thereby reducing the chance that a bad channel will be allocated or reallocated to an ISU 100. To monitor unallocated channels, channel monitor 304 uses a backup manager routine (Figure 31) to set up unallocated channels in a loop in order to accumulate error data used to make allocation or re-allocation decisions. When an unallocated channel experiences errors, it will not be allocated to an ISU 100 for one hour. After the channel has remained idle (unallocated) for one hour, the channel monitor places the channel in a loop back mode to see if the channel has improved. In loop back mode, the CXMU 56 commands an initialized and activated ISU 100 to transmit a message on the channel long enough to perform short or long integration on the parity errors as appropriate. In the loop back mode, it can be determined whether the previously corrupted channel has improved over time and the channel quality database is updated accordingly. When not in the loop back mode, such channels can be powered down.

As described above, the channel quality database includes information to allow a reallocation or allocation to be made in such a manner that the channel used for allocation or reallocation is not corrupted. In addition, the information of the channel quality database can be utilized to rank the unallocated channels as for quality such that they can be allocated effectively.

For example, a channel may be good enough for POTS and not good enough for ISDN. Another additional channel may be good enough for both. The additional channel may be held for ISDN transmission and not used for POTS. In addition, a particular standby channel of very good quality may be set aside  
5 such that when ingress is considerably high, one channel is always available to be switched to.

In addition, an estimate of signal to noise ratio can also be determined for both unallocated and allocated channels utilizing the equalizer 214 of the MCC modem 82 upstream receiver architecture as shown in Figure 15. As  
10 described earlier, the equalizer was previously utilized to determine whether a channel was idle such that it could be allocated. During operation of the equalizer, as previously described, an error is generated to update the equalizer coefficients. The magnitude of the error can be mapped into an estimate of signal to noise ratio (SNR) by signal to noise monitor 305 (Figure 15).  
15 Likewise, an unused channel should have no signal in the band. Therefore, by looking at the variance of the detected signal within the unused FFT bin, an estimate of signal to noise ratio can be determined. As the signal to noise ratio estimate is directly related to a probable bit error rate, such probable bit error rate can be utilized for channel monitoring in order to determine whether  
20 a bad or good channel exists.

Therefore, for reallocation for nonconcentration services such as TR-8 services, reallocation can be performed to unallocated channels with such unallocated channels monitored through the loopback mode or by SNR estimation by utilization of the equalizer. Likewise, allocation or reallocation  
25 for concentration services such as TR-303 services can be made to unallocated channels based upon the quality of such unallocated channels as determined by the SNR estimation by use of the equalizer.

With respect to channel allocation, a channel allocator routine for channel allocator 304 examines the channel quality database table to determine  
30 which DS0+ channels to allocate to an ISU 100 for a requested service. The channel allocator also checks the status of the ISU and channel units to verify in-service status and proper type for the requested service. The channel

allocator attempts to maintain an optimal distribution of the bandwidth at the ISUs to permit flexibility for channel reallocation. Since it is preferred that ISUs 100, at least HISUs, be able to access only a portion of the RF band at any given time, the channel allocator must distribute channel usage over the  
5 ISUs so as to not overload any one section of bandwidth and avoid reallocating in-service channels to make room for additional channels.

The process used by the channel allocator 304 is to allocate equal numbers of each ISU type to each band of channels of the 6 MHz spectrum. If necessary, in use channels on an ISU can be moved to a new band, if the  
10 current ISU band is full and a new service is assigned to the ISU. Likewise, if a channel used by an ISU in one band gets corrupted, the ISU can be reallocated to a channel in another subband or band of channels. Remember that the distributed IOC channels continue to allow communication between the HDT 12 and the HISUs as an HISU always sees one of the IOC channels  
15 distributed throughout the spectrum. Generally, channels with the longest low-error rate history will be used first. In this way, channels which have been marked bad and subsequently reallocated for monitoring purposes will be used last, since their histories will be shorter than channels which have been operating in a low error condition for a longer period.

20

#### Second Embodiment of Telephony Transport System

A second embodiment of an OFDM telephony transport system, referring to Figures 24-27 shall be described. The 6 MHz spectrum allocation is shown in Figure 24. The 6 MHz bandwidth is divided into nine channel  
25 bands corresponding to the nine individual modems 226 (Figure 25). It will be recognized by one skilled in the art that less modems could be used by combining identical operations. Each of the channel bands includes 32 channels modulated with a quadrature 32-ary format (32-QAM) having five bits per symbol. A single channel is allocated to support transfer of  
30 operations and control data (IOC control data) for communication between an HDT 12 and ISUs 100. This channel uses BPSK modulation.

The transport architecture shall first be described with respect to

downstream transmission and then with respect to upstream transmission.

Referring to Figure 25, the MCC modem 82 architecture of the HDT 12 will be described. In the downstream direction, serial telephony information and control data is applied from the CXMC 80 through the serial interface 236.

- 5 The serial data is demultiplexed by demultiplexer 238 into parallel data streams. These data streams are submitted to a bank of 32 channel modems 226 which perform symbol mapping and fast fourier transform (FFT) functions. The 32 channel modems output time domain samples which pass through a set of mixers 240 that are driven by the synthesizer 230. The
- 10 mixers 240 create a set of frequency bands that are orthogonal, and each band is then filtered through the filter/combiner 228. The aggregate output of the filter/combiner 228 is then upconverted by synthesizer 242 and mixer 241 to the final transmitter frequency. The signal is then filtered by filter 232, amplified by amplifier 234, and filtered again by filter 232 to take off any
- 15 noise content. The signal is then coupled onto the HFC distribution network via telephony transmitter 14.

- On the downstream end of the HFC distribution network 11, an ISU 100 includes a subscriber modem 258 as shown in Figure 26. The downstream signals are received from the ODN 18 through the coax leg 30,
- 20 and are filtered by filter 260 which provides selectivity for the entire 6 MHz band. Then the signal is split into two parts. The first part provides control data and timing information to synchronize clocks for the system. The second part provides the telephony data. With the control data received separately from the telephony data, this is referred to as previously described above as an
- 25 out of band ISU. The out of band control channel which is BPSK modulated is split off and mixed to baseband by mixer 262. The signal is then filtered by filter 263 and passed through an automatic gain control stage 264 and a Costas loop 266 where carrier phase is recovered. The signal that results is passed into a timing loop 268 so timing can be recovered for the entire
- 30 modem. The IOC control data, which is a byproduct of the Costas loop, is passed into the 32 channel OFDM modem 224 of the ISU 100. The second part of the downstream OFDM waveform is mixed to base band by mixer 270

and associated synthesizer 272. The output of the mixer 270 is filtered by filter 273 and goes through a gain control stage 274 to prepare it for reception. It then passes into the 32 channel OFDM modem 224.

Referring to Figure 27, the IOC control data is hard limited through function block 276 and provided to microprocessor 226. The OFDM telephony data is passed through an analog to digital converter 278 and input to a first-in first-out buffer 280 where it is stored. When a sufficient amount of information is stored, it is accepted by the microprocessor 226 where the remainder of the demodulation process, including application of an FFT, takes place. The microprocessor 226 provides the received data to the rest of the system through the receive data and receive data clock interface. The fast fourier transform (FFT) engine 282 is implemented off the microprocessor. However, one skilled in the art will recognize that the FFT 282 could be done by the microprocessor 226.

In the upstream direction, data enters the 32 channel OFDM modem 224 through the transmit data ports and is converted to symbols by the microprocessor 226. These symbols pass through the FFT engine 282, and the resulting time domain waveform, including guard samples, goes through a complex mixer 284. The complex mixer 284 mixes the waveform up in frequency and the signal is then passed through a random access memory digital to analog converter 286 (RAM DAC). The RAM DAC contains some RAM to store up samples before being applied to the analog portion of the ISU upstream transmitter (Figure 26). Referring to Figure 26, the OFDM output for upstream transport is filtered by filter 288. The waveform then passes through mixer 290 where it is mixed under control of synthesizer 291 up to the transmit frequency. The signal is then passed through a processor gain control 292 so that amplitude leveling can take place in the upstream path. The upstream signal is finally passed through a 6 MHz filter 294 as a final selectivity before upstream transmission on the coaxial leg 30 to the ODN 18.

In the upstream direction at the HDT 12 side, a signal received on the coax from the telephony receiver 16 is filtered by filter 244 and amplified by

amplifier 246. The received signal, which is orthogonally frequency division multiplexed, is mixed to baseband by bank of mixers 248 and associated synthesizer 250. Each output of the mixers 248 is then filtered by baseband filter bank 252 and each output time domain waveform is sent then to a  
5 demodulator of the 32 channel OFDM modems 226. The signals pass through a FFT and the symbols are mapped back into bits. The bits are then multiplexed together by multiplexer 254 and applied to CXMC 56 through the other serial interface 256.

As shown in this embodiment, the ISU is an out of band ISU as  
10 utilization of separate receivers for control data and telephony data is indicative thereof as previously discussed. In addition, the separation of the spectrum into channel bands is further shown. Various other embodiments as contemplated by the accompanying claims of the transport system are possible by building on the embodiments described herein. In one embodiment, an  
15 IOC control channel for at least synchronization information transport, and the telephony service channels or paths are provided into a single format. The IOC link between the HDT 12 and the ISUs 100 may be implemented as four BPSK modulated carriers operating at 16 kbps, yielding a data rate of 64 kbps in total. Each subscriber would implement a simple separate transceiver, like  
20 in the second embodiment, which continuously monitors the service channel assigned to it on the downstream link separately from the telephony channels. This transceiver would require a tuned oscillator to tune to the service IOC channel. Likewise, an IOC channel could be provided for channel bands of the 6 MHz bandwidth and the channel bands may include orthogonal carriers  
25 for telephony data and an IOC channel that is received separately from the reception of the orthogonal carriers.

In another embodiment, instead of 4 BPSK channels, a single 64 kbps IOC channel is provided. This single channel lies on the OFDM frequency structure, although the symbol rate is not compatible with the telephony  
30 symbol rate of OFDM framework. This single wide band signal requires a wider band receiver at the ISU 100 such that the IOC link between the HDT 12 and ISUs is always possible. With single channel support it is possible to

use a fixed reference oscillator that does not have to tune across any part of the band in the subscriber units. However, unlike in the first embodiment where the IOC channels are distributed across the spectrum allowing for narrow band receivers, the power requirements for this embodiment would increase because of the use of the wide band receiver at the ISU 100.

In yet another embodiment, the IOC link may include two IOC channels in each of 32 OFDM channel groups. This increases the number of OFDM carriers to 34 from 32 in each group. Each channel group would consist of 34 OFDM channels and a channel band may contain 8 to 10 channels groups. This approach allows a narrow band receiver to be used to lock to the reference parameters provided by the HDT 12 to utilize an OFDM waveform, but adds the complexity of also having to provide the control or service information in the OFDM data path format. Because the subscriber could tune to any one of the channel groups, the information that is embedded in the extra carriers must also be tracked by the central office. Since the system needs to support a timing acquisition requirement, this embodiment may also require that a synchronization signal be placed off the end of the OFDM waveform.

It is to be understood, however, that even though numerous characteristics of the present invention have been set forth in the foregoing description, together with details of the structure and function of the invention, the disclosure is illustrative and changes in matters of order, shape, size, and arrangement of the parts, and various properties of the operation may be made within the principles of the invention and to the full extent indicated by the broad general meaning of the terms in which the appended claims are expressed.



## WHAT IS CLAIMED IS:

1. A method for monitoring at least one telephony communication n-bit channel wherein one of the bits being a parity bit, the method comprising the steps of:
  - 5 sampling the parity bit of the n-bit channel; and  
deriving a probable bit error rate from the sampling of the parity bit.
2. The method of claim 1, further comprising the step of periodically monitoring and accumulating error data for at least one unallocated telephony  
10 communication channel.
3. The method of claim 1, further comprising the steps of:
  - 15 comparing the probable bit error rate to a pre-determined bit error rate value to determine if the at least one telephony communication n-bit channel is corrupted; and  
re-allocating the at least one telephony communication n-bit channel to an uncorrupted and unallocated telephony communication n-bit channel, if the at least one telephony communication n-bit channel is corrupted.
- 20 4. The method of claim 1 further comprising the steps of:
  - comparing the probable bit error rate to a pre-determined bit error rate value to determine if the at least one telephony communication n-bit channel is corrupted; and  
increasing transmission power of the n-bit channel if the n-bit channel  
25 is corrupted, while maintaining total system power.
5. A method for monitoring at least one telephony communication n-bit channel wherein one of the bits being a parity bit, the method comprising the steps of:
  - 30 sampling the parity bit of the n-bit channel;  
deriving a probable bit error rate from the sampling of the parity bit over a time period; and

comparing the probable bit error rate over the time period to a pre-determined bit error rate value to determine if the n-bit channel is corrupted.

6. The method of claim 5 further comprising the step of re-allocating the communication from the n-bit channel to a different n-bit channel based on the comparison.

7. The method of claim 6 wherein the at least one telephony communication n-bit channel is contained within a band of a plurality of telephony communication n-bit channels, the band being associated with at least one control channel, and further wherein the different n-bit channel is located within the band.

8. The method of claim 6 wherein the at least one telephony communication n-bit channel is contained within a band of a plurality of telephony communication n-bit channels, the band being associated with at least one control channel, and further wherein the different n-bit channel is located in a second band of a plurality of telephony communication n-bit channels having another at least one control channel associated therewith.

9. The method of claim 5 further comprising the step of increasing transmission power of the n-bit channel if the n-bit channel is corrupted, while maintaining total system power.

10. The method of claim 5 further comprising the step of storing the probable bit error rate in a table, wherein the table can be used for allocating future communications on an n-bit channel.

11. The method of claim 5 further comprising the steps of:  
deriving at least one additional probable bit error rate from the sampling of the parity bit over at least one longer time period if the channel is not corrupted; and

comparing the at least one additional probable bit error rate to an additional pre-determined bit error rate value to determine if the n-bit channel is corrupted.

- 5 12. The method of claim 11 wherein the predetermined bit error rate value is for a telephony communication service and the additional predetermined bit error rate value is for an additional telephony communication service.
13. The method of claim 12 wherein one of the telephony communication  
10 services is ISDN.
14. The method of claim 11 further comprising the step of increasing transmission power of the n-bit channel if the n-bit channel is corrupted, while maintaining total system power.
- 15 15. The method of claim 11 further comprising the step of re-allocating the communication from the n-bit channel to a different n-bit channel based on the comparison of the at least one additional probable bit error rate to an additional pre-determined bit error rate value.
- 20 16. A method for monitoring at least one telephony communication n-bit channel wherein one of the bits being a parity bit, the method comprising the steps of:
- 25 sampling the parity bit of the n-bit channel over a first time period;
- deriving a probable bit error rate from the sampling of the parity bit over the first time period;
- comparing the probable bit error rate over the first time period to a pre-determined bit error rate value to determine if the n-bit channel is corrupted; and
- 30 accumulating a probable bit error rate over a plurality of successive time periods if the n-bit channel is not corrupted.

17. The method of claim 16 further comprising the step of comparing the accumulated probable bit error rate over the successive time periods to at least one additional pre-determined bit error rate value to determine if the n-bit channel is corrupted.
- 5
18. The method of claim 17 further comprising the step of re-allocating communication from the n-bit channel to a second n-bit channel if the n-bit channel is corrupted.
- 10
19. The method of claim 17 further comprising the step of increasing transmission power of the n-bit channel if the n-bit channel is corrupted, while maintaining total system power.
- 20.
- 15
20. The method of claim 19 wherein the predetermined bit error rate value is associated with a telephony communication service and the at least one additional predetermined bit error rate value is associated with at least one additional telephony communication service.
- 21.
- 20
21. The method of claim 20 wherein one of the telephony communication services is ISDN.
- 22.
- 25
22. The method of claim 16 further comprising the step of re-allocating communication from the n-bit channel to a second n-bit channel if the n-bit channel is corrupted.
- 23.
23. The method of claim 16 further comprising the step of increasing transmission power of the n-bit channel if the n-bit channel is corrupted, while maintaining total system power.
- 30
24. A method for monitoring at least one telephony communication n-bit channel wherein one of the bits being a parity bit, the method comprising the steps of:

- sampling the parity bit of the n-bit channel;  
deriving a probable bit error rate from the sampling of the parity bit  
over a first time period;  
comparing the probable bit error rate over the first time period to a  
5 first pre-determined bit error rate value to determine if the n-bit channel is  
corrupted;  
deriving a probable bit error rate from the sampling of the parity bit  
over a second time period, the second time period being longer than the first  
time period and running concurrently with the first time period; and  
10 comparing the probable bit error rate over the second time period to a  
second pre-determined bit error rate value to determine if the n-bit channel is  
corrupted.
25. The method of claim 24 further comprising the step of re-allocating the  
15 communication from the n-bit channel to a second n-bit channel if the n-bit  
channel is corrupted.
26. The method of claim 24 further comprising the step of increasing  
transmission power of the n-bit channel if the n-bit channel is corrupted, while  
20 maintaining total system power.
27. The method of claim 24 further comprising the step of storing the  
probable bit error rate in a table, wherein the table can be used for allocating  
future communications on an n-bit channel.  
25
28. A method for monitoring at least one unallocated telephony  
communication channel, the method comprising the steps of:  
periodically monitoring the at least one unallocated telephony  
communication channel;  
30 accumulating error data for the at least one unallocated telephony  
communication channel; and  
allowing the at least one unallocated telephony communication channel

to be allocated based on the error data.

29. The method of claim 28 further comprising the step of re-allocating a telephony communication from a corrupted telephony communication channel  
5 to the at least one unallocated telephony communication channel.

30. The method of claim 28, wherein the periodically monitoring the at least one unallocated telephony communication channel step includes:  
transmitting an n-bit signal, wherein one of the bits being a parity bit,  
10 from the remote transmitter;  
sampling the parity bit of the n-bit channel; and  
deriving a probable bit error rate from the sampled parity bit.

31. The method of claim 28, wherein the unallocated channel is a  
15 powered-down allocated channel, the method further including the steps of:  
powering up a remote transmitter at a remote location on the unallocated channel so that the channel can be monitored; and  
powering down the remote transmitter after the channel is monitored..

20 32. The method of claim 28, further comprising the step of comparing the probable bit error rate to a pre-determined bit error rate value to determine if the channel is corrupt.

33. The method of claim 28 wherein the at least one unallocated telephony  
25 communication channel is one of a plurality of unallocated telephony communication channels, at least a certain number of the unallocated telephony communication channels being monitored; the method including the step of ranking a quality of at least a certain number of the unallocated channels based on such monitoring.

30 34. The method of claim 33 wherein the ranking step includes setting a high quality channel aside as a standby channel.

Figure 1

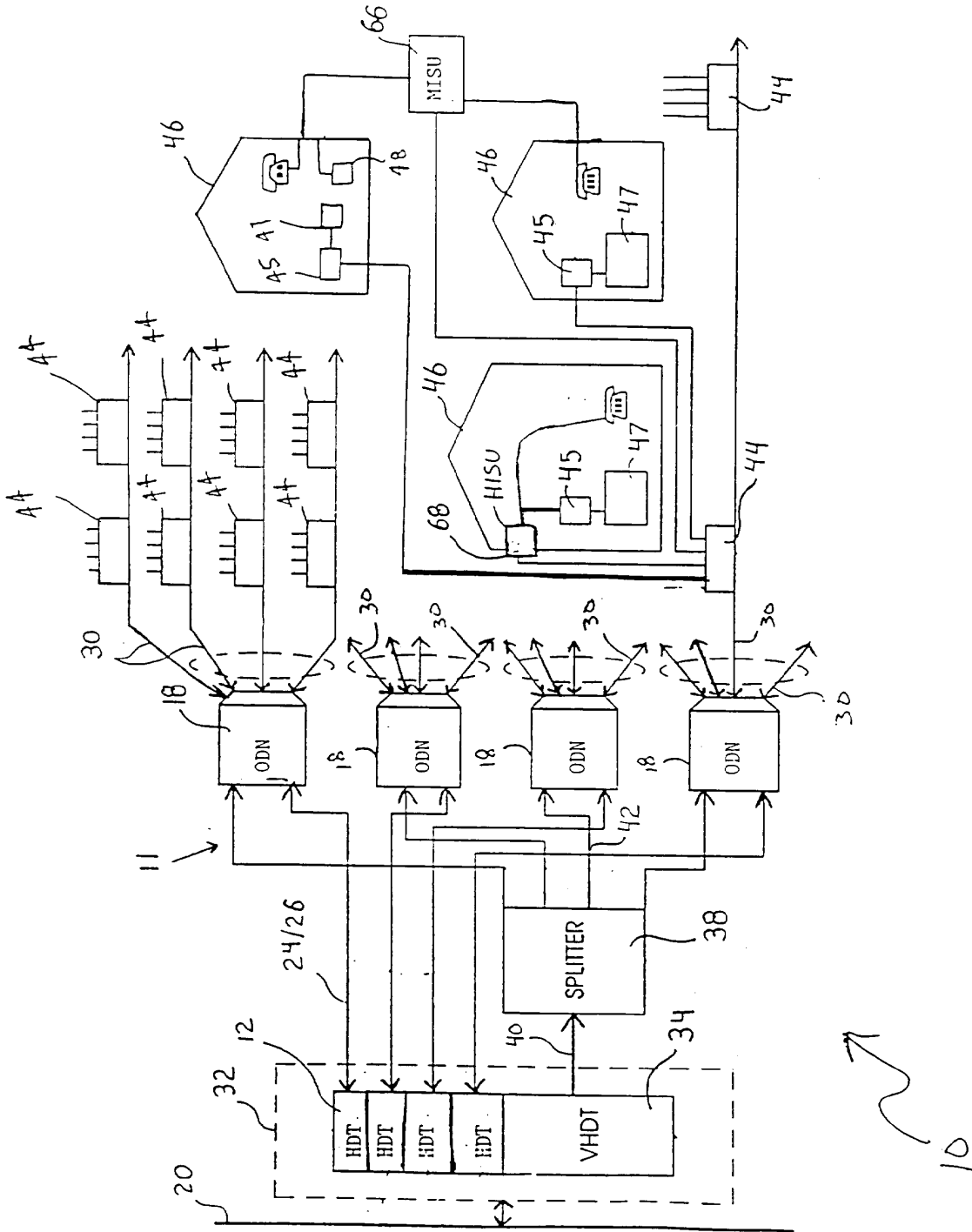

Figure 2

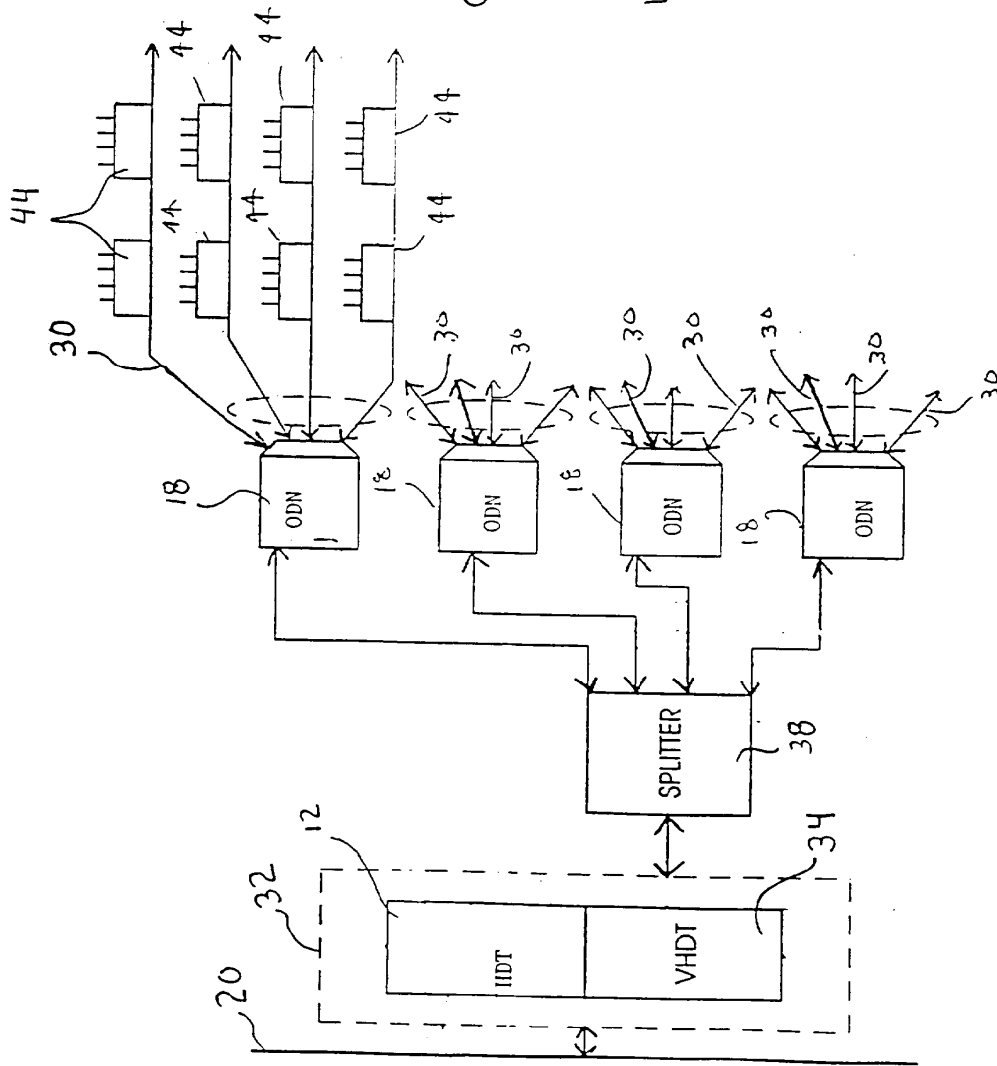
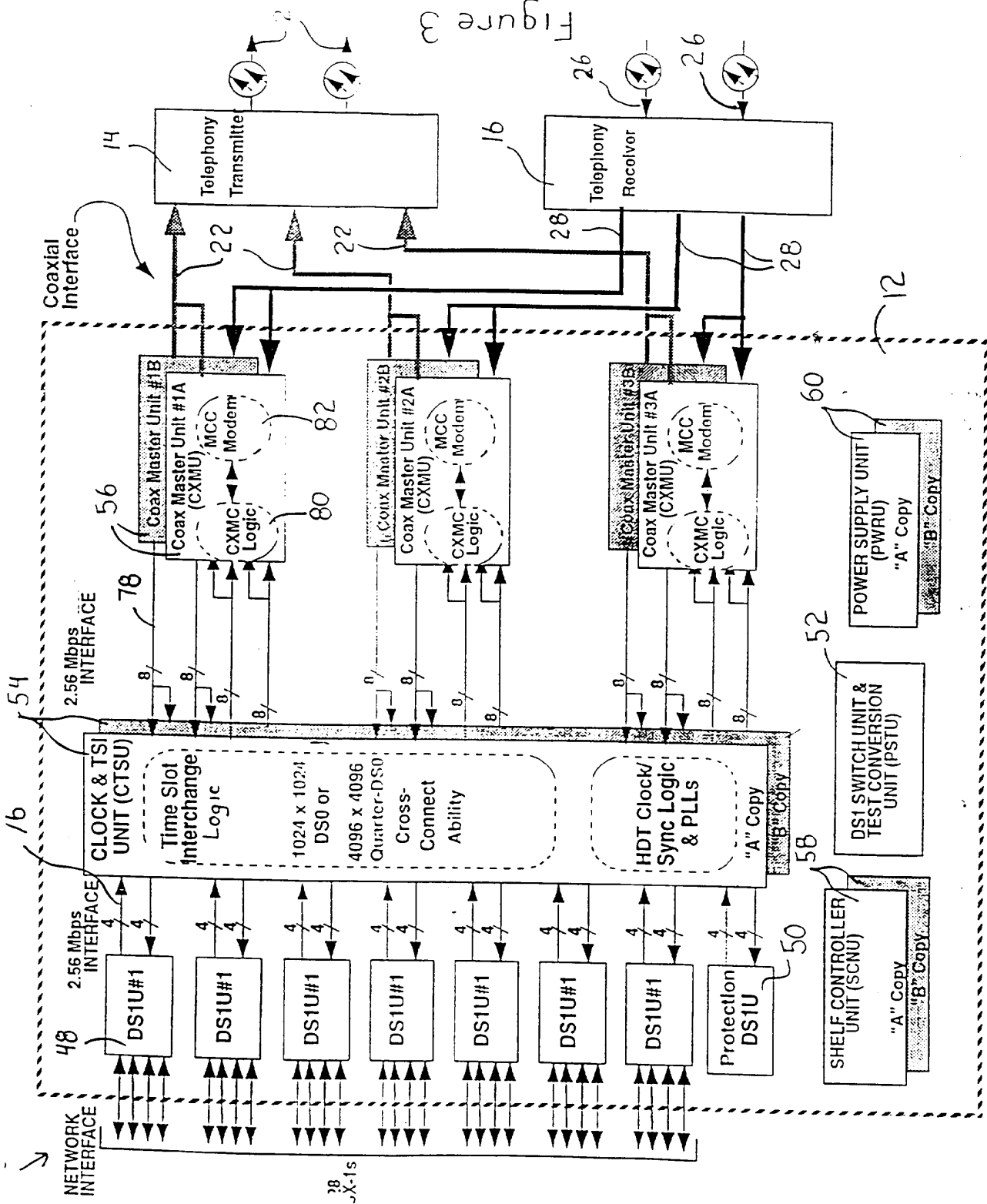
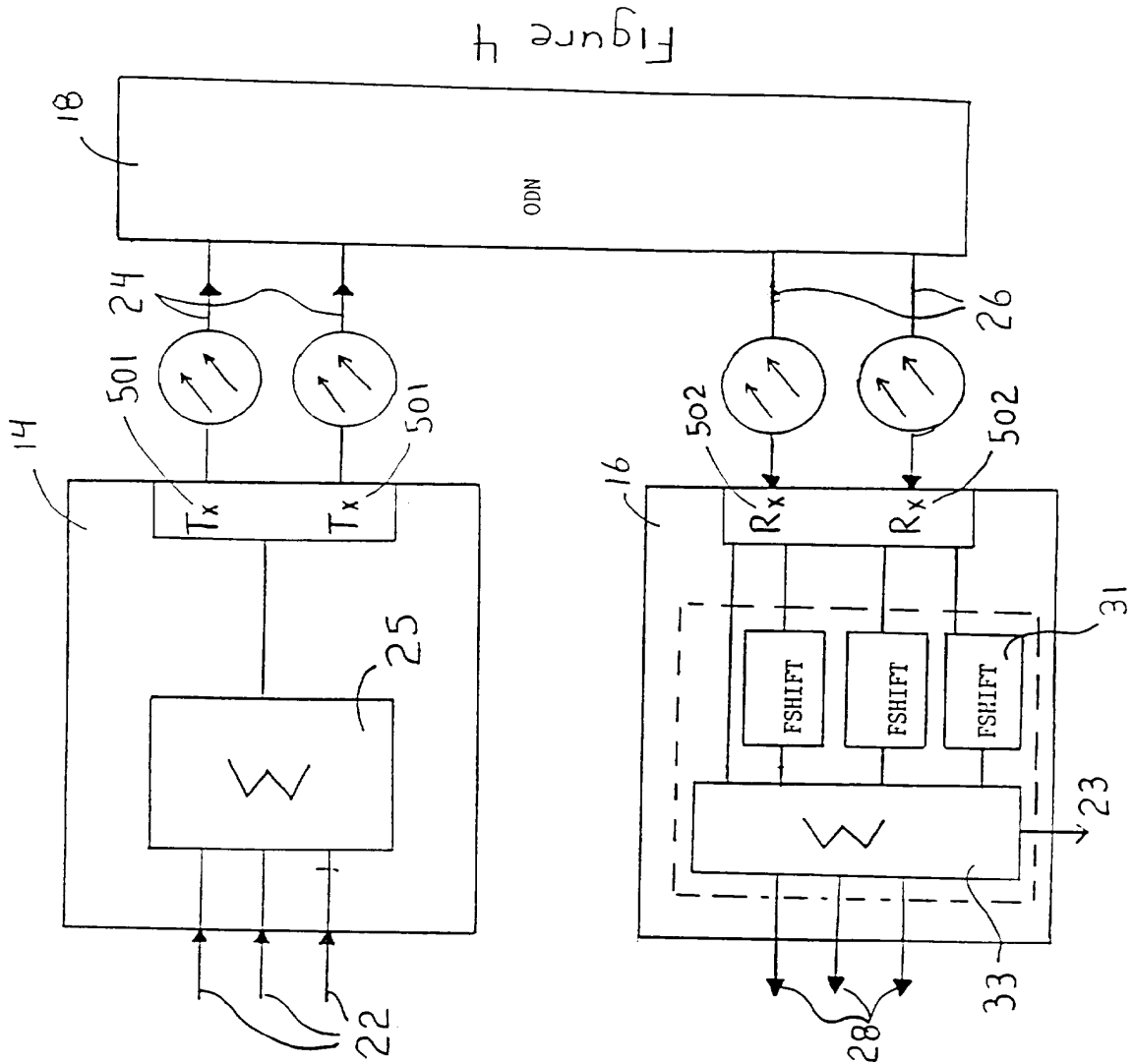



Figure 3





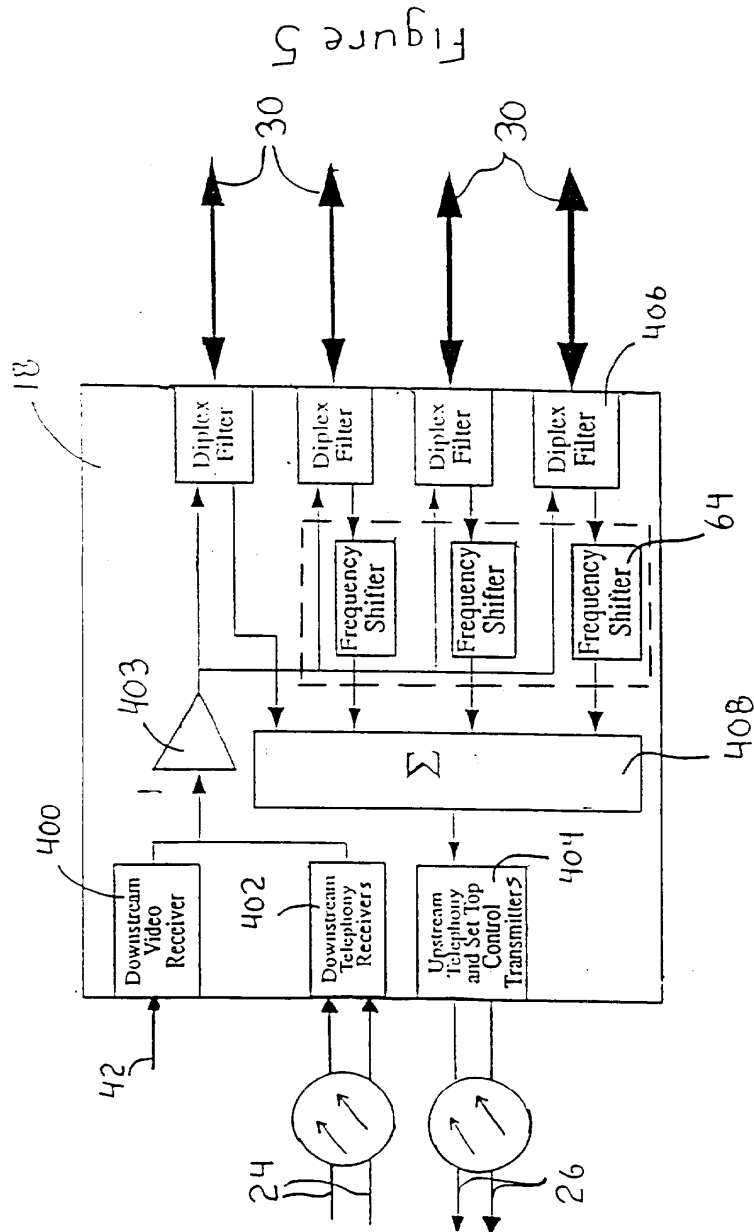

Figure 6

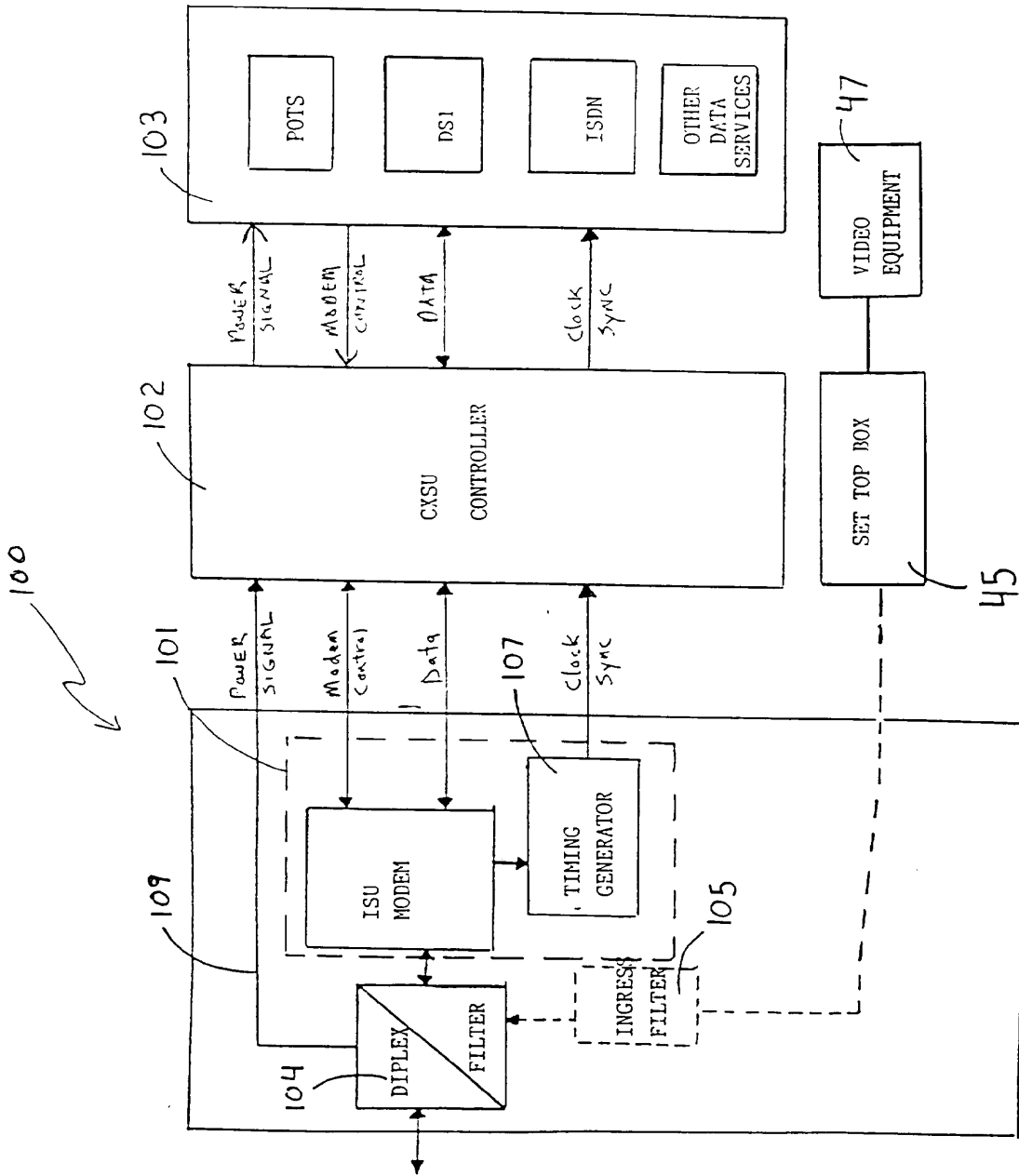

Figure 7A

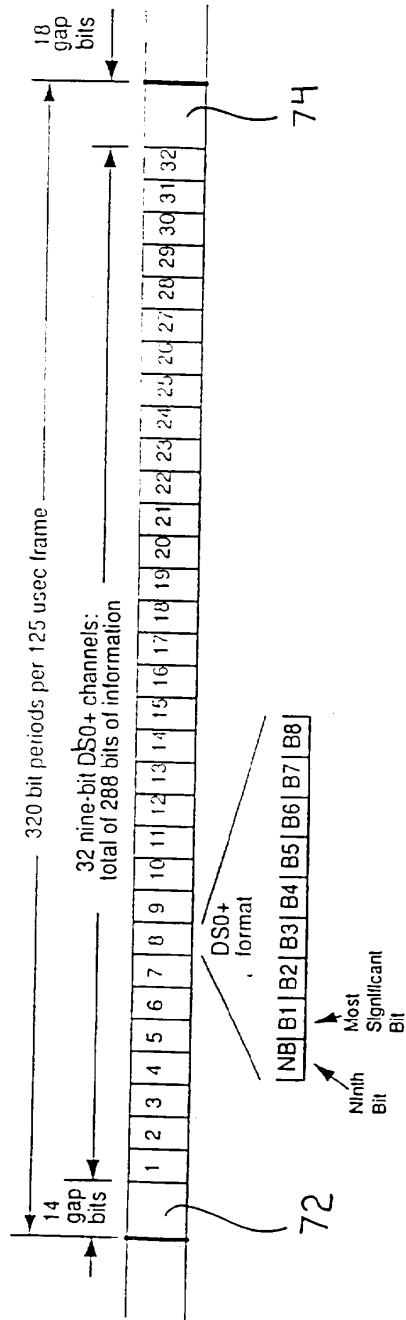

Figure 7B

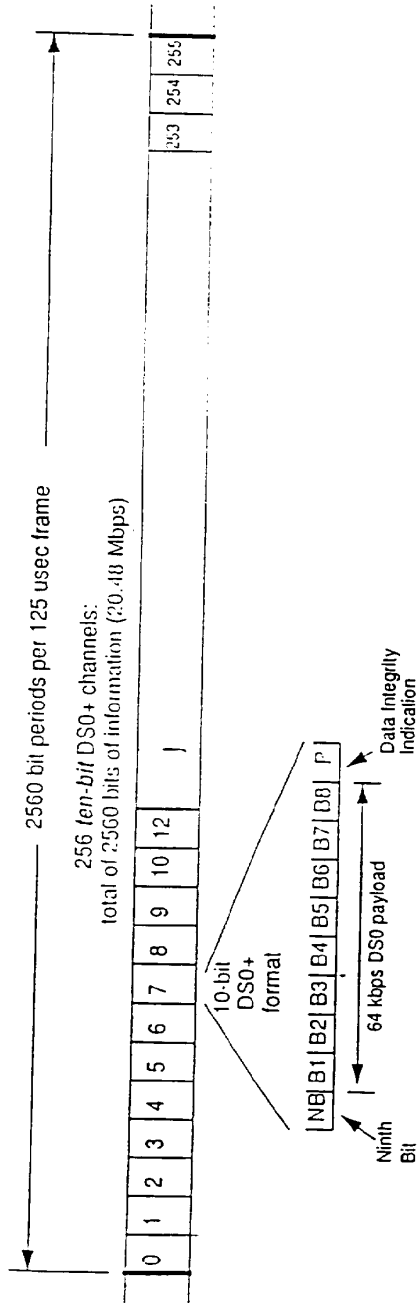
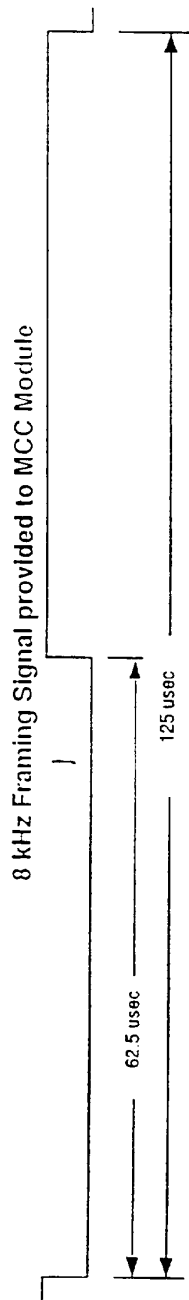

Figure 7c



10/35

Figure 8

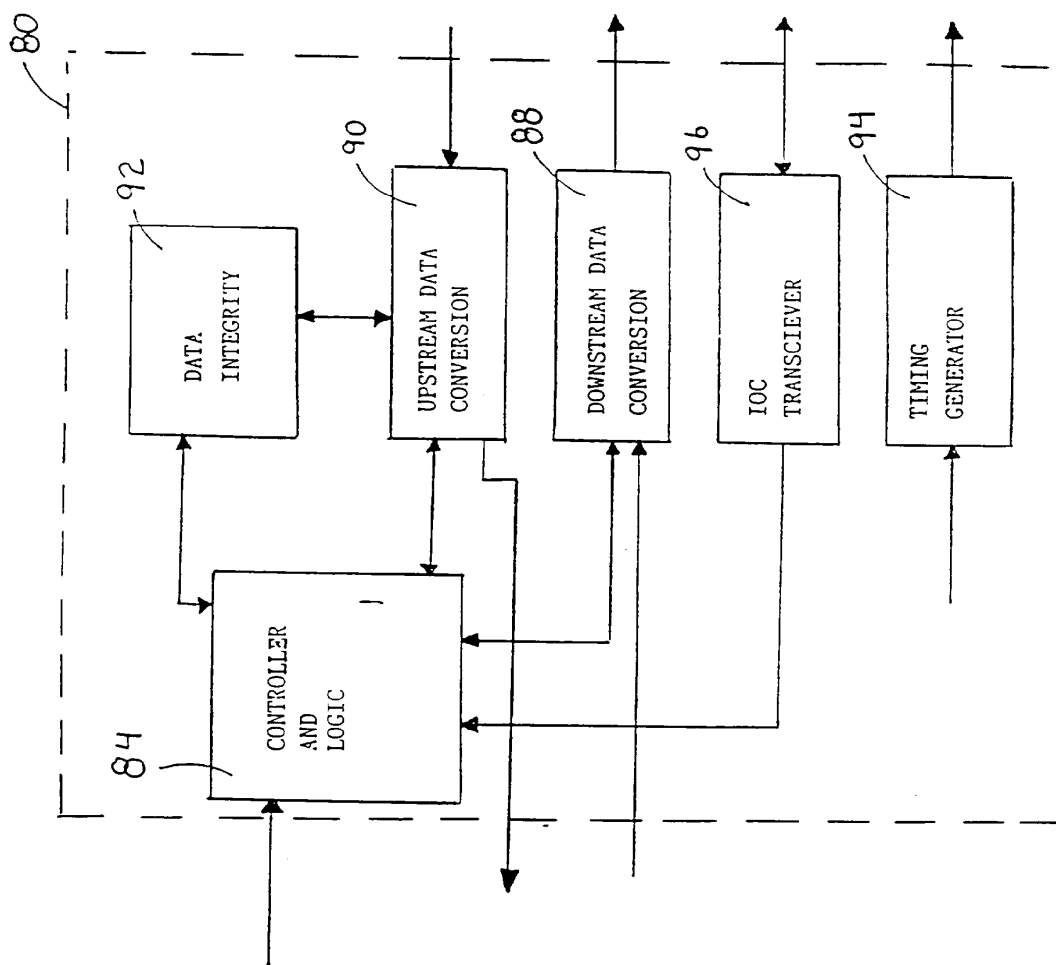



Fig. 9A

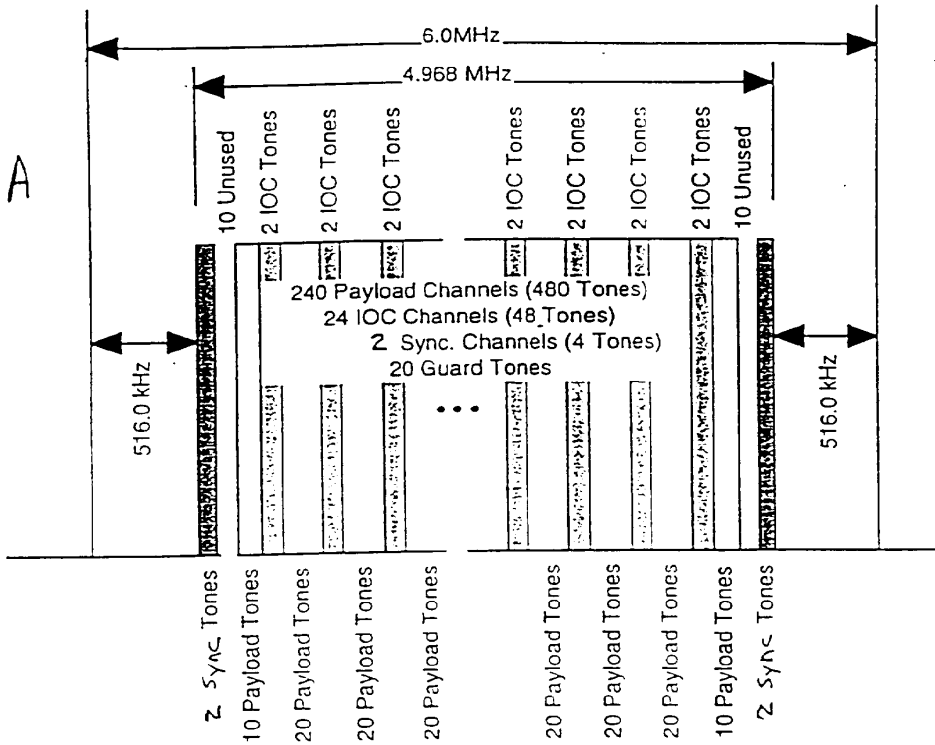
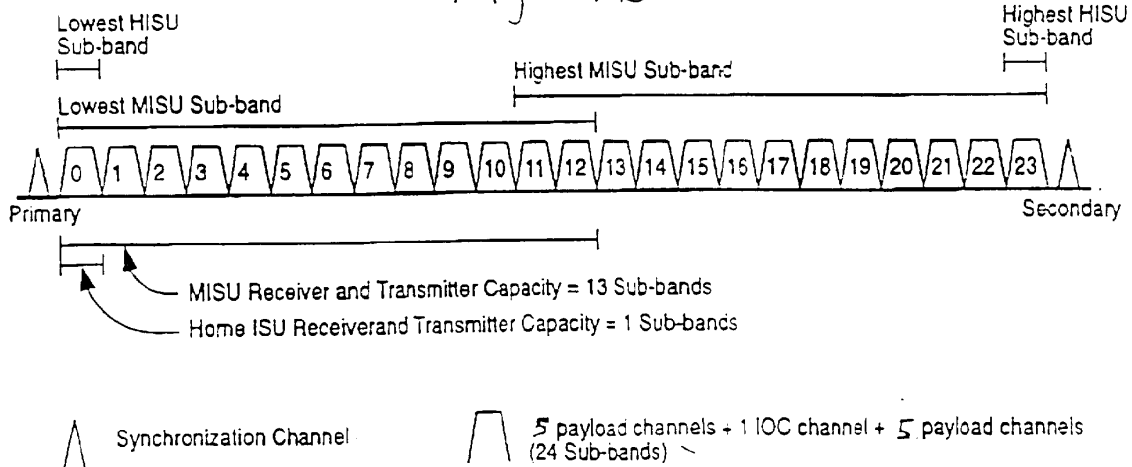

Fig. 9D



12 / 35

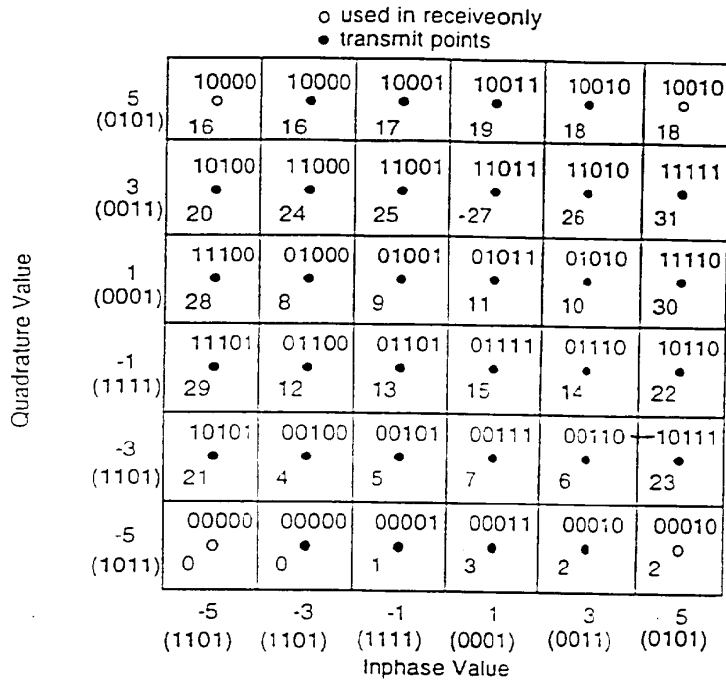

Figure 9B

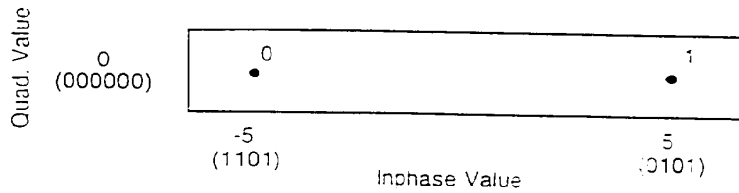

Figure 9C

Figure 10

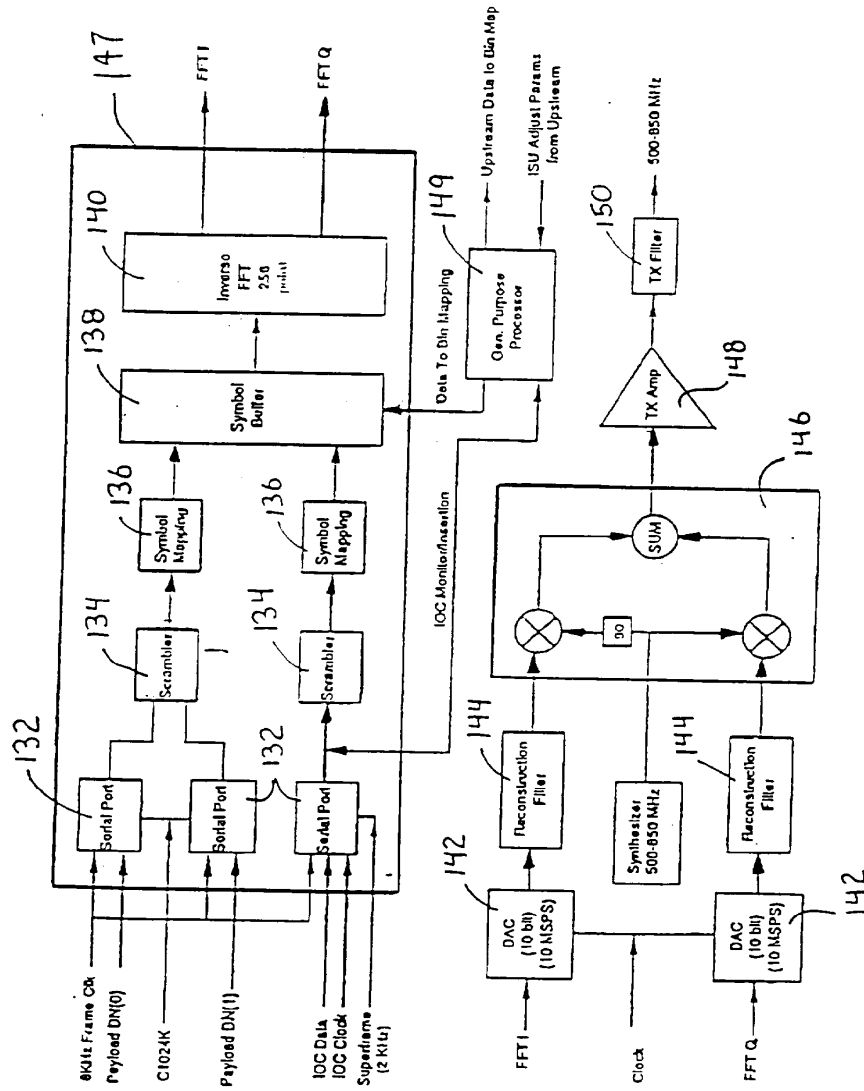

Figure 11

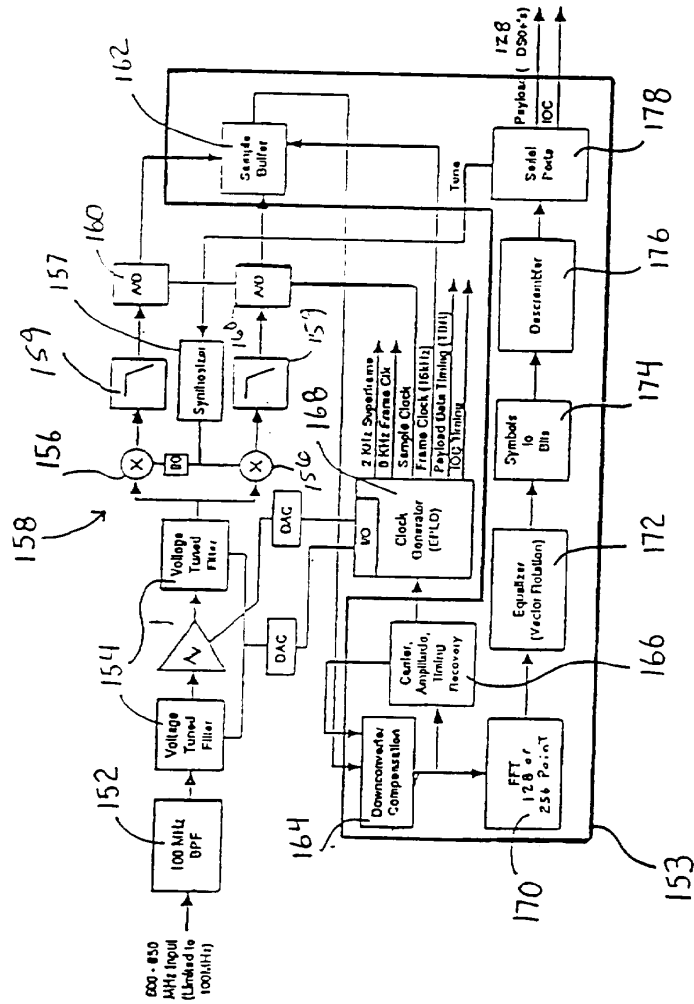
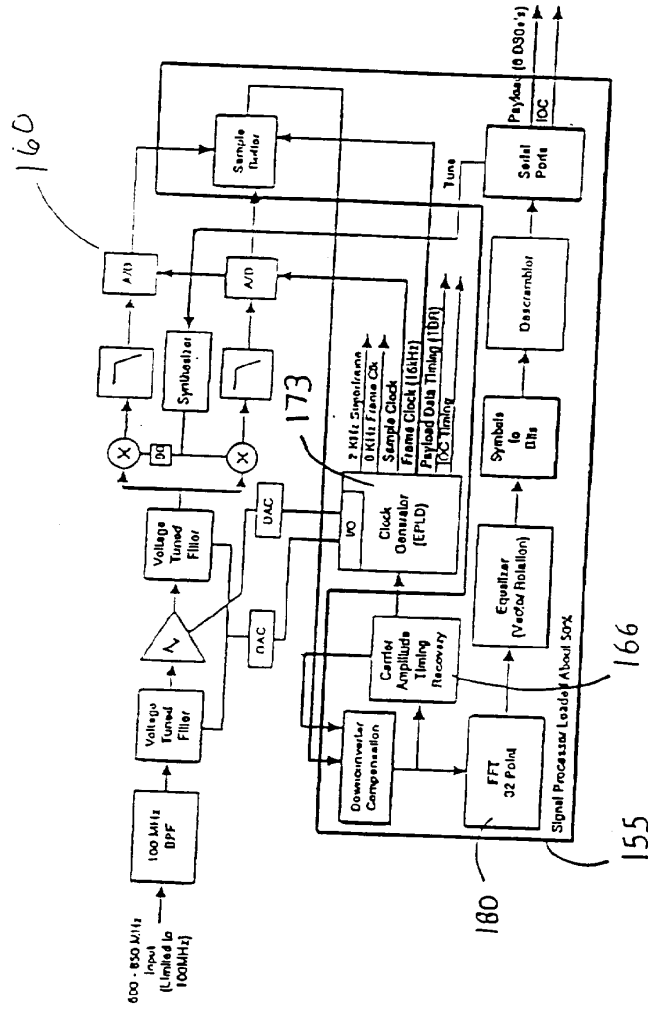
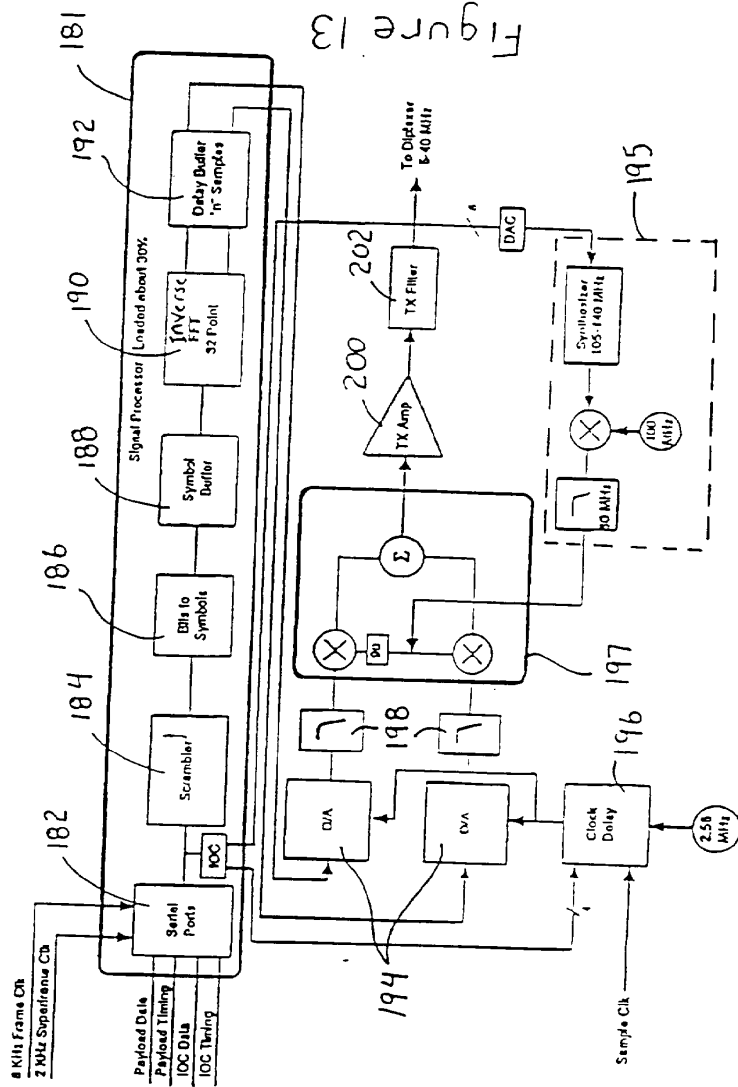
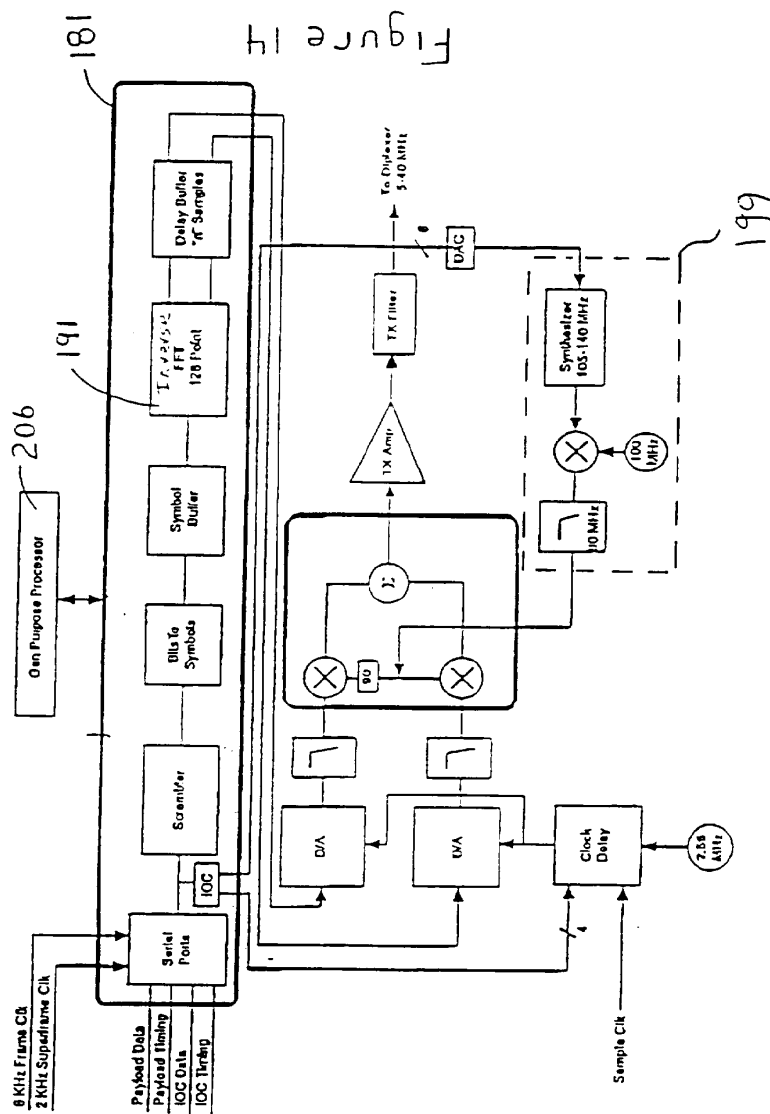
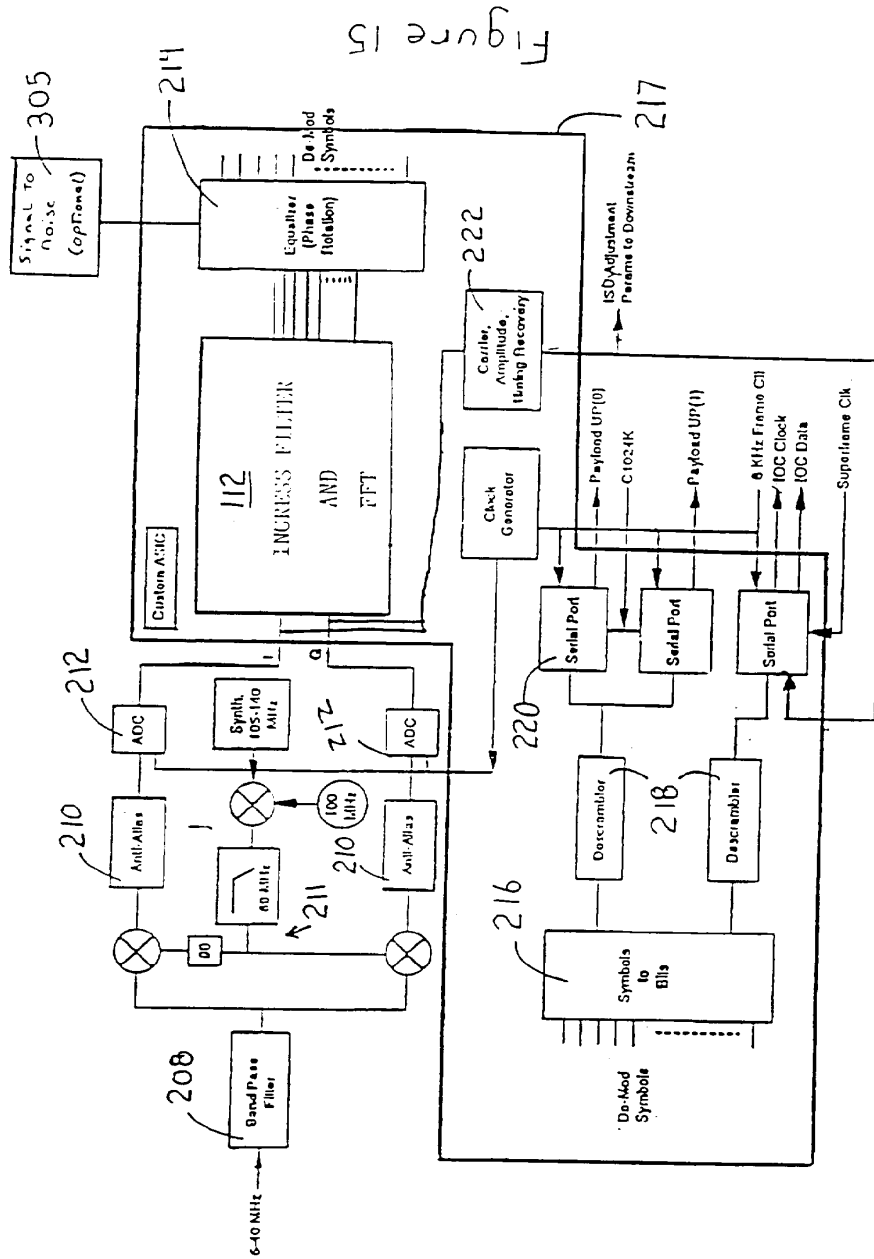

Figure 12











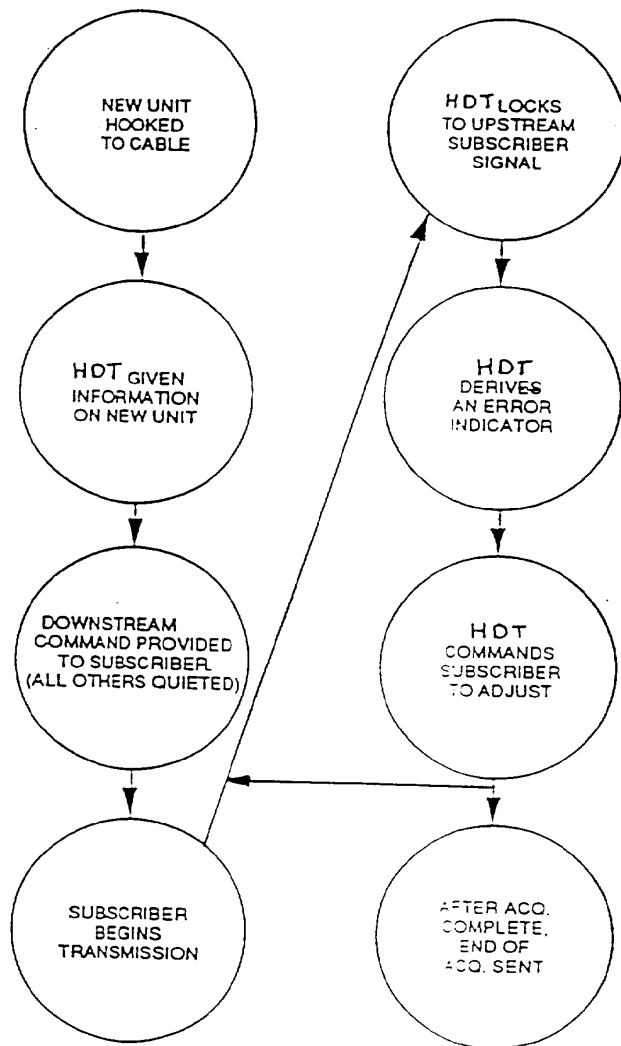

Figure 16

20 / 35

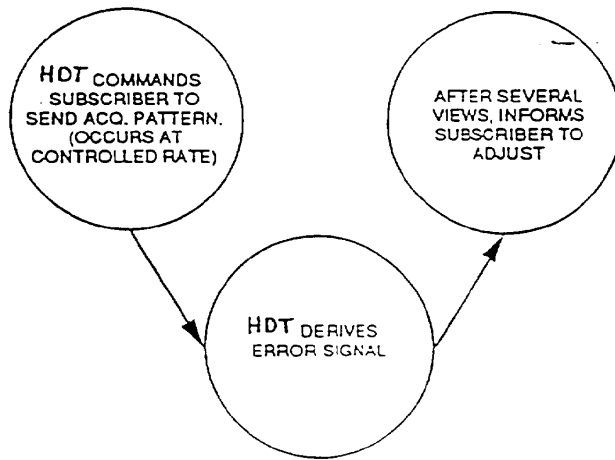

Figure 17

21 / 35

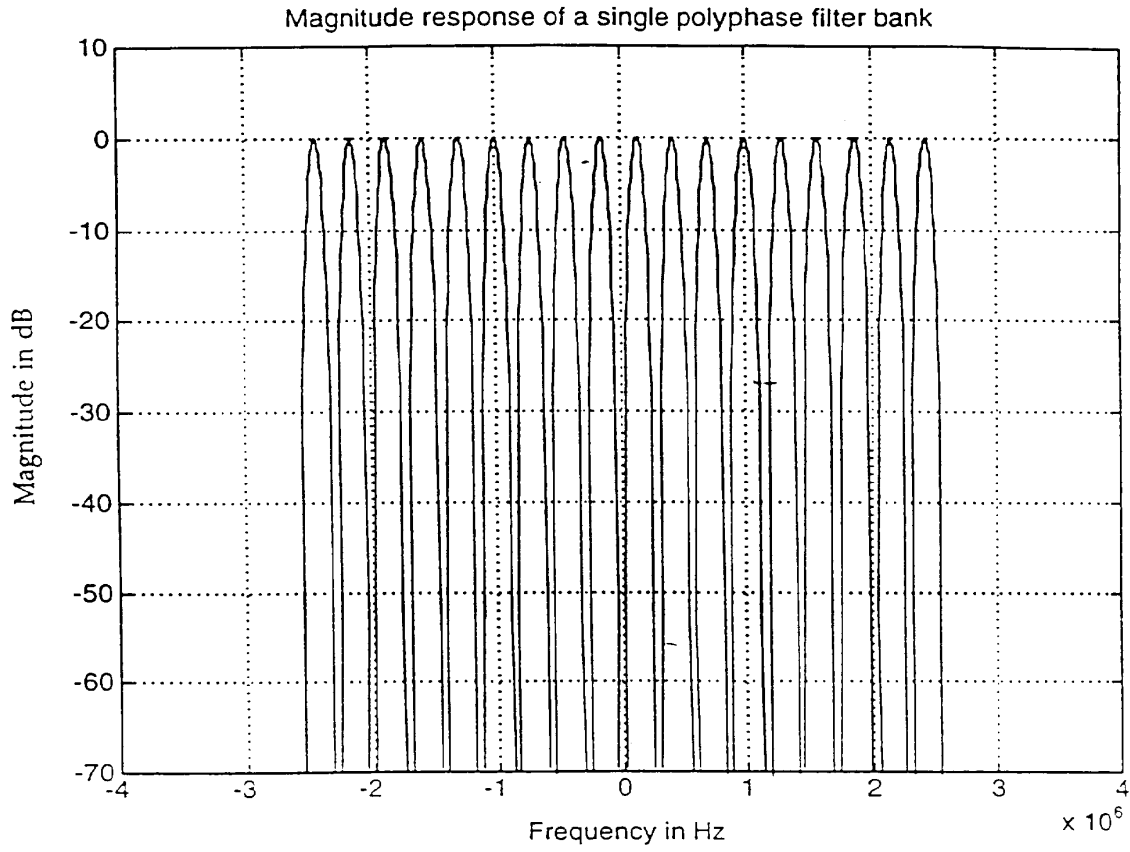

Figure 18

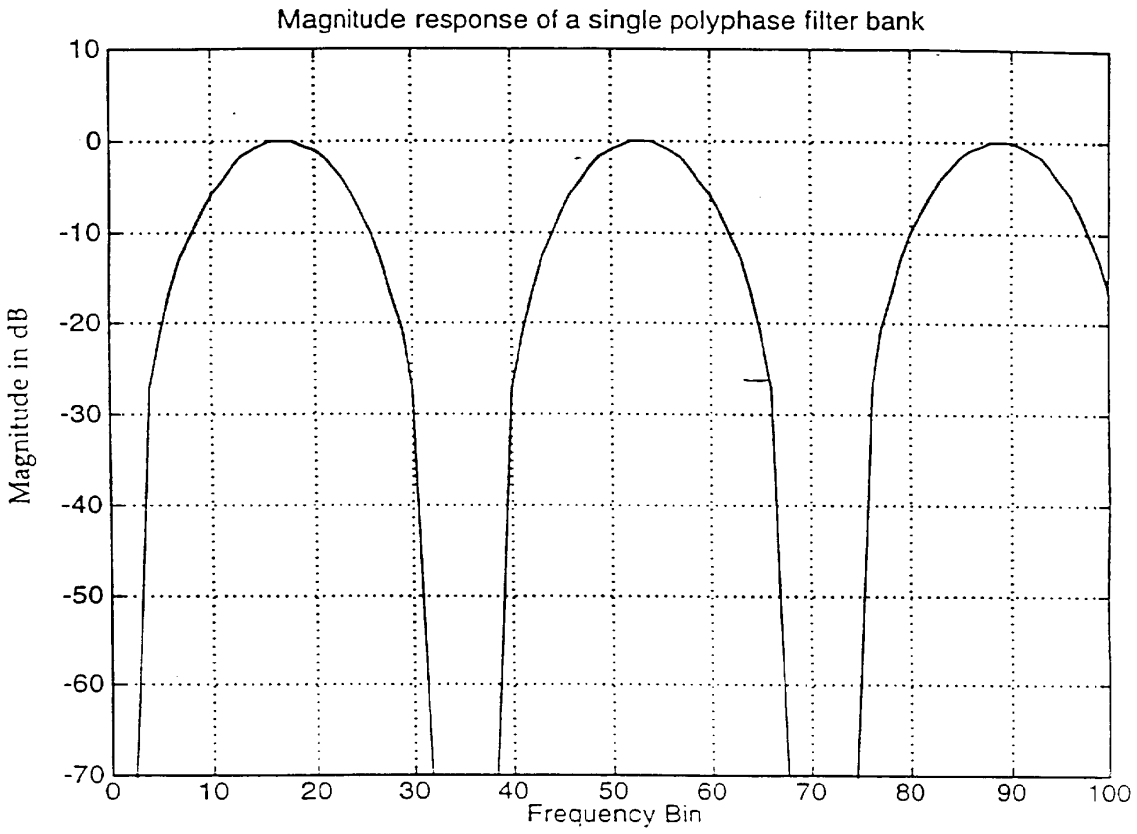

Figure 19

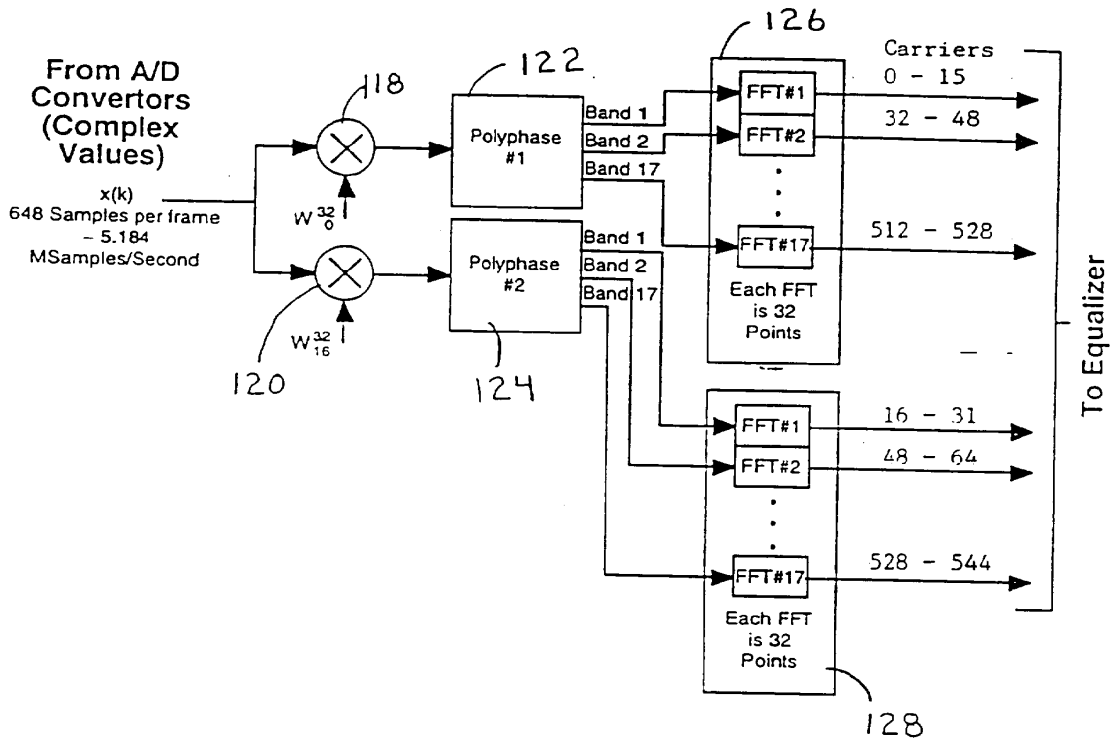

Figure 20

112

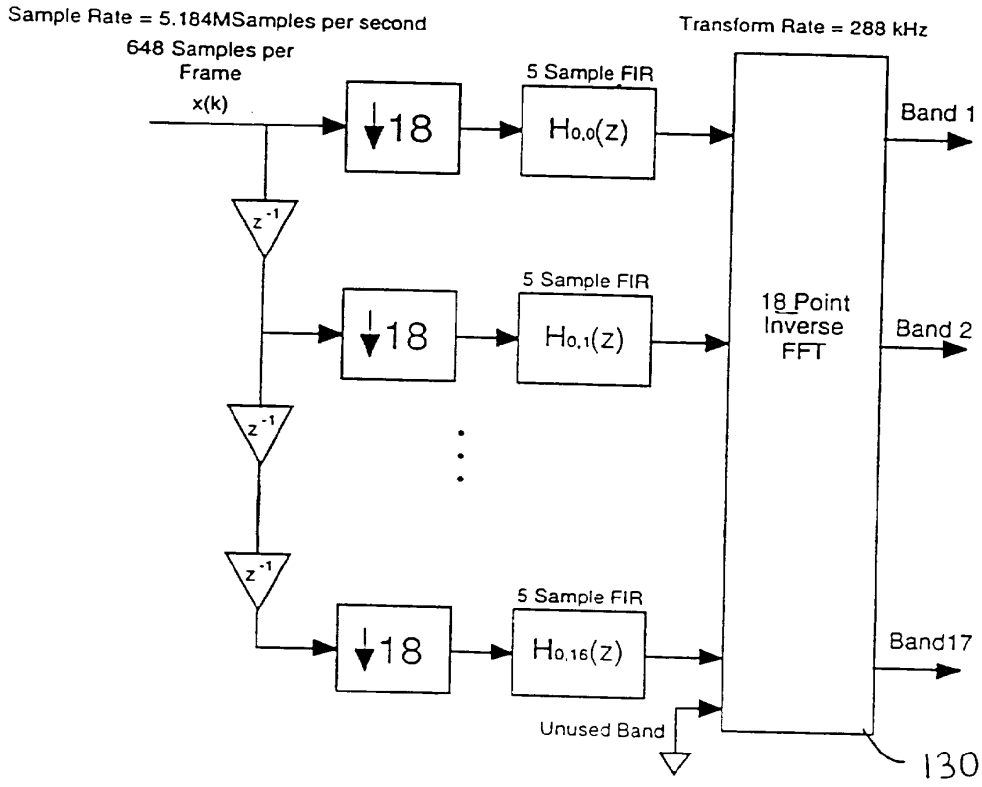
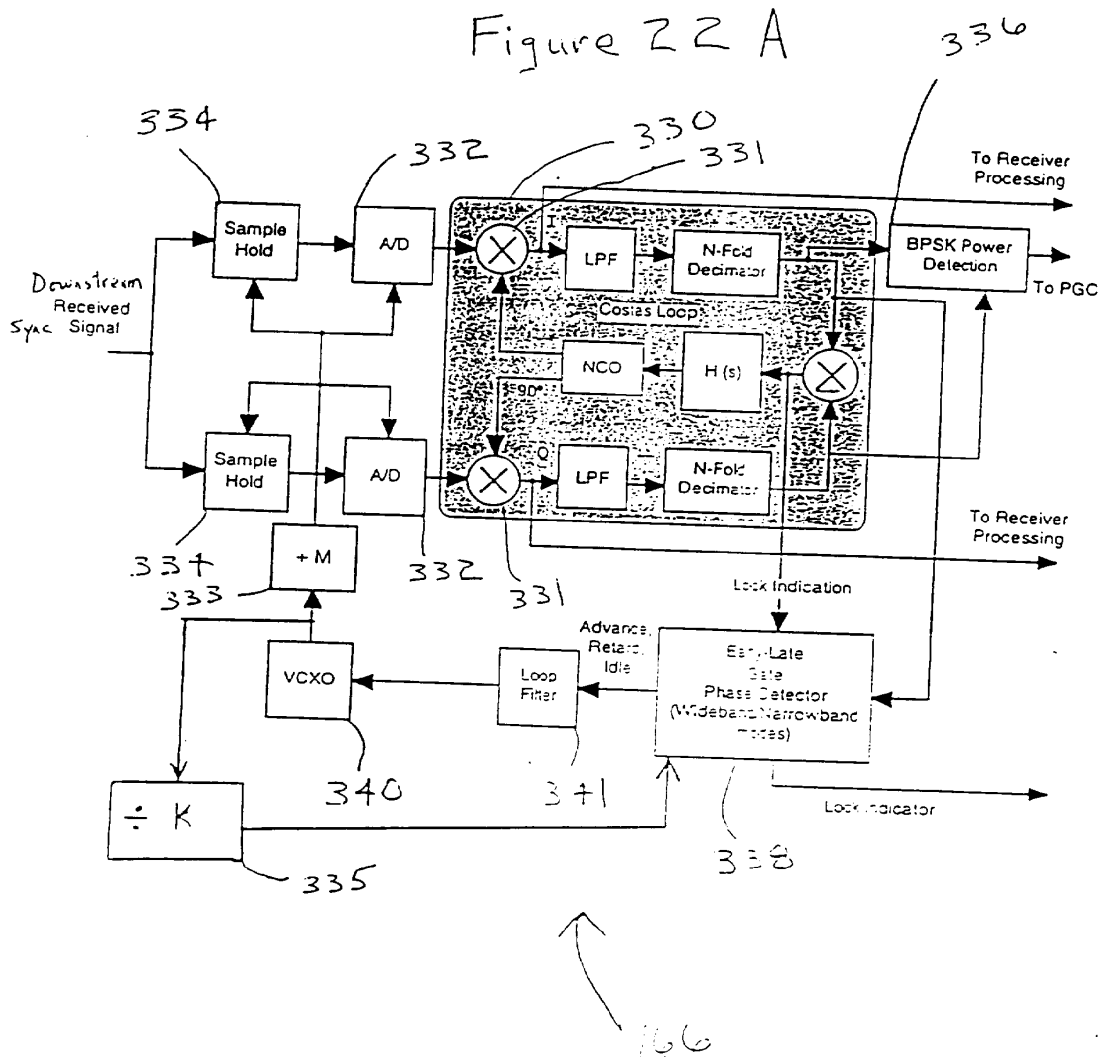

Figure 21

122, 124

Figure 22 A



26/35

Figure 22B

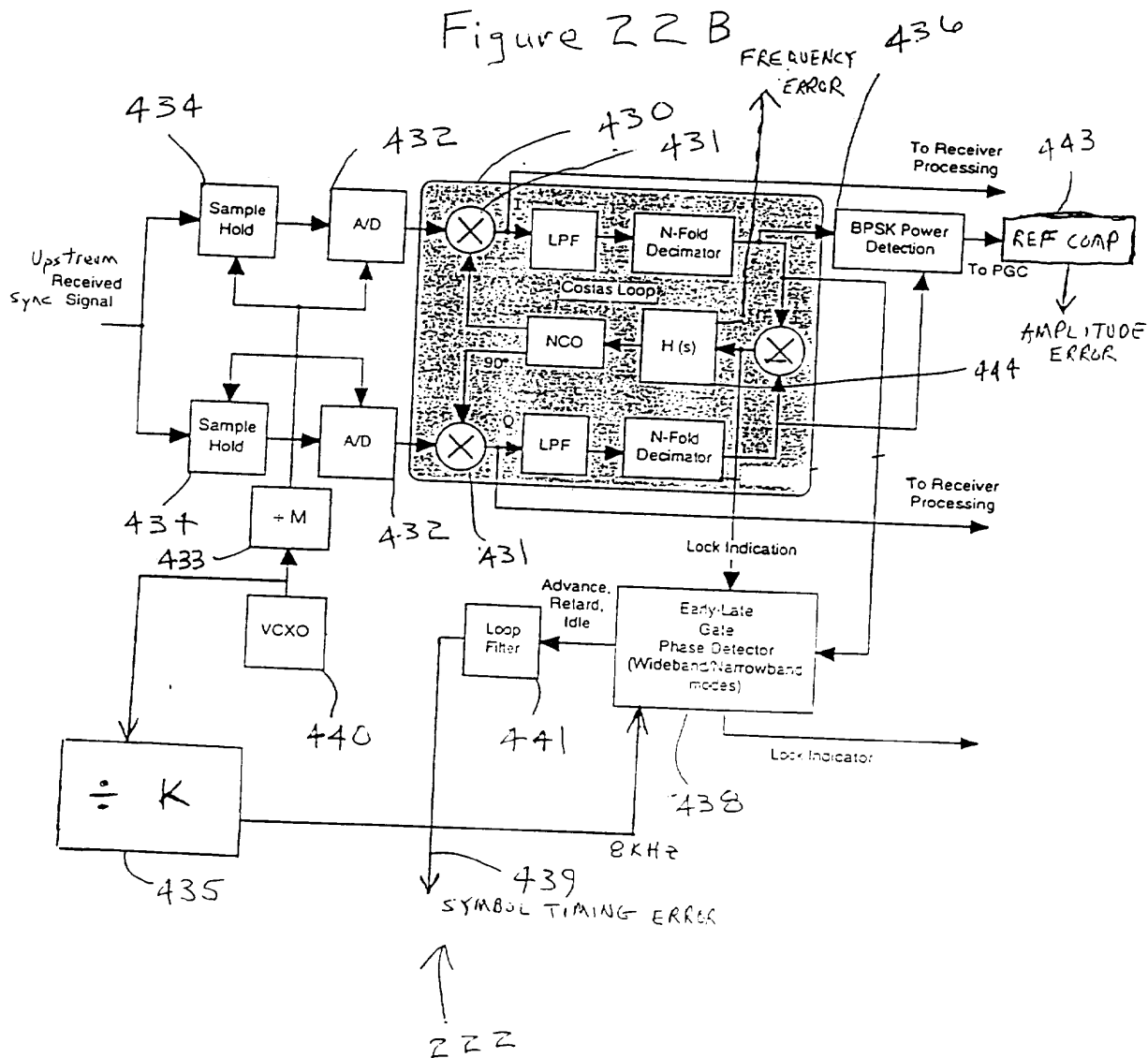
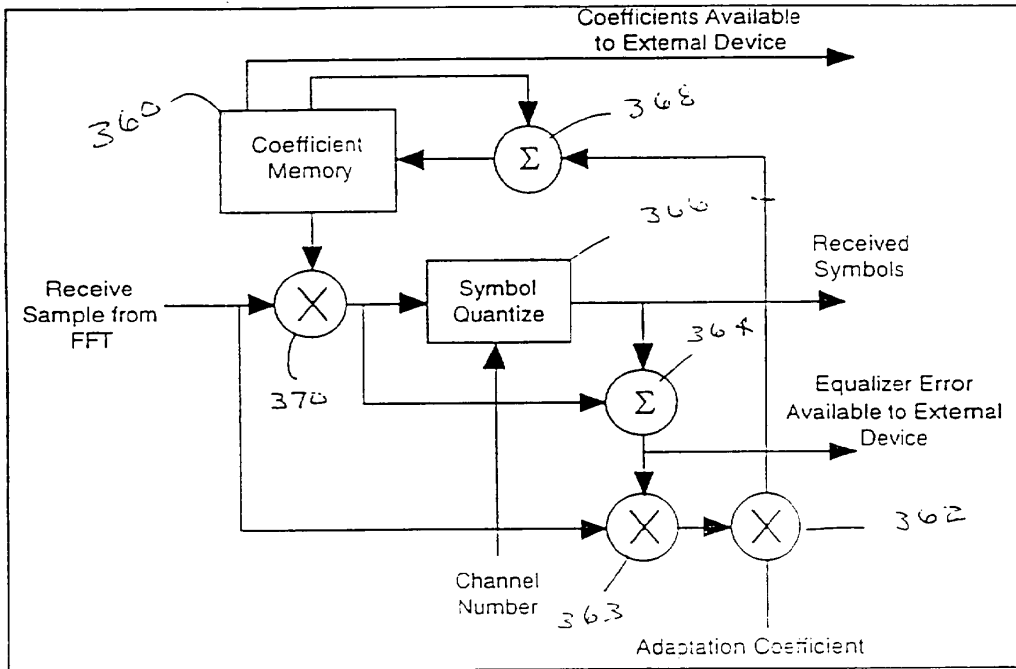



Figure 23



172, 217

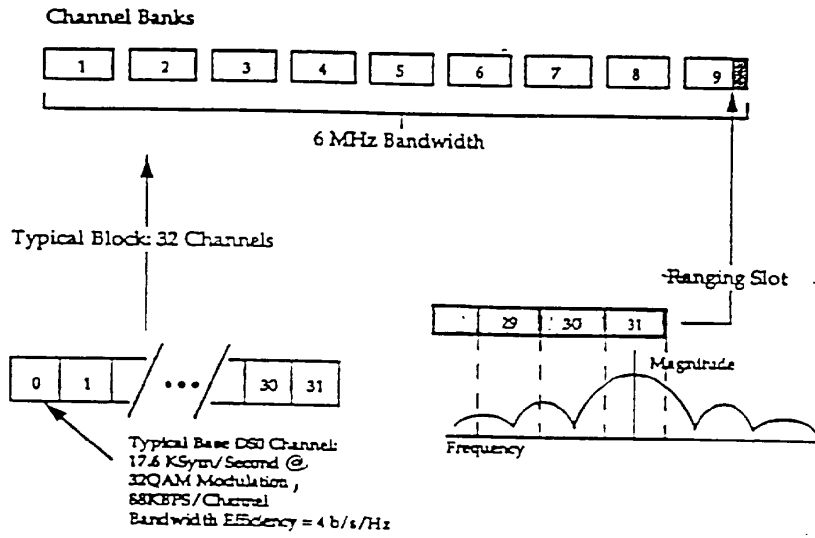

Figure 24

Figure 25

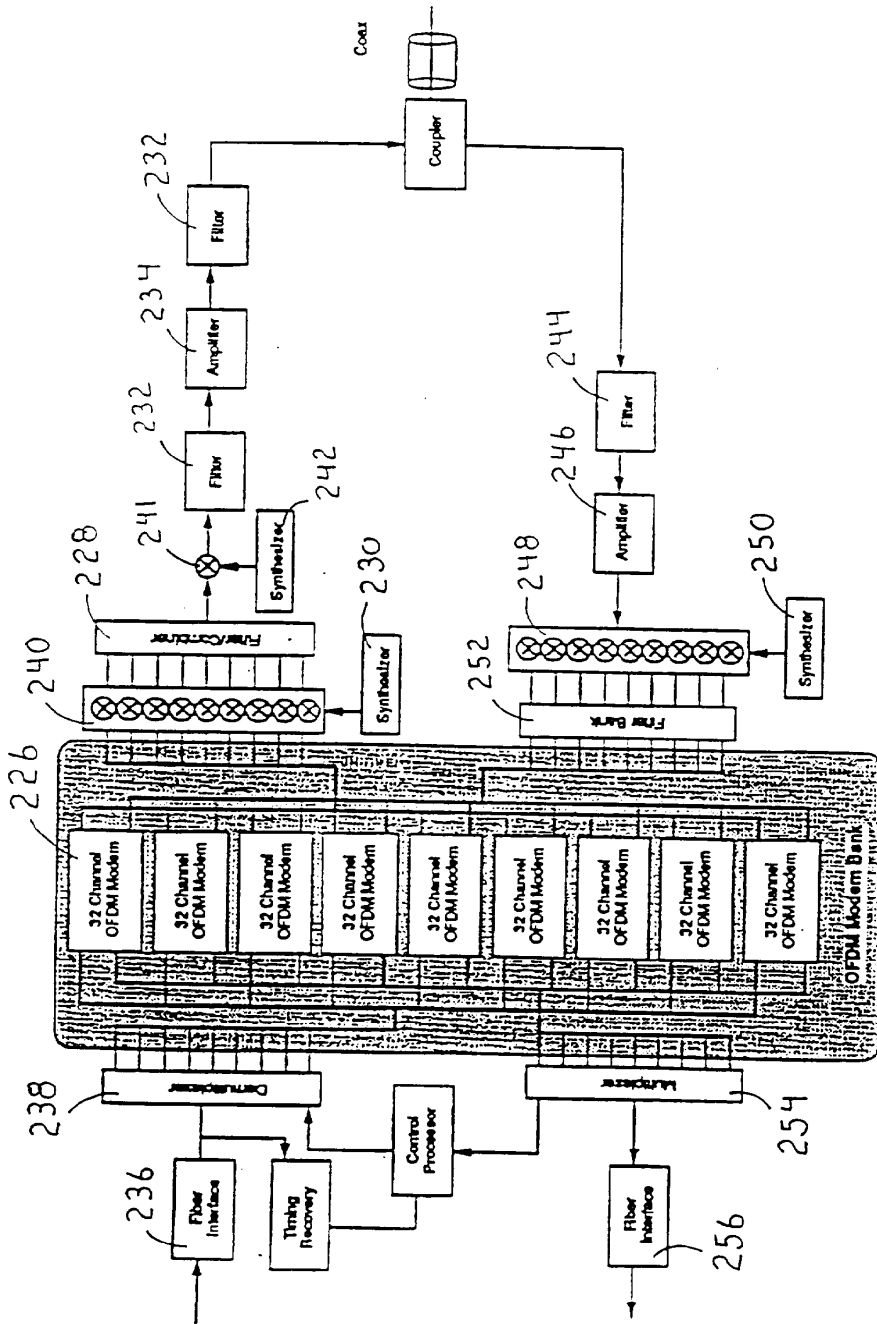
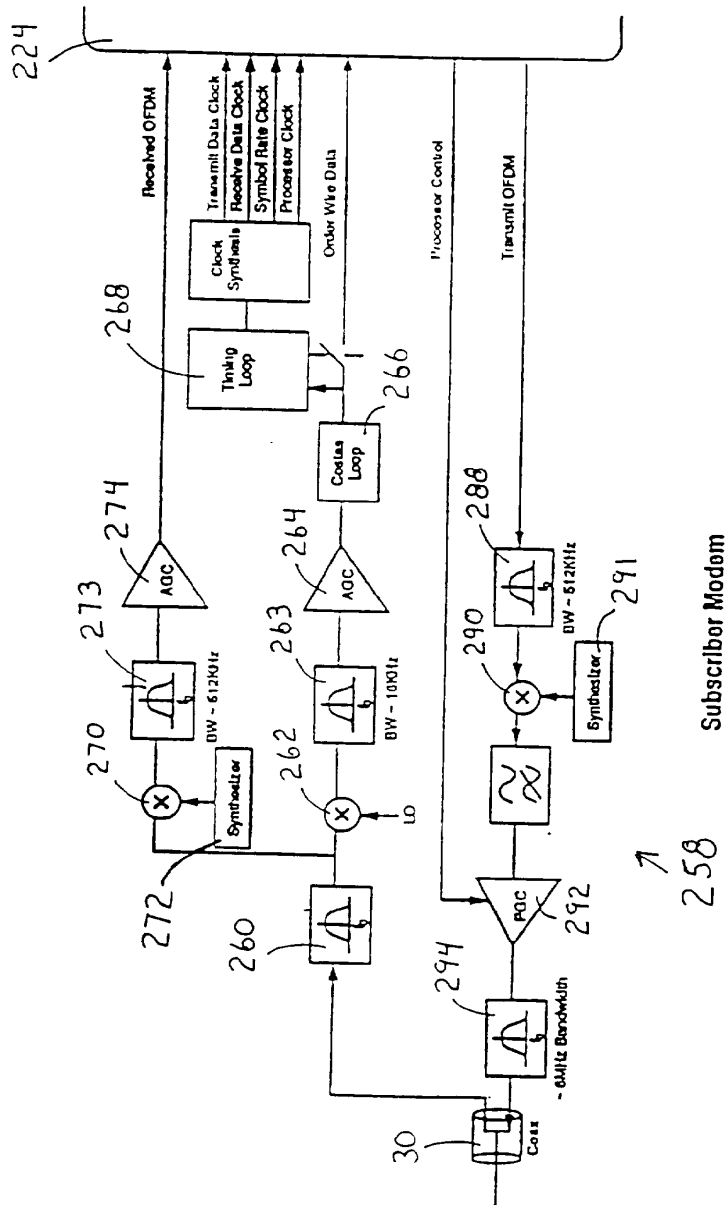

Figure 26



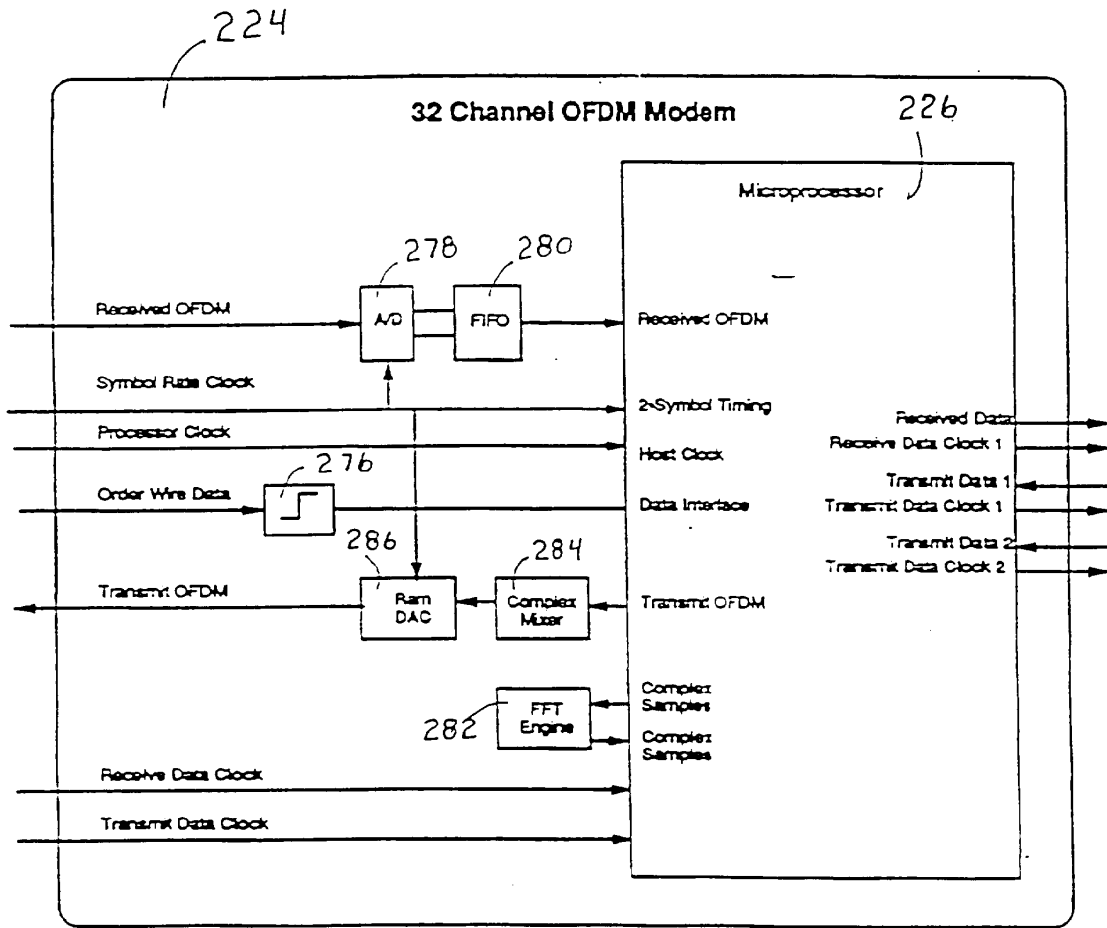

Figure 27

32 / 35

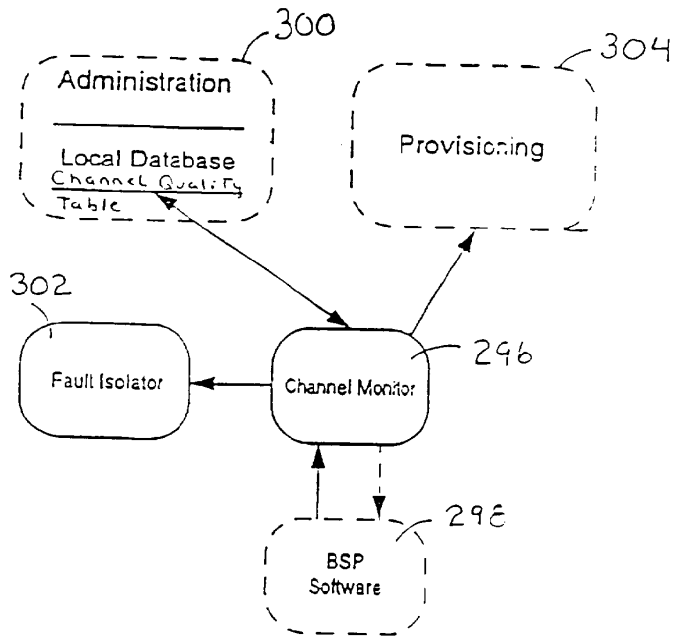

Figure 28

Figure 29A

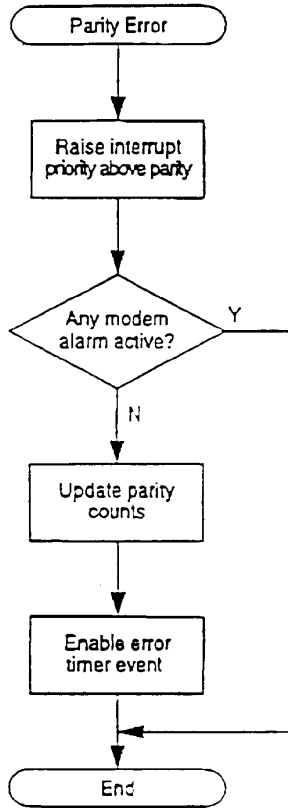

Figure 29B

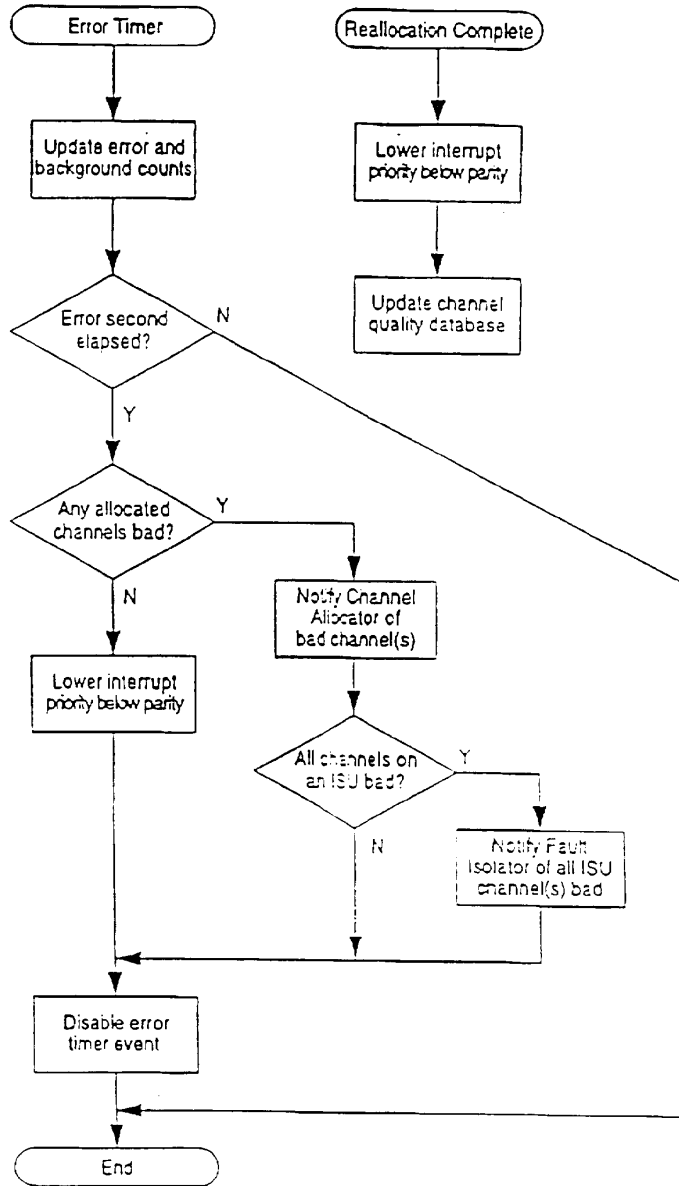

Figure 29C

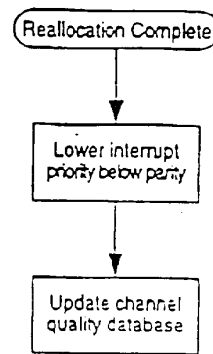
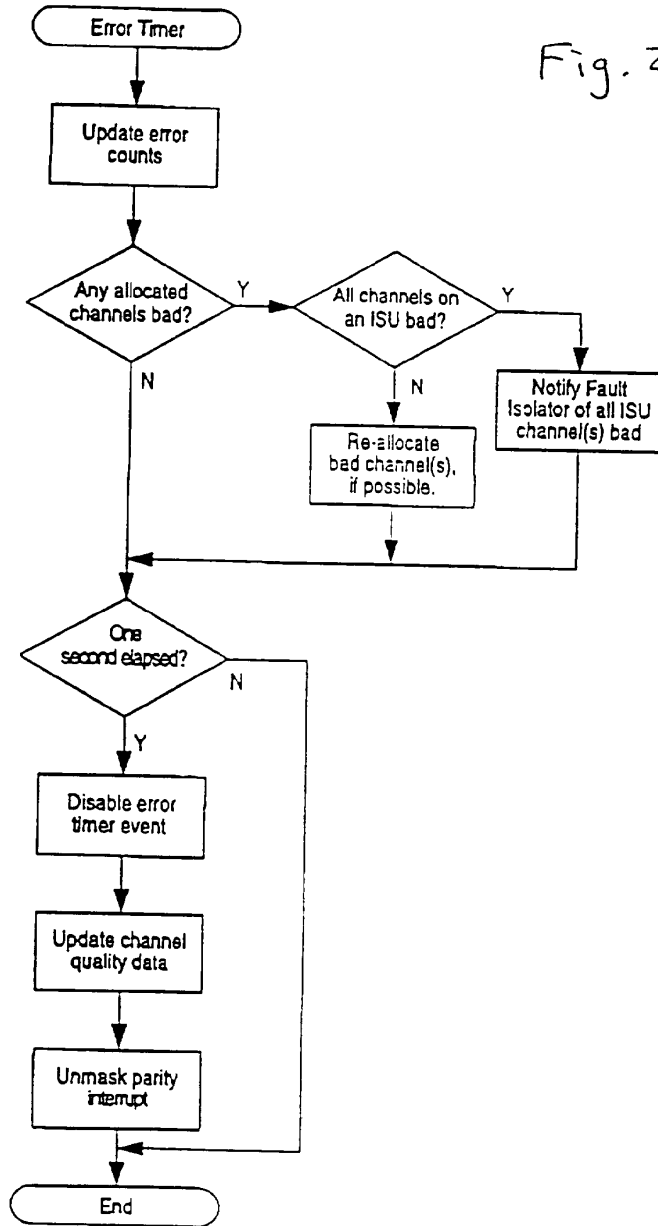

Fig. 29D





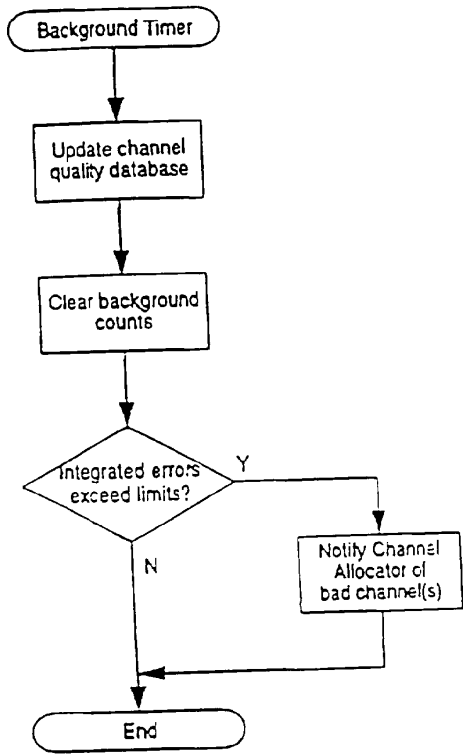

Figure 30

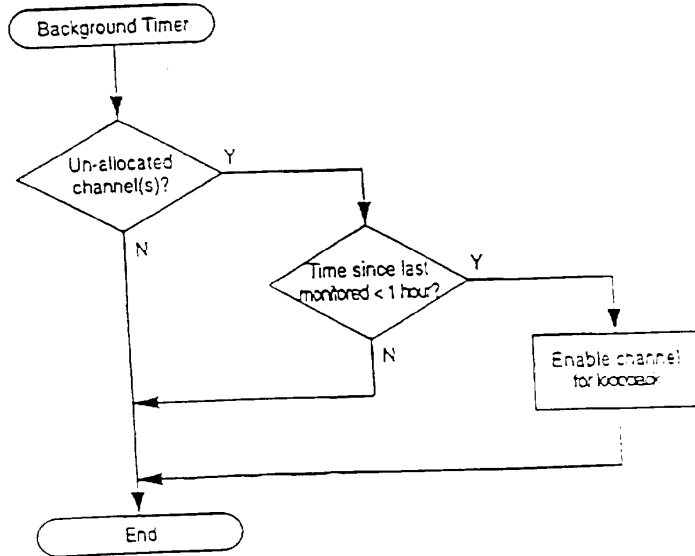

Figure 31



INTERNATIONAL APPLICATION PUBLISHED UNDER THE PATENT COOPERATION TREATY (PCT)

<p>(51) International Patent Classification <sup>6</sup> : <b>H04Q 7/38, H04L 5/06</b></p>	<p><b>A1</b></p>	<p>(11) International Publication Number: <b>WO 97/01256</b> (43) International Publication Date: 9 January 1997 (09.01.97)</p>
<p>(21) International Application Number: PCT/SE96/00814 (22) International Filing Date: 20 June 1996 (20.06.96) (30) Priority Data: 08/493,489 22 June 1995 (22.06.95) US (71) Applicant: TELEFONAKTIEBOLAGET LM ERICSSON (publ) [SE/SE]; S-126 25 Stockholm (SE). (72) Inventors: FRODIGH, Carl, Magnus; Langelandsgatan 43, 1 tr, S-164 43 Kista (SE). GUDMUNDSON, Perols, Leif, Mikael; Koldinggatan 4, 2 tr, S-164 46 Kista (SE). (74) Agents: BOHLIN, Björn et al.; Telefonaktiebolaget LM Ericsson (publ), Patent and Trademark Dept., S-126 25 Stockholm (SE).</p>	<p>(81) Designated States: AL, AM, AT, AU, AZ, BB, BG, BR, BY, CA, CH, CN, CZ, DE, DK, EE, ES, FI, GB, GE, HU, IL, IS, JP, KE, KG, KP, KR, KZ, LK, LR, LS, LT, LU, LV, MD, MG, MK, MN, MW, MX, NO, NZ, PL, PT, RO, RU, SD, SE, SG, SI, SK, TJ, TM, TR, TT, UA, UG, UZ, VN, ARIPO patent (KE, LS, MW, SD, SZ, UG), Eurasian patent (AM, AZ, BY, KG, KZ, MD, RU, TJ, TM), European patent (AT, BE, CH, DE, DK, ES, FI, FR, GB, GR, IE, IT, LU, MC, NL, PT, SE), OAPI patent (BF, BJ, CF, CG, CI, CM, GA, GN, ML, MR, NE, SN, TD, TG).</p> <p><b>Published</b> <i>With international search report. Before the expiration of the time limit for amending the claims and to be republished in the event of the receipt of amendments.</i></p>	

(54) Title: ADAPTIVE CHANNEL ALLOCATION IN A FREQUENCY DIVISION MULTIPLEXED SYSTEM

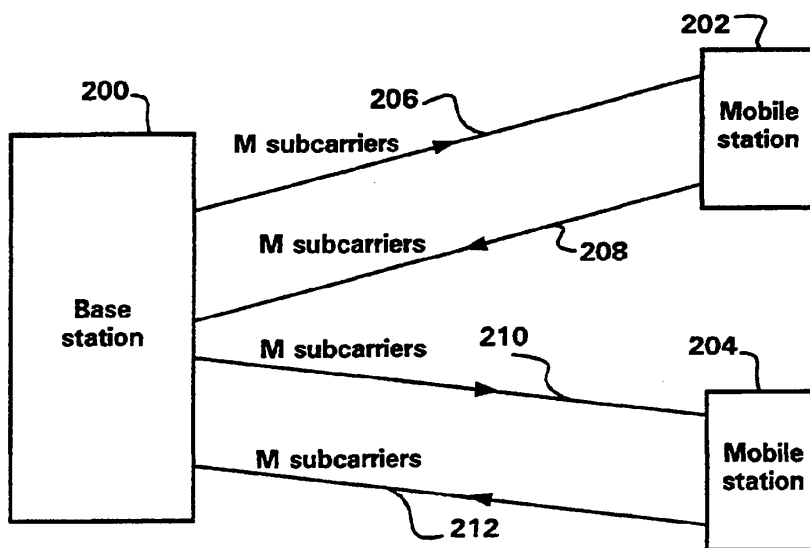

(57) Abstract

A method and system of adaptive channel allocation in a frequency division multiplexed system is provided. In the method and system, a subset of M subcarriers is chosen from a larger set of N subcarriers available for communications on a link. As communications take place on the link, signal quality (C/I) measurements (342) on the subcarriers of the subset of M subcarriers and interference (I) measurements (344) on the subcarriers of the group of N subcarriers are periodically performed. The C/I and I measurements are then used to reconfigure (422) the subset of M subcarriers to reduce co-channel interference on the link.

**FOR THE PURPOSES OF INFORMATION ONLY**

Codes used to identify States party to the PCT on the front pages of pamphlets publishing international applications under the PCT.

AM	Armenia	GB	United Kingdom	MW	Malawi
AT	Austria	GE	Georgia	MX	Mexico
AU	Australia	GN	Guinea	NE	Niger
BB	Barbados	GR	Greece	NL	Netherlands
BE	Belgium	HU	Hungary	NO	Norway
BF	Burkina Faso	IE	Ireland	NZ	New Zealand
BG	Bulgaria	IT	Italy	PL	Poland
BJ	Benin	JP	Japan	PT	Portugal
BR	Brazil	KE	Kenya	RO	Romania
BY	Belarus	KG	Kyrgystan	RU	Russian Federation
CA	Canada	KP	Democratic People's Republic of Korea	SD	Sudan
CF	Central African Republic	KR	Republic of Korea	SE	Sweden
CG	Congo	KZ	Kazakhstan	SG	Singapore
CH	Switzerland	LI	Liechtenstein	SI	Slovenia
CI	Côte d'Ivoire	LK	Sri Lanka	SK	Slovakia
CM	Cameroon	LR	Liberia	SN	Senegal
CN	China	LT	Lithuania	SZ	Swaziland
CS	Czechoslovakia	LU	Luxembourg	TD	Chad
CZ	Czech Republic	LV	Latvia	TG	Togo
DE	Germany	MC	Monaco	TJ	Tajikistan
DK	Denmark	MD	Republic of Moldova	TT	Trinidad and Tobago
EE	Estonia	MG	Madagascar	UA	Ukraine
ES	Spain	ML	Mali	UG	Uganda
FI	Finland	MN	Mongolia	US	United States of America
FR	France	MR	Mauritania	UZ	Uzbekistan
GA	Gabon			VN	Viet Nam

**ADAPTIVE CHANNEL ALLOCATION IN A  
FREQUENCY DIVISION MULTIPLEXED SYSTEM**

5     **BACKGROUND OF THE INVENTION**

Field of the Invention

This invention relates to cellular telecommunications systems and, more particularly, to a method and system of adaptive channel allocation in a frequency division  
10 multiplexed cellular system.

Description of the Prior Art

In a cellular telecommunications system the user of a mobile station communicates with the system through a  
15 radio interface while moving about the geographic coverage area of the system. The radio interface between the mobile station and system is implemented by providing base stations dispersed throughout the coverage area of the system, each capable of radio communication with the  
20 mobile stations operating within the system. In a typical cellular telecommunications system each base station of the system controls communications within a certain geographic coverage area termed a cell, and a mobile station which is located within a particular cell  
25 communicates with the base station controlling that cell. As a mobile station moves throughout the system control of the communication between the system and mobile station are transferred from cell to cell according to the movement of the mobile station throughout the system.

30 Existing cellular telecommunications systems operate according to various air interface standards which assure the compatibility of equipment designed to operate in a particular system. Each standard provides specific details of the processes that take place between the  
35 mobile stations and base stations of the system in all modes of operation, including during idle states, during rescan of control channels, during registration, and

-2-

during connection to voice or traffic channels. Advances in cellular systems technology have been rapid in recent years. These advances in technology have been driven by increases in demand for the increasingly sophisticated services offered by cellular systems. As cellular systems technology and the total number of cellular systems has increased worldwide to meet this demand, there has also been an accompanying increase in the number of system standards according to which these cellular systems operate.

In cellular telecommunications systems, as in most radio systems, the frequency bandwidth available for use is a limited resource. Because of this, emphasis is often concentrated on making the most efficient use possible of the available frequency bandwidth when developing new cellular systems. Additionally, communications within cellular systems are often subject to certain types of RF signal distortion such as multipath propagation and co-channel interference. The development of new system standards has also emphasized the need to minimize the effect of these RF signal distortions on communications within the cells of a system.

Frequency division multiplexing (FDM) is a method of transmitting data that has application to cellular systems. Orthogonal frequency division multiplexing (OFDM) is a particular method of FDM that is particularly suited for cellular systems. An OFDM signal consists of a number of subcarriers multiplexed together, each subcarrier at a different frequency and each modulated by a signal which varies discretely rather than continuously. Because the level of the modulating signal varies discretely, the power spectrum of each subcarrier follows a  $(\sin x/x)^2$  distribution. The spectral shape transmitted on each subcarrier is such that the spectra of the individual sub-channels are zero at the other subcarrier frequencies and interference does not occur between subcarriers. Generally, N serial data elements modulate

-3-

N subcarrier frequencies, which are then frequency division multiplexed. Each of the N serial data elements comprises a data block with a duration of  $T=1/f_s$ , where  $f_s$  is the bandwidth of the OFDM signal. The subcarriers of the OFDM system are separated in frequency by multiples of  $1/T$ . Although the frequency spectrum of the subcarriers overlap, this frequency spacing makes the subcarriers orthogonal over one symbol interval so that the peak of power of each modulated carrier occurs at frequencies corresponding to nulls in the power spectrum of the other carriers. The overall spectrum of an OFDM signal is close to rectangular when a large number of OFDM carriers are contained in the OFDM signal.

During the time period,  $T$ , the OFDM signal may be represented by a block of  $N$  samples. The value of the  $N$  samples is as follows:

$$x(n) = \sum_{k=0}^{N-1} X(k) e^{2jnk/N}$$

The  $N$  values  $X(k)$  represent the respective data during period  $T$ , of the discretely-varying signals modulating the OFDM carriers  $e^{2jnk/N}$ . From the above, the OFDM signal corresponds to the inverse Discrete Fourier Transform of the set of data samples  $X(k)$ . To convert a data stream into an OFDM signal, the data stream is split up into blocks of  $N$  samples  $X(k)$  and an inverse Discrete Fourier Transform is performed on each block. The string of blocks that appears at a particular sample position over time constitutes a discretely-varying signal that modulates a certain subcarrier at a frequency  $f_n$ .

OFDM offers several advantages that are desirable in a cellular system. In OFDM the orthogonality of the subcarriers in the frequency spectrum allows the overall spectrum of an OFDM signal to be close to rectangular. This results in efficient use of the bandwidth available

-4-

to a system. OFDM also offers advantages in that interference caused by multipath propagation effects is reduced. Multipath propagation effects are caused by radio wave scattering from buildings and other structures in the path of the radio wave. Multipath propagation may result in frequency selective multipath fading. In an OFDM system the spectrum of each individual data element normally occupies only a small part of the available bandwidth. This has the effect of spreading out a multipath fade over many symbols. This effectively randomizes burst errors caused by the frequency selective multipath fading, so that instead of one or several symbols being completely destroyed, many symbols are only slightly distorted. Additionally, OFDM offers the advantage that the time period  $T$  may be chosen to be relatively large as compared with symbol delay time on the transmission channel. This has the effect of reducing intersymbol interference caused by receiving portions of different symbols at the same time.

The use of OFDM in cellular systems has been proposed by Cimini, "Analysis and Simulation of a Digital Mobile Channel Using Orthogonal Frequency Division Multiplexing", IEEE Trans. Commun., Vol. 33, No. 7, pp. 665-675 (July, 1985). A similar application of OFDM in a mobile system has also been proposed by Casa, "OFDM for Data Communication Over Mobile Radio FM-Channels-Part I: Analysis and Experimental Results", IEEE Trans. Commun., Vol. 39, No. 5, pp. 783-793 (May, 1991). In these OFDM cellular systems a set of subcarrier frequencies is assigned to each communications link created for transmission from a base station to a mobile station (downlink) and from a mobile station to a base station (uplink) operating within a cell. The set of subcarrier frequencies allocated to each communications link is chosen from all subcarrier frequencies available to the system. Within a cell the same subcarrier frequency cannot be assigned to more than one communications link.

-5-

Thus, co-channel interference between subcarriers within the same cell does not occur. However, it is possible in such an OFDM system that a communications link in a cell of the system is assigned a set of subcarriers frequencies that includes one or more subcarriers frequencies also assigned to a communications link set up in another cell within the system. Each of these commonly assigned subcarriers frequencies may be subject to co-channel interference caused by the use of the same subcarrier frequency in the other cells. In these OFDM systems no method or system exists for coordinating the assignment of subcarrier frequencies to communications links created within different cells. In such a system the co-channel interference in a communications link caused by a subcarrier used in a neighboring cell could be very large.

Methods of allocating channel frequencies among cells in non-OFDM systems have been developed that reduce or minimize co-channel interference. Adaptive Channel Allocation (ACA) is such a method. In ACA any channel frequency allocated to a cellular system may be used to set up a link in any cell of the system regardless of whether or not the frequency is used elsewhere in the system as long as certain interference criteria are met. The channel frequencies may also be freely reused throughout the system as long as the interference criteria are met.

In Adaptive Channel Allocation various measurements of signal quality and interference levels on dynamically allocated channel frequencies are performed within the coverage area of a cell to build a list of traffic or voice channels that may be assigned to communications links to be created within the cell. The base station controlling the cell and mobile stations within the cell's coverage area perform measurements on the set of channel frequencies that the system operator has allocated to be dynamically allocated for communications within the system. Generally, both uplink and downlink measurements



-6-

are performed. Based on these measurements, when a new link is to be created, a channel frequency is assigned to the link based on some rule. For example, in minimum interference ACA the system builds a table of channels from the least interfered (highest quality) to the most interfered (lowest quality) channels as measured within each cell. The system then selects a certain number of least interfered channel frequencies from that list to allocate to communication in that cell. Other criteria, such as certain required frequency separation between the channels chosen and avoiding certain combinations of channels whose frequencies create intermodulation are also considered. As an example of ACA, H. Eriksson, "Capacity Improvement by Adaptive Channel Allocation", IEEE Global Telecomm. Conf., pp. 1355-1359, Nov. 28-Dec. 1, 1988, illustrates the capacity gains associated with a cellular radio system where all of the channels are a common resource shared by all base stations. In the above-referenced report, the mobile measures the signal quality of the downlink, and channels are assigned on the basis of selecting the channel with the highest carrier to interference ratio (C/I level).

Existing ACA algorithms which have been created for non-OFDM cellular systems using one carrier frequency for each link cannot be effectively used in a cellular system using OFDM. One problem with the existing ACA techniques is that the number of subcarriers in an OFDM system is large compared to the number of carriers in the system that uses a single carrier for each communications link. This requires an extensive measurement effort that expends both time and system resources to obtain the uplink and downlink measurement results necessary for ACA. In addition, in order to transfer the results of the large number of downlink measurements made at a mobile station to the system for processing, use of a large amount of signaling resources is necessary.

-7-

It would provide an advantage then, to have a method and system of adaptive channel allocation for use in an OFDM system. The method and system should provide an allocation of subcarriers within an OFDM system that lessens co-channel interference between cells of the system. The method and system should also be designed to take into account the unique features of the OFDM system in order to utilize system resources effectively when allocating channels. The present invention provides such a method and system.

#### SUMMARY OF THE INVENTION

The present invention provides a method and system of adaptive channel allocation (ACA) in an orthogonal frequency division multiplexed (OFDM) system. The method and system provides an allocation of subcarriers to each link of the OFDM system that lessens co-channel interference between cells of the system.

The present invention also overcomes the difficulties and shortcomings presented with implementing conventional ACA methods and systems designed for use in a non-OFDM system into an OFDM system. Conventional ACA methods are designed to adaptively allocate RF channels to systems where one channel is used per link. As applied to an OFDM system, these conventional ACA methods would require that all OFDM subcarriers assigned to users to be adaptively allocated. Adaptively allocating all OFDM subcarriers in an OFDM system would require an overly large amount of measurement and signaling resources to transfer channel measurement information and the assignment information between receivers and transmitters of the system. By selectively choosing the subcarriers to be adaptively allocated, and setting criteria for allocation determination, the system and method of the present invention minimizes the use of measurement and signaling resources while still providing effective ACA.

-8-

In a first aspect of the invention, an initial subset of M subcarriers is chosen from a larger group of N subcarriers that are available for communications on each separate link of the OFDM system. The number M depends  
5 on the data rate of the particular link and may vary between the links of the system. The subset of M subcarriers is then used to carry communications on the link. As communications take place, the signal quality level (C/I) of the subcarriers within the subset of M  
10 subcarriers, and the interference level (I) of all N available subcarriers is periodically measured. These C/I and I measurement results are reported to the system. During communications on the link the system determines from the C/I and I measurements if a more preferred unused  
15 subcarrier which would give better signal reception on the link than a subcarrier of the set of M is available in the cell within which the link exists. If it is determined that a more preferred unused subcarrier exists, the system reconfigures the subset of M subcarriers to include the  
20 unused subcarrier.

In a second aspect of the invention, a mobile station as link receiver transmits only a limited set of measurement results to the system at certain select reporting intervals rather than all measurement results.  
25 The transmitted limited set of measurement results comprises a select number of the lowest C/I measurement results and a select number of the lowest I measurement results. The transmission of the limited set of results reduces the use of uplink system signaling resources.

In an alternative embodiment of the invention a mobile station as link receiver periodically measures the signal quality level (C/I) of the subcarriers within the subset of M subcarriers, and the interference level (I) of all N available subcarriers. The mobile station then  
30 determines candidate replacement subcarriers for the link based on the C/I and I measurements, and transmits a subcarrier request message to the system requesting that  
35

-9-

the candidate subcarrier be assigned to replace a subcarrier of the link. The system responds to the subcarrier request message with a subcarrier accepted or subcarrier rejected message. If a subcarrier accepted message is received, the mobile station reconfigures the subset of M subcarriers to contain the candidate replacement subcarrier. If the subcarrier is rejected, the mobile station transmits a subcarrier request message requesting a new candidate subcarrier.

10

**BRIEF DESCRIPTION OF THE DRAWINGS**

FIG. 1 illustrates a cellular telecommunications network within which the present invention may be implemented;

15

FIG. 2A illustrates the allocation of subcarriers in accordance with the present invention in an orthogonal frequency division multiplexed system;

FIG. 3A is a block diagram of a system according to an embodiment of the present invention;

20

FIGS. 3B and 3C are block diagrams of a link transmitter and link receiver, respectively, according to an embodiment of the present invention;

FIGS. 4A and 4B are flow diagrams of process steps according to an embodiment of the present invention performed by a link receiver;

25

FIG. 5 is a flow diagram of process steps according to an embodiment of the present invention performed within a cellular telecommunications network;

FIGS. 6A and 6B are flow diagrams of process steps according to an alternative embodiment of the present invention performed by a link receiver; and

30

FIG. 7 is a flow diagram of process steps according to an alternative embodiment of the present invention performed within a cellular telecommunications system.

35

**DETAILED DESCRIPTION OF THE INVENTION**

-10-

Referring to FIG. 1, there is illustrated a frequency division multiplexed (FDM) cellular telecommunications system of the type to which the present invention generally pertains. In FIG. 1, an arbitrary geographic area may be divided into a plurality of contiguous radio coverage areas, or cells C1-C10. While the system of FIG. 1 is illustratively shown to include only 10 cells, it should be clearly understood that in practice, the number of cells will be much larger.

Associated with and located within each of the cells C1-C10 is a base station designated as a corresponding one of a plurality of base stations B1-B10. Each of the base stations B1-B10 includes a transmitter, a receiver, and a base station controller as are well known in the art. In FIG. 1, the base stations B1-B10 are illustratively located at the center of each of the cells C1-C10, respectively, and are equipped with omni-directional antennas. However, in other configurations of the cellular radio system, the base stations B1-B10 may be located near the periphery, or otherwise away from the center of the cells C1-C10 and may illuminate the cells C1-C10 with radio signals either omni-directionally or directionally. Therefore, the representation of the cellular radio system of FIG. 1 is for purposes of illustration only and is not intended as a limitation on the possible implementations of the cellular telecommunications system within which the present invention is implemented.

With continuing reference to FIG. 1, a plurality of mobile stations M1-M10 may be found within the cells C1-C10. Again, only 10 mobile stations are shown in FIG. 1 but it should be understood that the actual number of mobile stations will be much larger in practice and will invariably greatly exceed the number of base stations. Moreover, while none of the mobile stations M1-M10 may be found in some of the cells C1-C10, the presence or absence of the mobile stations M1-M10 in any particular one of the

-11-

cells C1-C10 should be understood to depend in practice on the individual desires of the users of mobile stations M1-M10 who may roam from one location in the cell to another or from one cell to an adjacent cell or neighboring cell, and even from one cellular radio system served by a particular MSC to another such system.

Each of the mobile stations M1-M10 is capable of initiating or receiving a telephone call through one or more of the base stations B1-B10 and a mobile station switching center MSC. A mobile station switching center MSC is connected by communication links, e.g., cables, to each of the illustrative base stations B1-B10 and to the fixed public switched telephone network PSTN, not shown, or a similar fixed network which may include an integrated system digital network (ISDN) facility. The relevant connections between the mobile station switching center MSC and the base stations B1-B10, or between the mobile station switching center MSC and the PSTN or ISDN, are not completely shown in FIG. 1 but are well known to those of ordinary skill in the art. Similarly, it is also known to include more than one mobile station switching center in a cellular radio system and to connect each additional mobile station switching center to a different group of base stations and to other mobile station switching center via cable or radio links.

Each MSC may control in a system the administration of communication between each of the base stations B1-B10 and the mobile stations M1-M10 in communication with it. As a mobile station roams about the system, the mobile station registers its location with the system through the base station that controls the area in which the mobile station is located. When the mobile station telecommunications system receives a call addressed to a particular mobile station, a paging message addressed to that mobile station is broadcast on control channels of the base stations which control the area in which the mobile station is believed to be located. Upon receiving

-12-

the paging message addressed to it, the mobile station scans system access channels and sends a page response to the base station from which it received the strongest access channel signal. The process is then initiated to create the call connection. The MSC controls the paging of a mobile station believed to be in the geographic area served by its base stations B1-B10 in response to the receipt of a call for that mobile station, the assignment of radio channels to a mobile station by a base station upon receipt of a page response from the mobile station, as well as the handoff communications with a mobile station from one base station to another in response to the mobile station traveling through the system, from cell to cell, while communication is in progress.

Each of the cells C1-C10 is allocated a plurality of FDM subcarrier frequencies and at least one dedicated control channel. The control channel is used to control or supervise the operation of mobile stations by means of information transmitted to and received from those units. Such information may include incoming call signals, outgoing call signals, page signals, page response signals, location registration signals and voice and traffic subcarrier assignments.

The present invention involves implementation of a method and system of adaptive channel allocation (ACA) into an FDM cellular system as shown in FIG. 1. In an exemplary embodiment of the invention, ACA is implemented into an OFDM system operating with a total system bandwidth of 5MHz and a subcarrier spacing of 5KHz. The total number of subcarriers available for this system is approximately  $5\text{MHz}/5\text{KHz} = 1000$ . The subcarriers are modulated onto a system RF carrier with a frequency of 2GHz for transmission over the system RF channel and the frequency spectra of the transmitted signal is centered around the RF carrier. All subcarriers are available for use in each cell but a subcarrier may not be used simultaneously on more than one link in a cell. Frequency

-13-

division duplex (FDD) is used for separation of the uplink and downlink subcarriers frequencies. The system includes a dedicated control channel (DCCH) that is both an uplink and downlink channel for transmitting control information for handovers, long term channel allocation information, long term power control information and measurement messages and measurement results. The system also includes a physical control channel (PCCH) that is both an uplink and downlink channel for transmitting short term channel allocation information, short term power control information, measurement messages and measurement results.

In the ACA of the invention, for each up/down link between a mobile station and base station, the system chooses a subset of a number (M) of subcarriers from a set of a number (N) of subcarriers. The set of N subcarriers is the set of subcarriers available within the system for each link, where  $N > M$ . The set of N subcarriers does not change during a communication. The set of N subcarriers may include all subcarriers of the system. Alternatively, the set of N subcarriers may be a set less in number than the total number of subcarriers available but greater in number than the number of carriers in the subset of M subcarriers.

Referring now to FIG. 2 therein is illustrated the allocation of subcarriers in accordance with the present invention in an OFDM system. Base station 200 communicates with mobile station 202 over downlink 206 and uplink 208. Base station 200 also communicates with mobile station 204 over downlink 210 and uplink 212. Transmissions on links 206, 208, 210 and 212 are made over the system RF channel. Voice and data to be transmitted on each link are modulated onto a number (M) subcarriers. The M subcarriers are then modulated onto the system RF carrier for transmission over the system RF channel. Each link 206, 208, 210 and 212, within the cell uses a separate subset of M subcarriers. The subcarriers can only be used once within a cell.



-14-

Referring now to FIG. 3A, therein is shown a block diagram of a system according to the present invention. The system consists of a link transmitter 300, link receiver 330, ACA processing portion 360 and RF channel 380. The receiver 330 and transmitter 300 of a particular link are located at opposite ends of the link. In the downlink the receiver 330 is located in the mobile station and the transmitter 300 is located in the base station. In the uplink the receiver 330 is located in the base station and the transmitter 300 is located in the mobile station. RF channel has a set of N available subcarriers. The link receiver 330 and link transmitter communicate over RF channel 380 using a subset of M of the available subcarriers.

Referring now to FIGS. 3B and FIG. 3C, therein are shown functional block diagrams of transmitter 300 and receiver 330, respectively, of FIG. 3A. The functional features that are shown in FIG. 3B and FIG. 3C are common to both the base and mobile station receivers and transmitters.

Transmitter 300 includes a serial to parallel converter 302, mapping circuitry (MAP) 304, inverse fast fourier transform (IFFT) circuitry 306, a frequency multiplexer (MuX) 308, and modulator 310. In transmitter operation, serial to parallel converter 302 converts a serial digital data stream 312 into blocks of M symbols 314 where M is determined by the symbol size and data rate of the system. The M symbols are then input to the MAP circuitry 304, where each of the M symbols is mapped onto a subcarrier input of the IFFT circuitry 306. An inverse fast fourier transform (IFFT) is then performed on the blocks of data input to the IFFT circuitry 306. The signals 318 generated at the N outputs of the IFFT circuitry 306 are then multiplexed in MuX 308 to create a signal 320 containing M multiplexed subcarriers, each of which carries the data contained in one symbol of the M symbols 314. The signal 320 is then modulated onto the

-15-

system RF carrier 324 at modulator 310 and transmitted as an OFDM signal over the system RF channel 322.

Receiver 330 includes demodulator 332, frequency demultiplexer (DEMUX) 334, fast fourier transform (FFT) circuitry 336, de-mapping circuitry (DEMAP) 338, a parallel to serial converter 340, interference measuring means 344, signal quality measurement means 342 and processor 346. In receiver operation, the system RF carrier is received on the system RF channel 322 and then demodulated at demodulator 332, and demultiplexed at DEMUX 334 to obtain N samples 348 of the signal containing, the M multiplexed subcarriers. A fast fourier transform (FFT) is then performed by FFT circuitry 336 with the N samples 348 as inputs to generate data signals 350 containing any modulating data that was transmitted on each subcarrier. The N subcarriers demodulated and subjected to the FFT are determined by parameters input to DEMUX 334 and FFT circuitry 336 from processor 346. Interference measurement means 344 measures the interference (I) level on each of the data signals 350 recovered from each of the N samples 348. The N received data signals 350 are then input to the de-mapping block 338 where the M data signals 352 received on the M subcarrier frequencies currently assigned to link communications are de-mapped from the N data signals 350. The de-mapping is done according to parameters input to DEMAP block 338 from processor 346. The M de-mapped data signals 352 are then input to the parallel to serial converter 340 and converted into serial received data 354. Signal quality (C/I) is measured at the output of the de-mapping block 338 for each of the M de-mapped data signals 352 received on the M subcarrier frequencies currently assigned to the link on which receiver 330 is receiving.

The adaptive channel allocation for each link is implemented by ACA processing portion 360 of FIG. 3A which operates on results of measurements performed in the link receiver. In the embodiment shown, processor 346 receives

-16-

interference measurements from interference measurement means 344 and signal quality measurement results from signal quality measurement means 342. The processor 346 operates on the measurement results to generate data for  
5 input to ACA processing portion 360 of the system. The data generated by processor 346 will then be transferred to ACA processing portion 360 over interface 362. In the embodiment shown, ACA processing portion 360 is located within the MSC. ACA processing portion 360 may be  
10 alternatively located within the base stations of the system. It is also conceivable the functions performed by the ACA processing portion be distributed among the mobile station, base station and MSC. Methods of configuring memories to store the necessary data, and  
15 methods of configuring microprocessors and software to perform these types of functions are well known to those skilled in the art.

When a mobile station functions as link receiver, the processor 346 transfers the ACA data to the mobile station  
20 transmitter for transmission to the system over interface 362 which comprises the uplink on the appropriate control channel. In a base station as link receiver, the processor 346 transfers the ACA data to the MSC over interface 362 which comprises landline or other connections. ACA  
25 processing portion 360 operates on the data and then returns appropriate subcarrier assignment commands to link receiver 330 over interface 364 which comprises landline or other connections when the base station is the link receiver, or the down link on the appropriate control  
30 channel when the mobile station is the link receiver. Processor 346 of link receiver 330 receives the commands and then generates the correct input parameters for the receiver so that the correct subcarriers for the link are received. ACA processing portion 360 also sends commands  
35 to MAP circuitry 304 associated with link transmitter 300 over interface 366. MAP circuitry 304 then maps the M symbols to the appropriate outputs of MAP circuitry 304

-17-

so that the correct subset of M subcarriers is transmitted on.

The necessary data transfer between the mobile stations, base stations and MSCs of the system may be accomplished by known methods. In the described embodiment the DCCH and PCCH channels may be used on both the uplink and downlink to transfer measurement results or subcarrier assignment messages between a mobile station and the system. The use of control channels to carry such information is known to those skilled in the art.

Referring now to FIG. 4A, therein is shown a flow diagram illustrating the steps performed by the link receiver 330 during the ACA process. The steps performed by a mobile station receiving on a downlink and the steps performed by a base station receiving on an uplink are essentially identical and FIG. 4A can be used to describe the steps performed by the link receiver 330 in both cases. The differences between the process steps performed in the mobile station and base station involve step 428 of FIG. 4A. FIG. 4B is a flow diagram that illustrates additional steps performed by the mobile station during step 428 of the ACA measurement process. These extra steps will be described with reference to FIG. 4B as the process of FIG. 4A is described.

The ACA process begins when it is necessary for the system to create a communications link between a mobile station base station pair on either the uplink or the downlink. Referring again to FIG. 4A, at step 402 the link receiver receives from the system a measurement order message to measure interference (I) on each of a group of N subcarriers available for the link. The N subcarriers may be all subcarriers available within the system or a smaller group of subcarriers chosen from all subcarriers available within the system. Next, at step 404 the I measurements are performed. Then, from step 404 the process moves to step 406 where the I measurement results are sent to the system. When a mobile station is the link

-18-

receiver, the I measurement results are transmitted over the DCCH or PCCH channel to the base station and then transferred to the MSC. When a base station is the link receiver, the I measurement results are transferred to the MSC via the appropriate overland means. After transmitting the I measurement results the process moves to step 408 where the link receiver waits for a response from the system. The process steps that take place when the link receiver is in the wait state at step 408 will now be described with reference to FIG. 5.

Referring now to FIG. 5, therein are shown the process steps performed within the ACA processing portion of system during the ACA process. At step 502 the results of the I measurement performed on the N subcarriers at the link receiver are received by the ACA processor. Next, at step 504 the ACA processor determines the M least interfered unused subcarriers from the results of the I measurements made on the N subcarriers. From step 504 the process then moves to step 506 where a subcarrier assignment message assigning the subset of the least interfered M subcarriers to the link is sent to both the link receiver and the link transmitter. The ACA processor now moves to step 508 and waits for further input from the link receiver. The process flow now returns to step 408 FIG. 4A. Alternative methods of determining the M subcarriers for the subcarrier assignment message may be used in place of step 506. For example, the subcarriers could be assigned on the basis of how their use effects transmissions in neighboring cells. If one of the least interfered M subcarriers was used in a neighbor cell, the subcarrier would not be used. In this case the M subcarriers may not be the least interfered M subcarriers.

Referring again to FIG. 4A, the link receiver which has been in the wait state at 408 now moves to step 410 and receives the channel assignment message assigning the subset of M subcarriers to the link. Next, the process moves to step 412 as the link receiver begins receiving

-19-

on the link using the assigned subset of M subcarriers. From step 412 the process now moves to step 414 and waits for further input. At step 416 an input is received. The link receiver may receive three types of inputs while receiving using the assigned subset of M subcarriers. At decision step 418 the link receiver determines if a call end signal has been received. If a call end signal has been received the process ends. The call end signal may have been transmitted by the system to the link receiver or initiated at the link receiver itself. A call end signal indicates to the process that communications on the link have terminated. If a call end has not been received, the process moves to step 420 and the link receiver determines whether a measurement timer message has been received. The measurement timer is contained in the processor associated with the link receiver. The measurement timer generates a measurement message at periodic intervals informing the link receiver to make measurements. Each measurement timer signal defines a measurement interval. If a measurement timer message has been received the process moves to step 424. At step 424 the link receiver measures I on the set of N subcarriers. The I measurements may be averaged with the results of a certain number of previous I measurements for each subcarrier to obtain accuracy. The first time through step 424 the measurements are averaged with the results obtained in step 404. On subsequent passes through step 424 the measurement results are averaged with the last n previous measurements, where n is a value allowing an accurate following of a subcarrier's interference level within the system. From step 424 the process moves to step 426 and the link receiver measures C/I on each of the subset of M carriers. The C/I measurements are also averaged with the last n previous C/I measurements. Then, at step 428 the link receiver sends the I and C/I measurement results to the ACA processing portion of the system. Depending on whether the link receiver is the

-20-

base station or mobile station, step 428 may be performed in differing ways. If the link receiver is a base station the averaged measurement results may be sent directly to the ACA processor. If the link receiver is a mobile station in a downlink the substeps shown in FIG. 4B may be used to reduce signaling traffic as the results are transmitted to the system over the uplink via the base station.

Referring now to FIG. 4B, therein is shown a flow diagram illustrating process substeps performed by a mobile station performing step 428 of FIG. 4A. Signaling traffic on the uplink is reduced by transmitting differing sets of measurement results to the system over differing time intervals. Over long reporting intervals all I measurement and C/I measurement results are transmitted to the system. Over shorter reporting intervals a reduced set of each of the I measurement and C/I measurement results are transmitted. The long and short intervals may be defined so that a long interval occurs every  $n$ th short interval or every  $n$ th measurement period, where  $n$  is a number such as, for example, 25. At step 428a the mobile station determines whether the measurement period involves a short time interval for reporting measurement results. If it is determined that the measurement period involves a short time interval for reporting measurement results the process moves to step 428b, where the mobile station transmits the C/I measurements for the  $Y$  worst quality subcarriers of the subset of  $M$  subcarriers, where  $Y < M$ , and the I measurements for the  $Z$  least interfered of the  $N$  subcarriers to the system, where  $Z < N$ . The values of  $Y$  and  $Z$  are chosen to allow adequate information for effective ACA while minimizing signaling traffic.  $Y$  may be set to 1 and  $Z$  may be set to a number calculated to contain on average the I measurement results of at least one subcarrier not used within the same cell. The process then moves to step 414 where the mobile station waits for further input. However, if, at step 428a, it is

-21-

determined that the measurement period does not involve a short time interval for reporting measurement results the process moves to step 428c. At step 428c the mobile station transmits the C/I measurements for the whole subset of M subcarriers and the I measurements for all N subcarriers to the system. The process then moves to step 414 where the mobile station waits for further input. The process flow now moves to FIG. 5 as the ACA processor receives the measurement results from the link receiver.

Referring again to FIG. 5, the ACA processor which has been in the wait state at step 508, receives an input from the link receiver at step 510. The ACA processor may receive measurement results or a call end signal at step 510. When an input is received the process moves to step 512 where it is determined what type of input was received. If a call end signal is received the process ends. In this example the received message is measurement results so the process moves to step 514. At step 514 the ACA processor determines the subcarrier of the subset of M used subcarriers with the lowest C/I measurement value. Next, at step 516 it is determined if the C/I of the lowest C/I measurement value of the subset of M subcarriers is below the ACA C/I trigger threshold. If, at step 516, it is determined that the lowest C/I measurement value is not below the ACA C/I trigger threshold the process flow will return to step 508 where the ACA processor will wait for further input. If, however, at step 516 it is determined that the lowest C/I measurement value is below the ACA C/I trigger threshold the process flow will instead move to step 518. At step 518 the ACA processor determines whether an unused subcarrier of the set of N subcarriers exists which has an I measurement value less than the I measurement value of the subcarrier of the subset of M with the lowest C/I measurement value. If at step 518 it is determined that no unused subcarrier exists with a lower I measurement value, the process flow will return to step 508 where the



-22-

ACA processor will wait for further input. If, however, at step 518 an unused subcarrier exists with a lower I measurement value, a more preferred subcarrier exists and, the process moves to step 520. At step 520 the ACA processor inserts the least interfered unused subcarrier into the subset of M subcarriers and removes the subcarrier of the subset of M with the lowest C/I measurement value from the subset. To avoid hysteresis effects the change of subcarriers may be performed after calculating a C/I for the least interfered unused subcarrier during step 518 and determining that the calculated C/I is a minimum amount above the C/I of the subcarrier to be removed. If the C/I for the least interfered unused subcarrier is not a minimum amount above the C/I of the subcarrier to be removed the unused subcarrier can be considered not acceptable as a replacement. From step 520 the process moves to step 522 where the system sends a reconfigure subset message to the link receiver instructing the link receiver to reconfigure the subset of M subcarriers assigned to the link to conform to the changes made by the processor. Then the ACA processor moves to step 508 and waits for further input from the link receiver. The procedure given by steps 514-520 could alternately be performed by determining a plurality of less interfered unused subcarriers and exchanging these with a plurality of used subcarriers having an interference level below the C/I threshold. The subset could also be reconfigured according to other criteria. For example, the subset of M could be reconfigured on the basis of the effect of using the subset, in the cell of the link, on communications occurring in neighbor cells. If some of the M subcarriers used in the cell were also used in neighbor cells, these could be replaced with subcarriers unused in the cell and also not used in neighbor cells. Reconfiguration could take place even if the used subcarriers were not below a C/I threshold or even if the

-23-

unused subcarrier had an interference level greater than the replaced subcarriers.

The process continues as long as a call is ongoing and communications on the link continue. The link receiver will next move from the wait state at step 408 upon receiving an input and the process steps shown in FIGS. 4A, 4B and 5 will be repeated until the call ends and a call end signal is received by the link transmitter, link receiver and ACA processing portion of the system.

In an alternative embodiment of the invention, a mobile station as link receiver transmits request messages requesting a certain subset of M subcarriers, or requesting replacements for the M subcarriers, to be used on the link. Signal measurement results need not be transmitted from the mobile station to the system. The system in turn transmits subset accepted or subcarrier accepted messages to the mobile station. The downlink ACA processing mainly takes place in the processor 346 of the receiver in the mobile station. In this alternative embodiment steps 504, 514, 516, 518 and 520 shown in FIG. 5, which are performed by the system in the first embodiment, would be performed by processor 346 in the mobile station. The base station ACA process flow for uplink measurements remains as illustrated in FIGS. 4A, 4B and 5.

Referring now to FIG. 6A, therein is shown a flow diagram illustrating the steps performed by a mobile station as the link receiver during the ACA process of the alternative embodiment of the invention. The ACA process begins when the mobile station receives a measurement order message at Step 602. Next, at Step 604 the interference (I) on each of the group of N subcarriers available for the link is measured at the mobile station. Next, the process moves to Step 606 where the M least interfered subcarriers are determined. From Step 606 the process moves to Step 608 and a subset request message is sent to the system by the mobile station. The subset

-24-

request message indicates to the system that the mobile station requests the use of each subcarrier in the requested subset. The process now moves to Step 610 and the mobile station waits for an answer from the system.

5 The process steps that take place when the process is in the wait state at Step 610 will now be described with reference to FIG. 7.

Referring now to FIG. 7, therein are shown process steps performed within the ACA processing portion of the system according to the alternative embodiment of the invention when the mobile station is involved in the ACA process. At Step 702 the ACA processing portion receives the subset request message. Next, at Step 704 the system determines if the mobile is allowed to use all of the M subcarriers in the requested subset. Certain subcarriers may not be available for use in the cell, for example, if they are being used by another mobile station or, if they have been reserved within the system for special uses. The availability of the M subcarrier may also be determined as to how their use effects transmissions in neighboring cells. The ACA is designed to allow flexibility to the system operators in making these decisions. If it is determined that the mobile station is allowed to use all M subcarriers in the requested subset, the system will transmit a subset accepted message to the link receiver. If however, at Step 704, it is determined that subcarriers of the suggested subset cannot be used by the mobile station, the process moves to Step 720 and the system transmits a subcarrier rejected message rejecting the unavailable subcarriers as part of the subset of M subcarriers. The process flow now moves to Step 722 as the process waits for a reply from the mobile station.

10  
15  
20  
25  
30

Referring now to FIG. 6A, at Step 612 the mobile station receives a subset accepted message or subcarrier rejection message transmitted from the system. If a subset acceptance message is received, the process moves

35

-25-

to Step 620 where the link receiver begins receiving using the assigned subset. If however, at Step 614, it is determined that a subcarrier rejected message(s) has been received, the process moves to Step 616. At Step 616, the link receiver determines the next candidate(s) to replace the rejected requested subcarrier(s). These candidates would be the next least interfered subcarriers of the set of N available subcarriers that are not in the suggested set of M.

From Step 616 the process then moves to Step 618 where a subcarrier request message requesting the next candidate subcarrier(s) is transmitted to the system. The process then moves to Step 610 as the link receiver waits for an answer. The process will continue through the loops formed by the Steps 610, 612, 614, 616, 618, and, 706 and 708, until the complete subset of M subcarriers is accepted. Then the process moves to Step 620 where the mobile station begins receiving on the link using the accepted subset. The process now moves to the wait state of Step 622. When in the wait state of Step 622 the process may receive either a call end or measurement timer message. The call end and measurement timer messages are equivalent to the call end and measurement messages described above for the previous embodiment of the invention. The link receiver receives the call end or measurement timer message at Step 624 and moves to Step 626 where it is determined if a call end was received. If a call end is received the process ends. If, however, a measurement timer message was received, the process moves to Step 628. At Step 628 the mobile station measures I on all N available subcarriers and averages the results for each subcarrier. Next, at Step 630, the link receiver measures C/I on the subset of M subcarriers and averages the results for each subcarrier. The process now moves to Step 632 of FIG. 6B.

At Step 632 the link receiver determines the subcarrier of the subset of M with the lowest C/I. Next,

-26-

at Step 634 it is determined if the lowest C/I is below a threshold. If it is not below the threshold, the process returns to Step 622 where the link receiver waits for another call end or measurement timer message. If, however, it is determined that the lowest C/I is below the threshold C/I, the process moves to Step 636. At Step 636 it is determined if a less interfered subcarrier of the set of N not in the subset of M exists. If a less interfered subcarrier does not exist the process returns to Step 622. If, however, a less interfered subcarrier does exist, a more preferred subcarrier exists and the process moves to Step 638. At Step 638 the mobile station transmits a subcarrier request message to the system requesting the least interfered subcarrier not in the subset of M subcarriers as a replacement for the subcarrier with the lowest C/I. The process within the mobile station now moves to the wait state of Step 640 and the process flow moves to Step 708 of FIG. 7. The ACA processing portion of the system receives the requested subcarrier message at Step 710. The procedure outline in steps 632-638 could alternately be performed by determining a plurality of used subcarriers with the lowest C/Is of the subset and then determining a plurality of less interfered unused subcarriers as requested replacements. After receiving the subcarrier requested message it is determined, at step 716, if the requested subcarrier is used within the cell on a link with another mobile station. If the requested subcarrier is used within the cell the system moves to Step 718 and transmits a requested subcarrier rejected message to the mobile station and the process returns to Step 708. If, however, the suggested replacement is unused within the cell, the system transmits a requested subcarrier accepted message to the mobile station and the process returns to Step 708. As an alternative to determining if the requested subcarrier is used with the cell, other criteria may also be used to determine availability. For example, if the

-27-

requested subcarrier is used in a neighbor cell the system could reject the subcarrier request. The process then moves from the wait state of Step 640 to Step 642 as the mobile station receives the acceptance or rejection message. Next, at Step 644, it is determined if the requested subcarrier was accepted. If the requested subcarrier was accepted the process moves to Step 646 and the mobile station reconfigures the subset of M subcarriers on which the mobile station is receiving to include the requested subcarrier and deletes the subcarrier with the lowest C/I. Then, the process moves to the wait state of Step 622. If, however, the requested subcarrier is not accepted the process moves to Step 648. At Step 648 the mobile station determines if a new candidate subcarrier less interfered than the subcarrier of M subcarriers with the lowest C/I, that has not been already rejected as a requested subcarrier within this measurement interval, exists. If a new candidate subcarrier does not exist the process moves back to the wait state of Step 622. If, however, a new candidate subcarrier does exist, the process moves to Step 638 where the mobile station transmits a subcarrier request message to the system. The message requests the new candidate subcarrier found at Step 648 as the new replacement subcarrier. The process then moves to Step 640 and waits for an answer from the system. The process will continue through the loops formed by Steps 642, 644, 648, 650, and, 638 and 710, 712, 714, and 716 or 718, until a requested subcarrier is accepted or no new candidate exist. The process then moves to the wait state of Step 622. The ACA process will continue throughout the call and be invoked each time a measurement timer message is received. When the call ends, the process will end through Steps 624 and 626.

As can be seen from the above description, the invention provides a method and system of adaptive channel allocation for an OFDM system. Use of the invention will

-28-

enhance the performance of OFDM systems into which it is implemented. The adaptive channel allocation is designed to minimize the signaling resources necessary to carry measurement results on the system uplinks will still  
5 provide the benefits of adaptive channel allocation. The result is a system with better spectral efficiency, less dropped calls and better quality communications for each link.

10 It is believed that the operation and construction of the present invention will be apparent from the foregoing description and, while the invention shown and described herein has been characterized as particular embodiments, changes and modifications may be made therein without departing from the spirit and scope of the  
15 invention as defined in the following claims.

-29-

**WHAT IS CLAIMED IS:**

1. In a telecommunications system in which communications from a link transmitter to a link receiver are transmitted over a subset of a set of a plurality of subcarriers available to a link, a method of allocating subcarriers for communications on a link, said method comprising the steps of:

- 5 allocating a plurality of subcarriers from said set to provide said subset;
- 10 measuring a received signal on each subcarrier of said set;
- determining if at least one unused subcarrier exists in said set that is more preferred for use on said link than a subcarrier of said subset; and
- 15 reconfiguring said subset in response to an affirmative determination.

2. The method of claim 1 in which said step of allocating comprises the steps of:

20 measuring an interference level (I) on each subcarrier of said set; and

determining said subset, said subset comprising a plurality of least interfered unused subcarriers of said set.

25 3. The method of claim 2 in which said step of measuring an interference level (I) further comprises the step of:

30 transmitting a plurality of results of said interference level (I) measurements from said link receiver to said system, wherein the number of said plurality of results transmitted is less than the number of subcarriers in said set.

35 4. The method of claim 1 in which said step of measuring comprises the steps of:



-30-

measuring the interference level (I) on each subcarrier of said set.

5        5.    The method of claim 1 in which said step of measuring comprises the steps of:

          measuring the signal quality (C/I) on each subcarrier of said subset.

10       6.    The method of claim 1 in which said step of measuring comprises the steps of:

          measuring the interference level (I) on each subcarrier of said set; and

          measuring the signal quality level (C/I) on each subcarrier of said subset; and,

15       said step of determining comprises the steps of:

          determining a subcarrier of said subset with a lowest signal quality level (C/I); and

20       determining if an unused subcarrier of said set exists that has an interference level (I) lower than the interference level (I) of said subcarrier of said subset with said lowest signal quality level (C/I).

25       7.    The method of claim 6 in which said step of reconfiguring comprises the steps of:

          removing said subcarrier with said lowest signal quality (C/I) from said subset in response to an affirmative determination; and

30       inserting said unused subcarrier into said subset.

35       8.    The method of claim 6 in which said step of measuring the interference level (I) further comprises the steps of:

          transmitting a plurality of results of said interference level (I) measurements from said link

-31-

receiver to said system, wherein the number of said results transmitted is less than the number of subcarriers in said set; and,

5 said step of measuring the signal quality (C/I) further comprises the steps of:

transmitting a plurality of results of said signal quality (C/I) measurements from said link receiver to said system, wherein the number of said results transmitted is less than  
10 the number of subcarriers in said subset.

9. The method of claim 1 in which said step of allocating comprises the steps of:

15 measuring an interference level (I) on each subcarrier of said set;

determining a candidate subset, said candidate subset comprising a plurality of least interfered subcarriers of said set;

20 transmitting a subset request message from said link receiver to said system;

receiving an answer message from said system at said link receiver; and

25 determining whether said candidate subset is accepted for said link from said answer message.

10. The method of claim 9 in which said step of receiving an answer message comprises receiving a subset accepted message.

30 11. The method of claim 9 in which said step of receiving an answer message comprises receiving one or more subcarrier rejected messages, and said step of determining whether said candidate subset is accepted further comprises the steps of:

35 determining one or more next candidate subcarriers for said subset;

-32-

transmitting one or more subcarrier requested messages from said link receiver to said system; and repeating said steps of determining one or more next candidate subcarriers and transmitting one or more subcarrier requested messages to said system until a complete subset is accepted.

12. The method of claim 1 in which said step of determining if an unused subcarrier exists comprises the steps of:

determining if a candidate subcarrier of said set exists that is more preferred for use on said link than a subcarrier of said subset;  
transmitting a subcarrier request message from said link receiver to said system;  
receiving an answer from said system at said link receiver;  
determining from said answer if said candidate subcarrier is unused; and  
repeating, in response to a negative determination, the steps of determining if a subcarrier of said set exists that is more preferred, transmitting a subcarrier request, receiving an answer, and determining from said answer, each time with a different candidate subcarrier, until said step of determining from said answer results in an affirmative determination.

13. The method of claim 12 in which said step of measuring a received signal on each subcarrier of said subset comprises the steps of:

measuring the interference level (I) on each subcarrier of said set; and  
measuring the signal quality level (C/I) on each subcarrier of said subset; and  
said step of determining if a candidate subcarrier exists in said set that is more preferred

-33-

for use on said link than a subcarrier of said subset comprises the steps of:

determining a subcarrier of said subset with a lowest signal quality level (C/I); and

5 determining a candidate subcarrier of said set that has an interference level (I) lower than the interference level (I) of said subcarrier of said subset with said lowest signal quality level (C/I).

10

14. In a telecommunications network in which communications from a link transmitter to a link receiver are transmitted over a subset of a set of a plurality of subscribers available to a link, a system for allocating subcarriers for communications on a link, said system

15

comprising:

means for allocating a plurality of subcarriers from said set to provide said subset;

20

means for measuring a received signal on each subcarrier of said subset;

means for determining if at least one unused subcarrier exists in said set that is more preferred for use on said link than a subcarrier of said subset; and

25

means for reconfiguring said subset in response to an affirmative determination.

15. The system of claim 14 in which said means for allocating comprises:

30

means for measuring an interference level (I) on each subcarrier of said set; and

means for determining a subset, said subset comprising a plurality of least interfered subcarriers of said set.

35

16. The system of claim 15 in which said means for measuring an interference level (I) further comprises:

-34-

means for transmitting a plurality of results of said interference level (I) measurements from said link receiver to said system, wherein the number of said plurality of results transmitted is less than the number of subcarriers in said set.

5

17. The system of claim 14 in which said means for measuring comprises:

10

means for measuring the interference level (I) on each of subcarriers of said set.

18. The system of claim 14 in which said means for measuring comprises:

15

means for measuring the signal quality (C/I) on each subcarriers of said subset.

19. The system of claim 14 in which said means for measuring comprises:

20

means for measuring the interference level (I) on each subcarrier of said set; and

means for measuring the signal quality level (C/I) on each subcarrier of said subset; and,

said means for determining comprises:

25

means for determining a subcarrier of said subset with a lowest signal quality level (C/I); and

30

means for determining if an unused subcarrier of said set exists that has an interference level (I) lower than the interference level (I) of said subcarrier of said subset with said lowest signal quality level (C/I).

20. The system of claim 19 in which said means for reconfiguring comprises:

35

-35-

means for removing said subcarrier with said lowest signal quality (C/I) from said subset in response to an affirmative determination; and

5 means for inserting said unused subcarrier into said subset.

21. The system of claim 19 in which said means for measuring the interference level (I) further comprises:

10 means for transmitting a plurality of results of said interference level (I) measurements from said link receiver to said system, wherein the number of said results transmitted is less than the number of subcarriers in said set; and,

15 said means for measuring the signal quality (C/I) further comprises:

means for transmitting a plurality of results of said signal quality (C/I) measurements from said link receiver to said system, wherein the number of said results transmitted is less than the number of subcarriers in said subset.

20

22. The method of claim 14 in which said means for allocating comprises:

25 means for measuring an interference level (I) on each subcarrier of said set;

means for determining a candidate subset, said candidate subset comprising a plurality of least interfered subcarriers of said set;

30 means for transmitting a subset request message from said link receiver to said system;

means for receiving an answer message from said system at said link receiver; and

35 means for determining whether said candidate subset is accepted for said link from said answer message.

-36-

23. The system of claim 22 in which said means for receiving an answer message comprises means for receiving a subset accepted message.

5           24. The system of claim 22 in which the means for receiving an answer message comprises means for receiving one or more subcarrier rejected messages, and said means for determining whether said candidate subset is accepted further comprises:

10                 means for determining one or more next candidate subcarriers for said subset;

                  means for transmitting one or more subcarrier requested messages from said link receiver to said system; and

15                 means for repeating said steps of determining one or more next candidate subcarriers and transmitting one or more subcarrier requested messages to said system until a complete subset is accepted.

20           25. The method of claim 14 in which said means for determining if an unused subcarrier exists comprises:

                  means for determining if a candidate subcarrier of said set that is more preferred for use on said link than a subcarrier of said subset;

25                 means for transmitting a subcarrier request message from said link receiver to said system;

                  means for receiving an answer from said system at said link receiver; and

30                 means for determining from said answer if said candidate subcarrier is unused.

                  26. The method of claim 25 in which said means for measuring a received signal on each subcarrier of said subset comprises:

                  means for measuring the interference level (I) on each subcarrier of said set; and

-37-

means for measuring the signal quality level (C/I) on each subcarrier of said subset; and

5 said means for determining if a candidate subcarrier exists in said set that is more preferred for use on said link than a subcarrier of said subset comprises:

means for determining a subcarrier of said subset with a lowest signal quality level (C/I); and

10 means for determining a candidate subcarrier of said set that has an interference level (I) lower than the interference level (I) of said subcarrier of said subset with said lowest signal quality level (C/I).



1 / 11

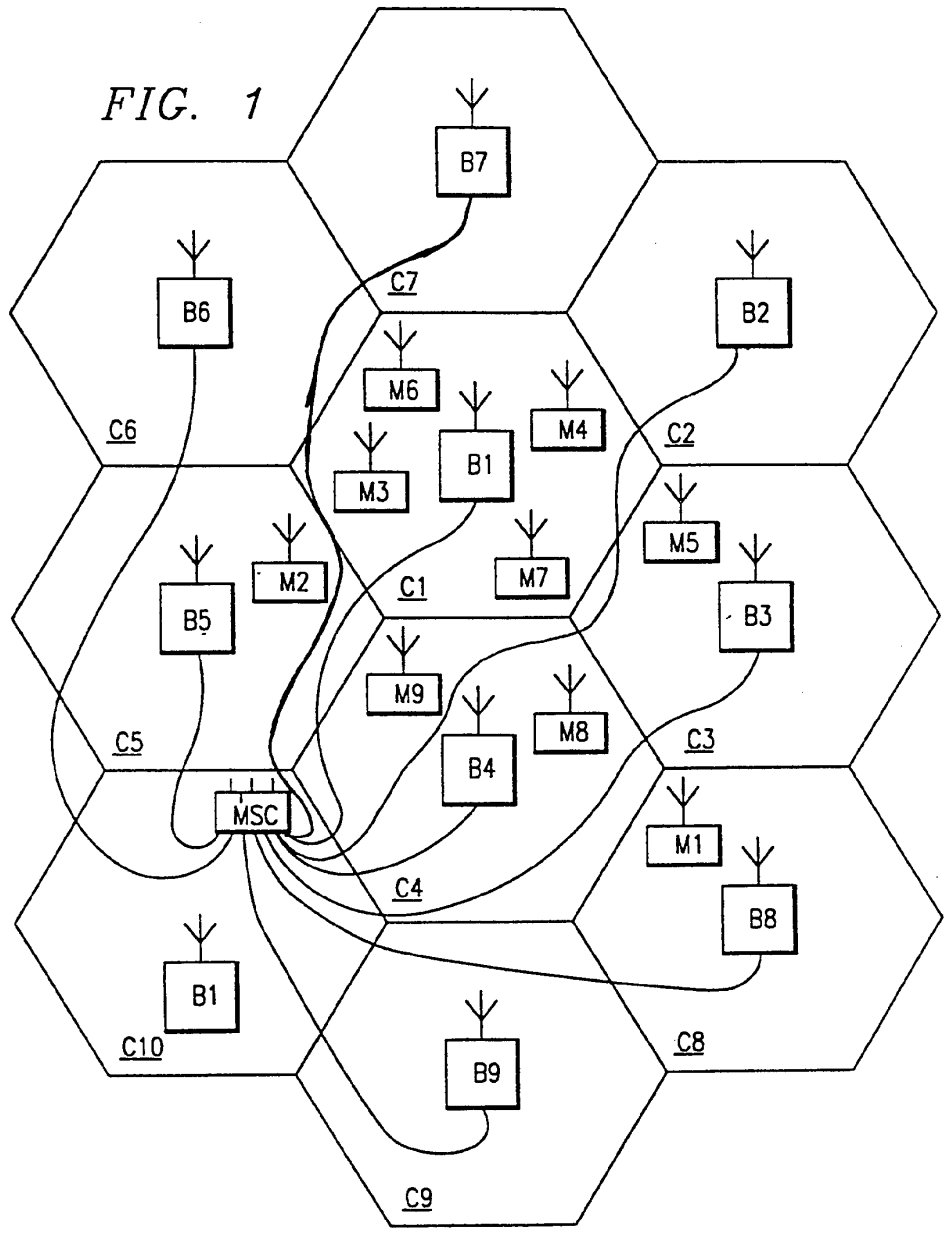

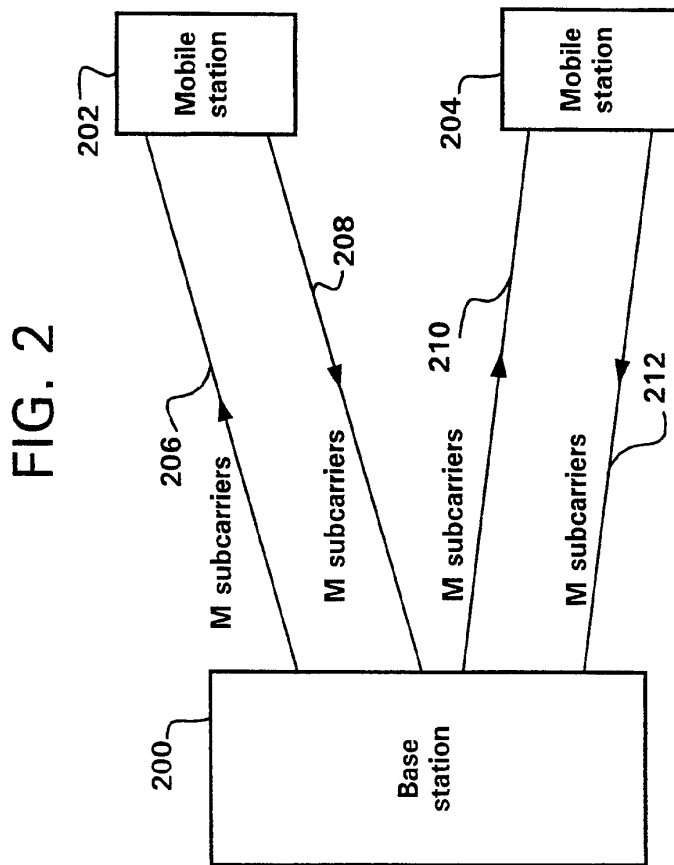

FIG. 3A

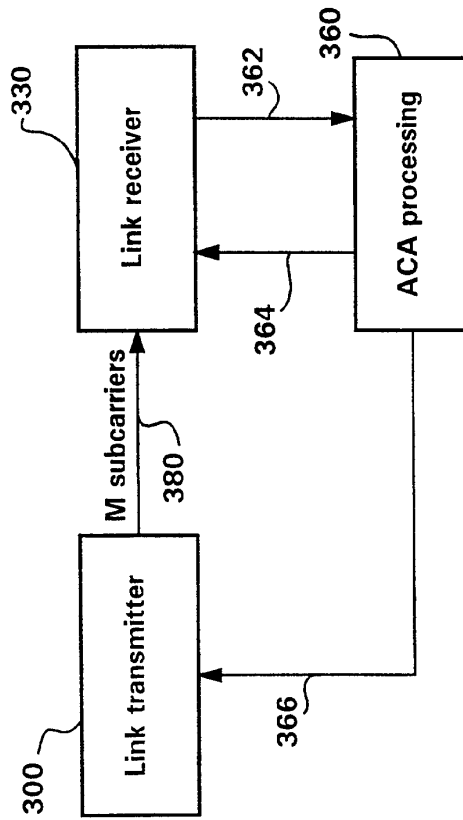

FIG. 3B

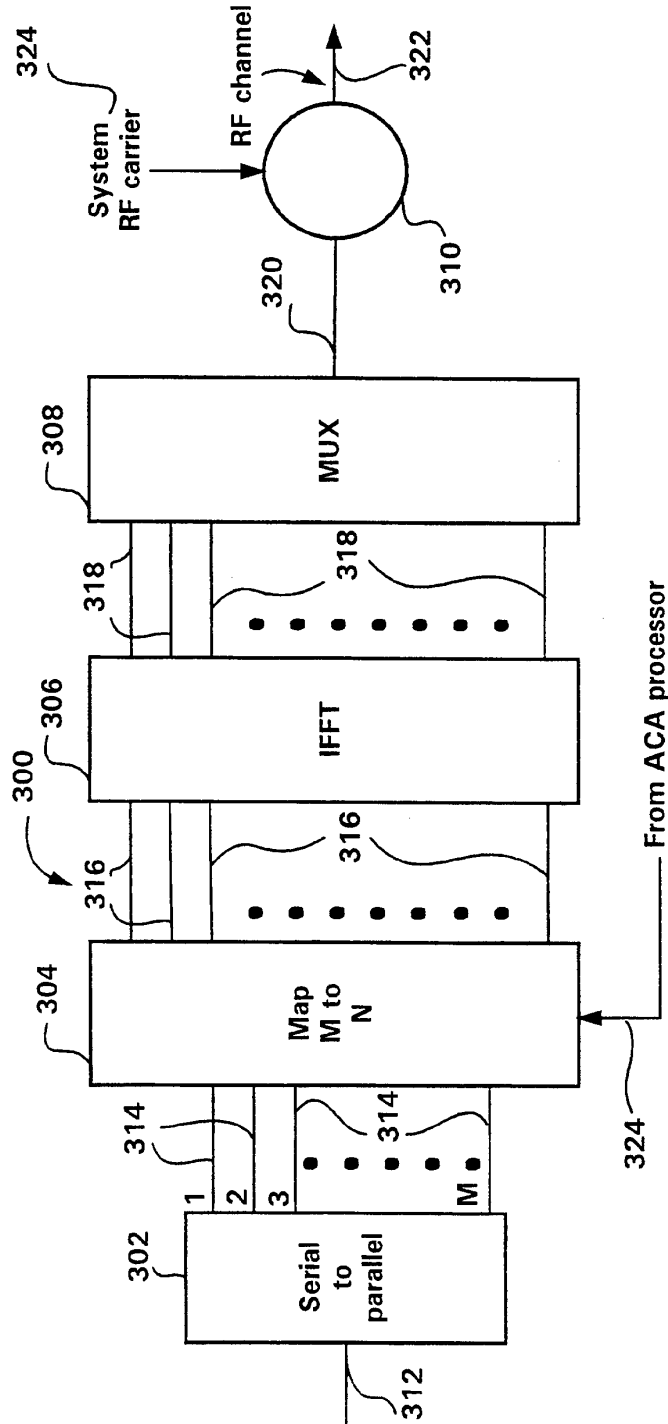
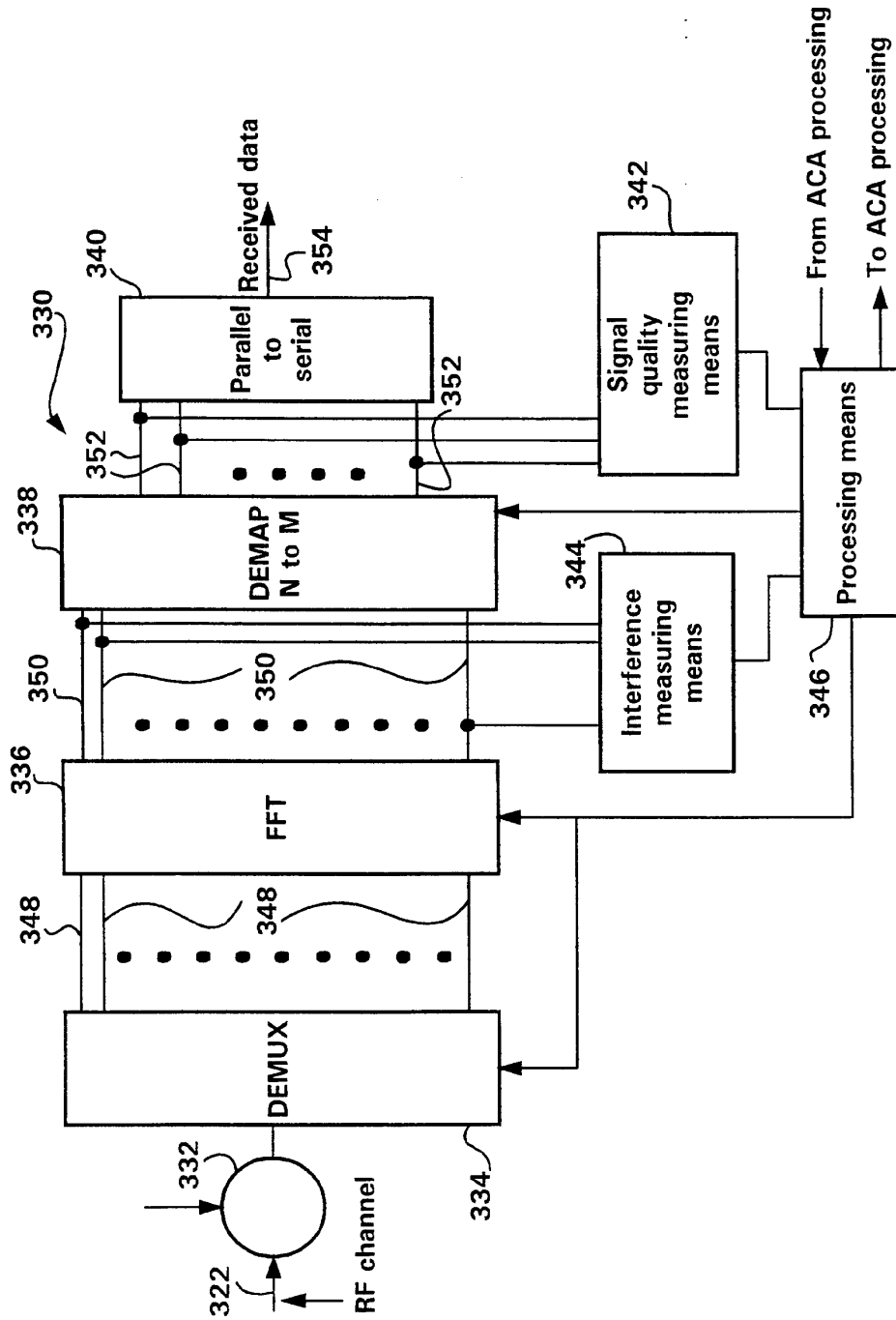

FIG. 3C



6 / 11

FIG. 4A

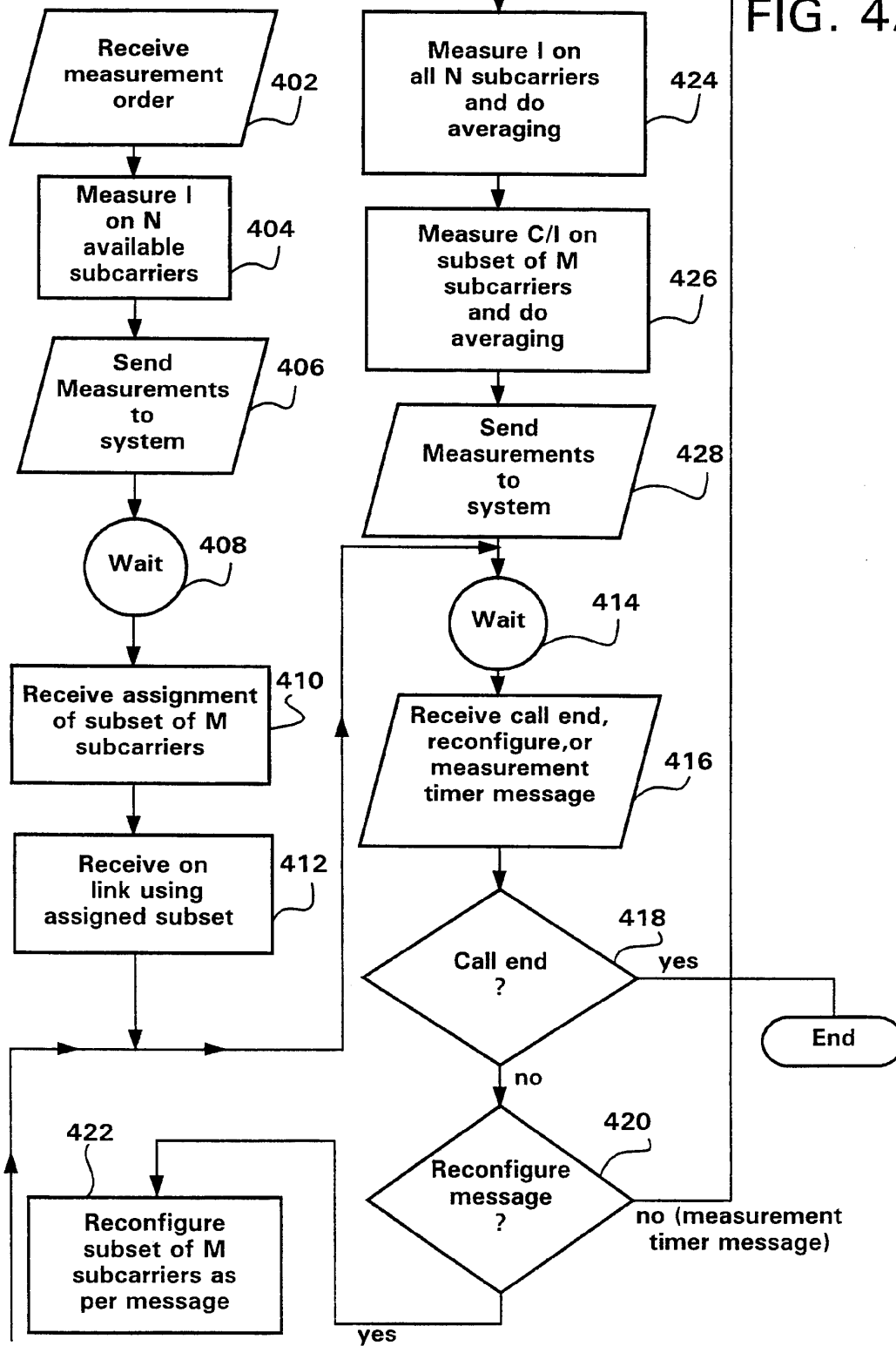

FIG. 4B

From step 426 of fig. 4a

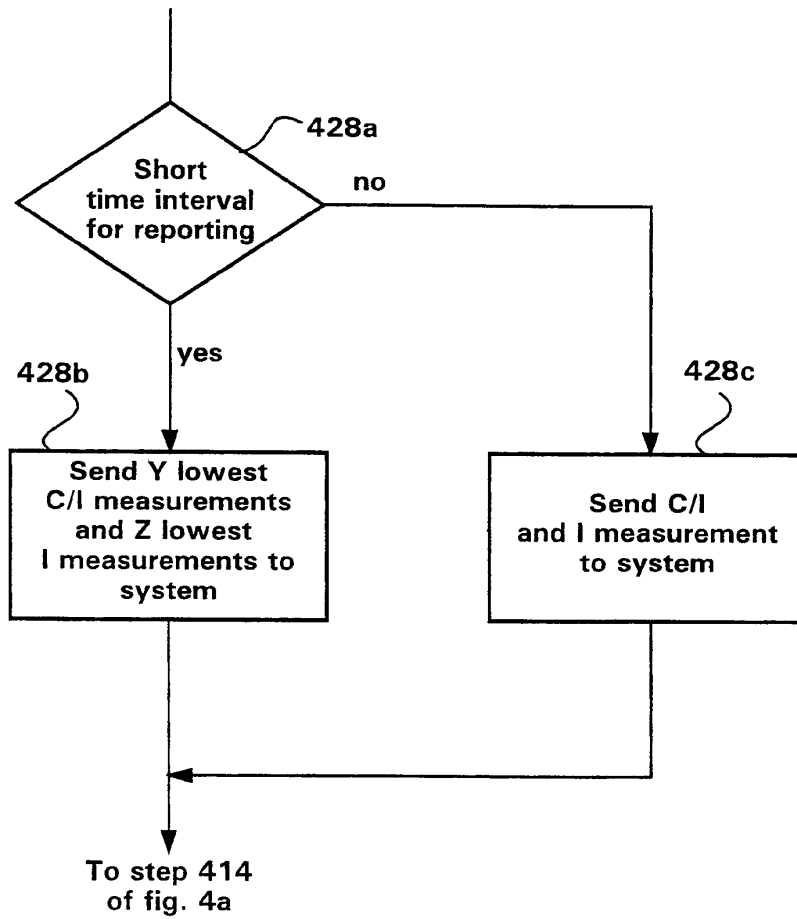
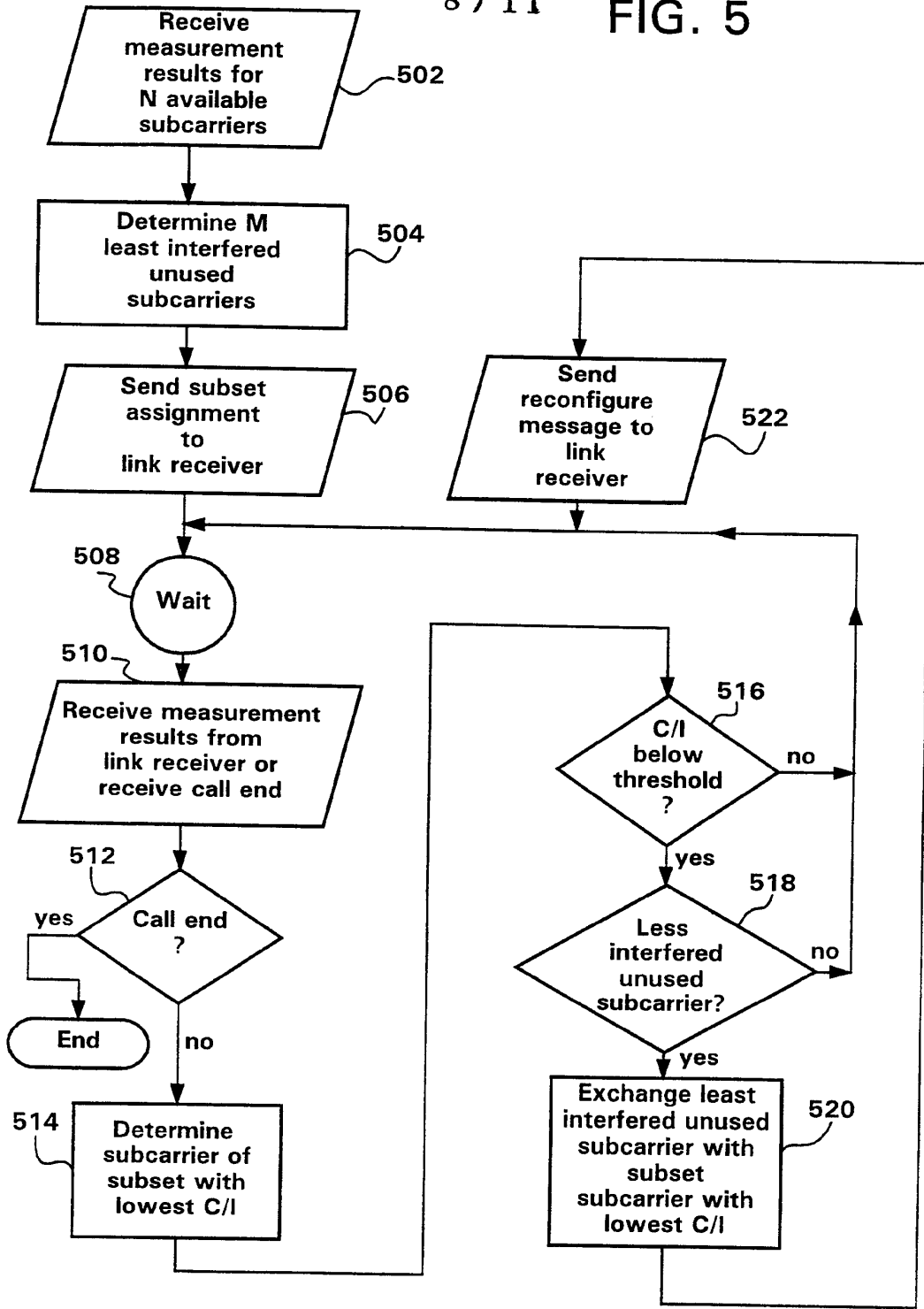

FIG. 5





9/11

FIG. 6A

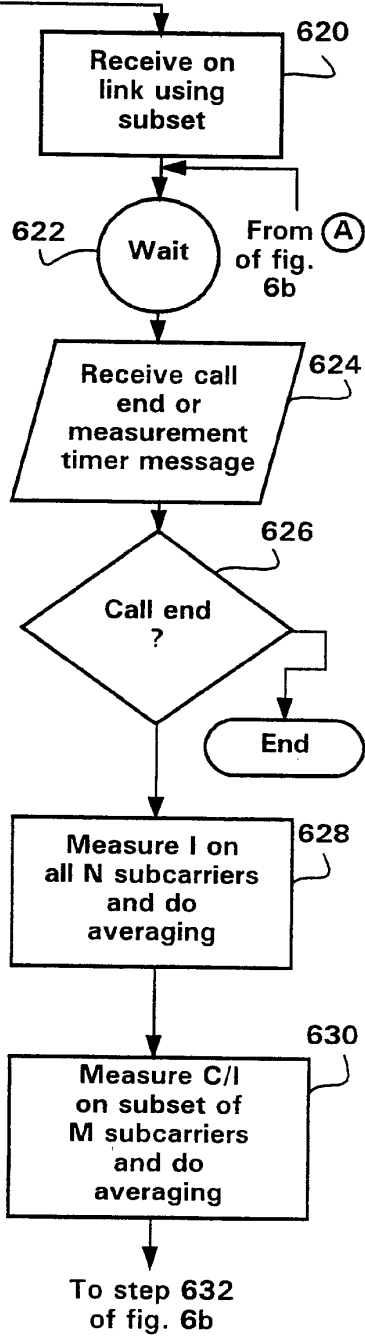
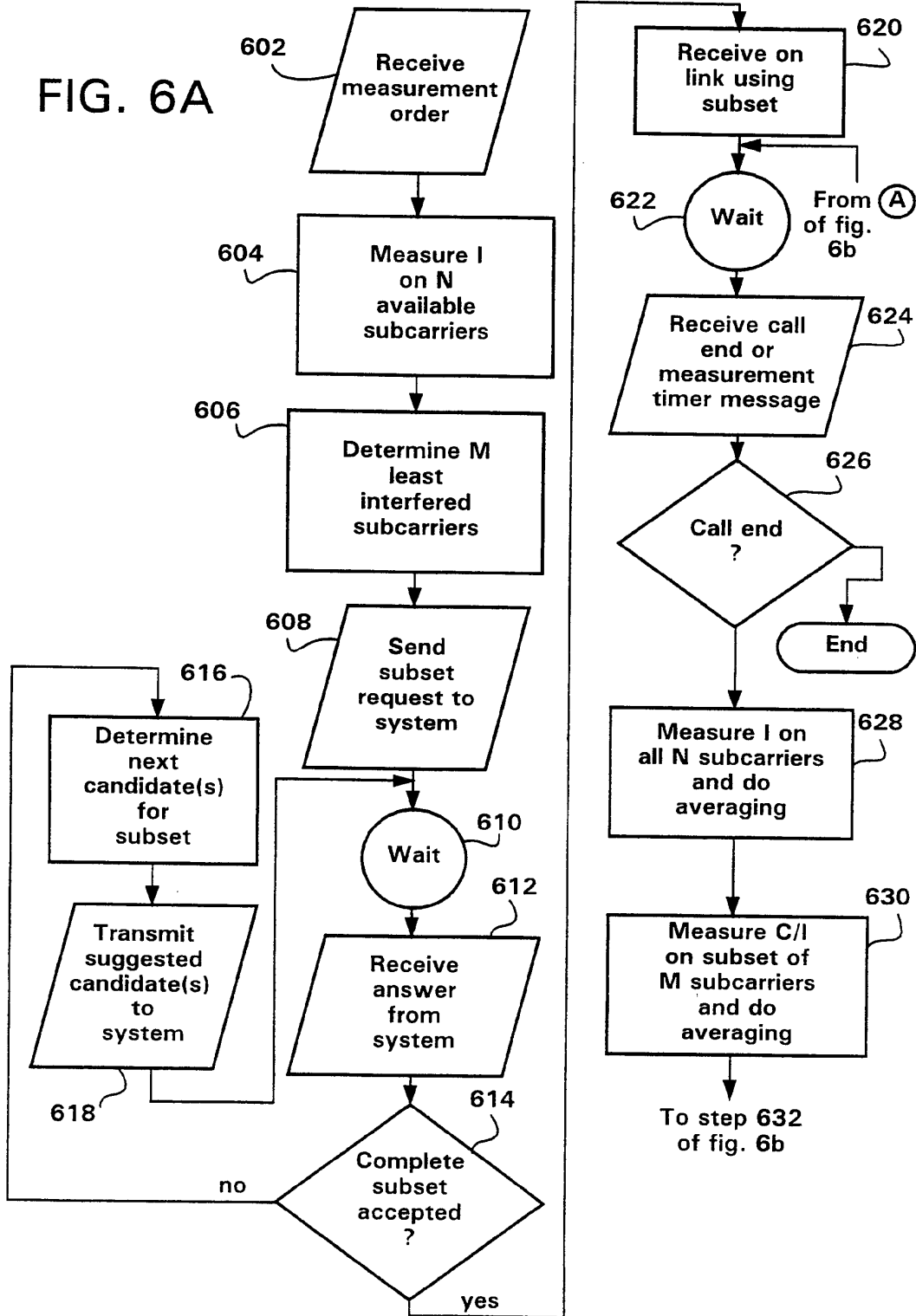

10/11

From step 630 of fig. 6a

FIG. 6B

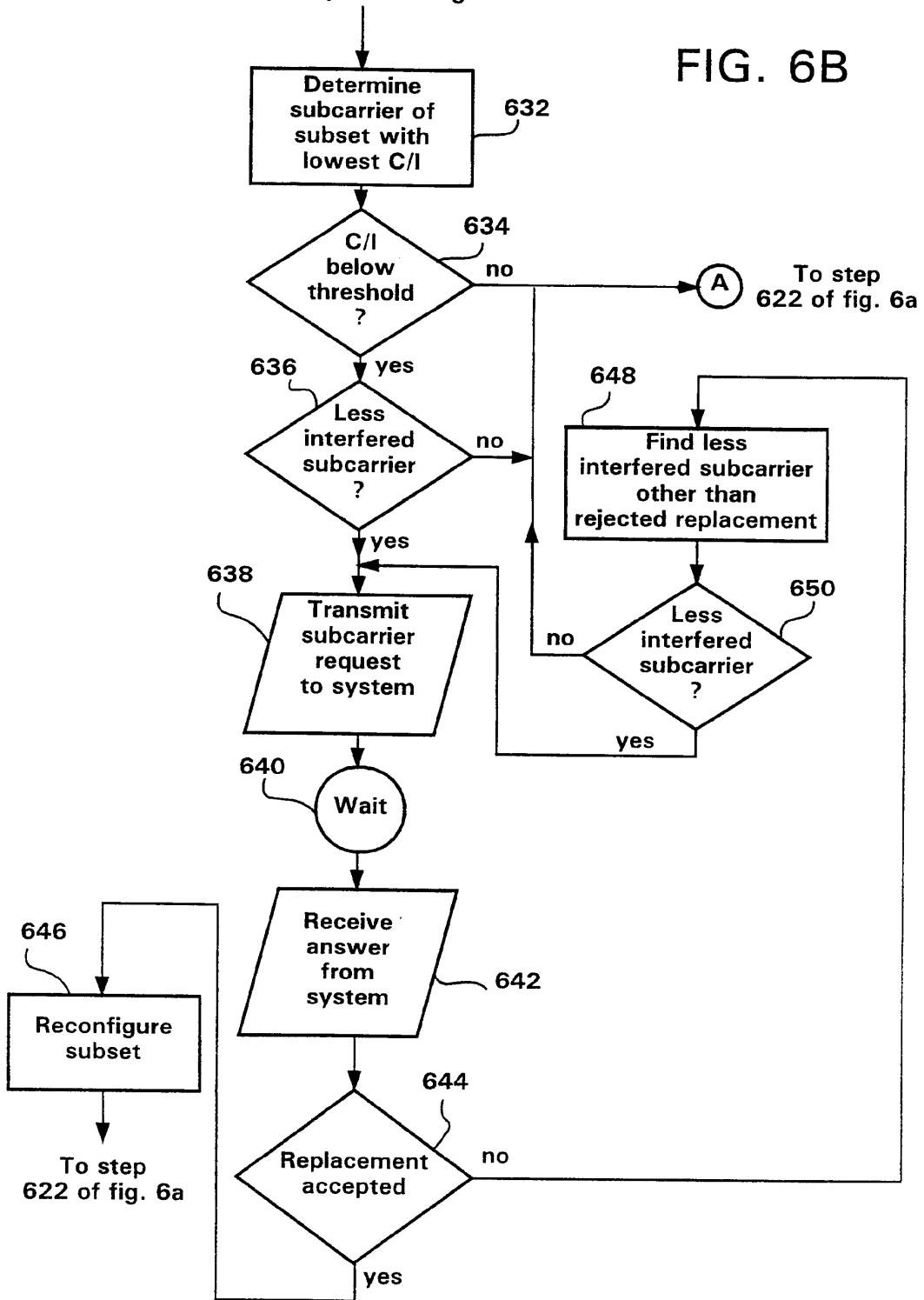
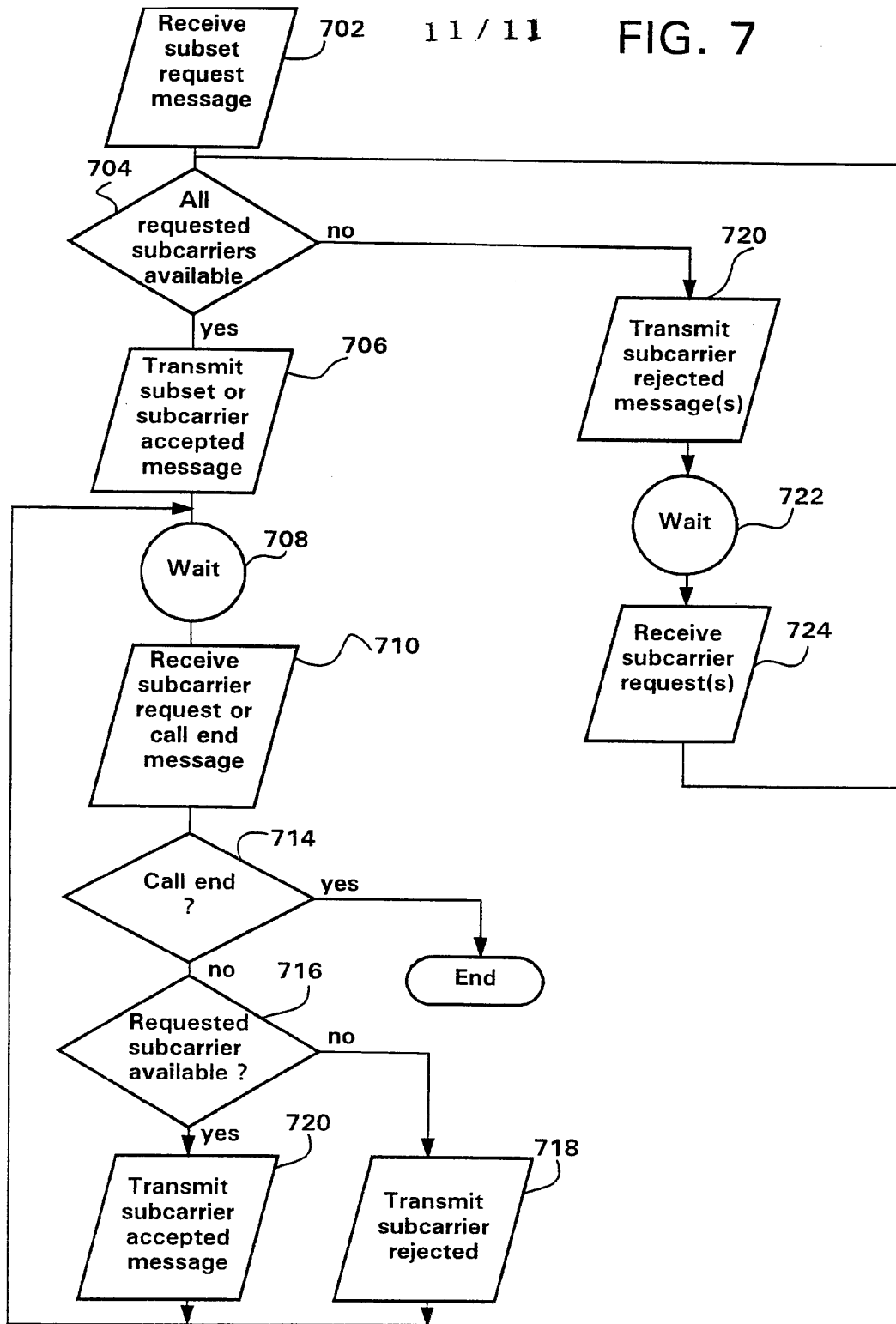

FIG. 7



# INTERNATIONAL SEARCH REPORT

International Application No  
PCT/SE 96/00814

<b>A. CLASSIFICATION OF SUBJECT MATTER</b> IPC 6 H04Q7/38 H04L5/06		
According to International Patent Classification (IPC) or to both national classification and IPC		
<b>B. FIELDS SEARCHED</b> Minimum documentation searched (classification system followed by classification symbols) IPC 6 H04Q H04L		
Documentation searched other than minimum documentation to the extent that such documents are included in the fields searched		
Electronic data base consulted during the international search (name of data base and, where practical, search terms used)		
<b>C. DOCUMENTS CONSIDERED TO BE RELEVANT</b>		
Category *	Citation of document, with indication, where appropriate, of the relevant passages	Relevant to claim No.
X	WO,A,95 10144 (TELIA AB ;ENGSTROEM BO (SE); LARSSON ROGER (SE)) 13 April 1995 see the whole document ---	1-10, 14-23
A	US,A,5 295 138 (GREENBERG A FREDERICK ET AL) 15 March 1994 see claims ---	1-26
A	US,A,5 400 322 (HUNT RONALD R ET AL) 21 March 1995  see column 1, line 31 - column 3, line 63 ---	1-5, 8-10, 14-18, 21-23
A	EP,A,0 637 181 (SIEMENS AG) 1 February 1995 see the whole document --- -/--	1-5, 14-18
<input checked="" type="checkbox"/> Further documents are listed in the continuation of box C.		
<input checked="" type="checkbox"/> Patent family members are listed in annex.		
* Special categories of cited documents :		
'A' document defining the general state of the art which is not considered to be of particular relevance 'E' earlier document but published on or after the international filing date 'L' document which may throw doubts on priority claim(s) or which is cited to establish the publication date of another citation or other special reason (as specified) 'O' document referring to an oral disclosure, use, exhibition or other means 'P' document published prior to the international filing date but later than the priority date claimed	'T' later document published after the international filing date or priority date and not in conflict with the application but cited to understand the principle or theory underlying the invention 'X' document of particular relevance; the claimed invention cannot be considered novel or cannot be considered to involve an inventive step when the document is taken alone 'Y' document of particular relevance; the claimed invention cannot be considered to involve an inventive step when the document is combined with one or more other such documents, such combination being obvious to a person skilled in the art. '&' document member of the same patent family	
Date of the actual completion of the international search	Date of mailing of the international search report	
22 October 1996	1 2. 11. 96	
Name and mailing address of the ISA European Patent Office, P.B. 5818 Patentlaan 2 NL - 2280 HV Rijswijk Tel. (+ 31-70) 340-2040, Tx. 31 651 epo nl, Fax (+ 31-70) 340-3016	Authorized officer  Janyszek, J-M	

INTERNATIONAL SEARCH REPORT

International Application No  
 PC1/SE 96/00814

C.(Continuation) DOCUMENTS CONSIDERED TO BE RELEVANT		
Category	Citation of document, with indication, where appropriate, of the relevant passages	Relevant to claim No.
A	ELECTRONICS LETTERS, 27 OCT. 1994, UK, vol. 30, no. 22, ISSN 0013-5194, pages 1831-1832, XP000490811 CHAN C -K ET AL: "Efficient frequency assignment scheme for intermodulation distortion reduction in fibre-optic microcellular systems" see the whole document ---	1-7, 14-18,20
A	EP,A,0 490 509 (NORTHERN TELECOM LTD) 17 June 1992 see the whole document -----	1-8, 14-22

2

**INTERNATIONAL SEARCH REPORT**

Information on patent family members

International Application No

PCT, SE 96/00814

Patent document cited in search report	Publication date	Patent family member(s)	Publication date
WO-A-9510144	13-04-95	SE-C- 503548	01-07-96
		EP-A- 0721705	17-07-96
		SE-A- 9303213	02-04-95
-----			
US-A-5295138	15-03-94	NONE	
-----			
US-A-5400322	21-03-95	NONE	
-----			
EP-A-0637181	01-02-95	DE-A- 4325190	02-02-95
		FI-A- 943525	28-01-95
-----			
EP-A-0490509	17-06-92	CA-A- 2032325	15-06-92
		US-A- 5239676	24-08-93
-----			

**PCT** WELTORGANISATION FÜR GEISTIGES EIGENTUM  
 Internationales Büro  
 INTERNATIONALE ANMELDUNG VERÖFFENTLICHT NACH DEM VERTRAG ÜBER DIE  
 INTERNATIONALE ZUSAMMENARBEIT AUF DEM GEBIET DES PATENTWESENS (PCT)



<b>(51) Internationale Patentklassifikation<sup>6</sup> :</b> <b>H04L 5/14</b>	<b>A1</b>	<b>(11) Internationale Veröffentlichungsnummer: WO 97/01900</b>  <b>(43) Internationales Veröffentlichungsdatum:</b> 16. Januar 1997 (16.01.97)																																			
<b>(21) Internationales Aktenzeichen:</b> PCT/AT96/001112 <b>(22) Internationales Anmeldedatum:</b> 21. Juni 1996 (21.06.96)  <b>(30) Prioritätsdaten:</b> A 1087/95                      26. Juni 1995 (26.06.95)                      AT  <b>(71) Anmelder (für alle Bestimmungsstaaten ausser US):</b> ERICSSON AUSTRIA AG [AT/AT]; Pottendorfer Strasse 25-27, A-1121 Wien (AT).  <b>(72) Erfinder; und</b> <b>(75) Erfinder/Anmelder (nur für US):</b> PFIEFFER, Johann [AT/AT]; Siedlungsstrasse 19, A-3804 Allentsteig (AT).  <b>(74) Anwalt:</b> GIBLER, Ferdinand; Dorotheergasse 7, A-1010 Wien (AT).		<b>(81) Bestimmungsstaaten:</b> AL, AM, AT, AU, AZ, BB, BG, BR, BY, CA, CH, CN, CZ, DE, DK, EE, ES, FI, GB, GE, HU, IL, IS, JP, KE, KG, KP, KR, KZ, LK, LR, LS, LT, LU, LV, MD, MG, MK, MN, MW, MX, NO, NZ, PL, PT, RO, RU, SD, SE, SG, SI, SK, TJ, TM, TR, TT, UA, UG, US, UZ, VN, ARIPO Patent (KE, LS, MW, SD, SZ, UG), eurasisches Patent (AM, AZ, BY, KG, KZ, MD, RU, TJ, TM), europäisches Patent (AT, BE, CH, DE, DK, ES, FI, FR, GB, GR, IE, IT, LU, MC, NL, PT, SE), OAPI Patent (BF, BJ, CF, CG, CI, CM, GA, GN, ML, MR, NE, SN, TD, TG).  <b>Veröffentlicht</b> <i>Mit internationalem Recherchenbericht.          Vor Ablauf der für Änderungen der Ansprüche zugelassenen Frist. Veröffentlichung wird wiederholt falls Änderungen eintreffen.</i>																																			
<b>(54) Title:</b> METHOD OF BI-DIRECTIONAL DATA TRANSMISSION OVER A TWO-WIRE LINE  <b>(54) Bezeichnung:</b> VERFAHREN ZUR BIDIREKTIONALEN DATENÜBERTRAGUNG ÜBER EINE ZWEIDRAHTLEITUNG																																					
<table style="margin: auto; border-collapse: collapse;"> <tr> <td style="border-top: 1px solid black; border-bottom: 1px solid black; padding: 5px 10px;">CONTROL</td> <td style="border-top: 1px solid black; border-bottom: 1px solid black; padding: 5px 10px; text-align: center;">downstream</td> <td style="border-top: 1px solid black; border-bottom: 1px solid black; padding: 5px 10px; text-align: center;">VIDEO</td> <td style="border-top: 1px solid black; border-bottom: 1px solid black; padding: 5px 10px; text-align: center;">29</td> <td style="border-top: 1px solid black; border-bottom: 1px solid black; padding: 5px 10px; text-align: center;">30</td> <td style="border-top: 1px solid black; border-bottom: 1px solid black; padding: 5px 10px;">CONTROL</td> <td style="border-top: 1px solid black; border-bottom: 1px solid black; padding: 5px 10px; text-align: center;">upstream</td> </tr> <tr> <td style="padding: 5px 10px; text-align: center;">0</td> <td></td> <td></td> <td></td> <td></td> <td></td> <td></td> </tr> <tr> <td style="padding: 5px 10px; text-align: center;">525 µs</td> <td style="padding: 5px 10px; text-align: center;">525 µs</td> <td style="padding: 5px 10px; text-align: center;">20.625 ms</td> <td></td> <td></td> <td></td> <td></td> </tr> <tr> <td style="padding: 5px 10px; text-align: center;">DV</td> <td style="padding: 5px 10px; text-align: center;">DV</td> <td></td> <td></td> <td></td> <td></td> <td></td> </tr> <tr> <td style="padding: 5px 10px; text-align: center;">back</td> <td style="padding: 5px 10px; text-align: center;">back</td> <td></td> <td></td> <td></td> <td></td> <td></td> </tr> </table>			CONTROL	downstream	VIDEO	29	30	CONTROL	upstream	0							525 µs	525 µs	20.625 ms					DV	DV						back	back					
CONTROL	downstream	VIDEO	29	30	CONTROL	upstream																															
0																																					
525 µs	525 µs	20.625 ms																																			
DV	DV																																				
back	back																																				
<b>(57) Abstract</b> <p>Proposed is a method of bi-directional data transmission over a two-wire line. Digital data destined for transmission or reception, e.g. using discrete multitone modulation (DMT), are modulated or demodulated as appropriate and separated by time-division multiplexing. The appropriate multiplex time frame is subdivided into a predetermined number N of time slots and a number K of those time slots is assigned exclusively to one direction, e.g. transmission, the remaining time slots (= N-K in number) being assigned exclusively to the other direction (e.g. reception).</p>																																					
<b>(57) Zusammenfassung</b> <p>Verfahren zur bidirektionalen Datenübertragung über eine Zweidrahtleitung, wobei digitale Daten zum Senden oder Empfangen, z.B. mittels diskreter Mehrtonmodulation (DMT), moduliert bzw. demoduliert und die zu sendenden und zu empfangenden Daten durch Zeitmultiplexbetrieb getrennt werden, wobei der zugehörige Multiplex-Zeitrahmen in eine vorbestimmbare Anzahl N von Zeitschlitzen unterteilt wird, und davon eine Anzahl K von Zeitschlitzen ausschließlich einer Übertragungsrichtung, z.B. Senden, und die restliche Anzahl (N-K) von Zeitschlitzen ausschließlich der anderen Übertragungsrichtung, z.B. Empfangen, zugeordnet wird.</p>																																					

**LEDIGLICH ZUR INFORMATION**

Codes zur Identifizierung von PCT-Vertragsstaaten auf den Kopfbögen der Schriften, die internationale Anmeldungen gemäss dem PCT veröffentlichen.

AM	Armenien	GB	Vereinigtes Königreich	MX	Mexiko
AT	Österreich	GE	Georgien	NE	Niger
AU	Australien	GN	Guinea	NL	Niederlande
BB	Barbados	GR	Griechenland	NO	Norwegen
BE	Belgien	HU	Ungarn	NZ	Neuseeland
BF	Burkina Faso	IE	Irland	PL	Polen
BG	Bulgarien	IT	Italien	PT	Portugal
BJ	Benin	JP	Japan	RO	Rumänien
BR	Brasilien	KE	Kenya	RU	Russische Föderation
BY	Belarus	KG	Kirgisistan	SD	Sudan
CA	Kanada	KP	Demokratische Volksrepublik Korea	SE	Schweden
CF	Zentrale Afrikanische Republik	KR	Republik Korea	SG	Singapur
CG	Kongo	KZ	Kasachstan	SI	Slowenien
CH	Schweiz	LI	Liechtenstein	SK	Slowakei
CI	Côte d'Ivoire	LK	Sri Lanka	SN	Senegal
CM	Kamerun	LR	Liberia	SZ	Swasiland
CN	China	LK	Litauen	TD	Tschad
CS	Tschechoslowakei	LU	Luxemburg	TG	Togo
CZ	Tschechische Republik	LV	Lettland	TJ	Tadschikistan
DE	Deutschland	MC	Monaco	TT	Trinidad und Tobago
DK	Dänemark	MD	Republik Moldau	UA	Ukraine
EE	Estland	MG	Madagaskar	UG	Uganda
ES	Spanien	ML	Mali	US	Vereinigte Staaten von Amerika
FI	Finnland	MN	Mongolei	UZ	Usbekistan
FR	Frankreich	MR	Mauretanien	VN	Vietnam
GA	Gabon	MW	Malawi		



### **Verfahren zur bidirektionalen Datenübertragung über eine Zweidrahtleitung**

Die Erfindung betrifft ein Verfahren zur bidirektionalen Datenübertragung über eine Zweidrahtleitung, wobei digitale Daten zum Senden oder Empfangen, z.B. mittels diskreter Mehrtonmodulation (DMT), moduliert bzw. demoduliert und die zu sendenden und zu empfangenden Daten, z.B. durch Frequenzmultiplexbetrieb (FDM) oder Echoauslöschung (EC), getrennt werden.

Um störende Beeinflussung von zu übermittelnden Daten zu beseitigen, führen bekannte Verfahren dieser Art die Trennung der z.B. DMT-modulierten Daten im Frequenzmultiplexbetrieb (FDM) durch, wobei unterschiedliche Frequenzbereiche für die beiden Übertragungsrichtungen festgelegt sind. Eine weitere Möglichkeit zur Trennung besteht in der Anwendung des Echoauslöschungsverfahrens (EC), bei dem durch den Einsatz adaptiver Filter der Einfluß des Sendeteils auf den Empfänger durch adaptive Filter unterdrückt wird. Andere Trennverfahren wurden im Stand der Technik in diesem Zusammenhang bisher nicht verwendet.

Das FDM-Verfahren erzeugt bei der Übertragung entsprechend den beiden Übertragungsrichtungen ein unteres und ein oberes Frequenzband. Da aber die Kabeldämpfung frequenzabhängig ist, bereitet es große Schwierigkeiten für beide Übertragungskanäle die gleiche Übertragungsqualität zu erzielen, in den überwiegenden Fällen ist die Übertragungsqualität in eine besser als in die andere Richtung. Generell ist es aber erwünscht, eine möglichst gleiche Qualität für beide Kanäle anbieten zu können. Weiters ist bei FDM die Variation der Übertragungskapazität mit erheblichem Aufwand verbunden, da dafür eine Anpassung der jeweils verwendeten Bandfilter erforderlich ist, sodaß die Kanalbandbreite entsprechend erhöht oder erniedrigt werden kann.

Das weiters aus dem Stand der Technik bekannte Echoauslöschungs-Verfahren weist ebenso wenn auch anders geartete Nachteile auf. So ist bei diesem Verfahren das Nah-Nebensprechen ein großes technisches Problem, da der Signalabstand zwischen Sende- und Empfangssignal sehr groß ist. Es müssen daher sehr hohe Anforderungen an die bei den Sende- und Empfangsteilen vorgesehenen A/D-Wandler erfüllt werden, da Sende- und Empfangssignale gleichzeitig auftreten und diese entsprechend gut getrennt werden müssen. Die hohen Pegelunterschiede der Sende- und Empfangssignale erfordern eine dementsprechend hohe Auflösung der A/D-Wandler, die wiederum höhere Produktkosten zur Folge hat.

Für die Durchführung dieser bekannten Trennmethode FDM und Echoauslöschung ist auch eine relativ hohe Rechnerleistung erforderlich, die die Kosten für die Datenübertragung stark erhöhen. Besonders bei Anwendung in Fällen, in denen wie etwa bei ADSL (Asymmetric Digital Subscriber Line) in einer Übertragungsrichtung ("downstream") große Datenraten von einer zentralen Datenanlage zu einem an der Peripherie gelegenen Teilnehmer und vergleichsweise geringe Datenraten in die andere Übertragungsrichtung ("upstream")

übermittelt werden sollen, ist der bei diesen bekannten Datenübertragungsverfahren getriebene Aufwand nur einer schlechten Nutzung unterworfen.

Ziel der Erfindung ist es, ein Verfahren anzugeben, das sich durch geringe Komplexität hinsichtlich Hardware-Einsatz bzw. Rechnerleistung auszeichnet, sodaß die Durchführung auf einfache und kostengünstige Weise erfolgen kann.

Weiters ist es Ziel der Erfindung, ein Verfahren zu schaffen, mit dem sich bei Übertragungen, die zu einem großen Teil nur in einer der beiden Übertragungsrichtungen vor sich gehen, mit hoher Übertragungsgeschwindigkeit durchführen lassen.

Weitere Aufgabe der Erfindung ist es, eine sehr gute Übertragungsqualität mit relativ geringem technischen Aufwand zu erreichen, wobei eine Änderung der Übertragungskapazität einfach und kostengünstig möglich sein soll.

Erfindungsgemäß wird dies dadurch erreicht, daß die zu sendenden und zu empfangenden Daten durch Zeitmultiplexbetrieb (TDM) getrennt werden, wobei der zugehörige Multiplex-Zeitrahmen in eine vorbestimmbare Anzahl  $N$  von Zeitschlitzen unterteilt wird, und davon eine Anzahl  $K$  von Zeitschlitzen ausschließlich einer Übertragungsrichtung, z.B. Senden, und die restliche Anzahl  $(N-K)$  von Zeitschlitzen ausschließlich der anderen Übertragungsrichtung, z.B. Empfangen, zugeordnet wird.

Da beim erfindungsgemäßen Verfahren entweder nur Sender- oder nur Empfängerfunktionen aktiv sind, wird weniger Prozessorleistung als bei herkömmlichen Verfahren benötigt, da letztere einen sehr hohen internen Datenverkehr zu bewältigen haben. Dadurch gelingt es, eine nach dem erfindungsgemäßen Verfahren durchgeführte Übertragung sehr kostengünstig zu implementieren.

Das erfindungsgemäße Verfahren bietet weiters den Vorteil einer gleichen Übertragungsqualität in beiden Übertragungsrichtungen, da Senden und Empfangen bei TDM mit der gleichen Leitungsdämpfung erfolgt. Dadurch können beide Übertragungsrichtungen mit geringstmöglicher Qualitätsminderung im gleichen Frequenzbereich durchgeführt werden. Ein weiterer Vorteil des erfindungsgemäßen Verfahrens ist die sehr einfache Veränderung der Übertragungskapazität, die durch die entsprechende Wahl der Anzahl der Zeitschlitze für die jeweilige Übertragungsrichtung ermöglicht wird.

Als besonders vorteilhaft bei asymmetrischer Datenübertragung kann es sein, wenn in einer Übertragungsrichtung der Großteil der Daten und in der anderen nur ein kleiner Rest übertragen wird. Dies ist dann gegeben, wenn die Anzahl  $N$  der Zeitschlitze sehr viel größer als die Anzahl  $K$  gewählt wird. Vorzugsweise ist diese Bedingung erfüllt, wenn  $N$  gleich 30 und  $K$  gleich 1 ist.

Da das erfindungsgemäße Verfahren zur Datenübertragung über Telefonleitungen eingesetzt werden kann, kann es z.B. durch die Nummernwahl auf der Leitung zu impulsartigen Störungen kommen, die einen Übertragungsfehler bewirken, der unbedingt korrigiert werden muß. Die Datenübertragung muß aber nicht über Telefonleitungen erfolgen, sie kann im Rahmen der Erfindung über jede dafür geeignete Zweidrahtleitung

geschehen. Genauso können die unterschiedlichsten elektromagnetischen Störungen, auch systemexterne, auf die Datenübertragung ihren Einfluß haben.

Das bekannte ARQ (Automatic Repeat Request)-Verfahren wird zur Fehlerkorrektur üblicherweise so eingesetzt, daß die Datenübertragung auch bei beliebigen Störungen auf der Leitung fehlerfrei bleibt, wobei der Datendurchsatz jedoch stark absinken kann, da ein fehlerhaft übertragenes Datenpaket solange wiederholt wird, bis es fehlerfrei empfangen wird.

In weiterer Ausbildung der Erfindung kann daher vorgesehen sein, daß im Multiplex-Zeitrahmen der Datenübertragung im Zeitmittel eine vorbestimmbare Anzahl von Zeitschlitzen für ARQ (Automatic Repeat Request)-Übertragungswiederholungen vorgesehen sind.

Bei dieser Ausführungsform steht somit ständig Übertragungs-Überkapazität zur Verfügung. Wird ein Datenblock fehlerhaft empfangen, fordert der Empfänger nur so oft eine Wiederholung an, wie es im Rahmen der im Zeitmittel zur Verfügung stehenden Überkapazität möglich ist, sodaß unbeeinflußt durch die Übertragungswiederholungen der nominelle Datendurchsatz konstant gehalten werden kann. Im fehlerfreien Übertragungsfall wird ein höher redundantes Signal übermittelt. Die Dauer der Zeitspanne, über die die Zeitmittelung erfolgt, ist im wesentlichen durch die Speicherkapazität des eingesetzten ARQ-Puffers begrenzt.

Nach einer anderen Variante der Erfindung kann vorgesehen sein, daß bei fehlerhafter Übertragung die Daten, z.B. mittels eines Rechenalgorithmus, modifiziert übertragen werden.

Dadurch kann der bei der Übertragung auftretende Fehler, der durch das Abschneiden eines Teils der Amplitude bei Sende-Übersteuerung hervorgerufen wird, korrigiert werden.

In besonders bevorzugter Weise kann dabei vorgesehen sein, daß die Daten durch logische Inversion modifiziert werden.

Diese Inversionsoperation stellt einen sehr einfach berechenbaren Algorithmus dar, der ohne großen Aufwand realisierbar ist.

Weiters kann vorgesehen sein, daß die Schaltfrequenz einer Störquelle, z.B. ein Netzteil, mit einer der Trägerfrequenzen der diskreten Mehrtonmodulation synchronisiert wird.

Dadurch kann das auf frequenzselektive Störungen empfindliche DMT-Verfahren gegen bekannte Störquellen gesichert werden. Bei Synchronisation der Schaltfrequenz der Störquelle auf eine der Trägerfrequenzen der DMT-Modulation wirkt sich die Störung nur auf diese Trägerfrequenz und deren Vielfache aus, sodaß sie durch einen adaptiven Algorithmus kompensiert werden können.

Bei mehreren nebeneinander geführten Zweidrahtleitungen, auf denen jeweils Daten übertragen werden, ergibt sich üblicherweise ein Übersprechen, welches auf die Übertragung naturgemäß störend wirkt.

Gemäß einer anderen Ausführungsform des erfindungsgemäßen Verfahrens, bei welchem Daten über zwei oder mehr Zweidrahtleitungen, die zumindest teilweise in

Übersprechabstand geführt sind, übertragen werden, kann vorgesehen sein, daß der Zeitmultiplex-Betrieb (TDM) auf allen Zweidrahtleitungen synchron durchgeführt wird, sodaß auf allen Zweidrahtleitungen gleichzeitig entweder gesendet oder empfangen wird. Dadurch wird immer zur gleichen Zeit entweder gesendet oder empfangen, sodaß eine störende Beeinflussung der einzelnen Empfänger durch nicht direkt verbundene Sender vermieden werden kann.

Im folgenden wird die Erfindung anhand eines in den Zeichnungen dargestellten Ausführungsbeispiels näher erläutert.

Es zeigt dabei:

Fig.1 ein Blockschaltbild zur Durchführung einer Ausführungsform des erfindungsgemäßen Verfahrens und

Fig.2 eine schematische Darstellung eines erfindungsgemäßen Zeitrahmens.

Eine bidirektionale Datenübertragung von digitalen Daten gemäß dem in Fig.1 dargestellten Blockschaltbild wird durchgeführt, indem beim Senden die aus einer Datenquelle 1,4 kommenden digitalen Daten im Sendeteil 50 zu einem analogen Sendesignal umgewandelt und über einen Leitungsübertrager 13 einer Zweidrahtleitung 100 an einen am Ende dieser Leitung 100 gelegenen Teilnehmer übertragen werden. Demgegenüber wird ein auf der Zweidrahtleitung 100 ankommendes Signal über den Leitungsübertrager 13 als Empfangssignal an den Eingang eines Empfangsteils 51 geführt und dort in digitale Daten umgewandelt. Da beim erfindungsgemäßen Verfahren nie gleichzeitig gesendet und empfangen wird, kann an Stelle einer sonst üblichen Gabelschaltung der Leitungsübertrager 13 verwendet werden, wodurch die oft problematische Anpassung der Gabelschaltung an die Leitungsimpedanz von vornherein wegfällt. Ein durch eine Gabelschaltung bedingtes störendes Übersprechen, durch welches Signalreste vom Sender zum Empfänger derselben Teilnehmerseite gelangen, scheidet somit als Störquelle für dieses Verfahren aus.

In dem in Fig.1 gezeigten Ausführungsbeispiel ist der Sende- und Empfangsteil 50, 51 sowohl einer zentralen Datenstelle C (CENTRAL) als auch einer peripheren Datenstelle R (REMOTE) in einem einzigen Blockschaltbild dargestellt, welches so zu verstehen ist, daß die zentrale Datenstelle C über den Übertrager 13, die Zweidrahtleitung 100 und einen weiteren Übertrager 13 mit der Datenstelle R verbunden ist. Jene Funktionseinheiten, die nur zur Datenstelle C bzw. R zugehörig sind, sind mit "ATU-C only" bzw. "ATU-R only" gekennzeichnet.

Ohne Beschränkung der allgemeinen Anwendbarkeit des erfindungsgemäßen Verfahrens sei als Ausführungsbeispiel einer asymmetrischen Datenübertragung ein Heimvideosystem beschrieben, bei welchem in der zentralen Datenstelle C die Videoinformation verschiedener Videos in einem Großrechner als Daten in komprimierter Form gespeichert und über eine periphere Datenstelle R abrufbar ist. Über einen bidirektionalen Steuerkanal wird die Steuerinformation zwischen den Datenstellen C und R ausgetauscht, wobei eine Datenrate von 64 kbit/s festgelegt ist. Diese Steuerinformation kann sich auf verschiedene vom Teilnehmer auszugebende Befehle, wie etwa PLAY, REWIND o.ä., wie sie von einem

Videorecorder bekannt sind sowie interne Steuerkommandos beziehen und ist in ihrer Menge vergleichsweise gering gegenüber der von der zentralen Datenstelle C ausgesendeten Breitbandinformation, die im wesentlichen die Videoinformation beinhaltet, die mit einer Datenübertragungsrate von 2,048 Mbit/s nur in einer Richtung von C zu R gesendet wird.

Die genannten Datenraten können jedoch für das erfindungsgemäße Verfahren aber auch gänzlich anders, z.B. viel höher gewählt werden, wobei für die nur in eine Richtung zu übermittelnde Breitbandinformation auch eine Datenrate von etwa 50 Mbit/s bis 150 Mbit/s zur Verfügung gestellt werden kann. Die übertragene Information kann dabei jede Art von Sprach-, Bild- oder Dateninformation darstellen. Ebenso ist eine andere Rate für den bidirektionalen Steuerkanal ausführbar, der aber nicht nur Steuerfunktionen sondern alle möglichen Datenübertragungsfunktionen erfüllen kann.

Am eingangsseitigen Teil des Sendeteils 50 sind für die Datenstelle C zwei verschiedene Dateneingänge und für die Datenstelle R nur ein Dateneingang ausgebildet. An den ersten Eingang, der für C und R gleich ist, gelangt der Datenstrom aus der Datenquelle 1, die z.B. im wesentlichen Steuerbefehle aussendet, die über einen nachfolgenden Verwürfler 2 in einen diesem nachfolgenden Sendepuffer 3 gelangen, wobei die aus der Datenquelle 1 kommenden Daten im Verwürfler 2 nach einem vorbestimmbaren Algorithmus gewandelt werden. Dadurch wird ein länger andauernder, konstanter logischer Zustand verhindert und eine ausgeglichene statistische Verteilung der binären Zustände erreicht. Anschließend daran erfolgt im Sendepuffer 3 eine Zwischenspeicherung der verwürfelten Signale. In der Datenstelle R sind die aus dem Sendepuffer 3 austretenden Daten über eine Vorrichtung MUX mit anderen Daten, die im ARQ-Puffer 24 erzeugt werden und Wiederholanweisungen enthalten, gemultiplext.

Am zweiten Eingang des Sendeteils 50, der nur für die Datenstelle C ausgeführt ist, kommt der Datenstrom aus der Datenquelle 4, die die Breitbandinformation generiert, über einen nachfolgenden Verwürfler 5 und über einen ARQ (Automatic Request)-Puffer 6, der einen CRC-Generator enthält, über den eine Fehlerkorrekturkodierung erfolgt, an den zweiten Eingang des Sendeteils 50. Die im Verwürfler 5 umgewandelten Daten werden im ARQ-Puffer 6 zwischengespeichert und bei fehlerhafter Übertragung wiederholt. Eine besondere, erfindungsgemäße ARQ-Übertragungstechnik wird weiter unten noch beschrieben.

Die über die Eingänge des Sendeteils 50 seriell eintreffenden Daten werden im Kodierer 7 zum Herabsetzen der Datenrate in vorbestimmbarer Länge zusammengefaßt und anhand einer Kodiertabelle einem entsprechenden Symbol zur weiteren Verarbeitung zugeordnet. Weiters wird dieses kodierte Signal in dem nachfolgenden DMT (Discrete Multi Tone)-Modulator 8 nach diesem bekannten Verfahren moduliert und über ein Hochpaß-Filter 9 geleitet, welches zur Vermeidung von Störeinflüssen im wesentlichen das Sprachfrequenzband unterdrückt. Das digitale Ausgangssignal dieses Hochpaß-Filters 9 wird über einen Digital-Analog-Wandler 10 in ein analoges Signal gewandelt, welches über ein Bandpaß-Filter 11 und anschließend über einen Verstärker 12 zum Wandler 13 gelangt. Das Bandpaß-Filter 11 erfüllt einerseits nochmals die Funktion des Hochpasses 11 und

andererseits schneidet es die durch den Analog-Digital-Wandler 10 hervorgerufenen hochfrequenten Spannungsspitzen ab. Die Frequenz der Analog-Digital-Wandlung ist zur Erfüllung des Abtasttheorems so gewählt, daß für die höchsten vorkommenden Frequenzen mindestens zweimal eine Abtastung durch den Analog-Digital-Wandler 10 erfolgt.

Der Sendeteil 50 und der Empfangsteil 51 sind durch eine TDM (Time Division Multiplex)-Einheit 30 gesteuert, sodaß erfindungsgemäß die zu sendenden und die zu empfangenden Daten durch Zeitmultiplexbetrieb getrennt werden, wobei der zugehörige Multiplex-Zeitrahmen in eine vorbestimmbare Anzahl N von Zeitschlitzen unterteilt wird, und davon eine Anzahl K von Zeitschlitzen des Zeitrahmens ausschließlich einer Übertragungsrichtung, z.B. Senden, und die restliche Anzahl N-K von Zeitschlitzen ausschließlich der anderen Übertragungsrichtung, z.B. Empfangen, zugeordnet wird. Dazu steuert die TDM-Einheit den Sendeteil 50 und den Empfangsteil 51, indem sie zur gegebenen Zeit diese aktiviert. Der Sendeteil 50 und der Empfangsteil 51 sind dabei nie gleichzeitig in Betrieb, wodurch die für die Steuerung benötigte Prozessorleistung entsprechend niedrig ausgelegt werden kann. Da dadurch auch eine Beeinflussung des eigenen Senders auf den Empfänger ausgeschlossen ist, ist für den Analog-Digital-Wandler 16 des Empfängerteils nur eine geringe Auflösung erforderlich. Dieser Vorteil wirkt sich infolge der direkten Proportionalität von Auflösung und Preis bei Analog-Digital-Wandlern sehr kostengünstig aus.

Das erfindungsgemäße Verfahren hat den Vorteil eines relativ geringen Bandbreitenbedarfes und einer sehr geringen Komplexität, die sich bei der Hardware bzw. bei der benötigten Rechnerleistung zeigt. Bei herkömmlichen Verfahren zur Trennung von Senden und Empfangen geht ein beträchtlicher Teil der Rechnerleistung für interne Kommunikation verloren, während beim erfindungsgemäßen Verfahren diese Rechner-Hilfskapazität sehr gering gehalten werden kann.

Das erfindungsgemäße Verfahren hat dort seine Grenze, wo sich der Anteil des Sendens und Empfangens der 50%-Prozentgrenze nähert, da dann andere Verfahren etwa wie Echo-Cancelling o.ä. mit gleichgroßem oder kleinerem Aufwand durchgeführt werden können.

In Fig.2 ist der in Zeitschlitze unterteilte Zeitrahmen, wie er im erfindungsgemäßen Verfahren zur Anwendung gelangt, dargestellt. Die beiden Übertragungsrichtungen sind durch die Ausdrücke "upstream" und "downstream" gekennzeichnet. Der ganze Zeitrahmen ist in diesem Beispiel 20,625 ms lang und in verschiedene Schlitze zu 625  $\mu$ s aufgeteilt, wobei die Mehrzahl der Daten in downstream-Richtung übertragen wird. Diese Aufteilung ist besonders dann von Vorteil, wenn in einer Übertragungsrichtung ein bidirektionaler Kanal mit geringer und ein unidirektionaler Kanal mit hoher Datenrate benötigt wird. In dem dargestellten Ausführungsbeispiel werden über den bidirektionalen Kanal durch die mit CONTROL bezeichneten Zeitschlitze in downstream- und upstream-Richtung Steuerbefehle und über den unidirektionalen Kanal durch die mit VIDEO bezeichneten 30 downstream-Zeitschlitze mit im Zeitmittel einem Hilfsschlitze Videoinformation übertragen. Diese Art der Übertragung kann für beliebige Informationen erfolgen.

Die Verteilung der Sende- bzw. Empfangskapazitäten ist den jeweiligen Verhältnissen durch Wahl der Anzahl der upstream bzw. downstream-Zeitschlitz anpaßbar. Bei sich ändernden Auslastungen kann dieses Verhältnis automatisch entsprechend dem aktuellen Bedarf abgestimmt werden. Die festgelegten Sende- und Empfangszeiten haben gegenüber einer Frequenzmultiplex-Übertragung den Vorteil, daß nicht gleichzeitig empfangene und zu sendende Daten verarbeitet werden müssen, wodurch die Rechnerleistung bzw. der Hardware-Aufwand entsprechend niedrig ausgelegt werden kann. In jedem DMT-Schlitz wird eine codierte und DMT-modulierte Dateneinheit übertragen.

Für ARQ-Übertragungswiederholungen wird gemäß einer erfindungsgemäßen Ausführungsform im Multiplex-Zeitrahmen der Datenübertragung im Zeitmittel eine vorbestimmbare Anzahl von Zeitschlitz für ARQ-Übertragungswiederholungen vorgesehen sind. Dazu werden beim Senden der Daten diese ständig in den ARQ-Sendepuffer 6 eingeschrieben und von diesem wieder an den Kodierer 7 weitergegeben. Dabei werden die vom Puffer 6 abgehenden Daten schneller übertragen als dieser gefüllt wird. In der dabei entstehenden Lücke wird erneut jeweils der letzte Datenblock eingetragen, dieser wird jedoch empfängerseitig als wiederholter Block erkannt und automatisch beseitigt. Somit wird im fehlerfreien Übertragungsfall ständig mit Überkapazität gesendet, ohne daß der übertragene Informationsgehalt größer ist.

Sobald ein Übertragungsfehler auftritt, erkennt der Empfänger in der peripheren Datenstelle R den Fehler mittels seiner CRC- Fehlererkennung in der ARQ-Einheit 24 und gibt darauf den Befehl über den Multiplexer des Sendepuffers 3 zur Datenwiederholung weiter, der dann als Steuerinformation über den bidirektionalen Kanal gesendet wird. In der zentralen Datenstelle C wird diese Information nach Durchlaufen des Empfängerteils 51 im Empfängerpuffer 27 gedemultiplext und ein Steuerbefehl an den ARQ-Puffer 6 gegeben, die fehlerhafte Übertragung zu wiederholen.

Dafür steht in diesem Ausführungsbeispiel im Zeitmittel nur ein Hilfsschlitz zur Verfügung, was einer Überkapazität von 3,33% entspricht. Dauer und Anzahl der Hilfsschlitz sind in diesem Zusammenhang keiner Einschränkung unterworfen und können innerhalb des technisch Realisierbaren beliebig den jeweiligen Verhältnissen angepaßt werden.

Nach einer Fehlübertragung wird nun im darauffolgenden Zeitrahmen, die Wiederholungsübertragung durchgeführt, die sich über mehrere nacheinanderfolgende Zeitschlitz erstrecken kann. Gemittelt über die Zeit sollte in diesem Beispiel nur ein Zeitschlitz pro Rahmen für die Wiederholungen benutzt werden.

Die Zeitspanne, über die dabei das Zeitmittel berechnet wird, ist durch die Größe des ARQ-Pufferspeichers festgelegt. Sobald dieser mit Information vollgeschrieben ist, können keine weiteren Wiederholungen durchgeführt werden und der fehlerhafte Datenblock muß als transparent ausgegeben werden.

Gegenüber einem herkömmlichen ARQ-Verfahren ist die für die Datenwiederholungen festgelegte Zeitspanne im Zeitmittel fixiert. Dadurch kann es nicht passieren, daß aufgrund einer länger andauernden Störung die Übertragung solange wiederholt wird bis sie fehlerfrei

ist und damit die Übertragungszeit sich stark erhöht. Durch das bekannte ARQ-Verfahren wird die Datenübertragung auch bei beliebigen Störungen solange wiederholt, bis sie fehlerfrei empfangen wird, wodurch der Datendurchsatz aber sehr stark sinkt. Hingegen wird durch die feste Überkapazität, die zwischen 2 und 10%, vorzugsweise aber zwischen 3 und 5% liegt, im erfindungsgemäßen Verfahren die Übertragung nur so oft wiederholt, wie es im Rahmen der Überkapazität möglich ist, um den nominellen Datendurchsatz aufrecht zu erhalten. Kann bei mehreren aufeinanderfolgenden falschen Datenblöcken einer nicht mehr wiederholt und richtig empfangen werden, wird er transparent ausgegeben.

Bei einem durch die diskrete Mehrtonmodulation (DMT) modulierten Signal ist das Verhältnis von Spitzenwert zu Mittelwert sehr groß, sodaß ein Abkappen ("Clipping") der Signalspitze eine häufige Fehlerquelle darstellt. Um diesen Fehler auf einfache Weise zu korrigieren, kann nach einer fehlerhaften Datenübertragung die digitale Bitfolge beim Wiederholvorgang im Sender z.B. durch einen Rechenalgorithmus, modifiziert werden und dann erneut übertragen werden. Im Empfänger wird der verwendete Rechenalgorithmus entsprechend in Umkehrung angewendet und die Daten wiedergewonnen. Dadurch kann dieser Übertragungsfehler sehr effektiv ausgeschaltet werden. Im besonderen ist es schaltungs- oder rechentechnisch auf einfache Weise durchführbar, die fehlerhaften Daten in invertierter Form zu übertragen

Eine weitere Störquelle beim DMT-Verfahren ergibt sich aus der Schaltfrequenz der eingesetzten Spannungsversorgung, z.B. des Netzteils, da diese Schaltfrequenz im Übertragungsbereich liegt und somit als frequenzselektive Störung ihre Auswirkung zeigt. Hinzu kommt die Abhängigkeit dieser Störungen von anderen Einflußgrößen, etwa die gerade am Netzteil vorliegende Last. Diese Art von Störungen können verringert werden, indem die Schaltfrequenz des Netzteils auf eine der Trägerfrequenzen der DMT-Modulation synchronisiert wird. Damit wirkt sich diese Störung nur auf diese Trägerfrequenz und ihre Vielfache aus, sodaß sie sehr leicht durch einen adaptiven Algorithmus kompensiert werden können.

In Fig.1 ist weiters der dem Sendeteil 50 entsprechende Empfangsteil 51 dargestellt. Die über die Zweidrahtleitung 100 und den Übertrager 13 von der anderen Teilnehmerseite einlangenden Signale werden über einen Bandpaß 14 und über eine AGC (Automatic Gain Control)-Einheit, die unabhängig von den momentanen Signalverhältnissen auf der Leitung ein annähernd amplitudenkonstantes Signal erzeugt, an den Eingang eines zum Empfangsteil 51 gehörigen Analog-Digital-Wandlers 16 geführt, dessen Ausgang mit einem Hochpaß-Filter 17 verbunden ist. Das am Eingang des Hochpasses 17 anliegende Signal wird über einen AGC-Regelkreis 18 als Stellgröße zur AGC-Einheit 15 rückgeführt.

Nach dem Hochpaß 17 erfolgt die Demodulation des Signals, aus welchem nur in der peripheren Datenstelle R der mitübertragene Pilotton einer Pilot-AGC-Einheit 20 zugeführt wird, woraus in der Taktgewinnungseinheit 21 ein Referenzsignal für die Takterzeugungseinheit 31 der peripheren Datenstelle R gewonnen wird. Diese Takterzeugungseinheit 31 generiert für die TDM-Einheit 30 und für den Systemtakt die



Zeitbasis. Die Datenstelle C benötigt keine Taktgewinnungseinheit, da hier eine unabhängige Zeitbasis vorgesehen ist.

Die durch die Übertragungsstrecke bewirkten linearen Verzerrungen werden in einem an den DMT-Demodulator 19 anschließenden Entzerrer 22 mit update-Funktion beseitigt. Daran anschließend findet in einem Dekodierer 23 das Umschlüsseln entsprechend einer Dekodiertabelle statt, woraufhin am Ausgang des Dekodierers 23 wieder ein serieller Bitstrom vorliegt, der über zwei Ausgänge geführt wird. Der für Datenstelle C und R gleich ausgeführte erste Ausgang besteht aus einem Empfangs-Puffer 27 für Steuerinformation, einem nachfolgenden Entwürfler 28, in welchem die Daten in ihrer richtigen Reihenfolge wiederhergestellt werden und der Datensinke 29, die die gesendeten Steuerdaten empfängt. Der zweite Ausgang des Empfangsteils 51, welcher nur für die Datenstelle R vorgesehen ist, ist mit einem ARQ-Puffer 24 verbunden, der die übertragene Breitbandinformation aus der Datenstelle C zwischenspeichert, verifiziert und bei Bedarf über eine im ARQ-Puffer 24 integrierte Steuereinheit den Befehl zum nochmaligen Senden der fehlerhaft übertragenen Daten an den Multiplex-Eingang des Sendepuffers 3 gibt, der zur Datenstelle C rückübertragen wird. Am Ausgang des ARQ-Puffers 24 ist ein Entwürfler 25 und daran anschließend eine Datensinke 26 zur Übernahme der Breitbandinformation angeschlossen.

Werden Daten über zwei oder mehr Zweidrahtleitungen, die zumindest teilweise in Übersprechabstand geführt sind, übertragen, kann es geschehen, daß durch die gegenseitige induktive Beeinflussung der Zweidrahtleitungen es zum Übersprechen kommt. Besonders in einer zentralen Datenanlage, in der viele abgehende Zweidrahtleitungen nebeneinander geführt werden, kann es zu dieser unerwünschten Störung kommen.

Bei einer Ausführungsform des erfindungsgemäßen Verfahrens wird diese Art der Störung vermieden, indem der Zeitmultiplex-Betrieb auf allen Zweidrahtleitungen synchron durchgeführt wird. Dies bedeutet, daß gleichzeitig über alle Zweidrahtleitungen entweder gesendet oder empfangen wird, sodaß keine Beeinflussung mehr möglich ist.

### Patentansprüche

1. Verfahren zur bidirektionalen Datenübertragung über eine Zweidrahtleitung, wobei digitale Daten zum Senden oder Empfangen, z.B. mittels diskreter Mehrtonmodulation (DMT), moduliert bzw. demoduliert und die zu sendenden und zu empfangenden Daten, z.B. durch Frequenzmultiplexbetrieb (FDM) oder Echoauslöschung (EC), getrennt werden, **dadurch gekennzeichnet**, daß die zu sendenden und zu empfangenden Daten durch Zeitmultiplexbetrieb (TDM) getrennt werden, wobei der zugehörige Multiplex-Zeitrahmen in eine vorbestimmbare Anzahl N von Zeitschlitzen unterteilt wird, und davon eine Anzahl K von Zeitschlitzen ausschließlich einer Übertragungsrichtung, z.B. Senden, und die restliche Anzahl (N-K) von Zeitschlitzen ausschließlich der anderen Übertragungsrichtung, z.B. Empfangen, zugeordnet wird.
2. Verfahren nach Anspruch 1, **dadurch gekennzeichnet**, daß N gleich 30 und K gleich 1 ist.
3. Verfahren nach Anspruch 1 oder 2, **dadurch gekennzeichnet**, daß im Multiplex-Zeitrahmen der Datenübertragung im Zeitmittel eine vorbestimmbare Anzahl von Zeitschlitzen für ARQ (Automatic Repeat Request)-Übertragungswiederholungen vorgesehen sind.
4. Verfahren nach Anspruch 1, 2 oder 3, **dadurch gekennzeichnet**, daß bei fehlerhafter Übertragung die Daten, z.B. mittels eines Rechenalgorithmus, modifiziert wiederholt übertragen werden.
5. Verfahren nach Anspruch 4, **dadurch gekennzeichnet**, daß die Daten durch logische Inversion modifiziert werden.
6. Verfahren nach Anspruch 1 bis 5, **dadurch gekennzeichnet**, daß die Schaltfrequenz einer Störquelle, z.B. ein Netzteil, mit einer der Trägerfrequenzen der diskreten Mehrtonmodulation synchronisiert wird.
7. Verfahren nach Anspruch 1 bis 6, wobei Daten über zwei oder mehr Zweidrahtleitungen, die zumindest teilweise in Übersprechabstand geführt sind, übertragen werden, **dadurch gekennzeichnet**, daß der Zeitmultiplex-Betrieb (TDM) auf allen Zweidrahtleitungen synchron durchgeführt wird, sodaß auf allen Zweidrahtleitungen gleichzeitig entweder gesendet oder empfangen wird.

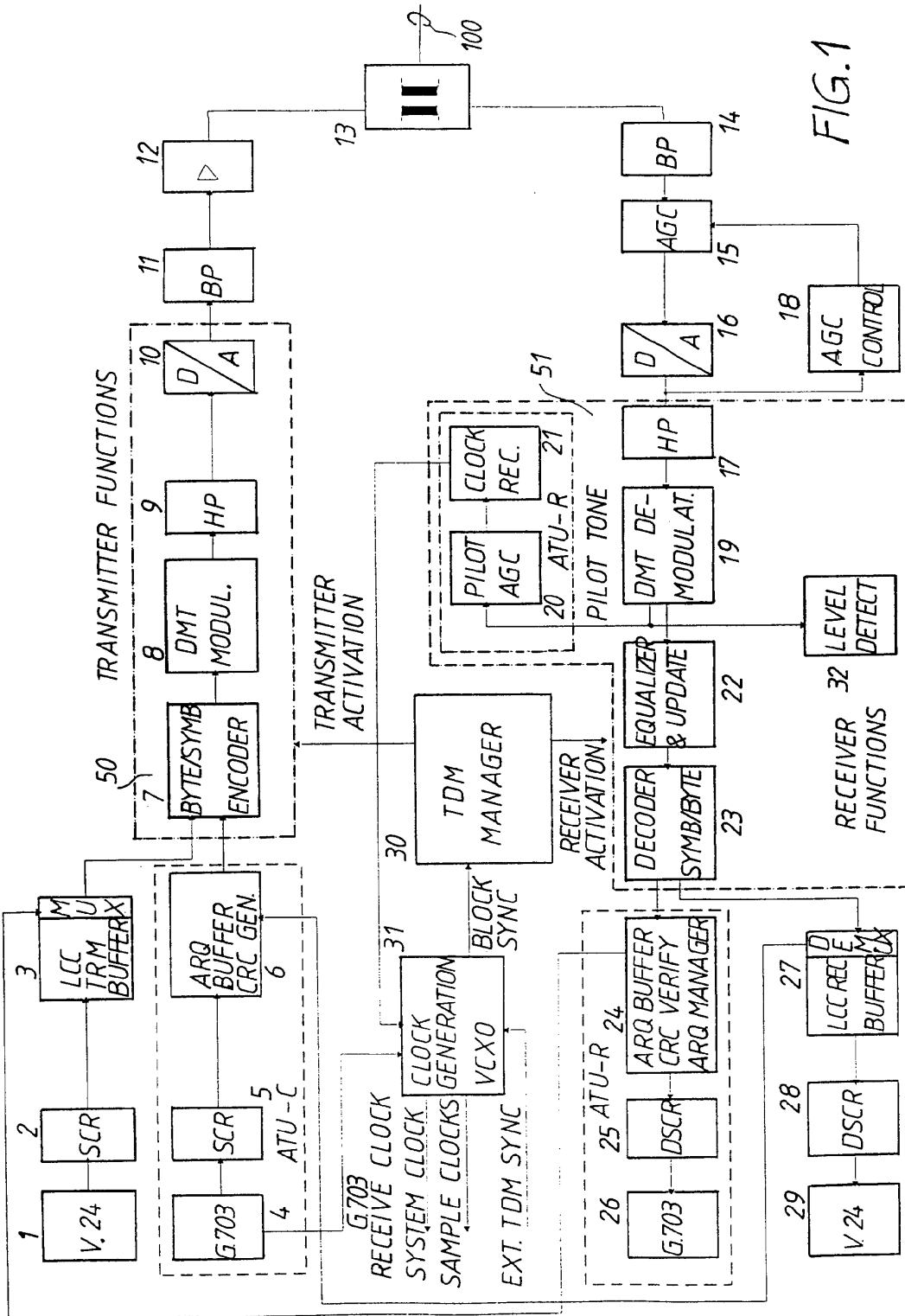

FIG. 1

ERSATZBLATT (REGEL 26)

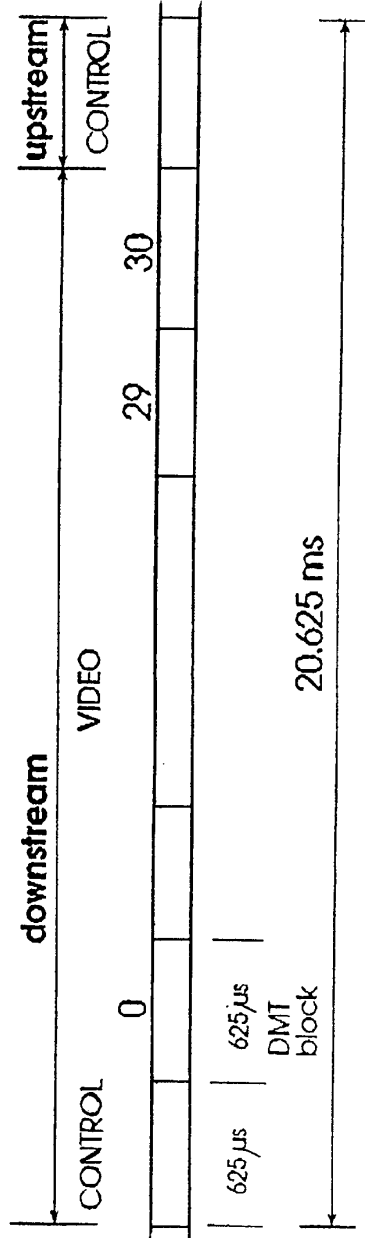

FIG. 2

# INTERNATIONAL SEARCH REPORT

International Application No  
PCT/AT 96/00112

<b>A. CLASSIFICATION OF SUBJECT MATTER</b> IPC 6 H04L5/14		
According to International Patent Classification (IPC) or to both national classification and IPC		
<b>B. FIELDS SEARCHED</b>		
Minimum documentation searched (classification system followed by classification symbols) IPC 6 H04L H04N		
Documentation searched other than minimum documentation to the extent that such documents are included in the fields searched		
Electronic data base consulted during the international search (name of data base and, where practical, search terms used)		
<b>C. DOCUMENTS CONSIDERED TO BE RELEVANT</b>		
Category *	Citation of document, with indication, where appropriate, of the relevant passages	Relevant to claim No.
X	US,A,4 796 255 (WESTBROOK ET AL.) 3 January 1989 see column 1, line 17 - line 59 see column 2, line 45 - line 68	1,2
A	see figures 1,2 ---	3-7
X	SINGAPORE ICCS '94. CONFERENCE PROCEEDINGS. (CAT. NO.94TH0691-6), PROCEEDINGS OF ICCS '94, SINGAPORE, 14-18 NOV. 1994, ISBN 0-7803-2046-8, 1994, NEW YORK, NY, USA, IEEE, USA, pages 571-575 vol.2, XP002016282 YONG HOON KIM ET AL.: "Dynamic frame control for TDD based wireless LAN" see page 572, paragraph 2.1 see figures 1,2 --- -/--	1,2
<input checked="" type="checkbox"/> Further documents are listed in the continuation of box C.		
<input checked="" type="checkbox"/> Patent family members are listed in annex.		
* Special categories of cited documents :		
"A" document defining the general state of the art which is not considered to be of particular relevance "E" earlier document but published on or after the international filing date "L" document which may throw doubts on priority claim(s) or which is cited to establish the publication date of another citation or other special reason (as specified) "O" document referring to an oral disclosure, use, exhibition or other means "P" document published prior to the international filing date but later than the priority date claimed "T" later document published after the international filing date or priority date and not in conflict with the application but cited to understand the principle or theory underlying the invention "X" document of particular relevance; the claimed invention cannot be considered novel or cannot be considered to involve an inventive step when the document is taken alone "Y" document of particular relevance; the claimed invention cannot be considered to involve an inventive step when the document is combined with one or more other such documents, such combination being obvious to a person skilled in the art. "&" document member of the same patent family		
Date of the actual completion of the international search	Date of mailing of the international search report	
18 October 1996	12. 11. 96	
Name and mailing address of the ISA European Patent Office, P.B. 5818 Patentlaan 2 NL - 2280 HV Rijswijk Tel. (+ 31-70) 340-2040, Tx. 31 651 epo nl, Fax: (+ 31-70) 340-3016		Authorized officer  Ghigliotti, L

Form PCT/ISA/210 (second sheet) (July 1992)

INTERNATIONAL SEARCH REPORT

International Application No  
PCT/AT 96/00112

C.(Continuation) DOCUMENTS CONSIDERED TO BE RELEVANT		
Category *	Citation of document, with indication, where appropriate, of the relevant passages	Relevant to claim No.
X	IEEE TRANSACTIONS ON VEHICULAR TECHNOLOGY, NOV. 1994, USA, vol. 43, no. 4, ISSN 0018-9545, pages 934-945, XP002016283 WAI-CHOONG WONG ET AL.: "Shared time division duplexing: an approach to low-delay high-quality wireless digital speech communications" see paragraph II, pages 935-936 see figure 1 ---	1,2
X	GB,A,2 145 609 (GEN. ELECTRIC CO. PLC) 27 March 1985 see abstract see page 2, line 41 - line 54 see figure 2 ---	1,2
X	US,A,4 841 521 (AMADA ET AL.) 20 June 1989 see abstract see figures 1,3 -----	1,2

1

# INTERNATIONAL SEARCH REPORT

Information on patent family members

Intern. Application No <b>PCT/AT 96/00112</b>
--

Patent document cited in search report	Publication date	Patent family member(s)	Publication date
US-A-4796255	03-01-89	NONE	
GB-A-2145609	27-03-85	US-A- 4644525	17-02-87
US-A-4841521	20-06-89	CA-A- 1274928 DE-A- 3717854 JP-A- 63099642	02-10-90 10-12-87 30-04-88

INTERNATIONALER RECHERCHENBERICHT

Internationale Aktenzeichen

PCT/AT 96/00112

A. KLASSIFIZIERUNG DES ANMELDUNGSGEGENSTANDES IPK 6 H04L5/14		
Nach der Internationalen Patentklassifikation (IPK) oder nach der nationalen Klassifikation und der IPK		
B. RECHERCHIERTE GEBIETE		
Recherchierter Mindestprüfstoff (Klassifikationssystem und Klassifikationssymbole ) IPK 6 H04L H04N		
Recherchierte aber nicht zum Mindestprüfstoff gehörende Veröffentlichungen, soweit diese unter die recherchierten Gebiete fallen		
Während der internationalen Recherche konsultierte elektronische Datenbank (Name der Datenbank und evtl. verwendete Suchbegriffe)		
C. ALS WESENTLICH ANGESEHENE UNTERLAGEN		
Kategorie*	Bezeichnung der Veröffentlichung, soweit erforderlich unter Angabe der in Betracht kommenden Teile	Betr. Anspruch Nr.
X	US,A,4 796 255 (WESTBROOK ET AL.) 3. Januar 1989 siehe Spalte 1, Zeile 17 - Zeile 59 siehe Spalte 2, Zeile 45 - Zeile 68	1,2
A	siehe Abbildungen 1,2	3-7
X	SINGAPORE ICCS '94. CONFERENCE PROCEEDINGS. (CAT. NO.94TH0691-6), PROCEEDINGS OF ICCS '94, SINGAPORE, 14-18 NOV. 1994, ISBN 0-7803-2046-8, 1994, NEW YORK, NY, USA, IEEE, USA, Seiten 571-575 vol.2, XP002016282 YONG HOON KIM ET AL.: "Dynamic frame control for TDD based wireless LAN" siehe Seite 572, Absatz 2.1 siehe Abbildungen 1,2	1,2
	-/--	
<input checked="" type="checkbox"/> Weitere Veröffentlichungen sind der Fortsetzung von Feld C zu entnehmen <input checked="" type="checkbox"/> Siehe Anhang Patentfamilie		
* Besondere Kategorien von angegebenen Veröffentlichungen : *A* Veröffentlichung, die den allgemeinen Stand der Technik definiert, aber nicht als besonders bedeutsam anzusehen ist *E* älteres Dokument, das jedoch erst am oder nach dem internationalen Anmeldedatum veröffentlicht worden ist *L* Veröffentlichung, die geeignet ist, einen Prioritätsanspruch zweifelhaft erscheinen zu lassen, oder durch die das Veröffentlichungsdatum einer anderen im Recherchenbericht genannten Veröffentlichung belegt werden soll oder die aus einem anderen besonderen Grund angegeben ist (wie ausgeführt) *O* Veröffentlichung, die sich auf eine mündliche Offenbarung, eine Benutzung, eine Ausstellung oder andere Maßnahmen bezieht *P* Veröffentlichung, die vor dem internationalen Anmeldedatum, aber nach dem beanspruchten Prioritätsdatum veröffentlicht worden ist *T* Spätere Veröffentlichung, die nach dem internationalen Anmeldedatum oder dem Prioritätsdatum veröffentlicht worden ist und mit der Anmeldung nicht kollidiert, sondern nur zum Verständnis des der Erfindung zugrundeliegenden Prinzips oder der ihr zugrundeliegenden Theorie angegeben ist *X* Veröffentlichung von besonderer Bedeutung; die beanspruchte Erfindung kann allein aufgrund dieser Veröffentlichung nicht als neu oder auf erfinderscher Tätigkeit beruhend betrachtet werden *Y* Veröffentlichung von besonderer Bedeutung; die beanspruchte Erfindung kann nicht als auf erfinderscher Tätigkeit beruhend betrachtet werden, wenn die Veröffentlichung mit einer oder mehreren anderen Veröffentlichungen dieser Kategorie in Verbindung gebracht wird und diese Verbindung für einen Fachmann naheliegend ist *&* Veröffentlichung, die Mitglied derselben Patentfamilie ist		
Datum des Abschlusses der internationalen Recherche	Absenddatum des internationalen Recherchenberichts	
18. Oktober 1996	12. 11. 96	
Name und Postanschrift der Internationale Recherchenbehörde Europäisches Patentamt, P.B. 5818 Patentlaan 2 NL - 2280 HV Rijswijk Tel. (+31-70) 340-2040, Tx. 31 651 epo nl, Fax: (+31-70) 340-3016	Bevollmächtigter Bediensteter  Ghigliotti, L	

Formblatt PCT/ISA/210 (Blatt 2) (Juli 1992)



INTERNATIONALER RECHERCHENBERICHT

Internationales Aktenzeichen  
PCT/AT 96/00112

C.(Fortsetzung) ALS WESENTLICH ANGESEHENE UNTERLAGEN		
Kategorie	Bezeichnung der Veröffentlichung, soweit erforderlich unter Angabe der in Betracht kommenden Teile	Betr. Anspruch Nr.
X	IEEE TRANSACTIONS ON VEHICULAR TECHNOLOGY, NOV. 1994, USA, Bd. 43, Nr. 4, ISSN 0018-9545, Seiten 934-945, XP002016283 WAI-CHOONG WONG ET AL.: "Shared time division duplexing: an approach to low-delay high-quality wireless digital speech communications" siehe Absatz II, Seiten 935-936 siehe Abbildung 1 ---	1,2
X	GB,A,2 145 609 (GEN. ELECTRIC CO. PLC) 27.März 1985 siehe Zusammenfassung siehe Seite 2, Zeile 41 - Zeile 54 siehe Abbildung 2 ---	1,2
X	US,A,4 841 521 (AMADA ET AL.) 20.Juni 1989 siehe Zusammenfassung siehe Abbildungen 1,3 -----	1,2

1

# INTERNATIONALER RECHERCHENBERICHT

Angaben zu Veröffentlichungen, die zur selben Patentfamilie gehören

Internationales Aktenzeichen  
PCT/AT 96/00112

Im Recherchenbericht angeführtes Patentdokument	Datum der Veröffentlichung	Mitglied(er) der Patentfamilie	Datum der Veröffentlichung
US-A-4796255	03-01-89	KEINE	
GB-A-2145609	27-03-85	US-A- 4644525	17-02-87
US-A-4841521	20-06-89	CA-A- 1274928 DE-A- 3717854 JP-A- 63099642	02-10-90 10-12-87 30-04-88

Formblatt PCT/ISA/210 (Anhang Patentfamilie)(Juli 1992)



INTERNATIONAL APPLICATION PUBLISHED UNDER THE PATENT COOPERATION TREATY (PCT)

<p><b>(51) International Patent Classification</b> <sup>6</sup> : <b>H04M</b></p>	<p><b>A2</b></p>	<p><b>(11) International Publication Number:</b> <b>WO 99/20027</b></p> <p><b>(43) International Publication Date:</b> 22 April 1999 (22.04.99)</p>
<p><b>(21) International Application Number:</b> PCT/US98/21442</p> <p><b>(22) International Filing Date:</b> 9 October 1998 (09.10.98)</p> <p><b>(30) Priority Data:</b> 60/061,689 10 October 1997 (10.10.97) US</p> <p><b>(71) Applicant (for all designated States except US):</b> AWARE, INC. [US/US]; 40 Middlesex Turnpike, Bedford, MA 01730 (US).</p> <p><b>(72) Inventors; and</b></p> <p><b>(75) Inventors/Applicants (for US only):</b> GROSS, Richard, W. [US/US]; 21 Millett Street, Arlington, MA 02174 (US). GRESZCZUK, John, A. [US/US]; 18 Lowell Drive, Stow, MA 01775 (US). KRINSKY, David, M. [US/US]; 4 Ayer Road, Acton, MA 01720 (US). TZANNES, Marcos [US/US]; 665 Lowell Street, Unit #53, Lexington, MA 02173 (US). TZANNES, Michael, A. [US/US]; 17 Carley Road, Lexington, MA 02173 (US).</p> <p><b>(74) Agents:</b> O'DONNELL, Martin, J. et al.; Cesari and McKenna, LLP, 30 Rowes Wharf, Boston, MA 02110 (US).</p>		<p><b>(81) Designated States:</b> AL, AU, BA, BB, BG, BR, CA, CN, CU, CZ, EE, GE, HU, ID, IL, IS, JP, KP, KR, LC, LK, LR, LT, LV, MG, MK, MN, MX, NO, NZ, PL, RO, SG, SI, SK, SL, TR, TT, UA, US, UZ, VN, YU, ARIPO patent (GH, GM, KE, LS, MW, SD, SZ, UG, ZW), Eurasian patent (AM, AZ, BY, KG, KZ, MD, RU, TJ, TM), European patent (AT, BE, CH, CY, DE, DK, ES, FI, FR, GB, GR, IE, IT, LU, MC, NL, PT, SE), OAPI patent (BF, BJ, CF, CG, CI, CM, GA, GN, GW, ML, MR, NE, SN, TD, TG).</p> <p><b>Published</b> <i>Without international search report and to be republished upon receipt of that report.</i></p>
<p><b>(54) Title:</b> SPLITTERLESS MULTICARRIER MODEM</p> <p><b>(57) Abstract</b></p> <p>A modem for use in Digital Subscriber Line communications transmits and receives data over the local subscriber loop in common with voice information over the loop, while avoiding the need for voice/data splitters. The modem responds to disruptions associated with "disturbance events" such as on-hook to off-hook transitions and the like by rapidly switching between pre-stored channel parameter control sets defining communications over the loop under varying conditions. In addition to changing parameter control sets responsive to a disturbance event, the modem may also change transmission power levels and other system parameters such as frequency domain equalizer characteristics. Further, provisions are made for reduced bandwidth communications under selected conditions.</p>		

**FOR THE PURPOSES OF INFORMATION ONLY**

Codes used to identify States party to the PCT on the front pages of pamphlets publishing international applications under the PCT.

<b>AL</b>	Albania	<b>ES</b>	Spain	<b>LS</b>	Lesotho	<b>SI</b>	Slovenia
<b>AM</b>	Armenia	<b>FI</b>	Finland	<b>LT</b>	Lithuania	<b>SK</b>	Slovakia
<b>AT</b>	Austria	<b>FR</b>	France	<b>LU</b>	Luxembourg	<b>SN</b>	Senegal
<b>AU</b>	Australia	<b>GA</b>	Gabon	<b>LV</b>	Latvia	<b>SZ</b>	Swaziland
<b>AZ</b>	Azerbaijan	<b>GB</b>	United Kingdom	<b>MC</b>	Monaco	<b>TD</b>	Chad
<b>BA</b>	Bosnia and Herzegovina	<b>GE</b>	Georgia	<b>MD</b>	Republic of Moldova	<b>TG</b>	Togo
<b>BB</b>	Barbados	<b>GH</b>	Ghana	<b>MG</b>	Madagascar	<b>TJ</b>	Tajikistan
<b>BE</b>	Belgium	<b>GN</b>	Guinea	<b>MK</b>	The former Yugoslav Republic of Macedonia	<b>TM</b>	Turkmenistan
<b>BF</b>	Burkina Faso	<b>GR</b>	Greece	<b>ML</b>	Mali	<b>TR</b>	Turkey
<b>BG</b>	Bulgaria	<b>HU</b>	Hungary	<b>MN</b>	Mongolia	<b>TT</b>	Trinidad and Tobago
<b>BJ</b>	Benin	<b>IE</b>	Ireland	<b>MR</b>	Mauritania	<b>UA</b>	Ukraine
<b>BR</b>	Brazil	<b>IL</b>	Israel	<b>MW</b>	Malawi	<b>UG</b>	Uganda
<b>BY</b>	Belarus	<b>IS</b>	Iceland	<b>MX</b>	Mexico	<b>US</b>	United States of America
<b>CA</b>	Canada	<b>IT</b>	Italy	<b>NE</b>	Niger	<b>UZ</b>	Uzbekistan
<b>CF</b>	Central African Republic	<b>JP</b>	Japan	<b>NL</b>	Netherlands	<b>VN</b>	Viet Nam
<b>CG</b>	Congo	<b>KE</b>	Kenya	<b>NO</b>	Norway	<b>YU</b>	Yugoslavia
<b>CH</b>	Switzerland	<b>KG</b>	Kyrgyzstan	<b>NZ</b>	New Zealand	<b>ZW</b>	Zimbabwe
<b>CI</b>	Côte d'Ivoire	<b>KP</b>	Democratic People's Republic of Korea	<b>PL</b>	Poland		
<b>CM</b>	Cameroon	<b>KR</b>	Republic of Korea	<b>PT</b>	Portugal		
<b>CN</b>	China	<b>KZ</b>	Kazakstan	<b>RO</b>	Romania		
<b>CU</b>	Cuba	<b>LC</b>	Saint Lucia	<b>RU</b>	Russian Federation		
<b>CZ</b>	Czech Republic	<b>LI</b>	Liechtenstein	<b>SD</b>	Sudan		
<b>DE</b>	Germany	<b>LK</b>	Sri Lanka	<b>SE</b>	Sweden		
<b>DK</b>	Denmark	<b>LR</b>	Liberia	<b>SG</b>	Singapore		
<b>EE</b>	Estonia						

## SPLITTERLESS MULTICARRIER MODEM

### Cross-reference to related applications:

This application is based in part on the following applications filed by one or more of the inventors herein:

5 U.S. Provisional Patent Application Serial No. 60/061,689, filed October 10, 1997 by Richard Gross, John Greszcuk, Dave Krinsky, Marcos Tzannes, and Michael Tzannes and entitled "Splitterless Multicarrier Modulation For High Speed Data Transport Over telephone Wires";

10 U.S. Provisional Patent Application Serial No. \*\*\*\* filed January 16, 1998 by Richard Gross and Michael Tzannes and entitled "Dual Rate Multicarrier Transmission System In A Splitterless Configuration";

U.S. Provisional Patent Application Serial No. \*\*\* filed January 21, 1998 by Richard Gross, Marcos Tzannes and Michael Tzannes and entitled "Dual Rate Multicarrier Transmission System In A Splitterless Configuration".

15 U.S. Provisional Patent Application Serial No. \*\*\* filed January 26, 1998 by Richard Gross, Marcos Tzannes and Michael Tzannes and entitled "Multicarrier System With Dynamic Power Levels".

The disclosures of these applications are incorporated by reference herein in their entirety.

### 20 **Background of the invention**

#### **A. Field of the invention.**

The invention relates to telephone communication systems and, more particularly, to telephone communication systems which utilize discrete multitone modulation to transmit data over digital subscriber lines.

#### 25 **B. Prior art.**

The public switched telephone network (PSTN) provides the most widely available form of electronic communication for most individuals and businesses. Because of its

SUBSTITUTE SHEET (RULE 26)

-2-

ready availability and the substantial cost of providing alternative facilities, it is increasingly being called upon to accommodate the expanding demands for transmission of substantial amounts of data at high rates. Structured originally to provide voice communication with its consequent narrow bandwidth requirements, the PSTN increasingly relies on digital systems to meet the service demand.

A major limiting factor in the ability to implement high rate digital transmission has been the subscriber loop between the telephone central office (CO) and the premises of the subscriber. This loop most commonly comprises a single pair of twisted wires which are well suited to carrying low-frequency voice communications for which a bandwidth of 0-4 kHz is quite adequate, but which do not readily accommodate broadband communications (i.e., bandwidths on the order of hundreds of kilohertz or more) without adopting new techniques for communication.

One approach to this problem has been the development of discrete multitone digital subscriber line (DMT DSL) technology and its variant, discrete wavelet multitone digital subscriber line (DWT DSL) technology. These and other forms of discrete multitone digital subscriber line technology (such as ADSL, HDSL, etc.) will commonly be referred to hereinafter generically as "DSL technology" or frequently simply as "DSL". The operation of discrete multitone systems, and their application to DSL technology, is discussed more fully in "Multicarrier Modulation For Data Transmission: An Idea Whose Time Has Come.", IEEE Communications Magazine, May, 1990, pp. 5-14.

In DSL technology, communications over the local subscriber loop between the central office and the subscriber premises is accomplished by modulating the data to be transmitted onto a multiplicity of discrete frequency carriers which are summed together and then transmitted over the subscriber loop. Individually, the carriers form discrete, non-overlapping communication subchannels of limited bandwidth; collectively, they form what is effectively a broadband communications channel. At the receiver end, the carriers are demodulated and the data recovered from them.

The data symbols that are transmitted over each subchannel carry a number of bits that may vary from subchannel to subchannel, dependent on the signal-to-noise ratio (SNR) of the subchannel. The number of bits that can be accommodated under specified

**SUBSTITUTE SHEET (RULE 26)**

-3-

communication conditions is known as the "bit allocation" of the subchannel, and is calculated for each subchannel in a known manner as a function of the measured SNR of the subchannel and the bit error rate associated with it.

The SNR of the respective subchannels is determined by transmitting a reference  
5 signal over the various subchannels and measuring the SNR's of the received signals. The loading information is typically calculated at the receiving or "local" end of the subscriber line (e.g., at the subscriber premises, in the case of transmission from the central telephone office to the subscriber, and at the central office in the case of transmission from the subscriber premises to the central office) and is communicated to the other (transmitting or  
10 "remote") end so that each transmitter-receiver pair in communication with each other uses the same information for communication. The bit allocation information is stored at both ends of the communication pair link for use in defining the number of bits to be used on the respective subchannels in transmitting data to a particular receiver. Other subchannel parameters such as subchannel gains, time and frequency domain equalizer coefficients,  
15 and other characteristics may also be stored to aid in defining the subchannel.

Information may, of course, be transmitted in either direction over the subscriber line. For many applications, such as the delivery of video, internet services, etc. to a subscriber, the required bandwidth from central office to subscriber is many times that of the required bandwidth from subscriber to central office. One recently developed service  
20 providing such a capability is based on discrete multitone asymmetric digital subscriber line (DMT ADSL) technology. In one form of this service, up to two hundred and fifty six subchannels, each of 4312.5 Hz bandwidth, are devoted to downstream (from central office to subscriber premises) communications, while up to thirty two subchannels, each also of 4312.5 Hz bandwidth, provide upstream (from subscriber premises to central office) communications. Communication is by way of "frames" of data and control information. In a presently-used form of ADSL communications, sixty eight data frames and one  
25 synchronization frame form a "superframe" that is repeated throughout the transmission. The data frames carry the data that is to be transmitted; the synchronization or "sync" frame provides a known bit sequence that is used to synchronize the transmitting and receiving modems and that also facilitates determination of transmission subchannel characteristics such as signal-to-noise ratio ("SNR"), among others.  
30

**SUBSTITUTE SHEET (RULE 26)**

Although such systems do in fact provide a significantly increased bandwidth for data communications, special precautions are required to avoid interference with, and from, ordinary voice communications and associated signaling that may be taking place over the subscriber line at the same time that the broadband data is being carried. The signaling activities commonly include, for example, the transmission of ringing signals, busy tone, off-hook indications, on-hook indications, dialing signals, and the like, and the actions commonly accompanying them, e.g., taking the phone off-hook, replacing it on-hook, dialing, etc. These voice communications and their associated signaling, commonly referred to as "plain old telephone service" or POTS, presently are isolated from the data communications by modulating the data communications onto frequencies that are higher than those used for POTS; the data communications and POTS signals are thereafter separately retrieved by appropriate demodulation and filtering. The filters which separate the data communications and the POTS are commonly referred to as "POTS splitters".

The voice and data communications must be separated at both the central office and the subscriber premises, and thus POTS splitters must be installed at both locations. Installation at the central office is generally not a significant problem, since a single modem at the central office can serve a large number of subscribers, and technicians are commonly available there. Installation at the customer premises is a problem. Typically, a trained technician must visit the premises of every subscriber who wishes to use this technology in order to perform the requisite installation. In connection with this, extensive rewiring may have to be done, dependent on the desired location of the ADSL devices. This is expensive and discourages the use of DSL technology on a widespread basis.

DSL systems also experience disturbances from other data services on adjacent phone lines (such as ADSL, HDSL, ISDN, or T1 service). These services may commence after the subject ADSL service is already initiated and, since DSL for internet access is envisioned as an always-on service, the effect of these disturbances must be ameliorated by the subject ADSL transceiver.

**Summary of the invention**



**A. Objects of the invention**

Accordingly, it is an object of the invention to provide an improved digital subscriber line communication system.

Further, it is an object of the invention to provide a digital subscriber line communication system which is compatible with existing voice communication services and which does not require the use of POTS splitters.

Another object of the invention is to provide an improved digital subscriber line communication system that efficiently handles data communications despite random interruptions associated with concurrent carriage of voice communications or disturbances that arise from concurrent data services on adjacent phone lines.

**B. Summary description of the invention.***Splitterless Operation*

The invention described herein is directed to enhancing the accuracy and reliability of communications in systems using discrete multitone technology (DMT) to communicate data over digital subscriber lines (DSL) in the presence of voice communications and other disturbances. For simplicity of reference, the apparatus and method of the present invention will hereinafter be referred to collectively simply as a modem. One such modem is typically located at a customer premises such as a home or business and is “downstream” from a central office with which it communicates; the other is typically located at the central office and is “upstream” from the customer premises. Consistent with industry practice, the modems are often referred to herein as “ATU-R” (“ADSL Transceiver Unit, Remote”, i.e., located at the customer premises) and “ATU-C” (“ADSL Transceiver Unit, Central Office”). Each modem includes a transmitter section for transmitting data and a receiver section for receiving data, and is of the discrete multitone type, i.e., it transmits data over a multiplicity of subchannels of limited bandwidth. Typically, the upstream or ATU-C modem transmits data to the downstream or ATU-R modem over a first set of subchannels, commonly the higher-frequency subchannels, and receives data from the downstream or ATU-R modem over a second, usually smaller, set of subchannels, commonly the lower-frequency subchannels.

-6-

Heretofore, such modems have required POTS splitters when used on lines carrying both voice and data. In accordance with the present invention, we provide a data modem for use in discrete multitone communication systems which carry voice and data communications simultaneously and which operate without the special filtering provided by POTS splitters; they are thus "splitterless" modems. In the absence of certain disturbances, referred to herein as "disturbance events" and discussed more fully hereinafter, the modem of our invention transmits data at a rate determined by the transmission capabilities of the system without regard to such disturbances. Preferably, this is the maximum data rate that can be provided for the particular communications subchannel, subject to predefined constraints such as maximum bit error rate, maximum signal power, etc. that may be imposed by other considerations. On the occurrence of a disturbance event on the communications channel, however, the modem of the present invention detects the event and thereupon modifies the subsequent communication operations. Among other responses, the modem changes the bit allocations (and thus possibly the corresponding bit rate) and the subchannel gains among the subchannels, so as to limit interference with and from voice communication activities or to compensate for disturbances from other services or sources sufficiently close to the subject subscriber line as to couple interfering signals into the line. The bit allocations and subchannel gains may be altered for communications in either direction, i.e., upstream, downstream, or both. Effectively, this matches the subchannel capacity to the selected data rate so as to ensure that the pre-specified bit error rate is not exceeded. On cessation of the disturbance event, the system is returned to its initial, high-rate, state.

#### *Disturbance Events*

Of particular interest to the present invention are disturbance events that arise from the occurrence of voice communication activities over the data link concurrent with the transmission of data over the link. These activities comprise the voice communications themselves, or activities such as signaling associated with such communications, together with the response to such activities, such as taking a phone off-hook or placing it on-hook. Disturbance events also include other disruptive disturbances such as interference from adjacent phone lines caused, for example, by the presence of other DSL services, ISDN services, T1 services, etc. The cessation of a disturbance event may itself also

**SUBSTITUTE SHEET (RULE 26)**

-7-

comprise a disturbance event. For example, the change of a voice communications device such as a telephone from "on-hook" to "off-hook" status can seriously disrupt communications at a modem unless compensated for as described herein or unless otherwise isolated from the modem by means of a POTS splitter as was heretofore done; it is thus a disturbance event that must be dealt with. However, the return of such a device to "on-hook" status can also significantly change the channel characteristics and is therefore also a disturbance event that must be dealt with. The invention described herein efficiently addresses these and other disturbance events.

#### *Channel Control Parameter Sets*

10 In accordance with the present invention, the change in bit allocation is accomplished rapidly and efficiently by switching between stored parameter sets which contain one or more channel control parameters that define data communications by the modem over the subchannels. The parameters sets are preferably determined at the time of initialization of the modem and stored in registers or other memory (e.g., RAM or ROM) in  
15 the modem itself, but may instead be stored in devices external to, and in communication with, the modem, e.g., in personal computers, on disk drives etc.

In accordance with one embodiment of this invention, the channel control parameter sets comprise at least a primary set of channel control parameters, stored in a primary channel control table, which defines communications in the absence of voice communication activities or other disturbances; and one or a plurality of secondary sets of channel  
20 control parameters, stored in a secondary channel control table, that define data communications responsive to one or more disturbance events. When communicating under control of the primary channel control table, the modem is described hereinafter as being in its "primary" state; when communicating under control of the secondary channel control table, the modem is described hereinafter as being in its "secondary" state. The  
25 modem is switched between parameter sets in its primary and secondary states responsive to the occurrence and cessation of disturbance events, as well as among parameter sets in the secondary table responsive to a change from one disturbance event to another. Since the parameter sets are pre-stored and thus need not be exchanged at the time of a disturbance  
30 event, the switch is made quickly, limited essentially only by the speed with which the disturbance event is detected and signaled to the other modem participating in the com-

**SUBSTITUTE SHEET (RULE 26)**

-8-

munication, typically not more than a second or so. This greatly reduces the interruption in communications that would otherwise be required by a complete reinitialization of the modems that typically extends over six to ten seconds, and its associated exchange channel control parameters.

5 As noted previously, in DSL communications, information transmission typically takes place in both directions, i.e. the upstream or ATU-C modem transmits downstream to the ATU-R modem over a first set of subchannels, and the downstream or ATU-R modem transmits upstream to the ATU-C modem over a second, different, set of subchannels. The transmitter and receiver at each modem, accordingly, maintain corresponding  
10 channel tables to be used by them in transmitting data to, and receiving data from, the other modem with which it forms a communications pair. Certain parameters such as time and frequency domain equalizer coefficients and echo canceller coefficients are “local” to the receiver with which they are associated, and thus need be maintained only at that receiver. Other parameters such as bit allocations and channel gains are shared with  
15 the other modem with which a given modem is in communication (the “modem pair”) and thus are stored in both modems, so that during a given communication session, the transmitter of one modem will use the same set of values of a shared parameter as the receiver of the other modem, and vice versa.

In particular, in DSL communications, a key parameter is the number of bits that  
20 are to be transmitted over the various subchannels. This is known as the “bit allocation” for the respective subchannels, and is a key element of the primary and secondary parameter sets. It is calculated in a known manner for each subchannel based on the channel SNR, the acceptable bit error rate, and the noise margin of the subchannel. Another important element is the gain for each of the subchannels, and is thus preferably also included in the primary and secondary parameter sets. Thus, each receiver stores a primary  
25 channel control table and a secondary channel control table, each of which contains one or more parameter sets that define the subchannel bit allocations to be used by it and by the transmitter of the other modem in communicating with it, and each transmitter also stores a primary channel control table and a secondary channel control table, each of which  
30 define the subchannel bit allocations and gains to be used by it for transmission to the other receiver and for reception at that receiver. For the closest match to the actual line over

**SUBSTITUTE SHEET (RULE 26)**

which they are to communicate, those portions of the primary and secondary channel control table at each receiver that define the parameters for use in transmitting to the particular receiver are preferably determined at the modem at which the receiver is located (the "local modem"), as described herein, but it will be understood from the detailed description herein that such tables may also be determined in other ways.

As long as communications over the subscriber line are not impaired by a disturbance event, the modems use the primary channel control table to define communications over the subchannels. When, however, a disturbance event occurs, the modem that detects the event (herein designated "the local modem"; typically, this will be the subscriber modem, ATU-R, particularly in cases of activation of a voice communications device by the subscriber) notifies the other modem of the need to change to the secondary channel control table, and identifies the specific bit allocation set and/or gain set in the secondary table when more than one such set exists. The notification procedure is described in more detail hereinafter. Communications thereafter continue in accordance with the appropriate parameter set (i.e., bit allocations, subchannel gains, and possibly other parameters) from the secondary channel control table. This condition continues until a new disturbance event is detected, at which time the modems revert to the primary channel control table (in the event the disturbance is simply the cessation of communication-disrupting disturbances or interferences) or to a different parameter set secondary channel control table (in the event that the disturbance event is the occurrence of another communication-disrupting disturbance or interference).

In addition to changes in bit allocation among the subchannels, and changes in subchannel gains, further changes may also be made in such communication parameters as time domain equalizer coefficients, frequency domain equalizer coefficients, and the like. These parameters may also be stored in the channel control tables for use in controlling communications, or may be stored in separate tables. Additionally, changes in power level (and corresponding changes in bit allocation and other communication parameters) for communications in either the upstream or the downstream direction, or both, may be made, and sets of control parameters may be defined on these power levels as well for use in controlling communications. These changes are described in fuller detail below.

As presently contemplated, each modem on the subscribed side of the DSL line will communicate with a corresponding dedicated modem on the central office side. Thus, each central office modem (ATU-C) need store the primary and secondary tables for a specific subscriber only. However, efficiencies may be achieved whenever it is unnecessary to provide service to each subscriber at all times. Under these circumstances, a central office modem may be shared among two or more subscribers, and switched among them as called for. In such a case, the ATU-C will store or have access to a set of channel control tables for each subscriber modem it is to service.

*Table Initialization*

In the preferred embodiment of the invention, the primary and secondary channel control tables are determined in an initial "training" session ("modem initialization") in which known data is transmitted by one modem, measured on reception by the other, and the tables calculated based on these measurements. Typically, the training session occurs when the modem is first installed at the subscriber premises or at the central office, and the procedure thus "particularizes" the modem to the environment in which it will operate. This environment includes, in addition to the subject data modem, one or more voice communication devices such as telephone handsets, facsimile machines, and other such devices which communicate over a voice frequency subchannel, typically in the range 0-4 kHz. A primary channel control table, comprising a parameter set including at least a set of subchannel bit allocations, and preferably also subchannel gains, is calculated with each device inactive. A secondary channel control table comprising one or more bit communication parameter sets (bit allocations, gains, etc.) is calculated with each voice communication device activated separately, and/or with groups of devices activated concurrently. The tables so determined are then stored at the receiver of one modem and additionally are communicated to the transmitter of the other modem and stored there for use by both modems in subsequent communications.

An alternative approach determines the secondary channel control table (including one or more parameter sets comprising the table) by calculation from the primary channel control table. This is accomplished most simply, for example, by taking one or more of the parameters (e.g., the bit allocation parameter which defines the number of bits to be used for communication across the respective subchannels) as a percentage, fixed or

varying across the subchannels, of the corresponding primary parameters; or as determined in accordance with a percentage, fixed or varying across the subchannels, of the SNR's of the respective subchannels; or as determined in accordance with a different bit error rate than provided for in the primary channel control table; or by other techniques.

5           As a specific example, a number of different sets of bit allocations in the secondary channel control table may be determined as differing percentages (fixed or varying across the subchannels) of the corresponding set of bit allocations in the primary channel control table. Each secondary bit allocation set corresponds to the effect commonly produced by a particular device or class of devices, e.g., a telephone handset, a facsimile machine, etc.,  
10 as determined by repeated measurements on such devices, and thus may be taken to represent the expected effect of that device over a range of communication conditions, e.g., with a particular type of subscriber line wiring, at a given range from the central office, etc. The subchannel gains may also then be adjusted based on the redetermined bit allocations. The bit allocations and subchannel gains so determined form new secondary pa-  
15 rameter sets which may be used responsive to detection of the disturbance events they characterize, and which substitute for determination of the secondary bit allocations and gains on the basis of measurements of the actual disturbances being compensated for.

          Alternatively, the secondary channel control table may be determined by adding a power margin to the calculations for each of the entries of the primary table of a magni-  
20 tude sufficient to accommodate the interference from activation of the voice communications device or from other disturbances. This has the effect of reducing the constellation size for the table entries. The margin may be uniform across the table entries, or may vary across them, as may the percentage factor when that approach is used. Multiple secondary bit allocation sets may be defined by this approach, each based on a different power  
25 margin.

          One example of the use of varying margins is in response to changes in crosstalk (capacitively coupled noise due to nearby xDSL users, where the "x" indicates the possible varieties of DSL such as ADSL, HDSL, etc.). This crosstalk is, in general, more predictable than signaling events associated with voice communications. The crosstalk spec-  
30 trum of xDSL sources is well characterized: see, for example, the T1.413 ADSL standard published by the American National Standards Institute. From a primary channel control

table associated with a single full initialization, a secondary table comprising a family of bit allocation sets can be calculated, each corresponding to a different crosstalk level. As the number of xDSL systems (and thus crosstalk levels) changes, the ADSL link can quickly switch to one of these automatically generated sets.

5           The secondary channel control table in the present invention may also be adapted dynamically, e.g., by performing measurements on the transmitted information in each superframe during data communications and monitoring these measurements to determine when the channel performance has sufficiently changed that a different bit allocation set, and possibly different gain set, should be used. We have found that the SNR provides a  
10 readily measurable and reliable indicator of the required bit allocations and gains.

In particular, we have found that measurements of the SNR levels across a number of the subchannels during a given communications condition or state provides a “fingerprint” which may reliably be used to quickly select a parameter set, such as the set of bit allocations or the set of gains, for use in subsequent communications during that  
15 state. These measurements may be made, for example, on the sync frame that occurs in each superframe or, more generally, during the transmission of reference frames. When the SNR’s change by more than a defined amount during communications, the modem at which the measurement is made searches the stored parameter sets for a set whose SNRs on the corresponding subchannels is closest to the measured SNRs, and selects that set  
20 for use in subsequent communications. If no parameter set is found within defined limits, the system may be switched to a default state, or a complete reinitialization may be called for, corresponding to a defined pattern of SNR’s across some or all of the subchannels, should be used. SNR measurements may also be made on the data carrying signals themselves, i.e., a decision-directed SNR measurement.

25           Instead of using a multiplicity of secondary subchannel control parameter sets as described above, a simplified approach may construct and use a single secondary set based on a composite of the bit allocation or other characteristics of the individual devices. In one embodiment, the composite is formed by selecting, for each subchannel, the minimum bit allocation exhibited by any device for that subchannel, or the most severe  
30 characteristic of any other disturbances, thus forming a single “worst case” set that may be used when any device is activated, regardless of the specific device or disturbance ac-

**SUBSTITUTE SHEET (RULE 26)**



5 tually present. Or it may be determined as the actual or calculated capacity of the line when all devices are actually or theoretically actuated simultaneously, or all disturbances are present, or both concurrently. Bit allocations sets may also be determined for combinations of subsets of such devices and disturbances. A similar approach may be used to handle the situation where several devices are activated at the same time, and the effects of other disturbances such as cross talk, etc. may also be incorporated into a composite set.

10 A particular parameter set of the secondary channel control table remains in use for the duration of the session in which the voice device is active or until another change of state occurs, e.g., a further voice device is activated or some other disturbance takes place. When this occurs, the local modem renews its identification procedure to enable determination of the appropriate parameter set for the new conditions. At the end of the session in which the voice device is active, the device returns to inactive (i.e., "on-hook") status and the system reverts to its original ("on-hook") status in which the primary channel control table once again is used for communications between the central office and the subscriber.

15 Switching the subchannel parameter sets in accordance with the present invention is extremely fast. It can be accomplished in an interval as short as several frames, and thus avoids the lengthy (e.g., several second) delay that would otherwise accompany determination, communication, and switching of newly-determined sets. Further, it avoids communicating new parameter sets at a time when communications have been impaired and error rates are high. Thus, it minimizes disruption to the communication process occasioned by disturbance events.

#### *Detecting Disturbance Events*

25 During subsequent data communications, identification of the device that is activated is achieved in one of a number of ways. In one embodiment of the invention, a specific activation signal is transmitted from the device to the modem on the same side of the subscriber line as the device (referred to herein as "the local modem") on activation of the device. This signal may be transmitted over the communications line to which the device and the local modem are connected or it may be sent over a dedicated connection

30

-14-

between the device and the local modem.

In the preferred embodiment of the invention, the local modem monitors the subscriber line to which it and the device are connected and detects a change in line characteristics when the device is activated. For example, the signal to noise ratio (SNR) of the various subchannels can quickly be measured and can be used to identify the particular device that is activated. During multiple sets of initializations, corresponding to multiple communication conditions caused by the devices or by other interferences, the SNR measure for each subchannel is determined for each of the conditions to be tracked (i.e., no devices activated, devices activated separately, two or more devices activated concurrently, adjacent channel interference, etc.) and the measures stored, along with identification of the particular parameter set or sets with which they are associated. When a device is activated, the SNR measurements are used to quickly identify the particular device or devices that have been activated, and the local modem can thereafter switch to the appropriate secondary table.

Disturbance events may also be detected in accordance with the present invention by monitoring selected transmission characteristics that are dependent on these events. These may comprise, in addition to any characteristic SNR accompanying them, such measures as errors in the cyclic redundancy code (CRC) that accompanies transmissions and changes in the error rate of this code; changes in the amplitude, frequency or phase of a pilot tone on the subchannels; or other such indicia. Forward error correction code (FEC) is typically used in ADSL transceivers, and changes in the error rate characteristics of this code, such as how many errors have occurred, how many have been corrected, how many are uncorrected, and the like, can be particularly useful in detecting disturbance events.

In monitoring these characteristics, we distinguish between changes caused by momentary or transient events such as lightning or other such burst noise disturbances, and those associated with disturbance events, the latter continuing for a significant interval (e.g., on the order of seconds or more). In particular, in embodiments that monitor CRC errors or error rates in accordance with the present invention, a switch from one parameter set to another is provided when the errors extend over a number of frames or when the error rate changes by a defined amount for a time greater than a defined mini-

**SUBSTITUTE SHEET (RULE 26)**

num. For example, on the occurrence of an off-hook event, a severe form of disturbance to data communications over a subscriber loop, the number of CRC errors suddenly increases and remains at an increased level until it is dealt with. This is distinguished from the occurrence of a transient disturbance such as a lightning strike which causes a momentary increase in CRC errors that does not persist as long as the system has not lost synchronization.

Thus, in accordance with the present invention, the detection of an initial change in the CRC error rate over a number of frames in excess of a defined threshold is one example of the detection of a disturbance event that will result in switching parameter sets. Similar procedures may be undertaken in response to measurement of the signal-to-noise ratio of the subchannel in order to detect a disturbance event based on this characteristic. The decision as to whether a disturbance event has occurred may be based on measurements on a single subchannel; on a multiplicity of subchannels (e.g., the decision to switch parameter sets will be made when more than a defined number of subchannels detect a disturbance event); or the like.

An alternative technique for detecting a disturbance event in accordance with the present invention is the use of a monitor signal, e.g., a pilot tone whose amplitude, frequency, phase or other characteristic is monitored during data transmission. A sudden change in one or more of the monitored characteristics from one frame to another, followed by a smaller or no change in subsequent frames, indicates a disturbance event to which the modem should respond. The monitor signal may comprise a dedicated signal carried by one of the subchannels; a signal carried on a separate control subchannel; a disturbance event itself (e.g., ringing tone, dial tone presence, or other common telephone signals); or other signals.

#### *Communicating The Occurrence of Disturbance Events*

After a disturbance event is detected and the appropriate parameter set corresponding to the event is identified, the identification is communicated to the remote modem by means of a selection signal to enable it also to switch to the corresponding parameter set in the secondary table. The selection signal may be in the form of a message transmitted over one or more subchannels or using a predetermined protocol for an em-

-16-

bedded operations channel, or it may comprise one or more tones that identify the particular parameter set. ADSL systems use a "guard band" of several subchannels between the sets of subchannels used for upstream and downstream transmission. This guard band may be used to transmit the selection tone or tones. In cases where there is only a single parameter set to be designated, the selection signal may comprise a simple flag (an element that has only two states, i.e., on/off, present/absent, etc.) that is sent to the remote modem to select the set.

In a further embodiment of the invention, use is made of the frame counters at the ATU-R and ATU-C modems that are commonly provided in DSL systems. On detecting a disturbance event, the ATU-R modem notifies the ATU-C modem of the event and specifies a frame at which the change in parameter set, or change in power level and any accompanying change in other parameters, is to take place. The specification may be direct (i.e., the notification specifies a particular frame number at which the change to the secondary table is to be made) or indirect (i.e., on receipt of the notification, the change to the secondary table is made at one of a predetermined number of frames, e.g., the next frame number ending in "0", or in "00", etc., or the nth frame after receiving the notification, where n is some number greater than 0). On reaching the designated frame, both modems (i.e., ATU-R and ATU-C) switch to the new bit allocation set, power level, and other designated parameters.

Alternatively, on detection of a disturbance event, the modems perform a "fast retrain" in order to characterize communications under the new operating conditions and determine a power and/or bit allocation set to be used for the communications. A fast retrain performs only a limited subset of the full initialization procedures, e.g., bit allocation and subchannel gain determination. The retraining modem (typically the modem local to the disturbance initiating the retraining) then compares the newly determined parameter set with previously stored sets. If the newly-determined set is the same as a previously stored set, a message, flag, or tone is communicated by one modem to the other to designate which of the stored secondary allocation sets is to be used. Otherwise, the newly determined set is used for communications. In the latter event, it must be communicated to the other modem in the communication pair, and communications may be interrupted while this occurs. Nonetheless, on cessation of the event which necessitated a

**SUBSTITUTE SHEET (RULE 26)**

change in parameter sets, the system may simply revert to the primary parameter set, without need for recommunication of that set and thus without further interrupting communications. With proper care in initialization, in most cases a sufficient array of parameter sets may be defined and exchanged at the outset as to avoid the need for subsequent  
5 reinitialization in response to most disturbances.

### *Changing Power Levels*

In addition to changing one or more parameter sets in the modem in response to a disturbance event, in accordance with the preferred embodiment of the present invention we also preferably change the communications power level in either the upstream or the  
10 downstream direction, or both, in order to further enhance reliable communications. Typically, the change is a reduction in the power level in the upstream direction so as to minimize interference with the voice communications, as well as to reduce echo into the downstream signal, and it will be so described herein. However, it should be understood that there will be some occasions when an increase in power level is called for, such as  
15 when interference from adjacent data services requires a higher power level in order to maintain a desired data rate or bit error level, and such a change is accommodated by the present invention in the same manner as that of a decrease. Further, a change in downstream power level may be called for when line conditions change to such an extent that excessive power would otherwise be fed into the downstream channel from the upstream  
20 modem

In theory, and in a perfectly linear system, upstream communications activities should have no effect on concurrent voice communications since the two activities occur in separate, non-overlapping frequency bands. However, the telephone system in fact is not a linear system, and nonlinearities in the system can and do inject image signals from  
25 the upstream subchannel into the voice subchannel, and possibly into the downstream subchannel as well (i.e., echo), thus producing detectable interference. In accordance with another aspect of the present invention, this effect is reduced below the level of objection by reducing the upstream power level (the power level at which the subscriber or downstream modem transmits to the central office or upstream modem) by a given  
30 amount or factor when conditions dictate, e.g., when a voice communications device is off-hook and leakage from the data communications being conducted interferes with the

**SUBSTITUTE SHEET (RULE 26)**

-18-

voice communications.

The amount of power reduction may be set in advance. For example, we have found that a nine db reduction in this power (relative to that typically used in ADSL applications using splitters to separate the data and POTS signals) is sufficient in most cases of common interest; under these circumstances, the system operates in one of two alternative power levels at all times. Alternatively, the downstream modem may select one of several different power levels for use, based on the communication conditions prevailing at the time resultant from the disturbance event. For example, the downstream modem may be activated to send a test signal into one or more upstream subchannels and to monitor the leakage (i.e., the echo) of this signal into one or more downstream subchannels as determined, for example, by the SNRs on these subchannels; the power level at which the downstream modem transmits upstream may then be adjusted accordingly in order to minimize the effects of the echo. Commonly, the downstream transmit power is determined by the ATU-R, since the ATU-R is closest to the cause of the disturbance event. In this event, the ATU-R uses a message, flag, or tone to inform the ATU-C of the desired power level to be used for transmission. In either case, at the end of a session, the power level reverts to that used in the "on-hook" state.

In selecting the desired power level, the transmitting modem signals the receiving modem in the communications-pair of the desired change (including the designation of a particular power level from among several power levels, where appropriate), and thereafter implements the change, including switching to a new parameter set associated with that power level. In another embodiment of the invention, the receiving modem detects the power level change at the transmitting modem and switches to a parameter set associated with that power level; upstream communications (i.e., from the ATU-R to the ATU-C) are thereafter conducted at the new power level until the disturbance event (e.g., off-hook condition, etc.) terminates.

While much of the above has been described in terms of a change in power level in the upstream communications from the subscriber modem to the central office modem, it should be noted that a change in power level in the opposite direction may also sometimes be called for. This may be the case, for example, on short subscriber loops (e.g., less than a mile), where the reduced line loss consequent on the greater proximity to the central

**SUBSTITUTE SHEET (RULE 26)**

office may result in the central office initially transmitting at an excessive power level. In such cases, the central office or ATU-C modem performs the role previously performed by the subscriber or ATU-R modem, and vice versa, and a change in power level and other parameters on the downstream communications may be performed as described above. Further, it should also be understood that while it is expected that the power change will most commonly be one that reduces the power level used to communicate, it may in some cases increase it. This will occur, for example, when crosstalk from adjacent services requires an increase in power level of the subject service in order to compensate for the crosstalk.

10 *Changing Other Parameters*

A further important change made in response to detecting a disturbance event is a change in the frequency domain equalizers ("FDQ's") associated with each subchannel. These equalizers compensate for the differing distortions (e.g., amplitude loss, phase delay, etc.) suffered by the data during transmission over the subchannel. Typically, they comprise finite impulse response filters with complex coefficients. The coefficients are set during the "initialization" or "training" phase of modem setup. They may subsequently be adjusted based on reference (known) data in reference frames or sync frames transmitted over the communication subchannel. In accordance with the present invention, these filters are adjusted responsive to the transmitted reference data when a disturbance event is detected. The coefficient updating may be performed on all subchannels, or selectively on those whose change in error rates, signal-to-noise ratios, or other error indicia, indicate a disturbance event.

In accordance with one embodiment of the present invention, the coefficients of the frequency domain equalizers for communications both in the absence of a disturbance event or disturbance ("primary FDQ coefficients") and in the presence of such an event or disturbance ("secondary FDQ coefficients") are computed and stored during the initialization or training period. Thereafter, these coefficients are switched responsive to a disturbance event, as is the case with the channel control tables, and are returned to an initial state on the cessation of such an event.

30 In accordance with another embodiment of the invention, the FDQ coefficients are

-20-

recomputed responsive to detection of a disturbance event and then used throughout the remainder of the communications session in place of the earlier-stored secondary FDQ tables. The recomputation is accomplished in a short "retrain" session in which known reference data is transmitted between the ATU-R and ATU-C. The received data is compared with the known data and the new FDQ coefficients are determined accordingly. In addition to the frequency domain equalizer coefficients, time domain equalizer coefficients and echo cancellation coefficients may also be determined and stored. Such coefficients are local to the particular receiver, and thus need not be communicated to the other modem of the communications pair. Accordingly, any such retrain will be extremely fast, and any consequent disruption to communication limited.

#### *Excessive Disturbances*

In some cases a particular device may cause such interference with communications that compensation for that device by the methods described herein is not practical. This may occur, for example, with antiquated telephones or with particularly complex in-home wiring. In such a case, it is desirable to minimize the disruption caused by such a device by inserting a simple in-line filter between the device and the subscriber line. The filter may comprise, for example, a simple low-pass filter of not more than a cubic inch in volume and a pair of standard connectors such as RJ11 connectors through which the filter connects to the device on one side and to the subscriber line on the other. Unlike POTS splitters, such a connector needs no trained technician to install it, and thus presents no barrier, cost or otherwise, to acceptance of ADSL modems as described herein. Such a device may be detected by measuring the nonlinear distortion of the device when it is activated. This is done by monitoring the echo on the line caused by that device.

#### *Reduced Rate Communications*

A further improvement in the operation of the modem of the present invention resides in confining the bandwidth of the downstream transmission to a subset of that normally provided in ADSL communications. This reduces the processing demands on both the local (i.e., central office) and remote (subscriber premises) modems, thereby facilitating the provision of subscriber premises modems at prices more acceptable to consumer, non-business, use; additionally, it further minimizes interference between data transmis-

SUBSTITUTE SHEET (RULE 26)



-21-

sion and voice communications. For example, limiting the number of subchannels used by the modem to one hundred and twenty eight as opposed to two hundred and fifty six reduces the downstream bandwidth from 1.1 MHz to approximately 552 kHz. When the modem is used with modems that normally provide a greater number of subchannels for such communications, the bit allocations and gains for the subchannels above one hundred and twenty eight are preferably nulled, i.e., set to zero.

The invention is preferably operable with modems that do not have the capabilities described herein, as well, of course, with modems that do. Accordingly, the modem of the present invention identifies its capabilities, preferably during initialization, preparatory to data exchange with another modem. In accordance with the preferred embodiment of the invention, this is preferably done by signaling between the modems that are to participate in communications. The signaling identifies the type of modems in communication and their characteristics of significance to the communication session. For example, one form of ADSL transceiver uses a reduced number of subchannels (typically, thirty two subchannels upstream and one hundred twenty eight subchannels downstream) and provides lower bandwidth communications. A modem having full ADSL capabilities that encounters a reduced-rate modem can then adjust its transmission and reception parameters to match the reduced-rate modem. This may be done, for example, by transmission from one modem to the other of a tone that is reserved for such purposes.

In particular, in accordance with the present invention, on initiation of communications between a central office modem and a subscriber premises modem, the modems identify themselves as "full rate" (i.e., communicating over two hundred and fifty six subchannels) or "reduced rate" (e.g., communicating over some lesser number of subchannels, e.g., one hundred and twenty eight). The communication may be performed via a flag (two-state, e.g., "on/off", "present/absent"), a tone or tones, a message (n-state,  $n > 2$ ), or other form of communication, and may be initiated at either end of the communication subchannel, i.e., either the central office end or the customer premises end.

#### **Brief description of the drawings**

The invention description below refers to the accompanying drawings, of which:

Figure 1 is a block and line diagram of a conventional digital subscriber line

**SUBSTITUTE SHEET (RULE 26)**

-22-

(DSL) system using POTS splitters that is characteristic of the prior art;

Figure 2 illustrates an illustrative bit allocation and gains table used in the apparatus of Figure 1;

Figure 3 is a block and line diagram of a splitterless DSL system in accordance with the present invention;

Figure 4 is a block diagram of a splitterless transceiver in accordance with the present invention;

Figures 5A-5C illustrates channel control tables constructed and used in accordance with the present invention;

Figure 6 is a diagram of one form of disturbance event detector in accordance with the present invention;

Figure 7 illustrates the use of a frame counter for communicating the switching decision to the remote modem;

Figure 8 illustrates the preferred procedure used for performing a fast retrain of the modems in accordance with the present invention;

Figure 9 illustrates the manner in which channel control tables may readily be selected in accordance with the present invention; and

Figure 10 illustrates alternative configuration for interconnection of the modems of the present invention.

#### **20 Detailed description of an illustrative embodiment**

Figure 1 shows an ADSL communications system of the type heretofore used incorporating "splitters" to separate voice and data communications transmitted over a telephone line. As there shown, a telephone central office ("CO") 10 is connected to a remote subscriber 12 ("CP: Customer Premises") by a subscriber line or loop 14. Typically, the subscriber line 14 comprises a pair of twisted copper wires; this has been the traditional medium for carrying voice communications between a telephone subscriber or customer and the central office. Designed to carry voice communications in a bandwidth of approximately 4 kHz (kilohertz), its use has been greatly extended by DSL technology.

-23-

The central office is, in turn, connected to a digital data network ("DDN") 16 for sending and receiving digital data, as well as to a public switched telephone network ("PSTN") 18 for sending and receiving voice and other low frequency communications. The digital data network is connected to the central office through a digital subscriber line access multiplexer ("DSLAM") 20, while the switched telephone network is connected to the central office through a local switch bank 22. The DSLAM 20 (or its equivalent, such as a data enabled switch line card) connects to a POTS "splitter" 24 through an ADSL transceiver unit -central office ("ATU-C") 26. The local switch 20 also connects to the splitter.

The splitter 24 separates data and voice ("POTS") signals received from the line 14. At the subscriber end of line 14, a splitter 30 performs the same function. In particular, the splitter 30 passes the POTS signals from line 14 to the appropriate devices such as telephone handsets 31, 32, and passes the digital data signals to an ADSL transceiver unit-subscriber ("ATU-R") 34 for application to data utilization devices such as a personal computer ("PC") 36 and the like. The transceiver 34 may advantageously be incorporated as a card in the PC itself; similarly, the transceiver 26 is commonly implemented as a line card in the multiplexer 20.

In this approach, a communication channel of a given bandwidth is divided into a multiplicity of subchannels, each a fraction of the subchannel bandwidth. Data to be transmitted from one transceiver to another is modulated onto each subchannel in accordance with the information-carrying capacity of the particular subchannel. Because of differing signal-to-noise ("SNR") characteristics of the subchannels, the amount of data loaded onto a subchannel may differ from subchannel to subchannel. Accordingly, a "bit allocation table" (shown as table 40 at transceiver 26 and table 42 at transceiver 34) is maintained at each transceiver to define the number of bits that each will transmit on each subchannel to the receiver to which it is connected. These tables are created during an initialization process in which test signals are transmitted by each transceiver to the other and the signals received at the respective transceivers are measured in order to determine the maximum number of bits that can be transmitted from one transceiver to the other on the particular line. The bit allocation table determined by a particular transceiver is then transmitted over the digital subscriber line 14 to the other transceiver for use by the other

**SUBSTITUTE SHEET (RULE 26)**

-24-

transceiver in transmitting data to that particular transceiver or to any similar transceiver connected to the line 14. The transmission must, of course, be done at a time when the line is not subject to disturbances which may interfere with communications. This is a significant limitation, and restricts the utilization of this approach.

5 Referring now to figure 2, a bit allocation table 42 such as is used in the customer premises equipment is shown in further detail. Table 40, used at the central office, is essentially the same in construction and operation and will not further be described. Table 42 has two sections, a first section, 42a, which defines certain communication parameters such as bit allocation capacity and subchannel gain parameters that characterize the re-  
10 spective subchannels and which the transmitter section of transceiver 34 will use in transmitting a signal to the other transceiver (26) with which it is in communication; and a section 42b that defines the parameters that the receiver section of transceiver 34 will use in receiving a signal transmitted from the other transceiver. Communications take place over a plurality of subchannels, here shown, for purposes of illustration only, as subchan-  
15 nels "9", "10", etc. in the transmitter section, and subchannels "40", "41", etc. in the receiver section. In a full-rate ADSL system, there are up to two hundred and fifty six such subchannels, each of bandwidth 4.1 kHz. For example, in one embodiment of the in-  
20 ventin, upstream communications (i.e., from the customer premises to the central telephone office) are conducted on subchannels 8 to 29; downstream communications (from the central office to the customer premises) are conducted on subchannels 32 to 255; sub-  
channels 30 and 31 form a guard band between upstream and downstream communica-  
tions that may be used for signaling as described hereinafter.

For each subchannel ("SC") 50, a field 52 defines the number of bits ("B") that are to be transmitted over that subchannel by the transmitter of a communications or modem  
25 pair, and received by the receiver of that pair, consistent with the prevailing conditions on the subchannel, e.g., measured signal-to-noise ratio (SNR), desired error rate, etc.; column 54 defines the corresponding gains ("G") of the subchannels. A first section, 42a, of the table specifies the bit allocations and gains that transceiver 34 will use in transmitting  
"upstream" to the transceiver 26; and a second section, 42b, specifies the bit allocations  
30 and gains that transceiver 34 will use in receiving transmissions from the transceiver 26. Transceiver 26 has a corresponding table 40 which is the mirror image of table 42, that is,

**SUBSTITUTE SHEET (RULE 26)**

-25-

the bit allocations specified for transmission by transceiver 34 are the same as those specified for reception by transceiver 26 and correspondingly for reception by transceiver 34 and transmission by transceiver 26. The table typically may also include a field specifying the gain 54 associated with the particular subchannel.

5           As noted above, the splitters 24, 30 combine the data and voice communications applied to them for transmission and once again separate these from each other on reception. This is accomplished by means of high pass and low pass filters which separate the low-frequency voice communications from the high-frequency data. The need to utilize such splitters, however, imposes a severe impediment to the widespread adoption of DSL  
10 technology by the consumer. In particular, the installation of a splitter at the subscriber premises requires a trip to the premises by a trained technician. This can be quite costly, and will deter many, if not most, consumers from taking advantage of this technology. Nor is incorporating splitters in the communications devices themselves a viable option, since this not only increases the cost of such devices, but requires either the purchase of  
15 all new devices or the retrofit of the older devices, which again requires skilled help to accomplish. In accordance with the present invention, we eliminate the splitter at least at the customer premises, thereby enabling adoption and use of DSL modems by the end user without the intervention of trained technical personnel. This, however, requires significant changes in the structure and operation of the DSL transceivers or modems, and  
20 the present invention addresses these changes.

In particular, figure 3 shows a DSL transmission system in accordance with the invention in which the composite voice-data signal transmitted from the central office to the subscriber premises is passed to both the subscriber voice equipment 31, 32 and to the data transceiver or modem 34' without the interposition of a splitter at the subscriber  
25 premises. In figure 3, components that are unchanged from figure 1 retain the same numbering; components that are modified are designated with a prime superscript. In place of the single table 30 of the transceiver 26 of Figure 1, the transceiver 26' of Figure 3 contains a primary channel control table 41 and a secondary channel control table 43. Similarly, transceiver 34' of Figure 3 contains a primary channel control table 45 and a  
30 secondary channel control table 47. It will also be noted that the subscriber side splitter has been eliminated in Figure 3: the reason why this can be done in the present invention

**SUBSTITUTE SHEET (RULE 26)**

-26-

will now be described in detail. It will also be noted that the central office splitter 20 in figure 1 has been retained in the configuration of Figure 3: this is optional, not mandatory. Retaining a splitter at the central office can improve the performance somewhat at little cost, since only a single installation is required and that at the central office itself where technical personnel are commonly available in any event. Where this is not the case, it may be eliminated there also.

Turning now to figure 4, the transceiver or modem 34' is shown in greater detail; the modem 26' is essentially the same for present purposes and will not be separately described. As indicated, modem 34' comprises a transmitter module 50; a receiver module 52; a control module 54; a primary channel control table 45; and a secondary channel control table 47. The primary channel control table is shown more fully in figure 5A.; the secondary channel control table is shown more fully in figure 5B.

In figure 5A, the primary channel control table 45 has a transmitter section 45a which stores a primary set of channel control parameters for use in transmitting to a remote receiver over a DSL line; and a receiver section 45b which stores a primary set of channel control parameters for use in receiving communications over a DSL line from a remote transmitter. The subchannels to which the parameters apply are shown in column 45 c. The channel control parameters in the transmitter section 45a include at least a specification of the bit allocations ("B") 45d and preferably also the gains ("G") 45e to be used on the respective subchannels during transmission. The receiver section similarly includes specification of the bit allocations and gains, and preferably also includes specification of the frequency domain equalizer coefficients ("FDQ") 45f, time domain equalizer coefficients ("TDEQ") 45g, and echo canceller coefficients ("FEC") 45h, among others.

Collectively, the parameters: bit allocation, gain, frequency domain coefficient, time domain coefficient, etc. form a parameter set, each of whose members are also sets, e.g. the bit allocation set defining the allocation of bits to each of the subchannels, the gain setting set defining the gains across the subchannels, etc. In accordance with the preferred embodiment of the present invention, the primary channel control table stores a single parameter set which has at least one member, i.e., a bit allocation set, and preferably a gain allocation set as well; this parameter set defines the default communications conditions to which the system will revert in the absence of disturbance events. The sec-

**SUBSTITUTE SHEET (RULE 26)**

-27-

ondary channel control table, however, has at least two, and typically more, parameter sets for controlling transmission and reception over the subscriber lines by the respective modems; these sets define communications under various disturbance events which change the default conditions.

5           In particular, in Figure 5B, the secondary channel control table 47 comprises a plurality of parameter sets 47a, 47b, 47c, etc., of which only three sets are shown for purposes of illustration. Each parameter set includes a transmit portion 47 d and a receive portion 47e. In each portion, one or more parameters are specified, e.g., bit allocations 47f and gains 47g in the transmit portion 47d, and frequency domain coefficients 47h, 10 time domain coefficients 47i, and echo cancellation coefficients 47j in the receive portion 47e. The actual values of the coefficients are typically complex numbers and thus they are represented simply by letters, e.g., "a", "b", etc. in the channel control tables of Figures 5A and 5B. Parameter sets 47b, 47c, and the remaining parameter sets are similarly constructed. As was the case for the primary channel control table, each parameter (e.g., 15 bit allocation) is itself a set of elements that define communication conditions, at least in part, across the subchannels to which they apply and which they help characterize.

The primary channel control table containing a bit allocation parameter set is generated in the usual manner, i.e., during initialization (typically, a period preceding the transmission of "working data" as opposed to test data), known data is transmitted to, 20 and received from, the remote modem with which the instant modem is in communication under the conditions which are to comprise the default condition for the modem. Typically, this will be with all disturbing devices inactivated, so that the highest data rate can be achieved, but the actual conditions will be selected by the user. The data received at each modem is checked against the data known to have been transmitted and the primary 25 channel control parameters such as bit allocation, subchannel gains, and the like are calculated accordingly. This table is thereafter used as long as the system remains undisturbed by disturbance events which disrupt communications over the line.

The secondary channel control table may be determined during initialization in the same manner as the primary table, but with devices that may cause disturbance events 30 actuated in order to redetermine the channel control parameters required for communications under the new conditions. These devices may be actuated one by one, and a second-

**SUBSTITUTE SHEET (RULE 26)**

-28-

5        dary parameter control set determined for each and stored in the secondary channel control table; or they may be actuated in groups of two or more, and parameter sets determined accordingly; or various combinations of single and group actuations may be performed and the corresponding parameter sets determined. Secondary parameter sets may similarly be determined from actual measurements with interfering sources such as xDSL transmissions in a common binder with the modems in question, and the resultant sets stored in the secondary table.

10        Other methods of determination of the secondary table may be employed. For example, one or more secondary parameter sets may be derived from the primary table. Thus, the bit allocation on each subchannel in the secondary table may be taken as a percentage, fixed or varying across the subchannels, of the bit allocation for each subchannel defined in the primary table. Alternatively, it may be calculated from the same data as that of the primary table, but using a larger margin; by using a percentage, fixed or varying across the subchannels, of the signal-to-noise ratio used in calculating the primary table; 15 by providing for a different bit error rate than provided for in the primary; or by other techniques, including those described earlier. Portions of the primary and secondary may be recalculated or improved upon during the communication session, and stored for subsequent use. The calculation or recalculation may be a one-time event or may occur repeatedly, including periodically, throughout a communication session.

20        Further, although use of a multiplicity of parameter sets in the secondary channel control table will generally provide the best match to the actual channel conditions and thus more nearly approach optimum communications conditions, a simplified second table containing a single composite parameter set may also be used. Thus Figure 5C shows a number of sets 49a-49d of bit allocations for the subchannels 49e and which may represent a corresponding number of different communication devices or conditions associated with communications over these subchannels. A single composite parameter set 49f may be formed as a function of the parameter sets 49a-49d by, for example, selecting, for each subchannel, the minimum bit allocation among the sets 49a-49d for each of the subchannels 49e. Such a set represents a "worst case" condition for activation of any of the devices associated with the sets 49a-49d. Other worst case parameter sets may be formed, 30 for example, on selected groups of devices, thus providing for the case when several de-

**SUBSTITUTE SHEET (RULE 26)**



vices or disturbances are operating simultaneously.

In the absence of a disturbance event, the transceivers 26', 34' use the primary channel control tables 41, 45 for communications. Responsive to detection of a disturbance event, however, the transceivers 26', 34' switch to one of the parameter sets of the secondary channel control tables 43, 47 to continue the communications under the conditions specified by the particular parameter table. These conditions may specify a diminished bit rate while maintaining the same bit error rate as is provided with the primary channel control table; or may specify the same bit rate but at a higher bit error rate; or may specify a diminished bit rate at a correspondingly diminished power level or margin; or other conditions as determined by the specific channel control tables. On termination of the disturbance condition which caused the switch, the transceivers 26', 34' return to use of the primary tables 41, 45.

Typically, the primary tables provide communications at or near the capacity of the communications channel over line 14. The secondary tables provide communications over the channel at a diminished rate. Switching between the primary and secondary tables (that is, switching from a primary parameter set to a secondary parameter set) in accordance with the present invention is fast: it can be accomplished in an interval as short as several frames (each frame being approximately 250 microseconds in current ADSL systems), and thus avoids the lengthy delay (e.g., on the order of several seconds) that would otherwise be required for determination, communication over the subscriber line, and switching of newly-determined bit allocation tables. Further, it avoids communication of such tables over the subscriber line at a time when communications have been impaired and error rates are therefore high. Thus, utilization of prestored parameter sets in accordance with the present invention minimizes disruption to the communication process occasioned by disturbance events.

The channel control tables are stored in a storage or memory for rapid access and retrieval. Preferably, the storage is a random access memory ("RAM") incorporated into the modem itself, but also comprise such a memory located in other components accessible to the modem, e.g., in a stand-alone memory; in a computer such as a personal computer ("PC"); in a disk drive; or in other elements. Further, the storage may include portions of other forms of memory, such as read only memory ("ROM").

**SUBSTITUTE SHEET (RULE 26)**

-30-

In addition to accessing the channel control tables 45 and 47, the control module 54 of Figure 4 preferably also controls formulation of the secondary control table when this table is calculated on the basis of the primary channel control table. Further, the module 54 monitors the SNR on the subscriber line 14 and calculates the primary and secondary channel control parameter sets when these sets are based on measurement of actual conditions of the line, as will most commonly be the case. To this end, the control module is advantageously implemented as a special purpose digital computer or "DSP" chip particularized to the functions described herein. It may, of course, alternatively be implemented as a general purpose computer or in other fashion, as will be understood by those skilled in the art.

In accordance with the present invention, disturbance events on the subscriber line are distinguished from transient events such as lightning impulses by mean of their consequences. In particular, a signaling event such as an off-hook signal or an on-hook signal typically causes sufficient disruption as to preclude further communications without re-initialization. The event is accompanied by an error code indication that persists throughout the disruption; a change in the amplitude and phase of the physical signal carrying the data or of a pilot tone; the application of a substantial voltage to the line; and other indicia. We monitor the subscriber line for the occurrence of one of more of these characteristics in order to detect the event.

Figure 6 illustrates one manner of detecting a disturbance event in accordance with the present invention. A detector 70, which is preferably included in control module 54, receives signals from line 14 and monitors (step 72) the error code (e.g., CRC errors or the FEC error count) associated with the signals for occurrence of an error indication. If no error is detected (step 74), the detector remains in monitoring mode without further action. If an error is indicated by the error code, a counter is incremented (step 76) and the count is then compared with a predefined threshold (step 78). If the count does not exceed the threshold (step 78, ">N?"), the system remains in monitoring mode and continues to accumulate any detected errors. If the count exceeds the threshold (step 78, Y), the detector emits a "disturbance event" detection signal (step 80) which causes the transceiver in which the detector 70 is located to initiate the process of switching to the appropriate parameter set in the secondary table. The count is reset (line 81) when this occurs.

**SUBSTITUTE SHEET (RULE 26)**

-31-

Instead of monitoring the error code for characteristic behavior (i.e., repeated error over successive frames), in accordance with the present invention one may monitor the amplitude and phase of the physical signals transmitting the data over the subchannel or of a pilot tone transmitted between modems. On the occurrence of a disturbance event, the amplitude and phase of the physical signal undergo significant change, i.e., the amplitude suddenly decreases and the phase suddenly shifts to a new value; thereafter, they maintain approximately their new values during successive frames. This behavior may be monitored as shown in Figure 7 in which a monitor 100 monitors, for example, the amplitude of a data signal or a pilot tone on line 14 and sets a flip-flop 102 to an "active" state ("Q") on detecting a change in the amplitude of greater than a predefined threshold value. Flip-flop 102 enables (input "E") a counter 104 connected to receive counting pulses from a frame counter 106 whenever a new frame is transmitted or received by the modem. These counting pulses are also applied to a threshold counter 108 which accumulates the counts applied to it until it reaches a defined count and then applies the resultant count to a comparator 110 where it is compared with the count in counter 104. If the contents of the counters 104 and 108 are equal, comparator 110 provides an output ("Y") which causes the transceiver to initiate the process of switching to the appropriate table. This also resets the counters 104, 108 and the flip-flop 102. These are also reset (input "R") if the counts of counters 104 and 108 do not match ("N" output of comparator 110).

A similar procedure may be used to generate the table-switching signal based on monitoring the phase change of data signals or pilot tones as noted above. Further, although the operation of the event detector of figure 8 has been explained largely in terms of hardware, it will be understood that it may also readily be implemented in software, or in a combination of hardware and software, as is true of most of the elements described herein.

Still a further approach to detecting a disturbance event is to monitor the disturbance event directly. For example, in the case of off-hook or on-hook signals, a 48 volt dc step voltage is applied to the subscriber line. This signal is sufficiently distinct from other signals as to be readily detectable directly simply by monitoring the line for a step voltage of this size and thereafter generating a table-switching signal in response to its

SUBSTITUTE SHEET (RULE 26)

detection. Another approach is to monitor the SNR on one or more subchannels by monitoring the "sync" frames. The presence of a disturbance from data sources on adjacent phone lines manifests itself as a change in the subchannel SNR. A direct method of monitoring disturbance events caused by activation or deactivation of communication-

5     disturbing devices is to directly signal between the device and the local modem on occurrence of either of these events. As shown in Figure 3, for example, signaling lines 35, 37 may be extended directly between the local modem 34' and its associated devices 31, 32 to directly signal a change in these devices, such as their activation ("off hook") or deactivation ("on hook").

10             In addition to changing the control tables in response to a disturbance event, it is desirable to decrease the upstream transmit power level in order to minimize the interference with the voice communications caused by upstream transmissions, as well as to reduce the leakage of these transmissions into the downstream signal ("echo"). These interferences arise from nonlinearities caused by devices such as telephones that are coupled to

15     the line, especially when the telephones are off-hook. The amount of power reduction required to render the interferences acceptable varies from one telephone to the next. In the preferred embodiment of the invention, a probing signal is used to determine the required decrease in upstream transmit power. In particular, after detecting a disturbance event such as activation or deactivation of a telephone or interference from other sources

20     which can disrupt communications, the transmitter portion of the ATU-R (the "upstream transmitter") transmits a test signal over the subscriber line at varying power levels and measures the echo at the receiver portion of the ATU-R (the "downstream receiver"). The resultant measurement is used to determine an upstream transmission power level that minimizes echo at the downstream receiver or that at least renders it acceptable. The

25     new power level, of course, is typically associated with a corresponding new parameter set in the channel control parameters.

           In addition to changing the bit allocation and gain parameters in response to a disturbance event, it is generally necessary to change one or both of the subchannel equalizers, (i.e., the time-domain equalizers or the frequency-domain equalizers), as well

30     as the echo canceller. Appropriate sets of these parameters may be formed in advance in the same manner as the bit allocations and channel gains (i.e., in a preliminary training

-33-

session, sending test communications over the subscriber line with various devices connected to the line activated, measuring the resultant communication conditions, and determining the various parameters based on the measurements), and stored in the secondary channel control table for recall and use as required. Alternatively, they may be re-  
5 terminated quickly during a retraining operation following detection of a disturbance event and without excessively disrupting communications, since these parameters are local to the receiver and thus need not be transmitted to the other modem in the communications pair.

In particular, in accordance with the preferred embodiment of the invention, on  
10 detecting a disturbance event, the transceivers enter a "fast retrain" phase, as shown in more detail in Figure 8. A common disturbance event is taking a telephone off hook or replacing it on hook, and this is commonly detected at the ATU-R. The fast retrain process will be illustrated for such an event, although it will be understood that it is not limited to this, and that the retrain may be initiated for any type of disturbance event, and at either  
15 end of the communication. Thus, on detecting such an event (Figure 8, event 200), the ATU-R notifies the ATU-C (step 202) to enter the fast retrain mode. The notification is preferably performed by transmitting a specific tone to the ATU-C, but may also comprise a message or other form of communication. On receiving this notification (step 204), the ATU-C awaits notification from the ATU-R of the power levels to be used for subsequent  
20 communications. This includes at least the upstream power level, and may include the downstream power level as well, since changing the upstream power level may impact downstream communications to some extent. For purposes of completeness, it will be assumed that both of these power levels are to be changed, although it will be understood that in many cases, only the upstream power level will be changed.

25 The new power levels to be used are determined by the ATU-R (step 208), which transmits a channel-probing test signal to the upstream transceiver and measures the resultant echo at the downstream receiver; it then sets the upstream power level to minimize the echo into the downstream signal, and may also set the downstream power level to minimize the effects of leakage of the upstream transmission into the downstream trans-  
30 mission at the upstream transmitter. The ATU-R then communicates (steps 210, 212) to the ATU-C the selected upstream and downstream transmission levels, e.g., by transmit-

SUBSTITUTE SHEET (RULE 26)

ting to the upstream transceiver one or more tones modulated by binary PSK (phase shift  
keying) signals to ensure robust communication of the power levels. The power levels  
may be specified directly (e.g., as “-30dbm”), or indirectly (e.g., as “level 3” of a prede-  
fined group of levels), and the specification may identify the actual value of the power  
5 level, or simply the change in power level to be effectuated.

The ATU-R (step 214) and ATU-C (step 216) next commence transmission at the  
new power levels for purposes of retraining the equalizers and echo cancellers. Prefera-  
bly, the change to the new power levels is synchronized through use of frame counters  
which are used in DSL systems to align transmitters and receivers, but the synchronization  
10 may be accomplished by other means (e.g., by transmitting a tone or message or by simply  
sending a flag) or may be left unsynchronized. Based on the training transmission, the  
ATU-R and ATU-C determine (steps 218, 220) the time and frequency domain equalizer  
parameters appropriate to the new power levels, as well as the appropriate echo canceller  
coefficients. The determination may include calculations based on these measurements in  
15 order to determine the coefficients, or the measurements may be used to select a particu-  
lar set or sets of coefficients from one or more precalculated sets stored at the ATU-R  
and ATU-C, respectively.

For example, as was the case with determination of the power levels responsive to  
a disturbance event, the SNRs on various subchannels may be used to identify a particular  
20 device or devices associated with the event and thus to select an appropriate prestored  
parameter set stored at the ATU-R and ATU-C, respectively, simply by transmitting to  
the other modem in the communication pair a message or tone set that specifies the num-  
ber of the parameter set to be used for subsequent communications. The SNR measure-  
ments thus serve as a “signature” of the device or devices associated with the disturbance  
25 event, and allow rapid identification of these devices. This approach can significantly re-  
duce the time required to retrain the equalizers and echo cancellers. And even if training  
is required under particular circumstances, the training time can be meaningfully reduced  
by using prestored coefficients as the starting point.

To facilitate use of the SNR measurements in retrieving corresponding parameter  
30 sets, it is desirable that the various parameter sets as stored be indexed to sets of SNRs,  
so that one or more parameter sets associated with particular communication conditions

**SUBSTITUTE SHEET (RULE 26)**

-35-

may quickly be identified and retrieved. One way in which this may be accomplished is shown in Fig. 9A in which the respective parameter sets such as a first set 250, a second set 252, etc. have, in addition to the subchannel (SC) number 254 and the corresponding bit allocation (BA) and gain (G) entries, a SNR entry 260 characteristic of the parameter set appropriate to a given communication condition, such as "on-hook" (table 250), "off-hook" (table 252), etc. Additional parameter sets such as frequency domain equalizer coefficients, time domain equalizer coefficients, and echo cancellation coefficients may also be stored in the tables, as would be appropriate for the receiver portion of the modem; for the transmitter portion, these coefficients are not applicable and thus are not stored.

An alternative means of linking the subchannel SNRs and the corresponding parameter sets is shown in Figure 9B. As there shown, a simple list structure 270 comprises a parameter set identifier 272, and a multiplicity of SNR measures 274, 276, etc. SNRs for some or all of the subchannels may be included. The list may be searched measure for measure to identify the nearest match to a stored parameter set, and that set then retrieved for subsequent use. In either Figure 9A or 9B the parameter set indexed to the SNRs may be a set of multiple parameters, such as bit allocations and gains, among others, of may comprise a single set such bit allocations only, or gains, only, etc.

The identification of the channel control parameter sets to be used for the subsequent communications is exchanged between the transceivers (steps 226-232) which then switch to these parameter sets (234, 236) and commence communications under the new conditions. The message containing the channel control parameters is preferably modulated in a similar manner as the "power level" message, i.e., using several modulating tones with BPSK signaling. The message is therefore short and very robust. It is important that it be short so that the fast retrain time is minimized, since the modem is not transmitting or receiving data during this time and its temporary unavailability may thus be very noticeable, as would be the case, for example, when the modem is being used for video transmission, or internet access, etc. Similarly, it is important that the message transmission be robust, since error-free communication during a disturbance event is very difficult, due to decreased SNR, impulse noise from ringing or dialing, or the like. Thus, the provision and utilization of pre-stored parameter sets significantly enhances the reli-

**SUBSTITUTE SHEET (RULE 26)**

ability of communications despite the absence of a splitter at at least one of the modems and despite the presence of disturbance events concurrent with data communications.

It is expected that the modems described herein will most commonly be used in dedicated pairs, i.e., each subscriber (ATU-R) modem will communicate with a dedicated  
5 central office (ATU-C) modem. However, in certain cases it may suffice to provide a single master central office modem to service two or more subscriber modems. The present invention accommodates that eventuality as well. Thus, in Figure 10, a central office modem 280 communicates through a switch 282 with a plurality of subscriber modems 284, 286, 288 over subscriber lines 290, 292, 294. The modems may be located at differ-  
10 ing distances from the central office and in different communication environments, and thus the channel control tables of each may be unique among themselves. Accordingly, the central office modem stores a master set 296 of individual channel control parameter sets 298, 300, 302, etc., one set (both transmit and receive) for each subscriber modem. On initiating communications to a particular subscriber, the central office modem retrieves  
15 the appropriate transmission parameter set for the subscriber and uses it in the subsequent communications. Similarly, on initiating communications to the central office, a given subscriber modem identifies itself to enable the central office modem to retrieve the appropriate reception parameter set for that subscriber.

### CONCLUSION

20 From the foregoing it will be seen that we have provided an improved communications system for communication over subchannels of limited bandwidth such as ordinary residential telephone lines. The system accommodates both voice and data communications over the lines simultaneously, and eliminates the need for the installation and use of “splitters”, an expense that might otherwise inhibit the adoption and use of the high com-  
25 munication capacity offered by DSL systems. Thus, it may be implemented and used as widely as conventional modems are today, but offers significantly greater bandwidth than is currently attainable with such modems.



## CLAIMS

- 1 1. Apparatus for use in connection with a wireline data communication system carrying  
2 data in a multiplicity of different frequency bands which may be present concurrently on  
3 the line, comprising
- 4       A. means for detecting a signaling event associated with at least a first of said  
5 bands;
- 6       B. means responsive to said detecting means for modifying the processing of sig-  
7 nals transmitted over at least a second of said bands.
- 1 2. Apparatus for use in connection with a wireline data communication system carrying  
2 data in a multiplicity of different frequency bands which may be present concurrently on  
3 the line and including means responsive to a signal resulting from a disturbance event to  
4 modify the transmission of data over said line.
- 1 3. Apparatus according to claim 2 in which said signal is a collection of PSK modulated  
2 tones.
- 1 4. Apparatus according to claim 2 in which said disturbance event is an on-hook to off-  
2 hook transition.
- 1 5. Apparatus according to claim 2 in which said disturbance event is off-hook to on-hook  
2 transition
- 1 6. Apparatus according to claim 2 in which said disturbance event is caused by a change  
2 in the crosstalk environment.
- 1 7. Apparatus according to claim 2 in which said modification of transmission includes  
2 sending a sequence of reference frames.
- 1 8. Apparatus according to claim 2 in which said modification of transmission includes en-  
2 tering a fast retrain mode.

SUBSTITUTE SHEET (RULE 26)

- 1 9. Apparatus according to claim 1 in which said detecting means comprises
- 2 (1) means for measuring, at a multiplicity of different times, a characteristic of
- 3 a signal transmitted over said wireline
- 4 (2) means for activating said modifying means when samples of the measured
- 5 characteristics differ in a defined manner at selected different times.
- 1 10. Apparatus according to claim 9 in which said measuring means measures the extent
- 2 of errors in error-correcting code associated with the signals whose processing is to be
- 3 modified and activates said modifying means only when the extent of said errors exceeds a
- 4 defined threshold for at least a defined number of times.
- 1 11. Apparatus according to claim 10 in which said measuring means activates said modi-
- 2 fying means only when the number of errors in each said sample exceeds a defined number
- 3 in each of two or more samples.
- 1 12. Apparatus according to claim 9 in which said measuring means measures a character-
- 2 istic of signals transmitted over a plurality of different frequency bands and activates said
- 3 modifying means only when the measured characteristic exceeds defined thresholds asso-
- 4 ciated with each of said plurality of frequency bands.
- 1 13. Apparatus according to claim 1 in which said wireline data communication system
- 2 comprises a telephone subscriber loop carrying both voice and data signals, and in which
- 3 said signaling event comprises an off-hook event.
- 1 14. Apparatus according to claim 1 in which said wireline data communication system
- 2 comprises a telephone subscriber loop carrying both voice and data signals, and in which
- 3 said signaling event comprises an on-hook event.
- 1 15. Apparatus according to claim 14 which includes a frequency domain equalizer for
- 2 equalizing the frequency characteristics of each of said frequency bands in accordance
- 3 with reference signals transmitted over said bands and in which said modifying means
- 4 comprises means for changing the characteristics of said equalizers in accordance with

5 measurements on said reference signals.

1 16. Apparatus according to claim 9 in which said measuring means measures the signal-  
2 to-noise ratio of said reference signals and activates said modifying means only when said  
3 ratio is less than a defined threshold for at least a defined number of times

1 17. Apparatus according to claim 9 in which said data communication system includes  
2 means for transmitting a pilot tone and in which said apparatus includes means for meas-  
3 uring at least one characteristic of said tone at different times and means for activating  
4 said modifying means only when said characteristics manifest changes exceeding a defined  
5 threshold for at least a defined number of times.

1 18. Apparatus according to claim 9 which includes means for transmitting over said  
2 wireline information back to a source of said information signals, said means transmitting  
3 at a first power level in the absence of detection of a signaling event, and transmitting at a  
4 different power level responsive to detection of a signaling event.

1 19. Apparatus according to claim 9 which includes a first set of stored parameters for use  
2 in processing said information when said system is in a first state.

1 20. Apparatus according to claim 19 which further includes a second set of stored pa-  
2 rameters for processing said information when said system switches to a second state re-  
3 sponsive to detecting a signaling event.

1 21. Apparatus according to claim 20 in which said second set is precomputed.

1 22. Apparatus according to claim 21 in which said second set is computed responsive to  
2 reference signals received on said subchannel subsequent to detection of a signaling event.

1 23. Apparatus according to claim 21 in which said first and second sets are computed on  
2 initiating a communications session.

1 24. Apparatus according to claim 1 including means for varying the data rate at which  
2 said modifying means processes said signals.

1 25. In a modem communicating data over a multiplicity of discrete sub-subchannels, each

-40-

2 characterized by a bit allocation parameter defining the allocation of bits to the corre-  
3 sponding subchannel for communication over said subchannel, the improvement compris-  
4 ing:

5 A. means for storing a first channel control table for allocating bits to said  
6 subchannel during a first communication condition;

7 B. means defining a second channel control table for allocating bits to said  
8 table during a second communication condition;

1 26. A modem according to claim 25 which includes a

2 means for switching between said tables on the detection of a defined event.

1 27. A modem according to claim 25 in which said first table establishes the communica-  
2 tions capabilities of said modem during normal operation.

1 28. A modem according to claim 27 in which said second table establishes the communi-  
2 cations capabilities of said modem during diminished operation.

1 29. A modem according to claim 25 in which said defined event includes signaling events  
2 comprising transitions between on-hook and off-hook conditions.

1 30. A modem according to claim 29 in which said first table defines communications in  
2 the absence of a signaling event.

1 31. A modem according to claim 30 in which said second table defines communications  
2 responsive to detection of a signaling event.

1 32. A modem according to claim 31 in which said switching means switches from said  
2 second table to said first table on detection of a signaling event indicative of cessation of a  
3 previously-detected signaling event.

1 33. A modem according to claim 25 in which said first and second tables are determined  
2 during an initialization session in which the communication capabilities of said sub-  
3 subchannels are determined.

**SUBSTITUTE SHEET (RULE 26)**

1 34. A modem according to claim 33 in which said first table is determined in the absence  
2 of interfering signaling conditions.

1 35. A modem according to claim 34 in which said second table is determined as a func-  
2 tion of said first table.

1 36. A modem according to claim 35 in which the bit allocations of said second table are  
2 determined as a percentage of the bit allocations of said first table.

1 37. A modem according to claim 27 in which the bit allocations of second table are de-  
2 termined by adding noise margins to the determination of the bit allocations of the corre-  
3 sponding sub-subchannels of said first table.

1 38. A modem according to claim 25 in which said second channel control table is deter-  
2 mined responsive to a plurality of signaling events created by a corresponding plurality of  
3 event-generating sources, each defining a channel control table specific to the given  
4 source, and comprises a composite table formed by selecting, for each sub-subchannel, the  
5 minimum bit allocation for the corresponding sub-subchannel of the table associated with  
6 each of the plurality of sources.

1 39. A modem according to claim 25 in which said second channel control table is selected  
2 from a plurality of tables determined responsive to a plurality of signaling events created  
3 by a corresponding plurality of event-generating sources, each defining a channel control  
4 table specific to the given source.

1 40. A modem according to claim 39 which includes means for selecting one of said plu-  
2 rality of tables for use as said second table in accordance with the source generating an  
3 event.

1 41. A modem according to claim 25 which further includes:

2 C. means for redetermining said channel control tables while said modem is in  
3 either of said communication conditions; and

4 D. means for communicating a redetermined table to a second modem en-

**SUBSTITUTE SHEET (RULE 26)**

5 gaged in communication with said modem.

1 42. A modem according to claim 41 in which said communicating means communicates  
2 said redetermined table over a dedicated sub-subchannel selected from among said dis-  
3 crete sub-subchannels.

1 43. A modem according to claim 41 in which said communicating means further com-  
2 municates to said second modem information identifying the type of said redetermined  
3 table.

1 44. A modem for use in asymmetric digital subscriber loop communications having both  
2 upstream and downstream communication subchannels formed from a plurality of sub-  
3 subchannels, said loop adapted to carry both voice and data communications thereon,  
4 comprising:

5 A. means for storing a first table defining data communications between said  
6 modem and a second modem connected to said loop during a first communication state;

7 B. means for storing a second table defining data communications between  
8 said modem and said second modem during a second communication state.

1 45. A modem according to claim 44 that includes means for switching between said tables  
2 responsive to the occurrence of selected events.

1 46. A modem for use in asymmetric digital subscriber loop communications having both  
2 upstream and downstream communication subchannels formed from a plurality of sub-  
3 subchannels, said loop adapted to carry both voice and data communications thereon,  
4 comprising:

5 A. means for storing a first table defining data communications between said  
6 modem and a second modem connected to said loop during a first communication state;

7 B. means for storing a second table defining data communications between  
8 said modem and said second modem during a second communication state; and

9 C. means for selecting between said tables based on signals received from

10 said second modem.

1 47. A modem according to claim 44 which includes:

2 D. means for detecting said selected events, said means including

3 (1) means for monitoring a selected characteristic of at least one of  
4 said communication subchannels during a plurality of communication intervals;

5 (2) means for determining differences in the selected characteristic  
6 over said plurality of intervals;

7 (3) means for generating a signal initiating switching of said tables  
8 when said differences exhibit a defined pattern.

1 48. A modem according to claim 47 in which said pattern comprises an initial difference  
2 above a first threshold amount followed by at least a subsequent differences less than a  
3 second threshold amount.

1 49. A modem according to claim 48 in which said first threshold is greater than said sec-  
2 ond threshold.

1 50. A modem according to claim 49 in which said pattern comprises an initial difference  
2 above a first threshold amount followed by a plurality of subsequent differences less than  
3 a second threshold amount.

1 51. A modem according to claim 48 in which said selected characteristic is monitored  
2 over at least one sub-subchannel.

1 52. A modem according to claim 48 in which said selected characteristic is monitored  
2 over a plurality of sub-subchannels.

1 53. A modem according to claim 52 which includes means for averaging the monitored  
2 values of said selected characteristic over said sub-subchannels for use in comparing said  
3 initial difference to said first threshold.

1 54. A modem according to claim 52 which includes means for averaging the monitored

**SUBSTITUTE SHEET (RULE 26)**

-44-

2 values of said selected characteristic over said sub-subchannels for use in comparing said  
3 subsequent difference to said second threshold.

1 55. A modem according to claim 49 in which said characteristic comprises an error code  
2 error.

1 56. A modem according to claim 49 in which said characteristic comprises a signal-to-  
2 noise ratio.

1 57. A modem according to claim in which said characteristic comprises a parameter of a  
2 pilot tone.

1 58. A modem according to claim 44 in which said first table establishes a data rate  
2 greater than that of said second table.

1 59. A modem according to claim 58 in which said tables define the number of bits  
2 transmitted over the respective sub-subchannels.

1 60. A modem according to claim 59 in which said events comprise signaling events se-  
2 lected from the group comprising off-hook, on-hook, ringing, and busy.

1 61. A modem according to claim 47 in which said switching means returns said modem  
2 to said first communication state on termination of the event causing the switching.

1 62. A modem according to claim 44 which includes:

2 D. means for emitting into said loop a test signal for probing the return char-  
3 acteristics of transmissions into the loop by said modem; and

4 E. means for limiting the power level of said transmissions in accordance with  
5 the measured return characteristics.

1 63. A modem according to claim 62 in which said probe comprises a tone at a defined  
2 amplitude and frequency and in which the measured return characteristics comprise at  
3 least one characteristic selected from the group comprising the amplitude and frequency  
4 of the signal returned to said modem in response to emission of said tone.

**SUBSTITUTE SHEET (RULE 26)**



1 64. A modem according to claim 62 in which said probe comprises a plurality of tones at  
2 defined amplitudes and frequencies and in which the measured return characteristics com-  
3 prise at least one characteristic selected from the group comprising the amplitudes and  
4 frequencies of the signal returned to said modem in response to emission of said tone.

1 65. A modem according to claim 44 which includes equalizers for equalizing the trans-  
2 mission characteristics of said subchannels and in which said tables define;

3 (1) coefficients of time domain equalizers or

4 (2) coefficients of frequency domain equalizers or

5 (3) coefficients of digital echo cancellers

1 66. A modem according to claim 44 in which said first table is determined during an ini-  
2 tialization process in the absence of a selected event.

1 67. A modem according to claim 66 in which said second table is determined during an  
2 initialization process in the presence of a selected event.

1 68. A modem according to claim 67 in which said second table is redetermined respon-  
2 sive to occurrence of a selected event.

1 69. A modem according to claim 68 in which redetermined tables are communicated from  
2 a given modem to other modems with which it is in communication during a quiescent  
3 state.

1 70. A modem according to claim 47 in which said generating means causes transmission  
2 of a switch-control signal over one of said sub-subchannels in response to detection of a  
3 selected event.

1 71. A modem according to claim 47 in which said generating means causes transmission  
2 of a tone in response to detection of a selected event.

1 72. Apparatus for use in communicating digital data over a digital subscriber line concu-  
2 rent with voice communications over said line, comprising:

**SUBSTITUTE SHEET (RULE 26)**

-46-

- 3           A. a transceiver for communicating digital data to and from said line;
- 4           B. a first storage element for storing a first set of communication parameters for  
5 use in communicating data under a first communication condition; and
- 6           C. a second storage element for storing a second set of communication parame-  
7 ters for use in communicating data under a second communication condition.
- 1   73. Apparatus according to claim 72 including a means for monitoring communication  
2 conditions on said line and for switching between said first and second sets of communi-  
3 cation parameters responsive to changes between said communication conditions.
- 1   74. Apparatus according to claim 72 including means responsive to signals communi-  
2 cated to it to switch between said sets of communicaton parameters.
- 1   75. Apparatus according to claim 72 which communicates said data over a plurality of  
2 subchannels of different frequency and at least potentially different information-carrying  
3 capacity and in which said communication parameters comprise at least a channel control  
4 table defining the number of bits to be allocated to the subchannels for communications  
5 under the respective conditions.
- 1   76. Apparatus according to claim 72 which communicates said data over a plurality of  
2 subchannels of different frequency and at least potentially different information-carrying  
3 capacity and in which said communication parameters comprise subchannel gain tables  
4 defining the gain characteristics of the subchannels for communications under the respec-  
5 tive conditions.
- 1   77. Apparatus according to claim 72 which communicates said data over a plurality of  
2 subchannels of different frequency and at least potentially different information-carrying  
3 capacity and in which said communication parameters comprise frequency domain equal-  
4 izers defining the frequency characteristics of the subchannels for communications under  
5 the respective conditions.
- 1   78. Apparatus according to claim 72 in which both sets of communication parameters are  
2 determined during an initialization interval preceding communication of working data.

SUBSTITUTE SHEET (RULE 26)

- 1 79. Apparatus according to claim 72 in which said first set of communication parameters  
2 is determined during an initialization interval preceding communication of working data  
3 and said second set of parameters is determined during a subsequent interval following  
4 communication of working data and characterized by said second communications condi-  
5 tions.
- 1 80. Apparatus according to claim 79 in which said second set of communication parame-  
2 ters is determined at a first transceiver of a transceiver pair in communication with each  
3 other and is communicated to a second transceiver in said pair during a time when said  
4 transceivers are operating with an earlier set of set of secondary parameters.
- 1 81. Apparatus according to claim 80 in which said transceivers revert to said first set of  
2 communications parameters responsive to return of communications to a first communi-  
3 cations condition.
- 1 82. Apparatus according to claim 72 which includes means for signaling between said  
2 transceivers a desired change in communications parameters.
- 1 83. Apparatus according to claim 82 in which said signaling means comprises means for  
2 transmitting messages over one or more subchannels.
- 1 84. Apparatus according to claim 82 in which said signaling means comprises means for  
2 transmitting messages over one or more subchannels intermediate subchannels used for  
3 upstream and downstream communications.
- 1 85. Apparatus according to claim 83 in which said messages comprise tones.
- 1 86. Apparatus according to claim 72 in which said transceiver transmits and receives data  
2 over a defined number of subchannels and which includes means for identifying the sub-  
3 channels over which said transceivers will communicate with each other.
- 1 87. Apparatus according to claim 86 in which said identifying means includes means for  
2 nulling at least those portions of the stored sets of communications parameters that define  
3 the bit capacity of the subchannels that are being excluded from communications.

- 1 88. Apparatus according to claim 72 in which said second set of parameters includes  
2 communication parameters corresponding to a plurality of devices connected for voice  
3 communications over said line.
- 1 89. Apparatus according to claim 80 in which said second set of parameters includes a  
2 plurality of subsets of communications parameters characteristic of a corresponding plu-  
3 rality of voice communication devices for defining communications when a selected de-  
4 vice is active.
- 1 90. Apparatus according to claim 89 including means for identifying which of said plural-  
2 ity of devices is active and for selecting the corresponding communications parameter set  
3 for such device.
- 1 91. Apparatus according to claim 90 in which said identifying means includes signaling  
2 means interconnecting said voice communication devices to said transceiver.
- 1 92. In a communication system using discrete multitone modulation, the improvement  
2 comprising storing a first channel control table for use in defining communications under  
3 a first communication state and storing at least a second channel control table for com-  
4 munication under a second communication state.
- 1 93. A modem for use in symmetric or asymmetric digital subscriber loop communica-  
2 tions having both upstream and downstream communication subchannels formed from a  
3 plurality of sub-subchannels, comprising:
- 1       A. means for storing a first table defining data communications between said  
2 modem and a second modem connected to said loop during a first communication state;
- 3       B. means for storing a second table defining data communications between  
4 said modem and said second modem during a second communication state:
- 1 94. A modem according to claim 93 that includes means for switching between said ta-  
2 bles responsive to the occurrence of selected events.
- 1 95. A modem according to claim 94 in which said selected event includes a transition

2 from on-hook to off-hook.

1 96. A modem according to claim 94 in which said selected event includes a transition  
2 from off-hook to on-hook.

1 97. A modem according to claim 94 in which said selected event includes a change in the  
2 crosstalk environment.

1 98. A modem according to claim 93 that includes means for switching between said ta-  
2 bles based upon reception of a signal from a remote modem.

1 99. A modem according to claim 98 in which said signal includes a message.

1 100. A modem according to claim 98 in which said signal includes a tone or set of tones.

1 101. A modem according to claim 98 in which said signal includes a flag.

1 102. A modem according to claim 93 that includes means for switching between said ta-  
2 bles at a time that depends upon a frame counter.

1 103. A modem according to claim 93 that includes means for switching between said ta-  
2 bles at a time that depends upon a flag.

1 104. A multicarrier modem for use in symmetric or asymmetric digital subscriber loop  
2 communications having both upstream and downstream communication subchannels  
3 formed from a plurality of subchannels that includes a means to select the number of said  
4 subchannels that are to be used for communications based upon a signal from a remote  
5 modem.

1 105. A modem according to claim 104 in which said signal is received prior to initializa-  
2 tion of modem.

1 106. A modem according to claim 104 in which said signal is a message dictating how  
2 many subchannels are to be used.

1 107. A modem according to claim 104 in which said signal is a message selecting one of  
2 a collection of candidate subchannel selections.

**SUBSTITUTE SHEET (RULE 26)**

-50-

1 108. A modem according to claim 104 in which said signal is a tone or collection of tones  
2 selecting one of a collection of candidate subchannel selections.

1 109. A multicarrier modem for use in symmetric or asymmetric digital subscriber loop  
2 communications having both upstream and downstream communication subchannels  
3 formed from a plurality of subchannels that includes a means to signal to a remote modem  
4 the number of said subchannels that are to be used for communications.

1 110. A modem according to claim 109 in which said signal is transmitted prior to initiali-  
2 zation of modem.

1 111. A modem according to claim 109 in which said signal is a message dictating how  
2 many subchannels are to be used.

1 112. A modem according to claim 109 in which said signal is a message selecting one of  
2 a collection of candidate subchannel selections.

1 113. A modem according to claim 109 in which said signal is a tone or collection of tones  
2 selecting one of a collection of candidate subchannel selections.

1 114. A multicarrier modem for use in symmetric or asymmetric digital subscriber loop  
2 communications having both upstream and downstream communication subchannels  
3 formed from a plurality of subchannels, comprising of a means to limit the number of  
4 transmission subchannels in order to communicate with a remote modem that is only ca-  
5 pable of receiving the limited frequency band.

1 115. A multicarrier modem for use in symmetric or asymmetric digital subscriber loop  
2 communications having both upstream and downstream communication subchannels  
3 formed from a plurality of subchannels, comprising of a means to limit the number of re-  
4 ceiver subchannels in order to communicate with a remote modem that is only capable of  
5 transmitting the limited frequency band.

1 116. A multicarrier modem that for use in symmetric or asymmetric digital subscriber  
2 loop communications having both upstream and downstream communication subchannels

**SUBSTITUTE SHEET (RULE 26)**

-51-

3 formed from a plurality of subchannels, comprising of a means to determine the location  
4 of a telephone that would benefit from the use of a low pass filter.

1 117. A multicarrier modem according to claim 116 in which said determination means  
2 includes monitoring the signal to noise ratio when said telephone goes off-hook.

1 118. A multicarrier modem according to claim 116 in which said determination means  
2 includes monitoring the echo response of the transmitted signal when said telephone goes  
3 off-hook.

1 119. In a modem communicating data over a wireline via a multiplicity of discrete sub-  
2 channels in accordance with a bit-loading specification defining the allocation of bits to  
3 the corresponding subchannel for communication thereon, the improvement comprising:

4           A. first means for storing a primary bit allocation table for allocating said bits during  
5 a first communication condition; and

6           B. second means for storing a secondary bit allocation table for allocating said  
7 bits during a second communication condition.

1 120. A modem according to claim 119 which includes means for switching between bit  
2 allocation sets defined by said tables.

1 121. A modem according to claim 120 in which said switching means is actuated respon-  
2 sive to at least one of the events comprising receipt of a message, a tone, or a flag from a  
3 remote modem.

1 122. A modem according to claim 121 in which switching means includes the use of a  
2 frame counter to designate when said switch is to occur.

1 123. A modem according to claim 119 in which said primary bit allocation table defines  
2 communications in the absence of a disturbance event, and in which said secondary bit  
3 allocation table defines communications in response to said disturbance event.

1 124. A modem according to claim 123 in which said secondary bit allocation table defines  
2 communications over said subchannels for times when said subchannels are affected by

**SUBSTITUTE SHEET (RULE 26)**

3 voice communication activities.

1 125. A modem according to claim 124 in which said secondary bit allocation table defines  
2 communications over said subchannels for times when said subchannels are affected by  
3 voice communication devices that have entered the off-hook state.

1 126. A modem according to claim 124 in which said primary bit allocation table defines  
2 communications over said subchannels for times when said subchannels are affected by  
3 voice communication devices that have returned from an off-hook state.

1 127. A modem according to claim 119 in which said primary table is determined in a pre-  
2 liminary training session in which potentially interfering voice communication devices  
3 connected to the line are inactive.

1 128. A modem according to claim 119 in which said primary table is determined in the  
2 absence of disturbance events.

1 129. A modem according to claim 119 in which said primary bit allocation table is de-  
2 termined in advance of installation of said modem.

1 130. A modem according to claim 119 in which said secondary table is determined in an  
2 initial training session based on measurements of communications over said wireline.

1 131. A modem according to claim 119 in which said secondary table is determined in ini-  
2 tial training sessions based on measurements of communications over said wireline with  
3 potentially interfering voice communication devices connected to the line selectively acti-  
4 vated to thereby form a secondary table comprising a plurality of bit allocation sets corre-  
5 sponding to the plurality of activated devices.

1 132. A modem according to claim 131 in which said devices are activated one by one so  
2 that each bit allocation set corresponds to a single device.

1 133. A modem according to claim 131 in which said devices are activated in groups of  
2 two or more so that each bit allocation set corresponds to one of said groups.

1 134. A modem according to claim 119 in which said secondary bit allocation table is de-



2 terminated from said primary bit allocation table.

1 135. A modem according to claim 119 in which the bit allocations of said secondary table  
2 are determined as a percentage of the bit allocations of said primary table.

1 136. A modem according to claim 119 in which the bit allocations of said secondary table  
2 are determined based on a percentage of the signal to noise ratios on which the bit alloca-  
3 tions of said primary table are determined.

1 137. A modem according to claim 119 in which the bit allocations of said secondary table  
2 are determined based on information defining said primary table but using a different bit  
3 error rate

1 138. A modem according to claim 119 in which said secondary bit allocation table is  
2 formed as a composite of the bit loading sets of a multiplicity of voice communication  
3 devices and/or disturbances.

1 139 A modem according to claim 119 in which the bit allocation value for each subchan-  
2 nel in said composite is the worst-case value for the corresponding subchannel in the bit  
3 allocation sets defining said devices and/or disturbances.

1 140. A modem according to claim 119 in which said secondary bit allocation table is de-  
2 termined by adding a power margin to the calculations for the respective entries of the  
3 primary table.

1 141. A modem according to claim 119 in which said secondary table comprises a set of  
2 bit allocation tables defining the bit allocations for a corresponding set of devices that may  
3 be connected to said wireline.

1 142. A modem according to claim 119 in which said secondary table comprises a set of  
2 bit allocation tables defining the bit allocations for a corresponding set of disturbances on  
3 said wireline.

1 143. A modem according to claim 119 in which said secondary table comprises a set of  
2 bit allocation tables defining the bit allocations for a corresponding set of devices and

3     disturbances on said wireline.

1     144. A modem according to claim 119 in which a plurality of secondary bit allocation  
2     tables are determined by adding a corresponding plurality of power margins to the calcu-  
3     lations for the respective entries of the primary table, each secondary table so determined  
4     corresponding to a different communications state.

1     145. A modem according to claim 119 in which said power margin is substantially uni-  
2     form across the entries of a table.

1     146. A modem according to claim 119 in which said power margin varies across the en-  
2     tries of a table.

1     147. A modem according to claim 119 configured to switch to a secondary state corre-  
2     sponding to use of said secondary bit allocation table for communications responsive to  
3     occurrence of a disturbance event.

1     148. A modem according to claim 147 configured to switch to a primary state corre-  
2     sponding to use of said primary bit allocation table for communications responsive to ces-  
3     sation of a disturbance event.

1     149. A modem according to claim 147 configured to switch to a different secondary state  
2     corresponding to use of a different set of bit allocations in said secondary bit allocation  
3     table for communications responsive to occurrence of a further disturbance event, differ-  
4     ent from a disturbance event preceding it, while said modem is in said secondary state.

1     150. A modem according to claim 119 in which said switching means includes means re-  
2     sponsive to a disturbance event to thereby initiate a switch between said tables.

1     151. A modem according to claim 150 which includes a signaling line connecting a de-  
2     vice to said modem for signaling to said modem the occurrence of a disturbance event.

1     152. A modem according to claim 150 which includes means for detecting a disturbance  
2     event on said line.

1     153. A modem according to claim 152 in which said detecting means includes means for

2 monitoring the signal to noise ratios on one or more subchannels of said line and means  
3 responsive to said ratios for selecting a bit allocation set for use in communications.

1 154. A modem according to claim 152 in which said detecting means includes means for  
2 monitoring a parameter of a tone or collection of tones and means responsive to said pa-  
3 rameter for selecting a bit allocation set for use in communications.

1 155. A modem according to claim 152 in which said parameter includes the amplitude  
2 and/or phase of said tone or tones.

1 156. In a modem communicating data over a wireline via a multiplicity of discrete sub-  
2 channels in accordance with a gain specification defining the allocation of gains to the cor-  
3 responding subchannel for communication thereon, the improvement comprising:

4 A. first means for storing a primary gain set for allocating said gains during a first  
5 communication condition; and

6 B. second means for storing a secondary gain set for allocating said gains during a  
7 second communication condition.

1 157. A modem according to claim 156 which includes means for switching between said  
2 gain sets.

1 158. A modem according to claim 157 in which said switching means is actuated respon-  
2 sive to at least one of the events comprising receipt of a message, a tone, or a flag from a  
3 remote modem.

1 159. A modem according to claim 157 in which said switching means is actuated respon-  
2 sive to its detection of a disturbance event.

1 160. A discrete multitone modem including a transmitter for communicating to a remote  
2 receiver at one of a plurality of power levels associated with particular communication  
3 conditions on a digital subscriber line, comprising

4 A. means for monitoring at least one parameter indicative of communication  
5 conditions on said line;

**SUBSTITUTE SHEET (RULE 26)**

6 B. means dependent on said parameter for selecting the power level at which said  
7 modem either transmits, or receives, data or both.

1 161. A discrete multitone modem including a transmitter for communicating to a remote  
2 receiver at one of a plurality of power levels associated with particular communication  
3 conditions on a digital subscriber line and adapted to receive a power select signal indicat-  
4 ing a power level to be used for subsequent transmissions.

1 162. A discrete multitone modem according to claim 160 which includes means for  
2 communicating to another modem with which it communicates a power select signal indi-  
3 cating a power level to be used for subsequent transmissions.

1 163 A discrete multitone modem according to claim 160 which includes means for receiv-  
2 ing from another modem with which it communicates a power select signal indicating a  
3 power level to be used for subsequent transmissions.

1 164 A discrete multitone modem according to claim 160 in which said power select sig-  
2 nal identifies a specific power level at which said other modem is to receive data from it.

1 165. A discrete multitone modem according to claim 162 in which said power select sig-  
2 nal identifies a specific power level at which said other modem is to transmit data to it.

1 166. A discrete multitone modem according to either of claims 164 or 165 in which said  
2 discrete power level comprises one of several predefined power levels for communication  
3 between said modems.

1 167. A discrete multitone modem according to claim 162 in which the means for com-  
2 municating said power select signal includes means for transmitting said signal over at  
3 least one subchannel intermediate an upstream and a downstream set of data subchannels  
4 over which said modem communicates.

1 168. A discrete multitone modem according to claim 167 which the means for communi-  
2 cating said power select signal includes means for transmitting said signal over one or  
3 more data subchannels over which said modem communicates.

1 169. A discrete multitone modem according to claim 160 which includes a plurality of  
2 parameter sets stored in said modem and defining communications under a plurality of  
3 different communication conditions on said line.

1 170. A discrete multitone modem according to claim 169 in which said parameter sets  
2 include at least a primary set of parameters for controlling communications in the absence  
3 of a disturbance event, and a secondary set for controlling communications responsive to  
4 a disturbance event.

1 171. A discrete multitone modem according to claim 169 in which said monitoring means  
2 monitors the signal to noise ratio on one or more subchannels over which said modem  
3 communicates and selects a parameter set based on said ratio for controlling subsequent  
4 communications.

1 172. A discrete multitone modem according to claim 169 in which said parameter sets  
2 include a set of parameters defining the power level at which said modem transmits to  
3 other modems.

1 173. A discrete multitone modem according to 169 in which said parameter sets include a  
2 set of parameters defining the power level at which said modem receives communications  
3 from other modems.

1 174. A discrete multitone modem according to claim 173 in which said modem includes  
2 means for transmitting to another modem with which it is in communication a signal indi-  
3 cating a parameter set to be used in subsequent communications between said modems.

1 175. A discrete multitone modem according to claim 172 in which said modem includes  
2 means for receiving from another modem with which it is in communication a signal indi-  
3 cating a parameter set to be used in subsequent communications between said modems.

1 176. A discrete multitone modem according to claim 160 in which said modem commu-  
2 nicates to another modem a desired power level by itself changing the power level at  
3 which it communicates with said other modem.

-58-

1 177. A discrete multitone modem including a transmitter for communicating to a remote  
2 receiver at one of a plurality of power levels associated with particular communication  
3 conditions on a digital subscriber line and storing a plurality of sets of channel control pa-  
4 rameters corresponding to said power levels, comprising

5 A. means responsive to a disturbance event to select a power level at which said  
6 transmitter transmits to said receiver; and

7 B. means for communicating the selected power level to said receiver.

1 178. A discrete multitone modem including a transmitter for communicating to a remote  
2 receiver at one of a plurality of power levels associated with particular communication  
3 conditions on a digital subscriber line and storing a plurality of sets of channel control pa-  
4 rameters corresponding to said power levels and adapted to receive a power select signal  
5 indicating a power level to be used for subsequent transmissions.

1 179. A discrete multitone modem according to claim 177 in which the means for com-  
2 municating the change in power level transmits a power power select signal to the remote  
3 receiver indicative of the change in power level.

1 180. A discrete multitone modem according to claim 179 in which the transmitting means  
2 transmits a tone indicating the desired change in power level to the remote receiver.

1 181. A discrete multitone modem according to claim 179 in which the transmitting means  
2 transmits a plurality of tones indicating the desired change in power level to the remote  
3 receiver.

1 182. A discrete multitone modem according to claim 181 in which the plurality of tones  
2 designates a particular one of several power levels to which the remote receiver is to  
3 switch.

1 183. A discrete multitone modem according to claim 179 in which the means for com-  
2 municating the change in power level designates a particular one of several power levels  
3 to which the remote receiver is to switch.

**SUBSTITUTE SHEET (RULE 26)**

1 184. A discrete multitone modem according to claim 179 in which the means for com-  
2 municating the change in power level to the remote receiver includes means for transmit-  
3 ting a power power select signal over at least one subchannel intermediate an upstream  
4 and a downstream set of data subchannels over which said modem communicates.

1 185. A discrete multitone modem according to claim 177 in which the means for com-  
2 municating the change in power level to the remote receiver comprises

3 (1) means associated with the transmitter for effectuating the change in power  
4 level at said transmitter;

5 (2) means in the remote receiver responsive to the change in power level at the  
6 transmitter for changing the power level of its reception in accordance therewith.

1 186. A discrete multitone modem according to claim 177 in which the means for com-  
2 municating the change in power level to the remote receiver transmits to the remote re-  
3 ceiver a frame count at which the remote receiver is to effectuate the change in power  
4 level.

1 187. A discrete multitone modem according to claim 178 in which the means for receiv-  
2 ing the power select signal includes a frame count at which said modem is to effectuate  
3 the change in power level.

1 188. A discrete multitone modem according to claim 177 including a receiver responsive  
2 to communication of a power level change from a remote transmitter to thereby:

3 (1) measure at least one parameter indicative of communication conditions on  
4 said line responsive to said power level change, and

5 (2) select new channel control parameters from a plurality of sets of prestored  
6 channel control parameters based on said measurement.

1 189. A discrete multitone modem according to claim 188 which said at least one parame-  
2 ter comprises a signal to noise ratio of communications over said line.

-60-

1 190. A discrete multitone modem according to claim 188 which said at least one parame-  
2 ter comprises a characteristic of a monitor tone transmitted over said line.

1 191. A discrete multitone modem according to claim 188 which said characteristic com-  
2 prises at least the amplitude of said tone.

1 192. A discrete multitone modem according to claim 188 which said characteristic com-  
2 prises at least the phase of said tone.

1 193. A discrete multitone modem according to claim 188 which said characteristic com-  
2 prises at least the frequency of said tone.

1 194. A discrete multitone modem according to claim 189 in which said tone is transmit-  
2 ted over over at least one subchannel intermediate an upstream and a downstream set of  
3 data subchannels over which said modem communicates.

1 195. A discrete multitone modem according to claim 189 in which said signal to noise  
2 ratio is based on measurements of reference frames transmitted over said line.

1 196. A discrete multitone modem according to claim 26 in which said signal to noise ra-  
2 tio is based on measurements of data transmitted over said line.

1 197. A discrete multitone modem according to claim 177 in which the means responsive  
2 to a disturbance event comprises means for measuring at least one characteristic of said  
3 line indicative of communications on said line and for selecting a power level responsive  
4 to said measurement.

1 198. A discrete multitone modem according to claim 197 in which said characteristic  
2 comprises CRC errors and in which said measuring means signals a change in power level  
3 when said CRC errors exceed a defined threshold on a selected plurality of successive  
4 measurements thereof.

1 199. A discrete multitone modem according to claim 197 in which said characteristic  
2 comprises forward error correction coefficients and in which said measuring means signals  
3 a change in power level when the number of errors exceeds a defined threshold.

**SUBSTITUTE SHEET (RULE 26)**



1 200. A discrete multitone modem according to claim 199 in which said measuring means  
2 signals a change in power level when the number of uncorrected errors exceeds a defined  
3 threshold.

1 201. A discrete multitone modem according to claim 199 in which the means for com-  
2 municating the change in power level designates a single alternative power level to  
3 which the remote receiver is to switch.

1 202. A discrete multitone modem according to claim 177 which includes means in said  
2 modem for at least one parameter indicative of communication

1 203. A method of transmitting data over a wire line through upstream and downstream  
2 channels, respectively, from first and second pluralities of discrete-frequency subchannels,  
3 comprising the steps of:

4 A. storing at least first and second parameter sets defining data communications  
5 over said channels under at least two different communication conditions;

6 B. selecting a parameter set for use in communications in accordance with the  
7 prevailing communication condition.

1 204. The method of claim 203 in which said selecting step includes the step of monitoring  
2 communications on said line and transmitting and selecting said parameter set in accor-  
3 dance with said monitoring.

1 205. The method of claim 204 in which said monitoring step includes the step of measur-  
2 ing at least one communication indicium on said at least one subchannel.

1 206. The method of claim 205 in which said at least one indicium is selected from the  
2 group comprising signal to noise ratios, error rates, and the amplitude and frequency of  
3 tones.

1 207. The method of claims 203 or 206 which includes the step of transmitting over said  
2 line a signal that identifies the parameter set to be selected.

1 208. The method of claims 203 or 206 which includes the step of receiving over said line  
2 a signal that identifies the parameter set to be selected.

1 209. The method of claim 207 in which said signal is transmitted on a subchannel inter-  
2 mediate said upstream and downstream channels.

1 210. The method of claim 208 in which said signal is received on a subchannel interme-  
2 diate said upstream and downstream channels.

1 211. The method of claims 203, 206 or 207 in which said first parameter set defines  
2 communications over said line in the absence of a disturbance event and said second pa-  
3 rameter set defines communications over said line in the presence of a disturbance event.

1 212. The method of claims 203 or 211 in which said parameter sets include at least one  
2 parameter set from the group comprising subchannel bit allocations subchannel gains.

1 213. The method of claims 203 or 211 in which said parameter sets include at least one  
2 parameter set from the group comprising subchannel frequency domain coefficients, time  
3 domain coefficients, and echo cancellation coefficients.

1 214. The method of claims 212 or 213 in which said parameter sets include a first section  
2 for use in transmitting data over said line and a second portion for receiving data over said  
3 line.

1 215. A method of transmitting data over a wire line through upstream and downstream  
2 channels, respectively, from first and second pluralities of discrete-frequency subchannels,  
3 comprising the steps of:

4 A. signaling over said line to a remote receiver the intention to transmit data over  
5 said line at a selected one of a plurality of predefined power levels;

6 B. transmitting data over said line at said selected power level

1 216. The method of claims 214 or 219 which includes the step of monitoring communi-  
2 cations conditions on said line and selecting said power level in accordance therewith.

1 217. The method of claims 215 or 219 in which the step of selecting said power level in-  
2 cludes the step of selecting a first power level in response to detecting the absence of a  
3 disturbance event and selecting a second power level in response to detecting the pres-  
4 ence of a disturbance event.

1 218. The method of claim 217 in which said second power level is selected from a group  
2 of at least two power levels.

1 219. A method of transmitting data over a wire line through upstream and downstream  
2 channels, respectively, from first and second pluralities of discrete-frequency subchannels,  
3 comprising the steps of:

4 A. signaling to a remote receiver at one of a plurality of power levels;

5 B. receiving a signal from a receiver that determines said power levels.

1 220. The method of claim 219 in which said power levels are selected from a plurality of  
2 predetermined power levels having corresponding pre-stored parameter sets.

1 221. The method of claim 219 in which said power levels are received via said signal  
2 from said remote receiver.

1 222. The method of claim 219 in which said signal includes at least one signal selected  
2 from the group comprising a message, a tone, a collection of tones, or a flag.

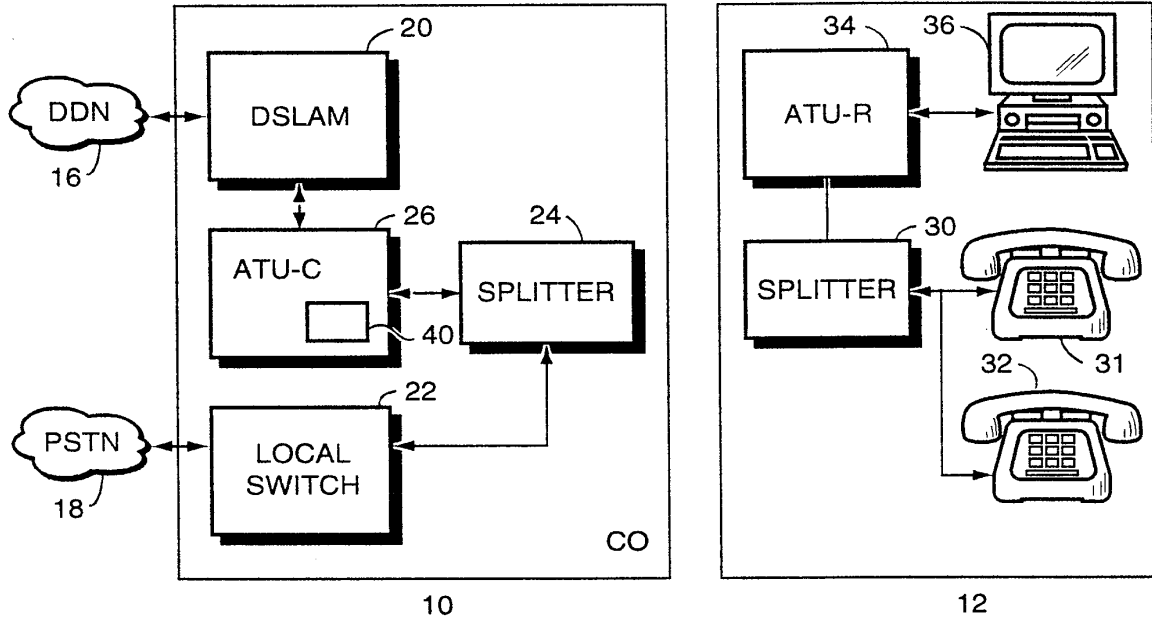

**FIG. 1 (PRIOR ART)**

	50	52	54
	SC	B	G
		:	:
42a	9	6	8
	10	6	8
	11	5	9
	12	6	8
		:	:
		:	:
42b	40	6	25
	41	6	26
	42	5	27
	43	4	28

42

**FIG. 2 (PRIOR ART)**

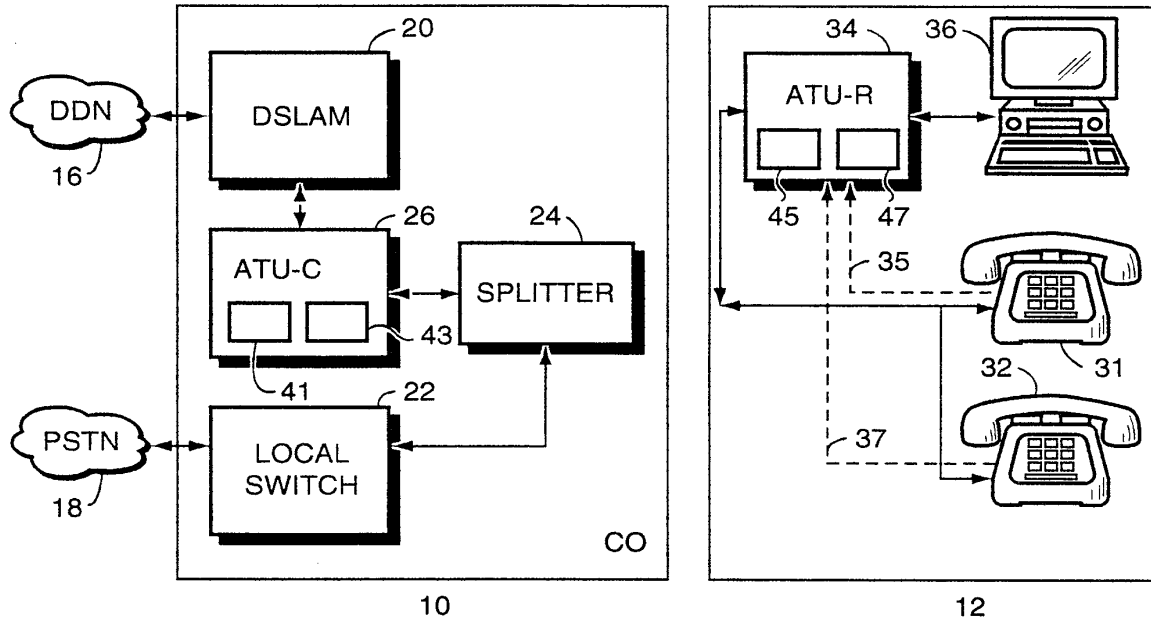

FIG. 3

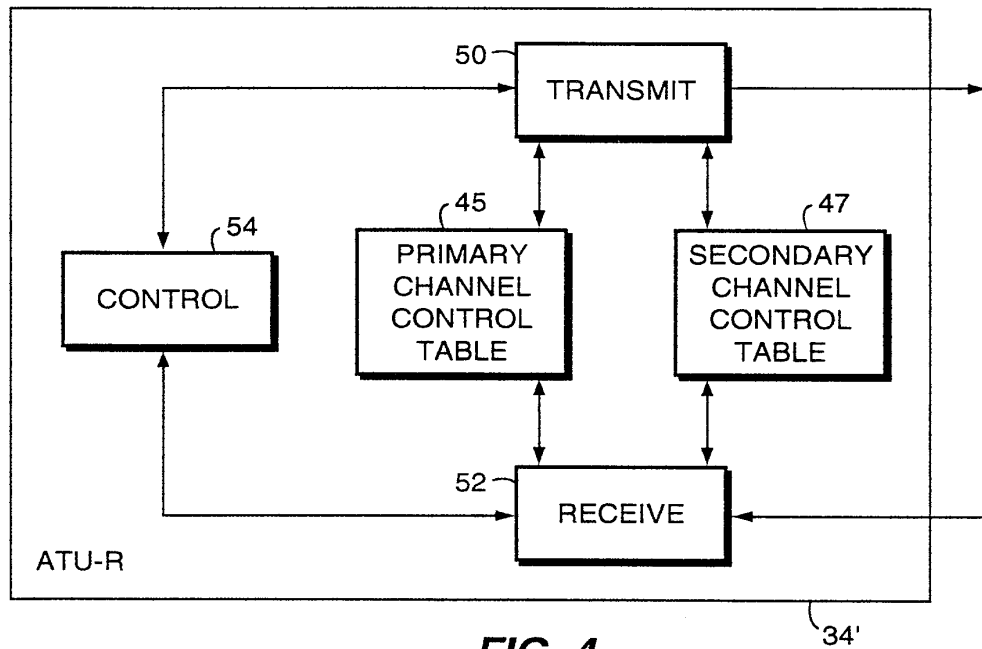

FIG. 4

3/6

	45c	45d	45e	45f	45g	45h
	SC	B	G	FDQ	TDQ	EC
45a	9	8	0			
	10	8	0			
	11	7	1			
	12	8	0			
45b	40	7	1	a	c	e
	41	7	1	a	c	e
	42	7	1	a	c	e
	43	6	1.3	b	d	f
	:	:	:	:	:	:

**FIG. 5A**

	47a						47b					47c				
	47f	47g	47h	47i	47j		B	G	FDQ	TDQ	EC	B	G	FDQ	TDQ	EC
	SC	B	G	FDQ	TDQ	EC										
47d	9	7	1				8	-8				8	-8			
	10	6	1.3				8	-8				8	-8			
	11	7	1				7	-8				7	-8			
	12	7	1				8	-8				8	-8			
47e	40	7	1	g	i	k	7	1	m	p	s	6	1.3	u	x	t
	41	7	1	g	j	k	6	1.3	n	q	t	4	1.6	v	y	1
	42	7	1	h	i	k	5	1.5	o	r	u	5	1.5	w	z	r
	43	6	1.3	g	i	l	6	1	n	q	t	6	1.3	v	x	t
	:	:	:	:	:		:	:	:	:		:	:	:	:	:

47

**FIG. 5B**

SUBSTITUTE SHEET (RULE 26)

4/6

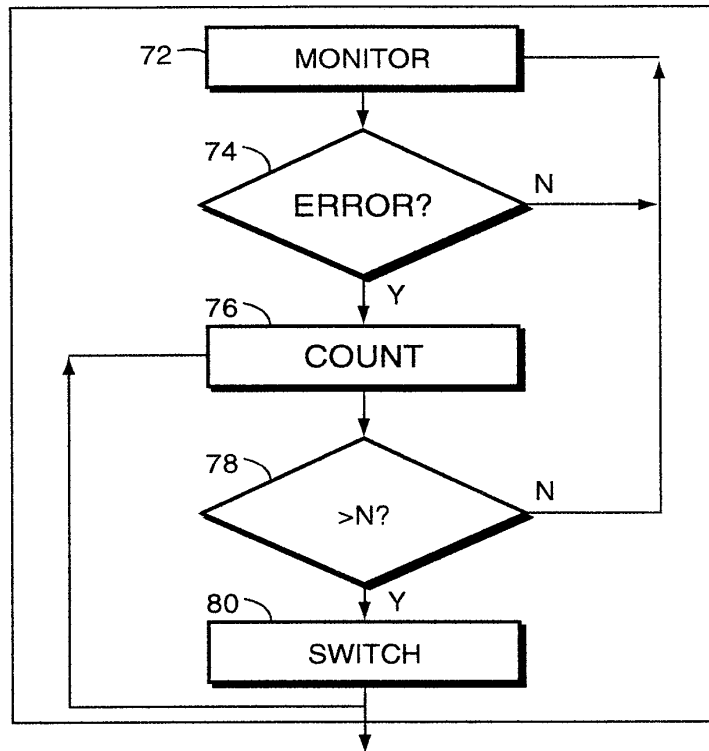

FIG. 6

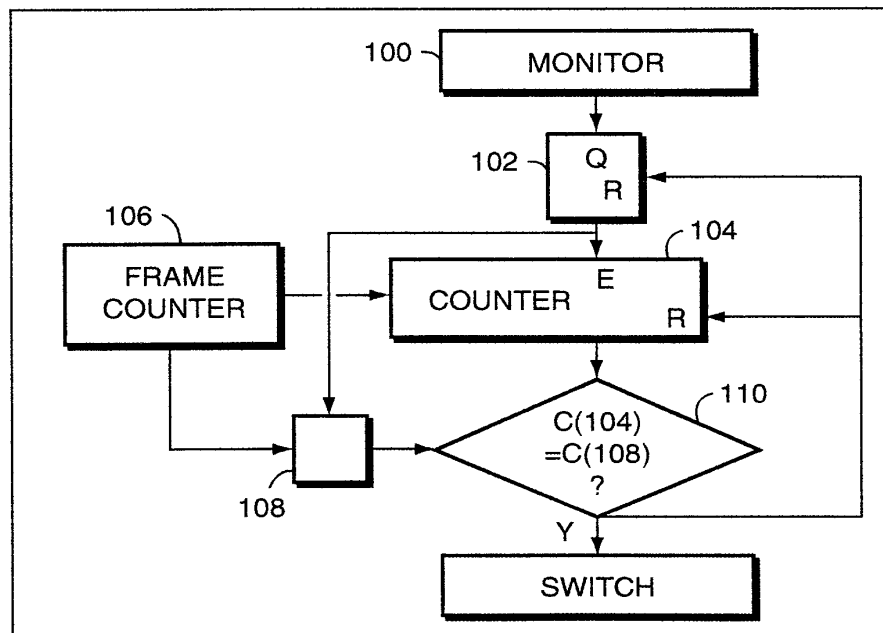

FIG. 7

SUBSTITUTE SHEET (RULE 26)

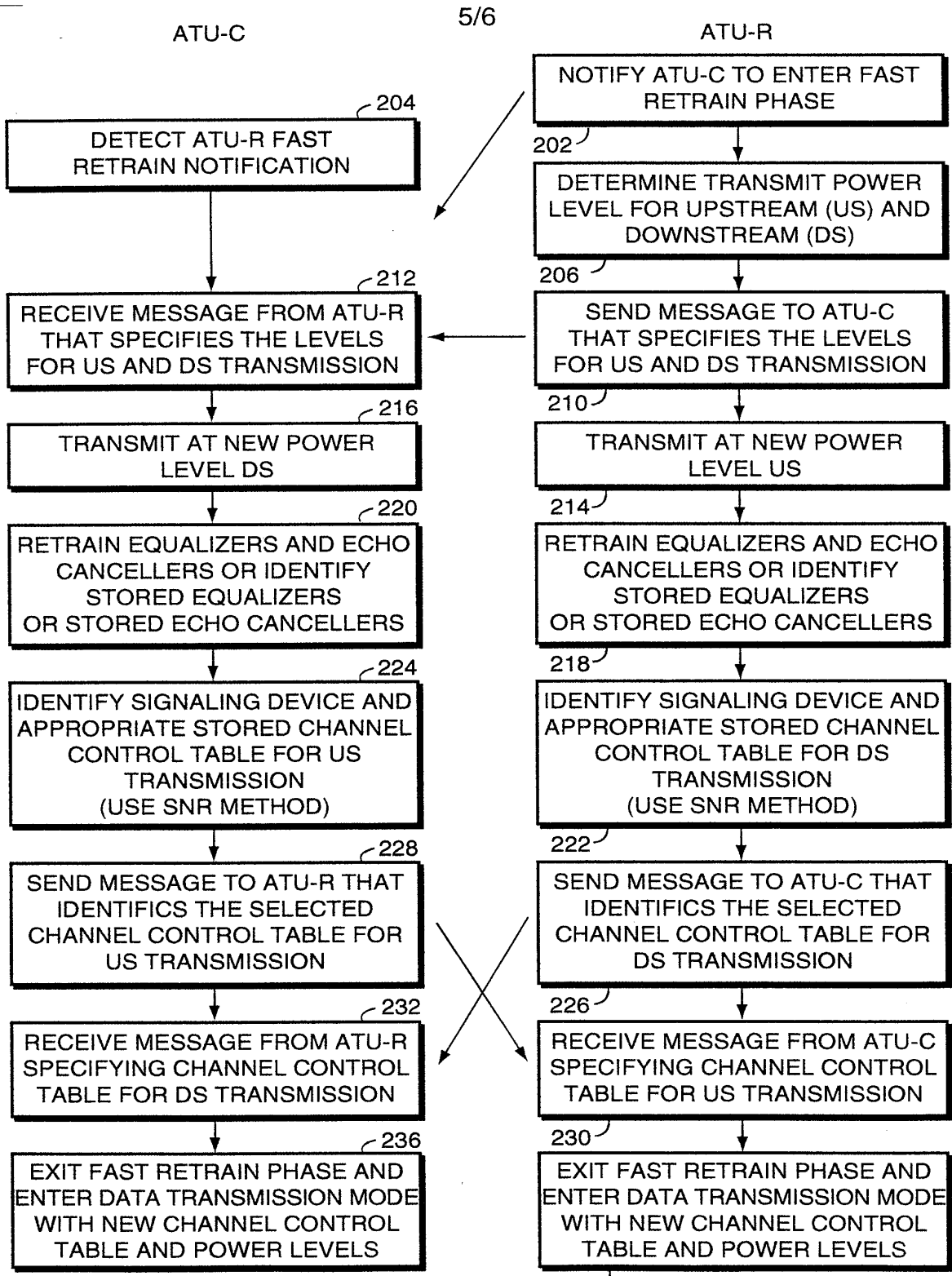

FIG. 8

SUBSTITUTE SHEET (RULE 26)



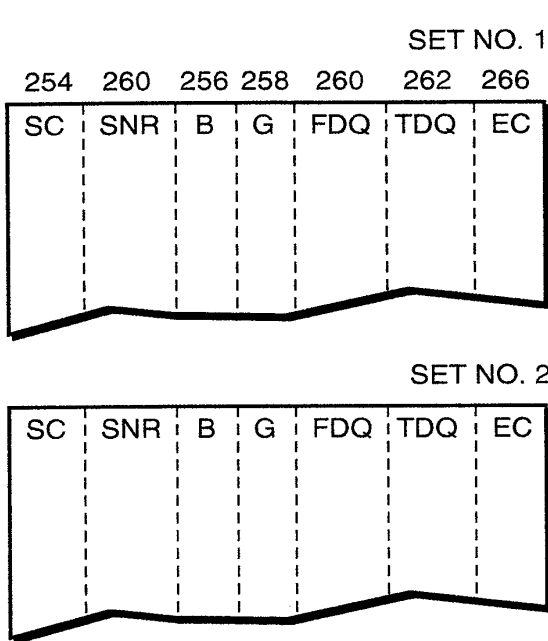

FIG. 9A

49e)	49a)	49b)	49c)	49d)	49f)	
SC	B1	B2	B3	B4	B5	B'
9	8	7	7	6	5	5
10	8	6	6	4	4	4
11	7	7	6	5	5	5
12	8	7	6	5	5	5
40	7	7	6	6	5	5
41	7	7	6	5	5	5
42	7	7	6	5	5	5
43	6	7	6	5	5	5
:	:	:	:	:	:	:

FIG. 5C

270      272      274      276  
 {SET No., SNR1, SNR2, SNR3, ...}

FIG. 9B

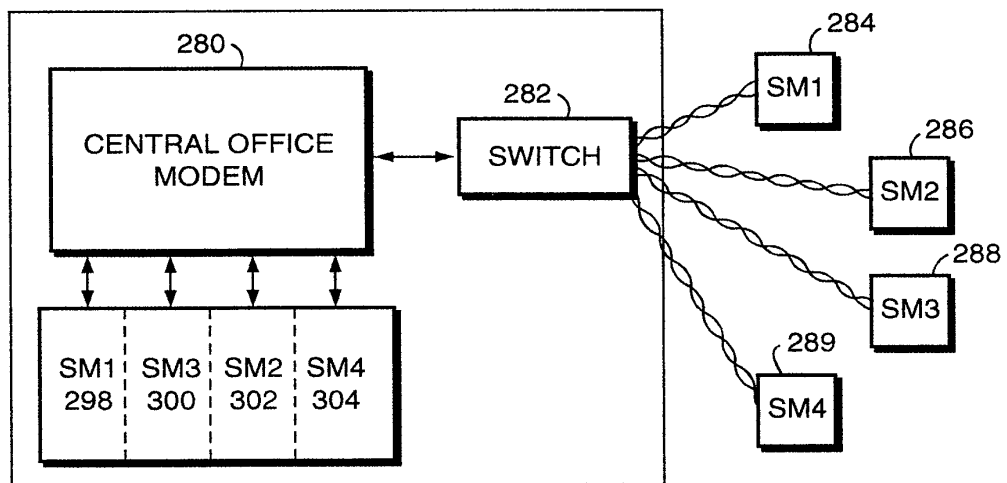

FIG. 10

SUBSTITUTE SHEET (RULE 26)



INTERNATIONAL APPLICATION PUBLISHED UNDER THE PATENT COOPERATION TREATY (PCT)

<p>(51) International Patent Classification <sup>6</sup> : <b>H04L 12/00</b></p>	<p><b>A2</b></p>	<p>(11) International Publication Number: <b>WO 99/26375</b> (43) International Publication Date: 27 May 1999 (27.05.99)</p>
<p>(21) International Application Number: PCT/US98/23336 (22) International Filing Date: 2 November 1998 (02.11.98) (30) Priority Data: 60/066,021 14 November 1997 (14.11.97) US (71) Applicant (for all designated States except US): TEKTRONIX, INC. [US/US]; 14150 S.W. Karl Braun Drive, Mail Stop 50-LAW, P.O. Box 500, Beaverton, OR 97077 (US). (72) Inventor; and (75) Inventor/Applicant (for US only): HAKANSON, Eric, W. [US/US]; 12190 N.W. Welsh Drive, Portland, OR 97229 (US). (74) Agent: BUCHER, William, K.; Tektronix, Inc., Mail Stop 50-LAW, P.O. Box 500, Beaverton, OR 97077 (US).</p>		<p>(81) Designated States: CA, CN, KR, US, European patent (AT, BE, CH, CY, DE, DK, ES, FI, FR, GB, GR, IE, IT, LU, MC, NL, PT, SE).  Published <i>Without international search report and to be republished upon receipt of that report.</i></p>

(54) Title: METHOD OF OPERATING A DIGITAL DATA DISTRIBUTION NETWORK

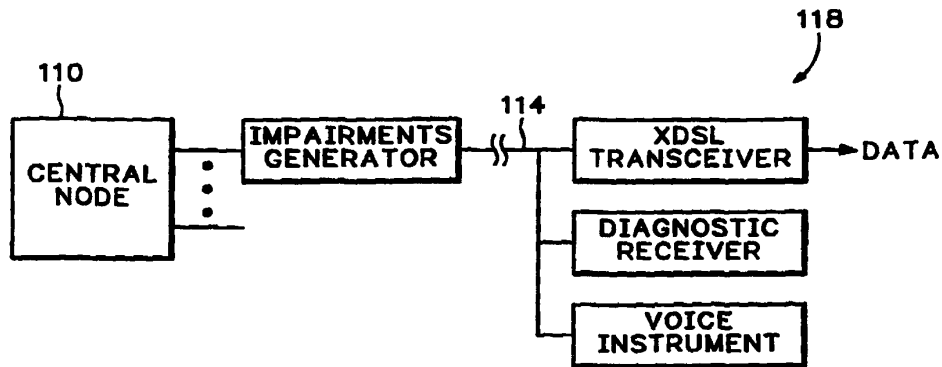

(57) Abstract

Digital data in error protected packets is used to modulate a carrier and the modulated carrier is impressed on a digital data distribution network for transmission to a receiver over a transmission path. In order to monitor operation of the data distribution network, the transmission path is impaired to a selected extent upstream of a transmission path segment that is to be tested and an error protected data packet is transmitted over the transmission path to the receiver. A determination is made at the receiver whether the received data packet is error free, and, if not, a message is transmitted from the receiver to the transmitter.

**FOR THE PURPOSES OF INFORMATION ONLY**

Codes used to identify States party to the PCT on the front pages of pamphlets publishing international applications under the PCT.

AL	Albania	ES	Spain	LS	Lesotho	SI	Slovenia
AM	Armenia	FI	Finland	LT	Lithuania	SK	Slovakia
AT	Austria	FR	France	LU	Luxembourg	SN	Senegal
AU	Australia	GA	Gabon	LV	Latvia	SZ	Swaziland
AZ	Azerbaijan	GB	United Kingdom	MC	Monaco	TD	Chad
BA	Bosnia and Herzegovina	GE	Georgia	MD	Republic of Moldova	TG	Togo
BB	Barbados	GH	Ghana	MG	Madagascar	TJ	Tajikistan
BE	Belgium	GN	Guinea	MK	The former Yugoslav Republic of Macedonia	TM	Turkmenistan
BF	Burkina Faso	GR	Greece	ML	Mali	TR	Turkey
BG	Bulgaria	HU	Hungary	MN	Mongolia	TT	Trinidad and Tobago
BJ	Benin	IE	Ireland	MR	Mauritania	UA	Ukraine
BR	Brazil	IL	Israel	MW	Malawi	UG	Uganda
BY	Belarus	IS	Iceland	MX	Mexico	US	United States of America
CA	Canada	IT	Italy	NE	Niger	UZ	Uzbekistan
CF	Central African Republic	JP	Japan	NL	Netherlands	VN	Viet Nam
CG	Congo	KE	Kenya	NO	Norway	YU	Yugoslavia
CH	Switzerland	KG	Kyrgyzstan	NZ	New Zealand	ZW	Zimbabwe
CI	Côte d'Ivoire	KP	Democratic People's Republic of Korea	PL	Poland		
CM	Cameroon	KR	Republic of Korea	PT	Portugal		
CN	China	KZ	Kazakstan	RO	Romania		
CU	Cuba	LC	Saint Lucia	RU	Russian Federation		
CZ	Czech Republic	LI	Licchtenstein	SD	Sudan		
DE	Germany	LK	Sri Lanka	SE	Sweden		
DK	Denmark	LR	Liberia	SG	Singapore		
EE	Estonia						

## METHOD OF OPERATING A DIGITAL DATA DISTRIBUTION NETWORK

Background of the Invention

This invention relates to method of operating a digital  
5 data distribution network.

In a conventional cable television system, a video  
information signal in analog form, such as the NTSC composite  
video signal, is employed to modulate the RF carrier of an  
assigned RF transmission frequency channel at the system  
10 headend and the RF signal is distributed over a cable network  
to multiple subscriber nodes. At a subscriber node there may  
be a cable-ready television receiver including a tuner which  
can select the frequency channel and a detector which  
recovers the video information signal from the selected  
15 channel and employs it to control operation of the television  
display.

A data distribution system in which the information  
signal is transmitted in digital form has well known  
advantages over a system in which the information signal is  
20 transmitted in analog form. Accordingly, it has been  
proposed by the United States Federal Communications  
Commission (FCC) that terrestrial transmission systems under  
the jurisdiction of the FCC should phase out use of the NTSC  
composite video signal by 2007 and should instead use digital  
25 video information signals to modulate RF carriers. The  
digital video information signal provided by a video signal  
source will then be composed of a succession of bits  
segregated into digital data packets. The data packets  
modulate an RF carrier which is broadcast from the  
30 transmitter. Each period of the RF carrier conveys several  
bits of the digital information signal in one symbol. For  
example, in the 64QAM modulation scheme, each symbol conveys  
six bits of the digital information signal. The television  
receiver selects the frequency channel, detects an analog  
35 information signal, converts the detected information signal  
to digital form and recovers the digital data packets. The

digital information signal is then used to control operation of the television display.

The change in standards from analog to digital for terrestrial television transmission effectively dictates that cable television systems will also have to provide digital video signals in order for the video signals to be compatible with digital television receivers.

Referring to FIG. 1, a digital cable television system includes a digital processing interface 8 which receives a digital video information signal, such as the MPEG transport stream, and generates an error protected digital signal composed of a succession of error protected digital signal packets. The error protected digital signal is applied to a modulator 10 which employs it to modulate an RF carrier which is typically in the frequency range 50-550 MHz, although it may be higher or lower. The digitally modulated RF carrier is supplied to a transmitter 14 which impresses the signal on a propagation medium 16. In the case of a cable television system, the propagation medium is a network of coaxial cables configured as a trunk extending from the transmitter 14 and having numerous branches connected to the trunk by directional couplers 18, sub-branches connected to the branches by directional couplers, and so on, and connected at the subscriber nodes to digital television receivers 20.

Each receiver 20 has a front end 22 including a tuner (not shown) which converts the RF signal to intermediate frequency and an analog-to-digital converter (ADC) 26 which digitizes the IF signal and provides a digital output signal to a demodulator 30. The demodulator 30 removes the IF component and provides a digital output signal, which, ideally, should match the error protected digital signal provided to the modulator 10. The receiver front end 22 also includes a digital processing circuit 32 which carries out the inverse of the error protection algorithm employed at the headend and ideally provides at its output a digital video information signal which matches the signal supplied to the digital processing interface 8. The digital video

information signal from the digital processing circuit 32 is supplied through a decoder (not shown) which the MPEG transport stream and supplies an analog video signal to display circuitry 34 to control operation of the television display.

Error protection is employed in the digital cable television system to allow correction of bit errors, i.e. incorrect values of digital 1 or digital 0, in the output signal of the demodulator 30 caused by impairments in the transmission path from the input of the modulator 10 to the output of the demodulator 30.

Provided that the bit error rate is below a critical value, known as the critical bit error rate and generally considered to be about  $10^{-4}$  for a digital television signal, digital error correction techniques can correct the errors and provide a signal having a bit error rate that may be less than  $10^{-11}$ , which is sometimes referred to as quasi-error free. The maximum bit error rate that can be tolerated is considered to be about  $10^{-3}$  before error correction.

Some video signals in a cable system are transmitted in encrypted form in order to restrict their use to subscribers who have paid an additional fee, either on a periodic basis for premium channels or on a pay-per-view basis for particular programs. In this case, the digital processing interface 8 not only applies a digital error protection algorithm but also encrypts the digital video information signal, so that the digital data packets provided to the modulator 10 are error protected and encrypted. In order to decrypt the digital data packets and regenerate the analog video signal, the subscriber is provided with a set top terminal 40 which is connected between the cable system connection and the display circuitry 34, by-passing the front end 22. The set top terminal includes a tuner (not shown) an ADC 42, a demodulator 44 and a digital processing circuit 46, performing the same general functions as the front end 22, but the digital processing circuit 46 performs not only error correction to recreate the digital signal applied to the

modulator 10 but also decryption in order to extract the digital video information signal supplied to the digital processing interface 8. It is expected that much of the programming distributed by digital transmission cable systems will be transmitted in encrypted form, so that a subscriber will need a set top terminal, or equivalent functionality built into the television receiver, in order to display a variety of programming.

The economic value of a cable television distribution system resides in its ability to distribute video payload, i.e. the program material that subscribers wish to view, to a large number of subscribers without excessive degradation. The system operator derives revenue based on the system's ability to distribute the video payload. Accordingly, it is important that the system operator be warned of impairments in the distribution system, so that these impairments can be corrected before they adversely affect the ability of the system to distribute video payload and hence the revenue derived by the system operator. The operator must therefore be able to measure impairments in transmission quality so that appropriate repairs can be made. Typical impairments that should be detected and repaired are reductions in signal-to-noise ratio (SNR), e.g. due to noise being coupled into the transmission channel, reductions in frequency response, reductions in phase response, phase noise, jitter, addition of interfering signals and addition of multipath signals.

Hitherto, it has been suggested that the bit error rate of an RF digital transmission system may be a satisfactory measure of transmission channel quality, but this measure is subject to disadvantage because an RF data distribution system in which the information signal is digital is subject to the "cliff effect," in that the curve that relates bit error rate to the quality of the transmission channel, expressed as signal-to-noise ratio, has a very steep drop off. Thus, referring to FIG. 2, a change of less than 1.5 dB in signal-to-noise ratio can cause the bit error rate to

change from less than  $10^{-4}$  to more than  $10^{-3}$ . The curves shown in FIG. 2 assume that the only impairment is noise when in fact there will always be other impairments, which can make the drop off even steeper. Accordingly, the system operator is not alerted to impairment of the transmission quality of the channel either by BER measurements or by a relatively small increase in subscriber complaints. On the contrary, the operator may not learn of an impairment until the system fails. This makes it difficult to monitor the noise margin in the system, to track degradations and fix degradations before a system failure.

In a report issued by the European Telecommunications Standards Institute (ETR 290: May 1997), it is suggested that the estimated noise margin is a better indicator of transmission channel quality than bit error rate. The estimated noise margin is based on the probability of mathematically added noise causing a bit error and is approximately the difference between the current estimated signal-to-noise ratio and the estimated signal-to-noise ratio at which the bit error rate exceeds the critical bit error rate. Use of the estimated noise margin to identify impairments is subject to disadvantage because it is computationally expensive and is not applicable to impairments other than noise. Further, its reliability is limited because there is an unknown set of errors associated with calculating the estimated noise margin. Since the estimated noise margin is not the same as the actual noise margin, there is a possibility that the current signal-to-noise ratio is substantially less than the estimated signal-to-noise ratio, and consequently the actual noise margin may be substantially less than the estimated noise margin. It would therefore be desirable to determine the actual noise margin of the transmission channel.

#### 35 Summary of the Invention

In accordance with a first aspect of the invention there is provided a method of operating a digital data distribution



network having a transmitter and a receiver, wherein digital data is transmitted in error protected packets from the transmitter to the receiver over a transmission path by employing the digital data to modulate at least one carrier and impressing the modulated carrier on the network, said method comprising (a) generating an error protected data packet for transmission over the transmission path, (b) impairing the transmission path to a selected extent upstream of a transmission path segment that is to be tested, (c) transmitting the data packet over the transmission path, (d) receiving the data packet at the receiver, and (e) determining whether the received data packet is error free.

In accordance with a second aspect of the invention there is provided a method of operating a digital data distribution network having a transmitter and a receiver, wherein digital data is transmitted in error protected packets from the transmitter to the receiver over a transmission path by employing the digital data to modulate at least one carrier and impressing the modulated carrier on the network, said method comprising (a) generating an error protected data packet for transmission over the transmission path, (b) transmitting the data packet over the transmission path as an analog signal, (c) receiving the analog signal at the receiver, (d) recording the analog signal received at the receiver, and (e) transmitting the record of the analog signal to a remote location for analysis.

In accordance with a third aspect of the invention there is provided a method of operating a digital data distribution network having a transmitter and a receiver, wherein digital data is transmitted in error protected packets from the transmitter to the receiver over a transmission path by employing the digital data to modulate at least one carrier and impressing the modulated carrier on the network, said method comprising generating an error protected data packet for transmission over the transmission path, impairing the transmission path to a selected extent upstream of a transmission path segment that is to be tested, transmitting

the data packet over the transmission path, receiving the data packet at the receiver, and counting bit errors in the received data packet.

In accordance with a fourth aspect of the invention  
5 there is provided a method of operating a digital data distribution network having a transmitter and a receiver, wherein digital data is transmitted in error protected packets from the transmitter to the receiver over a transmission path by employing the digital data to modulate a  
10 carrier and impressing the modulated carrier on the network, said method comprising (a) generating an error protected data packet for transmission over the transmission path, (b) impairing the transmission path to a selected extent upstream of a transmission path segment that is to be tested, (c)  
15 transmitting the data packet over the transmission path as an analog signal, and (d) receiving the analog signal at the receiver.

#### Brief Description of the Drawings

20 For a better understanding of the invention, and to show how the same may be carried into effect, reference will now be made, by way of example, to the accompanying drawings, in which

FIG. 1 is a partial schematic block diagram of a  
25 proposed form of cable television system,

FIG. 2 is a graph illustrating bit error rate as a function of signal-to-noise ratio in a digital data communication system.

FIG. 3 is a partial schematic block diagram of the  
30 headend and receiver in a cable television system embodying the present invention,

FIG. 4 is a map of part of a cable television system,  
and

FIG. 5 is a partial schematic block diagram of a digital  
35 subscriber line system.

Detailed Description

A first application of the invention will be described with reference to a digital cable television system.

The cable TV system shown in FIGS. 3 and 4 is used to  
5 distribute digital video information signals from a headend 48 to subscriber nodes 50. Referring to FIG. 3, the headend 48 includes a digital processing interface 8, a modulator 10 and a transmitter 14 similar to the corresponding elements shown in FIG. 1. The digital processing interface receives  
10 the MPEG 2 transport stream and performs various operations, including energy dispersal, error protection, interleaving and base band shaping in order to generate inphase and quadrature signals which are applied to the modulator 10. All the functions of the digital processing interface, and  
15 possibly also the functions of the modulator, may be performed in a single integrated circuit. In addition, the headend 48 includes an impairments generator 60. The impairments generator 60 may be located between the transmitter 14 and the cable network 16, as shown in FIG. 3,  
20 or it may be incorporated in the digital processing interface 8 or the modulator 10. The effect of the impairments generator 60 is to degrade to a selectively controllable extent the quality of the transmission path between the digital processing interface 8 and the subscriber nodes 50.  
25 The impairments generator may function by adding noise to the transmission channel or degrading the frequency response or phase response of the transmission channel. Further, the impairments generator may introduce "spurs" (spurious modulation products) and phase noise or jitter. The manner  
30 in which the impairments can be applied to the transmission channel is well known to those skilled in the art. Considering, for example, the signal-to-noise ratio, the quality of the channel may be degraded at the headend using an impairments generator that couples noise into the  
35 transmission channel. The extent to which the signal-to-noise ratio is degraded depends on the amplitude of the noise.

As shown in FIG. 4, the cable network 16 includes a trunk extending from the headend 48. Branches and sub-branches are connected to the trunk by directional couplers 18. Each subscriber node 50 is at the end of a branch or sub-branch. The cable system operator maintains a map of the cable network, showing schematically the topology of the path to each subscriber node 50. At each active subscriber node 50, there is a diagnostic cable receiver 64 (FIG. 3) connected between the cable network and the display circuitry 34 of the subscriber's digital television receiver. The cable receiver 64 may be implemented as a set top terminal or it may be housed in the same cabinet as the digital television receiver. Each cable receiver has a unique ID and the cable system operator maintains a database relating cable receiver IDs with the subscriber nodes and billing addresses.

If the database also relates the cable receiver IDs with physical addresses, the system operator is able to determine not only the physical location of each cable receiver but also the topology of the path between the headend and each cable receiver.

Referring to FIG. 3, the cable receiver 64 includes a tuner (not shown) for converting the received signal to the intermediate frequency, an ADC 66, a demodulator 68, a digital processing circuit 70 and a decoder (not shown), similarly to the set top terminal 40 described with reference to FIG. 1. A controller 74 included in the cable receiver controls operation of the other components of the cable receiver 64.

The capabilities of the digital processing circuit 70 are expanded relative to those of the digital processing circuit 46. The digital processing circuit 70 has a video data output for supplying the MPEG transport stream to the decoder, which supplies an analog video signal to the display circuitry 34 of the digital television receiver. The digital processing circuit 70 includes an error bits counter which accumulates the number of error bits in the received signal. The error bits counter can be queried by the controller 74

and reset from time to time, so that the controller is able to calculate the bit error rate based on the error bit count and the time that has elapsed since the counter was reset. The controller 74 supplies a digital data word representing the calculated value of the bit error rate to a digital processing interface 76, which produces an error protected data packet.

The cable receiver 64 also includes a memory 80 which can be enabled to store the output signal of the ADC 66 during a selected interval. The stored digital signal is applied to the digital processing interface 76 to generate an error protected data packet. The error protected data packet produced by the digital processing circuit 76, either from the bit error rate word or from the signal provided by the memory 80, is supplied to a modulator 82. The modulator 82 uses the error protected data packet to modulate an RF carrier, typically at a frequency in the range 5-50 MHz, although it may be higher or lower. The modulated RF signal is applied to a transmitter 84 which impresses the signal on the cable network.

The headend 48 of the cable system also includes a receiver 90 for receiving the return messages provided by the transmitter 84 in each of the cable receivers 64. The receiver 90 includes a tuner (not shown), an ADC 92 which digitizes the return message signal, a demodulator 94 which removes the IF component and provides a digital output signal which, ideally, should match the error protected return message packet provided by the digital processing interface 76, a digital processing circuit 96 which carries out the inverse of the error protection algorithm employed in the digital processing interface 76 and ideally provides at its output a data signal which matches the input signal provided to the digital processing interface 76, and a report/display device 98. It will be understood that the headend includes a controller (not shown) for controlling operation of the various components thereof.

In a first mode of operation of the cable television system shown in FIG. 3, the system is used to measure the bit error rate of the transmission channel to each of the subscriber nodes. In this mode of operation, the headend controller issues a signal which is transmitted to the cable receivers, instructing the cable receivers to calculate bit error rate during a selected measurement interval, which may be defined by reference to start and stop flags included in the data stream or by reference to specific start and stop times supplied to the cable receivers by the headend.

During the measurement interval, the controller 74 calculates the bit error rate and provides an output word representative thereof. The calculated bit error rate is reported back to the headend with the cable receiver ID and a report or display is generated. The report/display device may accumulate information received from numerous cable receivers 64 and generate a report or display showing trends in bit error rate with time.

Alternatively, or in addition, the report/display device may generate a report or display showing bit error rate as a function of the locations of the cable receivers in the cable network, for example. The system operator is thereby able to determine, on a node-by-node basis, the bit error rates of the signal propagation paths between the transmitter 14 and the subscriber nodes. By comparing the bit error rates reported by different cable receivers, the cable system operator may be able to determine the location in the cable network of a particular impairment. For example, referring to FIG. 4, if the cable receivers at nodes 50C and 50D have poor transmission margin compared to the terminals at nodes 50A, 50B, 50E and 50F, indicated by high bit error rate, then it is likely that there is an impairment between the directional couplers  $18_2$  and  $18_{2,1}$ .

It will be appreciated that a test of this nature will generate a response message from each cable receiver, and accordingly it may be advantageous to instruct only selected

cable receivers to calculate the bit error rate and provide return messages.

As noted previously, the bit error rate of the propagation path may be of limited value for monitoring  
5 degradation of the transmission quality, and it may be better to measure noise margin.

In order to measure the noise margin, i.e. the difference between the current signal-to-noise ratio and the SNR at which the bit error rate exceeds the critical bit  
10 error rate, the headend controller instructs the cable receivers (or a selected group of cable receivers) to report when the bit error rate calculated by the controller 74 exceeds the critical bit error rate. The headend controller operates the impairments generator 60 to add a noise  
15 impairment to the signal emitted by the transmitter. The noise amplitude is progressively increased, for example in stair-step fashion. In each of the cable receivers addressed by the headend controller, the controller 74 provides an output indicating the bit error rate. When the bit error  
20 rate at a given cable receiver 64 without addition of the noise impairment is sufficiently low, and the bit error rate with addition of the noise impairment exceeds the critical bit error rate, the level of impairment introduced by the impairments generator is approximately equal to the noise  
25 margin for the transmission channel from the transmitter 14 to that cable receiver. (If the impairments generator were upstream of the transmitter, the level of impairment introduced by the impairments generator would be related to the noise margin for the segment of the transmission path  
30 between the impairments generator and the cable receiver.) The cable receiver reports that the critical bit error rate has been exceeded, and includes its ID in the report. The cable system operator is thereby able to determine the noise margin to critical bit error rate on a node-by-node basis by  
35 correlating the cable receiver IDs with the level of impairment at which each cable receiver provides a report. It is, of course, necessary to correlate the report that the

critical bit error rate has been exceeded with the noise level at which the report was generated. This may be accomplished by including framing bits in the signal transmitted by the head end in the event that the cable receiver reports immediately that the critical bit error rate has been exceeded. Alternatively, the headend controller may maintain a log recording level of impairment as a function of time and the report could include a time stamp indicating the time at which the critical bit error rate was exceeded.

10 It may be helpful in locating system impairments in the system shown in FIG. 3, to apply an impairment to the transmission channel and observe the effect of that impairment at multiple locations simultaneously.

If there is an impairment in the trunk of the cable network or in a major branch, it is likely that many cable receivers will respond to the stair-step type of impairment and the reverse transmission system would become jammed by the message storm. This can be avoided by testing all cable receivers at relatively short intervals, with a small level of impairment. Appropriate selection of the level of impairment should ensure that relatively few cable receivers will report a malfunction or failure condition. If this indeed occurs, the operator then has confidence that the transmission channel has a reasonable margin. If there is an unexpectedly large number of return messages, the headend controller may broadcast a message to all cable receivers instructing them not to send error information but to reset and measure again. The headend then repeats the test with a lower level of impairment in order to locate the regions of the network for which the noise margin is smallest. At longer intervals, e.g. daily or monthly, the operator tests all cable receivers with a stair-step sequence of impairments preceded by a message that the cable receivers should report the result of the test only when polled. The headend then polls the cable receivers and the cable receivers respond to the poll by reporting the actual transmission margin. The polling is best done during an idle period, so as not to



interfere with revenue generating transmissions. Since the transmission margin from the headend to each cable receiver can be inexpensively monitored, the problem of locating an impairment in the cable network is greatly simplified.

5           If multiple impairments exist, it can be difficult to locate the impairment responsible for a failure condition. For example, referring to FIG. 4, the reduction in transmission margin downstream of an impairment in cable segment 102 may be quite small and may be swamped by another  
10           impairment upstream in the system, e.g. in cable segment 104. Alternatively, two different impairments, e.g. in cable segments 102 and 106, may cause similar reductions in transmission margin, thus leading to the erroneous conclusion that there is a single impairment in a branch that is common  
15           to the nodes 50C and 50E, e.g. cable segment 104. If the impairments are of different types, e.g. noise and jitter, this problem can be solved by classifying the impairments.

          In order to classify impairments, it is necessary to observe the effect of the impairments on symbols, as opposed  
20           to the bits used to encode the symbols.

          Impairments can be classified by comparing the waveform of the signal received at the subscriber node with the waveform of the transmitted signal.

          This is accomplished by using the memory 80 to capture  
25           the digital output signal of the ADC 66 during a test interval and transmitting the captured waveform back to the headend. The digital processing circuit 96 provides an output signal that matches the captured portion of the output signal of the ADC 66 and can be compared with the output  
30           signal of the transmitter 14 during the corresponding time interval, so that the effect of the impairments on symbols can be determined.

          Alternatively, the captured sample of the waveform can be analyzed locally using a measurement instrument.

35           There are several ways in which impairments can be classified. One technique is to derive the error vector waveform and extract the spectrum of the error vector. The

presence of various impairments, such as noise, coherent distortions and spurious modulation products, can be deduced from the spectrum of the error vector. Amplitude and phase modulation impairments can be deduced from the Hilbert  
5 Transform of the error vector waveform.

The error vector waveform is derived by subtracting the signal received at the input of the cable receiver from the transmitted signal. Typically, the cable receiver will include an equalizer downstream of the ADC, often as part of  
10 the demodulator. If the equalizer is upstream of the point at which the received signal is read for storing in the memory 80, it affects the timing of the received signal and its effect must be removed in order for the received signal waveform to reflect the condition of the transmission path.  
15 This can be accomplished by using the equalizer coefficients to create a digital filter having a transfer function that is the inverse of the transfer function of the equalizer. The error vector waveform is then generated by subtracting the output waveform of the digital filter from the transmitted  
20 waveform.

Once the impairments have been classified, a particular existing system impairment is chosen for testing. The chosen impairment might be the impairment suspected of most likely causing a reduced transmission margin. The impairments  
25 generator then adds this impairment, at a sufficient level that the combined effect of the existing system impairment and the added impairment will be greater than the level previously detected for the existing impairment. Since the normal cable receiver is not calibrated for level, and there  
30 is a potential for destructive interference between the existing system impairment and the added impairment, the new aggregate level of impairment is best measured by repeating the recording and classification process and determining by how much the level of impairment has changed. If addition of  
35 this impairment causes a system failure report from the cable receiver at one subscriber node but not from the cable

receiver at another node, it can be inferred that the two nodes are affected by different impairments.

If multiple similar impairments exist simultaneously, the impairments cannot be separated by classification and the  
5 problem of locating the impairments is more complex.

However, if several of the diagnostic cable receivers are instructed to record the received waveform simultaneously, signal processing of the digitized waveforms can be used to extract the separate locations of the multiple similar  
10 impairments. The cable receivers can be made to measure simultaneously by means of two mechanisms. In accordance with the first mechanism, a protocol that instructs all cable receivers (possibly just all unused cable receivers or just selected cable receivers) to tune to a particular channel and  
15 stop recording when the end of a particular data packet is received can be broadcast to all (or some) cable receivers. This method can provide robust, but relatively coarse, timing. More precise time correlation can be achieved by inserting a time mark in the broadcast waveform, and suitable  
20 signal processing can then be used to align the received waveforms with the broadcast waveform. The time mark may be inserted by transmitting a message such that there will be a transition through a selected signal level, e.g. zero volts, at a selected time, typically late in a packet.

25 One way of extracting the separate locations of multiple impairments has two steps. First, the error vector waveform for each subscriber node is generated by subtracting the transmitted waveform from the waveform received at each node. Second, the cross-correlation function  $cev(X, Y)$  of the  
30 error vector waveforms for two subscriber nodes  $50X$  and  $50Y$  is derived. Error vectors that are common to the two nodes are revealed by the cross-correlation function. When computing the cross-correlation functions along the logical path of the network from an end point (such as a subscriber  
35 node) toward the transmitter, the location of the impairment can be determined when the value of the cross-correlation function becomes smaller. For example, referring again to

FIG. 4, and assuming that cev (E, F) indicates a common impairment and cev (A, F) indicates that the common impairment is missing, there must be an impairment between the logical locations of nodes 50A and 50E in the transmission path to node 50F. If cev (C, F) indicates a common impairment, the impairment must be between the nodes 50A and 50C. Since the only part of the network between nodes 50A and 50C that is in the transmission path to node 50F is the segment between the coupler 18<sub>1</sub> and the coupler 18<sub>2</sub>, the impairment must be located there.

As a second example, if cev (C, D) indicates a common impairment and cev (A, D) indicates that the common impairment is missing, there must be an impairment logically located between node 50A and the coupler 18<sub>2, 1</sub>. This implies that the impairment must be located between the directional coupler 18<sub>1</sub> and the coupler 18<sub>2, 1</sub>. If cev (D, E) indicates that the common impairment is missing, the impairment is not between directional coupler 18<sub>1</sub> and the directional coupler 18<sub>2</sub>, and so the impairment must be between the directional coupler 18<sub>2</sub> and the coupler 18<sub>2, 1</sub>.

It is necessary to carry out the tests using the impairments generator with minimal disturbance to the revenue generating communication traffic. This is accomplished by adding the impairments only to selected packets or segments of data having a relatively low value with respect to the revenue generating communication traffic.

Most digital video transmission systems utilize the MPEG transport stream. The MPEG transport stream is composed of several MPEG elementary streams which are multiplexed to produce the MPEG transport stream. Stuffing bits are inserted in order to create the constant bit rate MPEG transport stream. It is important that the impairment should degrade only the stuffing bits or other non-customer (i.e. non-payload) bits. Since the impairments are added in the analog domain (in the case of the impairments generator being downstream of the transmitter), the impairments are applied to the transmitted symbols, in which several bits are

encoded. Interleaving in constructing the transmitted data stream may result in a symbol containing bits derived from multiple elementary streams. Accordingly, it is necessary to detect when a symbol consists entirely of non-customer bits and degrade only those symbols. The cable receiver 64 can be instructed to pick out a degraded symbol by including a private data message in the MPEG transport stream. The message might, for example, instruct the cable receiver to pick out a numerically specified symbol after the next sync byte after the Program Clock Reference for a specified Program ID. It will be appreciated that the impairments could be added in the digital domain, e.g. in the digital processing interface 8. In this case, while the impairments are added in the digital domain, they are nevertheless a description of the desired analog waveform, so the impairments are of an analog nature.

An alternative is to include the impairment at a time when all of the payload bits are of relatively low perceived value. For example, the operator might include a special announcement simultaneously on all of the program streams contained in a single transmitted channel. The time of transmission of this announcement is chosen so that the balance between the loss of advertising revenue and the benefit of announcing the quality enhancement efforts is optimized. The announcement might indicate that the system operator is testing the network to ensure that subscribers receive the best possible quality, and thereby has some value. In either case, it is necessary to ensure that the symbol that is degraded does not contain customer bits or that the probability of causing an uncorrectable error is acceptably low.

A cable television network may be used to provide bidirectional voice communication, similarly to the public telephone network. In this case, the subscriber's telephone instrument is not connected to the public telephone network but is connected through a suitable adapter to the television cable network. The adapter digitizes the subscriber's

outgoing voice message and employs it to modulate a carrier, and similarly detects and converts to analog form an incoming digitized voice message. The headend is connected to the telephone instrument of the other party to the call through  
5 another network, which might be the public telephone network or include another cable distribution system. In either case, voice messages are transmitted bidirectionally between the subscriber node and the headend over the cable network by digitizing the voice messages and modulating a carrier with  
10 the digitized voice messages. The test method described herein can be used for testing a transmission channel used for voice transmission by providing a diagnostic function in the equipment at the subscriber node. The diagnostic function may be added to the functions performed in the  
15 subscriber's telephone/cable adapter or may alternatively be provided by a separate diagnostic receiver.

Bidirectional voice transmissions tend to be bursty, but excessive latency in response may be objectionable to the user. Accordingly, test packets should only be used during  
20 transmission if they are short enough that they will not cause excessive latency. Alternatively, since voice transmissions tend to be relatively short and have a protocol for starting and finishing each transmission session, test packets may be sent when setting up a call, tearing down a  
25 call, or during idle times.

FIG. 5 illustrates schematically a public telephone network including a node 110, such as a central office or fiber node, and subscriber lines 114 extending from the central node 110 to respective subscriber nodes 118. Analog  
30 voice traffic may be carried on the lines 114. Digital data may also be transmitted over the subscriber lines. For example, the central node may be connected to an internet service provider and provide for data transmission between a subscriber node and the ISP. In accordance with an xDSL  
35 protocol, such as ADSL (asynchronous digital subscriber line), the digital data is used to modulate one or more carriers, each having a frequency outside the audio range and

the digital data can then be transmitted concurrently with the analog voice traffic. In this case, the central node includes an xDSL transceiver and the subscriber node also includes an xDSL transceiver, for transmitting data between  
5 the central node and the subscriber node using the ADSL protocol.

The invention may be used to test the subscriber lines 114 to ensure that the digital data can be transmitted error free. At the subscriber node, the xDSL transceiver includes,  
10 or is provided with, a diagnostic receiver which operates similarly to the diagnostic cable receiver illustrated in FIG. 3. This provides a technique for detecting impairments in the transmission channel from the central node to individual subscriber nodes before the transmission channel  
15 is degraded to such an extent that error protected data packets cannot be recovered at the subscriber node. The other functions described with reference to FIGS. 3 and 4, such as transmission of messages to a central location and remote classification of impairments, apply to the system  
20 described with reference to FIG. 5.

In the case of data transmission, it is much simpler to include impaired packets in the transmission because data transmissions are usually bursty. By using a broadcast  
25 protocol, many subscriber lines can be tested in parallel by sending test packets to all subscriber nodes simultaneously. When testing an individual subscriber line, it is necessary to control operation of the impairments generator to ensure that the packet address will not be impaired, so that the subscriber node can correctly identify a packet intended for  
30 it. Rather, only the data inside the packet should be impaired.

It will be appreciated that the invention is not restricted to the particular embodiments that have been described, and that variations may be made therein without  
35 departing from the scope of the invention as defined in the appended claims and equivalents thereof. For example, although the description of FIGS. 3 and 4 refers to the

return path from the subscriber node 50 to the headend 48 as being the cable that is used for transmission from the headend to the subscriber node, it may instead be implemented by another medium, such as the public switched telephone  
5 network.



Claims

1. A method of operating a digital data distribution network having a transmitter and a receiver, wherein digital data is transmitted in error protected packets from the transmitter to the receiver over a transmission path by employing the digital data to modulate at least one carrier and impressing the modulated carrier on the network, said method comprising:
- (a) generating an error protected data packet for transmission over the transmission path,
  - (b) impairing the transmission path to a selected extent upstream of a transmission path segment that is to be tested,
  - (c) transmitting the data packet over the transmission path,
  - (d) receiving the data packet at the receiver, and
  - (e) determining whether the received data packet is error free.
2. A method according to claim 1, further comprising, if the transmission path is not error free, transmitting a message from the receiver to the transmitter.
3. A method according to claim 1, wherein step (c) comprises progressively increasing the extent to which the transmission path is impaired.
4. A method according to claim 1, wherein the network has a plurality of receivers and digital data is transmitted to the receivers over respective transmission paths, step (b) comprises transmitting the data packet to the receivers over the respective transmission paths, step (d) comprises receiving the data packet at each receiver, and step (e) comprises determining at each receiver whether the received data packet is error free.
5. A method according to claim 4, further comprising, if the transmission path to a selected receiver is not error

free, transmitting a message from the selected receiver to the transmitter, and analyzing messages received at the transmitter.

5           6.    A method according to claim 4, wherein the method comprises detecting receivers that report higher than average error rates and comparing the transmission paths to the respective receivers in a manner such as to derive information from the receivers that report higher than  
10 average error rates.

          7.    A method according to claim 4, wherein step (c) comprises progressively increasing the extent to which the transmission path is impaired and the method further  
15 comprises:

          transmitting a message from a receiver to the transmitter if the transmission path to that receiver is not error free, and

          correlating messages received at the transmitter with  
20 the extent to which the transmission path is impaired.

          8.    A method of operating a digital data distribution network having a transmitter and a receiver, wherein digital data is transmitted in error protected packets from the transmitter to the receiver over a transmission path by  
25 employing the digital data to modulate at least one carrier and impressing the modulated carrier on the network, said method comprising:

          (a) generating an error protected data packet for  
30 transmission over the transmission path,

          (b) transmitting the data packet over the transmission path as an analog signal,

          (c) receiving the analog signal at the receiver,

          (d) recording the analog signal received at the  
35 receiver, and

          (e) transmitting the record of the analog signal to a remote location for analysis.

9. A method according to claim 8, wherein step (e) comprises transmitting the record of the analog signal to the transmitter for analysis.

5 10. A method according to claim 8, wherein step (d) comprises digitizing the analog signal and the method further comprises deriving digital data from the digitized signal, forming a data packet from the digital data derived from the digitized signal, transmitting the data packet to the  
10 transmitter as an analog signal, digitizing the analog signal received at the transmitter, and processing the digitized signal at the transmitter.

11. A method according to claim 10, wherein the step of  
15 processing the digitized signal at the transmitter comprises deriving the error vector waveform for the transmission path to the receiver.

12. A method according to claim 8, wherein the network  
20 has a plurality of receivers and digital data is transmitted to the receivers over respective transmission paths, step (d) comprises digitizing the analog signal at each receiver, and the method further comprises deriving digital data from the digitized signal at each receiver, forming data packets at  
25 the respective receivers from the digital data derived from the digitized signal at each receiver, transmitting the data packets to the transmitter as analog signals, digitizing the analog signals received at the transmitter, and processing the digitized signals at the transmitter, and the step of  
30 processing the digitized signal at the transmitter comprises deriving the error vector waveforms for the transmission paths to at least first and second receivers and deriving the correlated error vector function for the transmission paths to the first and second receivers.

35 13. A method according to claim 8, wherein the network has a plurality of receivers and digital data is transmitted

to the receivers over respective transmission paths, and the method comprises deriving digital data from the digitized signal at each receiver, transmitting the digital data to the transmitter, and analyzing data received from multiple  
5 receivers to extract the locations of uncorrelated impairments.

14. A method according to claim 8, comprising  
processing the digitized signal to classify an impairment in  
10 the transmission path and testing the transmission margin of the transmission path with respect to the impairment by impairing the transmission path using that impairment.

15. A method according to claim 8, further comprising  
15 impairing the transmission path to a selected extent upstream of a transmission path segment to be tested.

16. A method of operating a digital data distribution network having a transmitter and a receiver, wherein digital  
20 data is transmitted in error protected packets from the transmitter to the receiver over a transmission path by employing the digital data to modulate at least one carrier and impressing the modulated carrier on the network, said method comprising:

25 generating an error protected data packet for transmission over the transmission path,  
impairing the transmission path to a selected extent upstream of a transmission path segment that is to be tested,  
transmitting the data packet over the transmission path,  
30 receiving the data packet at the receiver, and counting bit errors in the received data packet.

17. A method of operating a digital data distribution network having a transmitter and a receiver, wherein digital  
35 data is transmitted in error protected packets from the transmitter to the receiver over a transmission path by employing the digital data to modulate a carrier and

impressing the modulated carrier on the network, said method comprising:

(a) generating an error protected data packet for transmission over the transmission path,

5 (b) impairing the transmission path to a selected extent upstream of a transmission path segment that is to be tested,

(c) transmitting the data packet over the transmission path as an analog signal, and

(d) receiving the analog signal at the receiver.

10

18. A method according to claim 17, wherein the step of impairing the transmission path comprises impairing the transmission path by reducing its signal-to-noise ratio.

15

19. A method according to claim 17, wherein the step of impairing the transmission path comprises impairing the transmission path by reducing its frequency response.

20

20. A method according to claim 17, wherein the step of impairing the transmission path comprises impairing the transmission path by reducing its phase response.

25

21. A method according to claim 17, wherein the step of impairing the transmission path comprises impairing the transmission path by reducing its impulse response.

30

22. A method according to claim 17, wherein the step of impairing the transmission path comprises impairing the transmission path by introducing phase noise or jitter.

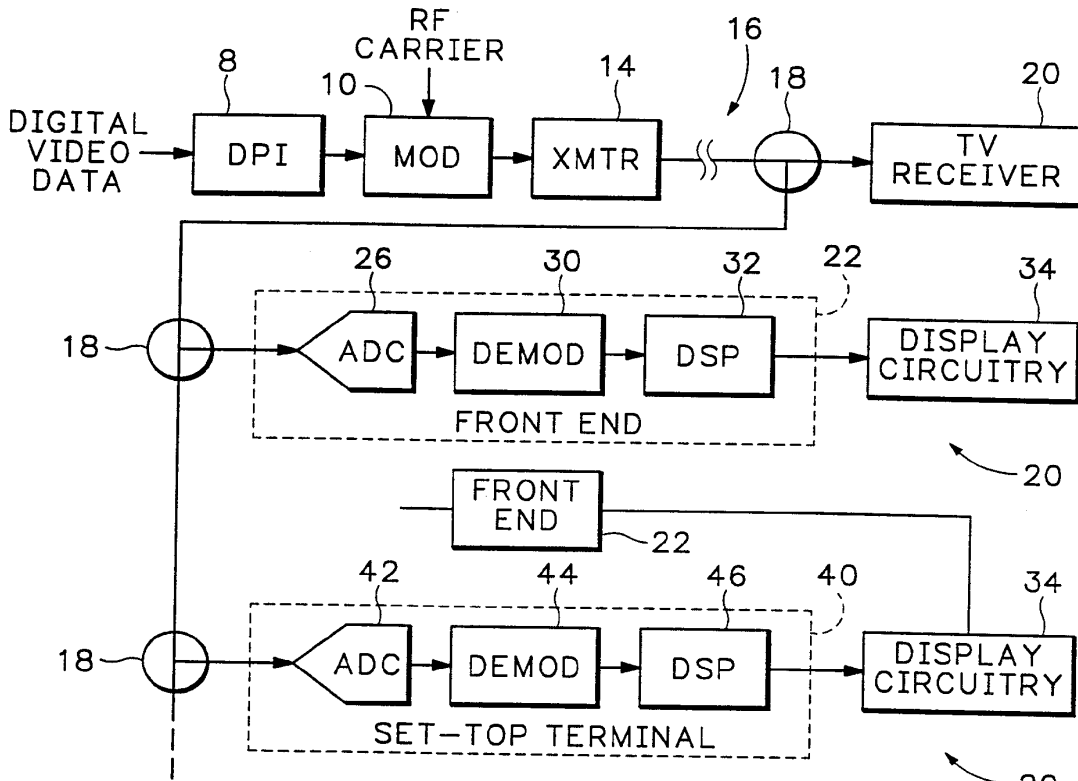

FIG.1

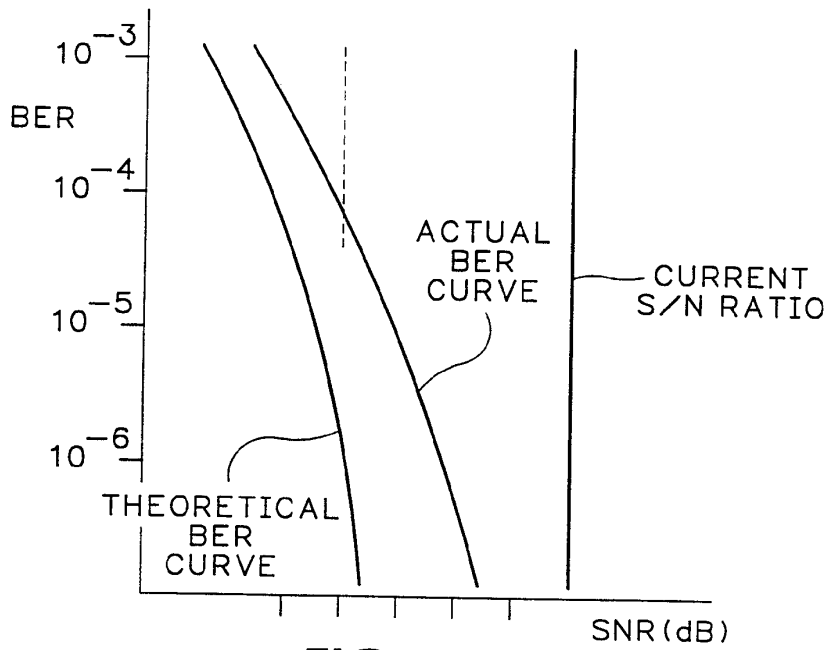
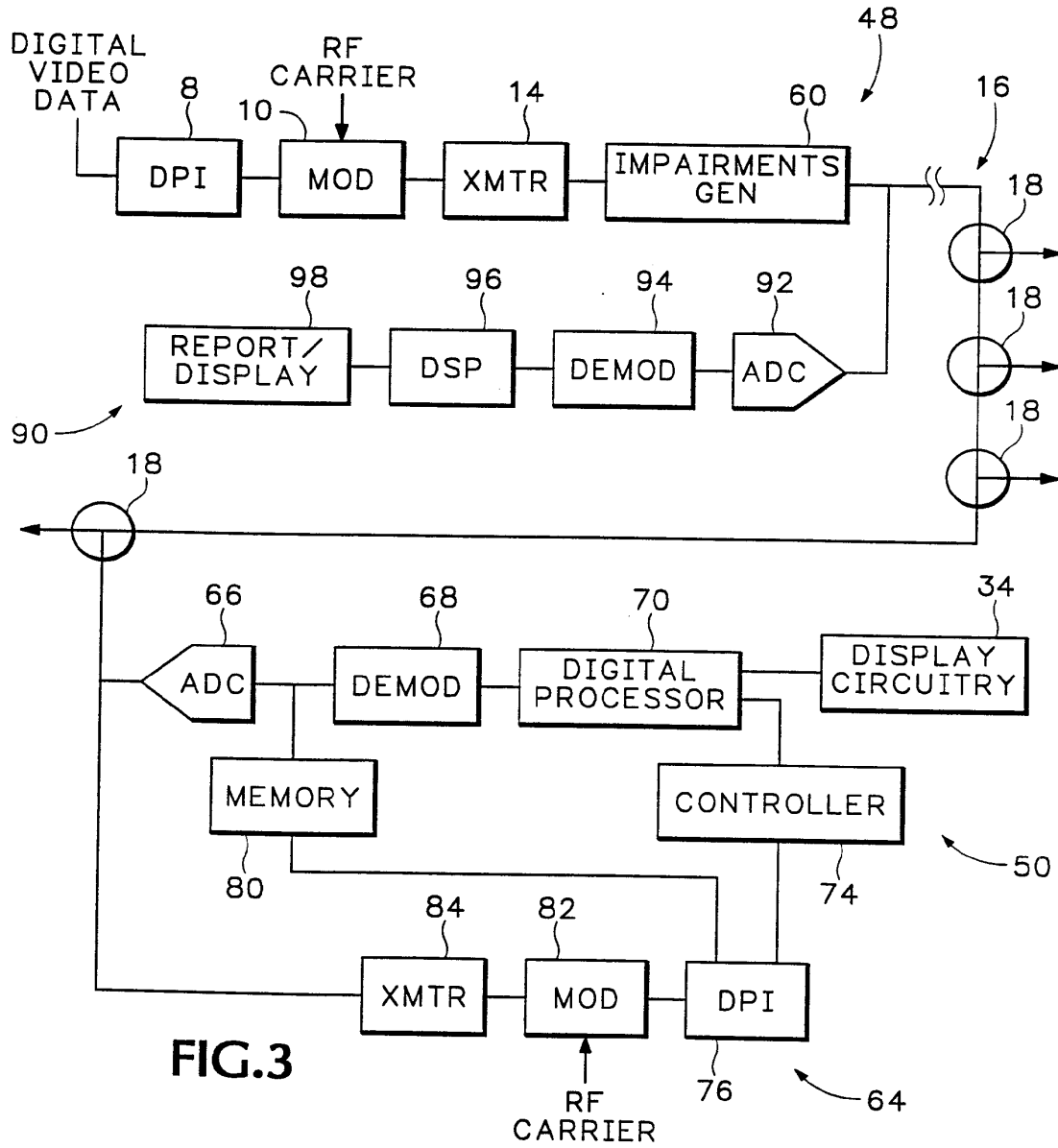
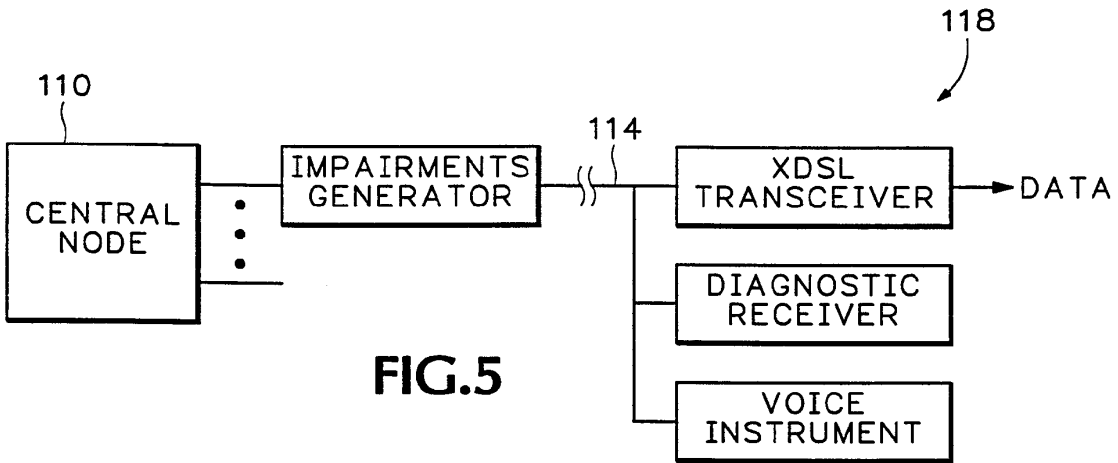
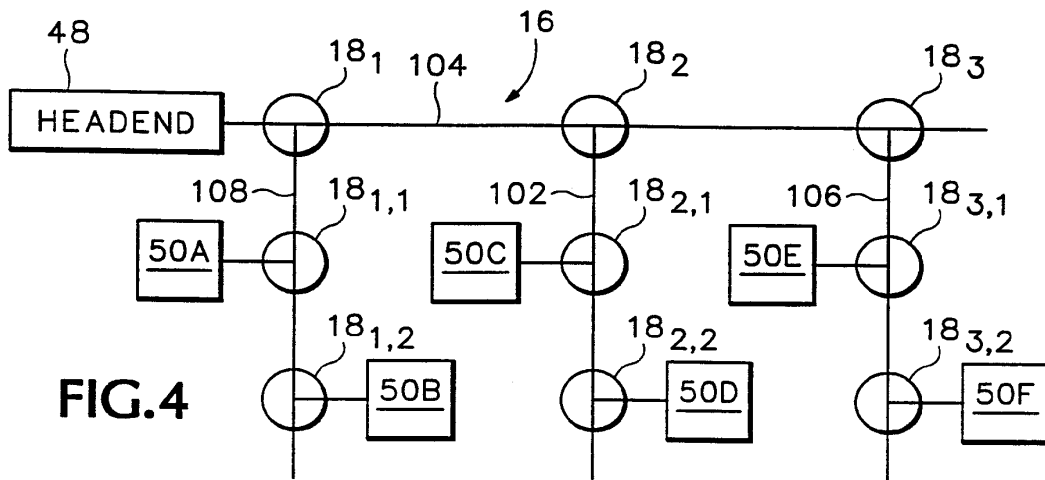

FIG.2









INTERNATIONAL APPLICATION PUBLISHED UNDER THE PATENT COOPERATION TREATY (PCT)

<p>(51) International Patent Classification <sup>6</sup> : <b>G06F 9/00, H04B 3/23, 3/32</b></p>	<p><b>A1</b></p>	<p>(11) International Publication Number: <b>WO 99/63427</b> (43) International Publication Date: 9 December 1999 (09.12.99)</p>
<p>(21) International Application Number: PCT/US99/11052 (22) International Filing Date: 19 May 1999 (19.05.99) (30) Priority Data: 09/086,386 29 May 1998 (29.05.98) US (71) Applicant: GTE LABORATORIES INCORPORATED [US/US]; 1209 Orange Street, Wilmington, DE 19801 (US). (72) Inventors: EICHEN, Elliot; 41 Mary Street, Arlington, MA 02174 (US). BROOKS, David, L.; 11 Vose Hill Road, Maynard, MA 01754 (US). (74) Agents: SUCHYTA, Leonard, Charles et al.; GTE Service Corporation, 600 Hidden Ridge, MC HQE03G13, Irving, TX 75038 (US).</p>	<p>(81) Designated States: AE, AL, AM, AT, AU, AZ, BA, BB, BG, BR, BY, CA, CH, CN, CU, CZ, DE, DK, EE, ES, FI, GB, GD, GE, GH, GM, HR, HU, ID, IL, IN, IS, JP, KE, KG, KP, KR, KZ, LC, LK, LR, LS, LT, LU, LV, MD, MG, MK, MN, MW, MX, NO, NZ, PL, PT, RO, RU, SD, SE, SG, SI, SK, SL, TJ, TM, TR, TT, UA, UG, UZ, VN, YU, ZA, ZW, ARIPO patent (GH, GM, KE, LS, MW, SD, SL, SZ, UG, ZW), Eurasian patent (AM, AZ, BY, KG, KZ, MD, RU, TJ, TM), European patent (AT, BE, CH, CY, DE, DK, ES, FI, FR, GB, GR, IE, IT, LU, MC, NL, PT, SE), OAPI patent (BF, BJ, CF, CG, CI, CM, GA, GN, GW, ML, MR, NE, SN, TD, TG).</p> <p><b>Published</b> <i>With international search report.</i></p>	

(54) Title: METHOD AND APPARATUS FOR DIGITAL SUBSCRIBER LOOP QUALIFICATION

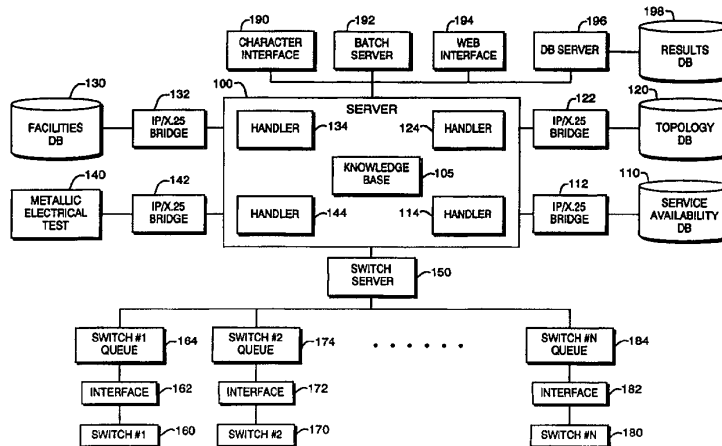

(57) Abstract

A system and methodology for qualifying a twisted pair copper loop for digital subscriber loop services are described. The system automatically queries telecommunications provider database records and/or requests measurements from network switching equipment or testing systems to obtain data regarding the twisted pair copper loop, such as loop length, electrical characteristics, and other loop topology characteristics such as wire gauge, the presence of load coils (88, 90), and the presence of bridge taps (84, 86). The system determines which digital subscriber loop services are available for the copper loop based on the combination of all data obtained. The system may be implemented in part as an expert system with a knowledge base of qualification rules used in the decision-making process.

**FOR THE PURPOSES OF INFORMATION ONLY**

Codes used to identify States party to the PCT on the front pages of pamphlets publishing international applications under the PCT.

AL	Albania	ES	Spain	LS	Lesotho	SI	Slovenia
AM	Armenia	FI	Finland	LT	Lithuania	SK	Slovakia
AT	Austria	FR	France	LU	Luxembourg	SN	Senegal
AU	Australia	GA	Gabon	LV	Latvia	SZ	Swaziland
AZ	Azerbaijan	GB	United Kingdom	MC	Monaco	TD	Chad
BA	Bosnia and Herzegovina	GE	Georgia	MD	Republic of Moldova	TG	Togo
BB	Barbados	GH	Ghana	MG	Madagascar	TJ	Tajikistan
BE	Belgium	GN	Guinea	MK	The former Yugoslav Republic of Macedonia	TM	Turkmenistan
BF	Burkina Faso	GR	Greece	ML	Mali	TR	Turkey
BG	Bulgaria	HU	Hungary	MN	Mongolia	TT	Trinidad and Tobago
BJ	Benin	IE	Ireland	MR	Mauritania	UA	Ukraine
BR	Brazil	IL	Israel	MW	Malawi	UG	Uganda
BY	Belarus	IS	Iceland	MX	Mexico	US	United States of America
CA	Canada	IT	Italy	NE	Niger	UZ	Uzbekistan
CF	Central African Republic	JP	Japan	NL	Netherlands	VN	Viet Nam
CG	Congo	KE	Kenya	NO	Norway	YU	Yugoslavia
CH	Switzerland	KG	Kyrgyzstan	NZ	New Zealand	ZW	Zimbabwe
CI	Côte d'Ivoire	KP	Democratic People's Republic of Korea	PL	Poland		
CM	Cameroon	KR	Republic of Korea	PT	Portugal		
CN	China	KZ	Kazakstan	RO	Romania		
CU	Cuba	LC	Saint Lucia	RU	Russian Federation		
CZ	Czech Republic	LI	Liechtenstein	SD	Sudan		
DE	Germany	LK	Sri Lanka	SE	Sweden		
DK	Denmark	LR	Liberia	SG	Singapore		
EE	Estonia						

## METHOD AND APPARATUS FOR DIGITAL SUBSCRIBER LOOP QUALIFICATION

### 5 Technical Field

The present invention relates to digital subscriber loop technology and, more specifically, to the qualification of existing twisted pair copper loops for digital subscriber loop service.

### Background Art

10 Digital subscriber loop technology is the digital encoding of all information transmitted on the local loop, *i.e.*, the connection between a customer's premises (home, office, etc.) and a telecommunications provider's central office serving the customer's premises. Most existing local loops in the United States and throughout the world are twisted pair copper loops, originally designed for analog service, or  
15 plain old telephone service (POTS). With digital subscriber loop technology, high speed access to the Internet, advanced telephony functions, and multimedia services is possible over the twisted pair copper access network. Digital subscriber systems can provide data from speeds of 64 kb/second in both upstream and downstream directions to over 10 Mb/second in a single direction. Digital subscriber loop  
20 technology, often referred to as "xDSL" where x stands for any of a number of letters, includes the following:

ADSL, Asymmetric Digital Subscriber Loop

VDSL, Very High-Speed Digital Subscriber Loop

HDSL, High Data Rate Digital Subscriber Loop

25 SDSL, Symmetric Digital Subscriber Loop

IDSL, ISDN-based Digital Subscriber Loop

RADSL, Rate Adaptive Digital Subscriber Loop

ISDN, Integrated Digital Service Network

Some of these digital subscriber loop technologies (*e.g.*, HDSL, ISDN, and in  
30 particular ADSL) have been standardized by various standards bodies with respect to modulation format, bandwidth, and embedded operations channels, while others have not been standardized and are available from different vendors in a wide

variety of modulation formats, upstream/downstream bandwidths, and operation channels.

As illustrated in Figure 1, digital subscriber loop technology consists of two terminal endpoints (TEs) 10 and 20, which provide conversion, modulation, transmission, and reception of data, and copper loop 30 connecting TEs 10 and 20. TE 10 is typically owned and operated by the service provider, while TE 20 is typically at the customer's premises. In the United States, TE 20 is typically owned or rented by the customer, while in most other parts of the world TE 20 is typically owned and operated by the service provider. In addition, the digital subscriber loop topology can include terminal equipment, such as a repeater, between the two terminal endpoints to provide additional network flexibility or to boost signal strength and transmission distances. For example, Figure 2 illustrates network terminal 70 in copper loop 60 between TEs 40 and 50.

Digital subscriber loop services, however, cannot be carried over all twisted pair copper loops that support POTS service. The various digital subscriber loop technologies have complex (real and imaginary) signal attenuation restrictions that depend upon downstream (to the customer) and upstream (from the customer) bandwidth, modulation format, and receiver sensitivity for a particular chip set used by a vendor terminal endpoint equipment. Signal attenuation itself depends on several factors, including the length and gauge of the copper wires contained in the loop, the environment in which the copper wires are placed (including temperature variations), and the quality of connections (*e.g.*, splices and terminal connections) that attach the different sections of wire contained in a given loop. Digital subscriber loop technologies also have restrictions on loop topology, such as the position and number of bridge taps and load coils, and restrictions on services provided in adjacent copper pairs in the same binder group (*i.e.*, a group of twisted pairs bundled together) because of crosstalk between pairs and overlapping frequency spectrums.

Figure 3 illustrates a typical copper loop between central office (CO) 80 and terminal endpoint 82, made up of several different lengths of wire of different gauges spliced together. One leg of the loop terminates at terminal endpoint 82,

while two other legs are unterminated, resulting in bridge taps 84 and 86. The loop in Figure 3 also includes two load coils, 88 and 90, as well as cross connect 92.

As an example of loop topology requirements, a loop is restricted to less than approximately 5.25 km of 24 gauge wire when the digital service is provided at the rate of 1.5 Mb/second downstream and 80 kb/second upstream for a commonly available chip set that uses carrierless amplitude phase (CAP) modulation for ADSL. For this modulation format and bandwidth allocation, if there is an analog carrier POTS service in the same wire binder group, the ADSL modulation will interfere with the analog carrier, effectively destroying the POTS service. Similarly, if there is a T1 carrier system in the same wire binder group, the T1 service will interfere with the ADSL modulation, nullifying the digital subscriber service, but typically not affecting the T1 service. The number of copper pairs and the potential for crosstalk in a binder group depends on the type and manufacturer of the copper cable.

Today, when a customer wishes to order a digital subscriber loop service, the local telecommunications service provider must determine whether the customer's existing twisted pair copper loop can support the requested digital subscriber loop service at the desired bandwidth. This can be a difficult and time-consuming task to perform manually because of the many restrictions on loop topology and services just described. All necessary data may not be available to a person trying to qualify a loop for digital subscriber loop services, particularly because telecommunications providers often have data in many different databases or stored in paper records. Even if data is available, data concerning outside plant information such as loop length and topology is often out of date. Also, certain metallic loop electrical data is not stored in a database and can only be determined by a measurement or test system.

It is desirable, therefore, to provide a system and methodology for determining which digital subscriber loop technologies can be supported by a particular twisted pair copper loop. It is more desirable to qualify a copper loop for digital subscriber loop services on the basis of real-time electrical measurements as well as records stored in telecommunications provider databases. It is even more desirable to provide an automated system for digital subscriber loop qualification

that economically determines which digital subscriber loop technologies can be supported by a copper loop. It is also desirable to implement such a system as an expert system containing a knowledge base of rules.

**Disclosure of Invention**

5           The present invention satisfies those desires by providing a system and methodology for qualifying a twisted pair copper loop for digital subscriber loop services. The system automatically queries telecommunications provider database records and/or requests measurements from network switching equipment or testing systems to obtain information regarding the twisted pair copper loop in question.

10          The system then determines which digital subscriber loop services are available for the copper loop based on the combination of all information obtained.

          A method consistent with the present invention for qualifying a twisted loop pair for a digital subscriber service comprises the steps of receiving as input a unique identifier corresponding to the loop, determining a topology corresponding to  
15          the loop, and determining whether the loop meets topology restrictions of the digital subscriber service. Another method consistent with the present invention comprises the steps of receiving data corresponding to physical characteristics of the loop and applying a plurality of rules to the data to determine whether the loop is suitable for the digital subscriber service. Other methods consistent determine whether electrical  
20          characteristics of the loop meet restrictions of the digital subscriber service and whether services provided on other cable pairs in the same binder group with the loop are compatible with the digital subscriber service.

          Systems are also provided for carrying out the methodologies of the present invention.

25          The advantages accruing to the present invention are numerous. A loop qualification system and method consistent with the present invention reduce the time for determining which digital subscriber loop services a particular copper loop supports from several hours to a few minutes. A system and method consistent with the present invention also provide a substantially more accurate result, in part  
30          because they use real-time electrical measurements to determine many topological characteristics of the copper loop.

The above desires, and other desires, features, and advantages of the present invention will be readily appreciated by one of ordinary skill in the art from the following detailed description of the preferred implementations when taken in connection with the accompanying drawings.

5 **Brief Description of Drawings**

Figure 1 illustrates digital subscriber loop technology connecting two terminal endpoints;

Figure 2 illustrates digital subscriber loop technology with network terminal equipment between two terminal endpoints;

10 Figure 3 illustrates a typical digital subscriber loop topology;

Figure 4 illustrates the architecture of a loop qualification system consistent with the present invention; and

Figure 5 is a flow chart of a method for qualifying loops consistent with the present invention.

15 **Best Mode for Carrying Out the Invention**

A system consistent with the present invention automatically qualifies twisted pair copper loops for digital subscriber loop services. Generally, a method for qualifying loops for digital subscriber loop services consistent with the present invention includes at least four types of qualification:

20 (1) Service Availability: Is the point at which the copper loop terminates equipped to provide the requested digital subscriber service?

(2) Length Qualification: Which digital subscriber loop services at which bandwidths can be provided given the length of the loop?

25 (3) Line Qualification: Is the loop physically suitable for use by a digital subscriber loop technology? Is the service currently provisioned on the loop compatible with digital subscriber loop service?

(4) Are the services provided on the other twisted pairs in the same binder group with the loop spectrally compatible with digital subscriber loop services?

30 In order to answer these loop qualification questions, a system consistent with the present invention combines results obtained from testing the copper loop, results from queries of telecommunications provider database records, and

information regarding the transmission and receiver characteristics of the digital subscriber.

Figure 4 illustrates the architecture of a system for qualifying loops consistent with the present invention, which may be implemented, for example, as an expert system using a conventional client-server architecture known in the art. The expert system is implemented in software residing on server 100 and performs loop qualification by combining input from a number of information sources with rules contained in knowledge base 105. Specifically, server 100 obtains information from service availability database 110, topology database 120, facilities database 130, and metallic electrical test system 140. Databases 110, 120, and 130, and test system 140 are typically owned and operated by the local telecommunications provider. It will be recognized by one skilled in the art that each database shown in Figure 4 may actually consist of several smaller databases or, alternatively, that databases may be combined, since each telecommunications provider organizes its data into databases in different ways. Server 100 interfaces to the databases and test system via a suitable communications protocol such as IP or X.25, provided by interfaces 112, 122, 132, and 142. Server 100 additionally includes software handler modules for receiving and processing information obtained from databases 110, 120, and 130, and test system 140.

Server 100 also receives information and test results directly from central office switches in the local network, three of which are shown in Figure 4 as switches 160, 170, and 180 for illustrative purposes. Server 100 is coupled to switch server 150, which is coupled to switch queues 164, 174, and 184, corresponding to switches 160, 170, and 180, respectively. Switch queues 164, 174, and 184 access data from switches 160, 170, and 180 via interfaces 162, 172, and 182, respectively. It will be recognized by one skilled in the art that switch server 150 need not be separate from server 100.

Consistent with the present invention, a user may access server 100 through either the graphical user interface of client 194, *e.g.*, a World Wide Web-based client, or character interface 190, *e.g.*, a VT100 character interface. Regardless of the interface used, a user will typically enter a unique number (*e.g.*, a telephone directory number (TDN) or an IP address) or identifier (*e.g.*, a circuit identifier)



associated with the copper loop for which qualification is desired. A system consistent with the present invention also includes batch server 192, which allows qualification of numerous loops to be performed in batch, and database server 196 for storing results in results database 198.

5           Figure 5 is a flow chart illustrating a method for qualifying loops for digital subscriber loop services consistent with the present invention. Consistent with an embodiment of the present invention, the method is performed by software residing on server 100. The process begins by receiving as input a unique identifier corresponding to the copper loop to be qualified for digital subscriber services (step  
10 200). The unique identifier may be a telephone directory number (TDN) as shown in Figure 5, or any other unique identifier such as an IP address or a circuit identifier. Also, server 100 may receive the identifier from any input source, including character interface 190 or web interface 194 (if a human user is accessing the system through an interface) and batch server 192 (if several qualification  
15 requests have been entered for batch processing). Most of the remaining steps in the process use the unique loop identifier to retrieve information regarding the loop.

Once receiving a loop identifier, the qualification process continues by determining whether digital subscriber loop services are available for the loop (step 210). Consistent with the present invention, the server makes this determination by  
20 querying service availability database 110 to determine whether the local telecommunications provider provides xDSL services from the office serving the customer's location. If xDSL service is not available, loop qualification terminates. If xDSL service is available, processing continues to step 220. In an alternate method consistent with the present invention, the server may choose to continue the  
25 loop qualification process although xDSL service is not available.

Next, the process determines whether the loop is on a working pair (step 220) by querying facilities database 130. Some measurement tests performed by a loop qualification method consistent with the present invention require that the loop be on a working pair. If the loop is not on a working pair, the server either  
30 terminates loop qualification (as shown in Figure 5) or chooses to continue loop qualification, although not all tests will be available for the loop. Alternatively, the

loop may be temporarily assigned to line equipment and a test number so that loop qualification may be performed.

If loop qualification continues, the server determines whether the current service on the loop is compatible with xDSL service (step 230). For example, in the United States the current service cannot be T1 or ISDN. Consistent with the present invention, the server performs this step by querying facilities database 130. As discussed above, it should be apparent to one skilled in the art that, although the queries in steps 220 and 230 both access databases with information regarding facilities, the facilities database shown in Figure 4 (database 130) may consist of several smaller databases, so that the queries of steps 220 and 230 access two different, smaller databases. If the current service is not compatible, loop qualification ends. If the current service is compatible, then flow proceeds to several data collection steps. In an alternate method consistent with the present invention, the server may choose to continue the loop qualification process although the current service is not compatible with xDSL service.

A method consistent with the present invention performs some or all of data collection steps 240, 250, 260, and 270. These steps are not necessarily performed in a particular order, and some steps may be performed simultaneously. For example, Figure 5 shows steps 240 and 250 being performed at the same time as steps 260 and 270. Each of these steps involves obtaining information about the loop to be qualified from a database or a test or measurement system in the network, and all of the information obtained is used as input to step 280, which applies a plurality of rules to the information to model the response of the network and determine which digital subscriber services are available on the loop.

In step 240, the server queries topology database 120 using the unique loop identifier (*e.g.*, TDN or IP address) to obtain a variety of loop topology data. In particular, the server requests length and gauge of wire on the loop for each loop segment, cable type, the location of load coils on the loop, and the location and length of bridge taps on the loop. For example, the loop topology shown in Figure 3 is an example of data that may be obtained from topology database 120. As described above, topology database 120 may consist of several smaller databases, each of which contains different information. Step 240 may also include a query of

a separate database (not shown in Figure 4) that stores recent measurements of the loop length. This data may be more accurate than a topology database operated by the telecommunications provider for storing many different types of loop topology data.

5 Referring again to Figure 5, in step 250 the server queries facilities database 130 using the unique loop identifier to determine the services on other cable pairs in the same binder group as the loop to be qualified. This information will be used in step 280 to determine whether xDSL services are spectrally compatible with the services on the other cable pairs in the binder so that crosstalk will not degrade  
10 service quality.

In step 260, the server requests measurements from metallic electrical test system 140, which is a remote test system such as 4TEL, manufactured by Teradyne, Inc., or Mechanized Loop Test (MLT), manufactured by Lucent Technologies. Consistent with the present invention, the server requests a measure  
15 of loop length and/or loop capacitance, which can be converted to loop length using a known mathematical relationship. The server also requests measures of longitudinal balance and wideband and narrowband electrical ingress which will be used in step 280 to determine the suitability of the loop for digital subscriber loop services. As described earlier, tests in step 260 may not be performed if the loop is  
20 not on a working pair.

In step 270, the server requests a load coil detection measurement to determine if there are any load coils in the loop. This measurement can be performed at the end office switch at which the loop terminates (*e.g.*, switch 160, 170, or 180 in Figure 4) or by metallic electrical test system 140. If the server  
25 obtains the measurement from the switch, switch server 150 receives measurements from queues 164, 174, and 184, and controls server 100's access to switch measurements. Examples of load coil detection measurements known in the art are a swept frequency measurement and a time domain reflectometry measurement. As described earlier, tests in step 270 may not be performed if the loop is not on a  
30 working pair.

All of the information obtained in steps 240, 250, 260, and 270 from database queries and test and measurement systems is input to step 280. Consistent

with the present invention, in step 280 an expert system resident on server 100 combines the results of steps 240, 250, 260, and 270 with a plurality of qualification rules from knowledge base 105 and information on network equipment stored in a database (not shown for the sake of clarity) to model the response of the network for the various digital subscriber loop services available to the subscriber. The expert system also determines, for each of the available digital subscriber loop services (*e.g.*, ADSL, VDSL, etc.), how much bandwidth can be supported in both upstream and downstream directions.

Consistent with the present invention, the qualification rules in knowledge base 105 are not limited to any particular set. The rules may range from the simple (*e.g.*, a loop with one or more load coils does not qualify for a digital subscriber loop service) to the more complex (*e.g.*, for a certain type of terminal equipment and a particular digital subscriber loop service with given upstream and downstream bandwidth, a combination of wire length and gauge limits can be calculated according to mathematical relationships to satisfy given signal attenuation and/or bit error rate requirements).

Consistent with the present invention, there may be a conflict between data retrieved from a database and data measured in real-time using a measurement system or test system. In such cases, knowledge base 105 can also include rules for reconciling the differences. For example, if data retrieved from a database is known not to have been updated recently, then a qualification method consistent with the present invention would rely on measured data, which may be more accurate.

The ultimate output of a system consistent with the present invention is a list of digital subscriber loop service packages that the loop can support. For a particular type of xDSL service (*e.g.*, ADSL), there may be multiple packages, each of which defines a different class of service, including upstream and downstream bandwidth. For example, a loop may be able to support an ADSL package with downstream/upstream bit rates of 640k/272k, but the same loop may not support ADSL with bit rates of 640k/680k because of the loop length and topology. Alternatively, a system consistent with the present invention may determine whether a loop can support a specified digital subscriber loop service with given upstream and downstream bandwidths. In this case, the system user may enter the service

type and bandwidth desired. In addition to simply listing qualified services, the system may provide the user with diagnostic information explaining why a particular decision was reached.

It will be apparent to those skilled in this art that various modifications and variations can be made to the loop qualification scheme of the present invention without departing from the spirit and scope of the invention. Other embodiments of the invention will be apparent to those skilled in this art from consideration of the specification and practice of the invention disclosed herein. In particular, the method is not limited to implementation in a client/server architecture or as an expert system. Nor is the invention limited to the user interfaces described. For example, a machine application program interface can provide access to the system from another system or as part of a larger provisioning system. A method consistent with the present invention can also be used to qualify loops for other services whose qualification requires access to database and/or real-time measurements. It is intended that the specification and examples be considered exemplary only, with the true scope and spirit of the invention being indicated by the following claims.

**Claims**

1. A method for qualifying a twisted pair loop for a digital subscriber service having loop topology restrictions, the method comprising the steps of:  
receiving a unique identifier corresponding to the loop;  
5 identifying a topology corresponding to the identified loop; and  
determining whether the identified loop meets the loop topology restrictions of the digital subscriber service based on the identified topology.
2. The method of claim 1 further including the step of computing a bandwidth that can be supported on the loop in response to the topology.
- 10 3. The method of claim 1 wherein the identifying step includes the substeps of determining a length corresponding to the loop and determining a gauge corresponding to the loop.
4. The method of claim 3 wherein the substep of determining a length includes the substeps of requesting a capacitance measurement of the loop from a  
15 metallic electrical testing system and converting the capacitance measurement into the length.
5. The method of claim 3 wherein the substep of determining a length includes the substep of requesting a length measurement from a metallic electrical testing system.
- 20 6. The method of claim 3 wherein the substep of determining a length includes the substep of querying a database containing a recent length measurement of the loop.
7. The method of claim 3 wherein the substep of determining a length includes the substep of querying a database containing a known length of the loop.
- 25 8. The method of claim 3 wherein the substep of determining a gauge includes the substep of querying a topology database containing the gauge of the loop.
9. The method of claim 1 wherein the loop contains a plurality of loop segments, and wherein the identifying step includes the substeps of determining a  
30 length corresponding to each of the plurality of loop and segments and determining a gauge corresponding to each of the plurality of loop segments.

10. The method of claim 9 wherein the substep of determining a length includes the substep of querying a database containing the length of each of the plurality of loop segments.

5 11. The method of claim 9 wherein the substep of determining a gauge includes the substep of querying a database containing the gauge of each of the plurality of loop segments.

12. The method of claim 1 wherein the identifying step includes the substep of querying a database for the position of a bridge tap in the loop.

10 13. The method of claim 1 wherein the identifying step includes the substep of querying a database for the length of a bridge tap in the loop.

14. The method of claim 1 wherein the identifying step includes the substep of querying a database for the number of bridge taps in the loop.

15 15. The method of claim 1 wherein the identifying step includes the substep of querying a database for the position of a load coil in the loop.

16. The method of claim 1 wherein the identifying step includes the substep of querying a database for the number of load coils in the loop.

17. The method of claim 1 wherein the identifying step includes the substeps of requesting a load coil measurement of the loop from a test system at a switch connected to the loop.

20 18. The method of claim 17 wherein the load coil measurement is a swept frequency measurement.

19. The method of claim 17 wherein the load coil measurement is a time domain reflectometry measurement.

25 20. A method for qualifying a twisted pair loop for a digital subscriber service, the method comprising the steps of:

receiving a unique identifier corresponding to the loop;

identifying a first cable pair and a binder corresponding to the identified loop having the first cable pair corresponding to the identified loop and a second cable pair; and

30 determining whether services provided on the second cable pair are compatible with the digital subscriber service.

21. The method of claim 20 wherein the identifying step includes the substep of querying a database correlating the binder to the first and second cable pairs and services provided on the cable pairs, and wherein the determining step includes the substep of querying the database.

5 22. A method for qualifying a twisted pair loop for a digital subscriber service, the method comprising the steps of:

receiving a unique identifier corresponding to the loop;  
identifying a current service on the identified loop; and  
determining whether the current service is compatible with the digital

10 subscriber service.

23. The method of claim 22 wherein the identifying step includes the substep of querying a database correlating the identifier to the current service on the loop.

24. The method of claim 22 further comprising the step of determining  
15 whether the identifier corresponds to a working loop.

25. A method for qualifying a twisted pair loop for a digital subscriber service having longitudinal balance restrictions, the method comprising the steps of:

receiving a unique identifier corresponding to the loop;  
requesting a longitudinal balance measurement of the identified loop from a  
20 metallic electrical testing system; and  
determining whether the measurement meets the restrictions.

26. A method for qualifying a twisted pair loop for a digital subscriber service having electrical ingress restrictions, the method comprising the steps of:

receiving a unique identifier corresponding to the loop;  
25 requesting an electrical ingress measurement of the identified loop from a metallic electrical testing system; and  
determining whether the measurement meets the restrictions.

27. A method for qualifying a twisted pair loop for a digital subscriber service, the method comprising the steps of:

receiving data corresponding to physical characteristics of the loop; and  
30 applying a plurality of qualification rules to the data to determine whether the loop is suitable for the digital subscriber service.



28. The method of claim 27 wherein the receiving step includes the substep of receiving data from a metallic loop electrical test system.

29. The method of claim 27 wherein the receiving step includes the substep of receiving data from a database.

5 30. The method of claim 27 wherein the receiving step includes the substep of receiving data from a switch connected to the loop.

31. The method of claim 27 wherein the applying step is performed by an expert system.

32. A method for qualifying a twisted pair loop for a telecommunications  
10 service, the method comprising the steps of:

receiving data corresponding to physical characteristics of the loop; and  
applying a plurality of qualification rules to the data to determine whether  
the loop is suitable for the telecommunications service.

33. The method of claim 32 wherein the applying step is performed by an  
15 expert system.

34. A system for qualifying a twisted pair loop for a digital subscriber  
service having loop topology restrictions, the system comprising:

an interface for receiving a unique identifier corresponding to the loop;  
means for identifying a topology corresponding to the identified loop; and  
20 means for determining whether the identified loop meets the topology  
restrictions of the digital subscriber service based on the identified topology.

35. The system of claim 34 wherein the identifying means includes  
means for querying a database.

36. The system of claim 34 wherein the identifying means includes  
25 means for requesting a measurement from a test system.

37. A system for qualifying a twisted pair loop for a digital subscriber  
service comprising:

means for receiving data corresponding to physical characteristics of the  
loop; and  
30 means for applying a plurality of qualification rules to the data to determine  
whether the loop is suitable for the digital subscriber service.

38. The system of claim 37 further wherein the means for applying includes an expert system, the expert system including a knowledge base containing the plurality of qualification rules.

39. A system for qualifying a twisted pair loop for a digital subscriber  
5 service having loop topology restrictions, said system comprising:  
an interface for receiving a unique identifier corresponding to the loop;  
a memory comprising a loop qualification program for identifying a topology  
corresponding to the identified loop, and for determining whether the identified loop  
meets the loop topology restrictions; and  
10 a processor for running the loop qualification program.

40. A system for qualifying a twisted pair loop for a digital subscriber  
service comprising:  
an interface for receiving data corresponding to physical characteristics of  
the loop;  
15 a memory comprising a knowledge base containing a plurality of rules, and a  
loop qualification program for applying the plurality of rules; and  
a processor for running the loop qualification program.

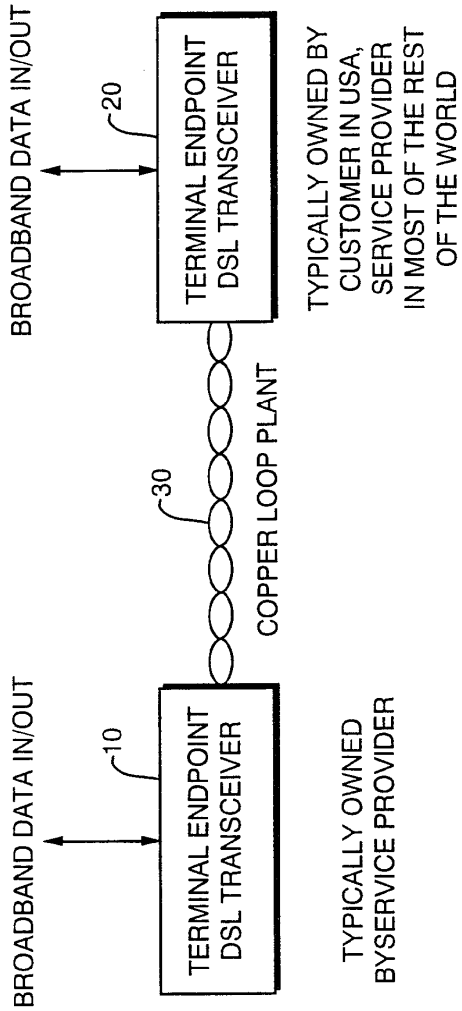

FIG. 1

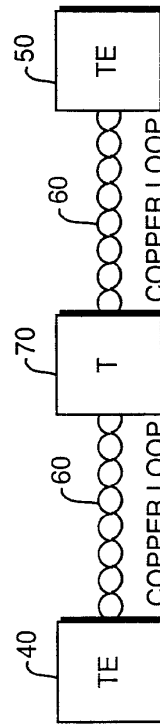

FIG. 2



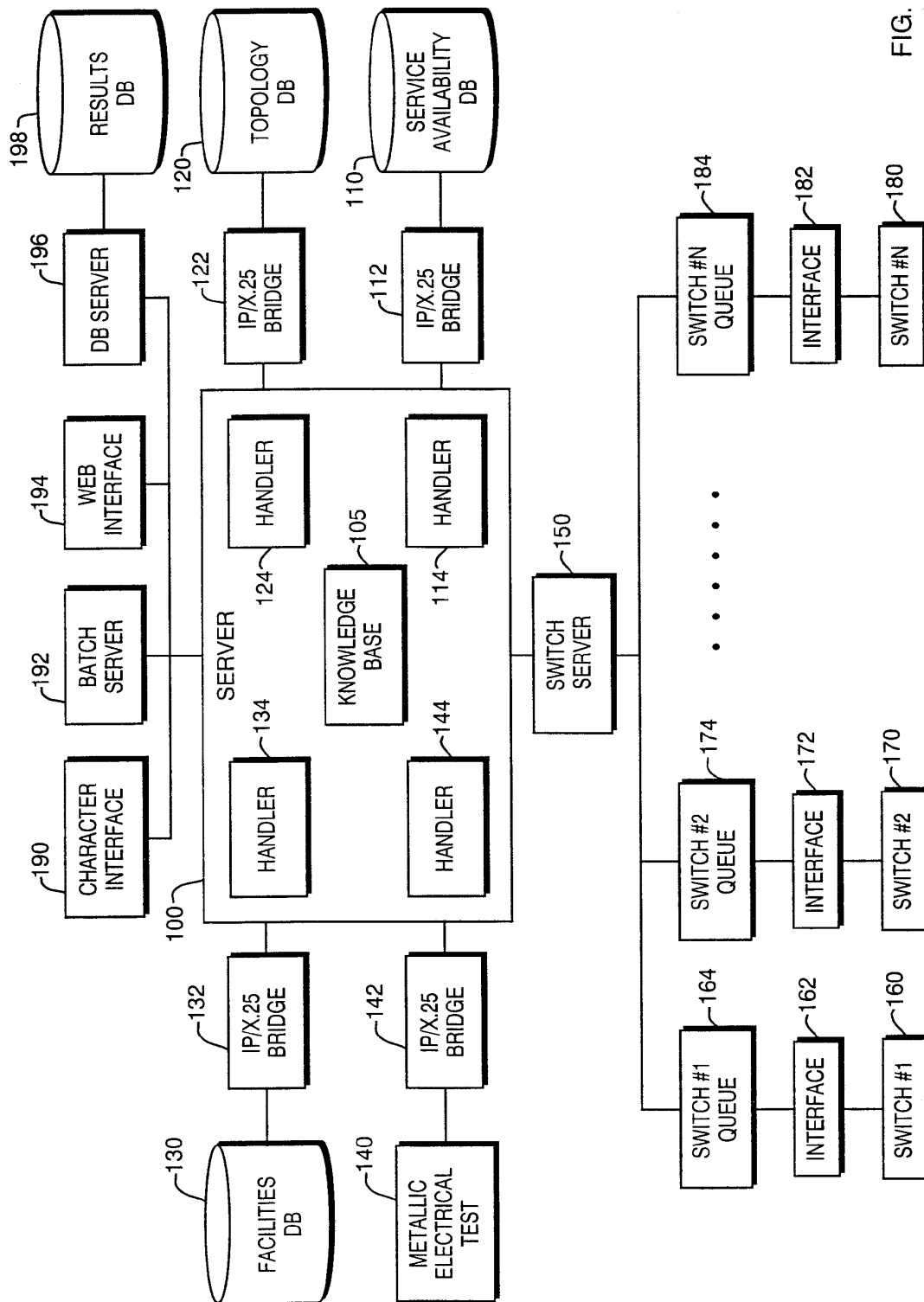

FIG. 4

4/4

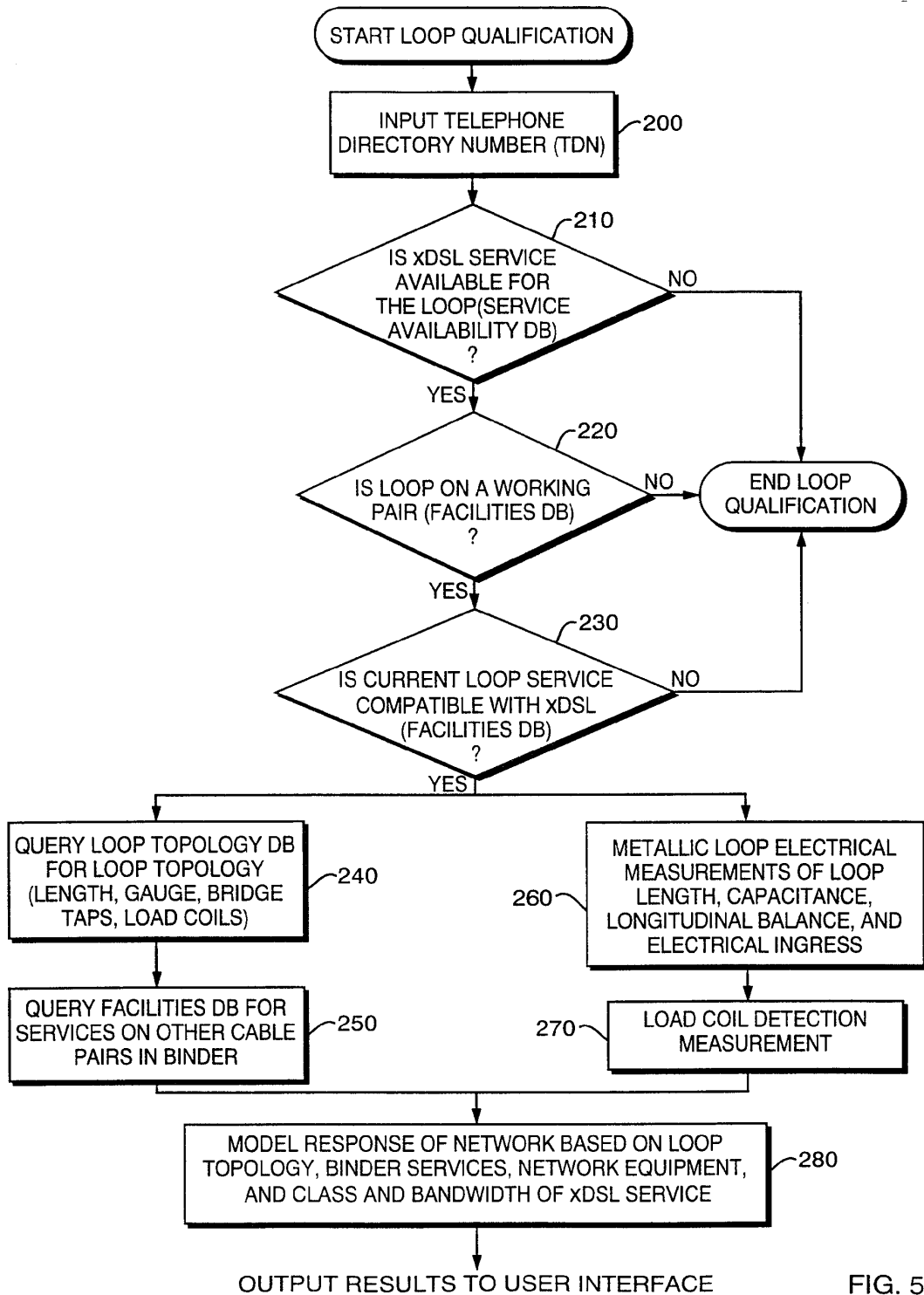
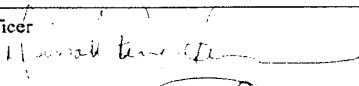

FIG. 5

INTERNATIONAL SEARCH REPORT

International application No.  
PCT/US99/11052

<b>A. CLASSIFICATION OF SUBJECT MATTER</b> IPC(6) : G06F 9/00; H04B 3/23, 3/32 US CL : 702/57; 370/286, 294, 401; 375/296, 346, 349; 364/141 According to International Patent Classification (IPC) or to both national classification and IPC																				
<b>B. FIELDS SEARCHED</b> Minimum documentation searched (classification system followed by classification symbols) U.S. : 702/57; 370/286, 294, 401; 375/296, 346, 349; 364/141 Documentation searched other than minimum documentation to the extent that such documents are included in the fields searched Electronic data base consulted during the international search (name of data base and, where practicable, search terms used) APS																				
<b>C. DOCUMENTS CONSIDERED TO BE RELEVANT</b>																				
Category*	Citation of document, with indication, where appropriate, of the relevant passages	Relevant to claim No.																		
A	US 5,181,198 A (LECHLEIDER) 19 January, 1993 (19.01.93), Abstract, figs.1-7, cols.1-3.	1-40																		
A	US 5,504,896 (SCHELL et al.) 02 April, 1996 (02.04.96), Abstract, figs.1-10, cols.1-2.	1-40																		
<input type="checkbox"/> Further documents are listed in the continuation of Box C. <input type="checkbox"/> See patent family annex.																				
<table border="0"> <tr> <td>* Special categories of cited documents:</td> <td>*T*</td> <td>later document published after the international filing date or priority date and not in conflict with the application but cited to understand the principle or theory underlying the invention</td> </tr> <tr> <td>*A* document defining the general state of the art which is not considered to be of particular relevance</td> <td>*X*</td> <td>document of particular relevance; the claimed invention cannot be considered novel or cannot be considered to involve an inventive step when the document is taken alone</td> </tr> <tr> <td>*E* earlier document published on or after the international filing date</td> <td>*Y*</td> <td>document of particular relevance; the claimed invention cannot be considered to involve an inventive step when the document is combined with one or more other such documents, such combination being obvious to a person skilled in the art</td> </tr> <tr> <td>*L* document which may throw doubts on priority claim(s) or which is cited to establish the publication date of another citation or other special reason (as specified)</td> <td>*G*</td> <td>document member of the same patent family</td> </tr> <tr> <td>*O* document referring to an oral disclosure, use, exhibition or other means</td> <td></td> <td></td> </tr> <tr> <td>*P* document published prior to the international filing date but later than the priority date claimed</td> <td></td> <td></td> </tr> </table>			* Special categories of cited documents:	*T*	later document published after the international filing date or priority date and not in conflict with the application but cited to understand the principle or theory underlying the invention	*A* document defining the general state of the art which is not considered to be of particular relevance	*X*	document of particular relevance; the claimed invention cannot be considered novel or cannot be considered to involve an inventive step when the document is taken alone	*E* earlier document published on or after the international filing date	*Y*	document of particular relevance; the claimed invention cannot be considered to involve an inventive step when the document is combined with one or more other such documents, such combination being obvious to a person skilled in the art	*L* document which may throw doubts on priority claim(s) or which is cited to establish the publication date of another citation or other special reason (as specified)	*G*	document member of the same patent family	*O* document referring to an oral disclosure, use, exhibition or other means			*P* document published prior to the international filing date but later than the priority date claimed		
* Special categories of cited documents:	*T*	later document published after the international filing date or priority date and not in conflict with the application but cited to understand the principle or theory underlying the invention																		
*A* document defining the general state of the art which is not considered to be of particular relevance	*X*	document of particular relevance; the claimed invention cannot be considered novel or cannot be considered to involve an inventive step when the document is taken alone																		
*E* earlier document published on or after the international filing date	*Y*	document of particular relevance; the claimed invention cannot be considered to involve an inventive step when the document is combined with one or more other such documents, such combination being obvious to a person skilled in the art																		
*L* document which may throw doubts on priority claim(s) or which is cited to establish the publication date of another citation or other special reason (as specified)	*G*	document member of the same patent family																		
*O* document referring to an oral disclosure, use, exhibition or other means																				
*P* document published prior to the international filing date but later than the priority date claimed																				
Date of the actual completion of the international search 05 JULY 1999		Date of mailing of the international search report 27 JUL 1999																		
Name and mailing address of the ISA/US Commissioner of Patents and Trademarks Box PCT Washington, D.C. 20231 Facsimile No. (703) 305-3230		Authorized officer HIEN VO  Telephone No. (703) 308-5253																		



## INTERNATIONAL APPLICATION PUBLISHED UNDER THE PATENT COOPERATION TREATY (PCT)

<p>(51) International Patent Classification <sup>6</sup> : H04B 1/38, H04L 5/16, 27/10, 27/18</p>	<p>A1</p>	<p>(11) International Publication Number: <b>WO 99/67890</b></p> <p>(43) International Publication Date: 29 December 1999 (29.12.99)</p>
<p>(21) International Application Number: PCT/US99/13817</p> <p>(22) International Filing Date: 18 June 1999 (18.06.99)</p> <p>(30) Priority Data: 60/090,333                      23 June 1998 (23.06.98)                      US</p> <p>(71) Applicant (for all designated States except US): PC TEL, INC. [US/US]; 70 Rio Robles, San Jose, CA 95134 (US).</p> <p>(72) Inventors; and</p> <p>(75) Inventors/Applicants (for US only): GOLDSTEIN, Yuri [US/US]; 924 Bullet Hill Road, Southbury, CT 06488 (US). OKUNEV, Yuri [US/US]; 1023/B Heritage Village, Southbury, CT 06488 (US).</p> <p>(74) Agent: GORDON, David, P.; 65 Woods End Road, Stamford, CT 06905 (US).</p>	<p>(81) Designated States: AU, CA, CN, JP, KR, US, European patent (AT, BE, CH, CY, DE, DK, ES, FI, FR, GB, GR, IE, IT, LU, MC, NL, PT, SE).</p> <p><b>Published</b> <i>With international search report. Before the expiration of the time limit for amending the claims and to be republished in the event of the receipt of amendments.</i></p>	
<p>(54) Title: SPREAD SPECTRUM HANDSHAKE FOR DIGITAL SUBSCRIBER LINE TELECOMMUNICATIONS SYSTEMS</p> <p>(57) Abstract</p> <p>Handshake information for xDSL services is transmitted utilizing a spread spectrum modulated system where a plurality (n) of carrier tones (n &gt; 2) are summed and utilized as a spread spectrum carrier (SSC), and data is modulated onto the carrier (at all utilized frequencies). Preferably, phase shift keying (PSK) modulation or a variation thereof is used as the encoding/modulation technique.</p>		



**FOR THE PURPOSES OF INFORMATION ONLY**

Codes used to identify States party to the PCT on the front pages of pamphlets publishing international applications under the PCT.

AL	Albania	ES	Spain	LS	Lesotho	SI	Slovenia
AM	Armenia	FI	Finland	LT	Lithuania	SK	Slovakia
AT	Austria	FR	France	LU	Luxembourg	SN	Senegal
AU	Australia	GA	Gabon	LV	Latvia	SZ	Swaziland
AZ	Azerbaijan	GB	United Kingdom	MC	Monaco	TD	Chad
BA	Bosnia and Herzegovina	GE	Georgia	MD	Republic of Moldova	TG	Togo
BB	Barbados	GH	Ghana	MG	Madagascar	TJ	Tajikistan
BE	Belgium	GN	Guinea	MK	The former Yugoslav Republic of Macedonia	TM	Turkmenistan
BF	Burkina Faso	GR	Greece	ML	Mali	TR	Turkey
BG	Bulgaria	HU	Hungary	MN	Mongolia	TT	Trinidad and Tobago
BJ	Benin	IE	Ireland	MR	Mauritania	UA	Ukraine
BR	Brazil	IL	Israel	MW	Malawi	UG	Uganda
BY	Belarus	IS	Iceland	MX	Mexico	US	United States of America
CA	Canada	IT	Italy	NE	Niger	UZ	Uzbekistan
CF	Central African Republic	JP	Japan	NL	Netherlands	VN	Viet Nam
CG	Congo	KE	Kenya	NO	Norway	YU	Yugoslavia
CH	Switzerland	KG	Kyrgyzstan	NZ	New Zealand	ZW	Zimbabwe
CI	Côte d'Ivoire	KP	Democratic People's Republic of Korea	PL	Poland		
CM	Cameroon	KR	Republic of Korea	PT	Portugal		
CN	China	KZ	Kazakstan	RO	Romania		
CU	Cuba	LC	Saint Lucia	RU	Russian Federation		
CZ	Czech Republic	LI	Liechtenstein	SD	Sudan		
DE	Germany	LK	Sri Lanka	SE	Sweden		
DK	Denmark	LR	Liberia	SG	Singapore		
EE	Estonia						

SPREAD SPECTRUM HANDSHAKE FOR DIGITAL SUBSCRIBER LINE  
TELECOMMUNICATIONS SYSTEMS

Priority is claimed from provisional application Serial No. 60/090,333 filed June 23, 1998 which is hereby incorporated by reference in its entirety herein.

BACKGROUND OF THE INVENTION

1. Field of the Invention

The present invention relates broadly to telecommunications systems and methods. More particularly, the present invention relates to a handshake for an xDSL (Digital Subscriber Line type) modem.

2. State of the Art

• Digital subscriber line (DSL) systems are a new and fast-growing data transmission service which provide significantly higher data rates than conventional V.34 and V.90 type modems. The abbreviation "xDSL" is an integrated designation for different DSL services including ADSL (asymmetric DSL), SDSL (symmetric DSL), RADSL (rate-adaptive DSL), HDSL (high speed DSL), and VDSL (very high speed DSL), UDSL (universal DSL), and their modifications such as ADSL-LITE (also known as G.lite). The xDSL services typically provide data rates of several Mbits/s downstream and several hundred Kbits/s upstream, although SDSL provides the same upstream and downstream rates. All types of DSL are based on discrete multitone (DMT) technology although they have different parameters. See, J. Makris, "DSL Services", Data Communications, April 1998, and ANSI T1.413 -1995 "Network and Customer Installation Interfaces - Asymmetrical Digital Subscriber Line (ADSL) Metallic Interface".

According to the ITU-T telecommunications standards for the xDSL services, at modem start-up a handshake procedure (called G.hs) is utilized. The requirements for G.hs are set forth in several documents such as "Proposal for G.hs Modulation

Technique and Message Protocol", ITU-T Telecommunication Standardization Sector, C1-068 Chicago, USA 6-9 April 1998, and "Handshake procedures for Digital Subscriber Line (DSL) transceivers", ITU-T Draft G.994.1 (February 3, 1999) which are both hereby incorporated by reference herein in their entireties. The main requirements of the handshake are: transmission of several tens of bytes during the handshake; signal compatibility with all types of DSL receivers; and interworking with the plain old telephone service (POTS), the integrated services digital network (ISDN), and time compression multiplexing ISDN (TCM-ISDN). Meeting these main requirements is not a trivial task because of considerable noise and cross-talk impairments, and lack of knowledge regarding the frequency characteristics of the channel, all of which is described in various papers such as: Matsushita Electric Industrial Co. Ltd, "Proposed Working Text for G.hs Based on V.8bis", ITU-Telecommunication Standardization Sector, NF-044, Nice, France, 11-14 May 1998; Matsushita Electric Industrial Co. Ltd., "Spectrum Considerations for G.hs", ITU-Telecommunications Standardization Sector, NF-045, Nice, France 11-14 May 1998; Matsushita Electric Industrial Co., Ltd., "Crosstalk Model Proposed Working Text for G.hs Test" ITU-Telecommunications Standardization Sector, NF-046, Nice, France 11-14 May 1998; NEC, "Desired Spectrum Range for G.hs under TCM-ISDN", ITU-Telecommunications Standardization Sector, NF-066, Nice, France 11-14 May 1998; and 3Com, "Proposed Spectrum and Tone Selection for G.hs", ITU-Telecommunications Standardization Sector, NF-068, Nice, France 11-14 May 1998.

More particularly, signal attenuation across lines carrying xDSL signals is a non-monotonic function of frequency, and may have several deep notches, while noise power spectral density (PSD) is also not a flat function of frequency. As a result, the signal to noise ratio (SNR) is a complex multiextremes function of frequency. Moreover, the SNR is subject to random and cyclic variations in time. For example, in the TCM-ISDN environment which includes the so-called "ping-pong mode" of up- and down-transmissions, far-end cross-talk (FEXT) and near-end

cross-talk (NEXT) interleave at a frequency of 400 Hz. Since FEXT and NEXT processes have significantly different power spectral densities, significant NEXT noise is introduced every other 1.25 milliseconds.

As set forth above, several authors have made proposals regarding G.h.s techniques. The core of these proposals has been two-tone transmission with different bit rates depending upon the noise environment. Frequency diversity is provided by bits duplication on nominal and backup carrier tones. Time diversity is provided by increasing the symbol interval (i.e., decreasing the symbol rate). These proposals have several disadvantages. First, both the nominal and backup tones may be located in notches or other frequency domain areas having a low SNR, thus rendering the handshake ineffective. Second, increasing the symbol interval may not be sufficient to account for bursty noise. For example, in the TCM-ISDN environment, the signal to noise ratio may be below an acceptable level every other 1.25 ms interval. Even if the initial symbol interval of .232 ms were to be increased by a factor of four to .928 ms as suggested by one of the authors in the art, the entire interval could be located within the 1.25 ms high noise window. In fact, even increasing the symbol interval by a factor of 8 would still only provide a final symbol interval of 1.885 ms which could be 67% covered by the low SNR area.

#### SUMMARY OF THE INVENTION

It is therefore an object of the invention to provide a handshake for an xDSL modem which meets proposed xDSL standards requirements.

It is another object of the invention to provide a handshake for an xDSL modem which has excellent frequency diversity and time diversity and provides excellent reliability.

It is a further object of the invention to provide an xDSL modem handshake which utilizes multitone signaling.

It is an additional object of the invention to provide an xDSL modem handshake which will interwork with existing telecommunications services.

Another object of the invention is to provide modems and methods for implementing the above-listed objects.

In accord with the objects of the invention, handshake information for xDSL services are transmitted utilizing a spread spectrum modulated system where a plurality (n) of carrier tones ( $n > 2$ ) are summed and utilized as a spread spectrum carrier (SSC), and data is modulated onto the carrier (at all utilized frequencies). Preferably, phase shift keying (PSK) modulation (or a variation thereof such as BPSK - binary PSK, or DBPSK - differential binary PSK) is used as the modulating technique. When the spread spectrum carrier is modulated by handshake bits according to BPSK, the SSC is transmitted with sign "+" if the handshake bit is a +1 and with sign "-" if the handshake bit is a "-1". When using DPSK, the same modulation procedure is used for differentially encoded handshake bits.

According to one preferred aspect of the invention, the handshake symbol rate (SR) is set equal to  $.8A$  symbols/msec, where A is a positive integer. In order to improve reliability, symbols are preferably repeated at least four times. According to another preferred aspect of the invention, a preamble can be provided for timing recovery purposes. Further aspects of the invention include different receiver systems, including a quasioherent receiver, an autocorrelation receiver, and a presently preferred incoherent receiver which utilizes coherent accumulation of FFT components for a DBPSK spread spectrum handshake signal.

Additional objects and advantages of the invention will become apparent to those skilled in the art upon reference to the detailed description taken in conjunction with the provided figures.

## BRIEF DESCRIPTION OF THE DRAWINGS

Fig. 1 is a block diagram of the preferred transmitter of the invention.

Fig. 2 is a diagram showing the signal structure of the preferred handshake signal of the invention.

Fig. 3a is a block diagram of an autocorrelation receiver of DBPSK signals according to the invention;

Fig. 3b is a block diagram of a quasioherent receiver of DBPSK signals according to the invention; and

Fig. 3c is a block diagram of an incoherent receiver which utilizes coherent accumulation of FFT components for a DBPSK spread spectrum handshake signal according to the invention.

## DETAILED DESCRIPTION OF THE PREFERRED EMBODIMENT

According to the invention, handshake information for xDSL services is transmitted by modulating the handshake information on a spread spectrum carrier (SSC), where the SSC is a sum of tones conventionally used by xDSL for the data transmission mode. As seen in Fig. 1, the transmitter 10 includes a phase initialization (PI) unit 15, an inverse fast Fourier transformation (IFFT) unit 20, a spread spectrum carrier (SSC) memory 25, a modulator 30, a differential encoder 35 and a block frame unit 40. In essence, the phase initialization unit 15 generates complex numbers indicating a desirable amplitude and initial phase distribution for a plurality of multitone signals. Preferably, the amplitude distribution is chosen to be flat (uniform). According to the preferred embodiment, the initial phases of different tones are generated randomly or selected specifically in order to minimize the crest-factor of the generated tones. Regardless, where DMT-style implementation is utilized, the IFFT transforms a set of complex numbers into a

set of time-domain samples which are stored in memory 25. If, for example, all or substantially all two hundred fifty-six DMT tones (such as might be utilized in ITU-T Standard G.992.2) are generated by the PI unit 15, a five hundred twelve sample set may be stored in the memory 25. Additional repetitive samples may also be stored in the memory, if desired as a prefix which can be used by the receiver to reduce distortion. If desired, the samples may be generated in other manners (e.g., without the PI and IFFT, or in another apparatus) and loaded and stored in the transmitter memory for use as described below.

While all two hundred fifty-six DMT tones may be included in the spread spectrum carrier, it should be appreciated by those skilled in the art that according to the invention, different numbers of tones (and different tones) can be used in different circumstances, provided a spread spectrum carrier is utilized. Thus, for purposes of this application, a carrier may be considered a spread spectrum carrier if three or more distinct tones are modulated together. Thus, the SSC for a down-stream connection may contain a full or partial set of down-stream tones, while the SSC for an up-stream connection could contain a full or partial set of up-stream tones. For example, a G.Lite ADSL up-stream SSC might utilize allowed tones from the set six through thirty-two (25.875 kHz... 138 kHz), while the downstream SSC might utilize allowed tones from the set thirty-three through one hundred twenty-eight (142.3125 kHz ... 552 kHz). The SSC may contain only even or odd tones to reduce the processing at the receiver.

Handshake information (as described below with reference to Fig. 2) which is to be modulated onto the spread spectrum carrier is provided to the differential encoder 35 and differentially encoded bits are written to the block frame unit 40. According to the preferred embodiment of the invention, the handshake information is provided to the differential encoder at a speed of .8 kbps, and differentially encoded 4-bit subblocks are written into registers of the block frame unit 40. Preferably, each 4-bit subblock is read four times such that

each block frame is provided to the modulator 30 with a speed of 3.2 kbps.

When no differential encoder is utilized, the modulation technique is preferably is a binary phase shift keying (BPSK). When a differential encoder is utilized, the modulation technique is preferably a differential BPSK. Regardless, the modulator 30 uses the output of the block framer unit 40 to select whether the samples stored in the memory 25 are to be transmitted as is, or inverted (i.e., multiplied by -1 or 180 degrees out of phase). The samples stored in the memory 25 are sequentially read out of the memory so that all samples are modulated (i.e., transmitted as is or inverted) at the proposed symbol rate discussed below. When BPSK is utilized, the SSC samples are transmitted with sign "+" if the handshake bit is a "+1", and transmitted with sign "-" if the handshake bit is "-1" (or vice versa). When using DBPSK, the same modulation procedure is used for differentially encoded handshake bits.

It will be appreciated by those skilled in the art that while BPSK or DBPSK modulation is preferred, other modulation techniques such as QPSK (quadrature PSK), DQPSK (differential QPSK), frequency modulation, amplitude modulation, and quadrature amplitude modulation could be utilized.

Details of the handshake which modulates the SSC is seen in Fig. 2. According to the preferred embodiment of the invention, the handshake includes a preamble and a G.hs message. The preamble comprises N subblocks of a distinct four bit sequence "1,1,1,-1" followed by four subblocks of a four bit divider sequence "-1,-1,-1,-1", followed by eight subblocks of a pseudorandom sequence (as specified). Each subblock is preferably generated at a 1.25 millisecond rate (i.e., each subblock has a duration of 1.25 ms), with bits being generated at a .3125 millisecond rate. After the preamble, the G.hs message is provided and preferably includes N blocks which are generated at a 5 millisecond rate. Each block preferably includes four subblocks of four information bits (symbols) each (b1, b2, b3, b4), with the four information bits being repeated



four times (i.e., each subblock within the block contains the same material). Each symbol carries one information bit. So each block of duration 5 milliseconds, carries four information bits with redundancy  $3/4$ . As indicated in Fig. 2, each bit of the preamble and G.hs message is preferably modulated onto a spread spectrum carrier. As discussed in more detail below, the preamble is preferably provided to permit the receiver to detect G.hs transmission, to recover the spread spectrum carrier for coherent processing, and for symbol and block synchronization (timing recovery). While the preamble is preferably modulated, an unmodulated preamble (all +1s) can be utilized.

According to the preferred embodiment of the invention, a symbol rate (SR) is set equal to  $.8$  symbols/millisecond, where  $A = 1, 2, 3, \dots$ . With the symbol rate set in this manner, an integer number of symbols will be placed within the 1.25 millisecond burst duration in the TCM-ISDN cross talk environment. Thus, when  $A=4$  (bit rate = 3200 bps), half a byte (four bits) will be transmitted within the 1.25 ms burst. When  $A=8$  (bit rate = 6400 bps), one byte will be transmitted within the 1.25 ms burst. By transmitting each symbol of the G.hs message at least four times, at least two symbol time-separated blocks will occur within the 1.25 ms high SNR FEXT areas in a TCM-ISDN cross-talk environment.

Taking into account the 400 Hz periodicity of the NEXT and FEXT cross-talk in TCM-ISDN systems, a noiseless time window may be found by calculating the correlation between N-symbol blocks delayed by 2.5 ms relative to each other. If the delayed blocks coincide with each other (i.e., they have not been corrupted by noise), the time window has a "high enough" SNR (i.e., it is "noiseless" for the purpose of the handshake) and can be used for receiving the handshake message. The structure of the preamble is particularly arranged to permit this determination.

Because the noiseless time window has a random time position relative to the transmission of the preamble and handshake message, received N-symbol blocks may be cyclically

shifted. In other words, the block frame may not correspond to the noiseless time window frame. It is therefore preferred that this shift be estimated and eliminated. According to the preferred embodiment of the invention, the cyclic shift may be estimated and eliminated by transmitting an N-symbol reference block. Thus, the preamble is provided with a series of reference blocks having the form "1,1,1,-1". It should be appreciated that any shift of the reference block will be distinct (-1,1,1,1; 1,-1,1,1; 1,1,-1,1) and detectable, and may therefore be detected and eliminated at the receiver. This pattern therefore allows for symbol synchronization and subblock synchronization.

Turning now to Figs. 3a-3c, three different receivers are shown for receiving and demodulating the handshake signal of the invention. An autocorrelation receiver 100a for DBPSK spread spectrum handshake signals is seen in Fig. 3a. The autocorrelation receiver 100a includes an autocorrelation demodulator 102a, a timing signal extractor 103a, and preferably further includes a noiseless time window (TW) determination unit 104a and a transmitted bit selection (BS) unit 106a. The autocorrelation demodulator 102a includes a delay line (DL) 110a, a multiplier 112a, a low pass filter (LPF) 114a, and a binary slicer (Sgn) 116a. Incoming SSC modulated signals are provided to the delay line 110a and the multiplier 112a. The delay  $\Delta t$  of the delay line is preferably set equal to  $1/.8A$  ms (i.e., the handshake symbol duration). Thus, the multiplier 112a multiplies the incoming signal with the delayed signal. The output is forwarded to the low pass filter 114a which is preferably provided with a frequency bandwidth  $\Delta f$  approximately equal to  $A/1.25$  kHz. For example, when using block length  $A=4$ ,  $\Delta t = 0.3125$  ms, and  $\Delta f = 3.2$  kHz. The output of the low pass filter 114a reflects the modulation function in the transmitter, and the sign function of the low pass filter output, as generated by the binary slicer 116a which compares the output to a zero threshold, corresponds to the transmitted bits.

As will be appreciated by those skilled in the art, the

autocorrelation receiver 100a calculates (at the multiplier 112a) a scalar product ( $S_n(t) * S_{n-1}(t)$ ) between a given spread spectrum signal  $S_n(t)$  and a previous spread spectrum signal  $S_{n-1}(t)$ . The binary symbol  $I_n$  received with the n-th symbol interval is therefore determined according to  $I_n = \text{sgn}(S_n(t) * S_{n-1}(t))$ .

As seen in Fig. 3a, the binary slicer 116a requires timing information which is preferably extracted from the low pass filter output by bandpass filtering of a frequency component responding to the baud (symbol) frequency. Alternatively (and also as shown in Fig. 3a), the timing information can be extracted from the incoming signal by a variety of well-known methods; e.g., as taught in Jan W. M. Bergmans, Digital Baseband Transmission and Recording, Chapters 9 and 10, "Basics of Timing Recovery", and "A Catalog of Timing Recovery Schemes", Kluwer Academic Publishers, Boston (1996) pp. 451-587.

While the autocorrelation demodulator 102a in conjunction with the timing extractor 103a suffices as a G.h.s receiver in situations which do not require carrier recovery or other special synchronization, additional circuitry can be utilized if desired. Thus, if the channel noise has a steady power spectral density, robustness can be increased by accumulating signals at the output of the low pass filter, taking into account that every symbol may be repeated several times. In addition, if the PSD is known, the spread spectrum signal may be passed through a corresponding filter (not shown) at the input of the receiver in order to emphasize components of the spread spectrum signal having a higher SNR.

In addition, and according to the preferred embodiment of the invention, where a preamble is utilized, a noiseless time window determination unit 104a can be provided to compare the signal subblocks containing N symbols and delayed relative to each other by 2.5 ms. If the delayed N bit combination coincides within a certain time window, it indicates that this

window has a sufficiently high SNR and can be used for receiving handshake bits. Regardless, the window determination unit 104 finds the time window of interest and generates an output signal indicating the time position of the desired window which is provided to the bit selection unit 106a. The demodulated bits provided at the output of the slicer during the noiseless window are also provided to the bit selection unit 106a, which determines from the bits and the window information the cyclic shift in effect. Thus, during receipt of the G.hs message, the bit selection unit 106a selects the correct portion of the received bits and eliminates the cyclic shift in the received information blocks. The bit selection unit 106a produces for output N bits every 5 milliseconds.

Turning to Fig. 3b, a quasioherent receiver 100b for DBPSK spread spectrum handshake signals is shown. The quasioherent receiver 100b includes an autocorrelation demodulator 102b, a timing signal extractor 103b, and preferably further includes a noiseless time window determination unit 104b and a transmitted bit selection unit 106b. The quasioherent demodulator 102b includes a spread spectrum recovery (SSCR) unit 111b, a multiplier 112b, a low pass filter 114b, a binary slicer 116b, a delay line 118b, and a sign multiplier 120b. Incoming SSC modulated signals are provided to the spread spectrum carrier recovery unit 111b and the multiplier 112b. The spread spectrum carrier recovery unit 111b accumulates SSC samples during the preamble and extracts a spread spectrum reference signal  $R(t)$  therefrom. The multiplier 112b multiplies the incoming signal with the output of the SSC recovery unit. The output is forwarded to the low pass filter 114b which is preferably provided with a frequency bandwidth  $\Delta f$  approximately equal to  $N/1.25$  kHz. The output of the low pass filter 114b is fed to slicer 116b which compares the output to a threshold (typically zero). The output of slicer 116b is a binary signal which is fed to the delay line 118b and to the sign multiplier 120b. The sign of the output of the sign multiplier 120b corresponds to the transmitted bits.

As will be appreciated by those skilled in the art, in the quasicohherent receiver 100b, the average unmodulated SSC, preferably extracted from the preamble by the SSC recovery unit 111b, is used as a spread spectrum reference signal  $R(t)$  for the coherent demodulation. Thus, the recovered binary symbol  $I_n = J_n * J_{n-1}$ , where  $J_n = \text{sgn}(S_n(t) * R(t))$ , and  $J_{n-1} = \text{sgn}(S_{n-1}(t) * R(t))$ . The quasicohherent receiver 100b provides excellent results, but is substantially more complicated to implement than the autocorrelation receiver 100a because of the SSC recovery unit 111b.

The functioning of the timing signal extractor 103b, and the time window determination unit 104b and bit selection unit 106b of the quasicohherent receiver 100b are substantially as described above with respect to corresponding elements of Fig. 3a.

Turning to Fig. 3c, an incoherent receiver 100c for DBPSK spread spectrum handshake signals is shown. As seen in Fig. 3c, the incoherent receiver includes a fast Fourier transform block 130, a quadrature component accumulation unit 135, a multichannel incoherent demodulator 140, a DMT accumulation unit 145, and a binary slicer 150. The FFT block 130 receives the time domain handshake signal and converts the signal into a frequency domain signal. The output of the FFT block are signals  $F_{cnkm}$  and  $F_{snkm}$  which are respectively, the real and complex parts for the  $k$ -th DMT tone at the  $m$ -th DMT symbol interval of the  $n$ -th handshake symbol. The quadrature component accumulation (QCA) unit 145 separately sums the real parts together and the imaginary parts together according to  $F_{cnk} = \sum_m F_{cnkm}$  and  $F_{snk} = \sum_m F_{snkm}$ . The outputs of the quadrature

component accumulation unit 145 are then demodulated by the incoherent demodulator 140 according to

$F_{nk} = F_{cnk} * F_{c(n-1)k} + F_{snk} * F_{s(n-1)k}$ . The outputs of the incoherent demodulator 140 are then summed over all tones  $k$  by the DMT accumulator (DMTA) 145 according to  $F_n = \sum_k F_{nk}$ . Finally, the

output of the DMT accumulator 145 is provided to the binary slicer 150 in order to compare the output  $F_n$  to a zero threshold. The decoded binary symbol  $I_n = \text{sgn}(F_n)$ .

It should be appreciated by those skilled in the art that the incoherent receiver 100c is relatively simple to implement because it is based on the use of a FFT which is already available in DMT-based systems. In addition, no frequency equalization (carrier phase recovery) is required, and the performance of the incoherent receiver 100c is nearly as good as the quasicohherent receiver 100b of Fig. 3b.

There have been described and illustrated herein methods and apparatus for implementing a spread spectrum handshake for a digital subscriber line telecommunications system. While particular embodiments of the invention have been described, it is not intended that the invention be limited thereto, as it is intended that the invention be as broad in scope as the art will allow and that the specification be read likewise. Thus, while a particular transmitter and particular receivers have been disclosed, it will be appreciated that other transmitters and receivers could be utilized, provided that the transmitter modulate a handshake signal onto a spread spectrum carrier. Thus the implementation of the transmitters and receivers will partially depend upon the encoding technique utilized (e.g., DPSK, QPSK, etc.), the results desired, and limitations or requirements of standards which might be applicable. Implementation of functions may also be accomplished in several manners. Thus, while slicers have been described for purposes of generating decoded binary signals, other apparatus well-known in the art could be utilized. Also, while a handshake sequence including a preamble and a handshake message have been described, it will be appreciated that different preambles and different handshake messages could be provided, and/or that a handshake sequence could be provided with no preamble. It will therefore be appreciated by those skilled in the art that yet other modifications could be made to the provided invention without deviating from its spirit and scope as so claimed.

We claim:

1. A digital subscriber line (DSL) type modem, comprising:
  - a transmitter having
    - a handshake generator which generates handshake signals,
    - a spread spectrum carrier generator which generates a spread spectrum carrier including at least three tones associated with DSL type modems, and
    - a modulator coupled to said handshake generator and to said spread spectrum carrier generator, said modulator modulating indications of said handshake signals onto indications of said spread spectrum carrier simultaneously.
2. A modem according to claim 1, wherein:
  - said modulator modulates said indications of said spread spectrum carrier according to one of a phase shift keying (PSK) technique, frequency modulation, amplitude modulation, and quadrature amplitude modulation.
3. A modem according to claim 2, wherein:
  - said PSK technique comprises one of binary PSK, differential binary PSK, quadrature PSK, and differential quadrature PSK.
4. A modem according to claim 1, wherein:
  - said modulator modulates said indications of said spread spectrum carrier according to differential binary phase shift keying.
5. A modem according to claim 4, wherein:
  - said spread spectrum carrier generator comprises memory which stores said indications of all said tones.
6. A modem according to claim 5, wherein:
  - said indications comprise inverse fast Fourier transform (IFFT) samples of said at least three tones.

7. A modem according to claim 6, wherein:  
said indications comprise IFFT samples of substantially all two hundred fifty-six DMT tones associates with DSL type modems.
8. A modem according to claim 1, wherein:  
said spread spectrum carrier generator comprises memory which stores said indications of all said tones.
9. A modem according to claim 8, wherein:  
said indications of all said tones comprise inverse fast Fourier transform (IFFT) samples of said at least three tones.
10. A modem according to claim 9, wherein:  
said indications of all said tones comprise IFFT samples of substantially all two hundred fifty-six DMT tones associates with DSL type modems.
11. A modem according to claim 1, wherein:  
said handshake generator comprises a differential encoder coupled to a block framer.
12. A modem according to claim 1, wherein:  
said handshake signals comprise a handshake message.
13. A modem according to claim 12, wherein:  
said handshake message includes a plurality of blocks, each block having a plurality of repeating subblocks.
14. A modem according to claim 13, wherein:  
said blocks have a 5 millisecond rate.
15. A modem according to claim 14, wherein:  
said subblocks have a 1.25 millisecond rate, and each subblock contains four bits.
16. A modem according to claim 12, wherein:  
said handshake signals further comprise a preamble.



17. A modem according to claim 16, wherein:  
said preamble comprises a plurality of repeating subblocks.
18. A modem according to claim 17, wherein:  
each said subblock has a 1.25 millisecond rate and includes four predetermined bits, said four predetermined bits selected to permit a shift in phase of said four predetermined bits to be detected.
19. A modem according to claim 17, wherein:  
said preamble further includes at least one subblock having a divider sequence, and a plurality of subblocks representing a pseudorandom sequence.
20. A modem according to claim 1, further comprising:  
a receiver having a demodulator.
21. A modem according to claim 20, wherein:  
said receiver is chosen from a group consisting of an autocorrelation receiver, a quasicohherent receiver, and an incoherent receiver.
22. A modem according to claim 21, wherein:  
said receiver is an autocorrelation receiver including a delay line which receives and delays a received handshake signal, a multiplier which multiplies said received handshake signal with an output of said delay line, a low pass filter which filters an output of the multiplier, and means for obtaining binary symbol indication from an output of said low pass filter.

23. A modem according to claim 21, wherein:

said receiver is a quasicohherent receiver including a spread spectrum carrier recovery unit generates a reference spread spectrum signal from the received signal, a multiplier which multiplies a received signal with said reference signal, a low pass filter which filters an output of the multiplier, and means for obtaining a binary symbol indication from an output of said low pass filter.

24. A modem according to claim 23, wherein:

said means for obtaining a binary symbol indication comprises a slicer coupled to an output of said low pass filter, a delay line which receives and delays outputs of said slicer, and a second multiplier which receives an output of said slicer and an output of said delay line and generates a binary symbol indication therefrom.

25. A modem according to claim 21, wherein:

said receiver is an incoherent receiver including a fast Fourier transformer (FFT) which receives an incoming time domain handshake signal and generates real and imaginary frequency domain signals therefrom, a quadrature component accumulation (QCA) unit coupled to said FFT which separately sums said real frequency domain signals together and said imaginary frequency domain signals together, an incoherent demodulator coupled to said QCA unit which combines said summed real and imaginary frequency domain signals, a discrete multitone accumulator (DMTA) coupled to said QCA unit which sums outputs of said QCA unit over said at least three tones, and means for generating a decoded binary symbol from an output of said DMTA.

26. A modem according to claim 20, wherein:

said handshake signals comprise a handshake message and a preamble, said preamble comprises a plurality of repeating subblocks, wherein said receiver includes means for utilizing said repeating subblocks to find a high-signal-to-noise time window.

27. A modem according to claim 26, wherein  
said means for utilizing said repeating subblocks includes  
means for correlation of said repeating subblocks delayed  
relative to each other by a predetermined time interval.
28. A method of transmitting digital subscriber line (DSL) type  
modem handshake information, comprising:  
generating handshake signals; and  
modulating indications of said handshake signals onto a spread  
spectrum carrier, said spread spectrum carrier including at  
least three tones associated with DSL type modems, wherein said  
modulating comprises modulating said indications of said  
handshake signals onto indications of said at least three tones  
simultaneously.
29. A method according to claim 28, wherein:  
said handshake signal indications are modulated onto said  
spread spectrum carrier according to one of a phase shift keying  
(PSK) technique, frequency modulation, amplitude modulation, and  
quadrature amplitude modulation.
30. A method according to claim 29, wherein:  
said PSK technique comprises one of binary PSK,  
differential binary PSK, quadrature PSK, and differential  
quadrature PSK.
31. A method according to claim 28, wherein:  
said handshake signal indications are modulated onto said  
spread spectrum carrier according to differential binary phase  
shift keying.
32. A method according to claim 28, further comprising:  
generating said indications by taking an inverse fast  
Fourier transform (IFFT) of said at least three tones; and  
storing said indications in memory, wherein said modulating  
comprises reading said indications from memory in order to  
modulate said indications of said handshake signals onto said  
indications stored in memory.

33. A method according to claim 28, wherein:  
said handshake signals comprise a handshake message, said handshake message including a plurality of blocks, each block having a plurality of repeating subblocks.
34. A method according to claim 33, wherein:  
said blocks have a 5 millisecond rate, said subblocks have a 1.25 millisecond rate, and each subblock contains four bits.
35. A method according to claim 33, wherein:  
said handshake signals further comprise a preamble.
36. A method according to claim 33, wherein:  
said preamble comprises a plurality of repeating subblocks, each said subblock has a 1.25 millisecond rate and includes four predetermined bits, said four predetermined bits selected to permit a shift in phase of said four predetermined bits to be detected.
37. A method according to claim 36, wherein:  
said preamble further includes at least one subblock having a divider sequence, and a plurality of subblocks representing a pseudorandom sequence.

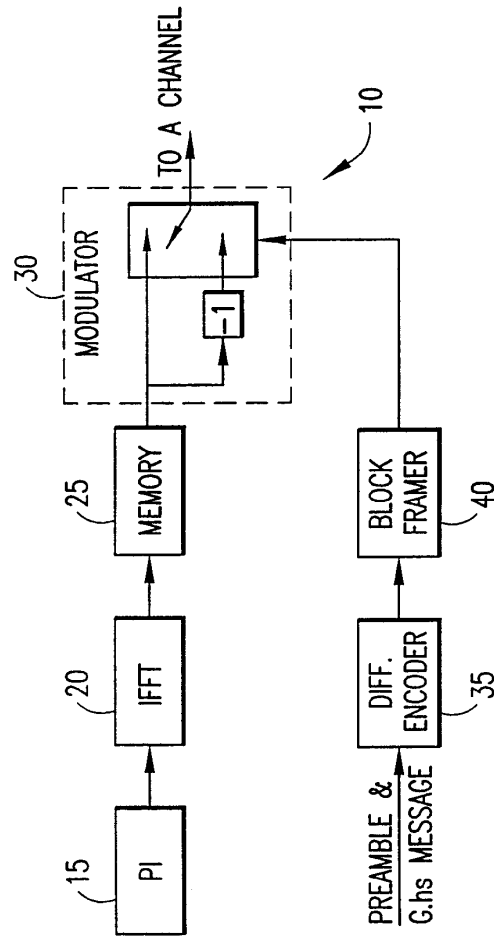

FIG.1

SUBSTITUTE SHEET (RULE 26)



3/3

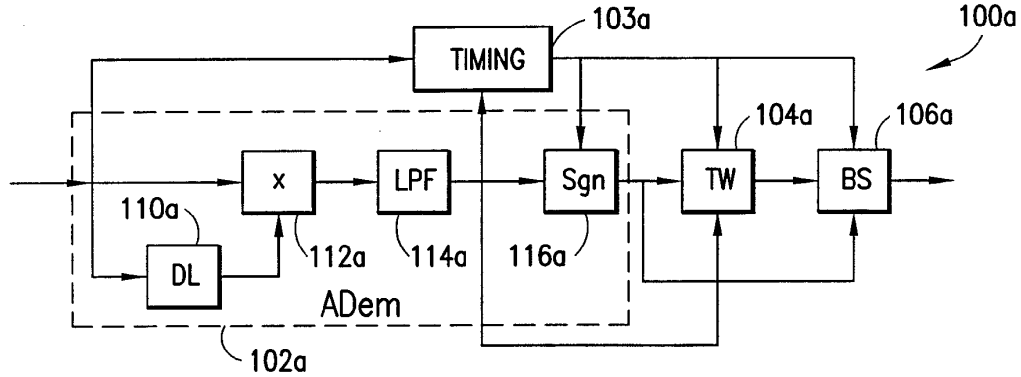

FIG.3a

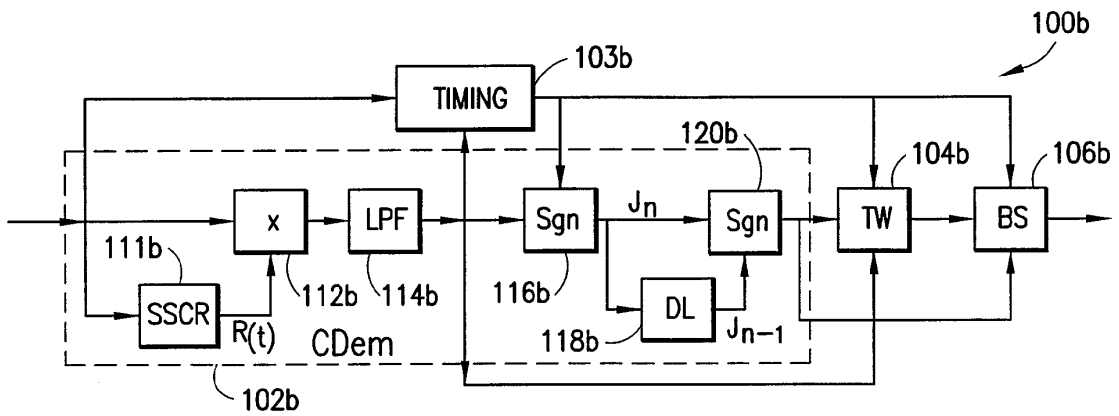

FIG.3b

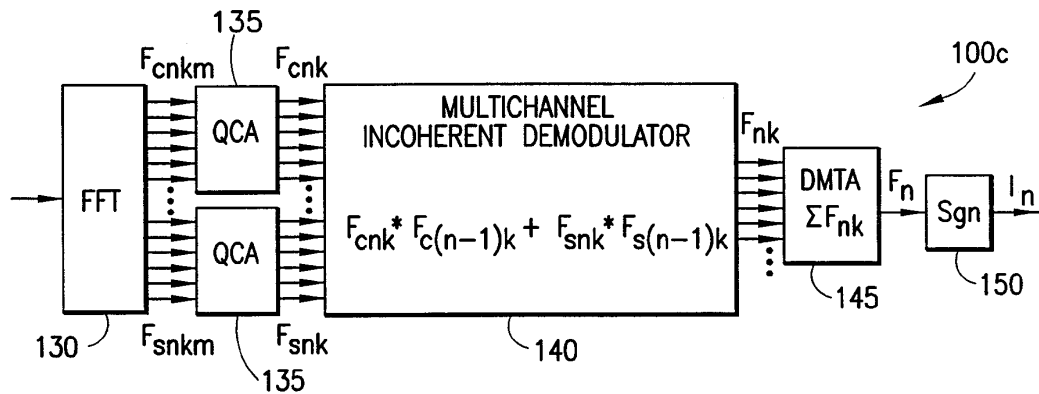

FIG.3c

SUBSTITUTE SHEET (RULE 26)

INTERNATIONAL SEARCH REPORT

International application No.  
PCT/US99/13817

<b>A. CLASSIFICATION OF SUBJECT MATTER</b> IPC(6) :H04B 1/38; H04L 5/16, 27/10, 27/18 US CL :375/222, 223, 200, 208, 209, 210 According to International Patent Classification (IPC) or to both national classification and IPC		
<b>B. FIELDS SEARCHED</b> Minimum documentation searched (classification system followed by classification symbols) U.S. : 375/222, 223, 200, 208, 209, 210 Documentation searched other than minimum documentation to the extent that such documents are included in the fields searched Electronic data base consulted during the international search (name of data base and, where practicable, search terms used) APS		
<b>C. DOCUMENTS CONSIDERED TO BE RELEVANT</b>		
Category*	Citation of document, with indication, where appropriate, of the relevant passages	Relevant to claim No.
Y	US 5,751,701 A (LANGBERG et al.) 12 May 1998, Figs. 3,4,7, and 10, cols. 3-7.	1-10, 12-21, 26-37
Y,P	US 5,909,463 A (JOHNSON et al.) 01 June 1999, Figs. 1-4, col. 1, lines 20-60 and col. 16, lines 15-64.	1-10, 12-21, 26-37
Y	US 5,644,573 A (BINGHAM et al.) 01 July 1997, col. 8, lines 50-60.	3-7, 9, 10, 31 and 32
A,P	US 5,883,907 A (HOEKSTRA) 16 March 1999, Fig. 2 and col. 3, lines 27-35.	1-37
<input type="checkbox"/> Further documents are listed in the continuation of Box C. <input type="checkbox"/> See patent family annex.		
* Special categories of cited documents: *A* document defining the general state of the art which is not considered to be of particular relevance *E* earlier document published on or after the international filing date *L* document which may throw doubts on priority claim(s) or which is cited to establish the publication date of another citation or other special reason (as specified) *O* document referring to an oral disclosure, use, exhibition or other means *P* document published prior to the international filing date but later than the priority date claimed *T* later document published after the international filing date or priority date and not in conflict with the application but cited to understand the principle or theory underlying the invention *X* document of particular relevance, the claimed invention cannot be considered novel or cannot be considered to involve an inventive step when the document is taken alone *Y* document of particular relevance; the claimed invention cannot be considered to involve an inventive step when the document is combined with one or more other such documents, such combination being obvious to a person skilled in the art *&* document member of the same patent family		
Date of the actual completion of the international search 23 AUGUST 1999		Date of mailing of the international search report 21 OCT 1999
Name and mailing address of the ISA/US Commissioner of Patents and Trademarks Box PCT Washington, D.C. 20231 Facsimile No. (703) 305-3230		Authorized officer MICHAEL W. MADDOX Telephone No. (703) 308-9557

Form PCT/ISA/210 (second sheet)(July 1992)\*



81573-8

# PATENT COOPERATION TREATY

From the  
INTERNATIONAL PRELIMINARY EXAMINING AUTHORITY

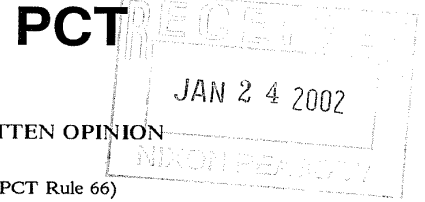

To:  
 Vick, Jason H.  
 Nixon Peabody LLP  
 8180 Greensboro Drive, Suite 800  
 McLean, Virginia 22102  
 ETATS-UNIS D'AMERIQUE

WRITTEN OPINION  
(PCT Rule 66)

Date of mailing (day/month/year)		18/01/2002
Applicant's or agent's file reference 031513.4		<b>REPLY DUE</b> within 1 / 00 months/days from the above date of mailing
International application No. PCT/US 01/ 00418	International filing date (day/month/year) 08/01/2001	Priority date (day/month/year) 07/01/2000
International Patent Classification (IPC) or both national classification and IPC H04L1/24		
Applicant AWARE, INC.		

1. This written opinion is the first drawn up by this International Preliminary Examining Authority.

2. This opinion contains indications relating to the following items:

- I  Basis of the opinion
- II  Priority
- III  Non-establishment of opinion with regard to novelty, inventive step and industrial applicability
- IV  Lack of unity of invention
- V  Reasoned statement under Rule 66.2(a)(ii) with regard to novelty, inventive step or industrial applicability; citations and explanations supporting such statement
- VI  Certain documents cited
- VII  Certain defects in the international application
- VIII  Certain observations on the international application

3. The applicant is hereby **invited to reply** to this opinion.

**When?** See the time limit indicated above. The applicant may, before the expiration of that time limit, request this Authority to grant an extension, see Rule 66.2(d).

**How?** By submitting a written reply, accompanied, where appropriate, by amendments, according to Rule 66.3. For the form and the language of the amendments, see Rules 66.8 and 66.9.

**Also** For an additional opportunity to submit amendments, see Rule 66.4. For the examiner's obligation to consider amendments and/or arguments, see Rule 66.4bis. For an informal communication with the examiner, see Rule 66.6.

**If no reply is filed**, the international preliminary examination report will be established on the basis of this opinion.

4. The final date by which the international preliminary examination report must be established according to Rule 69.2 is: 07/05/2002

Name and mailing address of the IPEA/  European Patent Office D-80298 Munich Tel. (+49-89) 2399-0, Tx: 523656 epmu d Fax: (+49-89) 2399-4465	Authorized officer
	Examiner
	Formalities officer (incl. extension of time limits) Tel. (+49-89) 2399 2828

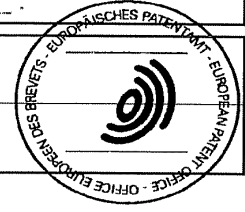

Form PCT/IPEA/408 (cover sheet) (July 1998) DOCKETED  
 1/24/02 By mm  
 Nixon Peabody, LLP

**I. Basis of the opinion**

1. The basis of this written opinion is the application as originally filed.

**III. Non-establishment of opinion with regard to novelty, inventive step and industrial applicability**

2. The question of whether the claimed invention appears to be novel, to involve an inventive step, or to be industrially applicable has not been and will not be the subject of the international preliminary examination (Article 34 (4) (a) (i) (ii) PCT; see also international search report) in respect of:

- 2.1 Applications having an unnecessary plurality of independent claims (generally not more than 1 independent claim in the same category is necessary; Article 6 PCT);

- 2.2 unsearched subject-matter (Article 17 (2) (a), Rule 66.1 (e) PCT), e.g.

- 2.2.1 claimed subject-matter under Rule 39.1 PCT,

- 2.2.2 applications where the description, the claims, or the drawings fail to comply with the prescribed requirements to such an extent that no meaningful search could have been carried out;

- 2.3 claimed subject-matter under Rule 67.1 PCT.

**V. Reasoned statement under Rule 66.2(a)(ii) with regard to novelty, inventive step or industrial applicability**

3. To the extent that the international preliminary examination has been carried out (see item III above), the following is pointed out:

in light of the documents cited in the international search report, it is considered that the invention as claimed in at least one of the independent claims does not appear to meet the criteria mentioned in Article 33 (1) PCT, i.e. does not appear to be novel and/or to involve an inventive step.

4. If amendments are filed, the Applicant must comply with the requirements of Rule 66.8 PCT and indicate the basis in the originally filed application of the amendments made (Article 34 (2) (b) PCT) otherwise these amendments will not be taken into consideration for the establishment of international preliminary examination.  
The attention of the applicant is drawn to the fact that if the application contains an unjustified plurality of independent claims no examination of any of the claims will be carried out.

PATENT COOPERATION TREATY

PCT

REC'D 15 MAR 2002  
PCT

INTERNATIONAL PRELIMINARY EXAMINATION REPORT

(PCT Article 36 and Rule 70)

7

Applicant's or agent's file reference 081513.4	<b>FOR FURTHER ACTION</b> See Notification of Transmittal of International Preliminary Examination Report (Form PCT/IPEA/416)	
International application No. PCT/US 01/ 00418	International filing date (day/month/year) 08/01/2001	Priority date (day/month/year) 07/01/2000
International Patent Classification (IPC) or national classification and IPC H04L1/24		
Applicant AWARE, INC.		

1. This international preliminary examination report has been prepared by this International Preliminary Examining Authority and is transmitted to the applicant according to Article 36.

2. This REPORT consists of a total of 2 sheets, including this cover sheet.

This report is also accompanied by ANNEXES, i.e., sheets of the description, claims and/or drawings which have been amended and are the basis for this report and/or sheets containing rectifications made before this Authority (see Rule 70.16 and Section 607 of the Administrative Instructions under the PCT).

These annexes consists of a total of \_\_\_\_\_ sheets.

3. This report contains indications relating to the following items:

- I  Basis of the report
- II  Priority
- III  Non-establishment of opinion with regard to novelty, inventive step and industrial applicability
- IV  Lack of unity of invention
- V  Reasoned statement under Article 35(2) with regard to novelty, inventive step or industrial applicability; citations and explanations supporting such statement
- VI  Certain documents cited
- VII  Certain defects in the international application
- VIII  Certain observations on the international application

Date of submission of the demand 02/08/2001	Date of completion of this report 09/03/2002
Name and mailing address of the IPEA/  European Patent Office D-80298 Munich Tel. (+49-89) 2399-0, Tx: 523656 epmu d Fax: (+49-89) 2399-4465	Authorized officer VAN DEN BERG J G J Tel. (+49-89) 2399 2828



Form PCT/IPEA/409 (cover sheet) (July 1998)

**I. Basis of the report**

1. The basis of this international preliminary examination report is the application as originally filed.

**III. Non-establishment of opinion with regard to novelty, inventive step and industrial applicability**

2. The question of whether the claimed invention appears to be novel, to involve an inventive step, or to be industrially applicable has not been and will not be the subject of the international preliminary examination (Article 34 (4) (a) (i) (ii) PCT; see also international search report) in respect of:

2.1 Applications having an unnecessary plurality of independent claims (generally not more than 1 independent claim in the same category is necessary; Article 6 PCT);

2.2 unsearched subject-matter (Article 17 (2) (a), Rule 66.1 (e) PCT), e.g.

2.2.1 claimed subject-matter under Rule 39.1 PCT,

2.2.2 applications where the description, the claims, or the drawings fail to comply with the prescribed requirements to such an extent that no meaningful search could have been carried out;

2.3 claimed subject-matter under Rule 67.1 PCT.

**V. Reasoned statement under Article 35(2) with regard to novelty, inventive step or industrial applicability; citations and explanations supporting such statement**

3. To the extent that the international preliminary examination has been carried out (see item III above), the following is pointed out:

In light of the documents cited in the international search report, the invention as claimed in at least one of the independent claims does not appear to meet the criteria mentioned in Article 33 (1) PCT, i.e. does not appear to be novel and/or to involve an inventive step.

ATENT COOPERATION TREATY

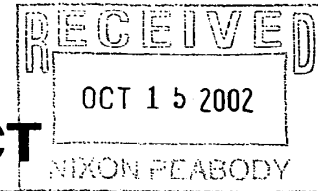

From the INTERNATIONAL SEARCHING AUTHORITY

To:  
 Nixon Peabody LLP  
 Attn. Vick, Jason H.  
 8180 Greensboro Drive, Suite 800  
 McLean, Virginia 22102  
 UNITED STATES OF AMERICA

PCT

NOTIFICATION OF TRANSMITTAL OF  
 THE INTERNATIONAL SEARCH REPORT  
 OR THE DECLARATION

(PCT Rule 44.1)

Date of mailing (day/month/year) 09/10/2002	
Applicant's or agent's file reference 081513-147	<b>FOR FURTHER ACTION</b> See paragraphs 1 and 4 below
International application No. PCT/US 01/ 41653	International filing date (day/month/year) 10/08/2001
Applicant AWARE, INC.	

- The applicant is hereby notified that the International Search Report has been established and is transmitted herewith.  
**Filing of amendments and statement under Article 19:**  
 The applicant is entitled, if he so wishes, to amend the claims of the International Application (see Rule 46):  
  
**When?** The time limit for filing such amendments is normally 2 months from the date of transmittal of the International Search Report; however, for more details, see the notes on the accompanying sheet.  
  
**Where?** Directly to the International Bureau of WIPO  
 34, chemin des Colombettes  
 1211 Geneva 20, Switzerland  
 Facsimile No.: (41-22) 740.14.35  
  
**For more detailed instructions, see the notes on the accompanying sheet.**
- The applicant is hereby notified that no International Search Report will be established and that the declaration under Article 17(2)(a) to that effect is transmitted herewith.
- With regard to the protest** against payment of (an) additional fee(s) under Rule 40.2, the applicant is notified that:
  - the protest together with the decision thereon has been transmitted to the International Bureau together with the applicant's request to forward the texts of both the protest and the decision thereon to the designated Offices.
  - no decision has been made yet on the protest; the applicant will be notified as soon as a decision is made.
- 4. Further action(s):** The applicant is reminded of the following:  
  
 Shortly after **18 months** from the priority date, the international application will be published by the International Bureau. If the applicant wishes to avoid or postpone publication, a notice of withdrawal of the international application, or of the priority claim, must reach the International Bureau as provided in Rules 90bis.1 and 90bis.3, respectively, before the completion of the technical preparations for international publication.  
  
 Within **19 months** from the priority date, a demand for international preliminary examination must be filed if the applicant wishes to postpone the entry into the national phase until 30 months from the priority date (in some Offices even later).  
  
 Within **20 months** from the priority date, the applicant must perform the prescribed acts for entry into the national phase before all designated Offices which have not been elected in the demand or in a later election within 19 months from the priority date or could not be elected because they are not bound by Chapter II.

Name and mailing address of the International Searching Authority  European Patent Office, P.B. 5818 Patentlaan 2 NL-2280 HV Rijswijk Tel. (+31-70) 340-2040, Tx. 31 651 epo nl, Fax: (+31-70) 340-3016	Authorized officer Carina Bergström 10-16-02 DOCKETED By POZ Nixon Peabody, LLP
---	--

Form PCT/ISA/220 (July 1998)

## NOTES TO FORM PCT/ISA/220

These Notes are intended to give the basic instructions concerning the filing of amendments under article 19. The Notes are based on the requirements of the Patent Cooperation Treaty, the Regulations and the Administrative Instructions under that Treaty. In case of discrepancy between these Notes and those requirements, the latter are applicable. For more detailed information, see also the PCT Applicant's Guide, a publication of WIPO.

In these Notes, "Article", "Rule", and "Section" refer to the provisions of the PCT, the PCT Regulations and the PCT Administrative Instructions respectively.

### INSTRUCTIONS CONCERNING AMENDMENTS UNDER ARTICLE 19

The applicant has, after having received the international search report, one opportunity to amend the claims of the international application. It should however be emphasized that, since all parts of the international application (claims, description and drawings) may be amended during the international preliminary examination procedure, there is usually no need to file amendments of the claims under Article 19 except where, e.g. the applicant wants the latter to be published for the purposes of provisional protection or has another reason for amending the claims before international publication. Furthermore, it should be emphasized that provisional protection is available in some States only.

#### What parts of the international application may be amended?

Under Article 19, only the claims may be amended.

During the international phase, the claims may also be amended (or further amended) under Article 34 before the International Preliminary Examining Authority. The description and drawings may only be amended under Article 34 before the International Examining Authority.

Upon entry into the national phase, all parts of the international application may be amended under Article 28 or, where applicable, Article 41.

#### When?

Within 2 months from the date of transmittal of the international search report or 16 months from the priority date, whichever time limit expires later. It should be noted, however, that the amendments will be considered as having been received on time if they are received by the International Bureau after the expiration of the applicable time limit but before the completion of the technical preparations for international publication (Rule 46.1).

#### Where not to file the amendments?

The amendments may only be filed with the International Bureau and not with the receiving Office or the International Searching Authority (Rule 46.2).

Where a demand for international preliminary examination has been/is filed, see below.

#### How?

Either by cancelling one or more entire claims, by adding one or more new claims or by amending the text of one or more of the claims as filed.

A replacement sheet must be submitted for each sheet of the claims which, on account of an amendment or amendments, differs from the sheet originally filed.

All the claims appearing on a replacement sheet must be numbered in Arabic numerals. Where a claim is cancelled, no renumbering of the other claims is required. In all cases where claims are renumbered, they must be renumbered consecutively (Administrative Instructions, Section 205(b)).

The amendments must be made in the language in which the international application is to be published.

#### What documents must/may accompany the amendments?

##### Letter (Section 205(b)):

The amendments must be submitted with a letter.

The letter will not be published with the international application and the amended claims. It should not be confused with the "Statement under Article 19(1)" (see below, under "Statement under Article 19(1)").

The letter must be in English or French, at the choice of the applicant. However, if the language of the international application is English, the letter must be in English; if the language of the international application is French, the letter must be in French.

## NOTES TO FORM PCT/ISA/220 (continued)

The letter must indicate the differences between the claims as filed and the claims as amended. It must, in particular, indicate, in connection with each claim appearing in the international application (it being understood that identical indications concerning several claims may be grouped), whether

- (i) the claim is unchanged;
- (ii) the claim is cancelled;
- (iii) the claim is new;
- (iv) the claim replaces one or more claims as filed;
- (v) the claim is the result of the division of a claim as filed.

The following examples illustrate the manner in which amendments must be explained in the accompanying letter:

1. [Where originally there were 48 claims and after amendment of some claims there are 51]:  
"Claims 1 to 29, 31, 32, 34, 35, 37 to 48 replaced by amended claims bearing the same numbers; claims 30, 33 and 36 unchanged; new claims 49 to 51 added."
2. [Where originally there were 15 claims and after amendment of all claims there are 11]:  
"Claims 1 to 15 replaced by amended claims 1 to 11."
3. [Where originally there were 14 claims and the amendments consist in cancelling some claims and in adding new claims]:  
"Claims 1 to 6 and 14 unchanged; claims 7 to 13 cancelled; new claims 15, 16 and 17 added." or  
"Claims 7 to 13 cancelled; new claims 15, 16 and 17 added; all other claims unchanged."
4. [Where various kinds of amendments are made]:  
"Claims 1-10 unchanged; claims 11 to 13, 18 and 19 cancelled; claims 14, 15 and 16 replaced by amended claim 14; claim 17 subdivided into amended claims 15, 16 and 17; new claims 20 and 21 added."

### "Statement under article 19(1)" (Rule 46.4)

The amendments may be accompanied by a statement explaining the amendments and indicating any impact that such amendments might have on the description and the drawings (which cannot be amended under Article 19(1)).

The statement will be published with the international application and the amended claims.

It must be in the language in which the international application is to be published.

It must be brief, not exceeding 500 words if in English or if translated into English.

It should not be confused with and does not replace the letter indicating the differences between the claims as filed and as amended. It must be filed on a separate sheet and must be identified as such by a heading, preferably by using the words "Statement under Article 19(1)."

It may not contain any disparaging comments on the international search report or the relevance of citations contained in that report. Reference to citations, relevant to a given claim, contained in the international search report may be made only in connection with an amendment of that claim.

### Consequence if a demand for international preliminary examination has already been filed

If, at the time of filing any amendments under Article 19, a demand for international preliminary examination has already been submitted, the applicant must preferably, at the same time of filing the amendments with the International Bureau, also file a copy of such amendments with the International Preliminary Examining Authority (see Rule 62.2(a), first sentence).

### Consequence with regard to translation of the international application for entry into the national phase

The applicant's attention is drawn to the fact that, where upon entry into the national phase, a translation of the claims as amended under Article 19 may have to be furnished to the designated/elected Offices, instead of, or in addition to, the translation of the claims as filed.

For further details on the requirements of each designated/elected Office, see Volume II of the PCT Applicant's Guide.

**PATENT COOPERATION TREATY**

**PCT**

**INTERNATIONAL SEARCH REPORT**

(PCT Article 18 and Rules 43 and 44)

Applicant's or agent's file reference <b>081513-147</b>	<b>FOR FURTHER ACTION</b>		see Notification of Transmittal of International Search Report (Form PCT/ISA/220) as well as, where applicable, Item 5 below.
International application No. <b>PCT/US 01/41653</b>	International filing date (day/month/year) <b>10/08/2001</b>	(Earliest) Priority Date (day/month/year) <b>10/08/2000</b>	
Applicant <b>AWARE, INC.</b>			

This International Search Report has been prepared by this International Searching Authority and is transmitted to the applicant according to Article 18. A copy is being transmitted to the International Bureau.

This International Search Report consists of a total of 4 sheets.

It is also accompanied by a copy of each prior art document cited in this report.

**1. Basis of the report**

a. With regard to the **language**, the international search was carried out on the basis of the international application in the language in which it was filed, unless otherwise indicated under this item.

the international search was carried out on the basis of a translation of the international application furnished to this Authority (Rule 23.1(b)).

b. With regard to any **nucleotide and/or amino acid sequence** disclosed in the international application, the international search was carried out on the basis of the sequence listing:

contained in the international application in written form.

filed together with the international application in computer readable form.

furnished subsequently to this Authority in written form.

furnished subsequently to this Authority in computer readable form.

the statement that the subsequently furnished written sequence listing does not go beyond the disclosure in the international application as filed has been furnished.

the statement that the information recorded in computer readable form is identical to the written sequence listing has been furnished.

2.  **Certain claims were found unsearchable** (See Box I).

3.  **Unity of invention is lacking** (see Box II).

4. With regard to the **title**,

the text is approved as submitted by the applicant.

the text has been established by this Authority to read as follows:

**SYSTEMS AND METHODS FOR CHARACTERIZING TRANSMISSION LINES IN A MULTI-CARRIER DSL ENVIRONMENT**

5. With regard to the **abstract**,

the text is approved as submitted by the applicant.

the text has been established, according to Rule 38.2(b), by this Authority as it appears in Box III. The applicant may, within one month from the date of mailing of this international search report, submit comments to this Authority.

6. The figure of the **drawings** to be published with the abstract is Figure No.

as suggested by the applicant.

because the applicant failed to suggest a figure.

because this figure better characterizes the invention.

1  
 None of the figures.



INTERNATIONAL SEARCH REPORT

International Application No  
PCT/US 01/41653

<b>A. CLASSIFICATION OF SUBJECT MATTER</b> IPC 7 H04B3/46 H04L27/26		
According to International Patent Classification (IPC) or to both national classification and IPC		
<b>B. FIELDS SEARCHED</b> Minimum documentation searched (classification system followed by classification symbols) IPC 7 H04L H04B		
Documentation searched other than minimum documentation to the extent that such documents are included in the fields searched		
Electronic data base consulted during the international search (name of data base and, where practical, search terms used) EPO-Internal, WPI Data, PAJ, INSPEC		
<b>C. DOCUMENTS CONSIDERED TO BE RELEVANT</b>		
Category *	Citation of document, with indication, where appropriate, of the relevant passages	Relevant to claim No.
X	US 6 075 821 A (CHEN CHUNTA ET AL) 13 June 2000 (2000-06-13) abstract column 6, line 24 - line 29 column 11, line 4 - line 14 claim 1	1,2
A	---	3-57
A	WO 99 63427 A (GTE LABORATORIES INC) 9 December 1999 (1999-12-09) the whole document	1-57
A	EP 0 889 615 A (INTEGRATED TELECOM EXPRESS) 7 January 1999 (1999-01-07) abstract page 4, line 12 - line 13 page 4, line 53 -page 5, line 3 claims 40-53 ---	1-57
	-/--	
<input checked="" type="checkbox"/> Further documents are listed in the continuation of box C. <input checked="" type="checkbox"/> Patent family members are listed in annex.		
* Special categories of cited documents:		
*A* document defining the general state of the art which is not considered to be of particular relevance *E* earlier document but published on or after the international filing date *L* document which may throw doubts on priority claim(s) or which is cited to establish the publication date of another citation or other special reason (as specified) *O* document referring to an oral disclosure, use, exhibition or other means *P* document published prior to the international filing date but later than the priority date claimed		*T* later document published after the international filing date or priority date and not in conflict with the application but cited to understand the principle or theory underlying the invention *X* document of particular relevance; the claimed invention cannot be considered novel or cannot be considered to involve an inventive step when the document is taken alone *Y* document of particular relevance; the claimed invention cannot be considered to involve an inventive step when the document is combined with one or more other such documents, such combination being obvious to a person skilled in the art. *&* document member of the same patent family
Date of the actual completion of the international search 26 September 2002		Date of mailing of the international search report 09/10/2002
Name and mailing address of the ISA European Patent Office, P.B. 5818 Patentlaan 2 NL - 2280 HV Rijswijk Tel. (+31-70) 340-2040, Tx. 31 651 epo nl, Fax: (+31-70) 340-3016		Authorized officer Reilly, D

INTERNATIONAL SEARCH REPORT

International Application No  
PCT/US 01/41653

C.(Continuation) DOCUMENTS CONSIDERED TO BE RELEVANT		
Category *	Citation of document, with indication, where appropriate, of the relevant passages	Relevant to claim No.
A	US 5 128 619 A (BJORK ROGER A ET AL) ✓ 7 July 1992 (1992-07-07) the whole document	1-57

*cited  
in  
US*

1

**INTERNATIONAL SEARCH REPORT**

Information on patent family members

International Application No  
PCT/US 01/41653

Patent document cited in search report		Publication date	Patent family member(s)	Publication date
US 6075821	A	13-06-2000	NONE	
WO 9963427	A	09-12-1999	US 6292539 B1 AU 4087599 A EP 1093609 A1 WO 9963427 A1	18-09-2001 20-12-1999 25-04-2001 09-12-1999
EP 0889615	A	07-01-1999	US 6252900 B1 EP 0889615 A2 JP 11088920 A US 6088385 A US 2001007574 A1 US 6442195 B1	26-06-2001 07-01-1999 30-03-1999 11-07-2000 12-07-2001 27-08-2002
✓ US 5128619	A	07-07-1992	EP 0391312 A2 JP 2292919 A	10-10-1990 04-12-1990

## Electronic Acknowledgement Receipt

<b>EFS ID:</b>	12827617
<b>Application Number:</b>	13476310
<b>International Application Number:</b>	
<b>Confirmation Number:</b>	7896
<b>Title of Invention:</b>	Multicarrier Modulation Messaging for Power Level Per Subchannel Information
<b>First Named Inventor/Applicant Name:</b>	David M. Krinsky
<b>Customer Number:</b>	62574
<b>Filer:</b>	Jason Vick/Joanne Vos
<b>Filer Authorized By:</b>	Jason Vick
<b>Attorney Docket Number:</b>	5550-2-CON2-1-4
<b>Receipt Date:</b>	21-MAY-2012
<b>Filing Date:</b>	
<b>Time Stamp:</b>	16:54:09
<b>Application Type:</b>	Utility under 35 USC 111(a)

### Payment information:

Submitted with Payment	no
------------------------	----

### File Listing:

Document Number	Document Description	File Name	File Size(Bytes)/ Message Digest	Multi Part /.zip	Pages (if appl.)
1		IDS_01.pdf	1021277 0e210adfb99fa964bb5b061603c4f5b47f6e1f1	yes	9

Multipart Description/PDF files in .zip description					
Document Description			Start	End	
Transmittal Letter			1	3	
Information Disclosure Statement (IDS) Form (SB08)			4	9	
<b>Warnings:</b>					
<b>Information:</b>					
2	Foreign Reference	EP0889615A2.pdf	1848555	no	34
			931838aa76d186918d6307adbfea64690a80e368		
<b>Warnings:</b>					
<b>Information:</b>					
3	Foreign Reference	GB2303032A.pdf	775828	no	24
			971ccd21e6ca715331e9fd91a66779a4b3d7a218		
<b>Warnings:</b>					
<b>Information:</b>					
4	Foreign Reference	JP_Hei6_1994-003956.pdf	1192136	no	15
			798b375a7605b669bc529b15224f19aaa9624e95		
<b>Warnings:</b>					
<b>Information:</b>					
5	Foreign Reference	JP10513622T.pdf	3431375	no	145
			888b9862465b4615c95ce831cee3890f52d0c1ea		
<b>Warnings:</b>					
<b>Information:</b>					
6	Foreign Reference	JP11261665A.pdf	927635	no	19
			0b267676de77d33ea96127e2aca0835b068a853a3		
<b>Warnings:</b>					
<b>Information:</b>					
7	Foreign Reference	JP11317723A.pdf	496196	no	12
			9325e42f205153269dbd09ce442548989ba d2c17		
<b>Warnings:</b>					
<b>Information:</b>					
8	Foreign Reference	JP11508417T.pdf	1164326	no	47
			a3796003ff4abfa9d2bcb96f0ab15f9a5a117ff		
<b>Warnings:</b>					
<b>Information:</b>					

9	Foreign Reference	WO0064130A2.pdf	2380836 8a0213e66164e2b763e631da8dd091e1e12e61f7	no	74
<b>Warnings:</b>					
<b>Information:</b>					
10	Foreign Reference	WO8607223.pdf	2305273 3376921f387058b8b4d2f445ed88e8b477016982	no	53
<b>Warnings:</b>					
<b>Information:</b>					
11	Foreign Reference	WO9624995.pdf	5035736 f6a6515109baa2571c885c5737c2b63730ca0664	no	129
<b>Warnings:</b>					
<b>Information:</b>					
12	Foreign Reference	WO9701256.pdf	2140797 8486ac07b78039bab32b797c8b74a45ca8143369	no	53
<b>Warnings:</b>					
<b>Information:</b>					
13	Foreign Reference	WO9701900A1.pdf	1066593 32287592098a865152b537c1ac279cda6fd0999a	no	20
<b>Warnings:</b>					
<b>Information:</b>					
14	Foreign Reference	WO99020027.pdf	3477643 e650eb00032386da3e9b5646deca940758b888d8	no	71
<b>Warnings:</b>					
<b>Information:</b>					
15	Foreign Reference	WO9926375A2.pdf	1458669 94f3868d54ccceb0cb19877c8e7fb749b6637ff7	no	31
<b>Warnings:</b>					
<b>Information:</b>					
16	Foreign Reference	WO9963427A1.pdf	986542 d3d96d3f5cccc62ca2d9be876b4e36d6198fc3662	no	23
<b>Warnings:</b>					
<b>Information:</b>					
17	Foreign Reference	WO9967890A1.pdf	1092195 201646c9374aee2813049e34385b2b5638721d80	no	25
<b>Warnings:</b>					
<b>Information:</b>					

18	Non Patent Literature	Boets_Modeling_Aspect_of_Transmission_Line_Networks.pdf	399671 e5aabc3c165da136812ac990d82068488564dd13	no	6
<b>Warnings:</b>					
<b>Information:</b>					
19	Non Patent Literature	Cioffi_ADSL_Maintenance_with_DMT_T1E1_4.pdf	764298 a24c4bf9425f10d9789e1f0110fe4fc5429b31c4	no	14
<b>Warnings:</b>					
<b>Information:</b>					
20	Foreign Reference	Lewis_Extending_Trouble_Ticket_System_to_Fault_Diagnostics.pdf	801049 16aff63faa90c450f6cb78fdb03c7a26a49d0499	no	8
<b>Warnings:</b>					
<b>Information:</b>					
21	Non Patent Literature	Asymmetric_digital_subscriber_line_G992-1_pp_91-117_125-26_131-32.pdf	1964875 7f39e2c53e65d003a7fa787f897913ba5801c5e9	no	33
<b>Warnings:</b>					
<b>Information:</b>					
22	Non Patent Literature	ITU- T_Recommendation_G992-2_06-1999.pdf	20989447 720d0b31fca353c8b3c0d1fa8a36d25b83e9e2cc	no	179
<b>Warnings:</b>					
<b>Information:</b>					
23	Non Patent Literature	ITU- T_Recommendation_G994-1_06-1999.pdf	2054195 5cf135f4d19cc6d2da72898847ceaad36de464d2	no	56
<b>Warnings:</b>					
<b>Information:</b>					
24	Non Patent Literature	5550-2-PCT_Search_Report_07-16-2001.pdf	156202 ce80d36e54318f42cd19132342bee0ba2645a706	no	4
<b>Warnings:</b>					
<b>Information:</b>					
25	Non Patent Literature	5550-2-PCT_Written_Opinion_01-18-2002.pdf	241613 635fc12cf9d6917802d2146cce503dd896125fe7	no	2
<b>Warnings:</b>					
<b>Information:</b>					
26	Non Patent Literature	5550-2-PCT_IPER_03-09-2002.pdf	85503 dfb67c85e9bdcc84d0df1b969e85eacfbec0d83	no	2
<b>Warnings:</b>					
<b>Information:</b>					

27	Non Patent Literature	5550-2-PCT-3_ISR_10-09-2002.pdf	317805 e4fa2a16e2e4ad6137d45548074d851dd1b83abd	no	7
<b>Warnings:</b>					
<b>Information:</b>					
28	Non Patent Literature	5550-2-PAU_OA_4-2-04.pdf	56750 0d254394024b482c9a66a3be9b3129ecfed146fc	no	1
<b>Warnings:</b>					
<b>Information:</b>					
29	Non Patent Literature	5550-2-PAU_NOA_08-06-2004.pdf	153276 9c568431ccf10573b1f11ca68419242b1befe1a4	no	2
<b>Warnings:</b>					
<b>Information:</b>					
30	Non Patent Literature	5550-2-PAU-4_OA_11-16-06.pdf	131297 4ff0b79b6b7c7cdcb00e51ab03715623ad52424	no	2
<b>Warnings:</b>					
<b>Information:</b>					
31	Non Patent Literature	5550-2-PAU-4_NOA_2008-08-07.pdf	161415 8ae89246eb5c72cd735c7e75bf75ff0d03f1400e	no	2
<b>Warnings:</b>					
<b>Information:</b>					
32	Non Patent Literature	5550-2-PAU-4-DIV_OA_03-09-2009.pdf	72889 2f41e077d06ead84bb4e4b1ab9c984ffadeea72	no	2
<b>Warnings:</b>					
<b>Information:</b>					
33	Non Patent Literature	5550-2-PAU-4-DIV_NOA_07-09-2009.pdf	64074 314f5bda4dc26bc9ae7148ce5c7b16d51d700128	no	2
<b>Warnings:</b>					
<b>Information:</b>					
34	Non Patent Literature	5550-2-PAU-4-DIV-2_OA_03-21-2011.pdf	106842 6f212e59c6e2bad87b6e7e3285e60831a2b8092e	no	2
<b>Warnings:</b>					
<b>Information:</b>					
35	Non Patent Literature	5550-2-PAU-4-DIV-2_OA_2011-05-27.pdf	103544 62f1a7c8f81b79b09ed0f9df60207cb31ad0bff6	no	2
<b>Warnings:</b>					
<b>Information:</b>					



36	Non Patent Literature	5550-2-PAU-4-DIV_2_NOA_2011-08-25.pdf	114178 c37e9ded1fad2bc51b89c52910ec41bc550c8108	no	3
<b>Warnings:</b>					
<b>Information:</b>					
37	Non Patent Literature	5550-2-PCA_OA_11-24-2009.pdf	55806 5c821fd147f6f958641910c85b7056ed2845f44	no	2
<b>Warnings:</b>					
<b>Information:</b>					
38	Non Patent Literature	5550-2-PCA_NOA_7-16-2010.pdf	118093 38e44f1143482f8af07bd19d1137d6b8bab2e8f	no	1
<b>Warnings:</b>					
<b>Information:</b>					
39	Non Patent Literature	5550-2-PCA-DIV_OA_2011-06-30.pdf	216248 97416c585f79a12f2f2fb268156c6b02d3fc37b	no	2
<b>Warnings:</b>					
<b>Information:</b>					
40	Non Patent Literature	5550-2-PCA-DIV_NOA_03-01-2012.pdf	167830 76e1c56f487e8e86d57cadea83030e4fea25e	no	1
<b>Warnings:</b>					
<b>Information:</b>					
41	Non Patent Literature	5550-2-PEP_OA_12-01-2004.pdf	143351 c0d67e7101c9b24ab6ba46b14594788294b2b3fe	no	4
<b>Warnings:</b>					
<b>Information:</b>					
42	Non Patent Literature	5550-2-PEP_OA_09-14-2005.pdf	52815 b7ea017eecefd028e413830faf6689cdbc0caf	no	2
<b>Warnings:</b>					
<b>Information:</b>					
43	Non Patent Literature	5550-2-PEP_NOA_05-15-2006.pdf	1363474 b9ad07b60b6f0b36ae3759ea08b3e30e52ed522	no	25
<b>Warnings:</b>					
<b>Information:</b>					
44	Non Patent Literature	5550-2-PEP-5_ESR_1-08-2007.pdf	696810 9ae058a5710f5b8d193a484700c79ac3032c01db	no	8
<b>Warnings:</b>					
<b>Information:</b>					

45	Non Patent Literature	5550-2-PEP-5_OA_09-20-2007.pdf	29688 3e16a01427c0481693c66e877c0b80bf723cd4c	no	1
<b>Warnings:</b>					
<b>Information:</b>					
46	Non Patent Literature	5550-2-PEP-5_OA_04-23-10.pdf	256735 fddbff1ef2c803a4fdb6dbb178541cf1968032a84	no	9
<b>Warnings:</b>					
<b>Information:</b>					
47	Non Patent Literature	5550-2-PEP-5_OA_07-07-2010.pdf	201750 75445cd31ff7e634d4b646b759e8ed0ca88f17e	no	7
<b>Warnings:</b>					
<b>Information:</b>					
48	Non Patent Literature	5550-2-PEP-5_Communication_713EP_C_04-04-2011.pdf	1118938 aa1de93f8b730f2a5ac628b3f1b4ddd492d25ad3	no	24
<b>Warnings:</b>					
<b>Information:</b>					
49	Non Patent Literature	5550-2-PJP_OA_12-07-2009.pdf	325581 9bb7afb456a2a1034a70d0efb7055792dbeedbfd	no	8
<b>Warnings:</b>					
<b>Information:</b>					
50	Non Patent Literature	5550-2-PJP_OA_08-02-2010.pdf	192775 2dacdecdb0b27030faefc5d08a9487bf45e0bcff	no	6
<b>Warnings:</b>					
<b>Information:</b>					
51	Non Patent Literature	5550-2-PJP_OA_03-28-2011.pdf	114068 48ce0363891e3a5647f48f8237ea92b78a70edf9	no	4
<b>Warnings:</b>					
<b>Information:</b>					
52	Non Patent Literature	5550-2-PJP-DIV_OA_7-26-10.pdf	98046 82fd899db7ff646954b8fc12899a361483450913	no	5
<b>Warnings:</b>					
<b>Information:</b>					
53	Non Patent Literature	5550-2-PJP-DIV_NOA_03-14-2011.pdf	75106 82d1c244f8a90e4e89ba3665bc16df1c81728853	no	3
<b>Warnings:</b>					
<b>Information:</b>					

54	Non Patent Literature	5550-2-PKR_NOA_12-1-06.pdf	112458 f51253e094455b82ddcfda340ca66f0571d844f4	no	3
<b>Warnings:</b>					
<b>Information:</b>					
55	Non Patent Literature	5550-2_OA_2002-06-20.pdf	520919 89434121207e74641356e47c21b645c1957e7400	no	6
<b>Warnings:</b>					
<b>Information:</b>					
56	Non Patent Literature	5550-2_OA_2002-09-24.pdf	536559 38636095cd805b446dcae8c508b48479faabdcf1	no	6
<b>Warnings:</b>					
<b>Information:</b>					
57	Non Patent Literature	5550-2_OA_2003-03-14.pdf	576265 3e1fdb159c760036e282d5f8b0147bbadd2c5155	no	7
<b>Warnings:</b>					
<b>Information:</b>					
58	Non Patent Literature	5550-2_NOA_2003-07-01.pdf	657680 8fbcdd685998e2650cb2293c68432a950407e251	no	7
<b>Warnings:</b>					
<b>Information:</b>					
59	Non Patent Literature	5550-2-CON2_OA_10-31-06.pdf	445804 827c1498a2c2471307385d437484d38a253000e6	no	14
<b>Warnings:</b>					
<b>Information:</b>					
<b>Total Files Size (in bytes):</b>			67617334		

This Acknowledgement Receipt evidences receipt on the noted date by the USPTO of the indicated documents, characterized by the applicant, and including page counts, where applicable. It serves as evidence of receipt similar to a Post Card, as described in MPEP 503.

**New Applications Under 35 U.S.C. 111**

If a new application is being filed and the application includes the necessary components for a filing date (see 37 CFR 1.53(b)-(d) and MPEP 506), a Filing Receipt (37 CFR 1.54) will be issued in due course and the date shown on this Acknowledgement Receipt will establish the filing date of the application.

**National Stage of an International Application under 35 U.S.C. 371**

If a timely submission to enter the national stage of an international application is compliant with the conditions of 35 U.S.C. 371 and other applicable requirements a Form PCT/DO/EO/903 indicating acceptance of the application as a national stage submission under 35 U.S.C. 371 will be issued in addition to the Filing Receipt, in due course.

**New International Application Filed with the USPTO as a Receiving Office**

If a new international application is being filed and the international application includes the necessary components for an international filing date (see PCT Article 11 and MPEP 1810), a Notification of the International Application Number and of the International Filing Date (Form PCT/RO/105) will be issued in due course, subject to prescriptions concerning national security, and the date shown on this Acknowledgement Receipt will establish the international filing date of the application.

IN THE UNITED STATES PATENT AND TRADEMARK OFFICE

In Re the Application of: ) Group Art Unit:  
David M. Krinsky et al. ) Confirmation No.: 7896  
Serial No.: 13/476,310 ) Examiner:  
Filed: May 21, 2012 )  
Atty. File No.: 5550-2-CON2-1-4 ) INFORMATION DISCLOSURE  
Entitled: "MULTICARRIER MODULATION ) STATEMENT  
MESSAGING FOR POWER LEVEL PER )  
SUBCHANNEL INFORMATION" ) Electronically Submitted

Commissioner for Patents  
P.O. Box 1450  
Alexandria, VA 22313-1450

Dear Sir:

The references cited on attached Form PTO-1449 are being called to the attention of the Examiner.

- Copies of the cited non-patent and/or foreign references are enclosed herewith.
- Copies of the cited U.S. patents and/or patent applications are enclosed herewith.
- Copies of the cited U.S. patents/patent application publications are not enclosed in accordance with 37 C.F.R. § 1.98(a).
- Copies of the cited references are not enclosed, in accordance with 37 C.F.R. § 1.98(d), because the references were cited by or submitted to the U.S. Patent and Trademark Office in prior application Serial No. \_\_\_\_\_ filed \_\_\_\_\_, which is relied upon for an earlier filing date under 35 U.S.C. § 120.
- To the best of applicants' belief, the pertinence of the foreign-language references are believed to be summarized in the attached English translation/abstracts and/or in the figures, although applicants do not necessarily vouch for the accuracy of the translation.
- Examiner's attention is drawn to the following related applications:
  - Serial No. 09/755,173 filed 01-08-2001, now U.S. Patent No. 6,658,052 (Attorney's Ref. No. 5550-2)
  - Serial No. 10/619,691 filed 07-16-2003, now U.S. Patent No. 7,570,686 (Attorney's Ref. No. 5550-2-CON-2)
  - Serial No. 12/477,742 filed 06-03-2009, now U.S. Patent No. 7,835,430 (Attorney's Ref. No. 5550-2-CON-2-1)
  - Serial No. 12/779,660 filed 05-13-2010 (Attorney's Ref. No. 5550-2-CON-2-1-1)

- Serial No. 12/779,708 filed 05-13-2010, now U.S. Patent No. 7,889,784 (Attorney Ref. No. 5550-2-CON-2-1-2)
- Serial No. 13/004,254 filed 01-11-2011, (Attorney Ref. No. 5550-2-CON-2-1-3)

Other: \_\_\_\_\_

Submission of the above information is not intended as an admission that any item is citable under the statutes or rules to support a rejection, that any item disclosed represents analogous art, or that those skilled in the art would refer to or recognize the pertinence of any reference without the benefit of hindsight, nor should an inference be drawn as to the pertinence of the references based on the order in which they are presented. Submission of this statement should not be taken as an indication that a search has been conducted, or that no better art exists.

It is respectfully requested that the cited information be expressly considered during the prosecution of this application and the references made of record therein.

**FEES**

<input checked="" type="checkbox"/>	<p><b>37 CFR 1.97(b):</b> No fee is believed due in connection with this submission, because the information disclosure statement submitted herewith is satisfied by one of the following conditions ("X" indicates satisfaction):</p> <p><input type="checkbox"/> Within three months of the filing date of a national application other than a continued prosecution application under 37 CFR 1.53(d), or</p> <p><input type="checkbox"/> Within three months of the date of entry into the national stage of an international application as set forth in 37 CFR 1.491 or</p> <p><input checked="" type="checkbox"/> Before the mailing date of a first Office Action on the merits, or</p> <p><input type="checkbox"/> Before the mailing of a first Office action after the filing of a request for continued examination under 37 CFR 1.114.</p> <p>Although no fee is believed due, if any fee is deemed due in connection with this submission, please charge such fee to Deposit Account 19-1970.</p>
<input type="checkbox"/>	<p><b>37 CFR 1.97(c):</b> The information disclosure statement transmitted herewith is being filed after all the above conditions (37 CFR 1.97(b)), but before the mailing date of one of the following conditions:</p> <p>(1) a final action under 37 C.F.R. 1.113 or</p> <p>(2) a notice of allowance under 37 C.F.R. 1.311, or</p> <p>(3) an action that otherwise closes prosecution in the application.</p> <p>This Information Disclosure Statement is accompanied by:</p> <p><input type="checkbox"/> A Certification (below) as specified by 37 C.F.R. 1.97(e). Although no fee is believed due, if any fee is deemed due in connection with this submission, please charge such fee to Deposit Account 19-1970.</p> <p style="text-align: center;">OR</p> <p><input type="checkbox"/> Please charge Deposit Account 19-1970 in the amount of \$180.00 for the fee set forth in 37 C.F.R. 1.17(p) for submission of an information disclosure statement. Please credit any overpayment or charge any underpayment to Deposit Account 19-1970.</p>
<input type="checkbox"/>	<p><b>37 CFR 1.97(d):</b> This Information Disclosure Statement is being submitted after the period specified in 37 CFR 1.97(c).</p> <p><input type="checkbox"/> This information Disclosure Statement includes a Certification (below) as specified by 37 C.F.R. 1.97(e)</p> <p style="text-align: center;">AND</p> <p><input type="checkbox"/> Applicants hereby requests consideration of the reference(s) disclosed herein. Please charge Deposit Account 19-1970 in the amount of \$180.00 under 37 C.F.R. 1.17(p). Please credit any overpayment or charge any underpayment to Deposit Account 19-1970. Election to pay the fee should not be taken as an indication that applicant(s) cannot execute a certification.</p>

**Certification (37 C.F.R. 1.97(e))**  
(Applicable only if checked)

- The undersigned certifies that:
- Each item of information contained in this information disclosure statement was first cited in any communication from a foreign patent office in a counterpart foreign application not more than three months prior to the filing of this statement. 37 C.F.R. 1.97(e)(1).
  - A copy of the communication from the foreign patent office is enclosed.

OR

- No item of information contained in this information disclosure statement was cited in a communication from a foreign patent office in a counterpart foreign application, and, to the knowledge of the undersigned after making reasonable inquiry, no item of information contained in this Information Disclosure Statement was known to any individual designated in 37 C.F.R. 1.56(c) more than three months prior to the filing of this statement. 37 C.F.R. 1.97(e)(2).

Respectfully submitted,

SHERIDAN ROSS P.C.

By: \_\_\_\_\_

Jason H. Vick  
Registration No. 45,285  
1560 Broadway, Suite 1200  
Denver, Colorado 80202-5141  
(303) 863-9700

Date: 21 MAR '12

## Electronic Acknowledgement Receipt

<b>EFS ID:</b>	12827754
<b>Application Number:</b>	13476310
<b>International Application Number:</b>	
<b>Confirmation Number:</b>	7896
<b>Title of Invention:</b>	Multicarrier Modulation Messaging for Power Level Per Subchannel Information
<b>First Named Inventor/Applicant Name:</b>	David M. Krinsky
<b>Customer Number:</b>	62574
<b>Filer:</b>	Jason Vick/Joanne Vos
<b>Filer Authorized By:</b>	Jason Vick
<b>Attorney Docket Number:</b>	5550-2-CON2-1-4
<b>Receipt Date:</b>	21-MAY-2012
<b>Filing Date:</b>	
<b>Time Stamp:</b>	17:00:19
<b>Application Type:</b>	Utility under 35 USC 111(a)

### Payment information:

Submitted with Payment	no
------------------------	----

### File Listing:

Document Number	Document Description	File Name	File Size(Bytes)/ Message Digest	Multi Part /.zip	Pages (if appl.)
1	Non Patent Literature	5550-2-CON2_OA_3-30-07.pdf	360505 <small>4ce2475f7f74d4ada41e93c92148c62342aff556</small>	no	11

### Warnings:

### Information:



2	Non Patent Literature	5550-2-CON2_OA_6-13-08.pdf	213633 ed7c5e64d3a07730a9d7fc9c2afbdccde49ba669	no	7
<b>Warnings:</b>					
<b>Information:</b>					
3	Non Patent Literature	5550-2-CON2_OA_10-20-08.pdf	359739 90f874c16321df138cd6d83e72f2ad7a8e4f6326f	no	11
<b>Warnings:</b>					
<b>Information:</b>					
4	Non Patent Literature	5550-2-CON2_NOA_5-15-09.pdf	362420 987db7c0dac929d6ae5d51f6d6969fd44979705b	no	9
<b>Warnings:</b>					
<b>Information:</b>					
5	Non Patent Literature	5550-2-CON2_NOA_7-6-09.pdf	150837 0cb7376cb0f55ea05c0329c1c04eec596e57c1b	no	5
<b>Warnings:</b>					
<b>Information:</b>					
6	Non Patent Literature	5550-2-CON-2-1_OA_6-8-10.pdf	259257 8c903cf125fe9e6419c26fc455ee9ad21d1a0978	no	10
<b>Warnings:</b>					
<b>Information:</b>					
7	Non Patent Literature	5550-2-CON-2-1_OA_8-16-2010.pdf	276638 f1aea1062a745a083380b37983d3e918534d7445	no	9
<b>Warnings:</b>					
<b>Information:</b>					
8	Non Patent Literature	5550-2-CON-2-1_NOA_9-7-2010.pdf	233606 0ea357de0860423aa38eb68f87b67ed183f368e0	no	6
<b>Warnings:</b>					
<b>Information:</b>					
9	Non Patent Literature	5550-2-CON-2-1-1_OA_03-19-2012.pdf	3743974 f14f34492d5f38c7993ce0458c48847ec71d5028	no	53
<b>Warnings:</b>					
<b>Information:</b>					
10	Non Patent Literature	5550-2-CON-2-1-1_NOA_04-26-2012.pdf	497670 67010a3f0340b988a8c2440247560730b5d5e01b	no	12
<b>Warnings:</b>					
<b>Information:</b>					

11	Non Patent Literature	5550-2- CON-2-1-2_OA_9-29-2010.pdf	196746 b0dce94939b1cd715782760bf2cab707e98 27a6d	no	6
<b>Warnings:</b>					
<b>Information:</b>					
12	Non Patent Literature	5550-2- CON-2-1-2_OA_12-15-2010.pdf	204798 f4fcdce4825b75e45ab00de267c823f5cd33 0172	no	6
<b>Warnings:</b>					
<b>Information:</b>					
13	Non Patent Literature	5550-2- CON-2-1-2_NOA_1-3-2011.pdf	227245 601da178e4f6e431bcd8647d65982b5b600 6dfcb	no	6
<b>Warnings:</b>					
<b>Information:</b>					
<b>Total Files Size (in bytes):</b>			7087068		
<p>This Acknowledgement Receipt evidences receipt on the noted date by the USPTO of the indicated documents, characterized by the applicant, and including page counts, where applicable. It serves as evidence of receipt similar to a Post Card, as described in MPEP 503.</p> <p><b><u>New Applications Under 35 U.S.C. 111</u></b>  If a new application is being filed and the application includes the necessary components for a filing date (see 37 CFR 1.53(b)-(d) and MPEP 506), a Filing Receipt (37 CFR 1.54) will be issued in due course and the date shown on this Acknowledgement Receipt will establish the filing date of the application.</p> <p><b><u>National Stage of an International Application under 35 U.S.C. 371</u></b>  If a timely submission to enter the national stage of an international application is compliant with the conditions of 35 U.S.C. 371 and other applicable requirements a Form PCT/DO/EO/903 indicating acceptance of the application as a national stage submission under 35 U.S.C. 371 will be issued in addition to the Filing Receipt, in due course.</p> <p><b><u>New International Application Filed with the USPTO as a Receiving Office</u></b>  If a new international application is being filed and the international application includes the necessary components for an international filing date (see PCT Article 11 and MPEP 1810), a Notification of the International Application Number and of the International Filing Date (Form PCT/RO/105) will be issued in due course, subject to prescriptions concerning national security, and the date shown on this Acknowledgement Receipt will establish the international filing date of the application.</p>					

Under the Paperwork Reduction Act of 1996, no persons are required to respond to a collection of information unless it displays a valid OMB control number.

**POWER OF ATTORNEY TO PROSECUTE APPLICATIONS BEFORE THE USPTO**

I hereby revoke all previous powers of attorney given in the application identified in the attached statement under 37 CFR 3.73(b).

I hereby appoint:

 Practitioners associated with the Customer Number: 

OR

 Practitioner(s) named below (if more than ten patent practitioners are to be named, then a customer number must be used):

Name	Registration Number	Name	Registration Number

as attorney(s) or agent(s) to represent the undersigned before the United States Patent and Trademark Office (USPTO) in connection with any and all patent applications assigned only to the undersigned according to the USPTO assignment records or assignment documents attached to this form in accordance with 37 CFR 3.73(b).

Please change the correspondence address for the application identified in the attached statement under 37 CFR 3.73(b) to:

 The address associated with Customer Number: 

OR

<input type="checkbox"/> Firm or Individual Name			
Address			
City	State	Zip	
Country			
Telephone	Email		

Assignee Name and Address:

AWARE, INC.  
40 Middlesex Turnpike  
Bedford, MA 07130-1423**A copy of this form, together with a statement under 37 CFR 3.73(b) (Form PTO/SB/96 or equivalent) is required to be filed in each application in which this form is used. The statement under 37 CFR 3.73(b) may be completed by one of the practitioners appointed in this form if the appointed practitioner is authorized to act on behalf of the assignee, and must identify the application in which this Power of Attorney is to be filed.**

SIGNATURE of Assignee of Record

The individual whose signature and title is supplied below is authorized to act on behalf of the assignee

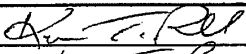
Signature		Date	1/8/09
Name	Kevin T. Russell	Telephone	781-657-5355
Title	VP, General Counsel		

This collection of information is required by 37 CFR 1.31, 1.32 and 1.33. The information is required to obtain or retain a benefit by the public which is to file (and by the USPTO to process) an application. Confidentiality is governed by 35 U.S.C. 122 and 37 CFR 1.11 and 1.14. This collection is estimated to take 3 minutes to complete, including gathering, preparing, and submitting the completed application form to the USPTO. Time will vary depending upon the individual case. Any comments on the amount of time you require to complete this form and/or suggestions for reducing this burden, should be sent to the Chief Information Officer, U.S. Patent and Trademark Office, U.S. Department of Commerce, P.O. Box 1450, Alexandria, VA 22313-1450. DO NOT SEND FEES OR COMPLETED FORMS TO THIS ADDRESS. SEND TO: Commissioner for Patents, P.O. Box 1450, Alexandria, VA 22313-1450.

If you need assistance in completing the form, call 1-800-PTO-9199 and select option 2.

## Electronic Acknowledgement Receipt

<b>EFS ID:</b>	12827810
<b>Application Number:</b>	13476310
<b>International Application Number:</b>	
<b>Confirmation Number:</b>	7896
<b>Title of Invention:</b>	Multicarrier Modulation Messaging for Power Level Per Subchannel Information
<b>First Named Inventor/Applicant Name:</b>	David M. Krinsky
<b>Customer Number:</b>	62574
<b>Filer:</b>	Jason Vick/Joanne Vos
<b>Filer Authorized By:</b>	Jason Vick
<b>Attorney Docket Number:</b>	5550-2-CON2-1-4
<b>Receipt Date:</b>	21-MAY-2012
<b>Filing Date:</b>	
<b>Time Stamp:</b>	17:02:52
<b>Application Type:</b>	Utility under 35 USC 111(a)

### Payment information:

Submitted with Payment	no
------------------------	----

### File Listing:

Document Number	Document Description	File Name	File Size(Bytes)/ Message Digest	Multi Part /.zip	Pages (if appl.)
1		Statement_Under_373b_w_PO A.pdf	254899 <small>a8f69425a890cc85bf98e477e9b2d7d7f6a15c6e</small>	yes	2

Multipart Description/PDF files in .zip description		
Document Description	Start	End
Assignee showing of ownership per 37 CFR 3.73(b).	1	1
Power of Attorney	2	2
<b>Warnings:</b>		
<b>Information:</b>		
<b>Total Files Size (in bytes):</b>		254899
<p>This Acknowledgement Receipt evidences receipt on the noted date by the USPTO of the indicated documents, characterized by the applicant, and including page counts, where applicable. It serves as evidence of receipt similar to a Post Card, as described in MPEP 503.</p> <p><b><u>New Applications Under 35 U.S.C. 111</u></b>  If a new application is being filed and the application includes the necessary components for a filing date (see 37 CFR 1.53(b)-(d) and MPEP 506), a Filing Receipt (37 CFR 1.54) will be issued in due course and the date shown on this Acknowledgement Receipt will establish the filing date of the application.</p> <p><b><u>National Stage of an International Application under 35 U.S.C. 371</u></b>  If a timely submission to enter the national stage of an international application is compliant with the conditions of 35 U.S.C. 371 and other applicable requirements a Form PCT/DO/EO/903 indicating acceptance of the application as a national stage submission under 35 U.S.C. 371 will be issued in addition to the Filing Receipt, in due course.</p> <p><b><u>New International Application Filed with the USPTO as a Receiving Office</u></b>  If a new international application is being filed and the international application includes the necessary components for an international filing date (see PCT Article 11 and MPEP 1810), a Notification of the International Application Number and of the International Filing Date (Form PCT/RO/105) will be issued in due course, subject to prescriptions concerning national security, and the date shown on this Acknowledgement Receipt will establish the international filing date of the application.</p>		

Under the Paperwork Reduction Act of 1995, no persons are required to respond to a collection of information unless it displays a valid OMB control number.

**STATEMENT UNDER 37 CFR 3.73(b)**Applicant/Patent Owner: AWARE, INC.Application No./Patent No.: 13/476,310Filed/Issue Date: May 21, 2012

Titled:

MULTICARRIER MODULATION MESSAGING FOR POWER LEVEL PER SUBCHANNEL INFORMATION

AWARE, INC.

, a Corporation

(Name of Assignee)

(Type of Assignee, e.g., corporation, partnership, university, government agency, etc.)

states that it is:

1.  the assignee of the entire right, title, and interest in;
2.  an assignee of less than the entire right, title, and interest in  
(The extent (by percentage) of its ownership interest is \_\_\_\_\_ %); or
3.  the assignee of an undivided interest in the entirety of (a complete assignment from one of the joint inventors was made)

the patent application/patent identified above, by virtue of either:

- A.  An assignment from the inventor(s) of the patent application/patent identified above. The assignment was recorded in the United States Patent and Trademark Office at Reel 012216, Frame 0842, or for which a copy therefore is attached.

**OR**

- B.  A chain of title from the inventor(s), of the patent application/patent identified above, to the current assignee as follows:

1. From: \_\_\_\_\_ To: \_\_\_\_\_

The document was recorded in the United States Patent and Trademark Office at  
Reel \_\_\_\_\_, Frame \_\_\_\_\_, or for which a copy thereof is attached.

2. From: \_\_\_\_\_ To: \_\_\_\_\_

The document was recorded in the United States Patent and Trademark Office at  
Reel \_\_\_\_\_, Frame \_\_\_\_\_, or for which a copy thereof is attached.

3. From: \_\_\_\_\_ To: \_\_\_\_\_

The document was recorded in the United States Patent and Trademark Office at  
Reel \_\_\_\_\_, Frame \_\_\_\_\_, or for which a copy thereof is attached.

- Additional documents in the chain of title are listed on a supplemental sheet(s).

- As required by 37 CFR 3.73(b)(1)(i), the documentary evidence of the chain of title from the original owner to the assignee was, or concurrently is being, submitted for recordation pursuant to 37 CFR 3.11.

[NOTE: A separate copy (i.e., a true copy of the original assignment document(s)) must be submitted to Assignment Division in accordance with 37 CFR Part 3, to record the assignment in the records of the USPTO. See MPEP 302.08]

The undersigned (whose title is supplied below) is authorized to act on behalf of the assignee.

Signature

Jason H. Vick

Printed or Typed Name

Date

21 May '12

Attorney for Assignee

Title

This collection of information is required by 37 CFR 3.73(b). The information is required to obtain or retain a benefit by the public which is to file (and by the USPTO to process) an application. Confidentiality is governed by 35 U.S.C. 122 and 37 CFR 1.11 and 1.14. This collection is estimated to take 12 minutes to complete, including gathering, preparing, and submitting the completed application form to the USPTO. Time will vary depending upon the individual case. Any comments on the amount of time you require to complete this form and/or suggestions for reducing this burden, should be sent to the Chief Information Officer, U.S. Patent and Trademark Office, U.S. Department of Commerce, P.O. Box 1450, Alexandria, VA 22313-1450. DO NOT SEND FEES OR COMPLETED FORMS TO THIS ADDRESS. SEND TO: Commissioner for Patents, P.O. Box 1450, Alexandria, VA 22313-1450.

If you need assistance in completing the form, call 1-800-PTO-9199 and select option 2.