

AO 120 (Rev. 08/10) Mail Stop 8 TO: Director of the U.S. Patent and Trademark Office P.O. Box 1450 Alexandria, VA 22313-1450	REPORT ON THE FILING OR DETERMINATION OF AN ACTION REGARDING A PATENT OR TRADEMARK
--	--

In Compliance with 35 U.S.C. § 290 and/or 15 U.S.C. § 1116 you are hereby advised that a court action has been filed in the U.S. District Court District of Delaware on the following
 Trademarks or Patents. (the patent action involves 35 U.S.C. § 292.):

DOCKET NO. 15-cv-616-RGA	DATE FILED 7/17/2015	U.S. DISTRICT COURT District of Delaware
PLAINTIFF TQ Delta, LLC		DEFENDANT Verizon Communications Inc., Verizon Services Corp., Verizon Online LLC, Verizon Business Network Services Inc., Verizon Delaware LLC, and Verizon Information Technologies LLC
PATENT OR TRADEMARK NO.	DATE OF PATENT OR TRADEMARK	HOLDER OF PATENT OR TRADEMARK
1 See Attached		
2		
3		
4		
5		

In the above—entitled case, the following patent(s)/ trademark(s) have been included:

DATE INCLUDED 9/9/2015	INCLUDED BY <input checked="" type="checkbox"/> Amendment <input type="checkbox"/> Answer <input type="checkbox"/> Cross Bill <input type="checkbox"/> Other Pleading	
PATENT OR TRADEMARK NO.	DATE OF PATENT OR TRADEMARK	HOLDER OF PATENT OR TRADEMARK
1 US 9,094,268 B2	7/28/2015	TQ Delta, LLC
2		
3		
4		
5		

In the above—entitled case, the following decision has been rendered or judgement issued:

DECISION/JUDGEMENT

CLERK	(BY) DEPUTY CLERK	DATE
-------	-------------------	------

Copy 1—Upon initiation of action, mail this copy to Director Copy 3—Upon termination of action, mail this copy to Director
 Copy 2—Upon filing document adding patent(s), mail this copy to Director Copy 4—Case file copy

	PATENT OR TRADEMARK NO.	DATE OF PATENT OR TRADEMARK	HOLDER OF PATENT OR TRADEMARK
1	US 6,961,369 B1	11/1/2005	TQ Delta, LLC
2	US 8,718,158 B2	5/6/2014	TQ Delta, LLC
3	US 9,014,243 B2	4/21/2015	TQ Delta, LLC
4	US 7,835,430 B2	11/16/2010	TQ Delta, LLC
5	US 8,238,412 B2	8/7/2012	TQ Delta, LLC
6	US 8,432,956 B2	4/30/2013	TQ Delta, LLC
7	US 8,611,404 B2	12/17/2013	TQ Delta, LLC

AO 120 (Rev. 08/10)

<p>TO: Mail Stop 8 Director of the U.S. Patent and Trademark Office P.O. Box 1450 Alexandria, VA 22313-1450</p>	<p>REPORT ON THE FILING OR DETERMINATION OF AN ACTION REGARDING A PATENT OR TRADEMARK</p>
--	---

In Compliance with 35 U.S.C. § 290 and/or 15 U.S.C. § 1116 you are hereby advised that a court action has been filed in the U.S. District Court District of Delaware on the following
 Trademarks or Patents. (the patent action involves 35 U.S.C. § 292.):

DOCKET NO. 15-cv-615-RGA	DATE FILED 7/17/2015	U.S. DISTRICT COURT District of Delaware
PLAINTIFF TQ Delta, LLC		DEFENDANT Time Warner Cable Inc. and Time Warner Cable Enterprises LLC
PATENT OR TRADEMARK NO.	DATE OF PATENT OR TRADEMARK	HOLDER OF PATENT OR TRADEMARK
1 See Attached		
2		
3		
4		
5		

In the above—entitled case, the following patent(s)/ trademark(s) have been included:

DATE INCLUDED 9/9/2015	INCLUDED BY <input checked="" type="checkbox"/> Amendment <input type="checkbox"/> Answer <input type="checkbox"/> Cross Bill <input type="checkbox"/> Other Pleading	
PATENT OR TRADEMARK NO.	DATE OF PATENT OR TRADEMARK	HOLDER OF PATENT OR TRADEMARK
1 US 9,094,268 B2	7/28/2015	TQ Delta, LLC
2		
3		
4		
5		

In the above—entitled case, the following decision has been rendered or judgement issued:

DECISION/JUDGEMENT

CLERK	(BY) DEPUTY CLERK	DATE
-------	-------------------	------

Copy 1—Upon initiation of action, mail this copy to Director Copy 3—Upon termination of action, mail this copy to Director
 Copy 2—Upon filing document adding patent(s), mail this copy to Director Copy 4—Case file copy

	PATENT OR TRADEMARK NO.	DATE OF PATENT OR TRADEMARK	HOLDER OF PATENT OR TRADEMARK
1	US 6,961,369 B1	11/1/2005	TQ Delta, LLC
2	US 8,718,158 B2	5/6/2014	TQ Delta, LLC
3	US 9,014,243 B2	4/21/2015	TQ Delta, LLC
4	US 7,835,430 B2	11/16/2010	TQ Delta, LLC
5	US 8,238,412 B2	8/7/2012	TQ Delta, LLC
6	US 8,432,956 B2	4/30/2013	TQ Delta, LLC
7	US 8,611,404 B2	12/17/2013	TQ Delta, LLC

AO 120 (Rev. 08/10)

<p>TO: Mail Stop 8 Director of the U.S. Patent and Trademark Office P.O. Box 1450 Alexandria, VA 22313-1450</p>	<p>REPORT ON THE FILING OR DETERMINATION OF AN ACTION REGARDING A PATENT OR TRADEMARK</p>
--	---

In Compliance with 35 U.S.C. § 290 and/or 15 U.S.C. § 1116 you are hereby advised that a court action has been filed in the U.S. District Court Middle District of Florida, Orlando Division on the following

Trademarks or Patents. (the patent action involves 35 U.S.C. § 292.):

DOCKET NO. 6:14-cv-1027	DATE FILED 6/26/2014	U.S. DISTRICT COURT Middle District of Florida, Orlando Division
PLAINTIFF Orlando Communications LLC		DEFENDANT LG Electronics, Inc., et al
PATENT OR TRADEMARK NO.	DATE OF PATENT OR TRADEMARK	HOLDER OF PATENT OR TRADEMARK
1 5,687,1296	11/11/1997	James Arthur Proctor, Jr., James Carl Otto
2 6,0009,553	12/28/0199	Dennis Martinez, Thomas Hengeveld, Michael Axford
3		
4		
5		

In the above—entitled case, the following patent(s)/ trademark(s) have been included:

DATE INCLUDED	INCLUDED BY <input type="checkbox"/> Amendment <input type="checkbox"/> Answer <input type="checkbox"/> Cross Bill <input type="checkbox"/> Other Pleading	
PATENT OR TRADEMARK NO.	DATE OF PATENT OR TRADEMARK	HOLDER OF PATENT OR TRADEMARK
1		
2		
3		
4		
5		

In the above—entitled case, the following decision has been rendered or judgement issued:

DECISION/JUDGEMENT Order of Dismissal
--

CLERK Sheryl Loesch	(BY) DEPUTY CLERK R. Olsen	DATE 9/9/2015
------------------------	-------------------------------	------------------

Copy 1—Upon initiation of action, mail this copy to Director Copy 3—Upon termination of action, mail this copy to Director
 Copy 2—Upon filing document adding patent(s), mail this copy to Director Copy 4—Case file copy

AO 120 (Rev. 08/10)

TO: Mail Stop 8 Director of the U.S. Patent and Trademark Office P.O. Box 1450 Alexandria, VA 22313-1450	REPORT ON THE FILING OR DETERMINATION OF AN ACTION REGARDING A PATENT OR TRADEMARK
---	--

In Compliance with 35 U.S.C. § 290 and/or 15 U.S.C. § 1116 you are hereby advised that a court action has been filed in the U.S. District Court Middle District of Florida, Orlando Division on the following
 Trademarks or Patents. (the patent action involves 35 U.S.C. § 292.):

DOCKET NO. 6:14-cv-1026	DATE FILED 6/26/2014	U.S. DISTRICT COURT Middle District of Florida, Orlando Division
PLAINTIFF Orlando Communications LLC		DEFENDANT LG Electronics, Inc., et al
PATENT OR TRADEMARK NO.	DATE OF PATENT OR TRADEMARK	HOLDER OF PATENT OR TRADEMARK
1 5,687,1296	11/11/1997	James Arthur Proctor, Jr., James Carl Otto
2 6,0009,553	12/28/0199	Dennis Martinez, Thomas Hengeveld, Michael Axford
3		
4		
5		

In the above—entitled case, the following patent(s)/ trademark(s) have been included:

DATE INCLUDED	INCLUDED BY <input type="checkbox"/> Amendment <input type="checkbox"/> Answer <input type="checkbox"/> Cross Bill <input type="checkbox"/> Other Pleading	
PATENT OR TRADEMARK NO.	DATE OF PATENT OR TRADEMARK	HOLDER OF PATENT OR TRADEMARK
1		
2		
3		
4		
5		

In the above—entitled case, the following decision has been rendered or judgement issued:

DECISION/JUDGEMENT Order of Dismissal
--

CLERK Sheryl Loesch	(BY) DEPUTY CLERK R. Olsen	DATE 9/9/2015
------------------------	-------------------------------	------------------

Copy 1—Upon initiation of action, mail this copy to Director Copy 3—Upon termination of action, mail this copy to Director
 Copy 2—Upon filing document adding patent(s), mail this copy to Director Copy 4—Case file copy

AO 120 (Rev. 08/10)

TO: Mail Stop 8 Director of the U.S. Patent and Trademark Office P.O. Box 1450 Alexandria, VA 22313-1450	REPORT ON THE FILING OR DETERMINATION OF AN ACTION REGARDING A PATENT OR TRADEMARK
---	--

In Compliance with 35 U.S.C. § 290 and/or 15 U.S.C. § 1116 you are hereby advised that a court action has been filed in the U.S. District Court Middle District of Florida, Orlando Division on the following
 Trademarks or Patents. (the patent action involves 35 U.S.C. § 292.):

DOCKET NO. 6:14-cv-1028	DATE FILED 6/26/2014	U.S. DISTRICT COURT Middle District of Florida, Orlando Division
PLAINTIFF Orlando Communications LLC		DEFENDANT HTC Corporation, et al
PATENT OR TRADEMARK NO.	DATE OF PATENT OR TRADEMARK	HOLDER OF PATENT OR TRADEMARK
1 5,687,1296	11/11/1997	James Arthur Proctor, Jr., James Carl Otto
2 6,0009,553	12/28/0199	Dennis Martinez, Thomas Hengeveld, Michael Axford
3		
4		
5		

In the above—entitled case, the following patent(s)/ trademark(s) have been included:

DATE INCLUDED	INCLUDED BY <input type="checkbox"/> Amendment <input type="checkbox"/> Answer <input type="checkbox"/> Cross Bill <input type="checkbox"/> Other Pleading	
PATENT OR TRADEMARK NO.	DATE OF PATENT OR TRADEMARK	HOLDER OF PATENT OR TRADEMARK
1		
2		
3		
4		
5		

In the above—entitled case, the following decision has been rendered or judgement issued:

DECISION/JUDGEMENT Order of Dismissal
--

CLERK Sheryl Loesch	(BY) DEPUTY CLERK R. Olsen	DATE 9/9/2015
------------------------	-------------------------------	------------------

Copy 1—Upon initiation of action, mail this copy to Director Copy 3—Upon termination of action, mail this copy to Director
 Copy 2—Upon filing document adding patent(s), mail this copy to Director Copy 4—Case file copy

AO 120 (Rev. 08/10)

TO: Mail Stop 8 Director of the U.S. Patent and Trademark Office P.O. Box 1450 Alexandria, VA 22313-1450	REPORT ON THE FILING OR DETERMINATION OF AN ACTION REGARDING A PATENT OR TRADEMARK
---	---

In Compliance with 35 U.S.C. § 290 and/or 15 U.S.C. § 1116 you are hereby advised that a court action has been filed in the U.S. District Court District of Delaware on the following
 Trademarks or Patents. (the patent action involves 35 U.S.C. § 292.);

DOCKET NO.	DATE FILED 7/17/2015	U.S. DISTRICT COURT District of Delaware
PLAINTIFF TQ Delta, LLC		DEFENDANT Verizon Communications Inc., Verizon Services Corp., Verizon Online LLC, Verizon Business Network Services Inc., Verizon Delaware LLC, and Verizon Information Technologies LLC
PATENT OR TRADEMARK NO.	DATE OF PATENT OR TRADEMARK	HOLDER OF PATENT OR TRADEMARK
1 See Attached		
2		
3		
4		
5		

In the above—entitled case, the following patent(s)/ trademark(s) have been included:

DATE INCLUDED	INCLUDED BY <input type="checkbox"/> Amendment <input type="checkbox"/> Answer <input type="checkbox"/> Cross Bill <input type="checkbox"/> Other Pleading	
PATENT OR TRADEMARK NO.	DATE OF PATENT OR TRADEMARK	HOLDER OF PATENT OR TRADEMARK
1		
2		
3		
4		
5		

In the above—entitled case, the following decision has been rendered or judgement issued:

DECISION/JUDGEMENT

CLERK	(BY) DEPUTY CLERK	DATE
-------	-------------------	------

Copy 1—Upon initiation of action, mail this copy to Director Copy 3—Upon termination of action, mail this copy to Director
 Copy 2—Upon filing document adding patent(s), mail this copy to Director Copy 4—Case file copy

	PATENT OR TRADEMARK NO.	DATE OF PATENT OR TRADEMARK	HOLDER OF PATENT OR TRADEMARK
1	US 6,961,369 B1	11/1/2005	TQ Delta, LLC
2	US 8,718,158 B2	5/6/2014	TQ Delta, LLC
3	US 9,014,243 B2	4/21/2015	TQ Delta, LLC
4	US 7,835,430 B2	11/16/2010	TQ Delta, LLC
5	US 8,238,412 B2	8/7/2012	TQ Delta, LLC
6	US 8,432,956 B2	4/30/2013	TQ Delta, LLC
7	US 8,611,404 B2	12/17/2013	TQ Delta, LLC

AO 120 (Rev. 08/10)

TO: Mail Stop 8 Director of the U.S. Patent and Trademark Office P.O. Box 1450 Alexandria, VA 22313-1450	REPORT ON THE FILING OR DETERMINATION OF AN ACTION REGARDING A PATENT OR TRADEMARK
---	--

In Compliance with 35 U.S.C. § 290 and/or 15 U.S.C. § 1116 you are hereby advised that a court action has been filed in the U.S. District Court Delaware on the following
 Trademarks or Patents. (the patent action involves 35 U.S.C. § 292.);

DOCKET NO.	DATE FILED	U.S. DISTRICT COURT
	9/4/2013	Delaware
PLAINTIFF		DEFENDANT
ROCHE PALO ALTO LLC and GENENTECH, INC.		WATSON LABORATORIES, INC. – FLORIDA
PATENT OR TRADEMARK NO.	DATE OF PATENT OR TRADEMARK	HOLDER OF PATENT OR TRADEMARK
1 6,083,953	7/4/2000	Roche Palo Alto LLC
2		
3		
4		
5		

In the above—entitled case, the following patent(s)/ trademark(s) have been included:

DATE INCLUDED	INCLUDED BY
	<input type="checkbox"/> Amendment <input type="checkbox"/> Answer <input type="checkbox"/> Cross Bill <input type="checkbox"/> Other Pleading
PATENT OR TRADEMARK NO.	DATE OF PATENT OR TRADEMARK
1	
2	
3	
4	
5	

In the above—entitled case, the following decision has been rendered or judgement issued:

DECISION/JUDGEMENT <i>Dismissed - See Attached</i>

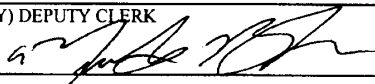
CLERK John A Cerino, Clerk United States District Court 844 N. King Street, Unit 18 Wilmington, DE 19801	(BY) DEPUTY CLERK 	DATE 7/17/15
--	---	-----------------

Copy 1—Upon initiation of action, mail this copy to Director / Copy 3—Upon termination of action, mail this copy to Director
 Copy 2—Upon filing document adding patent(s), mail this copy to Director Copy 4—Case file copy

AO 120 (Rev. 3/04)

TO: Mail Stop 8 Director of the U.S. Patent and Trademark Office P.O. Box 1450 Alexandria, VA 22313-1450	REPORT ON THE FILING OR DETERMINATION OF AN ACTION REGARDING A PATENT OR TRADEMARK
---	--

In Compliance with 35 U.S.C. § 290 and/or 15 U.S.C. § 1116 you are hereby advised that a court action has been filed in the U.S. District Court Massachusetts on the following Patents or Trademarks:

DOCKET NO.	DATE FILED 7/17/2015	U.S. DISTRICT COURT Massachusetts
PLAINTIFF BOSTON PROPERTIES LIMITED PARTNERSHIP		DEFENDANT CLAUDETTE MOUSSA, d/b/a Boston Properties Advisors
PATENT OR TRADEMARK NO.	DATE OF PATENT OR TRADEMARK	HOLDER OF PATENT OR TRADEMARK
1 2,527,181	1/8/2002	BOSTON PROPERTIES LIMITED PARTNERSHIP
2		
3		
4		
5		

In the above—entitled case, the following patent(s)/ trademark(s) have been included:

DATE INCLUDED	INCLUDED BY <input checked="" type="checkbox"/> Amendment <input checked="" type="checkbox"/> Answer <input checked="" type="checkbox"/> Cross Bill <input checked="" type="checkbox"/> Other Pleading		
PATENT OR TRADEMARK NO.	DATE OF PATENT OR TRADEMARK	HOLDER OF PATENT OR TRADEMARK	
1			
2			
3			
4			
5			

In the above—entitled case, the following decision has been rendered or judgement issued:

DECISION/JUDGEMENT

CLERK	(BY) DEPUTY CLERK	DATE
-------	-------------------	------

Copy 1—Upon initiation of action, mail this copy to Director Copy 3—Upon termination of action, mail this copy to Director
 Copy 2—Upon filing document adding patent(s), mail this copy to Director Copy 4—Case file copy

AO 120 (Rev. 08/10)

TO: Mail Stop 8 Director of the U.S. Patent and Trademark Office P.O. Box 1450 Alexandria, VA 22313-1450	REPORT ON THE FILING OR DETERMINATION OF AN ACTION REGARDING A PATENT OR TRADEMARK
---	---

In Compliance with 35 U.S.C. § 290 and/or 15 U.S.C. § 1116 you are hereby advised that a court action has been filed in the U.S. District Court Transferred to Delaware from Alabama on the following
 Trademarks or Patents. (the patent action involves 35 U.S.C. § 292.):

DOCKET NO. 15-cv-121-RGA	DATE FILED 7/17/2014	U.S. DISTRICT COURT Transferred to Delaware from Alabama
PLAINTIFF ADTRAN, Inc.		DEFENDANT TQ Delta, LLC
PATENT OR TRADEMARK NO.	DATE OF PATENT OR TRADEMARK	HOLDER OF PATENT OR TRADEMARK
1 See Attachment #1		
2		
3		
4		
5		

In the above—entitled case, the following patent(s)/ trademark(s) have been included:

DATE INCLUDED 3/13/2015	INCLUDED BY <input type="checkbox"/> Amendment <input checked="" type="checkbox"/> Answer <input type="checkbox"/> Cross Bill <input type="checkbox"/> Other Pleading	
PATENT OR TRADEMARK NO.	DATE OF PATENT OR TRADEMARK	HOLDER OF PATENT OR TRADEMARK
1 See Attachment #2		
2		
3		
4		
5		

In the above—entitled case, the following decision has been rendered or judgement issued:

DECISION/JUDGEMENT

CLERK	(BY) DEPUTY CLERK	DATE
-------	-------------------	------

Copy 1—Upon initiation of action, mail this copy to Director Copy 3—Upon termination of action, mail this copy to Director
 Copy 2—Upon filing document adding patent(s), mail this copy to Director Copy 4—Case file copy

Patent or Trademark No.	Date of Patent or Trademark	Holder of Patent or Trademark
1. U.S. 7,453,881 B2	11/18/2008	TQ Delta, LLC
2. U.S. 7,809,028 B2	10/05/2010	TQ Delta, LLC
3. U.S. 7,978,706 B2	7/12/2011	TQ Delta, LLC
4. U.S. 8,422,511 B2	4/16/2013	TQ Delta, LLC
5. U.S. 6,445,730 B1	9/03/2002	TQ Delta, LLC
6. U.S. 7,292,627 B2	11/6/2007	TQ Delta, LLC
7. U.S. 7,451,379 B2	11/11/2008	TQ Delta, LLC
8. U.S. 7,471,721 B2	12/30/2008	TQ Delta, LLC
9. U.S. 7,570,686 B2	8/4/2009	TQ Delta, LLC
10. U.S. 7,831,890 B2	11/09/2010	TQ Delta, LLC
11. U.S. 7,835,430 B2	11/16/2010	TQ Delta, LLC
12. U.S. 7,836,381 B1	11/16/2010	TQ Delta, LLC
13. U.S. 7,844,882 B2	11/30/2010	TQ Delta, LLC
14. U.S. 7,889,784 B2	2/15/2011	TQ Delta, LLC
15. U.S. 7,925,958 B2	04/12/2011	TQ Delta, LLC
16. U.S. 7,978,753 B2	07/12/2011	TQ Delta, LLC
17. U.S. 7,979,778 B2	07/12/2011	TQ Delta, LLC
18. U.S. 8,073,041 B1	12/6/2011	TQ Delta, LLC
19. U.S. 8,090,008 B2	1/3/2012	TQ Delta, LLC
20. U.S. 8,218,610 B2	7/10/2012	TQ Delta, LLC
21. U.S. 8,238,412 B2	08/07/2012	TQ Delta, LLC
22. U.S. 8,276,048 B2	09/25/2012	TQ Delta, LLC
23. U.S. 8,355,427 B2	1/15/2013	TQ Delta, LLC

24. U.S. 8,432,956 B2	4/30/2013	TQ Delta, LLC
25. U.S. 8,437,382 B2	5/7/2013	TQ Delta, LLC
26. U.S. 8,462,835 B2	6/11/2013	TQ Delta, LLC
27. U.S. 8,495,473 B2	7/23/2013	TQ Delta, LLC
28. U.S. 8,516,337 B2	08/20/2013	TQ Delta, LLC

	PATENT OR TRADEMARK NO.	DATE OF PATENT OR TRADEMARK	HOLDER OF PATENT OR TRADEMARK
1	US 7,796,705 B2	9/14/2010	TQ Delta, LLC
2	US 8,335,956 B2	12/18/2012	TQ Delta, LLC
3	US 8,407,546 B2	3/26/2013	TQ Delta, LLC
4	US 8,468,411 B2	6/18/2013	TQ Delta, LLC
5	US 8,645,784 B2	2/4/2014	TQ Delta, LLC
6	US 8,595,577 B2	11/26/2013	TQ Delta, LLC

AO 120 (Rev. 08/10)

TO: Mail Stop 8 Director of the U.S. Patent and Trademark Office P.O. Box 1450 Alexandria, VA 22313-1450	REPORT ON THE FILING OR DETERMINATION OF AN ACTION REGARDING A PATENT OR TRADEMARK
---	--

In Compliance with 35 U.S.C. § 290 and/or 15 U.S.C. § 1116 you are hereby advised that a court action has been filed in the U.S. District Court District of Delaware on the following
 Trademarks or Patents. (the patent action involves 35 U.S.C. § 292.):

DOCKET NO.	DATE FILED 7/18/2014	U.S. DISTRICT COURT District of Delaware
PLAINTIFF TQ Delta, LLC		DEFENDANT ADTRAN, Inc.
PATENT OR TRADEMARK NO.	DATE OF PATENT OR TRADEMARK	HOLDER OF PATENT OR TRADEMARK
1	See Attached	
2	32 Pat's	
3		
4		
5		

In the above—entitled case, the following patent(s)/ trademark(s) have been included:

DATE INCLUDED	INCLUDED BY	<input type="checkbox"/> Amendment <input type="checkbox"/> Answer <input type="checkbox"/> Cross Bill <input type="checkbox"/> Other Pleading
PATENT OR TRADEMARK NO.	DATE OF PATENT OR TRADEMARK	HOLDER OF PATENT OR TRADEMARK
1		
2		
3		
4		
5		

In the above—entitled case, the following decision has been rendered or judgement issued:

DECISION/JUDGEMENT

CLERK	(BY) DEPUTY CLERK	DATE
-------	-------------------	------

Copy 1—Upon initiation of action, mail this copy to Director Copy 3—Upon termination of action, mail this copy to Director
 Copy 2—Upon filing document adding patent(s), mail this copy to Director Copy 4—Case file copy

	PATENT OR TRADEMARK NO.	DATE OF PATENT OR TRADEMARK	HOLDER OF PATENT OR TRADEMARK
1	US 8,090,008 B2	1/3/2012	TQ Delta, LLC
2	US 8,073,041 B1	12/6/2011	TQ Delta, LLC
3	US 7,292,627 B2	11/6/2007	TQ Delta, LLC
4	US 7,471,721 B2	12/30/2008	TQ Delta, LLC
5	US 8,218,610 B2	7/10/2012	TQ Delta, LLC
6	US 8,355,427 B2	1/15/2013	TQ Delta, LLC
7	US 7,453,881 B2	11/18/2008	TQ Delta, LLC
8	US 7,809,028 B2	10/5/2010	TQ Delta, LLC
9	US 7,978,706 B2	7/12/2011	TQ Delta, LLC
10	US 8,422,511 B2	4/16/2013	TQ Delta, LLC
11	US 7,889,784 B2	2/15/2011	TQ Delta, LLC
12	US 7,835,430 B2	11/16/2010	TQ Delta, LLC
13	US 7,570,686 B2	8/4/2009	TQ Delta, LLC
14	US 8,238,412 B2	8/7/2012	TQ Delta, LLC
15	US 8,432,956 B2	4/30/2013	TQ Delta, LLC
16	US 7,451,379 B2	11/11/2008	TQ Delta, LLC
17	US 8,516,337 B2	8/20/2013	TQ Delta, LLC
18	US 7,979,778 B2	7/12/2011	TQ Delta, LLC
19	US 7,925,958 B2	4/12/2011	TQ Delta, LLC
20	US 8,462,835 B2	6/11/2013	TQ Delta, LLC
21	US 8,594,162 B2	11/26/2013	TQ Delta, LLC
22	US 7,978,753 B2	7/12/2011	TQ Delta, LLC
23	US 6,445,730 B1	9/3/2002	TQ Delta, LLC
24	US 8,611,404 B2	12/17/2013	TQ Delta, LLC
25	US 8,437,382 B2	5/7/2013	TQ Delta, LLC
26	US 7,836,381 B1	11/16/2010	TQ Delta, LLC
27	US 7,844,882 B2	11/30/2010	TQ Delta, LLC
28	US 8,276,048 B2	9/25/2012	TQ Delta, LLC
29	US 8,495,473 B2	7/23/2013	TQ Delta, LLC
30	US 8,607,126 B1	12/10/2013	TQ Delta, LLC
31	US 7,831,890 B2	11/9/2010	TQ Delta, LLC
32	US 8,625,660 B2	1/7/2014	TQ Delta, LLC

Birch, Melvin (Akima)

From: ded_nefreply@ded.uscourts.gov
Sent: Wednesday, November 20, 2013 4:56 PM
To: ded_ecf@ded.uscourts.gov
Subject: Activity in Case 1:13-cv-01835-RGA TQ Delta LLC v. Pace Americas Inc.
Patent/Trademark Report to Commissioner

This is an automatic e-mail message generated by the CM/ECF system. Please **DO NOT RESPOND** to this e-mail because the mail box is unattended.

*****NOTE TO PUBLIC ACCESS USERS***** Judicial Conference of the United States policy permits attorneys of record and parties in a case (including pro se litigants) to receive one free electronic copy of all documents filed electronically, if receipt is required by law or directed by the filer. PACER access fees apply to all other users. To avoid later charges, download a copy of each document during this first viewing. However, if the referenced document is a transcript, the free copy and 30 page limit do not apply.

U.S. District Court

District of Delaware

Notice of Electronic Filing

The following transaction was entered by Farnan, Brian on 11/20/2013 at 4:56 PM EST and filed on 11/20/2013

Case Name: TQ Delta LLC v. Pace Americas Inc.

Case Number: 1:13-cv-01835-RGA

Filer:

Document Number: 7

Docket Text:

Report to the Commissioner of Patents and Trademarks for Patent/Trademark Number(s) US 8,090,008 B2; US 8,073,041 B1; US 7,292,627 B2; US 7,471,721 B2; US 8,218,610 B2; US 8,355,427 B2; US 7,453,881 B2; US 7,978,706 B2; US 8,422,511 B2; US 7,889,784 B2; US 7,835,430 B2; US 7,570,686 B2; US 8,238,412 B2; US 8,432,956 B2; US 7,451,379 B2; US 8,516,337 B2; US 7,979,778 B2; US 7,925,958 B2; US 8,462,835 B2; US 7,836,381 B1; US 7,844,882 B2; US 8,276,048 B2; US 8,495,473 B2; US 7,831,890 B2; . (Farnan, Brian)

1:13-cv-01835-RGA Notice has been electronically mailed to:

Brian E. Farnan bfarnan@farnanlaw.com, tfarnan@farnanlaw.com

Michael J. Farnan mfarnan@farnanlaw.com, tfarnan@farnanlaw.com

1:13-cv-01835-RGA Filer will deliver document by other means to:

The following document(s) are associated with this transaction:

From: ded_nefreply@ded.uscourts.gov
Sent: Wednesday, November 20, 2013 5:07 PM
To: ded_ecf@ded.uscourts.gov
Subject: Activity in Case 1:13-cv-01836-RGA TQ Delta LLC v. Zhone Technologies Inc.
Patent/Trademark Report to Commissioner

This is an automatic e-mail message generated by the CM/ECF system. Please **DO NOT RESPOND** to this e-mail because the mail box is unattended.

*****NOTE TO PUBLIC ACCESS USERS***** Judicial Conference of the United States policy permits attorneys of record and parties in a case (including pro se litigants) to receive one free electronic copy of all documents filed electronically, if receipt is required by law or directed by the filer. PACER access fees apply to all other users. To avoid later charges, download a copy of each document during this first viewing. However, if the referenced document is a transcript, the free copy and 30 page limit do not apply.

U.S. District Court

District of Delaware

Notice of Electronic Filing

The following transaction was entered by Farnan, Brian on 11/20/2013 at 5:07 PM EST and filed on 11/20/2013

Case Name: TQ Delta LLC v. Zhone Technologies Inc.

Case Number: 1:13-cv-01836-RGA

Filer:

Document Number: 7

Docket Text:

Report to the Commissioner of Patents and Trademarks for Patent/Trademark Number(s) US 8,090,008 B2; US 8,073,041 B1; US 7,292,627 B2; US 7,471,721 B2; US 8,218,610 B2; US 8,355,427 B2; US 7,453,881 B2; US 7,809,028 B2; US 7,978,706 B2; US 8,422,511 B2; US 7,796,705 B2; US 7,889,784 B2; US 7,835,430 B2; US 7,570,686 B2; US 8,238,412 B2; US 8,432,956 B2; US 7,451,379 B2; US 8,516,337 B2; US 7,979,778 B2; US 7,925,958 B2; US 8,462,835 B2; US 7,978,753 B2; US 6,445,730 B1; US 8,437,382 B2; US 7,836,381 B1; US 7,844,882 B2; US 8,276,048 B2; US 8,495,473 B2; US 7,831,890 B2; US 8,335,956 B2; US 8,468,411 B2; US 8,407,546 B2 . (Farnan, Brian)

1:13-cv-01836-RGA Notice has been electronically mailed to:

Brian E. Farnan bfarnan@farnanlaw.com, tfarnan@farnanlaw.com

Michael J. Farnan mfarnan@farnanlaw.com, tfarnan@farnanlaw.com

1:13-cv-01836-RGA Filer will deliver document by other means to:

AO 120 (Rev. 08/10)

TO: Mail Stop 8 Director of the U.S. Patent and Trademark Office P.O. Box 1450 Alexandria, VA 22313-1450	REPORT ON THE FILING OR DETERMINATION OF AN ACTION REGARDING A PATENT OR TRADEMARK
---	--

In Compliance with 35 U.S.C. § 290 and/or 15 U.S.C. § 1116 you are hereby advised that a court action has been filed in the U.S. District Court District of Delaware on the following

Trademarks or Patents. (the patent action involves 35 U.S.C. § 292.):

DOCKET NO.	DATE FILED 12/9/2013	U.S. DISTRICT COURT District of Delaware
PLAINTIFF TQ Delta, LLC		DEFENDANT ZyXEL Communications Corporation and ZyXEL Communications, Inc.
PATENT OR TRADEMARK NO.	DATE OF PATENT OR TRADEMARK	HOLDER OF PATENT OR TRADEMARK
1	See Attached	
2		
3		
4		
5		

In the above—entitled case, the following patent(s)/ trademark(s) have been included:

DATE INCLUDED	INCLUDED BY <input type="checkbox"/> Amendment <input type="checkbox"/> Answer <input type="checkbox"/> Cross Bill <input type="checkbox"/> Other Pleading	
PATENT OR TRADEMARK NO.	DATE OF PATENT OR TRADEMARK	HOLDER OF PATENT OR TRADEMARK
1		
2		
3		
4		
5		

In the above—entitled case, the following decision has been rendered or judgement issued:

DECISION/JUDGEMENT

CLERK	(BY) DEPUTY CLERK	DATE
-------	-------------------	------

Copy 1—Upon initiation of action, mail this copy to Director Copy 3—Upon termination of action, mail this copy to Director
 Copy 2—Upon filing document adding patent(s), mail this copy to Director Copy 4—Case file copy

	PATENT OR TRADEMARK NO.	DATE OF PATENT OR TRADEMARK	HOLDER OF PATENT OR TRADEMARK
1	US 8,090,008 B2	1/3/2012	TQ Delta, LLC
2	US 8,073,041 B1	12/6/2011	TQ Delta, LLC
3	US 7,292,627 B2	11/6/2007	TQ Delta, LLC
4	US 7,471,721 B2	12/30/2008	TQ Delta, LLC
5	US 8,218,610 B2	7/10/2012	TQ Delta, LLC
6.	US 8,355,427 B2	1/15/2013	TQ Delta, LLC
7	US 7,453,881 B2	11/18/2008	TQ Delta, LLC
8	US 7,809,028 B2	10/5/2010	TQ Delta, LLC
9	US 7,978,706 B2	7/12/2011	TQ Delta, LLC
10	US 8,422,511 B2	4/16/2013	TQ Delta, LLC
11	US 7,796,705 B2	9/14/2010	TQ Delta, LLC
12	US 7,889,784 B2	2/15/2011	TQ Delta, LLC
13	US 7,835,430 B2	11/16/2010	TQ Delta, LLC
14	US 7,570,686 B2	8/4/2009	TQ Delta, LLC
15	US 8,238,412 B2	8/7/2012	TQ Delta, LLC
16	US 8,432,956 B2	4/30/2013	TQ Delta, LLC
17	US 7,451,379 B2	11/11/2008	TQ Delta, LLC
18	US 8,516,337 B2	8/20/2013	TQ Delta, LLC
19	US 7,979,778 B2	7/12/2011	TQ Delta, LLC
20	US 7,925,958 B2	4/12/2011	TQ Delta, LLC
21	US 8,462,835 B2	6/11/2013	TQ Delta, LLC
22	US 7,978,753 B2	7/12/2011	TQ Delta, LLC
23	US 6,445,730 B1	9/3/2002	TQ Delta, LLC
24	US 8,437,382 B2	5/7/2013	TQ Delta, LLC
25	US 7,836,381 B1	11/16/2010	TQ Delta, LLC
26	US 7,844,882 B2	11/30/2010	TQ Delta, LLC
27	US 8,276,048 B2	9/25/2012	TQ Delta, LLC
28	US 8,495,473 B2	7/23/2013	TQ Delta, LLC
29	US 7,831,890 B2	11/9/2010	TQ Delta, LLC
30	US 8,335,956 B2	12/18/2012	TQ Delta, LLC
31	US 8,468,411 B2	6/18/2013	TQ Delta, LLC
32	US 8,407,546 B2	3/26/2013	TQ Delta, LLC

TO: Mail Stop 8 Director of the U.S. Patent and Trademark Office P.O. Box 1450 Alexandria, VA 22313-1450	REPORT ON THE FILING OR DETERMINATION OF AN ACTION REGARDING A PATENT OR TRADEMARK
---	---

In Compliance with 35 U.S.C. § 290 and/or 15 U.S.C. § 1116 you are hereby advised that a court action has been filed in the U.S. District Court Northern District of Texas, Dallas Division on the following

Trademarks or Patents. (the patent action involves 35 U.S.C. § 292.):

DOCKET NO. 3:12-cv-1462-L	DATE FILED 5/10/2012	U.S. DISTRICT COURT Northern District of Texas, Dallas Division
PLAINTIFF Boulle Ltd		DEFENDANT De Boulle Diamond & Jewelry Inc
PATENT OR TRADEMARK NO.	DATE OF PATENT OR TRADEMARK	HOLDER OF PATENT OR TRADEMARK
1 4,086,050	1/17/2012	Boulle Ltd
2		
3		
4		
5		

In the above—entitled case, the following patent(s)/ trademark(s) have been included:

DATE INCLUDED 12/9/2013	INCLUDED BY <input checked="" type="checkbox"/> Amendment <input type="checkbox"/> Answer <input type="checkbox"/> Cross Bill <input type="checkbox"/> Other Pleading		
PATENT OR TRADEMARK NO.	DATE OF PATENT OR TRADEMARK	HOLDER OF PATENT OR TRADEMARK	
1 3,078,625	4/11/2006	De Boulle Diamond & Jewelry Inc	
2 3,078,627	4/11/2006	De Boulle Diamond & Jewelry Inc	
3			
4			
5			

In the above—entitled case, the following decision has been rendered or judgement issued:

DECISION/JUDGEMENT

CLERK Karen Mitchell	(BY) DEPUTY CLERK s/A. Lowe-Monserrate	DATE 12/10/2013
-------------------------	---	--------------------

Copy 1—Upon initiation of action, mail this copy to Director Copy 3—Upon termination of action, mail this copy to Director
 Copy 2—Upon filing document adding patent(s), mail this copy to Director Copy 4—Case file copy

AO 120 (Rev. 08/10)

TO: Mail Stop 8 Director of the U.S. Patent and Trademark Office P.O. Box 1450 Alexandria, VA 22313-1450	REPORT ON THE FILING OR DETERMINATION OF AN ACTION REGARDING A PATENT OR TRADEMARK
---	---

In Compliance with 35 U.S.C. § 290 and/or 15 U.S.C. § 1116 you are hereby advised that a court action has been filed in the U.S. District Court District of Delaware on the following
 Trademarks or Patents. (the patent action involves 35 U.S.C. § 292.);

DOCKET NO.	DATE FILED 11/4/2013	U.S. DISTRICT COURT District of Delaware
PLAINTIFF TQ Delta, LLC		DEFENDANT Pace Americas, Inc.
PATENT OR TRADEMARK NO.	DATE OF PATENT OR TRADEMARK	HOLDER OF PATENT OR TRADEMARK
1	See Attached	
2		
3		
4		
5		

In the above—entitled case, the following patent(s)/ trademark(s) have been included:

DATE INCLUDED	INCLUDED BY <input type="checkbox"/> Amendment <input type="checkbox"/> Answer <input type="checkbox"/> Cross Bill <input type="checkbox"/> Other Pleading		
PATENT OR TRADEMARK NO.	DATE OF PATENT OR TRADEMARK	HOLDER OF PATENT OR TRADEMARK	
1			
2			
3			
4			
5			

In the above—entitled case, the following decision has been rendered or judgement issued:

DECISION/JUDGEMENT

CLERK	(BY) DEPUTY CLERK	DATE
-------	-------------------	------

Copy 1—Upon initiation of action, mail this copy to Director Copy 3—Upon termination of action, mail this copy to Director
 Copy 2—Upon filing document adding patent(s), mail this copy to Director Copy 4—Case file copy

	PATENT OR TRADEMARK NO.	DATE OF PATENT OR TRADEMARK	HOLDER OF PATENT OR TRADEMARK
1	US 8,090,008 B2	1/3/2012	TQ Delta, LLC
2	US 8,073,041 B1	12/6/2011	TQ Delta, LLC
3	US 7,292,627 B2	11/6/2007	TQ Delta, LLC
4	US 7,471,721 B2	12/30/2008	TQ Delta, LLC
5	US 8,218,610 B2	7/10/2012	TQ Delta, LLC
6	US 8,355,427 B2	1/15/2013	TQ Delta, LLC
7	US 7,453,881 B2	11/18/2008	TQ Delta, LLC
8	US 7,978,706 B2	7/12/2011	TQ Delta, LLC
9	US 8,422,511 B2	4/16/2013	TQ Delta, LLC
10	US 7,889,784 B2	2/15/2011	TQ Delta, LLC
11	US 7,835,430 B2	11/16/2010	TQ Delta, LLC
12	US 7,570,686 B2	8/4/2009	TQ Delta, LLC
13	US 8,238,412 B2	8/7/2012	TQ Delta, LLC
14	US 8,432,956 B2	4/30/2013	TQ Delta, LLC
15	US 7,451,379 B2	11/11/2008	TQ Delta, LLC
16	US 8,516,337 B2	8/20/2013	TQ Delta, LLC
17	US 7,979,778 B2	7/12/2011	TQ Delta, LLC
18	US 7,925,958 B2	4/12/2011	TQ Delta, LLC
19	US 8,462,835 B2	6/11/2013	TQ Delta, LLC

AO 120 (Rev. 08-10)

TO: Mail Stop 8 Director of the U.S. Patent and Trademark Office P.O. Box 1450 Alexandria, VA 22313-1450	REPORT ON THE FILING OR DETERMINATION OF AN ACTION REGARDING A PATENT OR TRADEMARK
---	---

In Compliance with 35 U.S.C. § 290 and/or 15 U.S.C. § 1116 you are hereby advised that a court action has been filed in the U.S. District Court District of Delaware on the following
 Trademarks or Patents. (the patent action involves 35 U.S.C. § 292.):

DOCKET NO.	DATE FILED 11/4/2013	U.S. DISTRICT COURT District of Delaware
PLAINTIFF TQ Delta, LLC		DEFENDANT Zhone Technologies, Inc.
PATENT OR TRADEMARK NO.	DATE OF PATENT OR TRADEMARK	HOLDER OF PATENT OR TRADEMARK
1	See Attached	
2		
3		
4		
5		

In the above--entitled case, the following patent(s)/ trademark(s) have been included:

DATE INCLUDED	INCLUDED BY <input type="checkbox"/> Amendment <input type="checkbox"/> Answer <input type="checkbox"/> Cross Bill <input type="checkbox"/> Other Pleading	
PATENT OR TRADEMARK NO.	DATE OF PATENT OR TRADEMARK	HOLDER OF PATENT OR TRADEMARK
1		
2		
3		
4		
5		

In the above--entitled case, the following decision has been rendered or judgement issued:

DECISION/JUDGEMENT

CLERK	(BY) DEPUTY CLERK	DATE
-------	-------------------	------

Copy 1—Upon initiation of action, mail this copy to Director Copy 3—Upon termination of action, mail this copy to Director
 Copy 2—Upon filing document adding patent(s), mail this copy to Director Copy 4—Case file copy

	PATENT OR TRADEMARK NO.	DATE OF PATENT OR TRADEMARK	HOLDER OF PATENT OR TRADEMARK
1	US 8,090,008 B2	1/3/2012	TQ Delta, LLC
2	US 8,073,041 B1	12/6/2011	TQ Delta, LLC
3	US 7,292,627 B2	11/6/2007	TQ Delta, LLC
4	US 7,471,721 B2	12/30/2008	TQ Delta, LLC
5	US 8,218,610 B2	7/10/2012	TQ Delta, LLC
6	US 8,355,427 B2	1/15/2013	TQ Delta, LLC
7	US 7,453,881 B2	11/18/2008	TQ Delta, LLC
8	US 7,809,028 B2	10/5/2010	TQ Delta, LLC
9	US 7,978,706 B2	7/12/2011	TQ Delta, LLC
10	US 8,422,511 B2	4/16/2013	TQ Delta, LLC
11	US 7,796,705 B2	9/14/2010	TQ Delta, LLC
12	US 7,889,784 B2	2/15/2011	TQ Delta, LLC
13	US 7,835,430 B2	11/16/2010	TQ Delta, LLC
14	US 7,570,686 B2	8/4/2009	TQ Delta, LLC
15	US 8,238,412 B2	8/7/2012	TQ Delta, LLC
16	US 8,432,956 B2	4/30/2013	TQ Delta, LLC
17	US 7,451,379 B2	11/11/2008	TQ Delta, LLC
18	US 8,516,337 B2	8/20/2013	TQ Delta, LLC
19	US 7,979,778 B2	7/12/2011	TQ Delta, LLC
20	US 7,925,958 B2	4/12/2011	TQ Delta, LLC
21	US 8,462,835 B2	6/11/2013	TQ Delta, LLC
22	US 7,978,753 B2	7/12/2011	TQ Delta, LLC
23	US 6,445,730 B1	9/3/2002	TQ Delta, LLC
24	US 8,437,382 B2	5/7/2013	TQ Delta, LLC



UNITED STATES PATENT AND TRADEMARK OFFICE

UNITED STATES DEPARTMENT OF COMMERCE
United States Patent and Trademark Office
Address: COMMISSIONER FOR PATENTS
PO Box 1450
Alexandria, Virginia 22313-1450
www.uspto.gov

Table with 7 columns: APPLICATION NUMBER, FILING or 371(c) DATE, GRP ART UNIT, FIL FEE REC'D, ATTY. DOCKET NO, TOT CLAIMS, IND CLAIMS. Row 1: 13/476,310, 05/21/2012, 2631, 2050, 6936-2-CON-2-1-4, 9, 5

CONFIRMATION NO. 7896

CORRECTED FILING RECEIPT



62574
Jason H. Vick
Sheridan Ross, PC
Suite # 1200
1560 Broadway
Denver, CO 80202

Date Mailed: 06/24/2013

Receipt is acknowledged of this non-provisional patent application. The application will be taken up for examination in due course. Applicant will be notified as to the results of the examination. Any correspondence concerning the application must include the following identification information: the U.S. APPLICATION NUMBER, FILING DATE, NAME OF APPLICANT, and TITLE OF INVENTION. Fees transmitted by check or draft are subject to collection. Please verify the accuracy of the data presented on this receipt. If an error is noted on this Filing Receipt, please submit a written request for a Filing Receipt Correction. Please provide a copy of this Filing Receipt with the changes noted thereon. If you received a "Notice to File Missing Parts" for this application, please submit any corrections to this Filing Receipt with your reply to the Notice. When the USPTO processes the reply to the Notice, the USPTO will generate another Filing Receipt incorporating the requested corrections

Inventor(s)

David M. Krinsky, Acton, MA;
Robert Edmund Pizzano JR., Stoneham, MA;

Applicant(s)

David M. Krinsky, Acton, MA;
Robert Edmund Pizzano JR., Stoneham, MA;

Assignment For Published Patent Application

AWARE, INC., Bedford, MA

Power of Attorney: The patent practitioners associated with Customer Number 62574

Domestic Priority data as claimed by applicant

This application is a CON of 12/779,660 05/13/2010 PAT 8238412
which is a CON of 12/477,742 06/03/2009 PAT 7835430
which is a CON of 10/619,691 07/16/2003 PAT 7570686
which is a CON of 09/755,173 01/08/2001 PAT 6658052
which claims benefit of 60/224,308 08/10/2000
and claims benefit of 60/174,865 01/07/2000

Foreign Applications for which priority is claimed (You may be eligible to benefit from the Patent Prosecution Highway program at the USPTO. Please see http://www.uspto.gov for more information.) - None.

Foreign application information must be provided in an Application Data Sheet in order to constitute a claim to foreign priority. See 37 CFR 1.55 and 1.76.

If Required, Foreign Filing License Granted: 05/31/2012

The country code and number of your priority application, to be used for filing abroad under the Paris Convention, is **US 13/476,310**

Projected Publication Date: Not Applicable

Non-Publication Request: No

Early Publication Request: No
Title

Multicarrier Modulation Messaging for Power Level Per Subchannel Information

Preliminary Class

375

Statement under 37 CFR 1.55 or 1.78 for AIA (First Inventor to File) Transition Applications: No

PROTECTING YOUR INVENTION OUTSIDE THE UNITED STATES

Since the rights granted by a U.S. patent extend only throughout the territory of the United States and have no effect in a foreign country, an inventor who wishes patent protection in another country must apply for a patent in a specific country or in regional patent offices. Applicants may wish to consider the filing of an international application under the Patent Cooperation Treaty (PCT). An international (PCT) application generally has the same effect as a regular national patent application in each PCT-member country. The PCT process **simplifies** the filing of patent applications on the same invention in member countries, but **does not result** in a grant of "an international patent" and does not eliminate the need of applicants to file additional documents and fees in countries where patent protection is desired.

Almost every country has its own patent law, and a person desiring a patent in a particular country must make an application for patent in that country in accordance with its particular laws. Since the laws of many countries differ in various respects from the patent law of the United States, applicants are advised to seek guidance from specific foreign countries to ensure that patent rights are not lost prematurely.

Applicants also are advised that in the case of inventions made in the United States, the Director of the USPTO must issue a license before applicants can apply for a patent in a foreign country. The filing of a U.S. patent application serves as a request for a foreign filing license. The application's filing receipt contains further information and guidance as to the status of applicant's license for foreign filing.

Applicants may wish to consult the USPTO booklet, "General Information Concerning Patents" (specifically, the section entitled "Treaties and Foreign Patents") for more information on timeframes and deadlines for filing foreign patent applications. The guide is available either by contacting the USPTO Contact Center at 800-786-9199, or it can be viewed on the USPTO website at <http://www.uspto.gov/web/offices/pac/doc/general/index.html>.

For information on preventing theft of your intellectual property (patents, trademarks and copyrights), you may wish to consult the U.S. Government website, <http://www.stopfakes.gov>. Part of a Department of Commerce initiative, this website includes self-help "toolkits" giving innovators guidance on how to protect intellectual property in specific countries such as China, Korea and Mexico. For questions regarding patent enforcement issues, applicants may call the U.S. Government hotline at 1-866-999-HALT (1-866-999-4258).

**LICENSE FOR FOREIGN FILING UNDER
Title 35, United States Code, Section 184
Title 37, Code of Federal Regulations, 5.11 & 5.15**

GRANTED

The applicant has been granted a license under 35 U.S.C. 184, if the phrase "IF REQUIRED, FOREIGN FILING LICENSE GRANTED" followed by a date appears on this form. Such licenses are issued in all applications where the conditions for issuance of a license have been met, regardless of whether or not a license may be required as set forth in 37 CFR 5.15. The scope and limitations of this license are set forth in 37 CFR 5.15(a) unless an earlier license has been issued under 37 CFR 5.15(b). The license is subject to revocation upon written notification. The date indicated is the effective date of the license, unless an earlier license of similar scope has been granted under 37 CFR 5.13 or 5.14.

This license is to be retained by the licensee and may be used at any time on or after the effective date thereof unless it is revoked. This license is automatically transferred to any related applications(s) filed under 37 CFR 1.53(d). This license is not retroactive.

The grant of a license does not in any way lessen the responsibility of a licensee for the security of the subject matter as imposed by any Government contract or the provisions of existing laws relating to espionage and the national security or the export of technical data. Licensees should apprise themselves of current regulations especially with respect to certain countries, of other agencies, particularly the Office of Defense Trade Controls, Department of State (with respect to Arms, Munitions and Implements of War (22 CFR 121-128)); the Bureau of Industry and Security, Department of Commerce (15 CFR parts 730-774); the Office of Foreign Assets Control, Department of Treasury (31 CFR Parts 500+) and the Department of Energy.

NOT GRANTED

No license under 35 U.S.C. 184 has been granted at this time, if the phrase "IF REQUIRED, FOREIGN FILING LICENSE GRANTED" DOES NOT appear on this form. Applicant may still petition for a license under 37 CFR 5.12, if a license is desired before the expiration of 6 months from the filing date of the application. If 6 months has lapsed from the filing date of this application and the licensee has not received any indication of a secrecy order under 35 U.S.C. 181, the licensee may foreign file the application pursuant to 37 CFR 5.15(b).

SelectUSA

The United States represents the largest, most dynamic marketplace in the world and is an unparalleled location for business investment, innovation, and commercialization of new technologies. The U.S. offers tremendous resources and advantages for those who invest and manufacture goods here. Through SelectUSA, our nation works to promote and facilitate business investment. SelectUSA provides information assistance to the international investor community; serves as an ombudsman for existing and potential investors; advocates on behalf of U.S. cities, states, and regions competing for global investment; and counsels U.S. economic development organizations on investment attraction best practices. To learn more about why the United States is the best country in the world to develop technology, manufacture products, deliver services, and grow your business, visit <http://www.SelectUSA.gov> or call +1-202-482-6800.



UNITED STATES PATENT AND TRADEMARK OFFICE

UNITED STATES DEPARTMENT OF COMMERCE
United States Patent and Trademark Office
Address: COMMISSIONER FOR PATENTS
P. O. Box 1450
Alexandria, Virginia 22313-1450
www.uspto.gov

Table with 5 columns: APPLICATION NO., ISSUE DATE, PATENT NO., ATTORNEY DOCKET NO., CONFIRMATION NO.
Row 1: 13/476,310, 04/30/2013, 8432956, 6936-2-CON-2-1-4, 7896

62574 7590 04/10/2013
Jason H. Vick
Sheridan Ross, PC
Suite # 1200
1560 Broadway
Denver, CO 80202

ISSUE NOTIFICATION

The projected patent number and issue date are specified above.

Determination of Patent Term Adjustment under 35 U.S.C. 154 (b)
(application filed on or after May 29, 2000)

The Patent Term Adjustment is 0 day(s). Any patent to issue from the above-identified application will include an indication of the adjustment on the front page.

If a Continued Prosecution Application (CPA) was filed in the above-identified application, the filing date that determines Patent Term Adjustment is the filing date of the most recent CPA.

Applicant will be able to obtain more detailed information by accessing the Patent Application Information Retrieval (PAIR) WEB site (http://pair.uspto.gov).

Any questions regarding the Patent Term Extension or Adjustment determination should be directed to the Office of Patent Legal Administration at (571)-272-7702. Questions relating to issue and publication fee payments should be directed to the Application Assistance Unit (AAU) of the Office of Data Management (ODM) at (571)-272-4200.

APPLICANT(s) (Please see PAIR WEB site http://pair.uspto.gov for additional applicants):

David M. Krinsky, Acton, MA;
Robert Edmund Pizzano JR., Stoneham, MA;

The United States represents the largest, most dynamic marketplace in the world and is an unparalleled location for business investment, innovation, and commercialization of new technologies. The USA offers tremendous resources and advantages for those who invest and manufacture goods here. Through SelectUSA, our nation works to encourage and facilitate business investment. To learn more about why the USA is the best country in the world to develop technology, manufacture products, and grow your business, visit SelectUSA.gov.

Change(s) applied
to document,
/D.H.P./
2/8/2013

- 3 -

other known or later developed diagnostic or test information that may be appropriate for the particular communications environment. For example, the exchanged diagnostic and test information can be directed toward specific limitations of the modems, to information relating to the modem installation and deployment environment, or to other diagnostic and test information that can, for example, be determined as needed which may aid in evaluating the cause of a specific failure or problem. Alternatively, the diagnostic and test information can include the loop length and bridged tap length estimations as discussed in copending ⁰⁹⁷⁵⁵¹⁷² ~~Attorney Docket No. 081313-000003~~, filed herewith and incorporated herein by reference in its entirety.

10 For example, an exemplary embodiment of the invention illustrates the use of the diagnostic link mode in the communication of diagnostic information from the remote terminal (RT) transceiver, e.g., ATU-R, to the central office (CO) transceiver, e.g., ATU-C. Transmission of information from the remote terminal to the central office is important since a typical ADSL service provider is located in the central office and would therefore benefit
15 from the ability to determine problems at the remote terminal without a truckroll. However, it is to be appreciated, that the systems and the methods of this invention will work equally well in communications from the central office to the remote terminal.

These and other features and advantages of this invention are described in or are apparent from the following detailed description of the embodiments.

20

BRIEF DESCRIPTION OF THE DRAWINGS

The embodiments of the invention will be described in detail, with reference to the following figures wherein:

25 Fig. 1 is a functional block diagram illustrating an exemplary communications system according to this invention; and

Fig. 2 is a flowchart outlining an exemplary method for communicating diagnostic and test information according to this invention.

DETAILED DESCRIPTION OF THE INVENTION

30 For ease of illustration the following description will be described in relation to the CO receiving diagnostic and test information from the RT. In the exemplary embodiment, the systems and methods of this invention complete a portion of the normal modem initialization before entering into the diagnostic link mode. The systems and methods of this invention can enter the diagnostic link mode manually, for example, at the direction of a

Substitute for form 1449A/PTO				Complete if Known	
INFORMATION DISCLOSURE STATEMENT BY APPLICANT				Application Number	13/476310
				Filing Date	May 21, 2012
				First Named Inventor	David M. Krinsky et al.
				Art Unit	2631
				Examiner Name	KHANH C TRAN
Sheet	1	of	6	Attorney Docket Number	5550-2-CON2-1-4

Change(s) applied

to document,

/D.A.C./
2/25/2013

U.S. PATENT DOCUMENTS						
Examiner Initials*	Cite No. ¹	Document Number Number-kind Code ^{2 (if known)}	Publication Date MM-DD-YYYY	Name of Patentee of Applicant of Cited Document	Pages, Columns, Lines, Where Relevant Passages or Relevant Figures Appear	
/KCT/	1	4385384	05-24-1983	Rosbury et al.		
	2	4566100	01-21-1986	Mizuno et al.		
	3	5128619	07-07-1992	Bjork et al.		
	4	5361293	11-01-1994	Czerwiec		
	5	5608643	03-04-1997	Wichter et al.		
	6	5612960	03-18-1997	Stevens et al.		
	7	5864602	01-26-1999	Needle		
	8	5964891	10-12-1999	Caswell et al.		
	9	6073179	06-06-2000	Liu et al.		
	10	6075821	06-13-2000	Kao et al.		
	11	6175934	01-16-2001	Hershey et al.		
	12	6188717	02-13-2001	Kaiser et al.		
	13	6219378	04-17-2001	Wu		
	14	6249543	06-19-2001	Chow		
	15	6404774	06-11-2002	Jenness		
	16	6411678	06-25-2002	Tomlinson, Jr. et al.		
	17	6445773	09-03-2002	Liang et al.		
	18	6449307	09-10-2002	Ishikawa et al.		
	19	6512789	01-28-2003	Mirfakhraei		
	20	6631120	10-07-2003	Milbrandt		
	21	6633545	10-14-2003	Milbrandt		
	22	6636603	10-21-2003	Milbrandt		
	23	6658052	12-02-2003	Krinsky et al.		
	24	6725176	04-01-20-2004	Long et al.		
	25	6781513	08-24-2004	Korkosz et al.		
	26	7570686	08-04-2009	Krinsky et al.		
	27	7835430	11-16-2010	Krinsky et al.		
	28	7889784	02-15-2011	Krinsky et al.		
	29	2010/0226418	09-09-2010	Krinsky et al.		
/KCT/	30	2011/0103443	05-05-2011	Krinsky et al.		

Change(s) applied

to document,

/J.E./
2/2/2013

Examiner Signature	/Khanh Tran/ (10/27/2012)	Date Considered	10/27/2012
--------------------	---------------------------	-----------------	------------

*EXAMINER: Initial if reference is considered, whether or not citation is in conformance and not considered. Include copy of this form with next communication to applicant.

ALL REFERENCES CONSIDERED EXCEPT WHERE LINED THROUGH. /KCT/



UNITED STATES PATENT AND TRADEMARK OFFICE

UNITED STATES DEPARTMENT OF COMMERCE
United States Patent and Trademark Office
Address: COMMISSIONER FOR PATENTS
P.O. Box 1450
Alexandria, Virginia 22313-1450
www.uspto.gov

APPLICATION NO.	FILING DATE	FIRST NAMED INVENTOR	ATTORNEY DOCKET NO.	CONFIRMATION NO.
13/476,310	05/21/2012	David M. Krinsky	6936-2-CON-2-1-4	7896
62574	7590	04/03/2013	EXAMINER	
Jason H. Vick Sheridan Ross, PC Suite # 1200 1560 Broadway Denver, CO 80202			TRAN, KHANH C	
			ART UNIT	PAPER NUMBER
			2631	
			NOTIFICATION DATE	DELIVERY MODE
			04/03/2013	ELECTRONIC

Please find below and/or attached an Office communication concerning this application or proceeding.

The time period for reply, if any, is set in the attached communication.

Notice of the Office communication was sent electronically on above-indicated "Notification Date" to the following e-mail address(es):

jvick@sheridanross.com

Supplemental Notice of Allowability	Application No. 13/476,310	Applicant(s) KRINSKY ET AL.	
	Examiner KHANH C. TRAN	Art Unit 2631	AIA (First Inventor to File) Status No

-- The MAILING DATE of this communication appears on the cover sheet with the correspondence address--

All claims being allowable, PROSECUTION ON THE MERITS IS (OR REMAINS) CLOSED in this application. If not included herewith (or previously mailed), a Notice of Allowance (PTOL-85) or other appropriate communication will be mailed in due course. **THIS NOTICE OF ALLOWABILITY IS NOT A GRANT OF PATENT RIGHTS.** This application is subject to withdrawal from issue at the initiative of the Office or upon petition by the applicant. See 37 CFR 1.313 and MPEP 1308.

1. This communication is responsive to the IDS and Amendment After Notice of Allowance filed 3/25/2013.
 A declaration(s)/affidavit(s) under **37 CFR 1.130(b)** was/were filed on ____.
2. An election was made by the applicant in response to a restriction requirement set forth during the interview on ____; the restriction requirement and election have been incorporated into this action.
3. The allowed claim(s) is/are _____. As a result of the allowed claim(s), you may be eligible to benefit from the **Patent Prosecution Highway** program at a participating intellectual property office for the corresponding application. For more information, please see http://www.uspto.gov/patents/init_events/pph/index.jsp or send an inquiry to PPHfeedback@uspto.gov.
4. Acknowledgment is made of a claim for foreign priority under 35 U.S.C. § 119(a)-(d) or (f).

Certified copies:

- a) All b) Some *c) None of the:
1. Certified copies of the priority documents have been received.
 2. Certified copies of the priority documents have been received in Application No. _____.
 3. Copies of the certified copies of the priority documents have been received in this national stage application from the International Bureau (PCT Rule 17.2(a)).
- * Certified copies not received: _____.

Interim copies:

- a) All b) Some c) None of the: Interim copies of the priority documents have been received.

Applicant has THREE MONTHS FROM THE "MAILING DATE" of this communication to file a reply complying with the requirements noted below. Failure to timely comply will result in ABANDONMENT of this application. **THIS THREE-MONTH PERIOD IS NOT EXTENDABLE.**

5. CORRECTED DRAWINGS (as "replacement sheets") must be submitted.
 including changes required by the attached Examiner's Amendment / Comment or in the Office action of Paper No./Mail Date _____.
Identifying indicia such as the application number (see 37 CFR 1.84(c)) should be written on the drawings in the front (not the back) of each sheet. Replacement sheet(s) should be labeled as such in the header according to 37 CFR 1.121(d).
6. DEPOSIT OF and/or INFORMATION about the deposit of BIOLOGICAL MATERIAL must be submitted. Note the attached Examiner's comment regarding REQUIREMENT FOR THE DEPOSIT OF BIOLOGICAL MATERIAL.

Attachment(s)

- | | |
|--|---|
| 1. <input type="checkbox"/> Notice of References Cited (PTO-892) | 5. <input type="checkbox"/> Examiner's Amendment/Comment |
| 2. <input checked="" type="checkbox"/> Information Disclosure Statements (PTO/SB/08),
Paper No./Mail Date _____ | 6. <input type="checkbox"/> Examiner's Statement of Reasons for Allowance |
| 3. <input type="checkbox"/> Examiner's Comment Regarding Requirement for Deposit
of Biological Material | 7. <input checked="" type="checkbox"/> Other <u>PTO-90C</u> . |
| 4. <input type="checkbox"/> Interview Summary (PTO-413),
Paper No./Mail Date _____. | |

/KHANH C TRAN/
Primary Examiner, Art Unit 2631



UNITED STATES DEPARTMENT OF COMMERCE

U.S. Patent and Trademark Office

Address : COMMISSIONER FOR PATENTS
P.O. Box 1450
Alexandria, Virginia 22313-1450

APPLICATION NO./ CONTROL NO.	FILING DATE	FIRST NAMED INVENTOR / PATENT IN REEXAMINATION	ATTORNEY DOCKET NO.
13/476,310	21 May, 2012	KRINSKY ET AL.	6936-2-CON-2-1-4

Jason H. Vick Sheridan Ross, PC Suite # 1200 1560 Broadway Denver, CO 80202	EXAMINER	
	KHANH C. TRAN	
	ART UNIT	PAPER
	2631	20130328

DATE MAILED:

Please find below and/or attached an Office communication concerning this application or proceeding.

Commissioner for Patents

This communication is responsive to the Amendment After Notice of Allowance and the IDS filed on 3/25/2013. The IDS has been considered and entered. The Amendment to the Specification has been entered.

/KHANH C TRAN/
Primary Examiner, Art Unit 2631

Substitute for form 1449A/PTO				Complete if Known	
INFORMATION DISCLOSURE STATEMENT BY APPLICANT				Application Number	13/476310
				Filing Date	May 21, 2012
				First Named Inventor	David M. Krinsky et al.
				Art Unit	2631
				Examiner Name	TRAN, Khanh C.
Sheet	1	of	1	Attorney Docket Number	6936-2-CON-2-1-4

U.S. PATENT DOCUMENTS						
Examiner Initials*	Cite No. ¹	Document Number Number-kind Code ² (if known)	Publication Date MM-DD-YYYY	Name of Patentee or Applicant of Cited Document	Pages, Columns, Lines, Where Relevant Passages or Relevant Figures Appear	

FOREIGN PATENT DOCUMENTS						
Examiner Initials*	Cite No. ¹	Foreign Patent Document Country Code ³ ; Number ⁴ ; Kind Code ⁵ (if known)	Publication Date MM-DD-YYYY	Name of Patentee or Applicant of Cited Document	Pages, Columns, Lines, Where Relevant Passages or Relevant Figures Appear	T ⁶

OTHER ART (Including Author, Title, Date, Pertinent Pages, etc.)		
Examiner Initials*	Cite No. ¹	
	1	Decision of Refusal (including translation) for Japanese Patent Application No. 2011-012155, mailed February 25, 2013 (Attorney Ref. No.: 6936-2-PJP-DIV-2)

Examiner Signature	/Khanh Tran/ (03/28/2013)	Date Considered	03/28/2013
--------------------	---------------------------	-----------------	------------

*EXAMINER: Initial if reference is considered, whether or not citation is in conformance and not considered. Include copy of this form with next communication to applicant.

ALL REFERENCES CONSIDERED EXCEPT WHERE LINED THROUGH. /KCT/

IN THE UNITED STATES PATENT AND TRADEMARK OFFICE

In Re the Application of: David M. Krinsky) Group Art Unit: 2631
Application No.: 13/476,310) Examiner: TRAN, Khanh C.
Filed: May 21, 2012) Confirmation No.: 7896
Atty. File No.: 6936-2-CON-2-1-4)

For: Multicarrier Modulation Messaging for Power Level Per Subchannel Information

**NOTIFICATION OF LOSS OF ENTITLEMENT OF
SMALL ENTITY STATUS UNDER
37 CFR §§ 1.27 (g)(2) and 1.28(c)**

Commissioner for Patents
P.O. Box 1450
Alexandria, VA 22313-1450

Madam:

On November 5, 2012, Applicants filed an Assertion of Entitlement to Small Entity Status in the referenced application. Applicants filed the Assertion in good faith, and paid the fees associated with the application as a small entity in good faith. It was later discovered that the Applicant should not have been entitled to small entity status and the Assertion was established in error.

Pursuant to 37 CFR §§ 1.27(g)(2) and 1.28(c), Applicants are informing the Office that the referenced application is no longer entitled to Small Entity Status.

Furthermore, pursuant to 37 C.F.R. §1.28(c)(1)(2), on November 19, 2012, Applicants submitted payment of \$80 at the small entity rate for the following:

- Terminal Disclaimer – \$80

The current fees for the referenced payments are listed below for a total of \$160:

- Terminal Disclaimer – \$160

Therefore, the Commissioner is hereby authorized to charge to deposit account number 19-1970 **\$80.00** for the deficiency owed.

The Commissioner is also hereby authorized to charge to deposit account number 19-1970 any fees under 37 CFR § 1.16 and 1.17 that may be required by this paper and to credit any overpayment to that Account.

Respectfully submitted,
SHERIDAN ROSS P.C.

Date: March 25, 2013

By: /Jason H. Vick/
Jason H. Vick
Reg. No. 45,285
1560 Broadway, Suite 1200
Denver, Colorado 80202
Telephone: 303-863-9700

Electronic Acknowledgement Receipt

EFS ID:	15345750
Application Number:	13476310
International Application Number:	
Confirmation Number:	7896
Title of Invention:	Multicarrier Modulation Messaging for Power Level Per Subchannel Information
First Named Inventor/Applicant Name:	David M. Krinsky
Customer Number:	62574
Filer:	Jason Vick/Joanne Vos
Filer Authorized By:	Jason Vick
Attorney Docket Number:	6936-2-CON-2-1-4
Receipt Date:	25-MAR-2013
Filing Date:	21-MAY-2012
Time Stamp:	16:12:56
Application Type:	Utility under 35 USC 111(a)

Payment information:

Submitted with Payment	no
------------------------	----

File Listing:

Document Number	Document Description	File Name	File Size(Bytes)/ Message Digest	Multi Part /.zip	Pages (if appl.)
1	Notification of loss of entitlement to small entity status	Loss_of_Entitlement_of_Small_Entity_Status.pdf	85397 <small>36cea1d3f5e7f541d63cb2633c227218eca4beab</small>	no	2

Warnings:

Information:

This Acknowledgement Receipt evidences receipt on the noted date by the USPTO of the indicated documents, characterized by the applicant, and including page counts, where applicable. It serves as evidence of receipt similar to a Post Card, as described in MPEP 503.

New Applications Under 35 U.S.C. 111

If a new application is being filed and the application includes the necessary components for a filing date (see 37 CFR 1.53(b)-(d) and MPEP 506), a Filing Receipt (37 CFR 1.54) will be issued in due course and the date shown on this Acknowledgement Receipt will establish the filing date of the application.

National Stage of an International Application under 35 U.S.C. 371

If a timely submission to enter the national stage of an international application is compliant with the conditions of 35 U.S.C. 371 and other applicable requirements a Form PCT/DO/EO/903 indicating acceptance of the application as a national stage submission under 35 U.S.C. 371 will be issued in addition to the Filing Receipt, in due course.

New International Application Filed with the USPTO as a Receiving Office

If a new international application is being filed and the international application includes the necessary components for an international filing date (see PCT Article 11 and MPEP 1810), a Notification of the International Application Number and of the International Filing Date (Form PCT/RO/105) will be issued in due course, subject to prescriptions concerning national security, and the date shown on this Acknowledgement Receipt will establish the international filing date of the application.

PART B - FEE(S) TRANSMITTAL

Complete and send this form, together with applicable fee(s), to: **Mail Stop ISSUE FEE
Commissioner for Patents
P.O. Box 1450
Alexandria, Virginia 22313-1450**
or **Fax (571)-273-2885**

INSTRUCTIONS: This form should be used for transmitting the ISSUE FEE and PUBLICATION FEE (if required). Blocks 1 through 5 should be completed where appropriate. All further correspondence including the Patent, advance orders and notification of maintenance fees will be mailed to the current correspondence address as indicated unless corrected below or directed otherwise in Block 1, by (a) specifying a new correspondence address; and/or (b) indicating a separate "FEE ADDRESS" for maintenance fee notifications.

CURRENT CORRESPONDENCE ADDRESS (Note: Use Block 1 for any change of address)

Note: A certificate of mailing can only be used for domestic mailings of the Fee(s) Transmittal. This certificate cannot be used for any other accompanying papers. Each additional paper, such as an assignment or formal drawing, must have its own certificate of mailing or transmission.

62574 7590 01/04/2013
Jason H. Vick
Sheridan Ross, PC
Suite # 1200
1560 Broadway
Denver, CO 80202

Certificate of Mailing or Transmission
I hereby certify that this Fee(s) Transmittal is being deposited with the United States Postal Service with sufficient postage for first class mail in an envelope addressed to the Mail Stop ISSUE FEE address above, or being facsimile transmitted to the USPTO (571) 273-2885, on the date indicated below.

(Depositor's name)
(Signature)
(Date)

APPLICATION NO.	FILING DATE	FIRST NAMED INVENTOR	ATTORNEY DOCKET NO.	CONFIRMATION NO.
13/476,310	05/21/2012	David M. Krinsky	6936-2-CON-2-1-4	7896
TITLE OF INVENTION: Multicarrier Modulation Messaging for Power Level Per Subchannel Information				

APPLN. TYPE	SMALL ENTITY	ISSUE FEE DUE	PUBLICATION FEE DUE	PREV. PAID ISSUE FEE	TOTAL FEE(S) DUE	DATE DUE
nonprovisional	YES	\$885	\$300	\$0	\$1185	04/04/2013
EXAMINER	ART UNIT	CLASS-SUBCLASS				
TRAN, KHANH C	2631	375-222000				

1. Change of correspondence address or indication of "Fee Address" (37 CFR 1.363).
 Change of correspondence address (or Change of Correspondence Address form PTO/SB/122) attached.
 "Fee Address" indication (or "Fee Address" Indication form PTO/SB/47; Rev 03-02 or more recent) attached. **Use of a Customer Number is required.**

2. For printing on the patent front page, list
 (1) the names of up to 3 registered patent attorneys or agents OR, alternatively,
 (2) the name of a single firm (having as a member a registered attorney or agent) and the names of up to 2 registered patent attorneys or agents. If no name is listed, no name will be printed.

1. Jason H. Vick
 2. Sheridan Ross, PC
 3.

3. ASSIGNEE NAME AND RESIDENCE DATA TO BE PRINTED ON THE PATENT (print or type)
PLEASE NOTE: Unless an assignee is identified below, no assignee data will appear on the patent. If an assignee is identified below, the document has been filed for recordation as set forth in 37 CFR 3.11. Completion of this form is NOT a substitute for filing an assignment.

(A) NAME OF ASSIGNEE: TQ DELTA, LLC
 (B) RESIDENCE: (CITY and STATE OR COUNTRY): AUSTIN, TEXAS

Please check the appropriate assignee category or categories (will not be printed on the patent): Individual Corporation or other private group entity Government

4a. The following fee(s) are submitted:
 Issue Fee
 Publication Fee (No small entity discount permitted)
 Advance Order - # of Copies _____

4b. Payment of Fee(s): (Please first reapply any previously paid issue fee shown above)
 A check is enclosed.
 Payment by credit card. Form PTO-2038 is attached.
 The Director is hereby authorized to charge the required fee(s), any deficiency, or credit any overpayment, to Deposit Account Number 19-1970 (enclose an extra copy of this form).

5. **Change in Entity Status** (from status indicated above)
 a. Applicant claims SMALL ENTITY status. See 37 CFR 1.27.
 b. Applicant is no longer claiming SMALL ENTITY status. See 37 CFR 1.27(g)(2).

NOTE: The Issue Fee and Publication Fee (if required) will not be accepted from anyone other than the applicant; a registered attorney or agent; or the assignee or other party in interest as shown by the records of the United States Patent and Trademark Office.

Authorized Signature _____ Date 25 Mar '13
 Typed or printed name Jason H. Vick Registration No. 45,285

This collection of information is required by 37 CFR 1.311. The information is required to obtain or retain a benefit by the public which is to file (and by the USPTO to process) an application. Confidentiality is governed by 35 U.S.C. 122 and 37 CFR 1.14. This collection is estimated to take 12 minutes to complete, including gathering, preparing, and submitting the completed application form to the USPTO. Time will vary depending upon the individual case. Any comments on the amount of time you require to complete this form and/or suggestions for reducing this burden, should be sent to the Chief Information Officer, U.S. Patent and Trademark Office, U.S. Department of Commerce, P.O. Box 1450, Alexandria, Virginia 22313-1450. **DO NOT SEND FEES OR COMPLETED FORMS TO THIS ADDRESS. SEND TO: Commissioner for Patents, P.O. Box 1450, Alexandria, Virginia 22313-1450.**

Under the Paperwork Reduction Act of 1995, no persons are required to respond to a collection of information unless it displays a valid OMB control number.

IN THE UNITED STATES PATENT AND TRADEMARK OFFICE

In Re the Application of: David M. Krinsky) Group Art Unit: 2631
Application No.: 13/476,310) Examiner: TRAN, Khanh C.
Filed: May 21, 2012) Confirmation No.: 7896
Atty. File No.: 6936-2-CON-2-1-4)

For: MULTICARRIER MODULATION MESSAGING FOR POWER LEVEL PER
SUBCHANNEL INFORMATION

COMMENTS ON STATEMENT OF REASONS FOR ALLOWANCE

Commissioner for Patents
P.O. Box 1450
Alexandria, VA 22313

Madam:

Applicant submits this Comments on Statement of Reasons for Allowance to address further the Notice of Allowability (“Notice”) having a mailing date of January 4, 2013.

In the Notice, the Examiner’s stated reasons for allowance were that:

The following is an examiner’s statement of reasons for allowance:

Claims are allowable over prior art of record because the cited references either singularly or in combination cannot teach or suggest uniquely distinct features used in combination of other claimed elements “**the message comprises one or more data variables that represent the diagnostic information, wherein bits in the message are modulated onto DMT symbols using Quadrature Amplitude Modulation (QAM) with more than 1 bit per subchannel and wherein at least one data variable of the one or more data variables comprises an array representing power level per subchannel information**”.

Based on the Notice, the patentability of all other independent and dependent claims is assumed to be based upon the elements as set forth in such claims and that such claims meet all criteria for patentability under §101, §102, §103 and §112.

As is clear from MPEP 1302.14,

“The statement [of reasons for allowance] is not intended to necessarily state all the reasons for allowance or all the details why claims are allowed and should not be written to specifically or impliedly state that all the reasons for allowance are set forth.”

While the stated Reasons for Allowance may be a stated reason for allowing some independent claims, Applicant submits that some independent claims have a different reason for allowance and that some independent claims have other reasons for allowance.

Specifically, the prior art fails to teach the specific combination of features as recited in the independent claims 44, 46, 48, 50, and 52.

Although the Applicant believes that no fees are due for filing this Comments on Statement of Reasons for Allowance, please charge any fees deemed necessary to Deposit Account No. 19-1970.

Respectfully submitted,

SHERIDAN ROSS P.C.

Date: 25 Mar 13

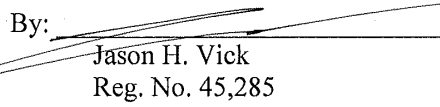
By: 
Jason H. Vick
Reg. No. 45,285
1560 Broadway, Suite 1200
Denver, Colorado 80202
Telephone: 303-863-9700

IN THE UNITED STATES PATENT AND TRADEMARK OFFICE

In Re the Application of: David M. Krinsky) Group Art Unit: 2631)))))
Application No.: 13/476,310	
Filed: May 21, 2012	
Atty. File No.: 6936-2-CON-2-1-4	

For: MULTICARRIER MODULATION MESSAGING FOR POWER LEVEL PER SUBCHANNEL INFORMATION

**AMENDMENT AFTER ALLOWANCE UNDER
37 C.F.R. 1.312**

Commissioner for Patents
P.O. Box 1450
Alexandria, VA 22313-1450

Madam:

Applicants submit this Amendment After Allowance pursuant to 37 C.F.R. 1.312 in response to the Notice of Allowance having a mailing date of January 4, 2013. While Applicants believe that no fees are due with the filing of this response, the undersigned hereby authorizes the charge of any fees deemed necessary to Deposit Account No. 19-1970.

An amendment may be entered after the mailing of a Notice of Allowance but prior to payment of the issue fee upon recommendation of the primary Examiner. Therefore, it is respectfully requested that the above-referenced application be amended as follows:

Amendments to the Specification begin on page 2 of this paper.

Remarks begin on page 3 of this paper.

AMENDMENTS TO THE SPECIFICATION

Please amend the first paragraph immediately following the title with the following:

Related Application Data

This application is a continuation of U.S. Application No. 12/779,660, filed May 13, 2012, now U.S. Patent No. 8,238,412, which is a continuation of U.S. Application No. 12/477,742, filed June 3, 2009, now U.S. Patent No. 7,835,430, which is a continuation of U.S. Application No. 10/619,691, filed July 16, 2003, now U.S. Patent No. 7,570,686, which is a continuation of U.S. Application No. 09/755,173, filed January 8, 2001, now U.S. Patent No. 6,658,052, which claims the benefit of and priority under 35 U.S.C. § 119(e) to U.S. Provisional Application No. 60/224,308, filed August 10, 2000 entitled "Characterization of transmission lines using broadband signals in a multi-carrier DSL system," and U.S. Provisional Application No. 60/174,865, filed January 7, 2000 entitled "Multicarrier Modulation System with Remote Diagnostic Transmission Mode", each of which are incorporated herein by reference in their entirety.

On page 3, lines 1-9, of the originally filed specification, please amend the following:

other known or later developed diagnostic or test information that may be appropriate for the particular communications environment. For example, the exchanged diagnostic and test information can be directed toward specific limitations of the modems, to information relating to the modem installation and deployment environment, or to other diagnostic and test information that can, for example, be determined as needed which may aid in evaluating the cause of a specific failure or problem. Alternatively, the diagnostic and test information can include the loop length and bridged tap length estimations as discussed in U.S. patent application No. 09/755,172, now U.S. Patent No. 6,865,221 (pending Attorney Docket No. 081513-000003, filed herewith and incorporated herein by reference in its entirety.

REMARKS

By this amendment, the Cross-Reference to Related Applications has been updated and minor typographical errors have been corrected. No new matter is believed to be introduced by this amendment.

The Commissioner is hereby authorized to charge to deposit account number 19-1970 any fees under 37 CFR § 1.16 and 1.17 that may be required by this paper and to credit any overpayment to that Account. If any extension of time is required in connection with the filing of this paper and has not been separately requested, such extension is hereby petitioned.

Respectfully submitted,

SHERIDAN ROSS P.C.

Date: 25 Mar 13

By: 

Jason H. Vick
Reg. No. 45,285
1560 Broadway, Suite 1200
Denver, Colorado 80202
Telephone: 303-863-9700

IN THE UNITED STATES PATENT AND TRADEMARK OFFICE

In Re the Application of:)	Group Art Unit: 2631
David M. Krinsky et al.)	Confirmation No.: 7896
Serial No.: 13/476,310)	Examiner: TRAN, Khanh C.
Filed: May 21, 2012)	
Atty. File No.: 6936-2-CON-2-1-4)	
Entitled: "MULTICARRIER MODULATION MESSAGING FOR POWER LEVEL PER SUBCHANNEL INFORMATION")	<u>SUPPLEMENTAL</u> <u>INFORMATION DISCLOSURE</u> <u>STATEMENT</u>
)	Electronically Submitted

Commissioner for Patents
P.O. Box 1450
Alexandria, VA 22313-1450

Dear Sir:

The references cited on attached Form PTO-1449 are being called to the attention of the Examiner.

- Copies of the cited non-patent and/or foreign references are enclosed herewith.
- Copies of the cited U.S. patents and/or patent applications are enclosed herewith.
- Copies of the cited U.S. patents/patent application publications are not enclosed in accordance with 37 C.F.R. § 1.98(a).
- Copies of the cited references are not enclosed, in accordance with 37 C.F.R. § 1.98(d), because the references were cited by or submitted to the U.S. Patent and Trademark Office in prior application Serial No. _____ filed _____, which is relied upon for an earlier filing date under 35 U.S.C. § 120.
- To the best of applicants' belief, the pertinence of the foreign-language references are believed to be summarized in the attached English translation/abstracts and/or in the figures, although applicants do not necessarily vouch for the accuracy of the translation.
- Examiner's attention is drawn to the following related applications:
 - Serial No. _____ filed _____, (Attorney's Ref. No. _____)
- Other: _____

Submission of the above information is not intended as an admission that any item is citable under the statutes or rules to support a rejection, that any item disclosed represents analogous art, or that those skilled in the art would refer to or recognize the pertinence of any reference without the benefit of hindsight, nor should an inference be drawn as to the pertinence of the references based on the order in which they are presented.

Submission of this statement should not be taken as an indication that a search has been conducted, or that no better art exists.

It is respectfully requested that the cited information be expressly considered during the prosecution of this application and the references made of record therein.

FEEES

<input type="checkbox"/>	<p>37 CFR 1.97(b): No fee is believed due in connection with this submission, because the information disclosure statement submitted herewith is satisfied by one of the following conditions ("X" indicates satisfaction):</p> <p><input type="checkbox"/> Within three months of the filing date of a national application other than a continued prosecution application under 37 CFR 1.53(d), or</p> <p><input type="checkbox"/> Within three months of the date of entry into the national stage of an international application as set forth in 37 CFR 1.491 or</p> <p><input type="checkbox"/> Before the mailing date of a first Office Action on the merits, or</p> <p><input type="checkbox"/> Before the mailing of a first Office action after the filing of a request for continued examination under 37 CFR 1.114.</p> <p>Although no fee is believed due, if any fee is deemed due in connection with this submission, please charge such fee to Deposit Account 19-1970.</p>
<input type="checkbox"/>	<p>37 CFR 1.97(c): The information disclosure statement transmitted herewith is being filed after all the above conditions (37 CFR 1.97(b)), but before the mailing date of one of the following conditions:</p> <p>(1) a final action under 37 C.F.R. 1.113 or</p> <p>(2) a notice of allowance under 37 C.F.R. 1.311, or</p> <p>(3) an action that otherwise closes prosecution in the application.</p> <p>This Information Disclosure Statement is accompanied by:</p> <p><input type="checkbox"/> A Certification (below) as specified by 37 C.F.R. 1.97(c). Although no fee is believed due, if any fee is deemed due in connection with this submission, please charge such fee to Deposit Account 19-1970.</p> <p style="text-align: center;">OR</p> <p><input type="checkbox"/> Please charge Deposit Account 19-1970 in the amount of \$180.00 for the fee set forth in 37 C.F.R. 1.17(p) for submission of an information disclosure statement. Please credit any overpayment or charge any underpayment to Deposit Account 19-1970.</p>
<input checked="" type="checkbox"/>	<p>37 CFR 1.97(d): This Information Disclosure Statement is being submitted after the period specified in 37 CFR 1.97(c).</p> <p><input checked="" type="checkbox"/> This information Disclosure Statement includes a Certification (below) as specified by 37 C.F.R. 1.97(e)</p> <p style="text-align: center;">AND</p> <p><input checked="" type="checkbox"/> Applicants hereby requests consideration of the reference(s) disclosed herein. Please charge Deposit Account 19-1970 in the amount of \$180.00 under 37 C.F.R. 1.17(p). Please credit any overpayment or charge any underpayment to Deposit Account 19-1970. Election to pay the fee should not be taken as an indication that applicant(s) cannot execute a certification.</p>

Certification (37 C.F.R. 1.97(e))
(Applicable only if checked)

- The undersigned certifies that:
- Each item of information contained in this information disclosure statement was first cited in any communication from a foreign patent office in a counterpart foreign application not more than three months prior to the filing of this statement. 37 C.F.R. 1.97(e)(1).
 - A copy of the communication from the foreign patent office is enclosed.

OR

- No item of information contained in this information disclosure statement was cited in a communication from a foreign patent office in a counterpart foreign application, and, to the knowledge of the undersigned after making reasonable inquiry, no item of information contained in this Information Disclosure Statement was known to any individual designated in 37 C.F.R. 1.56(c) more than three months prior to the filing of this statement. 37 C.F.R. 1.97(e)(2).

Respectfully submitted,

SHERIDAN ROSS P.C.

By: _____

Jason H. Vick
Registration No. 45,285
1560 Broadway, Suite 1200
Denver, Colorado 80202-5141
(303) 863-9700

Date: 25 MAR 13

Substitute for form 1449A/PTO				Complete if Known	
INFORMATION DISCLOSURE STATEMENT BY APPLICANT				Application Number	13/476310
				Filing Date	May 21, 2012
				First Named Inventor	David M. Krinsky et al.
				Art Unit	2631
				Examiner Name	TRAN, Khanh C.
Sheet	1	of	1	Attorney Docket Number	6936-2-CON-2-1-4

U.S. PATENT DOCUMENTS					
Examiner Initials*	Cite No. ¹	Document Number Number-kind Code ² (if known)	Publication Date MM-DD-YYYY	Name of Patentee or Applicant of Cited Document	Pages, Columns, Lines, Where Relevant Passages or Relevant Figures Appear

FOREIGN PATENT DOCUMENTS						
Examiner Initials*	Cite No. ¹	Foreign Patent Document Country Code ³ ; Number ⁴ ; Kind Code ⁵ (if known)	Publication Date MM-DD-YYYY	Name of Patentee or Applicant of Cited Document	Pages, Columns, Lines, Where Relevant Passages or Relevant Figures Appear	T ⁶

OTHER ART (Including Author, Title, Date, Pertinent Pages, etc.)		
Examiner Initials*	Cite No. ¹	
	1	Decision of Refusal (including translation) for Japanese Patent Application No. 2011-012155, mailed February 25, 2013 (Attorney Ref. No.: 6936-2-PJP-DIV-2)

Examiner Signature		Date Considered	
--------------------	--	-----------------	--

*EXAMINER: Initial if reference is considered, whether or not citation is in conformance and not considered. Include copy of this form with next communication to applicant.

Electronic Patent Application Fee Transmittal

Application Number:	13476310			
Filing Date:	21-May-2012			
Title of Invention:	Multicarrier Modulation Messaging for Power Level Per Subchannel Information			
First Named Inventor/Applicant Name:	David M. Krinsky			
Filer:	Jason Vick/Joanne Vos			
Attorney Docket Number:	6936-2-CON-2-1-4			
Filed as Large Entity				
Utility under 35 USC 111(a) Filing Fees				
Description	Fee Code	Quantity	Amount	Sub-Total in USD(\$)
Basic Filing:				
Pages:				
Claims:				
Miscellaneous-Filing:				
Petition:				
Patent-Appeals-and-Interference:				
Post-Allowance-and-Post-Issuance:				
Utility Appl Issue Fee	1501	1	1780	1780
Publ. Fee- Early, Voluntary, or Normal	1504	1	300	300

Description	Fee Code	Quantity	Amount	Sub-Total in USD(\$)
Extension-of-Time:				
Miscellaneous:				
Submission- Information Disclosure Stmt	1806	1	180	180
Total in USD (\$)				2260

Electronic Acknowledgement Receipt

EFS ID:	15346945
Application Number:	13476310
International Application Number:	
Confirmation Number:	7896
Title of Invention:	Multicarrier Modulation Messaging for Power Level Per Subchannel Information
First Named Inventor/Applicant Name:	David M. Krinsky
Customer Number:	62574
Filer:	Jason Vick/Joanne Vos
Filer Authorized By:	Jason Vick
Attorney Docket Number:	6936-2-CON-2-1-4
Receipt Date:	25-MAR-2013
Filing Date:	21-MAY-2012
Time Stamp:	17:01:50
Application Type:	Utility under 35 USC 111(a)

Payment information:

Submitted with Payment	yes
Payment Type	Deposit Account
Payment was successfully received in RAM	\$ 2260
RAM confirmation Number	4124
Deposit Account	191970
Authorized User	
<p>The Director of the USPTO is hereby authorized to charge indicated fees and credit any overpayment as follows:</p> <p style="padding-left: 40px;">Charge any Additional Fees required under 37 C.F.R. Section 1.16 (National application filing, search, and examination fees)</p> <p style="padding-left: 40px;">Charge any Additional Fees required under 37 C.F.R. Section 1.17 (Patent application and reexamination processing fees)</p>	

Charge any Additional Fees required under 37 C.F.R. Section 1.19 (Document supply fees)					
Charge any Additional Fees required under 37 C.F.R. Section 1.20 (Post Issuance fees)					
Charge any Additional Fees required under 37 C.F.R. Section 1.21 (Miscellaneous fees and charges)					
File Listing:					
Document Number	Document Description	File Name	File Size(Bytes)/ Message Digest	Multi Part /.zip	Pages (if appl.)
1	Issue Fee Payment (PTO-85B)	Issu_Fee_Payment.pdf	156901	no	1
			27b4ee3d2d6b693764bdd7b17deb9386e7a4073		
Warnings:					
Information:					
2	Post Allowance Communication - Incoming	Comments_on_Reason_for_Allowance.pdf	160343	no	2
			6e0f9ed935433113cd59f75eb831cc0a28f2fb		
Warnings:					
Information:					
3		AMEND_312.pdf	230719	yes	3
			c148d8c4476046e19a04041e224de8b36670d1af		
Multipart Description/PDF files in .zip description					
Document Description		Start	End		
Amendment after Notice of Allowance (Rule 312)		1	1		
Specification		2	2		
Applicant Arguments/Remarks Made in an Amendment		3	3		
Warnings:					
Information:					
4		IDS_04.pdf	341064	yes	4
			b771c7a9d24577bc96339da3eae453759d4aa43e		
Multipart Description/PDF files in .zip description					
Document Description		Start	End		
Transmittal Letter		1	3		
Information Disclosure Statement (IDS) Form (SB08)		4	4		
Warnings:					
Information:					
5	Non Patent Literature	6936-2-PJP-DIV-2_OA_02-25-2013.pdf	93467	no	4
			bc62a3c4845ea7b086e974ae3a146c48e44935c4		

Warnings:					
Information:					
6	Fee Worksheet (SB06)	fee-info.pdf	33644	no	2
			1c7dd979293e48480ad74f91a388c0de473f123f		
Warnings:					
Information:					
Total Files Size (in bytes):				1016138	
<p>This Acknowledgement Receipt evidences receipt on the noted date by the USPTO of the indicated documents, characterized by the applicant, and including page counts, where applicable. It serves as evidence of receipt similar to a Post Card, as described in MPEP 503.</p> <p><u>New Applications Under 35 U.S.C. 111</u> If a new application is being filed and the application includes the necessary components for a filing date (see 37 CFR 1.53(b)-(d) and MPEP 506), a Filing Receipt (37 CFR 1.54) will be issued in due course and the date shown on this Acknowledgement Receipt will establish the filing date of the application.</p> <p><u>National Stage of an International Application under 35 U.S.C. 371</u> If a timely submission to enter the national stage of an international application is compliant with the conditions of 35 U.S.C. 371 and other applicable requirements a Form PCT/DO/EO/903 indicating acceptance of the application as a national stage submission under 35 U.S.C. 371 will be issued in addition to the Filing Receipt, in due course.</p> <p><u>New International Application Filed with the USPTO as a Receiving Office</u> If a new international application is being filed and the international application includes the necessary components for an international filing date (see PCT Article 11 and MPEP 1810), a Notification of the International Application Number and of the International Filing Date (Form PCT/RO/105) will be issued in due course, subject to prescriptions concerning national security, and the date shown on this Acknowledgement Receipt will establish the international filing date of the application.</p>					



NOTICE OF ALLOWANCE AND FEE(S) DUE

62574 7590 01/04/2013
Jason H. Vick
Sheridan Ross, PC
Suite # 1200
1560 Broadway
Denver, CO 80202

EXAMINER

TRAN, KHANH C

ART UNIT PAPER NUMBER

2631

DATE MAILED: 01/04/2013

Table with 5 columns: APPLICATION NO., FILING DATE, FIRST NAMED INVENTOR, ATTORNEY DOCKET NO., CONFIRMATION NO.
13/476,310 05/21/2012 David M. Krinsky 6936-2-CON-2-1-4 7896

TITLE OF INVENTION: Multicarrier Modulation Messaging for Power Level Per Subchannel Information

Table with 7 columns: APPLN. TYPE, SMALL ENTITY, ISSUE FEE DUE, PUBLICATION FEE DUE, PREV. PAID ISSUE FEE, TOTAL FEE(S) DUE, DATE DUE
nonprovisional YES \$885 \$300 \$0 \$1185 04/04/2013

THE APPLICATION IDENTIFIED ABOVE HAS BEEN EXAMINED AND IS ALLOWED FOR ISSUANCE AS A PATENT. PROSECUTION ON THE MERITS IS CLOSED. THIS NOTICE OF ALLOWANCE IS NOT A GRANT OF PATENT RIGHTS. THIS APPLICATION IS SUBJECT TO WITHDRAWAL FROM ISSUE AT THE INITIATIVE OF THE OFFICE OR UPON PETITION BY THE APPLICANT. SEE 37 CFR 1.313 AND MPEP 1308.

THE ISSUE FEE AND PUBLICATION FEE (IF REQUIRED) MUST BE PAID WITHIN THREE MONTHS FROM THE MAILING DATE OF THIS NOTICE OR THIS APPLICATION SHALL BE REGARDED AS ABANDONED. THIS STATUTORY PERIOD CANNOT BE EXTENDED. SEE 35 U.S.C. 151. THE ISSUE FEE DUE INDICATED ABOVE DOES NOT REFLECT A CREDIT FOR ANY PREVIOUSLY PAID ISSUE FEE IN THIS APPLICATION. IF AN ISSUE FEE HAS PREVIOUSLY BEEN PAID IN THIS APPLICATION (AS SHOWN ABOVE), THE RETURN OF PART B OF THIS FORM WILL BE CONSIDERED A REQUEST TO REAPPLY THE PREVIOUSLY PAID ISSUE FEE TOWARD THE ISSUE FEE NOW DUE.

HOW TO REPLY TO THIS NOTICE:

I. Review the SMALL ENTITY status shown above.

If the SMALL ENTITY is shown as YES, verify your current SMALL ENTITY status:

A. If the status is the same, pay the TOTAL FEE(S) DUE shown above.

B. If the status above is to be removed, check box 5b on Part B - Fee(s) Transmittal and pay the PUBLICATION FEE (if required) and twice the amount of the ISSUE FEE shown above, or

If the SMALL ENTITY is shown as NO:

A. Pay TOTAL FEE(S) DUE shown above, or

B. If applicant claimed SMALL ENTITY status before, or is now claiming SMALL ENTITY status, check box 5a on Part B - Fee(s) Transmittal and pay the PUBLICATION FEE (if required) and 1/2 the ISSUE FEE shown above.

II. PART B - FEE(S) TRANSMITTAL, or its equivalent, must be completed and returned to the United States Patent and Trademark Office (USPTO) with your ISSUE FEE and PUBLICATION FEE (if required). If you are charging the fee(s) to your deposit account, section "4b" of Part B - Fee(s) Transmittal should be completed and an extra copy of the form should be submitted. If an equivalent of Part B is filed, a request to reapply a previously paid issue fee must be clearly made, and delays in processing may occur due to the difficulty in recognizing the paper as an equivalent of Part B.

III. All communications regarding this application must give the application number. Please direct all communications prior to issuance to Mail Stop ISSUE FEE unless advised to the contrary.

IMPORTANT REMINDER: Utility patents issuing on applications filed on or after Dec. 12, 1980 may require payment of maintenance fees. It is patentee's responsibility to ensure timely payment of maintenance fees when due.

PART B - FEE(S) TRANSMITTAL

**Complete and send this form, together with applicable fee(s), to: Mail Mail Stop ISSUE FEE
 Commissioner for Patents
 P.O. Box 1450
 Alexandria, Virginia 22313-1450
 or Fax (571)-273-2885**

INSTRUCTIONS: This form should be used for transmitting the ISSUE FEE and PUBLICATION FEE (if required). Blocks 1 through 5 should be completed where appropriate. All further correspondence including the Patent, advance orders and notification of maintenance fees will be mailed to the current correspondence address as indicated unless corrected below or directed otherwise in Block 1, by (a) specifying a new correspondence address; and/or (b) indicating a separate "FEE ADDRESS" for maintenance fee notifications.

CURRENT CORRESPONDENCE ADDRESS (Note: Use Block 1 for any change of address)

62574 7590 01/04/2013
 Jason H. Vick
 Sheridan Ross, PC
 Suite # 1200
 1560 Broadway
 Denver, CO 80202

Note: A certificate of mailing can only be used for domestic mailings of the Fee(s) Transmittal. This certificate cannot be used for any other accompanying papers. Each additional paper, such as an assignment or formal drawing, must have its own certificate of mailing or transmission.

Certificate of Mailing or Transmission

I hereby certify that this Fee(s) Transmittal is being deposited with the United States Postal Service with sufficient postage for first class mail in an envelope addressed to the Mail Stop ISSUE FEE address above, or being facsimile transmitted to the USPTO (571) 273-2885, on the date indicated below.

_____ (Depositor's name)
_____ (Signature)
_____ (Date)

APPLICATION NO.	FILING DATE	FIRST NAMED INVENTOR	ATTORNEY DOCKET NO.	CONFIRMATION NO.
13/476,310	05/21/2012	David M. Krinsky	6936-2-CON-2-1-4	7896

TITLE OF INVENTION: Multicarrier Modulation Messaging for Power Level Per Subchannel Information

APPLN. TYPE	SMALL ENTITY	ISSUE FEE DUE	PUBLICATION FEE DUE	PREV. PAID ISSUE FEE	TOTAL FEE(S) DUE	DATE DUE
nonprovisional	YES	\$885	\$300	\$0	\$1185	04/04/2013

EXAMINER	ART UNIT	CLASS-SUBCLASS
TRAN, KHANH C	2631	375-222000

1. Change of correspondence address or indication of "Fee Address" (37 CFR 1.363).
 Change of correspondence address (or Change of Correspondence Address form PTO/SB/122) attached.
 "Fee Address" indication (or "Fee Address" Indication form PTO/SB/47; Rev 03-02 or more recent) attached. **Use of a Customer Number is required.**

2. For printing on the patent front page, list
 (1) the names of up to 3 registered patent attorneys or agents OR, alternatively, 1 _____
 (2) the name of a single firm (having as a member a registered attorney or agent) and the names of up to 2 registered patent attorneys or agents. If no name is listed, no name will be printed. 2 _____
 3 _____

3. ASSIGNEE NAME AND RESIDENCE DATA TO BE PRINTED ON THE PATENT (print or type)
 PLEASE NOTE: Unless an assignee is identified below, no assignee data will appear on the patent. If an assignee is identified below, the document has been filed for recordation as set forth in 37 CFR 3.11. Completion of this form is NOT a substitute for filing an assignment.
 (A) NAME OF ASSIGNEE _____ (B) RESIDENCE: (CITY and STATE OR COUNTRY) _____

Please check the appropriate assignee category or categories (will not be printed on the patent) : Individual Corporation or other private group entity Government

4a. The following fee(s) are submitted:
 Issue Fee
 Publication Fee (No small entity discount permitted)
 Advance Order - # of Copies _____

4b. Payment of Fee(s): (Please first reapply any previously paid issue fee shown above)
 A check is enclosed.
 Payment by credit card. Form PTO-2038 is attached.
 The Director is hereby authorized to charge the required fee(s), any deficiency, or credit any overpayment, to Deposit Account Number _____ (enclose an extra copy of this form).

5. **Change in Entity Status** (from status indicated above)
 a. Applicant claims SMALL ENTITY status. See 37 CFR 1.27. b. Applicant is no longer claiming SMALL ENTITY status. See 37 CFR 1.27(g)(2).

NOTE: The Issue Fee and Publication Fee (if required) will not be accepted from anyone other than the applicant; a registered attorney or agent; or the assignee or other party in interest as shown by the records of the United States Patent and Trademark Office.

Authorized Signature _____ Date _____
 Typed or printed name _____ Registration No. _____

This collection of information is required by 37 CFR 1.311. The information is required to obtain or retain a benefit by the public which is to file (and by the USPTO to process) an application. Confidentiality is governed by 35 U.S.C. 122 and 37 CFR 1.14. This collection is estimated to take 12 minutes to complete, including gathering, preparing, and submitting the completed application form to the USPTO. Time will vary depending upon the individual case. Any comments on the amount of time you require to complete this form and/or suggestions for reducing this burden, should be sent to the Chief Information Officer, U.S. Patent and Trademark Office, U.S. Department of Commerce, P.O. Box 1450, Alexandria, Virginia 22313-1450. DO NOT SEND FEES OR COMPLETED FORMS TO THIS ADDRESS. SEND TO: Commissioner for Patents, P.O. Box 1450, Alexandria, Virginia 22313-1450.

Under the Paperwork Reduction Act of 1995, no persons are required to respond to a collection of information unless it displays a valid OMB control number.



UNITED STATES PATENT AND TRADEMARK OFFICE

UNITED STATES DEPARTMENT OF COMMERCE
United States Patent and Trademark Office
Address: COMMISSIONER FOR PATENTS
P.O. Box 1450
Alexandria, Virginia 22313-1450
www.uspto.gov

Table with columns: APPLICATION NO., FILING DATE, FIRST NAMED INVENTOR, ATTORNEY DOCKET NO., CONFIRMATION NO., EXAMINER, ART UNIT, PAPER NUMBER. Includes application details for David M. Krinsky and Jason H. Vick.

DATE MAILED: 01/04/2013

Determination of Patent Term Adjustment under 35 U.S.C. 154 (b)

(application filed on or after May 29, 2000)

The Patent Term Adjustment to date is 0 day(s). If the issue fee is paid on the date that is three months after the mailing date of this notice and the patent issues on the Tuesday before the date that is 28 weeks (six and a half months) after the mailing date of this notice, the Patent Term Adjustment will be 0 day(s).

If a Continued Prosecution Application (CPA) was filed in the above-identified application, the filing date that determines Patent Term Adjustment is the filing date of the most recent CPA.

Applicant will be able to obtain more detailed information by accessing the Patent Application Information Retrieval (PAIR) WEB site (http://pair.uspto.gov).

Any questions regarding the Patent Term Extension or Adjustment determination should be directed to the Office of Patent Legal Administration at (571)-272-7702. Questions relating to issue and publication fee payments should be directed to the Customer Service Center of the Office of Patent Publication at 1-(888)-786-0101 or (571)-272-4200.

Privacy Act Statement

The Privacy Act of 1974 (P.L. 93-579) requires that you be given certain information in connection with your submission of the attached form related to a patent application or patent. Accordingly, pursuant to the requirements of the Act, please be advised that: (1) the general authority for the collection of this information is 35 U.S.C. 2(b)(2); (2) furnishing of the information solicited is voluntary; and (3) the principal purpose for which the information is used by the U.S. Patent and Trademark Office is to process and/or examine your submission related to a patent application or patent. If you do not furnish the requested information, the U.S. Patent and Trademark Office may not be able to process and/or examine your submission, which may result in termination of proceedings or abandonment of the application or expiration of the patent.

The information provided by you in this form will be subject to the following routine uses:

1. The information on this form will be treated confidentially to the extent allowed under the Freedom of Information Act (5 U.S.C. 552) and the Privacy Act (5 U.S.C. 552a). Records from this system of records may be disclosed to the Department of Justice to determine whether disclosure of these records is required by the Freedom of Information Act.
2. A record from this system of records may be disclosed, as a routine use, in the course of presenting evidence to a court, magistrate, or administrative tribunal, including disclosures to opposing counsel in the course of settlement negotiations.
3. A record in this system of records may be disclosed, as a routine use, to a Member of Congress submitting a request involving an individual, to whom the record pertains, when the individual has requested assistance from the Member with respect to the subject matter of the record.
4. A record in this system of records may be disclosed, as a routine use, to a contractor of the Agency having need for the information in order to perform a contract. Recipients of information shall be required to comply with the requirements of the Privacy Act of 1974, as amended, pursuant to 5 U.S.C. 552a(m).
5. A record related to an International Application filed under the Patent Cooperation Treaty in this system of records may be disclosed, as a routine use, to the International Bureau of the World Intellectual Property Organization, pursuant to the Patent Cooperation Treaty.
6. A record in this system of records may be disclosed, as a routine use, to another federal agency for purposes of National Security review (35 U.S.C. 181) and for review pursuant to the Atomic Energy Act (42 U.S.C. 218(c)).
7. A record from this system of records may be disclosed, as a routine use, to the Administrator, General Services, or his/her designee, during an inspection of records conducted by GSA as part of that agency's responsibility to recommend improvements in records management practices and programs, under authority of 44 U.S.C. 2904 and 2906. Such disclosure shall be made in accordance with the GSA regulations governing inspection of records for this purpose, and any other relevant (i.e., GSA or Commerce) directive. Such disclosure shall not be used to make determinations about individuals.
8. A record from this system of records may be disclosed, as a routine use, to the public after either publication of the application pursuant to 35 U.S.C. 122(b) or issuance of a patent pursuant to 35 U.S.C. 151. Further, a record may be disclosed, subject to the limitations of 37 CFR 1.14, as a routine use, to the public if the record was filed in an application which became abandoned or in which the proceedings were terminated and which application is referenced by either a published application, an application open to public inspection or an issued patent.
9. A record from this system of records may be disclosed, as a routine use, to a Federal, State, or local law enforcement agency, if the USPTO becomes aware of a violation or potential violation of law or regulation.

Notice of Allowability	Application No.	Applicant(s)	
	13/476,310	KRINSKY ET AL.	
	Examiner	Art Unit	
	KHANH C. TRAN	2631	

-- The MAILING DATE of this communication appears on the cover sheet with the correspondence address--

All claims being allowable, PROSECUTION ON THE MERITS IS (OR REMAINS) CLOSED in this application. If not included herewith (or previously mailed), a Notice of Allowance (PTOL-85) or other appropriate communication will be mailed in due course. **THIS NOTICE OF ALLOWABILITY IS NOT A GRANT OF PATENT RIGHTS.** This application is subject to withdrawal from issue at the initiative of the Office or upon petition by the applicant. See 37 CFR 1.313 and MPEP 1308.

- This communication is responsive to the Amendment filed 12/3/2012.
- An election was made by the applicant in response to a restriction requirement set forth during the interview on ____; the restriction requirement and election have been incorporated into this action.
- The allowed claim(s) is/are 44-53. As a result of the allowed claim(s), you may be eligible to benefit from the **Patent Prosecution Highway** program at a participating intellectual property office for the corresponding application. For more information, please see http://www.uspto.gov/patents/init_events/pph/index.jsp or send an inquiry to PPHfeedback@uspto.gov.
- Acknowledgment is made of a claim for foreign priority under 35 U.S.C. § 119(a)-(d) or (f).
 - All
 - Some*
 - None
 of the:
 - Certified copies of the priority documents have been received.
 - Certified copies of the priority documents have been received in Application No. ____.
 - Copies of the certified copies of the priority documents have been received in this national stage application from the International Bureau (PCT Rule 17.2(a)).
 * Certified copies not received: ____.

Applicant has THREE MONTHS FROM THE "MAILING DATE" of this communication to file a reply complying with the requirements noted below. Failure to timely comply will result in ABANDONMENT of this application.
THIS THREE-MONTH PERIOD IS NOT EXTENDABLE.

- CORRECTED DRAWINGS (as "replacement sheets") must be submitted.
 - including changes required by the attached Examiner's Amendment / Comment or in the Office action of Paper No./Mail Date ____.**Identifying indicia such as the application number (see 37 CFR 1.84(c)) should be written on the drawings in the front (not the back) of each sheet. Replacement sheet(s) should be labeled as such in the header according to 37 CFR 1.121(d).**
- DEPOSIT OF and/or INFORMATION about the deposit of BIOLOGICAL MATERIAL must be submitted. Note the attached Examiner's comment regarding REQUIREMENT FOR THE DEPOSIT OF BIOLOGICAL MATERIAL.

Attachment(s)

- Notice of References Cited (PTO-892)
- Information Disclosure Statements (PTO/SB/08), Paper No./Mail Date ____
- Examiner's Comment Regarding Requirement for Deposit of Biological Material
- Interview Summary (PTO-413), Paper No./Mail Date ____
- Examiner's Amendment/Comment
- Examiner's Statement of Reasons for Allowance
- Other ____.

/KHANH C TRAN/ Primary Examiner, Art Unit 2631	
---	--

1. The Amendment filed on 3/20/2012 has been entered. Claims 44-64 are still pending in this Office action.

2. Claims 44-64 have been renumbered as claims 1-21, respectively.

Response to Arguments

3. Applicant's arguments, see Applicants' Remarks, filed 3/20/2012, with respect to claims 44-64 have been fully considered and are persuasive. The rejection of claims 44-64 has been withdrawn after Applicants filed Terminal Disclaimers to overcome the outstanding Double Patenting Rejection.

Allowable Subject Matter

The following is an examiner's statement of reasons for allowance:

4. Claims are allowable over prior art of record because the cited references either singularly or in combination cannot teach or suggest uniquely distinct features used in combination of other claimed elements "*the message comprises one or more data variables that represent the diagnostic information, wherein bits in the message are modulated onto DMT symbols using Quadrature Amplitude Modulation (QAM) with more than 1 bit per subchannel and wherein at least one data variable of the one or*

more data variables comprises an array representing power level per subchannel information".

Any comments considered necessary by applicant must be submitted no later than the payment of the issue fee and, to avoid processing delays, should preferably accompany the issue fee. Such submissions should be clearly labeled "Comments on Statement of Reasons for Allowance."

Conclusion

5. Any inquiry concerning this communication or earlier communications from the examiner should be directed to KHANH C. TRAN whose telephone number is (571)272-3007. The examiner can normally be reached on Monday - Friday from 08:00 AM - 05:00 PM.

If attempts to reach the examiner by telephone are unsuccessful, the examiner's supervisor, Shuwang Liu can be reached on 571-272-3036. The fax phone number for the organization where this application or proceeding is assigned is 571-273-8300.

Information regarding the status of an application may be obtained from the Patent Application Information Retrieval (PAIR) system. Status information for published applications may be obtained from either Private PAIR or Public PAIR. Status information for unpublished applications is available through Private PAIR only. For more information about the PAIR system, see <http://pair-direct.uspto.gov>. Should you have questions on access to the Private PAIR system, contact the Electronic Business Center (EBC) at 866-217-9197 (toll-free). If you would like assistance from a USPTO Customer Service Representative or access to the automated information system, call 800-786-9199 (IN USA OR CANADA) or 571-272-1000.

KCT

*/KHANH C TRAN/
Primary Examiner, Art Unit 2631*

Issue Classification 	Application/Control No. 13476310	Applicant(s)/Patent Under Reexamination KRINSKY ET AL.
	Examiner KHANH C TRAN	Art Unit 2631

ORIGINAL						INTERNATIONAL CLASSIFICATION												
CLASS		SUBCLASS				CLAIMED					NON-CLAIMED							
375		222				H	0	4	B	1 / 38 (2006.01.01)								
CROSS REFERENCE(S)						H	0	4	L	12 / 26 (2006.01.01)								
CLASS	SUBCLASS (ONE SUBCLASS PER BLOCK)																	
370	252																	

Claims renumbered in the same order as presented by applicant
 CPA
 T.D.
 R.1.47

Final	Original	Final	Original	Final	Original	Final	Original	Final	Original	Final	Original	Final	Original	Final	Original
-	1	-	17	-	33	6	49								
-	2	-	18	-	34	7	50								
-	3	-	19	-	35	8	51								
-	4	-	20	-	36	9	52								
-	5	-	21	-	37	10	53								
-	6	-	22	-	38										
-	7	-	23	-	39										
-	8	-	24	-	40										
-	9	-	25	-	41										
-	10	-	26	-	42										
-	11	-	27	-	43										
-	12	-	28	1	44										
-	13	-	29	2	45										
-	14	-	30	3	46										
-	15	-	31	4	47										
-	16	-	32	5	48										

NONE	Total Claims Allowed:	
(Assistant Examiner)	(Date)	10
/KHANH C TRAN/ Primary Examiner. Art Unit 2631	12/29/2012	O.G. Print Claim(s) 1
(Primary Examiner)	(Date)	O.G. Print Figure 1

<i>Index of Claims</i> 	Application/Control No. 13476310	Applicant(s)/Patent Under Reexamination KRINSKY ET AL.
	Examiner KHANH C TRAN	Art Unit 2631

✓	Rejected	-	Cancelled	N	Non-Elected	A	Appeal
=	Allowed	÷	Restricted	I	Interference	O	Objected

Claims renumbered in the same order as presented by applicant
 CPA
 T.D.
 R.1.47

CLAIM		DATE							
Final	Original	10/27/2012	12/29/2012						
	1	-	-						
	2	-	-						
	3	-	-						
	4	-	-						
	5	-	-						
	6	-	-						
	7	-	-						
	8	-	-						
	9	-	-						
	10	-	-						
	11	-	-						
	12	-	-						
	13	-	-						
	14	-	-						
	15	-	-						
	16	-	-						
	17	-	-						
	18	-	-						
	19	-	-						
	20	-	-						
	21	-	-						
	22	-	-						
	23	-	-						
	24	-	-						
	25	-	-						
	26	-	-						
	27	-	-						
	28	-	-						
	29	-	-						
	30	-	-						
	31	-	-						
	32	-	-						
	33	-	-						
	34	-	-						
	35	-	-						
	36	-	-						

<i>Index of Claims</i> 	Application/Control No. 13476310	Applicant(s)/Patent Under Reexamination KRINSKY ET AL.
	Examiner KHANH C TRAN	Art Unit 2631

✓	Rejected	-	Cancelled	N	Non-Elected	A	Appeal
=	Allowed	÷	Restricted	I	Interference	O	Objected

Claims renumbered in the same order as presented by applicant
 CPA
 T.D.
 R.1.47

CLAIM		DATE							
Final	Original	10/27/2012	12/29/2012						
	37	-	-						
	38	-	-						
	39	-	-						
	40	-	-						
	41	-	-						
	42	-	-						
	43	-	-						
1	44	✓	=						
2	45	✓	=						
3	46	✓	=						
4	47	✓	=						
5	48	✓	=						
6	49	✓	=						
7	50	✓	=						
8	51	✓	=						
9	52	✓	=						
10	53		=						



UNITED STATES PATENT AND TRADEMARK OFFICE

UNITED STATES DEPARTMENT OF COMMERCE
 United States Patent and Trademark Office
 Address: COMMISSIONER FOR PATENTS
 P.O. Box 1450
 Alexandria, Virginia 22313-1450
 www.uspto.gov

BIB DATA SHEET

CONFIRMATION NO. 7896

SERIAL NUMBER	FILING or 371(c) DATE	CLASS	GROUP ART UNIT	ATTORNEY DOCKET NO.		
13/476,310	05/21/2012	375	2631	6936-2-CON-2-1-4		
APPLICANTS David M. Krinsky, Acton, MA; Robert Edmund Pizzano JR., Stoneham, MA;						
** CONTINUING DATA ***** This application is a CON of 12/779,660 05/13/2010 PAT 8,238,412 YES which is a CON of 12/477,742 06/03/2009 PAT 7,835,430 YES which is a CON of 10/619,691 07/16/2003 PAT 7,570,686 YES which is a CON of 09/755,173 01/08/2001 PAT 6,658,052 YES which claims benefit of 60/224,308 08/10/2000 YES and claims benefit of 60/174,865 01/07/2000 YES						
** FOREIGN APPLICATIONS ***** /KCT/ /KCT/*****NO						
** IF REQUIRED, FOREIGN FILING LICENSE GRANTED *** SMALL ENTITY ** 05/31/2012						
Foreign Priority claimed <input type="checkbox"/> Yes <input checked="" type="checkbox"/> No 35 USC 119(a-d) conditions met <input type="checkbox"/> Yes <input type="checkbox"/> No Verified and Acknowledged /KXANH C TRAN/ Examiner's Signature		<input type="checkbox"/> Met after Allowance KCT Initials	STATE OR COUNTRY MA	SHEETS DRAWINGS 2	TOTAL CLAIMS 10	INDEPENDENT CLAIMS 5
ADDRESS Jason H. Vick Sheridan Ross, PC Suite # 1200 1560 Broadway Denver, CO 80202 UNITED STATES						
TITLE Multicarrier Modulation Messaging for Power Level Per Subchannel Information						
FILING FEE RECEIVED 1750	FEES: Authority has been given in Paper No. _____ to charge/credit DEPOSIT ACCOUNT No. _____ for following:			<input type="checkbox"/> All Fees <input type="checkbox"/> 1.16 Fees (Filing) <input type="checkbox"/> 1.17 Fees (Processing Ext. of time) <input type="checkbox"/> 1.18 Fees (Issue) <input type="checkbox"/> Other _____ <input type="checkbox"/> Credit		

Substitute for form 1449A/PTO				Complete if Known	
INFORMATION DISCLOSURE STATEMENT BY APPLICANT				Application Number	13/476310
				Filing Date	May 21, 2012
				First Named Inventor	David M. Krinsky et al.
				Art Unit	2631
				Examiner Name	TRAN, Khanh C.
Sheet	1	of	1	Attorney Docket Number	6936-2-CON-2-1-4

U.S. PATENT DOCUMENTS					
Examiner Initials*	Cite No. ¹	Document Number Number-kind Code ^{2 (if known)}	Publication Date MM-DD-YYYY	Name of Patentee of Applicant of Cited Document	Pages, Columns, Lines, Where Relevant Passages or Relevant Figures Appear
	1	3836726	09-17-1974	Wells et al.	
	2	5023873	06-11-1991	Stevens et al.	
	3	5313197	05-17-1994	Barr et al.	
	4	5388252	02-07-1995	Dreste et al.	

FOREIGN PATENT DOCUMENTS						
Examiner Initials*	Cite No. ¹	Foreign Patent Document Country Code ³ ; Number ⁴ ; Kind Code ^{5 (if known)}	Publication Date MM-DD-YYYY	Name of Patentee or Applicant of Cited Document	Pages, Columns, Lines, Where Relevant Passages or Relevant Figures Appear	T ⁶

OTHER ART (Including Author, Title, Date, Pertinent Pages, etc.)		
Examiner Initials*	Cite No. ¹	
	5	Official Action for U.S. Patent Application No. 13/004,254, mailed Dec. 4, 2012 (Attorney Ref. No.: 6936-2-CON-2-1-3)

Examiner Signature	/Khanh Tran/ (12/29/2012)	Date Considered	12/29/2012
--------------------	---------------------------	-----------------	------------

*EXAMINER: Initial if reference is considered, whether or not citation is in conformance and not considered. Include copy of this form with next communication to applicant.

ALL REFERENCES CONSIDERED EXCEPT WHERE LINED THROUGH. /KCT/

Search Notes 	Application/Control No. 13476310	Applicant(s)/Patent Under Reexamination KRINSKY ET AL.
	Examiner KHANH C TRAN	Art Unit 2631

SEARCHED			
Class	Subclass	Date	Examiner

SEARCH NOTES		
Search Notes	Date	Examiner
Update Searches on US Parent Cases 8,238,412 and 7,835,430	10/27/2012	KCT
Update Double Patenting Searches		KCT
Update Double Patenting Searches	12/29/2012	KCT

INTERFERENCE SEARCH			
Class	Subclass	Date	Examiner
All Classes previously cited	All Subclasses previously cited	12/29/2012	KCT

	/KHANH C TRAN/ Primary Examiner.Art Unit 2631
--	--

Substitute for form 1449A/PTO				Complete if Known	
INFORMATION DISCLOSURE STATEMENT BY APPLICANT				Application Number	13/476310
				Filing Date	May 21, 2012
				First Named Inventor	David M. Krinsky et al.
				Art Unit	2631
				Examiner Name	TRAN, Khanh C.
Sheet	1	of	1	Attorney Docket Number	6936-2-CON-2-1-4

U.S. PATENT DOCUMENTS					
Examiner Initials*	Cite No. ¹	Document Number Number-kind Code ^{2 (if known)}	Publication Date MM-DD-YYYY	Name of Patentee of Applicant of Cited Document	Pages, Columns, Lines, Where Relevant Passages or Relevant Figures Appear
	1	3836726	09-17-1974	Wells et al.	
	2	5023873	06-11-1991	Stevens et al.	
	3	5313197	05-17-1994	Barr et al.	
	4	5388252	02-07-1995	Dreste et al.	

FOREIGN PATENT DOCUMENTS						
Examiner Initials*	Cite No. ¹	Foreign Patent Document Country Code ³ ; Number ⁴ ; Kind Code ^{5 (if known)}	Publication Date MM-DD-YYYY	Name of Patentee or Applicant of Cited Document	Pages, Columns, Lines, Where Relevant Passages or Relevant Figures Appear	T ⁶

OTHER ART (Including Author, Title, Date, Pertinent Pages, etc.)		
Examiner Initials*	Cite No. ¹	
	5	Official Action for U.S. Patent Application No. 13/004,254, mailed Dec. 4, 2012 (Attorney Ref. No.: 6936-2-CON-2-1-3)

Examiner Signature		Date Considered	
--------------------	--	-----------------	--

*EXAMINER: Initial if reference is considered, whether or not citation is in conformance and not considered. Include copy of this form with next communication to applicant.

Electronic Acknowledgement Receipt

EFS ID:	14562421
Application Number:	13476310
International Application Number:	
Confirmation Number:	7896
Title of Invention:	Multicarrier Modulation Messaging for Power Level Per Subchannel Information
First Named Inventor/Applicant Name:	David M. Krinsky
Customer Number:	62574
Filer:	Jason Vick/Joanne Vos
Filer Authorized By:	Jason Vick
Attorney Docket Number:	6936-2-CON-2-1-4
Receipt Date:	26-DEC-2012
Filing Date:	21-MAY-2012
Time Stamp:	17:43:17
Application Type:	Utility under 35 USC 111(a)

Payment information:

Submitted with Payment	no
------------------------	----

File Listing:

Document Number	Document Description	File Name	File Size(Bytes)/ Message Digest	Multi Part /.zip	Pages (if appl.)
1		IDS_03.pdf	351463 98ca50162f2e3c32ba3cef31bf646c4d03aa ed0d	yes	4

Multipart Description/PDF files in .zip description					
Document Description			Start	End	
Transmittal Letter			1	3	
Information Disclosure Statement (IDS) Form (SB08)			4	4	
Warnings:					
Information:					
2	Non Patent Literature	6936-2- CON-2-1-3_OA_12-04-2012.pdf	9276019	no	12
			f1478580b86344be9566fa4ea1f7ac7a4186 930a		
Warnings:					
Information:					
Total Files Size (in bytes):			9627482		
<p>This Acknowledgement Receipt evidences receipt on the noted date by the USPTO of the indicated documents, characterized by the applicant, and including page counts, where applicable. It serves as evidence of receipt similar to a Post Card, as described in MPEP 503.</p> <p><u>New Applications Under 35 U.S.C. 111</u> If a new application is being filed and the application includes the necessary components for a filing date (see 37 CFR 1.53(b)-(d) and MPEP 506), a Filing Receipt (37 CFR 1.54) will be issued in due course and the date shown on this Acknowledgement Receipt will establish the filing date of the application.</p> <p><u>National Stage of an International Application under 35 U.S.C. 371</u> If a timely submission to enter the national stage of an international application is compliant with the conditions of 35 U.S.C. 371 and other applicable requirements a Form PCT/DO/EO/903 indicating acceptance of the application as a national stage submission under 35 U.S.C. 371 will be issued in addition to the Filing Receipt, in due course.</p> <p><u>New International Application Filed with the USPTO as a Receiving Office</u> If a new international application is being filed and the international application includes the necessary components for an international filing date (see PCT Article 11 and MPEP 1810), a Notification of the International Application Number and of the International Filing Date (Form PCT/RO/105) will be issued in due course, subject to prescriptions concerning national security, and the date shown on this Acknowledgement Receipt will establish the international filing date of the application.</p>					

IN THE UNITED STATES PATENT AND TRADEMARK OFFICE

In Re the Application of:)	Group Art Unit: 2631
David M. Krinsky et al.)	Confirmation No.: 7896
Serial No.: 13/476,310)	Examiner: TRAN, Khanh C.
Filed: May 21, 2012)	
Atty. File No.: 6936-2-CON-2-1-4)	<u>SUPPLEMENTAL</u>
Entitled: "MULTICARRIER MODULATION)	<u>INFORMATION DISCLOSURE</u>
MESSAGING FOR POWER LEVEL PER)	<u>STATEMENT</u>
SUBCHANNEL INFORMATION")	Electronically Submitted

Commissioner for Patents
P.O. Box 1450
Alexandria, VA 22313-1450

Dear Sir:

The references cited on attached Form PTO-1449 are being called to the attention of the Examiner.

- Copies of the cited non-patent and/or foreign references are enclosed herewith.
- Copies of the cited U.S. patents and/or patent applications are enclosed herewith.
- Copies of the cited U.S. patents/patent application publications are not enclosed in accordance with 37 C.F.R. § 1.98(a).
- Copies of the cited references are not enclosed, in accordance with 37 C.F.R. § 1.98(d), because the references were cited by or submitted to the U.S. Patent and Trademark Office in prior application Serial No. _____ filed _____, which is relied upon for an earlier filing date under 35 U.S.C. § 120.
- To the best of applicants' belief, the pertinence of the foreign-language references are believed to be summarized in the attached English translation/abstracts and/or in the figures, although applicants do not necessarily vouch for the accuracy of the translation.
- Examiner's attention is drawn to the following related applications:
 - Serial No. _____ filed _____, (Attorney's Ref. No. _____)
- Other: _____

Submission of the above information is not intended as an admission that any item is citable under the statutes or rules to support a rejection, that any item disclosed represents analogous art, or that those skilled in the art would refer to or recognize the pertinence of any reference without the benefit of hindsight, nor should an inference be drawn as to the pertinence of the references based on the order in which they are presented.

Submission of this statement should not be taken as an indication that a search has been conducted, or that no better art exists.

It is respectfully requested that the cited information be expressly considered during the prosecution of this application and the references made of record therein.

FEES

<input type="checkbox"/>	<p>37 CFR 1.97(b): No fee is believed due in connection with this submission, because the information disclosure statement submitted herewith is satisfied by one of the following conditions ("X" indicates satisfaction):</p> <p><input type="checkbox"/> Within three months of the filing date of a national application other than a continued prosecution application under 37 CFR 1.53(d), or</p> <p><input type="checkbox"/> Within three months of the date of entry into the national stage of an international application as set forth in 37 CFR 1.491 or</p> <p><input type="checkbox"/> Before the mailing date of a first Office Action on the merits, or</p> <p><input type="checkbox"/> Before the mailing of a first Office action after the filing of a request for continued examination under 37 CFR 1.114.</p> <p>Although no fee is believed due, if any fee is deemed due in connection with this submission, please charge such fee to Deposit Account 19-1970.</p>
<input checked="" type="checkbox"/>	<p>37 CFR 1.97(c): The information disclosure statement transmitted herewith is being filed after all the above conditions (37 CFR 1.97(b)), but before the mailing date of one of the following conditions:</p> <p>(1) a final action under 37 C.F.R. 1.113 or</p> <p>(2) a notice of allowance under 37 C.F.R. 1.311, or</p> <p>(3) an action that otherwise closes prosecution in the application.</p> <p>This Information Disclosure Statement is accompanied by:</p> <p><input checked="" type="checkbox"/> A Certification (below) as specified by 37 C.F.R. 1.97(e). Although no fee is believed due, if any fee is deemed due in connection with this submission, please charge such fee to Deposit Account 19-1970.</p> <p style="text-align: center;">OR</p> <p><input type="checkbox"/> Please charge Deposit Account 19-1970 in the amount of \$180.00 for the fee set forth in 37 C.F.R. 1.17(p) for submission of an information disclosure statement. Please credit any overpayment or charge any underpayment to Deposit Account 19-1970.</p>
<input type="checkbox"/>	<p>37 CFR 1.97(d): This Information Disclosure Statement is being submitted after the period specified in 37 CFR 1.97(c).</p> <p><input type="checkbox"/> This information Disclosure Statement includes a Certification (below) as specified by 37 C.F.R. 1.97(e)</p> <p style="text-align: center;">AND</p> <p><input type="checkbox"/> Applicants hereby requests consideration of the reference(s) disclosed herein. Please charge Deposit Account 19-1970 in the amount of \$180.00 under 37 C.F.R. 1.17(p). Please credit any overpayment or charge any underpayment to Deposit Account 19-1970. Election to pay the fee should not be taken as an indication that applicant(s) cannot execute a certification.</p>

Certification (37 C.F.R. 1.97(e))
(Applicable only if checked)

- The undersigned certifies that:
- Each item of information contained in this information disclosure statement was first cited in any communication from a foreign patent office in a counterpart foreign application not more than three months prior to the filing of this statement. 37 C.F.R. 1.97(e)(1).
 - A copy of the communication from the foreign patent office is enclosed.

OR

- No item of information contained in this information disclosure statement was cited in a communication from a foreign patent office in a counterpart foreign application, and, to the knowledge of the undersigned after making reasonable inquiry, no item of information contained in this Information Disclosure Statement was known to any individual designated in 37 C.F.R. 1.56(c) more than three months prior to the filing of this statement. 37 C.F.R. 1.97(e)(2).

Respectfully submitted,

SHERIDAN ROSS P.C.

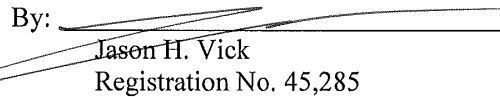
By: 
Jason H. Vick
Registration No. 45,285
1560 Broadway, Suite 1200
Denver, Colorado 80202-5141
(303) 863-9700

Date: 26 Dec '13

IN THE UNITED STATES PATENT AND TRADEMARK OFFICE

In Re the Application of: David M. Krinsky) Group Art Unit: 2631
Application No.: 13/476,310) Examiner: TRAN, Khanh C.
Filed: May 21, 2012) Confirmation No.: 7896
Atty. File No.: 6936-2-CON-2-1-4)

For: MULTICARRIER MODULATION MESSAGING FOR POWER LEVEL PER
SUBCHANNEL INFORMATION

AMENDMENT AND RESPONSE AND
RESPONSE TO NON-COMPLIANT AMENDMENT

Commissioner for Patents
P.O. Box 1450
Alexandria, VA 22313-1450

Madam:

Applicants submit this Amendment and Response to address the Office Action having a mailing date of November 5, 2012 and further to address the Notice of Non-Compliant Amendment mailed November 27, 2012. Please credit any overpayment or charge any underpayment to Deposit Account No. 19-1970.

Please amend the above-identified patent application as follows:

Amendments to the Claims are shown in the listing of claims which begins on page 2 of this paper.

Remarks begin on page 5 of this paper.

Amendments to the Claims:

This listing of claims will replace all prior versions, and listings, of claims in the application:

Listing of Claims:

1-43. (Cancelled)

44. (Previously Presented) A transceiver capable of transmitting diagnostic information over a communication channel using multicarrier modulation comprising:
a transmitter portion capable of transmitting a message, wherein the message comprises one or more data variables that represent the diagnostic information, wherein bits in the message are modulated onto DMT symbols using Quadrature Amplitude Modulation (QAM) with more than 1 bit per subchannel and wherein at least one data variable of the one or more data variables comprises an array representing power level per subchannel information.

45. (Previously Presented) The transceiver of claim 44, wherein the power level per subchannel information is based on a Reverb signal.

46. (Previously Presented) A transceiver capable of receiving diagnostic information over a communication channel using multicarrier modulation comprising:
a receiver portion capable of receiving a message, wherein the message comprises one or more data variables that represent the diagnostic information, wherein bits in the message were modulated onto DMT symbols using Quadrature Amplitude Modulation (QAM) with more than 1 bit per subchannel and wherein at least one data variable of the one or more data variables comprises an array representing power level per subchannel information.

47. (Previously Presented) The transceiver of claim 46, wherein the power level per subchannel information is based on a Reverb signal.

48. (Previously Presented) In a transceiver capable of transmitting diagnostic information over a communication channel using multicarrier modulation, a method comprising:

transmitting a message, wherein the message comprises one or more data variables that represent the diagnostic information, wherein bits in the message are modulated onto DMT symbols using Quadrature Amplitude Modulation (QAM) with more than 1 bit per subchannel and wherein at least one data variable of the one or more data variables comprises an array representing power level per subchannel information.

49. (Previously Presented) The method of claim 48, wherein the power level per subchannel information is based on a Reverb signal.

50. (Previously Presented) In a transceiver capable of receiving diagnostic information over a communication channel using multicarrier modulation, a method comprising:
receiving a message, wherein the message comprises one or more data variables that represent the diagnostic information, wherein bits in the message were modulated onto DMT symbols using Quadrature Amplitude Modulation (QAM) with more than 1 bit per subchannel and wherein at least one data variable of the one or more data variables comprises an array representing power level per subchannel information.

51. (Previously Presented) The method of claim 50, wherein the power level per subchannel information is based on a Reverb signal.

52. (Previously Presented) A communications system for DSL service comprising a first DSL transceiver capable of transmitting diagnostic information over a communication channel using multicarrier modulation and a second DSL transceiver capable of receiving the diagnostic information over the communication channel using multicarrier modulation comprising:

a transmitter portion of the first transceiver capable of transmitting a message, wherein the message comprises one or more data variables that represent the diagnostic information, wherein bits in the message are modulated onto DMT symbols using Quadrature Amplitude Modulation (QAM) with more than 1 bit per subchannel and wherein at least one data variable of the one or more data variables comprises an array representing Signal to Noise ratio per subchannel during Showtime information; and

a receiver portion of the second transceiver capable of receiving the message, wherein the message comprises the one or more data variables that represent the diagnostic information, wherein the bits in the message were modulated onto the DMT symbols using Quadrature Amplitude Modulation (QAM) with more than 1 bit per subchannel and wherein the at least one data variable of the one or more data variables comprises the array representing Signal to Noise ratio per subchannel during Showtime information.

53. (New) The system of claim 52, wherein the DSL service is for internet access.

REMARKS

Applicant requests reconsideration of this application as amended and based on the accompanying Terminal Disclaimer.

Claims 44-53 are pending.

By this amendment, new dependent claim 53 has been added.

Ex. Tran is expressly thanked for the indication that claims 44-52 would be allowed if the requested Terminal Disclaimers are filed.

Accompanying this response are Terminal Disclaimers for U.S. Patent No. 8,238,412, U.S. Patent No. 7,835,430, and U.S. Patent No. 7,889,784, which therefore renders the double patenting rejections moot.

With all rejections having been overcome, Applicant respectfully submits the application is in condition for allowance. A prompt Notice of Allowance is respectfully solicited.

Should the Examiner believe anything further is desirable in order to place the application in even better condition for allowance, the Examiner is encouraged to contact Applicants undersigned representative at the telephone number listed below.

The Commissioner is hereby authorized to charge to deposit account number 19-1970 any fees under 37 CFR § 1.16 and 1.17 that may be required by this paper and to credit any overpayment to that Account. If any extension of time is required in connection with the filing of this paper and has not been separately requested, such extension is hereby Petitioned.

Respectfully submitted,

SHERIDAN ROSS P.C.

Date: 2 Dec '12

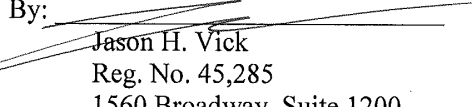
By: 
Jason H. Vick
Reg. No. 45,285
1560 Broadway, Suite 1200
Denver, Colorado 80202
Telephone: 303-863-9700

Electronic Acknowledgement Receipt

EFS ID:	14370054
Application Number:	13476310
International Application Number:	
Confirmation Number:	7896
Title of Invention:	Multicarrier Modulation Messaging for Power Level Per Subchannel Information
First Named Inventor/Applicant Name:	David M. Krinsky
Customer Number:	62574
Filer:	Jason Vick/Joanne Vos
Filer Authorized By:	Jason Vick
Attorney Docket Number:	6936-2-CON-2-1-4
Receipt Date:	03-DEC-2012
Filing Date:	21-MAY-2012
Time Stamp:	16:53:37
Application Type:	Utility under 35 USC 111(a)

Payment information:

Submitted with Payment	no
------------------------	----

File Listing:

Document Number	Document Description	File Name	File Size(Bytes)/ Message Digest	Multi Part /.zip	Pages (if appl.)
1		AMEND_02_response_to_Non-Compliance.pdf	399017 995b9a3fa7330ed7c05feb1aad8af7e2d5d57a5	yes	5

Multipart Description/PDF files in .zip description		
Document Description	Start	End
Supplemental Response or Supplemental Amendment	1	1
Claims	2	4
Applicant Arguments/Remarks Made in an Amendment	5	5

Warnings:

Information:

Total Files Size (in bytes):	399017
-------------------------------------	--------

This Acknowledgement Receipt evidences receipt on the noted date by the USPTO of the indicated documents, characterized by the applicant, and including page counts, where applicable. It serves as evidence of receipt similar to a Post Card, as described in MPEP 503.

New Applications Under 35 U.S.C. 111

If a new application is being filed and the application includes the necessary components for a filing date (see 37 CFR 1.53(b)-(d) and MPEP 506), a Filing Receipt (37 CFR 1.54) will be issued in due course and the date shown on this Acknowledgement Receipt will establish the filing date of the application.

National Stage of an International Application under 35 U.S.C. 371

If a timely submission to enter the national stage of an international application is compliant with the conditions of 35 U.S.C. 371 and other applicable requirements a Form PCT/DO/EO/903 indicating acceptance of the application as a national stage submission under 35 U.S.C. 371 will be issued in addition to the Filing Receipt, in due course.

New International Application Filed with the USPTO as a Receiving Office

If a new international application is being filed and the international application includes the necessary components for an international filing date (see PCT Article 11 and MPEP 1810), a Notification of the International Application Number and of the International Filing Date (Form PCT/RO/105) will be issued in due course, subject to prescriptions concerning national security, and the date shown on this Acknowledgement Receipt will establish the international filing date of the application.



UNITED STATES PATENT AND TRADEMARK OFFICE

UNITED STATES DEPARTMENT OF COMMERCE
U.S. Patent and Trademark Office
Address: COMMISSIONER FOR PATENTS
P.O. Box 1450
Alexandria, Virginia 22313-1450
www.uspto.gov

62574 e 2012-11-27

Jason H. Vick
Sheridan Ross, PC
Suite # 1200
1560 Broadway
Denver, CO 80202

Paper No.

Application No.:	13/476,310	Date Mailed:	2012-11-27
			
First Named Inventor:	Krinsky, David, M.	Examiner:	TRAN, KHANH C
Attorney Docket No.:	6936-2-CON-2-1-4	Art Unit:	2631
Confirmation No.:	7896	Filing Date:	2012-05-21

Please find attached an Office communication concerning this application or proceeding.

Commissioner for Patents

Notice of Non-Compliant Amendment (37 CFR 1.121)	Application No. 13/476,310	Applicant(s) KRINSKY ET AL.
		Art Unit 2800

-- The MAILING DATE of this communication appears on the cover sheet with the correspondence address --

The amendment document filed on 19 November, 2012 is considered non-compliant because it has failed to meet the requirements of 37 CFR 1.121 or 1.4. In order for the amendment document to be compliant, correction of the following item(s) is required.

THE FOLLOWING MARKED (X) ITEM(S) CAUSE THE AMENDMENT DOCUMENT TO BE NON-COMPLIANT:

- 1. Amendments to the specification:
 - A. Amended paragraph(s) do not include markings.
 - B. New paragraph(s) should not be underlined.
 - C. Other _____.
- 2. Abstract:
 - A. Not presented on a separate sheet. 37 CFR 1.72.
 - B. Other _____.
- 3. Amendments to the drawings:
 - A. The drawings are not properly identified in the top margin as "Replacement Sheet," "New Sheet," or "Annotated Sheet" as required by 37 CFR 1.121(d).
 - B. The practice of submitting proposed drawing correction has been eliminated. Replacement drawings showing amended figures, without markings, in compliance with 37 CFR 1.84 are required.
 - C. Other _____.
- 4. Amendments to the claims:
 - A. A complete listing of all of the claims is not present.
 - B. The listing of claims does not include the text of all pending claims (including withdrawn claims)
 - C. Each claim has not been provided with the proper status identifier, and as such, the individual status of each claim cannot be identified. Note: the status of every claim must be indicated after its claim number by using one of the following status identifiers: (Original), (Currently amended), (Canceled), (Previously presented), (New), (Not entered), (Withdrawn) and (Withdrawn-currently amended).
 - D. The claims of this amendment paper have not been presented in ascending numerical order.
 - E. Other: _____.
- 5. Other (e.g., the amendment is unsigned or not signed in accordance with 37 CFR 1.4): For further explanation of the amendment format required by 37 CFR 1.121, see MPEP § 714.

TIME PERIODS FOR FILING A REPLY TO THIS NOTICE:

1. Applicant is given **no new time period if the non-compliant amendment is an** after-final amendment or an amendment filed after allowance, or a drawing submission (only) If applicant wishes to resubmit the non-compliant after-final amendment with corrections, the **entire corrected amendment** must be resubmitted.
2. Applicant is given **one month**, or thirty (30) days, whichever is longer, from the mail date of this notice to supply the correction, if the non-compliant amendment is one of the following: a preliminary amendment, a non-final amendment (including a submission for a request for continued examination (RCE) under 37 CFR 1.114), a supplemental amendment filed within a suspension period under 37 CFR 1.103(a) or (c), and an amendment filed in response to a Quayle action. If any of above boxes 1 to 4 are checked, the correction required is only the corrected section of the non-compliant amendment in compliance with 37 CFR 1.121.

Extensions of time are available under 37 CFR 1.136(a) only if the non-compliant amendment is a non-final amendment or an amendment filed in response to a *Quayle* action.

Failure to timely respond to this notice will result in:

Abandonment of the application if the non-compliant amendment is a non-final amendment or an amendment filed in response to a *Quayle* action; or

Non-entry of the amendment if the non-compliant amendment is a preliminary amendment or supplemental amendment.

Legal Instruments Examiner (LIE), if applicable /PAULA BRITTON/

Telephone No: (571)272-1556

Doc Code: DIST.E.FILE Document Description: Electronic Terminal Disclaimer - Filed		PTO/SB/26 U.S. Patent and Trademark Office Department of Commerce
Electronic Petition Request	TERMINAL DISCLAIMER TO OBTAIN A DOUBLE PATENTING REJECTION OVER A "PRIOR" PATENT	
Application Number	13476310	
Filing Date	21-May-2012	
First Named Inventor	David Krinsky	
Attorney Docket Number	6936-2-CON-2-1-4	
Title of Invention	Multicarrier Modulation Messaging for Power Level Per Subchannel Information	
<input checked="" type="checkbox"/> Filing of terminal disclaimer does not obviate requirement for response under 37 CFR 1.111 to outstanding Office Action <input checked="" type="checkbox"/> This electronic Terminal Disclaimer is not being used for a Joint Research Agreement.		
Owner	Percent Interest	
TQ DELTA, LLC	100%	
<p>The owner(s) with percent interest listed above in the instant application hereby disclaims, except as provided below, the terminal part of the statutory term of any patent granted on the instant application which would extend beyond the expiration date of the full statutory term of prior patent number(s)</p> <p>8238412 7835430 7889784</p> <p>as the term of said prior patent is presently shortened by any terminal disclaimer. The owner hereby agrees that any patent so granted on the instant application shall be enforceable only for and during such period that it and the prior patent are commonly owned. This agreement runs with any patent granted on the instant application and is binding upon the grantee, its successors or assigns.</p> <p>In making the above disclaimer, the owner does not disclaim the terminal part of the term of any patent granted on the instant application that would extend to the expiration date of the full statutory term of the prior patent, "as the term of said prior patent is presently shortened by any terminal disclaimer," in the event that said prior patent later:</p> <ul style="list-style-type: none"> - expires for failure to pay a maintenance fee; - is held unenforceable; - is found invalid by a court of competent jurisdiction; - is statutorily disclaimed in whole or terminally disclaimed under 37 CFR 1.321; - has all claims canceled by a reexamination certificate; - is reissued; or - is in any manner terminated prior to the expiration of its full statutory term as presently shortened by any terminal disclaimer. 		

- Terminal disclaimer fee under 37 CFR 1.20(d) is included with Electronic Terminal Disclaimer request.
- I certify, in accordance with 37 CFR 1.4(d)(4), that the terminal disclaimer fee under 37 CFR 1.20(d) required for this terminal disclaimer has already been paid in the above-identified application.

- Applicant claims SMALL ENTITY status. See 37 CFR 1.27.
- Applicant is no longer claiming SMALL ENTITY status. See 37 CFR 1.27(g)(2).
- Applicant(s) status remains as SMALL ENTITY.
- Applicant(s) status remains as other than SMALL ENTITY.

I hereby declare that all statements made herein of my own knowledge are true and that all statements made on information and belief are believed to be true; and further that these statements were made with the knowledge that willful false statements and the like so made are punishable by fine or imprisonment, or both, under Section 1001 of Title 18 of the United States Code and that such willful false statements may jeopardize the validity of the application or any patent issued thereon.

THIS PORTION MUST BE COMPLETED BY THE SIGNATORY OR SIGNATORIES

I certify, in accordance with 37 CFR 1.4(d)(4) that I am:

- An attorney or agent registered to practice before the Patent and Trademark Office who is of record in this application
 Registration Number 45285
- A sole inventor
- A joint inventor; I certify that I am authorized to sign this submission on behalf of all of the inventors
- A joint inventor; all of whom are signing this request
- The assignee of record of the entire interest that has properly made itself of record pursuant to 37 [CFR 3.71](#)

Signature	/Jason H. Vick/
Name	Jason H. Vick

*Statement under 37 CFR 3.73(b) is required if terminal disclaimer is signed by the assignee (owner).
 Form PTO/SB/96 may be used for making this certification. See MPEP § 324.

Electronic Patent Application Fee Transmittal

Application Number:	13476310			
Filing Date:	21-May-2012			
Title of Invention:	Multicarrier Modulation Messaging for Power Level Per Subchannel Information			
First Named Inventor/Applicant Name:	David M. Krinsky			
Filer:	Jason Vick/Joanne Vos			
Attorney Docket Number:	6936-2-CON-2-1-4			
Filed as Small Entity				
Utility under 35 USC 111(a) Filing Fees				
Description	Fee Code	Quantity	Amount	Sub-Total in USD(\$)
Basic Filing:				
Statutory or terminal disclaimer	2814	1	80	80
Pages:				
Claims:				
Miscellaneous-Filing:				
Petition:				
Patent-Appeals-and-Interference:				
Post-Allowance-and-Post-Issuance:				
Extension-of-Time:				

Description	Fee Code	Quantity	Amount	Sub-Total in USD(\$)
Miscellaneous:				
Total in USD (\$)				80

Doc Code: DISQ.E.FILE
Document Description: Electronic Terminal Disclaimer – Approved

Application No.: 13476310

Filing Date: 21-May-2012

Applicant/Patent under Reexamination: Krinsky et al.

Electronic Terminal Disclaimer filed on November 19, 2012

APPROVED

This patent is subject to a terminal disclaimer

DISAPPROVED

Approved/Disapproved by: Electronic Terminal Disclaimer automatically approved by EFS-Web

U.S. Patent and Trademark Office

Electronic Acknowledgement Receipt

EFS ID:	14263072
Application Number:	13476310
International Application Number:	
Confirmation Number:	7896
Title of Invention:	Multicarrier Modulation Messaging for Power Level Per Subchannel Information
First Named Inventor/Applicant Name:	David M. Krinsky
Customer Number:	62574
Filer:	Jason Vick/Joanne Vos
Filer Authorized By:	Jason Vick
Attorney Docket Number:	6936-2-CON-2-1-4
Receipt Date:	19-NOV-2012
Filing Date:	21-MAY-2012
Time Stamp:	14:34:18
Application Type:	Utility under 35 USC 111(a)

Payment information:

Submitted with Payment	yes
Payment Type	Deposit Account
Payment was successfully received in RAM	\$80
RAM confirmation Number	1062
Deposit Account	191970
Authorized User	
<p>The Director of the USPTO is hereby authorized to charge indicated fees and credit any overpayment as follows:</p> <p style="padding-left: 40px;">Charge any Additional Fees required under 37 C.F.R. Section 1.16 (National application filing, search, and examination fees)</p> <p style="padding-left: 40px;">Charge any Additional Fees required under 37 C.F.R. Section 1.17 (Patent application and reexamination processing fees)</p>	

Charge any Additional Fees required under 37 C.F.R. Section 1.19 (Document supply fees)

Charge any Additional Fees required under 37 C.F.R. Section 1.21 (Miscellaneous fees and charges)

File Listing:

Document Number	Document Description	File Name	File Size(Bytes)/ Message Digest	Multi Part /.zip	Pages (if appl.)
1	Electronic Terminal Disclaimer-Filed	eTerminal-Disclaimer.pdf	33865 aecb5e00548e49fca81474420a52764bdb589430	no	2

Warnings:

Information:

2	Fee Worksheet (SB06)	fee-info.pdf	30178 f329bc1b27ca26b962dfb4e6f0db77b99fe9e5c	no	2
---	----------------------	--------------	--	----	---

Warnings:

Information:

Total Files Size (in bytes):	64043
-------------------------------------	-------

This Acknowledgement Receipt evidences receipt on the noted date by the USPTO of the indicated documents, characterized by the applicant, and including page counts, where applicable. It serves as evidence of receipt similar to a Post Card, as described in MPEP 503.

New Applications Under 35 U.S.C. 111

If a new application is being filed and the application includes the necessary components for a filing date (see 37 CFR 1.53(b)-(d) and MPEP 506), a Filing Receipt (37 CFR 1.54) will be issued in due course and the date shown on this Acknowledgement Receipt will establish the filing date of the application.

National Stage of an International Application under 35 U.S.C. 371

If a timely submission to enter the national stage of an international application is compliant with the conditions of 35 U.S.C. 371 and other applicable requirements a Form PCT/DO/EO/903 indicating acceptance of the application as a national stage submission under 35 U.S.C. 371 will be issued in addition to the Filing Receipt, in due course.

New International Application Filed with the USPTO as a Receiving Office

If a new international application is being filed and the international application includes the necessary components for an international filing date (see PCT Article 11 and MPEP 1810), a Notification of the International Application Number and of the International Filing Date (Form PCT/RO/105) will be issued in due course, subject to prescriptions concerning national security, and the date shown on this Acknowledgement Receipt will establish the international filing date of the application.

IN THE UNITED STATES PATENT AND TRADEMARK OFFICE

In Re the Application of: David M. Krinsky)	Group Art Unit: 2631
)	
Application No.: 13/476,310)	Examiner: TRAN, Khanh C.
)	
Filed: May 21, 2012)	Confirmation No.: 7896
)	
Atty. File No.: 6936-2-CON-2-1-4)	
)	

For: MULTICARRIER MODULATION MESSAGING FOR POWER LEVEL PER
SUBCHANNEL INFORMATION

AMENDMENT AND RESPONSE

Commissioner for Patents
P.O. Box 1450
Alexandria, VA 22313-1450

Madam:

Applicants submit this Amendment and Response to address the Office Action having a mailing date of November 5, 2012. Please credit any overpayment or charge any underpayment to Deposit Account No. 19-1970.

Please amend the above-identified patent application as follows:

Amendments to the Claims are shown in the listing of claims which begins on page 2 of this paper.

Remarks begin on page 5 of this paper.

Amendments to the Claims:

This listing of claims will replace all prior versions, and listings, of claims in the application:

Listing of Claims:

44. (Previously Presented) A transceiver capable of transmitting diagnostic information over a communication channel using multicarrier modulation comprising:

a transmitter portion capable of transmitting a message, wherein the message comprises one or more data variables that represent the diagnostic information, wherein bits in the message are modulated onto DMT symbols using Quadrature Amplitude Modulation (QAM) with more than 1 bit per subchannel and wherein at least one data variable of the one or more data variables comprises an array representing power level per subchannel information.

45. (Previously Presented) The transceiver of claim 44, wherein the power level per subchannel information is based on a Reverb signal.

46. (Previously Presented) A transceiver capable of receiving diagnostic information over a communication channel using multicarrier modulation comprising:

a receiver portion capable of receiving a message, wherein the message comprises one or more data variables that represent the diagnostic information, wherein bits in the message were modulated onto DMT symbols using Quadrature Amplitude Modulation (QAM) with more than 1 bit per subchannel and wherein at least one data variable of the one or more data variables comprises an array representing power level per subchannel information.

47. (Previously Presented) The transceiver of claim 46, wherein the power level per subchannel information is based on a Reverb signal.

48. (Previously Presented) In a transceiver capable of transmitting diagnostic information over a communication channel using multicarrier modulation, a method comprising:

transmitting a message, wherein the message comprises one or more data variables that represent the diagnostic information, wherein bits in the message are modulated onto DMT

symbols using Quadrature Amplitude Modulation (QAM) with more than 1 bit per subchannel and wherein at least one data variable of the one or more data variables comprises an array representing power level per subchannel information.

49. (Previously Presented) The method of claim 48, wherein the power level per subchannel information is based on a Reverb signal.

50. (Previously Presented) In a transceiver capable of receiving diagnostic information over a communication channel using multicarrier modulation, a method comprising:
receiving a message, wherein the message comprises one or more data variables that represent the diagnostic information, wherein bits in the message were modulated onto DMT symbols using Quadrature Amplitude Modulation (QAM) with more than 1 bit per subchannel and wherein at least one data variable of the one or more data variables comprises an array representing power level per subchannel information.

51. (Previously Presented) The method of claim 50, wherein the power level per subchannel information is based on a Reverb signal.

52. (Previously Presented) A communications system for DSL service comprising a first DSL transceiver capable of transmitting diagnostic information over a communication channel using multicarrier modulation and a second DSL transceiver capable of receiving the diagnostic information over the communication channel using multicarrier modulation comprising:

a transmitter portion of the first transceiver capable of transmitting a message, wherein the message comprises one or more data variables that represent the diagnostic information, wherein bits in the message are modulated onto DMT symbols using Quadrature Amplitude Modulation (QAM) with more than 1 bit per subchannel and wherein at least one data variable of the one or more data variables comprises an array representing Signal to Noise ratio per subchannel during Showtime information; and

a receiver portion of the second transceiver capable of receiving the message, wherein the message comprises the one or more data variables that represent the diagnostic information,

wherein the bits in the message were modulated onto the DMT symbols using Quadrature Amplitude Modulation (QAM) with more than 1 bit per subchannel and wherein the at least one data variable of the one or more data variables comprises the array representing Signal to Noise ratio per subchannel during Showtime information.

53. (New) The system of claim 52, wherein the DSL service is for internet access.

REMARKS

Applicant requests reconsideration of this application as amended and based on the accompanying Terminal Disclaimer.

Claims 44-53 are pending.

By this amendment, new dependent claim 53 has been added.

Ex. Tran is expressly thanked for the indication that claims 44-52 would be allowed if the requested Terminal Disclaimers are filed.

Accompanying this response are Terminal Disclaimers for U.S. Patent No. 8,238,412, U.S. Patent No. 7,835,430, and U.S. Patent No. 7,889,784, which therefore renders the double patenting rejections moot.

With all rejections having been overcome, Applicant respectfully submits the application is in condition for allowance. A prompt Notice of Allowance is respectfully solicited.

Should the Examiner believe anything further is desirable in order to place the application in even better condition for allowance, the Examiner is encouraged to contact Applicants undersigned representative at the telephone number listed below.

The Commissioner is hereby authorized to charge to deposit account number 19-1970 any fees under 37 CFR § 1.16 and 1.17 that may be required by this paper and to credit any overpayment to that Account. If any extension of time is required in connection with the filing of this paper and has not been separately requested, such extension is hereby Petitioned.

Respectfully submitted,

SHERIDAN ROSS P.C.

Date: 19 Nov '12

By: _____

Jason H. Vick
Reg. No. 45,285
1560 Broadway, Suite 1200
Denver, Colorado 80202
Telephone: 303-863-9700

Electronic Acknowledgement Receipt

EFS ID:	14263241
Application Number:	13476310
International Application Number:	
Confirmation Number:	7896
Title of Invention:	Multicarrier Modulation Messaging for Power Level Per Subchannel Information
First Named Inventor/Applicant Name:	David M. Krinsky
Customer Number:	62574
Filer:	Jason Vick/Joanne Vos
Filer Authorized By:	Jason Vick
Attorney Docket Number:	6936-2-CON-2-1-4
Receipt Date:	19-NOV-2012
Filing Date:	21-MAY-2012
Time Stamp:	14:36:22
Application Type:	Utility under 35 USC 111(a)

Payment information:

Submitted with Payment	no
------------------------	----

File Listing:

Document Number	Document Description	File Name	File Size(Bytes)/ Message Digest	Multi Part /.zip	Pages (if appl.)
1		AMEND_01.pdf	388485 1a6a1d552482c8f4276f260881d22983677 23433	yes	5

Multipart Description/PDF files in .zip description		
Document Description	Start	End
Amendment/Req. Reconsideration-After Non-Final Reject	1	1
Claims	2	4
Applicant Arguments/Remarks Made in an Amendment	5	5
Warnings:		
Information:		
Total Files Size (in bytes):	388485	
<p>This Acknowledgement Receipt evidences receipt on the noted date by the USPTO of the indicated documents, characterized by the applicant, and including page counts, where applicable. It serves as evidence of receipt similar to a Post Card, as described in MPEP 503.</p> <p><u>New Applications Under 35 U.S.C. 111</u> If a new application is being filed and the application includes the necessary components for a filing date (see 37 CFR 1.53(b)-(d) and MPEP 506), a Filing Receipt (37 CFR 1.54) will be issued in due course and the date shown on this Acknowledgement Receipt will establish the filing date of the application.</p> <p><u>National Stage of an International Application under 35 U.S.C. 371</u> If a timely submission to enter the national stage of an international application is compliant with the conditions of 35 U.S.C. 371 and other applicable requirements a Form PCT/DO/EO/903 indicating acceptance of the application as a national stage submission under 35 U.S.C. 371 will be issued in addition to the Filing Receipt, in due course.</p> <p><u>New International Application Filed with the USPTO as a Receiving Office</u> If a new international application is being filed and the international application includes the necessary components for an international filing date (see PCT Article 11 and MPEP 1810), a Notification of the International Application Number and of the International Filing Date (Form PCT/RO/105) will be issued in due course, subject to prescriptions concerning national security, and the date shown on this Acknowledgement Receipt will establish the international filing date of the application.</p>		



UNITED STATES PATENT AND TRADEMARK OFFICE

UNITED STATES DEPARTMENT OF COMMERCE
United States Patent and Trademark Office
Address: COMMISSIONER FOR PATENTS
P.O. Box 1450
Alexandria, Virginia 22313-1450
www.uspto.gov

APPLICATION NUMBER	FILING OR 371(C) DATE	FIRST NAMED APPLICANT	ATTY. DOCKET NO./TITLE
13/476,310	05/21/2012	David M. Krinsky	6936-2-CON-2-1-4

CONFIRMATION NO. 7896

POA ACCEPTANCE LETTER



62574
Jason H. Vick
Sheridan Ross, PC
Suite # 1200
1560 Broadway
Denver, CO 80202

Date Mailed: 11/13/2012

NOTICE OF ACCEPTANCE OF POWER OF ATTORNEY

This is in response to the Power of Attorney filed 11/05/2012.

The Power of Attorney in this application is accepted. Correspondence in this application will be mailed to the above address as provided by 37 CFR 1.33.

/vvan/

Office of Data Management, Application Assistance Unit (571) 272-4000, or (571) 272-4200, or 1-888-786-0101



UNITED STATES PATENT AND TRADEMARK OFFICE

UNITED STATES DEPARTMENT OF COMMERCE
United States Patent and Trademark Office
Address: COMMISSIONER FOR PATENTS
P.O. Box 1450
Alexandria, Virginia 22313-1450
www.uspto.gov

APPLICATION NO.	FILING DATE	FIRST NAMED INVENTOR	ATTORNEY DOCKET NO.	CONFIRMATION NO.
13/476,310	05/21/2012	David M. Krinsky	5550-2-CON2-1-4	7896
62574	7590	11/05/2012	EXAMINER	
Jason H. Vick Sheridan Ross, PC Suite # 1200 1560 Broadway Denver, CO 80202			TRAN, KHANH C	
			ART UNIT	PAPER NUMBER
			2631	
			NOTIFICATION DATE	DELIVERY MODE
			11/05/2012	ELECTRONIC

Please find below and/or attached an Office communication concerning this application or proceeding.

The time period for reply, if any, is set in the attached communication.

Notice of the Office communication was sent electronically on above-indicated "Notification Date" to the following e-mail address(es):

jvick@sheridanross.com

Office Action Summary	Application No. 13/476,310	Applicant(s) KRINSKY ET AL.	
	Examiner KHANH C. TRAN	Art Unit 2631	

-- The MAILING DATE of this communication appears on the cover sheet with the correspondence address --
Period for Reply

A SHORTENED STATUTORY PERIOD FOR REPLY IS SET TO EXPIRE 3 MONTH(S) OR THIRTY (30) DAYS, WHICHEVER IS LONGER, FROM THE MAILING DATE OF THIS COMMUNICATION.

- Extensions of time may be available under the provisions of 37 CFR 1.136(a). In no event, however, may a reply be timely filed after SIX (6) MONTHS from the mailing date of this communication.
- If NO period for reply is specified above, the maximum statutory period will apply and will expire SIX (6) MONTHS from the mailing date of this communication.
- Failure to reply within the set or extended period for reply will, by statute, cause the application to become ABANDONED (35 U.S.C. § 133). Any reply received by the Office later than three months after the mailing date of this communication, even if timely filed, may reduce any earned patent term adjustment. See 37 CFR 1.704(b).

Status

- 1) Responsive to communication(s) filed on 21 May 2012.
- 2a) This action is **FINAL**. 2b) This action is non-final.
- 3) An election was made by the applicant in response to a restriction requirement set forth during the interview on _____; the restriction requirement and election have been incorporated into this action.
- 4) Since this application is in condition for allowance except for formal matters, prosecution as to the merits is closed in accordance with the practice under *Ex parte Quayle*, 1935 C.D. 11, 453 O.G. 213.

Disposition of Claims

- 5) Claim(s) 44-52 is/are pending in the application.
5a) Of the above claim(s) _____ is/are withdrawn from consideration.
- 6) Claim(s) _____ is/are allowed.
- 7) Claim(s) 44-52 is/are rejected.
- 8) Claim(s) _____ is/are objected to.
- 9) Claim(s) _____ are subject to restriction and/or election requirement.

Application Papers

- 10) The specification is objected to by the Examiner.
- 11) The drawing(s) filed on 21 May 2012 is/are: a) accepted or b) objected to by the Examiner.
Applicant may not request that any objection to the drawing(s) be held in abeyance. See 37 CFR 1.85(a).
Replacement drawing sheet(s) including the correction is required if the drawing(s) is objected to. See 37 CFR 1.121(d).
- 12) The oath or declaration is objected to by the Examiner. Note the attached Office Action or form PTO-152.

Priority under 35 U.S.C. § 119

- 13) Acknowledgment is made of a claim for foreign priority under 35 U.S.C. § 119(a)-(d) or (f).
a) All b) Some * c) None of:
1. Certified copies of the priority documents have been received.
2. Certified copies of the priority documents have been received in Application No. _____.
3. Copies of the certified copies of the priority documents have been received in this National Stage application from the International Bureau (PCT Rule 17.2(a)).

* See the attached detailed Office action for a list of the certified copies not received.

Attachment(s)

- 1) Notice of References Cited (PTO-892)
- 2) Notice of Draftsperson's Patent Drawing Review (PTO-948)
- 3) Information Disclosure Statement(s) (PTO/SB/08)
Paper No(s)/Mail Date _____.
- 4) Interview Summary (PTO-413)
Paper No(s)/Mail Date. _____.
- 5) Notice of Informal Patent Application
- 6) Other: _____.

DETAILED ACTION

Double Patenting

The nonstatutory double patenting rejection is based on a judicially created doctrine grounded in public policy (a policy reflected in the statute) so as to prevent the unjustified or improper timewise extension of the “right to exclude” granted by a patent and to prevent possible harassment by multiple assignees. A nonstatutory obviousness-type double patenting rejection is appropriate where the conflicting claims are not identical, but at least one examined application claim is not patentably distinct from the reference claim(s) because the examined application claim is either anticipated by, or would have been obvious over, the reference claim(s). See, e.g., *In re Berg*, 140 F.3d 1428, 46 USPQ2d 1226 (Fed. Cir. 1998); *In re Goodman*, 11 F.3d 1046, 29 USPQ2d 2010 (Fed. Cir. 1993); *In re Longi*, 759 F.2d 887, 225 USPQ 645 (Fed. Cir. 1985); *In re Van Ornum*, 686 F.2d 937, 214 USPQ 761 (CCPA 1982); *In re Vogel*, 422 F.2d 438, 164 USPQ 619 (CCPA 1970); and *In re Thorington*, 418 F.2d 528, 163 USPQ 644 (CCPA 1969).

A timely filed terminal disclaimer in compliance with 37 CFR 1.321(c) or 1.321(d) may be used to overcome an actual or provisional rejection based on a nonstatutory double patenting ground provided the conflicting application or patent either is shown to be commonly owned with this application, or claims an invention made as a result of activities undertaken within the scope of a joint research agreement.

Effective January 1, 1994, a registered attorney or agent of record may sign a terminal disclaimer. A terminal disclaimer signed by the assignee must fully comply with 37 CFR 3.73(b).

1. Claim 44 is rejected on the ground of nonstatutory obviousness-type double patenting as being unpatentable over claim 1 of ***U.S. Patent No. 8,238,412***. Although the conflicting claims are not identical, they are not patentably distinct from each other because the application claim defines an invention that is merely an obvious variation of that of the Patent claim.

Application claim differs from Patent claim in that application claim recites "*diagnostic information*" while patent claim recites "*test information*". Because "diagnostic information" corresponds to the test information, therefore, it would have been obvious for one of ordinary skill in the art at the time the invention was made that the application claim is merely an obvious variation of that of the patent claim.

2. Claim 45 is rejected on the same ground, as discussed in claim 44 rejection, of nonstatutory obviousness-type double patenting as being unpatentable over claim 2 of U.S. Patent No. 8,238,412.

3. Claim 46 is rejected on the same ground, as discussed in claim 44 rejection, of nonstatutory obviousness-type double patenting as being unpatentable over claim 3 of U.S. Patent No. 8,238,412.

4. Claim 47 is rejected on the same ground, as discussed in claim 44 rejection, of nonstatutory obviousness-type double patenting as being unpatentable over claim 4 of U.S. Patent No. 8,238,412.

5. Claim 48 is rejected on the same ground, as discussed in claim 44 rejection, of nonstatutory obviousness-type double patenting as being unpatentable over claim 5 of U.S. Patent No. 8,238,412.

6. Claim 49 is rejected on the same ground, as discussed in claim 44 rejection, of nonstatutory obviousness-type double patenting as being unpatentable over claim 6 of U.S. Patent No. 8,238,412.

7. Claim 50 is rejected on the same ground, as discussed in claim 44 rejection, of nonstatutory obviousness-type double patenting as being unpatentable over claim 7 of U.S. Patent No. 8,238,412.

8. Claim 51 is rejected on the same ground, as discussed in claim 44 rejection, of nonstatutory obviousness-type double patenting as being unpatentable over claim 8 of U.S. Patent No. 8,238,412.

9. Claim 52 is rejected on the same ground, as discussed in claim 44 rejection, of nonstatutory obviousness-type double patenting as being unpatentable over claim 13 of U.S. Patent No. 8,238,412.

10. Claim 44 is rejected on the ground of nonstatutory obviousness-type double patenting as being unpatentable over claim 1 of U.S. **Patent No. 7,835,430 B2**. Although the conflicting claims are not identical, they are not patentably distinct from each other because application claim defines an invention that is an obvious variation of that of the Patent claim. Patent claim differs from application claim in that Patent claim recites "*an array representing frequency domain received idle channel noise information*" while application claim recites "*an array representing power level per sub-channel information*". Because "frequency domain received idle channel noise information" and "power level per subchannel information" are test information, therefore, it would have been obvious for one of ordinary skill in the art at the time the invention was made to modify the Patent claim so that the array representing power level per sub-channel information as claimed in the application claim.

Furthermore, application claim differs from Patent claim in that application claim recites "*diagnostic information*" while patent claim recites "*test information*". Because "diagnostic information" corresponds to the test information, therefore, it would have been obvious for one of ordinary skill in the art at the time the invention was made that the application claim is merely an obvious variation of that of the patent claim.

11. Claim 46 is rejected on the ground, as discussed in claim 44, of nonstatutory obviousness-type double patenting as being unpatentable over claim 2 of *U.S. Patent No. 7,835,430 B2*.

12. Claim 48 is rejected on the ground, as discussed in claim 44, of nonstatutory obviousness-type double patenting as being unpatentable over claim 3 of *U.S. Patent No. 7,835,430 B2*.

13. Claim 50 is rejected on the ground, as discussed in claim 44, of nonstatutory obviousness-type double patenting as being unpatentable over claim 4 of *U.S. Patent No. 7,835,430 B2*.

14. Claim 44 is rejected on the ground of nonstatutory obviousness-type double patenting as being unpatentable over claim 1 of *U.S. Patent No. 7,889,784 B2*. Although the conflicting claims are not identical, they are not patentably distinct from each other because application claim defines an invention that is an obvious variation of that of the Patent claim. Patent claim differs from application claim in that Patent claim recites "*an array representing Signal to Noise ratio per subchannel during Showtime information*" while application claim recites "*an array representing power level per subchannel information*". Because "Signal to Noise ratio per subchannel during Showtime information" and "power level per subchannel information" are test information, therefore, it would have been obvious for one of ordinary skill in the art at the time the

invention was made to modify the Patent claim so that the array representing power level per sub-channel information as claimed in the application claim.

Furthermore, application claim differs from Patent claim in that application claim recites "*diagnostic information*" while patent claim recites "*test information*". Because "diagnostic information" corresponds to the test information, therefore, it would have been obvious for one of ordinary skill in the art at the time the invention was made that the application claim is merely an obvious variation of that of the patent claim.

15. Claim 46 is rejected on the ground, as discussed in claim 44, of nonstatutory obviousness-type double patenting as being unpatentable over claim 2 of *U.S. Patent No. 7,835,430 B2*.

16. Claim 48 is rejected on the ground, as discussed in claim 44, of nonstatutory obviousness-type double patenting as being unpatentable over claim 3 of *U.S. Patent No. 7,835,430 B2*.

17. Claim 50 is rejected on the ground, as discussed in claim 44, of nonstatutory obviousness-type double patenting as being unpatentable over claim 4 of *U.S. Patent No. 7,835,430 B2*.

Conclusion

18. Any inquiry concerning this communication or earlier communications from the examiner should be directed to KHANH C. TRAN whose telephone number is (571)272-3007. The examiner can normally be reached on Monday - Friday from 08:00 AM - 05:00 PM.

If attempts to reach the examiner by telephone are unsuccessful, the examiner's supervisor, Shuwang Liu can be reached on 571-272-3036. The fax phone number for the organization where this application or proceeding is assigned is 571-273-8300.

Information regarding the status of an application may be obtained from the Patent Application Information Retrieval (PAIR) system. Status information for published applications may be obtained from either Private PAIR or Public PAIR. Status information for unpublished applications is available through Private PAIR only. For more information about the PAIR system, see <http://pair-direct.uspto.gov>. Should you have questions on access to the Private PAIR system, contact the Electronic Business Center (EBC) at 866-217-9197 (toll-free). If you would like assistance from a USPTO Customer Service Representative or access to the automated information system, call 800-786-9199 (IN USA OR CANADA) or 571-272-1000.

KCT

*/KHANH C TRAN/
Primary Examiner, Art Unit 2631*

<i>Index of Claims</i> 	Application/Control No. 13476310	Applicant(s)/Patent Under Reexamination KRINSKY ET AL.
	Examiner KHANH C TRAN	Art Unit 2631

✓	Rejected	-	Cancelled	N	Non-Elected	A	Appeal
=	Allowed	÷	Restricted	I	Interference	O	Objected

Claims renumbered in the same order as presented by applicant
 CPA
 T.D.
 R.1.47

CLAIM		DATE							
Final	Original	10/27/2012							
	1	-							
	2	-							
	3	-							
	4	-							
	5	-							
	6	-							
	7	-							
	8	-							
	9	-							
	10	-							
	11	-							
	12	-							
	13	-							
	14	-							
	15	-							
	16	-							
	17	-							
	18	-							
	19	-							
	20	-							
	21	-							
	22	-							
	23	-							
	24	-							
	25	-							
	26	-							
	27	-							
	28	-							
	29	-							
	30	-							
	31	-							
	32	-							
	33	-							
	34	-							
	35	-							
	36	-							

<i>Index of Claims</i> 	Application/Control No. 13476310	Applicant(s)/Patent Under Reexamination KRINSKY ET AL.
	Examiner KHANH C TRAN	Art Unit 2631

✓	Rejected
=	Allowed

-	Cancelled
÷	Restricted

N	Non-Elected
I	Interference

A	Appeal
O	Objected

Claims renumbered in the same order as presented by applicant
 CPA
 T.D.
 R.1.47

CLAIM		DATE							
Final	Original	10/27/2012							
	37	-							
	38	-							
	39	-							
	40	-							
	41	-							
	42	-							
	43	-							
	44	✓							
	45	✓							
	46	✓							
	47	✓							
	48	✓							
	49	✓							
	50	✓							
	51	✓							
	52	✓							

Substitute for form 1449A/PTO				Complete if Known	
INFORMATION DISCLOSURE STATEMENT BY APPLICANT				Application Number	13/476310
				Filing Date	May 21, 2012
				First Named Inventor	David M. Krinsky et al.
				Art Unit	2631
				Examiner Name	KHANH C TRAN
Sheet	1	of	6	Attorney Docket Number	5550-2-CON2-1-4

U.S. PATENT DOCUMENTS					
Examiner Initials*	Cite No. ¹	Document Number Number-kind Code ^{2 (if known)}	Publication Date MM-DD-YYYY	Name of Patentee of Applicant of Cited Document	Pages, Columns, Lines, Where Relevant Passages or Relevant Figures Appear
/KCT/	1	4385384	05-24-1983	Rosbury et al.	
	2	4566100	01-21-1986	Mizuno et al.	
	3	5128619	07-07-1992	Bjork et al.	
	4	5361293	11-01-1994	Czerwiec	
	5	5608643	03-04-1997	Wichter et al.	
	6	5612960	03-18-1197	Stevens et al.	
	7	5864602	01-26-1999	Needle	
	8	5964891	10-12-1999	Caswell et al.	
	9	6073179	06-06-2000	Liu et al.	
	10	6075821	06-13-2000	Kao et al.	
	11	6175934	01-16-2001	Hershey et al.	
	12	6188717	02-13-2001	Kaiser et al.	
	13	6219378	04-17-2001	Wu	
	14	6249543	06-19-2001	Chow	
	15	6404774	06-11-2002	Jenness	
	16	6411678	06-25-2002	Tomlinson, Jr. et al.	
	17	6445773	09-03-2002	Liang et al.	
	18	6449307	09-10-2002	Ishikawa et al.	
	19	6512789	01-28-2003	Mirfakhraei	
	20	6631120	10-07-2003	Milbrandt	
	21	6633545	10-14-2003	Milbrandt	
	22	6636603	10-21-2003	Milbrandt	
	23	6658052	12-02-2003	Krinsky et al.	
	24	6725176	01-20-2004	Long et al.	
	25	6781513	08-24-2004	Korkosz et al.	
	26	7570686	08-04-2009	Krinsky et al.	
	27	7835430	11-16-2010	Krinsky et al.	
	28	7889784	02-15-2011	Krinsky et al.	
	29	2010/0226418	09-09-2010	Krinsky et al.	
/KCT/	30	2011/0103443	05-05-2011	Krinsky et al.	

Examiner Signature	/Khanh Tran/ (10/27/2012)	Date Considered	10/27/2012
--------------------	---------------------------	-----------------	------------

*EXAMINER: Initial if reference is considered, whether or not citation is in conformance and not considered. Include copy of this form with next communication to applicant.

ALL REFERENCES CONSIDERED EXCEPT WHERE LINED THROUGH. /KCT/

Substitute for form 1449A/PTO				Complete if Known	
INFORMATION DISCLOSURE STATEMENT BY APPLICANT				Application Number	13/476310
				Filing Date	May 21, 2012
				First Named Inventor	David M. Krinsky et al.
				Art Unit	2631
				Examiner Name	KHANH C TRAN
Sheet	2	of	6	Attorney Docket Number	5550-2-CON2-1-4

FOREIGN PATENT DOCUMENTS						
Examiner Initials*	Cite No. ¹	Foreign Patent Document Country Code ³ ; Number ⁴ ; Kind Code ⁵ (if known)	Publication Date MM-DD-YYYY	Name of Patentee or Applicant of Cited Document	Pages, Columns, Lines, Where Relevant Passages or Relevant Figures Appear	T ⁶
/KCT/	31	EP 0889615	01-07-2009	INTEGRATED TELECOM EXPRESS		
	32	GB 2303032	02-05-1997	SAMSUNG ELECTRONICS CO LTD		
	33	JP Hei6(1994)-003956	01-12-1994	TELEBIT CORPORATION		(believed to correspond to WO 86/07223 disclosed herein)
	34	JP-A-Hei10(1998)-513622	12-22-1998	ADC TELECOMMUNICATIONS INC		(believed to correspond to WO96/24995 cited herein)
	35	JP-A-Hei11(1999)-261665	09-24-1999	MATSUSHITA GRAPHIC COMMUNICATION SYSTEM INC.		(includes abstract)
	36	JP-A-Hei11(1999)-317723	11-16-1999	MOTOROLA INC		(includes abstract)
	37	JP-A-Hei11(1999)-508417	07-21-1999	ERICSSON TELEFON AB L M		(believed to correspond to WO97/01256 cited herein)
	38	WO 00/64130	10-26-2000	TERADYNE INC		
	39	WO 86/07223	12-04-1986	TELEBIT CORPORATION		(believed to correspond to JP Hei6(1994)-003956 disclosed herein)
/KCT/	40	WO 96/24995	08-15-1996	ADC TELECOMMUNICATIONS INC		

Examiner Signature	/Khanh Tran/ (10/27/2012)	Date Considered	10/27/2012
--------------------	---------------------------	-----------------	------------

*EXAMINER: Initial if reference is considered, whether or not citation is in conformance and not considered. Include copy of this form with next communication to applicant.

ALL REFERENCES CONSIDERED EXCEPT WHERE LINED THROUGH. /KCT/

Substitute for form 1449A/PTO				Complete if Known	
INFORMATION DISCLOSURE STATEMENT BY APPLICANT				Application Number	13/476310
				Filing Date	May 21, 2012
				First Named Inventor	David M. Krinsky et al.
				Art Unit	2631
				Examiner Name	KHANH C TRAN
Sheet	3	of	6	Attorney Docket Number	5550-2-CON2-1-4

/KCT/	41	WO 97/01256	01-09-1997	ERICSSON TELEFON AB L M		
/KCT/	42	WO 97/01900	01-16-1997	ERICSSON AUSTRIA AG		
/KCT/	43	WO 99/020027	04-22-1999	Aware, Inc.		
/KCT/	44	WO 99/26375	05-27-1999	TEKTRONIX INC		
/KCT/	45	WO 99/63427	12-09-1999	GTE LABORATORIES INC		
/KCT/	46	WO 99/67890	12-29-1999	PC TEL INC		

OTHER ART (Including Author, Title, Date, Pertinent Pages, etc.)		
Examiner Initials*	Cite No.¹	
/KCT/	47	BOETS et al., "Modeling Aspect of Transmission Line Networks," Proceedings Of The Instrumentation And Measurement Technology Conference, US, New York, IEEE, May 12, 1992, pp. 137-141, XP000343913 ISBN: 0-7803-0640-6
/KCT/	48	CIOFFI, John M., ADSL Maintenance with DMT, T1E1.4 ADSL Project, Amati Communications Corporation, Dec. 1, 1992, pages 1-14
/KCT/	49	LEWIS et al., "Extending Trouble Ticket System to Fault Diagnostics," IEEE Network, IEEE Inc. New York, US, Nov. 1, 1993, pp. 44-51, XP 000575228
/KCT/	50	"Asymmetric Digital Subscriber Line (ADSL) Transceivers," ITU-T G.992.1, Jun. 1999, pp. 91-117, 125, 126, 131, 132
/KCT/	51	ITU-T Recommendation G.992.2, "Splitterless asymmetric digital subscriber line (ADSL) transceivers," International Telecommunication Union, Jun. 1999, 179 pages
/KCT/	52	ITU-T Recommendation G.994.1, "Handshake procedures for digital subscriber line (DSL) transceivers," International Telecommunication Union, Jun. 1999, 56 pages
/KCT/	53	International Search Report for PCT/US01/00418 dated Jul. 16, 2001 (Attorney Ref. No. 5550-2-PCT), 4 pages

Examiner Signature	/Khanh Tran/ (10/27/2012)	Date Considered	10/27/2012
-----------------------	---------------------------	--------------------	------------

¹EXAMINER: Initial if reference is considered, whether or not citation is in conformance and not considered. Include copy of this form with next communication to applicant.

ALL REFERENCES CONSIDERED EXCEPT WHERE LINED THROUGH. /KCT/

Substitute for form 1449A/PTO				Complete if Known	
INFORMATION DISCLOSURE STATEMENT BY APPLICANT				Application Number	13/476310
				Filing Date	May 21, 2012
				First Named Inventor	David M. Krinsky et al.
				Art Unit	2631
				Examiner Name	KHANH C TRAN
Sheet	4	of	6	Attorney Docket Number	5550-2-CON2-1-4

/KCT/	54	Written Opinion for International (PCT) Patent Application No. PCT/US01/00418, mailed Jan. 18, 2002 (Attorney Ref. No. 5550-2-PCT), 2 pages
↓	55	International Preliminary Examination Report for International (PCT) Patent Application No. PCT/US01/00418, completed Mar. 9, 2002 (Attorney Ref. No. 5550-2-PCT), 2 pages
↓	56	PCT International Search Report dated Oct. 9, 2002 for PCT/US01/41653 (Attorney Ref. No. 5550-2-PCT-3)
↓	57	Examiner's First Report for Australian Patent Application No. 27669/01, dated Apr. 2, 2004 (Attorney Ref. No. 5550-2-PAU)
↓	58	Notice of Acceptance for Australian Patent Application No. 27669/01, dated Aug. 6, 2004 (Attorney Ref. No. 5550-2-PAU)
↓	59	Examiner's First Report for Australian Patent Application No. 2004203321, dated Nov. 16, 2006 (Attorney Ref. No. 5550-2-PAU-4)
↓	60	Notice of Acceptance for Australian Patent Application No. 2004203321, dated Aug. 7, 2008 (Attorney Ref. No. 5550-2-PAU-4)
↓	61	Examiner's First Report for Australian Patent Application No. 2008203520, mailed Mar. 9, 2009 (Attorney Ref. No. 5550-2-PAU-4-DIV)
↓	62	Notice of Acceptance for Australian Patent Application No. 2008203520, mailed Jul. 9, 2009 (Attorney Ref. No. 5550-2-PAU-4-DIV)
↓	63	Examination Report for Australian Patent Application No. 2009222537, dated Mar. 21, 2011 (Attorney Ref. No. 5550-2-PAU-4-DIV-2)
↓	64	Examination Report for Australian Patent Application No. 2009222537, dated May 27, 2011 (Attorney Ref. No. 5550-2-PAU-4-DIV-2)
↓	65	Notice of Acceptance for Australian Patent Application No. 2009222537, dated Aug. 25, 2011 (Attorney Ref. No. 5550-2-PAU-4-DIV-2)
↓	66	Official Action for Canadian Patent Application No. 2,394,491, mailed Nov. 24, 2009 (Attorney Ref. No. 5550-2-PCA)
↓	67	Notice of Allowance for Canadian Patent Application No. 2,394,491, dated Jul. 16, 2010 (Attorney Ref. No. 5550-2-PCA)
↓	68	Official Action for Canadian Patent Application No. 2,726,826, dated Jun. 30, 2011 (Attorney Ref. No. 5550-2-PCA-DIV)
/KCT/	69	Notice of Allowance for Canadian Patent Application No. 2,726,826, dated March 1, 2012 (Attorney Ref. No.: 5550-2-PCA-DIV)

Examiner Signature	/Khanh Tran/ (10/27/2012)	Date Considered	10/27/2012
--------------------	---------------------------	-----------------	------------

*EXAMINER: Initial if reference is considered, whether or not citation is in conformance and not considered. Include copy of this form with next communication to applicant.

ALL REFERENCES CONSIDERED EXCEPT WHERE LINED THROUGH. /KCT/

Substitute for form 1449A/PTO				Complete if Known	
INFORMATION DISCLOSURE STATEMENT BY APPLICANT				Application Number	13/476310
				Filing Date	May 21, 2012
				First Named Inventor	David M. Krinsky et al.
				Art Unit	2631
				Examiner Name	KHANH C TRAN
Sheet	5	of	6	Attorney Docket Number	5550-2-CON2-1-4

/KCT/	70	Official Action for European Patent Application No. 01901808.4, mailed Dec. 1, 2004 (Attorney Ref. No. 5550-2-PEP)
↓	71	Official Action for European Patent Application No. 01901808.4, mailed Sep. 14, 2005 (Attorney Ref. No. 5550-2-PEP)
↓	72	Communication about intention to grant a European patent for European Patent Application No. 01901808.4, mailed May 15, 2006 (Attorney Ref. No. 5550-2-PEP)
↓	73	European Search Report for European Patent Application No. EP 06022008 completed Jan. 8, 2007 (Attorney Ref. No. 5550-2-PEP-5)
↓	74	Official Action for European Patent Application No. EP 06022008.4, mailed Sept. 20, 2007 (Attorney Ref. No. 5550-2-PEP-5)
↓	75	Official Action for European Patent Application No. EP 06022008, dated Apr. 23, 2010 (Attorney Ref. No. 5550-2-PEP-5)
↓	76	Official Action for European Patent Application No. EP 06022008, mailed Jul. 7, 2010 (Attorney Ref. No. 5550-2-PEP-5)
↓	77	Communication Under Rule 71(3) EPC for European Patent Application No. EP 06022008, dated Apr. 4, 2011 (Attorney Ref. No. 5550-2-PEP-5)
↓	78	Notification of Reasons (including translation) for Refusal for Japanese Patent Application No. 2001-552611, Dispatched Date: December 7, 2009 (Attorney Ref. No. 5550-2-PJP)
↓	79	Official Action (including translation) for Japanese Patent Application No. 2001-552611, mailed Aug. 2, 2010 (Attorney Ref. No. 5550-2-PJP)
↓	80	Official Action (including translation) for Japanese Patent Application No. 2001-552611, mailed Mar. 28, 2011 (Attorney Ref. No. 5550-2-PJP)
↓	81	Official Action (including translation) for Japanese Patent Application No. 2008-191051, mailed Jul. 26, 2010 (Attorney Ref. No. 5550-2-PJP-DIV)
↓	82	Notice of Allowance for Japanese Patent Application No. 2008-190051, mailed Mar. 14, 2011 (Attorney Ref. No. 5550-2-PJP-DIV)
↓	83	Decision to Grant Patent (including translation) For Korean Patent Application No. 10-2002-7008794, dated Dec. 1, 2006 (Attorney Ref. No. 5550-2-PKR)
↓	84	Official Action for U.S. Patent Application No. 09/755,173, mailed Jun. 20, 2002 (Attorney Ref. No. 5550-2)
/KCT/	85	Official Action for U.S. Patent Application No. 09/755,173, mailed Sep. 24, 2002 (Attorney Ref. No. 5550-2)

Examiner Signature	/Khanh Tran/ (10/27/2012)	Date Considered	10/27/2012
--------------------	---------------------------	-----------------	------------

*EXAMINER: Initial if reference is considered, whether or not citation is in conformance and not considered. Include copy of this form with next communication to applicant.

ALL REFERENCES CONSIDERED EXCEPT WHERE LINED THROUGH. /KCT/

Substitute for form 1449A/PTO				Complete if Known	
INFORMATION DISCLOSURE STATEMENT BY APPLICANT				Application Number	13/476310
				Filing Date	May 21, 2012
				First Named Inventor	David M. Krinsky et al.
				Art Unit	2631
				Examiner Name	KHANH C TRAN
				Attorney Docket Number	5550-2-CON2-1-4
Sheet	6	of	6		

/KCT/	86	Official Action for U.S. Patent Application No. 09/755,173, mailed Mar. 14, 2003 (Attorney Ref. No. 5550-2)
↓	87	Notice of Allowance for U.S. Patent Application No. 09/755,173, mailed Jul. 1, 2003 (Attorney Ref. No. 5550-2)
↓	88	Official Action for U.S. Patent Application No. 10/619,691, mailed Oct. 31, 2006, 14 pages (Attorney Ref. No. 5550-2-CON-2)
↓	89	Official Action for U.S. Patent Application No. 10/619,691, mailed Mar. 30, 2007, 11 pages (Attorney Ref. No. 5550-2-CON-2)
↓	90	Official Action for U.S. Patent Application No. 10/619,691, mailed Jun. 13, 2008, 7 pages (Attorney Ref. No. 5550-2-CON-2)
↓	91	Official Action for U.S. Patent Application No. 10/619,691, mailed Oct. 20, 2008, 11 pages (Attorney Ref. No. 5550-2-CON-2)
↓	92	Notice of Allowance for U.S. Patent Application No. 10/619,691, mailed May 15, 2009, 9 pages (Attorney Ref. No. 5550-2-CON-2)
↓	93	Supplemental Notice of Allowability for U.S. Patent Application No. 10/619,691, mailed July 6, 2009, 5 pages (Attorney Ref. No. 5550-2-CON-2)
↓	94	Official Action for U.S. Patent Application No. 12/477,742, mailed Jun. 8, 2010 (Attorney's Ref. No. 5550-2-CON-2-1), 10 pages
↓	95	Official Action for U.S. Patent Application No. 12/477,742, mailed Aug. 16, 2010 (Attorney Ref. No. 5550-2-CON-2-1), 9 pages
↓	96	Notice of Allowance for U.S. Patent Application No. 12/477,742, mailed Sep. 7, 2010 (Attorney Ref. No. 5550-2-CON-2-1), 6 pages
↓	97	Office Action for U.S. Patent Application No. 12/779,660, mailed March 19, 2012 (Attorney Ref. No.: 5550-2-CON-2-1-1)
↓	98	Notice of Allowance for U.S. Patent Application No. 12/779,660, mailed April 26, 2012 (Attorney Ref. No.: 5550-2-CON-2-1-1)
↓	99	Official Action for U.S. Patent Application No. 12/779,708, mailed Sep. 29, 2010 (Attorney Ref. No. 5550-2-CON-2-1-2), 6 pages
↓	100	Official Action for U.S. Patent Application No. 12/779,708, mailed Dec. 15, 2010 (Attorney Ref. No. 5550-2-CON-2-1-2), 6 pages
/KCT/	101	Notice of Allowance for U.S. Patent Application No. 12/779,708, mailed Jan. 3, 2011 (Attorney Ref. No. 5550-2-CON-2-1-2), 6 pages

Examiner Signature	/Khanh Tran/ (10/27/2012)	Date Considered	10/27/2012
--------------------	---------------------------	-----------------	------------

*EXAMINER: Initial if reference is considered, whether or not citation is in conformance and not considered. Include copy of this form with next communication to applicant.

ALL REFERENCES CONSIDERED EXCEPT WHERE LINED THROUGH. /KCT/

Substitute for form 1449A/PTO				Complete if Known	
INFORMATION DISCLOSURE STATEMENT BY APPLICANT				Application Number	13/476310
				Filing Date	May 21, 2012
				First Named Inventor	David M. Krinsky et al.
				Art Unit	2631
				Examiner Name	KHANH C TRAN
Sheet	1	of	1	Attorney Docket Number	5550-2-CON2-1-4

U.S. PATENT DOCUMENTS					
Examiner Initials*	Cite No. ¹	Document Number Number-kind Code ^{2 (if known)}	Publication Date MM-DD-YYYY	Name of Patentee of Applicant of Cited Document	Pages, Columns, Lines, Where Relevant Passages or Relevant Figures Appear

FOREIGN PATENT DOCUMENTS						
Examiner Initials*	Cite No. ¹	Foreign Patent Document Country Code ³ ; Number ⁴ ; Kind Code ^{5 (if known)}	Publication Date MM-DD-YYYY	Name of Patentee or Applicant of Cited Document	Pages, Columns, Lines, Where Relevant Passages or Relevant Figures Appear	T ⁶
/KCT/	1	JP 60-206346	10-17-1985	FUJITSU LTD		(includes machine translation of abstract)
/KCT/	2	WO 99/18701	04-15-1999	ROCKWELL SEMICONDUCTOR SYSTEMS, INC.		

OTHER ART (Including Author, Title, Date, Pertinent Pages, etc.)		
Examiner Initials*	Cite No. ¹	
/KCT/	3	Official Action (including translation) for Japanese Patent Application No. 2011-012155 mailed June 4, 2012 (Attorney Ref. No.: 5550-2-PJP-DIV-2)

Examiner Signature	/Khanh Tran/ (10/27/2012)	Date Considered	10/27/2012
--------------------	---------------------------	-----------------	------------

*EXAMINER: Initial if reference is considered, whether or not citation is in conformance and not considered. Include copy of this form with next communication to applicant.

Search Notes 	Application/Control No. 13476310	Applicant(s)/Patent Under Reexamination KRINSKY ET AL.
	Examiner KHANH C TRAN	Art Unit 2631

SEARCHED			
Class	Subclass	Date	Examiner

SEARCH NOTES		
Search Notes	Date	Examiner
Update Searches on US Parent Cases 8,238,412 and 7,835,430	10/27/2012	KCT
Update Double Patenting Searches		KCT

INTERFERENCE SEARCH			
Class	Subclass	Date	Examiner

	/KHANH C TRAN/ Primary Examiner.Art Unit 2631
--	--

UNITED STATES PATENT AND TRADEMARK OFFICE

UNITED STATES DEPARTMENT OF COMMERCE
 United States Patent and Trademark Office
 Address: COMMISSIONER FOR PATENTS
 P.O. Box 1450
 Alexandria, Virginia 22313-1450
 www.uspto.gov

BIB DATA SHEET
CONFIRMATION NO. 7896

SERIAL NUMBER	FILING or 371(c) DATE	CLASS	GROUP ART UNIT	ATTORNEY DOCKET NO.		
13/476,310	05/21/2012	375	2631	5550-2-CON2-1-4		
APPLICANTS David M. Krinsky, Acton, MA; Robert Edmund Pizzano JR., Stoneham, MA;						
** CONTINUING DATA ***** This application is a CON of 12/779,660 05/13/2010 PAT 8,238,412 YES which is a CON of 12/477,742 06/03/2009 PAT 7,835,430 YES which is a CON of 10/619,691 07/16/2003 PAT 7,570,686 YES which is a CON of 09/755,173 01/08/2001 PAT 6,658,052 YES and claims benefit of 60/174,865 01/07/2000 YES ** FOREIGN APPLICATIONS ***** /KCT/ NO ** IF REQUIRED, FOREIGN FILING LICENSE GRANTED ** 05/31/2012						
Foreign Priority claimed <input type="checkbox"/> Yes <input checked="" type="checkbox"/> No 35 USC 119(a-d) conditions met <input type="checkbox"/> Yes <input type="checkbox"/> No Verified and Acknowledged /KANH C TRAN/ <small>Examiner's Signature</small>		<input type="checkbox"/> Met after Allowance KCT <small>Initials</small>	STATE OR COUNTRY MA	SHEETS DRAWINGS 2	TOTAL CLAIMS 9	INDEPENDENT CLAIMS 5
ADDRESS Jason H. Vick Sheridan Ross, PC Suite # 1200 1560 Broadway Denver, CO 80202 UNITED STATES						
TITLE Multicarrier Modulation Messaging for Power Level Per Subchannel Information						
FILING FEE RECEIVED 1750	FEES: Authority has been given in Paper No. _____ to charge/credit DEPOSIT ACCOUNT No. _____ for following:			<input type="checkbox"/> All Fees <input type="checkbox"/> 1.16 Fees (Filing) <input type="checkbox"/> 1.17 Fees (Processing Ext. of time) <input type="checkbox"/> 1.18 Fees (Issue) <input type="checkbox"/> Other _____ <input type="checkbox"/> Credit		

Under the Paperwork Reduction Act of 1995, no persons are required to respond to a collection of information unless it displays a valid OMB control number.

POWER OF ATTORNEY TO PROSECUTE APPLICATIONS BEFORE THE USPTO

I hereby revoke all previous powers of attorney given in the application identified in the attached statement under 37 CFR 3.73(c).

I hereby appoint:

Practitioners associated with Customer Number: 62574

OR

Practitioner(s) named below (if more than ten patent practitioners are to be named, then a customer number must be used):

Name	Registration Number	Name	Registration Number

As attorney(s) or agent(s) to represent the undersigned before the United States Patent and Trademark Office (USPTO) in connection with any and all patent applications assigned only to the undersigned according to the USPTO assignment records or assignments documents attached to this form in accordance with 37 CFR 3.73(c).

Please change the correspondence address for the application identified in the attached statement under 37 CFR 3.73(c) to:

The address associated with Customer Number: 62574

OR

<input type="checkbox"/>	Firm or Individual Name			
	Address			
	City	State	Zip	
	Country			
	Telephone	Email		

Assignee Name and Address: TQ DELTA, LLC
 805 Las Cimas Parkway, Suite 240
 Austin, Texas 78746

A copy of this form, together with a statement under 37 CFR 3.73(c) (Form PTO/AIA/96 or equivalent) is required to be Filed in each application in which this form is used. The statement under 37 CFR 3.73(c) may be completed by one of The practitioners appointed in this form, and must identify the application in which this Power of Attorney is to be filed.

SIGNATURE of Assignee of Record
 The individual whose signature and title is supplied below is authorized to act on behalf of the assignee

Signature		Date	10/4/12
Name	Mark K. Roche	Telephone	512-609-1810
Title	Managing Director		

This collection of information is required by 37 CFR 1.31, 1.32 and 1.33. The information is required to obtain or retain a benefit by the public which is to file (and by the USPTO to process) an application. Confidentiality is governed by 35 U.S.C. 122 and 37 CFR 1.11 and 1.14. This collection is estimated to take 3 minutes to complete, including gathering, preparing, and submitting the completed application form to the USPTO. Time will vary depending upon the individual case. Any comments on the amount of time you require to complete this form and/or suggestions for reducing this burden, should be sent to the Chief Information Officer, U.S. Patent and Trademark Office, U.S. Department of Commerce, P.O. Box 1450, Alexandria, VA 22313-1450. DO NOT SEND FEES OR COMPLETED FORMS TO THIS ADDRESS. SEND TO: Commissioner for Patents, P.O. Box 1450, Alexandria, VA 22313-1450.

If you need assistance in completing the form, call 1-800-PTO-9199 and select option 2.

Electronic Acknowledgement Receipt

EFS ID:	14148123
Application Number:	13476310
International Application Number:	
Confirmation Number:	7896
Title of Invention:	Multicarrier Modulation Messaging for Power Level Per Subchannel Information
First Named Inventor/Applicant Name:	David M. Krinsky
Customer Number:	62574
Filer:	Jason Vick/Joanne Vos
Filer Authorized By:	Jason Vick
Attorney Docket Number:	6936-2-CON-2-1-4
Receipt Date:	05-NOV-2012
Filing Date:	21-MAY-2012
Time Stamp:	14:16:09
Application Type:	Utility under 35 USC 111(a)

Payment information:

Submitted with Payment	no
------------------------	----

File Listing:

Document Number	Document Description	File Name	File Size(Bytes)/ Message Digest	Multi Part /.zip	Pages (if appl.)
1		EntityStatus_373c_w_POA.pdf	422373 0c5785afccfce6e5640a38dce7d9ece524cd e59c	yes	4

Multipart Description/PDF files in .zip description		
Document Description	Start	End
Miscellaneous Incoming Letter	1	1
Assignee showing of ownership per 37 CFR 3.73.	2	3
Power of Attorney	4	4
Warnings:		
Information:		
Total Files Size (in bytes):		422373
<p>This Acknowledgement Receipt evidences receipt on the noted date by the USPTO of the indicated documents, characterized by the applicant, and including page counts, where applicable. It serves as evidence of receipt similar to a Post Card, as described in MPEP 503.</p> <p><u>New Applications Under 35 U.S.C. 111</u> If a new application is being filed and the application includes the necessary components for a filing date (see 37 CFR 1.53(b)-(d) and MPEP 506), a Filing Receipt (37 CFR 1.54) will be issued in due course and the date shown on this Acknowledgement Receipt will establish the filing date of the application.</p> <p><u>National Stage of an International Application under 35 U.S.C. 371</u> If a timely submission to enter the national stage of an international application is compliant with the conditions of 35 U.S.C. 371 and other applicable requirements a Form PCT/DO/EO/903 indicating acceptance of the application as a national stage submission under 35 U.S.C. 371 will be issued in addition to the Filing Receipt, in due course.</p> <p><u>New International Application Filed with the USPTO as a Receiving Office</u> If a new international application is being filed and the international application includes the necessary components for an international filing date (see PCT Article 11 and MPEP 1810), a Notification of the International Application Number and of the International Filing Date (Form PCT/RO/105) will be issued in due course, subject to prescriptions concerning national security, and the date shown on this Acknowledgement Receipt will establish the international filing date of the application.</p>		

IN THE UNITED STATES PATENT AND TRADEMARK OFFICE

In Re the Application of: David M. Krinsky) Art Unit: 2631
Application No.: 13/476,310) Examiner: TRAN, Khanh C.
Filed: May 21, 2012) Confirmation No.: 7896
Atty. File No.: 6936-2-CON-2-1-4)

For: MULTICARRIER MODULATION MESSAGING FOR POWER LEVEL PER
SUBCHANNEL INFORMATION

ASSERTION OF ENTITLEMENT TO SMALL ENTITY STATUS

Commissioner for Patents
P.O. Box 1450
Alexandria, VA 22313-1450

Madam:

In accordance with MPEP §§ 509.02 and 509.03 AND 37 CFR 1.27, this document is being filed to inform the U.S. Patent Office of the change of status for the above-identified patent application from large entity status to small entity status. All fees paid to date have been paid as large entity status. No fees have yet been paid as small entity status. Due to the sale of the referenced patent application, the Applicant is now entitled to small entity status.

We respectfully request that small entity status be granted for the above-referenced patent application.

Please contact the undersigned if there are any questions regarding this notification.

Respectfully submitted,

SHERIDAN ROSS P.C.

Date: 5/21/12

By: 

Jason H. Vick
Reg. No. 45,285
1560 Broadway, Suite 1200
Denver, Colorado 80202
Telephone: 303-863-9700

STATEMENT UNDER 37 CFR 3.73(c)Applicant/Patent Owner: TQ DELTA, LLCApplication No./Patent No.: 13/476,310 Filed/Issue Date: May 21, 2012Titled: MULTICARRIER MODULATION MESSAGING FOR POWER LEVEL PER SUBCHANNEL INFORMATIONTQ DELTA, LLC, a Corporation

(Name of Assignee)

(Type of Assignee, e.g., corporation, partnership, university, government agency, etc.)

states that, for the patent application/patent identified above, it is (choose **one** of options 1, 2, 3 or 4 below):

1. The assignee of the entire right, title, and interest.
2. An assignee of less than the entire right, title, and interest (check applicable box):
- The extent (by percentage) of its ownership interest is _____%. Additional Statement(s) by the owners holding the balance of the interest must be submitted to account for 100% of the ownership interest.
- There are unspecified percentages of ownership. The other parties, including inventors, who together own the entire right, title and interest are:

Additional Statement(s) by the owner(s) holding the balance of the interest must be submitted to account for the entire right, title, and interest.

3. The assignee of an undivided interest in the entirety (a complete assignment from one of the joint inventors was made). The other parties, including inventors, who together own the entire right, title, and interest are:

Additional Statement(s) by the owner(s) holding the balance of the interest must be submitted to account for the entire right, title, and interest.

4. The recipient, via a court proceeding or the like (e.g., bankruptcy, probate), of an undivided interest in the entirety (a complete transfer of ownership interest was made). The certified document(s) showing the transfer is attached.

The interest identified in option 1, 2 or 3 above (not option 4) is evidenced by either (choose **one** of options A or B below):

- A. An assignment from the inventor(s) of the patent application/patent identified above. The assignment was recorded in the United States Patent and Trademark Office at Reel _____, Frame _____, or for which a copy thereof is attached.
- B. A chain of title from the inventor(s), of the patent application/patent identified above, to the current assignee as follows:

1. From: David M. Krinsky and Robert Edmund Pizzano, Jr. To: AWARE, INC.The document was recorded in the United States Patent and Trademark Office at Reel 012216, Frame 0842, or for which a copy thereof is attached.2. From: AWARE, INC. To: TQ DELTA, LLCThe document was recorded in the United States Patent and Trademark Office at Reel 029154, Frame 0937, or for which a copy thereof is attached.

[Page 1 of 2]

This collection of information is required by 37 CFR 3.73(b). The information is required to obtain or retain a benefit by the public which is to file (and by the USPTO to process) an application. Confidentiality is governed by 35 U.S.C. 122 and 37 CFR 1.11 and 1.14. This collection is estimated to take 12 minutes to complete, including gathering, preparing, and submitting the completed application form to the USPTO. Time will vary depending upon the individual case. Any comments on the amount of time you require to complete this form and/or suggestions for reducing this burden, should be sent to the Chief Information Officer, U.S. Patent and Trademark Office, U.S. Department of Commerce, P.O. Box 1450, Alexandria, VA 22313-1450. DO NOT SEND FEES OR COMPLETED FORMS TO THIS ADDRESS. **SEND TO: Commissioner for Patents, P.O. Box 1450, Alexandria, VA 22313-1450.**

If you need assistance in completing the form, call 1-800-PTO-9199 and select option 2.

Under the Paperwork Reduction Act of 1995, no persons are required to respond to a collection of information unless it displays a valid OMB control number.

STATEMENT UNDER 37 CFR 3.73(c)

3. From: _____ To: _____

The document was recorded in the United States Patent and Trademark Office at
Reel _____, Frame _____, or for which a copy thereof is attached.

4. From: _____ To: _____

The document was recorded in the United States Patent and Trademark Office at
Reel _____, Frame _____, or for which a copy thereof is attached.

5. From: _____ To: _____

The document was recorded in the United States Patent and Trademark Office at
Reel _____, Frame _____, or for which a copy thereof is attached.

6. From: _____ To: _____

The document was recorded in the United States Patent and Trademark Office at
Reel _____, Frame _____, or for which a copy thereof is attached.

Additional documents in the chain of title are listed on a supplemental sheet(s).

As required by 37 CFR 3.73(c)(1)(i), the documentary evidence of the chain of title from the original owner to the assignee was, or concurrently is being, submitted for recordation pursuant to 37 CFR 3.11.

[NOTE: A separate copy (i.e., a true copy of the original assignment document(s)) must be submitted to Assignment Division in accordance with 37 CFR Part 3, to record the assignment in the records of the USPTO. See MPEP 302.08]

The undersigned (whose title is supplied below) is authorized to act on behalf of the assignee.

Signature _____

Jason H. Vick

Printed or Typed Name

Date 5 Nov '13

45,285

Title or Registration Number



UNITED STATES PATENT AND TRADEMARK OFFICE

UNITED STATES DEPARTMENT OF COMMERCE
United States Patent and Trademark Office
Address: COMMISSIONER FOR PATENTS
P.O. Box 1450
Alexandria, Virginia 22313-1450
www.uspto.gov

Table with 4 columns: APPLICATION NUMBER (13/476,310), FILING OR 371(C) DATE (05/21/2012), FIRST NAMED APPLICANT (David M. Krinsky), ATTY. DOCKET NO./TITLE (5550-2-CON2-1-4)

CONFIRMATION NO. 7896

PUBLICATION NOTICE



62574
Jason H. Vick
Sheridan Ross, PC
Suite # 1200
1560 Broadway
Denver, CO 80202

Title: Multicarrier Modulation Messaging for Power Level Per Subchannel Information

Publication No. US-2012-0230476-A1

Publication Date: 09/13/2012

NOTICE OF PUBLICATION OF APPLICATION

The above-identified application will be electronically published as a patent application publication pursuant to 37 CFR 1.211, et seq. The patent application publication number and publication date are set forth above.

The publication may be accessed through the USPTO's publically available Searchable Databases via the Internet at www.uspto.gov. The direct link to access the publication is currently http://www.uspto.gov/patft/.

The publication process established by the Office does not provide for mailing a copy of the publication to applicant. A copy of the publication may be obtained from the Office upon payment of the appropriate fee set forth in 37 CFR 1.19(a)(1). Orders for copies of patent application publications are handled by the USPTO's Office of Public Records. The Office of Public Records can be reached by telephone at (703) 308-9726 or (800) 972-6382, by facsimile at (703) 305-8759, by mail addressed to the United States Patent and Trademark Office, Office of Public Records, Alexandria, VA 22313-1450 or via the Internet.

In addition, information on the status of the application, including the mailing date of Office actions and the dates of receipt of correspondence filed in the Office, may also be accessed via the Internet through the Patent Electronic Business Center at www.uspto.gov using the public side of the Patent Application Information and Retrieval (PAIR) system. The direct link to access this status information is currently http://pair.uspto.gov/. Prior to publication, such status information is confidential and may only be obtained by applicant using the private side of PAIR.

Further assistance in electronically accessing the publication, or about PAIR, is available by calling the Patent Electronic Business Center at 1-866-217-9197.

Office of Data Management, Application Assistance Unit (571) 272-4000, or (571) 272-4200, or 1-888-786-0101

Substitute for form 1449A/PTO				Complete if Known	
INFORMATION DISCLOSURE STATEMENT BY APPLICANT				Application Number	13/476310
				Filing Date	May 21, 2012
				First Named Inventor	David M. Krinsky et al.
				Art Unit	2611
				Examiner Name	
Sheet	1	of	1	Attorney Docket Number	5550-2-CON2-1-4

U.S. PATENT DOCUMENTS					
Examiner Initials*	Cite No. ¹	Document Number Number-kind Code ^{2 (if known)}	Publication Date MM-DD-YYYY	Name of Patentee or Applicant of Cited Document	Pages, Columns, Lines, Where Relevant Passages or Relevant Figures Appear

FOREIGN PATENT DOCUMENTS						
Examiner Initials*	Cite No. ¹	Foreign Patent Document Country Code ³ ; Number ⁴ ; Kind Code ^{5 (if known)}	Publication Date MM-DD-YYYY	Name of Patentee or Applicant of Cited Document	Pages, Columns, Lines, Where Relevant Passages or Relevant Figures Appear	T ⁶
	1	JP 60-206346	10-17-1985	FUJITSU LTD		(includes machine translation of abstract)
	2	WO 99/18701	04-15-1999	ROCKWELL SEMICONDUCTOR SYSTEMS, INC.		

OTHER ART (Including Author, Title, Date, Pertinent Pages, etc.)		
Examiner Initials*	Cite No. ¹	
	3	Official Action (including translation) for Japanese Patent Application No. 2011-012155 mailed June 4, 2012 (Attorney Ref. No.: 5550-2-PJP-DIV-2)

Examiner Signature		Date Considered	
--------------------	--	-----------------	--

*EXAMINER: Initial if reference is considered, whether or not citation is in conformance and not considered. Include copy of this form with next communication to applicant.

PATENT ABSTRACTS OF JAPAN

(11)Publication number : 60-206346

(43)Date of publication of application : 17.10.1985

(51)Int.Cl.

H04L 13/00

(21)Application number : 59-063897

(71)Applicant : FUJITSU LTD

(22)Date of filing : 30.03.1984

(72)Inventor : NAKAYAMA TAKESHI
MASUNAGA NAOHIRO
KOBAYASHI MITSUHIRO
SHINCHI MICHIIRO

(54) SETTING SYSTEM OF MODULATING AND DEMODULATING DEVICE

(57)Abstract:

PURPOSE: To reduce the number of set modulating and demodulating devices (MODEM) by storing test data and set data in MODEMs and transmitting and receiving test data following set data between stations and collating these data with data of stations themselves by reception-side MODEMs.

CONSTITUTION: A communication controller 2 sends a control signal to an MODEM 3-1. A processor μ P33 decodes this control signal and checks whether this control signal is a special control signal (a set mode signal or a test mode signal) or not; and if it indicates the set mode, the controller 2 switches a switching part 31 to its own station side and instructs the MODEM of the other party station to answer back the set mode and sends set data 35-1 stored in a memory 35. The MODEM of the other party station collates this data with set data of the station itself, and set data is turned back if they coincide with each other, but an error signal is answered back otherwise. When receiving said turned-back signal, the μ P33 reports the disaccord of the other party station to the controller 2 if this signal and set data 35-1 of its own station do not coincide with each other. If they coincide with each other, the μ P33 takes out test data 35-2 to be turned back in the memory 35 and performs the same operation as transmission and reception of set data.

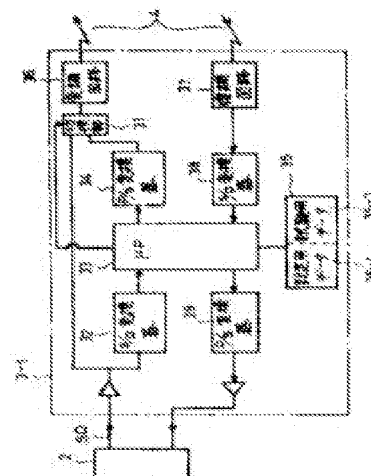

⑨ 日本国特許庁 (J P)

⑩ 特許出願公開

⑫ 公開特許公報 (A)

昭60-206346

⑮ Int. Cl. 4

識別記号

庁内整理番号

⑬ 公開 昭和60年(1985)10月17日

H 04 L 13/00

Q-7240-5K

審査請求 未請求 発明の数 1 (全4頁)

⑭ 発明の名称 変復調装置設定方式

⑯ 特 願 昭59-63897

⑰ 出 願 昭59(1984)3月30日

⑱ 発 明 者	中 山	毅	川崎市中原区上小田中1015番地	富士通株式会社内
⑲ 発 明 者	増 永	直 大	川崎市中原区上小田中1015番地	富士通株式会社内
⑲ 発 明 者	木 場	光 弘	川崎市中原区上小田中1015番地	富士通株式会社内
⑲ 発 明 者	新 地	通 宏	川崎市中原区上小田中1015番地	富士通株式会社内
⑳ 出 願 人	富 士 通 株 式 会 社		川崎市中原区上小田中1015番地	
㉑ 代 理 人	弁 理 士 松 岡 宏 四 郎			

明 細 書

1. 発明の名称

変復調装置設定方式

2. 特許請求の範囲

マイクロプロセッサを搭載する変復調装置間を通信回線を介して接続してデータ転送を行う通信システムにおいて、該変復調装置に設定用データと試験用データとをそれぞれ格納し、自局が前記設定用データを相手局に送出し、相手局が相手局の設定データと受信した前記設定データとの照合を行い、照合が取れた際に受信した設定データを返送し、前記受信した設定データを自局にて前記の照合を行い、続いて前記試験用データの上記転送及び返送を行って変復調装置の設定確認を行うことを特徴とする変復調装置設定方式。

3. 発明の詳細な説明

(a) 発明の技術分野

本発明はデータ転送を行う通信システムに広く用いられるマイクロプロセッサを搭載した変復調装置の設定方式に関する。

(b) 技術の背景と従来技術の問題点

遠隔地とデータの授受を行うのに、通信システムが用いられている。この通信システムは第1図に示すシステムが用いられている。即ちシステムは、データ処理装置1と通信制御装置2とマイクロプロセッサ搭載の復変調装置3-1、3-2と通信回線4と端末装置5-1、5-2とから構成されている。

このシステムを開設しようとする、データ処理装置1から各端末5-1、5-2に至る装置間に、オペレータを配置して、オペレータが送信を行い、この送信に対する応答をオペレータが行ってシステムの動作を確認するといった方法を採用している。然も、この確認は種々な試験項目に付いて行うことが必要であり、多大の工数を要するばかりでなく、折角試験確認を行っても、若し試験結果が不良であると、各装置の何れにて障害を発生したかを調査しなければならず、若し端末装置5-1の調査を行うとすると、端末装置5-1を変復調装置(以後モデムと記す)3-2から切り離して、モデ

ム3-2 に受信信号を返送する手段を付けて再試験を行うこととなる。上記した障害装置を検出するための切り分けに、更に工数を必要とすると言った欠点があった。

モデム設定に、工数を必要とせず容易に、設定の行える設定方式が要望されている。

(c) 発明の目的

本発明は従来の上記欠点を除去し、工数の削減をはかり、より効果的なモデム設定の行える変復調装置設定方式を提供することを目的とするものである。

(d) 発明の構成

上記目的は、マイクロプロセッサを搭載する変復調装置間を通信回線を介して接続してデータ転送を行う通信システムにおいて、該変復調装置に設定用データと試験用データとをそれぞれ格納し、自局が前記設定用データを相手局に送出し、相手局が相手局の設定データと受信した前記設定データとの照合を行い、照合が取れた際に受信した設定データを返送し、前記受信した設定データを自

局にて前記の照合を行い、続いて前記試験用データの上記転送及び返送を行って変復調装置の設定確認を行う本発明による変復調装置設定方式によって達成される。

即ち本発明においては、従来の人手による入力データを設定用データと試験用データとなして、各変復調装置に格納せしめ、自他局間に設定用データに続いて試験用データを授受せしめ、受信側変復調装置にて自局の設定用データ、或いは試験用データと照合をとることによって行われる。

かくて従来の方式に比して自動的に行われ、工数削減がはかれる変復調装置設定方式が得られる。

(e) 発明の実施例

以下第2図に示す実施例と第3図のフローチャートによって本発明の要旨を説明する。全図を通じて同一個所は同符号を付す。

第2図は本発明による変復調装置設定方式の構成図を示すもので、通信制御装置2はデータ処理装置から送られてくる制御信号をSD線によってモデム3-1 に送る。上記した制御信号は、本発明に

3

かかる特別な制御信号(例えば、これから設定を行うことを示す設定モード信号、或いはこれから折り返し試験を行うことを示す試験モード信号)をもっている。

モデム3-1 は制御信号を2分岐し、1分岐は直接、切換部31に、他分岐はシリアル/パラレル変換器(S/P変換器)32 とマイクロプロセッサ(以後MPと記す)33 とパラレル/シリアル変換器(P/S変換器)34 とを介して切換部31に至る。

S/P及びP/S変換器32、34は通信信号をMPを作動させる信号或いはその逆信号に変換する動作を行う部分で有り、以後その説明を略す。

通信制御装置2から送られてくる制御信号(第3図(1)に示す状態、以後第3図を省略し括弧付き数字で状態を示す)を受信したMP33は、制御信号を解読して(2)、特別な制御信号(設定モード、試験モード信号)の有無を調べる。無ければ、MP33は切換部31を1分岐側に、有れば他分岐側に接続するように切換部31を作動させる。即ち無ければ通常動作を行う(3)。

4

特別な制御信号が設定モードであると、MP33が解読を行うと(4)、MP33は切換部31を自側に切り換えると共に、相手局のモデム3-2に設定モードを送り返すように指示を行い、メモリ35が予め格納している設定用データ35-1を取り出して、変調回路36を介して送り込む(5)。

相手局のモデム3-2は送られて来た設定用データと自局の設定用データの照合を行い(6)、一致が取れば、設定用データを送り返す(7)。(第3図にて相手局の動作は点線で示す)不一致で有れば、このことをエラー信号として返送する(8)。

上記返送信号を復調回路37とS/P変換器38を介して受信したMP33は、自局の設定用データ35-1と送られた設定用データが一致するや否やの照合を行う(9)。不一致で有れば、上記した相手局の不一致(エラー信号)と共に、P/S変換器39を介して通信制御装置2に通知する(10)。

一致が取れば、MP33はメモリ35に予め格納された折り返しの試験用データ35-2を取り出し、上記した設定用データ授受と同一動作を行う(11)

5

6

乃至(17)。

上記説明はモードを設定モードから試験モードの順に行うように説明を行ったが、特殊な制御情報にて、試験モードを指定して折り返し試験のみを行っても、何等支障されることがないの言うまでもない。

設定モード及び試験モードにて、オペレータの手を煩わすことなく自動的に設定が行えるものとなる。

(f) 発明の効果

以上説明のように本発明においては、変復調装置の設定工数を著しく短縮し、通信システム設定に著しい経済的効果を示すものである。

4. 図面の簡単な説明

第1図は従来のシステム構成図、第2図は本発明による変復調装置設定方式の構成図、第3図は本発明のフローチャートを示す。

図において、3-1と3-2は変復調装置、4は通信回線、35はメモリ、35-1は設定用データ、35-2は試験用データをそれぞれ示す。

7

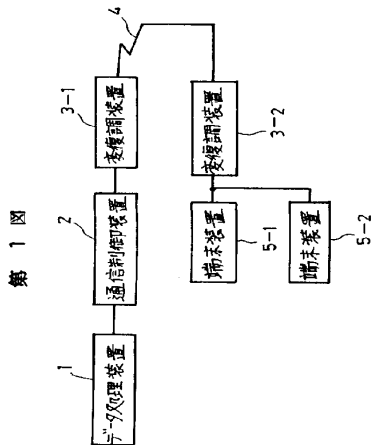

第1図

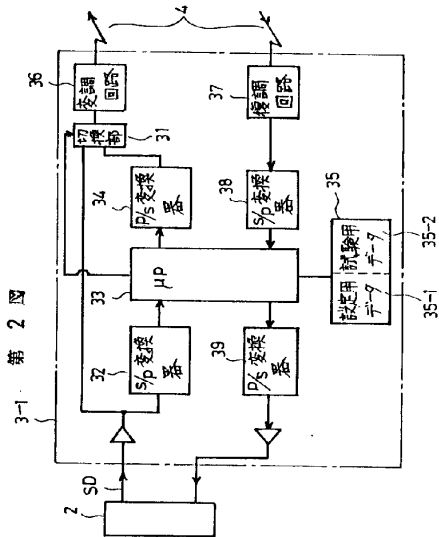

第2図

第 3 図

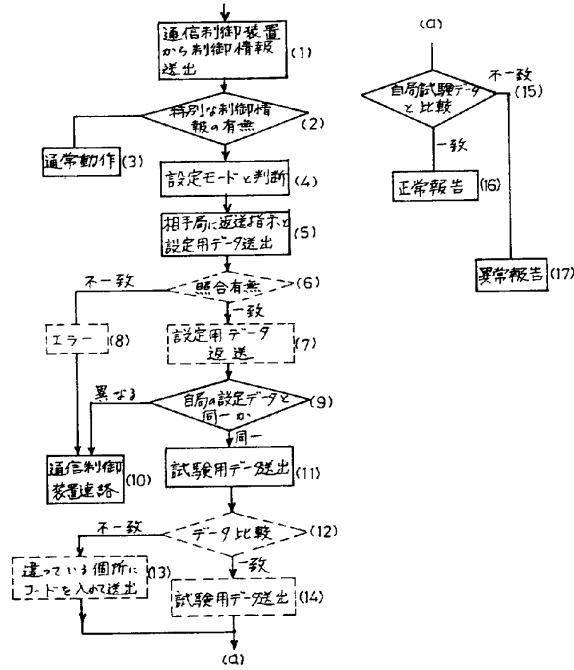



INTERNATIONAL APPLICATION PUBLISHED UNDER THE PATENT COOPERATION TREATY (PCT)

<p>(51) International Patent Classification ⁶ : H04L 27/00, H04M 11/06, H04L 1/12</p>	<p>A1</p>	<p>(11) International Publication Number: WO 99/18701 (43) International Publication Date: 15 April 1999 (15.04.99)</p>
---	------------------	--

<p>(21) International Application Number: PCT/US98/12735 (22) International Filing Date: 18 June 1998 (18.06.98) (30) Priority Data: 08/943,484 3 October 1997 (03.10.97) US (71) Applicant: ROCKWELL SEMICONDUCTOR SYSTEMS, INC. [US/US]; 4311 Jamboree Road, Newport Beach, CA 92660-3095 (US). (72) Inventors: HENDERSON, P., Michael; 12450 Butler Way, Tustin, CA 92782 (US). KO, Kenneth, D.; 2956 Saber Drive, Clearwater, FL 33759 (US). ZURANSKI, Edward, S.; 1313 Crescent Drive, Largo, FL 33770 (US). HAQUE, Jamal; 12701 North 50th Street #E-11, Tampa, FL 33617 (US). PATRAVALI, Shrenik, P.; Apartment #811, 500, 110th Avenue North, St. Petersburg, FL 33716 (US). RODRIGUEZ, Manuel, I.; 6759 23rd Street N., St. Petersburg, FL 33702 (US). SOUDERS, Keith, A.; 3627 Sugar Creek Drive, Tampa, FL 33619 (US). TZOURIS, Anthony, A.; 1969 Arvis Circle W., Clearwater, FL 33764 (US). (74) Agents: ZIEBERT, Joseph, N. et al.; Foley & Lardner, 777 East Wisconsin Avenue, Milwaukee, WI 53202 (US).</p>	<p>(81) Designated States: CN, JP, European patent (AT, BE, CH, CY, DE, DK, ES, FI, FR, GB, GR, IE, IT, LU, MC, NL, PT, SE). Published <i>With international search report.</i></p>
---	---

(54) Title: SPLITTERLESS DIGITAL SUBSCRIBER LINE COMMUNICATION SYSTEM

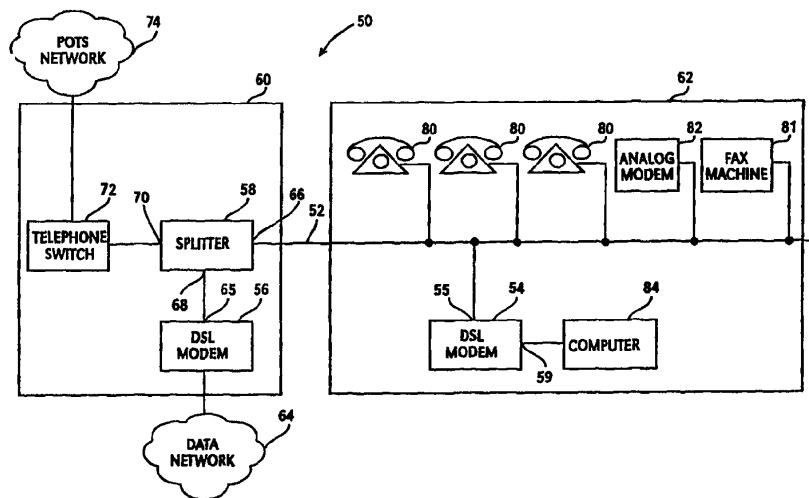

(57) Abstract
A digital subscriber line communication system does not require the use of a plain old telephone service (POTS) splitter in the resident's home. Digital signal processing techniques are utilized to adapt to varying subscriber line conditions due to POTS telephone equipment. The digital signal processing techniques eliminate the need for a splitter by reducing susceptibility to distortion due to varying subscriber line characteristics. The digital subscriber line modem utilizes quadrature amplitude modulated (QAM) signals and frequency division multiplexing. The digital subscriber line modem includes a control circuit which includes a rapid retrain circuit. The rapid retrain circuit can retrain the digital subscriber line modem in less than 0.5 seconds.

FOR THE PURPOSES OF INFORMATION ONLY

Codes used to identify States party to the PCT on the front pages of pamphlets publishing international applications under the PCT.

AL	Albania	ES	Spain	LS	Lesotho	SI	Slovenia
AM	Armenia	FI	Finland	LT	Lithuania	SK	Slovakia
AT	Austria	FR	France	LU	Luxembourg	SN	Senegal
AU	Australia	GA	Gabon	LV	Latvia	SZ	Swaziland
AZ	Azerbaijan	GB	United Kingdom	MC	Monaco	TD	Chad
BA	Bosnia and Herzegovina	GE	Georgia	MD	Republic of Moldova	TG	Togo
BB	Barbados	GH	Ghana	MG	Madagascar	TJ	Tajikistan
BE	Belgium	GN	Guinea	MK	The former Yugoslav Republic of Macedonia	TM	Turkmenistan
BF	Burkina Faso	GR	Greece	ML	Mali	TR	Turkey
BG	Bulgaria	HU	Hungary	MN	Mongolia	TT	Trinidad and Tobago
BJ	Benin	IE	Ireland	MR	Mauritania	UA	Ukraine
BR	Brazil	IL	Israel	MW	Malawi	UG	Uganda
BY	Belarus	IS	Iceland	MX	Mexico	US	United States of America
CA	Canada	IT	Italy	NE	Niger	UZ	Uzbekistan
CF	Central African Republic	JP	Japan	NL	Netherlands	VN	Viet Nam
CG	Congo	KE	Kenya	NO	Norway	YU	Yugoslavia
CH	Switzerland	KG	Kyrgyzstan	NZ	New Zealand	ZW	Zimbabwe
CI	Côte d'Ivoire	KP	Democratic People's Republic of Korea	PL	Poland		
CM	Cameroon	KR	Republic of Korea	PT	Portugal		
CN	China	KZ	Kazakistan	RO	Romania		
CU	Cuba	LC	Saint Lucia	RU	Russian Federation		
CZ	Czech Republic	LI	Liechtenstein	SD	Sudan		
DE	Germany	LK	Sri Lanka	SE	Sweden		
DK	Denmark	LR	Liberia	SG	Singapore		
EE	Estonia						

**SPLITTERLESS DIGITAL SUBSCRIBER
LINE COMMUNICATION SYSTEM**

FIELD OF THE INVENTION

The present invention relates generally to communication systems. More particularly, the present invention relates to a digital subscriber line modem.

5

BACKGROUND OF THE INVENTION

Explosive growth of the internet and the worldwide web is driving a need for increased communication data rates. In the corporate world, the need for high-speed access or data rates is met by dedicated high-speed links (perhaps T1/E1 frame relays or OC1 ATM systems) from the company to an internet access provider. Users in the company utilize a local area network (LAN) to gain access to an internet access router which is attached to the high-speed link. Unfortunately, home users of the internet do not often have a high-speed link and must rely on standard analog or plain old telephone service (POTS) line.

The need for high-speed access to the home is ever increasing due to the availability of information, data, programs, entertainment, and other computer applications on the worldwide web and the internet. For example, designers of web technology are constantly developing new ways to provide sensory experiences, including audio and video, to users of the web (web surfers). Higher-speed modems will be required so the home user can fully interact with incoming web and communication technologies.

Missing at the time of publication

Although designers of modems are continuously attempting to increase data rates, analog or POTS line modems are presently only able to reach data rates of up to 56 kilobits per second (Kbps). These conventional analog modems transmit and receive information on POTS subscriber lines through the public switched telephone network. The internet access provider is also coupled to the switched telephone network and transmits and receives information through it to the subscriber line.

Some home users have utilized ISDN equipment and subscriptions to obtain up to 128 Kbps access or data rates by the use of 2 B channels. ISDN equipment and subscriptions can be expensive and require a dedicated subscriber line. Heretofore, neither ISDN modems nor analog modems are capable of providing 256 Kbps or higher access between the home and the internet. Over one megabit per second (Mbps) data rates with analog modems or ISDN equipment do not seem feasible at this time.

A variety of communication technologies are competing to provide high-speed access to the home. For example, asymmetric digital subscriber lines (ADSL), cable modems, satellite broadcast, wireless LANs, and direct fiber connections to the home have all been suggested. Of these technologies, the asymmetric digital subscriber line can utilize the POTS subscriber line (the wire currently being utilized for POTS) between the home user (the residence) and the telephone company (the central office).

ADSL networks and protocols were developed in the early 1990's to allow telephone companies to provide video-on-demand service over the same wires which were being used to provide POTS. ADSL technologies include discrete multitone (DMT), carrierless amplitude and phase modulation (CAP), high-speed ADSL (HADS), and other technologies. Although the video-on-demand market has been less than originally expected, telephone companies have recognized the potential application of ADSL

technology for internet access and have begun limited offerings.

ADSL technology allows telephone companies to offer high-speed internet access and also allows telephone companies to remove internet traffic from the telephone switch network. Telephone companies cannot significantly profit from internet traffic in the telephone switch network due to regulatory considerations. In contrast, the telephone company can charge a separate access fee for ADSL services. The separate fee is not as restricted by regulatory considerations.

With reference to FIGURE 1, a conventional asymmetric ADSL (ADSL) system includes a copper twisted pair analog subscriber line 12, an ADSL modem 14, an ADSL modem 16, a band splitter 18, and a band splitter 20. Line 12 is a POTS local loop or wire connecting a central office 32 of the telephone company and a user's residence 22.

ADSL modem 14 is located in user's residence 22 and provides data to and from subscriber line 12. The data can be provided from line 12 through modem 14 to various equipment (not shown) coupled to modem 14. Equipment, such as, computers, network devices, servers, or other devices, can be attached to modem 14. Modem 14 communicates with a data network (not shown) coupled to modem 16 across line 12. ADSL modem 16 receives and transmits signals to and from line 12 to the data network. The data network can be coupled to other networks (not shown), including the internet.

At least one analog telephone 26, located in residence 22, can be coupled to subscriber line 12 through splitter 20 for communications across line 12 with telephone switch network 28. Telephone 26 and telephone switch network 28 (e.g., public-switched telephone (PST) network) are conventional systems well-known in the art. Alternatively, other analog

equipment, such as, facsimile machines, POTS modems, answering machines, and other telephonic equipment, can be coupled to line 12 through splitter 20.

5 System 10 requires that band splitter 18 and band splitter 20 be utilized to separate higher frequency ADSL signals and lower frequency POTS signals. For example, when the user makes a call from residence 22 on
10 telephone 26, lower frequency signals (under 4 kilohertz (kHz)) are provided through band splitter 20 to subscriber line 12 and through band splitter 18 to telephone switch network 28. Band splitter 18 prevents the lower frequency POTS signals from reaching ADSL modem 16. Similarly, band splitter 20 prevents any of the POTS signals from reaching modem 14.

15 ADSL modem 16 and ADSL modem 14 communicate higher frequency ADSL signals across subscriber line 12. The higher frequency ADSL signals are prevented from reaching telephone 26 and telephone switch network 28 by
20 band splitters 20 and 18, respectively. Splitters 18 and 20 can be passive analog filters or other devices which separate lower frequency POTS signals (below 4 kHz) from higher frequency ADSL signals (above 50 kHz).

The separation of the POTS signals and ADSL signals by splitters 18 and 20 is necessary to preserve
25 POTS voice and data traffic and ADSL data traffic. More particularly, splitters 18 and 20 can eliminate various effects associated with POTS equipment which may affect the transmission of ADSL signals on subscriber line 12. For example, the impedance of subscriber line 12 can
30 vary greatly as at least one telephone 26 is placed on-hook or off-hook. Additionally, the changes in impedance of subscriber line 12 can change the ADSL channel characteristics associated with subscriber line 12. These changes in characteristics can be particularly
35 destructive at the higher frequencies associated with ADSL signals (e.g., from 30 kHz to 1 megahertz (MHz) or more).

5 Additionally, splitters 18 and 20 isolate
subscriber line wiring within residence 22. The
impedance of such wiring is difficult to predict.
Further still, the POTS equipment, such as, telephone 26,
10 provides a source of noise and nonlinear distortion.
Noise can be caused by POTS voice traffic (e.g.,
shouting, loud laughter, etc.) and by POTS protocol, such
as, the ringing signal. The nonlinear distortion is due
15 to the nonlinear devices included in conventional
telephones. For example, transistor and diode circuits
in telephone 26 can add nonlinear distortion and cause
hard clipping of ADSL signals. Telephone 26 can further
generate harmonics which can reach the frequency ranges
associated with the ADSL signals. The nonlinear
20 components can also demodulate ADSL signals to cause a
hiss in the audio range which affects the POTS.

 Conventional ADSL technology has several
significant drawbacks. First, the costs associated with
ADSL services can be quite large. Telephone companies
25 incur costs related to central office equipment (ADSL
modems and ADSL network equipment) and installation costs
associated with the ADSL modems and network equipment.
Residential users incur subscriber equipment costs (ADSL
modems) and installation costs.

25 Installation costs are particularly expensive
for the residential user because trained service
personnel must travel to residence 22 to install band
splitter 20 (FIGURE 1). Although band splitter 18 must
30 be installed at the central office, this cost is somewhat
less because service personnel can install band splitter
18 within central office 32. Also, at office 32,
splitter 18 can be included in ADSL modem 16. However,
in residence 22, splitter 20 must be provided at the end
of subscriber line 12.

35 Additionally, ADSL equipment for the residence,
such as, modem 14, is expensive because the most complex
component of modem 14 (e.g., the receiver) is located at

residence 22 since high-speed transmissions are generally received within residence 22, and lower-speed transmissions are received by central office 32. In most internet applications, larger amounts of data are requested by the residential user rather than by the internet source. Receivers are typically much more complex than transmitters. These high-speed receivers often receive data at rates of over 6 Mbps.

ADSL equipment can be subject to cross-talk noise from other subscriber lines situated adjacent to subscriber line 12. For example, subscriber lines are often provided in a closely contained bundle. The close containment can cause cross-talk from other subscriber lines to be placed on subscriber line 12. Modem 14 must compensate for cross-talk noise.

Thus, there is a need for a digital subscriber line (DSL) communication system which does not require the use of a splitter in the residence. Further, there is a need for a communication system which allows a DSL modem to be connected directly to the subscriber line similar to the use of a conventional analog modem. Even further, there is a need for a less expensive DSL modem which does not utilize a considerably expensive high-speed receiver which operates at data rates over 2 Mbps. Further still, there is a need for a DSL modem which is not susceptible to errors due to POTS activity on the subscriber line.

SUMMARY OF THE INVENTION

The present invention relates generally to a digital subscriber line modem adapted to be coupled directly to a subscriber line. The modem is capable of simultaneous access to the subscriber line with other telephone equipment operating in a frequency band below 4,000 kilohertz. The modem includes a data terminal for coupling to the subscriber line and a control circuit coupled to the data terminal. The control circuit

receives and transmits signals to and from the data terminal. The control circuit utilizes digital signal processing techniques to adapt to varying subscriber line characteristics. The digital signal processing techniques allow the data terminal to be coupled directly to the subscriber line without the use of a splitter.

The present invention further relates to a digital subscriber line modem adapted to be coupled directly to a subscriber line. The modem is capable of simultaneous access to the subscriber line with other telephone equipment operating in a frequency band below 4 kilohertz. The modem includes a data terminal or subscriber line access adapted to be coupled to the subscriber line and a control means for receiving and transmitting signals to and from the data terminal. The control means includes an equalizer means for filtering the signals to accommodate characteristics of the subscriber line, an error processing means for providing a rapid retrain signal in response to an error condition, and a rapid retrain means for rapidly converging the equalizer means in response to the rapid retrain signal. The control means allows the data terminal to be coupled directly to the subscriber line without the use of a splitter.

The present invention even further relates to a communication system for use with a subscriber line. The communication system includes a user digital subscriber line modem located at a user site, a splitter located remotely from the user site, and an office digital subscriber line modem. The user digital subscriber line modem is coupled directly to the subscriber line and receives downstream signals from the subscriber line and transmits upstream signals to the subscriber line. The user digital subscriber line modem utilizes digital signal processing techniques to adapt to varying subscriber line characteristics. The digital signal processing techniques allow the data terminal to be

coupled directly to the subscriber line without the use
of a splitter between the subscriber line and the user
digital subscriber line modem. The splitter has a signal
terminal, a lower-frequency path terminal, and a higher-
5 frequency path terminal. The signal terminal is coupled
to the subscriber line. The lower-frequency path
terminal is coupled to a switched telephone network. The
office digital subscriber line modem is coupled to the
higher-frequency path terminal. The office digital
10 subscriber line modem transmits the downstream signals to
the subscriber line through the splitter and receives the
upstream signals from the subscriber line through the
splitter.

The present invention still further relates to
15 a customer asymmetric digital subscriber line modem for
use in a communication system, including a subscriber
line coupled between an office site and a user site. The
communication system includes a splitter located remotely
from the user site. The splitter has a signal terminal,
20 a lower-frequency path terminal, and a higher-frequency
path terminal. The signal terminal is coupled to the
subscriber line. The lower-frequency path terminal is
coupled to a telephone switch network. The communication
system also includes an office asymmetric digital
25 subscriber line modem coupled to the higher-frequency
path terminal. The office digital subscriber line modem
transmits downstream signals to the subscriber line
through the splitter and receives upstream signals from
the subscriber line through the splitter. The customer
30 asymmetric digital subscriber line modem includes a data
terminal for coupling directly to the subscriber line and
a control circuit. The control circuit is coupled to the
data terminal. The control circuit receives the
downstream signals in a first frequency range and
35 transmits the upstream signals in a second frequency
range. The control circuit utilizes digital signal
processing techniques to adapt to varying subscriber line

characteristics. The digital signal processing techniques allow the data terminal to be coupled directly to the subscriber line without the use of a splitter at the user site.

5 According to an exemplary aspect of the present invention, the communication system allows POTS signals and ADSL signals to be simultaneously transmitted on a subscriber line without the use of a splitter located in the user's residence. Digital signal processing
10 techniques are utilized to adapt to the varying subscriber line characteristics due to the activity of POTS equipment coupled to the subscriber line. The digital signal processing techniques eliminate the need for the splitter by changing data transmission
15 characteristics in accordance with the varying line characteristics.

 According to another exemplary aspect of the present invention, the DSL modem utilizes quadrature amplitude modulated (QAM) signals provided over the
20 subscriber line. The DSL modem transmits DSL signals in a first frequency range and receives DSL signals in a second frequency range in accordance with frequency division multiplexing techniques. The QAM signals are communicated in various constellation sizes from 4 to 256
25 points.

 In accordance with yet another exemplary aspect of the present invention, the DSL modem includes a rapid retrain circuit. The rapid retrain circuit rapidly retrains the modem-to-subscriber line characteristics in
30 as little time as less than 500 milliseconds. Additionally, an automatic gain control (AGC) circuit, which can be adjusted very rapidly, can also be provided. The rapid retrain circuit preferably eliminates steps related to initially converging the equalizer to reduce
35 retrain times. For example, the rapid retrain circuit may only adjust the AGC and converge the equalizer, starting at predicted coefficients. Echo canceling is

advantageously not needed because the modem transmits and receives in different frequency rates in accordance with frequency division multiplexing techniques.

5 In accordance with still another exemplary aspect of the present invention, the ADSL modem adjusts transmission rates in accordance with errors received on the digital subscriber line. The ADSL operates in accordance with a state diagram, wherein the data rate is decreased in response to error signals and increased when
10 a mean square error is below a threshold. The ADSL modem consistently monitors error signals to transmit and to receive at an optimal data rate.

15 BRIEF DESCRIPTION OF THE DRAWINGS

The invention will be further described with reference to the accompanying drawings, wherein like numerals denote like elements, and:

20 Fig. 1 is a schematic block diagram of a prior art ADSL communication system;

Fig. 2 is a schematic block diagram of a communication system in accordance with an exemplary
25 embodiment of the present invention, the communication system includes a DSL modem in accordance with another exemplary embodiment of the present invention;

30 Fig. 3 is a more detailed schematic block diagram of the DSL modem illustrated in FIGURE 2, the DSL modem includes a control circuit in accordance with yet another exemplary embodiment of the present invention;

35 Fig. 4 is a more detailed schematic block diagram of the control circuit illustrated in FIGURE 3; and

Fig. 5 is a state diagram showing an example of the operation of the DSL modem illustrated in Fig. 3.

5
10
15
20
25
30
35

**DETAILED DESCRIPTION OF PREFERRED
EXEMPLARY EMBODIMENTS**

With reference to FIGURE 2, a DSL communication system 50 includes a copper twisted pair subscriber line 52, a customer or residential DSL modem 54, a central office DSL modem 56, and a band splitter 58. Subscriber line 52 is a local loop, such as, a twisted pair of American wire gauge (AWG) 24 or 26 copper wires, which connects a central office 60 and a residence 62. Residence 62 can also be an office, building, or other facility. Similarly, central office 60 can be any facility associated with a provider of telephone services.

DSL modem 56 is coupled to a data network 64. Splitter 58 has a signal input 66 coupled to subscriber line 52, a higher-frequency output 68 coupled to DSL modem 56, and a lower-frequency output 70 coupled to a telephone switch 72. Telephone switch 72 is coupled to a POTS network 74. DSL modem 56, splitter 58, and telephone switch 72 are preferably located in central office 60. Alternatively, splitter 58 could be included as part of DSL modem 56 (e.g., DSL modem 56 is provided as an in-line device between subscriber line 52 and switch 72).

In residence 62, one or more telephones 80, analog facsimile machine 81, and analog modem 82 can be coupled directly to subscriber line 52 as is well known in the art. Telephones 80 can be any conventional communication devices, including answering machines, which can be coupled to subscriber line 52 for providing various POTS functions.

DSL modem 54 is coupled directly to subscriber line 52 at a data terminal, input/output or subscriber line access 55. DSL modem 54 is also coupled to a

computer 84. Alternatively, DSL modem 54 could be coupled to other devices (not shown), such as, a network, server, or other communication or computing device.

5 Unlike conventional ADSL or DSL communication systems, such as, system 10 described with reference to FIGURE 1, DSL modem 54 does not utilize a splitter between modem 54 and subscriber line 52 and between telephones 80 and subscriber line 52. DSL modem 54 advantageously utilizes digital signal processing techniques to adapt to varying subscriber line characteristics due to analog equipment, such as, telephones 80, machine 81, and modem 82, thereby eliminating the need for a splitter in residence 62. DSL modem 54 can operate concurrently with any of telephones 10 80, machine 81, and analog modem 82.

15 DSL modem 54 preferably includes subscriber line access 55 which is part of a standard connector, such as, an RJ11 walljack, and is coupled to subscriber line 52 similarly to conventional telephones 80 and analog modems 82. Access 55 is preferably a two-wire terminal.

20 Modem 54 can be provided as an internal device in computer 84, such as, on a PCI card, or as an external device. Preferably, modem 54 is an internal device so that high speed communications between modem 54 and computer 84 are not slowed by serial ports associated with computer 84. As an external device, modem 54 could be coupled through a printer port or a universal serial bus (USB) to computer 84. In FIGURE 3, modem 54 is 25 coupled to computer 84 via a data terminal 59.

30 Modem 54 is preferably implemented with a digital signal processing chip set. Other suitable processors can be utilized to run software modules to implement the operations described in the present application. The software modules implement most tasks 35 associated with modem 54. The tasks include digital filtering, line characterization, modulation,

demodulation, gain control, equalization, initialization error correction, test functions, and other modem requirements.

5 In operation, modem 54 adjusts operating characteristics, such as, equalization parameters, gain, and data rates, according to variables associated with line 52. Modem 54 is capable of receiving data at least at a one megabit per second (Mbps) data rate when line 52 is approximately 12 kilofeet and when all of telephones 10 80 are on-hook. Preferably, the reception (downstream) data rate is no worse than 256 Kbps data rate in the presence of POTS-related impairments associated with telephones 80. Modem 54 is capable of transmitting data at least at a 100 Kbps data rate when line 52 has a 15 length of 12 kilofeet and when all telephones 80 are on-hook. The transmission (upstream) data rate is preferably no worse than 64 Kbps in the presence of POTS-related impairments. By utilizing lower data rates than maximum ADSL data rates, such as, 6 Mbps, modem 54 can be 20 manufactured less expensively and is more able to withstand POTS-related impairments.

DSL modem 56 is similar to DSL modem 54. However, modem 56 preferably is a lower-power modem to minimize the power consumed by central office 60. 25 Additionally, modem 56 can have a sleep mode so that when modem 56 is not being accessed, significant power is not consumed by modem 56. Modem 56 can have a lower-cost receiver unit (not shown) because upstream data rates are lower than downstream data rates, as discussed above. In 30 the sleep mode, processors and other electronic devices in modem 56 are placed in a low-power or no-power mode by slowing or stopping clock signals within modem 56. If modem 54 is utilized within a laptop computer, lower-power techniques are desirable for modem 54 as well.

35 Modem 54 advantageously utilizes digital signal processing techniques to characterize and to classify interference sources going both to the POTS portion of

the spectrum from the DSL portion of the spectrum and from the POTS portion of the spectrum to the DSL portion of the spectrum. Modem 54 compensates for these interference sources with digital signal processing techniques. For example, when telephone 80 is brought off-hook, an impedance change occurs on line 52. Modem 54 can adjust data rates, gain characteristics, and filter parameters to compensate for the impedance change. Thus, modem 54 can utilize digital signal processing techniques to compensate for interference from POTS equipment, such as, telephone 80. Preferably, the digital signal processing techniques can rapidly adjust to interference sources so communication latency are not noticeable to the user.

In operation, DSL modems 54 and 56 communicate signals as quadrature amplitude modulated (QAM) signals. DSL modems 54 and 56 communicate data at various constellation sizes, ranging from 4 to 256 UC points. The data is transmitted in Reed-Solomon frames, where the R-S code rate is 0.941176471 (K/N) and $N = 68$ and $K = 64$. Alternatively, other values for N and K can be utilized to optimize data and frame rates.

DSL modem 54 transmits upstream signals in a lower-frequency range and receives downstream signals in a higher-frequency range, in accordance with frequency division multiplexing techniques. For example, modem 54 preferably transmits upstream signals at a carrier frequency between a lower band edge of 46 kHz and an upper band edge of 114 kHz. Modem 54 transmits upstream signals at a linerate (e.g., bandwidth or data rate) of 136 Kbps for a constellation size of 4 points and at a data rate of 340 Kbps for a constellation size of 32 points. Modem 56 receives the upstream signals at the same rates.

DSL modem 56 transmits downstream signals at a carrier frequency between a lower band edge of 265.5 kHz and an upper band edge of 605.5 kHz. DSL modem 56

transmits downstream signals at data rate of 680 Kbps for a constellation size of 4 points and at a data rate of 1.7 Mbps for a constellation rate of 32 points. Modem 54 receives the downstream signals at the same rates. A variety of carrier frequencies can be utilized, such as, 342 kHz, 367.5 kHz, or 418.5 kHz for transmitting downstream information. The use of frequency division multiplexing eliminates the need for an echo canceler (not shown) and eliminates nonlinear effects of echo canceling.

Modems 54 and 56 can utilize a variety of protocols to transmit and receive upstream and downstream signals. Modems 54 and 56 could additionally utilize a auxiliary channel within a control frequency band for transmitting control information between modems 54 and 56. Modems 54 and 56 can also utilize various error protocol, such as, Reed-Solomon coding, multidimensional trellis coding, or other protocols, to gain higher immunity to noise and other phone line impairments. Trellis coding is a method of forward error correction where each signal element is assigned a coded binary value representing the element's phase and amplitude. The coding allows the receiving modem to determine, based on the value of the receiving signal, whether or not a given signal element is received in error.

With reference to FIGURE 3, modem 54 includes a high-pass filter 57 coupled between access 55 which is coupled to subscriber line 52 and a control circuit 92. High-pass filter 57 preferably has a threshold frequency above 4 kHz and beneath the lowest band carrier edge for the DSL signals (e.g., 46 kHz) to prevent POTS signal from entering modem 54. Control circuit 92 includes a rapid retrain module or circuit 94, an error processor 96, a line characterization module or circuit 104, and an equalizer 98. Additionally, an automatic gain control circuit (AGC) 102 is disposed between high-pass filter 57 and equalizer 98.

Circuit 102 can be an analog circuit. Alternatively, circuit 102 can be a digital circuit located in control circuit 92 or a hybrid analog and digital circuit. Filter 57 can be a passive filter with a threshold frequency of 10 kHz.

Equalizer 98 is a digital filter through which signals are transmitted and received to and from line 52. Equalizer 98 can be on a receive side of control circuit 92, a transmit side of control circuit 92, or both. Equalizer 98 is an adaptive compensation circuit for counteracting distortions on line 52.

Equalizer 98 is preferably a decision feedback equalizer defined by tap coefficients. Equalizer 98 is implemented by a digital signal processor (not shown) running a software program. In the receive mode, equalizer 98 provides filtered signals to error processor 96 as well as other portions of control circuit 92. The filtered signals are processed by circuit 92 and provided at data terminal 59. In the transmit mode, other filters or equalizers can filter or pre-emphasize signals provided by modem 54 to line 52.

Equalizer 98 must be converged (e.g., tuned) so the constellation associated with QAM signals are appropriately situated for decoding. Alternatively, equalizer 98 can be any device, digital or analog, for reducing frequency or phase distortion, or both, on subscriber line 52 by the introduction of filtering to compensate for the difference in attenuation or time delay, or both, at various frequencies in the transmission and reception spectrums.

Rapid retrain circuit 94 provides control signals (e.g., tap coefficients) to equalizer 98 to converge equalizer 98, thereby compensating for distortion on line 52. Rapid retrain circuit 94 causes equalizer 98 to converge in response to a raise rate rapid retrain signal provided by error processor 96 on a line 97. Rapid retrain circuit 94 also causes equalizer

98 to converge in response to a lower rate rapid retrain signal provided by error processor on a line 95. Rapid retrain circuit 94 can utilize tap coefficients developed by line characterization circuit 104. As discussed in more detail below, circuit 104 can store a number of coefficients for known error conditions in a flash memory or other storage device. Alternately, the coefficients can be interactively determined, as discussed below.

Error processor 96 monitors signals from equalizer 98 to determine if significant errors in the communication of data on line 52 are occurring. If significant errors are occurring, a lower rate rapid retrain signal is provided on line 95 so rapid retrain circuit 94 retrains modem 54. If few errors are occurring, and data is communicated at a lower data rate, a raise rate retrain signal is provided on line 97 so circuit 94 retrains modem 54 so data is communicated at a higher rate.

As part of the retrain operation, modem 54 performs a variety of tasks to ensure accurate data communication. A retrain operation for modem 54 can include the following tasks: reacquiring timing from a remote modem, such as, modem 56, converging equalizer 98, and adjusting the data rate. Additionally, the retrain operation can also include characterizing line 52 and adjusting the automatic gain control circuit 102. Depending on modem 54 and line 52 parameters, circuit 94 can perform different levels of retrain operations.

In a slow retrain or initialization operation, a retrain operation from initiation variables (e.g., scratch) of modem 54 can include reacquiring timing, characterizing line 52, adjusting circuit 102 from initialization variables, converging equalizer 98 from initialization variables, and determining a data rate. Characterizing line 52 can involve performing line characterization routines by circuit 104, as discussed below. Since adjustments to circuit 102 and converging

equalizer 98 is an interactive process, these procedures can be time-consuming. The slow retrain can take as long 6.5 seconds. Nonetheless, time is saved, even in the slow retrain operation when compared to conventional modems, because modem 54 advantageously does not utilize an echo canceler (not shown). The echo canceler typically must be reset during a retrain operation.

To save time, a rapid-retrain operation can eliminate one or more of the above steps or perform the above steps from predicted variables (variables which are initially closer to the desired value than initialization variables). In a rapid retrain operation, the line characterization step is eliminated, and circuit 102 and 98 are adjusted slightly or converged from a stored coefficient. For example, according to a rapid retrain operation, the center tap coefficient for equalizer 98 can be determined, and the remaining coefficients can be adjusted based on the difference between the determined center tap coefficient and the previous center tap coefficient.

According to another rapid retrain operation, prestored tap coefficients are utilized so equalizer 98 does not have to be significantly converged. The tap coefficients are chosen based upon conditions recognized by circuit 94, such as, telephone 80 (FIGURE 2) being brought off-hook. The adjustment of the gain circuit 102 can be restricted to a range to save time.

System and application parameters associated with modem 54 and line 52 can define the amount of time required for a rapid retrain of modem 54. For example, a rapid retrain may occur in a particular amount of real time, such as, less than 0.5 seconds. A rapid retrain within 0.5 seconds assures that the transmission of data is not affected for perceivable delays as modem 54 is retrained. A 0.5 second retrain operation is a vast improvement over the conventional 6.5 seconds for initialization retrain operations. Alternatively, the

rapid retrain operation may occur in a much shorter time period, particularly if error processor 96 and rapid retrain circuit 94 are able to determine what changes on subscriber line 52 have caused errors. Circuit 94 can
5 react to those changes and access a database or other data indicative of coefficients for equalizer 98, gain parameters for circuit 102, data rates, or other criteria for appropriate communication of data on line 52. For example, such a database could be stored on computer 84
10 coupled to modem 54 (FIGURE 2). Further still, a very rapid retrain operation could occur where equalizer 98 does not have to be converged, and only the gain of circuit 102 needs to be adjusted. Thus, rapid retrain circuit 94 is capable of retraining modem 54 in a rapid
15 manner in response to error processor 96 discovering that there are errors in the communication of data on subscriber line 52.

When rapid retrain circuit 94 performs a retrain operation, data rates associated with modem 54
20 are adjusted to maximize the data rate, while maintaining the integrity of the communications. For instance, if error processor 96 determines that a particular number of errors are occurring, rapid retrain circuit 94 may adjust the data rate down by reducing the size of the
25 constellation or reducing the symbol rate. Error processor 96 can determine errors which require an adjustment of equalizer 98, such as, tangential error, radial error, or other errors. Error processor 96 can also react to trellis-coding errors, Reed-Solomon errors,
30 mean squared error levels, or other errors. Alternatively, if error processor 96 determines that the mean squared error level is below a threshold, rapid retrain circuit 94 can retrain modem 54 and adjust the data rate upward by increasing the size of the
35 constellation or increasing the symbol rate. The threshold used to compare the mean squared error, as well

as other errors, is variable according to user parameters and the data rate.

Line characterization circuit 104 can perform a variety of operations to characterize line 52 for the development of tap coefficients for equalizer 98 and of other parameters for modem 54. Line characterization tests can be performed when modem 54 is at initialization, in an idle mode, or in a non-idle mode. According to one line characterization test, tones or test patterns are transmitted across line 52 in accordance with a test protocol. Modems 54 and 56 cooperate to determine characteristics of line 52 based upon received tones or test patterns. In a non-idle mode, the test pattern can be sent and analyzed during the time the user is awaiting communications from the Internet. Further, a separate control channel can be utilized to send control information necessary to characterize line 52.

In another embodiment, circuit 104 can enter a learn mode and analyze line 52 under a variety of conditions. While in the learn mode, the user can bring telephone 80 (FIGURE 2) off-hook in response to instructions generated by software on computer 84. Modem 54 can characterize line 52 during those particular conditions. Coefficients for equalizer 98 can be generated for those conditions and stored for a rapid retrain operation. Further still, circuit 104 can perform line-probing operations similar to the V.34 standard.

In yet another embodiment, an echo canceler (not shown) can be utilized on a transmit side of modem 54 to remove the transmitted signals in the transmit frequency spectrum. Control circuit 92 can analyze the characteristics in the transmit frequency spectrum of line 52. This analysis can be performed during non-idle modes. The portion of equalizer 98 on the transmit side can be adjusted according to the analysis to predistort

or to preemphasize the transmitted signals. Digital frequency processing techniques can also include various error signal analysis, correction, and manipulation to determine when a rapid retrain is necessary as well as techniques for rapidly converging an equalizer associated with modem 54.

With reference to FIGURE 4, error processor 96 includes a Reed-Solomon decoder 120, a mean squared error calculator 122, and a Trellis decoder 124. Reed-Solomon decoder 120 analyzes frames of data provided from error decoder 124 and determines if a frame error occurs and if errors are occurring in the frame. Reed-Solomon decoder 120 can correct errors as is well known in the art. Alternatively, calculator 122 can be replaced by other systems which can provide an indication of signal-to-noise ratios.

Reed-Solomon decoder 120, calculator 122, and Trellis decoder 124 provide a lower rapid retrain signal when error conditions indicate that the data rate should be lowered. Rapid retrain circuit 94 performs a rapid retrain operation and lowers the data rate in response to the lower rate rapid retrain signal at input 95. In contrast, when the mean squared error calculator 122 provides a raise rate rapid retrain signal at input 97, rapid retrain circuit 94 raises the data rate and performs a rapid retrain. Thus, modem 54 automatically raises or lowers its data rate to maintain high-speed and accurate communications in the presence of POTS-related impairments.

Although the data rates associated with modems 54 and 56 are somewhat lower than maximum data rates associated with conventional ADSL systems, these data rates are still significantly larger than conventional analog modem capabilities. The lower data rates allow modems 54 and 56 to use smaller constellation sizes and frequency division multiplexing, as well as withstand POTS-related impairments.

Digital signal processing techniques can include rapid retrain operations where the modem is adjusted to changing subscriber line techniques due to POTS operations. Such adjustments can include adjusting automatic gain control circuit 102, converging equalizer 98, and error processing. Further, digital signal processing techniques can include line characterization techniques performed by circuit 104 (FIGURE 3).

With reference to FIGURE 5, operation of modem 54 is described with reference to FIGURES 2-5. FIGURE 5 is a state diagram showing rapid retrain operations for modem 54. Modem 54 preferably always provides the highest data rate available on line 52, according to a rate-adaptive digital subscriber line technique. Modem 56 should have the ability to set a maximum downstream data rate so that the telephone company can limit the maximum downstream data rate to avoid advantaging subscribers who live close to office 60. According to this technique, modems 54 and 56 constantly adjust the data rates to reach maximum data rate potential on subscriber line 52 (FIGURE 2).

In FIGURE 5, modem 54 (FIGURE 2) is capable of a start-up state 100, an idle state 102, a data mode state 104, a fast retrain reduce rate state 106, and a fast retrain increase rate state 108. When off or idle, modem 54 transfers from idle state 102 to start-up state 100 when it receives a start-up command.

In start-up state 100, modem 54 is initialized. During initialization, timing is acquired from a remote modem, such as, modem 56, automatic gain circuit 102 is adjusted, equalizer 98 is converged, the carrier phase is locked, line 52 is characterized, and a data rate is selected. If start-up is successfully completed, modem 54 advances to data mode state 104, where data is communicated across subscriber line 52.

As data is communicated at the data rate selected during start-up state 100, error signals from

error processor 92 are consistently checked. If the error signals are within an acceptable level, modem 54 is maintained in data mode state 104. However, if the error signals are above a particular level, modem 54 enters fast retrain reduce rate state 106. In state 106, modem 54 reduces the data rate, adjusts automatic control circuit 102, re-acquires timing, and converges equalizer 98. Preferably, equalizer 98 is retrained from stored coefficient values to reduce the amount of time required for retraining. Alternatively, another mode (not shown) may be entered where just the automatic gain control 102 (FIGURE 3) is adjusted, and the data rate is not changed to compensate for errors.

In state 106, if the fast retrain fails, another fast retrain is attempted. If more than two fast retrain attempts fail, modem 54 returns to start-up state 104. As at initialization, if start-up fails, modem 54 enters idle state 102.

If the fast retrain operation is successfully completed, modem 54 returns to data mode state 104 and continues to communicate data at a lower data rate. The data rate can be adjusted incrementally or by other relationships. For example, if the errors are due to known POTS activity, particular data rates may be known to operate during that activity, and those data rates may be chosen.

In state 104, if the mean square error signal provided by mean square error calculator 122 is below a threshold, modem 54 enters fast retrain increase rate state 108. Modem 54 is retrained in state 108 similarly to state 106, except that the data rate is increased. If the fast-retrain operation is completed successfully, modem 54 changes from state 108 to state 104 and continues normal data communication operations at the faster rate. If the fast retrain operation fails in state 108, modem 54 enters state 106 and performs a fast retrain reduce rate operation.

5 It is understood that, while the detailed drawings
and specific examples given describe preferred exemplary
embodiments of the present invention, they are for the
purpose of illustration only. The apparatus and method
of the invention is not limited to the precise details
and conditions disclosed. For example, although QAM
signals and frequency division multiplexing is utilized,
other protocols can be implemented. Also, although
parameters related to a rapid retrain operation are
10 discussed, the rapid retrain operation may include a
variety of steps for ensuring the integrity of the data
channel at high data rates. Various changes may be made
to the details disclosed without departing from the
spirit of the invention which is defined by the following
15 claims.

CLAIMS

What is claimed is:

1 1. A digital subscriber line modem adapted to be
2 coupled directly to a subscriber line, the modem being
3 capable of simultaneous access to the subscriber line
4 with other telephone equipment operating in a frequency
5 band below four kilohertz, the modem comprising:
6 a data terminal for coupling to the subscriber line;
7 and
8 a control circuit coupled to the data terminal, the
9 control circuit receiving and transmitting signals to and
10 from the data terminal, the control circuit utilizing
11 digital signal processing techniques to adapt to varying
12 subscriber line characteristics, whereby the digital
13 signal processing techniques allow the data terminal to
14 be coupled directly to the subscriber line without the
15 use of a splitter.

1 2. The digital subscriber line modem of claim 1,
2 further comprising:
3 a high pass filter coupled between the data terminal
4 and the control circuit, the high pass filter attenuating
5 lower frequency signals at the data terminal.

1 3. The digital subscriber line modem of claim 2,
2 wherein the high pass filter attenuates the lower
3 frequency signals having a frequency below 46 kHz.

1 4. The digital subscriber line modem of claim 1,
2 wherein the subscriber line is a twisted pair copper
3 line.

1 5. The digital subscriber line modem of claim 1,
2 wherein the control circuit transmits and receives the
3 data in a data mode, the control circuit transmitting and
4 receiving the data at data rates, the control circuit
5 adjusting the data rates in response to varying
6 conditions due to the other telephone equipment on the
7 subscriber line.

1 6. The digital subscriber line modem of claim 5,
2 wherein the varying conditions include changes in the
3 impedance of the subscriber line due to hooking or
4 unhooking the other telephone equipment.

1 7. The digital subscriber line modem of claim 1,
2 wherein the control circuit further includes a rapid
3 retrain circuit and an error processing circuit, the
4 error processing circuit providing a lower rate retrain
5 signal when the error processing circuit detects a
6 predetermined number of errors associated with the data,
7 wherein the retrain circuit lowers data rates of the
8 modem in response to the lower rate retrain signal.

1 8. The digital subscriber line modem of claim 1,
2 wherein the control circuit further includes a rapid

1 retrain circuit and an error processing circuit, the
2 error processing circuit providing a raise rate retrain
3 signal when an error signal is below a threshold, wherein
4 the retrain circuit raises the data rates of the modem in
5 response to the raise rate retrain signal.

1 9. The digital subscriber line modem of claim 8,
2 wherein the threshold varies with the data rates, and the
3 error signal is a mean squared error signal.

1 10. The digital subscriber line modem of claim 7,
2 wherein the rapid retrain circuit rapidly retrains the
3 modem in response to the lower rate retrain signal.

1 11. The digital subscriber line modem of claim 10,
2 wherein rapid retraining includes reacquiring timing from
3 a remote unit providing the data on the subscriber line,
4 and converging the equalizer.

1 12. The digital subscriber line modem of claim 11,
2 wherein the rapidly retraining occurs within 500
3 milliseconds.

1 13. The digital subscriber line modem of claim 7,
2 wherein the signals are quadrature amplitude modulated
3 signals and are frequency division multiplexed for
4 transmit signals and receive signals.

1 14. A digital subscriber line modem adapted to be
2 coupled directly to a subscriber line, the modem being
3 capable of simultaneous access to the subscriber line
4 with other telephone equipment operating in a frequency
5 band below the four thousand kilohertz band, the modem
6 comprising:

7 a data terminal adapted to be coupled to the
8 subscriber line; and

9 a control means for receiving and transmitting
10 signals to and from the data terminal, the control means
11 including an equalizer means for filtering the signals to
12 accommodate characteristics of the subscriber line, an
13 error-processing means for providing a rapid retrain
14 signal in response to an error condition, and a rapid
15 retrain means for rapidly converging the equalizer means
16 in response to the rapid retrain signal, whereby the
17 control means allows the data terminal to be coupled
18 directly to the subscriber line without the use of a
19 splitter.

1 15. The digital subscriber line modem of claim 14,
2 wherein the equalizer means filters according to
3 coefficients, and the rapid retrain means provides
4 initial coefficients in accordance with a line condition
5 related to the error condition.

1 16. The digital subscriber line modem of claim 15,
2 wherein the control means further includes a database for

1 storing the initial coefficients for various line
2 conditions, the rapid retrain means selecting the initial
3 coefficients for a particular line condition in response
4 to the error signal.

1 17. The digital subscriber modem of claim 14,
2 wherein the error processing means monitors a noise
3 level at an output of the equalizer means.

1 18. The digital subscriber line modem of claim 14,
2 wherein the error processing means receives a Reed-
3 Solomon error signal or a Viterbi error signal.

1 19. The digital subscriber line modem of claim 14,
2 wherein the rapid retrain means lowers a data rate of the
3 signals without characterizing the subscriber line.

1 20. A communication system for use with a
2 subscriber line, the communication system comprising:
3 a user digital subscriber line modem, located at a
4 user site, the user digital subscriber line mode being
5 coupled directly to the subscriber line and receiving
6 downstream signals from the subscriber line and
7 transmitting upstream signals to the subscriber line and
8 utilizing digital signal processing techniques to adapt
9 to varying subscriber line characteristics, whereby the
10 digital-processing techniques allow the customer digital
11 subscriber line modem to be coupled directly to the

1 subscriber line without the use of a splitter between the
2 subscriber line and the user digital subscriber modem;

3 a splitter, located remote from the user site, the
4 splitter having a signal terminal, a lower frequency path
5 terminal, and a higher-frequency path terminal, the
6 signal terminal being coupled to the subscriber line, the
7 lower frequency path terminal being coupled to a switched
8 telephone network; and

9 an office digital subscriber line modem coupled to
10 the higher frequency path terminal, the office digital
11 subscriber line transmitting the downstream signals to
12 the subscriber line through the splitter and receiving
13 the upstream signals from the subscriber line through the
14 splitter.

1 21. The communication system of claim 20, wherein
2 the digital signal processing techniques include rapidly
3 retraining the user digital subscriber line modem in
4 response to varying characteristics of the subscriber
5 line.

1 22. A customer asymmetric digital subscriber line
2 modem for use in a communication system including a
3 subscriber line coupled between an office site and a user
4 site, the communication system including a splitter
5 located remote from the user site, the splitter having a
6 signal terminal, a lower frequency path terminal, and a
7 higher frequency path terminal, the signal terminal being

1 coupled to the subscriber line, the lower frequency path
2 terminal being coupled to a telephone switch network, the
3 communication system including an office asymmetric
4 digital subscriber line modem coupled to the higher
5 frequency path terminal, the office digital subscriber
6 line modem transmitting downstream signals to the
7 subscriber line through the splitter and receiving
8 upstream signals from the subscriber line through the
9 splitter, the customer asymmetric modem comprising:
10 a data terminal for coupling directly to the
11 subscriber line; and
12 a control circuit coupled to the data terminal, the
13 control circuit receiving the downstream signals in a
14 first frequency range and transmitting the upstream
15 signals in a second frequency range, the control circuit
16 utilizing digital signal processing techniques to adapt
17 to varying subscriber line characteristics, whereby the
18 digital processing techniques allow the data terminal to
19 be coupled directly to the subscriber line without the
20 use of splitter at the user site.

1 23. The modem of claim 22, wherein the upstream
2 signals and downstream signals are quadrature amplitude
3 modulated signals.

1 24. The modem of claim 22, further comprising:
2 a high pass filter coupled between the data terminal
3 and the control circuit, the high pass filter attenuating
4 lower frequency signals at the data terminal.

1 25. The modem of claim 21, wherein the control
2 circuit adjusts data rates of the upstream and downstream
3 signals in response to varying conditions on the
4 subscriber line.

1 26. The modem of claim 25, wherein the varying
2 conditions include changes in the impedance of the
3 subscriber line due to hooking or unhooking other
4 telephone equipment coupled to the subscriber line.

1 27. The modem of claim 22, wherein the control
2 circuit further includes a rapid retrain module and an
3 error processing module, the error processing module
4 providing a lower rate retrain signal when the error
5 processing module detects a predetermined number of
6 errors associated with the upstream and downstream
7 signals, wherein the retrain circuit lowers the data
8 rates of the modem and rapidly retrains the modem in
9 response to the lower rate retrain signal.

1 28. The digital subscriber line modem of claim 27,
2 wherein the error processing module provides a raise rate
3 retrain signal when a mean error signal is below a

1 threshold, wherein the retrain circuit raises the data
2 rates of the modem in response to the raise rate retrain
3 signal.

1 29. A digital subscriber line modem adapted to be
2 coupled directly to a subscriber line, the modem being
3 capable of simultaneous access to the subscriber line
4 with other telephone equipment operating in a frequency
5 band below 4 kHz, the modem comprising:
6 a data terminal for coupling to the subscriber
7 line; and
8 a control circuit coupled to the data terminal
9 to receive and transmit signals therefrom, the control
10 circuit being configured to adapt to characteristics of
11 the subscriber line to receive and transmit digital data
12 from the subscriber line without a splitter coupled
13 between the data terminal and the subscriber line.

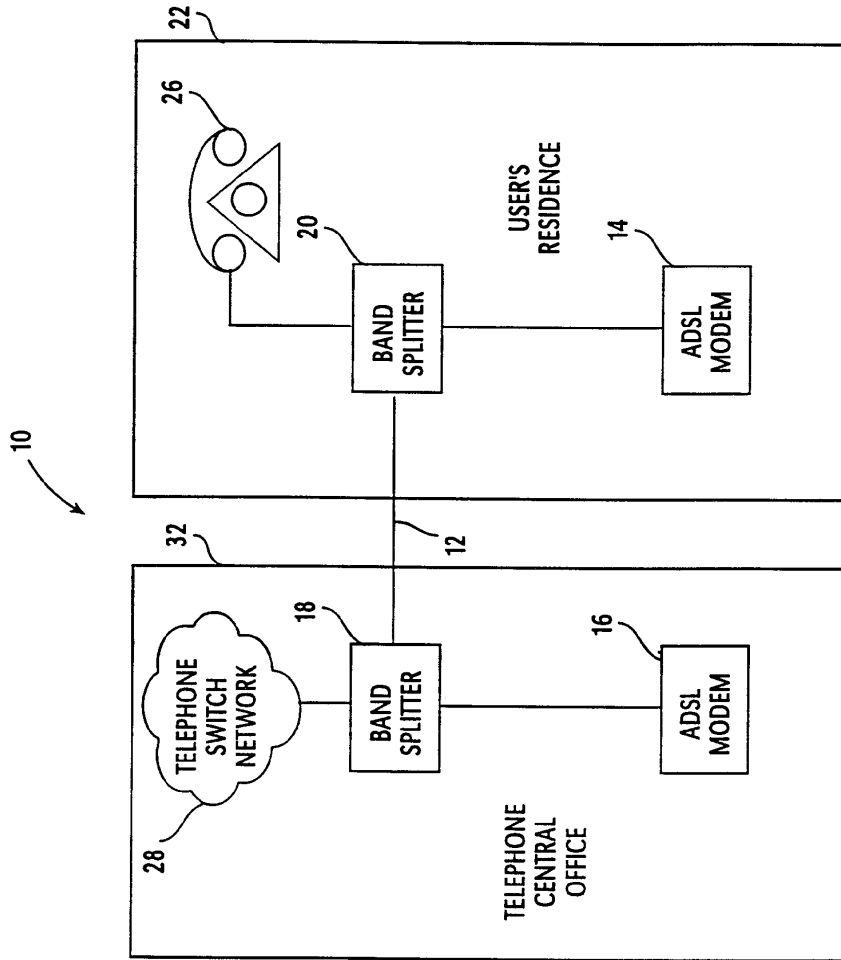

(PRIOR ART)
FIG. 1

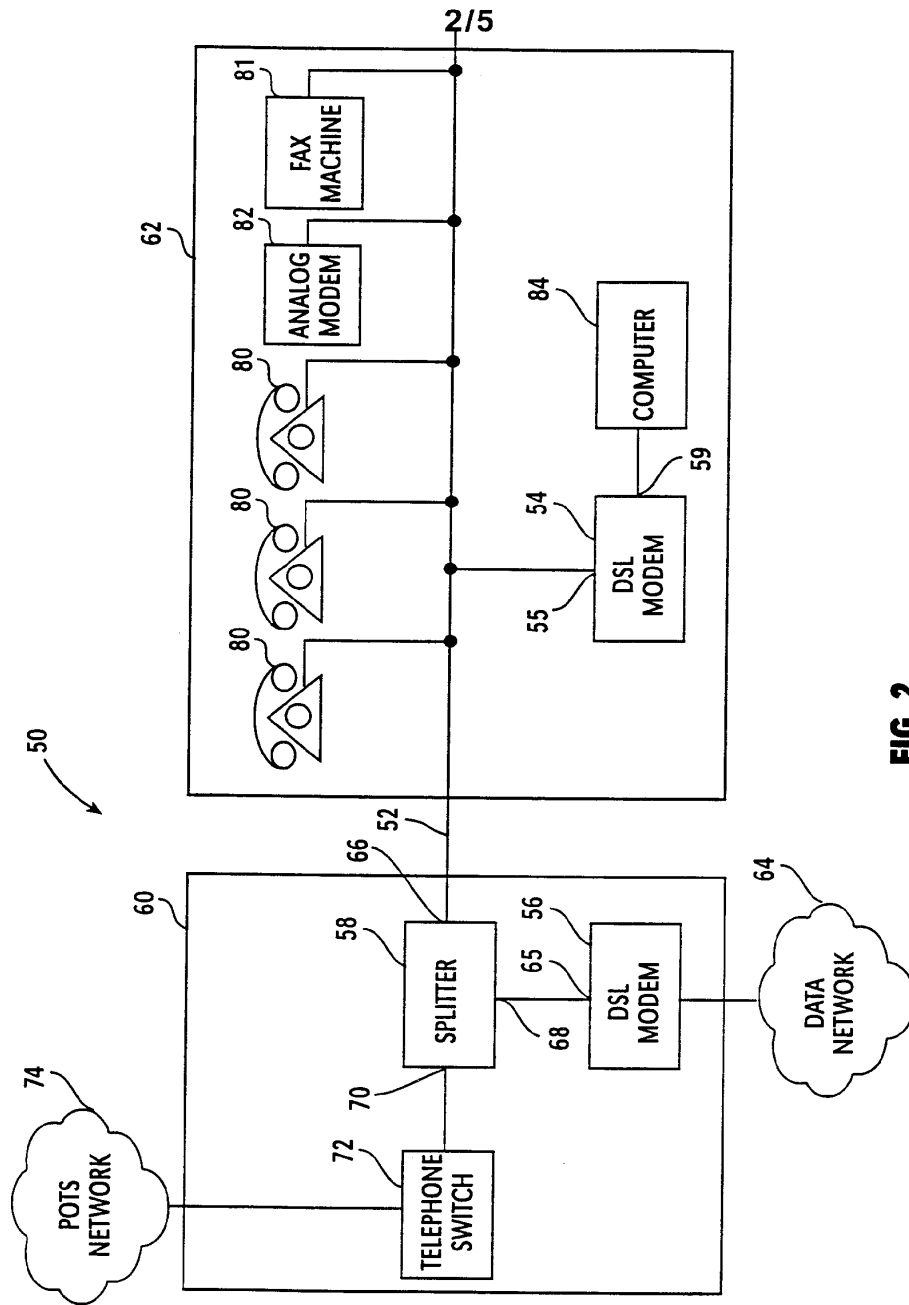

FIG. 2

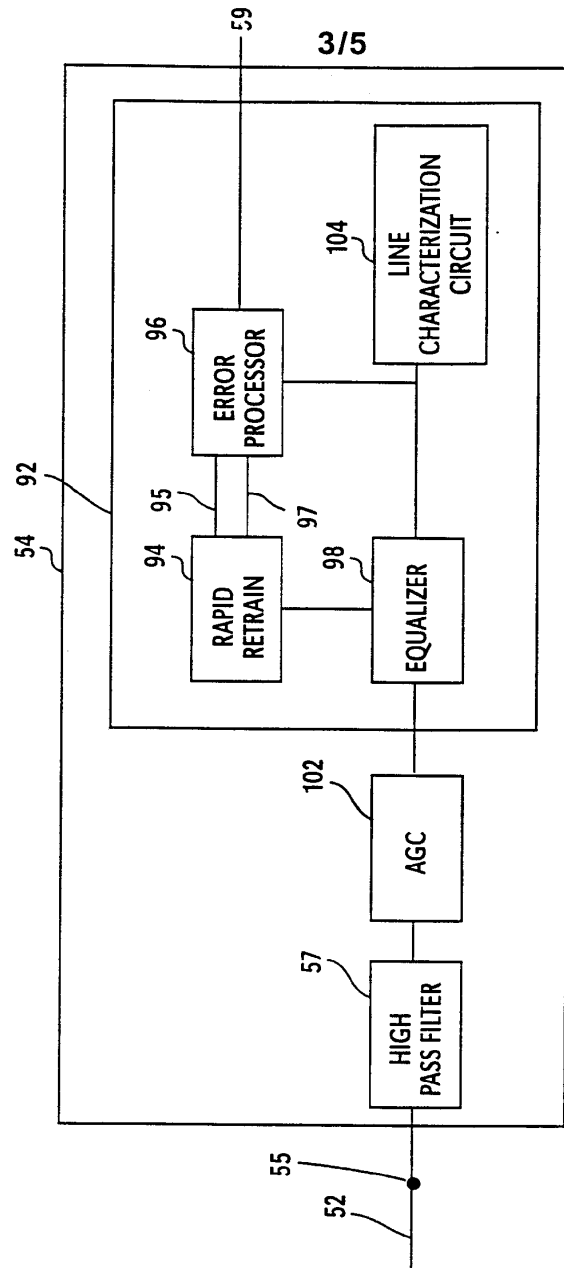

FIG. 3

SUBSTITUTE SHEET (RULE 26)

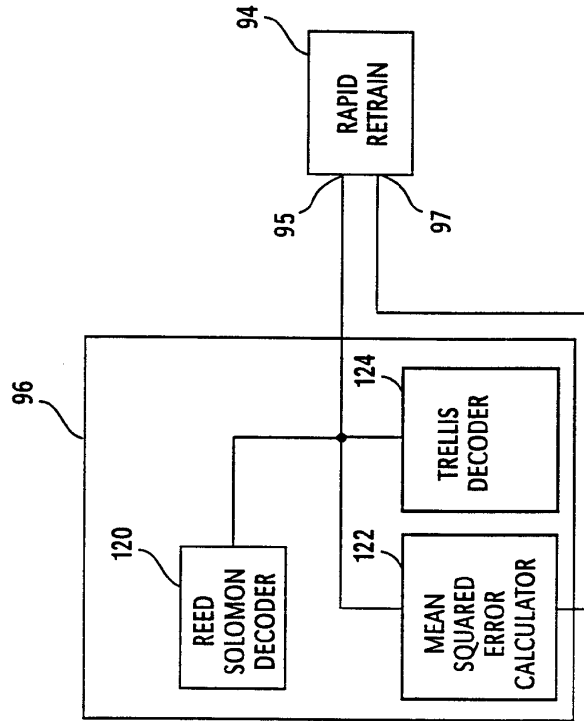

FIG. 4

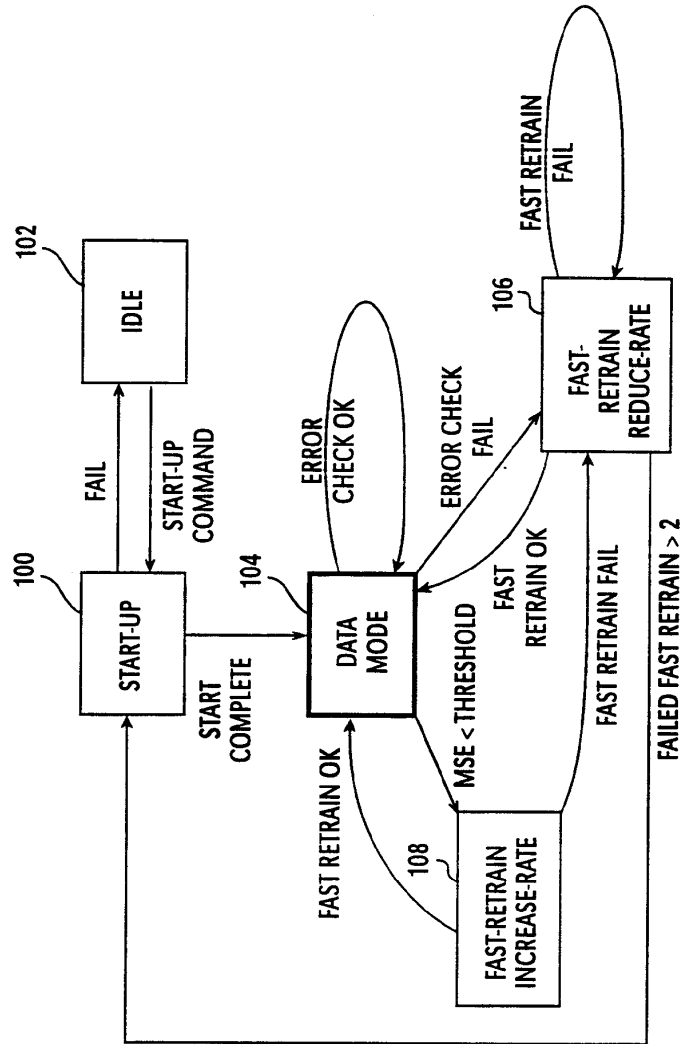

FIG. 5

INTERNATIONAL SEARCH REPORT

International Application No
PCT/US 98/12735

A. CLASSIFICATION OF SUBJECT MATTER IPC 6 H04L27/00 H04M11/06 H04L1/12		
According to International Patent Classification (IPC) or to both national classification and IPC		
B. FIELDS SEARCHED Minimum documentation searched (classification system followed by classification symbols) IPC 6 H04L H04M		
Documentation searched other than minimum documentation to the extent that such documents are included in the fields searched		
Electronic data base consulted during the international search (name of data base and, where practical, search terms used)		
C. DOCUMENTS CONSIDERED TO BE RELEVANT		
Category *	Citation of document, with indication, where appropriate, of the relevant passages	Relevant to claim No.
X	WO 97 20396 A (ANALOG DEVICES INC) 5 June 1997 see abstract see page 5, line 5-31 see page 7, line 11-23	1-6, 20-26, 29
A	--- see claims 1-3	7-19, 27, 28
P, X	EP 0 820 168 A (TEXAS INSTRUMENTS INC) 21 January 1998 see abstract see page 4, line 40 - page 6, line 20 see page 7, line 1-17 see figure 2A	1-29
E	--- WO 98 27665 A (PARADYNE CORP) 25 June 1998 see the whole document -----	1-29
<input type="checkbox"/> Further documents are listed in the continuation of box C.		
<input checked="" type="checkbox"/> Patent family members are listed in annex.		
* Special categories of cited documents :		
"A" document defining the general state of the art which is not considered to be of particular relevance "E" earlier document but published on or after the international filing date "L" document which may throw doubts on priority claim(s) or which is cited to establish the publication date of another citation or other special reason (as specified) "O" document referring to an oral disclosure, use, exhibition or other means "P" document published prior to the international filing date but later than the priority date claimed	"T" later document published after the international filing date or priority date and not in conflict with the application but cited to understand the principle or theory underlying the invention "X" document of particular relevance; the claimed invention cannot be considered novel or cannot be considered to involve an inventive step when the document is taken alone "Y" document of particular relevance; the claimed invention cannot be considered to involve an inventive step when the document is combined with one or more other such documents, such combination being obvious to a person skilled in the art. "&" document member of the same patent family	
Date of the actual completion of the international search <p align="center">19 January 1999</p>	Date of mailing of the international search report <p align="center">26/01/1999</p>	
Name and mailing address of the ISA European Patent Office, P.B. 5818 Patentlaan 2 NL - 2280 HV Rijswijk Tel. (+31-70) 340-2040, Tx. 31 651 epo nl, Fax: (+31-70) 340-3016	Authorized officer <p align="center">Toumpoulidis, T</p>	

Form PCT/ISA/210 (second sheet) (July 1992)

INTERNATIONAL SEARCH REPORT

Information on patent family members

International Application No
PCT/US 98/12735

Patent document cited in search report	Publication date	Patent family member(s)	Publication date
WO 9720396 A	05-06-1997	US 5757803 A AU 1079797 A EP 0864219 A	26-05-1998 19-06-1997 16-09-1998
EP 0820168 A	21-01-1998	JP 10154949 A	09-06-1998
WO 9827665 A	25-06-1998	NONE	

Electronic Acknowledgement Receipt

EFS ID:	13162556
Application Number:	13476310
International Application Number:	
Confirmation Number:	7896
Title of Invention:	Multicarrier Modulation Messaging for Power Level Per Subchannel Information
First Named Inventor/Applicant Name:	David M. Krinsky
Customer Number:	62574
Filer:	Jason Vick/Joanne Vos
Filer Authorized By:	Jason Vick
Attorney Docket Number:	5550-2-CON2-1-4
Receipt Date:	02-JUL-2012
Filing Date:	21-MAY-2012
Time Stamp:	17:31:10
Application Type:	Utility under 35 USC 111(a)

Payment information:

Submitted with Payment	no
------------------------	----

File Listing:

Document Number	Document Description	File Name	File Size(Bytes)/ Message Digest	Multi Part /.zip	Pages (if appl.)
1		IDS_02.pdf	340372 4ae24f3f28b7b034dee7fd385aae600ed7a5765a	yes	4

Multipart Description/PDF files in .zip description					
Document Description			Start	End	
Transmittal Letter			1	3	
Information Disclosure Statement (IDS) Form (SB08)			4	4	
Warnings:					
Information:					
2	Foreign Reference	JP60206346.pdf	284067	no	5
			0263a567fbab65e885c27ff61f78a54915b4bfb1		
Warnings:					
Information:					
3	Foreign Reference	WO9918701A1.pdf	1641324	no	43
			11d84995b5d6f7149d3b8d208b5b6cb7bedf3ee1		
Warnings:					
Information:					
4	Non Patent Literature	5550-2-PJP-DIV-2_OA_06-04-2012.pdf	89229	no	4
			ebf4dd376bae19afb23a769f477c5caf18d9961		
Warnings:					
Information:					
Total Files Size (in bytes):			2354992		
<p>This Acknowledgement Receipt evidences receipt on the noted date by the USPTO of the indicated documents, characterized by the applicant, and including page counts, where applicable. It serves as evidence of receipt similar to a Post Card, as described in MPEP 503.</p> <p><u>New Applications Under 35 U.S.C. 111</u> If a new application is being filed and the application includes the necessary components for a filing date (see 37 CFR 1.53(b)-(d) and MPEP 506), a Filing Receipt (37 CFR 1.54) will be issued in due course and the date shown on this Acknowledgement Receipt will establish the filing date of the application.</p> <p><u>National Stage of an International Application under 35 U.S.C. 371</u> If a timely submission to enter the national stage of an international application is compliant with the conditions of 35 U.S.C. 371 and other applicable requirements a Form PCT/DO/EO/903 indicating acceptance of the application as a national stage submission under 35 U.S.C. 371 will be issued in addition to the Filing Receipt, in due course.</p> <p><u>New International Application Filed with the USPTO as a Receiving Office</u> If a new international application is being filed and the international application includes the necessary components for an international filing date (see PCT Article 11 and MPEP 1810), a Notification of the International Application Number and of the International Filing Date (Form PCT/RO/105) will be issued in due course, subject to prescriptions concerning national security, and the date shown on this Acknowledgement Receipt will establish the international filing date of the application.</p>					

IN THE UNITED STATES PATENT AND TRADEMARK OFFICE

In Re the Application of:)	Group Art Unit: 2611
David M. Krinsky et al.)	Confirmation No.: 7896
Serial No.: 13/476,310)	Examiner:
Filed: May 21, 2012)	
Atty. File No.: 5550-2-CON2-1-4)	
Entitled: "MULTICARRIER MODULATION MESSAGING FOR POWER LEVEL PER SUBCHANNEL INFORMATION")	<u>SUPPLEMENTAL</u> <u>INFORMATION DISCLOSURE</u> <u>STATEMENT</u>
)	Electronically Submitted

Commissioner for Patents
P.O. Box 1450
Alexandria, VA 22313-1450

Dear Sir:

The references cited on attached Form PTO-1449 are being called to the attention of the Examiner.

- Copies of the cited non-patent and/or foreign references are enclosed herewith.
- Copies of the cited U.S. patents and/or patent applications are enclosed herewith.
- Copies of the cited U.S. patents/patent application publications are not enclosed in accordance with 37 C.F.R. § 1.98(a).
- Copies of the cited references are not enclosed, in accordance with 37 C.F.R. § 1.98(d), because the references were cited by or submitted to the U.S. Patent and Trademark Office in prior application Serial No. _____ filed _____, which is relied upon for an earlier filing date under 35 U.S.C. § 120.
- To the best of applicants' belief, the pertinence of the foreign-language references are believed to be summarized in the attached English translation/abstracts and/or in the figures, although applicants do not necessarily vouch for the accuracy of the translation.
- Examiner's attention is drawn to the following related applications:
 - Serial No. _____ filed _____, (Attorney's Ref. No. _____)
- Other: _____

Submission of the above information is not intended as an admission that any item is citable under the statutes or rules to support a rejection, that any item disclosed represents analogous art, or that those skilled in the art would refer to or recognize the pertinence of any reference without the benefit of hindsight, nor should an inference be drawn as to the pertinence of the references based on the order in which they are presented.

Submission of this statement should not be taken as an indication that a search has been conducted, or that no better art exists.

It is respectfully requested that the cited information be expressly considered during the prosecution of this application and the references made of record therein.

FEES

<input checked="" type="checkbox"/>	<p>37 CFR 1.97(b): No fee is believed due in connection with this submission, because the information disclosure statement submitted herewith is satisfied by one of the following conditions ("X" indicates satisfaction):</p> <p><input type="checkbox"/> Within three months of the filing date of a national application other than a continued prosecution application under 37 CFR 1.53(d), or</p> <p><input type="checkbox"/> Within three months of the date of entry into the national stage of an international application as set forth in 37 CFR 1.491 or</p> <p><input checked="" type="checkbox"/> Before the mailing date of a first Office Action on the merits, or</p> <p><input type="checkbox"/> Before the mailing of a first Office action after the filing of a request for continued examination under 37 CFR 1.114.</p> <p>Although no fee is believed due, if any fee is deemed due in connection with this submission, please charge such fee to Deposit Account 19-1970.</p>
<input type="checkbox"/>	<p>37 CFR 1.97(e): The information disclosure statement transmitted herewith is being filed after all the above conditions (37 CFR 1.97(b)), but before the mailing date of one of the following conditions:</p> <p>(1) a final action under 37 C.F.R. 1.113 or</p> <p>(2) a notice of allowance under 37 C.F.R. 1.311, or</p> <p>(3) an action that otherwise closes prosecution in the application.</p> <p>This Information Disclosure Statement is accompanied by:</p> <p><input type="checkbox"/> A Certification (below) as specified by 37 C.F.R. 1.97(e). Although no fee is believed due, if any fee is deemed due in connection with this submission, please charge such fee to Deposit Account 19-1970.</p> <p style="text-align: center;">OR</p> <p><input type="checkbox"/> Please charge Deposit Account 19-1970 in the amount of \$180.00 for the fee set forth in 37 C.F.R. 1.17(p) for submission of an information disclosure statement. Please credit any overpayment or charge any underpayment to Deposit Account 19-1970.</p>
<input type="checkbox"/>	<p>37 CFR 1.97(d): This Information Disclosure Statement is being submitted after the period specified in 37 CFR 1.97(c).</p> <p><input type="checkbox"/> This information Disclosure Statement includes a Certification (below) as specified by 37 C.F.R. 1.97(e)</p> <p style="text-align: center;">AND</p> <p><input type="checkbox"/> Applicants hereby requests consideration of the reference(s) disclosed herein. Please charge Deposit Account 19-1970 in the amount of \$180.00 under 37 C.F.R. 1.17(p). Please credit any overpayment or charge any underpayment to Deposit Account 19-1970. Election to pay the fee should not be taken as an indication that applicant(s) cannot execute a certification.</p>

Certification (37 C.F.R. 1.97(e))
(Applicable only if checked)

- The undersigned certifies that:
- Each item of information contained in this information disclosure statement was first cited in any communication from a foreign patent office in a counterpart foreign application not more than three months prior to the filing of this statement. 37 C.F.R. 1.97(e)(1).
 - A copy of the communication from the foreign patent office is enclosed.

OR

- No item of information contained in this information disclosure statement was cited in a communication from a foreign patent office in a counterpart foreign application, and, to the knowledge of the undersigned after making reasonable inquiry, no item of information contained in this Information Disclosure Statement was known to any individual designated in 37 C.F.R. 1.56(c) more than three months prior to the filing of this statement. 37 C.F.R. 1.97(e)(2).

Respectfully submitted,

SHERIDAN ROSS P.C.

By: _____

Jason H. Vick
Registration No. 45,285
1560 Broadway, Suite 1200
Denver, Colorado 80202-5141
(303) 863-9700

Date: 2 July '12



UNITED STATES PATENT AND TRADEMARK OFFICE

UNITED STATES DEPARTMENT OF COMMERCE
United States Patent and Trademark Office
Address: COMMISSIONER FOR PATENTS
PO Box 1450
Alexandria, Virginia 22313-1450
www.uspto.gov

Table with 7 columns: APPLICATION NUMBER, FILING or 371(c) DATE, GRP ART UNIT, FIL FEE REC'D, ATTY. DOCKET NO, TOT CLAIMS, IND CLAIMS. Row 1: 13/476,310, 05/21/2012, 2614, 1750, 5550-2-CON2-1-4, 9, 5

CONFIRMATION NO. 7896

FILING RECEIPT



62574
Jason H. Vick
Sheridan Ross, PC
Suite # 1200
1560 Broadway
Denver, CO 80202

Date Mailed: 06/06/2012

Receipt is acknowledged of this non-provisional patent application. The application will be taken up for examination in due course. Applicant will be notified as to the results of the examination. Any correspondence concerning the application must include the following identification information: the U.S. APPLICATION NUMBER, FILING DATE, NAME OF APPLICANT, and TITLE OF INVENTION. Fees transmitted by check or draft are subject to collection. Please verify the accuracy of the data presented on this receipt. If an error is noted on this Filing Receipt, please submit a written request for a Filing Receipt Correction. Please provide a copy of this Filing Receipt with the changes noted thereon. If you received a "Notice to File Missing Parts" for this application, please submit any corrections to this Filing Receipt with your reply to the Notice. When the USPTO processes the reply to the Notice, the USPTO will generate another Filing Receipt incorporating the requested corrections

Applicant(s)

David M. Krinsky, Acton, MA;
Robert Edmund Pizzano JR., Stoneham, MA;

Assignment For Published Patent Application

AWARE, INC., Bedford, MA

Power of Attorney: The patent practitioners associated with Customer Number 62574

Domestic Priority data as claimed by applicant

This application is a CON of 12/779,660 05/13/2010
which is a CON of 12/477,742 06/03/2009 PAT 7835430
which is a CON of 10/619,691 07/16/2003 PAT 7570686
which is a CON of 09/755,173 01/08/2001 PAT 6658052
which claims benefit of 60/224,308 08/10/2000
and claims benefit of 60/174,865 01/07/2000

Foreign Applications (You may be eligible to benefit from the Patent Prosecution Highway program at the USPTO. Please see http://www.uspto.gov for more information.)

If Required, Foreign Filing License Granted: 05/31/2012

The country code and number of your priority application, to be used for filing abroad under the Paris Convention, is US 13/476,310

Projected Publication Date: 09/13/2012

Non-Publication Request: No

Early Publication Request: No

Title

Multicarrier Modulation Messaging for Power Level Per Subchannel Information

Preliminary Class

379

PROTECTING YOUR INVENTION OUTSIDE THE UNITED STATES

Since the rights granted by a U.S. patent extend only throughout the territory of the United States and have no effect in a foreign country, an inventor who wishes patent protection in another country must apply for a patent in a specific country or in regional patent offices. Applicants may wish to consider the filing of an international application under the Patent Cooperation Treaty (PCT). An international (PCT) application generally has the same effect as a regular national patent application in each PCT-member country. The PCT process **simplifies** the filing of patent applications on the same invention in member countries, but **does not result** in a grant of "an international patent" and does not eliminate the need of applicants to file additional documents and fees in countries where patent protection is desired.

Almost every country has its own patent law, and a person desiring a patent in a particular country must make an application for patent in that country in accordance with its particular laws. Since the laws of many countries differ in various respects from the patent law of the United States, applicants are advised to seek guidance from specific foreign countries to ensure that patent rights are not lost prematurely.

Applicants also are advised that in the case of inventions made in the United States, the Director of the USPTO must issue a license before applicants can apply for a patent in a foreign country. The filing of a U.S. patent application serves as a request for a foreign filing license. The application's filing receipt contains further information and guidance as to the status of applicant's license for foreign filing.

Applicants may wish to consult the USPTO booklet, "General Information Concerning Patents" (specifically, the section entitled "Treaties and Foreign Patents") for more information on timeframes and deadlines for filing foreign patent applications. The guide is available either by contacting the USPTO Contact Center at 800-786-9199, or it can be viewed on the USPTO website at <http://www.uspto.gov/web/offices/pac/doc/general/index.html>.

For information on preventing theft of your intellectual property (patents, trademarks and copyrights), you may wish to consult the U.S. Government website, <http://www.stopfakes.gov>. Part of a Department of Commerce initiative, this website includes self-help "toolkits" giving innovators guidance on how to protect intellectual property in specific countries such as China, Korea and Mexico. For questions regarding patent enforcement issues, applicants may call the U.S. Government hotline at 1-866-999-HALT (1-866-999-4158).

LICENSE FOR FOREIGN FILING UNDER

Title 35, United States Code, Section 184

Title 37, Code of Federal Regulations, 5.11 & 5.15

GRANTED

The applicant has been granted a license under 35 U.S.C. 184, if the phrase "IF REQUIRED, FOREIGN FILING LICENSE GRANTED" followed by a date appears on this form. Such licenses are issued in all applications where the conditions for issuance of a license have been met, regardless of whether or not a license may be required as

set forth in 37 CFR 5.15. The scope and limitations of this license are set forth in 37 CFR 5.15(a) unless an earlier license has been issued under 37 CFR 5.15(b). The license is subject to revocation upon written notification. The date indicated is the effective date of the license, unless an earlier license of similar scope has been granted under 37 CFR 5.13 or 5.14.

This license is to be retained by the licensee and may be used at any time on or after the effective date thereof unless it is revoked. This license is automatically transferred to any related applications(s) filed under 37 CFR 1.53(d). This license is not retroactive.

The grant of a license does not in any way lessen the responsibility of a licensee for the security of the subject matter as imposed by any Government contract or the provisions of existing laws relating to espionage and the national security or the export of technical data. Licensees should apprise themselves of current regulations especially with respect to certain countries, of other agencies, particularly the Office of Defense Trade Controls, Department of State (with respect to Arms, Munitions and Implements of War (22 CFR 121-128)); the Bureau of Industry and Security, Department of Commerce (15 CFR parts 730-774); the Office of Foreign Assets Control, Department of Treasury (31 CFR Parts 500+) and the Department of Energy.

NOT GRANTED

No license under 35 U.S.C. 184 has been granted at this time, if the phrase "IF REQUIRED, FOREIGN FILING LICENSE GRANTED" DOES NOT appear on this form. Applicant may still petition for a license under 37 CFR 5.12, if a license is desired before the expiration of 6 months from the filing date of the application. If 6 months has lapsed from the filing date of this application and the licensee has not received any indication of a secrecy order under 35 U.S.C. 181, the licensee may foreign file the application pursuant to 37 CFR 5.15(b).

SelectUSA

The United States represents the largest, most dynamic marketplace in the world and is an unparalleled location for business investment, innovation and commercialization of new technologies. The USA offers tremendous resources and advantages for those who invest and manufacture goods here. Through SelectUSA, our nation works to encourage, facilitate, and accelerate business investment. To learn more about why the USA is the best country in the world to develop technology, manufacture products, and grow your business, visit SelectUSA.gov.



UNITED STATES PATENT AND TRADEMARK OFFICE

UNITED STATES DEPARTMENT OF COMMERCE
United States Patent and Trademark Office
Address: COMMISSIONER FOR PATENTS
P.O. Box 1450
Alexandria, Virginia 22313-1450
www.uspto.gov

APPLICATION NUMBER	FILING OR 371(C) DATE	FIRST NAMED APPLICANT	ATTY. DOCKET NO./TITLE
13/476,310	05/21/2012	David M. Krinsky	5550-2-CON2-1-4

CONFIRMATION NO. 7896

POA ACCEPTANCE LETTER



62574
Jason H. Vick
Sheridan Ross, PC
Suite # 1200
1560 Broadway
Denver, CO 80202

Date Mailed: 06/06/2012

NOTICE OF ACCEPTANCE OF POWER OF ATTORNEY

This is in response to the Power of Attorney filed 05/21/2012.

The Power of Attorney in this application is accepted. Correspondence in this application will be mailed to the above address as provided by 37 CFR 1.33.

/llam/

Office of Data Management, Application Assistance Unit (571) 272-4000, or (571) 272-4200, or 1-888-786-0101

PATENT APPLICATION FEE DETERMINATION RECORD Substitute for Form PTO-875						Application or Docket Number 13/476,310					
APPLICATION AS FILED - PART I											
(Column 1)			(Column 2)			SMALL ENTITY		OR	OTHER THAN SMALL ENTITY		
FOR	NUMBER FILED	NUMBER EXTRA	RATE(\$)	FEE(\$)	RATE(\$)	FEE(\$)		RATE(\$)	FEE(\$)		
BASIC FEE <small>(37 CFR 1.16(a), (b), or (c))</small>	N/A	N/A	N/A		N/A	380		N/A	620		
SEARCH FEE <small>(37 CFR 1.16(k), (l), or (m))</small>	N/A	N/A	N/A		N/A	250		N/A	250		
EXAMINATION FEE <small>(37 CFR 1.16(o), (p), or (q))</small>	N/A	N/A	N/A		N/A	0.00	x	60	=	0.00	
TOTAL CLAIMS <small>(37 CFR 1.16(i))</small>	9	minus 20 = *			x	250	=	500		0.00	
INDEPENDENT CLAIMS <small>(37 CFR 1.16(h))</small>	5	minus 3 = *	2							0.00	
APPLICATION SIZE FEE <small>(37 CFR 1.16(s))</small>	If the specification and drawings exceed 100 sheets of paper, the application size fee due is \$310 (\$155 for small entity) for each additional 50 sheets or fraction thereof. See 35 U.S.C. 41(a)(1)(G) and 37 CFR 1.16(s).									0.00	
MULTIPLE DEPENDENT CLAIM PRESENT <small>(37 CFR 1.16(j))</small>										0.00	
* If the difference in column 1 is less than zero, enter "0" in column 2.			TOTAL		TOTAL	1750					
APPLICATION AS AMENDED - PART II											
(Column 1)			(Column 2)		(Column 3)		SMALL ENTITY		OR	OTHER THAN SMALL ENTITY	
AMENDMENT A	CLAIMS REMAINING AFTER AMENDMENT	HIGHEST NUMBER PREVIOUSLY PAID FOR	PRESENT EXTRA	RATE(\$)	ADDITIONAL FEE(\$)	RATE(\$)	ADDITIONAL FEE(\$)		RATE(\$)	ADDITIONAL FEE(\$)	
	Total <small>(37 CFR 1.16(i))</small>	*	Minus **	=	x	=		x	=		
	Independent <small>(37 CFR 1.16(h))</small>	*	Minus ***	=	x	=		x	=		
	Application Size Fee <small>(37 CFR 1.16(s))</small>										
	FIRST PRESENTATION OF MULTIPLE DEPENDENT CLAIM <small>(37 CFR 1.16(j))</small>										
			TOTAL ADD'L FEE		TOTAL ADD'L FEE			TOTAL ADD'L FEE			
AMENDMENT B	CLAIMS REMAINING AFTER AMENDMENT	HIGHEST NUMBER PREVIOUSLY PAID FOR	PRESENT EXTRA	RATE(\$)	ADDITIONAL FEE(\$)	RATE(\$)	ADDITIONAL FEE(\$)		RATE(\$)	ADDITIONAL FEE(\$)	
	Total <small>(37 CFR 1.16(i))</small>	*	Minus **	=	x	=		x	=		
	Independent <small>(37 CFR 1.16(h))</small>	*	Minus ***	=	x	=		x	=		
	Application Size Fee <small>(37 CFR 1.16(s))</small>										
	FIRST PRESENTATION OF MULTIPLE DEPENDENT CLAIM <small>(37 CFR 1.16(j))</small>										
			TOTAL ADD'L FEE		TOTAL ADD'L FEE			TOTAL ADD'L FEE			
<p>* If the entry in column 1 is less than the entry in column 2, write "0" in column 3.</p> <p>** If the "Highest Number Previously Paid For" IN THIS SPACE is less than 20, enter "20".</p> <p>*** If the "Highest Number Previously Paid For" IN THIS SPACE is less than 3, enter "3".</p> <p>The "Highest Number Previously Paid For" (Total or Independent) is the highest found in the appropriate box in column 1.</p>											

IN THE UNITED STATES PATENT AND TRADEMARK OFFICE

In Re the Application of: David M. Krinsky) Group Art Unit:
Application No.:) Examiner:
Filed: Herewith) Confirmation No.:
Atty. File No.: 5550-2-CON2-1-4)

For: MULTICARRIER MODULATION MESSAGING FOR POWER LEVEL PER
SUBCHANNEL INFORMATION

Commissioner for Patents
P.O. Box 1450
Alexandria, VA 22313

PRELIMINARY AMENDMENT

Dear Madam:

Prior to the initial review of the above-identified patent application by the Examiner, please enter the following Preliminary Amendment. Although Applicants do not believe that any fees are due based upon the filing of this Preliminary Amendment, please charge any such fees to Deposit Account 19-1970.

Please amend the above-identified patent application as follows:

Amendments to the Specification begin on page 2 of this paper.

Amendments to the Claims are shown in the listing of claims which begin on page 3 of this paper.

Remarks begin on page 6 of this paper.

AMENDMENTS TO THE SPECIFICATION

Please amend the title to read as follows:

SYSTEMS AND METHODS FOR ESTABLISHING A DIAGNOSTIC TRANSMISSION
MODE AND COMMUNICATING OVER THE SAME MULTICARRIER MODULATION
MESSAGING FOR POWER LEVEL PER SUBCHANNEL INFORMATION

Please insert the following paragraph as the first paragraph beneath the title:

Related Application Data

This application is a continuation of U.S. Application No. 12/779,660, filed May 13, 2012, which is a continuation of U.S. Application No. 12/477,742, filed June 3, 2009, now U.S. Patent No. 7,835,430, which is a continuation of U.S. Application No. 10/619,691, filed July 16, 2003, now U.S. Patent No. 7,570,686, which is a continuation of U.S. Application No. 09/755,173, filed January 8, 2001, now U.S. Patent No. 6,658,052, which claims the benefit of and priority under 35 U.S.C. §119(e) to U.S. Provisional Application No. 60/224,308, filed August 10, 2000 entitled "Characterization of transmission lines using broadband signals in a multi-carrier DSL system," and U.S. Provisional Application No. 60/174,865, filed January 7, 2000 entitled "Multicarrier Modulation System with Remote Diagnostic Transmission Mode", each of which are incorporated herein by reference in their entirety.

AMENDMENTS TO THE CLAIMS

This listing of claims will replace all prior versions, and listings, of claims in the application.

Listing of Claims:

1-43. (Cancelled)

44. (New) A transceiver capable of transmitting diagnostic information over a communication channel using multicarrier modulation comprising:

a transmitter portion capable of transmitting a message, wherein the message comprises one or more data variables that represent the diagnostic information, wherein bits in the message are modulated onto DMT symbols using Quadrature Amplitude Modulation (QAM) with more than 1 bit per subchannel and wherein at least one data variable of the one or more data variables comprises an array representing power level per subchannel information.

45. (New) The transceiver of claim 44, wherein the power level per subchannel information is based on a Reverb signal.

46. (New) A transceiver capable of receiving diagnostic information over a communication channel using multicarrier modulation comprising:

a receiver portion capable of receiving a message, wherein the message comprises one or more data variables that represent the diagnostic information, wherein bits in the message were modulated onto DMT symbols using Quadrature Amplitude Modulation (QAM) with more than 1 bit per subchannel and wherein at least one data variable of the one or more data variables comprises an array representing power level per subchannel information.

47. (New) The transceiver of claim 46, wherein the power level per subchannel information is based on a Reverb signal.

48. (New) In a transceiver capable of transmitting diagnostic information over a communication channel using multicarrier modulation, a method comprising:

transmitting a message, wherein the message comprises one or more data variables that represent the diagnostic information, wherein bits in the message are modulated onto DMT symbols using Quadrature Amplitude Modulation (QAM) with more than 1 bit per subchannel and wherein at least one data variable of the one or more data variables comprises an array representing power level per subchannel information.

49. (New) The method of claim 48, wherein the power level per subchannel information is based on a Reverb signal.

50. (New) In a transceiver capable of receiving diagnostic information over a communication channel using multicarrier modulation, a method comprising:

receiving a message, wherein the message comprises one or more data variables that represent the diagnostic information, wherein bits in the message were modulated onto DMT symbols using Quadrature Amplitude Modulation (QAM) with more than 1 bit per subchannel and wherein at least one data variable of the one or more data variables comprises an array representing power level per subchannel information.

51. (New) The method of claim 50, wherein the power level per subchannel information is based on a Reverb signal.

52. (New) A communications system for DSL service comprising a first DSL transceiver capable of transmitting diagnostic information over a communication channel using multicarrier modulation and a second DSL transceiver capable of receiving the diagnostic information over the communication channel using multicarrier modulation comprising:

a transmitter portion of the first transceiver capable of transmitting a message, wherein the message comprises one or more data variables that represent the diagnostic information, wherein bits in the message are modulated onto DMT symbols using Quadrature Amplitude Modulation (QAM) with more than 1 bit per subchannel and wherein at least one data variable of the one or more data variables comprises an array representing Signal to Noise ratio per subchannel during Showtime information; and

a receiver portion of the second transceiver capable of receiving the message, wherein the message comprises the one or more data variables that represent the diagnostic information, wherein the bits in the message were modulated onto the DMT symbols using Quadrature Amplitude Modulation (QAM) with more than 1 bit per subchannel and wherein the at least one data variable of the one or more data variables comprises the array representing Signal to Noise ratio per subchannel during Showtime information.

REMARKS/ARGUMENTS

By this amendment, claims 1-43 are canceled without prejudice or disclaimer and new claims 44-52 have been added.

Applicant requests examination on the merits.

Applicant believes that the pending claims are in condition for allowance and such disposition is respectfully requested. In the event that a telephone conversation would further prosecution and/or expedite allowance, the Examiner is invited to contact the undersigned.

The Commissioner is hereby authorized to charge to Deposit Account No. 19-1970 any fees under 37 C.F.R. §§ 1.16 and 1.17 that may be required by this paper and to credit any overpayment to that Account. If any extension of time is required in connection with the filing of this paper and has not been separately requested, such extension is hereby Petitioned.

Respectfully submitted,

SHERIDAN ROSS P.C.

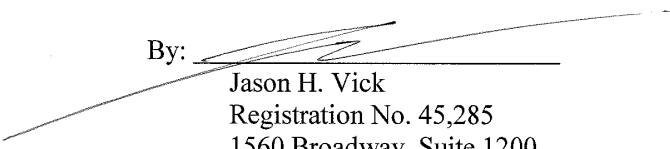
By: 
Jason H. Vick
Registration No. 45,285
1560 Broadway, Suite 1200
Denver, Colorado 80202-5141
(303) 863-9700

Date: 22 MAY '12

**SYSTEMS AND METHODS FOR ESTABLISHING A DIAGNOSTIC
TRANSMISSION MODE AND COMMUNICATING OVER THE SAME**

5 **Field of the Invention**

This invention relates to test and diagnostic information. In particular, this invention relates to a robust system and method for communicating diagnostic information.

Background of the Invention

10 The exchange of diagnostic and test information between transceivers in a telecommunications environment is an important part of a telecommunications, such as an ADSL, deployment. In cases where the transceiver connection is not performing as expected, for example, where the data rate is low, where there are many bit errors, or the like, it is necessary to collect diagnostic and test information from the remote transceiver. This is
15 performed by dispatching a technician to the remote site, e.g., a truck roll, which is time consuming and expensive.

In DSL technology, communications over a local subscriber loop between a central office and a subscriber premises is accomplished by modulating the data to be transmitted onto a multiplicity of discrete frequency carriers which are summed together and then
20 transmitted over the subscriber loop. Individually, the carriers form discrete, non-overlapping communication subchannels of limited bandwidth. Collectively, the carriers form what is effectively a broadband communications channel. At the receiver end, the carriers are demodulated and the data recovered.

DSL systems experience disturbances from other data services on adjacent phone
25 lines, such as, for example, ADSL, HDSL, ISDN, T1, or the like. These disturbances may commence after the subject ADSL service is already initiated and, since DSL for internet access is envisioned as an always-on service, the effect of these disturbances must be ameliorated by the subject ADSL transceiver.

30 **SUMMARY OF THE INVENTION**

The systems and methods of this invention are directed toward reliably exchanging diagnostic and test information between transceivers over a digital subscriber line in the presence of voice communications and/or other disturbances. For simplicity of reference, the

systems and methods of the invention will hereafter refer to the transceivers generically as modems. One such modem is typically located at a customer premises such as a home or business and is “downstream” from a central office with which it communicates. The other modem is typically located at the central office and is “upstream” from the customer
5 premises. Consistent with industry practice, the modems are often referred to as “ATU-R” (“ADSL transceiver unit, remote,” i.e., located at the customer premises) and “ATU-C” (“ADSL transceiver unit, central office” i.e., located at the central office). Each modem includes a transmitter section for transmitting data and a receiver section for receiving data, and is of the discrete multitone type, i.e., the modem transmits data over a multiplicity of
10 subchannels of limited bandwidth. Typically, the upstream or ATU-C modem transmits data to the downstream or ATU-R modem over a first set of subchannels, which are usually the higher-frequency subchannels, and receives data from the downstream or ATU-R modem over a second, usually smaller, set of subchannels, commonly the lower-frequency subchannels. By establishing a diagnostic link mode between the two modems, the systems
15 and methods of this invention are able to exchange diagnostic and test information in a simple and robust manner.

In the diagnostic link mode, the diagnostic and test information is communicated using a signaling mechanism that has a very high immunity to noise and/or other disturbances and can therefore operate effectively even in the case where the modems could not actually
20 establish an acceptable connection in their normal operational mode.

For example, if the ATU-C and/or ATU-R modem fail to complete an initialization sequence, and are thus unable to enter a normal steady state communications mode, where the diagnostic and test information would normally be exchanged, the modems according to the systems and methods of this invention enter a robust diagnostic link mode. Alternatively, the
25 diagnostic link mode can be entered automatically or manually, for example, at the direction of a user. In the robust diagnostic link mode, the modems exchange the diagnostic and test information that is, for example, used by a technician to determine the cause of a failure without the technician having to physically visit, i.e., a truckroll to, the remote site to collect data.

30 The diagnostic and test information can include, for example, but is not limited to, signal to noise ratio information, equalizer information, programmable gain setting information, bit allocation information, transmitted and received power information, margin information, status and rate information, telephone line condition information, such as the length of the line, the number and location of bridged taps, a wire gauge, or the like, or any

other known or later developed diagnostic or test information that may be appropriate for the particular communications environment. For example, the exchanged diagnostic and test information can be directed toward specific limitations of the modems, to information relating to the modem installation and deployment environment, or to other diagnostic and test information that can, for example, be determined as needed which may aid in evaluating the cause of a specific failure or problem. Alternatively, the diagnostic and test information can include the loop length and bridged tap length estimations as discussed in copending Attorney Docket No. 081513-000003, filed herewith and incorporated herein by reference in its entirety.

10 For example, an exemplary embodiment of the invention illustrates the use of the diagnostic link mode in the communication of diagnostic information from the remote terminal (RT) transceiver, e.g., ATU-R, to the central office (CO) transceiver, e.g., ATU-C. Transmission of information from the remote terminal to the central office is important since a typical ADSL service provider is located in the central office and would therefore benefit from the ability to determine problems at the remote terminal without a truckroll. However, it is to be appreciated, that the systems and the methods of this invention will work equally well in communications from the central office to the remote terminal.

These and other features and advantages of this invention are described in or are apparent from the following detailed description of the embodiments.

20

BRIEF DESCRIPTION OF THE DRAWINGS

The embodiments of the invention will be described in detail, with reference to the following figures wherein:

Fig. 1 is a functional block diagram illustrating an exemplary communications system according to this invention; and

Fig. 2 is a flowchart outlining an exemplary method for communicating diagnostic and test information according to this invention.

DETAILED DESCRIPTION OF THE INVENTION

30 For ease of illustration the following description will be described in relation to the CO receiving diagnostic and test information from the RT. In the exemplary embodiment, the systems and methods of this invention complete a portion of the normal modem initialization before entering into the diagnostic link mode. The systems and methods of this invention can enter the diagnostic link mode manually, for example, at the direction of a

technician or a user after completing a portion of initialization. Alternatively, the systems and methods of this invention can enter the diagnostic link mode automatically based on, for example, a bit rate failure, a forward error correction or a CRC error during showtime, e.g., the normal steady state transmission mode, or the like. The transition into the diagnostic link mode is accomplished by transmitting a message from the CO modem to the RT modem indicating that the modems are to enter into the diagnostic link mode, as opposed to transitioning into the normal steady state data transmission mode. Alternatively, the transition into the diagnostic link mode is accomplished by transmitting a message from the RT modem to the CO modem indicating that the modems are to enter into the diagnostic link mode as opposed to transitioning into the normal steady state data transmission mode. For example, the transition signal uses an ADSL state transition to transition from a standard ADSL state to a diagnostic link mode state.

In the diagnostic link mode, the RT modem sends diagnostic and test information in the form of a collection of information bits to the CO modem that are, for example, modulated by using one bit per DTM symbol modulation, as is used in the C-Rates1 message in the ITU and ANSI ADSL standards, where the symbol may or may not include a cyclic prefix. Other exemplary modulation techniques include Differential Phase Shift Keying (DPSK) on a subset or all the carriers, as specified in, for example, ITU standard G.994.1, higher order QAM modulation (>1 bit per carrier), or the like.

In the one bit per DMT symbol modulation message encoding scheme, a bit with value 0 is mapped to the REVERB1 signal and a bit with a value of 1 mapped to a SEGUE1 signal. The REVERB1 and SEGUE1 signals are defined in the ITU and ANSI ADSL standards. The REVERB1 signal is generated by modulating all of the carriers in the multicarrier system with a known pseudo-random sequence thus generating a wideband modulated signal. The SEGUE1 signal is generated from a carrier by 180 degree phase reversal of the REVERB1 signal. Since both signals are wideband and known in advance, the receiver can easily detect the REVERB1 and SEGUE1 signal using a simple matched filter in the presence of large amounts of noise and other disturbances.

30

35

Exemplary Message Variables
Data Sent in the Diag Link
Train Type
ADSL Standard
Chip Type
Vendor ID
Code Version
Average Reverb Received Signal
Programmable gain amplifier (PGA) Gain – Training
Programmable gain amplifier PGA Gain – Showtime
Filter Present during Idle Channel Calculation
Average Idle Channel Noise
Signal to Noise during Training
Signal to Noise during Showtime
Bits and Gains
Data Rate
Framing Mode
Margin
Reed-Solomon Coding Gain
QAM Usage
Frequency Domain Equalizer (FDQ) Coefficients
Gain Scale
Time domain equalizer (TDQ) Coefficients
Digital Echo Canceller (DEC) Coefficients

5

Table 1

Table 1 shows an example of a data message that can be sent by the RT to the CO during the diagnostic link mode. In this example, the RT modem sends 23 different data variables to the CO. Each data variable contains different items of diagnostic and test information that are used to analyze the condition of the link. The variables may contain more than one item of data. For example, the *Average Reverb Signal* contains the power levels per tone, up to, for example, 256 entries, detected during the ADSL Reverb signal. Conversely, the *PGA Gain – Training* is a single entry, denoting the gain in dB at the receiver during the ADSL training.

Many variables that represent the type of diagnostic and test information that are used to analyze the condition of the link are sent from the RT modem to the CO modem. These variables can be, for example, arrays with different lengths depending on, for example, information in the initiate diagnostic mode message. The systems and methods of this invention can be tailored to contain many different diagnostic and test information variables.

Thus, the system is fully configurable, allowing subsets of data to be sent and additional data variables to be added in the future. Therefore, the message length can be increased or decreased, and diagnostic and test information customized, to support more or less variables as, for example, hardware, the environment and/or the telecommunications equipment dictates.

Therefore, it is to be appreciated, that in general the variables transmitted from the modem being tested to the receiving modem can be any combination of variables which allow for transmission of test and/or diagnostic information.

Fig. 1 illustrates an exemplary embodiment of the additional modem components associated with the diagnostic link mode. In particular, the diagnostic link system 100 comprises a central office modem 200 and a remote terminal modem 300. The central office modem 200 comprises, in addition to the standard ATU-C components, a CRC checker 210, a diagnostic device 220, and a diagnostic information monitoring device 230. The remote terminal modem 300 comprises, in addition to the standard components associated with an ATU-R, a message determination device 310, a power control device 320, a diagnostic device 330 and a diagnostic information storage device 340. The central office modem 200 and the remote terminal model 300 are also connected, via link 5, to a splitter 10 for a phone switch 20, and a splitter 30 for a phone 40. Alternatively, the ATU-R can operate without a splitter, e.g., splitterless, as specified in ITU standard G.992.2 (G.lite) or with an in-line filter in series with the phone 40. In addition, the remote terminal modem 300, can also be connected to, for example, one or more user terminals 60. Additionally, the central office modem 200 can be connected to one or more distributed networks 50, via link 5, which may or may not also be connected to one or more other distributed networks.

While the exemplary embodiment illustrated in Fig. 1 shows the diagnostic link system 100 for an embodiment in which the remote terminal modem 300 is communicating test and diagnostic information to the central office 200, it is to be appreciated that the various components of the diagnostic link system can be rearranged such that the diagnostic and test information can be forwarded from the central office 200 to the remote terminal modem 300, or, alternatively, such that both modems can send and receive diagnostic and/or test information. Furthermore, it is to be appreciated, that the components of the diagnostic link system 100 can be located at various locations within a distributed network, such as the POTS network, or other comparable telecommunications network. Thus, it should be appreciated that the components of the diagnostic link system 100 can be combined into one device for respectively transmitting, receiving, or transmitting and receiving diagnostic

and/or test information. As will be appreciated from the following description, and for reasons of computational efficiency, the components of the diagnostic link system 100 can be arranged at any location within a telecommunications network and/or modem without affecting the operation of the system.

5 The links 5 can be a wired or wireless link or any other known or later developed element(s) that is capable of supplying and communicating electronic data to and from the connected elements. Additionally, the user terminal 60 can be, for example, a personal computer or other device allowing a user to interface with and communicate over a modem, such as a DSL modem. Furthermore, the systems and method of this invention will work
10 equally well with splitterless and low-pass multicarrier modem technologies.

 In operation, the remote terminal 300, commences its normal initialization sequence. The diagnostic device 330 monitors the initialization sequence for a failure. If there is a failure, the diagnostic device 330 initiates the diagnostic link mode. Alternatively, a user or, for example, a technician at the CO, can specify that the remote terminal 300 enter into the
15 diagnostic link mode after completing a portion of an initialization. Alternatively still, the diagnostic device 330 can monitor the normal steady state data transmission of the remote terminal, and upon, for example, an error threshold being exceeded, the diagnostic device 330 will initiate the diagnostic link mode.

 Upon initialization of the diagnostic link mode, the diagnostic device 330, in
20 cooperation with the remote terminal 300 will transmit an initiate diagnostic link mode message from the remote terminal to the central office 200 (RT to CO). Alternatively, the central office modem 200 can transmit an initiate diagnostic link mode message to the remote terminal modem 300. If the initiate diagnostic link mode message is received by the central office 200, the diagnostic device 330, in cooperation with the message determination device
25 310, determines a diagnostic link message to be forwarded to the central office 200. For example, the diagnostic link message can include test information that has been assembled during, for example, the normal ADSL initialization procedure. The diagnostic and/or test information can include, but is not limited to, the version number of the diagnostic link mode, the length of the diagnostic and/or test information, the communications standard, such as the
30 ADSL standard, the chipset type, the vendor identifications, the ATU version number, the time domain received reverb signal, the frequency domain reverb signal, the amplifier settings, the CO transmitter power spectral density, the frequency domain received idle channel, the signal to noise ratio, the bits and gains and the upstream and downstream transmission rates, or the like.

If the initiate diagnostic link mode message is not received by the central office 200, the initiate diagnostic link mode message can, for example, be re-transmitted a predetermined number of iterations until a determination is made that it is not possible to establish a connection.

5 Assuming the initiate diagnostic link mode message is received, then, for a predetermined number of iterations, the diagnostic device 330, in cooperation with the remote terminal modem 300 and the diagnostic information storage device 340, transmits the diagnostic link message with a cyclic redundancy check (CRC) to the central office modem 200. However, it is to be appreciated that in general, any error detection scheme, such as bit error detection, can be used without affecting the operation of the system. The central office 10 200, in cooperation with the CRC checker 210, determines if the CRC is correct. If the CRC is correct, the diagnostic information stored in the diagnostic information storage device 340 has been, with the cooperation of the diagnostic device 330, and the remote terminal modem 300, forwarded to the central office 200 successfully.

15 If, for example, the CRC checker 210 is unable to determine the correct CRC, the diagnostic device 330, in cooperation with power control device 320, increases the transmission power of the remote terminal 300 and repeats the transmission of the diagnostic link message from the remote terminal 300 to the central office 200. This process continues until the correct CRC is determined by the CRC checker 210.

20 The maximum power level used for transmission of the diagnostic link message can be specified by, for example, the user or the ADSL service operator. If the CRC checker 210 does not determine a correct CRC at the maximum power level and the diagnostic link mode can not be initiated then other methods for determining diagnostic information are utilized, such as dispatching a technician to the remote site, or the like.

25 Alternatively, the remote terminal 300, with or without an increase in the power level, can transmit the diagnostic link message several times, for example, 4 times. By transmitting the diagnostic link message several times, the CO modem 200 can use, for example, a diversity combining scheme to improve the probability of obtaining a correct CRC from the received diagnostic link message(s).

30 Alternatively, as previously discussed, the central office 200 comprises a diagnostic information monitoring device 230. The remote terminal 300 can also include a diagnostic information monitoring device. One or more of these diagnostic information monitoring devices can monitor the normal steady state data transmission between the remote terminal 300 and the central office 200. Upon, for example, the normal steady state data transmission

exceeded a predetermined error threshold, the diagnostic information monitoring device can initiate the diagnostic link mode with the cooperation of the diagnostic device 300 and/or the diagnostic device 220.

Fig. 2 illustrates an exemplary method for entering a diagnostic link mode in accordance with this invention. In particular, control begins in step S100 and continues to
5 step S110. In step S110, the initialization sequence is commenced. Next, in step S120, if an initialization failure is detected, control continues to step S170. Otherwise, control jumps to step S130. In step S130, a determination is made whether the diagnostic link mode has been selected. If the diagnostic link mode has been selected, control continues to step S170,
10 otherwise, control jumps to step S140.

In step S170, the initiate diagnostic link mode message is transmitted from, for example, the remote terminal to the central office. Next, in step S180, a determination is made whether the initiate diagnostic mode message has been received by the CO. If the initiate diagnostic mode message has been received by the CO, control jumps to step S200.
15 Otherwise, control continues to step S190. In step S190, a determination is made whether to re-transmit the initiate diagnostic mode message, for example, based on whether a predetermined number of iterations have already been completed. If the initiate diagnostic mode message is to be re-transmitted, control continues back to step S170. Otherwise, control jumps to step S160.

In step S200, the diagnostic link message is determined, for example, by assembling
20 test and diagnostic information about one or more of the local loop, the modem itself, the telephone network at the remote terminal, or the like. Next, in step S210, for a predetermined number of iterations, steps S220-S240 are completed. In particular, in step S220 a diagnostic link message comprising a CRC is transmitted to, for example, the CO. Next, in step S230,
25 the CRC is determined. Then, in step S240, a determination is made whether the CRC is correct. If the CRC is correct, the test and/or diagnostic information has been successfully communicated and control continues to step S160.

Otherwise, if step S210 has completed the predetermined number of iterations, control continues to step S250. In step S250, the transmission power is increased and control
30 continues back to step S210. Alternatively, as previously discussed, the diagnostic link message may be transmitted a predetermined number of times, with or without a change in the transmission power.

In step S140, the normal steady state data transmission is entered into between two modems, such as the remote terminal and the central office modems. Next, in step S150, a

determination is made whether an error threshold during the normal steady state data transmission has been exceeded. If the error threshold has been exceeded, control continues to step S170. Otherwise, control jumps to step S160. In step S160, the control sequence ends.

5 As shown in Fig. 1, the diagnostic link mode system can be implemented either on a single program general purpose computer, a modem, such as a DSL modem, or a separate program general purpose computer having a communications device. However, the diagnostic link system can also be implemented on a special purpose computer, a programmed microprocessor or microcontroller and peripheral integrated circuit element, an
10 ASIC or other integrated circuit, a digital signal processor, a hardwired electronic or logic circuit such as a discrete element circuit, a programmed logic device such as a PLD, PLA, FPGA, PAL, or the like, and associated communications equipment. In general, any device capable of implementing a finite state machine that is capable of implementing the flowchart illustrated in Fig. 2 can be used to implement a diagnostic link system according to this
15 invention.

 Furthermore, the disclosed method may be readily implemented in software using object or object-oriented software development environments that provide portable source code that can be used on a variety of computer, workstation, or modem hardware platforms. Alternatively, the disclosed diagnostic link system may be implemented partially or fully in
20 hardware using standard logic circuits or a VLSI design. Other software or hardware can be used to implement the systems in accordance with this invention depending on the speed and/or efficiency requirements of the systems, the particular function, and a particular software or hardware systems or microprocessor or microcomputer systems being utilized. The diagnostic link system and methods illustrated herein however, can be readily
25 implemented in hardware and/or software using any known or later developed systems or structures, devices and/or software by those of ordinary skill in the applicable art from the functional description provided herein and with a general basic knowledge of the computer and telecommunications arts.

 Moreover, the disclosed methods can be readily implemented as software executed on
30 a programmed general purpose computer, a special purpose computer, a microprocessor, or the like. In these instances, the methods and systems of this invention can be implemented as a program embedded on a modem, such a DSL modem, as a resource residing on a personal computer, as a routine embedded in a dedicated diagnostic link system, a central office, or the like. The diagnostic link system can also be implemented by physically incorporating the

system and method into a software and/or hardware system, such as a hardware and software systems of a modem, a general purpose computer, an ADSL line testing device, or the like.

It is, therefore, apparent that there is provided in accordance with the present invention, systems and methods for transmitting a diagnostic link message. While this
5 invention has been described in conjunction with a number of embodiments, it is evident that many alternatives, modifications and variations would be or are apparent to those of ordinary skill in the applicable arts. Accordingly, applicants intend to embrace all such alternatives, modifications, equivalents and variations that are within the spirit and the scope of this invention.

10

What is Claimed is:

1. A diagnostic link system for communicating data between modems using multicarrier modulation comprising:
 - an initiate diagnostic mode trigger that instructs a transmitting modem to
 - 5 forward an initiate diagnostic mode message to a receiving modem;
 - a message determination device that determines a diagnostic link message; and
 - a receiving modem diagnostic device that receives the diagnostic link message and determines the accuracy of the diagnostic link message.
2. The system of claim 1, further comprising a power control device that
- 10 increases a transmission power of the diagnostic link message if the received diagnostic link message is inaccurate.
3. The system of claim 1, wherein the diagnostic link message is re-transmitted a predetermined number of times.
4. The system of claim 1, wherein the diagnostic link message comprises at least
- 15 one of test and diagnostic information.
5. The system of claim 4, wherein the diagnostic link message comprises at least one of a version number of a diagnostic link mode, a length of the diagnostic information, a communications standard, a chipset type, one or more vendor identifications, an ATU version number, a time domain received reverb signal, a frequency domain reverb signal, an amplifier
- 20 setting, a CO transmitter power spectral density, a frequency domain received idle channel, a signal to noise ratio, bits and gain information, and upstream and downstream transmission rates.
6. The system of claim 1, wherein the accuracy is determined based on at least one of an error detecting scheme, a bit error detection and a cyclic redundancy check.
- 25 7. The system of claim 1, wherein the trigger is based on at least one of an initialization failure, a bit rate failure, a CRC error in an initialization message, a CRC error during a normal steady state transmission mode, a forward error correction error, a user request, a central office modem request and a remote terminal modem request.
8. The system of claim 1, wherein the transmitting modem completes a portion
- 30 of a modem initialization sequence before forwarding the initiate diagnostic mode message.
9. The system of claim 1, wherein the transmitting modem is at least one of a central office modem and a remote terminal modem.
10. The system of claim 1, wherein the receiving modem is at least one of a central office modem and a remote terminal modem.

11. A method for communicating data between modems using multicarrier modulation comprising:

instructing a transmitting modem to forward an initiate diagnostic mode message to a receiving modem;

5 determining a diagnostic link message;

transmitting the diagnostic link message; and

determining the accuracy of the transmitted diagnostic link message.

12. The method of claim 11, further comprising increasing a transmission power of the diagnostic link message if a received diagnostic link message is inaccurate.

10 13. The method of claim 11, further comprising transmitting the diagnostic link message a predetermined number of times.

14. The method of claim 11, wherein the diagnostic link message comprises at least one of test and diagnostic information.

15 15. The method of claim 14, wherein the diagnostic link message comprises at least one of a version number of a diagnostic link mode, a length of the diagnostic information, a communications standard, a chipset type, one or more vendor identifications, an ATU version number, a time domain received reverb signal, a frequency domain reverb signal, an amplifier setting, a CO transmitter power spectral density, a frequency domain received idle channel, a signal to noise ratio, bits and gain information, and upstream and
20 downstream transmission rates.

16. The method of claim 11, wherein the accuracy is determined based on at least one of an error detecting scheme, a bit error detection and a cyclic redundancy check.

25 17. The method of claim 11, wherein the initiate diagnostic mode message is based on at least one of an initialization failure, a bit rate failure, a CRC error in an initialization message, a CRC error during the normal steady state transmission mode, a forward error correction error, a user request, a central office modem request and a remote terminal modem request.

18. The method of claim 11, further comprising completing a portion of a modem initialization sequence before forwarding the initiate diagnostic mode message.

30 19. The method of claim 11, wherein a transmitting modem is at least one of a central office modem and a remote terminal modem.

20. The method of claim 11, wherein a receiving modem is at least one of a central office modem and a remote terminal modem.

21. A method for communicating data between modems using multicarrier modulation comprising:

receiving an initiate diagnostic mode message;

determining a diagnostic link message;

5 transmitting the diagnostic link message; and

at least one of increasing a transmission power of the diagnostic link message if the received diagnostic link message is inaccurate and re-transmitting the diagnostic link message a predetermined number of times.

22. The method of claim 21, wherein the diagnostic link message comprises at least one of test and diagnostic information.

23. The method of claim 22, wherein the diagnostic link message comprises at least one of a version number of a diagnostic link mode, a length of the diagnostic information, a communications standard, a chipset type, one or more vendor identifications, an ATU version number, a time domain received reverb signal, a frequency domain reverb signal, an amplifier setting, a CO transmitter power spectral density, a frequency domain received idle channel, a signal to noise ratio, bits and gain information, and upstream and downstream transmission rates.

24. The method of claim 21, wherein the accuracy is determined based on at least one of an error detecting scheme, a bit error detection and a cyclic redundancy check.

25. The method of claim 21, wherein the initiate diagnostic mode message is based on at least one of an initialization failure, a bit rate failure, a CRC error in an initialization message, a CRC error during the normal steady state transmission mode, a forward error correction error, a user request, a central office modem request and a remote terminal modem request.

26. The method of claim 21, further comprising completing a portion of a modem initialization sequence before forwarding the initiate diagnostic mode message.

27. The method of claim 21, wherein a transmitting modem is at least one of a central office modem and a remote terminal modem.

28. The method of claim 21, wherein a receiving modem is at least one of a central office modem and a remote terminal modem.

29. A method for communicating data between modems using multicarrier modulation comprising:

receiving an initiate diagnostic mode message;

determining the accuracy of a received diagnostic link message; and

receiving at least one of an increased transmission power diagnostic link message if the received diagnostic link message is inaccurate and a re-transmission of a predetermined number of the diagnostic link messages.

30. The method of claim 29, wherein the diagnostic link message comprises at least one of test and diagnostic information.

31. The method of claim 30, wherein the received diagnostic link message comprises at least one of a version number of a diagnostic link mode, a length of the diagnostic information, a communications standard, a chipset type, one or more vendor identifications, an ATU version number, a time domain received reverb signal, a frequency domain reverb signal, an amplifier setting, a CO transmitter power spectral density, a frequency domain received idle channel, a signal to noise ratio, bits and gain information, and upstream and downstream transmission rates.

32. The method of claim 29, wherein the accuracy is determined based on at least one of an error detecting scheme, a bit error detection and a cyclic redundancy check.

33. The method of claim 29, wherein the initiate diagnostic mode message is based on at least one of an initialization failure, a bit rate failure, a CRC error in an initialization message, a CRC error during the normal steady state transmission mode, a forward error correction error, a user request, a central office modem request and a remote terminal modem request.

34. The method of claim 29, further comprising completing a portion of a modem initialization sequence before receiving the initiate diagnostic mode message.

35. An information storage media comprising information for communicating data between modems using multicarrier modulation comprising:

information that instructs a transmitting modem to forward an initiate diagnostic mode message to a receiving modem;
information that determines a diagnostic link message;
information that transmits the diagnostic link message; and
information that determines the accuracy of the transmitted diagnostic link message.

36. An information storage media comprising information for communicating data between modems using multicarrier modulation comprising:

information that receives an initiate diagnostic mode message;
information that determines a diagnostic link message;
information that transmits the diagnostic link message; and

information that at least one of increases a transmission power of the diagnostic link message if the received diagnostic link message is inaccurate and re-transmits the diagnostic link message a predetermined number of times.

37. An information storage media comprising information for communicating data
5 between modems using multicarrier modulation comprising:

information that receives an initiate diagnostic mode message;

information that determines the accuracy of a received diagnostic link
message; and

information that receives at least one of an increased transmission power
10 diagnostic link message if the received diagnostic link message is inaccurate and a re-
transmission of a predetermined number of the diagnostic link messages.

38. A method for communicating diagnostic information between DSL modems
using multicarrier modulation comprising:

completing a portion of a modem initialization sequence;

15 transmitting an initiate diagnostic communication mode message to a
receiving modem;

entering a diagnostic communications mode based on at least one of an
initialization failure, a bit rate failure, a CRC error in an initialization message, a CRC error
during the normal steady state transmission mode, a forward error correction error, a user
20 request, a central office modem request and a remote terminal modem request; and

transmitting a diagnostic link message comprising at least one of a version
number of a diagnostic link mode, a length of the diagnostic information, a communications
standard, a chipset type, one or more vendor identifications, an ATU version number, a time
domain received reverb signal, a frequency domain reverb signal, an amplifier setting, a CO
25 transmitter power spectral density, a frequency domain received idle channel, a signal to
noise ratio, bits and gain information, and upstream and downstream transmission rates.

39. The method of claim 38, further comprising re-transmitting the diagnostic link
message a predetermined number of times.

40. The method of claim 38, further comprising increasing a transmission power
30 of the diagnostic link message.

41. A method for communicating diagnostic information between DSL modems
using multicarrier modulation comprising:

completing a portion of a modem initialization sequence;

receiving an initiate diagnostic communication mode message;

entering a diagnostic communications mode based on at least one of an initialization failure, a bit rate failure, a CRC error in an initialization message, a CRC error during the normal steady state transmission mode, a forward error correction error, a user request, a central office modem request and a remote terminal modem request;

5 receiving a diagnostic link message comprising at least one of a version number of a diagnostic link mode, a length of the diagnostic information, a communications standard, a chipset type, one or more vendor identifications, an ATU version number, a time domain received reverb signal, a frequency domain reverb signal, an amplifier setting, a CO transmitter power spectral density, a frequency domain received idle channel, a signal to
10 noise ratio, bits and gain information, and upstream and downstream transmission rates.

42. The method of claim 41, further comprising receiving a re-transmitted diagnostic link message a predetermined number of times.

43. The method of claim 41, further comprising receiving an increased transmission power diagnostic link message.

15

ABSTRACT OF THE DISCLOSURE

Upon detection of a trigger, such as the exceeding of an error threshold or the direction of a user, a diagnostic link system enters a diagnostic information transmission
5 mode. This diagnostic information transmission mode allows for two modems to exchange diagnostic and/or test information that may not otherwise be exchangeable during normal communication. The diagnostic information transmission mode is initiated by transmitting an
initiate diagnostic link mode message to a receiving modem accompanied by a cyclic
redundancy check (CRC). The receiving modem determines, based on the CRC, if a robust
10 communications channel is present. If a robust communications channel is present, the two modems can initiate exchange of the diagnostic and/or test information. Otherwise, the transmission power of the transmitting modem is increased and the initiate diagnostic link mode message re-transmitted to the receiving modem until the CRC is determined to be correct.

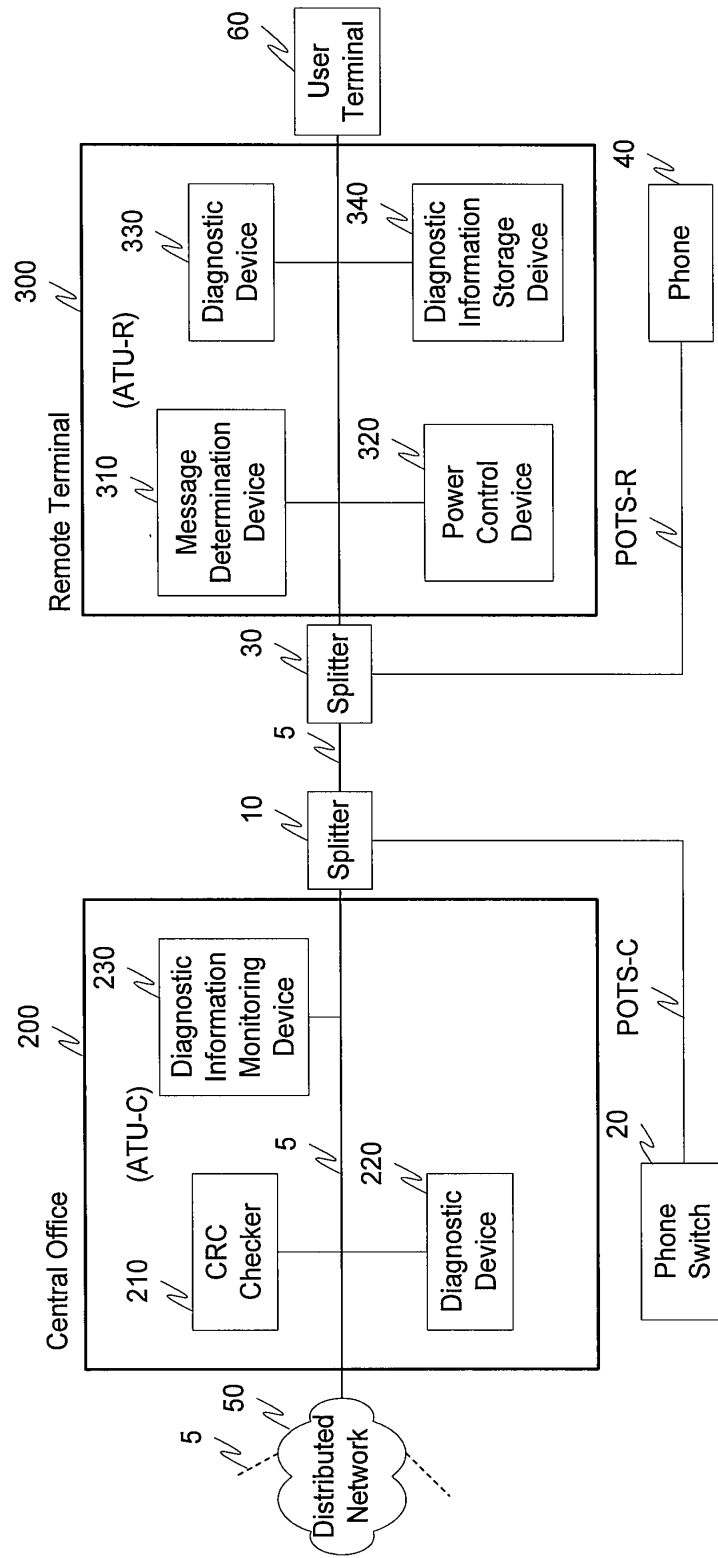

Fig. 1

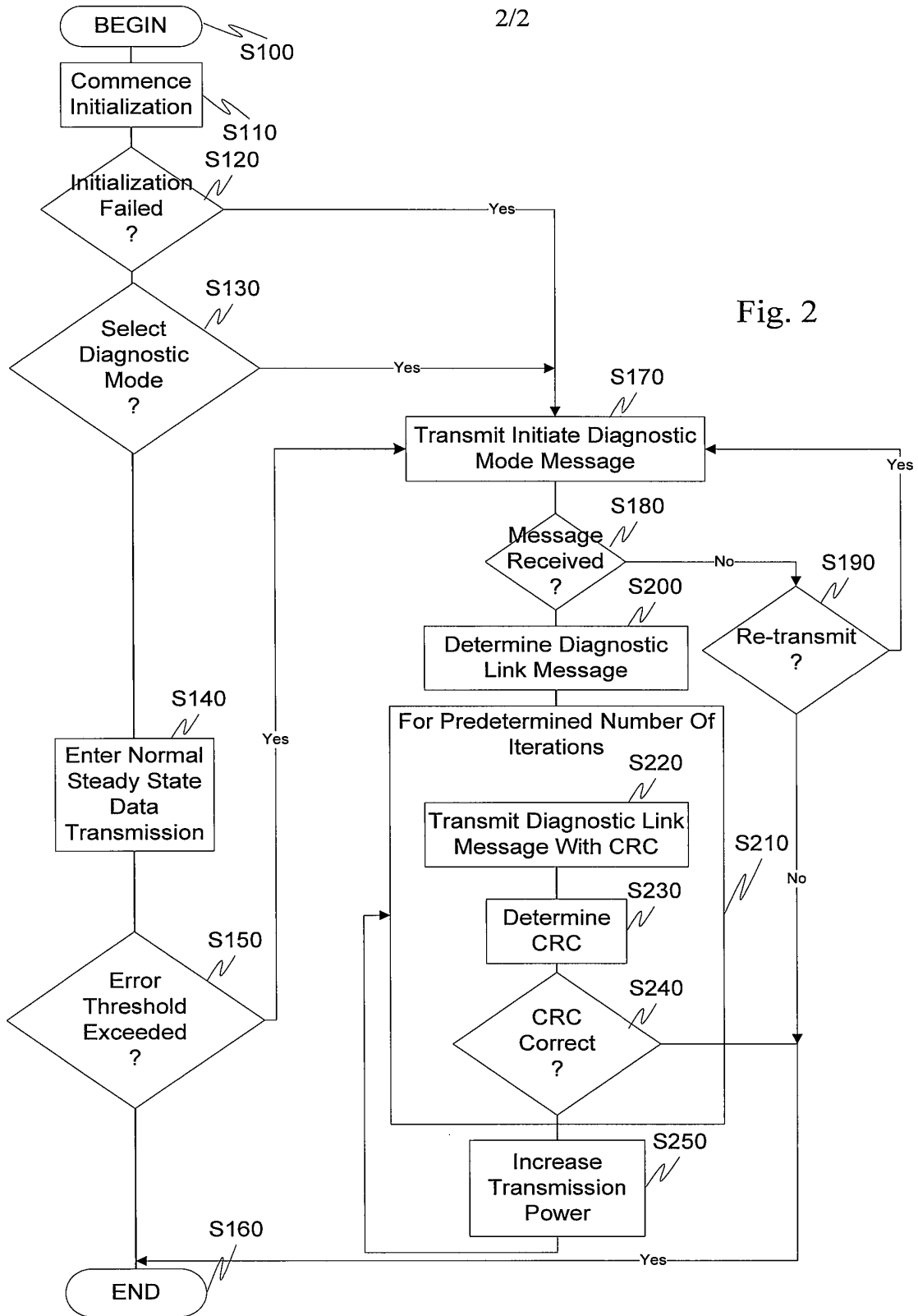

Fig. 2

Electronic Patent Application Fee Transmittal

Application Number:				
Filing Date:				
Title of Invention:	MULTICARRIER MODULATION MESSAGING FOR POWER LEVEL PER SUBCHANNEL INFORMATION			
First Named Inventor/Applicant Name:	David M. Krinsky			
Filer:	Jason Vick/Joanne Vos			
Attorney Docket Number:	5550-2-CON2-1-4			
Filed as Large Entity				
Utility under 35 USC 111(a) Filing Fees				
Description	Fee Code	Quantity	Amount	Sub-Total in USD(\$)
Basic Filing:				
Utility application filing	1011	1	380	380
Utility Search Fee	1111	1	620	620
Utility Examination Fee	1311	1	250	250
Pages:				
Claims:				
Independent claims in excess of 3	1201	2	250	500
Miscellaneous-Filing:				
Petition:				

Description	Fee Code	Quantity	Amount	Sub-Total in USD(\$)
Patent-Appeals-and-Interference:				
Post-Allowance-and-Post-Issuance:				
Extension-of-Time:				
Miscellaneous:				
Total in USD (\$)				1750

Electronic Acknowledgement Receipt

EFS ID:	12824173
Application Number:	13476310
International Application Number:	
Confirmation Number:	7896
Title of Invention:	MULTICARRIER MODULATION MESSAGING FOR POWER LEVEL PER SUBCHANNEL INFORMATION
First Named Inventor/Applicant Name:	David M. Krinsky
Customer Number:	62574
Filer:	Jason Vick/Joanne Vos
Filer Authorized By:	Jason Vick
Attorney Docket Number:	5550-2-CON2-1-4
Receipt Date:	21-MAY-2012
Filing Date:	
Time Stamp:	14:36:25
Application Type:	Utility under 35 USC 111(a)

Payment information:

Submitted with Payment	yes
Payment Type	Deposit Account
Payment was successfully received in RAM	\$ 1750
RAM confirmation Number	970
Deposit Account	191970
Authorized User	
<p>The Director of the USPTO is hereby authorized to charge indicated fees and credit any overpayment as follows:</p> <p style="padding-left: 40px;">Charge any Additional Fees required under 37 C.F.R. Section 1.16 (National application filing, search, and examination fees)</p> <p style="padding-left: 40px;">Charge any Additional Fees required under 37 C.F.R. Section 1.17 (Patent application and reexamination processing fees)</p>	

Charge any Additional Fees required under 37 C.F.R. Section 1.19 (Document supply fees)

Charge any Additional Fees required under 37 C.F.R. Section 1.21 (Miscellaneous fees and charges)

File Listing:

Document Number	Document Description	File Name	File Size(Bytes)/ Message Digest	Multi Part /.zip	Pages (if appl.)
1	Application Data Sheet	ADS.pdf	1425121 <small>3f25d4e09fd425ffa5140d4a43b438094c409cf</small>	no	5

Warnings:

Information:

2	Oath or Declaration filed	Parent_Declaration.pdf	71995 <small>2fc206abf5500fef7e8e8ac0bbf6e6a3a0ba1b5f</small>	no	2
---	---------------------------	------------------------	--	----	---

Warnings:

Information:

3		AMEND_PRELIM_01.pdf	428782 <small>5b5d65f7665ca398a255cd04f243e79dea3b0e8</small>	yes	6
---	--	---------------------	--	-----	---

Multipart Description/PDF files in .zip description

Document Description	Start	End
Preliminary Amendment	1	1
Specification	2	2
Claims	3	5
Abstract	6	6

Warnings:

Information:

4		Specification.pdf	150216 <small>bc993881c4234de5f033ba6d27998819c5ffa03d</small>	yes	18
---	--	-------------------	---	-----	----

Multipart Description/PDF files in .zip description

Document Description	Start	End
Specification	1	11
Claims	12	17
Abstract	18	18

Warnings:

Information:

5	Drawings-only black and white line drawings	Figures.pdf	45035 ecef38891beb0a061296e98498a4dcd3a4a ce3dc	no	2
Warnings:					
Information:					
6	Fee Worksheet (SB06)	fee-info.pdf	36716 e3957d1e40a59d072e736e51f2ac436d768 b6139	no	2
Warnings:					
Information:					
Total Files Size (in bytes):				2157865	
<p>This Acknowledgement Receipt evidences receipt on the noted date by the USPTO of the indicated documents, characterized by the applicant, and including page counts, where applicable. It serves as evidence of receipt similar to a Post Card, as described in MPEP 503.</p> <p><u>New Applications Under 35 U.S.C. 111</u> If a new application is being filed and the application includes the necessary components for a filing date (see 37 CFR 1.53(b)-(d) and MPEP 506), a Filing Receipt (37 CFR 1.54) will be issued in due course and the date shown on this Acknowledgement Receipt will establish the filing date of the application.</p> <p><u>National Stage of an International Application under 35 U.S.C. 371</u> If a timely submission to enter the national stage of an international application is compliant with the conditions of 35 U.S.C. 371 and other applicable requirements a Form PCT/DO/EO/903 indicating acceptance of the application as a national stage submission under 35 U.S.C. 371 will be issued in addition to the Filing Receipt, in due course.</p> <p><u>New International Application Filed with the USPTO as a Receiving Office</u> If a new international application is being filed and the international application includes the necessary components for an international filing date (see PCT Article 11 and MPEP 1810), a Notification of the International Application Number and of the International Filing Date (Form PCT/RO/105) will be issued in due course, subject to prescriptions concerning national security, and the date shown on this Acknowledgement Receipt will establish the international filing date of the application.</p>					

Electronic Acknowledgement Receipt

EFS ID:	12824173
Application Number:	13476310
International Application Number:	
Confirmation Number:	7896
Title of Invention:	MULTICARRIER MODULATION MESSAGING FOR POWER LEVEL PER SUBCHANNEL INFORMATION
First Named Inventor/Applicant Name:	David M. Krinsky
Customer Number:	62574
Filer:	Jason Vick/Joanne Vos
Filer Authorized By:	Jason Vick
Attorney Docket Number:	5550-2-CON2-1-4
Receipt Date:	21-MAY-2012
Filing Date:	
Time Stamp:	14:36:25
Application Type:	Utility under 35 USC 111(a)

Payment information:

Submitted with Payment	yes
Payment Type	Deposit Account
Payment was successfully received in RAM	\$ 1750
RAM confirmation Number	970
Deposit Account	191970
Authorized User	
<p>The Director of the USPTO is hereby authorized to charge indicated fees and credit any overpayment as follows:</p> <p style="padding-left: 40px;">Charge any Additional Fees required under 37 C.F.R. Section 1.16 (National application filing, search, and examination fees)</p> <p style="padding-left: 40px;">Charge any Additional Fees required under 37 C.F.R. Section 1.17 (Patent application and reexamination processing fees)</p>	

Charge any Additional Fees required under 37 C.F.R. Section 1.19 (Document supply fees)

Charge any Additional Fees required under 37 C.F.R. Section 1.21 (Miscellaneous fees and charges)

File Listing:

Document Number	Document Description	File Name	File Size(Bytes)/ Message Digest	Multi Part /.zip	Pages (if appl.)
1	Application Data Sheet	ADS.pdf	1425121 <small>3f25d4e09fd425ffa5140d4a43b438094c409cf</small>	no	5

Warnings:

Information:

2	Oath or Declaration filed	Parent_Declaration.pdf	71995 <small>2fc206abf5500fef7e8e8ac0bbf6e6a3a0ba1b5f</small>	no	2
---	---------------------------	------------------------	--	----	---

Warnings:

Information:

3		AMEND_PRELIM_01.pdf	428782 <small>5b5d65f7665ca398a255cd04f243e79dea3b0e8</small>	yes	6
---	--	---------------------	--	-----	---

Multipart Description/PDF files in .zip description

Document Description	Start	End
Preliminary Amendment	1	1
Specification	2	2
Claims	3	5
Abstract	6	6

Warnings:

Information:

4		Specification.pdf	150216 <small>bc993881c4234de5f033ba6d27998819c5ffa03d</small>	yes	18
---	--	-------------------	---	-----	----

Multipart Description/PDF files in .zip description

Document Description	Start	End
Specification	1	11
Claims	12	17
Abstract	18	18

Warnings:

Information:

5	Drawings-only black and white line drawings	Figures.pdf	45035 ecef38891beb0a061296e98498a4dcd3a4a ce3dc	no	2
Warnings:					
Information:					
6	Fee Worksheet (SB06)	fee-info.pdf	36716 e3957d1e40a59d072e736e51f2ac436d768 b6139	no	2
Warnings:					
Information:					
Total Files Size (in bytes):			2157865		
<p>This Acknowledgement Receipt evidences receipt on the noted date by the USPTO of the indicated documents, characterized by the applicant, and including page counts, where applicable. It serves as evidence of receipt similar to a Post Card, as described in MPEP 503.</p> <p><u>New Applications Under 35 U.S.C. 111</u> If a new application is being filed and the application includes the necessary components for a filing date (see 37 CFR 1.53(b)-(d) and MPEP 506), a Filing Receipt (37 CFR 1.54) will be issued in due course and the date shown on this Acknowledgement Receipt will establish the filing date of the application.</p> <p><u>National Stage of an International Application under 35 U.S.C. 371</u> If a timely submission to enter the national stage of an international application is compliant with the conditions of 35 U.S.C. 371 and other applicable requirements a Form PCT/DO/EO/903 indicating acceptance of the application as a national stage submission under 35 U.S.C. 371 will be issued in addition to the Filing Receipt, in due course.</p> <p><u>New International Application Filed with the USPTO as a Receiving Office</u> If a new international application is being filed and the international application includes the necessary components for an international filing date (see PCT Article 11 and MPEP 1810), a Notification of the International Application Number and of the International Filing Date (Form PCT/RO/105) will be issued in due course, subject to prescriptions concerning national security, and the date shown on this Acknowledgement Receipt will establish the international filing date of the application.</p>					

Under the Paperwork Reduction Act of 1995, no persons are required to respond to a collection of information unless it contains a valid OMB control number.

Application Data Sheet 37 CFR 1.76		Attorney Docket Number	5550-2-CON2-1-4
		Application Number	
Title of Invention	Multicarrier Modulation Messaging for Power Level Per Subchannel Information		
The application data sheet is part of the provisional or nonprovisional application for which it is being submitted. The following form contains the bibliographic data arranged in a format specified by the United States Patent and Trademark Office as outlined in 37 CFR 1.76. This document may be completed electronically and submitted to the Office in electronic format using the Electronic Filing System (EFS) or the document may be printed and included in a paper filed application.			

Secrecy Order 37 CFR 5.2

<input type="checkbox"/>	Portions or all of the application associated with this Application Data Sheet may fall under a Secrecy Order pursuant to 37 CFR 5.2 (Paper filers only. Applications that fall under Secrecy Order may not be filed electronically.)
--------------------------	---

Applicant Information:

Applicant 1					<input type="button" value="Remove"/>		
Applicant Authority		<input checked="" type="radio"/> Inventor		<input type="radio"/> Legal Representative under 35 U.S.C. 117		<input type="radio"/> Party of Interest under 35 U.S.C. 118	
Prefix	Given Name	Middle Name	Family Name	Suffix			
	David	M.	Krinsky				
Residence Information (Select One)		<input checked="" type="radio"/> US Residency		<input type="radio"/> Non US Residency		<input type="radio"/> Active US Military Service	
City	Acton	State/Province	MA	Country of Residence i	US		
Citizenship under 37 CFR 1.41(b) i		US					
Mailing Address of Applicant:							
Address 1	4 Ayre Road						
Address 2							
City	Acton	State/Province	MA				
Postal Code	01720	Country i	US				
Applicant 2					<input type="button" value="Remove"/>		
Applicant Authority		<input checked="" type="radio"/> Inventor		<input type="radio"/> Legal Representative under 35 U.S.C. 117		<input type="radio"/> Party of Interest under 35 U.S.C. 118	
Prefix	Given Name	Middle Name	Family Name	Suffix			
	Robert	Edmund	Pizzano	Jr.			
Residence Information (Select One)		<input checked="" type="radio"/> US Residency		<input type="radio"/> Non US Residency		<input type="radio"/> Active US Military Service	
City	Stoneham	State/Province	MA	Country of Residence i	US		
Citizenship under 37 CFR 1.41(b) i		US					
Mailing Address of Applicant:							
Address 1	5 Bow Street Court						
Address 2							
City	Stoneham	State/Province	MA				
Postal Code	02180	Country i	US				
All Inventors Must Be Listed - Additional Inventor Information blocks may be generated within this form by selecting the Add button.					<input type="button" value="Add"/>		

Correspondence Information:

Enter either Customer Number or complete the Correspondence Information section below. For further information see 37 CFR 1.33(a).	
<input type="checkbox"/>	An Address is being provided for the correspondence information of this application.

Under the Paperwork Reduction Act of 1995, no persons are required to respond to a collection of information unless it contains a valid OMB control number.

Application Data Sheet 37 CFR 1.76		Attorney Docket Number	5550-2-CON2-1-4
		Application Number	
Title of Invention	Multicarrier Modulation Messaging for Power Level Per Subchannel Information		
Customer Number	62574		
Email Address	jvick@sheridanross.com	<input type="button" value="Add Email"/>	<input type="button" value="Remove Email"/>

Application Information:

Title of the Invention	Multicarrier Modulation Messaging for Power Level Per Subchannel Information		
Attorney Docket Number	5550-2-CON2-1-4	Small Entity Status Claimed	<input type="checkbox"/>
Application Type	Nonprovisional		
Subject Matter	Utility		
Suggested Class (if any)		Sub Class (if any)	
Suggested Technology Center (if any)			
Total Number of Drawing Sheets (if any)	2	Suggested Figure for Publication (if any)	

Publication Information:

<input type="checkbox"/>	Request Early Publication (Fee required at time of Request 37 CFR 1.219)
<input type="checkbox"/>	Request Not to Publish. I hereby request that the attached application not be published under 35 U.S. C. 122(b) and certify that the invention disclosed in the attached application has not and will not be the subject of an application filed in another country, or under a multilateral international agreement, that requires publication at eighteen months after filing.

Representative Information:

Representative information should be provided for all practitioners having a power of attorney in the application. Providing this information in the Application Data Sheet does not constitute a power of attorney in the application (see 37 CFR 1.32). Enter either Customer Number or complete the Representative Name section below. If both sections are completed the Customer Number will be used for the Representative Information during processing.			
Please Select One:	<input checked="" type="radio"/> Customer Number	<input type="radio"/> US Patent Practitioner	<input type="radio"/> Limited Recognition (37 CFR 11.9)
Customer Number	62574		

Domestic Benefit/National Stage Information:

This section allows for the applicant to either claim benefit under 35 U.S.C. 119(e), 120, 121, or 365(c) or indicate National Stage entry from a PCT application. Providing this information in the application data sheet constitutes the specific reference required by 35 U.S.C. 119(e) or 120, and 37 CFR 1.78(a)(2) or CFR 1.78(a)(4), and need not otherwise be made part of the specification.			
Prior Application Status	Pending	<input type="button" value="Remove"/>	
Application Number	Continuity Type	Prior Application Number	Filing Date (YYYY-MM-DD)
	Continuation of	12/779660	2010-05-13
Prior Application Status	Patented	<input type="button" value="Remove"/>	

Under the Paperwork Reduction Act of 1995, no persons are required to respond to a collection of information unless it contains a valid OMB control number.

Application Data Sheet 37 CFR 1.76		Attorney Docket Number	5550-2-CON2-1-4		
		Application Number			
Title of Invention	Multicarrier Modulation Messaging for Power Level Per Subchannel Information				
Application Number	Continuity Type	Prior Application Number	Filing Date (YYYY-MM-DD)	Patent Number	Issue Date (YYYY-MM-DD)
12/779660	Continuation of	12/477742	2009-06-03	7835430	2010-11-16
Prior Application Status		Patented			<input type="button" value="Remove"/>
Application Number	Continuity Type	Prior Application Number	Filing Date (YYYY-MM-DD)	Patent Number	Issue Date (YYYY-MM-DD)
12/477742	Continuation of	10/619691	2003-07-16	7570686	2009-08-04
Prior Application Status		Patented			<input type="button" value="Remove"/>
Application Number	Continuity Type	Prior Application Number	Filing Date (YYYY-MM-DD)	Patent Number	Issue Date (YYYY-MM-DD)
10/619691	Continuation of	09/755173	2001-01-08	6658052	2003-12-02
Prior Application Status		Expired			<input type="button" value="Remove"/>
Application Number	Continuity Type	Prior Application Number	Filing Date (YYYY-MM-DD)		
09/755173	non provisional of	60/224308	2000-08-10		
Prior Application Status		Expired			<input type="button" value="Remove"/>
Application Number	Continuity Type	Prior Application Number	Filing Date (YYYY-MM-DD)		
09/755173	non provisional of	60/174865	2000-01-07		
Additional Domestic Benefit/National Stage Data may be generated within this form by selecting the Add button.					<input type="button" value="Add"/>

Foreign Priority Information:

This section allows for the applicant to claim benefit of foreign priority and to identify any prior foreign application for which priority is not claimed. Providing this information in the application data sheet constitutes the claim for priority as required by 35 U.S.C. 119(b) and 37 CFR 1.55(a).			
<input type="button" value="Remove"/>			
Application Number	Country ⁱ	Parent Filing Date (YYYY-MM-DD)	Priority Claimed
			<input type="radio"/> Yes <input checked="" type="radio"/> No
Additional Foreign Priority Data may be generated within this form by selecting the Add button.			<input type="button" value="Add"/>

Assignee Information:

Providing this information in the application data sheet does not substitute for compliance with any requirement of part 3 of Title 37 of the CFR to have an assignment recorded in the Office.	
<input type="button" value="Remove"/>	
Assignee 1	
If the Assignee is an Organization check here. <input checked="" type="checkbox"/>	
Organization Name	AWARE, INC.

Under the Paperwork Reduction Act of 1995, no persons are required to respond to a collection of information unless it contains a valid OMB control number.

Application Data Sheet 37 CFR 1.76	Attorney Docket Number	5550-2-CON2-1-4	
	Application Number		
Title of Invention	Multicarrier Modulation Messaging for Power Level Per Subchannel Information		

Mailing Address Information:			
Address 1	40 Middlesex Turnpike		
Address 2			
City	Bedford	State/Province	MA
Country	US	Postal Code	01730-1432
Phone Number		Fax Number	
Email Address			
Additional Assignee Data may be generated within this form by selecting the Add button.			
			<input type="button" value="Add"/>

Signature:

A signature of the applicant or representative is required in accordance with 37 CFR 1.33 and 10.18. Please see 37 CFR 1.4(d) for the form of the signature.					
Signature	/Jason H. Vick/			Date (YYYY-MM-DD)	2012-05-21
First Name	Jason H.	Last Name	Vick	Registration Number	45285

This collection of information is required by 37 CFR 1.76. The information is required to obtain or retain a benefit by the public which is to file (and by the USPTO to process) an application. Confidentiality is governed by 35 U.S.C. 122 and 37 CFR 1.14. This collection is estimated to take 23 minutes to complete, including gathering, preparing, and submitting the completed application data sheet form to the USPTO. Time will vary depending upon the individual case. Any comments on the amount of time you require to complete this form and/or suggestions for reducing this burden, should be sent to the Chief Information Officer, U.S. Patent and Trademark Office, U.S. Department of Commerce, P.O. Box 1450, Alexandria, VA 22313-1450. DO NOT SEND FEES OR COMPLETED FORMS TO THIS ADDRESS. **SEND TO: Commissioner for Patents, P.O. Box 1450, Alexandria, VA 22313-1450.**

Privacy Act Statement

The Privacy Act of 1974 (P.L. 93-579) requires that you be given certain information in connection with your submission of the attached form related to a patent application or patent. Accordingly, pursuant to the requirements of the Act, please be advised that: (1) the general authority for the collection of this information is 35 U.S.C. 2(b)(2); (2) furnishing of the information solicited is voluntary; and (3) the principal purpose for which the information is used by the U.S. Patent and Trademark Office is to process and/or examine your submission related to a patent application or patent. If you do not furnish the requested information, the U.S. Patent and Trademark Office may not be able to process and/or examine your submission, which may result in termination of proceedings or abandonment of the application or expiration of the patent.

The information provided by you in this form will be subject to the following routine uses:

1. The information on this form will be treated confidentially to the extent allowed under the Freedom of Information Act (5 U.S.C. 552) and the Privacy Act (5 U.S.C. 552a). Records from this system of records may be disclosed to the Department of Justice to determine whether the Freedom of Information Act requires disclosure of these records.
2. A record from this system of records may be disclosed, as a routine use, in the course of presenting evidence to a court, magistrate, or administrative tribunal, including disclosures to opposing counsel in the course of settlement negotiations.
3. A record in this system of records may be disclosed, as a routine use, to a Member of Congress submitting a request involving an individual, to whom the record pertains, when the individual has requested assistance from the Member with respect to the subject matter of the record.
4. A record in this system of records may be disclosed, as a routine use, to a contractor of the Agency having need for the information in order to perform a contract. Recipients of information shall be required to comply with the requirements of the Privacy Act of 1974, as amended, pursuant to 5 U.S.C. 552a(m).
5. A record related to an International Application filed under the Patent Cooperation Treaty in this system of records may be disclosed, as a routine use, to the International Bureau of the World Intellectual Property Organization, pursuant to the Patent Cooperation Treaty.
6. A record in this system of records may be disclosed, as a routine use, to another federal agency for purposes of National Security review (35 U.S.C. 181) and for review pursuant to the Atomic Energy Act (42 U.S.C. 218(c)).
7. A record from this system of records may be disclosed, as a routine use, to the Administrator, General Services, or his/her designee, during an inspection of records conducted by GSA as part of that agency's responsibility to recommend improvements in records management practices and programs, under authority of 44 U.S.C. 2904 and 2906. Such disclosure shall be made in accordance with the GSA regulations governing inspection of records for this purpose, and any other relevant (i.e., GSA or Commerce) directive. Such disclosure shall not be used to make determinations about individuals.
8. A record from this system of records may be disclosed, as a routine use, to the public after either publication of the application pursuant to 35 U.S.C. 122(b) or issuance of a patent pursuant to 35 U.S.C. 151. Further, a record may be disclosed, subject to the limitations of 37 CFR 1.14, as a routine use, to the public if the record was filed in an application which became abandoned or in which the proceedings were terminated and which application is referenced by either a published application, an application open to public inspections or an issued patent.
9. A record from this system of records may be disclosed, as a routine use, to a Federal, State, or local law enforcement agency, if the USPTO becomes aware of a violation or potential violation of law or regulation.

PATENT APPLICATION
Attorney Docket No. 081513.00004

DECLARATION AND POWER OF ATTORNEY FOR PATENT APPLICATION

As a below named inventor, I hereby declare that:

My residence, post office address and citizenship are as stated below next to my name,

I believe I am the original, first and sole inventor (if only one name is listed below) or an original, first and joint inventor (if plural names are listed below) of the subject matter which is claimed and for which a patent is sought on the invention entitled: **SYSTEMS AND METHODS FOR ESTABLISHING A DIAGNOSTIC TRANSMISSION MODE AND COMMUNICATING OVER THE SAME**

the specification and claims of which are attached hereto OR was filed on _____ as U.S. Application No. _____

I hereby state that I have reviewed and understand the contents of the above-identified specification, including the claims.

I acknowledge the duty to disclose information which is material to the patentability as defined in Title 37, Code of Federal Regulations, §1.56.

I hereby claim priority benefits under Title 35, United States Code, §119 of any foreign or U.S. Provisional application(s) for patent listed below, and have also identified below any foreign application(s) or Provisional application(s) for patent having a filing date before that of the application on which priority is claimed:

Prior Foreign or U.S. Provisional Application(s)

<u>60/224,308</u> (Number)	<u>U.S.A.</u> (Country)	<u>August 10, 2000</u> (Day/Month/Year Filed)
<u>60/174,865</u> (Number)	<u>U.S.A.</u> (Country)	<u>January 7, 2000</u> (Day/Month/Year Filed)

POWER OF ATTORNEY: As a named inventor, I hereby appoint the following registered practitioners to prosecute this application and transact all business in the Patent and Trademark Office connected therewith.

Daniel W. Sixbey	20,932	Daniel S. Song	43,143
Stuart J. Friedman	24,312	Marc S. Kaufman	35,212
Charles M. Leedom, Jr.	26,477	James E. Howard	39,175
David S. Safran	27,997	Corinne R. Gorski	34,339
Thomas W. Cole	28,290	Kenneth H. Salen	43,077
Donald R. Studebaker	32,815	Jason H. Vick	45,285
Jeffrey L. Costellia	35,483	Carolyn Baumgardner	41,345
Tim L. Brackett, Jr.	36,092	Luan C. Do	38,434
Eric J. Robinson	38,285		

Direct all correspondence to: Customer Number 22204

ADDRESS ALL CORRESPONDENCE TO:	DIRECT TELEPHONE CALLS TO: (name and telephone number)
Eric J. Robinson, Esq. NIXON PEABODY LLP 8180 Greensboro Drive Suite 800 McLean, Virginia 22102	Eric J. Robinson (703) 790-9110

I hereby declare that all statements made herein of my own knowledge are true and that all statements made on information and belief are believed to be true; and further that these statements were made with the knowledge that willful false statements and the like so made are punishable by fine or imprisonment, or both, under §1001 of Title 18 of the United States Code and that such willful false statements may jeopardize the validity of the application or any patent issuing thereon.

DECLARATION AND POWER OF ATTORNEY, continued

Name of sole or first inventor: David M. KRINSKY

Inventor's Signature: *David M. Krinsky*
Residence: 4 Ayer Road
Acton, MA 01720

Date: 1/8/01

Citizenship: U.S.

Post Office Address:
(Same as above)

Name of second inventor: Robert Edmund PIZZANO, Jr.

Inventor's Signature: *Robert Edmund Pizzano Jr.*
Residence: 5 Bow Street Court
Stoneham, MA 02180

Date: 1/8/01

Citizenship: U.S.

Post Office Address:
(Same as above)

NVA166186.1

Substitute for form 1449A/PTO				Complete if Known	
INFORMATION DISCLOSURE STATEMENT BY APPLICANT				Application Number	13/476310
				Filing Date	May 21, 2012
				First Named Inventor	David M. Krinsky et al.
				Art Unit	
				Examiner Name	
Sheet	1	of	6	Attorney Docket Number	5550-2-CON2-1-4

U.S. PATENT DOCUMENTS					
Examiner Initials*	Cite No. ¹	Document Number Number-kind Code ^{2 (if known)}	Publication Date MM-DD-YYYY	Name of Patentee of Applicant of Cited Document	Pages, Columns, Lines, Where Relevant Passages or Relevant Figures Appear
	1	4385384	05-24-1983	Rosbury et al.	
	2	4566100	01-21-1986	Mizuno et al.	
	3	5128619	07-07-1992	Bjork et al.	
	4	5361293	11-01-1994	Czerwiec	
	5	5608643	03-04-1997	Wichter et al.	
	6	5612960	03-18-1197	Stevens et al.	
	7	5864602	01-26-1999	Needle	
	8	5964891	10-12-1999	Caswell et al.	
	9	6073179	06-06-2000	Liu et al.	
	10	6075821	06-13-2000	Kao et al.	
	11	6175934	01-16-2001	Hershey et al.	
	12	6188717	02-13-2001	Kaiser et al.	
	13	6219378	04-17-2001	Wu	
	14	6249543	06-19-2001	Chow	
	15	6404774	06-11-2002	Jenness	
	16	6411678	06-25-2002	Tomlinson, Jr. et al.	
	17	6445773	09-03-2002	Liang et al.	
	18	6449307	09-10-2002	Ishikawa et al.	
	19	6512789	01-28-2003	Mirfakhraei	
	20	6631120	10-07-2003	Milbrandt	
	21	6633545	10-14-2003	Milbrandt	
	22	6636603	10-21-2003	Milbrandt	
	23	6658052	12-02-2003	Krinsky et al.	
	24	6725176	01-20-2004	Long et al.	
	25	6781513	08-24-2004	Korkosz et al.	
	26	7570686	08-04-2009	Krinsky et al.	
	27	7835430	11-16-2010	Krinsky et al.	
	28	7889784	02-15-2011	Krinsky et al.	
	29	2010/0226418	09-09-2010	Krinsky et al.	
	30	2011/0103443	05-05-2011	Krinsky et al.	

Examiner Signature		Date Considered	
--------------------	--	-----------------	--

*EXAMINER: Initial if reference is considered, whether or not citation is in conformance and not considered. Include copy of this form with next communication to applicant.

Substitute for form 1449A/PTO				Complete if Known	
INFORMATION DISCLOSURE STATEMENT BY APPLICANT				Application Number	13/476310
				Filing Date	May 21, 2012
				First Named Inventor	David M. Krinsky et al.
				Art Unit	
				Examiner Name	
Sheet	2	of	6	Attorney Docket Number	5550-2-CON2-1-4

FOREIGN PATENT DOCUMENTS						
Examiner Initials*	Cite No. ¹	Foreign Patent Document Country Code ³ ; Number ⁴ ; Kind Code ⁵ (if known)	Publication Date MM-DD-YYYY	Name of Patentee or Applicant of Cited Document	Pages, Columns, Lines, Where Relevant Passages or Relevant Figures Appear	T ⁶
	31	EP 0889615	01-07-2009	INTEGRATED TELECOM EXPRESS		
	32	GB 2303032	02-05-1997	SAMSUNG ELECTRONICS CO LTD		
	33	JP Hei6(1994)-003956	01-12-1994	TELEBIT CORPORATION		(believed to correspond to WO 86/07223 disclosed herein)
	34	JP-A-Hei10(1998)-513622	12-22-1998	ADC TELECOMMUNICATIONS INC		(believed to correspond to WO96/24995 cited herein)
	35	JP-A-Hei11(1999)-261665	09-24-1999	MATSUSHITA GRAPHIC COMMUNICATION SYSTEM INC.		(includes abstract)
	36	JP-A-Hei11(1999)-317723	11-16-1999	MOTOROLA INC		(includes abstract)
	37	JP-A-Hei11(1999)-508417	07-21-1999	ERICSSON TELEFON AB L M		(believed to correspond to WO97/01256 cited herein)
	38	WO 00/64130	10-26-2000	TERADYNE INC		
	39	WO 86/07223	12-04-1986	TELEBIT CORPORATION		(believed to correspond to JP Hei6(1994)-003956 disclosed herein)
	40	WO 96/24995	08-15-1996	ADC TELECOMMUNICATIONS INC		

Examiner Signature		Date Considered	
--------------------	--	-----------------	--

*EXAMINER: Initial if reference is considered, whether or not citation is in conformance and not considered. Include copy of this form with next communication to applicant.

Substitute for form 1449A/PTO				Complete if Known	
INFORMATION DISCLOSURE STATEMENT BY APPLICANT				Application Number	13/476310
				Filing Date	May 21, 2012
				First Named Inventor	David M. Krinsky et al.
				Art Unit	
				Examiner Name	
Sheet	3	of	6	Attorney Docket Number	5550-2-CON2-1-4

	41	WO 97/01256	01-09-1997	ERICSSON TELEFON AB L M		
	42	WO 97/01900	01-16-1997	ERICSSON AUSTRIA AG		
	43	WO 99/020027	04-22-1999	Aware, Inc.		
	44	WO 99/26375	05-27-1999	TEKTRONIX INC		
	45	WO 99/63427	12-09-1999	GTE LABORATORIES INC		
	46	WO 99/67890	12-29-1999	PC TEL INC		

OTHER ART (Including Author, Title, Date, Pertinent Pages, etc.)		
Examiner Initials*	Cite No. ¹	
	47	BOETS et al., "Modeling Aspect of Transmission Line Networks," Proceedings Of The Instrumentation And Measurement Technology Conference, US, New York, IEEE, May 12, 1992, pp. 137-141, XP000343913 ISBN: 0-7803-0640-6
	48	CIOFFI, John M., ADSL Maintenance with DMT, T1E1.4 ADSL Project, Amati Communications Corporation, Dec. 1, 1992, pages 1-14
	49	LEWIS et al., "Extending Trouble Ticket System to Fault Diagnostics," IEEE Network, IEEE Inc. New York, US, Nov. 1, 1993, pp. 44-51, XP 000575228
	50	"Asymmetric Digital Subscriber Line (ADSL) Transceivers," ITU-T G.992.1, Jun. 1999, pp. 91-117, 125, 126, 131, 132
	51	ITU-T Recommendation G.992.2, "Splitterless asymmetric digital subscriber line (ADSL) transceivers," International Telecommunication Union, Jun. 1999, 179 pages
	52	ITU-T Recommendation G.994.1, "Handshake procedures for digital subscriber line (DSL) transceivers," International Telecommunication Union, Jun. 1999, 56 pages
	53	International Search Report for PCT/US01/00418 dated Jul. 16, 2001 (Attorney Ref. No. 5550-2-PCT), 4 pages

Examiner Signature	Date Considered
--------------------	-----------------

*EXAMINER: Initial if reference is considered, whether or not citation is in conformance and not considered. Include copy of this form with next communication to applicant.

Substitute for form 1449A/PTO				Complete if Known	
INFORMATION DISCLOSURE STATEMENT BY APPLICANT				Application Number	13/476310
				Filing Date	May 21, 2012
				First Named Inventor	David M. Krinsky et al.
				Art Unit	
				Examiner Name	
Sheet	4	of	6	Attorney Docket Number	5550-2-CON2-1-4

54	Written Opinion for International (PCT) Patent Application No. PCT/US01/00418, mailed Jan. 18, 2002 (Attorney Ref. No. 5550-2-PCT), 2 pages
55	International Preliminary Examination Report for International (PCT) Patent Application No. PCT/US01/00418, completed Mar. 9, 2002 (Attorney Ref. No. 5550-2-PCT), 2 pages
56	PCT International Search Report dated Oct. 9, 2002 for PCT/US01/41653 (Attorney Ref. No. 5550-2-PCT-3)
57	Examiner's First Report for Australian Patent Application No. 27669/01, dated Apr. 2, 2004 (Attorney Ref. No. 5550-2-PAU)
58	Notice of Acceptance for Australian Patent Application No. 27669/01, dated Aug. 6, 2004 (Attorney Ref. No. 5550-2-PAU)
59	Examiner's First Report for Australian Patent Application No. 2004203321, dated Nov. 16, 2006 (Attorney Ref. No. 5550-2-PAU-4)
60	Notice of Acceptance for Australian Patent Application No. 2004203321, dated Aug. 7, 2008 (Attorney Ref. No. 5550-2-PAU-4)
61	Examiner's First Report for Australian Patent Application No. 2008203520, mailed Mar. 9, 2009 (Attorney Ref. No. 5550-2-PAU-4-DIV)
62	Notice of Acceptance for Australian Patent Application No. 2008203520, mailed Jul. 9, 2009 (Attorney Ref. No. 5550-2-PAU-4-DIV)
63	Examination Report for Australian Patent Application No. 2009222537, dated Mar. 21, 2011 (Attorney Ref. No. 5550-2-PAU-4-DIV-2)
64	Examination Report for Australian Patent Application No. 2009222537, dated May 27, 2011 (Attorney Ref. No. 5550-2-PAU-4-DIV-2)
65	Notice of Acceptance for Australian Patent Application No. 2009222537, dated Aug. 25, 2011 (Attorney Ref. No. 5550-2-PAU-4-DIV-2)
66	Official Action for Canadian Patent Application No. 2,394,491, mailed Nov. 24, 2009 (Attorney Ref. No. 5550-2-PCA)
67	Notice of Allowance for Canadian Patent Application No. 2,394,491, dated Jul. 16, 2010 (Attorney Ref. No. 5550-2-PCA)
68	Official Action for Canadian Patent Application No. 2,726,826, dated Jun. 30, 2011 (Attorney Ref. No. 5550-2-PCA-DIV)
69	Notice of Allowance for Canadian Patent Application No. 2,726,826, dated March 1, 2012 (Attorney Ref. No.: 5550-2-PCA-DIV)

Examiner Signature		Date Considered	
--------------------	--	-----------------	--

*EXAMINER: Initial if reference is considered, whether or not citation is in conformance and not considered. Include copy of this form with next communication to applicant.

Substitute for form 1449A/PTO				Complete if Known	
INFORMATION DISCLOSURE STATEMENT BY APPLICANT				Application Number	13/476310
				Filing Date	May 21, 2012
				First Named Inventor	David M. Krinsky et al.
				Art Unit	
				Examiner Name	
Sheet	5	of	6	Attorney Docket Number	5550-2-CON2-1-4

	70	Official Action for European Patent Application No. 01901808.4, mailed Dec. 1, 2004 (Attorney Ref. No. 5550-2-PEP)
	71	Official Action for European Patent Application No. 01901808.4, mailed Sep. 14, 2005 (Attorney Ref. No. 5550-2-PEP)
	72	Communication about intention to grant a European patent for European Patent Application No. 01901808.4, mailed May 15, 2006 (Attorney Ref. No. 5550-2-PEP)
	73	European Search Report for European Patent Application No. EP 06022008 completed Jan. 8, 2007 (Attorney Ref. No. 5550-2-PEP-5)
	74	Official Action for European Patent Application No. EP 06022008.4, mailed Sept. 20, 2007 (Attorney Ref. No. 5550-2-PEP-5)
	75	Official Action for European Patent Application No. EP 06022008, dated Apr. 23, 2010 (Attorney Ref. No. 5550-2-PEP-5)
	76	Official Action for European Patent Application No. EP 06022008, mailed Jul. 7, 2010 (Attorney Ref. No. 5550-2-PEP-5)
	77	Communication Under Rule 71(3) EPC for European Patent Application No. EP 06022008, dated Apr. 4, 2011 (Attorney Ref. No. 5550-2-PEP-5)
	78	Notification of Reasons (including translation) for Refusal for Japanese Patent Application No. 2001-552611, Dispatched Date: December 7, 2009 (Attorney Ref. No. 5550-2-PJP)
	79	Official Action (including translation) for Japanese Patent Application No. 2001-552611, mailed Aug. 2, 2010 (Attorney Ref. No. 5550-2-PJP)
	80	Official Action (including translation) for Japanese Patent Application No. 2001-552611, mailed Mar. 28, 2011 (Attorney Ref. No. 5550-2-PJP)
	81	Official Action (including translation) for Japanese Patent Application No. 2008-191051, mailed Jul. 26, 2010 (Attorney Ref. No. 5550-2-PJP-DIV)
	82	Notice of Allowance for Japanese Patent Application No. 2008-190051, mailed Mar. 14, 2011 (Attorney Ref. No. 5550-2-PJP-DIV)
	83	Decision to Grant Patent (including translation) For Korean Patent Application No. 10-2002-7008794, dated Dec. 1, 2006 (Attorney Ref. No. 5550-2-PKR)
	84	Official Action for U.S. Patent Application No. 09/755,173, mailed Jun. 20, 2002 (Attorney Ref. No. 5550-2)
	85	Official Action for U.S. Patent Application No. 09/755,173, mailed Sep. 24, 2002 (Attorney Ref. No. 5550-2)

Examiner Signature		Date Considered	
--------------------	--	-----------------	--

*EXAMINER: Initial if reference is considered, whether or not citation is in conformance and not considered. Include copy of this form with next communication to applicant.

Substitute for form 1449A/PTO				Complete if Known	
INFORMATION DISCLOSURE STATEMENT BY APPLICANT				Application Number	13/476310
				Filing Date	May 21, 2012
				First Named Inventor	David M. Krinsky et al.
				Art Unit	
				Examiner Name	
Sheet	6	of	6	Attorney Docket Number	5550-2-CON2-1-4

	86	Official Action for U.S. Patent Application No. 09/755,173, mailed Mar. 14, 2003 (Attorney Ref. No. 5550-2)
	87	Notice of Allowance for U.S. Patent Application No. 09/755,173, mailed Jul. 1, 2003 (Attorney Ref. No. 5550-2)
	88	Official Action for U.S. Patent Application No. 10/619,691, mailed Oct. 31, 2006, 14 pages (Attorney Ref. No. 5550-2-CON-2)
	89	Official Action for U.S. Patent Application No. 10/619,691, mailed Mar. 30, 2007, 11 pages (Attorney Ref. No. 5550-2-CON-2)
	90	Official Action for U.S. Patent Application No. 10/619,691, mailed Jun. 13, 2008, 7 pages (Attorney Ref. No. 5550-2-CON-2)
	91	Official Action for U.S. Patent Application No. 10/619,691, mailed Oct. 20, 2008, 11 pages (Attorney Ref. No. 5550-2-CON-2)
	92	Notice of Allowance for U.S. Patent Application No. 10/619,691, mailed May 15, 2009, 9 pages (Attorney Ref. No. 5550-2-CON-2)
	93	Supplemental Notice of Allowability for U.S. Patent Application No. 10/619,691, mailed July 6, 2009, 5 pages (Attorney Ref. No. 5550-2-CON-2)
	94	Official Action for U.S. Patent Application No. 12/477,742, mailed Jun. 8, 2010 (Attorney's Ref. No. 5550-2-CON-2-1), 10 pages
	95	Official Action for U.S. Patent Application No. 12/477,742, mailed Aug. 16, 2010 (Attorney Ref. No. 5550-2-CON-2-1), 9 pages
	96	Notice of Allowance for U.S. Patent Application No. 12/477,742, mailed Sep. 7, 2010 (Attorney Ref. No. 5550-2-CON-2-1), 6 pages
	97	Office Action for U.S. Patent Application No. 12/779,660, mailed March 19, 2012 (Attorney Ref. No.: 5550-2-CON-2-1-1)
	98	Notice of Allowance for U.S. Patent Application No. 12/779,660, mailed April 26, 2012 (Attorney Ref. No.: 5550-2-CON-2-1-1)
	99	Official Action for U.S. Patent Application No. 12/779,708, mailed Sep. 29, 2010 (Attorney Ref. No. 5550-2-CON-2-1-2), 6 pages
	100	Official Action for U.S. Patent Application No. 12/779,708, mailed Dec. 15, 2010 (Attorney Ref. No. 5550-2-CON-2-1-2), 6 pages
	101	Notice of Allowance for U.S. Patent Application No. 12/779,708, mailed Jan. 3, 2011 (Attorney Ref. No. 5550-2-CON-2-1-2), 6 pages

Examiner Signature		Date Considered	
--------------------	--	-----------------	--

*EXAMINER: Initial if reference is considered, whether or not citation is in conformance and not considered. Include copy of this form with next communication to applicant.



(12) **EUROPEAN PATENT APPLICATION**

(43) Date of publication:
07.01.1999 Bulletin 1999/01

(51) Int. Cl.⁶: **H04L 5/14, H04L 27/26**

(21) Application number: **98112040.5**

(22) Date of filing: **30.06.1998**

(84) Designated Contracting States:
AT BE CH CY DE DK ES FI FR GB GR IE IT LI LU
MC NL PT SE
 Designated Extension States:
AL LT LV MK RO SI

(72) Inventors:
 • **Liu, Young Way**
La Mirada, California 90638 (US)
 • **Liu, Ming-Kang**
Cupertino, California 95014 (US)
 • **Chen, Steve**
San Jose, California 95132 (US)

(30) Priority: **30.06.1997 US 884895**

(71) Applicant:
Integrated Telecom Express
Santa Clara, California 95051 (US)

(74) Representative:
Lins, Edgar, Dipl.-Phys. Dr.jur.
Gramm, Lins & Partner GbR,
Theodor-Heuss-Strasse 1
38122 Braunschweig (DE)

(54) **Multicarrier transmission with variable data rate**

(57) A high speed communications system is provided which uses a selectable, desirable portion of the total available bandwidth of a transmission channel. In a preferred embodiment, the invention is an ADSL compatible modem which selects a sub-set of the available downstream DMT sub-channels based on an evaluation of such sub-channels by appropriate signal processing circuitry. An analog front end (AFE) contains sub-band filtering causes an upstream transceiver to use only this selected number of available sub-channels for down-

stream data transmission. This reduces hardware costs and complexity while still preserving compatibility with applicable ADSL standards and providing a high speed data link. The target data rate of the modem can be further enhanced to the point of achieving full protocol capability by increasing or upgrading the AFEs, and/or the signal processing circuitry in order to increase the number of processable transmitted downstream sub-channels.

FIGURE 6

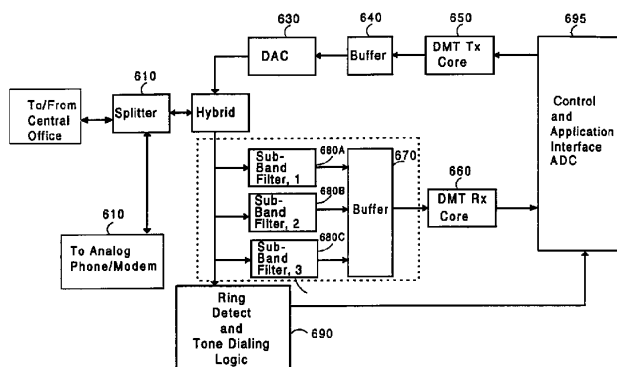

DescriptionFIELD OF THE INVENTION

5 The invention relates generally to an improved high-speed communications system which establishes a data link using only a selectable portion of the total available bandwidth of a channel. The present invention has particular applicability to systems which use rate adaptable techniques such as the discrete multi-tone modulation (DMT) technique and CAP for transmitting data in Digital Subscriber Lines and similar environments. By limiting the data throughput of the link to some adjustable fraction of the total available data rate, the present invention significantly reduces hardware costs and allows a downstream user to configure a data link whose performance is directly controllable by the processing power available to such user. In this manner, the system is completely forward compatible and expandable in functionality, and permits a user to increase throughput to the point of achieving full potential of the available channel bandwidth .

15 BACKGROUND OF THE INVENTION

Remote access and retrieval of data and information are becoming more desirable and common in both consumer and business environments. As data and information transfer is becoming more and more voluminous and complex, using traditional data links such as voice-band modems is too slow in speed. For example, the use of the Internet to locate and access information is increasing daily, but the retrieval of typical graphics, video, audio, and other complex data forms is generally unsatisfyingly slow using conventional voice-band modems. In fact, the slow rate of existing dial-up analog modems frustrates users, and commerce and interaction using the Internet would have been even higher were it not for the unacceptable delays associated with present day access technology. The ability to provide such desired services as video on demand, television (including HDTV, video catalogs, remote CD-ROMs, high-speed LAN access, electronic library viewing, etc., are similarly impeded by the lack of high speed connections.

Since the alternatives to copper line technology have proven unsatisfactory, solutions to the high speed access problem have been focused on improving the performance of voice band modems. Voice band modems operate at the subscriber premises end over a 3 kHz voice band lines and transmit signals through the core switching network, the phone company network treats them exactly like voice signals. These modems presently transmit up to 33.6 kbps over a 2-wire telephone line, even though the practical speed only twenty years ago was 1.2 kbps. The improvement in voice band modems over the past 20 years has resulted from significant advances in algorithms, digital signal processing, and semiconductor technology. Because such modems are limited to voice bandwidth (3.0 kHz), the rate is bound by the Shannon limit, around 30 kbps. A V.34 modem, for example, achieves 10 bits per Hertz of bandwidth, a figure that approaches the theoretical Shannon limits.

35 There is a considerable amount of bandwidth available in copper lines, however, that has gone unused by voice band modems, and this is why a proposal known as Asymmetric Digital Subscriber Line (ADSL) was suggested in the industry as a high-speed protocol/connection alternative. The practical limits on data rate in conventional telephone line lengths (of 24 gauge twisted pair) vary from 1.544 Mbps for an 18,000 foot connection, to 51.840 Mbps for a 1,000 foot connection. Since a large proportion of current telephone subscribers fall within the 18,000 foot coverage range, ADSL can make the current copper wire act like a much "bigger pipe" for sending computer bits and digital information (like movies and TV channels), while still carrying the voice traffic. For example, an ADSL modem can carry information 200 times faster than the typical voice band modem used today.

45 ADSL is "asymmetric" in that more data goes downstream (to the subscriber) than upstream (back from the subscriber). The reason for this is a combination of cost, demand, and performance. For example, twisted pair wiring coupling increases with the frequency of the signal. If symmetric signals in many pairs are used within a cable, the data rate and line length become significantly limited by the coupling noise. Since the preponderance of target applications for digital subscriber services is asymmetric, asymmetric bit rate is not perceived to be a serious limitation at this time. Therefore, the ADSL standard proposes up to 6 Mbps for downstream, and up to 640 kbps for upstream. For example, video on demand, home shopping, Internet access, remote LAN access, multimedia access, and specialized PC services all feature high data rate demands downstream, to the subscriber, but relatively low data rates demands upstream. The principal advantage is that all of the high speed data operations take place in a frequency band above the voice band, leaving Plain Old Telephone Service (POTS) service independent and undisturbed, even if an ADSL modem fails. ADSL further provides an economical solution for transmission of high bandwidth information over existing copper line infrastructures.

55 Specifically, the proposed standard for ADSL divides the available transmission bandwidth into two parts. At the lower 4 kHz band, ordinary (POTS) is provided. The bulk of the rest bandwidth in the range from 4 kHz to about 1 MHz is for data transmission in the downstream direction, which is defined to be from the exchange to the subscriber. The upstream control channel uses a 160 kHz band in between. The signals in each channel can be extracted with an

appropriate band -pass filter.

A DMT implementation of ADSL uses the entire available 1 MHz range of a copper phone line. It merely splits the signal into 255 separate channels, and each 4 kHz channel can be made to provide a bit rate up to the best present day voice band (33.6 kbs) modems. This results essentially in overall performance which is equivalent to around two hundred V.34 modems used in parallel on the same line. Because each channel can be configured to a different bit rate according to the channel characteristics, it can be seen that DMT is inherently "rate-adaptive" and extremely flexible for interfacing with different subscriber equipment and line conditions.

A number of problems arise, however, in attempting to implement a full scale ADSL transceiver cost-effectively.

First, to achieve this high bit rate transmission over existing telephone subscriber loops, advanced analog front end (AFE) devices, complicated digital signal processing techniques, and high speed complex digital designs are required. As a result, this pushes current technology limits and imposes both high cost and power consumption. For example, AFE devices in modem applications provide the interface between analog wave forms and digital samples for digital hardware/software processing. In high speed modern technologies such as ADSL, AFE devices need to operate at a very high sampling rate and high accuracy. For example, the DMT technology has a spectrum of 1 MHz and requires sampling above 50 MHz if a sigma-delta analog-to-digital (ADC) method is used. This thus requires the state-of-art ADC technology and imposes a high cost for end users.

Second, the time domain signal in ADSL/DMT transmissions is a summation of a large number of carriers modulated by quadrature amplitude modulation (QAM). This typically results in a large peak-to-peak deviation. As a result, even though a high speed AFE is made possible, a large dynamic range and high resolution AFE is required at the same time to minimize quantization errors.

Third, in addition to the high sampling rate and resolution requirement for ADSL AFEs, the other hardware and software in ADSL environment also needs to operate at a much higher speed than current conventional modem counterparts. For example, to implement the DMT technology in software, a custom and dedicated digital signal process (DSP) of a power of several hundred MIPS (millions instructions per second) is required to process many components such as error encoding and decoding, spectrum transforms, timing synchronization, etc. As with the AFE part of the system, this high speed requirement for the signal processing portion of ADSL also results in less flexible, high component costs.

Fourth, requiring a communications device (such as a modem) to fully support the total throughput of a standard such as ADSL may be inefficient in some cases, since many prospective users of high-speed data links may not need to use all the available bandwidth provided by such standards. It is generally more preferable therefore to permit users to throttle or scale the data throughput in a manner they can control, based on their particular application needs, hardware cost budget, etc. For example, a full-scale ADSL system may have the performance level of 200 times conventional V.34 modems, but it is apparent that even a performance improvement of 10 - 20 times than present day available analog modems would be sufficient for many consumer applications, such as Internet access and similar uses. Thus, unlike conventional analog modems, which are available in various speeds varying generally from 14.4 to 56 Kbps, there are no known ADSL modems which offer scalable performance levels to users.

Fifth, in addition to the implementation challenge, the T1E1.4 ADSL standard does not specify the system interface and user model. Although various high level interface to support T1/E1, ATM, etc. have been described, system integration with high level protocols such as TCP/IP and interface with computer operating systems have not yet been defined. As a result, there is uncertainty how existing and future modem-based applications can work with the ADSL technology. For example, when users run an Internet application which sends and receives data to and from an Internet service provider (ISP), a mutually agreed protocol is required to set up a call and transfer data. Possible protocols available at various levels include ATM (asynchronous transfer mode), TCP/IP, ISDN, and current modem AT commands. Either one of these or a possibly new protocol needs to be defined to facilitate the adoption of ADSL technology.

SUMMARY OF THE INVENTION

An object of the present invention therefore is to provide a communications system which is fully compatible with high speed, rate adaptable protocols such as are used with ADSL, but which system is nevertheless implementable with simpler analog front end receiving/transmitting circuitry and is thus reduced in cost and complexity;

A further object of the present invention is to provide a communications system which is fully compatible with high speed, rate adaptable modulation protocols such as used with ADSL, but which system is nevertheless implementable with simpler digital signal processing circuitry and is thus reduced in cost and complexity;

Another objective of the present invention is to provide a method for transmitting data within a fractional, desirable portion of available bandwidth in a channel by modulating only a limited number of desirable sub-channel data carriers, so that a high speed data link can be achieved that is faster, and has reduced computation and hardware demands;

Yet a further objective of the present invention is to provide a communications system with smaller peak-to-peak deviation in the sub-channels signals, so as to reduce the dynamic range required for the front end ADC, and to mini-

mize quantization errors.

Another objective of the present invention is to provide a high speed communications system having a data throughput that is easily controllable and expandable, so that the performance range of such system can be configured to any fractional percentage of total bandwidth available in a transmission channel, up to and including full bandwidth use of the channel;

A related objective of the present invention is to provide a high speed communications system that is modular so that forward compatible and expandable functionality can be incorporated flexibly and with a minimum of effort on the part of a user of such system;

Yet a further objective is to provide a system that is compatible with high speed protocols used in ADSL, but which is also easily adaptable to support preexisting high level data protocols, including those presently used for controlling high speed voice band modems;

A further object of the present invention is to provide a high speed communications system that self-calibrates its own performance level, based on the processing power available to such system;

Another objective of the present invention is to provide a high speed communications system that permits a user to configure the performance parameters of such system using conventional personal computer hardware, software and operating systems;

A further object of the present invention is to provide an interface between a host operating system and a high speed communications system that provide forward compatible and expandable functionality;

An additional aim of the present invention is to provide an improved system for concurrent control of conventional voice data traffic on a POTS channel, and upstream/downstream communications on separate sub-channels;

These objects and others are accomplished by providing a communications system that permits a host processing device to receive selected data within a narrow bandwidth from an upstream transceiver which can and normally transmits a large bandwidth analog data transmission signal through a connected channel. A channel interface circuit AFE samples the received analog signal to generate a digital signal. Only a limited portion of the bandwidth may be sampled, thus reducing front end complexity. A digital signal processing circuit then extracts the selected data from this limited digital signal, which is significantly easier to process than a full bandwidth digital signal. Feedback information is provided back to the upstream transmitter which causes the upstream transmitter to transmit downstream data thereafter only using the limited bandwidth of the front end, and not the full bandwidth. This feedback information contains information about the channel that suggests to the upstream transmitter that the other bandwidth in the channel is unusable. In this manner, the upstream transceiver is trained to accommodate the lower rate downstream transceiver in a manner that nevertheless preserves protocol integrity.

In a preferred embodiment, the large bandwidth analog data transmission signal is comprised of a number of DMT modulated sub-channels, and an anti-aliasing filter on the front end of the the downstream transceiver ensures that only a limited number of such sub-channels are processed by a DMT signal processing core. The feedback information consists of non-zero SNR information for the selected sub-channels, and a sub-channel blackout "mask" to eliminate the potential use of other sub-channels. The feedback information is sent by way of a front end transmitting circuit which transmits an upstream data transmission using a second frequency range different from the downstream transmission.

One implementation of the aforementioned high speed system is in a personal computer, so that the signal processing can be accomplished using a processor within such computer, which in a preferred embodiment is an X86 compatible processor. Another implementation of the aforementioned high speed system uses a dedicated signal processor for demodulating the selected sub-channels. This cuts down on processing overhead requirements for a host processing system incorporating the system. In such implementations the portion of the downstream data transmission to be processed for data extraction can be configured by a user of such systems, or alternatively, it can be dynamically determined based on an evaluation by the digital signal processing circuit of performance characteristics of different portions of the frequency spectrum within the bandwidth potential of the upstream transceiver.

In another variation, the data rate of a system such as described above can be increased by processing data from an additional second limited frequency bandwidth portion of the total available downstream bandwidth. In a preferred embodiment, this can be done by including a number of anti-aliasing filters in a modular bank as part of the analog front end section, each of which passes a different frequency bandwidth portion. By making the analog front end modular, the data rate of the overall system can be scaled in a controllable and cost-effective fashion. At the same time, each analog front end portion can be operated at a slower sampling clock and smaller dynamic range. This results in a more relaxed speed requirement and smaller quantization noise at a given number of bits per sample.

The present disclosure also includes an interface to an operating system, to facilitate controlling the high speed communications system when it is incorporated in a personal computer system. This interface ensures that the operating system treats such communications system essentially the same as other prior art voice band modems, and in a preferred embodiment, is a device driver for the Windows NT operating shell. Finally, the present disclosure also describes an applications program which permits a user of a personal computer to control the performance characteristics of the high speed communications system by setting certain system parameters when such system is incorpo-

rated in a personal computer system. This program includes an auto calibration routine for setting such system parameters, or alternatively a user of such program can tailor the settings subject to confirmation of the efficacy of such settings based on an evaluation of the processing power available to such user.

5 Although the inventions are described below in a preferred embodiment implementing the ADSL standard, it will be apparent to those skilled in the art the present invention would be beneficially used in any high speed rate-adaptable applications.

10 It should be noted that while some prior art devices also have limited mechanisms for achieving a reduction of nominal or peak transmission speed in a channel, they only activate or implement such mechanisms as a fallback response to a failure in the channel, or because of a transmission rate reduction in the upstream transceiver. Unlike the present invention, such prior art modems, during an initialization process, attempt to establish the highest possible transmission rate achievable by the channel and the upstream transceiver. In other words, any rate reduction imposed by the downstream modem is typically considered an unintended and undesirable side effect of bad channel characteristics, and not a desirable and intentional design target as set forth in the present invention. In addition, the data rate reduction in such modems is accomplished primarily by varying the number of bits per baud (hertz) at a fixed frequency, and nor by 15 controlling the overall frequency spectrum of the downstream data transmission. Moreover, in such prior art systems, no effort is made to measure, identify or use an optimal portion of the usable bandwidth or set of transmission sub-channels. Instead, such prior art systems typically use whatever available bandwidth or sub-channels happen to be usable at that instant in time.

20 Similarly, while a fixed 300 baud rate downstream modem can work with an upstream 33kbs rate modem this arrangement is also unlike the present invention. This is because, again, the bandwidth reduction in such prior art device is so large that it is considered commercially unusable by today's standards. Furthermore, the smaller bandwidth modem is not compatible with, and does not support, the higher protocols of the higher bandwidth modem, which is also undesirable from an implementation standpoint. Stated another way, unlike the present invention, the lower end modem limitations of prior art system force the data link to be set up using a low level protocol that does not take advantage of 25 the full capabilities of more advanced protocols.

Finally, there is no mechanism for users of either of the prior art systems noted above to expand the functionality of such modems in a controlled, flexible, and modular manner.

BRIEF DESCRIPTION OF THE DRAWINGS

30 Figure 1 is a pictorial depiction of the ADSL/DMT bandwidth allocation for upstream and downstream data in a channel based on frequency division multiplexing (FDM) configuration.
 Figure 1B shows the relationship between a sub-band filter and an analog to digital converter that can be used in an analog front end (AFE) of the present invention ;
 35 Figure 1C is a pictorial depiction of a SNR curve for a typical subscriber loop channel using sub-channel modulation;
 Figures 1D - 1G are mathematical modellings and charts that further explain the underlying physical premises of the present invention based on DMT ;
 Figure 2 is a block diagram of a general implementation of a communications system employing the present invention, adapted for use in an ADSL environment ;
 40 Figure 3A is a block diagram of a dedicated hardware implementation of a communications system employing the present invention, also adapted for use in an ADSL environment;
 Figure 3B is a block diagram of a mixed hardware and software based implementation of a communications system employing the present invention, also adapted for use in an ADSL environment;
 45 Figure 4 is a block diagram depicting the general structure of the data pump device driver used in the mixed implementation shown in Fig. 3;
 Figure 5 is a flowchart depicting the general operation of the control and application interface used in the mixed implementation shown in Fig. 3 ;
 Figure 6 is a block diagram of an implementation of a communications system employing the present invention, also adapted for use in an ADSL environment, in which it is depicted how a user can modularly expand throughput 50 capability by adding additional AFE stages to process a greater percentage of the available bandwidth in the channel.

DETAILED DESCRIPTION OF THE INVENTION

55 While some of the concepts set forth immediately below are well-known, a brief explanation of ADSL technology is provided with reference to Figure 1 to facilitate an understanding of the present invention. As explained above, it is well-known in the art to use DMT to effectuate the ADSL standard. In contrast to most modulation schemes, such as AM/FM

transmissions that use one carrier, DMT uses multiple carriers to transmit data bits. Specifically, T1E1.4 ADSL standards specify an up to 255 channels for downstream transmission from the central office to subscribers and up to 31 channels for upstream transmission from subscribers to the central office. As shown in Figure 1, each carrier has a bandwidth of 4.3125 kHz. The total bandwidth is 1.1 MHz for a total of 255 channels. In the upstream direction, a "pilot" tone in the approximate range of 69 kHz, is used for maintaining timing synchronization. A similar pilot tone is transmitted in the downstream direction in the vicinity of 276 kHz.

Since upstream and downstream transmissions are over the same 2-pair twisted wire, they need to be separated by either echo cancellation (EC) or frequency division multiplexing (FDM). Echo cancellation allows simultaneous transmissions in both directions but requires a complex echo canceler implementation. On the other hand, FDM uses two different frequency bands for separate downstream and upstream transmissions. As shown in Figure 1, the upstream transmission uses subchannels from channel number 6 to 31, and the downstream transmission uses subchannels from channel number 41 to 255. While the remainder of the discussion below focuses on a system employing FDM, it will be appreciated by those skilled in the art that the present invention is adaptable and can be used beneficially with echo-cancellation approaches as well.

As with most communication environments, the transmission bit rates for both upstream and downstream communications in ADSL are not fixed but instead are determined by the quality of the channel. In the present invention, a number of well-known techniques can be used advantageously for setting up the initial data link. In general, these techniques work as follows: during initialization, the channel quality is measured and a certain data rate (typically a number of bits) is assigned for each DMT subchannel; thereafter, a "hand-shaking" process is used to dynamically and adaptively change the bit loadings (and energy levels). The latter is often necessary because (among other things) changes may occur in the overall channel characteristics, changes in the target bit rate may be needed, or new bit distributions in the sub-channels may be required because of degradations in one of the sub-channels.

The quality of the sub-channel response can be measured by the received signal to noise (SNR) ratio. According to the Shannon theorem, the upper limit of the number of bits per unit Hz that can be transmitted is $\log_2(1+\text{SNR})$. Therefore, by measuring the received SNR at the receiver end, one can determine the number of bits allocated for each subchannel modulation. The total data throughput rate achieved by the system, therefore, is simply the sum of all the data rates of all the usable subchannels.

According to the T1 E1.4 ADSL standards, data bits are grouped and processed every 250 μsec . The number of bits that can be processed over one such time frame is the summation of the bits allocated for each subchannel determined from the previous channel response measurement. For a given number of bits assigned to a certain subchannel, quadrature amplitude modulation (QAM) is used to convert bits to a complex value, which is then modulated by the subchannel carrier at the corresponding frequency.

The above is a merely a brief summary of the general operation of a typical DMT/ADSL communications system. The general circuits used in prior art ADSL systems, the specifics of the bit/energy loading process for the sub-channels, the bit fine tuning process, and the details of the modulation of the sub-channels, are well-known in the art, and will not be discussed at length herein except where such structures or procedures have been modified in accordance with the teachings herein.

The full downstream data throughput of a typical prior art ADSL standard transceiver approaches 6 Mbps, which is more than 200 times the speed of conventional analog modem technology. This requirement was imposed since a large part of the initial motivation to implement ADSL was to achieve high speed multimedia communications and video teleconferencing. Nevertheless, a large number of potential users do not want or need to have such wide bandwidth capability. For example, many potential users of ADSL (or similar high speed loops), including many who are intending to use such links primarily for Internet access, only need to achieve downstream transmission speeds that are in the hundreds of kilobits per second range. This data rate is in fact achievable using only a fraction of the available bandwidth of ADSL. By processing only a fraction of the available bandwidth of the ADSL standard, the present invention permits a limited but extremely useful ADSL modem to be implemented with significantly less expense and complexity than previously possible. At the same time, because the present invention has modular characteristics, the proposed implementation of the present invention affords users an easy path to forward and upward expansion of the overall functionality of their system.

The principle behind this aspect of the present invention is as follows: As shown in Fig. 1B, if the transmission in the channel is restricted to a smaller bandwidth by an anti-aliasing filter 80, according to the Nyquist sampling theorem, the sampling rate of AFE devices (such as ADC 81) that perform analog to digital conversion can be significantly reduced. Specifically, if the total downstream bandwidth is limited to some fractional total B Hz (in a preferred embodiment using DMT in an ADSL environment, $B = 20$ DMT channels or about 86 kHz) as shown below, we can limit the Nyquist sampling rate to around 180 kHz. This is achievable with ADCs having greatly simplified hardware and reduced performance requirements, in contrast to the full ADSL bandwidth approach, which processes 200 DMT channels or 900 kHz in the case of full ADSL implementation.

The total accumulated bit rate of an ADSL communications system using the present invention can be calculated

EP 0 889 615 A2

as follows. Suppose a total number of k subchannels (out of a total of M possible) are to be supported and each channel is allocated b_k bits for transmission. The total accumulated bit rate (R) is:

$$R = \left(\sum_{i=1,k} b_i \right) * 4 \text{ kHz (bits/sec)}$$

5

where 4 kHz is the framing rate defined by T1E1.4 ADSL standards. If $k=20$ channels and the average number of bits per channel is 6, then total bit rate (R) is approximately 480 kbits/sec. It can be seen that this fractional use of the ADSL bandwidth nevertheless provides about 9 times the performance of a conventional analog 56 kbits/sec digital modem. The benefits of this approach of the present invention are apparent. The overall performance and cost of a high speed communications system can be scaled and controlled in direct relationship to the particular needs of particular users. In general, the data rate supportable by (and the relative cost of) any particular implementation of the present invention is generally determined by two factors: (1) the capacity of the AFE; and (2) the capacity of the hardware performing the DMT.

10

15

The capacity of an AFE is generally measured by the maximum sampling speed it can achieve. As explained above, the sampling speed in turn determines the upper limit of the frequency band B (in kHz) that can be obtained. At the defined channel separation of 4.3125 kHz for ADSL, the total number of subchannels that can be supported is less than or equal to $B/4.1325$. A suitable ADC can be selected, therefore, based on the particular data rate and cost requirements of any particular user.

20

25

The other factor that limits the number of subchannels (and achievable data rate) is the processing power available for DMT modulation and demodulation routines. For example, a variety of performance levels (achievable data rates) are possible with well-known dedicated signal processing hardware, such as digital signal processors, as discussed in more detail below with reference to Figure 2. Alternatively, as shown in Figure 3, if such routines are implemented primarily by software and run by a host CPU, the required processing power (MIPS) generally increases directly as function of the number of subchannels that need to be processed. This is because, in general, most of the processings are done in serial, or a channel by channel basis. As discussed below in more detail, the present invention makes use of a "calibration" routine for estimating the total available processing power of a users computing system in order to set an upper limit of the total subchannels that can be supported.

30

35

Irrespective of the selection of the particular AFE or signal processing technique used, however, another useful (but not essential) aspect of the present invention is that the sub-channels with the largest signal to noise ratio (SNR) within the passband are selected for data transmission. In other words, in the preferred embodiment of the present invention, those k subchannels within the passband that support the largest number of bits are used for processing. As seen in Fig. 1C, for example, a standard two-wire subscriber line typically has a SNR curve that exhibits extensive attenuation with higher frequencies. It can be seen roughly in this figure that while there are more than 200 sub-channels provided for downstream transmission in ADSL, it is typically the case that 50% of the maximum data rate can be accomplished using only a much smaller percentage (than 50%) of the sub-channels. This fact is especially useful in considering some of the shared/ multi-channel bandwidth embodiments discussed further below.

40

45

The present invention, therefore, permits an implementation for a high speed data communications system that makes use of the best portion of the channel, while still being upwardly compatible and forward expandable. By these terms, it is meant that a system constructed in accordance with the teachings herein is completely compatible with a fully implemented version ADSL DMT modem. Moreover, it will be apparent to those skilled in the art that appropriate modifications specific to the channel and data link protocols and standards can be made so that the present invention can be advantageously employed in non-ADSL environments as well. Upward compatibility and forward expandability refer to the fact that systems constructed with the present teachings can have data rates that are easily upgraded while still preserving and maintaining compatibility with existing standards. For example, lower end users desiring less bandwidth can achieve a satisfactory performance with a minimum of cost, and can then upgrade the performance levels of their systems at later time by suitable (and preferably modular) upgrades of the AFE and signal processing hardware/software.

50

55

A system constructed in accordance with the present teachings is completely compatible with the full ADSL standard because of the following two aspects: According to the rate adaptation feature specified by the T1E1.4 ADSL standards, the bit rate for each sub-channel is determined initially (and preferably dynamically on an ongoing basis) by the sub-channel SNR analysis. Specifically, an ADSL downstream receiver can inform an upstream ADSL transmitter about the quality of the transmission; the receiver can also decide the bit rate for each sub-channel. Therefore, a downstream, partial-channel bandwidth receiver using the present invention can (based on the speed and passband of such receiver) supply an upstream, full-standard ADSL transmitter with information or control signals to effectuate a transmission only in selected sub-channels. In particular, in a preferred embodiment, the upstream ADSL transmitter is provided with SNR information for sub-channels outside the passband that is artificially contrived so as to suggest to the upstream transmitter that these sub-channels are not usable. In this manner, the downstream transmission is limited to a certain number of subchannels within the AFE and signal processing capabilities of the receiver. It can be seen, nev-

ertheless, that this scheme is completely transparent to the transmitter, thereby permitting a system built in accordance with the present teachings to be fully compatible with the ADSL standard. While not possible at this time within the ADSL standard, it is apparent that other high-speed data protocols may use a control signal, instead, to provide for express limiting and control of the identity of the sub-channels transmitting information.

5 As the technology improves for AFE devices and DMT implementation, the number of subchannels supported by a system using the present invention can increase. As a result, such systems can upgrade completely to a full T1E1.4 ADSL implementation using a single higher end modular replacement APE devices, or alternatively, a number of lower end modular AFE devices.

10 GENERAL EMBODIMENT OF PRESENT INVENTION

The basic structure of the present invention is depicted generally in Fig. 2. In general, the present invention can be embodied in different combinations of hardware and software. The primary difference between these embodiments is the specific implementation of the DMT core. These specific embodiments are described in more detail below with reference to Figs. 3A and 3B.

15 The structure and operation of ADSL transceivers is well-known in the art, and for that reason the present description primarily details those aspects of such transceivers which are necessary to an understanding of the inventions herein. As seen in Fig. 2, a channel 100 is made of a regular copper wire "loop", and each such loop may have differing electrical properties, transmission lengths (sizes), varying attenuation characteristics, and a number of impairments or interferences. Splitter 210, a conventional and well-known circuit, separates a DMT signal occupying more than 200 sub-channels from a lower end 4 kHz POTS analog signal. The latter can be used for simultaneous voice or conventional analog modem. Hybrid circuit 220 is also well-known in the art, and consists primarily of conventional transformers and isolation circuitry used in a wide variety of high-speed devices interfacing to standard telephone lines. A ring detect logic circuit 290 can also be implemented using accepted techniques, to alert a Control Interface 295 to the existence of a transmission signal originating from an upstream transceiver (not shown).

25 The full bandwidth signal is either low passed or bandpass limited to a frequency width B by suitable, well-known techniques as it passes through bandpass Filter and Analog/Digital Converter 280, so that only a fraction of the signal in the frequency domain is passed on to Buffer and DMT Receive Core 260. Again, the only important consideration for Subband Filter 280 is that it must constrain the bandwidth of the incoming signal to be $\leq B$, where the sampling rate of the Analog/Digital Converter is $\geq 2B$. This can be accomplished by using well-known filter designs. By suitable selection of circuitry for Filter and ADC 280, the overall system cost and performance can be scaled accordingly. In a preferred embodiment, the signal passed through Filter and ADC 280 occupies a spectrum between approximately 200 and 400 kHz. This selection is based primarily on an expected average performance of a typical two-wire line. It will be apparent to those skilled in the art that different bandpass widths and regions may be more suitable or optimal for other kinds of data links, or other kinds of multi-carrier modulation schemes.

30 Moreover, in some instances, while it is somewhat more expensive to implement, an adaptive or tunable filter may be substituted, such that the target frequencies of the passband are adjustable uniquely for each new data link. In such cases, the bandpass can be configured to coincide with the sub-channels having the highest achievable SNR, including the subchannels that must be supported for protocol or other system overhead reasons. Also, in some applications, the analog-to-digital conversion may be performed by a digital signal processor, or by the host computer and therefore, the sampling rate can be dynamically controlled and matched to the bandpass target frequency and frequency breadth. This feature, in turn, would assist dynamic scaling of the data throughput based on system computing power and overhead requirements.

35 Furthermore, in this preferred embodiment, using a multi-carrier approach implementation for ADSL, a pilot tone at 276 kHz must be allowed within the passband. It is apparent that other protocols may require similar pilot tones, and the design of comparable filters to achieve the functionality of Filter and ADC 280 is well within the ordinary skill of one in the art.

40 DMT Receiver Core 260 is generally responsible for monitoring and measuring the SNR of the sub-channels falling within the frequency range passed by FILTER and ADC 280, and for extracting the original data stream from the numerous sub-carriers. In a preferred embodiment, Control Interface 295 receives system configuration information from a host 298. This information may contain such parameters as target throughput rate R, target error rate, target center frequencies F for FILTER and ADC 280, target frequency width B, etc. By evaluating the SNR and bit capacities of the sub-channels computed by DMT Receiver Core 260, and taking into consideration the target data rate R, Control Interface 295 can select a number k of sub-channels up to and including the total available number M of sub-channels to carry the data stream from the upstream transmitter (not shown). The number of sub-channels that can be used for carrying data is directly related to the bandpass frequency B as described above. In a preferred embodiment, $M = 200+$ (ADSL) and Control Interface 295 will usually configure $k = 20$.

45 For every sub-channel other than the selected k sub-channels, a "mask" or blackout control/feedback signal is gen-

erated and transmitted by DMT Tx Core 250, Buffer 260 and DAC 230 to the upstream transceiver. This ensures that any subsequent data transmissions by the upstream transceiver only use the selected k sub-channels. This feedback information is provided, therefore, irrespective of the transmitting capacity of the upstream transceiver, and even during times when the channel 100 is capable of supporting more than k sub-channels. In this manner, the present system is perceived by upstream transceiver to be compatible with protocols and performance characteristics of the upstream transceiver, because the upstream transmitter receives feedback information indicating merely that the two systems are connected through a channel with substantial signal attenuation characteristics for data signals outside the k sub-channels. Based on the inherent rate adaptiveness of ADSL and other similar protocols, the upstream transceiver will automatically train itself to use only the k sub-channels predetermined by the downstream transceiver. It should be noted that the DAC 230 and Buffer 240 in the front end transmitting circuit preferably transmit any upstream data transmissions using a second frequency bandwidth different from that of the downstream data transmission. However, this is not necessary in systems using echo-cancellation. Furthermore, in ADSL applications, the size of this bandwidth is considerably smaller, and uses only L sub-channels, where $L < M$. In other xDSL applications, L may be on the same order or larger than M .

Again, while the ADSL standard fixes the data error rate to be 10^{-7} , it is conceivable that other applications of the present invention may tolerate a reduced error rate. For example, if maximum data throughput is required (i.e., the margin is less constrained) then the largest bit capacity sub-channels within B can be selected. Alternatively, if the system is error-performance driven and has more relaxed throughput requirements, then the 20 subchannels with the best margin are selected. A suitable combination of sub-channels can be selected by one skilled in the art based on the particular system requirements which may vary from application to application. Moreover, Controller Interface 295 may optimize the desired sub-channel mix dynamically depending on the type of data transmitted in channel 100. For example, streaming audio or video, or pictorial graphics, may require less integrity and error performance than other kinds of data used by n applications programs running on host 298. The specifics of the structure, operations and techniques used by Controller Interface 295 are not constrained by any requirements of the present invention, and can be implemented in various ways well-known to those skilled in the art.

The operation of the remainder of the circuitry shown in Fig. 2 is also relatively straightforward and not unlike a typical multi-carrier modulation system. Control Interface 295 ensures that DMT Transmit Core 250 performs bit and energy loading only for those sub-carriers necessary to effectuate a selected host throughput rate/error rate combination. As with the circuitry used for Filter ADC 280, the circuitry for performing the functions of DAC 230 can be implemented in programmable form to allow for greater flexibility.

Finally, while not presently supported in ADSL protocols, it is nevertheless possible that the filter in block 280 can be eliminated entirely in some applications when the sub-channel or downstream transmission frequencies can be configured through appropriate handshaking or similar procedures. In other words, if the upstream transmitter can be configured to transmit using only a portion of the bandwidth available in the channel, the advantages of the present invention can still be realized, because the ADC portion of block 280 can still be relatively less complex, since it will be processing at a much slower sampling rate than that required for a full spectrum implementation. Moreover, such an implementation would also yield the same commensurate savings in the DMT processing core, and reduced quantization errors.

Some special features of the present invention include the fact that:

(i) unlike hardware architectures implementing a full T1E1.4 ADSL standard, the present invention uses a filter in the front end. As mentioned earlier, the use of this filter is to allow low speed sampling by the ADC. If suitable handshaking between the upstream and downstream transceivers can be effectuated to generate a reduced downstream transmission, the filter can be eliminated.

(ii) standard ring detection logic is incorporated to support existing modem features;

(ii) DMT Rx core 260 is basically implemented the same way as specified by T1E1.4, but with some important differences, specifically:

[a] due to subband filtering and lower speed sampling, the frequency channels at the output of FFT (not shown) in the DMT Rx Core have a frequency shift

[b] Since not all 256 subchannels are necessarily supported by the DMT Rx Core 260, actual FFT implementation can be smaller, simpler and more cost-effective;

(iv) Control logic 295 permits the system to behave essentially like a conventional analog modem, and is used to support necessary setup tasks such as dialing and handshaking;

(v) The use of limited bandwidth from the downstream channel reduces the need for echo-cancellation circuitry, because there is less need for overlap between the upstream and downstream transmissions, and this further reduces system complexity and cost;

(vi) Because a smaller portion of the spectrum is processed by the present invention, the peak-to-peak deviation of the downstream signal is reduced, and this helps to minimize quantization errors.

DEDICATED HARDWARE BASED EMBODIMENT

5

Figure 3A illustrates an embodiment of the present invention that can be generally described as a dedicated hardware implementation. For the present discussion of Fig. 3A, it can be assumed that those circuits having like numbered references are the same and/or perform the same function as their counterpart in Fig. 2. For example, unless otherwise indicated, there is no material difference between Splitter 210 (Fig. 2) and Splitter 310 (Fig. 3A).

10

In this embodiment, the DMT sub-channel modulation core is implemented completely in dedicated processing hardware. For thin application, DMT Receiver Core 260 typically includes a digital signal processor (DSP) (not shown) and including on-board program ROM (or other suitable memory) for storing executable microcode routines for performing bit, energy and SNR measurements of the carriers in the sub-channels. In such an embodiment, due to the power of the DSP, there is typically no need for processing assistance from a user's host processor 398. This embodiment therefore may be advantageously employed where host processing power limitations are a consideration.

15

A user of a system shown in Fig. 3A can expand the functionality (i.e., data throughput rate and modem features) of such system by upgrading the DMT Receiver Core 260, and where necessary, the AFE 280 as well. The system of Fig. 3A can be incorporated on a typical printed circuit board. By mounting or packaging the circuits used in such blocks in an accessible fashion, they can be replaced or supplemented much in the same way present users of personal computers can upgrade their motherboards to include additional DRAM. One practical alternative, for example, would be to have multiple available slots to accommodate new subband pass filters for passing a greater portion of the downstream transmission to be processed by the DMT core logic. Other practical and simple variations of this approach will be apparent to those skilled in the art.

20

25 PARTIAL SOFTWARE BASED EMBODIMENT

In the above dedicated hardware embodiment, the overall speed (data throughput) can be maximized but with less flexibility for upgrades. This is because upgrades to such a system must take the form of hardware replacements, which can be more costly and difficult for the user to incorporate. On the other hand, as depicted in Fig. 3B, a number of important functions of a communications system can be completely implemented in software, in an analogous fashion to what is commonly described in the art as a "software" modem. In this case, the overall speed of the system depends on the user's processor power available at host 398, and only the AFE portion need be implemented in hardware.

30

The primary differences between the embodiments of Fig. 3A and 3B are the following: (1) implementation of DMT modulation; (2) implementation of the control and handshaking functions; and (3) implementation of the control interface. As seen in Figures 3B and 4, DMT Receive Core 460 and DMT Transmit Core 450 are implemented in a data pump device driver by the host system 398. In a preferred embodiment, host system 398 includes some form of multi-purpose microprocessor (such as an x86 type processor) running a suitable operating system (such as Windows by Microsoft), and is capable of executing suitable low level drivers for the DMT modulation (Fig. 4), as well as high level application software for implementing Control Interface 500 (Fig. 5). Host processor system 398 communicates over a standard bus interface 385 (i.e., a PCI bus) to Front End circuitry 396 for implementing a high speed modem. As with the circuitry in conventional analog modems, this circuitry of the present invention can be effectively incorporated on a PC motherboard (i.e., Bus Interface 385 and Front End Circuitry 396 can be merged so that they are essentially part of host system 398) or on a separate printed circuit board, or as a stand-alone unit physically separated from host 398. While this approach may not provide as much throughput performance, it has the advantage of being less expensive than the pure hardware approach of Fig. 2, and much easier to upgrade.

35

40

45

In the "software" modem implementation of Fig. 3 using a typical PC running Windows, the DMT Tx core 450, Rx Core 460 and Control/Handshaking logic are implemented as a Windows Data Pump Device Driver 400, which consist of DMT routines, associated control and handshaking codes, and an interface to kernel 480.

50

A more detailed characterization of a portion of host processing system 398 is depicted in Fig. 4, which illustrates a preferred embodiment of a device driver 400 as it would be constituted for a computer operating system shell 480. In the present embodiment, Microsoft Windows NT is considered, but it is understood that other comparable environments may be used, including UNIX, Windows 95, etc. As is well-known, operating system 480 is responsible for supervising and controlling the operation of processing system 398 and all of its associated peripheral devices. Operating system 480 also includes various interactive control and graphical application interfaces (Fig. 5) for permitting a user of processing system 398 to run various applications programs, and to set up, control, configure, monitor and utilize peripheral devices such as disk drives, printers, monitors, modems and the like.

55

To assist operating system 480 to interact and control such peripheral devices, it is also well-known to use device drivers, which are essentially low-level hardware routines executed by a host processor and operating system. A device

driver is a memory image file or executable file that contains all the code necessary to instruct a host processor to interface and drive a particular device within a computing system. Device driver 400 acts as an interface between an operating system 480 (in this case, Microsoft Windows NT) and hardware 396. In this case, for example, device driver 400 supports hardware 396 (see Fig. 3B), which is embodied in a typical printed circuit board (or external device). The teachings herein therefore provide for a new device driver that in combination with hardware 396 operates as a "software" modem. In this manner, operating system 480 classifies this combination as an ADSL modem, or in other words, another typical personal computer peripheral device, analogous to conventional voice-band modems.

Generally speaking, device driver 400 works as follows: a user of processing system 398 desiring to establish a data link to a remote site for transmitting/receiving data initiates such link through an application program (Fig. 5). Operating system 480 (Fig. 4) interprets and services this request by passing control of this task to device driver 400, which first generates appropriate instructions for a Device Initialization 440. In a preferred embodiment, Modem card 396 is initialized through Bus Interface 410 using conventional voice band modem control commands, so that the present invention is compatible with preexisting applications programs written for controlling modems using operating system 480. Similarly, therefore, control and data signals are interpreted and transmitted by operating system 480 to a Serial Port Interface 475 so that conventional modem dialing instructions and handshaking signals can be imparted to Modem Card 396 to establish a link through channel 100 to an upstream conventional ADSL transceiver (not shown). As explained above, after suitable handshaking protocols have been completed, the upstream fully compatible ADSL transceiver will begin transmitting data on all available M usable sub-channels. This downstream data is filtered by FILTER/ADC 380 and at this time, information for only N sub-channels ($N \leq M$) is temporarily held in Buffer 370. At or before this same time, an interrupt is generated by bus interface 385 and passed through device driver bus interface 410 to alert Interrupt Service Router 415 to the existence of downstream data requiring processing. Thereafter, DMT Receive Core 460 begins processing the downstream data stream in response to control information from ISR 415. A demultiplexer 465 extracts and correlates the data in the various sub-channels before passing it on to Serial Port Interface 470, and back to Operating System 480. In this manner, Device Driver 400 coordinates with Modem card 396 to effectuate a software modem whose performance is directly correlated to the computing power of a processor contained within the host processing device.

As mentioned earlier, Device Driver 400 also contains control information for configuring the number and selection of sub-channels to be used in the particular data link established through channel 100 with the upstream transceiver during an initialization process. As also mentioned above, this control information may be self-determined by a user of host processing system 398, or alternatively, automatically sensed and monitored by such processing system, based on a computing performance rating for such system determined in a calibration routine. In either event, during the initialization process (and at all times subsequent) the upstream transceiver is induced to use such sub-channels only for the ensuing data transmission. This is accomplished by transmitting SNR information that is interpreted by the upstream transceiver as zero for all but $K \leq N$ of the sub-channels of the driver selection. This data is passed under control of Operating System 480 through Serial Port 475, Framing control 455 and DMT Transmit Core 450 before being sent out to Modem Card 396 and channel 100.

It is understood, of course, that ADSL Modem 396 can also respond to a request from a remote modem for initiating the data link. The process for initializing the link, nevertheless, is essentially the same as that described above. Device driver 400 can also contain control logic for supporting typical dial-up modem operations and control codes from conventional modem application programs typically implemented in voice-band modems, such as setting up Originate/Answer modes, monitoring call progress, performing modem diagnostics, configuring receive/transmit buffer sizes, supporting facsimile transmissions, as well as performing enhanced error control, data compression and flow control between Modem Card 396 and Operating System 480. Device Driver 400 can also support other conventional "always-on" data link connections as desired, such as may be found in typical ethernet network connections, and other dedicated applications.

Given the teachings of the present invention, the general design of the above Data Pump Device Driver 400 is a routine task well within the abilities of one skilled in the art. The specifics of such implementation are not critical or essential to the present inventions, and will vary from application to application according to system designer requirements, so they are not included here. Again, while this embodiment of the present invention is set out in the context of a PC based host processor running Windows, it will be apparent to those skilled in the art that above description is merely an exemplary implementation. The referenced DMT routines, associated control and handshaking codes can be employed in numerous host processing/operating system environments, and in a variety of different coding organizations (high level or low level processing forms) well-known in the

In the preferred embodiment implemented using a standard PC running Windows, Control/Application interface 500 includes Win32 codes which provide standard modem utility functions and interface with Data Pump Device Driver 400. In Fig. 5, a flowchart of the operation of the Control/Application Interface 500 can be seen, which interface is discussed in more detail below.

Another particularly beneficial aspect of the embodiment of Fig. 3B is the provision of a self-determining "perform-

ance" or calibration rating that can be used to determine an optimal or maximum data throughput rate. In other words, the system of Fig. 3B can automatically and adaptively configure a host system 398 to a particular throughput rate based on an evaluation of the available computing power. In a preferred embodiment, the performance rating is determined based on a calibration routine executed by Data Pump Device Driver 400. This routine sets a timer, and counts how many DMT frames can be processed within the given time; this gives a relative figure of merit for the particular host system in question. For each sub-channel to be added, one DMT frame needs to be processed within a small fraction of 250 μ s. Therefore, by incrementally increasing the sub-channel count, the overall effect on total system processing overhead can be determined. Control/Application Interface 500 provides the user with control to set a threshold of available host power for implementing the high speed link. Based on this threshold of available power (which can be nominally set to 20%) the number of subchannels that can be supported can be gleaned very quickly.

In view of current technology, when DMT processing is implemented in software, the host processing power is more likely to be the limiting factor than the frequency band of the subband filter 80 in Figure 1B. Nevertheless, because host processors (and especially microprocessors) are evolving in performance at a fairly rapid rate, the present invention affords users an opportunity to realize a high speed data link with performance that is controllable, and which improves whenever there is an upgrade in the host processing system. Since many typical present day personal computer systems have easily accessible and replaceable host processors, users of the present invention can easily and flexibly expand and enhance the throughput and functionality of an ADSL modem.

An example of the flow chart for an ADSL modem application/control program 500 designed in accordance with the present teachings is shown in Fig. 5. With the teachings herein, a user of host processing system 398 can, for the first time, dynamically control a forward compatible and expandable modem, such as an ADSL modem, using modem-control applications software that is analogous to that only previously available for voice band modems. In a preferred embodiment, ADSL Modem Card 396 is automatically detected by Operating System 480 and set up by initialization routine 505 by Modem Device Driver 400. A separate detection routine 510 determines whether or not ADSL Modem Card 396 has been upgraded with an additional AFE (as described generally with reference to Figure 6 below), or alternatively whether a processor used in a host system has changed. The purpose of this step is primarily to determine whether entries in a Device Parameters Table 560 need to be updated because of changes in computing power, front end capabilities or other parameters that may necessitate a modification of the data throughput characterization of the overall system when used in a communications mode.

A calibration routine 520 is then executed to determine the nominal setup parameters for the overall system in the manner described earlier. The results from this operation are stored in Device Parameter Table 560 where they then become accessible to various application programs that may make use of ADSL Modem Card 396 and Device Driver 400. The information stored in table 560 can include any or all of the following (a) measurements of the computing power available to the host processor; (b) measurements of the number of frames processable by the system within a particular time period; (c) estimations of the expected loading on the processing system based on demands of other applications programs and peripheral devices; (d) minimum and maximum data throughput estimations and/or targets; (e) data identifying the type of host processor; (f) data identifying the number and type of AFEs in ADSL Modem card 396; (g) estimations and/or target system loading rates available for a datalink (i.e., maximum available processing time to be used by the system during data transmission); (h) data transmit and receive buffer sizes; (i) interrupt or similar priority data for the modem card; (j) estimations and/or target system sub-channel utilization; (k) estimations and/or target system sub-channel bit capacity information; etc. It will be apparent to skilled artisans that the above are just examples of the types of information that may be pertinent to the performance of a high speed communications system, and that other parameters may be considered depending on the environment, application, etc. in which the present invention is used.

After performing Auto Calibration routine 520, the results of the same are presented to the user for acceptance and verification at step 525. At this point, the user can accept the predetermined configuration data at step 526 (i.e., such as proposed maximum and minimum throughput rates, loading rates, etc.) and this would otherwise invoke an end of modem setup routine 590. Should the user not want to accept the recommended parameters, a Manual Configuration routine 530 is executed. At this juncture, various system performance data can be presented to the user for review, along with a list of modifiable system options 532. If for example, the user elects to increase the desired throughput rate, a Verification routine 540 is then executed to determine whether such rate is reasonably sustainable within the other parameters of the system. If the new proposed configuration data is otherwise acceptable, then the Device Parameter Table 560 is updated, and the setup routine again ends. Otherwise, the user is alerted by a Notification/Suggestion routine 550, which points out the failure of the proposed configuration, and, if possible, makes suggestions to the user for modifying the system options 532 so that overall compliance can be achieved within the performance capability of the host processing system. The program then loops back to Acceptance routine 525, and thereafter the process is repeated until an acceptable configuration has been achieved, and any changes have been incorporated into Device Parameter Table 560.

While some of the operational steps above are described as implemented solely by Operating system 480 and

Device Driver 400, it is understood that such operations occur under direction of modem applications program 500, or in some cases, based on initialization routines executed by the host processing system. Moreover, to simplify the presentation of the present invention, only some of the features that may be implemented are described above, and many other well-known operational steps normally associated with setting up or monitoring modems are omitted.

5 As with the design of the above Data Pump Device Driver 400, the general design of the Control/Application Interface 500 required to accomplish the above functions is a routine task well within the abilities of one skilled in the art given the teachings herein. The specifics of such implementation are not critical or essential to the present inventions, and will vary from application to application according to system designer requirements, so they are not included here. Again, while this embodiment of the present invention is set out in the context of a PC based host processor running
 10 Windows, it will be apparent to those skilled in the art that above description is merely an exemplary implementation. The referenced Control/Application Interface can be employed in numerous host processing/operating system environments, and in a variety of different coding organizations (high level or low level processing forms) well-known in the art.

MULTIPLE AFE AND LOWER SAMPLING SPEED EMBODIMENT

15 Figure 6 illustrates an example of the present invention wherein a user can achieve significantly increased data throughput using multiple low cost, low sampling speed AFEs, generally designated 680A, 680B, 680C, etc. As described above, these AFEs may be in separate, modular form and configured in a bank form so that they can be incorporated conveniently on a printed circuit board (or similar mounting) or integrated in a single IC chip. Each AFE
 20 can be implemented in a fixed hardware configuration, or individually programmed/controlled to pass a certain portion of the downstream data transmission. Assuming suitable processing power is available for DMT modulation/demodulation (either through a dedicated or software implementation as described above in connection with Figs. 3A and 3B) a user of such system can achieve substantially expanded functionality by upgrades having performance characteristics and costs of their choice.

UNDERLYING THEORY OF PRESENT INVENTION FOR ADSL/DMT APPLICATIONS

25 A discussion of the underlying theory supporting the premise of the present invention now follows. In particular, this section shows the mathematical foundation For the use of multiple low speed AFE's to sample a full bandwidth ADSL/DMT signal. It will be apparent to those skilled in the art, after reading this discussion, that the present inventions can be advantageously used in a number of rate adaptable communications environments, including CAP implementations of ADSL.

DMT Transmitter

35 To simplify the present discussion, only a subset of the DMT transmitter is considered, as shown in Figs 1D and 1E. The combined model that includes the channel response and the DMT receiver is shown below, where only one branch of band-pass filtering and sampling is shown for simplicity. To further simplify, the channel response and the SFIR are combined together.

40 In this subsection, we analyze the signal over one band pass filtering process. The result shows that the DMT signals within the band pass can be recovered with the same use of impulse response shortening technique. With use of multiple AFE's that cover different frequency bands, all DMT subchannels can be recovered. IFFT

In an ADSL environment as shown in Fig. 1D, N ($N=512$) frequency domain variables are transformed into the time domain by IFFT block 60

45

$$y_n = \sum_{i=0}^{N-1} x_n e^{j2\pi i n / N}$$

Cyclic Prefix

50 c time domain variables at the end are added to the prefix of the sequence as shown in Fig. 1D by block 70 $\{z_n\}=\{z_{-c}, z_{-c+1}, \dots, z_{-1}, z_0, z_1, \dots, z_{N-1}\}=\{y_{N-c}, \dots, y_{N-1}, y_0, \dots, y_{N-1}\}$

AFE/DAC

Discrete time domain sequence are converted by AFE 75 to the continuous time domain waveform as follows:

EP 0 889 615 A2

$$z(t) = \sum_{n=-\infty}^{\infty} z_n \rho_{TX}(t-nT_c),$$

5 where $\rho_{TX}(t)$ is the transmitter pulse of the AFE/DAC used, and T_c is the transmitter DAC dock period and equal to

$$T_c = \frac{250 \mu\text{sec}}{N+c}$$

10 according to the DMT ADSL specifications.

Channel

With reference now to Fig. 1E, if the channel impulse response is $h_c(t)$, we have

15

$$u(t) = \sum_{n=-\infty}^{\infty} z_n \rho_{RX}(t-nT_c)$$

20 where $\rho_{RX}(t) = \rho_{TX}(t) \otimes h_c(t)$.

Bandpass Filtering

If the bandpass filter 80 has an impulse response of

25

$$h_{BPF}(t), v(t) = \sum_{n=-\infty}^{\infty} z_n \rho_{BPF}(t-nT_c)$$

30 where $\rho_{BPF}(t) = \rho_{RX}(t) \otimes h_{BPF}(t)$.

AFE/ADC

Let the sampling clock be $T_s = T_c \times L$. This means a slower sampling by a factor of L for AFE 81. Thus,

35

$$w_k = \sum_{n=-\infty}^{\infty} z_n \rho_{BPF}(kT_s - nT_c) = \sum_{n=-\infty}^{\infty} z_n \rho_{BPF}([kL - n]T_c)$$

40 For causal pulse $\rho_{BPF}(t)$, we have

$$w_k = \sum_{n=-\infty}^{\infty} z_n \rho_{BPF}((kL - n)T_c) = \sum_{n=0}^{\infty} z_{kL-n} \rho_{BPF}(nT_c)$$

45

Shortening FIR (SFIR)

After AFE discrete time sampling, a time domain equalizer (TEQ) called SFIR 82 is used to reduce the combined discrete time impulse response to a duration smaller than c . If the SFIR response is $h_{SFIR}[n]$, we have

50

55

$$\begin{aligned}
 r_k &= \sum_{i=0}^{\infty} w_{k-i} h_{SFIR}[i] \\
 &= \sum_{i=0}^{\infty} \left[\sum_{n=-\infty}^{\infty} z_n p_{BPF}([kL-n-iL]T_c) \right] h_{SFIR}[i] \\
 &= \sum_{n=-\infty}^{\infty} z_n h_{tot}[kL-n] \\
 &= \sum_{n=0}^{\infty} z_{kL-n} h_{tot}[n]
 \end{aligned}$$

where

$$h_{tot}[kL-n] = \sum_{i=0}^{\infty} h_{SFIR}[i] p_{BPF}([kL-n-iL]T_c)$$

20 **Physical Meaning of $h_{tot}[n]$**

If we perform discrete Fourier transform at block 84 for $h_{tot}[n]$, we obtain $H_{tot}[\omega] = H_{SFIR}[L\omega] H_{BPF}[\omega]$ where $H_{SFIR}[L\omega]$ and $H_{BPF}[\omega]$ are the DFT's with period L/LT_c and $1/LT_c$, respectively. Their spectra can be illustrated as shown in Fig. 1F for $L=5$.

25

Dropping Cyclic Prefix

By dropping the cyclic prefix of length c/L , at block 83 we consider only $s_k = r_k, k=0, \dots, N_1-1$, where $N_1 = N/L$.

30 **FFT**

Performing FFT at block 84 for $s_k, k=0, \dots, (N/L)-1$, one obtains:

$$\begin{aligned}
 q_n &= \sum_{l=0}^{N_1-1} s_l e^{-j2\pi nl / N_1} \\
 &= \sum_{k=0}^{N_1-1} r_k e^{-j2\pi nk / N_1} \\
 &= \sum_{k=0}^{N_1-1} \left(\sum_{i=0}^{\infty} z_{kL-i} h_{tot}[i] \right) e^{-j2\pi nk / N_1} \\
 &= \sum_{k=0}^{N_1-1} \sum_{i=0}^{\infty} z_{kL-i} h_{tot}[i] e^{-j2\pi n(kL-i) / N_1} e^{-j2\pi ni / N_1} \\
 &= \sum_{i=0}^{\infty} \sum_{k=0}^{N_1-1} z_{kL-i} e^{-j2\pi n(kL-i) / N_1} h_{tot}[i] e^{-j2\pi ni / N_1} \\
 &= \sum_{i=0}^c \sum_{k=0}^{N_1-1} z_{kL-i} e^{-j2\pi n(kL-i) / N_1} h_{tot}[i] e^{-j2\pi ni / N_1} \\
 &= \sum_{i=0}^c \sum_{k=0}^{N_1-1} y_{kL-i} e^{-j2\pi n(kL-i) / N_1} h_{tot}[i] e^{-j2\pi ni / N_1}
 \end{aligned}$$

55

where we assume $h_{tot}[i]$ is only nonzero for $i = 0, \dots, c$. For a given i , let us define

$$l' = \lceil i/L \rceil;$$

5

We can then define $i' = l'L - i$, where $i' = 0, \dots, L-1$. Therefore, $i = l'L - i'$
 From the above definitions, we have

$$\begin{aligned} \sum_{k=0}^{N_1-1} y_{kL-i} e^{-j2\pi n(kL-i)/N_1} &= \sum_{k=0}^{l'-1} y_{kL-i} e^{-j2\pi n(kL-i)/N_1} + \sum_{k=l'}^{N_1-1} y_{kL-i} e^{-j2\pi n(kL-i)/N_1} \\ &= \sum_{k=0}^{l'-1} y_{(k-l')L+i'} e^{-j2\pi n((k-l')L+i')/N_1} + \sum_{k=l'}^{N_1-1} y_{(k-l')L+i'} e^{-j2\pi n((k-l')L+i')/N_1} \\ &= \sum_{k=0}^{l'-1} y_{(k-l'+N_1)L+i'} e^{-j2\pi n((k-l'+N_1)L+i')/N_1} + \sum_{k=0}^{N_1-1-l'} y_{kL+i'} e^{-j2\pi n(kL+i')/N_1} \\ &= \sum_{k=N_1-l'}^{N_1-1} y_{kL+i'} e^{-j2\pi n(kL+i')/N_1} + \sum_{k=0}^{N_1-1-l'} y_{kL+i'} e^{-j2\pi n(kL+i')/N_1} \\ &= \sum_{k=0}^{N_1-1} y_{kL+i'} e^{-j2\pi n(kL+i')/N_1} \end{aligned}$$

25

Therefore,

$$\begin{aligned} q_n &= \sum_{i=0}^c \sum_{k=0}^{N_1-1} y_{kL-i} e^{-j2\pi n(kL-i)/N_1} h_{tot}[i] e^{-j2\pi ni/N_1} \\ &= \sum_{i=0}^c \left[\sum_{k=0}^{N_1-1} y_{kL+i'} e^{-j2\pi n(kL+i')/N_1} \right] h_{tot}[i] e^{-j2\pi ni/N_1} \\ &= \sum_{i=0}^c \left[\sum_{k=0}^{N_1-1} \left(\sum_{l=0}^{N-1} x_l e^{j2\pi(kL+i')l/N} \right) e^{-j2\pi n(kL+i')/N_1} \right] h_{tot}[i] e^{-j2\pi ni/N_1} \\ &= \sum_{i=0}^c \left[\sum_{k=0}^{N_1-1} \sum_{l=0}^{N-1} x_l e^{j2\pi(kL+i')(l-n)/N} \right] h_{tot}[i] e^{-j2\pi ni/N_1} \\ &= \sum_{i=0}^c \left[\sum_{l=0}^{N-1} x_l \sum_{k=0}^{N_1-1} e^{j2\pi(kL+i')(l-n)/N} \right] h_{tot}[i] e^{-j2\pi ni/N_1} \end{aligned}$$

45

Since

$$\sum_{k=0}^{N_1-1} e^{j2\pi(kL+i')(l-n)/N} = 0 \text{ when } (l-n) \neq mN_1,$$

50

we have

$$q_n = N_1 \sum_{i=0}^c \left[\sum_{m=0}^{L-1} x_{mN_1+n} e^{j2\pi i' m/L} \right] h_{tot}[i] e^{-j2\pi ni/N_1}$$

55

Knowing that $h_{tot}[l]$ is zero for $l < 0$ and $l > c$, we have

$$\begin{aligned}
 q_n &= N_1 \sum_{i=0}^c \left[\sum_{m=0}^{L-1} x_{mN_1+n} e^{j2\pi i' m / L} \right] h_{tot}[i] e^{-j2\pi n i / N_1} \\
 &= N_1 \sum_{i=-\infty}^{\infty} \left[\sum_{m=0}^{L-1} x_{mN_1+n} e^{j2\pi i' m / L} \right] h_{tot}[i] e^{-j2\pi n i / N_1} \\
 &= N_1 \sum_{l=-\infty}^{\infty} \sum_{i'=0}^{L-1} \left[\sum_{m=0}^{L-1} x_{mN_1+n} e^{j2\pi i' m / L} \right] h_{tot}[lL - i'] e^{-j2\pi n (lL - i') / N} \\
 &= N_1 \sum_{m=0}^{L-1} x_{mN_1+n} \sum_{i'=0}^{L-1} e^{j2\pi i' m / L} \sum_{l=-\infty}^{\infty} h_{tot}[lL - i'] e^{-j2\pi n (lL - i') / N}
 \end{aligned}$$

Since

$$\begin{aligned}
 \sum_{l=-\infty}^{\infty} h_{tot}[lL - i'] e^{-j2\pi n (lL - i') / N} &= \sum_{l=-\infty}^{\infty} h_{tot}[lL - i'] e^{-j\omega (lL - i') T_c} \Big|_{\omega=2\pi n / NT_c} \\
 &= F \left\{ h_{tot}(t) \sum_l \delta(t - [lL - i'] T_c) \right\} \Big|_{\omega=2\pi n / NT_c} \\
 &= \frac{1}{2\pi} \mathcal{G}_{tot}(\omega) \otimes \left[\frac{2\pi}{LT_c} \sum_l \delta(\omega - \frac{2\pi l}{LT_c}) e^{j2\pi l i' / L} \right] \Big|_{\omega=2\pi n / NT_c} \\
 &= \frac{1}{LT_c} \sum_l \mathcal{G}_{tot}(\frac{2\pi n}{NT_c} - \frac{2\pi l}{LT_c}) e^{j2\pi l i' / L}
 \end{aligned}$$

we have

$$\begin{aligned}
 q_n &= N_1 \sum_{m=0}^{L-1} x_{mN_1+n} \sum_{i'=0}^{L-1} e^{j2\pi i' m / L} \sum_{l=-\infty}^{\infty} h_{tot}[lL - i'] e^{-j2\pi n (lL - i') / N} \\
 &= N_1 \sum_{m=0}^{L-1} x_{mN_1+n} \sum_{i'=0}^{L-1} e^{j2\pi i' m / L} \frac{1}{LT_c} \sum_l \mathbf{H}_{tot}(\frac{2\pi n}{NT_c} - \frac{2\pi l}{LT_c}) e^{j2\pi l i' / L} \\
 &= \frac{N_1}{LT_c} \sum_{m=0}^{L-1} x_{mN_1+n} \sum_l \mathbf{H}_{tot}(\frac{2\pi n}{NT_c} - \frac{2\pi l}{LT_c}) \sum_{i'=0}^{L-1} e^{j2\pi (l+m) i' / L} \\
 &= \frac{N_1}{T_c} \sum_{m=0}^{L-1} x_{mN_1+n} \mathbf{H}_{tot}(\frac{2\pi n}{NT_c} + \frac{2\pi m}{LT_c}) \\
 &= \frac{N_1}{T_c} \sum_{m=0}^{L-1} x_{mN_1+n} \mathbf{H}_{tot}(\frac{2\pi}{NT_c} [mN_1 + n]), \quad n = 0, \dots, N_1 - 1 \\
 &= N_1 \sum_{m=0}^{L-1} x_{mN_1+n} \mathbf{H}_{tot}[mN_1 + n], \quad n = 0, \dots, N_1 - 1
 \end{aligned}$$

where

$$\mathbf{H}_{tot}[n] = \frac{1}{T_c} \mathbf{H}_{tot}(\frac{2\pi}{NT_c} n), \text{ for } 0 \leq n < N$$

EP 0 889 615 A2

Relationship between q_n and x_n

As shown in Fig. 1G if $H_{tot}[n]$ is a bandpass filter and nonzero only in the intervals $[k(N/2L), (k+1)(N/2L)]$ and $[(2L-k-1)(N/2L), (2L-k)(N/2L)]$, where $0 \leq k < L$, the possible values of m that

5

$$H_{tot}[m(N/L) + n]$$

10 is nonzero for $0 \leq n < (N/L)$ are as follows.

Even k

If k is even, we can have $m=k/2$ and $0 \leq n < (N/2L)$ so that

15

$$H_{tot}[m(N/L) + n]$$

20

is nonzero over the interval $[k(N/2L), (k+1)(N/2L)]$, and $m=(L-1)-k/2$ and $(N/2L) \leq n < (N/L)$ so that

$$H_{tot}[m(N/L) + n]$$

25

is nonzero over the interval $[(2L-k-1)(N/2L), (2L-k)(N/2L)]$.

Odd k

30

If k is odd, we can have $m=(k-1)/2$ and $(N/2L) \leq n < (N/L)$ so that

$$H_{tot}[m(N/L) + n]$$

35

is nonzero over the interval $[k(N/2L), (k+1)(N/2L)]$, and $m=L-(k-1)/2$ and $0 \leq n < (N/2L)$ so that

$$H_{tot}[m(N/L) + n]$$

40

is nonzero over the interval $[(2L-k-1)(N/2L), (2L-k)(N/2L)]$.

The above discussion is illustrated in Fig. 1G for $L = 3$.

45

In another variation that can be used in the present invention, similar advantages to those obtained by limiting bandwidth in the received signal in the downstream transceiver can be obtained by also optionally limiting the upstream data rate of the transceiver as well. In other words, the ADSL standard provides for 31 channels in the upstream direction, but many applications do not require this amount of bandwidth. The constraints, requirements and costs associated with the DMT modulation signal processing, and DAC 330 also can be significantly reduced by transmitting only a sub-set of the available 31 sub-channels. The determination of the appropriate sub-channels would be accomplished in essentially the same manner as set forth above, except that the information on upstream sub-channel SNR usually must be determined by the upstream transceiver, and then fed back to the downstream transceiver. To save time and overhead complexity, and given the fact that there is less variation in bit capacity in sub-channels in this frequency band, one approach also would be to simply select a fixed sub-set of such sub-channels-without regard to their actual performance characteristics. In a software modem environment, Control/Application software 500 would provide a user with selectable control to effectuate a restricted upstream transmission on limited sub-channels. Again, with respect to the ADSL standard, the only requirement in this respect is that the upstream pilot tone must also be transmitted to establish a valid data link. An optional limited "upstream" transmission can be effectuated in a variety of ways by the circuitry already described above in connection with Figs. 2 and 3. The exact details of such implementation will be appar-

55

ent to those of skill in the art given the present teachings.

Although the present invention has been described in terms of a preferred ADSL embodiment, it will be apparent to those skilled in the art that many alterations and modifications may be made to such embodiments without departing from the teachings of the present invention. For example, it is apparent that the present invention would be beneficial used in any xDSL or high speed multi-carrier application environment. Other types of VLSI and ULSI components beyond those illustrated in the foregoing detailed description can be used suitably with the present invention. Accordingly, it is intended that the all such alterations and modifications be included within the scope and spirit of the invention as defined by the following claims.

10 **Claims**

1. A high speed communications system capable of supporting a downstream data transmission from a upstream transceiver using an analog signal consisting of M data carrying signals contained within a bandwidth F, said system comprising:
 - 15 a channel interface circuit for coupling to and receiving said analog signal; and
 - a front end receiving circuit for processing the analog signal and converting it to a digital signal;
 - a processing circuit for extracting N data carrying signals ($N < M$) from the digital signal using a first frequency portion f_1 of the digital signal ($f_1 < F$).
- 20 2. The system of claim 1, wherein the N data carrying signals are selected by the processing circuit based so as to minimize the amount of processing required to extract the selected data from the digital signal.
3. The system of claim 2, wherein the N data carrying signals can be selected during a initialization process setting up a data link to the upstream transceiver.
- 25 4. The system of claim 3, wherein M data carrying signals can be sent by the upstream transmitter during a initialization process, and thereafter, only N data carrying signals are sent.
- 30 5. The system of claim 1, wherein the front end circuit includes: (i) a sub-band filter for passing the first frequency bandwidth portion f_1 of said bandwidth F; (ii) and an analog to digital converter.
6. The system of claim 1, wherein the selected data further includes data obtained from an additional second frequency bandwidth portion f_2 of said bandwidth F, so that an additional number of data carrying signals P from the M data carrying signals ($N+P < M$) can be processed.
- 35 7. The system of claim 6, further including one or more sub-band filters for passing the first frequency bandwidth portion f_1 and second frequency bandwidth portion f_2 of said bandwidth F and an analog to digital converter.
- 40 8. The system of claim 7, wherein a target data rate of the system can be increased by processing an additional number of data carrying signals P from the M data carrying signals, where $N+P < M$.
9. The system of claim 1, wherein the selected data to be extracted from the bandpassed data can be controlled by a user of such system.
- 45 10. The system of claim 9, wherein a user of such system can increase a target data rate of the system by modularly augmenting the front end circuit to include additional bandwidth and analog to digital conversion capacity such that an additional number of data carrying signals P from the M data carrying signals ($N+P < M$) can be processed.
- 50 11. The system of claim 1, further including a front end transmitting circuit for transmitting control information to cause said upstream transceiver to transmit downstream data only using the N data carrying signals.
12. The system of claim 11, wherein the control information transmitted to the upstream transceiver includes feedback information indicating that only N of the M data carrying signals are desirable for downstream data transmission, even during times when said channel is capable of supporting more than N data carrying signals.
- 55 13. The system of claim 12, wherein the control information transmitted to the upstream transceiver further includes feedback information indicating that: (i) the system can support any data protocols used by said upstream trans-

ceiver; and (ii) that they are connected through a channel with substantial signal attenuation characteristics for data signals other than the N data carrying signals.

- 5
14. The system of claim 1, further including a front end transmitting circuit for transmitting an upstream data signal using a second frequency bandwidth F2 different from F, and L data carrying signals, and where $L < M$.
15. A high speed communications system for processing an analog data signal from a channel capable of supporting M modulated sub-channels, said system comprising:
- 10
- a channel interface circuit for coupling to and receiving said analog data signal from the channel;
 - a analog front end circuit for processing the analog data signal and converting it to a digital signal;
 - a processing circuit for extracting data from the digital signal, the digital signal including data taken from a number N of said sub-channels, where N is intentionally selected to have a value less than M and where N is negotiated with an upstream transceiver during a initialization procedure.
- 15
16. The system of claim 15, where the N sub-channels are initially loaded with bit capacities that are left essentially unchanged unless said channel characteristics vary.
- 20
17. The system of claim 15, wherein the selection of the N sub-channels can be done during the initialization procedure.
18. The system of claim 15, wherein the value of N is based on signal processing capability of the processing circuit.
- 25
19. The system of claim 15, wherein a target data rate of the system can be increased by processing a additional number of sub-channels P from the M sub-channels, and where $N+P < M$.
20. The system of claim 15 further including a front end transmitting circuit for transmitting control information to cause said upstream diver to transmit downstream data only using the N sub-channels.
- 30
21. The system of claim 15, wherein the upstream transceiver uses discrete multi-tone (DMT) modulation for generating the M modulated sub-channels, and the channel supports asymmetric digital subscriber loop (ADSL) transmission standards.
- 35
22. A high speed communications system for processing an analog data signal from a channel capable of supporting M modulated sub-channels, said system comprising:
- a channel interface circuit for coupling to and receiving said analog data signal from the channel;
 - a analog front end circuit for processing the analog data signal and converting it to a digital signal;
 - a bus interface circuit for transmitting the digital signal to a host processing device, and for receiving a transmission control signal from the host processing device to cause said upstream transmitter to transmit using only from a number N of said sub-channels, where N is intentionally selected to have a value less than M, and where N is negotiated with a upstream transceiver during a initialization procedure.
- 40
- 45
23. The system of claim 22, wherein the value of N is based on signal processing capability of the host processing device.
- 50
24. The system of claim 22, wherein a data rate of the system can be increased by processing an additional number of sub-channels P from the M sub-channels, and where $N+P < M$.
- 55
25. The system of claim 22, wherein the upstream transceiver uses discrete multi-tone (DMT) modulation for generating the M modulated sub-channels, and the channel supports asymmetric digital subscriber loop (ADSL) transmission standards.
26. A method of processing a xDSL signal from a digital subscriber loop, said method including the steps of:

negotiating a reduced data rate R' for said signal between a downstream and a upstream transceiver; and

thereafter transmitting said xDSL signal from the upstream transceiver to the downstream transceiver utilizing a number of sub-channels N to effectuate the reduced data rate R', where N is intentionally selected to be less than a maximum number of sub-channels M supported by said digital subscriber loop; wherein the number of sub-channels N is based on signal processing capability available to the downstream transceiver.

5
27. The method of claim 26, wherein the data rate of the system can be increased by processing an additional number of sub-channels P from the M sub-channels, and where $N+P < M$.

10
28. The method of claim 26, wherein the upstream transceiver uses discrete multi-tone (DMT) modulation for generating the M sub-channels.

15
29. The method of claim 26, wherein the reduced data rate R' can be specified by a user operating the downstream transceiver.

20
30. A high speed communications data receiver for communicating through a channel at a data rate X with an upstream transmitter capable of transmitting a data stream at a rate Y ($X < Y$), the receiver comprising:

a channel interface circuit for coupling to and receiving said data stream; and
an analog front end circuit for data sampling the analog signal and converting it to a digital signal; and

25
a processing circuit for extracting selected data from the digital signal, and for generating a transmission control signal for causing said upstream transmitter to transmit at a data rate substantially equal to said data rate X during a data stream transmission; and
wherein data sampling requirements of the analog front end circuit and extracting of the processing circuit are reduced because data sampling and extracting is only performed for a fractional portion of the data stream.

30
31. The system of claim 30, wherein the analog front end circuit further includes one or more sub-band filters for filtering the analog data signal to generate the fractional portion of the data stream that requires data sampling and extracting.

35
32. The system of claim 30, further including a front end transmitting circuit for transmitting the transmission control signal from the processing circuit to cause said upstream transceiver to transmit downstream data only at said data rate X.

40
33. The system of claim 32, wherein the control information transmitted to the upstream transceiver includes feedback information indicating that the maximum downstream data transmission data rate is X, even during times when said channel is capable of supporting more than said data rate X.

34. The system of claim 30, further including a front end transmitting circuit for transmitting an upstream data transmission using a data rate Z, where $Z < Y$.

45
35. The system of claim 30, wherein the ratio of X to Y is approximately .5 or less, and this ratio can be increased through modular additions to the analog front end circuit.

50
36. A high speed communications data receiver for communicating through a channel with an upstream transmitter that is capable of transmitting a data signal with a particular frame rate T and data rate Y, the receiver comprising:

a channel interface circuit for coupling to and receiving said data signal; and
an analog front end circuit for sampling the data signal and converting it to a digital signal; and
a processing circuit that: (i) is configurable for processing the digital signal at a data rate $\leq X$ and using said frame rate T, where X is determined for such processing circuit prior to initialization of a data transmission and $X < Y/2$; (ii) generates a transmission control signal for causing said upstream transmitter to transmit at a data rate no greater than X during a data transmission;
55
wherein signal processing requirements for the processing circuit are reduced because processing is only performed at a fractional rate of the available data rate of said transmission protocol.

EP 0 889 615 A2

37. The system of claim 36, wherein the control information transmitted to the upstream transceiver includes feedback information indicating that the maximum downstream data transmission data rate is X, even during times when said channel is capable of supporting more than said data rate X.
- 5 38. The system of claim 36, wherein the feedback information including the data rate X can be controlled by a user of such system.
39. The system of claim 36, wherein the ratio of X to Y is approximately .2 or less.
- 10 40. A high speed communications system for transmitting digital information in a channel capable of supporting a transmission bandwidth F, said system comprising:
- an upstream data transceiver capable of modulating the digital information to generate an analog data signal data transmission using said transmission bandwidth F; and
- 15 a downstream data transceiver channel interface circuit for coupling to and receiving said analog data signal from the upstream data transceiver through said channel, the downstream data transceiver including:
- (i) a front end receiving circuit for processing the analog data signal and converting it to a digital signal; and
- 20 (ii) a processing circuit for demodulating the digital signal, the digital signal including data from a first frequency bandwidth portion f1 of said bandwidth and for generating feedback information indicating to the upstream transceiver that the bandwidth other than f1 is unsuitable for data transmission; and
- (iii) a front end transmitting circuit for transmitting the feedback information using a second frequency bandwidth portion f2 to cause said upstream transceiver to transmit downstream data only using the first frequency portion f1.
- 25 41. The system of claim 40, wherein the ratio of f1 to F is approximately .5 or less, and this ratio can be increased through modular additions to the front end receiving circuit.
42. The system of claim 40, wherein the feedback information contains intentionally altered channel characteristic information.
- 30 43. The system of claim 41, wherein the feedback information, including the size and location of first frequency portion f1, can be controlled by a user of such system.
- 35 44. A high speed communications data receiver for communicating through a channel at a controllable data rate X with an upstream transmitter capable of transmitting a data signal at a frame rate T, and a data rate Y, where $X/Y < 1/2$, the receiver comprising:
- a channel interface circuit for coupling to and receiving said analog data signal; and
- 40 an analog front end circuit for data sampling the analog signal and converting it to a digital signal; and
- a processing circuit for determining said rate X based on processing capabilities available for extracting data from the digital signal, and for generating a transmission control signal for causing said upstream transmitter to transmit using said frame rate T, and a data rate substantially equal to said data rate X during a data transmission.
- 45 45. The receiver of claim 44, wherein said rate X is determined during a calibration routine.
46. The receiver of claim 45, wherein said calibration routine is executed by a host data processor to determine the capabilities of such processor.
- 50 47. The receiver of claim 44, wherein said rate X is configurable by a user of such receiver based on performance characteristics of a host processor comprising a portion of the processing circuit.
48. The receiver of claim 44, wherein X/Y is approximately .5 or less.
- 55 49. A method for communicating through a channel with an upstream transmitter that is capable of transmitting a data signal at a frame rate T, and a data rate Y, the method comprising the steps of:

- receiving said data signal; and
 sampling the data signal and converting it to a digital signal; and
 processing the digital signal at a data rate $\leq X$ and using said frame rate T, where X is determined prior to initialization of a data transmission and $X < Y/2$; and
 5 generating a transmission control signal for causing said upstream transmitter to transmit at a data rate no greater than X during a data transmission.
50. The method of claim 49, wherein the control information transmitted to the upstream transceiver includes feedback information indicating that the maximum downstream data transmission data rate is X, even during times when said
 10 channel is capable of supporting more than said data rate X.
51. The method of claim 49, wherein the feedback information including the data rate X can be controlled by a user of such system.
- 15 52. The method of claim 49, wherein said rate X is determined during a calibration routine.
53. The method of claim 49, wherein said rate X is configurable by a user of such receiver based on performance characteristics of a host processor comprising a portion of the processing circuit.
- 20 54. A method of operating a high speed communications system that is coupled through a channel to an upstream transceiver operating at a maximum data rate Y using a bandwidth F, said method comprising:
- (a) receiving an analog initialization signal having a bandwidth F from the upstream transceiver through the
 25 channel; and
 (b) generating a digital signal based on sampling a portion of the analog data transmission signal corresponding to a first frequency bandwidth portion f1, where $f1 < F$; and
 (c) processing the digital signal to extract data from the digital signal such that an effective receiving rate X (where $X < Y$) is achieved by the system;
 (d) generating feedback information pertaining to the channel transmission characteristics indicating to the
 30 upstream transceiver that data rates higher than X should not be used;
 (e) thereafter receiving an analog data signal transmitted by the upstream transceiver to have a bandwidth f1;
 (f) repeating steps (b) and (c).
55. The method of claim 54, further including a step prior to step (a): receiving a control signal from a user of such system for determining the effective receiving rate X.
 35
56. The method of claim 54, further including a step: determining an optimal bandwidth portion f1 so as to minimize the amount of processing required to extract the data from the digital signal at the receiving rate X.
- 40 57. A high speed communications transceiver for communicating with an upstream transceiver transmitting an analog data transmission signal using M data carrying signals within a bandwidth F through a channel to said system, said transceiver comprising:
- a channel interface circuit for coupling to and receiving said analog data signal from the channel; and
 45 a front end receiving circuit for sampling the analog data signal and generating a digital signal based on such analog data signal, the digital signal including data from a first frequency bandwidth portion f1 of said bandwidth F containing N data carrying signals, where $N < M$; and
 a bus interface circuit for transmitting the digital signal to a host processing device; and
 wherein the system's performance, including data rate, can be scaled based on modifications to said front end
 50 receiving circuit or said host processing device so that a the sampling of the analog data signal can be increased, and the first frequency bandwidth portion f1 can also be expanded.
58. The system of claim 57, wherein the front end receiving circuit includes a filter for passing the first frequency bandwidth portion f1 of said bandwidth F; (ii) and an analog to digital converter.
 55
59. The system of claim 58, wherein when the modifications include additional bandpass filters for increasing the first frequency bandwidth portion from f1 to f2, where $F > f2 > f1$, the number of data carrying signals is increased from N to N+P, where $P = f2/f1 * N$, and $N+P < M$.

EP 0 889 615 A2

60. The system of claim 57, wherein the modifications include adding an additional number of front end circuits k in the system each with a bandpass frequency f_1 to result in $N \cdot k$ data carrying signals being included within the digital signal.
- 5 61. The system of claim 57, wherein the first frequency bandwidth portion f_1 is programmable.
62. The system of claim 57, further including a front end transmitting circuit for transmitting control information to cause said upstream transceiver to transmit downstream data only using the N data carrying signals.
- 10 63. The system of claim 62, wherein the control information transmitted to the upstream transceiver includes feedback information from the host processing device indicating to the upstream transceiver that only N of the M data carrying signals are desirable for downstream data transmission, even if said channel is capable of supporting more than N data carrying signals.
- 15 64. The system of claim 63, wherein the front end transmitting circuit transmits an upstream data transmission using a second frequency bandwidth F_2 and L upstream data carrying signals, and where $L < M$.
65. The system of claim 57, further including a host processor circuit in the host processing device for extracting selected data from the N data carrying signals.
- 20 66. The system of claim 65, wherein host processor circuit includes a host microprocessor, a programmable memory coupled to the microprocessor, and a data extraction routine located in the memory which can be executed by the microprocessor.
- 25 67. The system of claim 66, wherein the modifications include upgrading said host processing circuit to include additional signal processing power for processing an additional number of data carrying signals.
68. A method of operating a high speed interface between an upstream transceiver and a host processing device at a target data rate, said method comprising:
- 30 (a) receiving an analog initialization signal having a bandwidth F from the upstream transceiver through a communications channel; and
(b) generating a digital signal based on sampling a portion of the analog initialization signal corresponding to a first frequency bandpass portion f_1 ;
- 35 (c) transmitting the digital signal to said host processing device so that characteristics of data carrying signals contained within first frequency bandpass portion f_1 can be determined, and a number of such data carrying signals can be configured for use by said host processing device to achieve said target data rate; and
(e) generating feedback information indicating to the upstream transceiver that bandwidth other than the first frequency bandpass f_1 should not be used for data transmission; and
- 40 (f) receiving an analog data transmission signal having a bandwidth f_1 from said upstream transceiver; and
(g) generating a digital signal based on sampling the analog data transmission signal; and
(h) transmitting the digital signal to the host processing device so that it can be processed to extract selected data from the data carrying signals;
- 45 (i) when a data rate increase is required, expanding the first frequency bandpass portion f_1 and returning to step (a).
69. The method of claim 68, further including a step of: determining an optimal size and location of first frequency bandpass portion f_1 so as to minimize the amount of processing required by said host processing device to extract the data from the digital signal.
- 50 70. The method of claim 68, wherein the ratio of f_1 to F is approximately .5 or less, and a data rate of such interface is controlled by controlling this ratio.
71. The method of claim 68 wherein the analog data transmission is comprised of M modulated sub-channels within bandwidth F , and the selected data is contained in N of the M sub-channels within first selected frequency bandpass portion f_1 , where $N < M$.
- 55 72. The method of claim 68, further including a step: determining an optimal set of N sub-channels so as to minimize

EP 0 889 615 A2

the amount of processing required to extract the data from the digital signal.

5 73. The method of claim 68, further including a step wherein protocol information pertaining to standards applicable to Asymmetric Digital Subscriber Loops is transmitted by the upstream data transceiver so as to set up a ADSL compatible data link.

10 74. The method of claim 68, wherein during step (i) the first frequency bandpass portion f_1 is increased by the use of additional bandpass filters for increasing the first frequency bandwidth portion from f_1 to f_2 , where $F > f_2 > f_1$, so that the selected data is received at an increased rate equal to approximately f_2/f_1 .

15

20

25

30

35

40

45

50

55

FIGURE 1

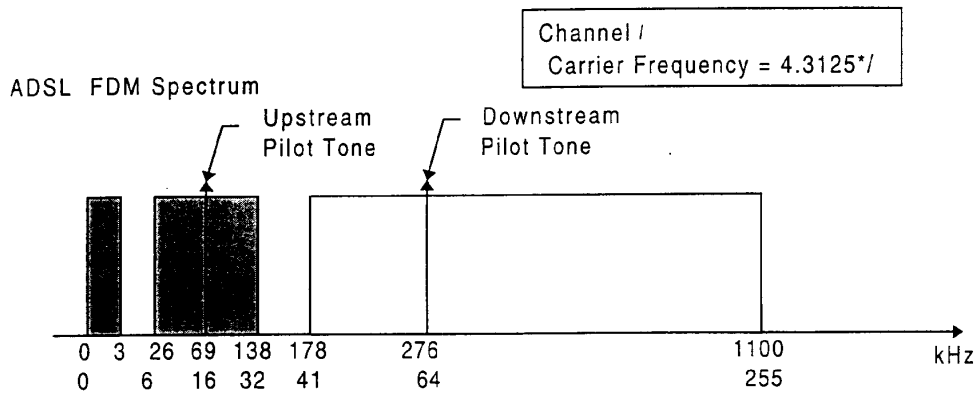

FIGURE 1B

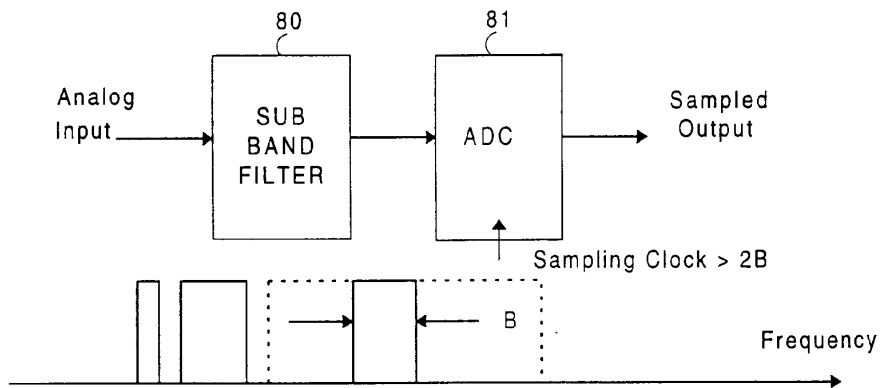

FIGURE 1C

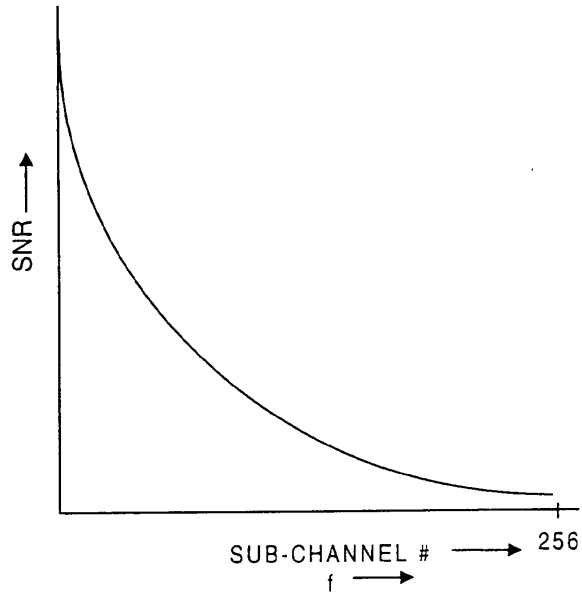

FIGURE 1D

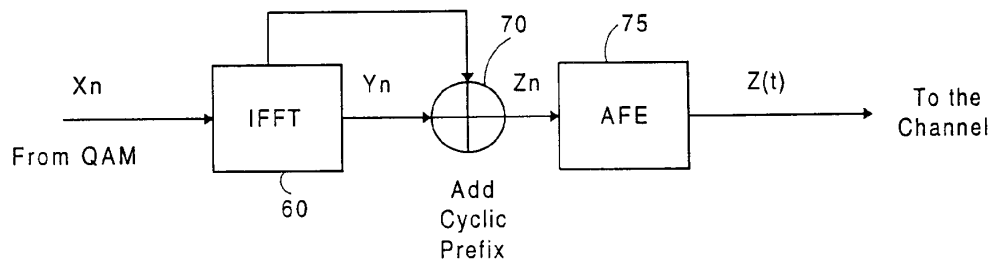

FIGURE 1E

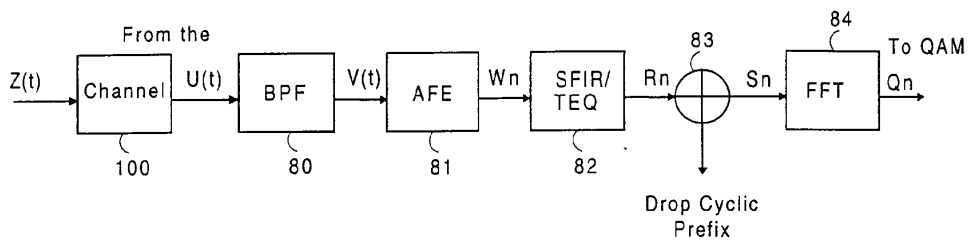

FIGURE 1F

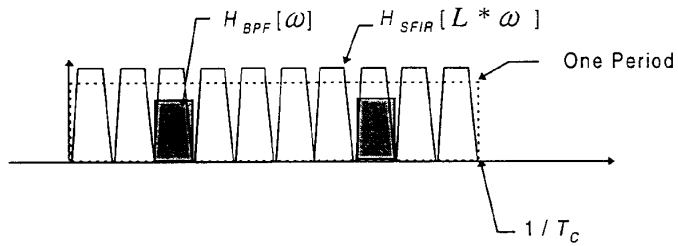

FIGURE 1G

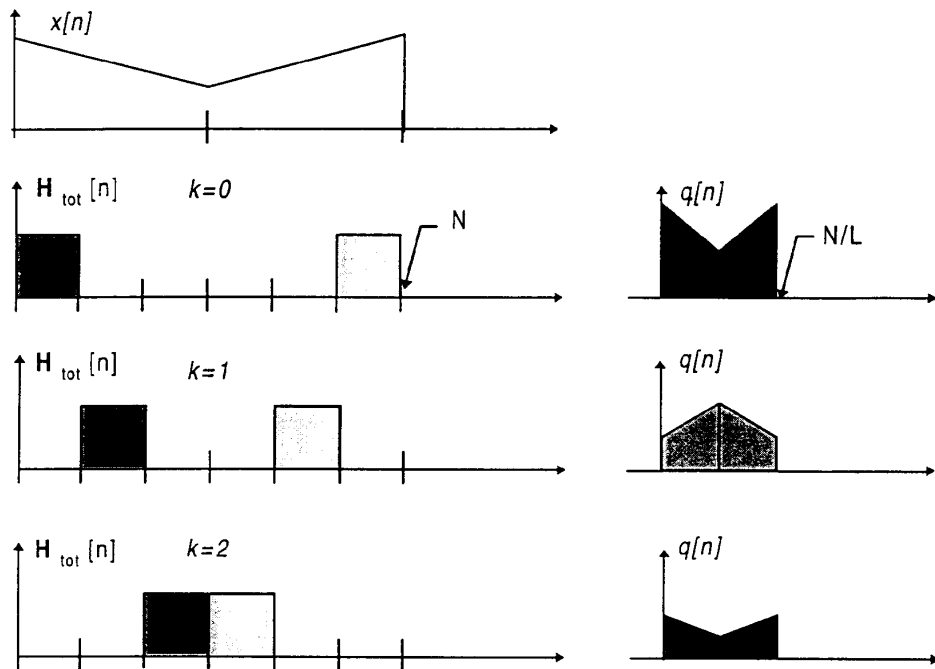

FIGURE 2

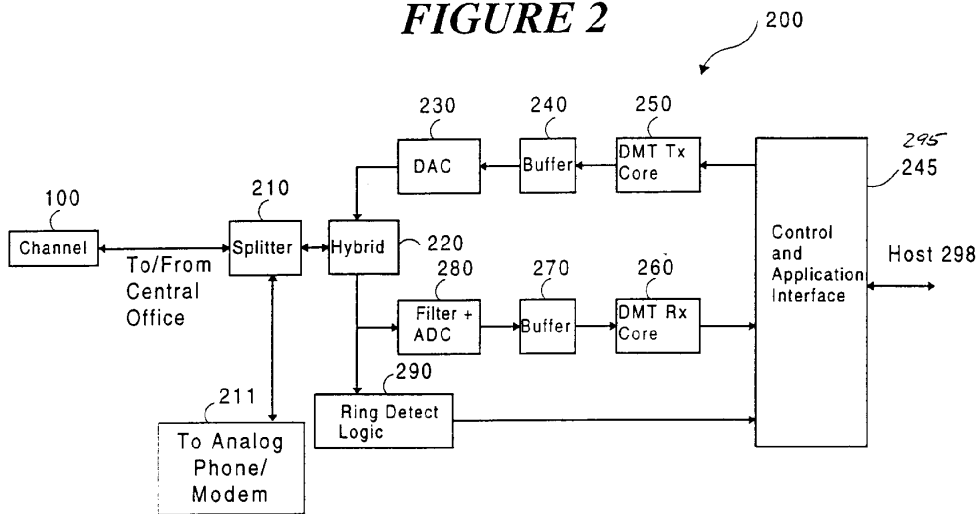

FIGURE 3A

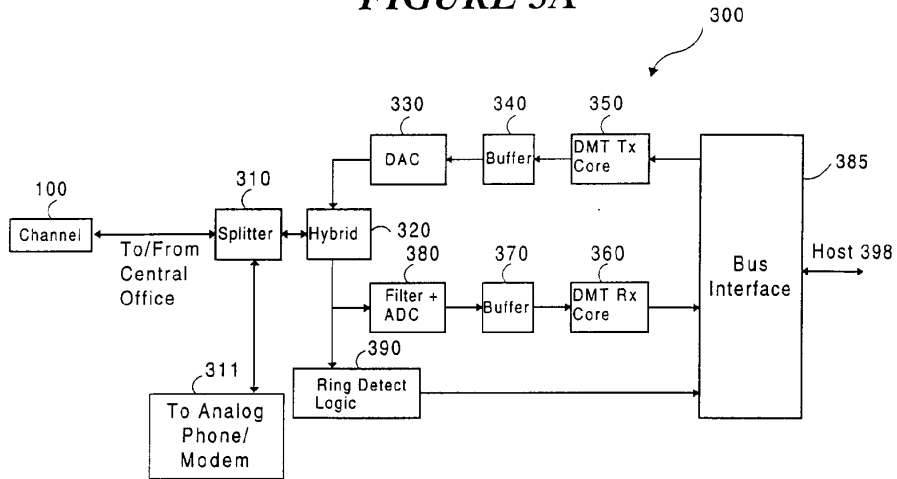

FIGURE 3B

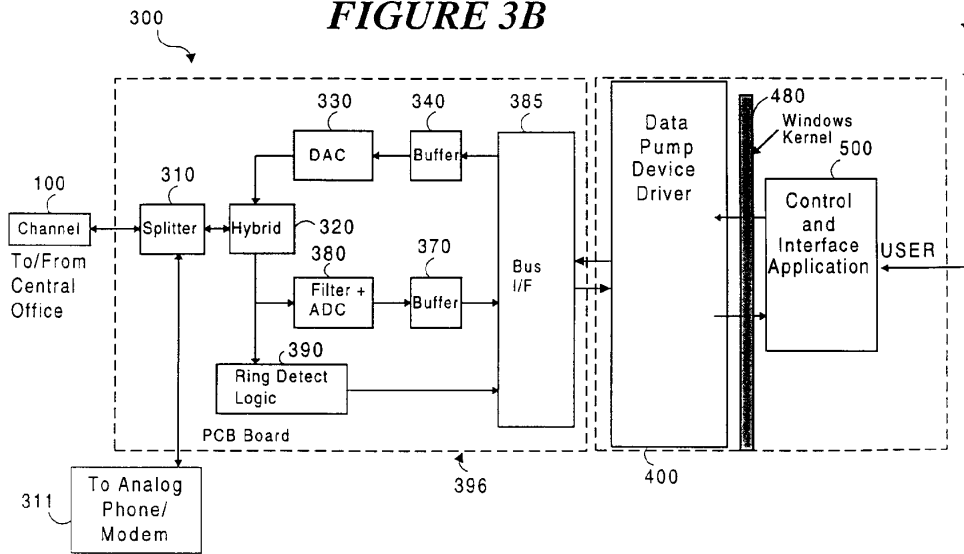

FIGURE 4

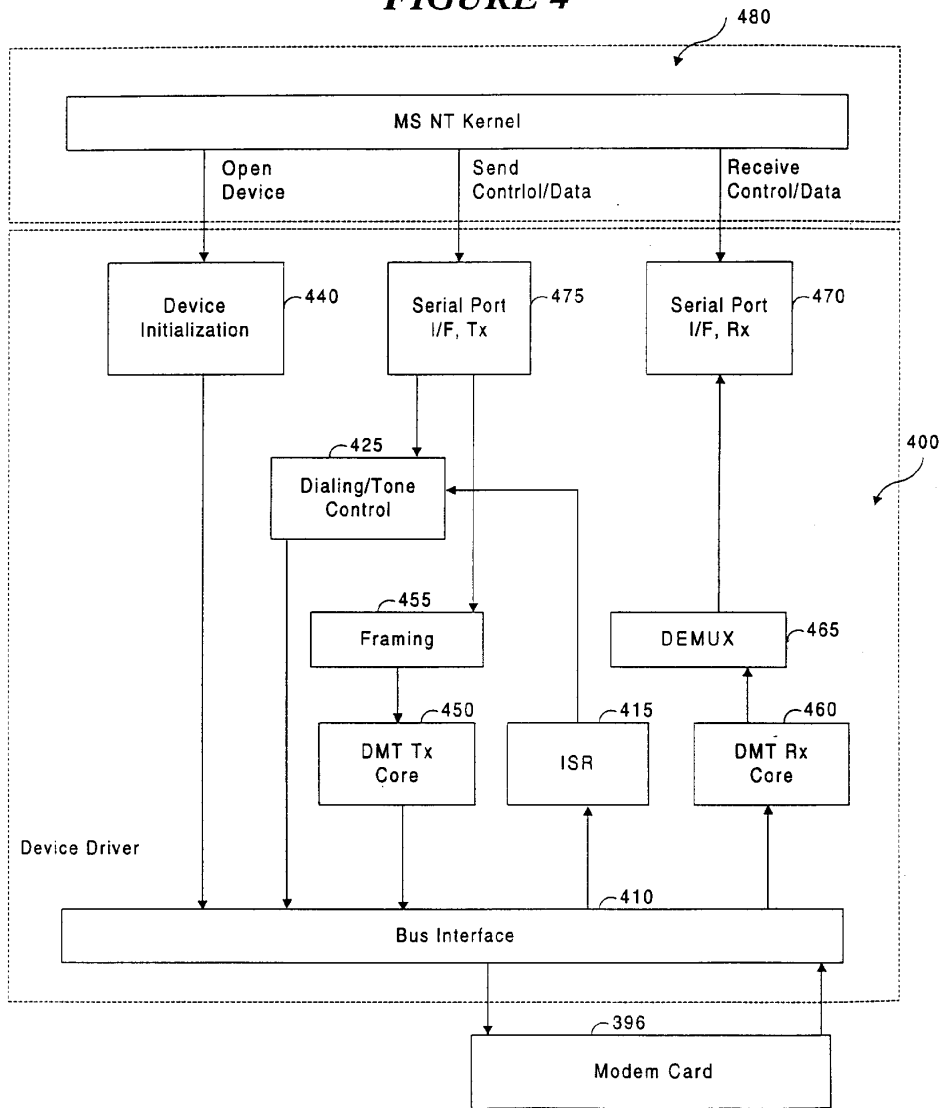

FIGURE 5

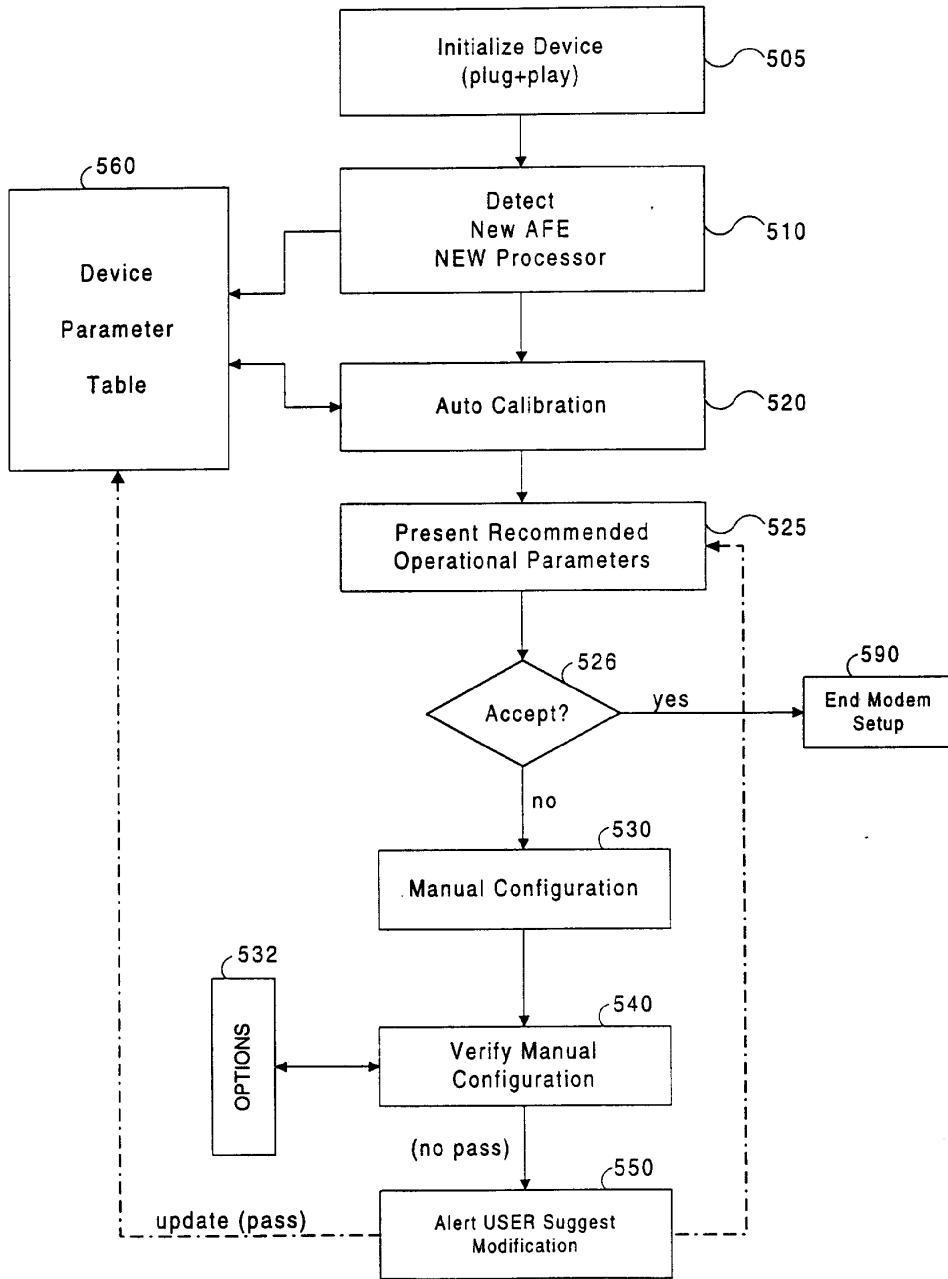
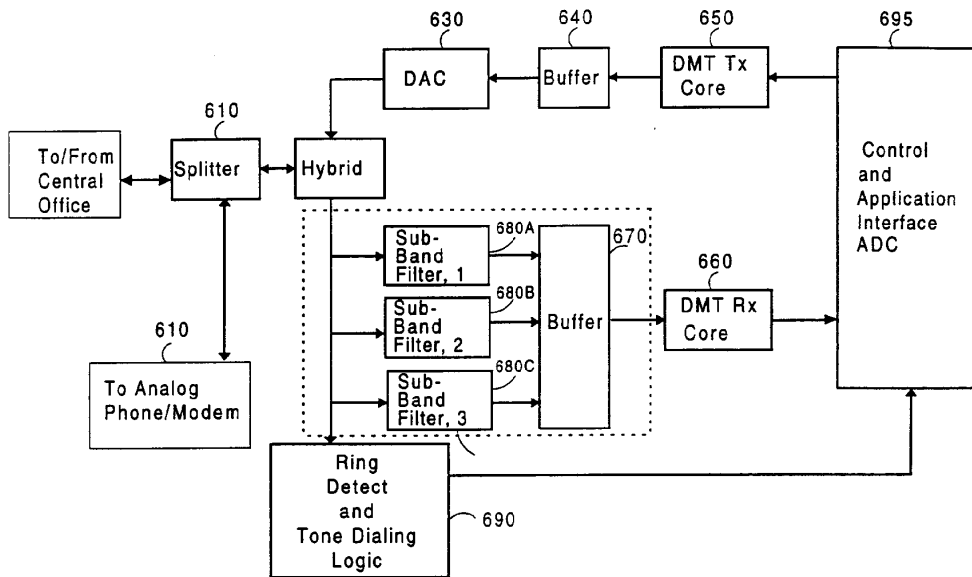

FIGURE 6



(12) **UK Patent Application** (19) **GB** (11) **2 303 032** (13) **A**

(43) Date of A Publication **05.02.1997**

(21) Application No **9613602.3**

(22) Date of Filing **28.06.1996**

(30) Priority Data

(31) **95019065** (32) **30.06.1995** (33) **KR**

(71) Applicant(s)

Samsung Electronics Co Limited

(Incorporated in the Republic of Korea)

**416 Maetan-dong, Paldal-gu, Suwon-City, Kyungki-do,
Republic of Korea**

(72) Inventor(s)

You-sik Chun

(74) Agent and/or Address for Service

**Elkington and Fife
Prospect House, 8 Pembroke Road, SEVENOAKS,
Kent, TN13 1XR, United Kingdom**

(51) INT CL⁶
H04L 5/06

(52) UK CL (Edition O)
H4P PAQ

(56) Documents Cited
None

(58) Field of Search
UK CL (Edition O) **H4P PAL PAQ PEM**
INT CL⁶ **H04L 5/06 27/34**
ONLINE:WPI

(54) **Adaptive bit swapping between channels of a discrete multitone system**

(57) An adaptive bit swapping method and device are provided. The method includes the steps of (a) initializing (200) the DMT system to transmit the data via the channel in a steady state; (b) selecting (204) a frame (400) having an inserted sync block from a frame structure of the transmitted data; (c) calculating (210) the signal-to-noise ratios (SNRs) of respective sub-channels of the selected frame; (d) calculating (214) a first difference value between the present representative SNRs calculated in step (c) and the previous representative SNRs of each sub-channel; (e) selecting (216) a maximum value and minimum value among the first difference values of the respective sub-channels; (f) obtaining a second difference value being a difference between the maximum value and the minimum value; (g) determining (218) whether the second difference value is equal to or greater than the predetermined threshold value; and (h) correcting (220) bit and power assigning tables of a transmitter and a receiver if the second difference value is greater than or equal to the threshold value. In addition, the bit and power assigning tables can be corrected accurately since bits and power are swapped using an actually measured SNR.

FIG. 3

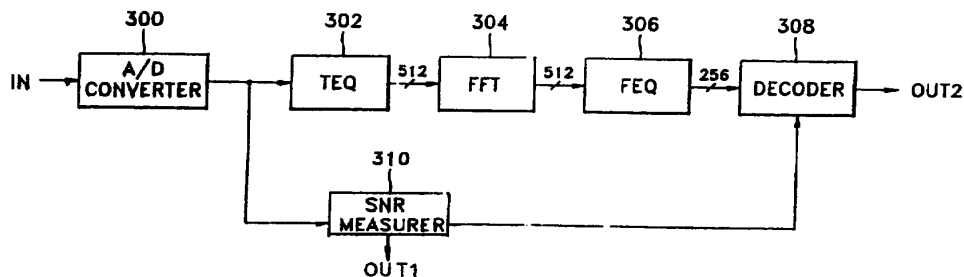

GB 2 303 032 A

FIG. 1 (PRIOR ART)

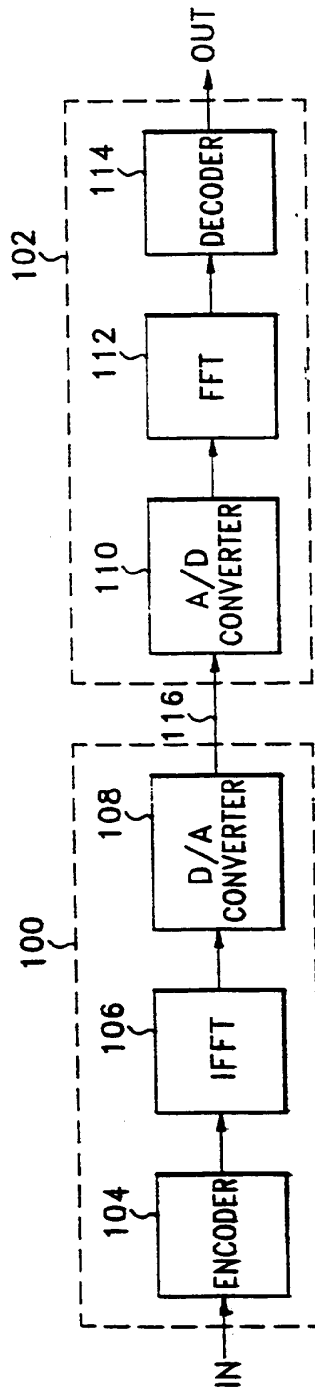

FIG. 2

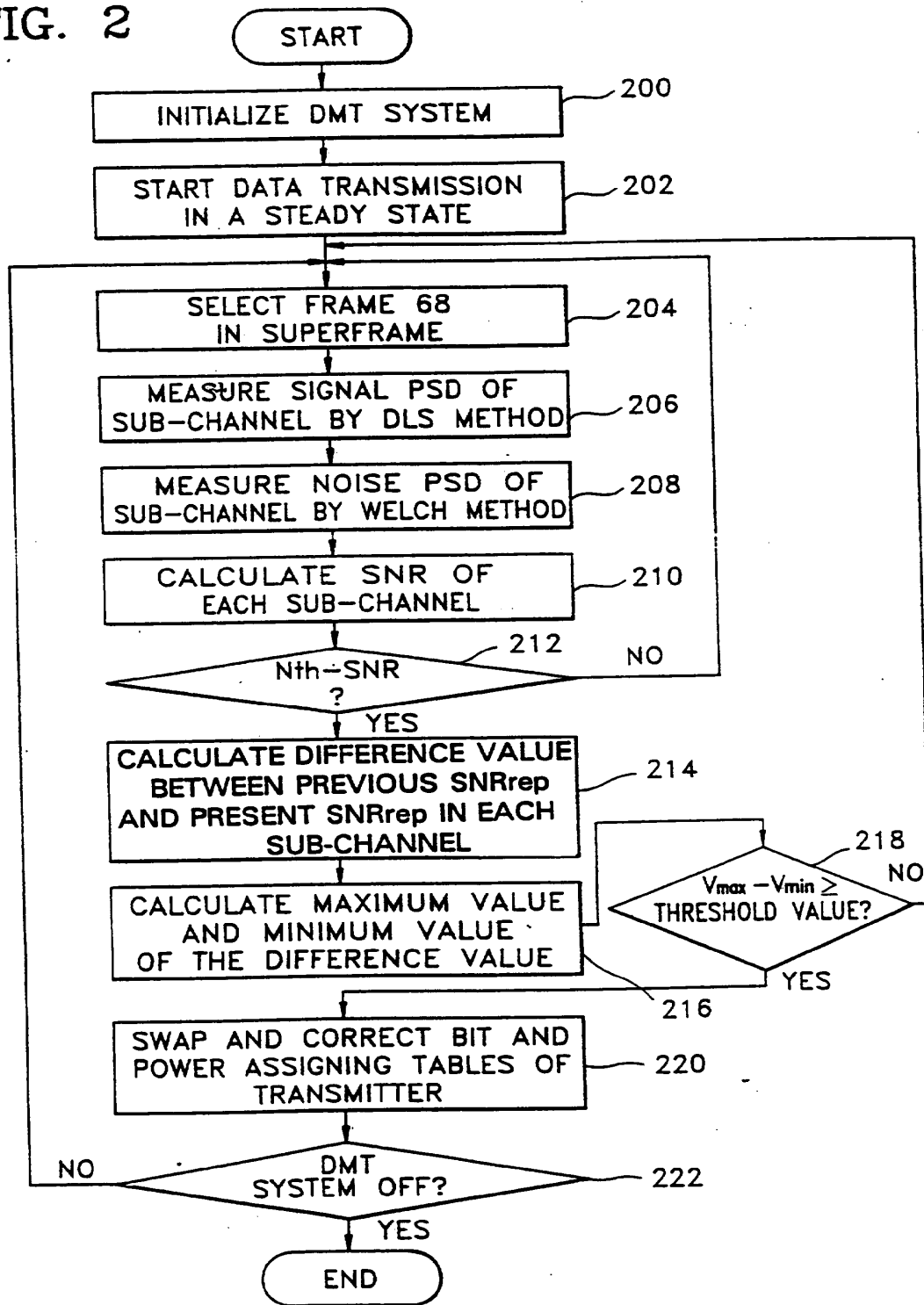

FIG. 3

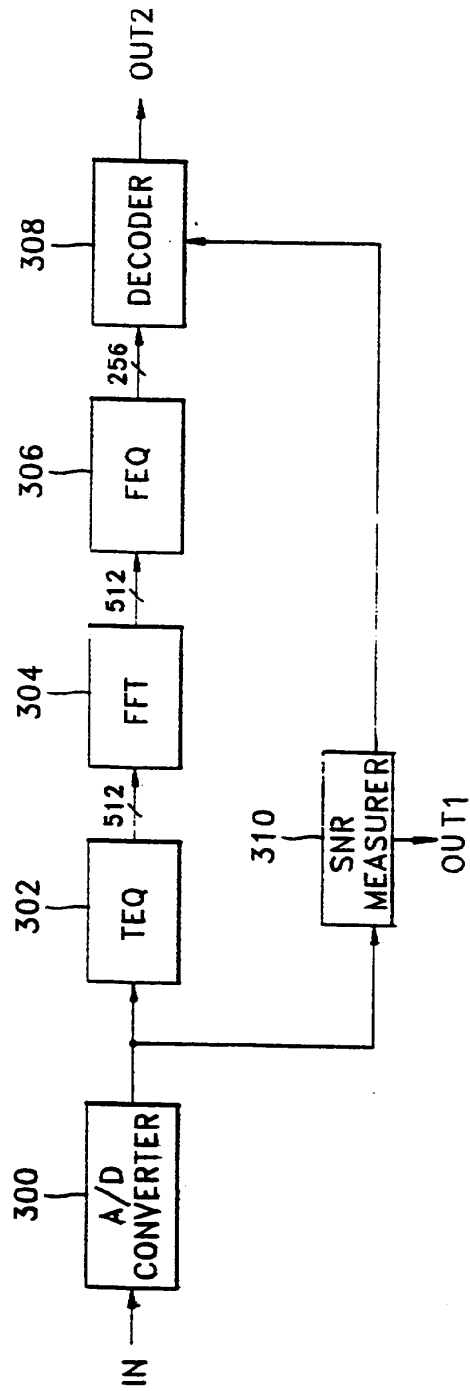
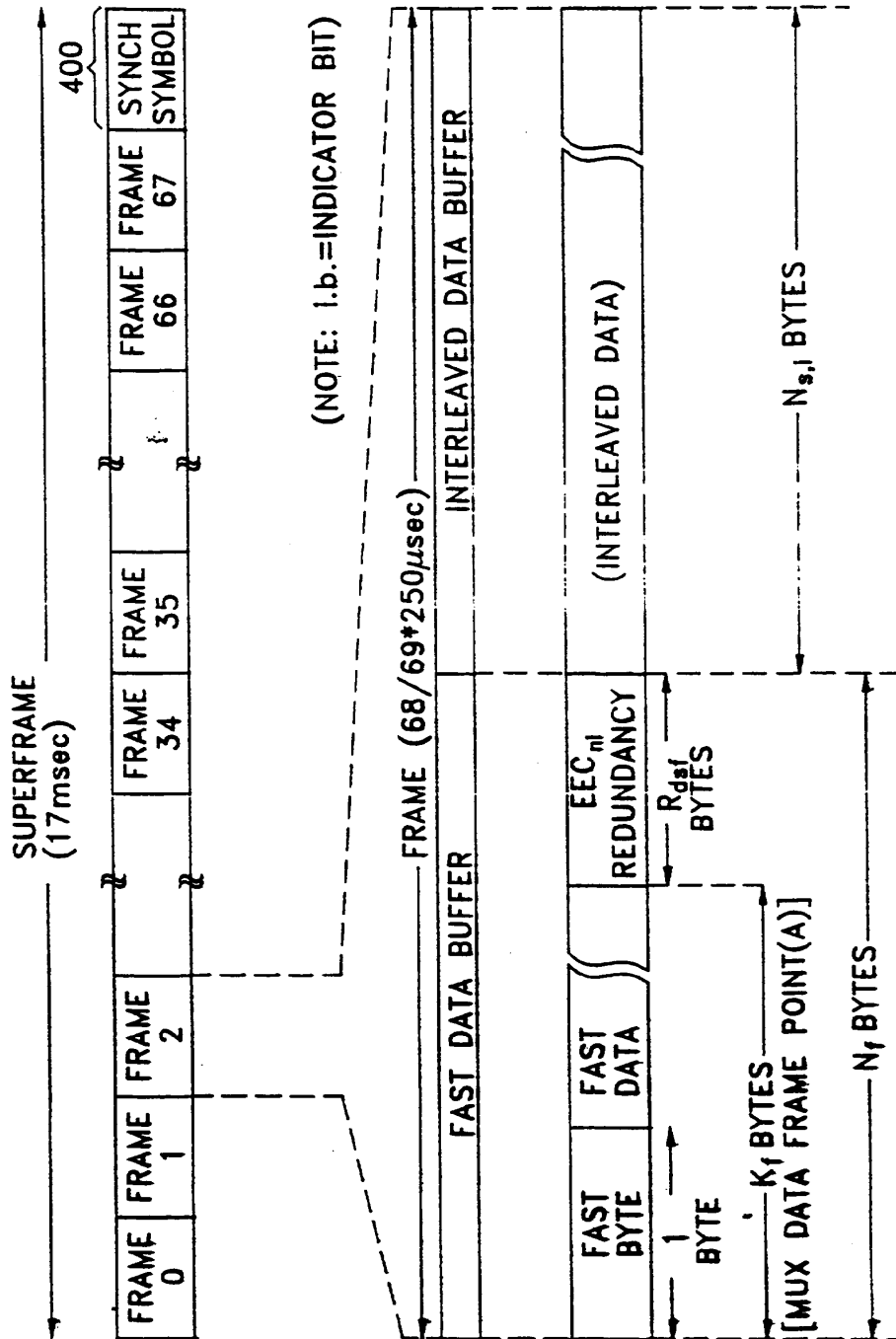

FIG. 4



**ADAPTIVE BIT SWAPPING METHOD AND DEVICE
FOR DISCRETE MULTITONE SYSTEM**

5 The present invention relates to a discrete multitone (DMT) system, and more particularly, to an adaptive bit swapping method and device for a DMT system, which adjust the number of bits and power assigned to each sub-channel according to channel characteristics varied during data transmission.

10 A multicarrier is generally used in a DMT system to use a channel efficiently for transmitting data. Basically in multicarrier modulation, several carrier-modulated waveforms are overlapped to represent an input bit stream. A multicarrier transmission signal is the composite of M independent sub-signals or sub-channels, each having the
15 same bandwidth of 4.3125KHz and respective main frequencies of f_i ($i=1, 2, 3, \dots, M$). These sub-signals are Quadrature Amplitude Modulation (QAM) signals. When data is transmitted at a high speed via an inferior transmission path such as a copper line, the DMT system enables the data
20 to be transmitted at 6Mbps or above, thus offering a good service. In this DMT system using several carriers, the number of bits and power of each channel depending on its signal-to-noise ratio (SNR) are assigned to each sub-channel in the initialization of the system.

25 Changing the number of bits and power assigned to each sub-channel according to its SNR, which is varied without an interruption in a data stream in a data transmission mode, is referred to as bit swapping. Bit swapping is used

in an Asymmetric Digital Subscriber Line (ADSL) service employing the DMT system to reduce an error probability of transmission data.

5 Channel characteristics vary gradually with time in most systems, and frequency response characteristics of an ADSL loop vary gradually with temperature. Therefore, a channel model determined in the initialization of a system should be changed according to the frequency response characteristics.

10 A conventional method for allocating bits to a sub-channel will be described as follows.

A transmitter terminal as well as a receiver terminal by adaption can operate according to the essential concept of a bit allocating method which has been proposed in a dissertation submitted to the Department of Electrical Engineering and the Committee on Graduate Studies of STANFORD University in partial fulfillment of the requirements for the Degree of Doctor of Philosophy, May 15 1993, entitled "BANDWIDTH OPTIMIZED DIGITAL TRANSMISSION TECHNIQUES FOR SPECTRALLY SHAPED CHANNELS WITH IMPULSE NOISE", by Ronald R. Hunt and P.S. Chow. Details of the bit allocating method there described are as follows:

20 1. the steady state mean square errors (MSE)'s of all used sub-channels are monitored, where these error values are differences between inputs and outputs of a slicer;

25 2. it is determined continuously whether the difference between a maximum error value and a minimum error value is a predetermined threshold value (generally

3dB) or above, and if the difference is the threshold value or above, the procedure goes to the subsequent step;

3. the bit number of a value in a bit allocation table for a sub-channel having the maximum error value is decreased by 1, while the bit number of a value in a bit allocation table for a sub-channel having the minimum error value is increased by 1;

4. the minimum error is doubled, while the maximum error is halved;

5. the slicer settings for two sub-channels whose bit values are changed are adjusted; and

6. the bit swapping information is sent back to a transmission part.

The initial number of bits allocated to a sub-channel is determined according to an SNR measured during an initialization in an ADSL DMT system. However, the above bit allocation method exhibits the drawback that an incorrect bit swapping may be performed, since an MSE value may be increased due to an error, such as a burst error when data is examined in a reception part, or a frequency-domain equalizer (FEQ) error which can affect MSE in a steady state.

To circumvent the above problems, it is first object of the present invention to provide an adaptive bit swapping method for a DMT system in which bits allocated to each sub-channel are swapped in a transmission unit according to an actually measured SNR.

It is second object of the present invention to

provide an adaptive bit swapping device for a DMT system.

To achieve the first object, there is provided an adaptive bit swapping method in a discrete multitone (DMT) system for an asymmetric digital subscriber line (ADSL) which has a transmitter for encoding and converting data to be transmitted via a channel, and a receiver for restoring the transmitted data to the original form by conversion and decoding, said method comprising the steps of: (a) initializing said DMT system to transmit said data via said channel in a steady state; (b) selecting a frame having an inserted sync block from a frame structure of said transmitted data; (c) calculating the signal-to-noise ratios (SNRs) of respective sub-channels of said selected frame; (d) calculating first difference value between the present representative SNRs calculated in step (c) and the previous representative SNRs of each sub-channel; (e) selecting a maximum value and minimum value among the first difference values of said respective sub-channels; (f) obtaining the second difference value between said maximum value and said minimum value; (g) determining whether said second difference value is equal to or greater than the predetermined threshold value; and (h) correcting bit and power assigning tables of a transmitter and a receiver if said second difference value is greater than or equal to said threshold value.

To achieve the second object, there is provided an adaptive bit swapping device functioning as a receiver for restoring the transmitted data to the original form by

conversion and decoding, said device being included in a discrete multitone (DMT) system for an asymmetric digital subscriber line (ADSL) which has a transmitter for encoding and converting data to be transmitted via a channel, said
5 device comprising: A/D converting means for converting said analogue data signal received via said channel into a digital signal; time-domain equalizing means for receiving said digital signal and reducing a guard band used to remove an interblock interference; fast-Fourier
10 transforming means for receiving the output of said time-domain equalizing means and demodulating said data signal modulated in said transmitter; frequency-domain equalizing means for receiving the output of said fast Fourier transforming means and compensating for a phase error of
15 each sub-channel; SNR measuring means for selecting a frame having an inserted sync block from a frame structure of said transmitted data, calculating the signal-to-noise ratios (SNRs) of respective sub-channels of said selected frame, calculating first difference value between the
20 present representative SNRs calculated above and the previous representative SNRs of each sub-channel, selecting a maximum value and minimum value among the first difference values of said respective sub-channels, obtaining the second difference value between said maximum value and said minimum value, determining whether said
25 second difference value is equal to or greater than the predetermined threshold value and outputting to a transmitter and a receiver the signal used for correcting

bit and power assigning tables of a transmitter and a receiver; and decoding means for receiving the outputs of said SNR measuring means and said frequency-domain equalizing means, resetting a slice value, and decoding said reset slice value.

5

Specific embodiments of the present invention are described in detail below, by way of example, with reference to the attached drawings, in which:

FIG. 1 is a block diagram of a conventional basic DMT system;

10

FIG. 2 is a flow-chart of a bit swapping method for a DMT system according to an embodiment of the present invention;

FIG. 3 is a block diagram of a receiving unit in a DMT system for performing the method of FIG. 2 according to an embodiment of the present invention; and

15

FIG. 4 illustrates the structure of a superframe based on "ADSL standards", which is transmitted in a steady state.

An adaptive bit swapping method and device for a DMT system according to an embodiment of the present invention will be described below, with reference to the attached drawings.

20

A conventional basic DMT system shown in FIG. 1 has a transmitter 100 including an encoder 104, an inverse fast Fourier transformer (IFFT) 106 and a digital/analogue (D/A) converter 108, a receiver 102 including an analogue/digital (A/D) converter 110, a fast Fourier transformer (FFT) 112

25

and a decoder 114, and a transmission path (a transmission channel or a channel) 116. A DMT system for an ADSL transmits a signal via 256 individual channels each having a 4KHz bandwidth. The encoder 104 of the transmitter 100 in the DMT system shown in FIG. 1 simply receives data sequences via an input terminal IN (the accurate number of bits depends on a data rate and an overhead) and allocates the input data sequences to a multitude of sub-channels. The IFFT 106 produces a plurality of time based samples having several real number values from an encoded value. The D/A converter 108 converts a plurality of the received time based samples into an analogue signal suitable for transmission via a copper line, and transmits the analogue signal to the A/D converter 110 via the transmission path 116.

The receiver 102 performs the operations of the transmitter 100 in a reverse order. The receiver 102 consists of three components for performing time recovery, filtering, and channel check functions, respectively.

An adaptive bit swapping device for a DMT system according to an embodiment of the present invention is shown in Fig.3 and includes an A/D converter 300, a time-domain equalizer (TEQ) 302, an FFT 304, a frequency-domain equalizer (FEQ) 306, a decoder 308, and an SNR measurer 310.

Referring to FIG. 2, showing an algorithm for a bit swapping method for a DMT system according to an embodiment of the present invention, when the DMT system is activated

to transmit data, it is initialized with regard to the channel conditions of the transmitter and receiver, in step 200. The initialization is divided into activation & recognition, transceiver training, and channel analysis & exchange. The initialization in the embodiment of the present invention is especially concerned with channel analysis, since the SNR of each sub-channel of a channel formed between the transmitter and the receiver is measured and the number of bits and power are assigned according to the variation in the measured SNR. When the DMT system is placed in a steady state after the initialization, data transmission begins, in step 202.

FIG. 4 illustrates the structure of a superframe of data transmitted in a steady state, which is determined by "ADSL standards". Referring to FIG. 4, a sync(ronization) symbol 400 used to restore the synchronization of the data without reinitialization when the data are affected by an instantaneous interrupt is inserted in a frame 68 of frames 0-68.

In step 204, frame 68 alone is selected after step 202 in the embodiment of the present invention, whereas all frames among the 68 frames shown in FIG. 4 are selected to obtain MSEs in the prior art. In step 206, the signal PSD of each sub-channel is measured by a deterministic least sequence (DLS) method, after step 204. The DLS method indicates that known sequence values received from the transmitter via the channel are accumulated and averaged. A channel response free of random noise can be achieved by

this method, and the signal PSD of each sub-channel can be achieved by fast Fourier transforming the channel response. In step 208, the noise PSD of each sub-channel is measured by a Welch method after step 206. After step 208, the SNR of each sub-channel is obtained from the measured signal PSD and noise PSD in step 210. After step 210, it is determined whether the obtained SNR is the Nth SNR of each sub-channel or not in step 212. Here, N is a predetermined number(50~150). Steps 206-210 should be performed repeatedly for series of N sequent superframes because a plurality of sync frames 68, each pattern of which is known, is needed in order to accurately measure the SNR of each sub-channel.

If N SNRs for each sub-channel are obtained, then firstly, the representative SNR(SNR_{rep}) of each sub-channel is obtained by averaging the N SNRs. Then, the difference value(or first difference value) between the presently obtained SNR_{rep} and the previously obtained SNR_{rep} is calculated for each sub-channel. By a method similar to that described above, all first difference values for all sub-channels are obtained in step 214.

The maximum and the minimum values among the first difference values calculated in step 214 are selected in step 216. After step 216, the second difference value between the maximum value and the minimum value is calculated and it is determined whether the second difference value is a predetermined threshold value(around 3 DB) or not in step 218. If the second difference value is

smaller than the threshold value, the procedure feeds back to step 204, and if it is equal to or greater than the threshold value, the bits and power assigned to a corresponding sub-channel in a transmitter are swapped. That is, the number of bit of a sub-channel having a minimum value is assigned to sub-channel having a maximum value. Thus, the corresponding parameters (a bit number and power table) should be changed to enable a receiver to make an accurate decision, in step 220. In step 222, it is determined whether the DMT system is off after step 220. If it is not off, the procedure feeds back to step 204, and if it is off, the bit swapping method of the present invention ends.

Since the bit swapping only takes place once after at least one superframe has been transmitted (17msec is required for one superframe transmission), a long time is required for the bit swapping. However, even though the channel changes during the time required for the bit swapping, this method can be used because a channel changes very slowly, for example by temperature, etc.

Fig.3 shows a device for performing the above-described method. The A/D converter 300 converts an analogue signal received via an input port IN into a digital signal. The TEQ 302 receives the digital signal from the A/D converter 300 and reduces a guard band used to remove an interblock interference (IBI) produced due to characteristics of a DMT system. For this purpose, a finite impulse response filter (FIR) may be used as the TEQ

302. The FFT 304 receives the signal output from the TEQ 302 and performs a demodulation corresponding to a modulation of the transmitter. Thus, the FFT 304 serves as a demodulator corresponding to the IFFT 106 of FIG. 1. The
5 FEQ 306 is a filter for receiving the output of the FFT 304 and compensating for a phase error of each sub-channel. Meanwhile, the SNR measurer 310 of FIG. 3 receives the output of the A/D converter 300 and performs the steps 204-220 described in Fig.2. The SNR measurer 310 can be
10 achieved in terms of software in a digital signal processor. After processing step 218 shown in Fig.2, the SNR measurer 310 outputs the control signal for bit swapping to the transmitter via an output port OUT1 to correct a bit allocation table at a transmitter, and the measured SNR of each sub-channel is output to the decoder
15 308. The decoder 308 receives the outputs of the SNR measurer 310 when frame 68 is input, and the output of the FEQ 306 when any frame among frames 0 - 67 is input, decides a slicer value, decodes the reset slicer value, and
20 outputs the decoded value via an output port OUT2.

As described above, in the adaptive bit swapping method and device of embodiments of the present invention in the DMT system, the method for comparing SNRs is added to an SNR measuring method used in a conventional process
25 of initialization. The adaptive bit swapping device selects only frame 68 from each superframe, thereby simplifying a conventional complex hardware construction using all frames. Furthermore, in the adaptive bit swapping

5 method, more accurate swapping information for changing the number of bit and corresponding power can be transmitted to a transmitter than in the conventional method depending on an MSE, since an actually measured SNR value on a frame 68 is used when the assigned bit number and the assigned quantity of power are changed according to a channel variation.

CLAIMS

1. An adaptive bit swapping method for use in a discrete multitone (DMT) system for an asymmetric digital subscriber line (ADSL) which has a transmitter for encoding and converting data to be transmitted via a channel, and a receiver for restoring the transmitted data to the original form by conversion and decoding, said method comprising the steps of:

(a) initializing said DMT system to transmit said data via said channel in a steady state;

(b) selecting a frame having an inserted sync block from a frame structure of said transmitted data;

(c) calculating the signal-to-noise ratios (SNRs) of respective sub-channels of said selected frame;

(d) calculating first difference values between the present representative SNRs calculated in step (c) and the previous representative SNRs of each sub-channel;

(e) selecting a maximum value and minimum value among the first difference values of said respective sub-channels;

(f) obtaining a second difference value being a difference between said maximum value and said minimum value;

(g) determining whether said second difference value is equal to or greater than a predetermined threshold value; and

(h) correcting bit and power assigning tables of a transmitter and a receiver if said second difference value

is greater than or equal to said threshold value.

2. An adaptive bit swapping method as claimed in claim 1, wherein said step (a) comprises the steps of:

5 establishing the initial bits and power values of said DMT system; and

starting a transmission of data in a steady state of said DMT system.

3. An adaptive bit swapping method as claimed in claim 1 or claim 2, wherein said step (c) comprises the steps of;

10 measuring the signal power spectrum density (PSD) of each sub-channel by a deterministic least sequence (DLS) method;

15 measuring a noise PSD of each sub-channel by a Welch method; and

calculating said SNR of each sub-channel from said measured signal PSD and said noise PSD.

4. An adaptive bit swapping method as claimed in any of claims 1 to 3, wherein said steps (b) and (c) are performed repeatedly a predetermined number of times, and representative SNR value of each sub-channel are calculated making use of said SNRs if the predetermined number of SNRs is obtained for each sub-channel.

5. An adaptive bit swapping method as claimed in claim 4, wherein said step (c) comprises the step of;

25 feeding the procedure back to said step (b), if said predetermined number of SNRs of each sub-channel has not been obtained .

6. An adaptive bit swapping method as claimed in any preceding claim, wherein said step (g) comprises the step of;

5 feeding the procedure back to said step (b), if said second difference value is not greater than or equal to said predetermined threshold value.

7. An adaptive bit swapping device adapted to function as a receiver for restoring transmitted data to its original form by conversion and decoding, said device being adapted for inclusion in a discrete multitone (DMT) system for an asymmetric digital subscriber line (ADSL) which has a transmitter for encoding and converting data to be transmitted via a channel, said device comprising:

15 A/D converting means for converting said analogue data signal received via said channel into a digital signal;

time-domain equalizing means for receiving said digital signal and reducing a guard band used to remove an interblock interference;

20 fast-Fourier transforming means for receiving the output of said time-domain equalizing means and demodulating said data signal modulated in said transmitter;

25 frequency-domain equalizing means for receiving the output of said fast Fourier transforming means and compensating for a phase error of each sub-channel;

SNR measuring means for obtaining the representative SNRs of said respective sub-channels from the output of said A/D converting means using a frame having an inserted

sync symbol from a frame structure of transmitted data,
calculating a first difference values between the previous
representative SNR and present representative SNR for each
sub-channel, comparing a threshold value with a second
5 difference value being a difference between maximum and
minimum value of said first difference values, and
outputting to a transmitter and a receiver the signal used
for correcting a bit allocation table according to the
compared result; and

10 decoding means for receiving the outputs of said SNR
measuring means and said frequency-domain equalizing means,
resetting a slice value, and decoding said reset slice
value.

8. An adaptive bit swapping device adapted to
15 function as a receiver for restoring transmitted data to
its original form by conversion and decoding, said device
being adapted for inclusion in a discrete multitone (DMT)
system for an asymmetric digital subscriber line (ADSL)
which has a transmitter for encoding and converting data to
20 be transmitted via a channel, said device comprising:

A/D converting means for converting said analogue data
signal received via said channel into a digital signal;

25 time-domain equalizing means for receiving said
digital signal and reducing a guard band used to remove an
interblock interference;

fast-Fourier transforming means for receiving the
output of said time-domain equalizing means and
demodulating said data signal modulated in said

transmitter;

frequency-domain equalizing means for receiving the output of said fast Fourier transforming means and compensating for a phase error of each sub-channel;

5 SNR measuring means for selecting a frame having an inserted sync block from a frame structure of said transmitted data, calculating the signal-to-noise ratios (SNRs) of respective sub-channels of said selected frame, calculating first difference values between the present
10 representative SNRs calculated above and the previous representative SNRs of each sub-channel, selecting a maximum value and minimum value among the first difference values of said respective sub-channels, obtaining a second difference value being a difference between said maximum
15 value and said minimum value, determining whether said second difference value is equal to or greater than the predetermined threshold value, and outputting to a transmitter and a receiver the signal used for correcting bit and power assigning tables of a transmitter and a
20 receiver; and

decoding means for receiving the outputs of said SNR measuring means and said frequency-domain equalizing means, resetting a slice value, and decoding said reset slice value.

25 9. An adaptive bit swapping device substantially as herein described with reference to Figure 3 with or without reference to Figures 2 and 4.

10. A discrete multitone (DMT) system for an

asymmetric digital subscriber line (ADSL) which has a transmitter for encoding and converting data to be transmitted via a channel, said system comprising an adaptive bit swapping device as claimed in any of claims 7 to 9.

5

11. An adaptive bit swapping method substantially as herein described with reference to Figure 2 with or without reference to Figures 3 and 4.



Application No: GB 9613602.3
Claims searched: 1-11

Examiner: David Midgley
Date of search: 22 October 1996

Patents Act 1977
Search Report under Section 17

Databases searched:

UK Patent Office collections, including GB, EP, WO & US patent specifications, in:
UK CI (Ed.O): H4P (PAQ,PAL,PEM)
Int CI (Ed.6): H04L 5/06,27/34
Other: ONLINE:WPI

Documents considered to be relevant:

Category	Identity of document and relevant passage	Relevant to claims
	NONE	

X	Document indicating lack of novelty or inventive step	A	Document indicating technological background and/or state of the art.
Y	Document indicating lack of inventive step if combined with one or more other documents of same category.	P	Document published on or after the declared priority date but before the filing date of this invention.
&	Member of the same patent family	E	Patent document published on or after, but with priority date earlier than, the filing date of this application.

19

(19)日本国特許庁 (J P)

(12) 特 許 公 報 (B 2)

(11)特許出願公告番号

特公平6-3956

(24) (44)公告日 平成 6年(1994) 1月12日

(51)Int.Cl. ⁵	識別記号	庁内整理番号	F I	技術表示箇所
H 0 4 M 11/00	3 0 2	8627-5K		
H 0 4 B 3/04	A	8226-5K		
H 0 4 L 1/00	E	6942-5K		
12/02		8529-5K	H 0 4 L 11/ 02	D
				発明の数 1 (全 15 頁)

(21)出願番号 特願昭61-502770

(86) (22)出願日 昭和61年(1986)5月5日

(86)国際出願番号 P C T / U S 8 6 / 0 0 9 8 3

(87)国際公開番号 W O 8 6 / 0 7 2 2 3

(87)国際公開日 昭和61年(1986)12月4日

(65)公表番号 特表昭62-502932

(43)公表日 昭和62年(1987)11月19日

(31)優先権主張番号 7 3 6 2 0 0

(32)優先日 1985年5月20日

(33)優先権主張国 米国 (U S)

(71)出願人 999999999
 テレビット コーポレイション
 アメリカ合衆国 95014 カリフォルニア
 クバーティノ パブロード 10440

(72)発明者 ヒューハートツグス ダーク
 アメリカ合衆国 95037 カリフォルニア
 モーガンヒル ローリングヒルス ドラ
 イブ 2220

(74)代理人 弁理士 鈴木 弘男

審査官 松野 高尚

(54)【発明の名称】 不完全な送信媒体のための総体的なモデム構造体

1

【特許請求の範囲】

【請求項1】各搬送波が複雑さ、即ち1回の変調で送信するビット数の変化するデータエレメントをエンコードした搬送波の集合でデータエレメントをエンコードする形式の、電話線を介してデータを送信する高速モデムにおける搬送波周波数にデータ及び電力を割り当てるシステムにおいて、

上記搬送波周波数の集合に含まれた各々の搬送波周波数に対して等化ノイズ成分を決定する手段と、

各搬送波におけるデータエレメントの複雑さ、即ち1回の変調で送信するビット数を、OとNとの間の整数をnとすれば、n個の情報単位から(n+1)個の情報単位まで増加するに要する余分な電力を決定する手段と、

上記搬送波周波数の集合に含まれたすべての搬送波の余分な電力を次第に電力が増加する順に順序付けする手段

2

と、

この順序付けされた余分な電力に次第に電力が増加する順序で利用可能な電力を割り当てる手段と、

利用可能な電力が尽きる点の値MP (max) を決定する手段と、

割り当てられる電力がその搬送波に対する上記MP (max) に等しくなり且つ割り当てられるデータ単位の数が上記MP (max) に等しいか又はそれより小さい当該搬送波のための余分な電力の数に等しくなるように各搬送波周波数に電力及びデータを割り当てる手段とを具備したことを特徴とするシステム。

【請求項2】上記の順序付け手段は、

任意の余分な電力レベルのテーブルを形成する手段と、

各々の決定された余分な電力レベルの値を上記任意の余分な電力レベルのテーブルの値の1つへと丸めて計算の

煩雑さを減少させる手段とを具備する特許請求の範囲第1項に記載のシステム。

【請求項3】モデムA及びBが電話線によって接続され、等化ノイズを決定する上記の手段は、上記モデムAとBとの間に通信リンクを確立する手段と、

上記モデムA及びBにおける非送信時間インターバル中にラインノイズデータを累積する手段と、

第1の周波数搬送波の集合を上記モデムAからBへと送信する手段とを具備し、各搬送波の振幅は所定の値を有するものであり、

更に、上記第1の周波数搬送波の集合をモデムBで受信する手段と、

モデムBで受信した各搬送波の振幅を測定する手段と、モデムBで測定した振幅を上記所定の振幅と比較して、各搬送波周波数における信号ロス(dB)を決定する手段と、

上記累積したノイズの各搬送波周波数における成分の値(dB)を決定する手段と、

各搬送波周波数における信号ロスを各搬送波周波数におけるノイズ成分に加算して等化ノイズを決定する手段とを具備する特許請求の範囲第2項に記載のシステム。

【発明の詳細な説明】

発明の背景

技術分野

本発明は、一般に、データ通信の分野に関するもので、より詳細には、高速モデムに関する。

従来技術

最近、デジタルデータを直接送信するための特殊設計の電話線が導入されている。しかしながら、膨大な量の電話線はアナログの音声周波数(VF)信号を搬送するように設計されている。モデムは、VF搬送波信号を変調してデジタル情報をVF搬送波信号にエンコードしそしてこれらの信号を復調してこの信号によって保持されたデジタル情報をデコードするのに用いられている。

既存のVF電話線は、モデムの性能を低下すると共に、所望のエラー率以下でデータを送信することのできる速度を制限するような多数の制約がある。これらの制約には、周波数に依存するノイズがVF電話線に存在することや、VF電話線によって周波数に依存する位相遅延が挿入されることや、周波数に依存する信号ロスがあることが含まれる。

一般に、VF電話線の使用可能な帯域は、ゼロより若干上から約4KHzまでである。電話線ノイズの電力スペクトルは、周波数にわたって均一に分布されず、一般的に不定なものである。従って、これまで、VF電話線の使用可能な帯域にわたるノイズスペクトルの分布を測定する方法は皆無である。

更に、周波数に依存する伝播遅延がVF電話線によって誘起される。従って、複雑な多周波数信号の場合は、V

F電話線により信号の種々の成分間に位相遅延が誘起される。この位相遅延も不定なものであり、送信が行なわれる特定の時間に個々のVF電話線について測定しなければならない。

更に、VF電話線の信号ロスは周波数と共に変化する。等価ノイズは、各搬送波周波数に対して信号ロス成分に追加されるノイズスペクトル成分であり、両成分は、デシベル(dB)で測定される。

一般に、公知のモデムは、満足なエラー率を得るようにデータ速度をダウン方向にシフトすることによって等価ラインノイズ及び信号ロスを補償している。例えば、バラン(Baran)氏の米国特許第4438511号には、ガンダルフ・データ・インク(Gandalf Data Inc.)によって製造されたSM9600スーパー・モデムと称する高速モデムが開示されている。ノイズ障害がある場合、このSM9600は、その送信データ速度を4800bps又は2400bpsに「ギヤシフト」即ち低下させる。バラン氏の特許が開示されたシステムは、64の直角変調された搬送波によってデータを送信する。バラン氏のシステムは、ライン上の大きなノイズ成分の周波数と同じ周波数を有する搬送波の送信を終らせることにより、VFライン上のノイズの周波数依存性を補償するものである。従って、バラン氏のシステムは、VFラインノイズスペクトルの最高点の搬送波周波数で送信を終らせることによりそのスループットを僅かに低下させる。バラン氏のシステムは、本質的に、VFラインノイズスペクトルの分布に基づいて各搬送波信号のゴー/ノー・ゴー判断を行なう。本発明は、バラン氏によって開始された努力を引き継ぐものである。

殆どの公知のシステムは、VFラインによって誘起される周波数依存性の位相遅延を等化システムによって補償するものである。最も大きな位相遅延は、使用可能な帯域の端付近の周波数成分において誘起される。従って、帯域の中心付近の周波数成分は、帯域の外側の周波数成分を捕獲できるように遅延される。等化を行なう場合には、一般に、上記の遅延を実行するための追加回路が必要とされる。

VF電話線を介しての両方向送信に関連した更に別の問題は、出ていく信号と入ってくる信号とで干渉を生じるおそれがあることである。一般に、2つの信号の分離及びアイソレーションは、次の3つの方法の1つで行なわれる。

(a) 別々の信号に対して別々の周波数を使用する周波数マルチプレクシング。この方法は、モデムをベースとする遠隔通信システムに通常用いられるものである。

(b) 別々の信号に対して別々の時間セグメントを使用する時間マルチプレクシング。この方法は、送信器がこれに含まれた全てのデータを送信した後のみチャンネルを放棄する半二重システムにおいてしばしば使用される。

(c) 直交コードを用いて信号を送信するコードマルチプレクシング。

上記の全てのシステムでは、利用できるスペースが、最初のシステム設計中に固定された一定の割合に基づいて分割される。しかしながら、これらの一定の割合は、各モデムに生じる実際のトラフィックロード（通信負荷）問題に適したものではない。例えば、離れたホストコンピュータに接続されたPCワークステーションにいる事務員は、10又は20個の文字をタイプし、その応答として全スクリーンを受け取る。この場合、送信側モデムと受信側モデムとの間にチャンネルを等しく割り当てる一定の割合では、PCワークステーションの事務員にチャンネルを相当過剰に割り当てることになる。従って、実際のトラフィックロード状態の必要性に応じてチャンネル容量を割り当てるモデムがあれば、チャンネル容量の効率的な利用が著しく促進される。

発明の要旨

本発明は、ダイヤル式のVF電話線に使用する高速モデムに関する。このモデムは、多搬送波変調機構を使用しており、全データ送信率を最大にするようにデータ及び電力を種々の搬送波に可変に割り当てる。搬送波間での電力の割当は、割り当てる全電力が指定の限界を越えてはならないという制約を受ける。

好ましい実施例では、上記モデムは、更に、通信リンクの制御権を実際のユーザ要求に応じて2つのモデム（A及びB）間で分担させる可変割当システムを備えている。

本発明の別の特徴は、周波数に依存する位相遅延を補償すると共に記号間の干渉を防止するシステムであって、等化ネットワークを必要としないようなシステムにある。

本発明の1つの特徴によれば、直角振幅変調（QAM）を用いて色々な複雑さ、即ち1回の変調で送信するビット数のデータエレメントが各搬送波にエンコードされる。各搬送波周波数における等価ノイズ成分は、2つのモデム（AとB）との間の通信リンクを経て測定される。

良く知られているように、ビットエラー率（BER）を指定レベル以下に維持すべき場合には、所与の搬送波周波数における所与の複雑さのデータエレメントを送信するに要する電力を、その周波数の等価ノイズ成分が増加した時に、増加しなければならない。同様に、データの複雑さ、即ち1回の変調で送信するビット数を増加するためには、信号対雑音比、即ち、S/N比を増加しなければならない。

本発明の一実施例においては、外的なBER及び全利用電力の制約内で全データ率を最大にするようにデータ及び電力が割り当てられる。電力割当システムは、各搬送波における記号率をnからn+1までの情報単位で増加するために余分な所要電力を計算する。次いで、システ

mは、記号率を1情報単位だけ増加するように最小の追加電力を必要とする搬送波に情報単位を割り当てる。余裕電力は、特に確立された送信リンクの等価ノイズスペクトルの値によって決まるので、電力及びデータの割当は、この特定のリンクについてのノイズを補償するように特に調整される。

本発明の別の特徴によれば、各搬送波における記号の第1の部分は、記号の中をTEとし、この第1部分の中をTPHとすれば、巾TE+TPHのガード時間波形を形成するように再送信される。TPHの大きさは、波形の周波数成分について推定される最大位相遅延に等しいか又はそれより大きい。例えば、記号が時間TE内に送信された時間シリーズ $x_0 \dots x_{n-1}$ によって表わされる場合には、ガード時間波形が時間TE+TPH内に送信された時間シリーズ $x_0 \dots x_{n-1}$ 、 $x_0 \dots x_{m-1}$ によって表わされる。mのnに対する比は、TPHのTEに対する比に等しい。

受信モデムにおいては、ガード時間波形の第1周波数成分の時間インターバル T_0 が決定される。巾TEのサンプリング周期は、時間 $T_0 + TPH$ において開始される。

従って、各搬送波周波数における全記号がサンプリングされ、記号間の干渉が除去される。

本発明の更に別の特徴によれば、モデムAとBとの間での送信リンクの制御の割当は、1つの送信サイクル中に各モデムが送信するパケットの数に対して限界をセットすることによって行なわれる。情報パケットは、1つの波形を構成する搬送波全体においてエンコードされたデータを備えている。又、各モデムは、モデム間の通信リンクを維持するための最小数のパケットを送信するように構成される。従って、1つのモデムが送信すべきデータを有していない場合でも、最小のパケットがタイミングを維持し、他のパラメータが送信される。一方、モデムのデータ量が多い場合には、制限された最大数のパケットNのみを送信してから他のモデムへ制御権を放棄するような制約が課せられる。

実際に、モデムAが少量のデータを有しそしてモデムBが大量のデータを有する場合には、モデムBが殆どの時間中送信リンクの制御権を有することになる。制御権が最初にモデムAに指定された場合には、これが最小数Iのパケットのみを送信する。従って、モデムAは、短い時間中のみ制御権を有する。次いで、制御権はモデムBに指定され、N個のパケットを送信する。Nは非常に大きなものである。再び、制御権はモデムAに指定され、I個のパケットを送信してから制御権をBに戻す。従って、制御権の割当は、I対Nの比に比例する。モデムAのデータ量の送信にL個のパケットが必要とされる場合（ここで、LはIとNとの間の値である）、割当は、LとNの比に比例する。従って、送信リンクの割当は、ユーザの実際の要求に基づいて変化する。

更に、パケットの最大数Nは、各モデムごとと同じである必要はなく、モデムA及びBによって送信されるべきデータの既知の不均衡を受け入れるように変えることができる。

本発明の更に別の特徴によれば、データを決定する前に信号ロス及び周波数オフセットが測定される。追従システムは、測定値からの変化を決定し、これらのずれを補償する。

本発明の更に別の特徴によれば、T₀の正確な値を決定するシステムが含まれている。このシステムは、時間T_AにモデムAから送信される波形に含まれたf₁及びf₂の2つのタイミング信号を用いている。時間T_Aにおける第1と第2のタイミング信号間の相対的な位相差はゼロである。

波形は、モデムBに受け取られ、f₁のエネルギーを検出することによって受信時間のおおよその推定値T_{EST}が得られる。この時間T_{EST}におけるタイミング信号間の相対的な位相差を用いて、正確なタイミング基準T₀が得られる。

図面の簡単な説明

第1図は、本発明に用いられる搬送波周波数全体のグラフ、

第2図は、各搬送波のQAMを示す座標のグラフ、

第3図は、本発明の実施例を示すブロック図、

第4図は、本発明の同期プロセスを示すフローチャート、

第5図は、0、2、4、5、6ビットデータエレメントに対する座標、例示的な信号対雑音比及び各座標に対する電力レベルを示す一連のグラフ、

第6図は、水充填アルゴリズムを示すグラフ、

第7図は、本発明に用いる水充填アルゴリズムの応用を示すヒストグラム、

第8図は、搬送波周波数全体の周波数成分に対する位相依存周波数遅延の影響を示すグラフ、

第9図は、記号間干渉を防止するために本発明に用いられる波形を示すグラフ、

第10図は、送信された搬送波周波数全体を受信する方法を示すグラフ、

第11図は、変調テンプレートを示す概略図、

第12図は、変調テンプレートの1つの方形の象限を示す概略図、そして

第13図は、本発明のハードウェア実施例を示す概略図である。

好ましい実施例の詳細な説明

本発明は、周波数に依存するラインノイズを補償するように周波数全体における種々の搬送波周波数間で電力を状態に応じて割り当て、周波数に依存する位相遅延を補償するための等化回路の必要性を排除し、変化するチャンネルロード状態を考慮して送信側モデムと受信側モデムとの間でチャンネルを割り当てる二重機構を形成する

ようなモデムに関する。本発明の更に別の特徴は、以下で述べる。

本発明の理解を容易にするために、本発明に用いられる周波数全体及び変調機構を第1図及び第2図について最初に簡単に説明する。次いで、第3図を参照して、本発明の特定の実施例を説明する。最後に、第4図ないし第13図を参照して、本発明の動作及び種々の特徴を説明する。

変調及び全体の構成

10 第1図は、本発明の送信周波数全体10を示す概略図である。これは、使用可能な4KHzのVF帯域にわたって等しく離間された512個の搬送波周波数12を含んでいる。本発明は、各搬送波周波数における位相に拘りないサイン及びコサイン信号を送信するような直角振幅変調(QAM)を用いている。所与の搬送波周波数で送信されるデジタル情報は、その周波数における位相に拘りないサイン及びコサイン信号を振幅変調することによってエンコードされる。

20 QAMシステムは、全ビット率RBでデータを送信する。しかしながら、記号もしくはボーレートRSで示された各搬送波の送信率は、RBの一部分に過ぎない。例えば、データが2つの搬送波間に等しく割り当てられる場合には、RS=RB/2となる。

30 好ましい実施例では、0、2、4、5又は6ビットデータエレメントが各搬送波においてエンコードされ、各搬送波の変調は136ミリ秒ごとに変化する。各搬送波について6ビットのRSを仮定すれば、理論的な最大値RBは、22580ビット/秒(bps)となる。搬送波の75%にわたって4ビットのRSを仮定すれば、典型的に実現できるRSは、約11300bpsに等しい。この例示的な高いRSは、ビットエラー率が1エラー/10000送信ビット未満の状態で達成される。

第1図において、複数の垂直線14は、周波数全体を「エポック」と称する時間増分に分割する。エポックは、巾がTEであり、TEの大きさは以下で述べるように決定される。

デジタルデータを種々の搬送波周波数にエンコードするQAMシステムを第2図について説明する。第2図には、第n番目の搬送波に対する4ビット「座標」20が示されている。4ビット数は、16の個々の値をとることができる。この座標における各点は、ベクトル(x_n, y_n)を表わしており、x_nはサイン信号の振幅であるy_nは磁気QAMシステムにおけるコサイン信号の振幅である。付随の文字nは、変調される搬送波を示している。従って、4ビット座標では、4つの個々のy_nの値と、4つの個々のx_nの値とが必要とされる。以下で詳細に述べるように、所与の搬送波周波数で送信されるビットの数を増加するためには、その周波数に等価ノイズ成分があるために、電力を増加することが必要とされる。4ビット送信の場合、受信側のモデムは、x_n及

び y_n 振幅係数の4つの考えられる値を弁別できねばならない。この弁別能力は、所与の搬送波周波数に対する信号対雑音比によって左右される。

好ましい実施例では、パケット技術を用いてエラー率が減少される。1つのパケットは、搬送波の変調されたエポックと、エラー検出データとを含んでいる。各パケットは、エラーが生じた場合、修正されるまで繰返し送信される。或いは又、データの繰返し送信が所望されないシステムでは、ホワードエラー修正コードを含むエポックが用いられる。

ブロック図

第3図は、本発明の実施例のブロック図である。これについて説明すると、発振側モデム26は、公共のスイッチ式電話線を経て形成された通信リンクの発振端に接続される。通信システムには、通信リンクの応答端に接続された応答モデムも含まれることを理解されたい。以下の説明において、発振モデムの同じ又は同様の部分に対応する応答モデムの部分は、発振モデムの参照番号にプライム（'）記号を付けて示す。

第3図を説明すると、入ってくるデータ流は、モデム26の送信システム28によりデータ入力30に受け取られる。データは、一連のデータビットとしてバッファメモリ32に記憶される。バッファメモリ32の出力は、変調パラメータ発生器34の入力に接続される。変調パラメータ発生器34の出力は、ベクトルテーブルバッファメモリ36に接続され、該バッファメモリ36は変調器40の入力に接続される。変調器40の出力は、時間シーケンスバッファ42に接続され、次いで、該バッファ42は、アナログI/Oインターフェイス44に含まれたデジタル/アナログコンバータ43の入力に接続される。インターフェイス44は、モデムの出力を公共のスイッチ式電話線48に接続する。

受信システム50は、公共のスイッチ式電話線48に接続されてインターフェイス44に含まれたアナログ/デジタルコンバータ(ADC)52を備えている。ADC52の出力は受信時間シリーズバッファ54に接続され、該バッファは、次いで、復調器56の入力に接続される。復調器56の出力は、受信ベクトルテーブルバッファ58に接続され、該バッファは、次いで、デジタルデータ発生器60の入力に接続される。このデジタルデータ発生器60の出力は、受信データビットバッファ62に接続され、該バッファは、出力端子64に接続される。

制御及びスケジューリングユニット66は、変調パラメータ発生器34、ベクトルテーブルバッファ36、復調器56及び受信ベクトルテーブルバッファ58に接続されている。

第3図に示された実施例の機能について概略的に説明する。データを送信する前に、発振モデム26は、応答モデム26' と協働して、各搬送波周波数における等価ノ

イズレベルを測定し、各搬送波周波数で送信されるべきエポック当たりのビット数を決定し、以下で詳細に述べるように、各搬送波周波数に電力を割り当てる。

入ってくるデータは、入力ポート30で受け取られ、入力バッファ32に記憶されるビットシーケンスにフォーマット化される。

変調器34は、上記のQAMシステムを用いて、所与の数のビットを各搬送波周波数のための (x_n, y_n) ベクトルにエンコードする。例えば、周波数 f_n で4つのビットを送信することが決定された場合には、ビット流からの4つのビットが第2図の4ビット座標内の16個の点の1つに変換される。これら座標点の各々は、4つのビットの16個の考えられる組合せの1つに対応する。従って、周波数 n に対するサイン及びコサイン信号の振幅は、ビットシーケンスの4つのビットをエンコードする座標内の点に対応する。 (x_n, y_n) ベクトルは、次いで、ベクトルバッファテーブル36に記憶される。変調器は、周波数全体に含まれた搬送波のための (x_n, y_n) ベクトルのテーブルを受け取り、QAM搬送波周波数の全体を構成する波形を表わすデジタルエンコード化された時間シリーズを形成する。

好ましい実施例では、変調器40は、高速フーリエ変換器(FFT)を備えており、 (x, y) ベクトルをFFT係数として用いて逆FFT演算を実行する。ベクトルテーブルは、512周波数座標の1024個のFFT点を表わす1024の個々の点を含んでいる。逆FFT演算により、QAM全体を表わす1024個の点が時間シリーズで形成される。このデジタルエンコードされた時間シリーズの1024個のエレメントは、デジタル時間シリーズバッファ42に記憶される。デジタル時間シリーズは、アナログ/デジタルコンバータ43によりアナログ波形に変換され、インターフェイス46は、公共のスイッチ式電話線48を経て送信するように信号を調整する。

受信システム50について説明すれば、公共のスイッチ式電話線48から受信したアナログ波形は、インターフェイス46によって調整され、アナログ/デジタルコンバータ52は、アナログ波形をデジタルの1024入力時間シリーズテーブルに変換し、これは、受信時間シリーズバッファ54に記憶される。復調器56は、1024入力時間シリーズテーブルを512入力 (x_n, y_n) ベクトルテーブルに変換し、これは、受信ベクトルテーブルバッファ58に記憶される。この変換は、時間シリーズに基づいてFFTを実行することにより行なわれる。各周波数搬送波にエンコードされたビットの数に関する情報は、復調器及びデジタルデータ発生器60に既に記憶されており、従って、受信ベクトルテーブルバッファ58に記憶された (x, y) テーブルは、デジタルデータ発生器60により出力データビットシーケンスに変換

されることに注意されたい。例えば (x_n, y_n) ベクトルが4ビットのシーケンスを表わす場合には、このベクトルがデジタルデータ発生器60により4ビットシーケンスに変換されそして受信データビットバッファ62に記憶される。受信データビットシーケンスは、次いで、出力データ流として出力64へ送られる。

使用するFFT技術の完全な説明は、1975年N.

J. のプレントイス・ホール・インク (Prentice-Hall, Inc.,) により出版されたラビナ (Rabiner) 氏等の「デジタル信号処理の理論及び応用 (Theory and Applications of Digital Signal Processing)」と題する文献に述べられている。しかしながら、上記したFFT変調技術は、本発明の重要な部分ではない。或いは又、参考としてここに取り上げる前記バランの特性のカラム10、ライン13-70及びカラム11、ライン1-30に述べられたように、搬送波トーンを直接乗算することによって変調を行なうこともできる。更に、バランの特許のカラム12、ライン35-70、カラム13、ライン1-70及びカラム14、ライン1-13に述べられた復調システムと取り替えることもできる。

制御及びスケジューリングユニット66は、一連の動作を全体的に監視するように維持し、入力及び出力機能を制御する。

等価ノイズの測定

上記したように、各周波数搬送波にエンコードされたデータエレメント及びその周波数搬送波に割り当てられた電力の情報内容は、その搬送波周波数におけるチャンネルノイズ成分の大きさによって左右される。周波数 f_n における等価送信ノイズ成分 $N(f_n)$ は、周波数 f_n における測定した(受信した)ノイズ電力に、周波数 f_n における測定した信号ロスを乗算したものである。等価ノイズはラインごとに変化し、所与のラインにおいても時間ごとに変化する。従って、ここに示すシステムでは、データ送信の直前に $N(f)$ が測定される。

この $N(f)$ を測定して、応答及び発振モデム26と26'との間に通信リンクを確立するために本システムに用いられる同期技術の段階が第4図に示されている。第4図を説明すれば、ステップ1において、発振モデムは応答モデムの番号をダイヤルし、応答モデムはオフ・フックの状態となる。ステップ2において、応答モデムは、次の電力レベルで2つの周波数のエポックを送信する。

(a) 1437. 5Hz: -3dB

(b) 1687. 5Hz: -3dB

電力は、基準値Rに対して測定し、好ましい実施例では、0dB=-9dBmであり、mはミリボルトである。これらのトーンは、以下で詳細に説明するように、タイミング及び周波数オフセットを決定するのに用いられる。次いで、応答モデムは、全部で512の周波数を含む応答コームを-27dBで送信する。発振モデムは、この

応答コームを受け取り、このコームにおいてFFTを実行する。512個の周波数の電力レベルは指定の値にセットされるので、応答モデム26の制御及びスケジューリングユニット66は、受信したコードの各周波数に対して (x_n, y_n) 値を比較し、これらの値を、送信された応答コードの電力レベルを表わす (x_n, y_n) 値のテーブルと比較する。この比較により、VF電話線を通しての送信による各周波数の信号ロスが得られる。ステップ3の間に、発振モデム26及び応答モデム26'の両方は、各々のモデムによる送信が行なわれない場合にラインに存在するノイズデータを累積する。次いで、両方のモデムは、累積されたノイズ信号に基づいてFFTを実行し、各搬送波周波数における測定した(受信した)ノイズスペクトル成分値を決定する。多数のノイズエポックを平均化して、測定値の精度を高める。

ステップ4において、発振モデムは、2つの周波数のエポックと、それに続いて、512の周波数の発振コームを、ステップ2について述べたものと同じ電力レベルで送信する。応答モデムは、エポック及び発振コームを受け取り、ステップ2の発振モデムについて述べたように各搬送波周波数におけるタイミング、周波数ずれ及び信号ロスの値を計算する。この点において、発振モデム26は、ノイズ及び信号ロスデータを応答発振方向に送信するように累積しており、一方、応答モデムは、発振応答方向の送信に関連する同じデータを累積している。各モデムは、発振応答方向及び応答発振方向の両方における送信ロス及び受信ノイズに関連したデータを必要とする。それ故、このデータは、同期プロセスの残りのステップに基づいて2つのモデム間で交換される。

ステップ5において、発振モデムは、どの搬送波周波数が標準電力レベルの2ビット送信を応答発振方向に維持するかを示す第1の位相エンコード信号を発生して送信する。標準電力レベルで応答発振方向に2ビットを維持する各成分は、 180° の相対的な位相を有した-28dB信号として発生される。標準電力レベルで応答発振方向に2ビット送信を維持しない各成分は、 -28 で 0° の相対的な位相の信号としてコード化される。応答モデムは、この信号を受信し、どの周波数搬送波が応答発振方向に2ビットの送信を維持するかを決定する。

ステップ6において、応答モデムは、どの搬送波周波数が発振応答方向及び応答発振方向の両方に2ビット送信を維持するかを示す第2の位相エンコード信号を発生し送信する。この信号を発生できるのは、応答モデムが発振応答方向のノイズ及び信号ロスデータを累積しており且つステップ5で発振モデムにより発生された信号において応答発振方向に対して同じデータを受信しているからである。発振モデムによって発生された信号において、2つのビットを両方向に維持する各周波数成分は、 180° の相対的な位相でコード化され、他の全ての成分は、 0° の相対的な位相でコード化される。

これで、2つのモデム間に送信リンクが存在する。一般に、300ないし400個の周波数成分が標準電力レベルの2ビット送信を維持し、これにより、2つのモデム間に約600ビット/エポック率を確立する。ステップ7では、この存在するデータリンクを経て形成される全体的なパケットにおいて応答発振方向に各周波数で維持することのできるビットの数(0-15)及び電力レベル(0-63dB)に関するデータを発振モデムが送信する。従って、ここで、発振及び応答モデムの両方は、応答発振方向の送信に関するデータをもつことになる。各周波数成分に維持することのできるビットの数及び電力レベルを計算するためのステップについて以下に述べる。

ステップ8において、応答モデムは、存在するデータリンクを用いて発振応答方向に各周波数に維持することのできるビットの数及び電力レベルに関するデータを送信する。従って、両モデムは、応答発振及び発振応答の両方向において各周波数成分に維持すべきビットの数及び電力レベルが分かる。

各搬送波周波数における等価ノイズレベル成分の決定に関する上記の説明では、所与のシーケンスの所要のステップが説明された。しかしながら、これらの一連のステップはあまり重要ではなく、多くのステップは同時に行なってもよいし別の順序で行なってもよい。例えば、発振コードに基づくFFTの実行とノイズデータの累積を同時に行なうことができる。又、同期プロセス中に正確なタイミング基準も計算される。このタイミング基準の計算は、各周波数成分に割り当てられたビットの数及び電力レベルを計算する方法を説明した後に、詳細に述べる。

送信信号と受信信号との間に7Hzまでの周波数オフセットが存在するのは、一般のVF電話線の障害である。FFTを確実に機能させるためには、このオフセットを補正しなければならない。好ましい実施例では、この補正は、受信信号の真の像及びヒルバート像によりオフセット周波数における直角トーンの片側波帯変調を行なうことにより達成される。同期及び追従アルゴリズムにより、必要な周波数オフセットの推定値が形成される。

電力及びコードの複雑さ、即ち1回の変調で送信するビット数の指定

各搬送波周波数信号にエンコードされた情報は、復調器56により受信チャンネルにおいてデコードされる。チャンネルノイズは、送信信号を歪ませ、復調プロセスの精度を低下させる。例えば、特定の周波数 f_0 に B_0 個のビットがあるという特定の複雑さ、即ち1回の変調で送信するビット数を有するデータエレメントを、等価ノイズレベル成分 N_0 により特徴付けられたVF電話線を経て送信する場合について分析する。一般に、外部システムの条件により、許容できる最大ビットエラー率が決定される。ノイズレベル N_0 及び周波数 f_0 で b_0 個の

ビットを送信する場合には、信号対雑音比が E_b/N_0 以上でなければならない。但し、 E_b は、BERを所与のBER(BER_0)より小さく維持するための信号電力/ビットである。

第5図は、種々の複雑さ、即ち1回の変調で送信するビット数 B の信号に対するQAM座標を示している。各座標に対する例示的な信号対雑音比 E_b/N_0 と、上記の(BER_0)を越えずにこの座標におけるビットの数を送信するに要する電力とが、各座標グラフの横に示されている。

モデムは、公共のスイッチ式電話線に出力される全利用電力が電話会社及び政府機関によって設定された値 P_0 を越えないという制約のもとで作動する。従って、ラインノイズを補償するために信号電力が不定に増加することはない。それ故、所要のBERを維持するためには、ノイズが増加するにつれて、送信信号の複雑さ、即ち1回の変調で送信するビット数を低減しなければならない。

殆どの既存のモデムは、ラインノイズ電力が増加する時に、信号の複雑さ、即ち1回の変調で送信するビット数をダウン方向に任意にギヤシフトする。例えば、1つの公知のモデムは、ビットエラー率が指定の最大値以下に減少されるまで、送信データ率を、9600bpsの最大値から、7200bps、4800bps、2400bps、1200bps、等々の段階で低下させる。従って、信号率は、ノイズを補償するように大きな段階で減少される。バラン氏の特許においては、送信率を減少する方法は、ノイズスペクトルの周波数依存性を考慮するものである。従って、各チャンネルは、プリセットされた数のビットを指定の電力レベルで保持している。各周波数のノイズ成分が測定され、各搬送波周波数で送信すべきであるかどうかについて判断がなされる。従って、バラン氏の特許では、データ率減少機構が、利用できる帯域中にわたるノイズの実際の分布を補償する。

本発明では、各周波数搬送波における信号の複雑さ、即ち1回の変調で送信するビット数及び各周波数搬送波に割り当てられた利用可能な電力の量がラインノイズスペクトルの周波数依存性に応答して変化する。

全周波数内の周波数成分信号に種々のコードの複雑さ、即ち1回の変調で送信するビット数及び電力レベルを指定する本システムは、水充填アルゴリズムに基づくものである。水充填アルゴリズムは、チャンネルを横切る情報の流れを最大にするようにチャンネルの電力を指定する情報理論的な方法である。チャンネルは、ノイズ分布が不均一である形式のもので、送信器は電力の制約を受ける。第6図は、水充填アルゴリズムを目で見て分かるようにするものである。第6図について説明すれば、電力は垂直軸に沿って測定され、周波数は水平軸に沿って測定される。等価ノイズスペクトルは実線60で表わされ、利用可能な電力は、交差斜線領域72によって表わ

される。水充填という名称は、指定電力を表わす或る量の水が充填される山間の一連の谷に等価ノイズ関数が類似していることから付けられたものである。水は谷を満たし、水平面をとる。水充填アルゴリズムの理論的な説明は、1968年、ニューヨーク、J. Wiley and Sons出版の「情報理論及び信頼性のある通信 (Information Theory And Reliable Communication)」と題するガラハー (Gallagher) 氏の文献に述べられている。

水充填理論は、種々のコード (全てエラー修正のためのもの) を用いて達成できる全てのデータ率の最大値として容量が定められ且つ無限の長さであることが最良の傾向であるようなチャンネルの理論的な容量を最大にすることに關するものである点を強調しておく。

本発明による方法は、チャンネルの容量を最大にするものではない。むしろ、本発明の方法は、第1図について上記したように利用可能な電力に制約のあるQAM全体を用いて送信される情報の量を最大にするものである。水充填の考え方の実行は、指定の電力レベルが第2の最低搬送波の等価ノイズレベルに達するまで最低の等価ノイズフロアを有する搬送波に利用可能な電力の増分を割り当てることである。この割当を行なう場合には、512の周波数を走査しなければならない。

次いで、第3の最低チャンネルの等価ノイズレベルに達するまで2つの最低搬送波の間で増分電力が割り当てられる。この割当レベルの場合には、周波数テーブルを何回も走査することが必要で、計算上から非常に複雑である。

本発明の好ましい実施例に用いる電力の割当方法は、次の通りである。

(1) 受信器において等価ノイズを測定しそして送信ロスで乗算することにより送信器におけるシステムノイズを計算する。これらの量を測定するこのプロセスは、第4図を参照し同期について上記で説明した。システムノイズ成分は、各搬送波周波数について計算される。

(2) 各搬送波周波数に対し、色々な複雑さ (ここに示す場合には、0, 2, 4, 5, 及び6) のデータエレメントを送信するに必要な電力レベルを計算する。これは、所要のBER、例えば、1エラー/100000ビットで種々のデータエレメントを送信するに必要な信号対雑音比によって等価ノイズを乗算することにより行なわれる。全BERは、変調された各搬送波の信号エラー率の和である。これらの信号対雑音比は、標準的な基準から得られ、この分野で良く知られている。

(3) 計算された所要の送信電力レベルから、データエレメントの複雑さ、即ち1回の変調で送信するビット数を増加するに必要な余分な電力レベルが決定される。これらの余分な所要の電力レベルは、送信電力の差を、複雑さ、即ち1回の變調で送信するビット数が最も接近し

ているデータエレメントの複雑さ、即ち1回の變調で送信するビット数の量的な差で除算したものである。

(4) 各々のチャンネルについて、余分な所要電力レベル及び量的な差の2カラムテーブルを形成する。それらの単位は、典型的に、各々ワット及びビットで表わされる。

(5) 次第に大きくなる余分な電力に従って上記ステップ4のテーブルを編成することによりヒストグラムを構成する。

10 (6) 利用できる電力が尽きるまで、次第に大きくなる余計な電力に対して利用できる送信電力を順次に指定する。

上記の電力割当方法は、簡単な例によって良く理解できよう。この例に含まれる数値は、オペレーティングシステムにおいて遭遇するパラメータを表わすものではない。

表1は、周波数 f A 及び f B の2つの搬送波 A 及び B に対し、選択されたビット数 N₁ のデータエレメントを送信するための所要電力 P を示している。

表 1			
搬 送 波 A			
N ₁	N ₂ - N ₁	P	MP(N ₁ ~ N ₂)
0	—	0	—
2	2	4	MP(0~2) = 2/ビット
4	2	12	MP(2~4) = 4/ビット
5	1	19	MP(4~5) = 7/ビット
6	1	29	MP(5~6) = 10/ビット
搬 送 波 B			
N ₁	N ₂ - N ₁	P	MP(N ₁ ~ N ₂)
0	—	0	—
2	2	6	MP(0~2) = 3/ビット
4	2	18	MP(2~4) = 6/ビット
5	1	29	MP(4~5) = 11/ビット
6	1	44	MP(5~6) = 15/ビット

第1のビット数 N₁ から第2のビット数 N₂ へ複雑さ、即ち1回の變調で送信するビット数を増加するための余分な電力は、次の関係式によって定められる。

$$M P (N _ { 1 } \sim N _ { 2 }) = \frac{P _ { 2 } - P _ { 1 }}{N _ { 2 } - N _ { 1}}$$

但し、P₂ 及び P₁ は、複雑さ、即ち1回の變調で送信するビット数 N₂ 及び N₁ のデータエレメントを送信するに必要な電力である。N₂ - N₁ は、データエレメントの複雑さ、即ち1回の變調で送信するビット数の量的な差である。BERは、プリセット限界以下に保つように制限されることを理解されたい。

周波数 f A に対する余分な電力は、周波数 f B に対するものよりも少ない。というのは、f B における等価ノイズ N (f B) が f A における等価ノイズ N (f A) より大きいからである。

搬送波A及びBの割当機構に実施について以下に述べる。全ビット数NTが周波数全体にエンコードされるが、搬送波AにもBにもビットが割り当てられていないものと仮定する。例えば、 $N(f_A)$ 及び $N(f_B)$ は、既にデータを保持しているこれらの搬送波の電力よりも大きい。

この例では、システムは、全データエレメントの複雑さ、即ち1回の変調で送信するビット数を最大量だけ増加するために利用可能な残りの10個の電力単位を搬送波AとBとの間で割り当てる。

NTを2ビットだけ増加するためには、チャンネルAを用いる場合は4単位の電力を割り当てねばならず、チャンネルBを用いる場合は6単位の電力を割り当てねばならない。というのは、両チャンネルに対して $N_1 = 0$ 及び $N_2 = 2$ でありそしてチャンネルAに対して $MP(0 \sim 2) = 2/\text{ビット}$ 、チャンネルBに対して $MP(0 \sim 2) = 3/\text{ビット}$ であるからである。それ故、システムは、4単位の電力を搬送波Aに割り当て、2ビットデータエレメントを搬送波Aにコード化し、全信号の複雑さ、即ち1回の変調で送信するビット数をNTからNT+2に増加し、残りの利用可能な電力単位が6となる。2ビットを更に増加する場合には、搬送波Aに対して $MP(2 \sim 4) = 4/\text{ビット}$ で且つチャンネルBに対して $MP(0 \sim 2) = 3/\text{ビット}$ であるから、電力単位が6つが必要である。それ故、システムは、6単位の電力を搬送波Bに割り当て、2ビットデータエレメントを搬送波Bにエンコードし、全信号の複雑さ、即ち1回の変調で送信するビット数をNT+2からNT+4ビットに増加し、残りの利用可能な電力単位はゼロとなる。

ここで明らかのように、システムは、種々の搬送波周波数の中で電力コストが最低のものを「買い(s h o p)」、全データエレメントの複雑さ、即ち1回の変調で送信するビット数を増加させる。

割当システムは、周波数を最初に走査する間に各搬送波に対し最初に表1を形成することによって全部で512個の搬送波全体まで拡張される。

次いで、全ての搬送波に対して計算された余計な所要電力レベルを次第に大きくなる電力に従って編成したヒストグラムが構成される。第7図は、本発明の方法により構成した例示的なヒストグラムを示している。

第7図には、余計な電力の全体的な表が示されていない。むしろ、このヒストグラムは、0.5dBのステップでカウント値が離された6.4dBの範囲を有するように構成される。ステップとステップとの間の量的な差がカウントとして用いられる。この解決策では若干の丸めエラーが生じるが、作業の長さを著しく低減することができる。ヒストグラムを構成するのに用いる方法は、本発明を実施するのに重要ではない。

ヒストグラムの各カウントは、そのカウントにおける電力値に等しい余分な電力値を有する搬送波の数を表わし

ている整数入力を持している。このヒストグラムは、最低の電力レベルから走査される。各カウントの整数入力は、カウントの数値で乗算され、利用可能な電力から減算される。走査は、利用可能な電力が尽きるまで続けられる。

走査が完了すると、所与のレベルMP(max)より低い全ての余計な電力値が電力及びデータの割当に受け入れられることが決定される。更に、利用可能な電力が余計な電力レベルMP(max)を通して部分的に尽きた場合には、k個の追加搬送波に、MP(max+1)に等しい電力が割り当てられる。

次いで、システムは、種々の搬送波に電力及びデータを割り当てるために再び周波数全体を走査する。各搬送波に割り当てられる電力の量は、MP(max)に等しいか又はそれより小さい当該搬送波に対する余分な電力値の和である。これに加えて、kMP(max+1)の値がそれまで割り当てられていない場合には、MP(max+1)に等しい電力の量が割り当てられる。

タイミング及び位相遅延の補償

20 受信システムによって(x, y)ベクトルテーブルを再構成する場合には、受信した波形を1024回サンプリングすることが必要である。帯域巾は約4KHzであり、従って、ナイキストのサンプリング率は約8000/秒で、サンプル間の時間サンプルオフセットは125マイクロ秒である。従って、全サンプリング時間は128ミリ秒である。同様に、送信FFTは、1024の入力を有する時間シリーズを発生し、記号時間は128ミリ秒である。

サンプリングプロセスでは、サンプリングを開始するためのタイミング基準が必要とされる。このタイミング基準は、同期中に次の方法によって確立される。第4図を参照して定められた同期ステップ中には、発振モデムが時間TESTに応答コームにおける1437.5Hzの周波数成分(第1のタイミング信号)のエネルギーを検出する。上記の時間は、第1のタイミング周波数成分が受信器に到達する正確な時間のおおよその尺度であり、一般に、約2ミリ秒までの精度である。

このおおよその尺度は、次の段階によってその精度が高められる。第1のタイミング信号及び第2のタイミング信号(1687.5Hz)は、エポックマークにおいて相対的な位相がゼロの状態を送信される。

50 発振モデムは、時間TESTにおいて第1及び第2のタイミング信号の位相を比較する。第1と第2のタイミング信号間に250Hzの周波数差があると、各125マイクロ秒の時間サンプルオフセットに対し2つの信号間に11°の位相ずれが生じる。第1及び第2のタイミング信号は、それらの位置が帯域の中心付近にあるために相対的な位相歪みが僅かである(250マイクロ秒未満)。従って、2つのタイミングサンプルの位相を比較しそして位相差によって指示された時間サンプリングオ

フセットの個数でTESTを修正することにより、正確なタイミング基準T₀を決定することができる。サンプリングプロセスをタイミングどりすることに関連した更に別の問題は、周波数に依存した位相遅延がVFラインによって誘起されることである。この位相遅延は、典型的に、VF電話線の場合には、約2ミリ秒或いはそれ以上である。更に、この位相遅延は、4KHzの使用帯域の端付近では著しく悪化する。

第8図は、周波数に依存する位相遅延を受けた後の全周波数の周波数搬送波の分布を示している。第8図を説明すれば、周波数f₀、f₂₅₆及びf₅₁₂に3つの信号90、94、及び92が示されている。長さがTsの2つの記号x_i及びy_iは、各周波数において送信される。各記号の中は、不変であることに注意されたい。しかしながら、帯域90及び92の端付近の信号の先縁は、帯域94の中心付近のこれら信号に対して遅延される。

更に、2つの順次に送信されたエポックx_i及びy_iについては、帯域の外端付近にある信号92及び96上の第1記号x_iの後部が、帯域の中心付近にある記号94上の第2記号y_iの先端に重畳する。この重畳により、記号間の干渉が生じる。

サンプリングインターバルが所与の時間インターバルTsでサンプリングするように枠付けされる場合には、全周波数における各搬送波の完全なサンプルが得られず、他のエポックからの信号がサンプリングされる。

既存のシステムは、位相修正(等化)回路網を用いて位相歪みを補償すると共に記号間の干渉を防止する。

本発明は、独特なガード時間フォーマットを用いて等化回路網の必要性を排除するものである。このフォーマットが第9図に示されている。

第9図を説明すれば、時間シリーズx_i、y_i及びz_iによって各々表わされた第1、第2及び第3の送信記号が示されている。第9図に示された波形は、周波数fの搬送波の1つに変調される。この例では、記号時間Tsが128ミリ秒で、最大位相遅延TPHが8ミリ秒であると仮定される。ガード時間波形は、136ミリ秒のエポックを定める。例えば、第1の波形110(x_i)においては、記号の時間シリーズX₀-X₁₀₂₃が最初に送信され、次いで、記号の最初の8ミリ秒X₀-X₈が繰り返される。

エポックのサンプリングは、ガード時間波形の最後の128ミリ秒に揃えされる(最初に到着する周波数成分によって定められたガード時間エポックの開始に対して)。

この検出プロセスが第10図に示されている。第10図において、帯域の中心付近のf₁と、帯域の端付近のf₂とにおける第1及び第2のガード時間波形110及び112が示されている。f₁における周波数成分は、受信器に最初に到着する全周波数のうちの成分であり、f

2における成分は、最後に到着する成分である。第10図において、f₂の第2の波形112は、f₁の第1の波形110が受信器に到着する時間T₀後の時間T₀+TPH(8ミリ秒)に受信器に到着する。この時間T₀+TPHに128ミリ秒のサンプリング時間が開始される。従って、f₂の全記号X₀-X₁₀₂₃がサンプリングされる。その記号の最初の8ミリ秒が再送信されるので、f₁の全記号もサンプリングされる。

又、記号間の干渉も排除される。f₁の第2記号(y_i)の到着は、(x_i)の最初の8ミリ秒の再送信によって、8ミリ秒遅延される。従って、f₁の第2記号の先端は、f₂の第1記号の後端と重畳しない。

8ミリ秒のガード時間は、システムの使用可能な時間と帯域中との積を約6%減少するに過ぎない。この僅かな減少は、必要なガード時間に対して各記号の中が非常に長いことによるものである。

追従

実際に、所与の搬送波については、復調プロセス中に抽出される(x, y)ベクトルの大きさが厳密に座標点に入らず、ノイズ及び他のファクタにより各点のまわりに或る程度分布される。従って、信号は、第11図に示された変調テンプレートを用いてデコードされる。

第11図を説明すれば、テンプレートは方形113のグリッドで形成され、方形113の中心には座標点114が設けられている。

第11図において、ベクトルW=(x_n, y_n)は、f_nにおけるサイン及びコサイン信号の復調された振幅を表わしている。Wは、座標点(3, 3)を中心とする方形113内にある。従って、Wは、(3, 3)とデコードされる。

本発明は、同期中に決定された値からの送信ロス、周波数オフセット及びタイミングの変化を決定するように追従を行なうシステムを備えている。

この追従システムは、第11図の復調テンプレートの方形における受信ベクトルの位置を利用するものである。

第12図において、1つの方形が、左下、右上、左上及び右下、各々、115、116、117及び118の4つの象限に分けられており、これらは、各々、速過ぎ、遅過ぎ、大き過ぎ、小さ過ぎを表わしている。これら4つの全ての象限におけるカウントが、或る周波数において或る時間に及ぶものも、或る時間において或る周波数に及ぶものも、互いに等しいか又はほぼ等しい場合には、システムが整列状態にある。即ち、ノイズが唯一の障害である場合には、デコードされたベクトルWに対するエラーの方向がランダムとなる。

しかしながら、送信ロスが0.1dBでも変化する場合に、小さ過ぎるカウントの数が大き過ぎるカウントの数から著しく変化する。同様に、速過ぎるカウントの数と遅過ぎるカウントの数との差が大きい場合には、オフセット周波数の変化によって位相の回転が生じたことを示

10

20

30

40

50

している。従って、速過ぎ、遅過ぎ及び大き過ぎ、小さ過ぎのカウンタ間の差は、信号ロス及びオフセット周波数の変化に追従するエラー特となる。

本発明は、このエラー特性を用いて、同期中に決定された信号ロス及び周波数オフセットを調整するものである。各周波数に対し、 $\pm 0.1\text{dB}$ 又は $\pm 1.0^\circ$ の調整がエラー特性に基づいて行なわれる。或る実施例では、デコード領域を、速過ぎ、遅過ぎ、大き過ぎ、小さ過ぎという個別の又は重畳するサブ領域に別のやり方で分割するのが好ましい。

更に、タイミング信号の位相は、 T_0 を修正できるように追従される。

チャンネル制御権の指定

本発明は、更に、確立された通信リンクの制御権を発振モデムと応答モデム（各々、A及びBと称する）の間で指定する独特のシステムを具備している。エンコードされた全周波数で構成される各波形は、情報パケットを形成する。

通信リンクの制御権は、最初に、モデムAに指定される。次いで、モデムAは、その入力バッファにおけるデータの量を決定し、I（最小）とN（予め定めた最大）のデータパケットの間で適当に送信を行なう。所定数Nは限界として働き、送信されるパケットの最終的な個数は、入力バッファを空にするに必要なものよりも著しく小さい。一方、モデムAがその入力バッファに殆ど或いは全くデータを有していない場合には、モデムBとの通信を維持するために依然としてI個の情報パケットを送信する。例えば、I個のパケットは、第4図及び同期プロセスについて述べた周波数の発振又は応答コムを含む。

次いで、通信リンクの制御権はモデムBに指定され、該モデムは、モデムAの動作を繰り返す。もちろん、モデムBが最小数Iのパケットを送信する場合には、モデムBが働いていることをモデムAに知らせる。

迅速な文字やエコーや他のユーザ向けの目標を達成するために、2つのモデムの限界Nを同じものにしたたり或いはモデム制御のもとでこれらモデムの適用を制限したりする必要はない。

ハードウェアの実施

第13図は、本発明のハードウェア実施例を示すブロック図である。第13図を説明すれば、電子的なデジタルプロセッサ120、アナログI/Oインターフェイス44及びデジタルI/Oインターフェイス122が共通のデータバス124に接続されている。アナログI/Oインターフェイス44は、公共のスイッチ式電話線48を共通のデータバス124にインターフェイスし、デジタルインターフェイス122は、デジタルターミナル装置126を共通のデータバス124にインターフェイスする。

本発明の好ましい実施例では、次の部品が使用される。

アナログI/Oインターフェイス44は、高性能の12ビットコーダ・デコーダ（コーデック）及び電話線インターフェイスである。このインターフェイスは、RAM132をアクセスし、監視マイクロプロセッサ128によって制御される。コーデックは、アナログ/デジタルコンバータ、デジタル/アナログコンバータ及び多数のバンドパスフィルタを単一のチップに組み合わされたものである。

デジタルI/Oインターフェイス122は、標準的な25ピンのRS232型コネクタに対する標準的なRS232直列インターフェイスであるか或いはパーソナルコンピュータバスに対する並列インターフェイスである。電子的なデジタルプロセッサ120は、アドレスバス135に接続された監視プロセッサ128と、汎用の数学プロセッサ130と、 $32\text{K} \times 16$ ビットの共用RAMサブシステム132と、リードオンメモリ（ROM）ユニット133とを備えている。

監視マイクロプロセッサ128は、10MHzの68000プロセッサ及び68000プログラムメモリを含む68000データプロセッササブシステムである。 $32\text{K} \times 16$ ビットのプログラムメモリは、ROMユニット133に含まれた多数の低電力高密度のROMチップで構成される。

数学プロセッサ130は、20MHzの320プロセッサ、320プログラムメモリ及び共用RAMシステムのインターフェイスを含む320デジタル信号マイクロプロセッサシステム（DSP）である。ROMユニット133に含まれた2つの高速ROMチップは、 8192×16 ビットのプログラムメモリを構成する。

320システムのプログラムメモリは、変調テーブルのルックアップ、FFT、復調及び上記の他の動作を実行するプログラムを含んでいる。68000プロセッサは、入力及び出力のデジタルデータ流を処理し、320信号プロセッサ及びそれに関連したアナログI/Oへのタスク及びその監視を実行し、そしてそれ自体及びシステムのテストを適宜実行する。

本発明は、特定の実施例について説明した。他の実施例は、今や、当業者に明らかであろう。

特に、搬送波周波数全体は、上記したように制限しなくてもよい。搬送波の数は、2の累乗、例えば、1024でもよいし、他の任意の数でもよい。更に、周波数は、全VF帯域にわたって均一に離間されてなくてもよい。更に、QAM機構は、本発明の実施にとって重要ではない。例えば、AMを使用してもよいが、データ率RBが低下する。

更に、変調テンプレートは方形で構成する必要がない。座標点を取り巻く任意の形状の領域を画成することができる。追従システムは、変調テンプレートの方形を4つの象限に分割したものについて説明した。しかしながら、座標点の周りに画成された任意の領域におけるカウ

23

24

ント数の差を追跡することにより所与のパラメータを追跡することができる。
 更に、監視マイクロプロセッサ及び汎用の数学プロセッサを含むハードウェア実施例についても説明した。しかしながら、色々な組合わせのICチップを使用することができる。例えば、専用のFFTチップを用いて、変調*

及び復調動作を実行することができる。
 更に、上記で用いた情報単位はビットであった。しかし、本発明は、2進システムに限定されるものではない。それ故、本発明は、請求の範囲のみによって限定されるものとする。

【第1図】

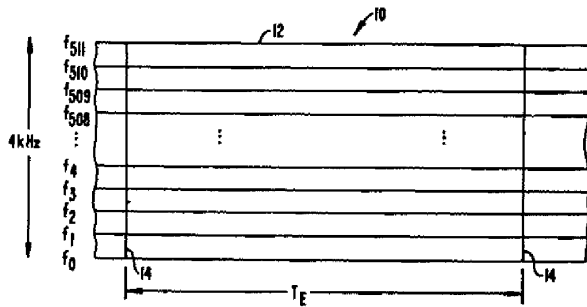

【第2図】

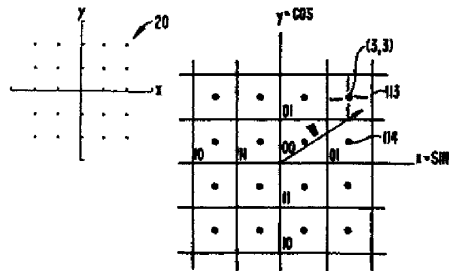

【第11図】

【第3図】

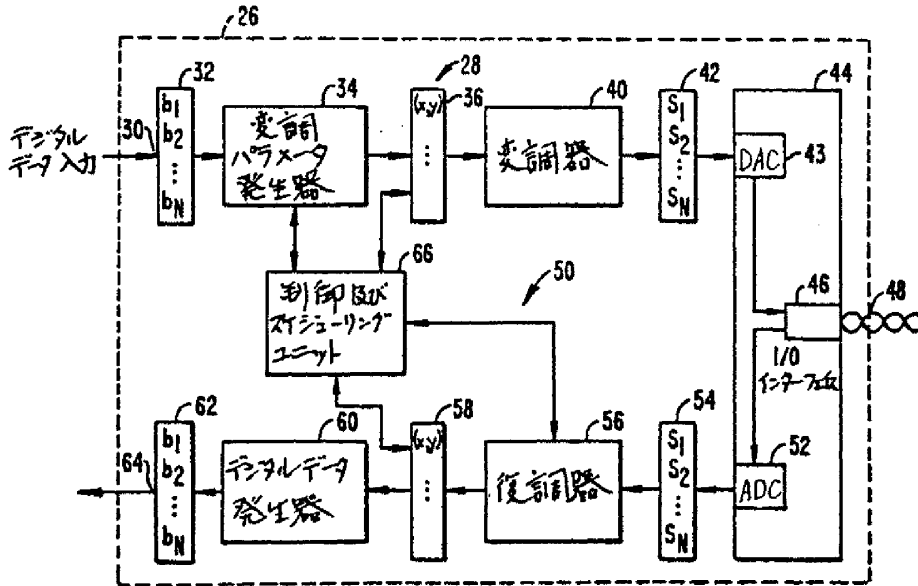

【第9図】

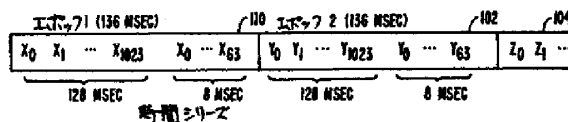

【第4図】

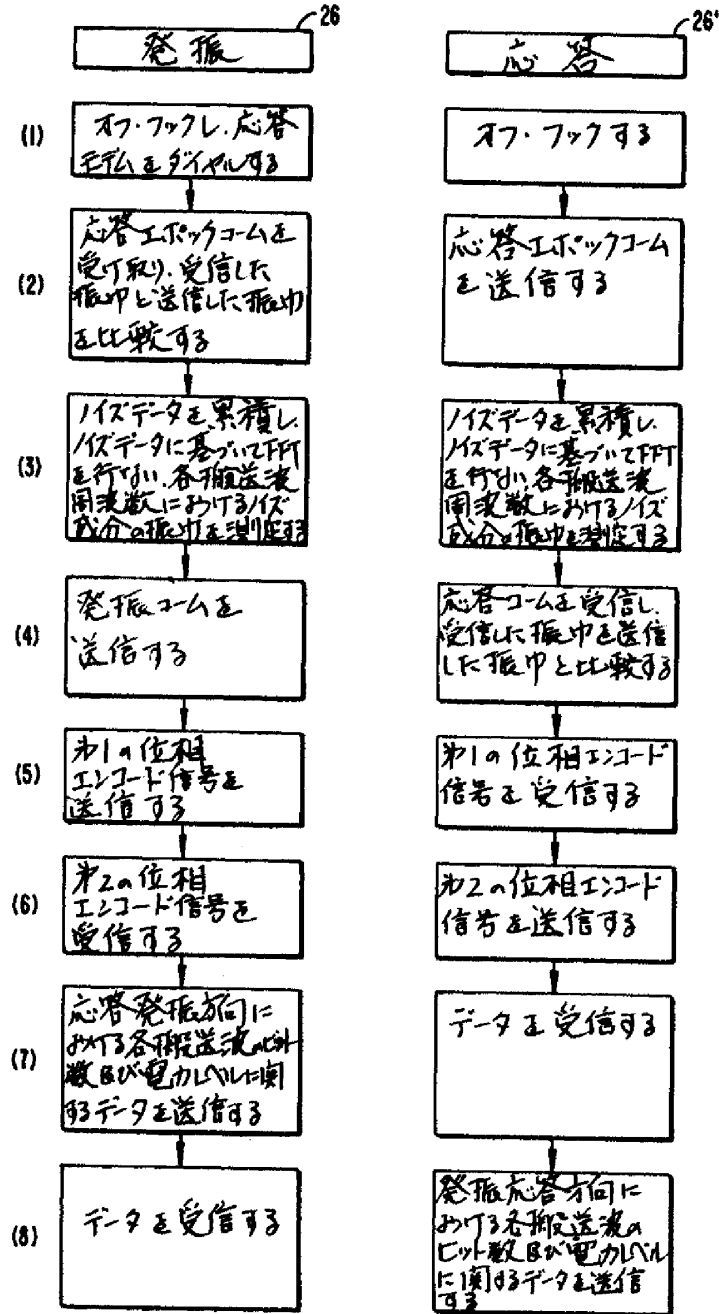

【第5図】

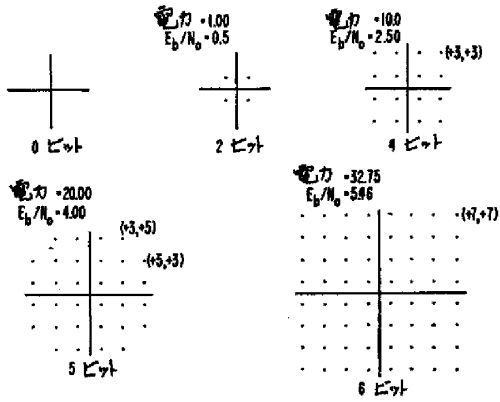

【第6図】

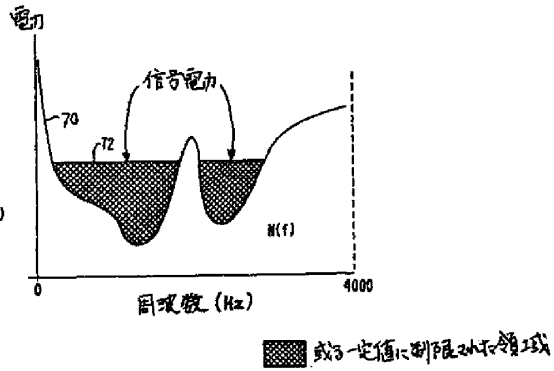

【第7図】

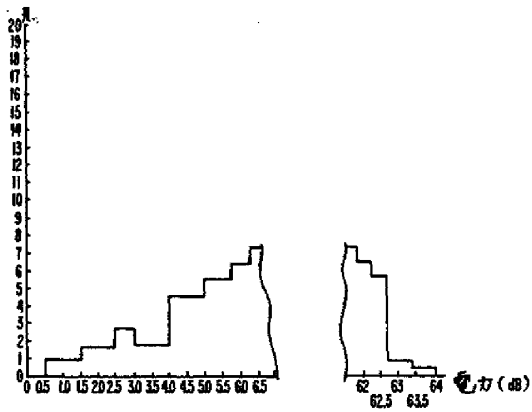

【第10図】

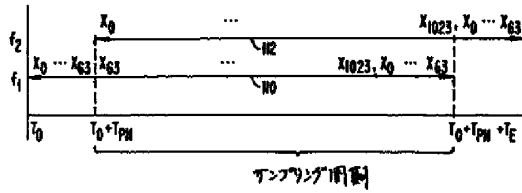

【第8図】

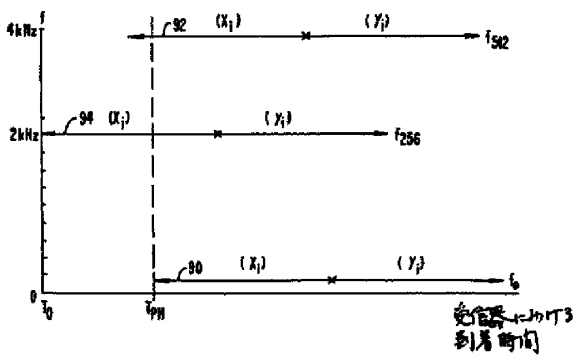

【第12図】

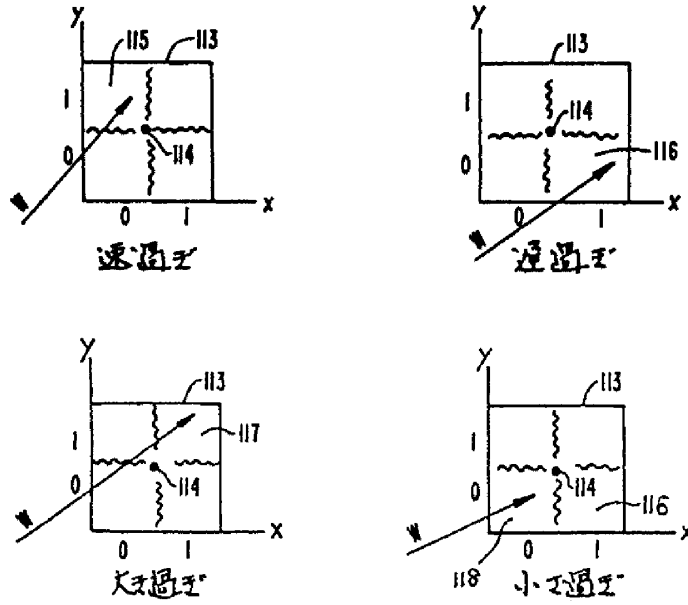

【第13図】

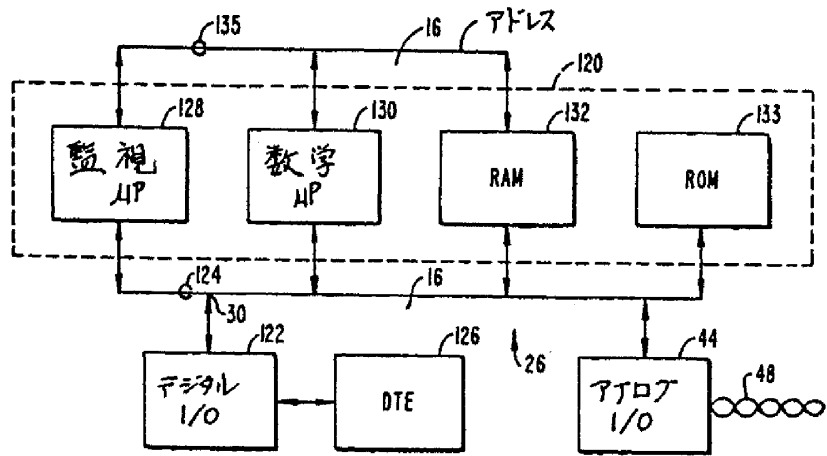

METHOD OF COMMUNICATION CHANNEL MONITORING USING PARITY BITS

Publication number: JP10513622 (T)
Publication date: 1998-12-22
Inventor(s):
Applicant(s):
Classification:

Also published as:

- WO9624995 (A2)
- WO9624995 (A3)
- TW409475 (B)
- EP0808534 (A2)
- CN1193433 (A)

more >>

- international: H04N7/16; H04B10/207; H04J3/14; H04J3/16; H04L1/00; H04L1/24; H04L5/02; H04L5/14; H04L25/03; H04L27/26; H04M11/06; H04N7/173; H04L27/00; H04N7/16; H04B10/207; H04J3/14; H04J3/16; H04L1/00; H04L1/24; H04L5/02; H04L5/14; H04L25/03; H04L27/26; H04M11/06; H04N7/173; H04L27/00; (IPC1-7): H04L1/00; H04J3/14; H04J3/16; H04M11/06; H04N7/16

- European: H04N7/173B; H04J3/14; H04L1/00B7B; H04L1/24; H04L5/02Q; H04L5/14T2; H04L25/03E3; H04L27/26M2; H04L27/26M3; H04L27/26M5; H04L27/26M5A1P; H04L27/26M5C3

Application number: JP19960524387T 19960206
Priority number(s): WO1996US01606 19960206; US19950384659 19950206; US19950457295 19950601

Abstract not available for JP 10513622 (T)
Abstract of corresponding document: WO 9624995 (A2)

A method for monitoring at least one telephony communication n-bit channel, wherein one of the bits is a parity bit, includes sampling the parity bit of the n-bit channel. A probable bit error rate is derived from the sampling of the parity bit. The probable bit error rate can be compared to a pre-determined bit error rate value to determine if the at least one telephony communication n-bit channel is corrupted. If the at least one telephony communication n-bit channel is corrupted, the at least one telephony communication n-bit channel is re-allocated to an uncorrupted and unallocated telephony communication n-bit channel. Further, at least one unallocated telephony communication channel can be periodically monitored and error data accumulated to indicate the quality thereof.

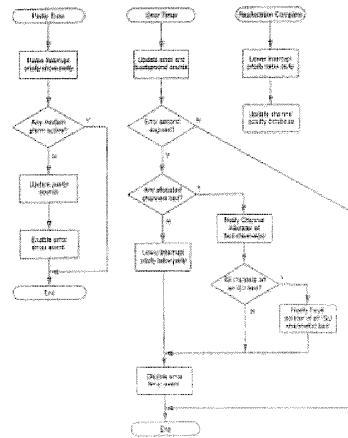

Data supplied from the *espacenet* database — Worldwide

(51) Int.Cl. ⁶	識別記号	F I	
H 0 4 L	1/00	H 0 4 L	1/00 C
H 0 4 J	3/14	H 0 4 J	3/14 Z
	3/16		3/16 Z
H 0 4 M	11/06	H 0 4 M	11/06
H 0 4 N	7/16	H 0 4 N	7/16 Z
		審査請求	未請求 予備審査請求 有 (全144頁)

(21) 出願番号 特願平8-524387
 (86) (22) 出願日 平成8年(1996)2月6日
 (85) 翻訳文提出日 平成9年(1997)8月6日
 (86) 国際出願番号 PCT/US96/01606
 (87) 国際公開番号 WO96/24995
 (87) 国際公開日 平成8年(1996)8月15日
 (31) 優先権主張番号 08/384,659
 (32) 優先日 1995年2月6日
 (33) 優先権主張国 米国 (US)
 (31) 優先権主張番号 08/457,295
 (32) 優先日 1995年6月1日
 (33) 優先権主張国 米国 (US)

(71) 出願人 エーディーシー テレコミュニケーションズ、インコーポレイティド
 アメリカ合衆国、ミネソタ 55435、ブルーミントン、ウエスト セブンティエイス ストリート 4900
 (72) 発明者 アンダーソン、ブライアン ディー、アメリカ合衆国、ミネソタ 55442、プリマウス、フィフティース プレイス ノース 11430
 (74) 代理人 弁理士 石田 敬 (外3名)

最終頁に続く

(54) 【発明の名称】 通信チャンネルをモニタする方法

(57) 【要約】

少なくとも1つの電話通信nビットチャンネルをモニタする方法であって、該ビットの1つはパリティビットであり、該nビットチャンネルのパリティビットをサンプリングすることを含む。予想されるビットエラー率は該パリティビットのサンプリングから求められる。該予想されるビットエラー率は、少なくとも1つの電話通信nビットチャンネルがこわれているかどうかを決定するために、予め定められたビットエラー率の値と比較される。もし少なくとも1つの電話通信nビットチャンネルがこわれているならば、該少なくとも1つの電話通信nビットチャンネルは、こわれておらずかつ割当てられていない電話通信nビットチャンネルに再割当てされる。更に、少なくとも1つの割当てられていない電話通信チャンネルが周期的にモニタされ、エラーデータがその品質を示すために累積される。

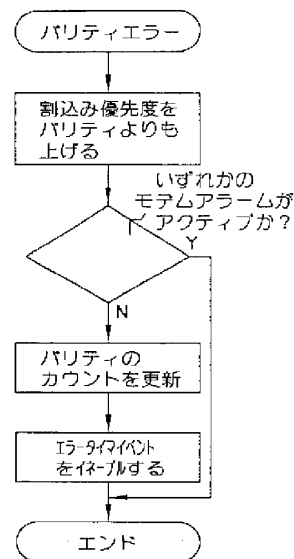

FIG. 29A

【特許請求の範囲】

1. 少なくとも1つの電話通信nビットチャネルをモニタする方法であって、該ビットの1つがパリティビットであり、
該nビットチャネルのパリティビットをサンプリングするステップと、
該パリティビットのサンプリングから予想されうるビットエラー率を求めるステップとを具備する方法。
2. 少なくとも1つの割当てられていない電話通信チャネルに対して、エラーデータを周期的にモニタし累積するステップを更に備えた、請求項1に記載の方法。
3. 少なくとも1つの電話通信nビットチャネルがこわれているかどうかを決定するために、予想されうるビットエラー率を、予め決定されたビットエラー率の値と比較するステップと、
もし少なくとも1つの電話通信nビットチャネルがこわれているならば、該少なくとも1つの電話通信nビットチャネルを、こわれておらずかつ割当てられていない電話通信nビットチャネルに再割当てするステップとを更に備えた、請求項1に記載の方法。
4. 少なくとも1つの電話通信nビットチャネルがこわれているかどうかを決定するために、予想されうるビットエラー率を、予め決定されたビットエラー率の値と比較するステップと、
もし該nビットチャネルがこわれているならば、システム全体の電力を維持している間、該nビットチャネルの伝送パワーを増加するステップとを更に備えた、請求項1に記載の方法。
5. 少なくとも1つの電話通信nビットチャネルをモニタする方法であって、該ビットの1つがパリティビットであり、
該nビットチャネルのパリティビットをサンプリングするステップと、
ある期間に亘って該パリティビットのサンプリングから予想されうるビットエラー率を求めるステップと、

該 n ビットチャネルがこわれているかどうかを決定するために、ある期間に亘って予想されうるビットエラー率を予め定められたビットエラー率の値と比較するステップとからなる方法。

6. 該比較にもとづいて、該 n ビットチャネルから異なる n ビットチャネルに通信を再割当てするステップを更に備える、請求項 5 に記載の方法。

7. 少なくとも 1 つの電話通信 n ビットチャネルが、複数の電話通信の n ビットチャネルの帯域内に含まれており、該帯域が少なくとも 1 つの制御チャネルと関連しており、更に異なる n ビットチャネルが該帯域内に配置されている、請求項 6 に記載の方法。

8. 少なくとも 1 つの電話通信 n ビットチャネルが複数の電話通信 n ビットチャネルの帯域内に含まれており、該帯域は少なくとも 1 つの制御チャネルと関連しており、更に異なる n ビットチャネルが、他の少なくとも 1 つの関連した制御チャネルを有する複数の電話通信 n ビットチャネルの第 2 の帯域に配置されている、請求項 6 に記載の方法。

9. もし該 n ビットチャネルがこわれているならば、システム全体の電力を維持している間、該 n ビットチャネルの伝送パワーを増加するステップを更に備えた、請求項 5 に記載の方法。

10. テーブル内に予想されうるビットエラー率を記憶するステップを更に備え、該テーブルは n ビットチャネル上の将来の通信を割当てするために使用されうる、請求項 5 に記載の方法。

11. もし該チャネルがこわれていないならば、少なくとも 1 つのより長い期間に亘ってパリティビットをサンプリングすることから

少なくとも 1 つの付加的な予想されうるビットエラー率を求めるステップと、

該 n ビットチャネルがこわれているかどうかを決定するために、該少なくとも 1 つの付加的な予想されうるビットエラー率を付加的な予め定められたビットエラー率の値と比較するステップとを更に備えた、請求項 5 に記載の方法。

12. 予め定められたビットエラー率の値は電話通信サービスのためであり、付加的な予め定められたビットエラー率の値は、付加的な電話通信サービスのため

である、請求項11に記載の方法。

13. 電話通信サービスの1つはISDNである、請求項12に記載の方法。

14. もし該nビットチャネルがこわれているならば、システム全体の電力を維持している間、該nビットチャネルの伝送パワーを増加させるステップを更に備えた、請求項11に記載の方法。

15. 該少なくとも1つの付加的な予想されうるビットエラー率と付加的な予め定められたビットエラー率の値との比較にもとづいて、該nビットチャネルから異なるnビットチャネルへ該通信を再割当てするステップを更に備えた、請求項11に記載の方法。

16. 少なくとも1つの電話通信nビットチャネルをモニタする方法であって、該ビットの1つがパリティビットであり、

第1の期間に亘って該nビットチャネルのパリティビットをサンプリングするステップと、

該第1の期間に亘る該パリティビットのサンプリングから予想されうるビットエラー率を求めるステップと、

該nビットチャネルがこわれているかどうかを決定するために該第1の期間に亘っての該予想されうるビットエラー率を予め定められたビットエラー率の値と比較するステップと、

もし該nビットチャネルがこわれていないならば、複数の連続する期間に亘って予想されうるビットエラー率を累積するステップとを備えた方法。

17. 該nビットチャネルがこわれているかどうかを決定するために、該連続する期間に亘っての該累積された予想されうるビットエラー率を、少なくとも1つの付加的な予め定められたビットエラー率の値と比較するステップを更に備えた、請求項16に記載の方法。

18. もし該nビットチャネルがこわれているならば、該nビットチャネルからの通信を第2のnビットチャネルに再割当てするステップを更に備えた、請求項17に記載の方法。

19. もし該nビットチャネルがこわれているならば、システム全体の電力を維

持している間、該 n ビットチャネルの伝送パワーを増加するステップを更に備えた、請求項17に記載の方法。

20. 該予め定められたビットエラー率の値は電話通信サービスと関連しており、また該少なくとも1つの付加的な予め定められたビットエラー率の値は、少なくとも1つの付加的な電話通信サービスと関連している、請求項19に記載の方法。

21. 該電話通信サービスの1つはISDNである、請求項20に記載の方法。

22. もし該 n ビットチャネルがこわれているならば、該 n ビットチャネルから第2の n ビットチャネルに通信を再割当てするステップを更に備えた、請求項16に記載の方法。

23. もし該 n ビットチャネルがこわれているならば、システム全体の電力を維持している間、該 n ビットチャネルの伝送パワーを増加するステップを更に備えた、請求項16に記載の方法。

24. 少なくとも1つの電話通信 n ビットチャネルをモニタする方法であって、該ビットの1つはパリティビットであり、

該 n ビットチャネルのパリティビットをサンプリングするステップと、

第1の期間に亘って該パリティビットをサンプリングすることから予想されるビットエラー率を求めるステップと、

該 n ビットチャネルがこわれているかどうかを決定するために、該第1の期間に亘っての予想されるビットエラー率を第1の予め定められたビットエラー率の値と比較するステップと、

第2の期間に亘って該パリティビットをサンプリングすることから予想されるビットエラー率を求めるステップであって、該第2の期間は該第1の期間より長くされていて該第1の期間と同時に経過するものと、

該 n ビットチャネルがこわれているかどうかを決定するために該第2の期間に亘って該予想されるビットエラー率を第2の予め定められたビットエラー率の値と比較するステップとを備えた方法。

25. もし該 n ビットチャネルがこわれていなければ、該 n ビットチャネルから

第2のnビットチャンネルに通信を再割当てするステップを更に備えた、請求項24に記載の方法。

26. もし該nビットチャンネルがこわれていれば、システム全体の電力を維持している間、該nビットチャンネルの伝送パワーを増加させるステップを更に備えた、請求項24に記載の方法。

27. テーブル内に該予想されうるビットエラー率を記憶するステップを更に備え、該テーブルはnビットチャンネル上の将来の通信を割当てるために使用される、請求項24に記載の方法。

28. 少なくとも1つの割当てられていない電話通信チャンネルをモニタする方法であって、

該少なくとも1つの割当てられていない電話通信チャンネルを周期的にモニタするステップと、

該少なくとも1つの割当てられていない電話通信チャンネルに対するエラーデータを累積するステップと、

該少なくとも1つの割当てられていない電話通信チャンネルを、該エラーデータにもとづいて、割当てられるのを許容するステップとからなる方法。

29. こわされた電話通信チャンネルから、少なくとも1つの割当てられていない電話通信チャンネルに、電話通信を再割当てするステップを更に備えた、請求項28に記載の方法。

30. 少なくとも1つの割当てられていない電話通信チャンネルを周期的にモニタする方法であって、

遠隔の送信機から、複数ビットの1つがパリティビットであるnビットの信号を送信するステップと、

nビットチャンネルのパリティビットをサンプリングするステップと、

該サンプリングされたパリティビットから予想されうるビットエラー率を求めるステップとを含む、請求項28記載の方法。

31. 割当てられていないチャンネルがパワーダウンされた割当てチャンネルである方法であって、

該チャンネルがモニタされうるように、割当てられていないチャンネル上の遠隔の位置で遠隔のトランスミッタをパワーアップするステップと、

該チャンネルがモニタされた後で該遠隔のトランスミッタをパワーダウンするステップとを更に含む、請求項28に記載の方法。

32. 該チャンネルがこわれているかどうかを決定するために、予想されうるビットエラー率を予め定められたビットエラー率と比較するステップを更に備えた、請求項28に記載の方法。

33. 少なくとも1つの割当てられていない電話通信チャンネルが、

複数の割当てられていない電話通信チャンネルの1つであり、少なくとも或る数の割当てられていない電話通信チャンネルがモニタされる方法であって、このようなモニタリングにもとづいて少なくとも或る数の割当てられていないチャンネルの品質をランク付けするステップを含む、請求項28に記載の方法。

34. 該ランク付けするステップは、高品質のチャンネルをスタンバイチャンネルとしてわきにセットすることを含む、請求項33に記載の方法。

【発明の詳細な説明】

通信チャンネルをモニタする方法

発明の分野

本発明は一般的には通信システムの分野に関し、特に本発明は通信チャンネルのモニタリングに関する。

発明の背景

最近、家庭とビジネスで見出される2つの情報サービスにはテレビジョン又はビデオサービスおよび電話サービスを含む。他の情報サービスにはデジタルデータ転送を含み、これはしばしば電話サービスに接続されたモデムを用いて達成される。ここでの電話に対するすべての更なる引用には、電話サービスとデジタルデータ転送サービスを含む。

電話とビデオの各信号の特性は異なっており、したがって電話とビデオの各ネットワークは異なる設計がなされる。例えば、電話情報は、ビデオ信号に対する帯域幅と比較したとき、比較的狭い帯域を占有する。更に、電話信号は低周波数であるのに対し、NTSC基準ビデオ信号は50MHzより高いキャリア周波数で伝送される。したがって電話伝送ネットワークはオーディオ周波数で動作する比較的狭い帯域幅システムであり、このシステムは通常壁受側接合ボックスから降下するねじれたワイヤによって顧客にサービスする。他方、ケーブルテレビジョンサービスは広帯域であり、従来の非常に高い周波数のテレビジョン受信器と両立しうる信号を達成するために種々の周波数キャリア混合方法を組み込む。ケーブルテレビジョンシステム又はビデオサービスは典型的には各個々家庭又はビジネスへのシールドされたケーブルサービス接続を通してケーブルテレビジョン会社によって提供される。

電話及びビデオサービスを単一のネットワークに組合せる1つの試みは、“光通信ネットワーク”と題するBalanceへの米国特許4,977,593号に記載されている。Balanceには中央局に配置された光源を有する受動的な光通信網が記載されている。該光源は光ファイバーに沿って時分割多重光信号を送信し、この信号はいくつかの個別的ファイバーをサービスする支所間の一連のスプリットによって後

で分割される。該ネットワークは同じ光学的経路を介して、デジタル音声データが支所から中央局まで伝送されるのを許容する。更に Balanceは付加的な波長がデジタル多重を介して該ネットワークへ、ケーブルテレビジョンのようなサービスを加えるために利用されうることを示している。

James A.Chiddixと David M.Pangracによる“ファイバー“バックボーン：進化論的なケーブルTVネットワークアーキテクチャに対する提案”と題する1988年NCTAテクニカルペーパーには、ハイブリッド光ファイバー／同軸ケーブルテレビジョン（CATV）システムのアーキテクチャについて記載されている。該アーキテクチャは既存の同軸CATVネットワークで構成する。該アーキテクチャは既存のCATV分配システムにおけるヘッドエンドからいくつかのフィードポイントへの直接的な光ファイバー経路の使用を含む。

“光波伝送ラインを用いたCATV分配ネットワーク”と題するPidgeonに対する米国特許第 5,153,763号には、ヘッドエンドから複数の加入者への広帯域多重チャンネルCATV信号の分配に対するCATVネットワークについて記載されている。ヘッドエンドにおける電気から光へのトランスミッタおよびファイバーノードにおける光から電気へのレシーバは、広帯域CATV電気信号に対応する光信号を発射させ

かつ受信する。光ファイバーノードからの分配は、同軸ケーブルの伝送ラインに沿って電気信号を送信することによって得られる。該システムは、すべての又は一部の広帯域CATV信号を1オクターブより小さい周波数範囲にブロック変換することによって、送信された広帯域CATV信号のひずみを減少させる。“光波伝送ラインを使用したCATV分配ネットワーク”と題する Pidgeonに対する関連米国特許第 5,262,883号には更にひずみを減少させるシステムについて記載されている。

上述の各ネットワークはハイブリッド光ファイバー／コアックスアーキテクチャを含む、種々のアーキテクチャに亘って広帯域ビデオ信号を送信することに対する種々の概念を示している。しかしこれらの参照例のいずれにも電話通信に対するコストのかからないフレキシブルな通信システムについて記載されていない。いくつかの問題は、かかる通信システムにおいて固有のものである。

1つのかかる問題は、使用される帯域幅が割当てられた帯域幅を超えないよう

にトランスポートデータに対して使用される帯域幅を最適化する必要性である。帯域幅の条件は、多対1の通信において特に重要であり、ここでは遠隔のユニットにある多くのトランスミッタが、割当てられた帯域幅を超えないように適応されなければならない。

第2の問題はシステムの電力消費を含む。通信システムはデータのトランスポートに対し遠隔のユニットにおいて用いられる電力を最小にすべきである。その理由は、送受信に対して遠隔のユニットで利用される設備は、システムの伝送メディアに亘って分配される電力によって供給されうるからである。

データの完全さにも配慮されなければならない。内部および外部の干渉は通信の品質を低下させる。内部干渉はシステムに亘ってト

ランスポートされるデータ信号の間に存在する。すなわち共通の通信リンクに亘ってトランスポートされるデータ信号は、それらの間で干渉を経験し、データの完全性を低下させる。外部供給源からのイングレスもまたデータ伝送の完全性に影響を及ぼす。電話通信ネットワークは外部供給源によって発生されるHAM無線のような“ノイズ”の影響を受け易い。このようなノイズは間欠的で強度が変化しうるので、システムに亘ってデータをトランスポートする方法は正確でまたこのようなイングレスの存在を避けるべきである。

これらの問題およびその他については、質の高い通信システムに対する必要性を示す以下の記述から明らかとなるであろう。

発明の概要

多対1の通信システムに固有の問題のいくつかを配慮した、特にイングレスに関して配慮したチャンネルモニタリングの使用について記述される。本発明のモニタ方法は、複数ビットの1つがパリティビットである電話通信nビットチャンネルをモニタする。該nビットチャンネルのパリティビットはサンプリングされ、該パリティビットのサンプリングから予想されうるビットエラー率が求められる。

1実施例では、ある期間に亘る該予想されうるビットエラー率が、該nビットチャンネルがこれわているかどうかを決定するために、最小ビットエラー率を表す予め定められたビットエラー率の値と比較される。こわれたチャンネルは再割当て

されうるか、又は他の実施例では、その崩壊を克服するために該チャンネルの伝送パワーが増加されうる。

別の方法の実施例では、該方法は、第1の期間に亘って該nビットチャンネルのパリティビットをサンプリングするステップと、該第1の期間に亘るパリティビットのサンプリングから予想されうるビ

ットエラー率を求めるステップと、該第1の期間に亘る該予想されうるビットエラー率を、該nビットチャンネルがこわれているかどうかを決定するために予め定められたビットエラー率の値と比較するステップと、もし該nビットチャンネルがこわれていなければ複数の連続する期間に亘って予想されうるビットエラー率を累積するステップとをそなえる。

更に他の方法の実施例では、該方法は、該nビットチャンネルのパリティビットをサンプリングするステップと、第1の期間に亘る該パリティビットのサンプリングから予想されうるビットエラー率を求めるステップとをそなえる。該第1の期間に亘る該予想されうるビットエラー率は、該nビットチャンネルがこわれているかどうかを決定するために、第1の予め定められたビットエラー率の値と比較される。第2の期間に亘るパリティビットのサンプリングから予想されうるビットエラー率が求められる。該第2の期間は該第1の期間より長く、かつ同時に経過する。該nビットチャンネルがこわれているかどうかを決定するために、該第2の期間に亘る予想されうるビットエラー率が、第2の予め定められたビットエラー率の値と比較される。

更に他の変形実施例においては、少なくとも1つの割当てられていない電話通信チャンネルをモニタする方法は、少なくとも1つの割当てられていない電話通信チャンネルを周期的にモニタすることを含む。該少なくとも1つの割当てられていない電話通信チャンネルに対するエラーデータは累積され、該少なくとも1つの割当てられていない電話通信チャンネルは該エラーデータにもとづいて割当てられる。

図面の簡単な説明

図1は、ハイブリッドファイバー／コアックス分配ネットワークを用いた本発明による通信システムのブロック図を示す。

図2は、図1のシステムの別の実施例である。

図3は、図1のシステムのトランスミッタおよびレシーバに関連したホストデジタル端末(HDT)の詳細なブロック図である。

図4は、図3の関連したトランスミッタおよびレシーバのブロック図である。

図5は、図1のシステムの光分配ノードのブロック図である。

図6は、図1のホーム統合サービスユニット(HISU)又はマルチ統合サービスユニット(MISU)のような、統合サービスユニット(ISU)の一般的なブロック図である。

図7A, 7B, 7Cは、図3のHDTに利用されるデータフレーム構造およびフレームシグナリングを示す。

図8は、図3のコアックスマスターユニット(CXMU)のコアックスマスターカード(CXMC)の一般的なブロック図である。

図9Aは、図1のシステムにおける電話トランスポートに対する第1のトランスポート実施例に対するスペクトル割当てを示す。

図9Bは、QAM変調に対するマッピング図を示す。

図9Cは、BPSK変調に対するマッピング図を示す。

図9Dは、図9Aのスペクトル割当てに対するサブバンド図を示す。

図10は、図1のシステムの第1のトランスポート実施例に対するCXMUのマスターコアックスカード(MCC)下り伝送アーキテクチャのブロック図である。

図11は、図1のシステムの第1のトランスポート実施例に対するMISUのコアックストランスポートユニット(CXTU)下りレシーバアーキテクチャのブロック図である。

図12は、図1のシステムの第1のトランスポート実施例に対するHISUのコアックスホームモジュール(CXHM)下りレシーバアーキテクチャのブロック図である。

図13は、図12のCXHM下りレシーバアーキテクチャと関連したCXHM上り伝送アー

キテクチャのブロック図である。

図14は、図11のCXTU下りレシーバアーキテクチャと関連したCXTU上り伝送アーキテクチャのブロック図である。

図15は、図10のMCC下り伝送アーキテクチャと関連したMCC上りレシーバアーキテクチャのブロック図である。

図16は、図1のシステムで使用される獲得物分配ループルーチンのフローチャートである。

図17は、図1のシステムで使用されるトラッキング分配ループ体系ルーチンのフローチャートである。

図18は、図15のMCC上りレシーバアーキテクチャの多相フィルタバンクのマグニチュード応答を示す。

図19は、図18のマグニチュード応答の一部拡大図である。

図20は、図15のMCC上りレシーバアーキテクチャのイングレスフィルタ構成およびFFTのブロック図である。

図21は、図20のイングレスフィルタ構成およびFFTの多相フィルタ構造のブロック図である。

図22Aは、第1のトランスポート実施例の下りレシーバアーキテクチャのキャリア、振幅、タイミング再生ブロックのブロック図である。

図22Bは、第1のトランスポート実施例のMCC上りレシーバアーキテクチャのキャリア、振幅、タイミング、再生ブロックのブロック図である。

図23は、第1のトランスポート実施例のレシーバアーキテクチャに対する内部イコライザ動作のブロック図である。

図24は、図1はシステムにおけるトランスポートに対する第2のトランスポート実施例のスペクトル割当てである。

図25は、図1のシステムの第2のトランスポート実施例に対するCXMUのMCCモデムアーキテクチャのブロック図である。

図26は、図1のシステムの第2のトランスポート実施例に対するHISUの加入者モデムアーキテクチャのブロック図である。

図27は、図26の加入者モデムアーキテクチャのモデムのブロック図である。

図28は、図1のシステムで用いられるチャンネルモニタに対するブロック図である。

図29A、29B、29Cは、図28のチャンネルモニタルーチンのエラーモニタ部分に対するフローチャートである。

図29Dは、図29Bに対する別のフローチャートである。

図30は、図28のチャンネルモニタルーチンのバックグラウンドモニタ部分に対するフローチャートである。

図31は、図28のチャンネルモニタルーチンのバックアップ部分に対するフローチャートである。

好適な実施例の詳細な説明

通信システム10は、本発明の図1に示すように、ハイブリッドファイバー・同軸（HFC）分散ネットワーク11上で家庭及びビジネス電話通信サービスを提供するために主として設計されたアクセスプラットフォームである。システム10は、電話やビデオサービスの提供にとって価格的に有効なプラットフォームである。電話サービスは標準的な電話、コンピュータデータ及び／又はテレメトリを含む。加えて、本システムは住居の加入者に対して現存する明

確なサービスに適応するためのフレキシブルプラットフォームである。

ハイブリッドファイバー・同軸分散ネットワーク11は、中央局又はヘッドエンド32から遠隔に配置された分散ノード18（以下、光分散ノード（ODN）と称する）に電話及びビデオサービスを提供するために光ファイバーフィーダラインを利用する。ODN18から、サービスは同軸ネットワークを経て加入者に分散される。HFC基底通信システム10を利用することにより幾つかの利点が存在する。フィーダにインストールされたファイバーを利用することにより、システム10は100の加入者においてオプトエレクトロニクスの価格をばらまく。分散点から各加入者（「スター」分散アプローチ）に設けられた分離した銅ループを持つ代わりに、システム10は、分散同軸脚部30がサービスのために各家庭及び加入者「タップ」を通るためのバスアプローチを設置する。システム1

0は、非ビデオサービスが、RFスペクトルの専用部分にてより價格的に有効なRFモデム装置を使用して伝送するために変調されることを許容する。最終的に、システム10は、同軸分散リンクが現存するケーブル・レディTVセットを直接駆動することができるので、ビデオサービスが、何ら追加の加入者機器を必要とせずに現存する同軸設備上で担持されることを許容する。

ここで述べるモデムトランスポート・アーキテクチャー、アーキテクチャーの機能性、及びこのようなアーキテクチャーを囲む動作がハイブリッドファイバー・同軸ネットワークよりむしろ分散ネットワークで利用されることは、当業者において明らかである。例えば、機能性は無線システムにおいて実行される。それ故、本発明は添付の請求項に従ってそのようなシステムの使用を企図する。

システム10は、ネットワークインタフェース、同期、DSOG

ルーミング、及び動作、さらに管理、保守及び準備インタフェース(OAM&P)、のような電話トランスポートのための共通の機器機能を備え、さらに、統合サービスユニット100(ISU)のような顧客インタフェース機器へ又はからの情報を担うトランスポートシステムとスイッチングネットワークの間のインタフェースを含むホストデジタル端末12(HDT)を含む。家庭用統合サービスユニット(HISU)68又は多重の居住統合サービスユニットに対向するようなビジネス統合サービスユニットを含む多重ユーザ統合サービスユニット(MISU)66のような、統合サービスユニット(ISU)100は、全ての顧客インタフェース機能及びスイッチされたネットワークへ又はから情報を担うトランスポートシステムへのインタフェースを設置する。本発明のシステムにおいて、HDT12は通常中央局に位置され、ISU100は遠隔の種々の位置に分散されて配置される。HDT12及びISU100は、多対点形態のもとにハイブリッドファイバー・同軸分散ネットワーク11を経て接続される。本発明において、HFC分散ネットワーク11上で情報をトランスポートするために必要とされるモデムの機能性は、HDT12及びISU100の両方におけるインタフェース機器により実行される。このようなモデムの機能性は、直交周波数分割マルチプレックスを利用して実行される。

通信システムは一般的に図1、3及び6に記載される。システム10の基本構成は、ホストデジタル端末(HDT)12、ビデオホスト分散端末(VHDT)34、電話下りトランスミッタ14、電話上りレシーバ16、光分散ノード18を含むハイブリッドファイバー同軸(HFC)分散ネットワーク11、及び遠隔ユニット46に関連した統合サービスユニット66、68(図6にて一般にISU100として示す)である。HDT12は、スイッチングネット

ワーク(一般にトランクライン20で示される)と、電話情報のトランスポートのためのHFC分散ネットワークへのモデムインタフェースとの間の電話インタフェースを提供する。電話下りトランスミッタ14は、図3に示すように、HDT12の同軸RF下り電話情報出力22に対する電気-光学変換を実行し、冗長下り光ファイバーフィーダライン24に送信する。電話上りレシーバ16は冗長上り光ファイバーフィーダライン26上の光信号に対する光学-電気変換を行い、HDT12の同軸RF上り電話情報入力28に電気信号を与える。光分散ノード(ODN)18は、光ファイバーフィーダライン24及び26と同軸分散脚部30の間のインタフェースを提供する。ODN18は同軸分散脚部30上で下りビデオ及び電話を結合する。統合サービスユニットは、同軸分散ネットワークへのモデムインタフェース及び顧客へのサービスインタフェースを提供する。

HDT12及びISU100は、電話トランスポートシステム変調-復調(モデム)機能を設置する。HDT12は、図3に示すように、少なくとも1つのRF-MCCモデム82を含み、各ISU100は図6に示すように、RI-ISUモデム101を含む。MCCモデム82及びISUモデム101は、電話情報をトランスポートするために、HDT12とISU100の間で、DSO+チャネルのような、多重キャリアRF送信技術を使用する。この多重キャリア技術は、システムの帯域幅が多重キャリアに分割された直交周波数分割マルチプレックス(OFDM)に基づき、その各々は情報チャンネルを示す。マルチキャリア変調は、時分割マルチプレックス情報データをとり、これを周波数分割マルチプレックスデータに変換する技術として見ることができる。

多重キャリア上のデータの発生及び変調は、各データチャンネル上

の直交変換を使用してデジタル的に達成される。レシーバは、データを復調するためにサンプル波形のセグメント上で逆変換を実行する。多重キャリアはスペクトル的にオーバーラップする。しかしながら、変換の直交性の結果として、各キャリアのデータは、他のキャリアから無視しうるインタフェース、従って、トランスポートされたデータ信号の間で減小するインタフェース、で復調される。マルチキャリア送信は、特に多対点システムの上り通信において必要とする送信帯域の効率的な利用を得る。マルチキャリア変調は、また多重マルチプレックスデータストリームをアクセスするための効率的な手段を提供し、帯域のいかなる部分においてもマルチプレックス情報を抽出されるためにアクセスされることを許容し、比較的長いシンボル時間を持つ結果としてインパルスノイズを除いた多くのノイズを提供し、そして、グレードの下げられたキャリアを明らかにすることにより狭帯域の干渉を除去し、データ送信のキャリアの使用を禁止する有効な手段を提供する（このようなチャンネル監視及び保護は以下に詳しく説明される）。本質的に、電話トランスポートシステムは、干渉及び劣った性能を持つキャリアの使用を無力にすることができ、送信品質目標を持つキャリアのみを使用する。

さらに、ODN 18は下りビデオを同軸分散脚部30上の送信のための電話情報と結合する。通常、トランクライン20で示される現存するビデオサービスからのビデオ情報はヘッドエンド32にて受信され処理される。ヘッドエンド32又は中央局は、ビデオデータインタフェースのためのビデオホスト分散端子34（VHDT）を含む。VHDT34は、分散ネットワーク11のODN18を経て遠隔ユニット46へビデオ情報を通信するために関係した光トランスミッタを持つ。

図3及び4に示すHDT12の電話トランスミッタ14は、送信

される電話データを保護するために下り電話送信のための2つのトランスミッタを含む。これらのトランスミッタは従来のものであり、比較的高価でない狭帯域レーザトランスミッタである。1つのトランスミッタは、もし他のものが本来的に機能しているならばスタンバイしている。動作中のトランスミッタにおいて障害を検出すると、送信はスタンバイトランスミッタに切り換わる。反対に、VH

D T 3 4 のトランスミッタは、広帯域アナログ D F B レーザトランスミッタなので H D T 1 2 のトランスミッタと比較して比較的高価である。それ故、ビデオ情報の保護、電話データでない非本質的サービスは保護されずに残される。ビデオデータ送信から電話データ送信を分割することにより、電話データのみの保護が達成できる。ビデオデータ情報及び電話データが、高価な広帯域アナログレーザにより1つの光ファイバー上で送信されたならば、経済は電話サービスの保護が不可能であることを指図する。それ故このような送信の分離は重要である。

さらに図1を参照すると、ビデオ情報は、下りで光ファイバーライン40を経てスプリッタ38へ光学的に送信され、スプリッタ38は、複数の光ファイバーライン42上で複数の分散ノード18へ送信するための光ビデオ信号を分離する。H D T 1 2 と関連した電話トランスミッタ14は光ファイバーフィーダライン42を経て光分散ノード18へ光電話信号を送信する。光分散ノード18は、ハイブリッドファイバー同軸(H F C)分散ネットワーク11の同軸分散部分を経て複数の遠隔ユニット46への電気的な出力として送信するために、光ビデオ信号及び光電話信号を変換する。電気的な下りビデオ及び電話信号は、H F C ネットワーク11の同軸分散部分の複数の同軸脚部30及び同軸タップ44を経てI S U へ分散される。

遠隔ユニット46は、図6に示すように、I S U 1 0 0 と関連しており、I S U 1 0 0 は、例えば電話及びデータ端子からの電話情報を含む上り電気的データ信号を送信する手段を含み、さらに、以下に説明するように、セットトップボックス45からセットトップ情報を送信する手段を含む。上り電気的データ信号は、複数のI S U 1 0 0 によりH F C 分散ネットワーク11の同軸部分を経て接続された光分散ノード18に提供される。光分散ノード18は、光ファイバーフィーダライン26上でヘッドエンド32に送信するために上り電気的データ信号を上り光データ信号に変換する。

図2は、ヘッドエンド32から光分散ノード18へ光ビデオ信号及び光電話信号の送信を提供する他の実施形態を示し、この実施形態のH D T 1 2 及びV H D T 3 4 は同じ光トランスミッタ及び同じ光ファイバーフィーダライン36を利用

する。H D T 1 2 及び V H D T 3 4 からの信号は結合され、光学的にヘッドエンド 3 2 からスプリッタ 3 8 に送信される。結合された信号はスプリッタ 3 8 により分離され、4 つのスプリット信号は、同軸分散脚部 3 0 及び同軸タップ 4 4 により遠隔ユニットへの分散のために光分散ノード 1 8 に提供される。O D N 1 8 からの戻り光電話信号はヘッドエンドへの供給のためにスプリッタ 3 8 にて結合される。しかしながら、上述したように、利用される光トランスミッタは、その広帯域能力により比較的高価であり、本質的な電話サービスの保護を与えることができる蓋然性を少なくする。

当業者が認識するように、ファイバーフィーダライン 2 4 及び 2 6 は、図 1 に示すように、2 つは下り電話トランスミッタ 1 4 からの下り送信で、2 つは上り電話レシーバ 1 6 への上り送信のための 4 つのファイバーを含む。指向性カプラーが使用されると、このようなファイバーの数は半分にカットされる。さらに、保護トランス

ミッタ及び利用されるファイバーの数は、当業者にて知られるように変化し、いずれかリストされた数は添付の請求項に記載のように本発明に限定されない。

本発明はより詳細に記載される。記載の第 1 の部分は基本的にビデオトランスポートを扱う。残りの記載は基本的に電話トランスポートを扱う。

ビデオトランスポート

通信システム 1 0 はトランクライン 2 0 を経てビデオ及び電話サービスプロバイダからビデオ及び電話情報を受けるヘッドエンド 3 2 を含む。ヘッドエンド 3 2 は複数の H D T 1 2 及び V H D T 3 4 を含む。H D T 1 2 は、電話サービスプロバイダへ又はから T 1 . I S D N への電話情報、又は他のデータサービス情報を通信するためのネットワークインタフェースを含み、このような通信はトランクライン 2 0 で示される。V H D T 3 4 は、例えばケーブル T V 情報のようなビデオ情報を通信するビデオネットワークインタフェースと、ビデオサービスプロバイダへ又はからの加入者の対話データを含み、このような通信はトランクライン 2 0 で示される。

V H D T 3 4 はビデオ光ファイバーライン 4 を経てスプリッタ 3 8 へ下り光信

号を送信する。受動光スプリッタ38は効率的に下り高帯域幅光ビデオ信号の4つのコピーを作る。コピーされた下り光ビデオ信号は、対応して接続された光分散ノード18に分散される。当業者においては下りビデオ信号の4つのコピーが作られるが、コピーの如何なる数も適当なスプリッタにより作られることを容易に認識し、本発明は特定の数に限定されない。

スプリッタは、高価な広帯域の光-電気変換ハードウェアを採用することなく広帯域光信号を分離する受動手段である。光信号スプリッタは当業者には共通に知られており、例えばG o u l d社のよ

うな、多くの光ファイバーコンポーネント製造者から入手できる。他の場合として、能動スプリッタも利用される。さらに、カスケードチェーンの受動又は能動スプリッタが、光分散ノードの追加した数に適用するために複写した光信号の数を掛け、それにより単一のヘッドエンドにてサービス可能な遠隔ユニットを増大する。このような変形例は添付の請求項に記載のように本発明に従って企図される。

V H D T 3 4 は、中央局ケーブルTVヘッドエンド又は遠隔局及び112NTSCチャンネルまでの放送にて配置される。V H D T 3 4 は、現在は譲受人の補助としてのA m e r i c a n L i g h t w a v e S y s t e m 社から入手可能なL i t e A M P TMのような伝送システムを含む。ビデオ信号は、信号が受信される(即ち、光送信がRFビデオ信号で変調されるテラヘルツキャリアである)同じ周波数で1300ナノメートルレーザー源の振幅変調により光学的に送信される。下りビデオ送信帯域幅は約54-725MHzである。受信したビデオ信号の周波数としてビデオ信号の光送信のために同じ周波数を使用することの利点は、減少した変換費用とともに高帯域幅送信を提供することである。この同じ周波数送信アプローチは、下りの変調が光-電気変換又はフォトダイオードによる比例変換及び恐らく増幅を必要とし、周波数変換でないことを意味する。さらに帯域幅の減少及び分解能の低損失のサンプルデータはない。

光分散ノード18は、図5に示すように、光ファイバーフィーダライン42上でスプリッタ38からスプリット下り光ビデオ信号を受ける。下り光ビデオ信号

は光分散ノード18の下りビデオレシーバ400に与えられる。利用される光ビデオレシーバ400は、American Lightwave System社から入手可

能なLite Amp™ プロダクトラインのものである。フォトダイオードを利用した比例して変換されたビデオレシーバ400から変換された信号は、下り電話レシーバ402からの変換された電話信号にそってブリッジャー (bridge) 増幅器403に与えられる。ブリッジャー増幅器403は、同時にダイプレックスフィルタ406に4つの下り電気的な電話及びビデオ信号を与え、ダイプレックスフィルタ406は、2つの異なる周波数帯域幅の信号が上り及び下り送信に利用される時に、送信及び受信機能を分離することにより全二重動作を許容する。ビデオ又は下り電話信号についてODN18で実行される周波数変換はなく、信号は、ODN18で受信されたと同じ周波数帯域でHFC分散ネットワーク11の同軸部分を介して遠隔ユニットへ、ODNを経て送られる。

ODN18が下り光ビデオ信号を受信し、信号が下り電気的ビデオ信号に変換された後に、ODN18の4つの出力は、下り電気的ビデオ信号を遠隔ユニット46に送信するために、HFC分散ネットワーク11の同軸部分の4つの同軸脚部30に与えられる。電気的ビデオ信号に対するこのような送信は54-725 MHz帯域幅で生じる。各ODN18は複数の同軸脚部30上の送信のために提供され、出力の如何なる数も添付の請求項に記載のように本発明に従って企図される。

図1に示すように、各同軸ケーブル脚部30は、複数の同軸タップ44を経て下り電気的ビデオ及び電話信号とともに重要な数の遠隔ユニット46を提供することができる。同軸タップは当業者にて共通に知られており、電気信号の受動双方向ピックアップとして作用する。各同軸ケーブル脚部30はシリーズに接続された幾つかの同軸タップ44を有する。さらにHFC分散ネットワーク11の同軸部分は拡張するために幾つかの数の増幅器を使用し、距離データは

このような分散ネットワーク11上の同軸部分上で送られる。

下りビデオ信号は同軸タップ44から遠隔ユニット46に提供される。同軸タップ44からのビデオ信号は、図6にて通常ISU100のブロック図で示されるHISU68に提供される。ISU100はタップ44から下り電氣的ビデオ及び電話信号で提供され、ダイプレックス104に与えられる。下り電氣的ビデオ及び電話信号はダイプレックスフィルタ104を経てイングレスフィルタ105及びISUモデム101に送られる。下りビデオ信号は任意のセットトップボックス45を経てビデオ機器に送られる。ダイプレックスフィルタ104からISUモデム101に与えられる下り電氣的な電話信号は、以下に詳しく記載のように処理される。

イングレスフィルタ105は、電話やコンピュータ端子のような他のユーザ機器に提供されるものとは反対に、ビデオ機器に与えられる信号の干渉に対抗した保護とともに遠隔ユニット46に提供する。イングレスフィルタ105はビデオ信号を通すが、しかしビデオ機器で利用されない周波数は阻止する。ビデオ機器により使用されないこれらの周波数を阻止することにより、少なくとも同じ遠隔ユニットへネットワークによる他のサービスとともに干渉する浮遊信号は除去される。

セットトップボックス45は遠隔ユニット46における任意の要素である。セットトップボックス45からの対話ビデオデータは、約5乃至40MHzの帯域幅で比較的低い周波数においてビデオサービスプロバイダにより提供される付加的な分離RFモデムにより送信される。このような周波数は、上りと下り電話データ及び下りビデオの伝送に使用される1つではない。

MISU66に対して同軸タップ44からの分離同軸ラインは、同軸タップ44からセットトップボックス45へビデオ信号の送信

を提供し、ビデオ機器47へ下りビデオ信号を提供するために利用される。イングレスフィルタ105は、図6において、ダッシュで表示されるようにMISU66の一部ではない。

VHDT34の他の実施形態は、ビデオ信号の周波数でシフトするために他の変調及び混合方法及び技術を採用し、さらにコード化されたフォーマットで情報

を送信するための他のエンコード方法を採用する。デジタルビデオデータの送信に加えて、アナログビデオデータを送信する技術及び方法は当業者にて知られており、添付の請求項に記載のように本発明の精神及び範囲に従って企図される。

電話トランスポート

図3において、電話情報及びISU動作及びMCCモデム82によりキャリア上で変調された制御データ(以下、制御データ)は、同軸ライン22を経てHDT12及び電話下りトランスミッタ14の間で送信される。電話情報及びISU100によりキャリア上で変調された制御データは電話上りレシーバ16にて受信され同軸ケーブルライン28を経てMCCモデム82に通信される。電話下りトランスミッタ14及び電話上りレシーバ16は、光ファイバーフィーダライン24及び26を経て対応する光分散ノード18へ又はから電話情報及び制御データを各々送信し受信する。制御データは、システム11の電話サービス及びHDT12とISU100の間の電話情報のトランスポートを提供するために必要な他の制御データを提供するための、全ての動作、管理、保守、及び準備(OAM & P)を含む。

HDT12のブロック図は図3に示される。HDT12は、以下のモジュール、8つのDS1ユニット(DSUIU)(7つのカッド(quad)DS1ユニットと1つの保護ユニット50)、1つの保護スイッチ&テスト変換ユニット52(PSTU)、2つのク

ロック&タイムスロット・インタチエンジユニット54(CTSU)(1つは現用で1つは予備/保護ユニット)、6つのコアックスマスタユニット56(CX MU)(3つは現用で3つは予備/保護ユニット)、及び2つの電源供給ユニット60(PWRU)(2つは中央局供給から適切なHDT電圧を供給する負荷共用ユニット)である。

HDT12は、通信システム10の電話トランスポートの全ての共通機器機能を備える。HDT12は通常は中央局に配置され、ローカルデジタルスイッチ又はデジタルネットワーク要素機器に直接インタフェースする。HDTは全ての電話情報に対してネットワークインタフェース62を提供する。各HDTは、ネッ

トワーク62において2乃至28DSX-1入力に適合し、これは672DSOチャンネルの最大を示す。

HDT12は、またシステム11における電話トランスポートに対して全ての同期を提供する。HDT12は、外部タイミング、ラインタイミング、内部タイミング、の3つの同期モードのいずれかで動作する。外部タイミングは、HDT12が配置された中央局から発生される供給基準の構築された統合タイミングに同期することを引用する。ラインタイミングは、通常ローカルデジタルスイッチから導かれたDSX-1信号からのリカバークロックに同期する。内部タイミングは、HDTが如何なる有効基準入力の不在にてそれ自身の同期を維持するフリーラン又はホールドオーバー動作である。

HDT12は、1/4-DSOグルーミング・ケイパビリティを提供し、4096×4096フルアクセスと非ブロッキング-1/4-DSO(16kbps)クロスコネクト・ケイパビリティを提供する。これは、DSO及び1/4-DSO(ISDN“D”チャ

ネル)が、DSX-1ネットワークインタフェース62におけるいずれかのタイムスロットから、いずれかのISU100によりサービスされたいずれかの顧客に対して、ルート化されることを許容する。

HDT12はMCCモデム82を含むHFC分散ネットワーク11上の電話トランスポートに要求されるRFモデム機能性を提供する。HDT12はHFC分散ネットワーク11にモデムインタフェースを提供するために3つの現用CXMU56まで適合し、各現用CXMU56に対して1対1の保護を提供する。

HDT12は、多対点通信システム11の多くのISUの制御及び通信を含む電話トランスポートシステムを統合する。各HDT12モジュールは機能を実行する。DS1Uモジュール48はデジタルネットワーク及びDSX-1終端にインタフェースを提供する。PSTU52は、故障したDS1Uモジュール48に対して保護DS1U50を切り換えることにより、DS1U機器の保護を提供する。CTS U54は、1/4-DSOタイムスロットグルーミング・ケイパビリティ及び全システム同期機能を提供する。CTS U54は、またシステムにおけ

る全ての呼処理を都合する。CXMU56は、以下に詳しく記載するように、HFC分散ネットワーク11上のOFDM電話トランスポートに対してモデム機能とインタフェースを提供し、SCNU58は、電話トランスポートに対して全てのOAM&P機能を提供する通信システムの動作を監視する。準備のための要求の殆どの処理はSCNU58で実行される。

下り電話トランスミッタ

下り電話トランスミッタ14は、図4に示すように、電話情報及び制御データを担うHDT12の現用CXMU56からの同軸RF出力22をとり、出力22を下り電話送信信号に結合する。光送信

で要求される電気-光変換ロジックは、より价格的に有効なトランスポート解法を提供するためにHDT12よりもむしろ自立形下り電話トランスミッタ14においてインプリメントされる。個々のコンポーネントにこの機能を置くことにより、この機能の費用は、HDT12の各CXMU56にて繰り返される必要はない。これはCXMU56の機能のコストを減じ、CXMU56がファイバーの代わりに同軸上で送信し受信することを許容する。下り電話トランスミッタ14は、また冗長下りファイバーフィーダライン24上でODN18への送信を提供する。

下り電話トランスミッタ14は、恐らく100フィート又はそれ以下の距離内でHDT12と共に配置される。下り電話トランスミッタ14は、各々6MHz周波数帯域で現用CXMU56から同軸RF出力を受け、カプラー25にてそれらを単一のRF信号に結合する。各6MHz周波数帯域は、当業者で知られるようにガード帯域により分離される。下り電話情報は約725-800周波数帯域で送信される。電話トランスミッタ14は1対2スプリッタ(図示せず)を経て結合された信号を通し、それにより冗長下り電気信号を生じる。2つの冗長信号は、各々電気-光変換のために冗長レーザトランスミッタ501に引き渡され、冗長信号は、下り電話トランスミッタ14の出力が2つのフィーダライン24で各々が同じ変調された信号を持つように光出力を変調する。これは本発明のシステムの下り電話部分に対する保護を提供する。電話トランスミッタ14における

両方のヘブリーペロー (Fabry-Perot) レーザは全ての時間でアクティブである。全ての保護機能は光送信の受信端 (ODN 18 に配置される) で提供され、2つのレシーバの内の1つは「アクティブ」として選択され、従って、電話トランスミッタ 14 は保護スイッチングケイバビリティを要求しない。

上り電話レシーバ

上り電話レシーバ 16 は、ODN 18 からの上り光フィーダライン 26 上で上り光電話信号の光-電気変換を実行する。上り電話レシーバ 16 は、通常中央局において HDT 12 とともに配置され、HDT 12 へ電氣的同軸出力と、ビデオセットトップコントローラ (図示せず) に与えられる同軸出力 23 を提供する。上り電話情報は、上り電話レシーバ 16 から HDT 12 の現用 CXMU 56 へ同軸ライン 28 を経てルート化される。HDT 12 と上り電話レシーバ 16 の間の同軸リンク 28 は好適には距離 100 フィート又はそれ以下に限定され、イントラオフィスリンクである。ビデオセットトップコントローラ情報は、ビデオトランスポート部分で記載したように、5乃至40 MHz の RF スペクトルの帯域に配置され、この帯域は上り電話情報にそって送信され、上り電話トランスポートに利用されない。

上り電話レシーバ 16 は、デュアル上り光ファイバーライン 26 に対してデュアルレシーバ 502 を持つ。これらのフィーダライン 26 は、電話情報と制御データとビデオセットトップボックス情報を含む ODN 18 からの冗長信号を担う。上り電話レシーバ 16 は、ODN からの上りフィーダライン 26 上で自動的な保護切り換えを実行する。保護ロジックにより「アクティブ」として選択されたレシーバ 502 は HDT 12 を駆動する同軸出力 28 に供給するために分離され、出力 23 はセットトップコントローラ (図示せず) に提供される。

光分散ノード

図 5 に示すように、ODN 18 は、HDT 12 からの光フィーダライン 24 および 26 と、遠隔のユニット 30 へ通ずる HFC 分散ネットワーク 11 の同軸部分との間のインタフェースを提供する。

このように、ODN18は、基本的に光-電気変換装置であって且つ電気-光変換装置である。ODN18から任意のISUのコアックスまでの最も長い距離は、好ましくは約6kmであり、結合されている状態の光フィーダライン/同軸ドロップの長さの最高値は、好ましくは約20kmである。ODN18の光フィーダライン側は、6本のファイバでもって終結する。ただし、これらのファイバの数は可変である。上記の6本のファイバは、下りビデオフィーダライン42（ビデオスプリッタ38から通ずる単一のファイバ）と、下り電話フィーダライン24（下り電話トランスミッタ14から通ずるフィーダライン）と、下り電話保護用フィーダライン24（下り電話トランスミッタ14から通ずるフィーダライン）と、上り電話フィーダライン26（上り電話レシーバ16へ通ずるフィーダライン）と、上り電話保護用フィーダライン26（上り電話トランスミッタ16へ通ずるフィーダライン）と、スペアファイバ（図示されていない）とによって構成される。ODN18は、下り電話トランスミッタから通ずる受信用の光フィーダライン24上での保護を目的とした切り換え機能を提供する。また一方で、ODN18は、上り電話レシーバへ通ずる上り光フィーダライン26上で冗長性の送信を提供する。ここでは、上り光フィーダライン上での保護は、上り電話レシーバ16にて制御される。ODN18の同軸分散側において、このODN18は、最大4つの同軸脚部30でもって終結する。

下り方向において、ODN18は、光の下り電話信号を電気信号に変換する下り電話レシーバ402を有している。さらに、ODN18は、下り電話レシーバ402からの電気信号と、下りビデオレシーバ400からの変換後の下りビデオ信号とを結合させるブリッジャー増幅器403を有している。ここで、下りビデオレシーバ4

00は、VHDT34から通ずるODN18にて終結する。下りビデオレシーバ400にて結合した広帯域の電話/ビデオ信号は、さらに、下り伝送用に割当てられたスペクトル内で転送される。例えば、このスペクトルは、HFCの分散ネットワークにおける同軸部分の4つの脚部の各々において725~800MHzの帯域を有する。このようにして、上記の電氣的な電話信号およびビデオ信号は

、4つの同軸部分の脚部を通過して複数のISU100に伝送される。さらに、ブリッジャー増幅器403は、4種の下りの電気的な電話信号およびビデオ信号を複数のダイプレックスフィルタ406にそれぞれ印加する。2つの異なる周波数帯域内で、それぞれ上り伝送用および下り伝送用として信号が使用される場合、上記のダイプレックスフィルタ406は、送信機能および受信機能を分離することによって完全な二重動作を可能にする。ODN18にて受信したときと同じ周波数帯域において、電話信号およびビデオ信号が、ODN18を通過した後にHFCの分散ネットワーク11の同軸部分を介して遠隔のユニット46に達したときには、ODN18にて周波数変換を実行することはない。図1に示すように、各々の同軸脚部30は、複数の同軸タップ44を介して、相当な数の遠隔のユニット46に対し下りの電気的な電話信号およびビデオ信号を供給することができる。当業者にとって周知の同軸タップは、複数種の電気信号を両方向に取り込む動作をする受動素子の役目を果たす。各々の同軸脚部30はまた、直列に接続された多数の同軸タップを有することも可能である。さらに、HFCの分散ネットワーク11の同軸部分は、データがシステム10の同軸部分を通過して送られる距離を伸ばすために、任意の数の増幅器を使用することが可能である。下りの電気的な電話信号およびビデオ信号は、さらに、一つのISU(図6)に供給される。より具体的にいえば、このIS

Uは、図1に示すようなHISU68またはMISU66である。

上り方向において、電話情報およびセットトップボックス情報は、5MHzから40MHzまでのRFスペクトル領域において、4つの同軸脚部30を通過した後にODN18内のダイプレックスフィルタ406により受信される。ODN18は、4つの同軸脚部30中の最高3つの同軸脚部に設けられた選択的な周波数シフタ64を有することが可能である。上記ODN18はまた、もし使用する予定があるならば、一つの同軸脚部上の上りスペクトルを他の3つの同軸脚部と混合する前に、上記の一つの同軸脚部上の上りスペクトルと、この上りスペクトルより高い周波数とを混合することも可能である。周波数シフタ64は、上りスペクトルを50MHzの任意の倍数の値に推移させるように設計される。例えば

、周波数シフト64は、RFスペクトルの5MHz～40MHzの部分にある上り情報と、次の周波数領域のいずれかとを混合するように設定される。すなわち、50MHz～100MHz、100MHz～150MHz、または150MHz～200MHzの周波数領域である。このことによって、上り情報がODN18内で結合したときでも、任意の同軸脚部30が他の脚部と何ら競合することなく、RFスペクトル内の他の脚部と同じ部分を使用することが可能になる。上記のような周波数シフト64の設定動作は、一つの同軸脚部30上で選択可能である。ODN18はまた、結合器408を有している。この結合器408は、全ての同軸脚部30（同軸脚部30は、周波数シフトがなされているかもしれないし、あるいは、まだなされているかもしれない）からの上りの電気的な電話情報およびセットトップボックス情報を結合させることによって、4つの同軸脚部30の各々に存在する全ての上り情報を含む一つの複合の上り信号を生成するためのものである。このような複合の電気的な上り信号は、

受動的に1：2分割により分割される。さらに、各々の上り信号は、上りのファブリーペロー式レーザ送信器に供給される。さらに、このファブリーペロー式レーザ送信器は、上り電話レシーバ16に上り信号を伝送するために、対応する上りファイバフィーダライン26を駆動する。

もし、上りの電話情報およびセットトップボックス情報が、ODN18においてより高い周波数領域に推移するならば、上り電話レシーバ16は、ODN18にて生ずる高い周波数領域へのシフト量に従って信号をより低い周波数領域に推移させるための周波数シフト31を備えている。カプラー33は、さらに、より低い周波数領域に推移した全ての信号を結合させることによって、この結合した状態の信号をHDT12に印加するようにしている。ODN18にて信号がより高い周波数領域に推移する場合にのみ、上記のような信号のより低い周波数領域へのシフトおよび信号の結合が用いられる。

統合サービスユニット (ISU)

図1に示すように、HISU68およびMISU66のような複数のISU100は、HFCの分散ネットワーク11と、遠隔のユニット46に対する顧客サ

サービスとの間のインタフェースを提供する。ここでは、特定の顧客にサービスを提供するような2つのタイプのISUが例示されている。マルチユーザ統合サービスユニット66(MISU)は、マルチ住宅統合サービスユニットかまたはビジネス統合サービスユニットであることも可能である。このマルチ住宅統合サービスユニットは、居住環境と事業所の環境とを組み合わせられた環境に対して使用することも可能である。例えば、多数の居住者が住むビルディングや、複数の小さな事業所や、一群の住居等の環境が考えられる。これらの環境に関わる顧客は、わかりやすく

且つ経験豊富な電話サービス(POTS)や、データサービスや、DSIサービスや、標準のTR-57サービスのような複数種のサービスを要求する。複数のビジネス統合サービスユニットは、事業所の環境のサービスを実行するように設計される。これらのビジネス統合サービスユニットは、データサービスや、ISDNや、DSIサービスや、ビデオ相談等のような比較的高い周波数帯域のサービスをも要求することがあり得る。住居統合サービスユニット68(HISU)は、一人の居住者が住むビルディングのような居住環境や、意図されたサービスが、POTSと、基本的な等級である統合デジタルサービスネットワーク(ISDN)であるような2階建てアパートのような居住環境に対し使用される。本発明に関する限り、マルチ住宅統合サービスユニットと事業所統合サービスユニットとは同じような機能を有しているので、ここでは説明を簡単にするために、上記のISUに関する記述をHISUとMISUに限定することとする。

全てのISU100は、RFモデムの機能を遂行し、一般的には図6のISU100により示される。このISU100は、ISUモデム101と、コアックススレーブコントローラユニット(CXSU)102と、顧客サービスインタフェースを提供するチャンネルユニット103と、ダイプレックスフィルタ/タップ104とを有している。下り方向において、下りの電気的な電話信号およびビデオ信号は、ダイプレックスフィルタ/タップ104に印加される。HISUが使用される場合、このダイプレックスフィルタ/タップ104は、電話情報をISUモデム101に渡すと共に、イングレスフィルタ105を介してビデオ情報を

ビデオ機器に渡す。ISU100がMISU66である場合、ビデオ情報はダイプレックスフィルタにより取り除かれる。ISUモデム101は、MCCモデム

82に対応する一つのモデムを利用して下り電話情報を復調する。ここで、MCCモデム82は、HDT12の直交マルチキャリアでもって上記の下り電話情報を復調するために用いられるものである。ISU100はまた、一時的に設定された6MHzの周波数帯域において、同軸分散脚部30からの下り電話情報を復調する。ISUモデム101内のタイミング生成107は、CXSU102に対し基準となるクロックを提供する。ここで、CXSU102は、各種の処理を規定すると共に、ISUモデム101による受信および送信を制御する。ISUモデム101から復調されたデータは、提供されるサービスに応じて、利用可能なチャンネルユニット103に送られる。例えば、チャンネルユニット103は、POTS、DSIサービス、ISDN、およびその他のデータサービス等を実行するためのラインカードを備えることが可能である。各々のISU100は、6MHzの周波数帯域にて利用可能な全てのチャンネルの中で、HDT12内の複数のCXMUの一つに対応する固定されたサブセットに対するアクセスを実行する。このようにしてアクセスがなされたチャンネル中のサブセットは、ISU100の種類に応じて変化する。MISU66は、6MHzの周波数帯域において、多数のDSOチャンネルに対するアクセスを実行することも可能である。また一方で、HISU68は、2～3のDSOチャンネルに対してのみアクセスを実行することができる。

チャンネルユニット103は、電話情報を提供すると共に、CXSU102へ送られるデータを制御する。ここで、CXSU102は、上記データをISUモデム101に供給すると共に、一時的に設定された6MHzの周波数帯域において、上記の電話データおよび制御データを変調するために、ISUモデム101に接続された同軸分散脚部30上で上記ISUモデム101を制御する。ISUモ

デム101によりHDT12への送信を行うために一時的に設定された上りの6MHzの周波数帯域は、HDT12内のCXMU56による送信に使用される複

数の下りの6MHzの周波数帯域の一つに対応する。

CXSU102は、ISUモデム101から復調されたデータを、利用可能なチャンネルユニットに印加するものである。さらに、このCXSU102は、ISUモデム101から受信された下り10ビットのDSO+パケット上で、データの完全性のチェックを実行する。下り10ビットのDSO+パケットの各々は、後述するように、パリティビットまたはデータインテグリティビットを含む。CXSU102はまた、下り10ビットのDSO+パケットの各々を受信する度に、下り10ビットのDSO+チャンネルの各々のパリティをチェックするであろう。さらに、チャンネルユニット103から受信した各々の上りDSO+のパリティが算出される。さらにまた、上りデータのエラーをHDT12によりデコードして識別するために、各々の上りDSO+の10番目のビットとしてパリティビットが挿入される。もし、CXSU102が受信した下り10ビットのDSO+チャンネルのパリティをチェックしたときに、CXSU102によりエラーが検出されたならば、下り方向にパリティエラーが生じたことをHDT12に知らせるために、対応する上りチャンネルのパリティビットが意図的に逆転される。それ故、上りパリティビットは、下りDSO+チャンネルと、この下りDSO+チャンネルに対応する上りDSO+チャンネルにてエラーが生じたことを示すことになる。上記のようなパリティビットを生成するためのプロセスの例が、「1対多の動作監視および障害分離システム」というタイトルであって譲受人に譲渡された米国特許出願（出願番号08/074,913）にて記述されている。このような上りパリティビット

は、さらに後述するように、チャンネル監視に利用される。当業者にとって明らかなことではあるが、パリティチェックおよびパリティ生成は、少なくとも一部において、ISU内の他の構成要素、または、チャンネルユニット等の上記構成要素に関連する別の構成要素により実行される。

各々のISU100は、エラーが生じた下り送信の同期を復帰させ、ISU100のデータ伝送に必要な全てのクロックを生成し、さらに、これらのクロックをそれぞれ関連するHDTタイミングにロックする。ISU100はまた、顧客

のライン起動状態およびライン休止状態を検出するために必要な機能の呼び出し処理を実行し、且つ、これらの状態の表示をHDT12に伝達する。さらに、ISU100は、HDT12からの制御データを終結し、且つ、受信する。さらにまた、ISU100は、HDT12から受信された制御データを処理する。この制御データの処理には、通信システム10におけるダイナミックチャネルの割当てを調整するためのメッセージが含まれている。最終的に、ISU100は、HFCの分散ネットワーク11にて受信されるパワー信号に基づいてISU動作電圧を生成する。このようなパワー信号として、ダイプレックスフィルタ/タップ104から得られるパワー信号109が例示されている。

HDTにおけるデータパス

ホストデジタルターミナル(HDT)12におけるデータパスに関する詳細な検討結果を次に述べることとする。図3に示すように、ネットワークインタフェース62におけるネットワーク装置と、下り電話トランスミッタ14との間のデータパスは、下り方向において、それぞれ、HDT12内のDSIU48、CTSU54およびCXMU56のモジュールを通過して進んでいく。HDT12内

の各々のDSIU48は、ネットワークから4つのDSIを受け取り、このようにして受け取った情報をフォーマット化することによって、24チャンネルからなる2.56Mbpsの4つの修正されたDSO信号のデータの流れを生成する。このようなデータの流れは、CTSU入力76と呼ばれるものである。CTSU入力の各々のDSOは、マルチフレームのタイミング信号の情報と制御/ステータスメッセージ(図7A)を伝達する9番目のビットを付加することによって修正される。9番目のビット信号(NBS)は、各々のフレームに対し更新され、24フレーム毎に繰り返すようなパターンを伝達する。このパターンは、ネットワークからの各々64kbpsのDSOを、72kbpsのDSO+にマッピングする。このようにして、各々のDSIにて利用可能な24個のDSOチャンネルが、全体の情報と共にフォーマット化され、4つのCTSU入力の各々にて24チャンネルのDSO+チャンネルが生成される。

9番目のビット信号(NBS)は、マルチフレームのタイミング、帯域外であ

ることを知らせるための信号ビット、種々雑多な状態、および、DSIUとチャネルユニットとの間の各々のDSOに関連した制御情報を伝達するために考え出されたメカニズムである。上記9番目のビット信号の主な機能は、上記の信号ビットをチャネルユニット103に伝達し、このチャネルユニット103に対しマルチフレームクロックを供給することである。このような機能によって、マルチフレーム内の正しいフレームのDSOに上りビットの信号を挿入することができるようにしている。下りDSOは、同じマルチフレーム位相を共有しないようなDSIからやって来るので、各々のDSOは、DSIの開始に関連した信号フレームを示すマルチフレームクロックまたはマーカを持たなければならない。NBSは、このようなマルチフレームクロックまたはマーカを持つ能力

を提供する。9番目のビット信号は、通信システム11のOFDMモデムのトランスポートに対しては透明である。

単一のHDT12には、7つのアクティブDSIU48と、1つの保護用のDSIUモジュール50とを含むような最大8つのDSIU48が設けられる。この場合、DSIUとCTS U54との間に32個のCTS U入力が接続されるけれども、最大28個のCTS U入力が、一度にトラフィックを行う際に利用できる。残りの4つのCTS U入力は、保護用DSIUに関連しているか、または、故障したDSIUに関連している。PSTUは、故障したDSIUを保護用のDSIU50に切替えるための切替制御の機能を有している。

各々のCTS U入力は、最大32個の10ビットチャネルを伝達することが可能である。最初の24チャネルはDSO+を伝達し、残りの帯域は使用されない。各々のCTS U入力76は、2.56Mbpsにてクロック設定がなされ、8kHzの内部フレーム信号に同期する(図7C)。この2.56Mbpsの値は、125 μ secにつき320ビットのフレーム周期に対応する。これらの320ビットに対しては、図7Aに示すようなフレーム設定がなされる。フレームの開始時における14ビットのギャップビット72は、2番目のビット位置における単一のアクティブパルスのみを伝達し、残りの13ビットは、使用されない。288ビットの中で、最初の216ビットは、通常、24個のDSO+チャネル

を伝達する。この場合、各々のDSO+チャンネルは、72 kbps (8 kHzのフレーム毎に9ビット)の帯域を有している。残りの72ビットは、付加的なDSO+ペイロードチャンネルとして取っておかれる。フレームの最後の8ビット74は、使用されないキャップビットである。

HDT12のクロックおよびタイムスロット交換ユニット54 (CTS U)は、最大28個のアクティブCTS U入力データの流れ76からの情報を受け取り、これらのCTS U入力データの流れ76と、最大24個の32チャンネルからなる2.56 Mbpsの出力データの流れ78との切替接続を行う。ここで、出力データの流れ78は、HDT12のコアックスマスタユニット (CXMU) 56に入力される。CTS U 54とCXMU 56との間のデータの流のフォーマットは、CTS U出力とよばれる。各々のCTS U出力はまた、CTS Uのような最大32個の10ビットのチャンネルを伝達する。最初の28個のチャンネルは、信号を伝達するが、残りの帯域は使用されない。各々のCTS U出力は、2.56 Mbpsにてクロック設定がなされ、HDT12の8 kHzの内部フレーム信号に同期する (図7C)。この2.56 Mbpsの値は、125 μ secにつき320ビットのフレーム周期に対応する。このようなフレーム構成は、前述したようなCTS U入力の構成と同じである。

HDT12は、1/4 DSOパケット (16 kbps)を時間的および空間的に操作する機能を備えている。このような機能は、CTS U 54の一部であるタイムスロット交換ロジックにより遂行される。この場合、CTS Uは、4096 \times 4096の1/4 DSO切替接続機能を遂行する。ただし、必ずしも全てのタイムスロットが使用されるわけではない。通常の動作においては、CTS U 54は、各々が24 DSO+からなる28個のCTS U入力として配置された最大672個の下りDSO+パケット (すなわち、最大2688個の1/4 DSOパケット)を組み合わせる再配置することによって、各々が32のDSO+からなる24個のCTS U入力として配置された最大720個の下りDSO+パケット (すなわち、最大2880個の1/4 DSOパケット)が生成される。

システムは、ネットワークインタフェースにおいて、最大672のDSO+パケットのスループットを有している。ただし、CTS U出力の全ての帯域が使用できるとは限らない。もし、CTS U内の“CTS U出力”側にて672以上のチャンネルが割当てられるならば、このことは、CTS U出力が集中的に利用されたことを意味する。

アクティブCTS U54からの8つのアクティブCTS U出力78を受信するために、各々のCXMU56が接続される。8つのCTS U出力は、2.56Mbpsにてクロック設定がなされ、各々のCTS U出力は、前述したような32のDSO+を伝達する。これらのDSO+は、さらに、CXMUにより処理され、各々のDSO+に対し10番目のパリティビットが付加されて10ビットのDSO+が生成される。これらの10ビットのパケットは、DSO、NBS(9番目のビット信号)、および、パリティビットまたはデータインテグリティビットを含む(図7B)。10ビットのパケットは、HFCの分散ネットワーク11上でISU100に向かって伝送されるデータである。

下りチャンネルの中で挿入される10番目のビット、即ち、データインテグリティビットは、ISUにてデコードされチェックされる。さらに、このデータインテグリティビットは、前述したような上りチャンネル中の対応するチャンネルに対するパリティビットを算出して生成するために使用される。このようにして生成された上りチャンネルのパリティビットは、下りチャンネルまたは上りチャンネルにおけるエラーを表示するものであり、これから述べるようなチャンネルの保護または監視を実行するために使用される。

上り方向において、HDTを通過する反対方向のバスは、実質的に、HDT12を通過する順方向のバスを鏡に写したようなもので

ある。例えば、10番目のビットはCXMU56にて処理され、CXMU56からCTS U54に転送される信号は、図7Aのフォーマットに従っている。

DSUのラウンドトリップディレイは、すべてのデータバスについて同じである。下りCTS U出力からCXMU56を通過し、さらに、HFCの分散ネットワークを通過してISU100に達し、さらに、ISU100からHFCの分散

ネットワークに戻ってCXMU56を通過し、最後に、CTS U54に戻るまでの時間的な遅延は、これから詳細に説明するように、上り同期によって制御される。一般的にいえば、パスにおける遅延は、各々のISUについて測定される。このようにして測定した遅延が、正しいフレームの数になっていない場合、ISUにおけるパスに適切な遅延を付加することによって遅延の長さが調整される。

コアックスマスタユニット (CXMU)

コアックスマスタユニット56 (CXMU) は、図3に示すように、コアックスマスタカードロジック80 (CXMC) と、マスタコアックスカード (MCC) モデム82とを有している。既述したように、単一のHDT12には、最大6つのCXMU56が設けられる。これらの6つのCXMU56は、3対のCXMU56を構成する。各々の対のCXMU56は、6MHzの帯域にて伝送するように規定されている。さらに、各々の対のCXMU56は、一つのアクティブCXMUと、スタンバイのCXMUとを含む。このようにして、各々のCXMUに対し1対1の保護が実現される。図3に示すように、各々の対の両方のCXMUに対し、上り電話レシーバ16からの上り電話データが供給される。両方のCXMU共、同軸ライン22を介して下り電話トランスミッタ14に伝送する能力を有する。この場合、1対1の保護を実現するために、一つの制御信

号のみが要求されるのみである。ここで、1対1の保護とは、各々の対の一方のCXMU56が送信または受信に使用されることを意味する。

コアックスマスタカードロジック (CXMC)

CXMU56のコアックスマスタカードロジック80 (CXMC) (図8) は、HDT12、特にCTS U54のデータ信号と、HFCの分散ネットワーク11上でデータをトランスポートするためのモデムインタフェースとの間のインタフェースを提供する。CXMC80は、MCCモデム82に対する直接のインタフェースとなる。CXMC80はまた、HDT12と、6MHzの帯域でサービス動作を行う全てのISU100との間で多対1の動作を行わせるためのISU動作チャネルトランシーバの機能を遂行する。ここで、CXMU56は、6MHzの帯域内でデータのトランスポートを制御する。図8に示すように、CXMC

は、コントローラおよびロジック84と、下りデータ変換88と、上りデータ変換90と、データインテグリティ92と、I/Oトランシーバ96と、タイミングジェネレータ94とを有している。

下りデータ変換88は、CTS U54から送られる9ビットのチャネルフォーマット(図7A)から10ビットのチャネルフォーマット(図7B)への変換を遂行し、各々の下りチャネルについてHFCの分散ネットワーク11上でトランスポートされるデータインテグリティビットを生成する。この場合、データインテグリティビットは、奇数パリティを表している。さらに、下りデータ変換88は、少なくとも一つのFIFOバッファを備えている。このFIFOバッファは、下りCTS U出力にて存在する32のギャップビット72、74(図7A)を取り除くために使用され、且つ、コントローラおよびロジック84の制御の下で、10番目のデータインテ

グリティビットを各々のチャネルに挿入するために使用される。上りデータ変換90は、少なくとも一つのFIFOバッファを備えている。このFIFOバッファは、各々の上りチャネルに付加された10番目のビット(データインテグリティビット)を評価し、この評価結果として得られた情報をデータインテグリティ92に送り込む。さらに、上りデータ変換90は、10ビットのチャネルのデータの流れ(図7B)から、再度CTS U54にて使用するための9ビットのチャネルフォーマット(図7A)への変換を実行する。このようなデータ変換は、コントローラおよびロジック84の制御の下で実行される。

このコントローラおよびロジック84はまた、HFCのネットワーク11上で電話トランスポートを行うための呼び出し処理およびチャネル割当てを管理する。さらに、コントローラおよびロジック84は、当業者にとって周知のTR-303サービスや集中サービス等を提供するためにダイナミックタイムスロット割当てが使用されるようなモードにおいて、HFCの分散ネットワーク11上でのトラフィックの統計学的処理を継続する。さらにまた、コントローラ84は、6MHzの帯域において、チャネルにて生ずるエラーの統計学的処理を継続する。ここで、CX MUは、データをトランスポートし、全てのISU動作チャネル通

信に対するソフトウェアプロトコルを提供し、そして、対応するMCCモデム82に対する制御を実行する。

データインテグリティ92の回路は、上り変換回路90による各々の上りチャネルの10番目のビットの評価結果の出力を処理する。本発明のシステムでは、処理中に呼び出しを有するような予め規定されたチャネルに対してのみパリティが有効であることが保証される。ISUが休止状態になったときには、初期化され且つ活性化

したISUトランスミッタが停止するので、CXMにより実行されるパリティの評価は必ずしも有効ではない。ここで検出されるパリティエラーは、上りチャネルにおける送信エラーか、または、上りチャネルに対応する下りチャネルにおける送信エラーのいずれかである。

CXM80のISU動作チャネル(IOC)トランシーバ96は、コントローラおよびロジック84からのメッセージまたは制御データを保持するための送信バッファを有している。さらに、ISU動作チャネルトランシーバ96は、全体で8バイトの固定された長さを有する制御メッセージを、HFCの分散ネットワーク11上でのトランスポートを行うためのMCCモデム82に設けられた64kbpsのチャネル内にロードする。上り方向において、IOCトランシーバは、MCCモデム82を介して64kbpsのチャネルを受信する。ここで、MCCモデム82は、コントローラおよびロジック84に上記メッセージを供給する。

タイミングジェネレータ94は、HDT12内のアクティブCTSU54および保護用CTSU54の両方から送られる冗長性のシステムクロック入力を受信する。このようなシステムクロックは、2kHzのHFCマルチフレーム信号を含む。このHFCマルチフレーム信号は、HFCの分散ネットワーク内の全ての同軸脚部におけるラウンドトリップ遅延の同期をとるために、CTSU54により生成される。上記のHFCマルチフレーム信号は、ISU動作チャネル上のマルチフレームのアラインメントを表示すると共に、シンボルタイミングとトランスポートシステムのためのデータ再構築との同期をとるために使用される。CT

S U 5 4 から C X M U 5 6 へ送られる 3 2 チャンネルの 2 . 5 6 M H z の信号の最初の“ギャップ”ビットを表示するために、8 k H z のフレーム信号が供給され

る。S C N U 5 8 および C X M U 5 6 に供給するために、C T S U 5 4 により 2 . 0 4 8 M H z のクロックが生成される。C X M U 5 6 は、I S U 動作チャンネルや、C X M C 8 0 と M C C モデム 8 2 との間のモデム通信のために上記クロックを使用する。D S I U 4 8 と C T S U 5 4 との間のデータ信号の転送、および、C T S U 5 4 と C X M C 5 6 との間のデータ信号の転送のために、2 . 5 6 M H z のビットクロックが使用される。C X M C と M C C との間の 1 0 ビットデータチャンネルの転送のために、2 0 . 4 8 M H z のビットクロックが使用される。

マスター・コアックス・カード (M C C) モデム

C X M U 5 6 のマスター・コアックス・カード (M C C) モデム 8 2 は、H F C 分散ネットワーク 1 1 から送信及び受信するため、C X M C 8 0 に対する一方側と電話トランスミッター 1 4 とレシーバ 1 6 に対する他方側をインタフェースする。M C C 8 2 は、電話データと制御データの O F D M トランスポートのためにモデム機能を実行する。図 3 のブロックダイアグラムは、上り及び下り通信の両者のために M C C の関連した相互接続を識別する。M C C モデム 8 2 は、C X M U 5 6 の C X M C 8 0 を介して以外 H D T 1 2 に対するインタフェースを持っていないので、H D T 1 2 において独立モジュールではない。M C C モデム 8 2 は、H D T 1 2 のトランスポートシステムロジックを表す。このように、それは H F C 分散ネットワーク 1 1 上で情報トランスポートと関連したすべての要件を実行するため責任を有する。H D T 1 2 の C X M U 5 6 の各 M C C モデム 8 2 は、電話データと制御データトランスポートのための下りスペクトルにおいて 6 M H z の最大バンド幅を割当られる。6 M H z バンドの正確な位置は、C X M C 8 0 と M C C モデム 8 2 の間の I O C トランシーバ 9 6 を介して通信インタフェース上で C X M

C 8 0 により暫定的なものとするができる。電話及び制御データの下り送信は、約 7 2 5 から 8 0 0 M H z の R F スペクトルにある。各 M C C モデム 8 2 は

、約5から40MHzのRFスペクトル内でISUから制御データと電話データを受けするため、上りスペクトルにおいて最高6MHzを割当られる。再び、6MHzバンドの正確な位置は、CXMC80とMCCモデム82の間の通信インタフェース上でCXMC80により暫定的なものとする事ができる。

MCCモデム82は、上記記載のように20.48MHzの信号の形でCXMC80から256DSO+チャンネルを受ける。MCCモデム82は、すでにここで議論したように、OFDMに基づくマルチキャリア変調技術を用いてこの情報をすべてのISU100に伝送する。MCCモデム82は、HFC分散ネットワーク上で上り伝送の256DSO+マルチキャリアチャンネルを回復し、この情報をCXMC80を通過する20.48Mbpsストリームに変換する。前に記載したように、マルチキャリア変調技術は、直交位相振幅変調によるような、電話及び制御データをシンボルにコード化し、直交マルチキャリアのセット上の電話と制御データを変調するため、逆高速フーリエ変換技術を実行する。

シンボル整列は、ISU100のMCCモデム82及びISUモデム101により実行されるマルチキャリア変調技術のために必要な要件である。伝送の下り方向において、ISU100のすべての情報は、単一のCXMU56で発生し、各マルチキャリア上で変調された記号は自動的に位相整列する。しかしながら、MCCモデム82のレシーバにおける上りシンボル整列は、HFC分散ネットワーク11の多対点性及びISU100の等しくない遅延経路のために変化する。MCCモデム82での受信効率を最大にするため、す

べての上り記号は、狭い位相マージン内に整列しなければならない。これは、異なったISU100から上りを受けたすべてのチャンネルのシンボル期間が、それらがHDT12に到達する点で整列するような各ISU100における調整可能な遅延パラメータを利用することによりなされる。これは上り同期プロセスの一部であり、以下に記載される。加えて、マルチキャリアの直交性を維持するため、ISU100による上り伝送のために用いられるキャリア周波数はHDTに対して周波数ロックされなければならない。

CXMC80からMCCモデム82に入ってくる下り情報は、MCCモデム8

2に提供される2kHz及び8kHzクロックにフレーム整列される。2kHzマルチフレーム信号は、以下に詳細に記載するように、ISUに下りシンボルタイミングを伝達するため、MCCモデム80により用いられる。このマルチフレームクロックは、ISU100で電話データを正確に組み立て直すことができるようにするため、チャンネル応答を伝達し、マルチキャリアフレーム構成を示す。2つのkHzは10kHz（モデムシンボル比率）と8kHz（データフレーム比率）の間の最も大きい共通要素を表す。

すべてのISU100は、ISU100に求められるすべての下りタイミングを回復するため、関連するMCCモデム82により挿入される同期情報を用いる。この同期はISU100が下り情報を復調することを許容し、HDT12で受けたすべてのISU100送信が同じ基準に同期される。このように、すべてのISU100上り伝送に用いられるキャリア周波数は、HDT12に周波数ロックされる。

シンボル整列は、経路遅延調整、初期化及び活性化を提供することに加え、MCCモデム82の責任の下で下りと上り6MHzの同

期チャンネル上で実行され、そして、初期化と活性化がここで記載されるように完成するまでこのような同期チャンネルに供給する。これらのパラメータはIOCチャンネルの使用により追跡される。システムの重要性のため、IOCチャンネルと同期チャンネルは、MMCモデム82と、より活発な又は電話データの伝達のために使われるより少ないISU100の間の制御データのトランスポートのために異なった変調スキームを用いることができる。例えば、電話データは直交位相振幅変調を用いて変調することができ、一方、IOCチャンネルと同期チャンネルは、BPSK変調技術を利用することにより変調できる。

MCCモデム82は、ISU100によりマルチキャリア上で変調された電話データと制御データを復調する。このような復調は、電話トランスポートシステムの種々の実施例について以下に記載される。

MCCモデム82が責任を有するOFDMトランスポートシステムに関する機能は、少なくとも以下のものを有し、それらは更に詳細に種々の実施例に関し記

載されている。MCCモデム82は、同期チャンネル内のISUから同期パルス／パターンの受信した振幅／レベルを検出し、このレベルの表示をそれらの間の通信インタフェース上でCXMC80に通す。CXMC80は、その振幅レベルの調整のために均一化されたISU100に伝送のため、MCCモデム82にコマンドを提供する。MCCモデム82は、既知のシンボル境界に関し同期チャンネル上で変調された上りパターンを相関させ、そしてその間の通信上でCXMC80に対する必要なシンボル遅延訂正を通過させることにより、すべての上りマルチキャリアのシンボル整列のために備える。CXMC80は、MCCモデム82を介し、ISU100のシンボルを調整するため、ISU100

に下るメッセージを伝送する。全体的な経路遅延調整のためISU100を同期することに関し、MCCモデム82は、既知の基準境界に関しIOCチャンネル上でISU100により適当なバンド幅で変調された上りマルチフレームパターンを相関させ、そしてそれらの間のモデムインタフェース上でCXMC80に対する必要な経路遅延訂正を通す。CXMC80は、ISU100の全体の経路遅延を調整するため、IOC100チャンネル上でMCCモデム82を介し、メッセージを下りに伝送する。

二方向性多対点電話トランスポートの概要

以下はHFC分散ネットワーク上11上の電話と制御情報のトランスポートをまとめたものである。HDT12の各CXMU56が、その特定の上りと下りの動作周波数に関し供給される。CXMU56による上りと下りの伝送の帯域幅は、約725-800MHzのRFスペクトルの6MHz帯域の下り伝送で最高6MHzである。

下り方向において、CXMU56の各MCCモデム82は、暫定的6MHz帯域幅で同軸ライン22を介して、下り電話トランスミッター14に電気的な電話及び制御データ信号を提供する。HDT12のMCCモデム82からのRF電気の電話と制御データ信号は、合成信号に結合される。下り電話トランスミッターは、結合された電気信号を、一対の保護された下り光ファイダライン24上で変調のため冗長な電気-光変換器に通す。

下り光フィーダライン24は、電話情報と制御データをODN18に運ぶ。ODN18で、光信号は電気信号に変換され、下りビデオ情報（ビデオヘッドエンド供給ライン42から）と結合され電気の下りRF出力信号になる。電話情報と制御データを含む電気のRF出力信号は、ODN18により4つの同軸分散脚30に供給され

る。電話情報と制御データ下りは、各同軸脚部30に分散され、HFC分散ネットワーク11の同軸部分上で運ばれる。電氣的な下り出力RFは、同軸ケーブルからタップに接続され、図6に示すディプレックスフィルタ104を通してISU100の受信モデム101上で終わる。

RF電気出力信号は、直交周波数分割多重化技術を利用してMCCモデム82により、直交マルチキャリア上で変調された電話情報と制御データを有している。電話情報と制御データはシンボルデータにマップされ、シンボルは高速フーリエ変換技術を用いて複数の直交キャリア上で変調される。シンボルは、すべてシステム11の多数ポイントに伝送される単一のポイントでキャリア上で変調されるので、マルチキャリアの直交と直交マルチキャリア上で変調されたシンボルのシンボル整列は、自動的にHFC分散ネットワーク上でトランスポートのために整列し、そして、電話情報と制御データは、モデム101によりISUで復調される。

ISU100は、HFCネットワーク11の同軸部分の同軸ケーブルからタップを取ったRF信号を受ける。ISU100のRFモデム101は、信号を復調し、適切にチャンネルユニット103に供給のためCXSU制御器102に抜き出された電話情報と制御データを通す。ISU100は、電話情報が加入者又は顧客が使うために変換されるインタフェースを表す。

HDT12のCXMU56とISU100は、通信システム10の二方向性多対点電話伝送システムを実行する。CXMU56とISUは、それゆえ、モデム機能を実行する。本発明によるトランスポートシステムは、トランスポートシステムのためのモデム機能性を実行するため3つの異なったモデムを利用することができる。第1のモデムはHDT12の各CXMU56に配置されたMCCモデ

ム82である。例えば、HDT12は、アクティブMCCモデム82(図3)を有し、多対点トランスポートネットワークを表す多くのISUをサポートすることができる。MCCモデム82は、HDT12によりISUを制御するため制御データトランスポートと同じく電話情報トランスポートを調整する。例えば、制御データは、呼出し処理メッセージ、ダイナミック配分及び割当メッセージ、ISU同期制御メッセージ、ISUモデム制御メッセージ、チャンネルユニット供給、及び他のISU操作、管理、維持、供給(OAM&P)情報を有することができる。

第2のモデムは、単一家族の加入者又は単身居住住居ユニットをサポートするために最適のHISUモデムである。そのため、コストが低く、電力消費は少ない。第3のモデムは、多数加入者又はMISUモデムであり、それは一般に住居及びビジネスサービスの両方をサポートすることが求められている。

HISUモデム及びMISUモデムは幾つかのフォームをとることができる。例えば、HISUモデム及びMISUモデムは、本発明の種々の実施例に関して以下に詳細に記載されるように、HDT12から伝送されるマルチキャリアの小さな部分又はHDT12から伝送されるマルチキャリアのより大きな部分のみを取り出すことができる。例えば、HISUはHDT12からトランスポートされた電話情報の20マルチキャリア又は10ペイロードチャンネルを抜き出すことができ、MISUはHDT12からトランスポートされた260マルチキャリア又は130ペイロードチャンネルからの情報を抜き出すことができる。これらモデムの各々は、HDT12によりトランスポートされた信号から制御データを取り出すため分離した受信部分、及びHDT12からトランスポートされたマルチキャリア上で変調された電話情報を取り出すためのHISUモデム

の追加のレシーバ部分を用いることができる。これは帯域外ISUモデムとして以下に参照される。帯域外ISUモデムとともに用いるMCCモデム82は、直交キャリア波形内又は直交キャリアからいくらかオフセットしたキャリア上で制御情報を変調することができる。帯域外ISUモデムに対して、HISU及びMISUモデムは、ISUモデムのために単一レシーバを利用することでき、単一

レシーバのモデムを利用するため電話情報と制御データの両者を取り出すことができる。これは、帯域内ISUモデムとして以下に参照される。この場合、制御データは直交キャリア波形内のキャリア上で変調されるが、しかし、異なるキャリア変調技術を利用することができる。例えば、キャリア上で制御データの変調のためのBPSKはQAM技術によるペイロードキャリア上の電話データと反対である。加えて、異なる変調技術は、制御データと電話データのための上りと下りの伝送に用いることができる。例えば、下り電話データは256QAMを利用することによってキャリア上で変調でき、下り電話データは32QAMを利用することによりキャリア上で変調できる。変調技術が伝送に利用されるものなんでも、何の復調アプローチがトランスポートシステムの受信端で用いられるかを規定する。HDT12からトランスポートされた下り電話情報と制御データの復調は、異なるモデムの実施例のブロックダイアグラムを参照して更に詳細に以下に説明する。

上り方向において、ISU100での各ISUモデム101は、約5から40MHzのRFスペクトルの6KHz帯域幅で少なくとも一つの直交マルチキャリア上で上りに伝送する。上り6MHz帯域は、伝送が受信される下り6MHz帯域に対応する。上りの電気の電話及び制御データ信号は、図1に示されているように、ISUモデム101により、個々の同軸ケーブル脚30を介してそれぞれ

接続された光分散ノード18にトランスポートされる。ODN18で、種々のISUからの上り信号は、結合され、光ファイダライン26を介してHDTに光学的に伝送される。前に検討したように、種々のISUからの上り電気信号は、一部分、結合され合成上り光信号になる前にシフトした周波数かもしれない。このような場合、電話レシーバ16は対応する下りシフトした電気回路を有する。

多数ISU100から単一HDT12へのHFC分散ネットワーク上の伝送の多対点性により、直交周波数分割多重化技術を利用するため、ISU100により各キャリア上で変調されるシンボルは、一定の位相マージン内で整列しなければならない。加えて、以下にさらに詳細に検討されているように、通信システムにおけるHDT12のネットワークインタフェース62からすべてのISU10

0へ、そしてISU100からネットワークインタフェース62への一周経路の遅延を等しくしなければならない。マルチフレームの完全さをシグナリングすることがこのシステムを通して保持されるためこれは必要である。加えて、適当な振幅の信号は、ISU100に関し制御機能を実行するため、HDT12で受信されなければならない。同様に、ISU100からOFDMトランスポートに関し、ISU100は、HFC分散ネットワーク11上でトランスポートされたマルチキャリアが直交して整列するようにHDTに周波数ロックされなければならない。トランスポートシステムは、以下に記載するように、直交周波数分割多重化を利用してこの多対点伝送を実行するための分散されたループ技術を実行する。HDT12が直交的に整列しそして整列したシンボルとその上に変調された電話及び制御データを持つ複数のマルチキャリアを受けた時、CXMU56のMCCモデム82は、対応する6MHzで複数のマルチキャリアからの電話情報と制御データを復調し、ネットワークインタフ

ェース62に配達するためCTS U54に電話データを、そして電話トランスポートの制御のためCXMC80に制御データ提供する。この分野の当業者であれば気がつくように、設計上の選択であるスペクトル配分、周波数割当、データ比率、チャンネル数、提供されるサービスのタイプ、及びシステムの他のパラメータ又は特性は、単に例として取り上げたものである。添付された請求の範囲に記載された発明は、このような設計上の選択を予期しており、それらはそのような請求の範囲の範囲内に含まれる。加えて、多くの機能がソフトウェア及びハードウェアにより実行することができ、参照されるものが一つ又は他方であったとしても、どちらかの実行が請求の範囲に基づいて予期できるものである。

電話トランスポートシステムの第1の実施例

本発明による電話トランスポートシステムの第1の実施例は、MCCモデム82、及び一般に図6においてISUモデム101として示されたHISUモデムとMISUモデムのブロックダイアグラムを有する図9-23を参照して個別に記載する。このようなモデムは、上りと下りのモデムトランスポート機能性を実行する。以下の記載はこのようなモデムを利用した動作の理論に関する検討であ

る。

図9Aを参照すると、OFDM技術を利用した電話情報と制御データの上りと下りのトランスポートのための一つの6MHz帯域のスペクトル配分が示されている。波形は好ましくは、19.2Mbpsのネットデータ比率に適應するための480キャリア又はトーンを有する240ペイロードチャンネル又はDSO+チャンネル、46キャリア又はトーンを有する24IOCチャンネル、及び2同期チャンネルを持っている。各同期チャンネルは、二つのキャリア又はトーンを有しており、ガードトーンとして利用される10の使用されて

いないキャリア又はトーンにより、24IOCチャンネル及び240ペイロードチャンネルから各々オフセットされている。キャリア又はトーンの総計は552である。更に以下に記載されるように、同期機能のために利用される同期トーンは6MHzスペクトルの端に位置しており、6MHz帯域の複数の直交キャリアは、6MHzスペクトルの各端でガード帯域(516.0kHz)により6MHz帯域に近いキャリアから分離されている。ガード帯域はシステムのトランスミッターとレシーバでフィルタ選択度のために許容する6MHz帯域の各端で提供される。同期キャリアは、もし初期化及び活性化の間に同期のために利用される同期キャリアが6MHz帯域内の他のトーン又はキャリアと直交していない場合、同期信号は直交的に整列した波形の構成を破壊するのを防ぐような電話データ又はペイロードキャリアからオフセットされる。同期トーンは、それ故、同期チャンネルは特別なIOCチャンネルと見なすことができるが、帯域のペイロードキャリア及び点在したIOCチャンネルの主体の外側である。

ISUのパワー要件を最小にするため、ISUが処理する帯域幅は最小化される。このように、電話ペイロードチャンネル及び6MHz帯域のIOCチャンネルは、10ペイロードチャンネル毎に位置しているIOCチャンネルと電話ペイロードチャンネルにおいて点在している。このような分散された技術で、10より大きいペイロードチャンネルのサブ帯域はIOCチャンネルを有しており、ISUが「合う」帯域幅の量はIOCチャンネルがISU100と通信するためHDT12のために利用可能であるよう制限される。図9Aに示されているスペクトル配分のための

このようなサブ帯域分散は図9Dに示されている。6MHz帯域幅に24のサブ帯域があり、各サブ帯域は5番目と6番目のパイロードチャンネルの間にI/Oチャンネルを持つ

た10パイロードチャンネルを含んでいる。6MHz帯域を通してI/Oチャンネルを分散している利点は、狭い帯域進入(ingress)からの保護である。もし進入がI/Oチャンネルを破壊するならば、利用可能な他のI/Oチャンネルがあり、HDTは6MHzの異なった部分にISU100を調節することができ、そこは壊れていないI/Oチャンネルが位置する。

好ましくは、MISU66は、帯域幅がHDT12からMISU66に通信するため多数のI/Oチャンネルを含む130パイロードチャンネルまで受信するため、6MHzの帯域幅のほぼ3MHzに合う。HISU68は、HDT12で通信するため少なくとも一つのI/Oチャンネルを有する11チャンネルを受け取るため、6MHz帯域幅の約100kHzを合う。

下りと上りの経路の間第1の差は、下りの同期と上りの同期である。下り方向において、すべてのISUはHDTからの情報をロックする。ISUの初期化と活性化は、上り同期チャンネルに供給される信号に基づいている。操作の間、ISUはI/Oチャンネルを介して同期を追跡する。上りにおいて、周波数制御は以下に記載されているように下り同期チャンネルのみを利用して提供することもできるが、上り同期プロセスは、振幅、周波数、及びタイミングの分散された(多対点)を含んでいる。上り同期のプロセスは、二つの上り同期チャンネルにおいて、第1の又は第2の同期チャンネルを生じる。

図10を参照すると、MCCモデム82の下り伝送アーキテクチャーが示されている。およそ各々10Mbpsの二つの直列データ入力、8kHzフレームクロック入力によりクロックされているCXC56からのパイロードデータを有している。CXC56から入力されたI/O制御データはI/Oクロック入力によりクロ

ックされ、それは好ましくは2.0kHzである。電話パイロードデータ及びI

OC制御データは、直列ポート132を通過して入り、該データは当業者に知られているように、HFC分散ネットワーク11上で伝送される波形のランダムさを提供するためにスクランブラー134によりスクランブルされる。スクランブルが無いと波形に大変高いピークが生じるが、しかし波形がスクランブルされると、MCCモデム82により発生されるシンボルは十分にランダムとなり、そのようなピークは十分制限される。スクランブルされた信号はシンボルマッピング機能136に加えられる。シンボルマッピング機能136は、入力ビットを取り、そしてそれらを複合星座点(complex constellation point)にマップする。例えば、入力ビットがBPSK信号の出力のためのシンボルにマップされた場合、各ビットは、図9CのBPSKのためのマッピングダイアグラムにあるように、星座の単一のシンボルにマップされる。このようなマッピングは、データとして同相で直交位相値(I/Q値)となる。BPSKは好ましくは上りと下りのIOCチャンネル及び同期チャンネルに使われる変調技術である。BPSKエンコーディングは、前に検討したシステムに活性を提供するため、IOC制御データのために好ましい。QPSK変調のため、すべての2ビットは星座点を表す4つの複合値の1つにマップする。好ましい実施例では、32QAMは電話ペイロードデータのために利用され、そこではすべての5ビットのペイロードデータは、図9Bに示されているように32星座点の1つに移される。このようなマッピングはI/Q値に帰着する。そのようなものとして、DSO+信号(10ビット)は、二つのシンボルで表され、二つのシンボルは二つのキャリアを用いて伝送される。このように、ひとつのDSO+チャンネルは二つのキャリア又は6MHzスペクトルのトーンにトランスポートされる。

当業者は、種々のマッピング又はエンコーディング技術が異なったキャリアで利用できることを認識している。例えば、ISDNを運ぶ電話チャンネルはQPSKを用いてコード化でき、反対にPOTSを運ぶ電話チャンネルは32QAMを用いてコード化される。そのため、異なったサービスを運ぶ異なった電話チャンネルは、このような品質を求めるこれらのサービスのためにより活性化した電話チャンネルを提供するため、異なって変調される。本発明によるアーキテクチャ

一は、異なったチャンネルに用いられる変調技術からいずれかのチャンネルを異なってコード化しそして変調するためフレキシビリティを提供する。I/Q値により表される各シンボルは、シンボルバッファ138の高速フーリエ変換(FFT)ビン(bin)に移される。例えば、8kHzフレームレートで動作しているDSO+として、5ビットが一つのFFTビンにマップされ、5ビットが別のビンに移される。シンボルバッファ138の各ビン又はメモリの位置は、I/Q値としての周波数ドメインのペイロードデータ及び制御データを表す。FFTビンの一つのオフセットは、当業者に知られている逆FFTを通してタイムドメインにマップされる。逆FFTは、複合I/Q値をFFTポイント数に対応したタイムドメインサンプルに移す。ペイロードデータとIOCデータの両者は、バッファ138にマップされ、そして逆FFT140によりタイムドメインサンプルに変換される。FFT140のポイント数は変化させることができるが、しかし、好ましい実施例ではポイント数は256である。256ポイントFFTのための逆FFT140の出力は、波形の256タイムドメインサンプルである。

逆FFT140は同相で直交位相(I/Q)の要素FFT1及びFFT0のための分離した直列出力を持っている。デジタル・アナログ・コンバータ142は、ベース帯域変調された信号の数の表

示である同相で直交位相の要素を取り、そしてそれを分離した波形に変換する。信号はそれから、調波の内容を取り除くために再構成フィルタ144を介して通る。この再構成は、多数ミキシングスキーム及び他のフィルタリング問題から生ずる問題を避けるために必要である。信号は、適用可能な伝送周波数に混合するため、同相及び直交位相要素とデジタル的に調整可能な合成された波形を利用してI/Q要素をアップ変換するため、変換トランスミッタ146において合計される。例えば、もしシンセサイザが600MHzであれば、出力周波数は600MHzである。

要素は信号変換トランスミッタ146により合計され、複数の直交キャリアを有する波形は、電話トランスミッタ14により光ファイバー上に結合される前に、トランスミッター増幅器148により増幅され、トランスミッターフィルタ1

50により濾波される。このような機能は、このような変調を実行するために必要な一般的目的のプロセッサ149及びブロック47の他の処理回路の制御下で実行される。一般目的のプロセッサは、以下に記載されるように分散されたループシンボル整列、周波数ロック、振幅調整、及び経路遅延機能を実行するため、キャリア、振幅、タイミングリカバリーブロック222(図15)からのISU調整パラメータを受ける。

下り受信端において、MISU又はHISUの何れかは、6MHz帯域幅の一つにおいて下り伝送から電話情報と制御データを取り出すために提供する。MISU66に関し、MISU下りレシーバアーキテクチャーは図11に示されている。それは受信した600MHzから850MHzトータル帯域ブロードキャストの下りの周波数帯域を減少させるため、100MHz帯域通過フィルタ152を有する。濾波された信号は、帯域干渉を取り除き、そして更に帯

域幅を減らすため、電圧調整されたフィルタ154を通して通過する。信号は、直交位相及び同相ダウン変換器158を介してベース帯域周波数にダウン変換され、ダウン変換器158では信号は直列ポート178の出力から制御されるシンセサイザ157を利用した複合ミキサ156で混合される。ダウン変換されたI/Qは要素は、フィルタ159を介して通過し、そしてアナログデジタル変換器160でデジタルフォーマットに変換される。I/Q要素のタイムドメインサンプルは、サンプルバッファ162に置かれ、サンプルのセットはダウン変換器補償ユニット164に入力される。補償ユニット164は、ダウン変換器で生じるミキサ及び差動位相遅延からのDCオフセットのようなエラーを軽減することを試みる。

キャリア、振幅、及びタイミングシグナリングは、キャリア、振幅、及びタイミングリカバリーブロック166により、図22Aを参照して以下に記載するように、トラッキングの間のISUとIOCの初期化と活性化の間、同期チャンネルから制御データを取り出すことにより、補償信号から取り出される。平行なフォームの補償された信号は、MISUが含むDSO+チャンネルのためMCCモデム82で当初上りを創り出したI/Q要素を有した本質的に複合星座ポイントであ

る周波数ドメイン素子のベクトルに変換するため、高速フーリエ変換（FFT）170に供給される。チャネルフィルタリングにおける不正確さのため、イコライザ172は送信及び受信の間に生ずるダイナミックエラーを取り除く。上りレシーバと下りレシーバにおける同等化し、図23を参照して以下に更に説明する。イコライザ172から、複合星座ポイントはスクランブラー134のミラー素子である復スクランブラー176で元にもどされるシンボルビット変換器174によりビットに変換される。そして、ペイロード電話情報とIOC制御データは直列ポート178により

図6に示されたCXSU102に出力される。ブロック153は、そこに示すように、種々の機能を実行するための処理能力を有している。

図12を参照すると、HISU68下りレシーバアーキテクチャが示されている。HISU下りレシーバアーキテクチャ（図11）とMISU下りレシーバアーキテクチャ（図11）間の第1の差は、処理される帯域幅の量である。FFT処理までのレシーバのフロントエンドは、ダウン変換の間、アナログデジタル変換器160が非常に遅く動作させられることを除き、実質的に同じである。例えば、もし処理される信号の帯域幅が100kHzであるなら、サンプル比率はおおよそ200kHzである。MISU処理3MHz信号において、サンプル比率は約6MHzである。HISUは受信を最大10DS0+に制限しているので、FFT180はより小さなサイズにすることが出来る。A32ポイント180は、好ましくはHISUで用いられ、MISUで利用される128又は256ポイントFFTに比べてより効率的に実行できる。そのため、これらアーキテクチャー間の主たる差は、HISUレシーバアーキテクチャはMISUレシーバより実質的により小さな処理能力を必要としており、より少ない電力消費となる。このように、リモートユニットでの電力消費を最小にするシステムを提供するため、HISUに合うより小さな帯域の周波数は、このように低消費を許容する。HISUがこのようなキャリアの小さな帯域に合うことを許容される一つの理由は、IOCチャンネルが6MHzスペクトルを通して点在しているからである。

図13を参照すると、HISU68用の上りトランスミッタアーキテクチャが示される。CXSU102(図6)からのIOC制御データ及び電話ペイロードデータは、HISUにおいて、MISU

又はHDTトランスミッタアーキテクチャの場合よりもはるかに遅いレートでシリアルポート182に供給される。なぜなら、HISUは10本のDSO+チャネル分のみサポートするからである。HISU上りトランスミッタアーキテクチャは3つの重要な動作を実施する。それは、伝送された信号の振幅、伝送された信号の時間遅延(シンボル及びパス遅延)及び伝送された信号のキャリア周波数を調整する。電話データ及びIOC制御データは、HISU下りレシーバアーキテクチャのクロックジェネレータ173によって生成されたクロック信号の制御を受けてシリアルポート182に入り、そして、MCC下りトランスミッタアーキテクチャに関して上述した理由からスクランブラ184によってスクランブルされる。入力されるビットは、ビット対シンボルコンバータ186により、周波数領域においてI/Q成分を含むシンボル或いは複素群点にマッピングされる。次いで、群点はシンボルバッファ188に取り込まれる。バッファ188の後段には、逆FFT190が、シンボルに対応して時間領域でのサンプルすなわち32ポイントFFTに対応する32個のサンプルを生成するように接続されている。逆FFT190の出力側には、ディレイバッファ192が、HDT12によって制御される上り同期プロセスの関数として、MCCモデムの上りレシーバアーキテクチャにてマルチフレーム整列を提供するように接続されている。従って、ディレイバッファ192は、逆FFT190の出力の同相及び直交成分のデジタル/アナログコンバータ194によるデジタル/アナログ変換に先立って、パス遅延調整を行う。クロックディレイ196は、スクランブルされる前にシリアルデータストリームから制御データを抽出することにより得られるIOC制御データ出力の要求に基づいてシンボル整列のための微調整を行う。デジタル/アナログコンバータ194によるアナロ

グ成分への変換後、そのアナログ成分は、再生フィルタ198によって平滑なア

ナログ波形に再生される。次いで、上り信号は、ダイレクトコンバータ197により直接、シンセサイザブロック195の制御の下に適当なトランスミット周波数に変換される。シンセサイザブロック195は、I O C制御チャネルからのコマンドの制御を受けて動作する。このI O C制御チャネルは、H I S U下りレシーバアーキテクチャにおいて抽出されているのでキャリア周波数調整コマンドを提供する。次いで、変換された信号は、トランスミッタ増幅器200によって増幅され、トランスミッタフィルタ202によって濾波され、そして上り側に伝送されて、他のI S U 1 0 0によって伝送された他の信号と組み合わせられる。ブロック181はそれぞれの機能を実行するための処理回路を含む。

図14を参照すると、M I S U 6 6用の上りトランスミッタアーキテクチャが示され、H I S U 6 8用の上りトランスミッタアーキテクチャと実質的に同じである。しかしながら、M I S U 6 6は、より多くのチャネルを扱い、H I S U 6 8では可能であるところの単一のプロセッサ上での動作を実行することはできない。従って、逆F F T 1 9 1を含むブロック181の機能を提供するブロック181のプロセッサと、そのアーキテクチャをサポートする汎用プロセッサ206は共に、増えた分のチャネル容量を扱う必要がある。

図15を参照すると、H D T 1 2における各C X M U 5 6のM C C上りレシーバアーキテクチャが示される。5~40MHzのバンドパスフィルタ208は上り信号を濾波する。この上り信号は、ミキサ及びシンセサイザ回路211によるベースバンドへのダイレクトダウン変換を受ける。ダウン変換された出力は折り返し防止フィルタ201に入力され、そして、その出力信号はアナログ-デジタルコンバータ212によってデジタル形式に変換される。各ア

ナログ-デジタルコンバータ212は、信号の同相及び直交成分の時間領域でのサンプリングを行い、狭帯域イングレスフィルタ及びF F T 1 1 2に供給する。この狭帯域イングレスフィルタ及びF F T 1 1 2は、以下に記述するように、上り伝送に影響を与える可能性のある狭帯域干渉からの保護を提供する。

狭帯域イングレスフィルタ及びF F T 1 1 2は、一度に10チャネルを保護する。従って、もしもイングレスが、M C Cモデム82によって受信される6MH

z スペクトルにおいて使用可能な 240 本の $DSO + s$ のうち 1 本に影響を与えたならば、最大 10 チャンネルがそのイングレスによって破壊されることになるであろう。狭帯域イングレスフィルタ及び FFT 112 は、通常のフィルタ技術として当業者には認識されるように、多相構造を有している。また、その多相フィルタによって保護されるチャンネルの数を変えることができることは当業者には認識されるであろう。狭帯域イングレスフィルタ及び FFT 112 の出力は、チャンネルにおいて発生する誤り、例えば基準オシレータ又はシンセサイザからのノイズに起因する誤り、を訂正するためのイコライザ 214 に供給される。イコライザ 214 の出力シンボルは、シンボル対ビットコンバータ 216 に供給され、そこでシンボルがビットにマッピングされる。ビットは、ISU100 のスクランブラとはミラーの関係にあるデスクランブラ 218 に供給され、該デスクランブラの出力はシリアルポート 220 に供給される。シリアルポートの各出力は、下り方向の MCC 下りトランスミッタアーキテクチャに供給されるように 2 つのペイロードストリームと 1 つの IOC 制御データストリームに分割される。ブロック 217 は、それぞれの機能を実行するための必要な処理回路を含む。

下り情報を検出するためには、下り同期プロセスを用いて到来信

号の振幅、周波数及びタイミングを獲得しなければならない。下り信号は点对多点ノードトポロジを構成するので、OFDM 波形は、上り信号とは対照的に、本質的に同期した形態で単一のパスを介して到来する。波形パラメータの獲得は、先ず、6 MHz スペクトルの最終部分に位置する下り同期バンドにおける下り同期チャンネル上で行われる。これらの同期帯域は、2 kHz のフレームクロックによって BPSK 変調された単一の同期キャリア又はトーンを含む。このトーンは、ISU において初期の振幅、周波数及びタイミングを抽出するのに用いられる。同期キャリアは、受信帯域の中心部分に位置してもよく、また IOC の特別なケースと見なすことができるであろう。信号が受信され、そのレシーバアーキテクチャが典型的な IOC チャンネルに調整された後、その同じ回路が IOC チャンネルを用いて同期パラメータを追跡するのに用いられる。

必要な信号パラメータを獲得するのに用いられるプロセスは ISU レシーバ

アーキテクチャのキャリア、振幅及びタイミング再生ブロック166を利用し、該ブロックは図22Aにおいてブロック図の形でより詳細に示される。キャリア、振幅及びタイミング再生ブロック166は、受信波形に対して周波数ロックを行うのに用いられるCostasループ330を含む。補償ユニット164から信号が受信されると、その信号はサンプルホールド334及びアナログ-デジタルコンバータ332に入力され、該コンバータ332から出力された信号はCostasループ330に供給される。サンプリングは、電圧制御型オシレータ340の制御の下に、レシーバアーキテクチャで用いられるFFTのポイント数Mだけ分割を行うディバイダ333によって分割されるように、行われる。Costasループ330のミキサ331は、到来信号とフィードバックパスの供給を受け、ループ位相検出器として機能する。ミキサ33

1の出力は、濾波されると共に、その後のハードウェアの処理量を低減するために $1/10$ 単位で処理される。もし受信信号が帯域的に制限されているならば、同期信号を表すのにそれ程多くのサンプルは必要としないであろう。もし直交性がレシーバにおいて保存されないならば、フィルタは所望としない信号成分を再生プロセスから除去するであろう。直交性があるという条件の下で、LPF337は隣合うOFDMキャリアからの影響を完全に除去することになる。キャリア周波数ロックが達成されると、ループの同相側において所望とするBPSK波形が出現する。デシメータの出力は別のミキサを介して供給され、 $H(s)$ のフィルタ関数を持つループフィルタ及び数値制御型オシレータ(NCO)を介して処理され、最終的に周波数誤差を訂正するためのフィードバックパスを構成する。誤差が「小さい」レベルにある時、ループはロックされる。追跡動作中に高速の獲得及び最小のジッタを達成するためには、デュアルループバンド幅を用いる必要があるであろう。システム動作は、OFDMチャンネル間隔(360Hz)の約 $\pm 4\%$ 以内で周波数ロックが達成され且つ維持されることを必要とするであろう。

信号の振幅は、BPSK電力検出器336における周波数再生ループの出力端で測定される。トータルの信号電力が測定され、そして、数値可変型アナログゲ

イン回路（図示せず）を調整するのに用いることができる。ゲイン回路は、アナログ-デジタルコンバータが最適な動作領域で用いられるように信号を正規化するためのものである。

タイミング再生は、タイミング誤差を抽出するための早-遅ゲート形位相検出器338の早-遅ゲート形アルゴリズムを用いて、さらに誤差信号に応答するサンプルクロックオシレータ340を調整することにより、行われる。早-遅ゲート形検出器は、更新間隔の

間に進み-遅れコマンドを出力する。このコマンドはフィルタ341を介してサンプルクロックオシレータ340に印加される。このループは、周波数のロック及び振幅のロックが達成されるまで保持される。タイミングループがロックされると、ロック指示信号が生成される。また、同じクロックは上り伝送用に用いられる。キャリア、振幅及びタイミング再生ブロック166は、クロックジェネレータ168用の基準信号を提供する。クロックジェネレータ168は、MISUが必要とする全てのクロック、例えば8kHzフレームクロック及びサンプルクロック、を提供する。

MCCモデム上りレシーバアーキテクチャ（図15）のキャリア、振幅及びタイミング再生ブロック222が、図22Bの同期ループ図によって示される。これは、上り同期チャンネル上の信号に関して上り同期のための検出を行う。ISUの初期化及び活性化のために、上り同期は、ISUの1つに対し下りIOC制御チャンネルを介して基準信号を同期チャンネルの上り側に送出するよう指令するHDTによって行われる。キャリア、振幅及びタイミング再生ブロック222は、同期チャンネルにตอบสนองし且つHDT12における基準信号に対する周波数誤差、振幅誤差及びタイミング誤差を評価するISU100からのデータのパラメータを測定する。キャリア、振幅及びタイミング再生ブロック222の出力は、HDT12によって調整コマンドに変換され、MCC下りトランスミッタアーキテクチャによってIOC制御チャンネル上の下り方向で初期化され且つ活性化されつつあるISUに送出される。

上り同期プロセスの目的は、別々のISUからの波形がHDT12で合わさっ

て統合波形となるように、ISUを初期化し且つ活性化することである。HDT 12においてキャリア、振幅及びタイミング再生ブロック222によって評価され、且つISUによって調

整されるパラメータは、振幅、タイミング及び周波数である。ISUの信号の振幅は、DSO+sが等しい量の電力を割り当てられるように正規化され、HDT 12において所望の信号対雑音比を達成する。更に、隣合うISUは正しい相対的なレベルで受信されなければならない。さもなければ、相対的に弱いDSO+チャンネルは、相対的に強いDSO+チャンネルの過渡的な振る舞いによって不利な影響を受けるであろう。もしペイロードチャンネルがかなりの周波数誤差を持つ別のペイロードチャンネルに隣接して伝送されたならば、OFDM波形における直交性は劣化し、誤差レート性能は悪化する。従って、ISUの周波数は、精密な許容誤差に調整されなければならない。再生された信号のタイミングもまた直交性に影響を与える。隣合うシンボルについて時間合わせされていないシンボルは、FFTプロセスの影響を受けるシンボルの一部分内で変化を作り出すことができる。もし全てのシンボルの変化がHDTにおけるガード間隔内に有るならば、非直交チャンネルに対して約±16トーン(8DSO+s)が再生不可能となるであろう。

上り同期の間、ISUは、振幅及び周波数精度を確立し且つシンボルを合わせるための信号、例えば方形波信号、を送出するよう指令を受ける。パターン信号は、キャリア、振幅及びタイミング再生ブロック222によってパラメータの検出が行える信号であればどのような信号でもよく、このような信号は異なるパラメータを検出するために異なってもよい。例えば、その信号は、振幅及び周波数の検出及び訂正用として連続した正弦波であってもよいし、シンボルタイミング用として方形波であってもよい。キャリア、振幅及びタイミング再生ブロック222は、3つの分配されたループパラメータを評価する。3つのループの全てにおいて、結果として生じる誤差信号はCXMC80によってコマンドに変換され、MCC

モデム82を介してI O Cチャンネル上に送出される。そして、C X S Uは、そのコマンドを受信し、I S Uによって行われる調整を制御する。

図22Bに示されるように、I S Uからの上同期は、サンプルホールド(434)され、電圧制御型オシレータ440の制御の下にアナログ-デジタル変換される(432)。この電圧制御型オシレータは局部基準オシレータであり、レシーバアーキテクチャにおけるFFTのポイントであるMで分周を行い、サンプルホールド434及びアナログ-デジタルコンバータ432を制御するためにkで分周を行って、8kHz信号を位相検出器438に印加する。

周波数誤差は、C o s t a sループ430を用いて評価してもよい。C o s t a sループ430は、局部的に生成された基準周波数との位相ロックを確立するよう機能する。時間が経過すると、ループ適応性がディセーブルとされ、時間に関する位相差が周波数誤差を評価するのに用いられる。周波数誤差はフィルタ関数 $H(s)$ 444によって発生され、C X M C 82に供給されて、周波数調整コマンドをI O C制御チャンネルを介してI S Uに送るための処理が行われる。また、周波数誤差は数値制御型オシレータ(N C O)に供給されて、周波数誤差を訂正するための周波数ループが完成する。

振幅誤差は、上り同期の期間中、電力検出器436によってC o s t a sループ430の同相側のキャリアの振幅を検出することにより、キャリアの大きさに基づいて計算される。振幅は、基準コンパレータ443において所望の基準値と比較され、その誤差はC X M C 82に供給されて、振幅調整コマンドをI O C制御チャンネルを介してI S Uに送るための処理が行われる。

H D Tにおいて局部基準周波数が位相ロックを達成すると、I S

Uから到来する同期チャンネル上のB P S K信号が処理のために得られる。方形波は、C o s t a sループ430の同相側で得られ、早-遅ゲート形位相検出器438に供給されて、ティバイダ435から局部的に発生された8kHz信号との比較が行われる。位相検出器435は、ループフィルタ441に印加され且つライン439を介して出力された位相又はシンボルのタイミング誤差を生成する。次いで、位相又はシンボルのタイミング誤差はC X M C 82に供給されて、シン

ボルタイミング調整コマンドをI O C制御チャネルを介してI S Uに送るための処理が行われる。

上り同期のためのパラメータを調整するI S Uのメカニズムは、時間領域での波形のスカラ積をもって振幅を変化させる手段を有しており、このスカラ積は、デジタル-アナログコンバータ194(図13)によってデジタル処理アルゴリズム、例えば逆FFT190、から集められるものである。同様に、複素ミキシング信号を作り出し、デジタル-アナログコンバータ194の入力端に印加される複素倍数として与えることができるであろう。

I S Uにおける下りのサンプルクロック及び上りのサンプルクロックの周波数の精度は、オシレータを下り同期及びI O C情報に位相ロックすることにより確立される。上り伝送周波数は、例えば、H D T 1 2によって指令を受けるセンスサイザブロック195において調整される。

シンボルタイミングの訂正は遅延関数として与えられる。従って、I S Uの上り方向におけるシンボルタイミングの時間合わせは、サンプル間隔(同時に出ていくべき同じ2つのサンプル)をブランクとすることにより、或いはクロックディレイ196(図13)を介して余分のクロックエッジ(1つのサンプルはクロックが出てしまっていて失われている状態)を差し挟むことにより達成される

サンプルタイミングの遅延として確立される。このようにして、既に必要とされている以上のデータ記憶オーバーヘッド無しで、遅延関数を制御することができる。

I S Uがシステムにおいて初期化され活性化されると、伝送の準備のために、I S Uは、必要とされる上りの同期システムパラメータをキャリア、振幅及びタイミング再生ブロック222を用いて維持する。使用されないが初期化され且つ活性化されたI S Uは、I O C上に伝送を行うよう指令を受け、そして、ブロック222はそこからのパラメータを上述したように評価する。

M I S U 6 6 (図13)及びH I S U 6 8 (図14)用の上りトランスミッターアーキテクチャにおいて、H D T 1 2におけるキャリアの直交性を達成するための周波数オフセット又は訂正は、I S U上で決定することができる。これに対し

周波数オフセットは、キャリア、振幅及びタイミング再生ブロック222（図15）によって同期期間中HDTにおいて決定され、次いで、周波数オフセット調整コマンドが、それぞれHISU68及びMISU66のシンセサイザブロック195及び199を介してキャリア周波数の調整のためにISUに送出される。このようにして、もはや周波数誤差は上述したようにキャリア、振幅及びタイミング再生ブロック222によって検出されなくなるであろう。むしろ、そのようなダイレクトISU実施形態において、HISU68又はMISU66が下り信号からデジタル的に周波数誤差を評価し、その訂正信号が、伝送されようとしている上りデータに印加される。

HDT12は、同じ基本オシレータから全ての送信周波数及び受信周波数を抽出する。従って、ミキシング信号は全て、HDTにおいて周波数ロックされている。同様に、HISU68又はMISU66は同じ基本オシレータから全ての送信周波数及び受信周波数を

抽出する。従って、ISU上のミキシング信号もまた全て周波数ロックされている。しかしながら、HDTオシレータに対してISUオシレータには周波数オフセットが存在する。周波数誤差の量は（ISUから見て）ミキシング周波数の固定された割合となるであろう。例えば、ISUオシレータがHDTオシレータに対して周波数で10PPMオフし、下りISUレシーバにおける混合周波数が100MHzで、且つ、上りISUトランスミッタにおける混合周波数が10MHzであったとしたならば、ISUは、下りレシーバ上で1kHzの訂正を行わねばならないであろうし、上りトランスミッタ上で100Hzのオフセットを持つ信号を生成しなければならないであろう。このようにダイレクトISU実施形態においては、周波数オフセットは下り信号から評価される。

評価は、数値計算を行うデジタル回路、すなわちプロセッサを用いて実行される。同期チャンネル又はIOCチャンネルのサンプルは、システムの作動中にハードウェアで集められる。追跡用ループは、受信信号に対してデジタル的に混合されるデジタル数値オシレータを駆動する。このプロセスは、本質的にはHDTにロックされる信号を内部で抽出する。内部での数値ミキシングは周波数オフ

セットの要因となる。ISUにおいて下り信号へのロック処理が行われている間、周波数誤差の評価が引き出され、下り周波数を既知として分数周波数誤差が計算され得る。上りの受信信号をダウン変換するのに用いられるであろうHDTにおいてミキシング周波数が知られているものとして、ISU送信周波数に対するオフセットが計算される。この周波数オフセットは、例えば図13のコンバータ194によって信号をアナログ領域に変換する前にデジタル的にISU送信信号に印加される。従って、周波数の訂正はISU上で直接実行され得る。

図20及び図21を参照しながら、多相フィルタ構造を含むMCC上りレシーバアーキテクチャの狭帯域イングレスフィルタ及びFFT112について更に詳細に説明する。一般に、多相フィルタ構造は、多相フィルタ122及び124を含み、イングレスに対する保護を提供する。ISU100からの上りOFDMキャリアの6MHz帯域は、小グループのキャリア又はトーンに対してフィルタリングを提供する多相フィルタを通してサブバンドに分割される。もしイングレスが1グループのキャリア内のキャリアに影響を与えたならば、当該グループのキャリアのみが影響を受けることになり、他のグループのキャリアはそのフィルタリング特性によって保護されることになる。

イングレスフィルタ構造は、2つの並列的な多相フィルタのバンク122、124を有している。第1のバンクは、互いに重なり合わない17の異なる帯域を有し、帯域間にはチャンネル間隔が設けられている。図18には単一の多相フィルタバンクの振幅応答が示される。第2のバンクは、第1のバンクによって汜波されないチャンネルが第2のバンクによって汜波されるような量だけ第1のバンクからオフセットしている。従って、図19において単一の多相フィルタバンクの拡大された振幅応答に示されるように、汜波されたチャンネルの1つの帯域は、フィルタを通過しようとしている周波数ビン45-61に対応する中心キャリアを持つ周波数ビン38-68におけるチャンネルを含む。例えば、重なり合っているフィルタは周波数ビン28-44を通過させる。2つのチャンネルバンクは、2つのフィルタバンクの組み合わせによって544個のチャンネルの各々が受信されるように16個の周波数ビンだけ互いにオフセットしている。

図20を参照すると、イングレスフィルタ構造は、アナログデー

ィジタルコンバータ212からサンプルされた波形 $x(k)$ を受信し、次いで、複素ミキサ118及び120は、多相フィルタ122, 124に交互に信号を印加する。ミキサ118は一定の値を使用し、ミキサ120はオフセットを達成するような値を使用する。各ミキサの出力はそれぞれ対応する多相フィルタ122, 124に入力される。各々の多相フィルタバンクの出力は18個の帯域を有しており、各帯域は、16個の使用可能なFFTビンを含むか、又は、8kHzレートで16のキャリアをサポートする。帯域の1つは使用されない。

多相フィルタ122, 124の各帯域出力は、4つのガードサンプルを含む8kHzフレーム毎に36のサンプルを含み、高速フーリエ変換(FFT)ブロック126, 128に入力される。FFTブロック126, 128によって実行される第1の動作は、4つのガードサンプルを除去し、時間領域での32個のポイントを残すことである。ブロックにおける各FFTの出力は32個の周波数ビンであり、このうち16個はフィルタリングを提供する他のビンと共に用いられる。FFTの各出力は互いに重なり合うように形成される。図20に示されるように、キャリア0-15は上のバンクのFFT#1によって出力され、キャリア16-31は下のバンクのFFT#1によって出力され、キャリア32-48は上のバンクのFFT#2によって出力され、以下、同様にして出力される。

多相フィルタ122, 124はそれぞれ、当業者には知られているような標準の多相フィルタ構造であり、図21の構造によって示される。入力信号は、1秒当たり5.184メガサンプル、すなわち1フレーム当たり648サンプル、でサンプルされる。次いで、その入力18のファクタによって(18サンプルのうち1つが保持される)処理が施され、288kHzの有効なサンプル率が得ら

れる。この信号は、 $H_{0,0}(Z) \sim H_{0,15}(Z)$ とラベル付けされた有限インパルス応答(FIR)フィルタに供給される。各フィルタは幾つかのタップ、それぞれ好適には5つのタップを有している。当業者には認識されるように、タップの数は変えることが可能であり、本発明の範囲を制限するものではない。フィルタから

の出力は18ポイント逆FFT130にされる。変換後の出力は、4つのガードサンプルを含む8KHzフレームに対して36サンプルであり、上述したようにFFTブロック126及び128に供給される。FFTのトーンは好適には9KHzの間隔で設定されており、情報レートは、1シンボル当たり4つのガードサンプルが割り当てられている場合に1秒当たり8キロシンボルである。各多相フィルタからの17の帯域はFFTブロック126, 128に印加され、上述したように544個のキャリアの処理及び出力が行われる。上述したように、1つの帯域、すなわち18番目の帯域は使用されない。

上り及び下りのレシーバアーキテクチャにおけるイコライザ214(図15)及び172(図11)は、ケーブルプラントにかかるグループ遅延の変化を相殺するために設けられている。イコライザは、環境の変化に起因する位相及びゲイン又は振幅の変動を追跡し、それによって、十分に正確な追跡を維持しながら緩慢に適応することができる。内部イコライザ動作が図23に一般的に示されているところの各イコライザ172, 214の係数360は、FFT112, 170の解像度に対するチャンネル周波数応答の逆数を表している。下りの係数は、各チャンネルが同じ信号パスを通して進行しているが故に高度に相関がとられており、これに対し上りの係数は、個々のDS0+sが多対点トポロジーにおいて遭遇する変わりやすいチャンネルに起因して相関がとられていない。チャンネル特性は多様であるが、イコライザは、上りレシーバ又は下りレシーバに対し

て同じ動作を行う。

下りのイコライザは、IOCチャンネルのみに対して追跡を行い、それによってISUにおける計算の必要性を少なくすると共に、ペイロードチャンネルにおける前処理の必要性を無くしている。なぜなら、IOCチャンネルは常に伝送されているからであり、これについては以下に記述される。但し、上りのイコライザについては、DS0+及びIOCチャンネルベースでイコライズ処理が必要とされる。

イコライザの係数を更新するのに用いられるアルゴリズムは、32QAM群上で動作する時に幾つかの局所的な最小値を含み、4重の位相的にあいまいな状態

を受ける。更に、上りにおける各DSO+は、別々のISUから発することができ、それによって独立した位相シフトを持つことができる。この問題を軽減するために、データ伝送に先立って各通信の開始が固定のシンボルプリアンプを知らせるのに必要とされるであろう。但し、IOCチャンネルはこの必要性から除外される。なぜなら、IOCチャンネルはイコライズされないし、またそのプリアンプはスクランブルされ得ないからである。伝送の時点で、HDT12が、ISUの初期化及び活性化の間確立されている正確な周波数ロック及びシンボルタイミングをまだ有しており、且つ、連続して利用し得る下りのIOCチャンネル上で同期を維持するであろうことは知られている。

プリアンプの最初の部分は、イコライザがそのプロセス状態を認識することを必要としている。3つの状態があり、サーチ、獲得及びトラッキングのモードが含まれている。サーチモードは、チャンネル上の電力の量に基づいている。トランスミッタアルゴリズムは、使用されていないFFTビンにゼロ値を設定し、その結果として、その特定の周波数で電力は伝送されなくなる。レシーバでは、イ

コライザは、それはFFTビンに電力が無いことに基づくサーチモードであると決定する。

初期化され活性化されたISUに対して伝送が始まると、イコライザは、信号の存在を検出し、獲得モードに入る。プリアンプの長さはおよそ15シンボルである。イコライザは、そのプリアンプに基づいてイコライズ処理を変える。初期の位相及び振幅の訂正は大きいであろうが、その後の係数の更新によってそれほど意味はなくなるであろう。

獲得が終わると、イコライザは、更新レートを最小レベルに低減したままでトラッキングモードに入る。トラッキングモードは、電力の損失が一定期間中チャンネル上で検出されるまで続く。次いで、そのチャンネルは、使用されないが初期化され且つ活性化された状態となる。イコライザはもはや追跡を行わず、この時、レシーバは調整されつつあり、また係数は更新されない。係数は、以下に記述するように、チャンネルをモニタするための信号対ノイズ検出器305(図15)によってアクセスされ使用されてもよい。

イコライズ処理のために、I/Q成分が、FFT、例えばFFT112, 180の出力端でバッファ内にロードされる。当業者には明らかなように、イコライザの構造についての以下の記載は、上りレシーバのイコライザ214に関するものであるが、下りレシーバのイコライザ172にも同様に適用され得る。イコライザ214は、バッファから時間領域でのサンプルを抽出し、一度に1つの複素サンプルを処理する。次いで、処理された情報はそこから出力される。図23は当業者には明らかであるべきスタティック制御アルゴリズムよりも小さいイコライザアルゴリズムの基本構造を示す。主な同期パスは、乗算器370での複素数と選択されたFFTビンからの値との乗算を行うことである。次いで、その出力はシンボル量

量子化ブロック366において量子化され、格納テーブルから最も近いシンボル値とされる。量子化された値(ハード決定)は、シンボル対ビットコンバータ216によってデコードされビットに変換される。回路の残りの部分は、イコライザの係数を更新するのに用いられる。量子化されたシンボル値とイコライズ処理されたサンプルとの間の誤差が加算器364で計算される。この複素誤差は乗算器363によって受信サンプルに乘じられ、その結果は乗算器362によって適応係数分スケール処理されて、更新値を形成する。更新値は加算器368で元の係数と加算され、新たな係数値となる。

第1実施例の動作

好適な実施例において、HDT12の各MCCモデム82のための6MHz周波数帯域は図9Aに示すように割り当てられる。MCCモデム82は6MHz帯域全体について送受信を行なうが、ISUモデム100(図6)はそれらの特定の用途に対して最適化された6MHz帯域に割り当てられたキャリア又はトーンの総数よりも少ない数のものを終端し発生する。上り及び下り帯域の割り当ては好適には対称である。MCCモデム82からの上り6MHz帯域は5~40MHzスペクトル内にあり、下り6MHz帯域は725~760MHzスペクトル内にある。各6MHz帯域には、電話ペイロードデータの転送、ISUシステムの運用及び制御データ(10C制御データ)の転送、及び上りと下りの同期化のような特定の動作をサポートするために3つの領域がある。OFDM

周波数帯域における各キャリア又はトーンは振幅及び位相変調されて以前に記述した複雑な信号点配置を形成する正弦波からなる。OFDM波形の基本シンボル速度は8kHzであり、6MHz帯域内に全部で552のトーンがある。次の表1は各種のトーンに対する好適な変調形式及び帯域幅割り当ての要約である。

表 1

帯域割当	トーン又はキャリアの数	変調	容量	帯域幅
同期帯域	24トーン（各終縁部の2周期トーンと各終縁部の10ガードトーン）	BPSK	n/a	216kHz
ペイロードデータ	480（240DSO+チャンネル）	32QAM	19.2Mbps	4.32MHz
IOC	48（20データチャンネルまたは24IOCチャンネルのそれぞれに2）	BPSK	384Kbps	432kHz
帯域間ガード	各終縁部の残り	n/a	n/a	1,032MHz （各終縁部において518kHz）
複合信号	552	n/a	n/a	6.0MHz

送信後及び受信前の選択的濾波を可能にするためにスペクトルの各終縁部にガードバンドが設けられる。総計で240の電話データチャンネルが帯域内に含まれ、それは19.2Mbpsの正味データ速度を収容する。この容量は将来の加入者増を考慮して設計されたが、それによって中央局へのユーザの集中を達成するために十分なサポートが維持された。冗長性と多数のHISUに配置された狭帯域レーバに対する通信サポートを提供するために多数のIOCチャンネルが帯域内に散在する。IOCのデータ速度は16Kbps（1秒あたりに8kHzのフレームのシンボル速度のBPSKトーンが2つ）である。實際上、10ペイロードデータチャンネルあたりに1つのIOCが設けられる。単一のIOCチャンネルしか見ることができないHISUのようなISUはそのIOCチャンネルが損なわれたら強制的に再同調される。しかしながら、MISUのように、複数のIOCチャンネルを見ることができるISUは最初に選んだものが損なわれても別のIOCチャンネルを選択することができる。

同期チャンネルは冗長化のために帯域の終縁部において二重化され

、同期チャネルが他の使用チャネルと干渉しないことを確保するために使用可能なキャリアの本体部から離れている。同期チャネルについては以前に説明したが以下にさらに説明する。同期チャネルは電話ペイロードチャネルへの干渉の影響を減らすためにもその様なチャネルよりも低いパワーレベルで運用される。このようにパワーを低くすれば、同期チャネルとペイロード電話チャネルの間に用いられるべきガードバンドを小さくできる効果も得られる。

1つの同期チャネル又は冗長化した複数の同期チャネルは電話チャネルから離すのではなくその内部に設けることも可能である。それらが電話チャネルと干渉しないようにするため、同期チャネルを低シンボル速度を使って設けることも可能である。例えば、電話チャネルが8KHzのシンボル速度であれば、同期チャネルを2KHzのシンボル速度にすれば良く、それに加えてパワーレベルを低くしても良い。

ISU100は図9Dに示すように全体の6MHzスペクトルの集まりのうちサブバンドを受信するように設計される。例として、HISU68は好適には利用可能な522チャネルのうち22チャネルのみを検出する。このような実現方法は主として電力あたりのコストを削減する技術である。受信されるチャネルの数を削減することにより、サンプル速度及び関連の処理要件は劇的に減少し今日の市場にある普通の交換部品で達成することができる。

与えられたHISU68はHISU受信周波数の点でペイロードデータチャネルのうち最大10個のDS0の受信に制限されている。残りのチャネルはガード区間として使用される。さらに、コストあたりの電力の要件を減らすため、周波数合成の刻みは198KHzに制限され、それによってHISUの同調範囲は8チャネルセグメントに制限される。図9Dに示すようにHDT12によるHISU68の制御のために各HISU68が常に

1つのIOCチャネルを見るようにIOCチャネルが設けられる。

MISU66は図9Dに示すように13のサブバンド又は利用可能な240のDS0のうちの130のDS0を受信すべく設計される。同様に、効率的な周波数合成の実現のために同調の刻みは128KHzに制限される。これらはHISU68及びMISU66に対して好適な値であり、ここに特定された値の多くは添付の請求項に定義される発明の範囲

又は精神を変更することなく変更可能であることは当業者にとって明らかなことである。

当業者に公知の如く、6 MHz 以下の帯域幅におけるチャンネル間の動作をサポートする必要がある。当業者に明らかなようにシステムのソフトウェア及びハードウェアの適切な変更により、この様な再構成は可能である。例えば、2 MHz システムについては、下りにおいて、HDT12は帯域全体の部分集合の範囲のチャンネルを生成する。HISUは本来狭帯域であり2 MHz 帯域内に同調することができる。130チャンネルをサポートするMISUは2 MHz 帯域よりも広い範囲の信号を受信する。それらはハードウェアの変更によりフィルタの選択性を低下させる必要がある。80チャンネルのMISUは2 MHz システムの制約の中で動作することができる。上りにおいては、HISUは2 MHz 帯域内の信号を生成し、MISUの送信部は生成される情報を狭帯域に制限する。HDT12においては、入り口における汩波によって帯域信号エネルギーに対して十分な選択性が得られる。狭帯域システムは2 MHz 帯域の端部に同期帯域を必要とする。

以前に記述したように、下り情報の検出のためのシステムの初期化のための信号パラメータの収集は下り同期チャンネルを使って達成される。ISUはそのような下り情報の検出のための周波数、振幅及びタイミングの下り同期を確立するためにキャリア／振幅／タイミング再生ブロック 166を使用する。下り信号は1対多接続を構成し

OFDM波形は固有の同期的態様で単一の経路で ISUに到達する。

上り方向においては各ISU100は HDT12がISU100に送信を許可する前に上り同期化の過程を通して初期化され活性化される必要がある。ISUに対する上り同期化の過程は異なる ISUからの波形が HDT12において結合されて統合された波形になる役割を果たす。上り同期化の過程は、その一部が以前に説明されたが、種々のステップを含んでいる。それらは、ISU送信レベル調整、上りマルチキャリアシンボルの整列化、キャリア周波数の調整、周回遅延の調整を含んでいる。この様な同期化は6 MHz 帯域動作の獲得の後に行なわれる。

一般に、レベル調整に関して、HDT12はISU100から受信した上り伝送の信号強

度の測定値を校正し、ISU100送信レベルをすべてのISUが容認可能な閾値内にあるように調整する。レベル調整はシンボルの整列化及び経路遅延の調整の精度を最大にするためそれらに先行して行なわれる。

一般に、シンボルの整列化はMCCモデム82及びISUモデム101によって実現されるマルチキャリア変調の手法にとって必須の要件である。伝送の下り方向においては、ISU100において受信されるすべての情報は単一のCXMU56によって生成されるので、各マルチキャリア上で変調されたシンボルは自動的に位相が揃っている。しかしながら、MCCモデム82受信機レシーバアーキテクチャにおけるシンボルの整列化はHFC分散ネットワーク11の多対1性及びISU100の経路の不均一な遅延のために変化する。受信の効率を最大にするため、すべての上りシンボルは狭い位相マージン内で整列化されなければならない。このことは、異なるISUから上りで受信されるすべてのチャンネルのシンボル周期がそれらがHDT12に到達する時点で揃うように調節可能遅延パスを各ISU100に設けることにより達成される。

一般に、周回遅延の調整はシステムにおいてHDTネットワークイ

ンターフェース62からすべてのISU100まで及びすべてのISU100からネットワークインターフェース62へ戻るまでが等しくなるように行なわれる。このことはシグナリングマルチフレームの完全さがシステム全体で確保されるために必要である。電話伝送部に対するすべての周回処理はHFC分散ネットワーク11自身における信号伝播に関連する物理的遅延を除いて予測可能な遅延を有している。HDT12から近い物理的距離にあるISU100はHDT12から最大の距離にあるISUよりも短い周回遅延を持つであろう。経路遅延の調整はすべてのISUの転送システムに等しい周回伝播遅延を持たせるべく実現される。これによりシステム内で転送されるDSIチャンネルについてのDSIマルチフレームの整列化もまた維持され、そのDSIに関連する音声サービスについての整列化に関する帯域内チャンネルシグナリングまたはロブドビット(robbed-bit)シグナリングを維持する。

一般に、キャリア周波数調整はキャリア周波数の間隔がキャリアの直交性を維持するように達成されなければならない。直交整列化においてマルチキャリアがMCCモデム82で受信されないならば、マルチキャリア間の干渉が起きている可能

性がある。この様なキャリア周波数調整はシンボルタイミング又は振幅の調整の場合と同様な形で達成することができるかまたは以前に説明したように ISU上で実現することができる。

初期化の過程において、ISUに電源が投入されたとき、ISU100ほどの下り 6 MHz 周波数帯域を受信すべきかに関する知識を持っておらず初期化の動作ステップのために 6 MHz 帯域を獲得する必要がある。ISU100が動作のための 6 MHz 帯域の獲得に成功するまで、それはその下り周波数帯域の位置を決めるために“走査”の手法を実施する。ISU100 の CXSUコントローラ 102のローカルプロセッサは 62.5乃至850MHzの範囲内どこかのデフォルトの 6 MHz 受信周波数帯域

から開始する。ISU100は各 6 MHz 帯域において一定期間、例えば 100ミリ秒間待つてそのISU100に対するユニークな識別番号と一致する有効な 6 MHz 獲得コマンドを探す。その様なユニークな識別子は ISU機器のシリアル番号の形式またはそれに基づく形式をとることができる。その 6 MHz 帯域に有効な 6 MHz 獲得コマンドがなければ、CXSUコントローラ 102は次の 6 MHz 帯域を探し、その様な過程が繰り返される。この様にして、さらに以下に説明するように、HDT12はISU100に対して周波数受信のためにどの 6 MHz 帯域を使用すべきか及び上りの周波数送信のためにどの帯域を使用すべきかを告げることができる。

上記に説明したような ISUの初期化及び活性化の過程、及びトラッキングまたは追跡同期化について以下にさらに説明する。この説明はCXSUコントローラ 103と共にMISU66を使用して書かれているが、等価な制御ロジックで実現された任意のISU100に等しく適用することができる。コアックスマスタカードロジック (CXMC) 80はそのシェルフコントローラユニット (SCNU) 58に指示されて特定のISU100を初期化し活性化する。CXMC80は ISU指定番号をその機器に対する機器シリアル番号またはユニークな識別番号に関連付ける。製造過程から出荷された ISU機器で同一のユニーク識別子を持つものは2つとない。そのときのシステムデータベースにおいてそのISU100が一度も初期化され活性化されたことがなければ、CXMC80は初期化され活性化されるISU100のために或る個人識別番号(PIN)コードを選択する。このPINコードはCXMC80内に格納され、そのISU100とのすべての通信

のたの“アドレス”となる。CXMC80は各 ISU識別番号と、ISU機器に対するユニークな識別子と、PINコードとの間の参照テーブルを維持管理する。CXMU56に関連する各ISU100はユニークな PINアドレスコードの割り当てを有する。1つの PINアドレスコ

ードは、HDTがすべての初期化され活性化されたISU100へメッセージを送ることを許す、すべての ISUに対する同報的な性格のために保持される。

CXMC80は MCCモデム82による認識メッセージをそれが送信する6MHz帯域のすべてのIOCチャンネルを介して送信する。そのメッセージは、初期化され活性化されるべき ISUに割り当てられた PINアドレスコード、ISU100において ISUの初期化及び活性化が行なわれるべきであることを示すコマンド、機器シリアル番号の様な ISU機器に対するユニークな識別子、及びCRC(Cyclical redundancy checksum)を含んでいる。そのメッセージは或る周期で周期的に送られる。この周期は有効な識別メッセージを監視している ISUがすべての下り6MHz帯域を走査できる最大の時間である。その周期は例えば50ミリ秒であり、ISUがいかに早く自己を認識し得るかに影響する。CXMCは1度に1つ以上の ISUについて同期させようとはしない。或る最大制限時間を超えた後にも ISUが応答しないならば、ソフトウェアタイムアウトが働く。このタイムアウトは ISUが同期機能を達成するために必要な最大制限時間以上でなければならない。

CXMC80による周期的な伝送の間、ISUはその下り周波数の位置を決定するために走査の手法を実施する。CXSUのローカルプロセッサは625乃至850MHzの範囲内のどこかのデフォルトの6MHz受信周波数帯域から始める。ISU100は最初の6MHzの同期チャンネルを選択し一定時間後に同期にずれがあるかを試す。同期はずれが依然としてあれば2番目の同期チャンネルを選択し一定時間後に同期はずれがあるかを試す。同期はずれが依然としてあれば ISUは次の6MHz帯域上の同期チャンネルの選択を再開する。或る周期チャンネルにおいて同期はずれがないとき、ISUはIOCを含む最初のサブバンドを選択して正しい識別メッセージを探す。そのユニークな識別子と一致す

る正しい識別メッセージが見つかったら、PINアドレスコードが適切なレジスタにラッチされる。第1のサブバンドに正しい識別メッセージがなければ11番目のサブバンドのような中間のサブバンドが選択され、ISUは再び正しい識別メッセージを探す。再びメッセージが正しくなければ ISUは他の6 MHz 帯域上で再開する。ISUは1つのサブバンドにおいてCXMUの伝送時間の少なくとも2倍に等しい期間、例えば前述したように伝送時間が50ミリ秒であるとき 100ミリ秒間、正しい識別メッセージを探す。初期化及び活性化コマンドはISU100においてユニークなコマンドである。その理由はISU100はそのコマンドに応答するために PINアドレスコードの一致は必要とせず、有効なユニークな識別子と CRCの一致があれば良いからである。しかしながら、MCCモデム82によりCXMC80から送られる初期化及び活性化コマンドは有効な PINアドレスコードの一致がないときにISU100が受信することを許された唯一のコマンドである。初期化されず活性化されていないISU100が或る IOCチャンネル上で MCCモデム82によるCXMC80からの初期化及び活性化コマンドと、ユニークな識別子に一致するデータと、正しい CRCとを受信すると、ISU100の CXSU102はそのコマンドとユニークな識別子とともに送られてきた PINアドレスコードを格納する。このときから、ISU100は、再び活性化されて新しい PINアドレスコードを与えられる場合を除くことは勿論であるが、その正しい PINアドレスコードまたは同報アドレスコードによってそれをアドレス指定するコマンドに対してのみ応答する。

ISU100がそのユニークな識別子に一致するものを受け取った後、ISU100は、上り送信のためにどの6 MHz 帯域を使うべきか及びISU100が使用すべき上りの IOCチャンネルのためのキャリア又はトーンの指定をISU100に告げる PINアドレスコードを伴った上り周波数帯域

コマンドを受け取る。CXSUコントローラ 102はそのコマンドを解釈して応答するための正しい上り周波数帯域のためのISU100の ISUモデム 101を正しく活性化する。一旦 ISUモデム 101正しい6 MHz 帯域を獲得すると、CXSUコントローラ 103は ISUモデム 101へ或るメッセージコマンドを送って上りの同期を可能にする。HDT12の MCCモデム上りレシーバアーキテクチャのキャリア、振幅、及びタイミ

ング再生ブロック 222を使用する分散化ループは、振幅、キャリア周波数、シンボル整列化、及び経路遅延を含む上り伝送の様々な ISUパラメータをロックするために使用される。

図16はこの分散化ループを包括的に記述している。新しいユニットがケーブルに掛けられると、HDT12はケーブルに掛けられた ISUに対して、他のISU100に対して排他的な上り同期モードに入るように指示する。HDTは新しい ISUに関する情報を受け取り、加入者 ISUユニットに対して種々のパラメータについての下りコマンドを与える。ISUは上りの送信を開始し HDT12は上り信号にロックする。HDT12は調節されるべきパラメータに関するエラーインジケータを引き出し、加入者 ISUに対してそのパラメータの調整を命令する。エラーの調整はISUの送信のためのパラメータが HDT12にロックされるまで処理が繰り返される。

より特定すれば、ISU100が動作のための6 MHz 帯域を獲得した後、CXSU102はISUモデム 101へ或るメッセージコマンドを送り、ISUモデム 101は図9に示すようなスペクトル割り当ての最初の同期帯域における同期チャンネル上に同期パターンを送る。図9に割り当てられたようにパイロードデータチャンネルから離れている上り同期チャンネルは、同期チャンネルの1つが損なわれても上り同期化が達成できるように、初期及び冗長化同期チャンネルの双方を含んでいる。

MCCモデム82は有効な信号を検出し ISUからの受信信号に対して

振幅レベルの測定を行なう。同期パターンはCXMC80に対してISU100が活性化及び初期化及び周波数帯域コマンドを受け取り上り同期化を行なう準備ができていることを示す。振幅レベルは所望の基準レベルと比較される。CXMC80はISU100の送信レベルを調整すべきか否か及びその調節量を決定する。レベル調整が必要であれば、CXMC80は下り IOCチャンネル上にメッセージを送信してISU100の CXSU102に ISUモデム 101の送信のパワーレベルを調整するように指令する。CXMC80はISU100からの受信パワーレベルのチェックをし続け、ISU100によって送信されるレベルが容認できるものになるまでISU100へ調整コマンドを出す。振幅は ISUにおいて以前に議論したように調整される。初期の同期チャンネルを使って或る回数だけ振幅調整を繰り返しても振幅が平衡に達しないならば、または信号の存在が検出

されないならば、同じ処理が冗長化同期チャンネル上で行なわれる。初期及び冗長化同期チャンネルを使って或る回数だけ振幅調整を繰り返しても振幅が平衡に達しないならば、または信号の存在が検出されないならば、ISUはリセットされる。

ISU100の送信レベルに調整が完了し安定化したら、CXMC80とMCCモデム82はキャリア周波数ロックを行なう。MCCモデム82はISU100によって送信されたキャリア周波数を検出しISU100からの受信信号に対して相関処理を行なってISUからのすべての上り送信のマルチキャリアの直交整列化を行なうために必要なキャリア周波数の誤差量を計算する。MCCモデム82はISUについて周波数の整列化を達成するために必要なキャリア周波数のエラー調整の量を示すメッセージをCXMC80へ戻す。CXMC80はMCCモデム82により下り10Cチャンネル上にメッセージを送ってCXSU102へISUモデム101の送信周波数を調節するように指令し周波数がOFDMチャンネル間隔に対する或る許容範囲内になるまでその処理が繰り返される。このような調整は少なくとも

シンセサイザブロック195(図13及び図14)によりなされる。周波数ロック及び調整が前述のようにISUについて達成されたら、この周波数調整方法は使われない。

直交性を達成するため、CXMC80とMCC82はシンボル整列化を行なう。MCCモデム82はISUモデム101によって送信される8KHzフレームレートで変調された同期チャンネルを検出しすべての異なるISU100からの上りISU送信に対してシンボル整列化を行なうに必要な遅延相関を計算するために受信信号に対してハードウェア相関処理を行なう。MCCモデム82は、すべてのシンボルがHDT12において同時に受信されるようにISU100をシンボル整列化するために必要な遅延調節量を示すメッセージをCXMC80へ戻す。CXMC80はMCCモデム82によって下り10Cチャンネルにメッセージを送ってCXMU103にISUモデム101の送信の遅延を調節するように指令し、この処理はISUのシンボル整列化が達成されるまで繰り返される。このようなシンボル整列化は少なくともクロックディレイ196(図13及び図14)によって調節される。シンボル整列化が平衡に達するまでに多数の繰り返しが必要であり、所定の繰り返し数内で平衡に達しなければISUは再びリセットされる。

シンボル整列化と同時に、CXMC80は経路遅延の調整を行なうために MCCモデム 82へメッセージを送る。CXMC80は MCCモデム 82により下り 10Cチャンネル上にメッセージを送って、ISUモデム 101がISU100のマルチフレーム(2 KHz)の整列化を示す同期チャンネル上に他の信号を送ることを可能にするようにCXSUコントローラへ指令する。MCCモデム 82はこのマルチフレーム整列化パターンを検出しパターンに対してハードウェア相関処理を行なう。この相関から、モデム 82は通信システムの周回経路遅延に合わせるために必要な付加的なシンボル周期を計算する。次に、MCCモデム 82は全体の経路遅延の

要求に見合うように付加しなければならない遅延量を示すメッセージをCXMC80へ戻し、CXMCは MCCモデム 82により下り 10Cチャンネル上にメッセージを送ってCXSUコントローラ 102に対して経路遅延調整値を含むメッセージを ISUモデム 101へ中継するように指令する。経路遅延が平衡に達するまでに多数の繰り返しが必要であり、所定数の繰り返し内で平衡に達しなければ、ISUは再びリセットされる。このような調整は図13及び図14の上り送信機アーキテクチャの表示ディスプレイバッファ“n”サンプル 192に見られるような ISUトランスミッタにおいてなされる。経路遅延及びシンボル整列化は同期化チャンネル上に送られる同一または異なる信号を使って同時に別々または一緒に行なわれる。

ISUが初期化され活性化されるまでは、ISU100は 480トーン又はキャリアのいずれにおいても電話データ情報の送信能力を持たない。初期化及び活性化が完了した後は、ISU100はOFDM波形内の送信に必要な範囲内にあることになり、ISUは送信が可能であることを通知され上り同期化が完了する。

ISU100がシステムに対して初期化され活性化された後、OFDM転送の要件が要求する範囲内に ISUが校正された状態を保つために追跡及び同期化またはトラッキングが周期的に行なわれる。追跡処理は要素の値の温度ドリフトを考慮して実現される。ISU100が長い期間使われていなかったものであれば、ISUは同期チャンネルに同調され前述の上り同期化処理に従って上り同期パラメータを更新することが要求される。そうではなくて ISU最近使われたものであれば追跡同期化またはトラッキングは 10Cチャンネル上で行なうことができる。このシナリオのもとでは

、図17に一般的に示されるように、ISU100は IOcチャンネルを通して信号を出すことが HDT12から要求される。HDT12はその信号がOFDM波形内のチャンネルに要求される範囲内に

あることを検証する。そうでなければ ISUはその様な誤ったパラメータを調整することが要求される。さらに、長い使用期間中に ISUは上り同期化パラメータの更新を目的として IOcチャンネルまたは同期化チャンネル上に信号を送ることを HDT12から要求される。

下り方向においては、IOcチャンネルはISU100への制御情報を転送する。変調形式は好適には差分符号化BPSKであるが、下り変調の差分特性は必須ではない。上り方向においては、IOcチャンネルは HDT12への制御情報を転送する。IOcチャンネルは上り方向へデータを送る際の等化器に関連した遅延時間を軽減するために差分BPSK変調される。制御データはバイトバウンダリ(500 μ sフレーム)で挿入される。任意の ISUからのデータは IOcチャンネル上で非同期で転送することができ、従って衝突が起こる可能性がある。

衝突の可能性があるため、上り IOcチャンネル上の衝突の検出がデータプロトコルのレベルで行なわれる。そのような衝突を取り扱うプロトコルは例えば ISUによる指数関数的なバックオフを含んでいる。HDT12が送信エラーを検出するとき、特定の時間だけ待った後 ISUが IOcチャンネル上に上り信号を再送するように再送コマンドがすべての ISUへ同報通信される。待ち時間は指数関数に基づく。

当業者は HDTから指令されたように ISUがシンボルタイミングを調節するためのシンボルタイミンググループのみを使って多対1伝送を許しつつ上り同期化を実現しうることを認識している。上り同期化のための周波数ループについては、ISUにおいて IDTにロックしていない高品質の局部自走発振器を使用すれば、省略可能である。さらに、ISUの局部発振器は外部基準にロックさせることもできる。振幅ループは HDTにおけるシンボル整列化を達成する上で本質的ではない。

通信システム10における呼処理は、HDT12からISU100への電話伝

送のためのシステムのチャンネルを加入者に割り当てる過程を伴う。本発明に係る

通信システムは集線処理を含まない呼処理技術例えばTR-8サービスとTR-303サービスのような集線処理を含むものの双方をサポートすることができる。集線処理は ISUにサービスしているチャンネルの数以上のサービスを要求する ISU端末が存在するとき起こる。例えば、システムに対して1000の加入者線端末がある一方でそのような加入者へサービスを提供するために割り当てることができるペイロードチャンネルの数が 240のみであるときである。

TR-8の運用のように集線処理が必要でないとき、6 MHz スペクトル内でチャンネルが静的に割り当てられる。したがって、チャンネルの再割当のみがチャンネルの監視に関して以下にさらに議論される。

一方、TR-303サービスを提供するもののような集線処理を提供するための動的に割り当てられたチャンネルについては、HDT12は HFC分散ネットワーク11上での電話データの転送のためのオンデマンドなチャンネル割当をサポートする。そのような動的なチャンネル割当は HDT12とISU100の間の直信のための IOCチャンネルを利用して達成される。ISU100の加入者への着呼に対してまたはISU100の加入者から発呼に対してチャンネルが動的に割り当てられる。以前に議論したように HDT12のCXMU56は HDT12とISU100の間の呼処理情報を担う IOCチャンネルを実現する。特に、IOCチャンネル上には次の呼処理メッセージが存在する。それらは少なくとも ISUから HDTへの回線捕獲またはオフフックメッセージと、ISUから HDTへの回線開放またはオンフックメッセージと、HDTと ISUの間の使用可能及び使用不能回線アイドル検出メッセージを含んでいる。

HFC分散ネットワーク11上の加入者への呼については、CTSU54はその加入者線端末に関連するCXMU56へメッセージを送り、CXMU56へ HFC分散ネットワーク上で呼の転送のためのチャンネルを割り当て

るように指示する。CXMU56は呼が意図しているISU100によって受信されるべき IOCチャンネル上にコマンドを挿入する。そのコマンドは割り当てられたチャンネルについてISU100へ警告するために CXSU102へ適切な情報を提供する。

ISU側の加入者からの発呼の際には、各 ISUは回線捕獲のためにチャンネルを監視する責任がある。回線捕獲が検出されたとき、回線の使用を開始するためにIS

U100はこの変化を PINアドレスコードとともに上り 10C動作チャネルを使って HDT12の CXMU56へ伝えなければならない。CXMU56が回線捕獲メッセージを正しく受け取ったら、CXMU56はこの内容をさらに呼を設定するために変換網へ必要な情報を提供する CTSU54へ転送する。CTSU54はチャネルが利用可能か否かをチェックし、ISU100で発せられた呼にチャネルを割り当てる。ISUからの呼を完成するためのチャネルが同定されたら、CXMUは回線捕獲を要求している ISU100へ下り 10Cチャネルを介してチャネルを割り当てる。加入者がオンフック信号を戻したとき、適切な回線アイドルメッセージが上りで HDT12へ送られ、HDT12はそのチャネルが再び TR-303サービスをサポートするために割り当てることができるようにその情報を CTSU54へ提供する。

アイドルチャネル検出はさらに他の技術を利用しているモデムにおいても達成しうる。ISU100の加入者がデータパイロードチャネルの使用を終了した後、MCCモデム82は以前に割り当てたチャネルがアイドル状態であることを決定することができる。アイドル検出は複素（I及びQ成分）シンボル値を出力する FFTの結果を調べる等化器214(図15)による等化処理を利用して達成しうる。等化に関して以前に議論したようにエラーが計算され、それは等化器の係数を更新するために使用される。代表的には、等化器が信号を獲得し有効なデータ検出されるとき、誤差信号は小さい。信号が終了すると

誤差信号は増加し、このことは S/N モニタ 305で監視することができ、それによって使用されているパイロードデータチャネルの終了またはチャネルアイドル状態が決定される。そのようなシステムの運用が集線処理をサポートしているときこの情報はアイドルチャネルの割り当てのために利用できる。

等化処理は、チャネル監視に関して以下にさらに詳細に説明するように未割当または割当済のチャネルにノイズによる障害があるかどうかを決定するためにも利用できる。

電話伝送システムはいくつかの態様でチャネルのノイズからの保護を提供する。狭帯域のノイズは外部源から伝送に結合して侵入した狭帯域信号である。OFDM波形内に位置するノイズ信号は全体の帯域をオフラインにする可能性がある。ノ

イズ信号はOFDMキャリアと直交しておらず（もしくはその可能性が高く）、最悪の場合、すべてのOFDMキャリア信号と十分なレベルで干渉しほとんどすべての DSSS+をその性能が最小ビットエラーレート以下に劣化する程度までに障害を与える。

1つの方法は周波数帯域上でのノイズの位置を特定する干渉検知アルゴリズムを含むデジタル的に同調可能なノッチフィルタを設けることである。位置が特定されれば、OFDM波形からノイズを除去するフィルタを提供すべくフィルタが更新される。フィルタは基本モデム動作の一部ではないが、それらを同調により除去する目的で劣化したチャネルの特定を必要とする。干渉の結果として失われたチャネルの量はノイズが実際にいかに多くのチャネルに障害を与えたかを決定するための周波数領域におけるビットエラーレート特性に応じて決定される。

図15の MCC上り受信機レシーバアーキテクチャのノイズフィルタ及びFFT112に関して以前に議論したような他のアプローチは多相フ

ィルタ構造である。システムに対して十分なノイズ保護を提供する一方で、フィルタに関するコストと電力は HDT12に吸収される。すなわち、ISU100における電力消費は増加しない。図20及び図21に関して以前に議論したように好適なフィルタ構造は2つの互い違いになった多相フィルタを含んでいる。1つのフィルタの使用も明らかに含まれているが、その場合いくつかのチャネルが減ることになる。フィルタ/変換の対はフィルタと復調処理を単一のステップに結合する。多相フィルタがもたらす特徴のいくつかは狭帯域のノイズに対して受信帯域を保護することができることと、上り伝送において計測可能な帯域の利用を可能にすることである。これらのアプローチにより、ノイズがいくつかのチャネルを利用不能にするならば、HDT12はノイズを避けるために ISUに対して異なるキャリア周波数上で上り送信をするように指令することができる。

少なくともデジタル的に同調可能なノッチフィルタと多相フィルタの使用を含むノイズ保護に対する上記のアプローチはマルチキャリア転送を利用する1対1システムにも等しく適用可能である。例えば、単一の HDTへ転送する単一の MISUはこの技術を使用できる。さらに、単方向の多対1転送もキイズ保護のために

この技術を利用できる。

さらに、チャンネル監視及びそれに基づく割当または再割当もまたノイズを避けるために使用される。外部変数は与えられたチャンネルの品質に悪い影響を与える可能性がある。これらの変数は無数にあり、電磁干渉から光ファイバの物理的損壊までである。光ファイバの物理的損壊は通話リンクを切断し、チャンネルの切換では避けることはできない。しかしながら、電氣的な干渉を受けたチャンネルは干渉がなくなるまで避けることができる。干渉がなくなった後、チャンネルは再び使用することができる。

図28において、チャンネル監視方法は、劣化チャンネルの使用を検出し、それを回避するために用いられる。チャンネルモニタ296は、ボードサポート(BSP)ソフトウェア298からのイベントを受信し、ローカルデータベースのチャンネル品質テーブル300を更新する。また、モニタ296は、割当て又は再割当てのためにメッセージを障害分離器302及びチャンネル割当て器304に送出する。チャンネルモニタへの基本入力は、パリティエラーであって上りDSO+チャンネルのハードウェアから得られる。DSO+チャンネルは、パリティ又は前述したチャンネルに挿入されるデータインテグリティビットを伴う10ビットのチャンネルからなる。特定チャンネルのパリティエラー情報は、生データとして使用され、そのチャンネルの品質ステータスに至る時間を通してサンプルされ、集積される。

パリティエラーは、チャンネルステータスを判断するため、PTOS、ISDN、DDS及びDSIを含む異なるサービスタイプの各々に対して2タイムフレームを使用して集積される。第1の集積ルーチンは、全てのサービスタイプに対し1秒の短い集積時間に基づいて行われる。第2のルーチンは、長い集積が行われ、表3に示すように異なる集積時間と監視期間とを要する種々のサービスに必要とされるエラービットレートとしての、従属サービスである。これらの2つの方法が以下で述べられる。

図29A、29B及び29Cには、基本の短い集積動作を述べている。CXMU56がチャンネルのパリティエラーを検出した時、パリティ割込みはそのパリティ割込み(図29A)より高い割込み優先レベルを設定することによってディセ

ーブルされる。もし、受信信号障害を示すモデムアラームが受信されたなら、パリティエラーはその障害状態が終了するまで無視される。従って、いくつかの障害状態はパリティエラー監視に取って代わる。そのようなアラーム

状態には、信号の消失、モデム障害、そして同期はずれが含まれる。もし、モデム障害が非アクティブなら、パリティカウントテーブルは更新され、図29Bに示すエラータイムイベントはイネーブルされる。

エラータイムイベントがイネーブルされた時、CXMU56のパリティエラーレジスタが10ミリ秒毎に読み出され、チャンネルモニタ296は1秒監視期間の後にエラーカウンターの集計モードに入る。一般に、エラーカウンタはチャンネル品質データベースを更新し、そしてどのチャンネルが再割当てを要求しているか決定するのに使われる。前記データベースのチャンネル品質テーブル300は各チャンネルの進行中の記録を含む。前記テーブルは、チャンネルに割当てられたカレントISU、監視の開始と終了、全てのエラー、先日、先週、過去30日のエラー、最後のエラーからの秒数、先日、先週、過去30日の重大エラー、そしてチャンネルに割り当てられたISDNのような現在のサービスタイプ、のカテゴリにおけるチャンネルの履歴を示す。

図29Aに示すように、パリティ割込みがディセーブルされてアクティブアラームが存在しなくなった後、パリティカウンタは更新され、そしてタイマーイベントはイネーブルされる。前記タイマーイベント(図29B)は上述したエラーを監視する1秒ループを含む。図29Bに示すように、1秒ループが経過しなければ、エラーカウンタは更新され続ける。それが経過した時にエラー集計がなされる。以下に示すように、前記1秒間に集計されたエラーは、割当てチャンネルの劣化若しくは障害を示す許容量を超えた場合にチャンネル割当て器304に通知され、ISU伝送は異なるチャンネルに再割当てされる。図29Cに示すように、再割当てが完了した時、割込み優先度はパリティより低く設定され、その結果チャンネル監視

が継続し、チャンネル品質データベースは実行されるアクションに応じて更新され

る。再割当てタスクは、エラータイマタスクから独立したタスクとして実行されてもよく、又そのタスクと結合して実行されてもよい。例えば、再割当て器304はチャンネルモニタ296の一部であってもよい。

図29Bのエラータイマタスクの別の実施例である図29Dに示すように、チャンネルは1秒経過前に障害と判断され得る。このことは、1秒間の最初の部分の間に劣化と判断されたチャンネルが、完全に1秒経過するのを待つことなく直ちに定義され再割当てされることを許容する。

再割当てに代えて、チャンネル上のイングレス(ingress)を克服するためにISUによる伝送パワーレベルを増加してもよい。しかしながら、1チャンネル上のパワーレベルを増加するなら、全体のパワーレベルを実質的に一定に維持するために少なくとも他の1チャンネルのパワーレベルを減少させなければならない。

全てのチャンネルが障害となった場合、障害分離器302はファイバの切断等の重大な障害が存在する可能性を通知される。もし、1秒間に集計されたエラーが割当てチャンネルが劣化していないことを示す許容値以下であるなら、割込み優先度はパリティ以下に設定され、エラータイムイベントはディセーブルされる。そのようなイベントはやがて終了し、前記チャンネルは再び図29Aに示すパリティエラーのために監視される。

上述した周期的なパリティ監視によって現われる2つの結果は、チャンネルの劣化を判断する1秒の監視期間に観測されるパリティエラーカウントに対応するビットエラー率を評価するのに重要である。第1はパリティ自体の性質である。ブロックエラー検出に用いられるデータフォーマットの一般的な使用において1つのエラープロ

ックは1ビットのエラーを示すと仮定している。しかしながら、実際にはそのエラーは多数のデータビットを表す。データトランスポートシステムの性質から、変調データに含まれるエラーは、そのデータをランダム化するものと考えられる。このことは、平均エラーフレームは4つのエラーデータビット(第9ビットを除く)から成ることを意味する。パリティでは奇数ビットエラーだけを検出するため、全エラーフレームの半分はパリティによって検出されない。従って、トラ

ンスポートインタフェースによって生じる各パリティ（フレーム）エラーは、8（データ）ビットのエラー平均を示す。第2に、各モニターされたパリティエラーは80フレームのデータ（10ms / 125μs）を表す。パリティエラーはラッチされるため全てのエラーは検出されるが、重複エラーは1つのエラーとして検出される。

チャンネルを再割当てする時を決定する基準としてビットエラーレート（BER）が使用され、 10^{-3} が選択される。従って、 10^{-3} を超えない1秒間のパリティエラー許容数を決定する必要がある。許容可能なパリティエラーを確立するために、各観測（モニター）されたパリティエラーによって表される予想フレームエラー数を予測する必要がある。モニタパリティエラーの数、モニタパリティエラー当たりの推定フレームエラー数、そしてフレーム（パリティ）エラーによって表されるビットエラー数を与えることで、予想ビットエラー率を導出することができる。

統計手法を使って、以下の仮定をする。

1. エラーはポアソン分散を有し、そして
2. モニタパリティエラーの数が全“サンプル”数（100）において小さければ（ < 10 ）、モニタパリティエラーレート（MPER）は平均フレームエラーレート（FER）を反映する。

モニタ（監視）パリティエラー（MPE）は、80フレームを表すため、前記仮定2は各パリティエラー“の裏にある”フレームエラー（FEs）数が80MPERに等しいということを意味する。すなわち、サンプル当たり10msの100パリティサンプルに対し、パリティエラー当たりの平均フレームエラー数は1秒間におけるMPEカウントの0.8倍に等しいことになる。例えば、もし3MPEが1秒間に観測されたなら、各MPEに対する平均FEの数は2.4である。所望のビットエラー率をサンプルサイズに掛けること、そしてフレームエラー当たりのビットエラーで割ることはそのサンプルの等価フレームエラー数を与える。FEの数は、またMPEの数とMPE当たりのFEの数との積に等しい。所望のBERを与えることにより、下式の解決策が決定される。

$$\left(\text{MPE} \frac{\text{FE}}{\text{MPE}} \right) = 0.8 \text{MPE}$$

以下に示すポアソン分散は、 $\text{MPE}(\chi)$ で表される所定のFE数の確立を計算するために使用される。上記仮定2は、 $\text{MPE}(\mu)$ 当たりの平均FE数に至るために使用される。

$$P(\chi) = \frac{e^{-\mu} \mu^{\chi}}{\chi!}$$

所望のビットエラー率は最大であるから、0から最大数までの χ に対する値が首尾よくポアソン式に与えられる。これらの確立の合計は各モニタパリティエラーに対して発生する χ フレームエラー以下の確立である。

ビットエラー率 10^{-3} そしてフレームエラー当たりのビットエラーが1及び8の結果を表2に示す。

表2: ビットエラー率確立

フレーム当たりのビットエラー	監視パリティエラー	最大フレームエラー/監視パリティエラー (χ)	平均フレームエラー/監視パリティエラー (μ)	BER < 10^{-3} の確率
	2	4	1.6	9.8%
8	3	3	2.4	7.8%
	4	2	3.2	3.8%
	8	8	6.4	8.0%
1	9	7	7.2	5.6%
	10	7	8.0	4.5%

この手法を使って、1秒集積期間中に検出された4個の監視パリティエラーの値も新チャンネルに対するISUの再割当てサービスの閾値として決定した。この結果は、フレームエラー当たり8ビットエラーの最悪ケースであり、しかしビットエラー率が 10^{-3} より良い3.8%の確立と仮定することによる。フレーム監視パリティエラー当たりのビットエラーと監視パリティエラー当たりの最大フレー

ムエラーとの積は、ビットエラーレート 10^{-3} から 64 でなければならない (64 K ビットで 64 エラー)。従って、エラータイムイベントでパリティエラーのサンプリングが 4 又はそれ以上の時、チャンネル割当て器はチャンネル劣化を通知される。もし、サンプルされた監視パリティエラーが 4 に満たない時は、割込み優先度をパリティより低く設定し、エラータイムイベントをディセーブルしてタイムエラーイベントを終了する。そのチャンネルは 27A のフロー図に示すように監視される。

以下では、チャンネルモニタ 296 のバックグラウンド監視ルーチン (図 30) によって実行される長い集積動作について述べる。前記バックグラウンド監視ルーチンは、短い集積 10^{-3} ビットエラー率より

も高品質を必要とするチャンネル品質の完全性を保証するのに用いられる。図 30 のフロー図が示すように、バックグラウンド監視ルーチンは、各サービスタイプの特定期間に動作し、チャンネル品質データベーステーブル 300 を更新し、バックグラウンドカウンタをクリアし、集積エラーが各サービスタイプで決められた許容範囲を超えたか否かを判断し、そして必要なら障害チャンネルのチャンネル割当て器 304 に通知する。

1 秒期間の動作中、バックグラウンドモニタはチャンネル品質データベーステーブルを更新する。前記チャンネル品質データベーステーブルの更新には 2 つの目的がある。第 1 の目的は、エラーフリーチャンネルのビットエラーレートとエラー秒データ数とを調整し、それらを品質の向上に反映させることである。第 2 の目的は、非常に低いエラーレベル (4 パリティエラー / 秒以下) のために短い集積時間再割当てとなる監視チャンネルの間欠エラーを集積することである。この範疇のチャンネルは、その BER と調整されたエラー秒データ数とを有し、そのデータに基づいて再割当てされる。このことは長い集積時間再割当てとして知られており、以下に各サービスタイプに対する長い集積時間再割当ての初期基準を示す。

表 3

サービス タイプ	最大 BER	集積 時間	エラー 秒	監視 周期
POTS	10^{-3}	1秒		
ISDN	10^{-6}	157秒	8%	1時間
DDS	10^{-7}	157秒	0.5%	1時間
DSI	10^{-9}	15,625 秒	0.04%	7時間

POTSサービスは、 10^{-3} 以上の高品質を必要としないため、劣化チャンネルは短い集積手法を用いて十分除去でき、長い集積は必

要としない。

あるサービスタイプの長い集積の一例として、バックグラウンドモニタをISDNトランスポートに使用するチャンネルと関連して述べる。前記チャンネルの最大ビットエラー率は 10^{-6} であり、集積時間に利用される秒数は157、許容可能な最大エラー秒数は157秒の8%、そして監視期間は1時間である。従って、どの1時間の監視期間においてもエラー秒の合計が157秒の8%より大きければ、チャンネル割当て器304にISDNトランスポートのチャンネル障害を通知する。

非割当て又は未使用チャンネルであるが初期化され活性化されているものは、TR-8のような非集中(non-concentration)サービスに対する再割当てのために使用され、又はTR-303のような集中サービスに対する割当てや再割当てのために使用されるかにより、それらが障害でないことを保証する監視が必要となる。チャンネルモニタ304は、非割当てチャンネルを監視するためバックアップマネージャルーチン(図31)を使用し、割当て又は再割当ての決定に用いられるエラーデータを集積するためにループに非割当てチャンネルを設定する。非割当てチャンネルがエラーとなった時に1時間はそれをISU100に割当てない。前記チャンネルが1時間のあいだアイドル(非割当て)を維持した後、チャンネルモニタは前記チャンネルをループバックモードに設定し、そのチャンネルが回復したか否かを検査する。ループバックモードにおいて、CXMU56は、初期化され活性化さ

れたISU100に対し、パリティエラーの短い又は長い集積を実行するのに十分な長さのチャンネルに関するメッセージを適宜送出するよう命ずる。ループバックモードにおいて、先に劣化したチャンネルが回復時間を経過し、それによってチャンネル品質データベースが更新されたか否かを判断することができる。ループバックモード以外では、そのようなチャンネルをパワーダウンすることができる。

上述したように、チャンネル品質データベースは再割当て又は割当てを許可するか否かの情報を含み、再割当て又は割当てはそれに用いられるチャンネルが劣化しないようになされる。さらに、前記チャンネル品質データベースの情報は、非割当てチャンネルが有効に割当てられるように品質に基づいて非割当てチャンネルをランク付けする利用のしかたも可能である。例えば、あるチャンネルは、PTOSに対して十分であり、ISDNに対しては十分でないとしてもよい。別に追加されたチャンネルは両者に十分としてもよい。前記追加されたチャンネルは、ISDNに使用されるがPTOSに使用されないものであってもよい。さらに、高品質な特定の待機チャンネルを配し、イングレスが非常に大きな時に、常に切り替えるべき1つのチャンネルを入手できるようにしてもよい。

さらに、図15に示すMCCモデム82の上りレシーバアーキテクチャのイコライザ214を利用した非割当て及び割当てチャンネルの両者に対し、信号対雑音比の評価が決定される。先に述べたように、初めにチャンネルが割当て可能なアイドルか否かを判断するのにイコライザが利用される。イコライザの動作中、イコライザの係数を更新すべくエラーが生成される。エラーの大きさはマッピングされ、信号対雑音モニタ305（図15）によって信号対雑音比（SNR）が評価される。また、未使用チャンネルはその帯域内に信号を有してはならない。従って、未使用のFFTビン(bin)内で検出された信号の変化を検出し、信号対雑音比の評価が決定される。信号対雑音比の評価は推定ビットエラーレートに直接関係するため、前記推定ビットエラーレートは障害又は正常なチャンネルの存在を判断するチャンネル監視に利用される。

よって、TR-8のような非集中サービスの再割当てのためループバックモー

ドで監視される非割当てチャンネル等を伴う非割当てチャンネルに対し、又はイコライザの利用によるSNR評価によって再割当てが実行される。同様に、TR-303のような集中サービスの割当て又は再割当てが、イコライザの使用によるSNR評価により決定された非割当てチャンネル等の品質に基づいて非割当てチャンネルに対して実行される。

チャンネル割当てに関し、チャンネル割当て器304のチャンネル割当て器ルーチンは、チャンネル品質データベースを検査し、要求されたサービスのためにどのDSO+チャンネルをISU100に割当てるかを決定する。チャンネル割当て器は、またISUのステータスとチャンネルユニットとをチェックし、要求されたサービスに対するサービス提供中のステータス及び適当なタイプを確認する。チャンネル割当て器は、チャンネル再割当ての柔軟性を許容すべくISU100における最適な帯域分散を維持する。

ISUs100、少なくともHISU、は、どの所定時間でもRF帯域部分だけでアクセスできることが好ましい。チャンネル再割当て器は、前記ISUのチャンネル使用を分散し、それによって帯域の一部が過負荷とならず、付加チャンネルの空きが生じないようにサービス中チャンネルの再割当てを回避する必要がある。

チャンネル割当て器304で使用されるプロセスは、各ISUタイプの同じ番号を6MHzスペクトルの各チャンネル帯域に割当てる。現在のISU帯域が満杯で且つ新たなサービスがそのISUに割り付けられた場合、もし必要ならISUで使用中のチャンネルを新たな帯域に移動させることができる。同様に、1つの帯域でISUが使用するチャンネルが劣化した場合、前記ISUは別のサブ帯域またはチャンネル帯域にチャンネルを再割当てすることができる。分散したI

OCチャンネルがHDT12とHISUとしてのHISUsとの間の通信を許可し続けるため、IOCチャンネルの1つはそのスペクトルにわたって分散される。一般に、最も長い低エラーレートの履歴を有するチャンネルが最初に使用される。そして、障害と判定されその後監視のために再割当てされたチャンネルは、最も長い期間中低いエラー状態で動作してきたチャンネルよりもその履歴が短いため、最後に使用される。

電話トランスポートシステムの第2の実施例

図24-27を参照して、OFDM電話トランスポートシステムの第2の実施例について説明する。図24は、6MHzスペクトル割当てを示している。6MHz帯域幅は、9つの個々のモデム226（図25）に対応して9チャンネル帯域に分割される。当業者なら、同一動作を結合することによってより少ないモデムが使用できることが分かる。各チャンネル帯域は、シンボル当たり5ビットからなる直交32アレイフォーマット（QAM32）で変調された32チャンネルを含んでいる。1つのチャンネルは、転送動作をサポートし、HDT12とISU100との間の通信データを制御するために割当てられる。このチャンネルは、BPSK変調を使用する。

トランスポートアーキテクチャについて、初めに下り伝送について述べ、次に上り伝送について述べる。

図25を参照して、HDT12のMCCモデム82のアーキテクチャについて述べる。下り方向において、シリアル電話情報と制御データがシリアルインタフェース236を介してCXC80から与えられる。前記シリアルデータは、復号器238によって復号化されてパラレルデータストリームとなる。前記パラレルデータストリームは、シンボルマッピングと高速フーリエ変換（FFT）機能を実行する32チャンネルモデム226バンクに与えられる。32チ

ャネルモデムは時間領域サンプルを出力し、それはシンセサイザ230によって駆動される1組のミキサ240を通過する。ミキサ240は、直交する1組の周波数帯域を生成し、各帯域は次にフィルタ／合成器228を通して濾波される。フィルタ／合成器228の集合出力はシンセサイザ242及びミキサ241によって最終送信周波数にアップコンバートされる。その信号は、フィルタ232によって濾波され、アンプ234によって増幅され、そして全てのノイズを除去するためにフィルタ232によって再び濾波される。前記信号は、電話トランスミッタ14を介してHFC分散ネットワーク上に結合される。

HFC分散ネットワーク11の下り終端部において、ISU100は図26に示す加入者モデム258を有する。下り信号は、同軸レグ(leg)30を通して0

D N 1 8 から受信され、完全な 6 M H z 帯域を選別するフィルタ 2 6 0 によって
濾波される。次に、前記信号は 2 つの部分に分離される。第 1 の部分はシステム
クロックに同期するための制御データとタイミング情報とを与える。第 2 の部分
は電話データを与える。電話データから分離して受信された制御データは、帯域
I S U の出力として先に言及している。B P S K 変調された帯域制御チャネルの
出力は、ミキサ 2 6 2 によって混合されてベース帯域となる。その信号は次にフ
ィルタ 2 6 3 によって濾波され、自動利得制御段 2 6 4 とキャリア位相を回復す
るコスタス(Costas)ループ 2 6 6 とを通過する。その信号はタイミングループ 2
6 8 に渡され、その結果タイミングは完全なモデム用として回復される。コスタ
スループの副産物である I O C 制御データは、I S U 1 0 0 の 3 2 チャンネル O F
D M モデム 2 2 4 に与えられる。下り O F D M 波形の第 2 の部分は、ミキサ 2 7
0 及び関連するシンセサイザ 2 7 2 によって混合されてベース帯域となる。ミキ
サ 2 7 0 の出

力はフィルタ 2 7 3 によって濾波され、受信に備える利得制御段 2 7 4 を通過す
る。そして、その信号は、3 2 チャンネル O F D M モデム 2 2 4 に渡される。

図 2 7 において、I O C 制御データは機能ブロック 2 7 6 によってハードリミ
ットされ、マイクロプロセッサ 2 2 6 に与えられる。O F D M 電話データは、ア
ナログ-ディジタル変換機 2 7 8 を通過し、それを記憶するファーストイン-フ
ァーストアウト・バッファ 2 8 0 に入力される。前記データの十分な情報量が記
憶された時に、前記データはマイクロプロセッサ 2 2 6 に与えられる。前記マイ
クロプロセッサは F F T の適用を含む復調プロセス要求を発する。マイクロプロ
セッサ 2 2 6 は、受信データと受信データクロックインタフェースを介して前記
受信したデータをシステムの空き部分に与える。高速フーリエ変換(F F T)エ
ンジン 2 8 2 はマイクロプロセッサとは別に実装される。しかしながら、当業者
が理解しているように、F F T 2 8 2 はマイクロプロセッサ 2 2 6 によっても実
行し得る。

上り方向において、データは送信データポートを介して 3 2 チャンネル O F D M
モデム 2 2 4 に与えられ、そしてマイクロプロセッサ 2 2 6 によってシンボルに

変換される。これらのシンボルは、FFTエンジン282を通過し、その結果ガードサンプルを含む時間領域波形は複合ミキサ284に与えられる。複合ミキサ284はその波形を混合して周波数アップコンバートし、その信号はランダムアクセスメモリ・デジタル-アナログ変換機286 (RAMDAC)を通過する。RAMDACは、サンプルがISU上りトランスミッタ (図26)のアナログ部へ与えられる前にそれを記憶するRAMを含む。図26を参照すると、上り伝送のOFDM出力は、フィルタ288によって濾波される。その波形は次にミキサ290を通

過し、シンセサイザ291の制御によって混合されて送信周波数までアップコンバートされる。前記信号はプロセッサ利得制御292を通過し、そこではその信号の振幅レベリングが上りパス上で実行される。前記上り信号は、ODN18へ至る同軸レグ30上に上り伝送する前に、最終選択を行う6MHzフィルタ294を通過する。

HDT12側の上り方向において、電話レシーバ16から同軸上で受信される信号はフィルタ244によって濾波され、増幅器246によって増幅される。直交周波分割多重された受信信号は、ミキサ248バンク及び関連するシンセサイザ250によって混合され、ベース帯域となる。ミキサ248の各出力は次にベース帯域・フィルタバンク252によって濾波され、各出力時間領域波形は32チャンネルOFDMモデム226の復号器に送られる。前記信号はFFTを通過し、そのシンボルはビットにマップバックされる。前記ビットはマルチプレクサ254によって多重化され、他のシリアルインタフェース256を介してCXMC56に与えられる。

本実施例で示したように、ISUは帯域ISUの出力であり、制御データと電話データの分離受信の利用はそのことを示す。さらに、スペクトルはチャンネル帯域に分離される。トランスポートシステムの関連クレームによって実現される種々の他の実施例は、ここで述べられた実施例を構築することで可能となる。1つの実施例において、少なくとも同期情報トランスポートするIOC制御チャンネル及び電話サービスチャンネル又はパスは、単一のフォーマットとして与えられる。H

DT12とISUs100との間のI OCリンクは16Kbpsで動作する4BPSK変調キャリア、全体として64Kbps、によって実現してもよい。各加入者は、第2の実施例のように簡易な分離トランシーバを備え、電話チャンネルから分離された

下りリンク上でそれに割り付けられたサービスチャンネルを継続して監視してもよい。このトランシーバは、サービスI OCに合わせるため調節された発振器を必要とするかもしれない。同様に、I OCチャンネルは6MHz帯域のチャンネル帯域を与え、そのチャンネル帯域は電話データとI OCチャンネルの直交キャリアを含んでもよい。前記I OCチャンネルはその直交キャリアの受信により分離されて受信される。

4BPSKチャンネルに代え、他の実施例では単一の64KbpsI OCチャンネルが提供される。この単一チャンネルは、そのシンボルレートがOFDMフレームネットワークの電話シンボルレートと一致しない。しかしながら、OFDM周波数構成の上に存在する。この単一の広帯域信号はISU100において、HDT12とISUsとの間のI OCリンクを常に可能とするより広い帯域レシーバを必要とする。単一チャンネルサポートでは、固定の基準発振器が使用可能であり、加入者ユニットにおけるどんな帯域部分の調節も必要としない。しかしながら、I OCチャンネルが狭帯域レシーバを考慮したスペクトルに分散される第1の実施例とは異なり、ISU100で広帯域レシーバを使用するには本実施例で要求されるパワーが増加する。

さらに他の実施例において、I OCリンクは、32OFDMチャンネルグループの各々について2つのI OCチャンネルを有してもよい。これによって各グループにおけるOFDMキャリアの数は32から34に増加する。各チャンネルグループは34OFDMチャンネルで構成してもよく、チャンネル帯域は8から10チャンネルグループを含んでもよい。このアプローチは、OFDM波形を利用するためHDT12によって与えられる基準パラメータにロックするのに狭帯域レシーバを使用可能とする。しかしながら、OFDMデータパスフ

フォーマットにおける制御又はサービス情報を与えなければならないという複雑性を付加する。なぜなら、加入者はどんなチャネルグループの1つにも調節できるが、エクストラキャリアに埋め込まれた情報は局側で追尾する必要があるからである。そのシステムはタイミング取得要求をサポートするために、本実施例において同期信号がOFDM波形終端から離れて配置されることを要求する。

本発明の多くの特徴は発明の詳細な構成及び機能と共に上述してあり、その開示は例証であって順序、形状、サイズ、構成部分、そして動作における様々なプロパティの変更は発明の要旨の範疇に含まれる。そして、クレーム内容は、その用語の広い一般的な意味によって最大限に拡張される。

【図1】

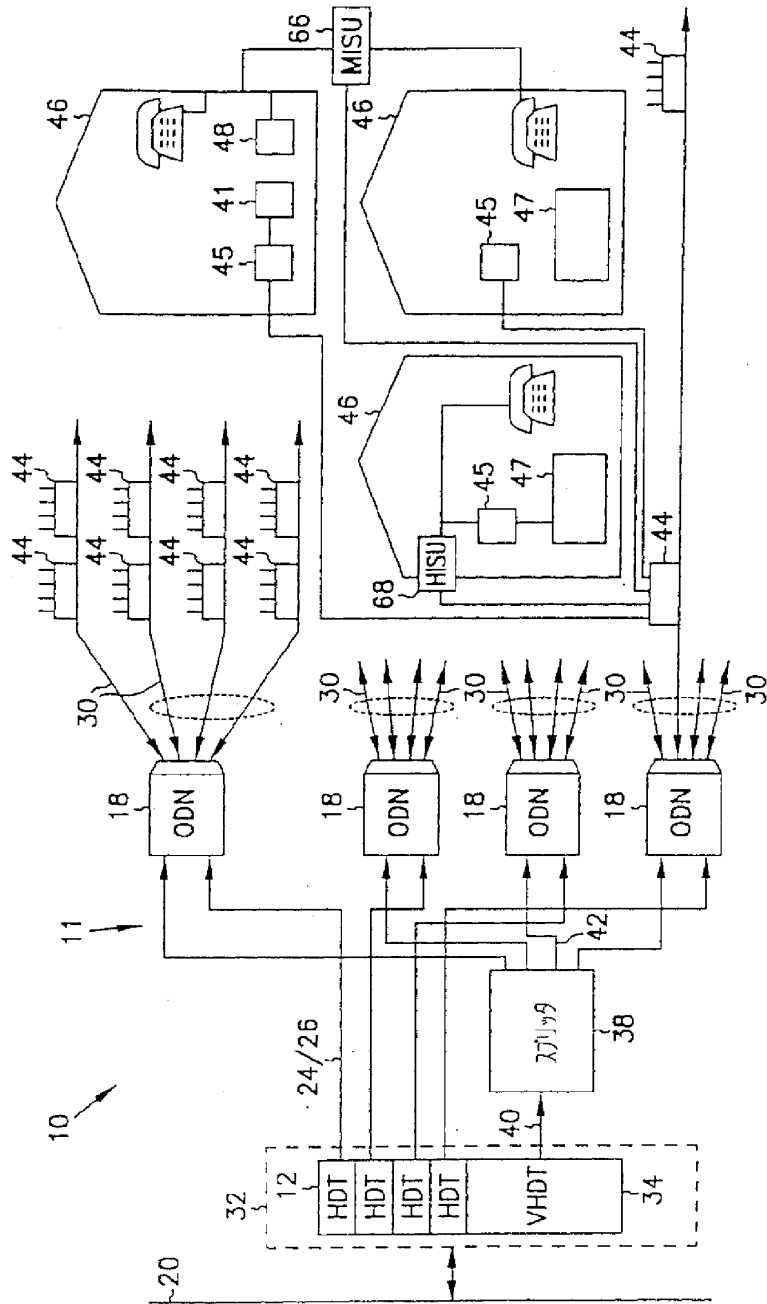

FIG. 1

【 図 2 】

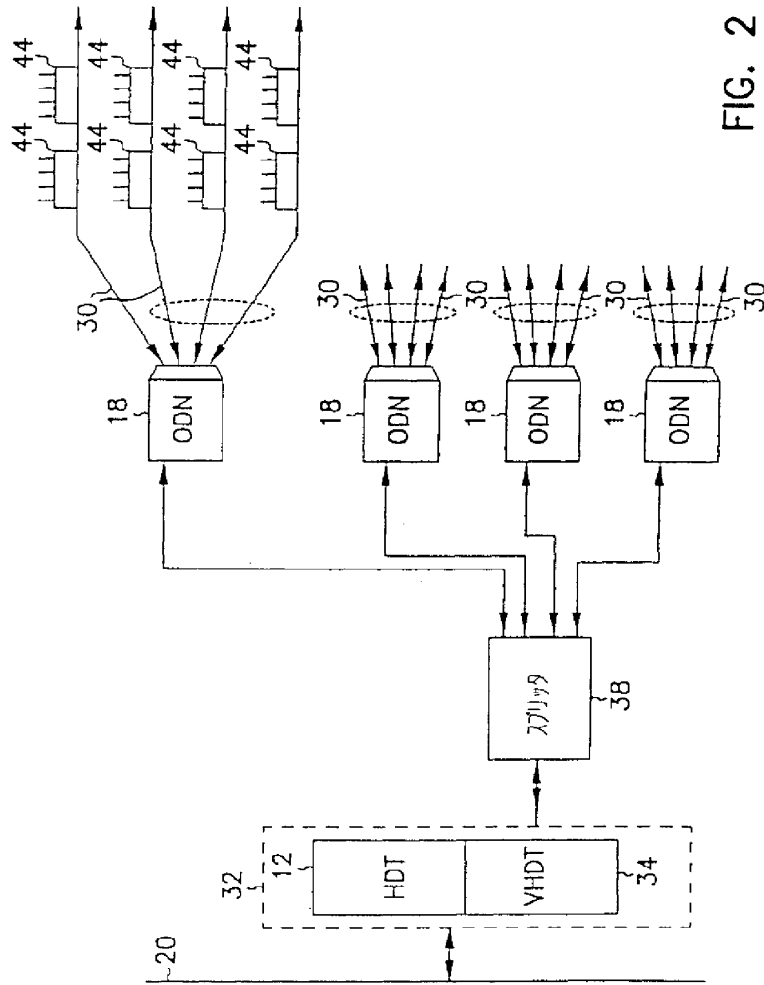

FIG. 2

【図3】

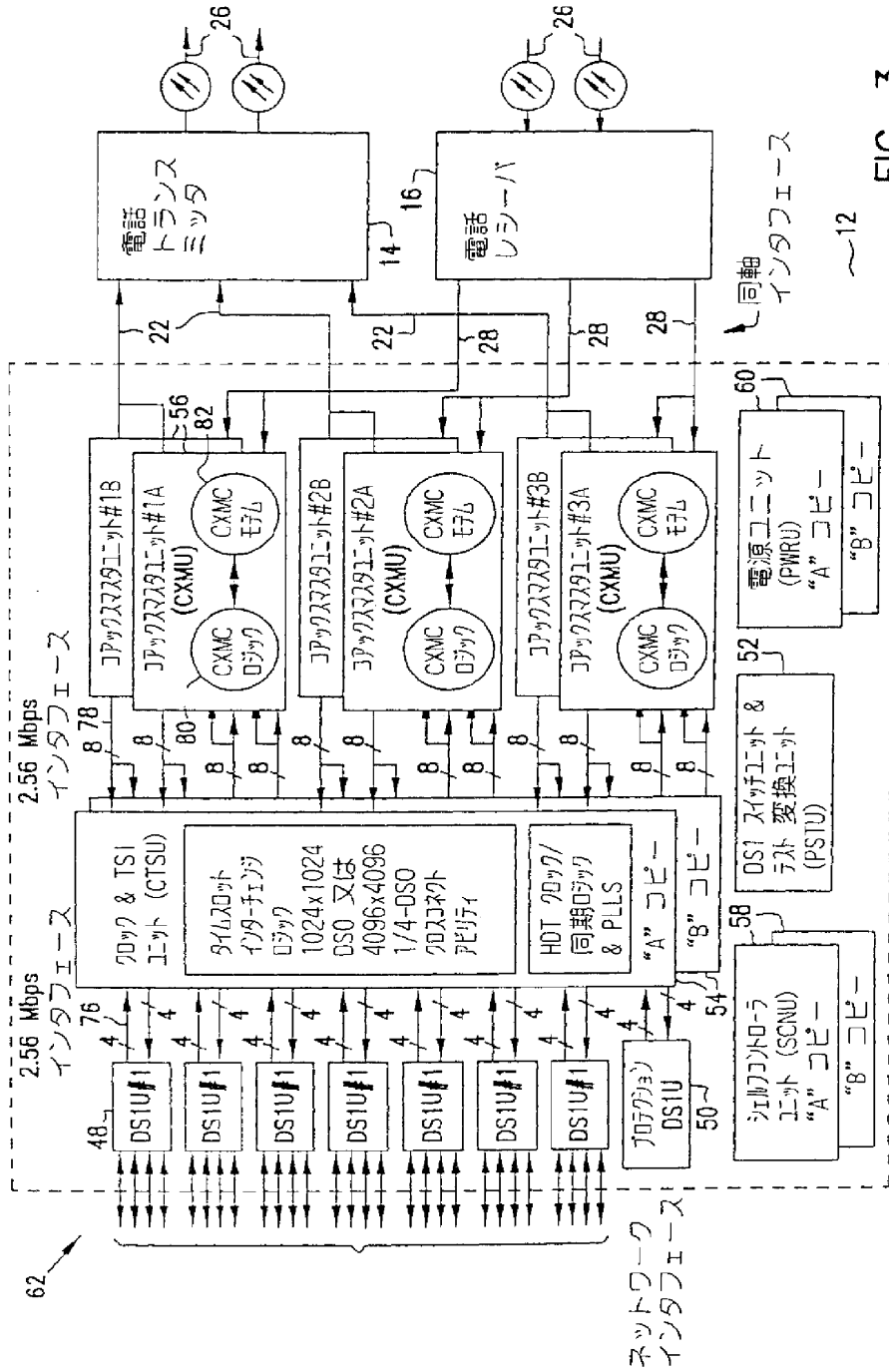

FIG. 3

【 図 4 】

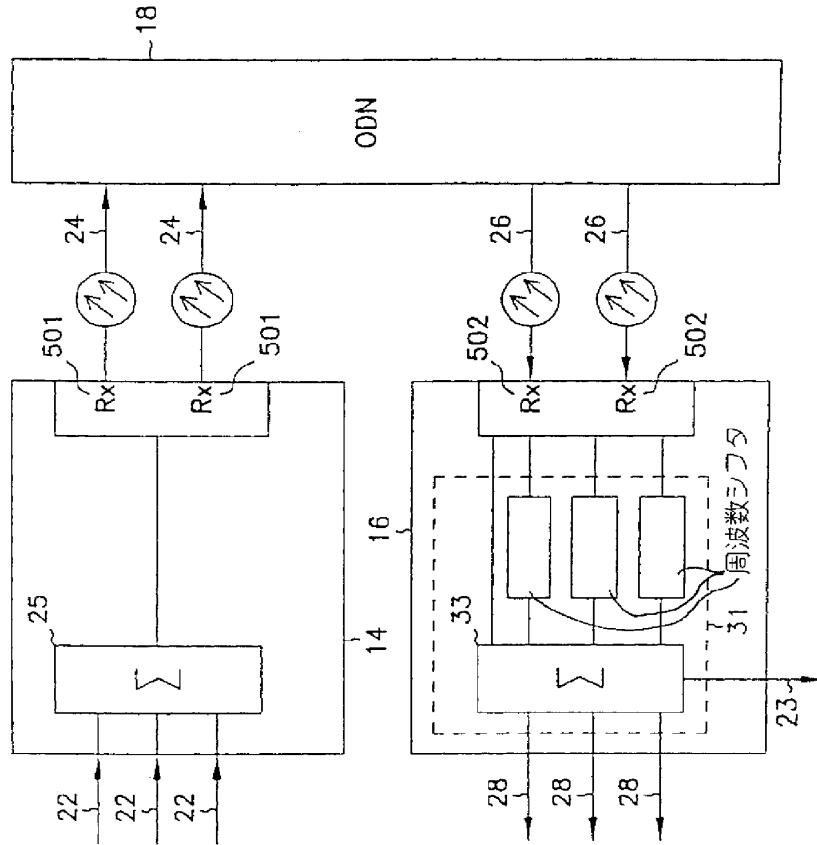

FIG. 4

【図5】

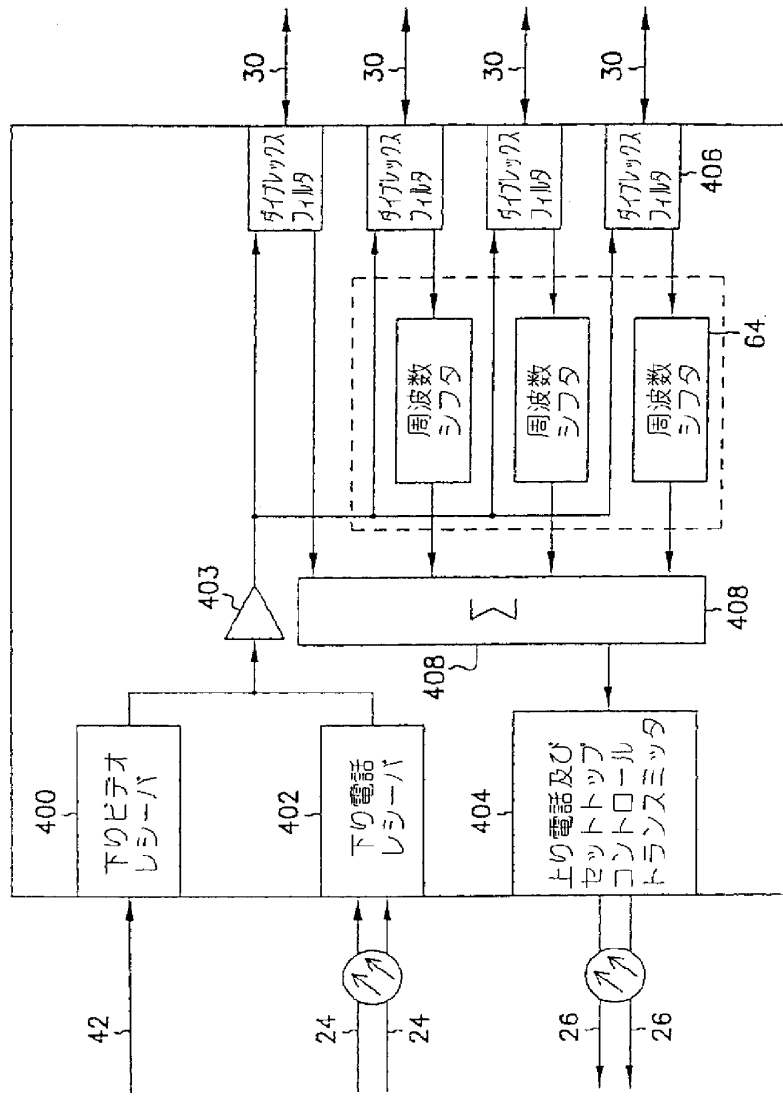

FIG. 5

【図6】

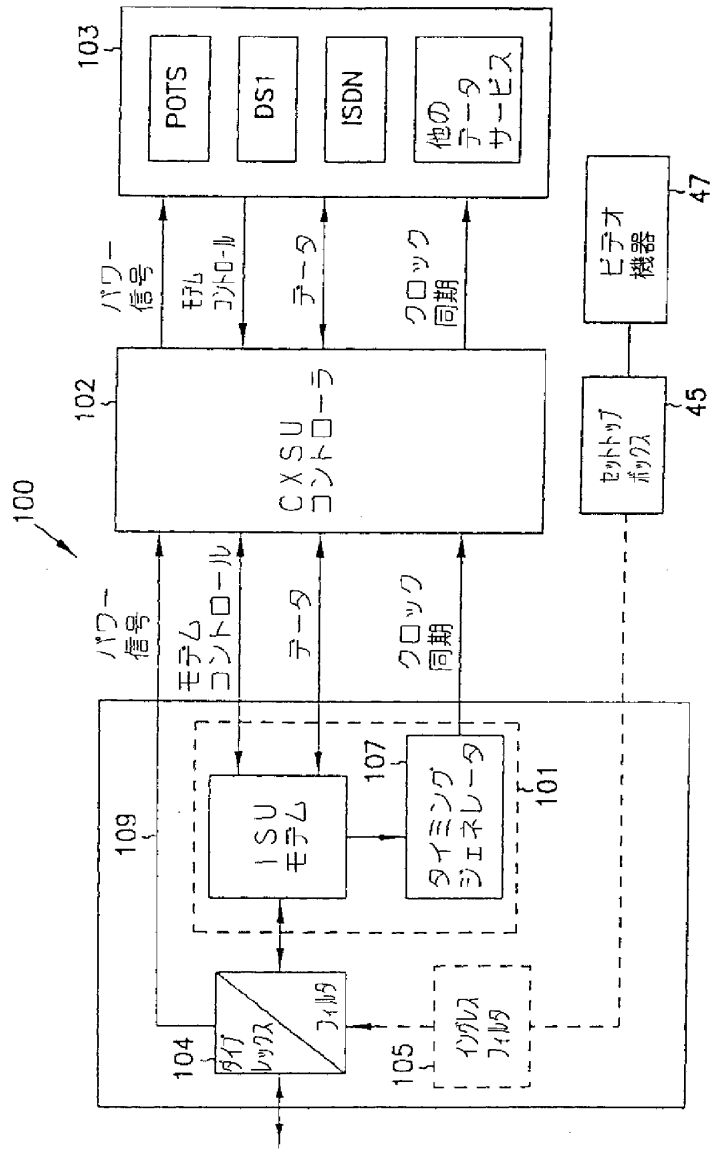

FIG. 6

【 図 7 】

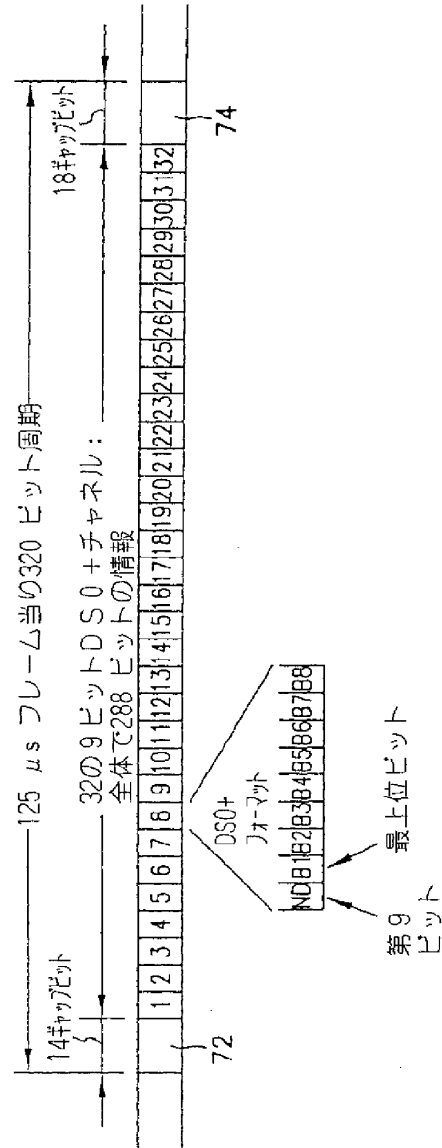

FIG. 7A

【 図 7 】

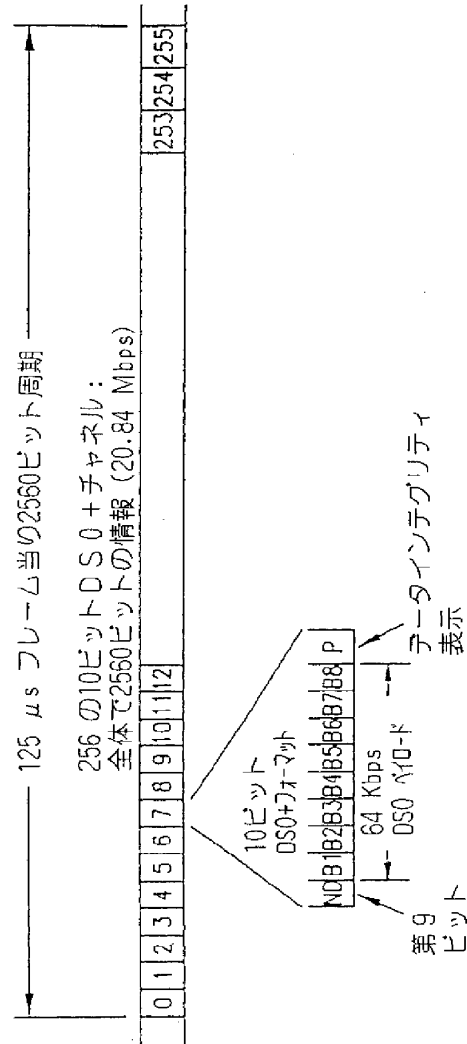

FIG. 7B

【 図 7 】

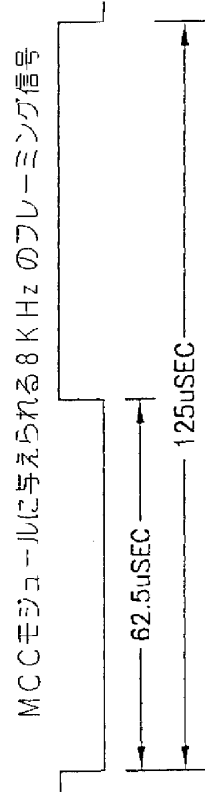

FIG. 7C

【図8】

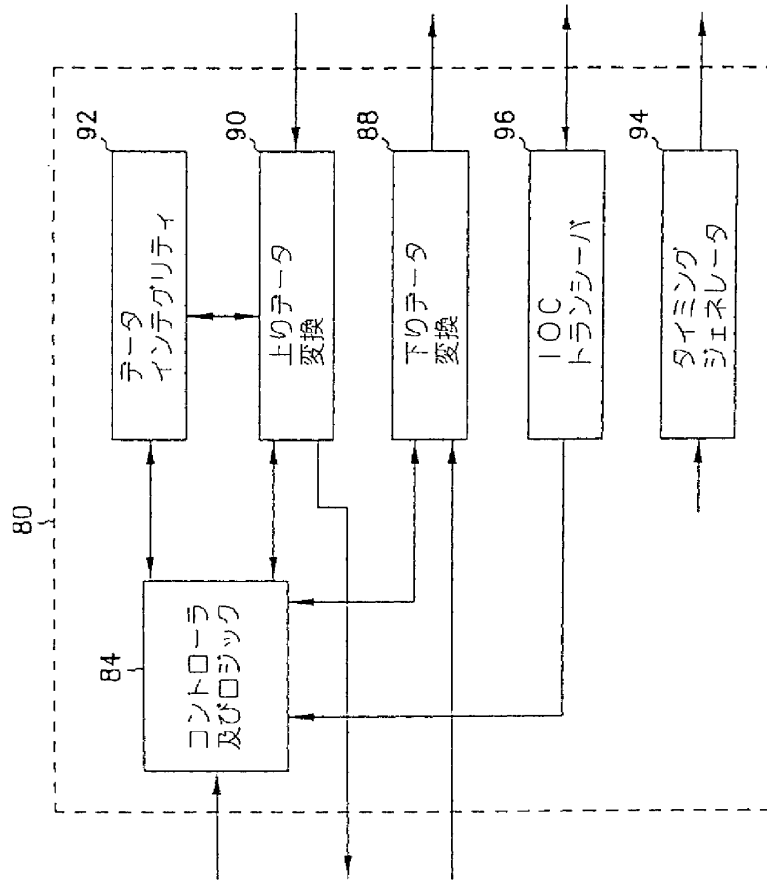

FIG. 8

【 図 9 】

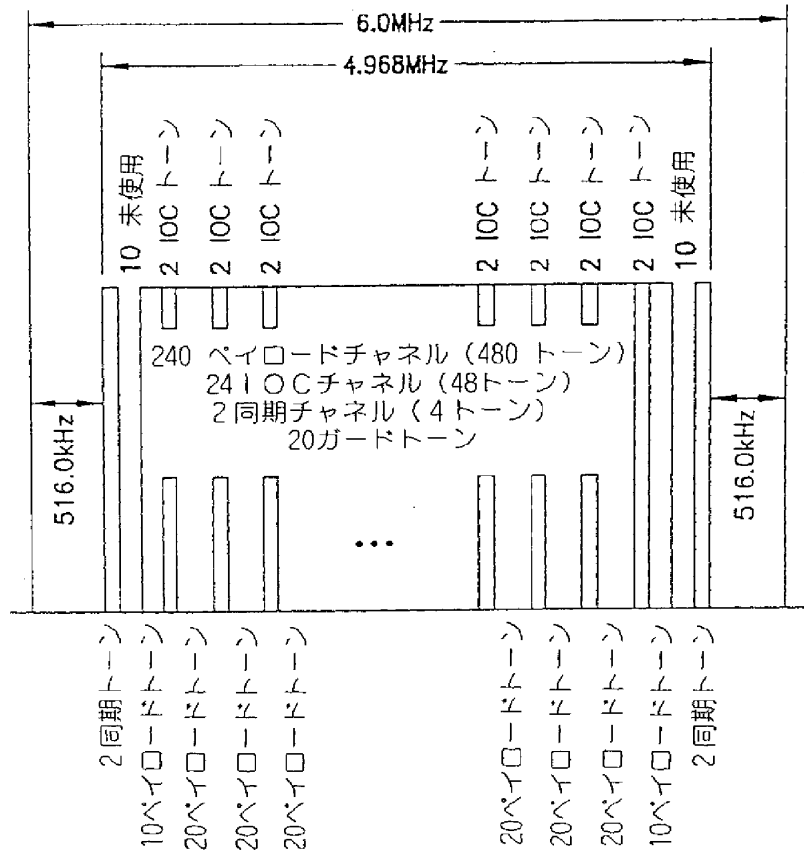

FIG. 9A

【図9】

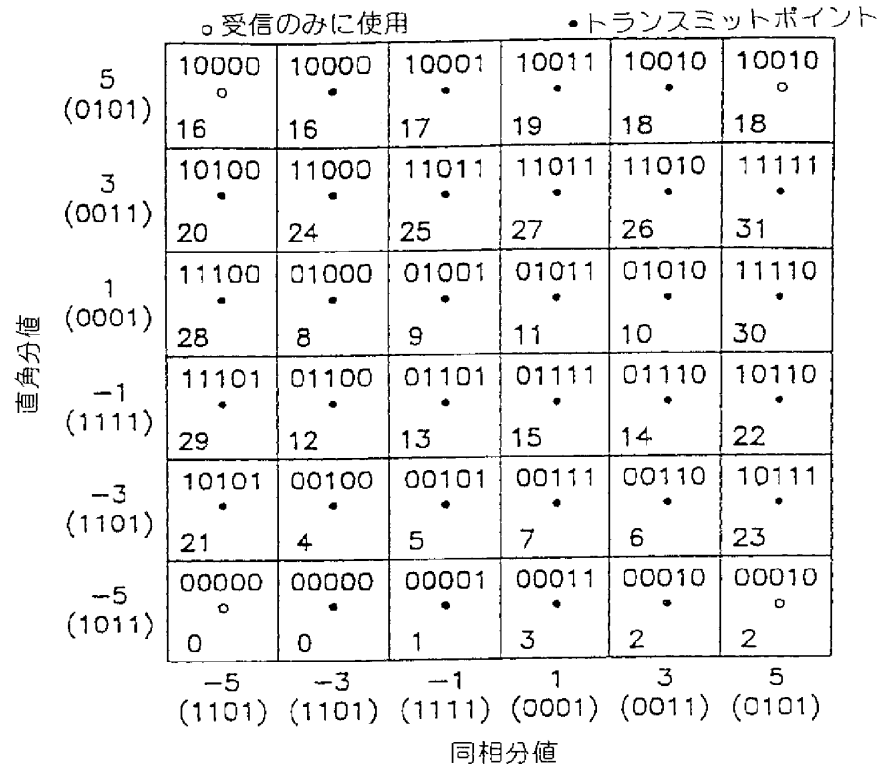

FIG. 9B

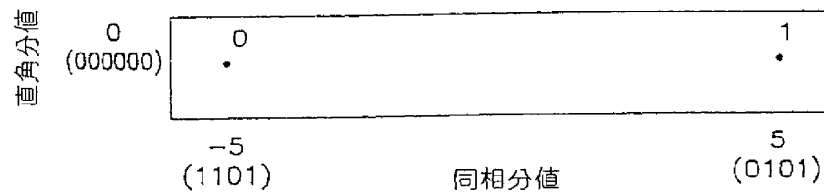

FIG. 9C

【 図 9 】

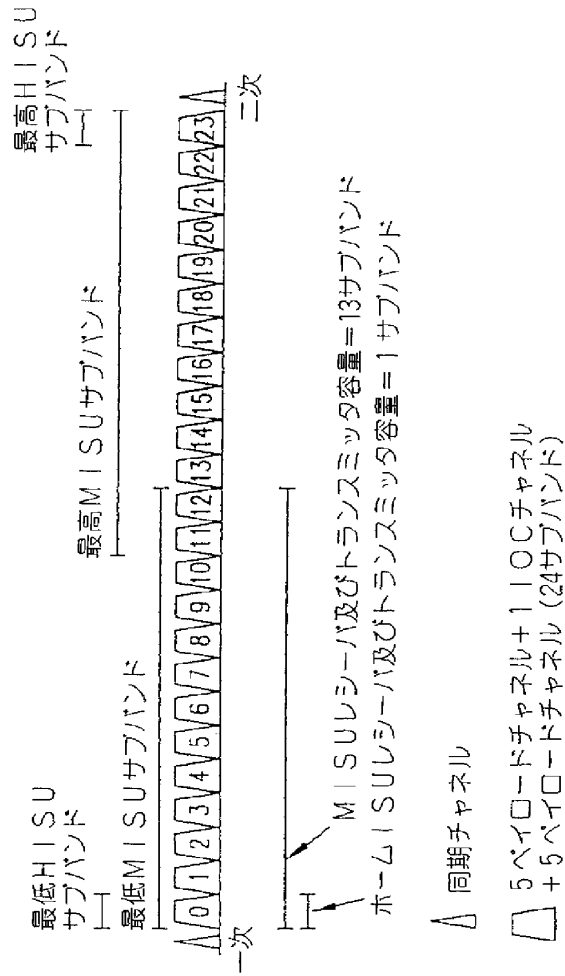

FIG. 9D

【図10】

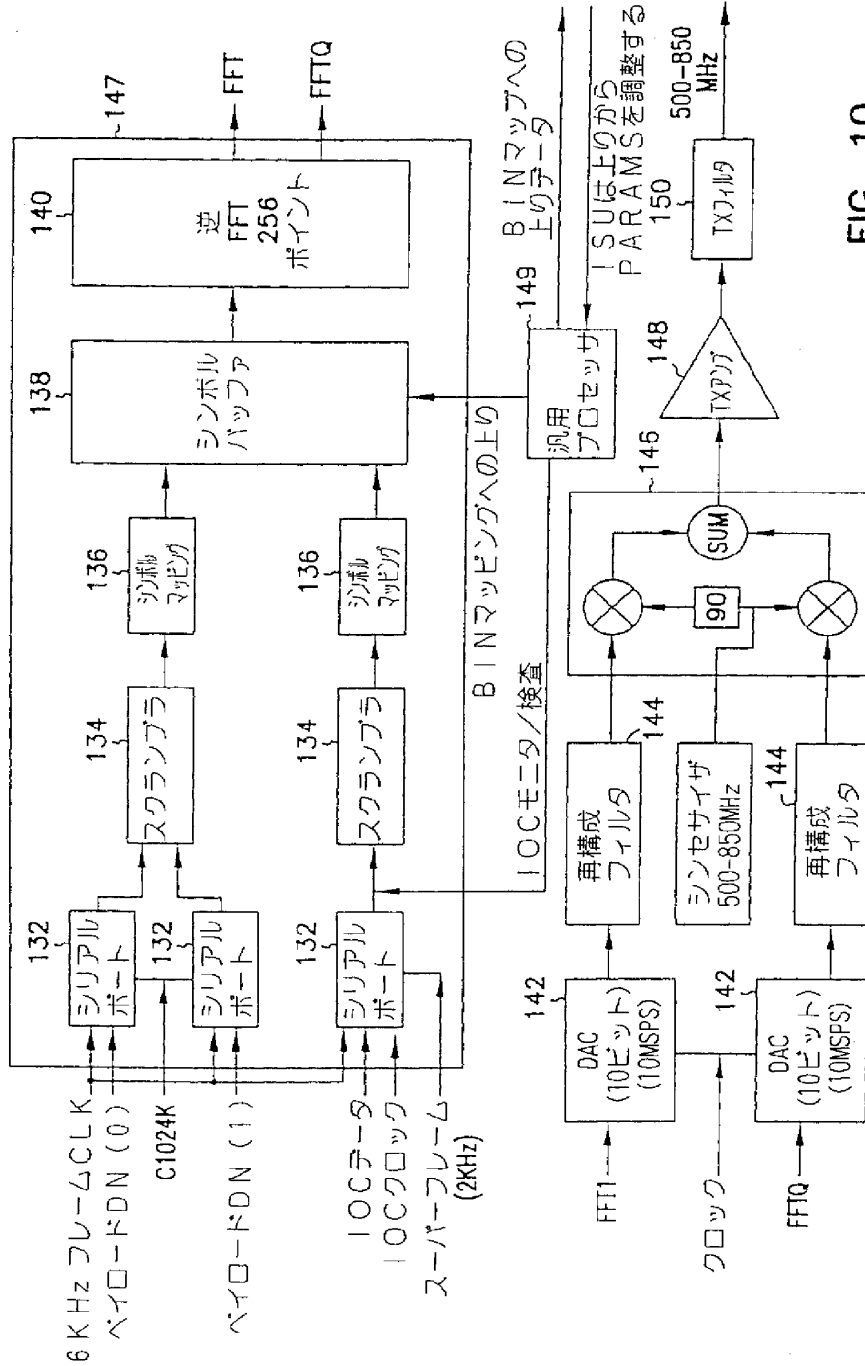

FIG. 10

【図11】

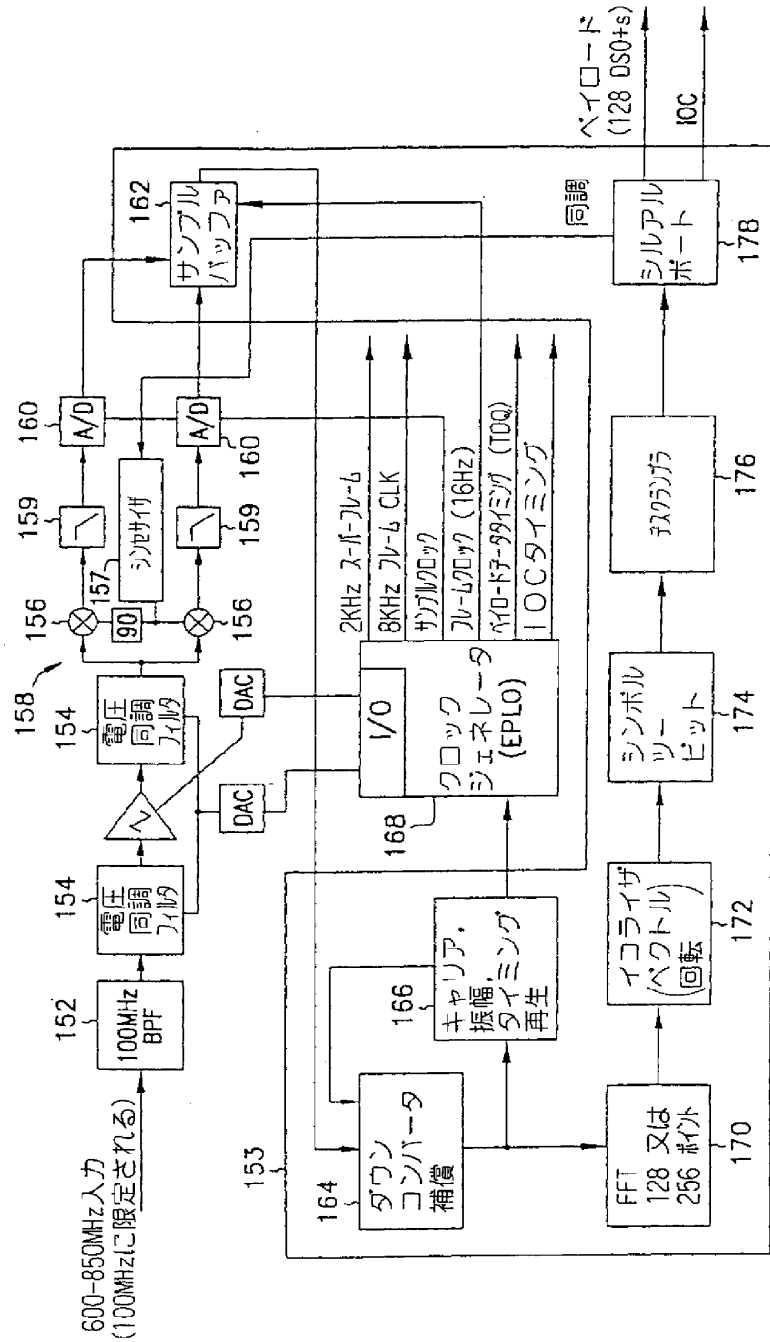

FIG. 11

【図12】

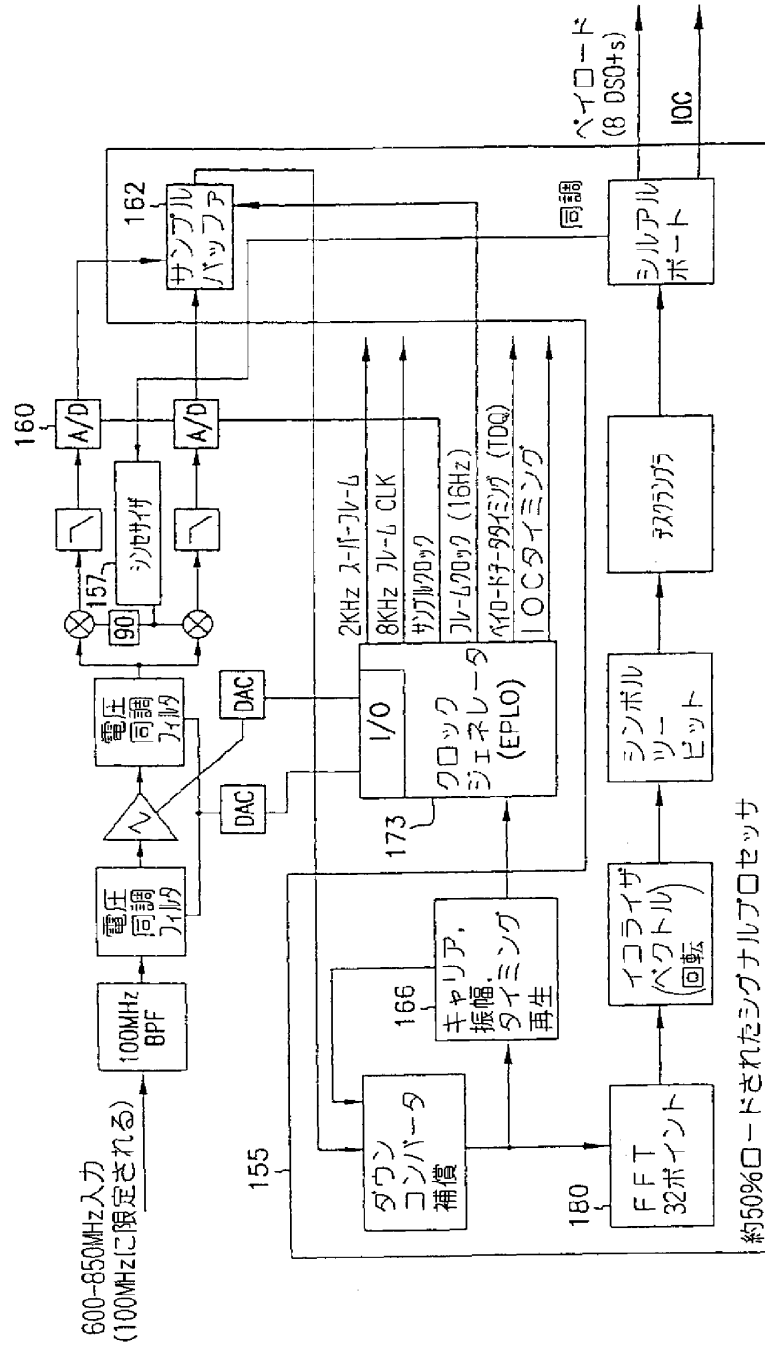

FIG. 12

【図13】

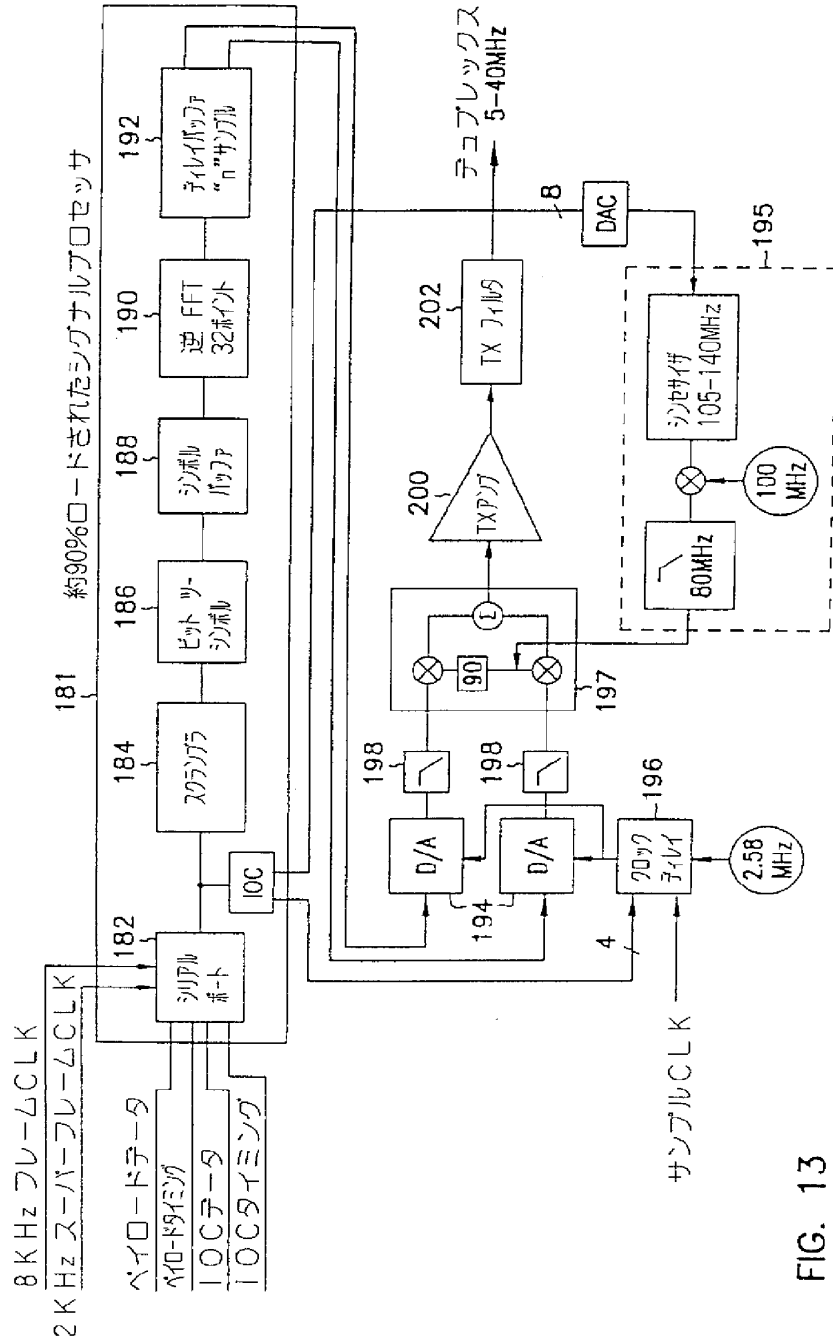

FIG. 13

【図14】

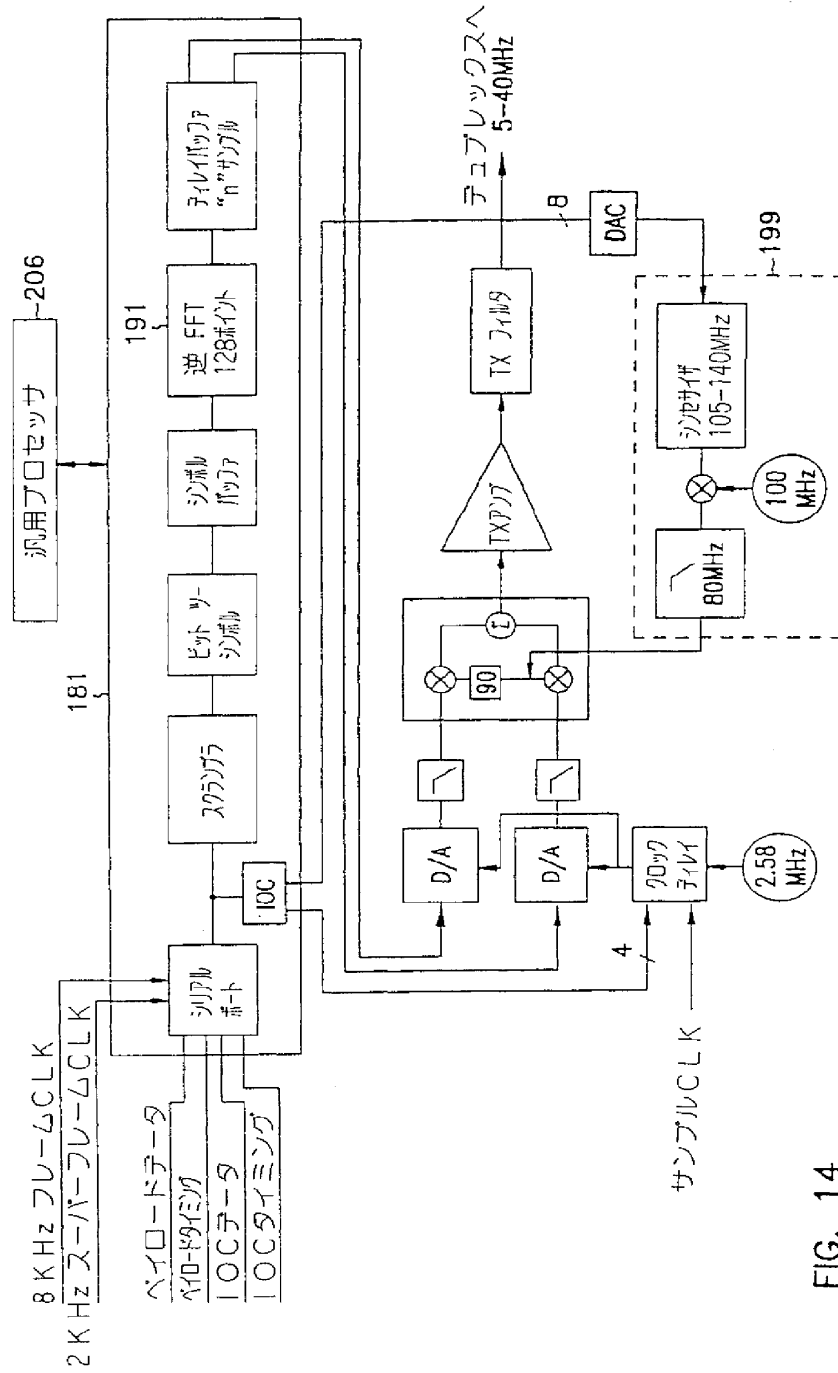

FIG. 14

【図15】

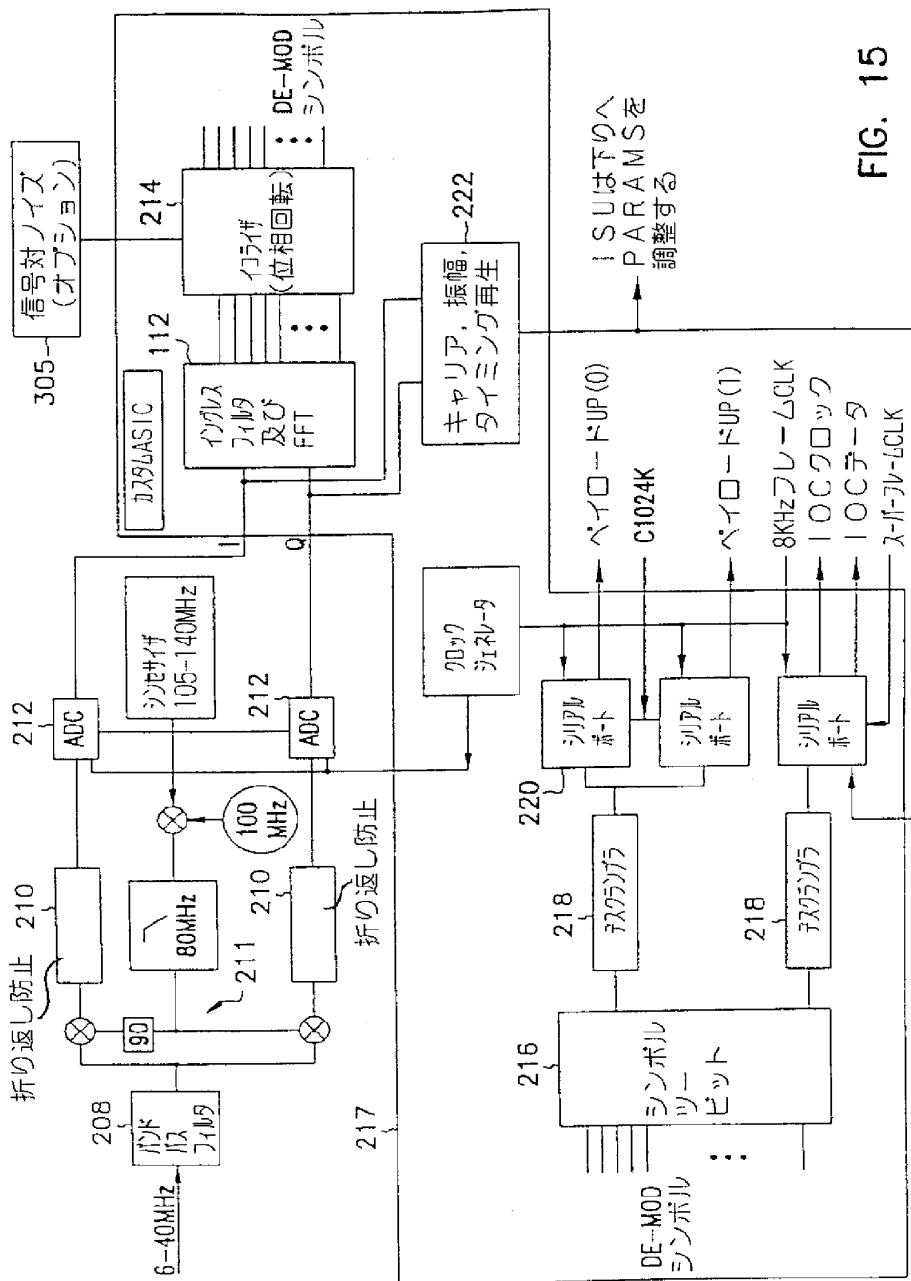

FIG. 15

【図16】

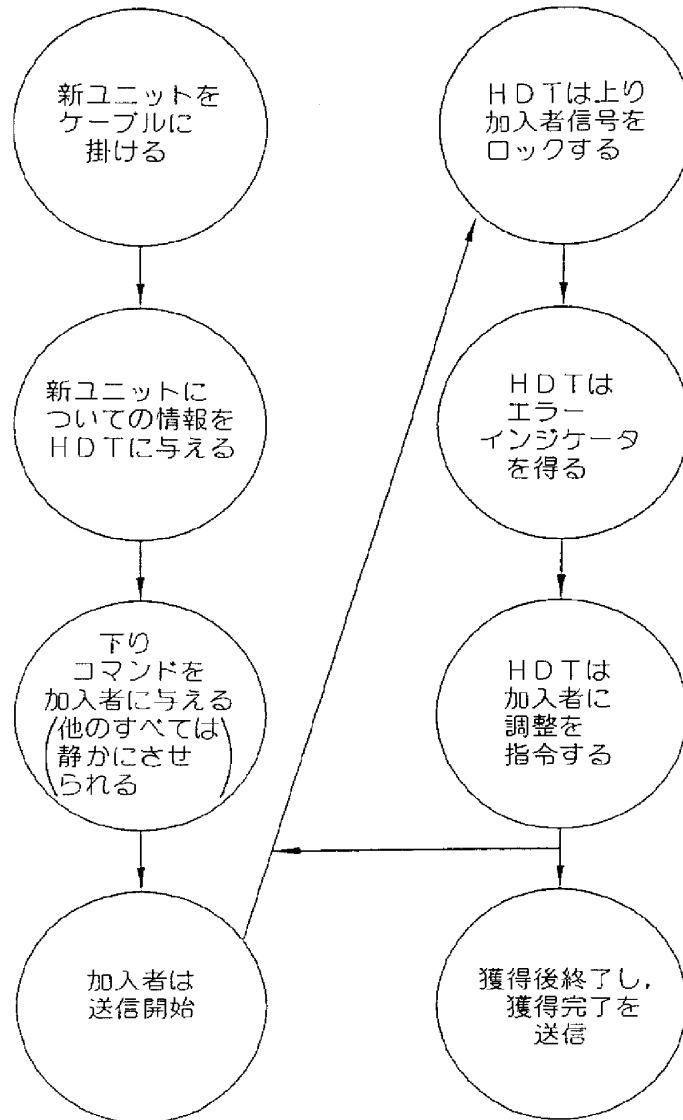

FIG. 16

【図17】

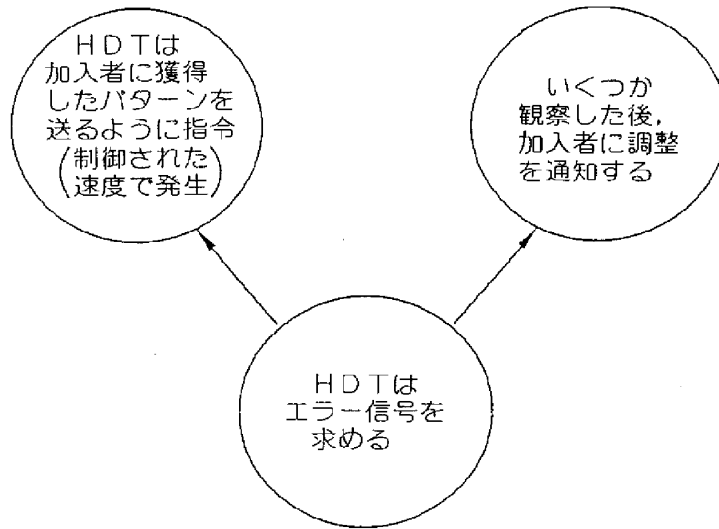

FIG. 17

【図18】

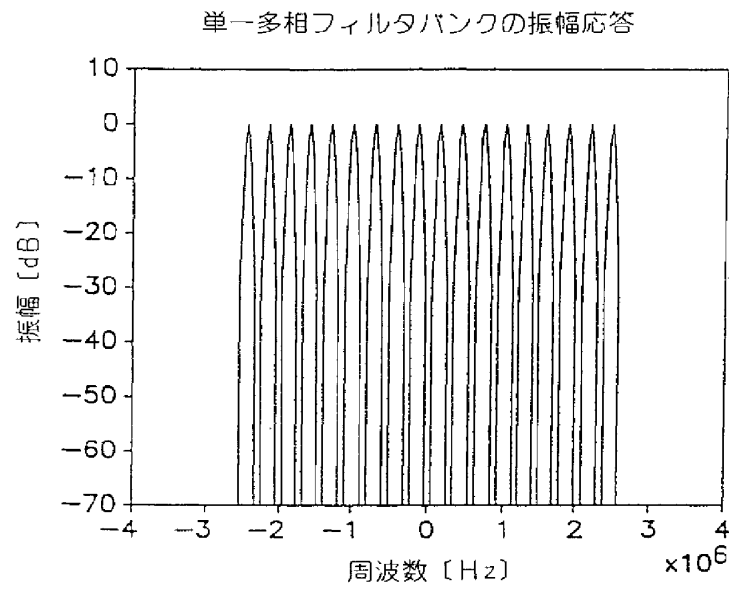

FIG. 18

【図19】

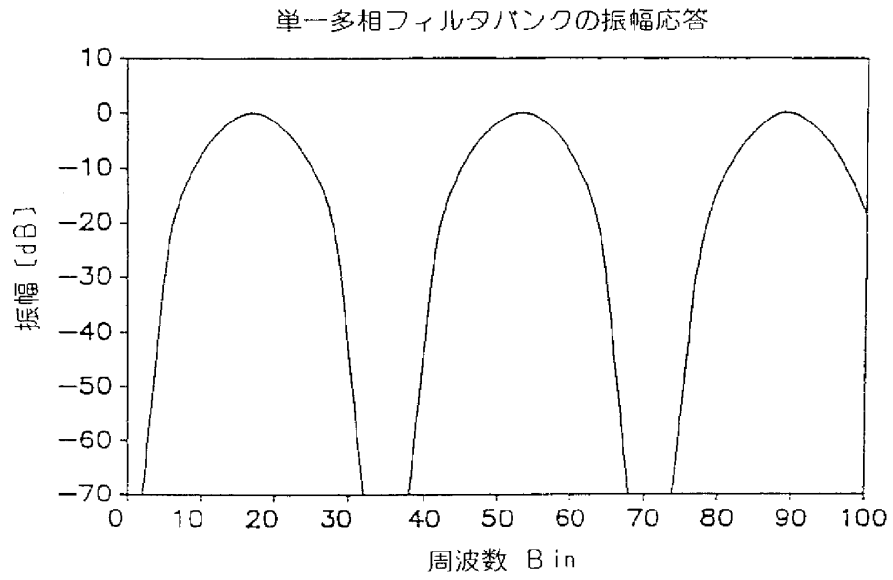

FIG. 19

【図20】

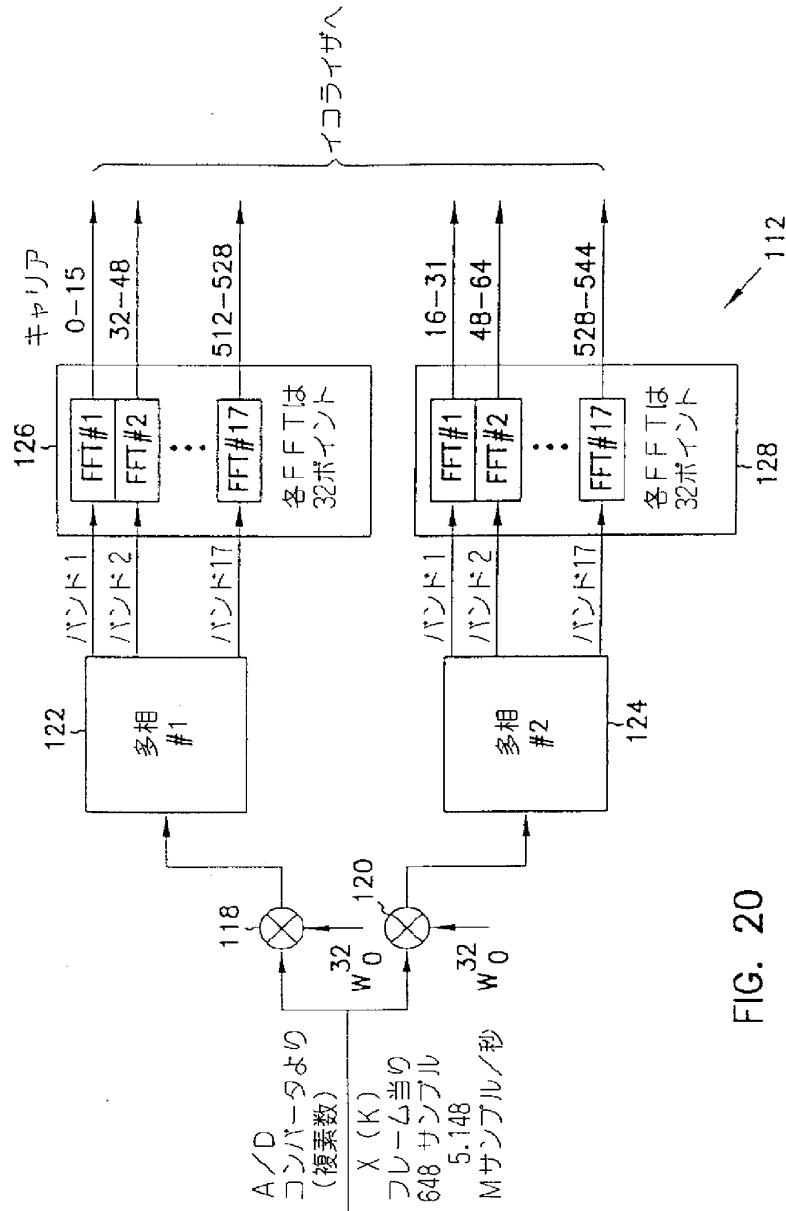

FIG. 20

【 図 2 1 】

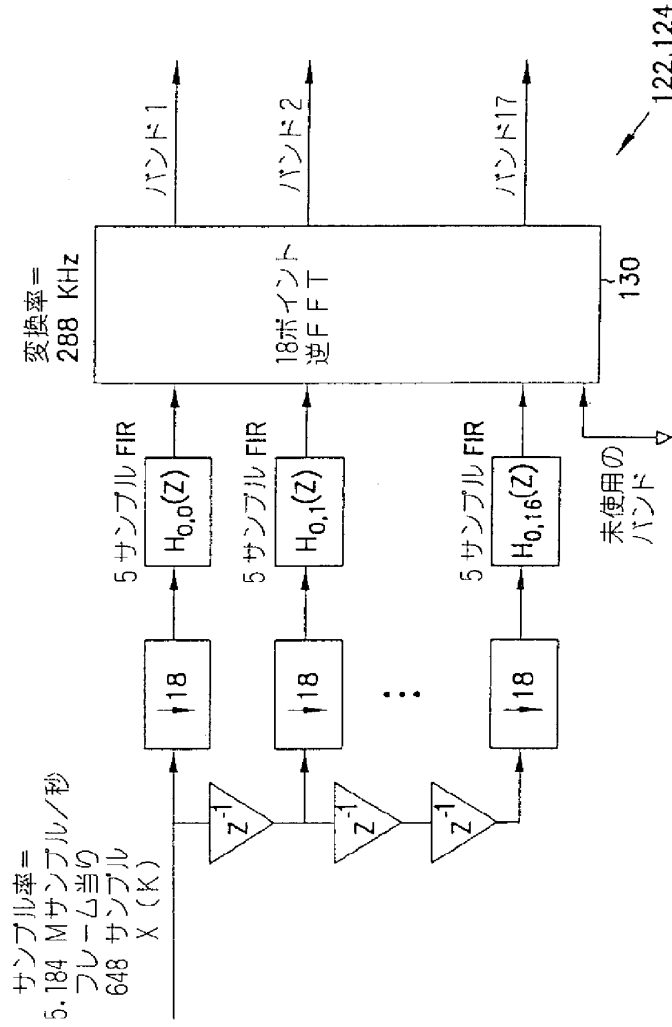

FIG. 21

【図22】

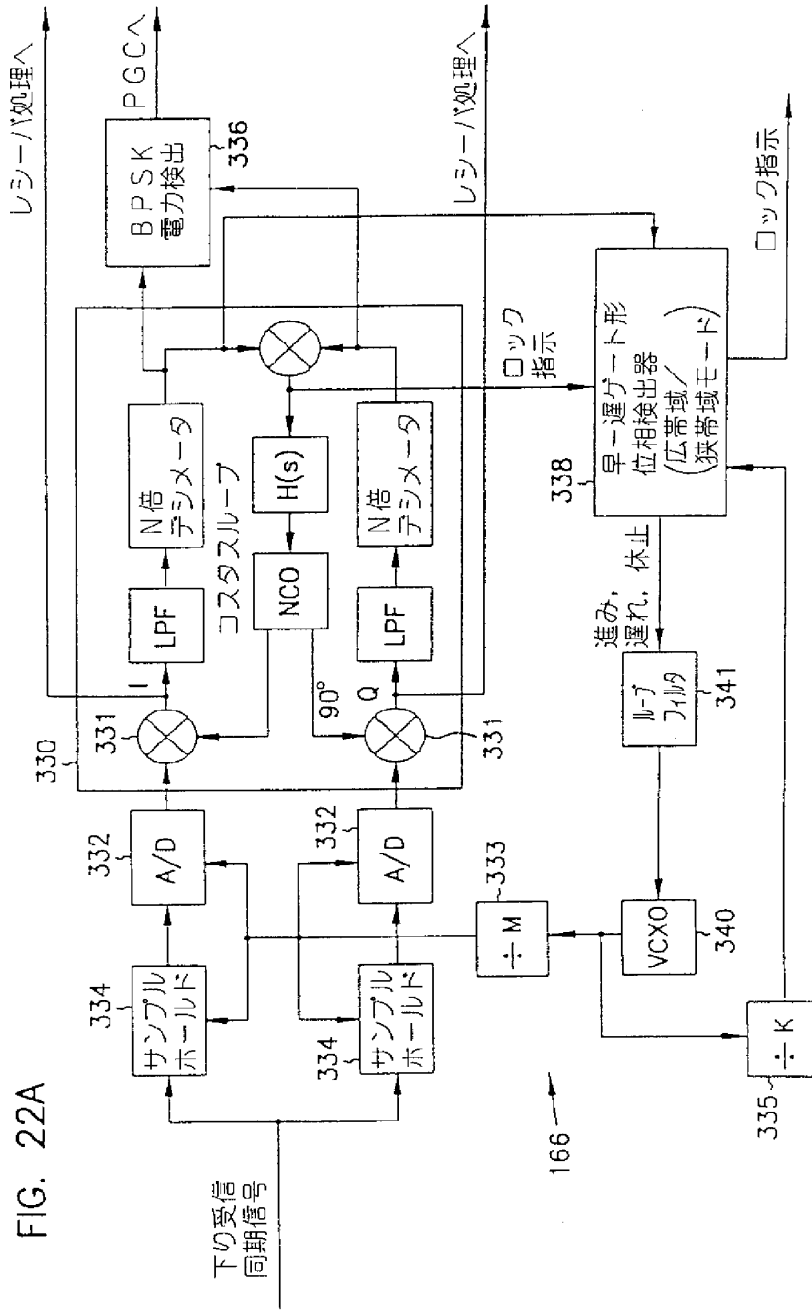

FIG. 22A

【図22】

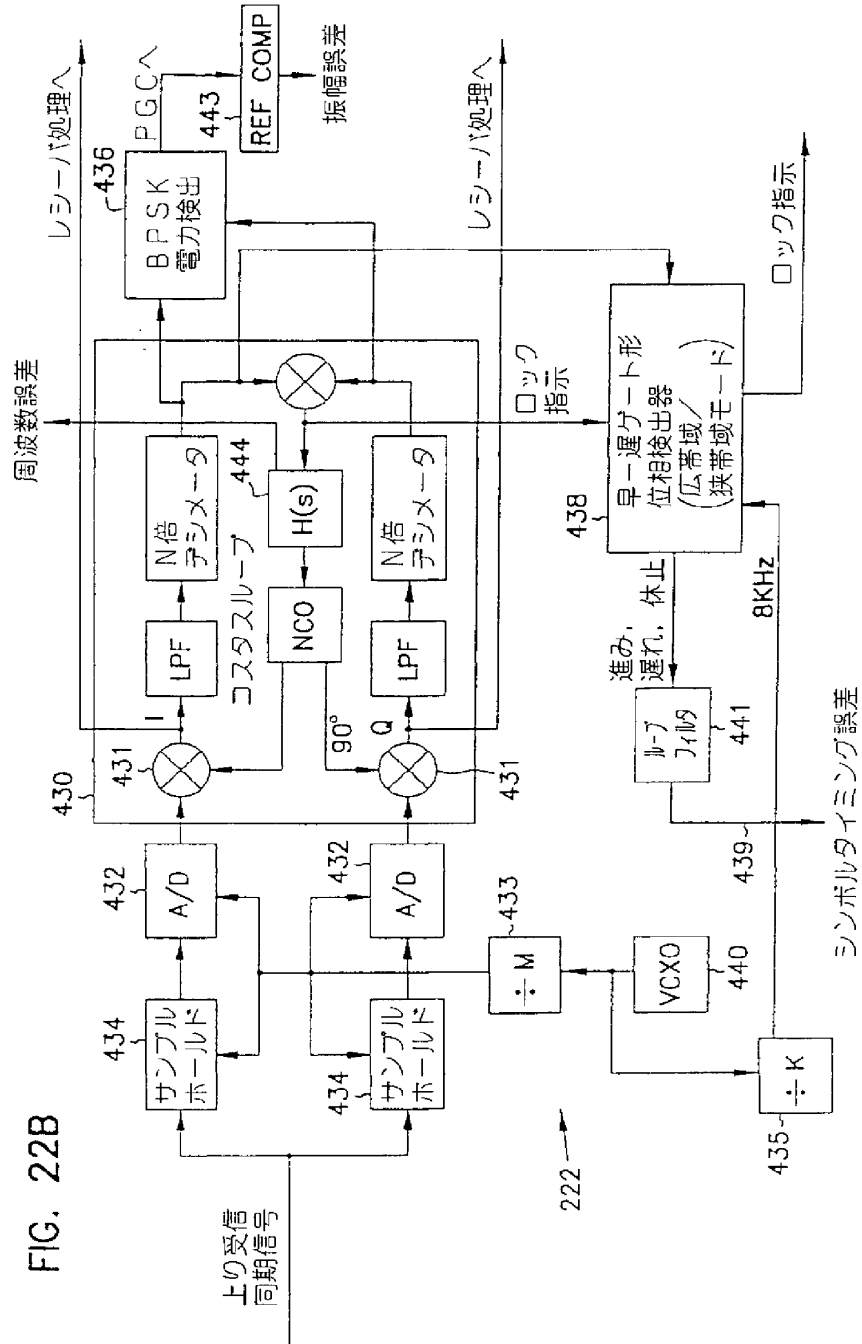

FIG. 22B

【図23】

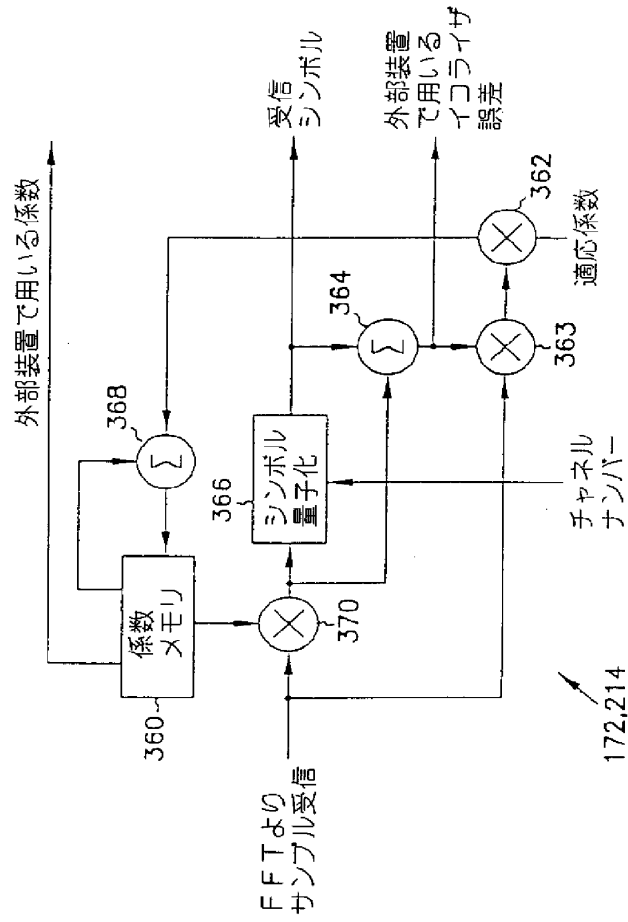

FIG. 23

【 図 2 4 】

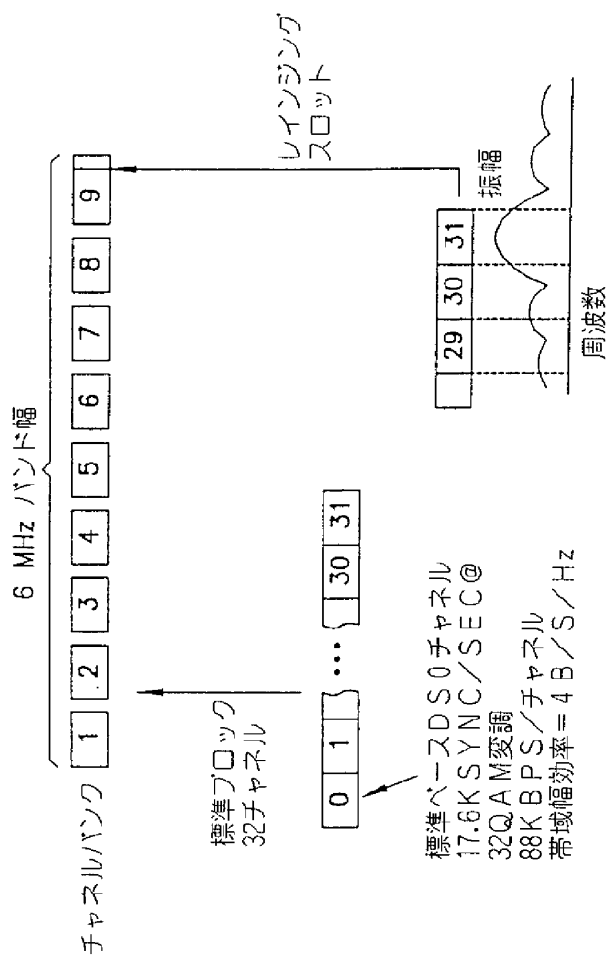

FIG. 24

【図25】

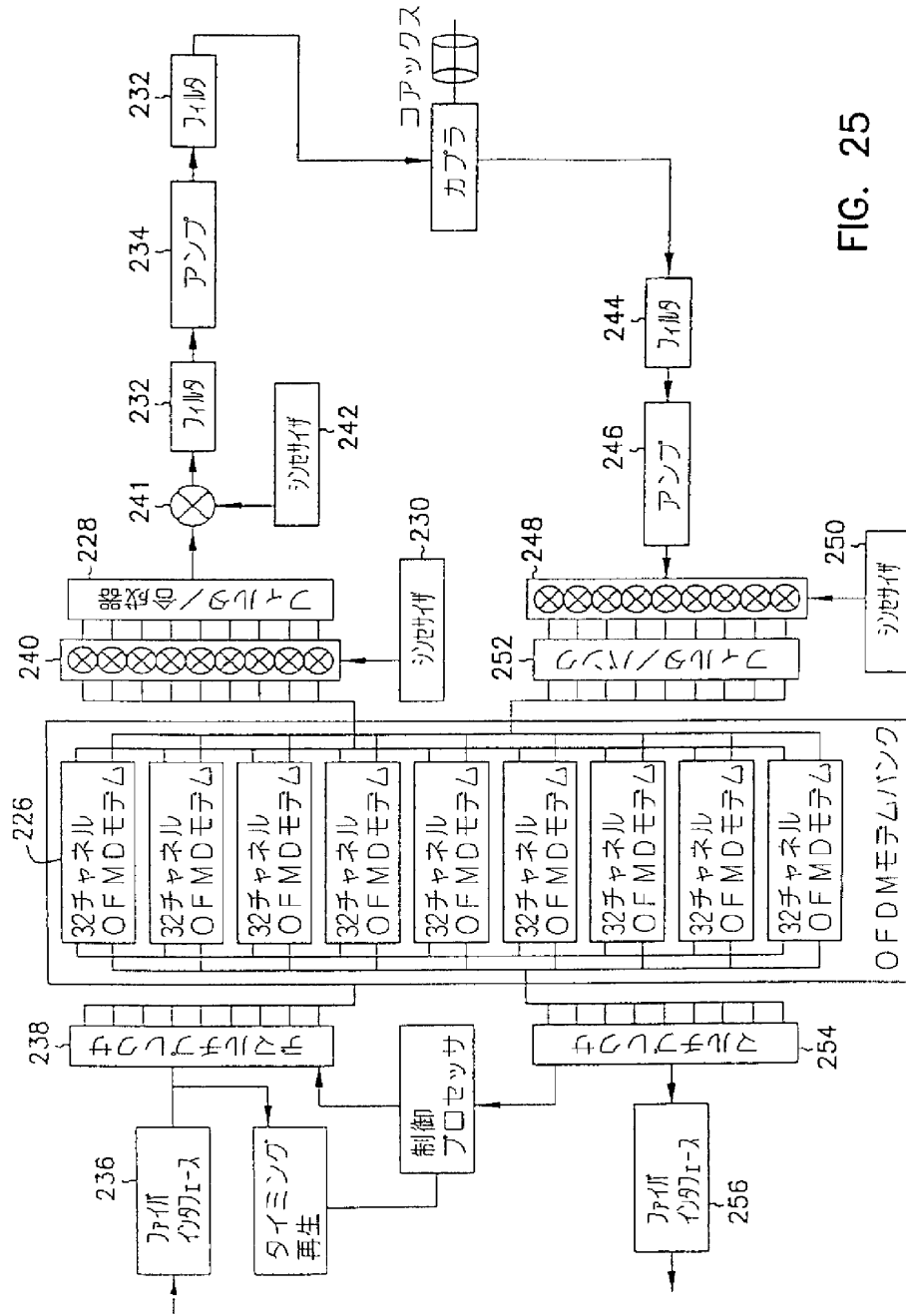

FIG. 25

【図26】

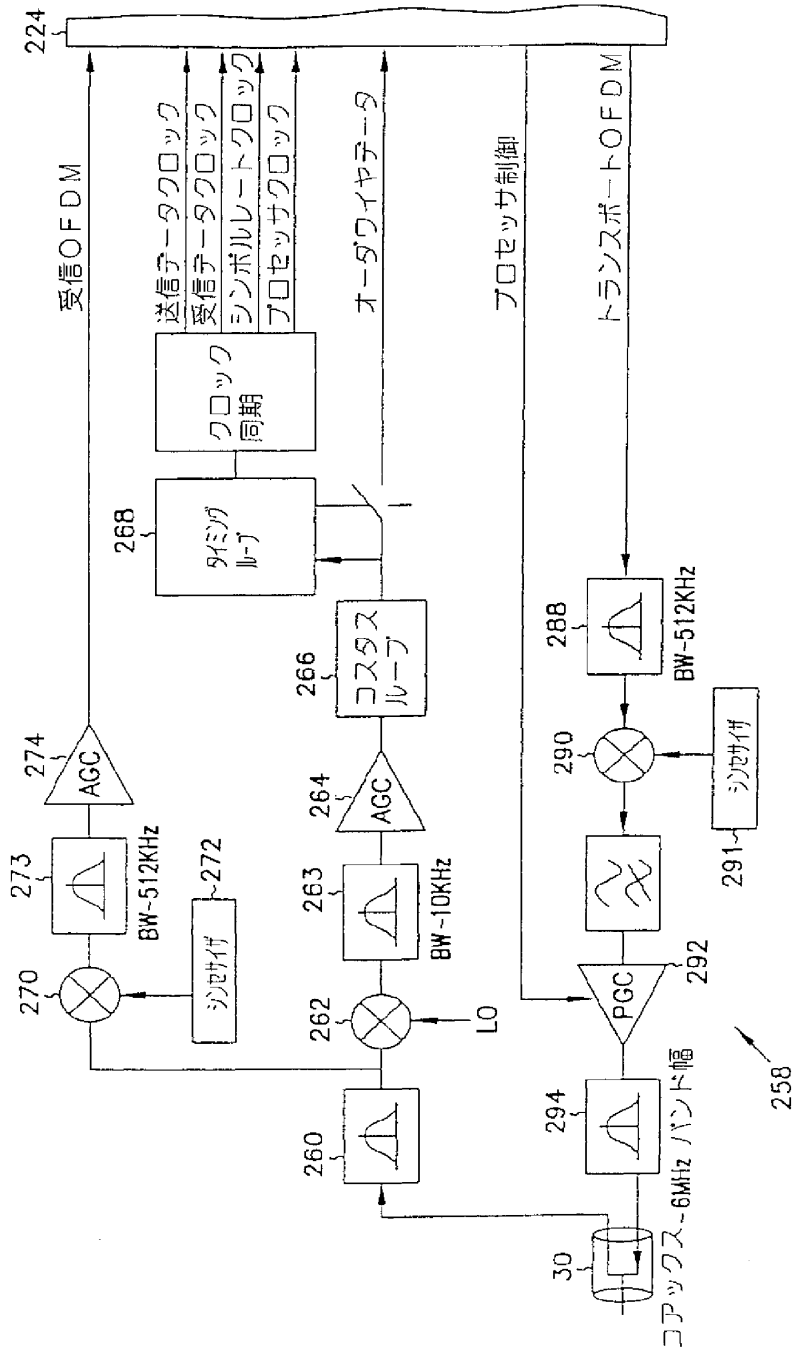

FIG. 26

加入者モデム

258

【図27】

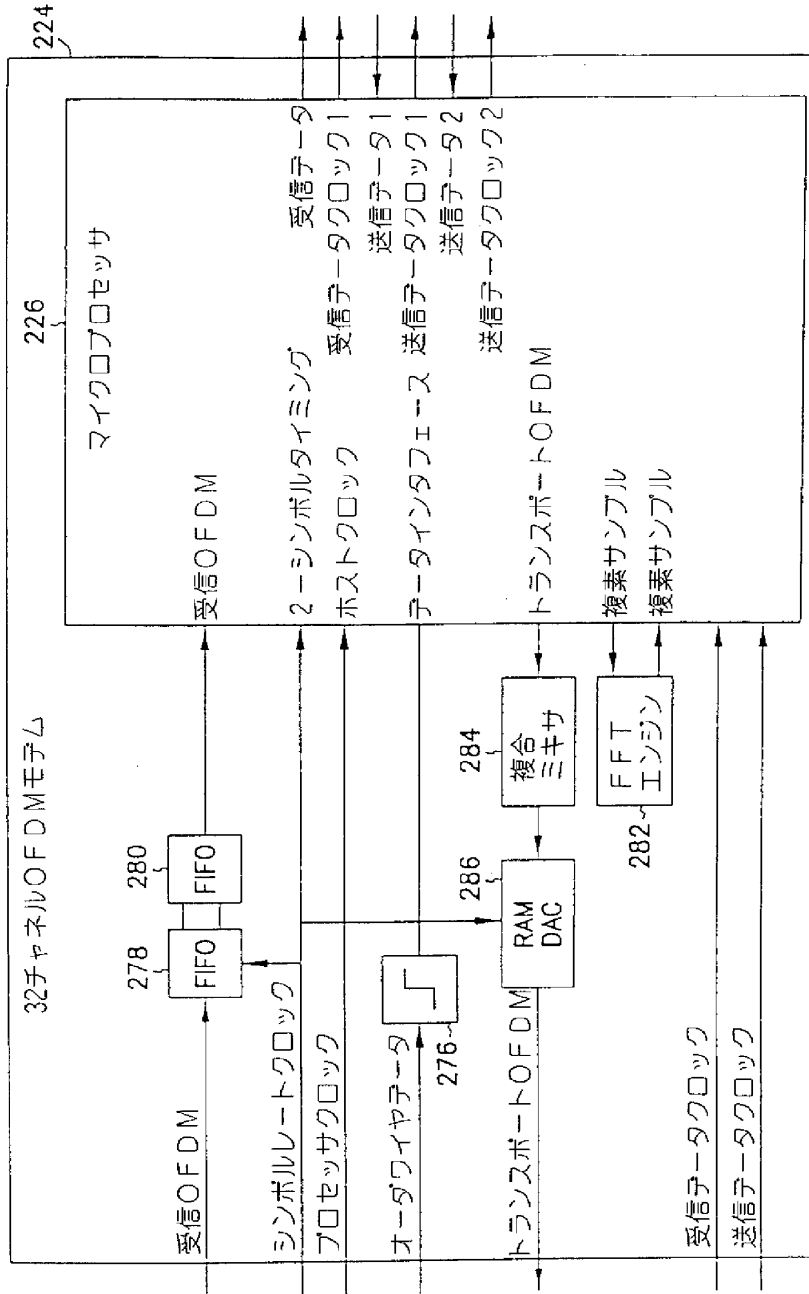

FIG. 27

【図28】

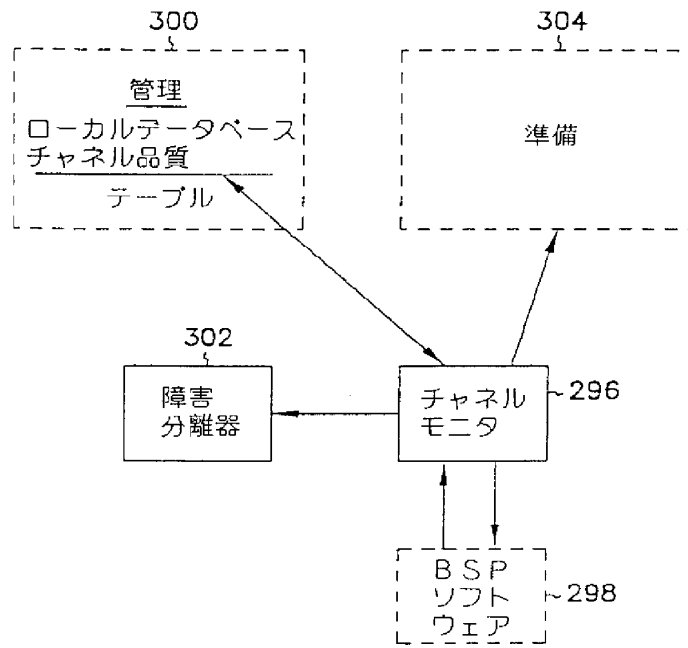

FIG. 28

【図29A】

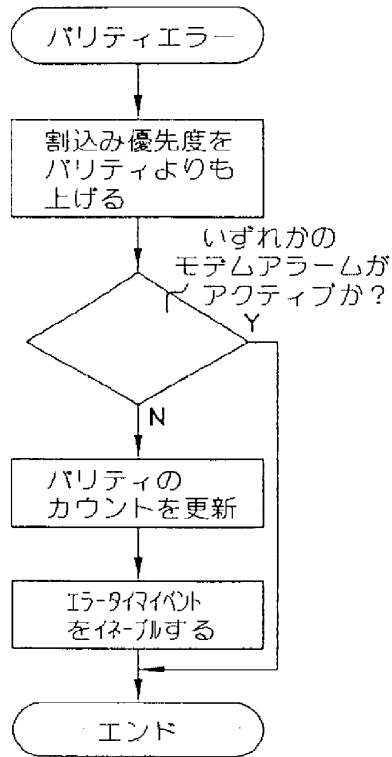

FIG. 29A

【図29B】

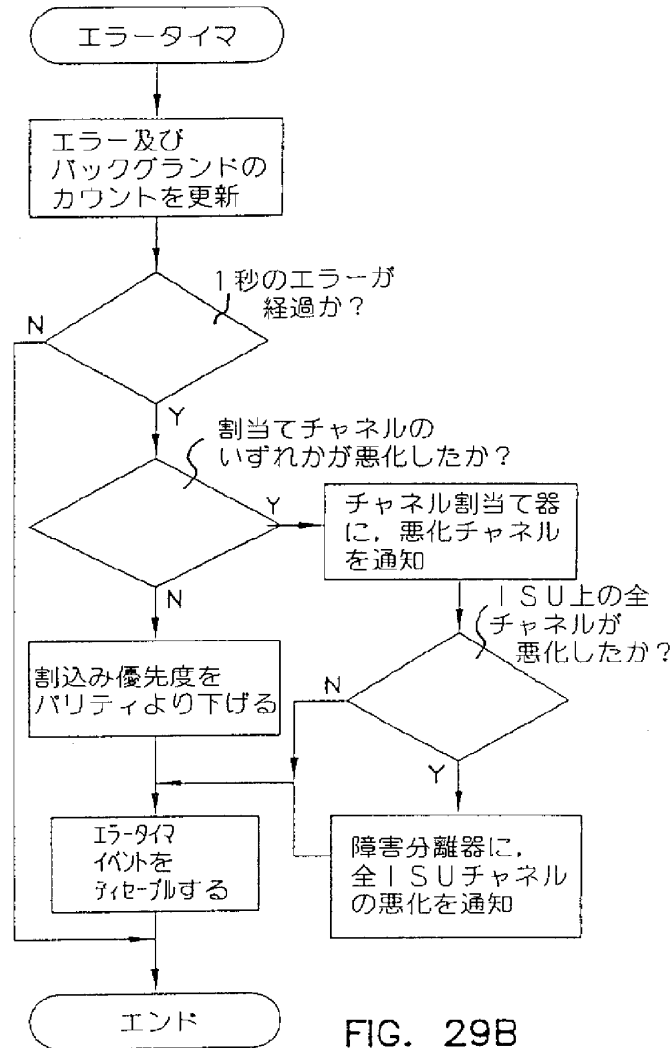

FIG. 29B

【図29C】

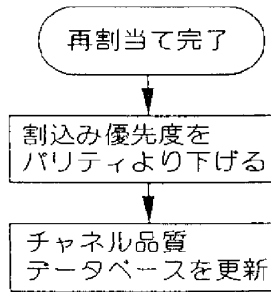
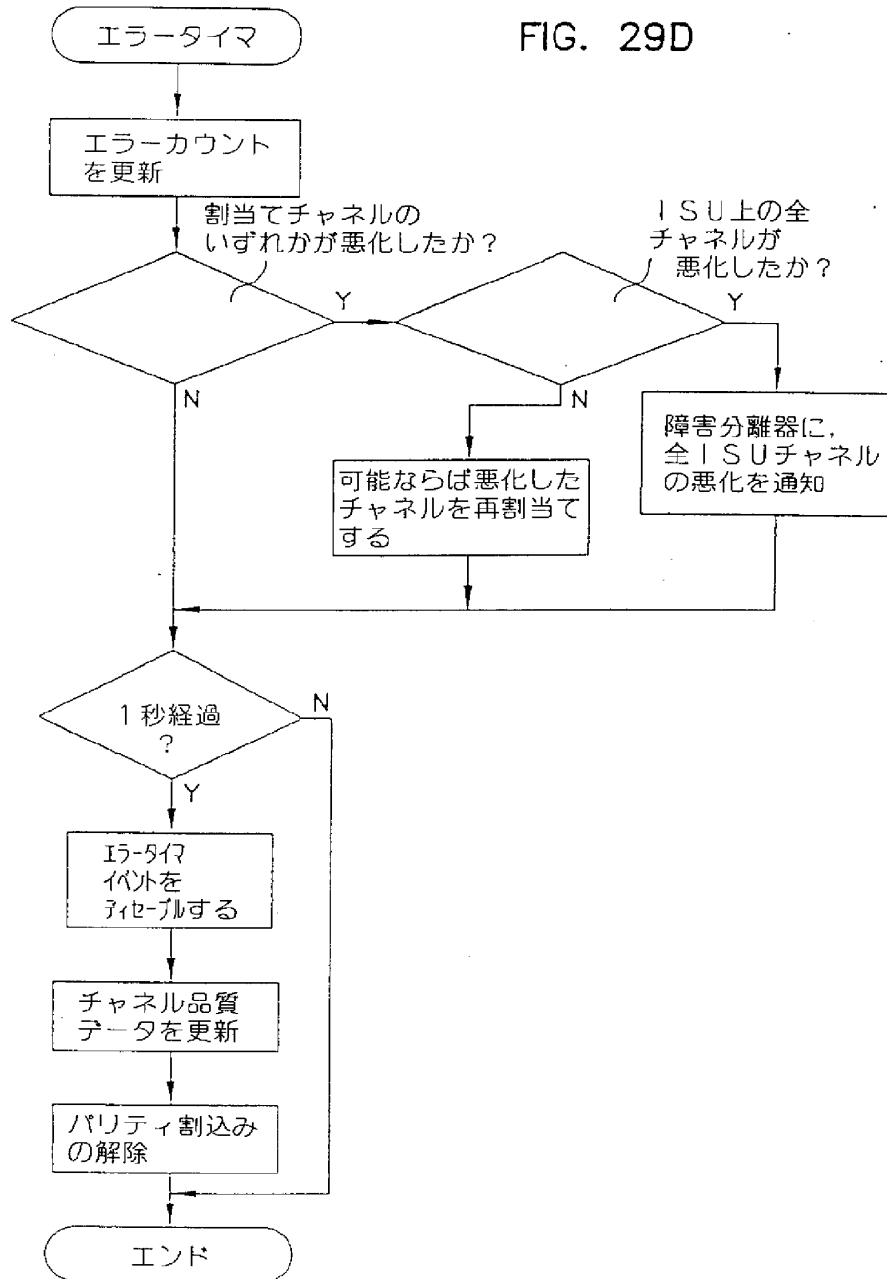

FIG. 29C

【図29】

FIG. 29D



【図30】

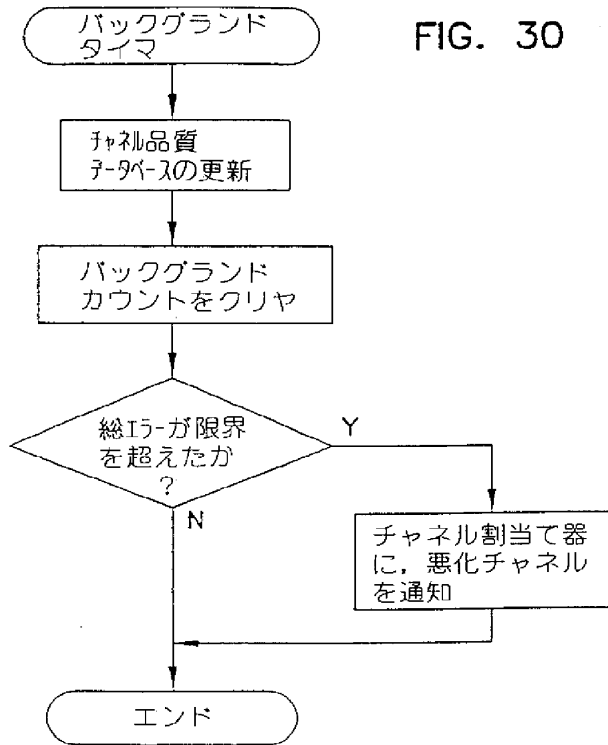

【図31】

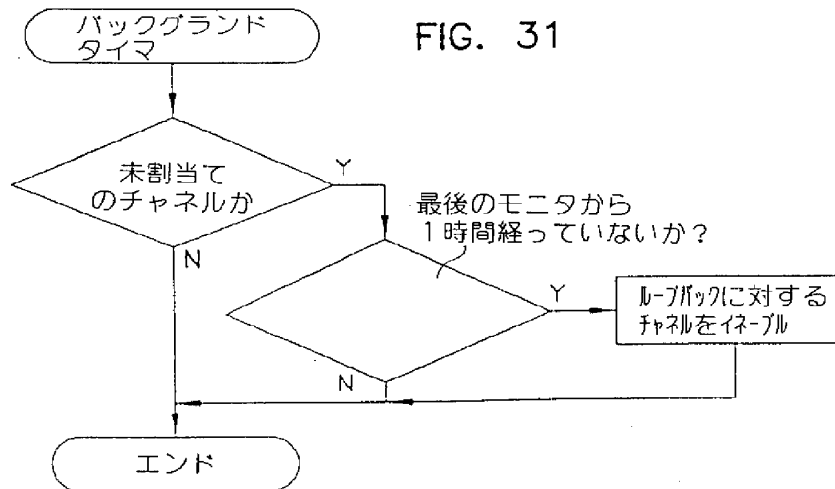

【手続補正書】【提出日】1997年12月9日【補正内容】

請求の範囲

1. nビットワードからなる電話通信チャネルの少なくとも1つのチャネルをモニタする方法であって、各ワードをなすビットの1つがパリティビットであり

、
該電話通信チャネルをなす各nビットワードのパリティビットをサンプリングするステップと、

第1の期間に亘っての該パリティビットのサンプリングから該電話通信チャネルに対して予想されうるビットエラー率を求めるステップとを具備する方法。

2. 少なくとも1つの電話通信チャネルがこわれているかどうかを決定するために、予想されうるビットエラー率を、予め決定されたビットエラー率の値と比較するステップと、

もし該チャネルがこわれているならば、該少なくとも1つの電話通信チャネルを、こわれておらずかつ割当てられていない異なる電話通信チャネルに再割当てするステップとを更に備えた、請求項1に記載の方法。

3. 少なくとも1つの電話通信nビットチャネルがこわれているかどうかを決定するために、予想されうるビットエラー率を、予め決定されたビットエラー率の値と比較するステップと、

もし該チャネルがこわれているならば、システム全体の電力を維持している間、該電話通信チャネルの伝送パワーを増加するステップとを更に備えた、請求項1に記載の方法。

4. 該nビットチャネルがこわれているかどうかを決定するために、該期間に亘って予想されうるビットエラー率を予め定められたビットエラー率の値と比較するステップを更に備えた、請求項1に記載の方法。

5. 少なくとも1つの電話通信チャネルが、複数の電話通信チャネルの帯域内に含まれており、該帯域が少なくとも1つの制御チャネルと関連しており、更に異なるチャネルが該帯域内に配置されている、請求項2に記載の方法。

6. 少なくとも1つの電話通信チャンネルが複数の電話通信チャンネルの帯域内に含まれており、該帯域は少なくとも1つの制御チャンネルと関連しており、更に異なる電話通信チャンネルが、他の少なくとも1つの関連した制御チャンネルを有する

複数の電話通信チャンネルの第2の帯域に配置されている、請求項2に記載の方法。

7. テーブル内に予想されうるビットエラー率を記憶するステップを更に備え、該テーブルは電話通信チャンネル上の将来の通信を割当てのために使用されうる、請求項4に記載の方法。

8. もし該チャンネルがこわれていないならば、少なくとも1つのより長い期間に亘ってパリティビットをサンプリングすることから少なくとも1つの付加的な予想されうるビットエラー率を求めるステップと、

該チャンネルがこわれているかどうかを決定するために、該少なくとも1つの付加的な予想されうるビットエラー率を付加的な予め定められたビットエラー率の値と比較するステップとを更に備えた、請求項4に記載の方法。

9. 予め定められたビットエラー率の値は電話通信サービス用のものであり、付加的な予め定められたビットエラー率の値は、付加的な電話通信サービス用のものである、請求項8に記載の方法。

10. 電話通信サービスの1つはISDNである、請求項9に記載の方法。

11. もし該電話通信チャンネルがこわれているならば、システム全体の電力を維持している間、該電話通信チャンネルの伝送パワーを増加させるステップを更に備えた、請求項8に記載の方法。

12. 該少なくとも1つの付加的な予想されうるビットエラー率と付加的な予め定められたビットエラー率の値との比較にもとづいて、該電話通信チャンネルから異なる電話通信チャンネルへ該通信を再割当てするステップを更に備えた、請求項8に記載の方法。

13. もし該nビットチャンネルがこわれていないならば、複数の連続する期間に亘って予想されうるビットエラー率を累積するステップを更に備えた、請求項4に記載の方法。

14. 該 n ビットチャネルがこわれているかどうかを決定するために、該連続する期間に亘っての該累積された予想されうるビットエラー率を、少なくとも 1 つの付加的な予め定められたビットエラー率の値と比較するステップを更に備えた、請求項 13 に記載の方法。

15. もし該電話通信チャネルがこわれているならば、該電話通信チャネルからの通信を第 2 の電話通信チャネルに再割当てするステップを更に備えた、請求項 14 に記載の方法。

16. もし該電話通信チャネルがこわれているならば、システム全体の電力を維持している間、該電話通信チャネルの伝送パワーを増加するステップを更に備えた、請求項 14 に記載の方法。

17. 該予め定められたビットエラー率の値は電話通信サービスと関連しており、また該少なくとも 1 つの付加的な予め定められたビットエラー率の値は、少なくとも 1 つの付加的な電話通信サービスと関連している、請求項 16 に記載の方法。

18. 該電話通信サービスの 1 つは ISDN である、請求項 17 に記載の方法。

19. もし該電話通信チャネルがこわれているならば、該電話通信チャネルから第 2 の電話通信チャネルに通信を再割当てするステップを更に備えた、請求項 13 に記載の方法。

20. もし該電話通信チャネルがこわれているならば、システム全体の電力を維持している間、該電話通信チャネルの伝送パワーを増加するステップを更に備えた、請求項 13 に記載の方法。

21. テーブル内に該予想されうるビットエラー率を記憶するステップを更に備え、該テーブルは電話通信チャネル上の将来の通信を割当てするために使用される、請求項 8 に記載の方法。

22. 少なくとも 1 つの割当てられていない電話通信チャネルをモニタする方法であって、

該少なくとも 1 つの割当てられていない電話通信チャネルを周期的にモニタするステップと、

該少なくとも1つの割当てられていない電話通信チャンネルに対するエラーデータを累積するステップと、

該少なくとも1つの割当てられていない電話通信チャンネルを、該エラーデータにもとづいて、割当てられるのを許容するステップとからなる方法。

23. こわされた電話通信チャンネルから、少なくとも1つの割当てられていない

電話通信チャンネルに、電話通信を再割当てするステップを更に備えた、請求項22に記載の方法。

24. 少なくとも1つの割当てられていない電話通信チャンネルを周期的にモニタ
する方法であって、

遠隔のトランスミッタから、各nビットワードをなすビットの1つがパリティ
ビットであるような信号を送信するステップと、

該電話通信チャンネルのパリティビットをサンプリングするステップと、

該サンプリングされたパリティビットから予想されうるビットエラー率を求め
るステップとを含む、請求項22記載の方法。

25. 割当てられていないチャンネルがパワーダウンされた割当てチャンネルである
方法であって、

該チャンネルがモニタされうるように、割当てられていないチャンネル上の遠隔の
位置で遠隔のトランスミッタをパワーアップするステップと、

該チャンネルがモニタされた後で該遠隔のトランスミッタをパワーダウンするス
テップとを更に含む、請求項22に記載の方法。

26. 該チャンネルがこわれているかどうかを決定するために、予想されうるビッ
トエラー率を予め定められたビットエラー率の値と比較するステップを更に備え
た、請求項22に記載の方法。

27. 少なくとも1つの割当てられていない電話通信チャンネルが、複数の割当て
られていない電話通信チャンネルの1つであり、少なくとも或る数の割当てられて
いない電話通信チャンネルがモニタされる方法であって、このようなモニタリング
にもとづいて少なくとも或る数の割当てられていないチャンネルの品質をランク付
けするステップを含む、請求項22に記載の方法。

28. 該ランク付けするステップは、高品質のチャンネルをスタンバイチャンネルとしてわきにセットすることを含む、請求項27に記載の方法。

【 國際調查報告 】

INTERNATIONAL SEARCH REPORT		International Application No. PCT/US 96/01606
A. CLASSIFICATION OF SUBJECT MATTER		
IPC 6	H04L1/24 H04L1/12	H04L1/20 H04J3/14
	H04L12/28 H04N7/173	H04M11/06 H04B10/24
According to International Patent Classification (IPC) or to both national classification and IPC		
B. FIELDS SEARCHED		
Minimum documentation searched (classification system followed by classification symbols)		
IPC 6	H04L	H04N H04M H04B H04J H04Q
Documentation searched other than minimum documentation to the extent that such documents are included in the fields searched		
Electronic data base consulted during the international search (name of data base and, where practical, search terms used)		
C. DOCUMENTS CONSIDERED TO BE RELEVANT		
Category *	Citation of document, with indication, where appropriate, of the relevant passages	Relevant to claim No.
X	EP,A,0 599 515 (AMERICAN TELEPHONE AND TELEGRAPH COMPANY) 1 June 1994	1,3,5,6, 11, 15-18, 22,24,25
Y	see abstract	4,9,14, 19,23,26
A	see page 2, line 53 - page 3, line 21	2,7,8, 10,12, 13,20, 21,27-34
	see page 4, line 9 - line 24; figures 1,2 ---	
Y	WO,A,93 00751 (MICROCOM SYSTEMS INC.) 7 January 1993 see abstract see page 6, line 29 - line 34 see page 7, line 8 - line 14 see claims ---	4,9,14, 19,23,26

	-/--	
<input checked="" type="checkbox"/>	Further documents are listed in the continuation of box C.	<input checked="" type="checkbox"/> Patent family members are listed in annex.
* Special categories of cited documents:		
'A' document defining the general state of the art which is not considered to be of particular relevance 'E' earlier document but published on or after the international filing date 'L' document which may throw doubts on priority claim(s) or which is cited to establish the publication date of another citation or other special reason (as specified) 'O' document referring to an oral disclosure, use, exhibition or other means 'P' document published prior to the international filing date but later than the priority date claimed		'T' later document published after the international filing date or priority date and not in conflict with the application but cited to understand the principle or theory underlying the invention 'X' document of particular relevance; the claimed invention cannot be considered novel or cannot be considered to involve an inventive step when the document is taken alone 'Y' document of particular relevance; the claimed invention cannot be considered to involve an inventive step when the document is combined with one or more other such documents, such combination being obvious to a person skilled in the art '&' document member of the same patent family
Date of the actual completion of the international search		Date of mailing of the international search report
5 August 1996		12.08.95
Name and mailing address of the ISA European Patent Office, P. B. 5818 Patentlaan 2 NL - 2280 HV Rijswijk Tel. (+31-70) 340-2040, Tx. 31 651 epo nl, Fax (+31-70) 340-3016		Authorized officer Gries, T

INTERNATIONAL SEARCH REPORT

 Intern
 nal Application No
 PCT/US 96/01606

C.(Continuation) DOCUMENTS CONSIDERED TO BE RELEVANT		
Category *	Citation of document, with indication, where appropriate, of the relevant passages	Relevant to claim No.
X	EP,A,0 399 611 (PHILIPS ELECTRONIC AND ASSOCIATED / PHILIPS' GLOEILAMPENFABRIEKEN) 28 November 1990	28-30, 32-34
A	see abstract; claims see column 3, line 50 - column 4, line 58 see column 2, line 37 - line 42 ---	31
A	US,A,4 291 403 (WADDILL ET AL.) 22 September 1981 see column 2, line 18 - line 57 see column 1, line 31 - line 35 see column 1, line 9 - line 13 see abstract ---	1-34
A	PATENT ABSTRACTS OF JAPAN vol. 10, no. 293 (E-443) [2349] , 4 October 1986 & JP,A,61 111036 (NEC CORP.), 29 May 1986, see abstract ---	1,5,16, 24,28
A	PATENT ABSTRACTS OF JAPAN vol. 8, no. 167 (E-258) [1604] , 2 August 1984 & JP,A,59 063833 (TOSHIBA K.K.), 11 April 1984, see abstract ---	1,5,16, 24,28
A	ELEKTRONIK, 7 MAY 1982, WEST GERMANY, vol. 31, no. 9, ISSN 0013-5658, pages 51-58, XP002010137 HUCKETT P ET AL: "Fehleranalyse bei digitalen Übertragungssystemen." see page 55, left-hand column, paragraph 2 - right-hand column, paragraph 2 see page 52, left-hand column, paragraph 2 - right-hand column, paragraph 1; figure 2 ---	1,5,16, 24,28
A	PROCEEDINGS OF THE IEEE, AUG. 1982, USA, vol. 70, no. 8, ISSN 0018-9219, pages 805-828, XP002010138 NEWCOMBE E A ET AL: "Error rate monitoring for digital communications" see page 810, left-hand column, paragraph 2 - right-hand column, paragraph 2 ---	1-34
A	IEEE 1981 INTERNATIONAL CONFERENCE ON COMMUNICATIONS, DENVER, CO, USA, 14-18 JUNE 1981, 1981, NEW YORK, NY, USA, IEEE, USA, pages 35.4.1-3 vol.2, XP002010139 GOLASA R G ET AL: "Performance monitoring for digital radio" see page 35.4.2, left-hand column, paragraph 2 - paragraph 3 ---	1,5,16, 24,28
	-/--	

Form PCT/ISA/216 (continuation of second sheet) (July 1992)

INTERNATIONAL SEARCH REPORT

International Application No.
PCT/US 96/01606

C.(Continuation) DOCUMENTS CONSIDERED TO BE RELEVANT		
Category	Citation of document, with indication, where appropriate, of the relevant passages	Relevant to claim No.
A	GB,A,2 266 433 (TELEFONAKTIEBOLAGET L M ERICSSON) 27 October 1993 see page 11, line 27 - page 17, line 33 see abstract ---	33,34
P,X	WO,A,95 13579 (ADVANCED TECHCOM INC.) 18 May 1995 see abstract see page 1, line 29 - page 3, line 5; claims; figures -----	1-3,5,6, 15-18, 22,24, 25, 28-30, 32-34

Form PCT/ISA/210 (continuation of second sheet) (July 1992)

INTERNATIONAL SEARCH REPORT

Information on patent family members

International Application No
PCT/US 96/01606

Patent document cited in search report	Publication date	Patent family member(s)	Publication date
EP-A-599515	01-06-94	US-A- 5513185	30-04-96
		CA-A- 2105544	24-05-94
		JP-A- 6216972	05-08-94
WO-A-9300751	07-01-93	US-A- 5241565	31-08-93
		AU-B- 2295292	25-01-93
EP-A-399611	28-11-90	GB-A- 2232326	05-12-90
		DE-D- 69025353	28-03-96
		JP-A- 3050926	05-03-91
		US-A- 5200956	06-04-93
US-A-4291403	22-09-81	NONE	
GB-A-2266433	27-10-93	US-A- 5448750	05-09-95
		CA-A- 2094549	23-10-93
		GB-A- 2292655	28-02-96
		NZ-A- 247401	21-12-95
		SE-A- 9301243	23-10-93
WO-A-9513579	18-05-95	AU-B- 8018894	29-05-95
		US-A- 5515380	07-05-96

Form PCT/ISA/210 (patent family annex) (July 1992)

フロントページの続き

(81)指定国 EP(AT, BE, CH, DE, DK, ES, FR, GB, GR, IE, IT, LU, MC, NL, PT, SE), OA(BF, BJ, CF, CG, CI, CM, GA, GN, ML, MR, NE, SN, TD, TG), AP(KE, LS, MW, SD, SZ, UG), UA(AZ, BY, KG, KZ, RU, TJ, TM), AL, AM, AT, AU, AZ, BB, BG, BR, BY, CA, CH, CN, CZ, DE, DK, EE, ES, FI, GB, GE, HU, IS, JP, KE, KG, KP, KR, KZ, LK, LR, LS, LT, LU, LV, MD, MG, MK, MN, MW, MX, NO, NZ, PL, PT, RO, RU, SD, SE, SG, SI, SK, TJ, TM, TR, TT, UA, UG, UZ, VN

(72)発明者 ロバーツ, ハロルド エー.
 アメリカ合衆国, ミネソタ 55346, エデン
 プレイリー, ビーコン サークル
 7017

(72)発明者 ブリード, ジェフリー
 アメリカ合衆国, ミネソタ 55347, エデン
 プレイリー, カーティス レーン
 8073

(72)発明者 ブスカ, スティーブン ピー.
 アメリカ合衆国, ミネソタ 55305, ミネ
 トンカ, スタントン ドライブ 13370

【要約の続き】

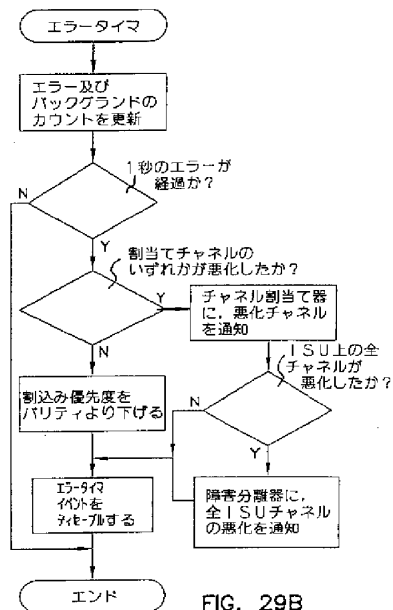

FIG. 29B

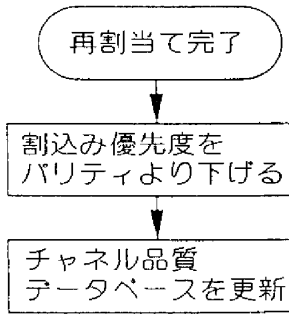

FIG. 29C

PATENT ABSTRACTS OF JAPAN

(11)Publication number : 11-261665

(43)Date of publication of application : 24.09.1999

(51)Int.Cl. H04L 29/06
H04L 29/08
H04M 11/00

(21)Application number : 11-003235

(71)Applicant : MATSUSHITA GRAPHIC
COMMUNICATION SYSTEMS INC

(22)Date of filing : 08.01.1999

(72)Inventor : STEPHEN PARM

(30)Priority

Priority number : 10 15057 Priority date : 09.01.1998 Priority country : JP

(54) COMMUNICATION DEVICE AND METHOD THEREFOR

(57)Abstract:

PROBLEM TO BE SOLVED: To exchange the negotiation data and the user data, without affecting an existing communication environment and also to check the circuit characteristic to quickly decide a communication standard that is suitable for a communication circuit and a data communication procedure.

SOLUTION: A central station system 2 and a remote system 4 properly use the user data receiving parts 60 and 64, negotiation data receiving parts 52 and 56, user data transmitting parts 62 and 58 and the negotiation data transmitting parts 54 and 50 respectively and exchange the negotiation and user data in different bands so as to exchange the transmitting and receiving capabilities. Then a random noise generating part 74 and a random noise receiving part 76 use the base tone and optional tone signals in the higher bands to check the circuit characteristics. With such a constitution, a communication standard and data communication procedures are decided.

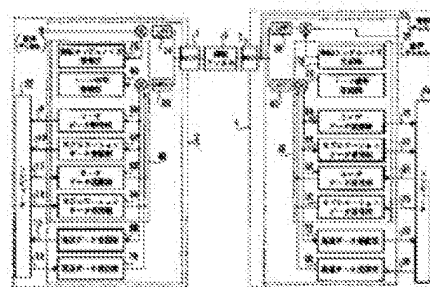

(19) 日本国特許庁 (J P)

(12) 公開特許公報 (A)

(11) 特許出願公開番号

特開平11-261665

(43) 公開日 平成11年(1999) 9月24日

(51) Int.Cl. ⁶	識別記号	F I
H 0 4 L 29/06		H 0 4 L 13/00 3 0 5 C
		H 0 4 M 11/00 3 0 3
H 0 4 M 11/00	3 0 3	H 0 4 L 13/00 3 0 7 A

審査請求 未請求 請求項の数36 O L (全 18 頁)

(21) 出願番号	特願平11-3235	(71) 出願人	000187736 松下電送システム株式会社 東京都目黒区下目黒2丁目3番8号
(22) 出願日	平成11年(1999) 1月8日	(72) 発明者	ステファン・バーム 東京都目黒区下目黒2丁目3番8号 松下電送システム株式会社内
(31) 優先権主張番号	特願平10-15057	(74) 代理人	弁理士 鷺田 公一
(32) 優先日	平10(1998) 1月9日		
(33) 優先権主張国	日本 (J P)		

(54) 【発明の名称】 通信装置及び通信方法

(57) 【要約】

【課題】 既存の通信環境に影響を及ぼすことなく、ネゴシエーションデータ、ユーザーデータの交換を行うとともに、回線特性の検査を行い、短時間で通信回線に適した通信規格、データ通信手順を決定すること。

【解決手段】 中央局システム2と遠隔システム4とは、ユーザーデータ受信部60、64、ネゴシエーションデータ受信部52、56、ユーザーデータ送信部62、58、ネゴシエーションデータ送信部54、50、を適宜使用し、異なる帯域でネゴシエーションデータとユーザーデータとを交換することにより、送受信能力の交換を行う。また、ランダムノイズ生成部74、ランダムノイズ受信部76により、更に高帯域の基本トーン信号とオプシントーン信号とを使用して、回線特性検査を行う。これらにより、通信規格、データ通信手順を決定する。

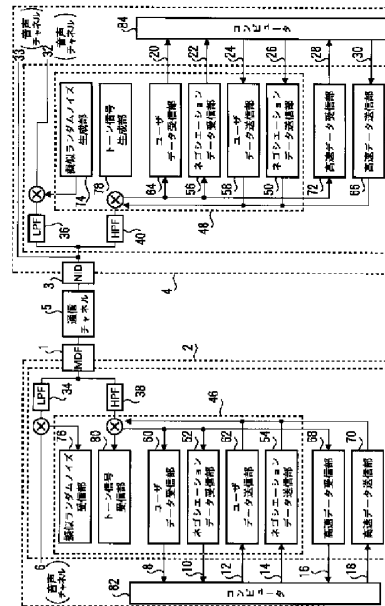

【特許請求の範囲】

【請求項1】 通信チャネルの条件を検査する工程と、検査された通信チャネル条件と各通信規格の能力に基づいて通信規格を選択する工程とを具備し、複数の通信規格から一つの通信規格を選択する、ことを特徴とする通信方法。

【請求項2】 通信チャネルの条件を検査する工程は、通信チャネルを介して第一信号を発信する工程と、通信チャネルの評価結果を受信する工程と、受信された評価結果に応じて通信規格を選択する工程と、を具備する、ことを特徴とする請求項1記載の通信方法。

【請求項3】 通信規格を選択する工程は、複数のxDSLモデム規格から一つのxDSLモデム規格を選択する工程を含む、ことを特徴とする請求項1記載の通信方法。

【請求項4】 通信チャネル条件を検査する工程と実質的に同時時間帯に、複数の通信規格の各能力を示す通信規格能力情報を発信する工程を更に具備する、ことを特徴とする請求項1記載の通信方法。

【請求項5】 通信チャネル条件を検査する工程と実質的に同時時間帯に、ユーザデータを発信する工程を更に具備する、ことを特徴とする請求項1記載の通信方法。

【請求項6】 通信チャネル条件を検査する工程は、通信チャネルにスプリッタが存在するか否かを判定する工程を更に具備する、ことを特徴とする請求項1記載の通信方法。

【請求項7】 通信チャネルを介して通信規格に関するネゴシエーション情報を少なくとも送信または受信する第一通信装置と、通信チャネルの回線特性を判定するために、通信チャネルを介して検査情報を少なくとも送信または受信する第二通信装置とを具備し、データ交換を行う、ことを特徴とする通信装置。

【請求項8】 前記ネゴシエーション情報と前記検査情報とは、実質的に同時時間帯に交換される、ことを特徴とする請求項7記載の通信装置。

【請求項9】 前記ネゴシエーション情報と前記検査情報とは、異なる時間帯に交換される、ことを特徴とする請求項7記載の通信装置。

【請求項10】 前記検査信号は、異なる周波数帯域の複数の信号を有する、ことを特徴とする請求項7記載の通信装置。

【請求項11】 前記通信装置は、所定の第一周波数帯域の通信チャネルを介して前記検査情報を交換する、ことを特徴とする請求項7記載の通信装置。

【請求項12】 前記通信装置は、所定の第二周波数帯域においてオプション検査信号を交換する、ことを特徴とする請求項11記載の通信装置。

【請求項13】 二つの場所間でネゴシエーション情報を交換する第一通信装置と、ユーザ情報を少なくとも送信又は受信する第二通信装置と、を具備することを特徴

とする通信装置。

【請求項14】 前記ネゴシエーション情報は、通信規格に関する情報である、ことを特徴とする請求項13記載の通信装置。

【請求項15】 前記ネゴシエーション情報は、通信チャネル特性に関する情報である、ことを特徴とする請求項13記載の通信装置。

【請求項16】 所定のデータ通信に関するネゴシエーション情報を交換する第一通信装置と、所定の第二通信帯域の利用可能性を示す為に用いられるフォールバック通知信号を、所定の第二データ通信帯域で交換する第二通信装置とを具備し、データ交換を行うことを特徴とする通信装置。

【請求項17】 所定の第二データ通信帯域は、音声帯域を有する、ことを特徴とする請求項16記載の通信装置。

【請求項18】 前記ネゴシエーション情報と前記フォールバック通知信号とは、実質的に同時時間帯に交換される、ことを特徴とする請求項16記載の通信装置。

【請求項19】 前記ネゴシエーション情報と前記フォールバック通知信号とは、異なる時間帯に交換される、ことを特徴とする請求項16記載の通信装置。

【請求項20】 第一通信帯域が使用できない場合に使用される音声帯域通信装置を、更に具備することを特徴とする請求項17記載の通信装置。

【請求項21】 前記フォールバック通知信号は、音声帯域におけるいかなる通信とも干渉しない、ことを特徴とする請求項17記載の通信装置。

【請求項22】 前記フォールバック通知信号は、スペクトラム拡散信号を有する、ことを特徴とする請求項21記載の通信装置。

【請求項23】 発呼側と被呼側との間でデータ交換を行う通信方法であって、

被呼側で所定の信号が検出されたか判定する工程と、被呼側で所定の信号が検出されない場合にフォールバック手順を開始する工程と、発呼側と被呼側の能力を確認するために発呼側と被呼側との間でネゴシエーション情報を交換する工程と、発呼側と被呼側とのいずれかによりチャネル情報を受信する工程と、交換されたネゴシエーション情報と受信されたチャネル情報の少なくとも一つを用い、適切な通信規格を選択し、通信回線を確立する工程と、を具備することを特徴とする通信方法。

【請求項24】 受信したチャネル情報を解析する工程と、交換されたネゴシエーション情報と受信されたチャネル情報の少なくとも一つに関連付けられた解析された情報を用いて、適切な通信規格を選択する工程と、を更に具備することを特徴とする請求項23記載の通信方法。

【請求項25】 フォールバック手順は音声手順の使用を具備することを特徴とする請求項23記載の通信方

法。

【請求項26】 発呼側と被呼側との間でユーザデータを交換する工程、を更に具備することを特徴とする請求項23記載の通信方法。

【請求項27】 通信チャネルの回線特性を判定する手段と、前記判定手段によって判定された前記通信チャネルの回線特性に基づいて、前記通信チャネルを介して高速データ通信を開始する手段と、を具備することを特徴とする通信装置。

【請求項28】 高速データ通信チャネルは、音声帯域より高い周波数帯域を用いる、ことを特徴とする請求項27記載の通信装置。

【請求項29】 通信装置の通信規格を判定する手段を更に具備し、前記高速データ通信は、前記判定された通信規格と回線特性とに従って開始される、ことを特徴とする請求項27記載の通信装置。

【請求項30】 前記判定手段が通信チャネルが高速データ通信をサポートしないと判定した場合に、音声帯域の通信チャネルを介してデータ通信を行う手段を、更に具備することを特徴とする請求項27記載の通信装置。

【請求項31】 前記通信装置は、モデムを具備することを特徴とする請求項27記載の通信装置。

【請求項32】 通信チャネルにスプリッタが存在しているか否かを判定する手段を、更に具備することを特徴とする請求項27記載の通信装置。

【請求項33】 前記スプリッタの存在を判定する手段は、通信規格の性能の最適化を可能にすることを特徴とする請求項32記載の通信装置。

【請求項34】 前記通信装置の高速データ通信能力を示す通知信号を、音声帯域の通信チャネルを介して交換する手段を、更に具備することを特徴とする請求項27記載の通信装置。

【請求項35】 データ通信を可能にする通信方法であって、通信チャネルにおけるスプリッタの存在を検出する工程と、高速通信が利用可能か否かを判定する工程と、を具備する通信方法。

【請求項36】 前記スプリッタの存在を判定する工程は、音声帯域通信を逆に妨げることのない特性を有する信号を発する工程を、更に具備することを特徴とする請求項35記載の通信方法。

【発明の詳細な説明】

【0001】

【発明の属する技術分野】本発明はデータモデムなどの通信装置及び通信方法に関し、特に通信回線を確立するために種々の通信システム構成を検出し、適切な通信システム構成を選択することができる通信装置及び通信方法に関する。

【0002】

【従来の技術】従来、モデム（アナログおよびデジタル）などのデータ通信装置は公衆電話回線網（PST

N: Public Switched Telephone Networks）を介してある場所から別の場所にデータを送信するために使用されてきた。このようなモデムはPSTNの従来の音声帯域（例えば約0-4kHzの帯域）で動作する。初期のモデムはPSTNを介して毎秒約300ビット（bps）あるいはそれ以下の速度でデータを送信していた。

【0003】その後徐々に、インターネットの普及につれて、より高速の通信方式（例えばモデム）が要求され開発された。現在、利用可能な最高速のアナログモデム（国際電気通信連合（ITU）が定義するITU-V、34モデムと称される）は、理想的な条件下で約33,600bpsの速度でデータ送信を行う。これらのモデムはPSTNの約4kHz内の帯域でもデータ交換を行う。

【0004】数メガバイト（MB）のデータファイルを転送することも珍しくはないが、V、34変調方式を用いて動作するモデムはそのようなファイルの転送に長時間を必要とする。その結果、更に高速のモデムに対する需要が高まってきた。

【0005】したがって、従来の4kHz帯域以上のスペクトラムを用いるローカルツイストワイヤペアでデータを送信するために多くの新しい通信方法が開発されている。例えば、種々のDSL（Digital Subscriber Line: デジタル加入者回線）モデムが開発されている。これらは、例えば、DSL、ADSL、VDSL、HDSL、SDSLなどで、一般にxDSLと称される。

【0006】種々のxDSL方式の幾つかは音声帯域及び音声帯域以上の帯域での、シングルツイストペアによる同時通信を可能にする。各種xDSLそれぞれは、異なる通信方式を採用するため、上り回線及び下り回線、あるいはどちらかにおける転送速度が異なり、またツイストペア通信チャネルの使用周波数帯域も異なる。

【0007】更に、xDSLのタイプによっては、ローパスフィルタ、ハイパスフィルタ、および組合フィルタなどのフィルタを必要とする。これらのフィルタはスプリッタと称されることもあり、装置間で異なる場合もある。これらのフィルタは、音声帯域通信を伝搬する周波数帯域を、データ通信を伝搬する音声帯以上の周波数帯域から分離する。

【0008】xDSLデータ通信方式を取り巻く回線環境は、例えば、従来の音声帯域内（すなわち0-4kHz帯域）で通信を行う従来のアナログモデムと共存する能力や交換局の違い、回線の品質等、極めて多いうえ、顕著に異なり、複雑である。したがって、最適かつ干渉のない通信回線を確立するためには、通信機器能力の他に通信チャネルの能力を判定できることが不可欠である。

【0009】V、34モデム等で実現されているように

従来のスタートアップシーケンス（例えばITU-Tによって確立されたV.8およびV.8bisプロトコルなど）は、使用される変調方式、プロトコル等の異なる機器能力を同定あるいはネゴシエートする為に、各モデムから送信されるビットシーケンスを利用する。これらのスタートアップシーケンスは、従来の音声帯域通信方法にのみ適用される。これら従来のスタートアップシーケンスは、通信チャネルの構成や回線状態を検査（又は認識）しない。

【0010】しかしながら、xDSLモデムに関しては、回線条件に関する情報、例えば、周波数特性、ノイズ特性、スプリッタの有無などは、通信回線がうまく確立されるとしても、回線の確立に先立ち2つのモデムがネゴシエーションするとき有用である。

【0011】音声帯域での回線プロービング技術は、技術的にはよく知られており、音声帯域回線条件情報を判定するために用いることができる。このような技術は、一定の変調方法、例えばV.34を最適化する為に、有効に使用されてきている。多重変調方法を有する装置で、V.8あるいはV.8bisはネゴシエート及び特定の変調を選択する為に使用されてきており、その変調開始シーケンスが起動した後に、回線プロービング技術が、通信チャネルの状態を表示する信号を受信するために使用される。この時点で、与えられた通信チャネルが選択された変調方法を有効にサポートできないと判定されると、従来では、時間のかかる試行錯誤的なフォールバック技術が使用され、動作する変調方法を試験し検出するようにしていた。

【0012】

【発明が解決しようとする課題】したがって、よりよい通信回線を確立するために必要なものは、最適通信方法の選択を試みる前に回線条件を監視（検査）する方法である。このように、一定の変調方式に対してデータ速度を上げる技術は既に確立されているものの、従来では、通信方法の選択を補助するためにチャネル情報を利用する方法は提供されていない。

【0013】残念ながら、現在の技術水準では、通信能力のネゴシエーションは、より効率のよいチャネル構成を認識することなく起動する。スペクトラム、スプリッタ等を明確に認識することは、適切な通信メカニズム（変調方式）を選択するためには不可欠である。

【0014】本発明は、かかる点に鑑みてなされたものであり、現存する回線条件に適した特定の(xDSL)通信規格を決定するために、通信チャネルおよび関連機器の種々の構成、能力および制限を検出する。換言すれば、本発明は、既存の通信環境に影響を及ぼすことなく、ネゴシエーション、ユーザーデータの交換を行うとともに、回線特性の検査を行い、通信回線に適した通信規格、データ通信手順を短時間で決定することができる、通信装置、通信方法、を提供することを目的とする。

る。

【0015】

【課題を解決するための手段】上記目的を達成するために、本発明は、幾つかの個々の技術を一つのシステムとして使用することとした。具体的には、中央局システムと遠隔システムとの2つのシステムの間で、異なる帯域でネゴシエーションデータとユーザーデータとを交換することにより送受信能力の交換を行うとともに、回線特性検査を行うようにした。これらにより、使用すべき通信規格、データ通信手順が決定される。

【0016】

【発明の実施の形態】本発明の一例の形態によれば、複数の通信方法（例えば、DSL規格）を実施するモデム間のネゴシエートを行い、通信に使われる一つの共通通信規格を選択する方法及び装置を提供する。通信制御部は、ネゴシエーションチャネルにおいてハンドシェイク手順（プロトコル）を実行し、通信交換において使用するxDSLの種別の識別情報を含む、高速データ通信に関する情報を取得する。通信規格は、事実上の、独占的な、あるいは、企業あるいは政府によって発行された、あらゆるタイプの規格に適用される。

【0017】他の態様において、本発明は、検査信号を用い、中央局通信システムと遠隔通信システム間の通信チャネルの特性を判定する方法を提供する。検査信号は、例えば周波数ロールオフ、ノイズ等以外の障害を検出する。これら障害は、中央局システムと遠隔システム間で識別され明らかにされる。通信チャネル品質に関する情報により、本発明は、継続する通信規格の選択に関してより正確な判定（例えば、ADSLの代わりにCDSL、あるいはVDSLの代わりにCDSLを用いる等）を行うことができる。

【0018】他の態様において、本発明は、周波数帯域を分離する為に使用される機器の有無を判定する方法及び装置を提供する。多くの場合、そのような機器は、音声帯域以上の周波数における通信を行う為に必要とされる。その際に使用する分離装置（スプリッタ）が欠如している場合は、他の通信方法を用いることも考慮される。本発明は、スプリッタの有無を検出する方法を含んでおり、そのスプリッタは、通信に影響を及ぼさず、音声帯域を同時に行われるいかなる通信（音声通信あるいはアナログデータ通信等）とも干渉しない。

【0019】他の態様において、本発明は、高速帯域通信が可能ではないと判定されると、従来の音声帯域通信方法へフォールバックする手順を提供する。通知信号（拡散処理信号等）は、第一通信制御部により受信される従来の音声帯域内で送信される。通知信号は、従来の音声帯域内のデータ通信実行能力を示す識別信号を有する。

【0020】また、通知信号は、通信チャネルが現時点では高速通信が可能でなくても、通信機器は高速通信

が可能であるかを判定する。これにより、例えば、ユーザは高速データ通信装置（モデム等）を購入し設置することが可能になり、設置した時点で、中央局システムは、自動的にユーザサイドにおける高速通信装置の設置を検出し、遠隔システム側のユーザがそのモデムを用い高速通信チャネルの確立を要求することができるようなオンライン手順を開始する。

【0021】本発明の他の態様において、音声帯域で送信される通知信号（音声帯域以上で高速データ通信が可能であること示す）は、高速データ通信が開始される時に同時に音声帯域で行われる可能性のある従来の通信（音声通信あるいはアナログデータ通信等）を干渉・中断させないように選択される。通知信号は、例えば、擬似乱数シーケンスを用いて生成されるスペクトラム拡散信号でよい。あるいは、送信エネルギーを音声帯域内で均等に拡散させる他のスペクトラム拡散技術を用いてもよい。

【0022】本発明の他の態様において、エンドユーザ間通信、例えばユーザ名、パスワード等の交換（送信）は、通信チャネル検査（回線プロービング等）が完了し高速通信能力が交換される前に、ユーザ専用チャネルを介して開始することができる。従来では、通信システムは、エンドユーザ間でデータが通信されるまでに、長いトレーニング（あるいは起動）時間を必要とした。本発明では、高速通信を行うための（チャネル及び通信方法の）試験及びネゴシエーションを行うと同時に、通信パスの確立を行うことができる。

【0023】本発明の種々の態様を組み合わせることにより、通信チャネルと設置された機器の検査を効果的かつ効率よく行い、最適な通信方法を選択する方法及び装置が提供される。システム設計者、設置業者、プロバイダは、通信の最適手段を効率よく規定する為のネゴシエーションがおこなわれている間に、本発明で考慮される種々のパラメータを設定することができる。

【0024】本発明によれば、可能な高速通信の判定、サポートされている高速データ通信能力の交換と選択、通信回線特性の検査、等を同時に実行することができるため、判定したデータ通信手順のハンドシェイクプロトコルに直ちに移行することができる。

【0025】本発明は、最適ネゴシエーションの為に、通信チャネルの両サイドで実施されることが好ましい。しかしながら、通信チャネルの一つのサイドだけが本発明を実施してもよい。更に、一つのサイドが、本発明を部分的に実施してもよい。そのような構成は、正確に通信システムに報告され、適当とされる場合には、通信システムが従来の通信方法（アナログ等）をサポートしていれば、通信システムはそれら従来の通信方法にフォールバックできる。

【0026】更に、本発明は、実際の高速通信装置で実施する必要がない。本発明は、通信チャネルを終端し、

または分岐するインテリジェントスイッチにおいて実施できる。これにより、通信システムは、個々の装置（あるいはモデム）において実施される、種々の通信規格を収容することができる。これら通信規格は、中央局システムと遠隔システムとの能力及び要求の明確なネゴシエーションにより、必要に応じて正確に割り当てられる。

【0027】本発明によれば、複数の通信規格の中から一つの通信規格を選択する方法は、通信チャネルの状態を検査する手順と、検査された通信チャネル条件と複数の通信規格の各々の能力に基づいて通信規格を選択する手順と、を有する。通信チャネル条件の検査においては、信号の通信チャネル上で第1信号を発信し、通信チャネルの影響を評価する信号を受信し、その受信信号に対応して通信規格を選択する。通信規格の選択においては、複数のxDSLモデム規格の中から一つのxDSLモデム規格を選択する。

【0028】本発明によれば、通信規格能力情報またはユーザデータは、通信チャネル状態の検査時に、実質的に同時に発信される。

【0029】更に、本発明によれば、通信チャネルにスプリッタが設置されているかを判定することができる。

【0030】本発明の他の態様に係る通信装置は、通信規格に関するネゴシエーション情報を通信チャネル上で送信または受信する第一通信装置と、通信チャネルの回線特性を判定する検査情報（異なる周波数帯における複数の信号等）を通信チャネル上で送信または受信する第二通信装置とを具備する。

【0031】本発明によれば、ネゴシエーション情報と検査情報とは、実質的に同時帯で交換される。あるいは、ネゴシエーション情報と検査情報は異なる時間帯で交換されるようにしてもよい。

【0032】また、本発明によれば、通信装置は、所定の周波数帯における通信チャネル上で検査信号を交換し、更に、第二周波数帯において、オプション検査信号を交換することもできる。

【0033】本発明の他の態様に係る通信装置は、二つのサイド間でネゴシエーション情報を交換する第一通信装置と、ユーザデータを少なくとも送信または受信する第二通信装置とを具備する。ネゴシエーション情報は、ADSL、CDSL、HDSL、等の通信規格通信チャネル特性に関するものである。

【0034】本発明によれば、データ交換の為に開示された通信装置は、所定のデータ通信に関するネゴシエーション情報を交換する第一通信装置と、所定のデータ通信帯域上でフォールバック通知信号を交換する第二通信装置とを具備する。このフォールバック通知信号は、所定の第二通信帯域が利用可能であることを示す為に用いられる。

【0035】本発明によれば、所定の第二データ通信帯域が音声帯域を具備する。この音声帯域通信装置は、第

一通信帯域が使用できない時に使用される。

【0036】本発明によれば、ネゴシエーション情報とフォールバック通知信号とが、実質的に同時時間帯でも、あるいは異なる時間帯でも交換できる。

【0037】本発明によれば、フォールバック通知信号（スペクトラム拡散信号等）が、音声帯域における他の通信と干渉しない。

【0038】本発明の他の態様に係る通信方法は、発呼側装置と応答側装置の間のデータ交換を行うものである。この方法により、所定の信号が応答側装置で検出されたか判定される。フォールバック手順（音声帯域での手順等）は、所定の信号が応答側装置で検出されない場合に、開始される。一方、所定の信号が検出されると、ネゴシエーション情報が発呼側装置と応答側装置間で交換され、発呼側装置と応答側装置間の能力が確定する。チャネル情報が、発呼側装置と応答側装置のどちらか一方で受信されると、交換されたネゴシエーション情報と受信されたチャネル情報の少なくとも一つを用いて適切な通信規格が選択され、通信回線が確立される。

【0039】本発明によれば、この方法は、更に、受信されたチャネル情報を解析し、解析された情報と、交換されたネゴシエーション情報と受信されたチャネル情報の少なくとも一つとを関連付けして用い、適切な情報規格を選択する。

【0040】本発明によれば、ユーザデータは、初期化手順が行われている間に、発呼側装置と応答側装置との間で交換される。

【0041】本発明の他の態様によれば、開示されたデータ通信装置（ばモデム等）は、通信チャネルの回線特性を判定する手段と、判定手段によって判定された通信チャネルの回線手段に基づき、通信チャネル上で高速データ通信を開始する手段とを具備する。通知信号は、通信装置の高速データ通信能力を示し、音声帯域の通信チャネル上で交換される。

【0042】本発明によれば、高速データ通信チャネルは音声帯域より高い周波数帯域を用いる。

【0043】本発明によれば、通信装置の通信規格を判定する手段を具備することができる。これにより、高速データ通信は、判定された通信規格と判定された回線特性に従って開始される。

【0044】本発明によれば、判定手段が、通信チャネルが高速データ通信をサポートしないと判定した場合、音声帯域の通信チャネル上でデータ通信を行う手段を提供することができる。

【0045】更に、本発明の他の態様に係る通信装置は、通信規格の能力を最大限引き出すために、通信チャネルにおけるスプリッタの存在を判定する手段、を具備することである。

【0046】本発明の他の態様に係る方法は、通信チャネルにおけるスプリッタの存在を検出することによりデ

ータ通信を可能にし、高速通信が利用可能かどうかを判定する。スプリッタの存在は、音声帯域通信を干渉しないような信号を用いて検出される。

【0047】以下、図1～図12を参照しつつ、本発明を、更に具体的に説明する。

【0048】図1はモデム装置を用いるデータ通信システム実施の形態1の概略ブロック図を示す。本発明は発明の趣旨と範囲から逸脱しないかぎり他の通信装置にも適用できるものと理解される。さらに、本発明はツイストペアワイヤを使用した電話通信システムを取り上げて記述されているが、本発明は発明の趣旨と範囲から逸脱しないかぎりケーブル通信システム（ケーブルモデム等）、光学通信システム、ワイヤレスシステム、赤外線通信システム等、他の通信環境にも適用できるものと理解される。

【0049】実施の形態1に係るデータ通信システムは、中央局システム2と遠隔システム4から構成され、両システムは通信チャネル5を介してインタフェースがとられる。

【0050】中央局システム2は、中央局システム2と通信チャネル5間のインタフェースとして機能するメイン分配フレーム（MDF）1を有する。MDF1は、一端に外部からの電話回線（例えば通信チャネル5）を接続し、他端に内部回線（例えば内部中央局システム回線）を接続する。

【0051】遠隔システム4には、遠隔システム4と通信チャネル5とのインタフェース機能を持つネットワークインタフェースデバイス（NID）3が搭載されている。NID3は、顧客の機器と通信ネットワーク（例えば通信チャネル5）のインタフェースとして機能する。

【0052】図2は、実施の形態1における図1のデータ通信システムを具体的に示したブロック図である。本実施の形態では、代表的なシステム、つまり、中央局システム2と遠隔システム4の両方に本発明を適用し、遠隔システム4にはスプリッタは設置されていない例を示す。

【0053】図2に示すように、中央局システム2は、低域フィルタ34、高域フィルタ38と、テストネゴシエーションブロック46と、高速データ受信部68と、高速データ送信部70と、コンピュータ82とを具備する。コンピュータ82は、中央局システムにおけるネットワーク機器に対して、総括的インタフェースとして機能する。テストネゴシエーションブロック46は、後述される、回線プロービング等のすべてのネゴシエーションを行う。これらネゴシエーションは、実際の高速データ通信の前に行われる。

【0054】低域フィルタ34と高域フィルタ38は通信チャネル5を介してて転送される通信信号をフィルタリングする。テストネゴシエーションブロック46は中央局システム2、遠隔システム4及び通信チャネル5の

条件、能力等をテストし、ネゴシエーションを行う。テストネゴシエーションブロック46の手順が完了した後、高速データ受信部(モデム等)68及び70の選択を開始する。高速データ受信部は遠隔システム4から送信された高速データを受信し、一方高速データ送信部70は遠隔システム4に高速データを送信する。高速データ部68及び70は、ADSLモデム、VDSLモデム、あるいはCDSLモデム等を具備することができる。高速データ部68及び70は、初期ネゴシエーション手順において、テストネゴシエーションブロック46を共通に用いる複数の高速送信機器から構成されてもよい。

【0055】本実施の形態では、テストネゴシエーションブロック46は、擬似ランダムノイズ受信部76と、トーン信号受信部80と、ユーザデータ受信部60と、ネゴシエーションデータ受信部52と、ユーザデータ送信部62と、ネゴシエーションデータ送信部54とを備える。

【0056】擬似ランダムノイズ受信部76は、擬似ランダムノイズを受信する。トーン信号受信部80はトーン信号を受信する。ユーザデータ受信部60はユーザデータを受信し、ユーザデータ送信部62はユーザデータを送信する。ネゴシエーションデータ受信部52はネゴシエーションデータを受信し、ネゴシエーションデータ送信部54はネゴシエーションデータを送信する。中央局システム2の種々の部分の動作の詳細について以下に示す。

【0057】ユーザデータ受信部60、ネゴシエーションデータ受信部52、及び高速データ受信部68はコンピュータ82に信号を送信する。ユーザデータ送信部62、ネゴシエーションデータ送信部54、及び高速データ送信部70はコンピュータ82から発信された信号を受信する。

【0058】遠隔システム4は、低域フィルタ36と、高域フィルタ40と、テストネゴシエーションブロック48と、高速データ受信部72と、高速データ送信部66と、コンピュータ84とを具備する。

【0059】低域フィルタ36、高域フィルタ40は通信チャネル5を介して転送される通信信号をフィルタリングする。テストネゴシエーションブロック48は、中央局システム2、遠隔システム4、及び通信チャネル5の条件、能力等をテストし、ネゴシエーションを行う。高速データ受信部72は中央局システム2から送信された高速データを受信し、一方高速データ送信部66は中央局システム2に高速データを送信する。

【0060】本実施の形態では、テストネゴシエーションブロック48は、擬似ランダムノイズ生成部74と、トーン信号生成部78と、ユーザデータ受信部64と、ネゴシエーションデータ受信部56と、ユーザデータ送信部58と、ネゴシエーションデータ送信部50と、を

有している。

【0061】擬似ランダムノイズ生成部74は擬似ランダムノイズを生成する。トーン信号生成部78はトーン信号を生成する。ユーザデータ受信部64はユーザデータを受信し、一方ユーザデータ送信部58はユーザデータを送信する。ネゴシエーションデータ受信部56はネゴシエーションデータを受信し、一方ネゴシエーションデータ送信部50はネゴシエーションデータを送信する。遠隔システム4の各部の動作の詳細を以下に説明する。

【0062】ユーザデータ受信部64、ネゴシエーションデータ受信部56、及び高速データ受信部72はコンピュータ84に信号を送信する。ユーザデータ送信部58、ネゴシエーションデータ送信部50、及び高速データ送信部66はコンピュータ84から発信された信号を受信する。

【0063】中央局システム2は、複数のチャネル6、8、10、12、14、16、18を含み、これらは遠隔システム4の複数のチャネル20、22、24、26、28、30、32との通信に使用される。この点に関して、実施の形態1においては、チャネル6は、低域フィルタ34、36によってフィルタリングされた従来の音声帯域(例えば0Hz~約4kHz)の該当する遠隔システム側の音声チャネル32と直接通信するために使用される中央局側音声チャネルを備えている。また、遠隔システム側の音声チャネル33は、遠隔システム4に設けられているが、これは中央局システム2の制御下にはない。遠隔システム側の音声チャネル33は、通信チャネル5(ただし低域フィルタ36の前)に平行に接続され、したがって遠隔システム側の音声チャネル32と同等のサービスを提供する。ただし、遠隔システム側の音声チャネル33は、低域フィルタ36の前にあるので、このチャネルには高速データ信号、音声信号のいずれも含まれる。

【0064】フィルタの周波数特性が異なるように調整することにより、音声チャネル6と32の間の例えばISDN等の他の低帯域通信方法を用いた通信が行えるようになる。高域フィルタ38と40は、4kHz以上の周波数スペクトルで通信を行う際に選択される。

【0065】ビットストリーム8、10、12、14、16、18(中央局システム2の)およびビットストリーム20、22、24、26、28、30(遠隔システム4の)は、それぞれ中央局側コンピュータ82と遠隔システム側のコンピュータ84の間の通信に使用されるデジタルビットストリームである。発明の範囲と趣旨に逸脱しないかぎり、ビットストリーム8、10、12、14、16、18は、図示されたように分散型信号として、あるいは、インターフェースやケーブルにバンドルされ、あるいは信号ストリームに多重化され実行される。例えば、ビットストリーム8、10、12、14、

16、18はRS-232C、パラレル、IEEE-1394 (FireWire)、USB (Universal Serial Bus)、ワイヤレス、あるいは赤外線 (IrDA) 規格に準じたインタフェースとして実行される。同様に、ビットストリーム20、22、24、26、28、30は、図示されたように分散型信号として、あるいは上述されたようにバンドルされ実行される。

【0066】実施の形態1によれば、ユーザID、パスワード等のユーザデータは、中央局システム2のユーザデータ受信部60とユーザデータ送信部62と、遠隔システム4のユーザデータ受信部64とユーザデータ送信部58の間で通信(交換)が実行される。

【0067】ユーザデータチャンネル60及び62は、低速通信チャンネルであり、ネゴシエーションデータ受信部52とネゴシエーションデータ送信部54で送受信されるネゴシエーション手順とは別個に、交換される。

【0068】通信回線の条件(周波数特性、ノイズ特性、スプリッタの有無等)に関するネゴシエーションデータ(制御情報等)は、中央局システム2のネゴシエーションデータ受信部52とネゴシエーションデータ送信部54と遠隔システム4のネゴシエーションデータ受信部56とネゴシエーションデータ送信部50の間で交換される。本実施の形態では、これらの通信(ネゴシエーション通信及びユーザ通信)は、異なる周波数帯域を用いて実質的に同時に(並行して)行われる。ただし、通信は、本発明の範囲と趣旨に影響しないかぎり異なる時間帯において連続的に行ってもよい。

【0069】ユーザデータチャンネル通信は、ネゴシエーションチャンネルの訂正機能をもつ必要はなく、本発明の範囲及び趣旨には影響しないかぎり省略される。本発明に係るデータ通信の例を、図3~図5を参照して説明する。図3は、中央局システム2の動作を示すフロー図である。図4は、遠隔システム4の動作を示すフロー図である。図5は、本発明のデータ通信システムで使用する信号の周波数スペクトル分布を示す概略ブロック図である。

【0070】本実施の形態において、中央局システム2と遠隔システム4の間の情報交換のための種々の通信パスでは、周波数分割多重伝送方式(FDM)が利用される。ただし、本発明の趣旨と範囲から逸脱しないかぎり他の技術(CDMA、TDMA等)も使用することができる。

【0071】図5に示すように、通信パス(周波数帯域)f1は、上りネゴシエーションチャンネルを構成する。通信パスf2(図5)は、下りネゴシエーションチャンネルを構成する。高速データ通信に関する制御情報は、上り、下りネゴシエーションチャンネルf1、f2を通じて交換される。遠隔システム4のネゴシエーションデータ送信部50は、周波数帯域f1を用いて送信し、

中央局システム2のネゴシエーションデータ受信部52は、周波数帯域f1を用いて受信する。中央局システム2のネゴシエーションデータ送信部54は、チャンネルf2の下り回線で送信を行い、遠隔システム4のネゴシエーションデータ受信部56は、周波数帯域f2を用いてデータ受信する。

【0072】通信パスf3(図5)は、ユーザIDおよびパスワード等のデータを遠隔システム4に送信するための上りユーザチャンネルを構成する。通信チャンネルf4(図5)は、ユーザIDおよびパスワード等のデータを遠隔システム4から受信するための下りユーザチャンネルを有する。遠隔システム4のユーザデータ送信部58は、周波数帯域f3で送信し、中央局システム2のユーザデータ受信部60は、周波数帯域f3で受信する。中央局システム2のユーザデータ送信部62は、チャンネルf4の下り回線を送信し、遠隔システム4のユーザデータ受信部64は、周波数帯域f4で受信する。このように、ネゴシエーションチャンネルとユーザチャンネルの情報交換は互いに独立して行われる。

【0073】本実施の形態において、通信パス(ネゴシエーションチャンネル)f1とf2の周波数帯域は通信パス(ユーザチャンネル)f3とf4の周波数帯域より低い。ネゴシエーションチャンネルにより低い周波数を用いるのは、周波数がより低ければエラーレートもより低くなるという観測結果からして、それがシステムにとって望ましいからである。ただし、(種々の通信パスの実際の周波数帯域とともに)このように帯域の割当てを行うことは、本発明の趣旨と範囲から逸脱しないかぎり変更することができる。

【0074】チャンネル検査信号は、確立される通信回線(接続)の通信能力を判定するために送信される。検査信号が複数の信号群を有するのであれば、各検査信号群は独立に送信されることが望ましい。本実施例では、信号群は二つ、すなわち、(1)基本チャンネル検査信号及び(2)オプションチャンネル検査信号とする。

【0075】通信パスf5(図5)は、通信チャンネルの回線特性を判定する基本チャンネル検査信号を送信する基本チャンネル検査信号帯域を有する。同様に、通信パスf6(図6)は、通信パスf5の周波数帯域よりも高い周波数帯域のオプションチャンネル検査信号をオプションで送信するためのオプションチャンネル検査信号帯域を有する。遠隔システム4のトーン信号生成部78は、通信パスf5及びf6で送信される検査信号を生成する。中央局システム2のトーン信号受信部80は、通信パスf5及びf6で検査信号を受信する。基本チャンネル検査信号とオプションチャンネル検査信号は、異なるタイミングで送信が開始される。

【0076】本実施の形態において、検査信号は特定の正弦トーン群の信号からなる。検査信号の特定の構成は、本発明の範囲と趣旨を逸脱しない限りにおいて、変

更することができる。例えば、検査信号は、複数の周波数、複数の信号、広域信号、ノイズ信号（特定の帯域の白色雑音等）あるいはスペクトラム拡散信号からなる純粋な正弦群から構成されてもよい。また、検査信号は異なる周波数の副周波数帯域で送信される複数の信号群から構成されていてもよい。更に、検査信号が複数の信号群で構成されている場合、信号の位相は異なってよい。

【0077】基本チャンネル検査信号は、通信接続開始時に送信される。オプションチャンネル検査信号（例えばオプションチャンネル検査信号帯域f6で送信される検査信号）は、基本チャンネル検査信号帯域の周波数帯域より高い周波数帯域でデータ通信を実行することができるかどうかを判定することが望ましい場合にかぎり送出される。しかしながら、本発明の範囲と趣旨を逸脱しない限りにおいて、基本チャンネル検査信号と同時に、オプションチャンネル検査信号の送信を開始してもよい。

【0078】遠隔システム4の擬似ランダムノイズ生成部74（2図）は、5図に示されるように、音声帯域（約0-4kHz）における通知信号を送信する。通知信号は、スプリッタの存在の検知及び音声帯域を用いる能力通知機能の検知を行う。この能力通知機能は、高速データ通信及び音声通信の少なくとも一方が利用可能であることを示すものである。通知信号の周波数（スペクトラム）に関しては、特定周波数信号（あるいはFM変調信号）の使用は好ましくない。例えば、ファクシミリ接続の為のT.30プロトコルにおけるCNG信号、V.8プロトコルにおけるCI信号等は、進行中の音声帯域通信と干渉する可聴信号を発生させてしまう。その為、本実施の形態においては、通知信号は、擬似ランダムノイズ等のスペクトラム拡散信号であることが好ましい。しかしながら、他のタイプの信号も使用できる。適正な電力値のスペクトラム拡散信号を用いることにより、音声通信と干渉する信号の受信を防ぐことができる。

【0079】本実施の形態では、通知信号は音声帯域でデータ通信能力が利用可能であることを示す表示信号を有する。この表示信号により、他の通信端末（例えば、遠隔システムが表示信号を送出している時の中央局システム2）は、高速データ通信機能が利用できるか識別できる。

【0080】通知信号は、更に、通信システムが周波数分離部（スプリッタ等）を使用しているかどうかを識別する為に用いることができる。通信システムにおいては、スプリッタを使用することにより、通信装置が高周波数ポートに接続されている時に、音声帯域信号を受信しないようにする。従って、通知信号の受信がない場合は、スプリッタがその通信システムに設置されていることを示している。

【0081】図3と図4のフローチャートを参照して以下を説明する。フローチャートには幾つかの判定ブラン

チがあるので、種々の工程の組み合わせが可能である。最初に模式的フロー、（すなわち、直線フロー）について、次にブランチを伴うフローについて説明する。手順（フローチャート）における経路は、設備配列（例えば、スプリッタが通信バスにあるか、両サイドが本発明を有するか、外部干渉が通信チャンネルの品質を低下させないか、等）に依存する。フローは関連通信装置間のネゴシエーションについて説明しているの、個々の関連装置の動作は図3と図4の間のピンポン（ジグザグ）方式で説明される。図3は、中央局システム2のテストネゴシエーションブロック46による処理であり、図4は遠隔システム4のテストネゴシエーションブロック48による処理である。

【0082】ステップ（以下STと略す）200において、所定周波数のパイロットトーン信号は遠隔システム4のネゴシエーションデータ送信部50によって送信される。同時に、擬似ランダムノイズが擬似ランダムノイズ生成部74によって送信される。

【0083】ST202において、中央局システム2は、ネゴシエーションデータ受信部52を用い、ネゴシエーション上り回線帯を検査し、上りパイロット信号が送信中であるか判定する。ネゴシエーション上りデータパイロット信号が検出されると、中央局システム2は、ネゴシエーションデータ送信部54を用い、下りネゴシエーションパイロット信号の送信を開始する。

【0084】ST208において、遠隔システム4は下りパイロットトーン信号を検出したかどうかを判定する。ST208において、下りパイロットトーン信号が遠隔システム4によって検出された場合、ST212が実行され、ネゴシエーションデータ送信部50は、上りネゴシエーションチャンネルf1を介して、上りネゴシエーションデータの送信を開始する。

【0085】ST214において、中央局システム2が有効データを検出すると、ネゴシエーションデータ送信部54は下りネゴシエーションチャンネルf2を介して下りネゴシエーションデータの送信を開始する。一方、中央局システム2が有効なデータを検出しない場合、データ検出動作は繰り返し実行される。

【0086】ST218において、遠隔システム4は有効なネゴシエーション下りデータが検出されたかどうかを判定する。遠隔システム4が有効データを検出すると、遠隔システム4のユーザデータ送信部58は上りユーザチャンネルf3を介して上りユーザデータの送信を開始する（ST220）。一方、遠隔システム4が有効データの検出に失敗すると、ST218は有効データが検出されるまで繰り返される。

【0087】遠隔システム4は、周波数帯f5（例えば、基本チャンネル検査信号チャンネル）の基本チャンネル検査信号（ST222）も送信する。この信号に応じて、中央局システム2は、回線特性の検査を開始する。

【0088】中央局システム2はユーザデータ受信部60で有効な上りユーザデータが検出されるかどうかを判定する(ST224)。ST224の結果が否定的である場合、このステップは肯定的な結果が出るまで繰り返し実行される。その時点で、処理はST226に移り、ユーザデータ送信部62は下りユーザチャンネルf4を介して下りユーザデータの送信を開始する。

【0089】次に、ST228が実行され、中央局システム2のトーン信号受信部80は、遠隔システム4のトーン信号生成部78によって発信された基本チャンネル検査信号の受信を開始する。

【0090】遠隔システム4において、ユーザデータ受信部64は有効な下りユーザデータを受信しているかどうかを判定する(ST230)。判定結果が否定的の場合、ST230は肯定的結果が出るまで再実行される。遠隔システム4が有効な下りユーザデータ(例えば肯定的判定結果)を受信した場合、すべての通信チャンネルが確立されている。

【0091】この時点でST232が実行され、遠隔システム4は、その通信能力と通信方法情報とを、上りネゴシエーションパスを介して繰り返し送信する。同時に、ST234が実行され、中央局システム2はその通信能力と希望する通信条件(例えばオプションチャンネル検査信号情報帯域f6(ST236)が使用できる等の表示)の送信を開始する。

【0092】遠隔システム4が、オプションチャンネル検査信号の使用を許可する表示を中央局システムから受信すると(ST236は肯定的)、遠隔システム4のトーン生成部78はオプションチャンネル検査信号の送信を開始する(ST238)。一方、ST236が否定的であると処理はST244に移行する。

【0093】その間、中央局システム2のトーン信号受信部80は、スペクトル情報を計算するために信号のスペクトル分析を実行し(ST240)、スペクトル情報は次に下りネゴシエーションパスf2を介して遠隔システム4に送信される(ST242)。

【0094】遠隔システム4は、スペクトル情報が受信されたらと判定するまでST244で待機する。スペクトル情報が受信されると、遠隔システム4は、分析を行い、能力、チャンネル制限等を判定し、使用する通信方法(規格)のタイプ(例えば、ADSL、CDSL等)に関する最終判定を行う(ST246)。次に遠隔システム4は、基本チャンネル検査信号(もし送信されているならオプションチャンネル検査信号も)の送信を停止する(ST248)。遠隔システム4は最終判定に関する(を示す)情報の送信を(上りネゴシエーションパスf1を用いて)繰り返す(ST250)。

【0095】中央局システム2は、遠隔システム4から最終判定に関する情報を受信したと判定するまで待機する(ST252)。中央局システム2が最終判定の受信

を検出すると、ST254が実行され下りネゴシエーションデータと下りユーザデータの送信を停止する。

【0096】遠隔システム4側では、遠隔システム4はエネルギー(キャリア)の減衰が検出されるまで待機し、その時点で、上りネゴシエーションデータおよび上りユーザデータの送信は停止される(ST258)。その後、遠隔システム4は所定の期間が終了するまで待機し(ST260)、その後、選択された高速通信システムタイプの手順の初期化が開始される。ネゴシエーション手順および高速初期化手順が完了後、中央局システム2と遠隔システム4の間で適切な高速通信チャンネルが利用可能となる。

【0097】中央局システム2のトーン信号受信部80が、ST202でパイロットトーン信号を検出できない場合、中央局システム2の擬似ランダムノイズ受信部76は、約0Hz~4kHzの音声帯域の擬似ランダムノイズが存在するか(検出されるか)ST204で判定する。擬似ランダムノイズが検出されると、従来の音声帯域データ通信が実行でき(ST206)、チャンネルは高速通信をサポートできないが機器は高速通信をサポートできるかようであると判定される。すなわち、本発明は、V.8、V.8bis、V.34プロトコル等の従来の音声帯域のフォールバック通信接続を行うと判定する。擬似ランダムノイズが検出されない場合、ST202はパイロットトーン信号をもう一度検出するために再実行される。このように、音声帯域内で通知信号(擬似ランダムノイズ等)を発信し、通知信号を受信できるかどうかを判定することによって、高速データ通信機能が利用可能かどうかを判定することができる。

【0098】しかしながら、もし高速データ通信が実行できなければ、本発明は、音声帯域通信手順へフォールバックするようにしている。例えば、高速データ通信を実行しない時は、V.34プロトコルを使用してデータ通信を行うことができる。ST208において、下りパイロットトーン信号が検出されない場合は、ST210が実行され、遠隔システム4が音声帯域手順(V.8、V.8bis等)あるいは代わりの高速手順を開始する。

【0099】要約すれば、ネゴシエーションブロック46及び48は、通信チャンネルと関連機器(中央局システム側と遠隔システム側の両サイドにおける)を解析し、適切な通信規格を選択する。

【0100】図6は、本発明の実施の形態1に係る装置の概念図を示す。中央局システムスプリット304は、LPF34及びHPF38を有し、図2に示したテストネゴシエーションブロック46の各ブロック及びxTUC302で図示されるモデム68及び70に信号を供給する。PSTNスイッチ300は、チャンネル5に接続される。電話306は、便宜上、図2に示す音声チャンネル33に接続されている。しかしながら、本発明の範囲

と趣旨から離脱しないかぎり、電話306は、音声チャネル32に接続することができる。種々の変形を本実施の形態に対して加えることができる。図7から図12は、変更された概略ブロック図を示すが、本発明はこの実施形態に制限されない。実施の形態1と同一の構成要素には、同一の参照番号が付されている。

【0101】図7及び図8は、本発明の実施の形態2を示す。本実施の形態では、本発明は遠隔システム4のみで実行され、中央局システム2は高速通信互換性が無い。遠隔システム4が中央局システム2と接続しようとすると、ST208(図4)において下りパイロット信号が検出できない。その結果、ST210で音声手順を開始される。図7に示すように、チャネル5は、PSTNスイッチ300に送信する音声帯域信号を示す。

【0102】図示されていないが、本実施の形態の変更としては、中央局システム2が本発明を実施し、遠隔システム端末4が高速データ通信を使用しない場合が考えられる。

【0103】この状況では、中央局システム2は、ST202で、上りパイロットトーンを検出できないが、疑似乱数信号を検出すると、ST206で音声帯域手順を開始する。同様に、中央局システム2は、ST202で上りパイロットトーンを検出できず、ST204で疑似乱数信号も検出できないと、一定時間後に音声帯域手順を開始する。図9と図10に本発明の実施の形態3を示す。本実施の形態は、遠隔システム側のxタイプの送信ユニット(xTUR)350を電話(網)306から分離するために、遠隔システムのスプリッタ86が遠隔システム4に設けられている点で実施の形態1と異なる。この構成においては、スプリッタ86を用いることにより高速帯域と音声帯域とのスペクトラム間の干渉は著しく減少し、xTU0C(302)とxTUR(350)の性能は改良される。図10に示すように、スプリッタ86は低域フィルタ88と高域フィルタ90を備える。

【0104】本実施の形態において、疑似ランダムノイズは高域フィルタ90を通過しない。従って、中央局システム2の疑似ランダムノイズ受信部76は、これはスプリッタが存在することを示す、遠隔システム4によって生成された疑似ランダムノイズを受信しないこととなる。この情報はネゴシエーション期間に交換される。その結果、スプリッタフィルターの検出は、自動的に行われ表示される。

【0105】本実施の形態では、電話306(図9)はチャネル33(図10)に接続されている。図9の中央局システム2の構成は、図6の中央局システム2の構成と同じである。

【0106】本発明の実施の形態4を図11に示す。本実施の形態において、インテリジェントスイッチ314は、テストネゴシエーションブロック46で実行される

機能を有し、適切なxTU-C(316あるいは318等)を選択し、選択された通信規格(ADSL、VDSL、ISDN、V.34等)を確立する。

【0107】本発明の実施の形態5を図12に示す。本実施の形態において、中央局システム2は、複数の部分(例えば第1部分320、第2部分322)に分割され、通信動作は複数のサービスプロバイダによって実行することができる。各部分の構成は本質的に図9に示す構成と同じである。第1部分320及び第2部分322は、前述した実施の形態のいずれかと同様に構成されている。既に述べたように、スプリッタ304及び328は、高速通信から音声帯域信号を分離する為に設置される。

【0108】本実施の形態によれば、公衆電話回線網(PSTN)スイッチ300及び326と、xTU-Cユニット302及び330とは、特定のサービスを提供するサービスプロバイダによって構成される。遠隔システムがサービスの要求を開始した時、(下りネゴシエーションデータの送信に対応する上りネゴシエーションデータにより判定されたような)所望のサービスを提供できるシステムだけが遠隔システムに接続される。

【0109】本発明では、複数の通信規格の中から、使用すべき最適通信規格を迅速かつ効果的に判定する。特に、本発明では、複数の通信規格から一つの通信規格を効率的に選択し、チャネル特性を判定、明確にしたのち使用し、また通信パスにおけるスプリッタの有無を無理なく判定することができる。これらにより、高速通信パスが利用可能になる前に、ユーザデータを中央局システムと遠隔システム間で交換することができる。

【0110】本発明では、データ通信はネゴシエーション手順と同時に開始してもよい。すなわち、ユーザ通信(データ通信等)は、回線検査とネゴシエーション動作と同時に行うことが可能である。しかしながら、ユーザ通信の送信は、本発明の趣旨と範囲から逸脱しないかぎり、ネゴシエーション動作実施後に開始することもできる。

【0111】本発明は特定の手段、材料、機器を取り上げて説明したが、本発明はここに開示した事項に限定されるものではなく、請求の範囲の同等なあらゆる状況に適用される。例えば、コンピュータ82及び84は、通信チャネル5を介して送信されるデータ信号を生成する他の装置(ネットワーク機器等)により代替することができる。

【0112】

【発明の効果】以上の説明から明らかなように、本発明によれば、既存の通信環境に影響を及ぼすことなく、2つの通信システム間で、ネゴシエーション、ユーザデータの交換を行うとともに、回線特性の検査を行い、通信回線に適した通信規格、データ通信手順を短時間で決定することができる。

【図面の簡単な説明】

【図1】本発明の実施の形態1に係る通信装置を使用したデータ通信システムのブロック図

【図2】実施の形態1に係るデータ通信システムの具体的な構成を示すブロック図

【図3】実施の形態1に係るデータ通信システムの中央局システム側における動作を示すフロー図

【図4】実施の形態1に係るデータ通信システムの遠隔システム側における動作を示すフロー図

【図5】実施の形態1に係るデータ通信システムにおいて使用されるスペクトル分布を示す概略図

【図6】実施の形態1に係るデータ通信システムを示す概略ブロック図

【図7】本発明の実施の形態2に係る通信装置を使用したデータ通信システムを示す概略ブロック図

【図8】実施の形態2に係るデータ通信システムの具体的な構成を示すブロック図

【図9】本発明の実施の形態3に係る通信装置を使用したデータ通信システムを示す概略ブロック図

【図10】実施の形態3に係るデータ通信システムの具体的な構成を示すブロック図

【図11】本発明の実施の形態4に係る通信装置を使用したデータ通信システムの概略ブロック図

【図12】本発明の実施の形態5に係る通信装置を使用したデータ通信システムの概略ブロック図

【符号の説明】

- 1 メイン分配フレーム (MDF)
- 2 中央局システム
- 3 ネットワークインタフェースデバイス (NID)
- 4 遠隔システム
- 5 通信チャンネル
- 34, 36 低域フィルタ
- 38, 40 高域フィルタ
- 46, 48 テストネゴシエーションブロック

【図1】

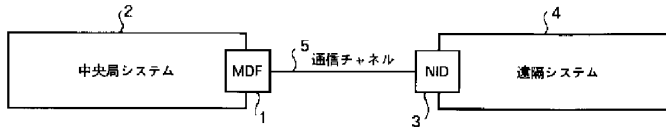

【図2】

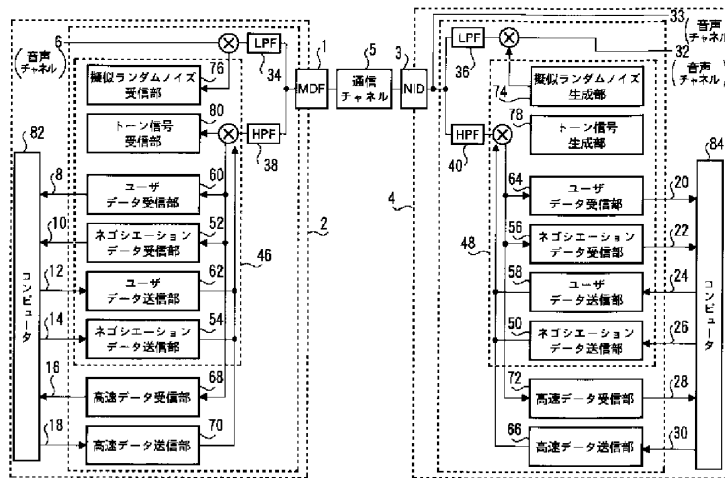

【図3】

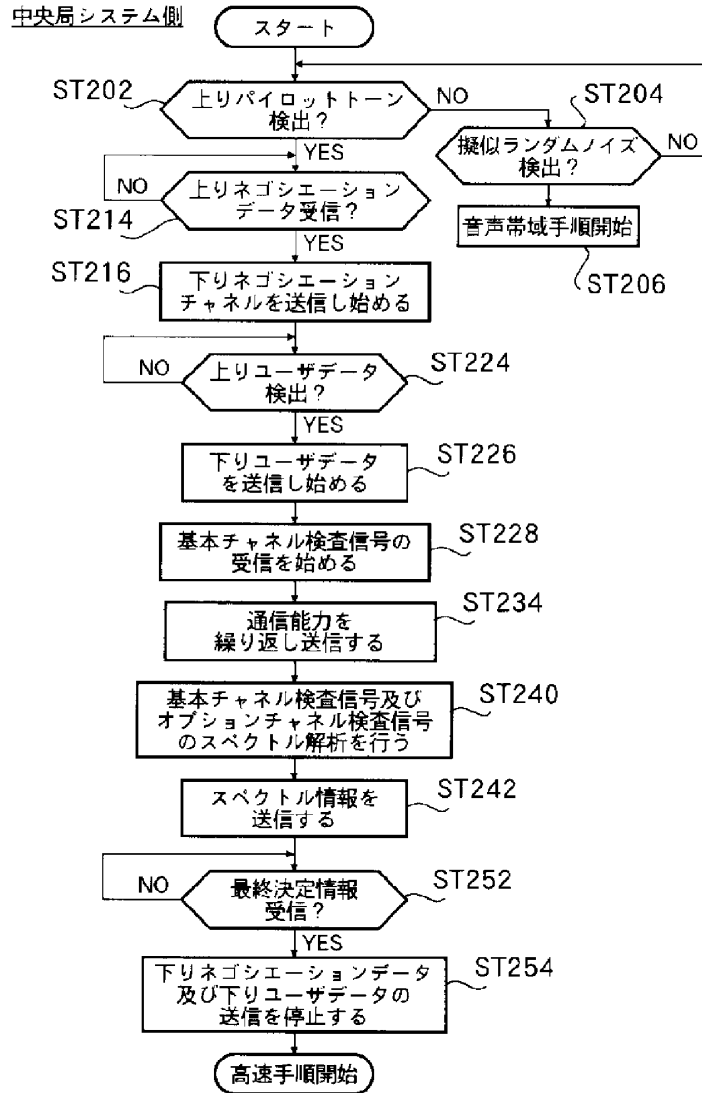

【図4】

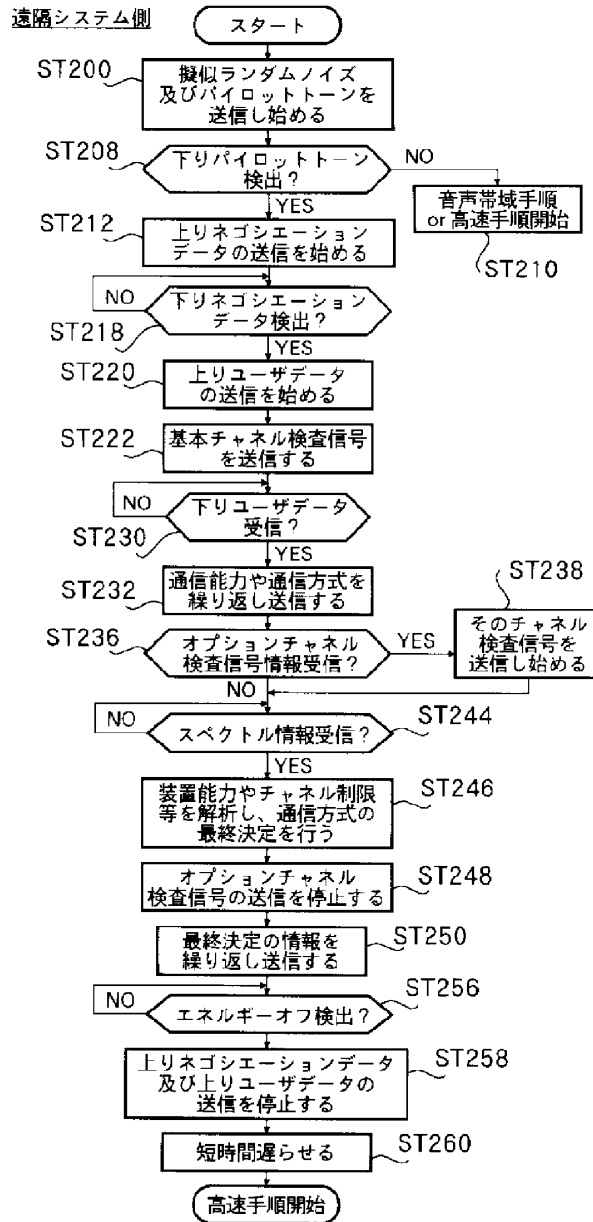

【図5】

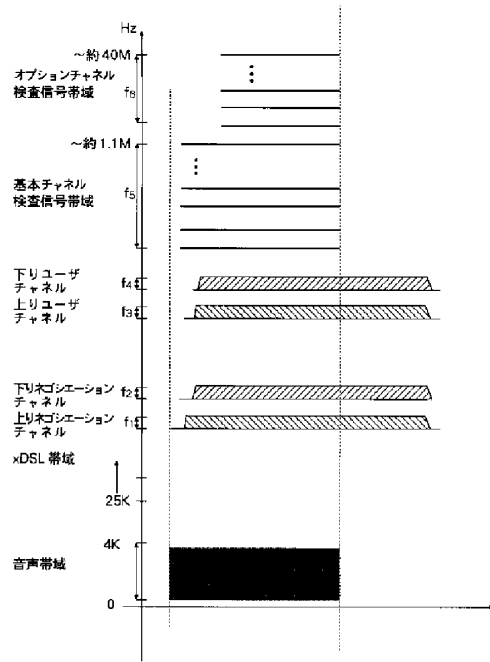

【図6】

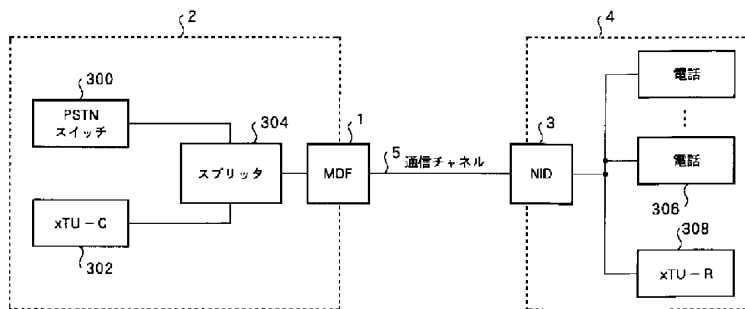

【図7】

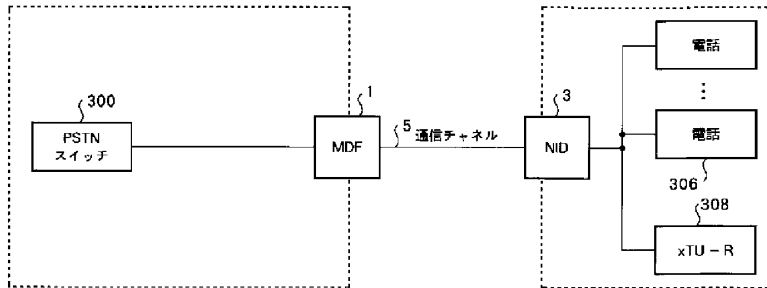

【図8】

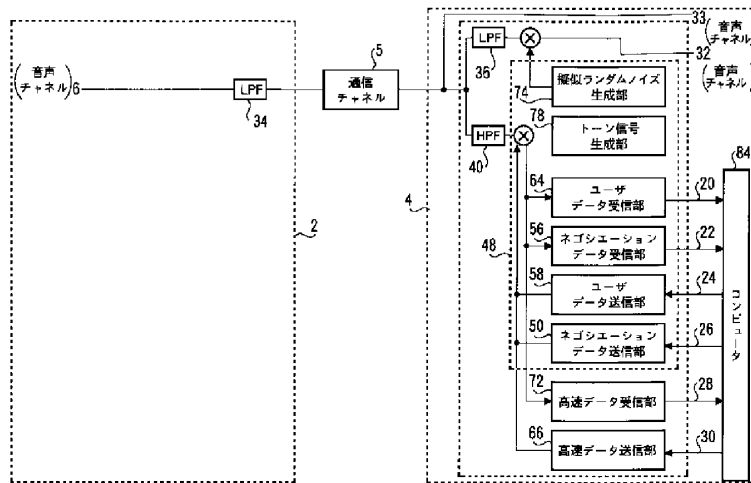

【図9】

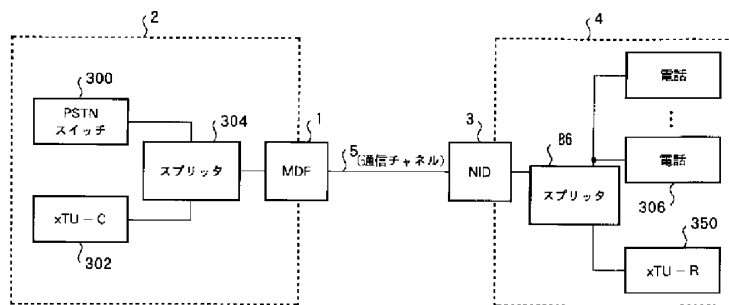

【図10】

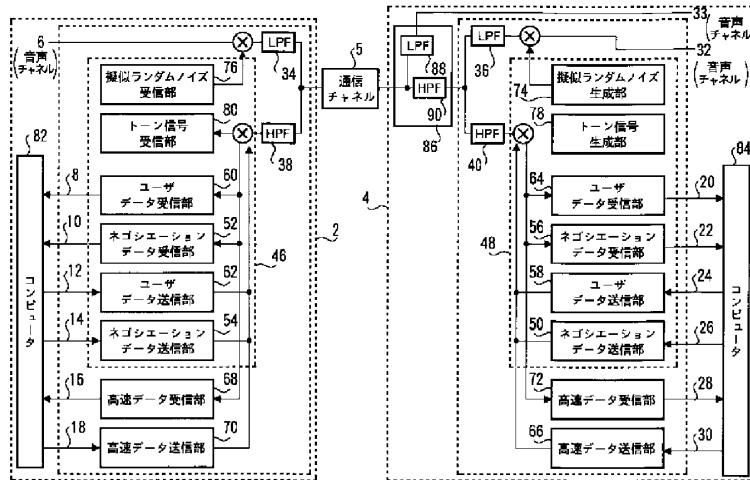

【図11】

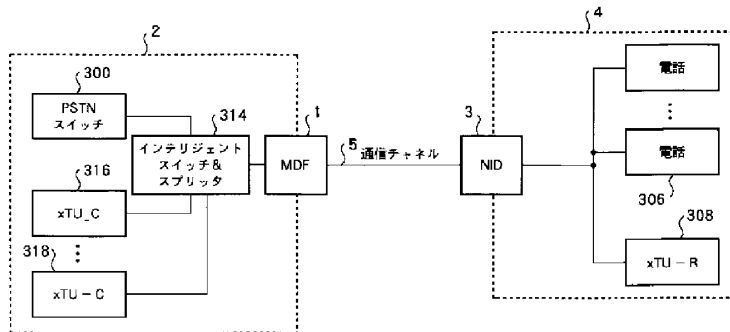

【図12】

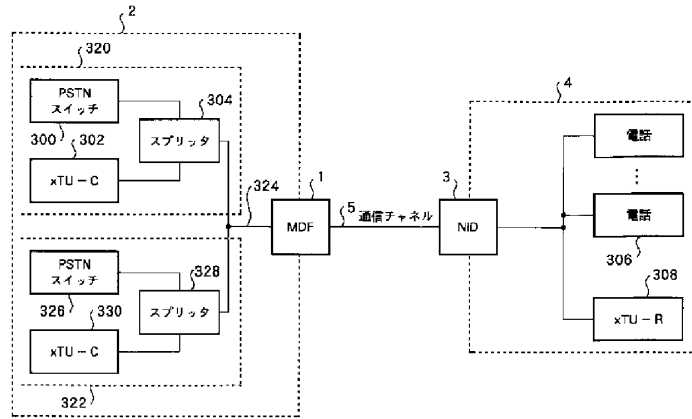

PATENT ABSTRACTS OF JAPAN

(11)Publication number : 11-317723
 (43)Date of publication of application : 16.11.1999

(51)Int.Cl. H04J 11/00
 H04L 29/08
 H04M 3/00
 H04M 11/00

(21)Application number : 11-004993 (71)Applicant : MOTOROLA INC
 (22)Date of filing : 12.01.1999 (72)Inventor : LEVIN HOWARD E
 MAY MICHAEL R
 PENDLETON MATTHEW A
 JOHNSON TERENCE

(30)Priority
 Priority number : 98 7218 Priority date : 14.01.1998 Priority country : US
 98 7390 14.01.1998 US

(54) METHOD FOR ASSIGNING DATA AND POWER IN DISCRETE MULTI-TONED COMMUNICATION SYSTEM

(57)Abstract:

PROBLEM TO BE SOLVED: To optimize the power consumption of a discrete multi-toned(DMT) system by reducing power with respect to a not-using carrier among plural carriers assigned with bits.

SOLUTION: Data transmitted to a remote terminal 20 through a transmission medium 15 by a telephone station 30 is received by a transmitter/receiver 24 and given to a system controller 22 to process. In addition, an upstream signal from the terminal 20 is also processed by a system controller 34 through the transmitter/receiver 32 of the station 30. Then, carriers, namely bins, are sorted in an order from a maximum capacity to a minimum capacity to advance from the carrier of the maximum capacity to that of the minimum capacity to assign a transmission data rate and a data capacity is assigned until a designated data rate is obtained. Since a maximum data rate is assigned to a bin at first, the number of using carriers for transmitting data by a desired data rate is minimized to minimize power on an unused carrier. Thereby, an optimum power quantity can be dissipated.

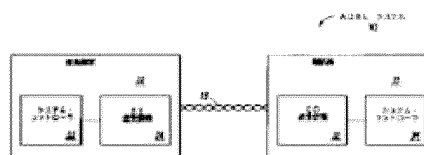

(51)Int.Cl. ⁶	識別記号	F I
H 0 4 J 11/00		H 0 4 J 11/00 Z
H 0 4 L 29/08		H 0 4 M 3/00 B
H 0 4 M 3/00		11/00 3 0 2
11/00	3 0 2	H 0 4 L 13/00 3 0 7 Z

審査請求 未請求 請求項の数5 OL (全 11 頁)

(21)出願番号	特願平11-4993	(71)出願人	390009597 モトローラ・インコーポレイテッド MOTOROLA INCORPORATED
(22)出願日	平成11年(1999)1月12日	(72)発明者	アメリカ合衆国イリノイ州シャンバーグ、 イースト・アルゴンクイン・ロード1303 ハワード・イー・レビン
(31)優先権主張番号	0 0 7 2 1 8	(72)発明者	アメリカ合衆国テキサス州オースチン、パ ラマウント・アベニュー2103 マイケル・アール・メイ
(32)優先日	1998年1月14日	(72)発明者	アメリカ合衆国テキサス州オースチン、ロ チェスター・レーン13110
(33)優先権主張国	米国 (US)	(74)代理人	弁理士 大貫 進介 (外1名)
(31)優先権主張番号	0 0 7 3 9 0		最終頁に続く
(32)優先日	1998年1月14日		
(33)優先権主張国	米国 (US)		

(54)【発明の名称】 離散マルチ・トーン通信システムにおいてデータおよびパワーを割り当てる方法

(57)【要約】

【課題】 離散マルチ・トーン (DMT) 通信システムにおいてパワー消費の最適化を図るデータおよびパワー割り当て方法を提供する。

【解決手段】 ビット割り当て容量にしたがって、キャリアをソートする。次に、最大のビット割り当て容量を有するキャリアから最少のビット割り当て容量を有するキャリアの順に、全てのビットを割り当てるまで指定のビット・レートを得るために必要なビット数を割り当てる。割り当て後、使用されていないビンのパワーを全て削減する。使用されていないピンは劣悪なピンを含み、データを宛先に確実に送信できないキャリアとして識別する。マージナル・ピンは、データを宛先に送信可能となり得るキャリアとして識別する。劣悪なビンのパワーを削減し、マージナルまたは良好なピンに割り当て、ビット・レートの上昇を可能にする。または、マージナル・ビンのパワーを削減し、良好なピンに割り当てる。

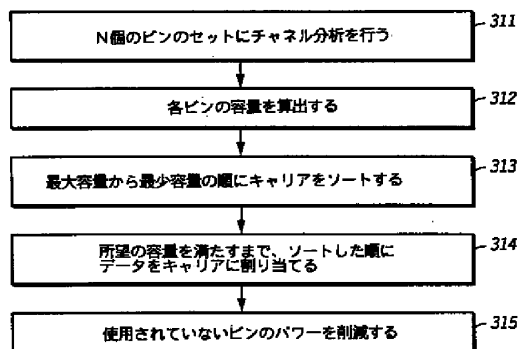

【特許請求の範囲】

【請求項1】離散マルチ・トーン通信システムを構成する方法であって：複数のキャリア上においてチャンネルの分析を行う段階；前記複数のキャリアの一部にデータ容量を割り当てる段階であって、ビットを割り当てられた前記複数のキャリアの前記一部は使用中のキャリアであり、前記複数のキャリアの内ビットが割り当てられない一部は、使用されていないキャリアを含む段階；および前記使用されていないキャリアに対するパワーを削減する段階；から成ることを特徴とする方法。

【請求項2】前記使用されていないキャリアは、所定の性能基準を満たさないことを特徴とする請求項1記載の方法。

【請求項3】前記所定の性能基準は、指定されたエラー率以下の所定のデータ・レートを指定することを特徴とする請求項2記載の方法。

【請求項4】前記複数のキャリアをソートし、ソート・リストを作成し、ビット・ローディング容量にしたがって、前記ソート・リストをソートする段階；を更に含み；前記チャンネルの分析を行う段階は、ビット・ローディング容量を判定する段階を含み、前記データ容量を前記複数のキャリアに割り当てるステップは、前記データ容量の全てを割り当てるまで、前記ソート・リストにしたがって使用中のキャリアに前記データを割り当てる段階を更に含み、最大のビット・ローディング容量を有するビン、最大のビット・ローディング容量未満を有するビンの前に、完全に充填されることを特徴とする請求項1記載の方法。

【請求項5】前記使用中のキャリアの少なくとも1つに対するパワーを増大させる段階を更に含むことを特徴とする請求項1記載の方法。

【発明の詳細な説明】

【0001】

【発明の属する技術分野】本発明は、一般的に、通信システムに関し、更に特定すれば、離散マルチ・トーン・システム(discrete multi-tone communication system)を構成する方法に関するものである。

【0002】

【従来の技術】テレビ会議(video conferencing)やインターネット・アクセスのような、高データ・レート双方向サービスを、住宅および小規模事務所の顧客にも一層入手し易くするためには、高速データ通信経路が必要である。かかる高データ・レートサービスには光ファイバ・ケーブルが最適な伝送媒体であるが、既存の通信ネットワークにおいては容易に使用することができず、光ファイバ・ケーブルを設置する費用は法外に高い。現行の電話配線接続は、ツイストペア媒体で構成されており、ビデオ・オン・デマンドのような双方向サービス、またはそれよりも更に高速な相互接続に必要な高データ・レートに対応するように設計されたものはない。これに

対して、非対称デジタル加入者回線(ADSL: Asymmetrical Digital Subscriber Line)技術が開発され、既存のツイストペア接続の固定帯域幅以内で伝送能力を向上させることにより、新たな光ファイバ・ケーブルの設置を必要とすることなく、双方向サービスの提供を可能にした。

【0003】離散マルチ・トーン(DMT: Discrete Multi-Toned)とは、ツイストペア接続のような通信チャンネルの使用可能帯域幅を、多数の周波数サブチャンネルに分割するマルチ・キャリア技術のことである。これらのサブチャンネルは、周波数ビン(frequency bin)またはキャリアとも呼ばれている。DMT技術は、ANSI T1E1.4(ADSL)委員会によって、ADSLシステムに用いるために採用されている。ADSLでは、DMTを用いて、エンド・ユーザに向かう下流伝送に26kHzから1.1MHzまでの250個の別個の4.3125kHzサブチャンネルを発生し、エンドユーザによる上流伝送のために26kHzから138kHzまでの25個のサブチャンネルを発生する。各ビンには、各伝送と共に送るある数のビットが割り当てられる。ADSLシステムに対してビン毎に割り当てられるビット数は、0、および2ないし15ビットである。

【0004】ADSLシステムを用いてリアル・タイム・データを送信する前に、初期化プロセスを行う。初期化プロセスの第1部分の間、活性化および承認ステップを行う。ADSLシステムの電力投入に続いて送信活性化トーンを発生するのは、このステップの間である。送受信機トレーニングは、初期化プロセス中の次のステップである。送受信機トレーニングの間、ADSLシステムの等化フィルタをトレーニングし、システムの同期を得る。次に、初期化プロセスの一部として、チャンネル分析および交換を行う。チャンネル分析および交換の間、チャンネルの信号対ノイズ比(SNR)を判定し、ビンのビット・ローディング・コンフィギュレーション(bit loading configuration)およびその他のコンフィギュレーション情報を転送する。

【0005】初期化プロセスに続いて、リアル・タイム・データ送信が開始する。リアル・タイム・データ送信の間、提案されているANSI規格の実施態様は、各キャリアを公称パワー量(nominal amount of power)で送信することを要求する。公称パワー量は、最大パワー量となるように提案されており、これは、パワー利得微調整のばらつきがキャリア間で発生するだけで、全てのビン全体に対してほぼ同一である。しかしながら、公称送信パワー量を各キャリアに割り当てることには欠点がある。例えば、1つの問題は、データを全く送信していないキャリアに公称パワー量を割り当てることに伴い、不要のパワー消費が生ずることである。これが発生するのは、要求されたデータ・レートが、回線上で使用可能な最大データ・レート未満の場合である。この余分なパワ

一のために、パワー消費に関してシステムに余分なコストがかかることになる。未使用ビンにパワーを送信することに対する他の問題は、キャリアの信号が長い回線距離の間に減衰するために、所望の確実性でデータを送信できない地点が生ずることである。これが発生すると、劣悪なビンのビット割り当て容量が0にセットされるが、しかしながら、提案されている仕様の実施態様の下では、その送信パワーは、現在使用されていないビンにも割り当てられ続ける。したがって、高データ・レートがない場合でも、パワー・コストが高くなる。ADSL仕様に伴う他の問題は、隣接する回線上において同様の周波数で信号を送信している場合、クロストーク干渉が発生することである。

【0006】

【発明が解決しようとする課題】典型的なDMTシステムでは、その消費パワーの概ね半分以上が、回線ドライバによって消費される。パワー増大に伴う熱の問題に加えて、隣接する電話回線からのクロストークが回線ノイズ・レベルを40 dBにも高める可能性があるという、更に別の問題がある。したがって、DMTシステムのパワー消費を最適化し、隣接するツイストペアワイヤ間のクロストークを減少させることができれば有利であろう。

【0007】

【発明の実施の形態】図1は、ADSLシステム10を示す。ADSLシステム10は、遠隔端末20、およびツイストペア伝送媒体によって接続されている電話局(central office)30を備える。遠隔端末20および電話局30は、各々、システム・コントローラ22、34をそれぞれ備えている。加えて、遠隔端末20および電話局30は、それぞれ、送受信機24、32を備えている。ADSLシステム10は、本発明を実施することができる。動作の間、電話局30は、伝送媒体15を通じて、下流データを遠隔端末20に送信する。データは、遠隔端末20の送受信機24によって受信され、送受信機24は受信データをシステム・コントローラ22に供給し、更に処理を進める。同様に、上流信号も遠隔端末20から伝送媒体15を通じて送信され、電話局の送受信機32によって受信され、送受信機32はシステム・コントローラ34にデータを供給する。

【0008】図2は、ADSLシステム10内で使用するためのSNR参照表を示す。SNR参照表は、あるビンが特定数のビットを特定のビット・エラー率(BER)で送信するために必要なSNRである、SNR_{ref}を示す。例えば、図2の表によれば、SNRが30であると判定されたビンは、7ビットのデータを送信することができる。また、必要であれば、使用するエラー補正の種類に応じてSNR参照表の値を変化させる。例えば、エラー訂正の使用により、図2における各SNR_{ref}の値を3小さくすることができる。この減少によ

り、SNRが30のビンは8ビットを送信することが可能となる。一般に、SNR参照表は経験的に得られるが、シミュレーションまたは理論的な結果に基づいて導出することも可能である。

【0009】図3は、本発明を実施する方法を示す。この特定実施例は、特定のDMTの実施態様を対象とするが、本発明はあらゆるDMTの実施態様にも適用されることは理解されよう。ステップ311において、ADSLチャンネルの分析を行う。本発明の一実施例では、チャンネル分析ステップ311は、初期状態におけるチャンネルに対する信号対ノイズ比(SNR)を返す。通常、図3のチャンネル分析ステップ311は、初期化プロセスの一部として実行する。しかしながら、図3のステップをリアル・タイム処理の間に実行する他の実施態様も、本発明によって予見される。

【0010】ステップ312において、各ビンのデータ容量を算出する。一実施例では、データ容量は、ステップ311において判定したキャリアのSNR、および図2のSNR参照表に基づいて算出する。データ容量は、所与のSNR参照表について、送信可能な最大ビット数を識別することによって、判定することができる。例えば、図2の表によれば、SNRが32のビンに割り当て可能な最大ビット数は、7ビットである。

【0011】次に、ステップ313において、最大容量から最少容量の順に、キャリア即ちビンにソートする。次に、ステップ314において、最大容量を有するキャリア(群)から始め、最少容量を有するキャリア(群)に進みつつ、送信すべきデータ・レートを割り当てる。指定したデータ・レートが得られるまで、データ容量を割り当てる。最初に最大データ・レートをこれらのビンに割り当てることにより、所望のデータ・レートでデータを送信するために使用するキャリア(使用キャリア)の数を最少に抑えることが可能となる。ステップ315において、未使用キャリア上のパワーを削減し、指定量の情報を送信するために用いられるパワーを最低に減らす。概して、使用中のビンのパワーの大きさの少なくとも1桁だけ、パワーを削減する。これは、各チャンネルが使用中であるか否かには係らず、公称パワー量を各チャンネルが維持しなければならない従来技術に対する利点である。使用していないビンに対するパワーを削減することにより、最適なパワー量の散逸が可能となる。

【0012】図4は、本発明の異なる実施例を示す。ステップ411において、1セットのキャリアNに対して、サブセット・キャリアXを指定する。サブセットXは、全体として、ビット・ローディング割り当てプロセスの間に好ましいキャリアまたは避けるべきキャリアを表す。次に、サブセットXに重み付けを行う。重み付けは、明示的とすることにより、ユーザが重み値を指定することや、あるいは暗示的とすることにより、システムがサブセットXにデフォルトの重みを有することも可能

である。例えば、サブセットXは、暗示的に重い重み付けを行うことも可能である。重みの機能については、ステップ415を参照しながら論ずることとする。

【0013】ステップ412において、セットNの各キャリアについて、チャンネル分析を行う。ステップ412のチャンネル分析は、既に論じた、図3のステップ311のチャンネル分析と同様に行う。次に、ステップ413において、キャリア・セットN内の各ビンに対するビット・ローディング容量を算出する。このステップは、図3のステップ312と同様である。ステップ414において、セットXの中に含まれないセットNのキャリアを、最大ビット・ローディング容量から最少ビット・ローディング容量の順にソートし、ソートしたキャリア・サブセットを形成する。このステップは、セットのサブセットに対して行われることを除いて、図3のステップ313と同様である。ステップ419において、セットX内のキャリアを、更に、最大ビット・ローディング容量から最少ビット・ローディング容量の順にソートし、別のソート・サブセットを形成する。代替実施例では、セットXをソートしなくてもよい。

【0014】ステップ415において、キャリア・サブセットXに関連するビンを、ソートしたキャリアのセットに挿入するか、あるいはこれから除外する。一実施例では、セットXのビンに暗示的に重い重み付けが行われている場合、そのセットは、ある予め規定された基準を満たすビンの前または後のソート・セット内に配置する。例えば、重い重み付けが行われたビンは、最大容量のビンの前に配置することができる。別の実施例では、重い重み付けが行われたビンは、10ビットの容量を有するビンと、9ビットの容量を有するビンとの間に配置することができる。通常、重い重み付けが行われたセットには、大きなビット割り当て容量を有するビンを挿入する。1つのビンに対する最大ローディングが15ビットである一実施例では、重い重み付けが行われたセットは、通常、7ビット割り当てレベル以上に挿入する。

【0015】同様に、セットXのビンに暗示的に軽い重み付けが行われている場合、これらを全体的にソート・リストから除外し、最少のビット・ローディング容量を有するビンの後に挿入するか、あるいは指定されたローディング・レベルを有するビン間に挿入することができる。通常、軽い重み付けが行われたセットには、ビット割り当て容量が小さいビンを挿入する。1つのビンに対する最大ローディングが15ビットである一実施例では、軽い重み付けが行われたセットは、通常、7ビット割り当てレベルより下に挿入する。

【0016】数値的な重み付けを適用する実施例では、重みの値に基づいて、セットXのビンを正確に配置または除外する。

【0017】ステップ416において、指定したデータ・レートに対応するために必要なビット数が、セットの

ソート順に基づいて、ビンに割り当てられる。例えば、セットXを、ローディング容量が13ビットのビンと14ビットのビンとの間に挿入すると仮定する。割り当ては、セットX内になく、ローディング容量が15ビットのビンから開始する。一旦最初のビンに15ビットが割り当てられたなら、セット内になく、ローディング容量が15ビットの別のビンに、15ビットを割り当て、以下全ての15ビット・ビンが完全に割り当てられるまで続ける。次に、同様に、セットX内にはない全ての14ビット・ビンを充填する。次に、セットX内にはない全ての13ビット容量のビンのローディングの前に、セットXのビットを充填する。セットXの各ビンを充填することに続いて、13ビット容量のビンについて、充填プロセスを続ける。

【0018】図5は、隣接する回線間のクロストークを減少可能な、本発明の別の実施例を示す。ステップ501において、キャリアのサブセットX1を、第1回線カードに指定する。ステップ502において、図4のフローをサブセットX1に適用する。これは、特定のデータ・レートに対応するために駆動する必要がある回線カード2のキャリア数を、事実上に最少に抑える。

【0019】ステップ503において、実質的に重複していないキャリアX2のサブセットを、第1回線カードに指定する。一実施例では、セットX1、X2は、異なる周波数で動作するビンにデータ容量を割り当てようとするという点で、相互に排他的である。更に他の実施例では、セットX1、X2は、互いに別個の回線カード内において使用されるビンをバッファするように選択する。例えば、セットX1がビン1ないし10を最初に充填すべきビンとして指定した場合、セットX2は、ビン12ないし21を最初に充填すべきビンとして示す。指定されたビンの中でビット・ローディング容量を割り当て可能である範囲において、セットX1、X2の周波数範囲をバッファする、未使用のビン、即ち、ビン11がある。このバッファリングによって、クロストークに対する抵抗力(immunity)強化が可能となる。

【0020】一旦セットX2を規定したなら、図4の方法を適用し、システムのパワーを最適化する。ステップ505において、データ送信を行うと、パワー散逸の最適化および隣接する回線間のクロストーク制限が可能となる。

【0021】図6ないし図9は、本発明を実施する他の方法を示す。図6のステップ601において、ADSLチャンネルの分析を行う。一実施例では、チャンネル分析は、初期状態におけるあるチャンネルのSNRを返す。通常、チャンネル分析および図6のステップは、初期化プロセスの一部として行われる。しかしながら、図6のステップをリアル・タイムで実行する他の実施態様も、本発明によって予見される。

【0022】チャンネル分析ステップからのSNR値に基

づいて、ステップ602において、当該チャネルに関連するどのビンが良好なビンかについて判定を行う。良好なビンとは、最少量のデータを送信可能な、予め規定されたSNRを満足するビンと定義する。例えば、表2のSNR基準(SNR_{ref})値は、ビンに2ビットのデータを割り当て、かつ特定のBERを維持するためには、ビンは少なくとも14のSNRを有する必要があることを示す。SNRが14未満のチャネルがある場合、最小数のビットを送信するものの、表のBERを維持することができないチャネルであることを示す。通常、ビンが予め規定されたBERを満たしつつ、最少量のデータを送信可能であれば、良好なビンとして定義される。

【0023】次に、ステップ603において、チャネル内の劣悪なビンを全て識別する。劣悪なビンとは、予め規定された性能基準を満たすことができないビンのことである。一実施例では、特定のキャリアについて、予め規定されたBERの範囲内でデータを送信できないと判定された場合、劣悪なビンとして識別される。通常、この識別を得るには、特定のチャネルのSNRを、最小値の送信量のSNR_{ref}と比較し、指定された基準が満たされるか否かについて判定を行う。例えば、SNRからSNR_{ref}を減じて-5以下となるキャリアを全て、劣悪なビンとするという基準が考えられる。したがって、図2の表を用いる場合、SNRが9以下である全てのチャネルが、劣悪なビンとして分類されることになる。通常、劣悪なビンには、データを全く割り当てることができない。

【0024】次に、ステップ604において、マージナル・ビン(marginal bin)のセットを識別する。マージナル・ビンのサブセットとは、以前に良好なビンとも劣悪なビンとも判定されていないビンと定義する。前述の例では、マージナル・ビンは、9ないし14のSNR値を有する。その理由は、SNRが14以上のキャリアは良好なキャリアであり、SNRが9以下のキャリアは劣悪なビンとするからである。マージナル・ビンには、他の定義も同様に使用可能である。例えば、5ビットを搬送できないビンを全てマージナル・ビンとして定義したり、あるいはSNR_{ref}値間の間隔に基づいて定義することが望ましい場合もある。

【0025】次に、ステップ605において、劣悪なビンに割り当てた送信パワーを削減する。固定量だけパワーを削減したり、あるいは倍率に基づいてパワーを削減することができる。劣悪なビンの送信パワーを固定量だけ削減させる一例としては、フィルタ応答を変化させ、劣悪なビンを減衰させることである。倍率によって劣悪なビンのパワーを削減させる一例は、その周波数領域におけるキャリアに0.10を乗算することであろう。劣悪なビンに関連する送信パワーを削減することにより、データが送信される可能性がない場合、使用パワーが減少する。これは、全てのビン上で送信パワーを維持する

ことを指定する、またはマージナル・ビン上では少量のデータを送信することを提案する従来技術の方法に対する利点である。

【0026】次に、ステップ606において、マージナル・ビン上のパワーを増大させる。通常、劣悪なビンのパワーを削減することによって得られる量だけ、マージナル・ビンのパワーを増大させることにより、システム全体のパワーには変化を生じさせない。一実施例では、得られるパワーは、全てのマージナル・ビンに均等に与えるように使用する。他の例では、得られるパワーは、各ビンのSNRに基づいて、いずれかのマージナル・ビンに割り当てることも可能である。更に別の実施例では、割り当てられるパワーに対して最大のビット容量増加を得ることができるマージナル・ビンに、得られたパワーを追加する。

【0027】次に、ステップ620において、パワー・レベルが上昇した各マージナル・ビンについて、パワー増大の結果、マージナル・ビンが良好なビンとなったか否かについて判定を行う。この判定は、マージナル・ビンに対するチャネル分析によって推定または決定し、送信パワー増大後のSNR値が、データ転送に対応するのに充分か否かについて判定を行うことができる。マージナル・ビンが改善され、良好なビンと判定された場合、フローはステップ607に進み、新たに識別された良好なビンを、そのように識別する。マージナル・ビンのパワーが増大したものの、未だマージナルであると判定された場合、フローはステップ608に進む。ステップ608において、このビンを劣悪なビンとして識別し、フローはステップ305に進み、ここで新たに識別された劣悪なビンのパワーを削減する。尚、ステップ608において、ビンのマージナル・ステータスを維持し、更にパワーを増大し、良好なビンを作成しようとすることも可能である。しかしながら、マージナル・ビンの少なくともいくつかを劣悪なビンとして識別し、割り当てのために余分なパワーを解放してマージナル・ビンのSNRを改善するために使用し、ステップ608において劣悪なビンとして識別しないようにする必要がある。次に、ステップ609において、良好なビンとして定義された全てのビン上で、データを送信する。

【0028】図6のフローは、劣悪なビンに一定のパワー・レベルを維持しないことにより、従来技術の提案に対する改善を与えるものである。加えて、従来技術は、データ・レート上の処理能力を改善するために、よいビンにもマージナル・ビンにも大幅なパワーの増大を許さない。本発明は、パワーの増大を行わなければ、少なくともいくつかのビンにおいて有用なデータを送信および受信できないという点まで信号強度が減衰する場合に、データ・レートを最大に高めることを可能とする。

【0029】図7は、本発明による別の方法を示す。ステップ701ないし704は、図6のステップ601な

いし604と同様であり、これ以上論じないことにする。次に、ステップ706において、マージナル・ビンおよび良好なビンのパワーを増大する。この実施例では、マージナル・ビンのパワーだけを増大するのではない。これによって、良好なビンおよびマージナル・ビンに同様にビット割り当ての増加が可能となる。ステップ720、707、708、709は、図6のステップ620、607、608、609と同様であり、ここではこれ以上論じないことにする。

【0030】図8は、本発明による別の方法を示す。ステップ801ないし804は、図6のステップ601ないし604と同様であり、これ以上論じないことにする。次に、ステップ805において、マージナル・ビンおよび劣悪なビンのパワーを削減する。次に、ステップ806において、良好なビンのパワーのみを増大する。この実施例では、劣悪なビンおよびマージナル・ビンからの使用可能なパワー全てを、良好なビンに割り当てし直す。これによって、良好なビンに割り当てるビットを増加させることができる。通常、特定のBERにおける各ビンの最大データ容量を送信するために必要な量を超えてパワーを増大させることはない。

【0031】本発明を用いたビット・レートの上昇を図9に示す。図9は、使用されていないキャリアに付随するパワーを割り当てし直した場合に、本発明者によって観察されたビット・レート利得を示す。250個のキャリア全てを使用する場合、割り当てし直すパワーはなく、したがって、全体的なデータ・レートの上昇もないことに気が付かれよう。しかしながら、検査したシステムにおいて100個のキャリアのみを用い、150個の使用されていないキャリアからのパワーを使用中のビンに割り当てし直した場合、毎秒約550キロビットのビット・レート上昇が実現した。したがって、ADSLシステムに関連するパワーを割り当てし直すことによって、従来技術の標準に対し、性能の向上が得られること認められよう。本発明を用いると、パワーをビンに割り当てし直すことにより、ビンは追加の距離まで信号を搬送することができるため、信号を送信可能な距離が延長することになる。これは、かかるパワー再割り当てを考慮しない従来技術に対する利点の1つである。

【0032】前述の説明は、ADSLシステムのパワー消費を改善するために好適な方法を明らかにした。本発明について、具体的な実施例を参照しながら説明した。しかしながら、請求項に明記されている本発明の範囲か

ら逸脱することなく、種々の改良や変更も本発明には可能であることを、当業者は認めよう。例えば、前述の具体的な実施例は、図2のSNRref表を用いて、ビンのローディングを判定することについて論じた。ビンのローディングを判定する他の方法も使用可能であることは、当業者であれば認めるであろう。本発明によって予見される改良の一例は、ビンの多数のサブセットを識別し、重み付けすることであろう。本発明は、他のビン分類方法を用いる場合にも等しく適用可能であることを当業者は認めよう。更に他の改良例としては、使用されていないビンのいくつかまたは全てのパワーを周期的に送信し、ビンのSNRを監視することがあげられる。特許請求の範囲においては、ミーンズ・プラス・ファンクション(means-plus-function)項目(群)がある場合は、いずれも、ここに記載した構造で、列挙した機能(群)を行うものを含むこととする。また、ミーンズ・プラス・ファンクション項目(群)は、列挙した機能(群)を行う構造的同等物および同等の構造も含むこととする。

【図面の簡単な説明】

【図1】ADSLシステムを示すブロック図。

【図2】SNR参照表を示す図。

【図3】本発明を実施する具体的な方法を示すフロー・チャート。

【図4】本発明を実施する具体的な方法を示すフロー・チャート。

【図5】本発明を実施する具体的な方法を示すフロー・チャート。

【図6】本発明を実施する具体的な方法を示すフロー・チャート。

【図7】本発明を実施する具体的な方法を示すフロー・チャート。

【図8】本発明を実施する具体的な方法を示すフロー・チャート。

【図9】ビット・レートの上昇対使用キャリア数の関係を示すグラフ。

【符号の説明】

- 10 ADSLシステム
- 15 伝送媒体
- 20 遠隔端末
- 22, 34 システム・コントローラ
- 24, 32 送受信機
- 30 電話局

【図1】

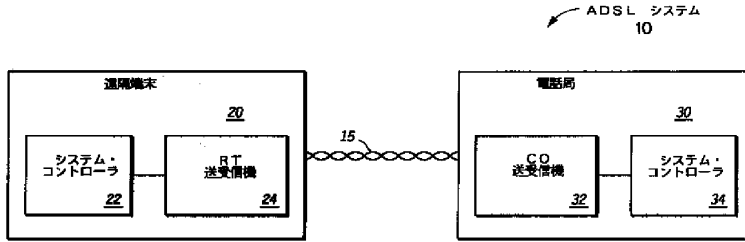

【図2】

SNR表	
ビット	SNR _{REF}
2	14
3	19
4	21
5	24
6	27
7	30
8	33
9	36
10	39
11	42
12	45
13	48
14	51
15	54

【図3】

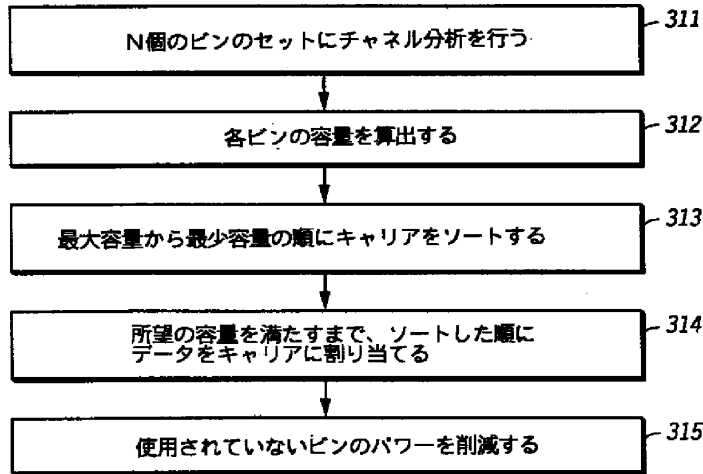

【図9】

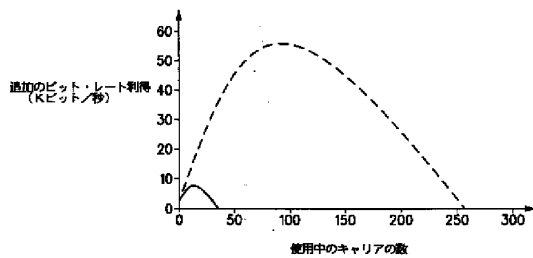

【図4】

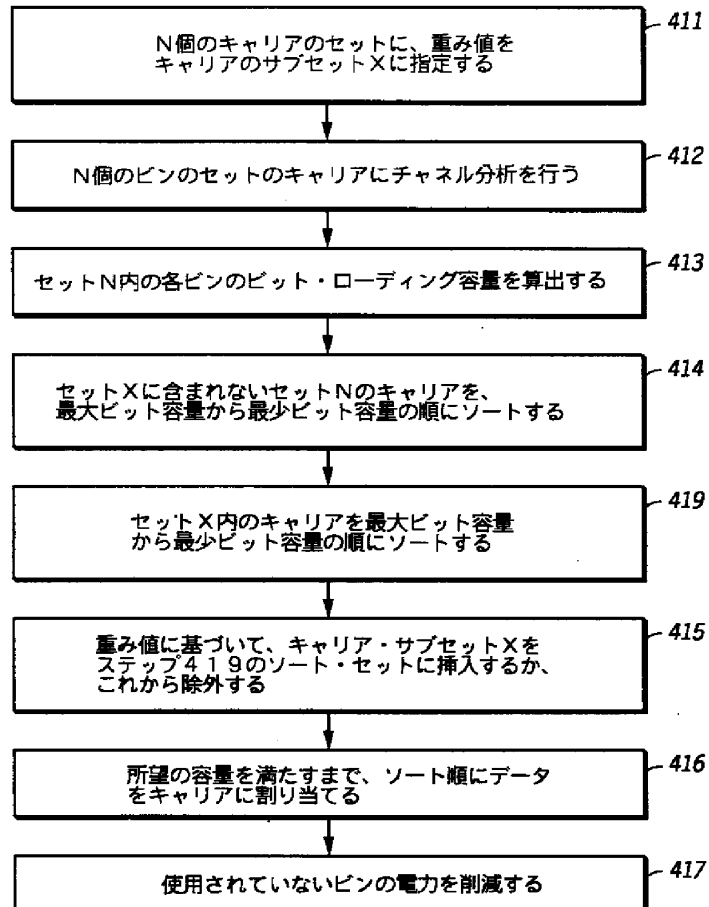

【図5】

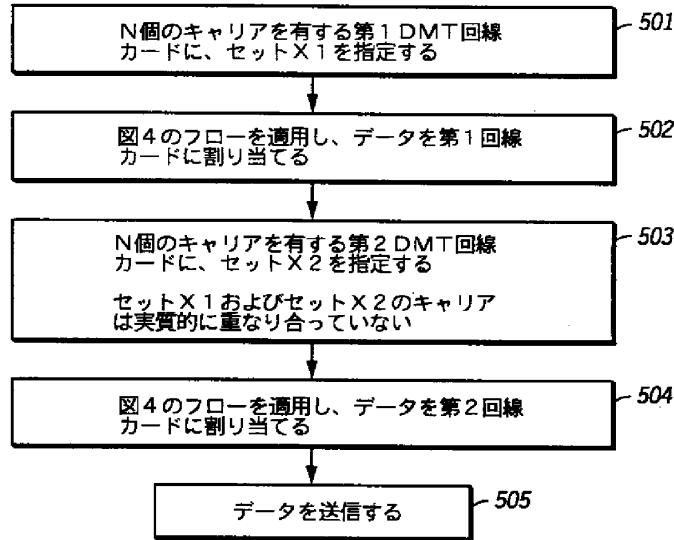

【図8】

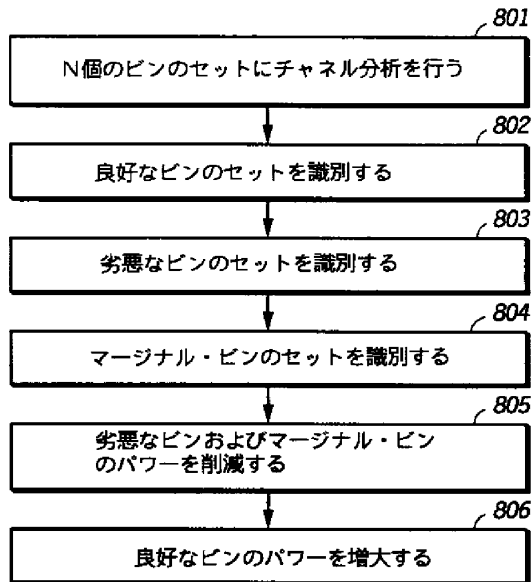

【図6】

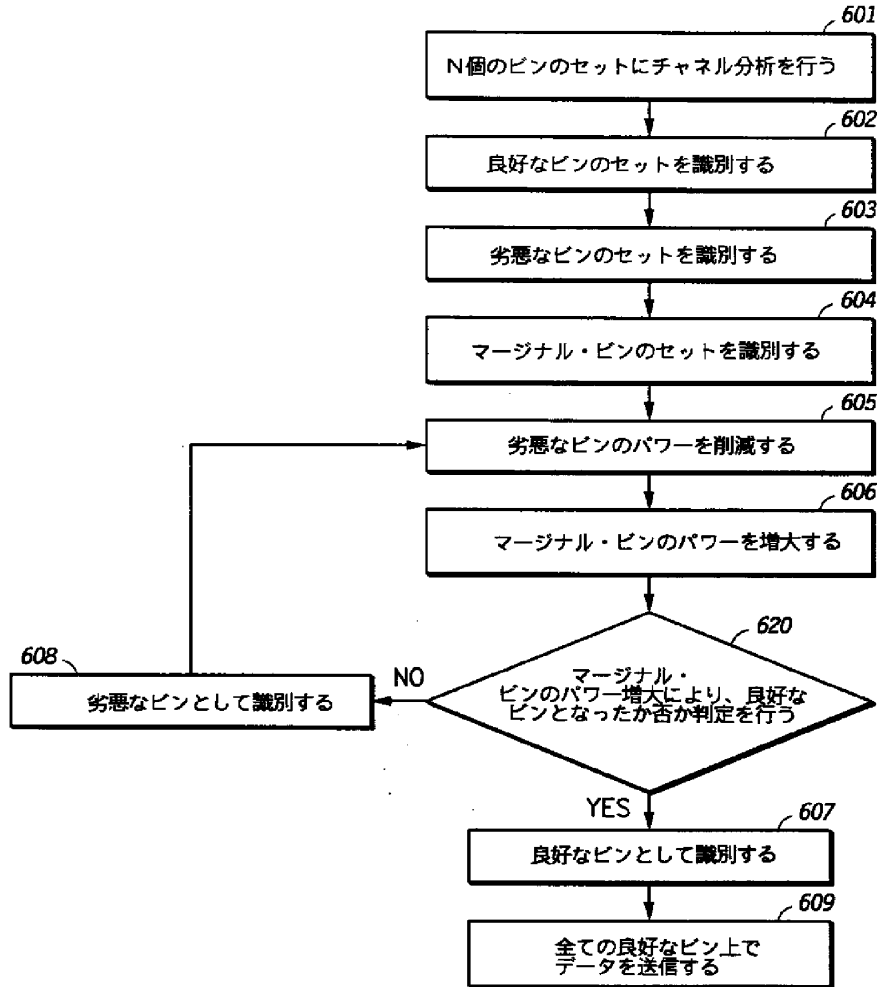

【図7】

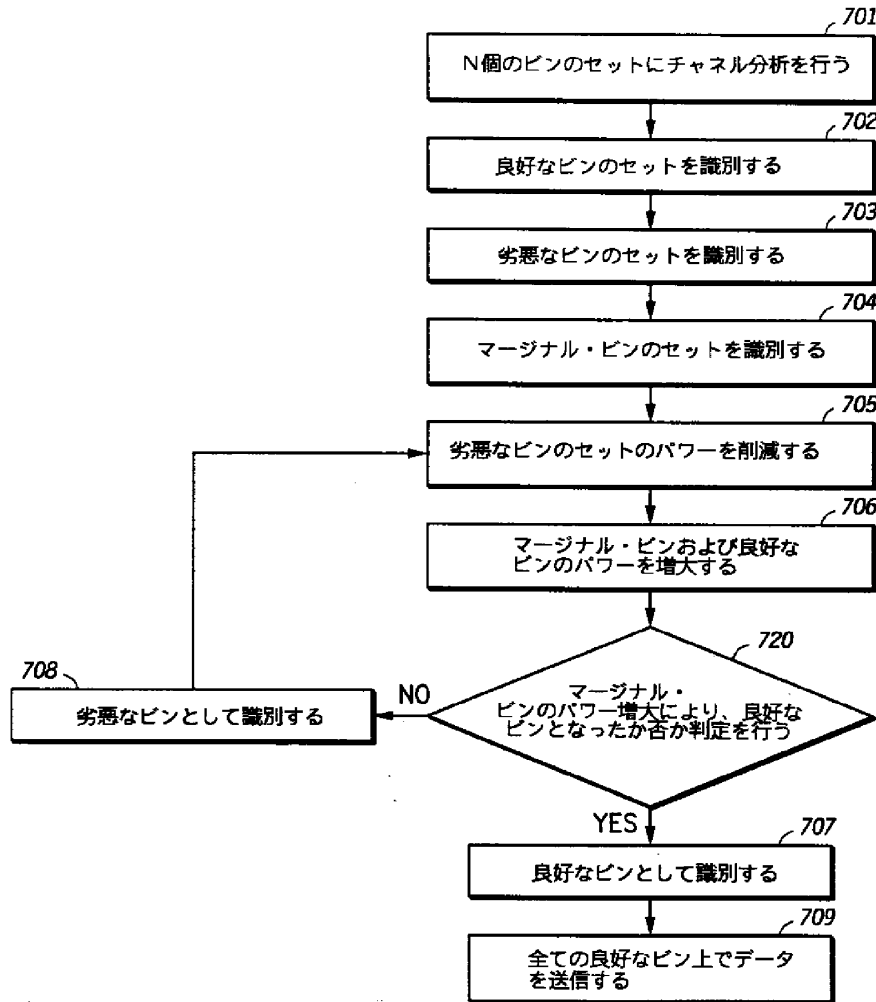

フロントページの続き

(72)発明者 マシュー・エー・ベンドルトン
アメリカ合衆国テキサス州シダー・パーク、
ベイベリー・コート503

(72)発明者 テレンス・ジョンソン
アメリカ合衆国テキサス州オースチン、
チャッカー・サークル10100

ADAPTIVE CHANNEL ALLOCATION IN A FREQUENCY DIVISION MULTIPLEXED SYSTEM

Publication number: JP11508417 (T)

Publication date: 1999-07-21

Inventor(s):

Applicant(s):

Classification:

- international: H04J11/00; H04L5/02; H04L27/26; H04W16/10; H04J11/00; H04L5/02; H04L27/26; H04W16/00; (IPC1-7): H04Q7/36; H04J11/00

- European: H04W16/10; H04L5/00A2A1; H04L5/00C1; H04L5/00C4A; H04Q7/38C4

Application number: JP19960503792T 19960620

Priority number(s): WO1996SE00814 19960620; US19950493489 19950622

Also published as:

WO9701256 (A1)

US5726978 (A)

JP3850878 (B2)

F1974555 (A)

EP0882377 (A1)

more >>

Abstract not available for JP 11508417 (T)

Abstract of corresponding document: WO 9701256 (A1)

A method and system of adaptive channel allocation in a frequency division multiplexed system is provided. In the method and system, a subset of M subcarriers is chosen from a larger set of N subcarriers available for communications on a link. As communications take place on the link, signal quality (C/I) measurements (342) on the subcarriers of the subset of M subcarriers and interference (I) measurements (344) on the subcarriers of the group of N subcarriers are periodically performed. The C/I and I measurements are then used to reconfigure (422) the subset of M subcarriers to reduce co-channel interference on the link.

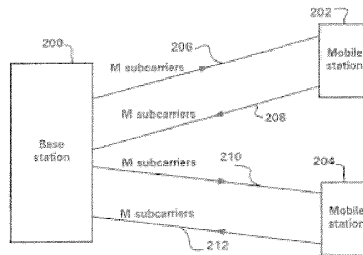

Data supplied from the *espacenet* database — Worldwide

(51) Int.Cl.⁶
H 0 4 Q 7/36
H 0 4 J 11/00

識別記号

F I
H 0 4 B 7/26 1 0 5 D
H 0 4 J 11/00 Z

審査請求 未請求 予備審査請求 有 (全 46 頁)

(21) 出願番号 特願平9-503792
(86) (22) 出願日 平成8年(1996) 6月20日
(85) 翻訳文提出日 平成9年(1997) 12月19日
(86) 国際出願番号 P C T / S E 9 6 / 0 0 8 1 4
(87) 国際公開番号 W O 9 7 / 0 1 2 5 6
(87) 国際公開日 平成9年(1997) 1月9日
(31) 優先権主張番号 0 8 / 4 9 3 , 4 8 9
(32) 優先日 1995年6月22日
(33) 優先権主張国 米国 (U S)

(71) 出願人 テレフオンアクチーボラゲット エル エム エリクソン (パブル)
スウェーデン国 エス-126 25 ストックホルム (番地なし)
(72) 発明者 フロディッヒ, カール マグナス
スウェーデン国 エス-164 43 キスタ, ラングランドスガタン 43, 1トル
(72) 発明者 グドムンドソン, ペロルス レイフ ミカエル
スウェーデン国 エス-164 46 キスタ, コルディングガタン 4, 2トル
(74) 代理人 弁理士 浅村 皓 (外3名)

最終頁に続く

(54) 【発明の名称】 周波数分割多重システムにおけるアダプティブチャネル割当て

(57) 【要約】

周波数分割多重システムにおけるアダプティブチャネル割当て方法およびシステムが提供される。本方法およびシステムでは、リンクの通信に利用可能なN副搬送波の大きなセットからM副搬送波のサブセットが選択される。リンクで通信が行われると、M副搬送波のサブセットの副搬送波の信号品質 (C/I) (342) 測定およびN副搬送波群の副搬送波の干渉 (I) 測定 (344) が周期的に実行される。次に、C/IおよびI測定値を使用してM副搬送波のサブセットが再構成 (422) されリンクの同一チャネル干渉が低減される。

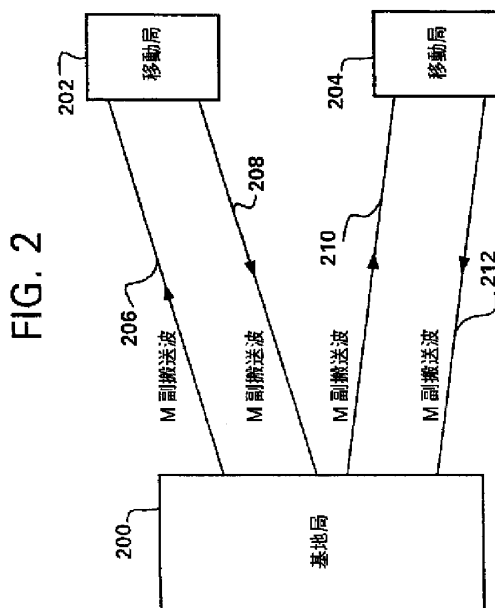

【特許請求の範囲】

1. リンク送信機からリンク受信機への通信がリンクが利用可能な複数の副搬送波のセットのサブセットを介して送信される電気通信システムにおいて、リンクを介した通信の副搬送波割当て方法であって、該方法は、

前記セットから複数の副搬送波を割り当てて前記サブセットを与えるステップと、

前記セットの各副搬送波で受信する信号を測定するステップと、

前記リンクで使用するのに前記サブセットの副搬送波よりも好ましい少なくとも1つの未使用副搬送波が前記セット内に存在するかどうかを確認するステップと、

肯定的確認に回答して前記サブセットを再構成するステップと、

を含む、副搬送波割当て方法。

2. 請求項1記載の方法であって、前記割当てステップは、

前記セットの各副搬送波の干渉レベル(I)を測定するステップと、

前記セットの複数の最低干渉未使用副搬送波を含む前記サブセットを決定するステップと、

を含む、方法。

3. 請求項2記載の方法であって、干渉レベル(I)を測定する前記ステップは、さらに、

前記干渉レベル(I)測定の複数の結果を前記リンク受信機から前記システムへ送信するステップを含み、送信される前記複数の結果の数は前記セット内の副搬送波数よりも少ない方法。

4. 請求項1記載の方法であって、前記測定ステップは、

前記セットの各副搬送波の干渉レベル(I)を測定するステップを含む方法。

5. 請求項1記載の方法であって、前記測定ステップは、

前記サブセットの各副搬送波の信号品質(C/I)を測定するステップを含む方法。

6. 請求項1記載の方法であって、前記測定ステップは、

前記セットの各副搬送波の干渉レベル (I) を測定するステップと、
前記サブセットの各副搬送波の信号品質レベル (C / I) を測定するステップ
と、を含み、

前記確認するステップは、

最低信号品質レベル (C / I) を有する前記サブセットの副搬送波を決定する
ステップと、

前記最低信号品質レベル (C / I) を有する前記サブセットの前記副搬送波
の干渉レベル (I) よりも低い干渉レベル (I) を有する前記セットの未使用副
搬送波が存在するかどうかを確認するステップと、を含む方法。

7. 請求項6記載の方法であって、前記再構成ステップは、

肯定的確認に回答して前記最低信号品質 (C / I) を有する前記副搬送波を前
記サブセットから除去するステップと、

前記未使用副搬送波を前記サブセットへ挿入するステップと、を含む方法。

8. 請求項6記載の方法であって、干渉レベル (I) を測定する前記ステップ
は、さらに、

前記干渉レベル (I) 測定の複数の結果を前記リンク受信機から前記システム
へ送信するステップを含み、送信される前記結果の数は前記セット内の副搬送波
数よりも少なく、

信号品質 (C / I) を測定する前記ステップは、さらに、

前記信号品質 (C / I) 測定の複数の結果を前記リンク受信機から前記シス
テムへ送信するステップを含み、送信される前記結果の数は前記サブセット内の
副搬送波数よりも少ない方法。

9. 請求項1記載の方法であって、前記割当てステップは、

前記セットの各副搬送波の干渉レベル (I) を測定するステップと、

前記セットの複数の最低干渉副搬送波を含む候補サブセットを決定するステッ
プと、

サブセット要求メッセージを前記リンク受信機から前記システムへ送信するス
テップと、

前記システムからの返答メッセージを前記リンク受信機において受信するステ

ップと、

前記候補サブセットが前記リンクに対して受諾されるかどうかを前記返答メッセージから確認するステップと、

を含む、方法。

10. 請求項9記載の方法であって、返答メッセージを受信する前記ステップは、サブセット受諾メッセージを受信するステップを含む、方法。

11. 請求項9記載の方法であって、返答メッセージを受信する前記ステップは、1つ以上の副搬送波拒絶メッセージを含み、前記候補サブセットが受諾されるかどうかを確認する前記ステップは、さらに、

前記サブセットに対する1つ以上の次の候補副搬送波を決定するステップと、

1つ以上の副搬送波要求メッセージを前記リンク受信機から前記システムへ送信するステップと、

完全なサブセットが受諾されるまで、1つ以上の次の候補副搬送波を決定する前記ステップおよび1つ以上の副搬送波要求メッセージを前記システムへ送信するステップを繰り返すステップと、

を含む、方法。

12. 請求項1記載の方法であって、未使用副搬送波が存在するかどうかを確認する前記ステップは、

前記リンクで使用するのに、前記サブセットの副搬送波よりも好ましい前記セットの候補副搬送波が存在するかどうかを確認するステップと、

副搬送波要求メッセージを前記リンク受信機から前記システムへ送信するステップと、

前記システムからの返答を前記リンク受信機において受信するステップと、

前記候補副搬送波が未使用であるかどうかを前記返答から確認するステップと、

前記返答結果から確認を行う前記ステップにおいて肯定的確認がなされるまで、否定的確認に応答して、より好ましい前記セットの副搬送波が存在するかどうかを確認し、副搬送波要求を送信し、返答を受信し、前記返答から確認を行うステップを、毎回異なる候補副搬送波により繰り返すステップと、

を含む、方法。

13. 請求項12記載の方法であって、前記サブセットの各副搬送波で受信する信号を測定する前記ステップは、

前記セットの各副搬送波の干渉レベル(I)を測定するステップと、

前記サブセットの各副搬送波の信号品質レベル(C/I)を測定するステップと、

を含み、

前記リンクで使用するのに、前記サブセットの副搬送波よりも好ましい候補副搬送波が前記セット内に存在するかどうかを確認する前記ステップは、

最低信号品質(C/I)を有する前記サブセットの副搬送波を決定するステップと、

前記最低信号品質(C/I)を有する前記サブセットの前記副搬送波の干渉レベル(I)よりも低い干渉レベル(I)を有する前記セットの候補副搬送波を決定するステップと、

を含む、方法。

14. リンク送信機からリンク受信機への通信がリンクが利用可能な複数の副搬送波のセットのサブセットを介して送信される電気通信ネットワークにおける、リンクを介した通信の副搬送波割当てシステムであって、該システムは、

前記セットから複数の副搬送波を割り当てて前記サブセットを与える手段と、

前記サブセットの各副搬送波で受信する信号を測定する手段と、

前記リンクで使用するのに、前記サブセットの副搬送波よりも好ましい少なくとも1つの未使用副搬送波が前記セット内に存在するかどうかを確認する手段と、

肯定的確認にตอบสนองして前記サブセットを再構成する手段と、

を含む、副搬送波割当てシステム。

15. 請求項14記載の方法であって、前記割当て手段は、

前記セットの各副搬送波の干渉レベル(I)を測定する手段と、

前記セットの複数の最低干渉副搬送波を含む前記サブセットを決定するステッ

ブと、

を含むシステム。

16. 請求項15記載のシステムであって、干渉レベル(I)を測定する前記

手段は、さらに、

前記干渉レベル(I)測定の複数の結果を前記リンク受信機から前記システムへ送信する手段を含み、送信される前記複数の結果の数は前記セット内の副搬送波数よりも少ないシステム。

17. 請求項14記載のシステムであって、前記測定手段は、

前記セットの各副搬送波の干渉レベル(I)を測定する手段を含むシステム。

18. 請求項14記載のシステムであって、前記測定手段は、

前記サブセットの各副搬送波の信号品質(C/I)を測定する手段を含むシステム。

19. 請求項14記載のシステムであって、前記測定手段は、

前記セットの各副搬送波の干渉レベル(I)を測定する手段と、

前記サブセットの各副搬送波の信号品質レベル(C/I)を測定する手段と、

を含み、

前記確認する手段は、

最低信号品質レベル(C/I)を有する前記サブセットの副搬送波を決定する手段と、

前記最低信号品質レベル(C/I)を有する前記サブセットの前記副搬送波の干渉レベル(I)よりも低い干渉レベル(I)を有する前記セットの未使用副搬送波が存在するかどうかを確認する手段と、

を含む方法。

20. 請求項19記載のシステムであって、前記再構成手段は、

肯定的確認に回答して前記最低信号品質(C/I)を有する前記副搬送波を前記サブセットから除去する手段と、

前記未使用副搬送波を前記サブセットへ挿入する手段と、

を含むシステム。

21. 請求項19記載のシステムであって、干渉レベル(I)を測定する前記手段は、さらに、

前記干渉レベル(I)測定の複数の結果を前記リンク受信機から前記システムへ送信する手段を含み、送信される前記結果の数は前記セット内の副搬送波数よ

りも少なく、

信号品質(C/I)を測定する前記手段は、さらに、

前記信号品質(C/I)測定の複数の結果を前記リンク受信機から前記システムへ送信する手段を含み、送信される前記結果の数は前記サブセット内の副搬送波数よりも少ないシステム。

22. 請求項14記載の方法であって、前記割当て手段は、

前記セット各副搬送波の干渉レベル(I)を測定する手段と、

前記セットの複数の最低干渉副搬送波を含む候補サブセットを決定する手段と、

サブセット要求メッセージを前記リンク受信機から前記システムへ送信する手段と、

前記システムからの返答メッセージを前記リンク受信機において受信する手段と、

前記候補サブセットが前記リンクに対して受諾されるかどうかを前記返答メッセージから確認する手段と、

を含む、方法。

23. 請求項22記載のシステムであって、返答メッセージを受信する前記手段は、サブセット受諾メッセージを受信する手段を含む、システム。

24. 請求項22記載のシステムであって、返答メッセージを受信する手段は、1つ以上の副搬送波拒絶メッセージを受信する手段を含み、前記候補サブセットが受諾されるかどうかを確認する前記手段は、

前記サブセットに対する1つ以上の次の候補副搬送波を決定する手段と、

1つ以上の副搬送波要求メッセージを前記リンク受信機から前記システムへ送信する手段と、

完全なサブセットが受諾されるまで、1つ以上の次の候補副搬送波を決定する前記ステップおよび1つ以上の副搬送波要求メッセージを前記システムへ送信するステップを繰り返す手段と、

を含む、システム。

25. 請求項14記載の方法であって、未使用副搬送波が存在するかどうかを確認する前記手段は、

前記リンクで使用するのに、前記サブセットの副搬送波よりも好ましい前記セットの候補副搬送波が存在するかどうかを確認する手段と、

副搬送波要求メッセージを前記リンク受信機から前記システムへ送信する手段と、

前記システムからの返答を前記リンク受信機において受信する手段と、

前記候補副搬送波が未使用であるかどうかを前記返答から確認する手段と、

を含む、方法。

26. 請求項25記載の方法であって、前記サブセットの各副搬送波で受信する信号を測定する前記手段は、

前記セットの各副搬送波の干渉レベル(I)を測定する手段と、

前記サブセットの各副搬送波の信号品質レベル(C/I)を測定する手段と、

を含み、

前記リンクで使用するのに、前記サブセットの副搬送波よりも好ましい候補副搬送波が前記セット内に存在するかどうかを確認する前記手段は、

最低信号品質(C/I)を有する前記サブセットの副搬送波を決定する手段と、

前記最低信号品質(C/I)を有する前記サブセットの前記副搬送波の干渉レベル(I)よりも低い干渉レベル(I)を有する前記セットの候補副搬送波を決定する手段と、

を含む、方法。

【発明の詳細な説明】

周波数分割多重システムにおけるアダプティブチャネル割当て

発明の背景

発明の分野

本発明はセルラー電気通信システムに関し、特に、周波数分割多重システムにおけるアダプティブチャネル割当てに関する。

従来技術の説明

セルラー電気通信システムでは、移動局のユーザはシステムの地理的カバレッジエリアの周りを移動しながら無線インターフェイスを介してシステムと通信する。移動局とシステム間の無線インターフェイスは、各々がシステム内で作動する移動局と無線通信することができる、システムのカバレッジエリアにわたって分散された基地局を設けることにより実施される。典型的なセルラー電気通信システムでは、システムの各基地局はセルと呼ばれるある地理的カバレッジエリア内の通信を制御し、特定のセル内に位置する移動局はそのセルを制御する基地局と通信する。移動局がシステム中を移動すると、システムと移動局間の通信の制御はシステム全体の移動局の移動に従ってセルからセルへ転送される。既存のセルラー電気通信システムは、特定のシステムで作動するようにされた装置のコンパチビリティを保証するさまざまなエアインターフェイス標準(air interface standards)に従って作動する。各標準は全ての動作モードでシステムの移動局と基地局間で行われるプロセスの特定の詳細を提供し、それにはアイドル中、制御チャネル再走査中、登録中、および音声もしくはトラフィックチャネルへ接続中が含まれる。最近のセルラーシステム技術の発展は急速である。これらの技術的発展はセルラーシステムにより提供される次第に複雑化するサービスに対する需要の増大により推進されている。セルラーシステム技術およびセルラーシステムの総数が世界中でこの需要を満たすように増加しているため、それらのシステムを作動させるためのシステム標準数もそれに伴って増加している。

大概の無線システムと同様に、セルラー電気通信システムでは使用できる周波数帯域は限定された資源である。そのため、新しいセルラーシステムを開発する

時は、利用可能な周波数帯域を最も効率的に使用できるようにすることに強調点が集中される場合が多い。さらに、セルラーシステム内での通信はマルチパス伝搬や同一チャネル干渉等のある種のRF信号歪を受ける場合が多い。また、新しいシステム標準の開発ではシステムのセル内の通信に及ぼすこれらのRF信号歪の影響を最小限に抑えることも強調される。

周波数分割多重化(FDM)はセルラーシステムに応用されるデータ通信方法である。直交周波数分割多重化(OFDM)はセルラーシステムに特に適したFDMの特別な方法である。OFDM信号は多重化されたいくつかの副搬送波により構成され、各副搬送波は異なる周波数で連続的ではなく離散的に変動する信号により変調される。変調信号のレベルが個別に変動するため、各副搬送波のパワースペクトルは $(\sin x/x)^2$ 分布に従う。各副搬送波により伝送されるスペクトル形状は、個別の副搬送波のスペクトルが他の副搬送波周波数においてゼロであり副搬送波間に干渉は生じないようにされている。一般的に、NシリアルデータエレメントはN副搬送波周波数を変調し、それは次に周波数分割多重化される。Nシリアルデータエレメントの各々が $T = 1/f_s$ の持続時間のデータブロックを含み、 f_s はOFDM信号の帯域幅である。OFDMシステムの副搬送波は $1/T$ の倍数により周波数が分離される。副搬送波の周波数スペクトルは重畳するが、この周波数間隔により副搬送波は1シンボル期間にわたって直交とされ、変調された各搬送波のパワーのピークは他の搬送波のパワースペクトルのゼロに対応する周波数で生じるようにされる。OFDM信号の全体スペクトルは、OFDM信号に多数のOFDM搬送波が含まれる場合には、矩形に近い。

期間T中に、OFDM信号はNサンプルのブロックで表すことができる。Nサンプルの値は次式で表される。

$$x(n) = \sum_{k=0}^{N-1} X(k) e^{2j\pi nk/N}$$

N値 $X(k)$ はOFDM搬送波 $e^{2j\pi nk/N}$ を変調する離散変動信号の期間T中のデータを表す。前記したことから、OFDM信号はデータサンプル $X(k)$ のセットの離散逆フーリエ変換に対応する。データストリームをOFDM信号へ変換

するために、データストリームは N サンプル $X(k)$ のブロックへ分割され、各ブロックに離散逆フーリエ変換が実行される。時間をかけて特定のサンプル位置に現れるブロックのストリングは、周波数 f_n である副搬送波を変調する離散変動信号を構成する。

OFDMによりセルラーシステムにおいて望ましいいくつかの利点が提供される。OFDMでは、周波数スペクトルにおける副搬送波の直交性によりOFDM信号の全体スペクトルは矩形に近くすることができる。その結果、システムに利用可能な帯域幅が効率的に使用される。OFDMはマルチパス伝搬効果による干渉が低減される利点も提供する。マルチパス伝搬効果は無線波のパスにある建物や他の構造から散乱する無線波により生じる。マルチパス伝搬により周波数選択マルチパスフェージングが生じる。あるOFDMシステムでは、個別の各データエレメントのスペクトルは、通常利用可能な帯域幅の小部分しか占有しない。それにはマルチパスフェージングを多くのシンボルにわたって拡散するという影響がある。それにより周波数選択マルチパスフェージングによるバーストエラーが有効にランダム化され、1つもしくはいくつかのシンボルが完全に破壊されるのではなく、多くのシンボルが僅かに歪むようにされる。さらに、OFDMにより、期間 T は伝送チャネルのシンボル遅延時間に較べて比較的大きく選択できるという利点が提供される。それはさまざまなシンボルの一部を同時に受信することにより生じるシンボル間干渉を低減する効果がある。

セルラーシステムにOFDMを使用することはシミニの論文“Analysis and Simulation of a Digital Mobile Channel Using Orthogonal Frequency Division Multiplexing” IEEE Trans. Commun., Vol. 33, No. 7, pp. 665-675 (1985年7月)に提案されている。OFDMのモバイルシステムへの同様な応用は、キャサの論文“OFDM for Data Communication Over Mobile Radio FM-Channels-Part I: Analysis and Experimental Results”, IEEE Trans. Commun. Vol. 39, No. 5, pp. 783-793 (1991年5月)でも提案されている。これらのOFDMセルラーシステムでは、セル内で作動している基地局から移動局(下り)および移動局から基地局(上り)への伝送のために作り出される各通信リンクに1組の副搬送波周波数が割り当てられる。各通信リンクに割り当てられる副搬送波セットはシス

テムに利用可能な全副搬送波周波数から選択される。セル内では、2つ以上の通信リンクに同じ副搬送波周波数を割り当てることはできない。したがって、同じセル内の副搬送波間で同一チャネル干渉は生じない。しかしながら、このようなOFDMシステムでは、システムのセル内の通信リンクに、システム内の他のセル内に設定された通信リンクにも割り当てられる1つ以上の副搬送波を含む1組の副搬送波が割り当てられることがある。このような共通に割り当てられる各副搬送波周波数は、同じ副搬送波周波数を他のセルで使用することにより生じる同一チャネル干渉を受けることがある。これらのOFDMシステムには、異なるセル内に作り出される通信リンクへの副搬送波周波数の割り当てを調整する方法およびシステムは何も存在しない。このようなシステムでは、近隣セルで使用する副搬送波により生じる通信リンク内の同一チャネル干渉は非常に大きくなることがある。

非OFDMシステム内のセル間でチャネル周波数を割り当てる方法が開発され、それにより同一チャネル干渉は低減されたり最小限に抑えられている。アダプティブチャネル割当て(ACA)はそのような方法である。ACAでは、セルラシステムに割り当てられた任意のチャネル周波数を使用して、ある干渉基準が満たされる限りシステム内のどこかでその周波数が使用されるかどうかに関係なく、システムの任意のセル内でリンクを設定することができる。また、干渉基準が満たされる限り、チャネル周波数はシステム全体を通して自由に再利用することができる。

アダプティブチャネル割当てでは、ダイナミックに割り当てられたチャネル周波数による信号品質および干渉レベルのさまざまな測定はセルのカバレッジエリア内で実行されて、セル内に作り出される通信リンクへ割り当てられるトラフィックもしくは音声チャネルのリストが作られる。セルを制御する基地局およびセルのカバレッジエリア内の移動局は、システム内の通信にダイナミックに割り当てられるようにシステムオペレータが割り当てているチャネル周波数セットにより測定を実行する。一般的には、上りおよび下りの両方の測定が行われる。これらの測定に基づいて、新しいリンクを作り出す時は、あるルールに基づいてリンクにチャネル周波数が割り当てられる。例えば、最小干渉ACAでは、システム

は各セル内で測定される最小干渉（最大品質）チャンネルから最大干渉（最低品質）チャンネルまでのチャンネルのテーブルを作る。次に、システムはそのリストからある数の最小干渉チャンネル周波数を選択してそのセル内での通信へ割り当てる。選択されるチャンネル間の所要の周波数分離およびその周波数により相互変調を生じるようなチャンネルの組合せを回避する等の、他の基準も配慮される。ACAの例として、エッチ・エリクソンの論文“Capacity Improvement by Adaptive Channel Allocation”, IEEE Global Telecomm. Conf., pp.1355-1359, 1988年11月28日-12月1日には、全チャンネルが全ての基地局により共有される共通資源であるセルラー無線システムに関連する容量利得が例示されている。前記した報告書では、移動機は下りの信号品質を測定し、チャンネルは最高搬送波対干渉比（C/Iレベル）を有するチャンネルの選択に基づいて割り当てられる。各リンクに対して1つの搬送波周波数を使用する非OFDMセルラーシステムのために作られている既存のACAアルゴリズムは、OFDMを使用するセルラーシステムでは有効に使用できない。既存のACA技術の1つの問題点は、OFDMシステムにおける副搬送波の数が各通信リンクに対して1つの搬送波を使用するシステムの搬送波の数に較べて大きいことである。それはACAに必要な上りおよび下り測定結果を得るのに時間およびシステム資源の両方を費やす広範な測定努力を必要とする。さらに、移動局で行った多数の下り測定の結果をシステムへ転送して処理するために、大量のシグナリング資源を使用する必要がある。

したがって、OFDMシステムに使用するアダプティブチャンネル割当て方法およびシステムを使用すれば利点を得られる。この方法およびシステムは、システムのセル間の同一チャンネル干渉を低減するようなOFDM内の副搬送波の割り当てを行わなければならない。この方法およびシステムは、また、チャンネル割当て時にシステム資源を有効に利用するためにOFDMシステムのユニークな特徴を考慮するように設計しなければならない。本発明によりこのような方法およびシステムが提供される。

発明の要約

本発明により、直交周波数分割多重（OFDM）システムにおけるアダプティブチャンネル割当て（ACA）方法およびシステムが提供される。この方法および

システムにより、システムのセル間の同一チャネル干渉を緩和するようにOFDMシステムの各リンクへの副搬送波の割当てが行われる。

また、本発明により、非OFDMシステムで使用するよう設計されている従来のACA方法およびシステムをOFDMシステム内で実施する時の困難や欠点が克服される。従来のACA方法は、リンク当たり1チャネルが使用されるシステムへRFチャネルをアダプティブに割り当てるよう設計されている。OFDMシステムに適用する場合、これら従来のACA方法では、ユーザへ割り当てられる全てのOFDM副搬送波をアダプティブに割り当てる必要がある。全てのOFDM副搬送波をOFDMシステムにアダプティブに割り当てるには、システムの送信機と受信機間でチャネル測定情報および割当て情報を転送するために必要な測定およびシグナリング資源があまりにも大量なものとなる。アダプティブに割り当てられる副搬送波を選択し、割当て決定基準を設定することにより、本発明の方法およびシステムでは有効なACAを提供しながら測定およびシグナリング資源の使用を最小限に抑えられる。

本発明の最初の局面において、OFDMシステムの別々の各リンクでの通信に利用可能なN副搬送波の大きな群からM副搬送波の初期サブセットが選択される。数Mは特定リンクのデータレートによって決まり、システムのリンク間で変動することがある。次に、M副搬送波のサブセットはリンクを介して通信を運ぶのに使用される。通信が行われると、M副搬送波のサブセット内の副搬送波の信号品質レベル(C/I)、および利用可能なN副搬送波の全ての干渉レベル(I)が周期的に測定される。これらのC/IおよびI測定結果はシステムへ報告される。リンクを介した通信中に、システムはMのセットの副搬送波よりも良好にリンク上の信号受信を行えるより好ましい未使用副搬送波を、リンクが存在するセル内で利用可能であるかどうかをC/IおよびI測定値から決定する。より好ましい副搬送波が存在すると決定されると、システムは未使用副搬送波を含むようにM副搬送波のサブセットを再構成する。

本発明の第2の局面において、移動局はリンク受信機として、ある選定報告期間に全ての測定結果ではなく測定結果の限定されたセットだけをシステムへ送信する。送信される測定結果の限定されたセットは、最低C/I測定結果の選定番

号および最低 I 測定結果の選定番号を含んでいる。結果の限定されたセットの送信により上りシグナリング資源の使用が低減される。

本発明の別の実施例では、リンク受信機としての移動局は M 副搬送波のサブセット内の副搬送波の信号品質レベル (C/I)、および利用可能な N 副搬送波の全ての干渉レベル (I) を周期的に測定する。次に、移動局は C/I および I 測定値に基づいてリンクの候補置換副搬送波を決定し、副搬送波要求メッセージをシステムへ送信して候補副搬送波を割り当ててリンクの副搬送波を置換するよう要求する。システムは副搬送波受諾もしくは副搬送波拒絶メッセージにより副搬送波要求メッセージに応答する。副搬送波受諾メッセージが受信されると、移動局は候補置換副搬送波を含むように M 副搬送波のサブセットを再構成する。副搬送波が拒絶されると、移動局は新しい候補副搬送波を要求する副搬送波要求メッセージを送信する。

図面の簡単な説明

図 1 は本発明を実施することができるセルラー電気通信ネットワークを示す図

。

図 2 A は本発明に従った直交周波数分割多重システムによる副搬送波の割当てを示す図。

図 3 A は本発明の実施例に従ったシステムのブロック図。

図 3 B および図 3 C は本発明の実施例に従った、それぞれ、リンク送信機およびリンク受信機のブロック図。

図 4 A および図 4 B はリンク受信機により実行される本発明の実施例に従ったプロセスステップのフロー図。

図 5 はセルラー電気通信ネットワーク内で実行される本発明の実施例に従ったプロセスステップのフロー図。

図 6 A および図 6 B はリンク受信機により実行される本発明の別の実施例に従ったプロセスステップのフロー図。

図 7 はセルラー電気通信システム内で実行される本発明の別の実施例に従ったプロセスステップのフロー図。

発明の詳細な説明

図1を参照して、本発明が一般的に関連する周波数分割多重(FDM)セルラ

ー電気通信システムを示す。図1において、任意の地理的エリアは複数の隣接無線カバレッジエリア、すなわちセルC1-C10、へ分割することができる。図1のシステムには10セルしか図示されていないが、セル数は遥かに多くすることができる。

各セルC1-C10内にそれに関連して基地局があり、複数の基地局B1-B10の対応する1つとして示されている。各基地局B1-B10は、従来技術で周知のように、送信機、受信機および基地局コントローラを含んでいる。図1では、基地局B1-B10はそれぞれ各セルC1-C10の中心に配置されており、全指向性アンテナを備えている。しかしながら、別の構成のセルラ無線システムでは、基地局B1-B10は周辺付近、すなわちセルC1-C10の中心から離れて配置することができ、セルC1-C10に全指向性もしくは指向性で無線信号を照射することができる。したがって、図1に示すセルラ無線システムは単なる説明用にすぎず、本発明が実施されるセルラ電気通信システムの考えられる実施例を制限するものではない。

引き続き図1を参照して、セルC1-C10内には複数の移動局M1-M10がある。ここでも、図1には10基の移動局しか図示されていないが、實際上移動局の実際の数はいくらでも常に基地局の数を大きく上回ることをお解り願いたい。さらに、いくつかのセルC1-C10では移動局M1-M10が見つからないが、セルC1-C10の中の任意特定の1つに移動局M1-M10が存在するか否かは、實際上セル内の1つの位置から別の位置へ、もしくは1つのセルから隣接セルや近隣セルへ、さらには特定のMSCが受け持つ1つのセルラ無線システムからこのような別のシステムへローミングすることがある移動局M1-M10のユーザの個別の要望によって決まることをお解り願いたい。

各移動局M1-M10は1つもしくはいくつかの基地局B1-B10および移動局交換局MSCを介して電話呼を開始もしくは受信することができる。移動局交換局MSCは通信リンク、例えば、ケーブルを介して図示する各基地局B1-B10および、図示せぬ、固定公衆交換電話網PSTNもしくは統合システムデ

デジタルネットワーク（ISDN）施設を含むことができる同様な固定網に接続することができる。移動局交換局MSCと基地局B1-B10間、もしくは移動局

交換局MSCとPSTNもしくはISDN間の関連する接続は図1に完全には図示されていないが当業者ならば周知である。さらに、セルラー無線システムに2つ以上の移動局交換局を含め、各付加移動局交換局をケーブルや無線リンクを介して異なる基地局群および他の移動局交換局に接続することも知られている。

各MSCはシステム内で各基地局B1-B10およびそれと通信する移動局M1-M10間の通信の管理を制御することができる。移動局がシステムの周りをローミングすると、移動局はそれが位置するエリアを制御する基地局を介してその位置をシステムに登録する。移動局電気通信システムが特定の移動局へアドレスされた呼を受信すると、その移動局へアドレスされたページングメッセージが、移動局が位置すると思われるエリアを制御する基地局の制御チャネルを介して同報される。そこへアドレスされたページングメッセージを受信すると、移動局はシステムアクセスチャネルを走査して最強アクセスチャネル信号を受信した基地局へページ応答を送る。次に、呼接続を生じるプロセスが開始される。MSCは、通信の進行中にセルからセルハシステム中を移動する移動局に回答して移動局との通信を1つの基地局から別の基地局へ切替えを制御するだけでなく、その基地局B1-B10が受け持つ地理的エリアにいると思われる移動局のその移動局に対する呼の受信に回答したページング、移動局からページ応答を受信した時の基地局による移動局への無線チャネルの割当て、を制御する。

各セルC1-C10に複数のFDM副搬送波および少なくとも1つの専用制御チャネルが割り当てられる。制御チャネルはこれらのユニットに対して送受信される情報により移動局の動作を制御もしくは管理するのに使用される。このような情報には着信呼信号、発信呼信号、ページ信号、ページ応答信号、位置登録信号および音声およびトラフィック副搬送波割当てを含むことができる。

本発明には、図1に示すようにアダプティブチャネル割当（ACA）方法およびシステムをFDMセルラーシステムに実施することが含まれる。本発明の代表的な実施例では、5MHzの総システム帯域幅および5kHzの副搬送波で作動

するOFDMシステムにACAが実施される。このシステムに利用可能な総副搬送波数はおよそ $5\text{MHz} / 5\text{kHz} = 1000$ となる。副搬送波は 2GHz の周波数でシステムRF搬送波へ変調されてシステムRFチャネルを介して伝送され、

送信信号の周波数スペクトルはRF搬送波を中心としている。全ての搬送波を各セル内で使用することができるが、副搬送波はセル内の2つ以上のリンクで同時に使用することはできない。周波数分割二重化(FDD)が上りおよび下り副搬送波の分離に使用される。本システムは、切替制御情報、長期チャネル割当情報、長期電力制御情報および測定メッセージおよび測定結果を伝送する上りおよび下りの両チャネルである専用制御チャネル(DCCH)を含んでいる。本システムは、また、短期チャネル割当情報、短期電力制御情報、測定メッセージおよび測定結果を伝送する上りおよび下りの両チャネルである物理的制御チャネル(PCCH)も含んでいる。

本発明のACAでは、移動局と基地局間の各上り/下りリンクに対して、システムはいくつか(N)の副搬送波のセットからいくつか(M)の副搬送波のサブセットを選択する。N副搬送波のセットは各リンクに対してシステム内で利用可能な副搬送波のセットであり、 $N > M$ である。N副搬送波のセットは通信中は変動しない。N副搬送波のセットはシステムの全副搬送波を含むことができる。また、N副搬送波のセットは利用可能な副搬送波の総数よりは少ないがM副搬送波のサブセット内の搬送波数よりも多いセットとすることができる。

次に、図2を参照して、OFDMシステムにおける本発明に従った副搬送波の割当てを示す。基地局200は下りリンク206および上りリンク208を介して移動局202と通信する。基地局200は下りリンク210および上りリンク212を介して移動局204とも通信する。リンク206, 208, 210および212を介した伝送はシステムRFチャネルにより行われる。各リンクを介して伝送される音声およびデータはいくつか(M)の副搬送波により変調される。次に、M副搬送波はシステムRFチャネルにより変調されてシステムRFチャネルにより伝送される。セル内の各リンク206, 208, 210および212は

M副搬送波の別々のサブセットを使用する。副搬送波はセル内で1回しか使用できない。

次に、図3Aを参照して、本発明に従ったシステムのブロック図を示す。本システムはリンク送信機300、リンク受信機330、ACA処理部360およびRFチャネル380により構成される。特定リンクの受信機330および送信機

300はリンクの両端に配置されている。下りリンクでは、受信機330は移動局内に配置され送信機300は基地局内に配置されている。上りリンクでは、受信機330は基地局内に配置され送信機300は移動局内に配置されている。RFチャネルは利用可能なN副搬送波のセットを有している。リンク受信機330およびリンク送信機は、利用可能なM副搬送波のサブセットを使用してRFチャネル380により通信する。

次に、図3Bおよび図3Cを参照して、図3Aのそれぞれ送信機300および受信機330の機能ブロック図を示す。図3Bおよび図3Cに示す機能的特徴は基地局および移動局の両方の受信機および送信機に共通である。

送信機300はシリアル/パラレルコンバータ302、マッピング回路(MAP)304、逆高速フーリエ変換(IFFT)回路306、周波数マルチプレクサ(MUX)308、および変調器310を含んでいる。送信機の動作において、シリアル/パラレルコンバータ302はシリアルデジタルデータストリーム312をMシンボルのブロック314へ変換し、Mはシンボルサイズおよびシステムのデータレートにより決定される。次に、MシンボルはMAP回路304へ入力され、Mシンボルの各々がIFFT回路306の副搬送波入力へマップされる。次に、IFFT回路306へ入力されるデータブロックに逆高速フーリエ変換(IFFT)が実行される。次に、IFFT回路306のN出力に発生される信号318がMUX308において多重化されて、各々がMシンボル314の中の1つのシンボルを含むデータを運ぶ、多重化されたM副搬送波を含む信号320が作り出される。次に、信号320は変調器310においてシステムRF搬送波324上へ変調され、OFDM信号としてシステムRFチャネル322により伝送される。

受信機330は復調器332、周波数デマルチプレクサ(DEMUX)334、高速フーリエ変換回路336、デマッピング回路(DEMAP)338、パラレル/シリアルコンバータ340、干渉測定手段344、信号品質測定手段342およびプロセッサ346を含んでいる。受信機の動作において、システムRF搬送波がシステムRFチャネル322により受信され次に復調器332において復調され、DEMUX334においてデマルチプレクされて、多重化されたM副搬

送波を含む信号のNサンプル348が得られる。次に、Nサンプル348を入力として、FFT回路336により高速フーリエ変換(FFT)が実行され、各副搬送波により伝送された任意の変調データを含むデータ信号350を発生する。復調されFFTされるN副搬送波はプロセッサ346からDEMUX334およびFFT回路336へ入力されるパラメータにより決定される。干渉測定手段344はNサンプル348の各々から回復される各データ信号350の干渉(I)レベルを測定する。次に、N受信データ信号350がデマッピングブロック338へ入力され、現在リンク通信に割り当てられているM副搬送波周波数Nデータ信号350からデマップされる。デマッピングはプロセッサ346からDEMAPブロック338へ入力されるパラメータに従って行われる。次に、デマップされたMデータ信号352がパラレル/シリアルコンバータ340へ入力されてシリアル受信データ354へ変換される。受信機330が受信しているリンクに現在割り当てられているM副搬送波周波数により受信されるデマップされたMデータ信号352の各々について、デマッピングブロック338の出力において信号品質(C/I)が測定される。

各リンクに対するアダプティブチャネル割当ては、リンク受信機内で実行される測定の結果を演算する図3AのACA処理部360により実行される。図示する実施例では、プロセッサ346は干渉測定手段344からの干渉測定値および信号品質測定手段342からの信号品質測定結果を受信する。プロセッサ346は測定結果を演算してシステムのACA処理部360へ入力するデータを発生する。次に、プロセッサ346から発生されたデータはインターフェイス362を

介して A C A 処理部 3 6 0 へ転送される。図示する実施例では、A C A 処理部 3 6 0 は M S C 内に配置されている。A C A 処理部 3 6 0 はシステムの基地局内に配置することもできる。A C A 処理部により実行される機能を移動局、基地局および M S C 間に分散することも考えられる。必要なデータを格納するメモリの構成方法、およびこの種の機能を実行するマイクロプロセッサおよびソフトウェアの構成方法は当業者ならば周知である。

移動局がリンク受信機として機能する場合には、プロセッサ 3 4 6 は A C A データを移動局送信機へ転送し、適切な制御チャネルの上りリンクを含むインター

フェイス 3 6 2 を介してシステムへ伝送する。リンク受信機としての基地局において、プロセッサ 3 4 6 はランドラインおよび他の接続を含むインターフェイス 3 6 2 を介して M S C へ A C A データを転送する。A C A 処理部 3 6 0 はデータを演算し、基地局がリンク受信機である場合にはランドラインもしくは他の接続を含み、移動局がリンク受信機である場合には適切な制御チャネルの下りリンクを含む、インターフェイス 3 6 4 を介してリンク受信機 3 3 0 へ適切な副搬送波割当てコマンドを戻す。リンク受信機 3 3 0 のプロセッサ 3 4 6 はコマンドを受信し、次に、リンクに正しい副搬送波が受信されるように受信機に正しい入力パラメータを発生する。また、A C A 処理部 3 6 0 はインターフェイス 3 6 6 を介してリンク送信機 3 0 0 に関連する M A P 回路 3 0 4 へコマンドを送る。次に、M A P 回路 3 0 4 は M シンボルを M A P 回路 3 0 4 の適切な出力へマップして、M 副搬送波の正しいサブセットが伝送されるようにする。

移動局、基地局およびシステムの M S C 間の必要なデータ転送は周知の方法により達成することができる。ここに記載する実施例では、D C C H および P C C H チャネルを上りおよび下りの両方で使用して、移動局とシステムの間で測定結果や副搬送波割当てメッセージを転送することができる。

次に、図 4 A を参照して、A C A プロセス中にリンク受信機 3 3 0 により実行されるステップを示すフロー図を示す。下りリンクで受信する移動局により実行されるステップおよび上りリンクで受信する基地局により実行されるステップは本質的に同じであり、図 4 A は両方の場合にリンク受信機 3 3 0 により実行され

るステップを説明するのに使用することができる。移動局および基地局で実行されるプロセスステップの違いは図4Aのステップ428である。図4BはACA測定プロセスのステップ428中に移動局により実行される付加ステップを示すフロー図である。これらの特別なステップは、図4Aのプロセスを説明する時に図4Bを参照して説明される。

ACAプロセスは、上りリンクもしくは下りリンクのいずれかにより一対の移動局および基地局間にシステムが通信リンクを作り出す必要がある時に開始される。再び図4Aを参照して、ステップ402においてリンク受信機はシステムから測定順メッセージを受信して、リンクに利用可能な一群のN副搬送波の各々の

干渉(I)を測定する。N副搬送波はシステム内で利用可能な全ての副搬送波もしくはシステム内で利用可能な全ての副搬送波から選択される小さな一群の副搬送波とすることができる。次に、ステップ404において、Iが実行される。次に、ステップ404からプロセスはステップ406へ移り、そこでI測定結果がシステムへ送られる。移動局がリンク受信機であれば、I測定結果はDCC HもしくはPCC Hチャンネルを介して基地局へ送信され、次に、MSCへ転送される。基地局がリンク受信機であれば、I測定結果は適切なオーバーランド手段を介してMSCへ転送される。I測定結果を送信した後で、プロセスはステップ408へ移り、そこでリンク受信機はシステムからの応答を待つ。次に、図5を参照して、リンク受信機がステップ408において待機状態である時にとられるステップについて説明する。

図5を参照して、ACAプロセス中にシステムのACA処理部内で実行されるプロセスステップを示す。ステップ502において、リンク受信機がN副搬送波により実行するI測定の結果がACAプロセッサにより受信される。次に、ステップ504において、ACAプロセッサはN副搬送波によるI測定の結果から最小干渉未使用M副搬送波を決定する。ステップ505からプロセスはステップ506へ移り、そこで、最小干渉M副搬送波のサブセットをリンクへ割り当てる副搬送波割当てメッセージがリンク受信機およびリンク送信機の両方へ送られる。ここで、ACAプロセッサはステップ508へ移り、リンク受信機からの入力を

さらに待機する。次に、プロセスフローは図4Aのステップ408へ戻る。副搬送波割当てメッセージのM副搬送波を決定する別の方法をステップ506の替わりに使用することができる。例えば、副搬送波は、それらの使用が近隣セルの送信にどのような影響を及ぼすかに基づいて割り当てることができた。最小干渉M副搬送波の1つが近隣セルで使用される場合には、副搬送波は使用されないことがある。この場合、M副搬送波は最小干渉M副搬送波ではないことがある。

再び図4Aを参照して、408において待機状態であるリンク受信機はステップ410へ移り、M副搬送波のサブセットをリンクへ割り当てるチャンネル割り当てメッセージを受信する。次に、リンク受信機がM副搬送波の割り当てられたサブセットを使用するリンクによる受信を開始すると、プロセスはステップ412へ移る。次に、ステップ412からプロセスはステップ414へ移り入力をさらに待機する。ステップ416において、入力を受信される。リンク受信機は、M副搬送波の割り当てられたサブセットを使用して受信しながら、3種の入力を受信することができる。判断ステップ418において、リンク受信機は呼終了信号を受信されているかどうかを確認する。呼終了信号を受信されておれば、プロセスは終わる。呼終了信号はシステムによりリンク受信機へ送信されていたり、リンク受信機自体において開始されていることがある。呼終了信号はリンクを介した通信が終了していることをプロセスに示す。呼終了信号を受信されていなければ、プロセスはステップ420へ移り、リンク受信機は測定タイマメッセージを受信されているかどうかを確認する。測定タイマはリンク受信機に関連するプロセス内に含まれている。測定タイマは周期的間隔で測定メッセージを発生してリンク受信機に測定を行うよう知らせる。各測定タイマ信号により測定間隔が規定される。測定タイマメッセージを受信されておれば、プロセスはステップ424へ移る。ステップ424において、リンク受信機はN副搬送波のセットについてIを測定する。I測定値は各副搬送波に対するある数の前のI測定値の結果を平均化して精度を得ることができる。最初にステップ424を通る時に、測定値はステップ404で得られる結果で平均化される。その後ステップ424を通る時は、測定結果は前の最後のn測定値により平均化され、nはシステム内で副

搬送波の干渉レベルを正確に追従できる値である。ステップ424からプロセスはステップ426へ移り、リンク受信機はM搬送波のサブセットの各々についてC/Iを測定する。C/I測定値も前の最後のnのC/I測定値により平均化される。次に、ステップ428において、リンク受信機はIおよびC/I測定結果をシステムのACA処理部へ送る。リンク受信機が基地局であるか移動局であるかに応じて、ステップ428は異なる方法で実行することができる。リンク受信機が基地局であれば、平均化された測定結果がACAプロセッサへ直送される。リンク受信機が下りリンク内の移動局であれば、図4Bに示すサブステップを使用して、結果が基地局を介して上りリンクによりシステムへ送信される時のシグナリングトラフィックを低減することができる。

次に、図4Bを参照して、図4Aのステップ428を実行する移動局により実行されるプロセスサブステップを示す。上りリンクのシグナリングトラフィックは、測定結果の異なるセットを異なる時間間隔にわたってシステムへ送信することにより低減される。長い報告期間にわたって、全てのI測定値およびC/I測定結果がシステムへ送信される。より短い報告期間にわたって、I測定値およびC/I測定結果の各々の低減されたセットが送信される。長いおよび短い期間は、第n番の短い期間毎にもしくは第n番の測定期間毎に長い期間が生じるように規定することができる。nは例えば25等の数である。ステップ428aにおいて、移動局は測定期間に測定結果を報告する短い時間間隔が含まれているどうかを確認する。測定期間に測定結果を報告する短い時間間隔が含まれていることが確認されれば、プロセスはステップ428bへ移り、そこで移動局はM副搬送波のサブセットのYの最悪品質副搬送波に対するC/I測定値、 $Y < M$ 、およびN副搬送波のZの最小干渉に対するI測定値、 $Z < N$ 、をシステムへ送信する。YおよびZの値は、シグナリングトラフィックを最小限に抑えながら有効なACAに対する適切な情報を与えるように選択される。Yは1に設定することができ、Zは同じセル内で使用されない少なくとも1つの副搬送波のI測定結果を平均として含む計算された数に設定することができる。次に、プロセスはステップ414へ移り、そこで移動局はさらに入力を待機する。しかしながら、ステップ428

aにおいて、測定期間に測定結果を報告するための短い時間間隔が含まれないことが確認されると、プロセスはステップ428cへ移る。ステップ428cにおいて、移動局はM副搬送波の全サブセットに対するC/I測定値および全N副搬送波に対するI測定値をシステムへ送る。次に、プロセスはステップ414へ移り、そこで移動局はさらに入力を待機する。次に、ACAプロセッサがリンク受信機から測定結果を受信するとプロセスフローは図5へ移る。

再び、図5を参照して、ステップ508において待機状態にあるACAプロセッサは、ステップ510においてリンク受信機からの入力を受信する。ステップ510において、ACAプロセッサは測定結果もしくは呼終了信号を受信することができる。入力が受信されると、プロセッサはステップ512へ移り、そこでどのタイプの入力が受信されたかが確認される。セル終了信号が受信されると、プロセスが終わる。この例では、受信メッセージは測定結果であるためプロセス

はステップ514へ移る。ステップ514において、ACAプロセッサはMのサブセットの副搬送波が最低C/I測定値を有する副搬送波を使用したかどうかを確認する。次に、ステップ516において、M副搬送波のサブセットの最低C/I測定値がACA C/Iトリガしきい値よりも低いかどうかを確認される。ステップ516において、最低C/I測定値がACA C/Iトリガしきい値よりも低くないことが確認されれば、プロセスフローはステップ508へ戻りそこでACAプロセッサはさらに入力を待機する。しかしながら、ステップ516において、最低C/I測定値がACA C/Iトリガしきい値よりも低いことが確認されれば、プロセスフローはステップ518へ移る。ステップ518において、ACAプロセッサは最低C/I測定値を有するMのサブセットの副搬送波のI測定値よりも小さいI測定値を有するN副搬送波のセットの未使用副搬送波が存在するかどうかを確認する。ステップ518において、小さいI測定値を有する未使用副搬送波が存在しないことが確認されれば、プロセスフローはステップ508へ戻りそこでACAプロセッサはさらに入力を待機する。しかしながら、ステップ518において小さいI測定値を有する未使用副搬送波が存在すれば、より好ましい副搬送波が存在し、プロセスはステップ520へ移る。ステップ520

において、ACAプロセッサは最小干渉未使用副搬送波をM副搬送波のサブセットへ挿入して、最低C/I測定値を有するMのサブセットの副搬送波をサブセットから除去する。ヒステリシス効果を回避するために、ステップ518中に最小干渉未使用副搬送波に対するC/Iを算出した後で副搬送波の変化を行って、算出したC/Iが除去すべき副搬送波のC/Iよりも最少量上回ることを確認することができる。最小干渉未使用副搬送波に対するC/Iが除去すべき副搬送波のC/Iを最少量上回らない場合には、未使用副搬送波は置換副搬送波として受諾できないと見なされる。ステップ520から、プロセスはステップ522へ移り、そこでシステムは再構成サブセットメッセージをリンク受信機へ送り、リンクに割り当てられたM副搬送波のサブセットを再構成してプロセッサが行う変化に従わせるようリンク受信機を命令する。次に、ACAプロセッサはステップ508へ移り、さらにリンク受信機からの入力を待機する。複数のより干渉の少ない未使用副搬送波を決定しそれらをC/Iしきい値よりも干渉の少ない複数の未使用

副搬送波と交換することにより、ステップ514-520による手順を交互に実行することができる。サブセットは他の基準に従って再構成することもできる。例えば、リンクのセル内で、サブセットを使用することが近隣セル内で生じる通信へ及ぼす影響に基づいてMのサブセットを再構成することができる。セル内で使用されるいくつかのM副搬送波が近隣セルでも使用される場合には、それらは近隣セルでも使用されないセル内で未使用の副搬送波と置換することができる。使用する副搬送波がC/Iしきい値よりも小さくなかったり、未使用副搬送波の干渉レベルが置換した副搬送波よりも大きい場合でも、再構成を行うことができる。

呼が進行しリンクを介した通信が継続する限り、プロセスは継続する。次に、リンク受信機は入力を受信するとステップ408の待機状態から移り、呼が終了するまで図4A、図4Bおよび図5に示すプロセスステップが繰り返され、呼終了信号がリンク送信機、リンク受信機およびシステムのACA処理部により受信される。

本発明の別の実施例では、リンク受信機としての移動局は、リンク上で使用される、M副搬送波のあるサブセットを要求する、もしくはM副搬送波と置換する副搬送波を要求する要求メッセージを送信する。信号測定結果は移動局からシステムへ送信する必要がない。次に、システムはサブセット受諾もしくは副搬送波受諾メッセージを移動局へ送信する。下りリンクACA処理は主として移動局内の受信機のプロセッサ346内で行われる。この実施例では、最初の実施例のシステムにより実行される、図5に示すステップ504、514、516、518および520は移動局内のプロセッサ346により実行される。上りリンク測定のための基地局ACAプロセスフローは図4A、図4Bおよび図5に示すものと変わらない。

次に、図6Aを参照して、本発明の別の実施例のACAプロセス中にリンク受信機としての移動局により実行されるステップを示すフロー図を示す。ACAプロセスは移動局がステップ602において測定順メッセージを受信する時に開始される。次に、ステップ604において、リンクにとって利用可能なN副搬送波群の各々について干渉(I)が移動局で測定される。次に、プロセスはステップ606へ移り、そこで最少干渉M副搬送波が決定される。ステップ606から、プロセスはステップ608へ移り、サブセット要求メッセージが移動局によりシステムへ送られる。サブセット要求メッセージは、移動局が要求したサブセット内の各副搬送波の使用を要求することをシステムへ示す。次に、プロセスはステップ610へ移り、移動局はシステムからの返答を待機する。次に、図7を参照して、プロセスがステップ610において待機状態である時にとられるプロセスステップについて説明する。

図7を参照して、ACAプロセスに移動局が含まれる場合に本発明の別の実施例に従ったシステムのACA処理部内で実行されるプロセスステップを示す。ステップ702において、ACA処理部はサブセット要求メッセージを受信する。次に、ステップ704において、システムは移動機が要求したサブセット内のM副搬送波の全てを使用できるかどうかを確認する。例えば、他の移動局が使用中であったり、特殊用途のためにシステム内に保存されている場合、ある副搬送波

はセル内で利用できないことがある。M副搬送波の可用性はその使用が近隣セルの通信に及ぼす影響として決定することもできる。ACAはシステムオペレータがこれらの判断を行う際に柔軟性を与えるように設計される。移動局が要求したサブセット内のM副搬送波を全て使用できることが確認されれば、システムはサブセット受諾メッセージをリンク受信機へ送信する。しかしながら、ステップ704において、提示されるサブセットの副搬送波は移動局により使用されないことが確認されると、プロセスはステップ720へ移りシステムは利用不能な副搬送波を拒絶する副搬送波拒絶メッセージをM副搬送波のサブセットの一部として送信する。次に、プロセスフローはステップ722へ移り移動局からの返答を待機する。

次に、図6Aを参照して、ステップ612において、移動局はシステムから送信されるサブセット受諾メッセージもしくは副搬送波拒絶メッセージを受信する。サブセット受諾メッセージを受信されると、プロセスはステップ620へ移りそこでリンク受信機は割り当てられたサブセットを使用して受信を開始する。しかしながら、ステップ614において、副搬送波拒絶メッセージを受信されていることが確認されると、プロセスはステップ616へ移る。ステップ616にお

いて、リンク受信機は拒絶された要求副搬送波と置換する次の候補を決定する。これらの候補はMの提示されたセット内には無い利用可能なN副搬送波のセットの次に干渉の少ない副搬送波である。

ステップ616から、プロセスはステップ618へ移りそこで次の候補副搬送波を要求する副搬送波要求メッセージがシステムへ送信される。次に、プロセスはステップ610へ移りリンク受信機は返答を待つ。M副搬送波の完全なサブセットが受諾されるまで、プロセスはステップ610, 612, 614, 616, 618, および706, 708により形成されるループを継続する。次に、プロセスはステップ620へ移り、そこで移動局は受諾されたサブセットを使用してリンクを介した受信を開始する。次に、プロセスはステップ622の待機状態へ移る。ステップ622の待機状態において、プロセスは呼終了もしくは測定タイ

マメッセージを受信することができる。呼終了および測定タイムメッセージは本発明の前記実施例について説明した呼終了および測定メッセージと同等である。リンク受信機はステップ624において呼終了もしくは測定タイムメッセージを受信してステップ626へ移り、そこで呼終了が受信されているかどうかを確認される。呼終了が受信されておれば、プロセスは終了する。しかしながら、測定タイムメッセージが受信されておれば、プロセスはステップ628へ移る。ステップ628において、移動局は利用可能なN副搬送波の全てについてIを測定し、各副搬送波について結果を平均化する。次に、ステップ630において、リンク受信機はM副搬送波のサブセットについてC/Iを測定し、各副搬送波について結果を平均化する。次に、プロセスは図6Bのステップ632へ移る。

ステップ632において、リンク受信機は最低C/Iを有するMのサブセットの副搬送波を決定する。次に、ステップ634において、最低C/Iがしきい値よりも小さいかどうかを確認される。しきい値よりも小さくなければ、プロセスはステップ622へ戻りそこでリンク受信機は別の呼終了もしくは測定タイムメッセージを待機する。しかしながら、最低C/Iがしきい値C/Iよりも小さいことが確認されると、プロセスはステップ636へ移る。ステップ636において、Nのセットのより干渉の少ない副搬送波がMのセット内に存在しないかどうかを確認される。より干渉の少ない副搬送波が存在しなければ、プロセスはステ

ップ622へ戻る。しかしながら、より干渉の少ない副搬送波が存在すれば、より好ましい副搬送波が存在しプロセスはステップ638へ移る。ステップ638において、移動局は副搬送波要求メッセージをシステムへ送信して、M副搬送波のサブセット内に無い最少干渉副搬送波を最低C/I副搬送波に置換する副搬送波として要求する。次に、移動局内のプロセスはステップ640の待機状態へ移りプロセスフローは図7のステップ708へ移る。システムのACA処理部はステップ710において要求した副搬送波メッセージを受信する。ステップ632-638で略述した手順は、サブセットの最低C/Iを有する複数の使用副搬送波を決定し、次に複数のより干渉の少ない未使用副搬送波を要求した置換副搬送波と決定して実行することもできる。副搬送波要求メッセージの受信後、ステ

プ716において、要求した副搬送波が別の移動局のあるリンクを介してセル内で使用されるかどうかを確認される。要求した副搬送波がセル内で使用される場合、システムはステップ718へ移って要求した副搬送波拒絶メッセージを移動局へ送信し、プロセスはステップ708へ戻る。しかしながら、提示された置換副搬送波がセル内で使用されない場合には、システムは要求した副搬送波受諾メッセージを移動局へ送信し、プロセスはステップ708へ戻る。要求した副搬送波がセルにより使用されるかどうかを確認する代わりに、他の基準を使用して可用性を決定することができる。例えば、要求した副搬送波が近隣セル内で使用される場合には、システムは副搬送波要求を拒絶することができる。次に、プロセスはステップ640の待機状態からステップ642へ移り、移動局は受諾もしくは拒絶メッセージを受信する。次に、ステップ644において、要求した副搬送波が受諾されたかどうかを確認される。要求した副搬送波が受諾されておれば、プロセスはステップ646へ移り移動局はそれを介して受信しているM副搬送波のサブセットを、要求した副搬送波を含み最低C/I副搬送波を削除するように再構成する。次に、プロセスはステップ622の待機状態へ移る。しかしながら、要求した副搬送波が受諾されなければ、プロセスはステップ648へ移る。ステップ648において、移動局は、この測定期間内で要求した副搬送波としてまだ拒絶されていない、最低C/IのM副搬送波の搬送波よりも干渉が少ない新しい副搬送波が存在するかどうかを確認する。新しい候補副搬送波が存在しなければ、

プロセスはステップ622の待機状態へ移る。しかしながら、新しい候補副搬送波が存在すれば、プロセスはステップ638へ移りそこで移動局は副搬送波要求メッセージをシステムへ送信する。メッセージはステップ648で見つけた新しい候補副搬送波を新しい置換副搬送波として要求する。次に、プロセスはステップ640へ移りシステムからの返答を待つ。要求した副搬送波が受諾されるかあるいは新しい候補が存在しなくなるまで、プロセスはステップ642, 644, 648, 650および638および710, 712, 714および716もしくは718により形成されるループを継続する。次に、プロセスはステップ622

の待機状態へ移る。ACAプロセスは呼全体を通して継続され、測定タイムメッセージが受信される度に呼び出される。呼が終了すると、プロセスはステップ624および626を通過して終了する。

前記説明からお判りのように、本発明によりOFDMシステム用アダプティブチャンネル割当て方法およびシステムが提供される。本発明を使用すれば、それを実施するOFDMシステムの性能が向上する。アダプティブチャンネル割当てでは、システム上りリンクを介して測定結果を運ぶのに必要なシグナリング資源を最小限に抑え、しかもアダプティブチャンネル割当ての利点を提供するように設計されている。その結果、スペクトル効率が高く、消失呼が少なく各リンクについて良好な品質の通信を行えるシステムが得られる。

本発明の動作および構造は前記した説明から明白であり、ここに図示しかつ説明した本発明は特定の実施例として特徴付けられるものであるが、請求の範囲に明示された発明の精神および範囲を逸脱することなく変更や修正が可能である。

【図1】

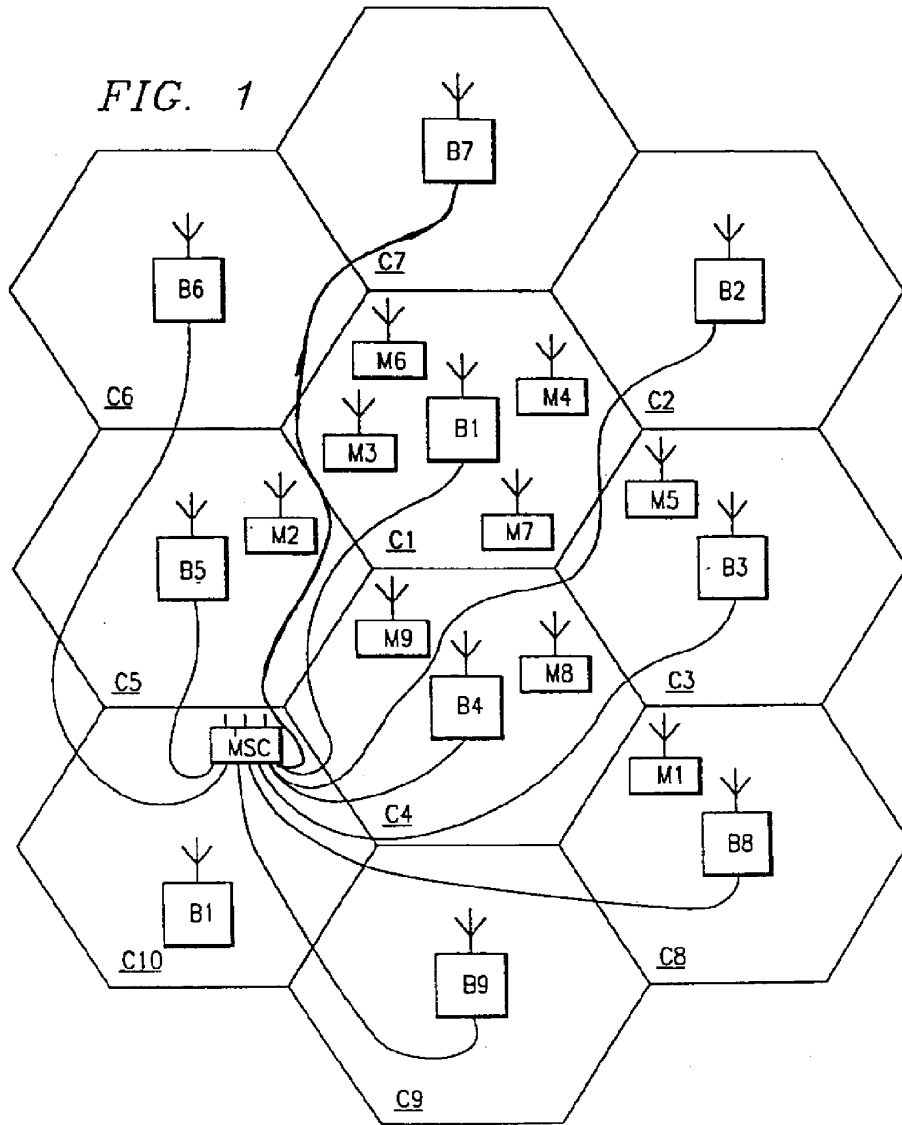

【 図 2 】

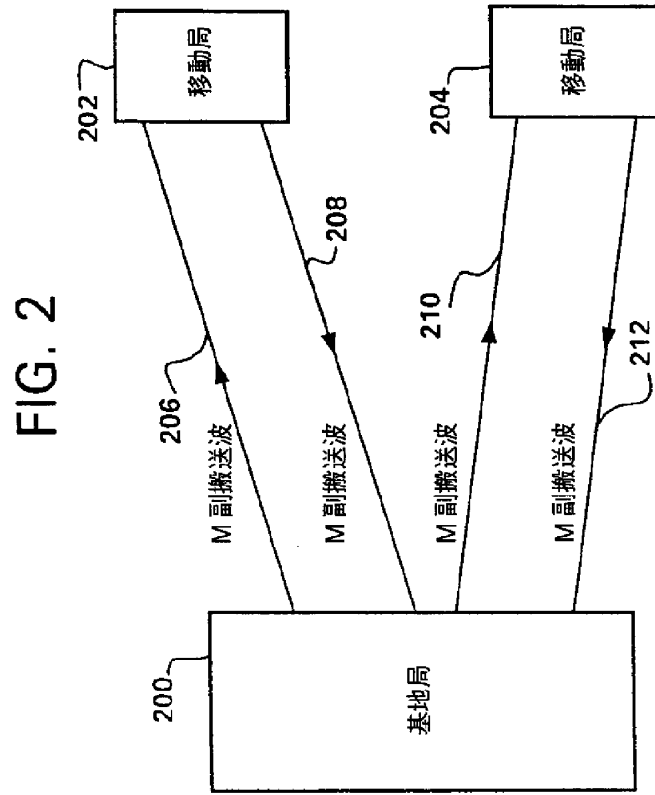

【図3】

FIG. 3A

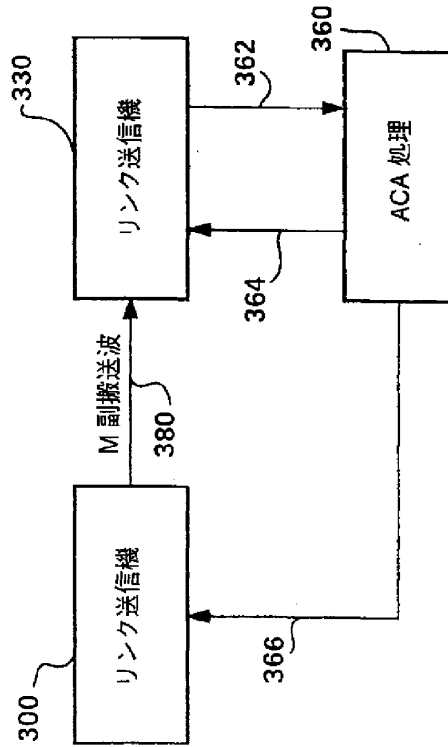

【図3】

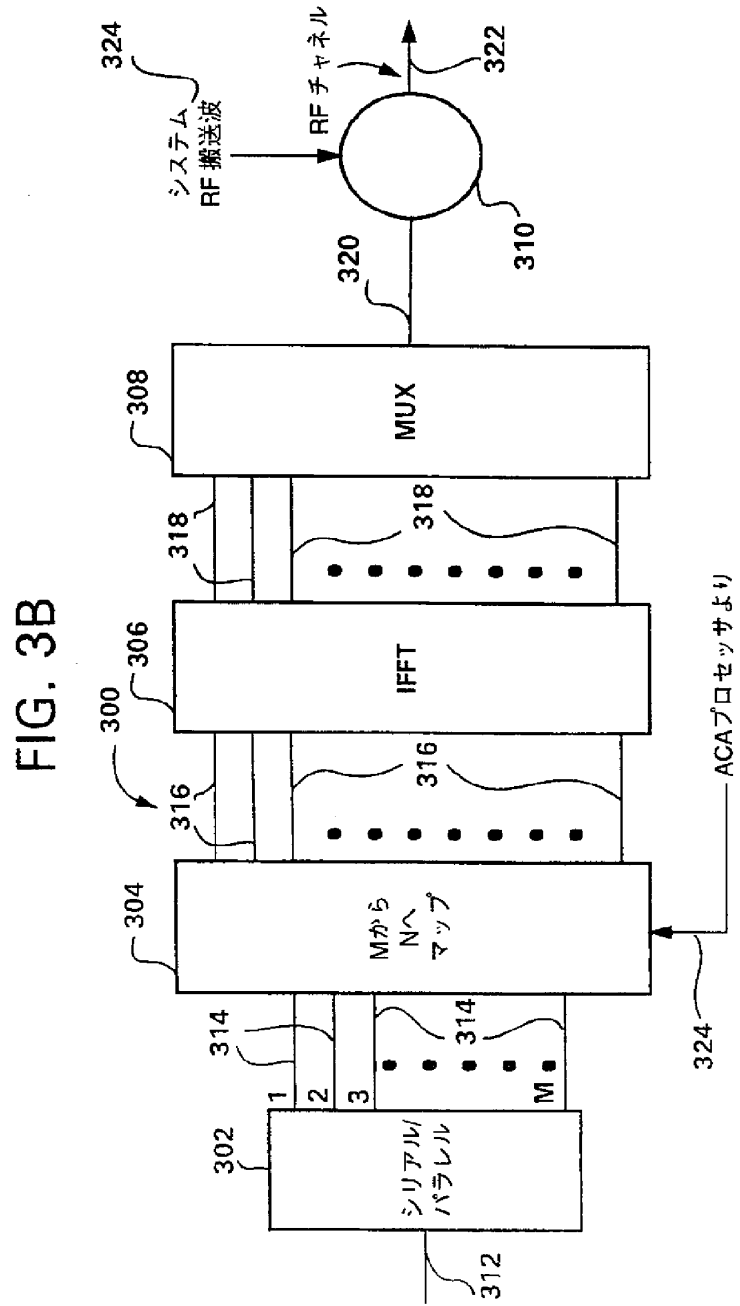

【図4】

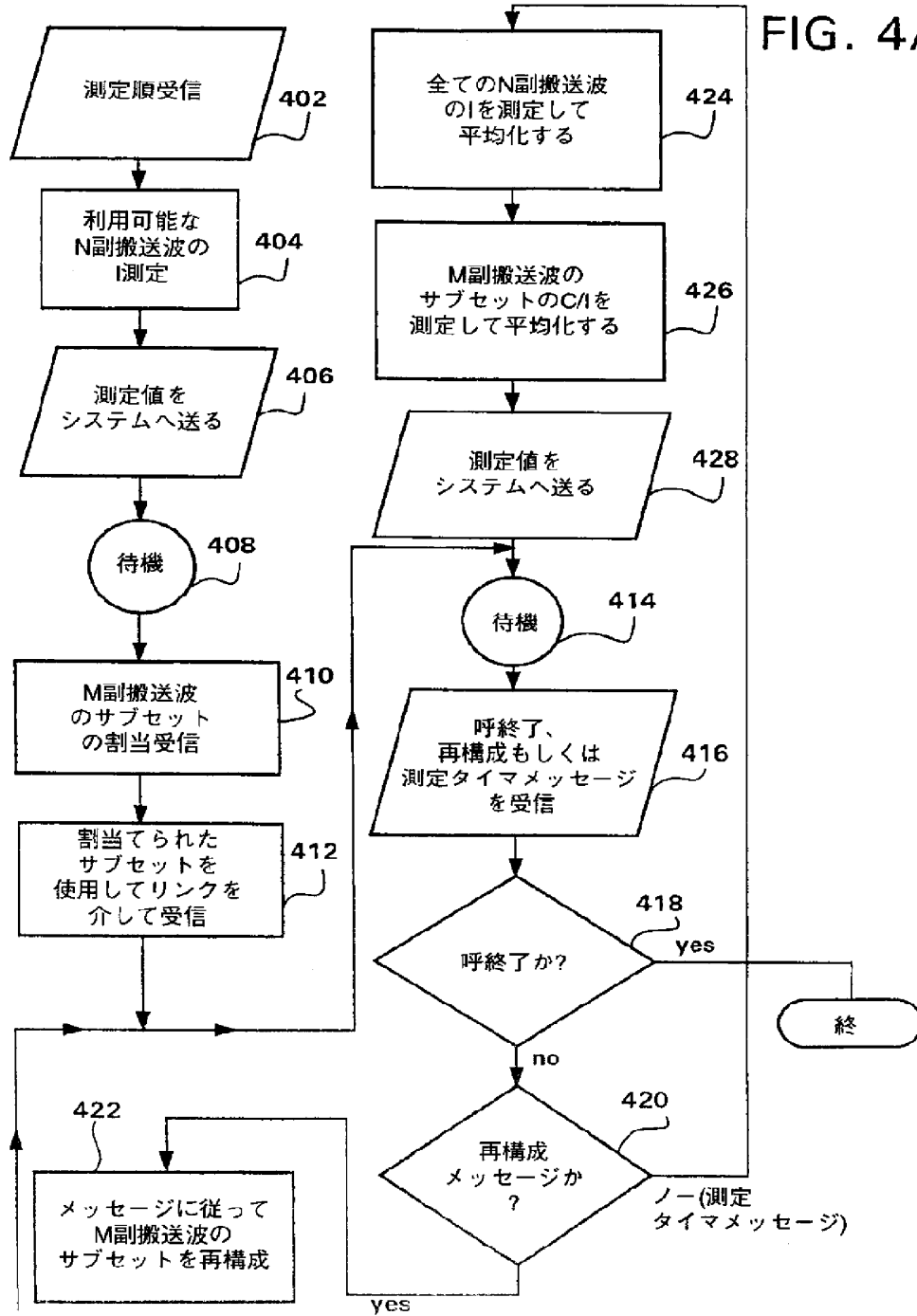

FIG. 4A