

【図6】

図 6

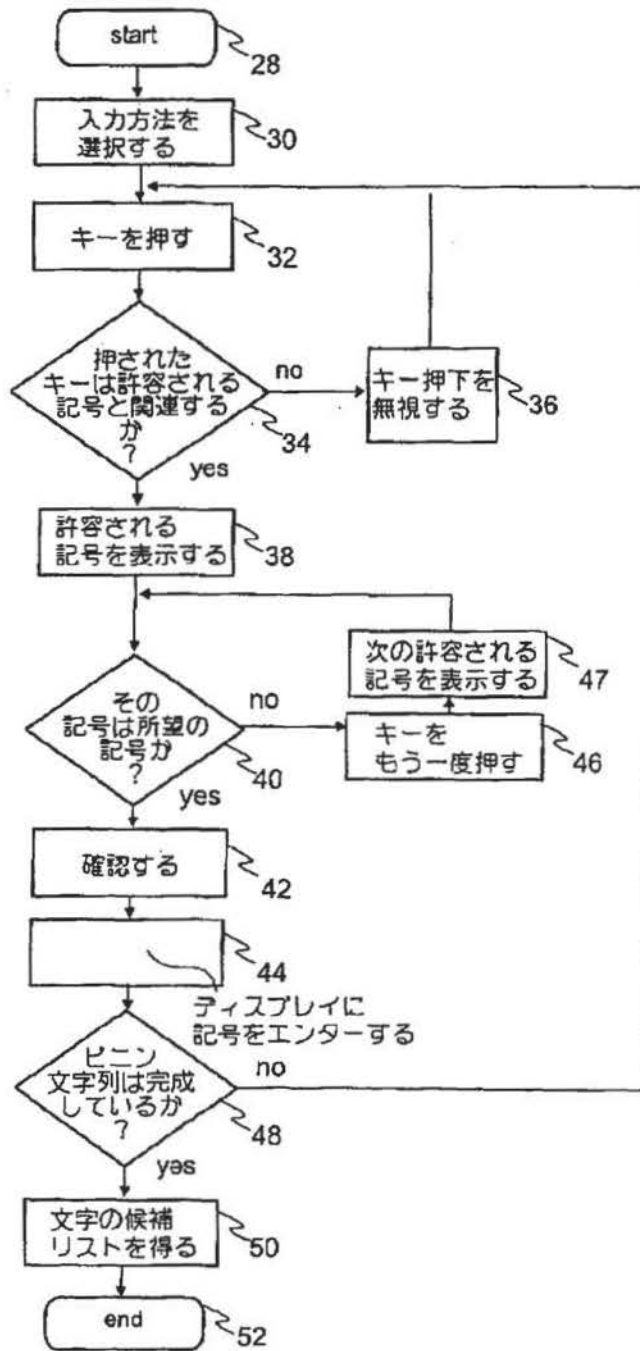

【図7】

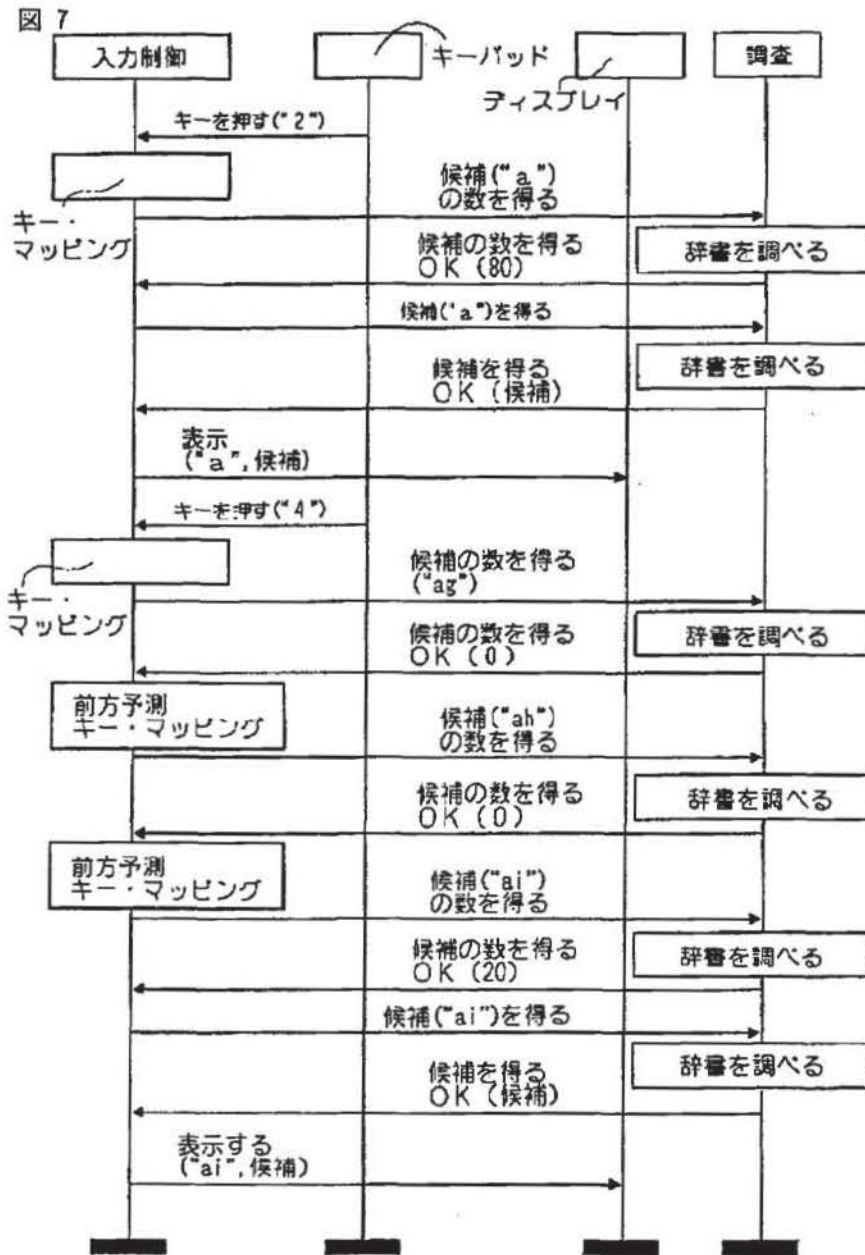

フロントページの続き

(51) Int. Cl.⁷
G 0 6 F 17/22

識別記号
5 0 7

F I

テーマコード (参考)

(72) 発明者 コウ, ヨン
フィンランド国, エフィーエン-90570
オウル, イリオピストンカトゥ 46 アー
523

(72)発明者 カオ, ニンファイ
中華人民共和国, ペイジン 100103, チャ
オヤン ディストリクト, ナンバー 1
シアンチアン ノース ロード, リビ
エラ 77

(11)Publication number :

2001-125720

(43)Date of publication of application : 11.05.2001

(51)Int.Cl.

G06F 3/023

H03M 11/08

H03M 11/04

G06F 17/21

G06F 17/22

(21)Application number : 2000-282642

(71)Applicant : NOKIA MOBILE PHONES LTD

(22)Date of filing : 18.09.2000

(72)Inventor : NI JIAN

GOU YONG

GAO NINGHUI

(30)Priority

Priority number : 1999 991989 Priority date : 17.09.1999 Priority country : FI

(54) INPUT METHOD FOR CHARACTER, USER INTERFACE THEREFOR AND TERMINAL

(57)Abstract:

PROBLEM TO BE SOLVED: To provide a method improved in efficiency

for inputting characters concerning a method

for inputting characters to a terminal.

SOLUTION: A mobile telephone has a display and

a keypad provided with plural keys. A plurality of

different symbols are related to the respective keys. This keypad is used for entering a symbol onto a display

in the form of a pinyin character string 25 and these

symbols are used for determining a candidate list 26 of

KANJI to be presented on the display later. By quickly

and continuously pressing each of keys more than once

or twice, a symbol is entered on the display. The

selection of a symbol is allowed only when this selection

is regardless of one or more symbol entered by the last

selection or combined with these symbols and

corresponds to the suitable pinyin character string 25.

The character selected out of this candidate list is entered

to a message 24 on the display.

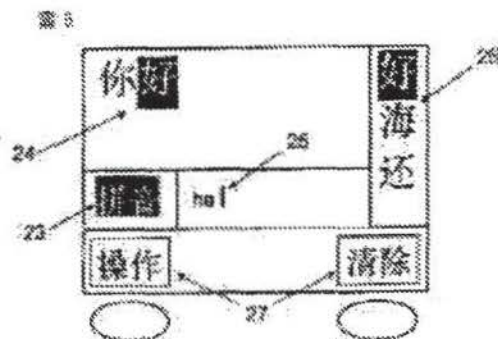

DETAILED DESCRIPTION

[Detailed Description of the Invention]

[0001]

[Field of the Invention]Although especially the present invention is not necessarily limited only to it about the input of a keyboard or the sign (symbol) from a keypad, it relates to the input of the sign which is not a part of latten alphabet. In one working example, the present invention is used for the input of the character from languages (language) of a character base (character-based), such as a Chinese Chinese character and a Japanese Chinese character.

[0002]

[Description of the Prior Art]In order to input a character (called an ideographic character) from the language of character bases, such as Chinese, a long time was quite difficult for using a keyboard. There are 20,000 or more Chinese characters and 5000-12,000 characters of them are used widely now. Therefore, it is not practical to provide the keyboard that each key and each character correspond by the couple 1.

[0003]About the present method of inputting a Chinese character into the electronic device (for example, computer) which has a keyboard, the characteristics of a Chinese character are described and using the indirect input by choosing the specific character currently instructed after that with the candidate list which a user is shown is known. This instruction is performed by the software written specially because of an input of the ideographic character called a front-end processor (Front End Processor, FEP) or an input method editor (Input Method Editor, IME). FEP interprets the input string (inputstring) from a user, and instructs the candidate list of the input string or description (description), and the Chinese character which corresponds to a user. A user will choose a right candidate from this list then (supposing it is displayed), and it is input into a display as a selected character. Candidates may be two or more characters. It may be a phrase.

[0004]The various methods of describing a character make the foundation of various Chinese character input methods. A character may be described phonographically, when a Chinese character describes the method of the pronunciation which accompanies it in that case, it is input, or a character is described by the shape of Hollerith type and a Chinese character is input by describing the chart composition or form of a character in that case. In the People's Republic of China, the method of describing the method of pronunciation is PININ (Pinyin), and this means "spelling pronunciation" literal. This is a phonographic notation of the Chinese character in the alphabet of Latin relevant to an accent mark. Another phonographic describing method (it is ZUIN (BoPoMoFo) (Zhuyin (Bopomofo)).) This is a phonographic notation of a Chinese character with 37 special BoPoMoFo signs and an intonation sign.

[0005]Since most existing Chinese character input methods were designed for PC keyboards as for origin, the number of an unformatted input sign or an input code is usually equal to the number of the key which exists in a standard QWERTY format keyboard. The lower table shows the number of the key required for some of Chinese character input methods which are comparatively popular.

[Table 1]

表 1

入力方法	解説	必要なキーの個数
ピニン (Pinyin)	発音の仕方	26+4 (抑揚のため)
ウビジキシシ (Wubizixi)	文字の形状	25
ボポモフォ (Bopomofo)	発音の仕方	37+5 (抑揚のため)
チャンジェイ (Changjei)	文字の形状	25
単純5ストローク (Simple five stroke)	文字の形状	5

[0006]

[Problem to be solved by the invention]Supposing a character input method needs many unformatted input signs from the number of the key on a keypad, the 1st step that inputs description suits an obstacle. The cause is in repeating a keystroke or two or more keystrokes being needed, in order for two or more signs to relate to one key and to input a specific sign as the result.

[0007]The problem produced by the keyboard input of a character is severe, especially concerning the character input to mobile communication terminals, such as a mobile phone. The Reason is in what the number of the key which exists in the keypad of such a terminal is restricted for (often less than 20 pieces). Since there is often more number of a required sign than 20 pieces, this causes the above-mentioned obstacle. Since the display of such a terminal is usually small, when the user of a terminal and this terminal needs to have a dialog especially in the case of an input of a sign and a character, this may become a cause and the further obstacle may arise.

[0008]The simple 5 stroke method is mentioned in the above-mentioned table 1. A stroke is the minimum graphics primitive that constitutes a Chinese character, and is a full stroke by the writing device performed without raising it from a writing face. There are five basic strokes. In the case of a mobile phone, the simple 5 stroked-input method can map the input code easily [a telephone keypad]. it -- however, it is the latest method for using.

[0009]PININ is a method which has spread in order to input a Chinese character into an electronic device. The Reason is in that it describes a character using the sign from the Latin alphabet, and there is only the method of 413 kinds of pronunciation in the national standard of the People's Republic of China, GB2312-80, and 6763 kinds of characters that are easy to come out and are used (** which does not use an intonation sign). This means that there are only only 413 vocabularies which should be described in PININ.

[0010]The example of PININ is given here. Supposing a user wants to input a that it is under [which means a "center" or a "center"] saying character, a user will input the pronunciation "zhong" of PININ using the Latin character or sign from the alphabet. FEP receives this input string and specifies some characters which have this pronunciation. It is shown to a user in the form of a candidate list, those characters, i.e., candidate. The character and candidate list of Latin

input by the user are shown in the Fig.1 showing a part of user interface. This expresses the typical state in case there are two or more candidates about the given input string. The input string of the given input method and the mean number of the candidate who corresponds are called an input coding redundant rate (Input Coding Redundancy Rate (ICRR)). Since a user receives a long candidate list about an input string so that ICRR is high, in order to discover a right character, the user has to scroll a many candidate more. If ICRR is high, the speed which can input a character will become slow.

[0011] Generally the keypad of a telephone has the key arrangement corresponding to what is shown in Fig.2. The sign (or alphabet) of a lot is assigned to most or all of this key (that is, mapped). Also about the key of a specific throat, the alphabet of the assigned sign forms queuing (queue) or the loop (loop). Within predetermined timeout duration, only the suitable number of times presses this key continuously, and a user chooses the sign of a request of the alphabet. The sign is expressed as a display. The sign will be input into a display, if the timeout duration expires or a different key is pressed.

[0012] Since inputting a symbol string into a mobile phone takes time, the method for reducing the number of required keystrokes is developed. In the method generally called T9 supplied from TEJIKKU Communications (Tegic Communications, Inc.), an input is produced as "1 Alphabet and one keystroke." A desired sign specifies the key which exists on it, and a user presses the key once. The specific alphabet of three or four signs usually relates to the key. In order to input a Chinese character, a PININ system (Pinyin System) is used for this method. Here, one example is shown. If a user wants to input PININ character string (Pinyin string) "gao", he needs to press the keys 4, 2, and 6 of a keypad. This method specifies the permissible PININ character string which can be formed by the alphabet from the keystrokes 4, 2, and 6, and displays those all to a user. PININ character strings permissible in this example are "gan", "gao", "han", and "hao". A permissible PININ character string and all the characters which correspond are displayed as a candidate.

[0013] The fault of T9 is that a candidate list long about the given input is often created. This problem will get much more bad, if an input string becomes short. for a Chinese input, T9 corresponds with either of the combination possible about the pressed key -- if it becomes, the list of all those Chinese characters will be shown. For example, if the keys 7 and 4 are pressed, all the characters accompanying "pi", "qi", "ri", and PININ of "si" will be displayed, and this will make a very long candidate list.

[0014] T9 has other faults. This is responding to a user input and not giving clear feedback. Since it is an interactive process in which a user can correct an input based on the candidate list currently displayed, it is a usually desirable thing in a Chinese input. Although T9 is tackling the problem of the duplication keystroke for a PININ input, it pays the sacrifice that a candidate list becomes long, therefore ICRR becomes high, and performs it. This means that a long candidate list must often be scrolled, in order to discover a desired Chinese character. Since this fault restricts a candidate's number which a small display can display at once, it is a problem especially in a mobile phone.

[0015]T9 is applied also to the BoPoMoFo input, and 37 BoPoMoFo signs are assigned to the key of the keypad of a telephone, or it is mapped. There is problem same with having mentioned above about PININ, and mapping of the keypad of BoPoMoFo also has the further problem that it is random on the whole, from a user's standpoint. There is no method of getting to know simply where for the user, when the sign of BoPoMoFo is not printed by the keypad due to space, especially as for all, each BoPoMoFo sign is arranged.

[0016]The input method sensitive to the context which predicts the following Chinese character according to the context and a Chinese database is used for other methods used for the input of a Chinese character. In this method, analysis is performed on not the level of a sign but the level of a Chinese character (ideographic character) which were input. This method can be described in the following example. The example is simply shown in English for the purpose of a description.

[0017]A user wants to input a text called "read book". After a user inputs the word of "read", software is likely to continue after "read", for example, carries out the prompt of the word of "book", "newspaper", etc. It will be chosen by the user if a right word is displayed.

[0018]The method of inputting a sign and a character is GB 2. 333 It discloses in No. 386. The probability table which gives the list of signs of the biggest Latin of a subsequent possibility after [each] 26 Latin signs and a "space" sign is provided by the terminal. When inputting a Latin sign during the input of a text, a user is shown the list of signs of all the Latin not in a default, for example, alphabetical order, but in an order determined by the probability used as the following sign. The fault accompanying this method is that a user is shown the long symbol list which chooses a specific sign from it.

[0019]It is clearly desirable to provide the efficient method of inputting a character. The method should be [that it is easy to master] easy-to-use, and its ICRR must be low, and its average input code length per character must be short. It is difficult to provide the character input method which the above-mentioned necessary condition has often been mutually contradictory unluckily, and can be efficiently used for all the elements.

[0020]

[Means for solving problem]According to the first mode of the present invention, the method of inputting a character into a terminal is provided, The terminal has two or more keys, at least one of the keys expresses several different signs, and use of the key for pre- sign (previous) selection is used in order to determine the sign with which it is expressed by a selectable key in the next selection (subsequent).

[0021]The term of a "sign" (symbol) contains all the graphic marks (graphic glyph) that can carry out a direct entry from a keyboard or a keypad. A sign includes fundamental character input elements, such as the alphabet, Arabic numerals and the BoPoMoFo sign, a character stroke, and an intonation code. The direct entry of the sign can be carried out from a keyboard, and it does not need FEP. For example, characters, such as a Chinese character, must be input via FEP.

[0022]Preferably, the alphabet of a different sign is related, in a display, this sign can be accessed in the operation which presses 1 time, several key choices, or a key, or this sign can be

displayed on some keys. The result that pre-selection is limited to the alphabet about the key beyond 1 or it or the alphabet of a sign may be brought about.

[0023]The key used for pre-selection may be the same as the key used for the next selection. Or this key may be different. The sign in the next selection may be the same as the sign in pre-selection, and it may be different.

[0024]Preferably, this method is used in order to input an ideographic character. It can be used in order to input a Chinese character. Or it may use in order to input other characters, such as what is used in it in Japan (Chinese character), South Korea, or other areas. This method is not limited only to the input of a character, and it may be used in order to input a character and to form Latin alphabetic word.

[0025]According to the second mode of the present invention, the user interface for inputting a character into a terminal is provided, This terminal has two or more keys, and at least one of those keys expresses several different signs, It is possible to choose a sign by performing first selection using a key, and a processor is used in order to determine the sign with which it is expressed by a selectable key in the following second selection.

[0026]According to the 3rd mode of the present invention, it is provided by the terminal for receiving a character input and this terminal, A processor and two or more keys are included and at least one of those keys expresses several different signs, It is possible to choose a sign by performing first selection using a key, and in order to determine the sign with which it is expressed by a selectable key in the following second selection, the above-mentioned processor is used.

[0027]Preferably, this terminal is a moving terminal. It may be a terminal which accepts the input from two or more keys of a mobile phone, smart telephone (smart phone), and personal digital assistant, laptop, electronic Note Pad (electronic notepad), a pager, or others. In the embodiment whose it is a mobile phone, it may be a cellular mobile phone linked to a cellular phone network.

[0028]The present invention is suitable for especially the terminal that has a small keypad. the present invention -- small size -- the key of a keypad -- it means that two or more signs relate to inner either. It may be about 12 keys, and in a certain working example, it may be less than 20 keys and the thing of exclusive use [eye / others] may be [this may be used for an input of a sign or] sufficient as it.

[0029]In the present invention, it is considered that all the elements already input by the user are fixed unless it is right and a user corrects them intentionally. It only predicts the following sign which may appear. It is forward prediction (forward-prediction) and does not change the already input input.

[0030]A little number of times of a keystroke required in order that the present invention may input a sign compared with T9 method may be increased. However, since the present invention gives IRCC smaller than T9 to the amends, the total of a keystroke required in order to discover a specific Chinese character decreases. A candidate list may decrease only about 50%. This gives an advantage remarkable in the equipment which has a sized display. This is because it is

difficult to scroll a candidate list with such equipment and it is rather a low speed. If it considers that 1 time of the step which scrolls to a top or the bottom is a keystroke, there may be few keystrokes which this invention needs than T9 method. The present invention gives a user clear feedback, in order to guide an input or to give the display of errors.

[0031]An example is given with reference to an accompanying drawing, and the present invention is described.

[0032]

[Mode for carrying out the invention]Fig.1 and 2 were discussed before.

[0033]Fig.3 is abbreviated-illustrating the functional hardware block of a terminal unit. In this working example, especially a terminal is the mobile phone 1. This hardware block is controlled by the controller 2 which runs an operating system. Various software, applications, and data are memorized by the random access memory (RAM) 3 and the read-only memory (ROM) 4. This telephone is transmitted and received via the transceiver block 5. Operation relevant to audio processing is performed in the audio portion 6 connected with the receiver 7 and the microphone 8. Other elements, such as the Subscriber Identity Module (SIM;Subscriber Identify Module) card 9, the display 10, and the keypad 11, are controlled by the controller 2. Software realizes and FEP is included in RAM3 and/or ROM4. The command given by the software is executed by the controller 2, in order to control the display 10 and the keypad 11.

[0034]Fig.4 shows the system configuration of the terminal of Fig.3 and shows the sign and the portion relevant to the input of a character, especially the portion containing FEP of this terminal.A system configuration The four modules 12, i.e., an input control module, It can divide without the engine investigation (look-up) module 14, the keypad input unit 16 for enabling the input to the input control module 12, and output units, such as the display 18. In addition to these four modules, the engine investigating module 14 is connected to the Chinese input dictionary 20, and this dictionary contains the PININ character string and the mapping table of the Chinese character which corresponds. In order to search a Chinese character from the given PININ character string, the Chinese input dictionary can be used for an engine investigating module. In the case of the Chinese dictionary, it includes all the lists of possible PININ character strings.

[0035]In this working example, FEP contains the portion 12 used in order to process the alter operation performed when a Chinese character is input, i.e., an input control module, the engine investigating module 14, and the Chinese input dictionary 20. The terminal contains an interface module, and other operating systems and applications 22. Other interface modules are used in order to control the interface between a user and a terminal for operation of others, such as a thing relevant to a telephone. With an operating system and application, it is used in order to control operation with FEP and other portions of terminals, such as a portion relevant to a telephone.

[0036]Before a sign enters the display of a terminal, the sign which can turn into an appropriate (valid) start symbol of a PININ character string can be chosen from a keypad, and a display can be entered. The sign u, v, and i cannot be used as a guidance character of a PININ character string. Only the sign with which the terminal can make a start symbol and appropriate PININ

combination when the following key is pressed after the input of a start symbol may be chosen by the user. It is limited to several [of the alphabet relevant to the key on a keypad / at least], and it becomes impossible therefore, for a user to use all of the signs. A user's push of the following key will instruct the signs which can be used from the selected alphabet one by one to a user (prompt). Actually, this input method predicts the following possible alphabet, and makes impossible selection of the sign which cannot form an appropriate PININ character string.

[0037]In one working example, determination [/ which sign can be chosen from a keypad] is performed by the engine investigating module 14. In this case, the engine investigating module 14 knows which sign is mapped by which key of the keypad. Therefore, the details about which key was pressed are only passed to the engine investigating module 14. For example, if character string "ga" enters a display and a user will press sign "m" and the key "6" connected with "n" and "o", The input control module 12 tells that this key was pushed on the engine investigating module 14, and investigates whether PININ character string choice "gam" which can be used, "gan", and "gao" are appropriate to the engine investigating module 14 with Chinese dictionary 20. If a first appropriate character string (in this case, "gan") is discovered, it will be told to the input control module 12 that the engine investigating module 14 displays sign "n" on a display.

[0038]In this example, determination about the thing which sign is selectable is performed by the input control module 12 from a keypad. In order that the operation which pushes key "6" after "ga" may investigate whether it is appropriate to the input control module 12 in character string "gam" in the subsequent above-mentioned example, ** "gam" is sent to the engine investigating module 14. Since it is not an appropriate character string, the engine investigating module 14 sends the response of the meaning to the input control module 12. Then, an input control module sends following character string "gan". Since this is an appropriate character string, the engine investigating module 14 tells the input control module 12 about that, and "n" is expressed as a display after character string "ga" which has already entered. Actually, the user may desire to enter character string "gao", a user pushes "6" again in that case, and the input control module 12 sends character string "gao" to the engine investigating module 14 as the result. Since it is a character string as which this may also be admitted, an input control module is told and "o" is expressed as a display instead of "n."

[0039]Compared with a standard Chinese input method, each of these working examples does not increase memory consumption, or does not increase a calculation overhead.

[0040]Fig. 5 shows the Chinese input display by the present invention. This shows various zones of the display, and those contents while editing a short Chinese message. The input condition indicator 23 which a display zone shows the present input condition, The editing window 24 where a user's text is displayed and edited into it, It is with the input window 25 which input strings, such as PININ, are displayed on inside and edited, the candidate window 26 where an input string and the candidate that corresponds are displayed on inside, and the window 27 for text displays relevant to a function key. The window 27 specifies the function of two keys which are placed directly under a text. Since a candidate is highlighted before choosing a candidate and entering on a display, the user can scroll the candidate in the candidate window 26.

[0041]The input of the sign and the character is shown in Fig.6 in the form of the flow chart. Operation begins from the first step 28. In Step 30, a user chooses an input method, in order to input a character using the input control module 12. For example, it may be an input of the Chinese which uses the PININ method. Once the input method is started, a user will press the key containing the sign of the request which is a start symbol of a desired PININ character string at Step 32. Using the Chinese input dictionary 20, the engine investigating module 14 is Step 34, and determines whether it is a thing relevant to the sign with which the pressed key is permitted. If not connected with the sign with which the pressed key is permitted, in Step 36, in the bottom of the key press, it will be ignored and any sign will not be displayed on the display 18 of a terminal, either. In this case, a terminal waits for a user to press other keys. If connected with the sign with which the pushed sign is permitted, in Step 38, the first thing of the signs relevant to the key permitted will be expressed as a display. Of course, if the number of the signs relevant to the pressed key permitted is one, it will be expressed as a display. Since the sign which entered can form an appropriate PININ character string (part) from the time of a first sign being displayed on a display, a candidate list is shown by the display. A candidate list can be displayed even if it is before a user checks that the sign currently displayed on a display should enter a display in this way. By this, since a character can be chosen from a character list even if it does not press other keys, in order for a user not to wait to be timing out, or to enter a sign, time will be saved. In a flow chart, a candidate is displayed from the time of a sign being displayed on a display in Step 38. Therefore, a user receives the immediate feedback about his input from a candidate list. In Step 40, a user determines whether the sign currently displayed is a desired sign, seeing the sign currently displayed on the display. If it becomes so, a user will check the fact at Step 42 waiting for the timeout duration relevant to selection of a sign to pass, or by pressing the suitable selection key on the keypad input unit 16. A selection key may be a key currently specially assigned to work of checking selection, or may be other keys for only inputting a sign. In Step 44, a terminal enters as a sign which had the sign of a display chosen. If the sign currently displayed is not a desired sign, in Step 46, a user will display the sign which presses the key once again and with which the next is permitted (Step 47), and will investigate once again whether the sign currently displayed is a desired sign. The engine investigating module 14 should remember using the Chinese input dictionary 20, in order to make it possible to choose only the sign which makes an appropriate PININ character string. Therefore, the user cannot choose the sign which is not permitted. It tries in order that a user may discover a sign, and if it cannot do so, that can start the instruction that spelling of a PININ character string is wrong in something, for example. Thus, a terminal gives a user feedback. It should be cautious of this feedback being given during formation of a PININ character string, and not being given after the input of all the signs showing a PININ character string is completed. This is contrastive with T9 method. If a sign enters the display 18, a user will investigate whether the PININ character string is completed in Step 48. If that is not right, a user will press other keys at Step 32, will choose other signs, and will repeat the procedure of sign selection. In Step 50, FEP of a terminal is used in order to obtain the candidate list of a character from the completed PININ

character string. As mentioned above, before a character is chosen from a candidate list, the completed PININ character string can be entered, however the user can choose a character from the time of it being displayed at Step 38 for the first time at any time. Operation is finished with the final step 52.

[0042]If a sign is chosen and a display is entered by pressing other keys and beginning other sign selection process procedures in Step 42, Procedure is resumed by this from Step 34, namely, the engine investigating module 14 investigates whether it is connected with the sign permitted by the pressed key.

[0043]In addition to the above-mentioned step, when change is needed, the step for deleting a sign or a character is also provided. The sign in the character string which entered spells it, and it is a result of a mistake, or is the result of being because the user's near idea having changed. Such a compensation process procedure in the user interface of a terminal is well known to a person skilled in the art, and may adopt what kind of publicly known method.

[0044]:1. described next about the command produced between the input control module 12, the engine investigating module 14, and the Chinese input dictionary 20, and the sequence of a notice A user presses a key. In this case, key"2" is pushed.

2. A keypad accepts the phenomenon in which there was the keystroke. Then, a keypad sends the phenomenon to the input control module 12. In this case, I hear that key"2" was pushed and that phenomenon exists.

3. The input control module 12 applies a new input symbol to the input buffer of the module 12 according to the quota symbol sequence (sequence) of the pressed key. In this case, sign"a" is added to this buffer.

4. An input control module passes an input string to the engine investigating module 14, and asks for the number of the input string and the candidates that correspond.

5. The engine investigating module 14 returns the number of the candidates who investigate the input string from an input buffer in the Chinese input dictionary 20, and correspond to the input control module 12. In this case, character string"a" from an input buffer is investigated in the Chinese input dictionary 20.

6. The input control module 12 counts the number of the candidates who correspond. In "a", the number shows largely that it has an input string and a candidate that corresponds from zero. The input control module 12 requires a candidate from the engine investigating module 14.

7. The engine investigating module 14 obtains a corresponding candidate with reference to the Chinese input dictionary 20, and passes them to the input control module 12.

8. The input control module 12 displays an input string and the candidate relevant to it on the display of a terminal. In this case, input string"a" and its candidate are displayed.

9. A user presses the following key. In this case, key"4" is pushed.

10. the keystroke phenomenon, i.e., a key, -- "4" was pushed -- it ***** . Then, a keypad sends the phenomenon to the input control module 12. Steps 3-5 are repeated. An input string serves as "ag" now.

11. The input control module 12 counts the number of the candidates who correspond. In this

case, it is zero. If a candidate list is empty, the input control module 12 will not display a new input character at all. Therefore, sign "g" is not displayed. The input control module 12 investigates the following sign relevant to the pressed key.

12. Steps 3-5 are repeated. An input string changes to "ah" shortly. There is no candidate also in this.

13. The input control module 12 counts the number of the candidates who correspond. In this case, it is zero. An input control module investigates the following sign relevant to the pressed key.

14. Steps 3-5 are repeated. An input string changes to "ai".

15. Since "ai" is an appropriate character string, Steps 6-8 are repeated.

[0045] These steps are shown by the message inspection sequence chart of the Chinese input of forward prediction in Fig.7. Of course, in the end of the sequence, it is admitted as an input with appropriate one of the character in the candidate window 26, and a display is entered.

[0046] The user control module 12 has the knowledge about a keypad and the sign relevant to various keys, and an engine investigating module performs the role which investigates an input string in the dictionary 20. The input control module 12 supplies the sign of the pressed key to the engine investigating module 14 in order with a pre- input until an engine returns to the number of candidates which is not zero (i.e., until it discovers at least one match). Of course, if not all the sign relevant to the pressed key is also appropriate, an engine investigating module will continue supplying the number of candidates of zero. The input control module 12 controls the keypad input unit 16 and the display 18 so that the alphabet limited suitable for the key of the keypad input unit 16 can relate and choose.

[0047] As the description about the flow chart of Fig.6 described, Saki whom the perfect PININ character string of the character enters can also input a Chinese character. For example, if the Chinese character accompanied by PININ character string "gao" should be input, the user can scroll the candidate in the candidate window 26 promptly, if an appropriate PININ character string is input (though it obtains with it and is only one character). Therefore, a user can discover character "gao", after inputting only "g" or "ga". Of course, such a "partial input" brings about a longer candidate list, and it increases IRCC. These characteristics are useful, when a PININ character string with a perfect user cannot be remembered or that whole character string cannot be input.

[0048] The following table 2 shows the keystroke required to input PININ character string "zhong", when using the method by the present invention.

[Table 2]

[0049] When there is no prediction method, the keystroke which enters PININ character string "zhong" serves as "9999-44-666 - the timeout 66-4" using keypads, such as what is shown in Fig.2. However, when the prediction method by the present invention is used, a required keystroke is "the 9999-4-6-timeout 6-4."

[0050] The following table 3 presents the statistics which show the performance of the method by the present invention contrasted with the fundamental input method which uses neither prediction nor statistical strengthening (statistical enhancement) for sign selection. Actually, these statistics show the input efficiency of the all directions method. These statistics are based on 405 PININ character strings used in total for 7513 common Chinese characters. This table 3 is comparing the number of keystrokes required to input those PININ character strings by an ordinary keypad using the average length of the perfect PININ character string about all the characters, and a fundamental input method and the method of the present invention. The overhead of the keypad input is also calculated assuming that the best method needs only 1 time of a keystroke for each input of a sign.

[Table 3]

[0051]The weighting mentioned in the top is calculated as follows. That is, L_p is this PININ string length given with the number of the sign in a PININ character string. P -- the total of an appropriate PININ character string, i.e., the size of lexical space (vocabulay space), -- it comes out. It is the number of the Chinese characters with which N_p has the same PININ character string about each PININ character string. Therefore, average PININ length is (sum total of L_p)/(total of appropriate PININ character string) = $\sigma L_p/P$. A weighting average is calculated as (total of $N_p \cdot L_p$)/(total of character) = $\sigma(N_p \cdot L_p)/\sigma N_p$. When calculating a string length, this weighting average is prescribed that a big weight is applied to this PININ character string rather than corresponding with more characters. The weighting also of the number with which the keystroke mentioned above corresponds is carried out similarly.

[0052]It turns out easily that it is what decreases an average keystroke for the present invention to input a perfect PININ character string by two or more keystrokes. This is about 30% of the ordinary number of input keystrokes. The overheads of a stroke decrease in number about 60%. These improvements should be cautious of being attained without increasing IRCC.

[0053]The present invention is based on the fact that input coding space (input coding space) is the closed set (closed set) which always has a limited number of codes, about many of character input methods (especially the PININ method) used in order to input a Chinese character. If it puts in another way, the input method usually has a vocabulary of an input method itself [that was built with the fundamental input element or the sign / this]. Those vocabularies always have the pattern or the characteristics of a vocabulary itself [this].

[0054]The present invention simplifies the input of PININ to a mobile hand set provided with the small keypad with which the alphabet of a sign is related to one key, or other equipment remarkable. In key mapping designed carefully, the 12 present invention can also improve Chinese input methods, such as UBIJIKISHIN (Wubizixin) besides having many input codes (for example, BoPoMoFo).

[0055]Although the preferable working example of the present invention has been illustrated and

described, it will only be understood that the working example was described as a mere example. The person skilled in the art will think out many deformation, change, and substitution, without deviating from the range of the present invention. For example, the present invention is described with the alphabet limited in order to provide the high input of efficiency, however in other working examples, in order to improve an input method further, it can also provide an additional Chinese character level intelligence input method. Various methods can be used in order to investigate whether a specific sign is appropriate as a following choice. It can be performed by consulting a Chinese input dictionary, as described in the above-mentioned working example. Or it can also be performed under the rule based on the knowledge about language. Although the present invention was related with the Chinese input and described, the present invention is not limited only to the character of this language. In the above-mentioned description, although the term of a dictionary was used, it should be understood that some dictionaries may be provided for some various languages or various kinds of character inputs. The present invention is applicable also in order to input the word of what kind of language actually formed by using the character from the Latin alphabet. Probably, such an embodiment needs a means to investigate whether it is appropriate because of the word which the suitable database about a word and the following character are building. Determination [/ which sign can be chosen from a keypad] is described as what is performed by either an engine investigating module or the input control module, however can also unify those modules to a single functional unit. Therefore, in Claims, it is considered as all the things belonging to the range of the present invention which reach and include others' deformation.

An Efficient Text Input Method for Pen-based Computers

Toshiyuki Masui

Sony Computer Science Laboratory Inc.
3-14-13 Higashi-Gotanda
Shinagawa, Tokyo 141-0022, Japan
+81-3-5448-4380
masui@csl.sony.co.jp

ABSTRACT

Pen-based computing has not yet taken off, partly because of the lack of fast and easy text input methods. The situation is even worse for people using East Asian languages, where thousands of characters are used and handwriting recognition is extremely difficult. In this paper, we propose a new fast text input method for pen-based computers, where text is not composed by entering characters one by one, but by selecting words from a menu of candidates created by filtering the dictionary and predicting from context. Using our approach, users can enter Japanese text more than twice as fast as recognition-based and other existing text input methods. User studies and detailed analysis of the method are also given.

KEYWORDS: Input devices, Pen-based input, Predictive interface, Hand-held devices, International interfaces, POBox

INTRODUCTION

Although a variety of pen-based computers are available these days, they are not as widely used as keyboard-based computers, partly because entering text is much harder on pen-based machines. Traditionally, handwriting recognition techniques and the soft keyboard (virtual keyboard displayed on the tablet of a pen computer) used to be the main techniques for entering characters on pen-based computers, although other techniques have also been proposed[4][6]. However, using any of these techniques takes much longer to enter text than with a standard keyboard.

The situation is worse for East Asian languages such as Chinese, Japanese, etc. These, unlike European languages, have thousands of character faces. Even with a keyboard, it is not easy to enter a character. A variety of techniques for entering text into computer have been investigated. The most widely-used Japanese input technique is "Roman-Kanji conversion" (RKC), in which a user specifies the pronunciation of a word with an ASCII keyboard, and the system shows the user a word with the specified pronunciation¹. If the word

¹Japanese characters consist of two character sets. Kanji characters,

was not the one that the user intended to use, the user types a "next candidate key" until the correct word appears as the candidate.

On almost all the pen-based computers available in Japan, either RKC or handwriting recognition is supported. Text input is slow and tiring using either of the techniques, for the following reasons. Specifying the pronunciation of every input word using a soft keyboard takes a lot of time, and the user must convert the pronunciation to the desired Kanji strings with extra keystrokes. Handwriting recognition has more problems. First, the recognizer has to distinguish between thousands of characters, often making errors. Many of the characters in the character sets have similar shapes, so it is inherently difficult to make recognition reliable. Second, in many cases, users do not remember the shape or the stroke order of Kanji characters, even when they have no problem reading them. Finally, writing many characters with many strokes on a tablet is very tiring. With these difficulties, it is believed to be difficult to enter Japanese text faster than 30 characters a minute on pen-based computers, which is several times slower than using keyboards.

We have developed a new pen-based text input method called *POBox* (Pen-Operation Based On eXample), where users can efficiently enter text in any language, using menus, word prediction and approximate pattern matching. The remainder of this paper demonstrates the details of *POBox*.

STRATEGIES FOR RAPID TEXT ENTRY

There is a big difference between the speed of typing on keyboards and pointing to characters on soft keyboards of pen-based computers. Computer users can easily type more than five characters per second, while it is very difficult to touch three character keys per second, accurately on the soft keyboard of a pen-based computer. In contrast, the speed of selecting an item from a list is faster with a pointing device, and many keyboard-oriented text editors (e.g. Emacs) now have mouse interfaces. For this reason, forcing the user to enter many characters should be avoided on pen-based computers, while a better approach should allow the user to select a word from a list of candidates, in a minimum number of penstrokes. We took the following approach.

imported from China, contain both meaning and pronunciation, while Kana characters only represent pronunciation.

Published in:
Proceedings of the ACM Conference on Human Factors in Computing Systems (CHI'98) (April 1998), ACM press, pp. 328-335.

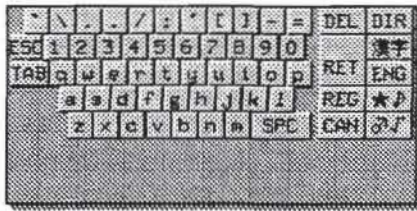

Figure 1: Initial display.



Figure 2: Selecting the "F" key.

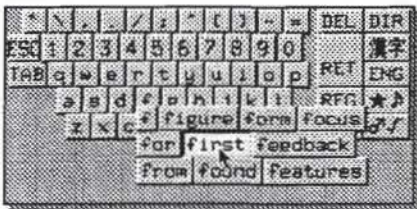

Figure 3: Selecting "first" by dragging.

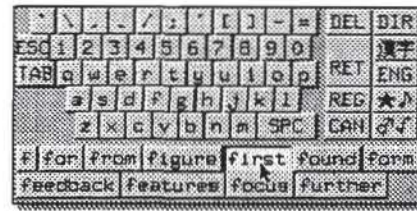

Figure 4: Selecting "first" after releasing the pen from the tablet.

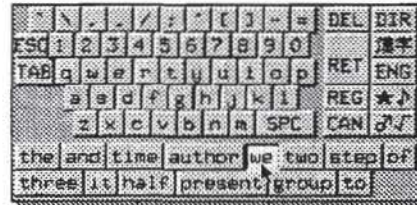

Figure 5: Selecting "we" after selecting "first".

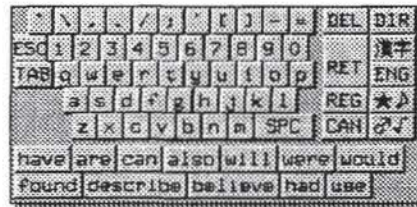

Figure 6: After selecting "we".

Using dynamic menus to show candidates and select words: The desired word can be picked up directly from a pulldown or popup menu.

Dynamic query for dictionary search: As soon as the user specifies a portion of the pronunciation or the spelling of a word using the soft keyboard on the tablet, POBox shows a menu of candidate words that match the input.

Using term frequency and example phrases: The words which are most likely to appear at the insertion point in the text are shown at the top of the menu. The likelihood is calculated from the term frequency and context. For example, since the word "interface" tends to come after "user," it appears at the top of the menu after the user has selected "i" as the first character following "user."

Dynamic approximate string matching for selecting candidate words: If the pattern specified by the user does not exactly match any of the words in the dictionary, POBox automatically performs approximate string search based on the following two strategies. One is *spatial approximation*, where adjacent characters on the soft keyboard are treated equally in the search. This strategy is effective especially when the soft keyboard is small and precise selection is difficult. For example, if the user failed to tap the right position of a soft keyboard and selected "dtns" to enter "dynamic," no word in the dictionary matches "dtns" and POBox automatically searches the dictionary using the less strict pattern "[ersdfxc][rtyfg][hjbnm][weasdzx]," based on the arrangement of ASCII keyboard. ("d" key is surrounded

by "e," "r," "s," "f," "x" and "c" keys.) This pattern matches words like "synergy" and "dynasty," but since "dynamic" has higher term frequency than these words, it is shown in the candidate word list for the selection. The other is *pattern matching allowing errors*. This strategy is effective when the user does not remember the correct spelling or the pronunciation of a word. In this case, POBox automatically looks for words whose spelling or pronunciation is closest to the pattern and shows them as candidates. Users can even specify only a portion of a word to get the desired word in the candidate list.

Simple dictionary adaptation: Newly selected words are put at the top of the dictionary, and are likely to be shown at the top of the menu so that the dictionary reflects the characteristics of the current text.

EXAMPLES

Entering English Text

First, for explanatory purpose, we show how to use POBox for entering English text, although POBox is more effective for entering Japanese and other East Asian languages. We used the ACM CHI'95 Electronic Proceedings CD-ROM to create an English dictionary with term and phrase frequencies. We extracted plain text files from all the HTML files in the CD-ROM, counted the occurrences of words and word combinations, and created the dictionaries by sorting the entries by frequency order. The remainder of this section uses the sentence ("First, we show our technique for entering English text.") as the sample input text for our example.

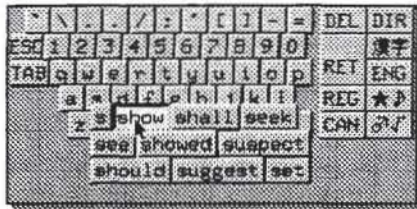

Figure 7: Selecting "show" from the menu.

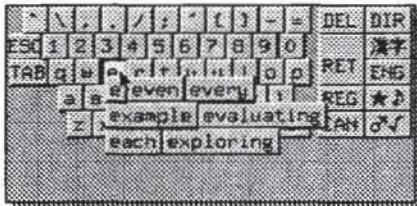

Figure 8: Selecting the "E" key.

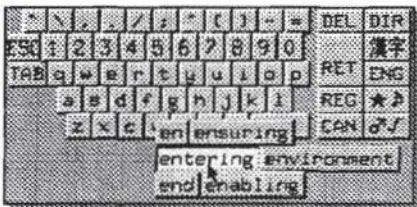

Figure 9: Moving to the "N" key and selecting "entering".

Figure 1 shows the startup display of POBox. When the user touches the "F" key, the display changes to Figure 2, showing the frequently used words that start with "F" in a pull-down menu. Since the word "first" is a frequently used word and is found in the menu, the user can drag the pen and highlight the word "first" as shown in Figure 3, and then take the pen off the tablet to complete the selection. Alternatively, if the user does not make a selection from the pull-down menu of Figure 3, he can choose the desired word from the popup menu as shown in Figure 4.

After selecting "first", the display changes to Figure 5. In the menu at the bottom, the words that often come after "first" are listed in order of frequency. The word combination "first the" appears 27 times in the CHI'95 CD-ROM, "first and" and "first time" appear 20 times, etc. Since the next word, "we," happens to be in the list because "first we" appears 13 times in the CD-ROM, the user can directly select "we" by touching it in the menu. After selecting "we", the display changes to Figure 6. In this case, "show" is not found in the menu, but it can be selected from the pull-down menu by touching the "S" key as shown in Figure 7.

After this, "our", "technique" and "for" can be selected in a similar manner. Touching the "E" key does not make the system display the next intended word ("entering") as shown in Figure 8, but touching the "N" key next narrows the search space of the dictionary and "entering" then appears in the menu for the selection (Figure 9).

From start to finish, the user only had to tap the tablet 15

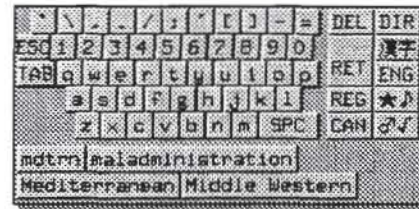

Figure 10: Specifying "mdtrn" to get "Mediterranean".

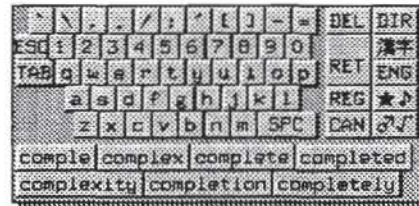

Figure 11: After specifying "comple".

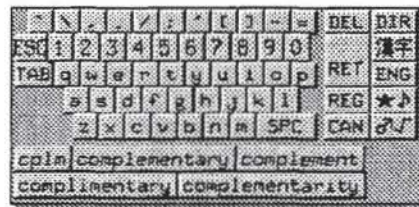

Figure 12: After specifying "cplm".

times to enter the phrase "First, we show our technique for entering." Notice that the user made no spelling errors with this method, since all the input words were taken from the dictionary.

Using Approximate String Matching

With the approximate string matching feature, even when the user does not specify the correct spelling of a word, there is a good chance of finding the desired word among the candidates. Also, the user can specify only part of the spelling to find the desired word. For example, if the user does not remember the spelling of "Mediterranean," he can specify "mdtrn" to see the list of words which are close to the pattern and then can find the right word in the list (Figure 10.)

The same technique can be used to enter a word that has a common prefix. If the user tries to enter "complementary" and specifies "comple," he still cannot find the word in the candidates in Figure 11, since there are many commonly used words that begin with "comple." Instead, the user can specify the characters that better represent the word. As shown in Figure 12, the user can obtain "complementary" by specifying "cplm," although other patterns such as "cpmt" will also work.

Entering Japanese Text

With POBox, users can enter Japanese text much more easily than RKC and handwriting recognition systems. We show the example by using "以下に本手法を用いた文章入力例を

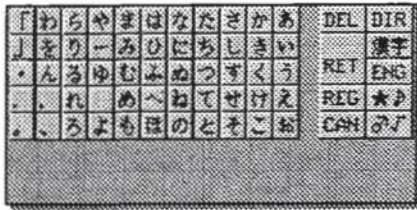

Figure 13: Initial display in Japanese input mode.

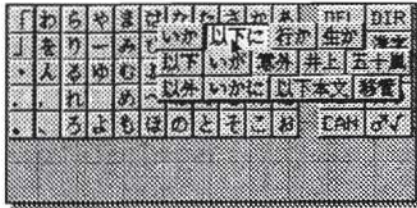

Figure 14: Selecting "以下に".

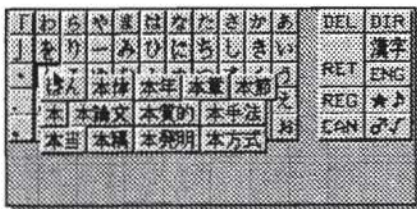

Figure 15: Before selecting "本手法".

示す² as a sample Japanese input text. Figure 13 shows the initial display of POBox in Japanese input mode. A Hiragana character table is displayed for entering pronunciations, instead of the Roman alphabet in English mode.

The pronunciation of the first word "以下に" is "いかに"(i-ka-ni), and the user can select the word by choosing "い"(i) and "か"(ka) from the Hiragana keyboard, just like in the English example. Figure 14 shows how the user can select the word "以下に" with the pull-down menu. The user can select the next word "本手法" (pronounced "hon-shuhou") after selecting its pronunciation "ほ"(ho) and "ん"(n).

In this way, the user can enter Japanese text by specifying the pronunciation of the first portion of the word and then selecting the desired word from the menu, just like specifying the spelling for English words. The user can input the phrase "以下に本手法を" in 7 penstrokes, whereas the ordinary RKC method requires at least 20 penstrokes.

DETAILS OF THE ALGORITHM Dictionaries and Word Prediction

The word dictionary is a set of 2-tuples {word, spelling/pronunciation} sorted by the term frequency of the word. The top portion of the English word dictionary is shown in Figure 16. Since "the" appears more often than any other word in the corpus, it resides at the top of the dictionary, with its spelling "THE." The phrase dictionary is a set of 3-tuples {context, word, spelling/pronunciation} sorted by the phrase

²Here, we show an example of entering text using this method

Word	Spelling/Pronunciation
the	THE
of	OF
to	TO
and	AND
...	...

Figure 16: Word dictionary.

Context	Word	Spelling/Pronunciation
of	the	THE
in	the	THE
to	the	THE
...
as well	as	AS
into	the	THE
...

Figure 17: Phrase dictionary.

frequency. Here, "context" means the word(s) that precede the input word. The top portion of the initial phrase dictionary is shown in Figure 17. Of all the phrases (lists of more than one words), "of the" occurs most often and hence appears at the top of the phrase dictionary.

Whenever possible, POBox checks the context and the characters specified by the user, and generates the list of candidate words for the next user input. First, it checks the phrase dictionary and looks for the dictionary entries whose context match the current context and whose spelling match the user input. If such entries are found, POBox puts them into the candidate list. Then it checks the word dictionary and looks for entries whose spelling match the user input. If no entry is found in both of the dictionaries, POBox tries to find more candidate words by performing approximate string matching described in the next section. After the user selects a word from the menu, the newly selected word and phrase are put at the top of the dictionaries.

A middle-sized natural language dictionary usually has 20,000 to 50,000 word entries, which occupies less than 500KB of memory without compression. With appropriate compression and indexing techniques, a word dictionary plus a phrase dictionary can easily be packed into 1MB of memory.

Approximate String Matching

Our approximate string matching algorithm is based on Baeza-Yates' "shifter algorithm"[1], with our extensions for allowing errors and handling simple wildcard characters. The shifter algorithm is also used in an approximate string matching program **agrep**[7] (an extension to **grep** on UNIX), where wildcard characters are treated differently from ours. In our algorithm, we limit the wildcard to the basic ".*" pattern in order to achieve simple and fast processing.



Figure 18: A state transition machine which accepts "ab.*ca".

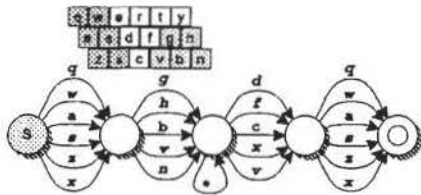

Figure 19: A state transition machine with spatial approximation

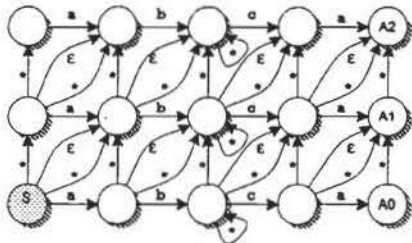

Figure 20: State transition machine which allows errors.

Figure 18 shows a nondeterministic state transition machine which accepts a regular expression "ab.*ca". In the shifter algorithm, a bit string is used to represent the status of this state machine. For example, the initial state is represented as "10000", and it becomes "11000" after accepting an "a".

The state machine can be extended to perform spatial approximate search by adding transitions by adjacent characters (Figure 19.) The state machine can also be extended to allow errors by adding extra rows of states as shown in Figure 20. A0 is the accept state with no errors, and A1 and A2 are the accept states with one and two errors, respectively. Like most spelling correctors, POBox treats character insertion, deletion and substitution as errors. Figure 21 shows the state transition by "abracadabra". After reading "ab", state A2 becomes active, showing that "ab" matches "ab.*ca" with two errors.

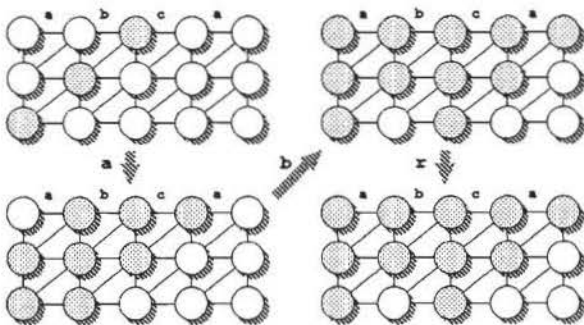

Figure 21: State transition by "abracadabra".

After reading "abra", state A1 also becomes active, showing that "abra" matches "ab.*ca" with one error.

This state transition can be calculated with simple logic and shift operations. For a short pattern with small ambiguity, POBox first creates a deterministic state transition table from the nondeterministic state transition diagram like the one shown in Figure 20, and uses the transition table instead, for faster processing. For example, the state machine in Figure 20 can be converted to a deterministic state transition table with 32 states.

EVALUATION

POBox currently runs on UNIX(X11), Windows95, Newton, Java VM, and Pilot. POBox for Pilot is the latest version, distributed to the public on the Web³ since July 1997, and downloaded by more than 10,000 people in two months. Since it is the most widely-used version of POBox, we used it for the evaluation, although it lacks the pulldown menu feature because of its limited processing power.

A set of inquiries asking the user's background and impressions of POBox was also presented on the Web page for downloading POBox, and 1,057 people answered the questions. Among the 967 people with experience in both POBox and Japanese handwriting recognition systems, 126 people (13.0%) said they feel that POBox is as efficient as handwriting recognition systems, and 796 people (82.4%) said POBox is more efficient. Among the 899 people with experience in both POBox and RKC systems, 118 people (13.2%) said they feel that POBox is as efficient as conversion-based systems, and 718 people (80.1%) said POBox is more efficient. Several people sent back comments saying that they feel POBox is the most effective pen-based Japanese input method they have ever used.

To obtain more reliable data, we asked POBox users who answered the inquiry to compare the text input time using POBox and other handwriting recognition systems⁴. Of these users, we selected approximately 300 people who seemed to have reasonable experience with both POBox and handwriting recognition systems, independent of their performance on the two systems, and 31 people agreed to perform the experiment and sent back the test results. All of them are adult male, and most of them are engineers in various Japanese companies. About half are in their thirties, three are in their forties, all of them having enough experience on both POBox and handwriting recognition systems.

We asked the participants to measure the entry time of a sample Japanese text consisting of 53 Kanji/Kana characters and 2 punctuation characters, under the following conditions:

1. writing the text on paper.
2. entering the same text using POBox.
3. entering the text using conventional RKC.
4. entering the text using the participants' favorite Kanji handwriting recognition systems on any architecture.

³<http://www.csl.sony.co.jp/person/masui/POBox/pilot.html>

⁴We offered calling cards (a value of approximately \$5) to the participants as a token incentive to perform the test seriously.

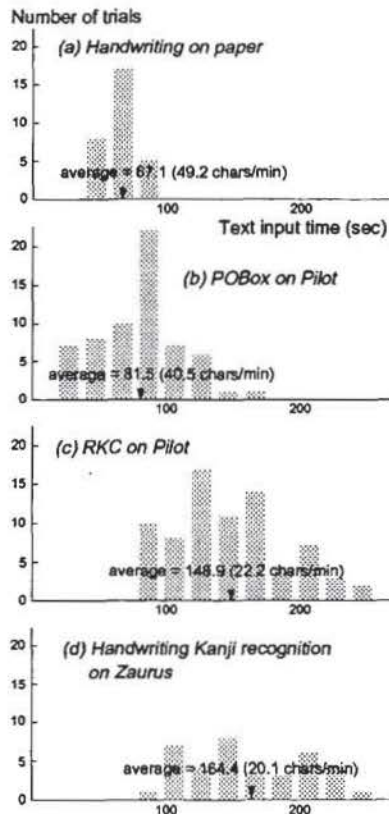

Figure 22: Distribution histograms of text input time using different methods.

The second and third tests were performed on the Pilot, which does not have a Kanji handwriting recognition system. Therefore, we asked the participants to use their favorite recognition systems, instead.

Among the 31 participants, 10 people used the same handwriting recognition system available on a Zaurus PDA⁵ (made by Sharp). Other people used various handwriting recognition systems on PCs and other PDAs, but the recognition time was longer than on the Zaurus. The summary of the test result is shown in Figure 22. Since not all participants completed all experiments for the same number of times, the area of the histogram differ among the tests.

Input Speed Comparison

Most of the participants could write the sample text on paper faster than with any of the electronic text input methods. (The average was about 50 chars/min.) Writing speed does not vary significantly between people. On the other hand, the text input speed using Zaurus' Kanji handwriting recognition system does vary considerably from person to person, the average being about 20 chars/min. This is much slower than writing on paper, because of the recognition error and

⁵Zaurus was the most popular PDA in Japan at the time this experiment was performed.

difficulty of writing on a tablet. No correlation was observed between the speed of writing on paper and the speed of entering text using handwriting recognition systems.

The average text input speed using POBox was about 40 chars/min, which is approximately twice as fast as conventional RKC or Zaurus' handwriting recognition system. While the fastest handwriting recognition times observed were shorter than the slowest POBox users, every individual tested performed better with POBox than with the handwriting recognition system.

Approximate String Matching

We have not advertised the approximate string matching feature very much on the Web page, but 448 people (43.4%) of the users noticed this feature. Of these 448 users, only 30 of them (6.7%) answered that approximate string matching was not useful for them.

DISCUSSIONS

Stochastic Analysis of the Dictionary

The total number of words in the CHI'95 CD-ROM is about 650,000, and the distribution of the frequency conforms well to Zipf's rank-frequency law. From the data, the probability of finding the desired word in the candidate menu after entering the top portion of the spelling can be calculated by summing up all the frequencies of words that appear in the menu after each penstroke. This is the case when using POBox without the prediction from context feature. The result is shown in Figure 23.

When the system shows 10 candidates after each penstroke, about 53% of the input words can be found in the menu after specifying one character, and about 92% of words can be found after three penstrokes. This means that 92% of the words can be entered with four penstrokes, while about 50% of the words in the CHI'95 CD-ROM consist of more than four letters. This result shows that the menu-based text input method of POBox is effective even without the prediction mechanism.

The same analysis for the Japanese dictionary is shown in Figure 24. Since about 50 Hiragana characters are used for

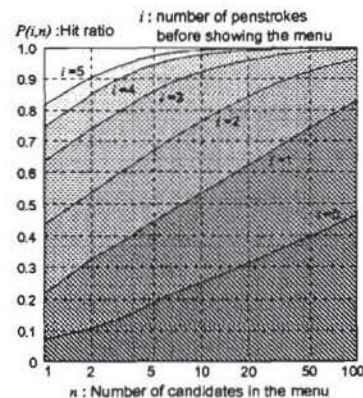

Figure 23: Probability of finding the desired word in the menu (English text).

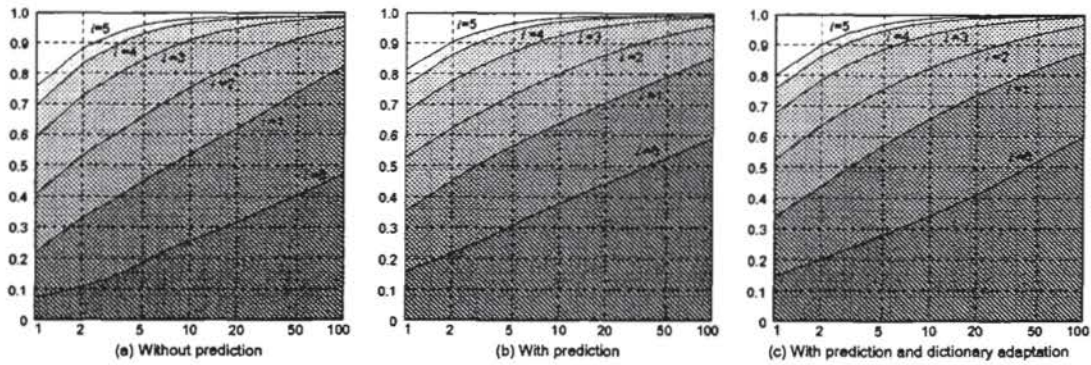

Figure 25: Probability of finding the desired word in the menu.

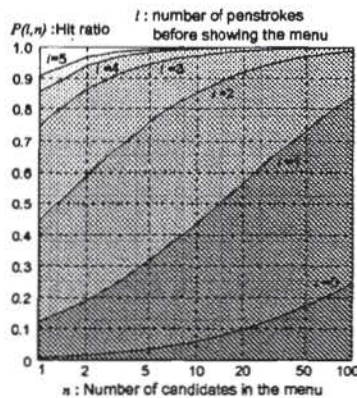

Figure 24: Probability of finding the desired word in the menu (Japanese text).

Japanese text input, most of the desired words can be found in the menu after two or three penstrokes, while more than four penstrokes are required using ordinary Kanji-conversion methods.

Dynamic Analysis

More accurate hit ratio of POBox menus can be calculated by simulating the prediction and adaptation mechanisms of POBox with real English text. Figure 25(a) shows the hit ratio calculated by using all the texts in the CHI'95 CD-ROM. The hit ratio with the prediction from context feature is shown in Figure 25(b), and the hit ratio with prediction and dictionary adaptation is shown in Figure 25(c). Prediction from context is effective for increasing the hit ratio, especially when no input is specified for selecting words ($i = 0$). In this case, POBox displays the correct word among its 10 candidates 38% of the time, whereas this number drops to 26% when prediction is not used.

Input Speed Estimation

Text input speed can also be estimated by dynamic analysis if the character input speed using the soft keyboard and the speed of menu selection is known.

From the dynamic analysis shown above, the hit ratio $P(i, n)$ of finding a word in the menus with n items after selecting

i characters is known. If it takes T_k for a user to input one character and it takes $T_s(n)$ to select an item from the menu with n items, the average total time for entering a word ($T(i, n)$) can be calculated by the following formula:

$$\begin{aligned}
 T(i, n) &= T_s(n) \\
 &+ (T_k + T_s(n))(1 - P(0, n)) \\
 &+ (T_k + T_s(n))(1 - P(1, n)) \\
 &+ \dots \\
 &= T_s(n) + \sum_{j=0}^{\infty} (T_k + T_s(n))(1 - P(j, n))
 \end{aligned}$$

If the user starts using the menu after entering at least i characters, the average total time $T(i)$ is calculated by the following formula:

$$T(i, n) = i \cdot T_k + T_s(n) + \sum_{j=i}^{\infty} (T_k + T_s(n))(1 - P(j, n))$$

We assume that $T_s(n)$ is proportional to n and T_k is a constant value, since POBox shows a menu of candidates according to the probability of the words, and the user cannot tell the ordering of the words in the menu beforehand. We calculated $T(i, n)$ using $P(i, n)$ for the two cases of slow and fast character input.

Slow Character Input: Figure 26 shows the calculated average time for entering a word where character input speed is slow and $T_s(n)$ can be estimated to be $n/10$ and T_k is the constant 1. In this case, without prediction, the minimum text input time is obtained when $i = 1$ and $n = 3$, which means using a three-entry menu after one penstroke without a menu. With prediction, the input time is minimized when $i = 0$ and $n = 3$, which means using a three-entry menu from the start. This is because frequently-used words are displayed at the top of the menu even before the user specifies characters for filtering the dictionary. The estimated average time for entering words is smaller with prediction than without prediction.

Faster Character Input: Figure 27 shows the average time for entering a word, where character input speed is faster than the previous example and $T_s(n)$ is estimated to be $n/3$. In this case, minimum input time is obtained when $i = 0$ and $n = 1$, which means predicting one word every time after entering a character.

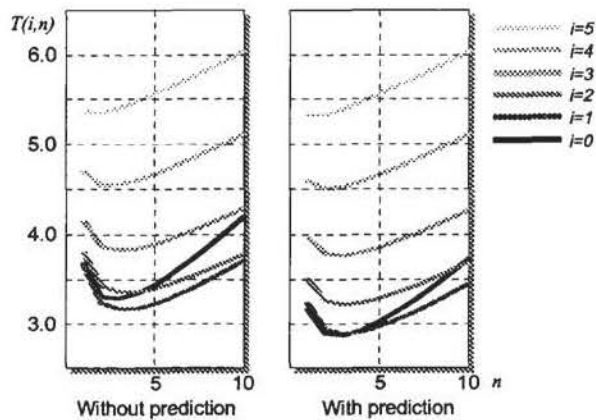

Figure 26: Text input speed estimation with slow character input. ($T_k = 1$, $T_s(n) = n/10$)

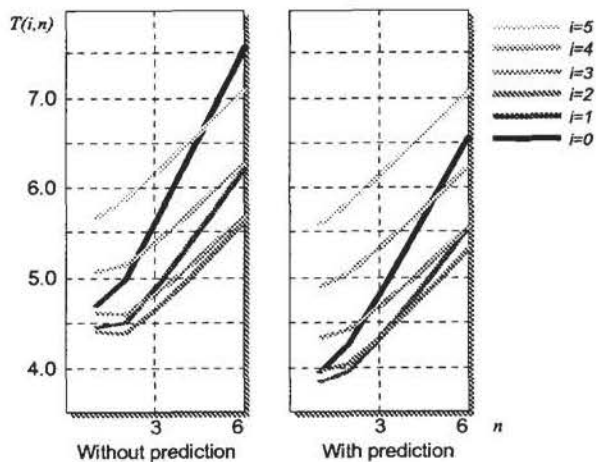

Figure 27: Text input speed estimation with faster character input. ($T_k = 1$, $T_s(n) = n/3$)

In this manner, the fastest method for entering text depends on the relation between $T_k/T_s(n)$ and $P(i, n)$. Roughly speaking, when $T_k/T_s(n)$ is very small (character input is very fast) as with a keyboard, the fastest way of entering text is entering characters without the use of menus. On the other hand, if $T_k/T_s(n)$ is very large (character input is very slow), using menus with many entries is faster. The two cases shown in Figure 26 and Figure 27 are between these extremes, and POBox supports the entire spectrum.

Related Work

Darragh's Reactive Keyboard[2] predicts the user's next key-strokes from the statistical information gathered by the user's previous actions and shows the predicted data for the selection. Unfortunately, the Reactive Keyboard is not usually useful for experienced computer users, since they can type much faster than selecting candidates from the menu. On pen-based computers, however, people cannot enter characters as fast as with keyboards, thus predictive methods like POBox and the Reactive Keyboard are useful. By integrating

existing common GUI tools with the prediction mechanism, POBox can greatly reduce the time for text input on pen-based computers, especially for Japanese and other languages where direct text input is not possible.

Greenberg[5] argued that it is convenient to put frequently used tools close at hand, and showed that this technique is useful for issuing text commands in his WORKBENCH system. POBox resembles the WORKBENCH system in that both frequently used words and recently used words always appear close at hand at the top of the candidate list for quick selection.

Fukushima et al.[3] showed that input word prediction can reduce the search space and the number of penstrokes for handwriting recognition of Japanese texts. Although they reported that their prediction system could reduce input penstrokes from 10 to 40 percent, problems with handwriting recognition still remain and the text input speed does not increase dramatically.

CONCLUSIONS

We developed a new fast text input method for pen-based computers based on dynamic query of the dictionary and word prediction from context. With our method, the speed of text input on pen-based computers greatly increases and for the first time, pen computing becomes a viable alternative to keyboard-based input methods.

ACKNOWLEDGEMENTS

We would like to thank Jun Rekimoto and Jeremy Cooperstock for giving us many valuable suggestions. We also thank many POBox users who actually used it, sent comments to us, and performed the evaluation tests.

REFERENCES

1. Baeza-Yates, R. A., and Gonnet, G. H. A new approach to text searching. *Communications of the ACM* 35, 10 (October 1992), 74-82.
2. Darragh, J. J., Witten, I. H., and James, M. L. The Reactive Keyboard: A predictive typing aid. *IEEE Computer* 23, 11 (November 1990), 41-49.
3. Fukushima, T., and Yamada, H. A predictive pen-based Japanese text input method and its evaluation. *Transactions of Information Processing Society of Japan* 37, 1 (January 1996), 23-30. in Japanese.
4. Goldberg, D., and Richardson, C. Touch-typing with a stylus. In *Proceedings of ACM INTERCHI '93 Conference on Human Factors in Computing Systems (CHI '93)* (April 1993), Addison-Wesley, pp. 80-87.
5. Greenberg, S. *The Computer User as Toolsmith*. Cambridge Series on Human-Computer Interaction. Cambridge University Press, March 1993.
6. Venolia, D., and Neiberg, F. T-Cube: A fast, self-disclosing pen-based alphabet. In *Proceedings of the ACM Conference on Human Factors in Computing Systems (CHI '94)* (April 1994), Addison-Wesley, pp. 265-270.
7. Wu, S., and Manber, U. Agrep - a fast approximate pattern-matching tool. In *Proceedings of USENIX Technical Conference* (San Francisco, CA, January 1992), pp. 153-162.

Copyright

This manual is copyrighted with all rights reserved. No portion of this manual may be copied or reproduced by any means without the prior written consent of Brady Worldwide, Inc.

While every precaution has been taken in the preparation of this document, Brady assumes no liability to any party for any loss or damage caused by errors or omissions or by statements resulting from negligence, accident, or any other cause. Brady further assumes no liability arising out of the application or use of any product or system described, herein; nor any liability for incidental or consequential damages arising from the use of this document. Brady disclaims all warranties of merchantability of fitness for a particular purpose.

Trademarks

TLS2200™ and LabelMark™/WIN are trademarks of Brady Worldwide, Inc.

Microsoft and Windows are registered trademarks of Microsoft Corporation.

Brady reserves the right to make changes without further notice to any product or system described herein to improve reliability, function, or design.

© 2000 Brady Worldwide, Inc. All Rights Reserved

Revision D, printed March 2000

Software Version 3

Brady Worldwide, Inc.
6555 West Good Hope Road
P.O. Box 2131
Milwaukee, WI 53201

Main Switchboard:	(800) 541-1686
	(414) 358-6600
FAX:	(800) 292-2289
Sales/Customer Support:	(800) 537- 8791

FCC Notice—U.S. Only

WARNING: This equipment generates, uses, and can radiate radio frequency energy. If not installed and used in accordance with the manufacturer's instructions, it may cause interference to radio communications. It has been tested and found to comply with the limits for a Class A computing device pursuant to Subpart J of Part 15 of the FCC rules, which are designed to provide reasonable protection against interference when operating in a commercial environment. Operation of this equipment in a residential area is likely to cause interference, in which case corrective measures will be at the owner's expense.

The user is cautioned that any changes or modifications not expressly approved by Brady Worldwide, Inc. could void the user's authority to operate the equipment.

This is a Class A product. In a domestic environment this product may cause radio interference in which case the user may be required to take adequate measures.

Europe

This is a Class A product. In a domestic environment this product may cause radio interference in which case the user may be required to take adequate measures.

Canada

This Class A digital apparatus meets all requirements of the Canadian Interference-Causing Equipment Regulations.

Brady Warranty

Our products are sold with the understanding that the buyer will test them in actual use and determine for him or herself their adaptability to his/her intended uses. Brady warrants to the buyer that its products are free from defects in material and workmanship, but limits its obligations under this warranty to replacement of the product shown to Brady's satisfaction to have been defective at the time Brady sold it. This warranty does not extend to any persons obtaining the product from the buyer.

THIS WARRANTY IS IN LIEU OF ANY OTHER WARRANTY, EXPRESS OR IMPLIED INCLUDING, BUT NOT LIMITED TO ANY IMPLIED WARRANTY OF MERCHANTABILITY OR FITNESS FOR A PARTICULAR PURPOSE, AND OF ANY OTHER OBLIGATIONS OR LIABILITY ON BRADY'S PART. UNDER NO CIRCUMSTANCES WILL BRADY BE LIABLE FOR ANY LOSS, DAMAGE, EXPENSE OR CONSEQUENTIAL DAMAGES OF ANY KIND ARISING IN CONNECTION WITH THE USE, OR INABILITY TO USE, BRADY'S PRODUCTS.

YOU SHOULD CAREFULLY READ THE FOLLOWING TERMS & CONDITIONS OF THIS LICENSE AGREEMENT. IF YOU DO NOT AGREE WITH THESE TERMS & CONDITIONS, PLEASE PROMPTLY RETURN THIS PACKAGE FOR A FULL REFUND.

License Agreement

Brady USA, Inc. (hereafter "BRADY") hereby grants you a non-exclusive, non-transferable license to use the software and accompanying documentation according to the following terms:

1. **LICENSE RESTRICTIONS:** You may not: 1) transmit the software over a network without an additional license; 2) modify, adapt, translate, reverse engineer, decompile, disassemble, create derivative works based on, or copy (except for one back-up copy) the software or the accompanying documentation; 3) rent, transfer, or grant any rights in the software or accompanying documentation without prior, express written consent of BRADY; or 4) remove any proprietary notices, labels, or marks on the software and accompanying documentation.
2. **NATURE OF THIS AGREEMENT:** This license is not a sale. Title and copyrights to the software, accompanying documentation, and any copy made by you remains the property of BRADY. Unauthorized copying of the software or the accompanying documentation, or failure to comply with the above restrictions, shall automatically terminate this license without further notice, and terminate your rights to use the software, and BRADY shall, in addition to its other legal remedies, be entitled to its reasonable attorney fees.
3. **LIMITED WARRANTY:** BRADY warrants that, for a period of one hundred and eighty (180) days from the date of delivery to you as evidenced by a copy of your receipt, the software, as furnished, under normal use, will perform without significant errors that make it unusable. BRADY's entire liability and your exclusive remedy under this warranty (which is subject to you returning the software to BRADY) will be, at the option of BRADY, to attempt to correct or help you around errors, to replace the software with functionally equivalent software or diskettes, or to refund the license fee of the software and terminate this agreement.

EXCEPT FOR THE ABOVE EXPRESS LIMITED WARRANTY, BRADY MAKES AND YOU RECEIVE NO WARRANTIES, EXPRESS, IMPLIED, STATUTORY OR IN ANY COMMUNICATION WITH YOU, AND BRADY SPECIFICALLY DISCLAIMS ANY IMPLIED WARRANTY OF THE WARRANT THAT THE OPERATION OF THE PROGRAM WILL BE UNINTERRUPTED OR ERROR FREE.

Some states do not allow the exclusion of implied warranties so the above exclusion may not apply to you. This warranty gives you specific legal rights. You may also have other rights which vary from state to state.

4. **LIMITATION OF LIABILITY:** IN NO EVENT WILL BRADY BE LIABLE FOR ANY DAMAGES, INCLUDING LOSS OF DATA, LOST PROFITS, COST OF COVER OR OTHER SPECIAL, INCIDENTAL, CONSEQUENTIAL OR INDIRECT DAMAGES ARISING FROM THE USE OF THE PROGRAM OR ACCOMPANYING DOCUMENTATION, HOWEVER CAUSED AND ON ANY THEORY OF LIABILITY. THIS LIMITATION WILL APPLY EVEN IF BRADY HAS BEEN ADVISED OF THE POSSIBILITY OF SUCH DAMAGE. YOU ACKNOWLEDGE THAT THE LICENSE FEE REFLECTS THIS ALLOCATION OF RISK.

Some states do not allow the limitation or exclusion of liability for incidental, or consequential damages, so the above limitation may not apply to you.

5. **General:** If the product is acquired under the terms of a 1) GSA contract - use, reproduction or disclosure is subject to the restrictions set forth in the applicable ADP Schedule contract; 2) DOD contract - use, duplication or disclosure by the Government is subject to restrictions set forth in subparagraph (c)(1)(ii) of 252.277-7013; 3) Civilian agency contract - use, reproduction, or disclosure is subject to 52.277-19(a) through (d) and restrictions set forth in this Agreement. Unpublished rights reserved under the copyright laws of the United States.

This Agreement shall be governed by, and interpreted under, the laws of the state of Wisconsin. This Agreement is the entire agreement between the parties and supersedes any other communications or advertising with respect to the software and accompanying documentation. If any provision of the Agreement is held invalid, the remainder of this Agreement shall continue in full force and effect.

Technical Support

Choose one of the following options to contact TLS2200™ system support provided by Brady Worldwide, Inc.:

1. To speak with a Technical Support Representative, call (800) 643-8766; Monday - Friday 7:00 a.m. - 7:00 p.m. (CST).
2. FAX your inquiry to (414) 358-6767.
3. Contact Brady's Technical Support Team on-line at: tech_support@bradycorp.com.

Table of Contents

Introduction	1
Unpacking Your TLS2200™ Thermal Labeling System	1
Saving Your Packaging	1
TLS2200™ Thermal Labeling System Specifications	2
Physical and Environmental Characteristics	2
Certification	2
Knowing Your Software Version Number	3
Quick Start Guide	4
Summary of Steps.....	4
Working with Screens and Menus	13
The Text Editor Screen	13
The Setup Menu.....	13
Setup Menu Options	14
Setup Menu Tree.....	20
Creating Legends	21
Using the <Enter> Key When Composing a Legend.....	21
Default Font Size.....	21
Changing the Font Size	22
TLS2200™ Printer Fonts.....	22
Clearing the Legend.....	24
Saving and Recalling a Legend.....	24
Function Keys	25
Printing Your Labels	26
Adjusting Burn Temperature.....	26
Setting Peel Time	26
Printing Larger Labels	26
Reloading Marker Rolls and Ribbons	27
Advanced Features	28
Serialized Labels.....	28
Legend Lists.....	30
Continuous Printing—Terminal Block Labels	37
Continuous Printing—Banners.....	38
Default Font Size.....	39
Fixed Length Banners.....	39
Barcode Labels	39
Tutorial Guide.....	42
T1: Creating a One-Line Legend, Component Marker	42
T2: Creating a Component Label Utilizing Multiple Font Sizes	43
T3: Creating a Wiremarker	44
T4: Creating Serialized Wiremarkers.....	45

T5: Creating a Label with Rotated Text, Printing Multiple Copies	46
T6: Creating a Barcode Label	48
T7: Creating a Serialized Barcode Label.....	50
T8: Creating a Terminal Block Label	52
T9: Creating a Patch Panel Label	54
T10: Creating a Continuous Label	56
T11: Creating a Banner Label of Fixed Length.....	57
T12: Creating a Legend List, Component Markers	58
T13: Creating a Legend List Utilizing Multiple Font Sizes and Rotations.	60
T14: Creating a Legend List, Wiremarkers, Printing Multiple Copies	62
T15: Creating and Recalling a Legend List, Barcode Labels.....	64
T16: Creating a Legend List, Recalling and Editing a Legend.....	66
T17: Creating a Legend List, Banner Legends.....	68
Maintenance.....	70
Cleaning the Drive Roller and Cutter.....	70
Cleaning the Print Head	70
Accessory Parts List.....	70
Appendix 1: Troubleshooting and Error Message Guide	71
Troubleshooting Guide	71
Error Messages	73
Appendix 2: Glossary of Terms	78
Appendix 3: Using the TLS2200™ Program Installer	79
System Requirements	79
Installing the TLS2200™ Program Installer from the Internet	79
Installing the TLS2200™ Program Installer from Disk	80
Connecting the TLS2200™ Printer to a PC	82
Running the TLS2200™ Program Installer.....	83
Future Installations	83
Appendix 4: Direct Printing from LabelMark/Win.....	85

Introduction

Small in size, big in performance! Since the invention of thermal transfer technology, the idea has remained unchanged—bigger has always been better. Until now. Brady introduces the TLS2200™ Thermal Labeling System. This hand-held thermal transfer printer is the new leader in the Brady line of quality performance printers. Weighing in at just 1.32 kg (2.75 lbs.), it is the only thermal-transfer barcode/label printer that you can hold in just one hand.

Never before has there been a printer quite like the TLS2200 printer. It is so easy—simply choose the type of labels you want to print and load them in. The TLS2200 printer takes care of the rest. Thanks to its innovative smart-cell technology, the TLS2200 printer recognizes the label you are using and automatically adjusts itself, saving you a significant amount of setup time. As you will see, the TLS2200 printer is the first hand-held thermal transfer printer that is not only portable, quick, and easy to use, but uniquely intelligent as well. We are sure you will find it to be an extremely versatile and durable tool, useful for a great number of label-making needs.

Unpacking Your TLS2200™ Thermal Labeling System

Before you begin setting up the printer, verify you have received the following items in your packaging:

- TLS2200 Thermal Labeling System
- Hard Side Carrying Case
- Battery Pack
- Battery Charger
- Warranty Card
- Cleaning Card
- Font Size/Ribbon Cross Reference Guide Card
- Quick Start Reference Card
- Communications Cable
- User's Manual
- R6210 Ribbon
- Sample Label Roll (PTL-19-423)

Saving Your Packaging

The packaging surrounding your TLS2200 printer should be saved in the event of any future shipments of the printer and accessories.



WARNING: Never ship the TLS2200 printer without first removing the rechargeable battery pack from the printer **and** disengaging the print head.

If shipping both the printer and battery pack, remove the battery pack from the printer and place the items in the original shipping material before transporting.

TLS2200™ Thermal Labeling System Specifications

The TLS2200 printer has the following specifications:

- Weight 1.32 kg (2.75 lbs.)
- Thermal Transfer Print Mechanism 8 dots/mm (203 dpi)
- Optical Registration System for Precise Print Registration
- Elastomeric Keypad
- 2-Line by 16-Character Liquid Crystal Display
- Custom True Type Font (Arial)
- Labels up to 50.8 mm (2") Wide
- Print Width – 46 mm (1.81")
- Print Length – Over 1424 mm (56")
- Adjustable for six Different Liner Widths
- Prints 500 Labels Between Battery Charges
- Six Month Warranty

Physical and Environmental Characteristics

The TLS2200 printer has the following physical and environmental characteristics:

PHYSICAL	Metric Units	U.S. Units
Dimensions	305 x 95 x 114 mm.	12 x 3.75 x 4.5 in.
Weight (with battery pack)	1.32 kg	2.75 lb.

ENVIRONMENTAL	Operation	Storage
Temperature*	4E to 40EC (40E to 105EF)	-18E to 60EC (0E to 140EF)
Relative Humidity	20% to 95% (non-condensing)	10% to 80% (non-condensing)

*Exposing the TLS2200 printer to direct sunlight is not recommended.

Certification

The TLS2200 printer has the following certifications:

- FCC Class A Approved
- UL/CUL-listed Battery Charger

Knowing Your Software Version Number

The software in your TLS2200™ printer can be updated through the use of the TLS2200 Program Installer. To determine the version number of the software currently loaded in your TLS2200 printer, watch the LCD screen as you turn the unit on. You will see one of the following welcome screens:

***** TLS2200 *****
Please Wait

This is the welcome screen for a TLS2200 printer with version 1.0 software.

TLS2200 V2.0
Please Wait

This is the welcome screen for a TLS2200 printer with version 2.0 software.

TLS2200 V3.0
Please Wait

This is the welcome screen for a TLS2200 printer with version 3.0 software.



Note: For more information about updating your TLS2200 software, refer to Appendix 3: Using the TLS2200™ Program Installer.

Quick Start Guide

This section guides you through the process of creating a label. Read the rest of this manual for detailed information on each of these steps, as well as other functions not listed here.



Note: It is suggested that you read *Appendix 2: Glossary of Terms* before you read this guide. This appendix acquaints you with the terms found in this manual that are used within the specific context of the TLS2200™ printer.

Summary of Steps

Following is a summary of the steps needed to create a label. A complete description of each step follows later in this section.

Step	Purpose of Step	Page
1	To charge the battery	4
2	To install the battery.	5
3	To turn the power on.	5
4	To select the marker and ribbon.	6
5	To install the ribbon cartridge.	7
6	To remove the marker roll.	8
7	To install the marker roll.	8
8	To type text.	8
9	To edit text.	10
10	To print the label.	12

Step 1. Charge the Battery

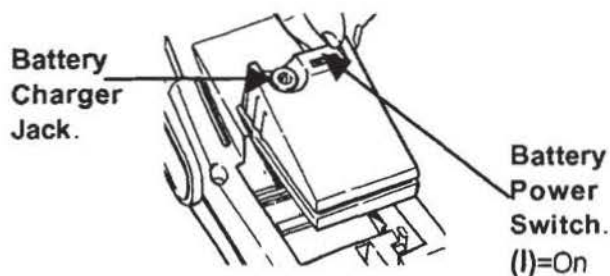

Note: The battery pack is shipped in an uncharged condition. Charge the battery for a minimum of five hours before operating the printer solely on battery power.

You can charge the battery pack while the battery power switch is turned *on* or *off*. The

battery pack charges as long as the charger is plugged in. Brady recommends that once the battery pack is fully charged, you should unplug the charger and operate the printer solely on battery power.

If the battery pack is completely discharged, connecting the charger does not provide enough power to run the printer. Recharge the battery pack before continued use.



WARNING: Disposal of the Battery Pack

The NiCad battery pack contains cadmium, a toxic element. The battery pack is considered hazardous toxic waste and must not be thrown away in the home or office garbage. Once the useful life of the battery is ended (one to three years), contact your local authorities for information regarding its proper disposal or recycling options.

Step 2. Install the Battery

1. Turn the battery power switch to the *off* (O) position.
2. Slide the battery release lever to the unlock position. (slide to left)
3. Drop the battery in as shown and slide forward.
4. Slide the battery release lever to the lock position. (slide to right)

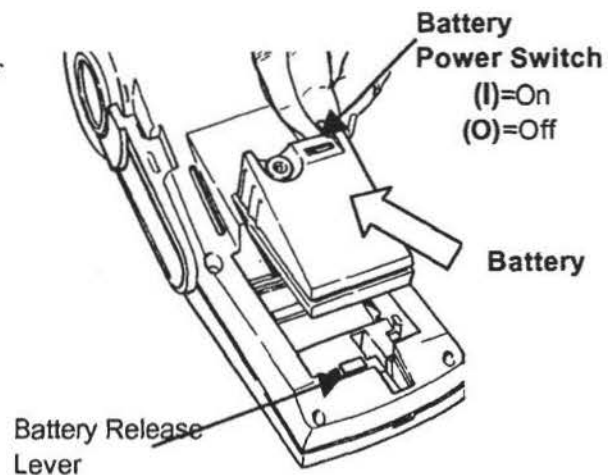

Step 3. Turn the Power On

Turn battery power switch to the *on* (I) position.

Step 4. Select Your Marker and Ribbon

Use the following chart to select the appropriate marker and ribbon for your task:

B #'s	Material	RIBBON SERIES			
		R4310	R4410 (Colors)	R6010	*R6210
B-109	Tag	●			
B-321	Polyolefin				●
B-342	Polyolefin	●			
B-351	Vinyl				●
B-400	Vinyl Cloth	●			
B-412	Polypropylene	△			●
B-422	Polyester		● UL/CSA	● UL/CSA	△
B-423	Polyester		● UL/CSA	● UL/CSA	△
B-424	Paper	●			
B-426	Polyimide	●			
B-427	Vinyl	●			●
B-428	Polyester	● UL/CSA			
B-430	Polyester		● UL/CSA	● UL/CSA	△
B-435	Polyester		● UL/CSA	● UL/CSA	
B-437	Tedlar®	●			△
B-439	Vinyl		●		△
B-457	Polyimide		● UL	● UL	
B-459	Polyester		● UL/CSA	● UL/CSA	
B-473	Polyester		● UL/CSA	● UL/CSA	△
B-477	Polyimide		● UL	● UL	△
B-483	Polyester		● UL/CSA	● UL/CSA	△
B-499	Nylon Cloth	● UL/CSA			△
B-642	Tedlar®	●			△

Tedlar® is a registered trademark of Dupont

Key:

Code	Description
●	Recommended ribbon for use with respective material.
△	Acceptable ribbon for use with respective material.
UL	This material is UL recognized with its respective ribbon.
CSA	This material is CSA approved with its respective ribbon.

UL/CSA	This material is UL & CSA approved with its respective ribbon.
*	R6210 ribbon included with printer.

Step 5. Install the Ribbon Cartridge

1. Remove cartridge from the bag. Avoid touching or creasing the ribbon.
2. Remove any ribbon slack by rotating take-up spool end counter-clockwise.
3. Slide ribbon cartridge firmly into printer. (Locking lever must be in unlock position – see below.)
4. Push the locking lever towards the back of the printer to close the print head and lock the ribbon cartridge in place.

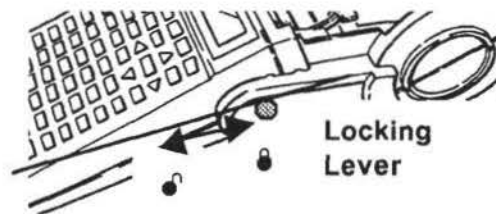
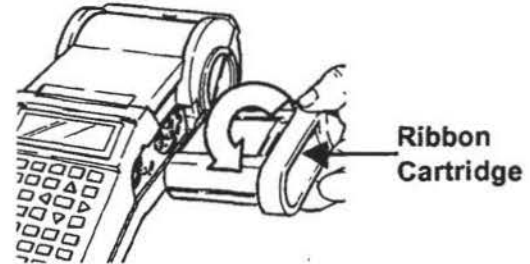

Step 6. Remove a Marker Roll

1. Cut off printed labels with the cutter lever.
2. Open the roll door.
3. Slide the locking lever to the unlock position.
4. Back the markers out of the material guide slots.
5. Pull the marker roll out of its cradle.

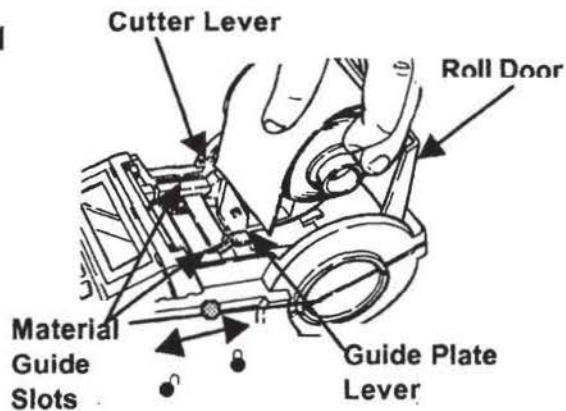

Step 7. Install a Marker Roll

1. Slide the locking lever to the lock position.
2. Turn the power switch on.
3. Open the roll door.
4. Pressing the guide plate lever down, slide and snap it into a notch that matches your marker roll width.
5. Making sure labels unwind from the top, snap the marker roll firmly into cradle.
6. Press **<Enter>** to clear the "ERROR No Label Present" message.
7. Feed leading edge of marker roll through the guide slots.
8. Press **<Feed>**. (Continue to manually push marker roll edge until it catches.)
9. Close the roll door.

Step 8. Type Text

Use the following guidelines when typing text:

Text Type	Guidelines
Alphabetic letters	Type lower-case letters (a-z) by pressing the appropriate keys. Press the <Space> key to add a space between words. Type an upper-case letter by holding down the <Shift> key while typing the letter. To type many upper-case letters in a row, turn the caps lock feature on by pressing the <Func> + <Cap Lock> keys.
Numbers	Type numbers (0-9) by pressing the desired keys.
Secondary characters	A yellow secondary character appears on the upper-right of each text key. Type one by first pressing the <Func> key, then press the desired secondary character key. For all key combinations you must press the first key first.

	Then, while still holding it down, press the second key.
Accented Characters	To place an accent mark over a vowel, type the mark first followed by the letter itself. (Note: The tilde (~) is to be used with the letters A,a or N,n only.)

The LCD displays two lines of text with 16 characters on each line. The first line always displays the **status bar**, which includes font and character positioning information (see below).

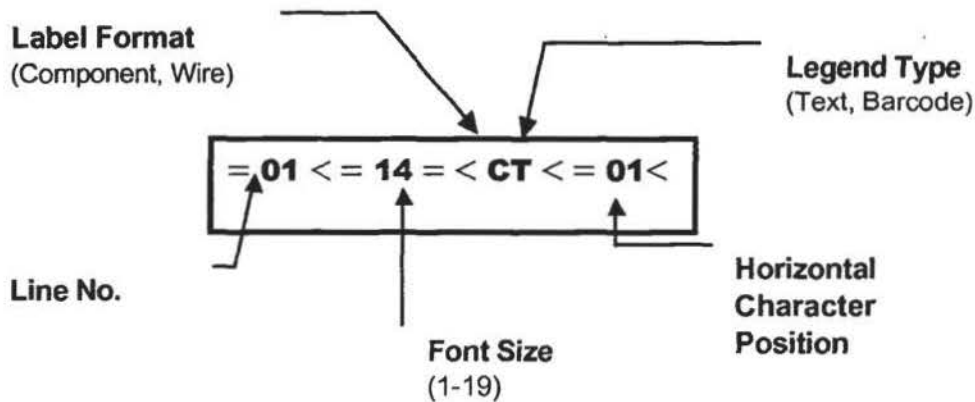

As you type characters, they appear on the liquid crystal display (LCD) at the cursor's position. Depending on the installed marker size and font size selected, you can have up to 23 lines on a single label and 50 characters on a single line. The cursor marks your current typing or editing position.

If you are entering more than 16 characters on a line, you can not see the entire label until it is printed. The arrow keys allow you to move the cursor around the LCD. As the cursor moves beyond the 16th character, the screen scrolls to display the remaining text for the label line:

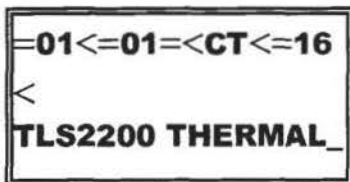

The status bar indicates the cursor is located at the 16th character position.

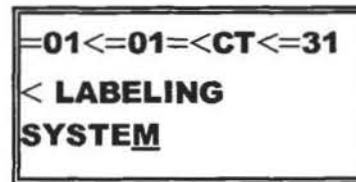

As you continue to enter text, the screen scrolls to allow the entry of the remaining text (underlined *M* is at cursor position 31).

Step 9. Edit Text

Changing Font Sizes

At any time during the text entry or editing process, you can change the font size for the label line displayed on the text editor screen. This can be done on a line-by-line basis only. To change the font size for a given line, simply press **<Shift> + <>>** or **<Shift> + <?>** respectively to increase or decrease the font size.

Cursor and Editing Keys

Use the following keys to edit your legend:



For key combinations (for example, Shift + =) you must press the first key first. Then, **while still holding it down**, press the second key.

Keys	Description
Enter	<ul style="list-style-type: none">• Activates a screen selection.• When composing a legend, inserts a non-visible end-of-line character and moves the cursor down to the next line.• Clears system messages from display.
<	Moves the cursor one character to the right. If at the rightmost position on the display, the display is scrolled one character to the left and the cursor remains at the rightmost position.
=	Moves the cursor one character to the left. If at the leftmost position on the display, the display is scrolled one character to the right and the cursor remains at the leftmost position.
>	Displays the previous line of text (if any).
?	Displays the next line of text (if any).
Shift + <	Skips to the beginning of the next word.
Shift + =	Skips to the beginning of the previous word.
Delete	<ul style="list-style-type: none">• While in text editor, deletes the character at the cursor position.• Backs out one level in the Setup Menu tree.• Terminates the printing of markers.
Shift + Delete	Backspaces as it deletes characters. If cursor is at the first character position on a line, the carriage return is deleted and any text on the line is appended to the text on the previous line.
Legend Clear	Clears all characters on the current legend line.
Shift + Legend Clear	Clears all characters on the legend.
Shift + Form Clear	Deletes all characters and lines on the legend, and resets the font size to the default value.

Keys	Description
Cap Lock	Toggles between uppercase and lowercase characters. Note: Current Cap Lock status is retained when unit is turned off.
Space Bar	Moves the cursor one position to the right. Inserts a space at the current cursor position.

Step 10. Print Labels

To print:

- the contents of your legend, simply press the **<Print>** key.
- multiple copies of your legend, press **<Func> + <Multi Print>**. The screen prompts for the “No. of Copies?”. Enter a number from 1-250 and press **<Enter>**.



Note: Press the **<Feed>** key if you want to feed one marker without printing.

When a label has printed out use the built-in cutter to remove it. Use the external lever to cut between labels.



WARNING: *Never use the cutter with BradySleeve label rolls!* The printer always advances the last printed sleeve to the appropriate position to allow tear-off at the perforation.

Working with Screens and Menus

The Text Editor Screen

Each time the printer is turned on, an initialization routine is performed, then the Text Editor screen appears. This screen is the *home base* of any processing you perform with the TLS2200™ printer. To change any of the parameters previously defined, you must access the software features of the printer by calling up the Setup Menu from the Text Editor screen. *For more information on setting the Setup Menu options, refer to the section titled The Setup Menu on page 13.*



WARNING: To ensure that text is not deleted, always set the rotation value *before* entering your legend.

After setting the label parameters, you can begin entering the text of your legend.

As previously mentioned, the LCD displays a maximum of one line of text and 16 characters on the screen at any one time. If a line consists of more than 16 characters, the LCD automatically shifts to the right to allow you to enter and view additional characters. Characters can be entered on the text editor screen in insert mode only.

The Setup Menu

The Setup Menu allows you to set and adjust label formatting or printing defaults, and specify the language in which your prompts and menus should appear. You can access any of the Setup Menu functions by following the steps below:

1. Press the **<Func>** + **<Setup>** keys to access the Setup menu.
The Setup Menu appears on the LCD.
2. Use the **<>>** and **<?>** keys to move through the menu choices. The cursor indicates the currently selected option.



Note: A downward pointing arrow on the right side of the LCD indicates there are more selections available below the currently highlighted choice.

An upward pointing arrow indicates there are more selections available above the currently highlighted choice. Up and down arrows appearing simultaneously indicate there are more selections available both above and below the currently highlighted choice.

3. Press the **<Enter>** key to access the sub-menu choices.
4. Use the **<>>** and **<?>** keys to move through the sub-menu choices. The cursor indicates the currently selected option. Press **<Enter>** to select a sub-menu.

- Use the <>> and <?> keys to select the desired menu setting, then press <Enter> to save your change. To exit without saving the change press either the <Exit> key (sends you back to the text editor screen) or the <Delete> key (backs you out one level in the menu tree).

Setup Menu Options

The Setup Menu contains seven sub-menu options for formatting and printing your labels and setting your language preference for the menus and prompts. Many of these options provide you with ways to customize the formatting of your labels. *Refer to the Setup Menu Tree section on page 20.*

Printer

The Printer Menu contains the following user options:

Option	Description
Top Margin Adj.	Adjusts first vertical print position from top of label. Values range from -0.625 mm (-0.0246 in) to +1.375 mm (0.05412 in).
Left Margin Adj.	Adjusts first horizontal print position from left edge of label. Values range from -0.625 mm (-0.0246 in) to +1.375 mm (0.05412 in).
Cut Feed Adj.	Adjusts vertical cut position between labels. Values range from -1 mm (-0.03936 in) to +1 mm (0.03936 in). The <>> and <?> keys increase/decrease value by 0.125 mm increments (1 dot).
Peel Time	Determines how long (in seconds) a label remains in peel position before moving back to cut position. Ranges from 2 to 9 seconds. Default = 5 sec. Note: Peel time option is not supported for BradySleeve and PermaSleeve marker parts.
Burn Temp	Determines the print density on the label. Setting ranges from -5 (lightest) to +5 (darkest). Default = 0
Clean Printer	Performs printer cleaning routine. Use this option with the cleaning card shipped with the unit.

Barcode

The Barcode Menu contains the following user options:

Option	Description
Bar Height	Sets the height of the Code 39 barcode. Setting ranges from 1 mm (0.03937 in) to 26 mm (1.02362 in). Default = 1 mm. Narrow bar width = 2 dots (.25 mm). Barcode Ratio = 2 to 1

Option	Description
Human Readable	Determines whether the barcode is printed along with human readable text. Toggles between on and off. Font size ranges from 2 (5 point) to 9 (14 point). Default = off.

Continuous

The Continuous Menu contains the following user options:

Option	Description
Terminal Block	Adjusts the terminal block repeat value. Setting ranges from 5 mm (0.19685 in) to 46 mm (1.81102 in). <> and <?> keys increase/decrease value by 0.125 mm increments (1 dot). <Shift> + <> and <Shift> + <?> increase/ decrease value by 1mm increments (8 dots).
Banner	Sets the orientation of the legend text on the banner. Toggles between vertical and horizontal.
Fixed Length	Adjusts the maximum length of the banner. Setting ranges from 32 mm (1.02362 in) to 305 mm (12.28346 in). <> and <?> keys increase/decrease value by 13 mm (.51 in) increments. <Shift> + <> and <Shift> + <?> increase/ decrease value by 26 mm (1.02 in) increments.

Style

The Style Menu contains the following user options:

Option	Description
Rotation	<p>Sets the rotation in one of four orientations. 0E, 90E, 180E, and 270E. Default orientation is dependent on the marker roll loaded in the unit.</p> <p>Always select the rotation value <i>before</i> entering the text for your label. A change to the rotation value causes the following to occur:</p> <ul style="list-style-type: none">• All characters and lines on a legend are deleted.• The cursor moves to the first character position on line one.• The font is set to the default size for the marker. <p>Note: Rotation option is not supported for BradySleeve, PermaSleeve, and pre-printed marker parts (defaults to 0E).</p>
H Justify	Sets the horizontal justification of the legend. Options are: Left, Center, and Right. The marker roll loaded in the unit determines the default setting.
V Justify	Sets the vertical justification of the legend. Options are: Top, Center, and Bottom. The marker roll loaded in the unit determines the default setting.

Option	Description
Format	<p>Sets the label format. Options are: Component or Wire. Default = component.</p> <ul style="list-style-type: none">• The component label format is designed to print all of the lines of a legend one time before advancing to the next marker.• The wire format is designed to automatically repeat the text of a legend down the length of a marker as many times as possible, considering the number of lines available in the marker.

Serial

The Serial Menu contains the following user options:

Option	Description
Standard	Defaults serial number scheme to decimal (0-9) or alpha (A-Z, a-z) based on character type entered.
Octal	Defaults serial number scheme to octal (Base 8). 0-7 numeric serialization.

Language

The Language Menu contains the following user options:

Option	Description
English	All menu options appear in English.
Português	All menu options appear in Portuguese.
Deutsch	All menu options appear in German.
Español	All menu options appear in Spanish.
Italiano	All menu options appear in Italian.
Français	All menu options appear in French.
Nederlands	All menu options appear in Dutch.

Units

The Units Menu allows you to set the unit of measure for the following Setup Menu options (Top Margin Adj., Left Margin Adj., Cut Feed Adj., Bar Height, Terminal Block, and Fixed Length):

Option	Description
Inches	Sets the units of measure to inches.
Metric	Sets the units of measure to millimeters.

Peripheral Mode

Peripheral Mode is a new option accessible one of two different ways. It is available on the TLS2200 Setup Menu, or you can use the <Func>+<Exit> key combination from the text entry screen. This option allows you to use the TLS2200 printer along with Brady's LabelMark™/WINV1.2 or greater software to print labels that are created and stored on your PC.

Once the TLS2200 is in Peripheral Mode, pressing any key will return it to its normal operating mode



Note: Refer to page 85 for more information about using LabelMark™/WIN.



Setup Menu Tree

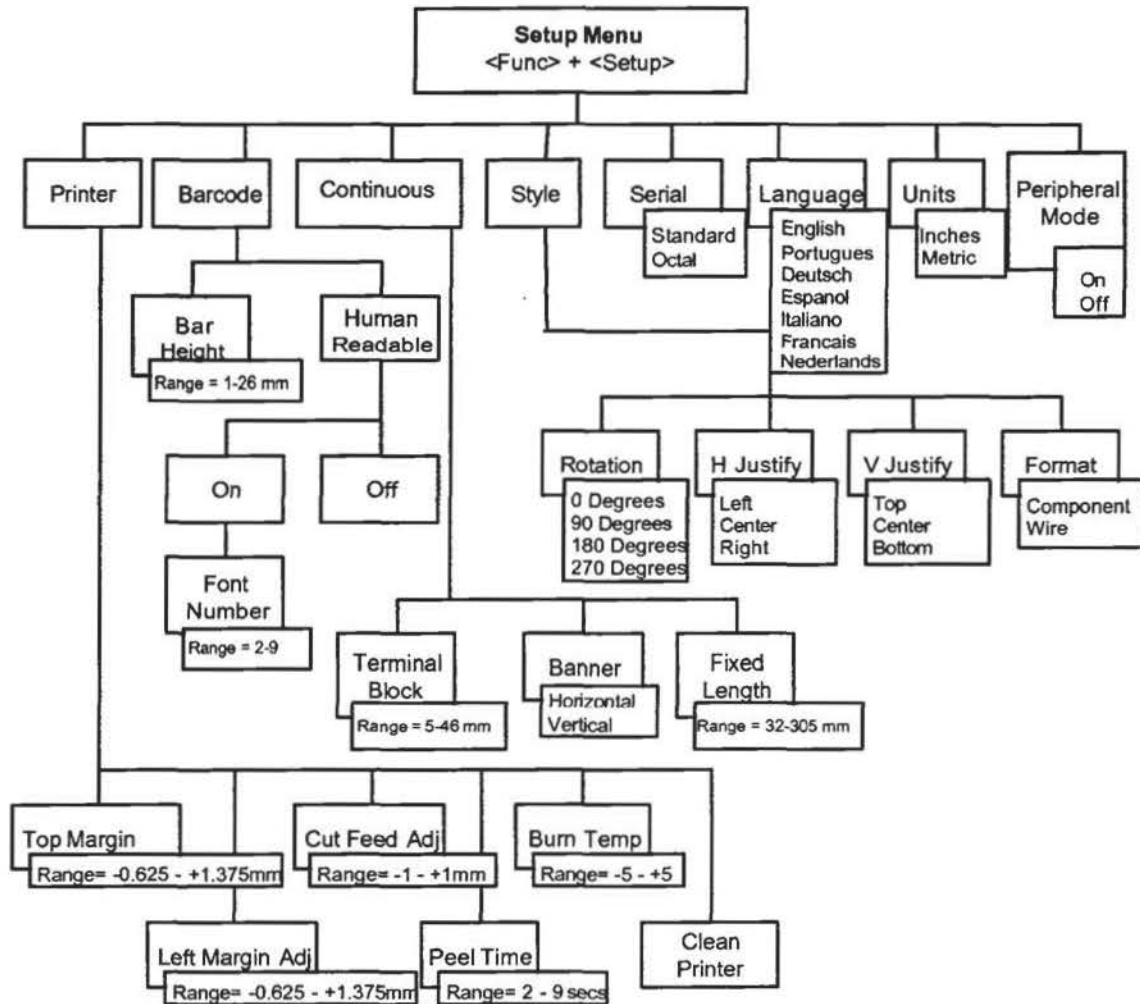

To use the menu:

- Press the <> and <?> keys to move through the menu choices and to increase/decrease values within the range.
- Press the <Shift> + <> and <Shift> + <?> keys to increase/decrease values within the range by larger steps.
- Press <Enter> to select and save menu option choices.
- Press <Exit/Delete> to exit a menu without saving changes.

Creating Legends

Using the <Enter> Key When Composing a Legend

It is not necessary to press the <Enter> key after entering the last line of text in your legend. Pressing the <Enter> key instructs the printer to reserve space for a new line of text (notice the cursor advances to the next line). Even if characters are not entered on this new line, the printer assumes the blank line is valid. As a result, markers are printed with the blank line, which leads to uncentered legends.

When the <Enter> key is pressed at the end of a line, a non-visible end-of-line character is inserted at the cursor. Characters entered after the cursor fall to the next line. This end-of-line character can be deleted by positioning the cursor over the first character position on the following line and pressing the <Shift> + <Delete> keys. This deletes the carriage return, moves up the text located on the second line, and appends the text on the first line. Any remaining lines of text also move up one line.



Note: The <Shift> + <Delete> command deletes the carriage return and appends text to the previous line only if *all* characters on the current line fit on the previous line. If the text can not fit, the carriage return is not deleted and all text remains on the current line.

Default Font Size

The TLS2200™ printer allows you to choose the font size for each individual line of text on your label (one size per line). The font size is always displayed on the status bar located on the first line of the LCD.

When a marker roll is loaded and the unit is turned on, the TLS2200 printer reads the marker size information stored in the smart-cell on the marker roll core. This information is used to automatically set an initial font size for your label. The method used to set this default is intended to help approximate an optimal starting point for sizing your text. It is as follows:

Marker Width	Default Font Size
< 12.7 mm (0.5 in.)	Largest size that allows four characters to fit on a label line
≥ 12.7 mm (0.5 in.)	Largest size that allows eight characters to fit on a label line



Note: For continuous printed labels (banners), the default font size is the largest font that prints on the selected marker width in horizontal orientation.

Once the font is set for a label line, the size remains the same for any new lines that follow

(example, font size set at 8 for line one, press **<Enter>** to add line two, font size remains at size 8). The font size remains at the size you choose until you decide to change it.

Changing the Font Size

At any time during the text entry or editing process, you can change the font size for the label line displayed on the text editor screen. This can be done on a line-by-line basis only. To change the font size for a given line, simply press **<Shift> + <=>** or **<Shift> + <?>** respectively to increase or decrease the font size.

Selectable font sizes range from 1 (4 point) to 19 (72 point). The maximum font size selectable for a particular label line depends on several factors including marker size, number of characters of text entered on the label line, number of lines of text entered on the label, and the font sizes chosen for the other label lines.

If at any time you attempt to enter too many characters on a label line, the message "Reduce Type Size" flashes on the display. To allow more characters to fit on the line, press **<Shift> + <?>** to decrease the font size.

Text already entered on a line can be switched from *text* to *barcode* mode and vice versa. If the size of the barcode, or text being switched to, does not fit on the marker, you encounter the message "Reduce Type Size" when you attempt to print the label. You must scroll to the line where the switch was made, reduce the size of the font (if text) or bar height (if a barcode), and print again.

If you press the **<Enter>** key and it no longer moves the cursor down to another line, you have attempted to enter more lines on the label than can fit. To add more lines, press **<Shift> + <?>** to decrease the font size of the existing lines.

TLS2200™ Printer Fonts

The following fonts are available on the TLS2200 printer:

FONT NUMBER	POINT SIZE	PRINT SAMPLE
1	4	BRADY 12345
2	5	BRADY 12345
3	6	BRADY 12345
4	7	BRADY 12345
5	9	BRADY 12345
6	10	BRADY 12345
7	11	BRADY 12345

FONT NUMBER	POINT SIZE	PRINT SAMPLE
8	13	BRADY 12345
9	14	BRADY 12345
10	17	BRADY 12345
11	20	BRADY 12345
12	23	BRADY 12345
13	26	BRADY 12345
14	28	BRADY 12345
15	36	BRADY 123
16	45	BRADY 1
17	51	BRADY
18	56	BRADY
19	72	BRAD

Clearing the Legend

Use the following keys to clear the legend:

Keys	Description
<Legend Clear>	Clears all characters from the currently displayed label line while keeping the font size unchanged.
<Shift> + <Legend Clear>	Clears all characters on the legend while keeping the font size for all label lines unchanged.
<Shift> + <Form Clear>	Deletes all characters and lines on the legend, resets the font size to the default, and positions the cursor in the first character position on line one.

Values set in the Setup Menu (such as rotation, or horizontal and vertical justification) remain unchanged when performing any of the above actions or when you turn the unit off. Values change to the default values if a new marker roll with a different marker size is loaded into the unit.

Saving and Recalling a Legend

Any legend entered on the text editor is retained when the unit is turned off. Turn the unit back on and the legend reappears on the display. This rule holds true only if the part number of the marker roll loaded in the unit is not changed while the unit is turned off. If the TLS2200™ printer detects a marker size change when turned on, or if a different marker size is loaded while the unit is on, text on the display is cleared and the default font size is set.

Once you have finished entering and editing your text, you may wish to save your legend for retrieval at some later point in time. The TLS2200™ printer allows you to save legends to a list. See the Legend Lists section on page 30 for more information.

Function Keys

The use of each function key is described in the chart below:

Key	Description
Feed	Advances to the next marker.
Print	Prints the legend.
Multi Print	Prints multiple copies of the legend (1-250).
Serial	Serializes legend starting with the character at the cursor.
Exit	Exits you back to the text editor screen from any Serial, Multi Print, Setup Menu, or List Menu screen.
Peel	Advances label to peel position. Note: You cannot use this function with PSPT label rolls (PermaSleeve).
Barcode	Toggles legend type status (Text, Barcode).
Shift + >	Increases font size.
Shift + ?	Decreases font size.
Shift + Wire	Toggles label format (Component, Wire).
Setup	Displays Setup Menu options.
Save	Saves the currently displayed legend to a legend list.
Recall	Recalls the previously saved legend to a legend list.
List	Displays List Menu.
Form	RESERVED FOR FUTURE USE.
Form Clear	RESERVED FOR FUTURE USE.

Printing Your Labels

Adjusting Burn Temperature

The burn temperature setting can be adjusted to darken or lighten your printed legend. Cases where adjustments are needed should be rare as the TLS2200™ printer automatically optimizes the burn temperature based on the material loaded in the unit.



Note: The burn temperature is automatically reset to its default setting of 0 each time the unit is turned off. *To obtain further information on adjusting the burn temperature, refer to The Setup Menu section on page 13.*

Setting Peel Time

After your label(s) are printed, the TLS2200 printer feeds the last printed label to the cut-off position. If you wish to remove (peel) the last printed label from the liner without cutting, the peel function can be used. Simply Press **<Func> + <Peel>** on the keypad and the unit advances the last printed label forward to the peel position. Depending on how the default is set, you have from 2 to 9 seconds to peel the label from the liner before it returns to the cut-off position. *For more information on setting the peel time, refer to The Setup Menu section on page 13.*



Note: The peel time option is not supported for BradySleeve and PermaSleeve label parts. After printing, BradySleeve advances to the tear-off position and PermaSleeve advances to the cut position.

Printing Larger Labels

Die cut label formats greater than 1.9" x 2.0" will print with version 2 software or higher. If you are using version 1 software, you will be able to print larger labels, but only up to the printable area limits of 1.81" x 1.81". *Refer to Appendix 3: Using the TLS2200™ Program Installer for help with installing new software on your TLS2200 printer.*

Reloading Marker Rolls and Ribbons

If the marker roll runs out of labels while printing, the TLS2200™ printer stops printing and the following message appears:

“Error Out of Label”

When the marker roll runs out, the print job is permanently cancelled. Any legends remaining to be printed are aborted. To continue printing, follow the instructions below.

1. Using the cutter mechanism, cut-off any labels that have already printed.
2. Pull the ribbon cartridge-locking lever towards the front of the printer to open the print head.
3. Pull any remaining markers out through the top of the printer.
4. Install a new marker roll. *For instructions, refer to the Install a Marker Roll section on page 8.*
5. Initiate a new print job to continue from where the previous one ended.

If the ribbon runs out while printing, the TLS2200 printer stops printing and displays the following message:

“Error Out of Ribbon”

Similar to the situation with marker rolls, when the ribbon cartridge runs out of ribbon, the print job is permanently cancelled. Any legends remaining to be printed are aborted. To continue printing, insert a new ribbon cartridge, then initiate a new print job to continue from where the previous one ended.



Note: When a marker roll or ribbon cartridge runs out, the legend entered on the LCD continues to display. This allows you to make a marker roll/ribbon replacement without losing your text. However, the display is cleared if the size of the markers on the new marker roll differs from those on the roll being replaced.

Advanced Features

Features outlined in this section pertain to advanced user options. You will find instructions for generating serialized, legend list, terminal block, and barcode labels.

Serialized Labels

This section discusses making serialized labels with the TLS2200™ printer.

Serialization

Legends you create with the TLS2200 printer can be serialized both numerically and alphabetically. Serializing characters in a legend results in a series of markers that increment by one number and/or one letter.

The TLS2200 printer allows you to create two different types of serialization patterns:

Pattern	Description
Standard	Defaults serial number scheme to decimal (0-9) or alpha (A-Z, a-z) based on character type entered.
Octal	Defaults the serial number scheme to octal (Base 8) 0-7 numeric serialization.

Your serialization type defaults to either standard or octal based on the selection you choose from the Setup Menu. *For instructions on how to set the serial default, refer to The Setup Menu section beginning on page 13.*

To create labels containing serialized data, follow the instructions below:

1. Enter the text to be serialized on the appropriate legend line.
2. Use the <=> key to position the cursor over the last character in the legend to be serialized.
3. Press <Func> + <Serial> on the keypad. The screen prompts you to enter the number of times to increment the serial number with "No. to Serial?".
4. Enter the number of times to increment the serial number and press <Enter>. The screen prompts you to enter the number of copies of each number to print with "No. of Copies?".
5. Enter the number of copies to print and press either <Enter> or <Print>. Your serialized markers are printed.

General Guidelines for Serializing

Use the following guidelines for serializing:

- Both lowercase and uppercase characters can be serialized.
- Serialized characters can be incremented only (cannot decrement).

- You can choose only one serial type per label (standard or octal).
- Serialized text is limited to one line and one sequence per label.
- The printer first serializes the character the cursor is highlighted on when the **<Func>** + **<Serial>** keys are pressed. When this character reaches its maximum value (9, z, or Z if standard, 7 if octal), the character immediately to the left is incremented, and the right most character cycles back to its minimum value (0, a, or A if standard, 0 if octal).
- Once a serialized character has reached its maximum value and the next character encountered to the left is a non-serializable character (such as a space, accented character, or symbol), the serial pattern cycles back to begin incrementing again from the rightmost serialized character.
- After printing a series of serial characters, the editor displays the next logical character in the serial pattern (example: Print 1 to 5. After print job is completed, editor displays 6).

Legend Lists

This section discusses making legend lists with the TLS2200™ printer.

What Is A Legend List?

A legend list consists of one or more legends stored under a list name. The storage capability of the TLS2200™ allows you to create, select, print, and edit legend lists.

It is recommended that you review the following terminology before you start working with legend lists:

Term	Definition
Legend —	The actual text to be printed on a marker. The legend appears on the Text Editor screen and can be stored in memory.
Legend List —	One or more legends stored under a list name.
Active Legend List —	A list becomes active when you create or select it. See <i>Creating a New List</i> and <i>Selecting a List</i> later in this section. A list that has been activated is ready to be printed or edited.
Recalled Legend —	A legend is recalled when you press <Func>+<Recall> or <Func>+<Shift>+<Recall> from within an active legend list. See <i>Editing a List</i> later in this section. A legend that has been recalled is ready to be edited.

General Guidelines for Legend Lists.

Use the following guidelines for legend lists:

- Legends for legend lists are created following the same guidelines as non-list legends.
- All style features accessible through the Setup Menu are available when creating legends for lists.
- Individual legends within legend lists can have different styles.
- You cannot save serialized legends to a list.
- The maximum number of legends you can save to a list will vary depending on how much memory the legends in your list use. The amount of memory used by a legend is dependent on certain variables such as the number of lines in the legend and the number of characters per line. For example, if your list contains legends that all have five lines and eight characters per line, you could save approximately 800 total legends to memory. If your list contains legends that all have one line and eight characters per line, you could save over 2,700 total legends to memory.

- A maximum of 10 legend lists can be stored in the printer at any one time.

The List Menu

To bring up the List menu, press **<List>** on the keypad. The List menu contains the following user options:

Option	Description
Select	Activates a list for editing or printing.
Create	Creates a new list.
Print	Prints a list.
Edit	Toggles either <i>on</i> or <i>off</i> . Edits a list when: <ul style="list-style-type: none"> • a part is not installed in the printer. -or- • a part other than the part the list was created for is installed in the printer.
Delete	Deletes a list from memory.

Creating a New List

To create a new list, follow the instructions below:

1. Press **<List>** to access the List Menu.
2. Press the **<?>** key once to select *Create*, then press **<Enter>**.

If the error message “Memory Full” displays on the Text Editor screen, the maximum number of lists (ten) is already saved in memory. In order to proceed, you must delete one or more lists from memory. Refer to *Deleting a List* later in this section for instructions.

3. At the prompt “Enter List Name”, enter a name for your new list, then press **<Enter>**. A list name of up to 16 character is allowed. All the characters on the keypad are valid for list names.
4. At the prompt “Enter Part No.”, enter the entire part number as it appears on the end of the marker roll core. For example, PTL-19-423.
5. Press **<Enter>**. The Text Editor screen appears.



The list is created specifically for the part number entered at the time the list was created. **You cannot create a list unless a marker roll is loaded.**

6. Enter text to create the first legend for your list.
7. Press **<Func>+<Save>** to save your legend to the list.

If the error message “Memory Full” displays on the Text Editor screen, the memory has reached capacity. In order to proceed, you must either delete one or more legends from a

list, or delete one or more lists from memory. Refer to *Deleting a List* later in this section for instructions. To delete a legend from a list, press **<Func>+<Shift>+<Delete>**.

8. Press **<Shift>+<Legend Clear>** to clear the text from the Text Editor screen.



Pressing **<Shift>+<Legend Clear>** deletes all text in the legend from the Text Editor screen. Press **<Legend Clear>** to delete text from only one line (the line currently displayed).

Once a legend is saved to a list, pressing **<Legend Clear>** or **<Shift>+<Legend Clear>** only deletes text from the screen, not from the list. Refer to *Editing a List* for instructions on deleting legends from a list.

9. Enter text for a second legend.
10. Press **<Func>+<Save>** to save the second legend to the list.

Continue this process of creating and saving until all legends are entered into your list.

11. To exit the current list, turn the power off.

To exit (deactivate) a list, you can create a new list, select a list, or turn the power off.

Selecting a List

Selecting a List will make it active for printing and editing. To select a list, follow the instructions below:

1. Press **<List>** to activate the List Menu.
2. The cursor is on *Select*. Press **<Enter>**. You will be prompted with all list names stored in the printer (up to 10). The last activated list will display on the Text Editor screen.
3. Use the **<=>** and **<?>** keys to select the name of the list you want to activate, then press **<Enter>**. The part number you originally entered briefly displays, followed by the Text Editor screen.

Your list is now activated for printing or editing.

Printing a List

To print a list, follow the instructions below:

1. If you do not have a list active, create or select a list. Refer to *Create a New List* and *Selecting a List* earlier in this section for instructions.
2. Press **<List>** to access the List Menu.

You must go through the List Menu in order to print a list. Simply pressing **<Print>** will print only the legend shown in the Text Editor screen.

3. Press the **<?>** key twice to select *Print*, then press **<Enter>**. If no list is active, “Invalid Function” is displayed on the Text Editor screen.
4. If a list is activated and you have recalled a legend, you are prompted to choose “Entire List” or “From Current”. Select “From Current” if you want to print only the part of the list from the legend currently displayed forward. If you run out of ribbon or markers during a list print, press **<Enter>** to return to the the legend where the printer stopped.
5. At the prompt “No. of Copies?”, enter the number of times you want the active list to print (up to 250) and press **<Enter>**.

This is the number of copies of each label within the list. If two copies are requested, the labels will print in this order [1,1,2,2,3,3...]. You cannot print multiple copies of the list in this order [1,2,3,1,2,3...] from the *Print* option.



Note: If a list is activated but no legends are recalled, the Print option goes directly to the “No. of Copies?” prompt.

Although a list is typically printed on the part it was created for, you can print the list using any part that has a printable area greater than or equal to the part for which the list was originally created in both the X and Y dimensions. However, if you try to print on a smaller label, the error message “Invalid Function” will display on the Text Editor screen.

Editing a List

Editing a list involves deleting legends from a list and changing characters in a legend already in a saved list.

There are two ways to edit an active list:

1. If you have the correct part (the part the list was originally created for) installed in the printer, you can recall legends from the active list and then edit them the same way you would edit a non-list legend.
2. If you do not have the correct part (or do not have any part) installed in the printer, you can still edit a list through Edit mode. Edit mode is explained later in this section.

To edit a list:

1. Select the list that you want to edit. Refer to *Selecting a List* earlier in this section for instructions.

You cannot select a list unless the correct part (the part the list was created for) is loaded in the printer. If you try to select a list without the correct part loaded in the printer, or no part is loaded in the printer, this error message will display on the Text Editor screen:

The part your list
was created for.

**Wrong Part! Use
PTL-XX-XXX**

***This message will only display
if the Edit mode is off.***

This message will also display if you are trying to save a legend to an active list, and the wrong part (a part other than the part the list was created for), or no part, is loaded in the printer.



If you do not remember the correct part for the list you want to edit, place the cursor on your list name (after choosing *Select*), then press the <<> key. The correct part displays on the Text Editor screen, **providing that you entered it when you created the list**. See *Creating a List* earlier in this section. Press the <=> key to return to the list name.

In order to delete or edit a legend in a list, you must recall the legend. When you activate a list, the last legend you entered will display on the Text Editor screen. However, this does not mean that the legend is recalled.

2. Recall a legend from the active list.

- Press <Func>+<Recall> to recall the next legend in a list.
- Press <Func>+<Shift>+<Recall> to recall the previous legend in a list.

If you want to delete a legend:

Press <Func>+<Shift>+<Delete>. The legend is deleted from the active list.

If you want to change characters in a legend:

1. Edit the legend following the normal guidelines for non-list legends.

All style options for editing non-list legends can be used to edit legends within a list, and different legends can have different styles even though they belong to the same list. Style options include:

- H Justify
- V Justify
- Format
- Font Size
- Rotation

2. Press <Func>+<Save> to save the edited legend.

3. When the prompt appears “Save as New” or “Save as Current”, select “Save as Current”. Your edited legend is now saved to the list.

Selecting “Save as New” will add the legend to the end of the list. See *Appending a List*

later in this section for details.

Using Edit Mode

The Edit mode can be toggled to *on* or *off*. Use the Edit mode within the List Menu to modify a list when:

- a part is not installed in the printer.
- or-
- a part other than the part the list was created for is installed in the printer.

To use Edit mode, follow the instructions below:

1. Press **<List>** to activate the List Menu.
2. Press the **<?>** key three times to select *Edit*, then press **<Enter>**
3. The Edit mode defaults to *Off*. Use the **<?>** key to select *On*, then press **<Enter>**.
4. You will be prompted with all list names stored in the printer (up to 10). Use the **<>>** and **<?>** keys to select the list you want to edit, then press **<Enter>**.

The Text Editor screen appears. The left and right arrows on the Status Bar (top line of the screen — see below) are replaced by lighting bolts to indicate that the Edit mode is on.

Text Editor screen with Edit mode *on*.



When in Edit mode, the Print, Feed, and Peel commands are disabled. Turn the Edit mode off to restore these functions.

The Edit mode toggles to *Off* when the printer is turned off.

Appending a List

To append a list means to add legends to a previously saved list. All legends are appended to the end of the list. You cannot save legends to the beginning or middle of a list.

1. If you do not have a list active, select a list. Refer to *Selecting a List* earlier in this section for instructions.
2. Create a legend following the normal guidelines for non-list legends.
3. Press **<Func>+<Save>**.
4. When the prompt appears “Save as New” or “Save as Current”, select “Save as New”. Your legend is now added to the end of the list.

Deleting a List

To delete a list from memory, follow the instructions below:

1. Press **<List>** to activate the List Menu.
2. Press the **<?>** key four times to select *Delete*, then press **<Enter>**. You will be prompted with all the list names stored in the printer (up to 10).
3. Use the **<>>** and **<?>** keys to select the name of the list you want to delete, then press **<Enter>**. After deleting a list, the display returns to the Text Editor screen.

Continuous Printing—Terminal Block Labels

This section discusses making terminal block labels with the TLS2200™ printer.

Creating Terminal Block Labels

Terminal block labels can be created and printed using the TLS2200 printer. Simply choose the appropriate center-to-center spacing repeat (pitch) for the block, enter your text, and print as needed. The number of lines of text available at each termination is dependent on repeat value spacing and the font size chosen.

Setting the Center-to-Center Spacing

The center-to-center spacing (terminal block repeat) is set by accessing the *Term Repeat* option on the Setup Menu. Follow the instructions below to set this option:

1. Press the **<Func>** + **<Setup>** keys to access the Setup Menu.
2. Press the **<?>** key two times to scroll to the Continuous Menu, press the **<Enter>** key.
3. With the cursor on the *Terminal Block* option, press **<Enter>**.
4. Use the arrow keys to adjust the terminal block repeat value, then press **<Enter>**.

The repeat can be set from 2 mm (0.19685 in) to 46 mm (1.81102 in). Press the **< >** and **< ? >** keys to increase/decrease the repeat value by 0.125 mm increments (1 dot). Press the **<Shift>** + **< >** and **<Shift>** + **< ? >** to increase/decrease the repeat value by 1 mm increments (8 dots).



Note: Press **<Feed>** after printing to advance the terminal strip label to the cut position.

Continuous Printing—Banners

You can create banners using the TLS2200™ printer. Banners have a variety of industrial uses, including labeling larger conduit.

 New continuous label parts designed for banner printing such as PTL-8, PTL-42, and PTL-43 can only be used with version 2 software or higher. If you are using version 1 software, you will not be able to enter text on the editor screen. *Refer to Appendix 3: Using the TLS2200™ Program Installer for help with installing new software on your TLS2200 printer.*

To create a banner, complete the following steps:

1. Press the **<Func>** + **<Setup>** keys to access the Setup Menu.
2. Press the **< ? >** key twice to select *Continuous*, then press **<Enter>**.
3. Press the **< ? >** key once to select *Banner*, then press **<Enter>**.
4. Use the **< > >** and **< ? >** keys to select the desired rotation, then press **<Enter>**.
5. Press **<Func>** + **<Exit>** to exit back to the Text Editor screen.
6. Enter the banner text as needed and print your label. The first banner label printed will have an additional 1" of material fed before the text prints. After the first banner label prints, press **<feed>** and then cut to avoid excess waste on subsequent labels.

Banner Rotation

Banners can be printed either horizontally or vertically.

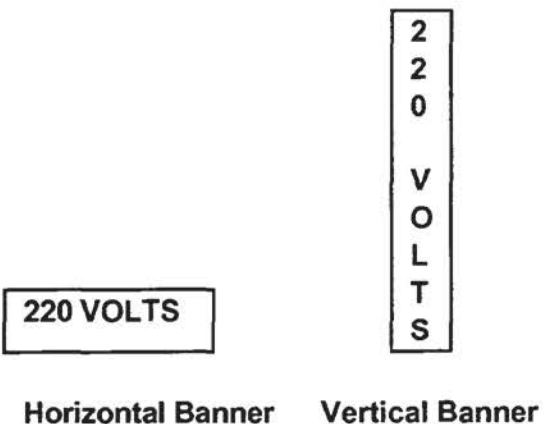

Default Font Size

For continuous printed labels (banners), the default font size is the largest font that prints on the selected marker width in horizontal orientation.

Fixed Length Banners

With the TLS2200 printer, you can specify a fixed length for the banner. Values range from a banner length of 26mm (1.02362 in) to a banner length of 312mm (12.28346 in).

You can set the banner length in increments of 1mm by pressing the **<Func>+<>>** or **<?>** keys.

Fixed length allows you to use the H Justify to specify at which point on the banner you want the text to appear. The H Justify option allows Left, Center, and Right justification.

Barcode Labels

This section discusses making barcode labels with the TLS2200™ printer.

Creating Barcode Labels

The TLS2200 printer allows you to create Code 39 barcodes for your labels. Legends made utilizing the bar-coding feature can consist of a single barcode, several barcodes, or barcodes together with text.

Setting Barcode Options

When adding a barcode to your label, several options can be accessed to customize how your barcode(s) are formatted and printed. Options available are as follows:

Legend Type: This setting is used to select the Legend Entry Mode. Pressing the **<Barcode>** key allows you to toggle between *Text* and *Barcode*. When set to *Barcode* mode, all text entered on the line/label print as a Code 39 barcode. The Status Bar (first line on the LCD) displays a *B* to indicate you are in Barcode mode.

Bar Height: This setting can be accessed from the Barcode submenu on the Setup Menu. This option allows you to set the height of your Code 39 barcode(s). Heights range from 1 to 26 millimeters and can be increased/decreased in 1-millimeter increments.

Human Readable: This setting is also accessed from the Barcode submenu on the Setup Menu. This option allows you to determine whether your barcode(s) are printed together with human readable text (toggles on and off). Barcode human readable text print at a font size of 2 (5 point) up to 9 (14 point).

Rotation: This option, located on the Setup sub-menu named *Style*, allows you to set

the rotation of your barcode(s) in one of four orientations (0E, 90E, 180E, 270E). This allows you to create both picket fence and ladder style barcodes. Please note, however, that all lines on the legend (text and/or barcode) print at the rotation selected. Lines cannot be rotated independently.

Code 39 Barcode Symbology

The barcode symbology used by the TLS2200 printer is *Code 39*. The character set for this symbology consists of the following characters:

The capital letters: **A to Z**
 The numbers: **0 to 9**
 The **space** character
 The symbols: **- . \$ / + %**

Characters entered in lowercase are automatically converted to uppercase when printed.

TLS2200 Printer Barcode Parameters

Symbology: Code 39
 Narrow Bar Width: 2 dots (.25mm)
 Wide-to-Narrow Ratio: 2 to 1
 Quiet Zone: 10 dots (1.25mm)
 Density 7.82 CPI

Maximum Barcode Characters

The maximum number of characters for a bar code is 25. The following table lists the maximum barcode characters per line:

Marker Width	Max # of Barcode Chars Per Line
12.7 mm (0.5 in.)	* 0
25.4 mm (1.0 in.)	4
38.1 mm (1.5 in.)	8

* Zero characters allowed on label (quiet zone and start/stop characters occupy entire width).

To create labels containing barcodes, follow the instructions below:

1. Press the **<Barcode>** key to toggle the legend type from *Text* to *Barcode* mode (*B* is displayed on the Status Bar).
2. Press the **<Func> + <Setup>** keys to access the Setup Menu.
3. Press the **< ? >** key once to select *Barcode*, then press **<Enter>**.
4. With the cursor highlighted on *Bar Height*, press **<Enter>**.

5. Use the < > > and < ? > keys to set the height of your barcode(s), then press <Enter>.
6. Press the < ? > key once to select *Human Readable*, then press <Enter>.
7. Press the < > > or < ? > keys to toggle the human readable text on or off as required, then press <Enter>.
8. If human readable, press the < > > or < ? > keys to select the text font size desired, then press <Enter>.
9. Press the <Delete> key to back out one level in the Setup Menu tree.
10. Press the < ? > key twice to select *Style*, then press <Enter>.
11. With the cursor highlighted on *Rotation*, press <Enter>.
12. Use the < > > and < ? > keys to select the desired rotation, then press <Enter>.
13. Press <Func> + <Exit> to exit back to the Text Editor screen.
14. Enter barcode text as needed and print your label.

Multiple Barcodes

Multiple barcodes can be entered on a label, but only one barcode can be entered per line. Bar height can be set to one height only per label regardless of the number of barcodes entered on the label.

Switching Between Text and Barcode Mode

Text already entered on a line can be switched from *Text* to *Barcode* mode and vice versa. If the size of the barcode or text being switched to does not fit on the label, you encounter the message "Reduce Type Size" when you attempt to print the label. You must scroll to the line where the switch was made, reduce the size of the font (if text) or bar height (if a barcode), and print again.



Note: You cannot switch the legend mode from *Text* to *Barcode* if a line contains any invalid Code 39 barcode characters.

Tutorial Guide

The following pages provide step-by-step instructions for creating and printing labels using a variety of different printer functions.

The part number of the marker roll used is noted at the beginning of each tutorial. Many of the tutorials use part number PTL-19-423. A sample roll of this 1" x 1" marker is provided in your TLS2200™ Thermal Labeling System package.

T1: Creating a One-Line Legend, Component Marker



Note: This example assumes you have marker roll **PTL-19-423** loaded in your printer.

Label to be printed:

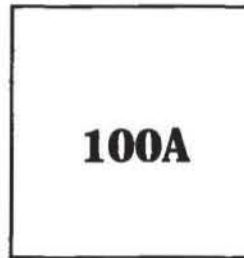

Setup Status:

H Justify	Center
V Justify	Center
Rotation	0 Degrees
Format	Component

1. Check the Status Bar to make sure the unit is in Component mode. If not, press **<Shift> + <Wire>** to toggle from Wiremarker mode to Component mode.
2. Enter **100A** on line one. (Font is set at default size - 9)
3. Press **<Print>**.

T2: Creating a Component Label Utilizing Multiple Font Sizes



Note: This example assumes you have marker roll **PTL-19-423** loaded in your printer.

Label to be printed:

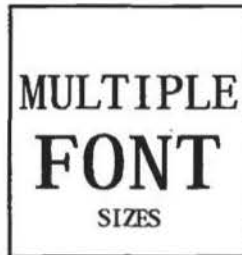

Setup Status:

H Justify	Center
V Justify	Center
Rotation	0 Degrees
Format	Component

1. Press **<Legend Clear>** to clear the text from line one.
2. With the font size set at the default of 9, enter **MULTIPLE** on line one, then press **<Enter>**.
3. Press **<Shift> + <>>** three times to increase the font size to 12.
4. Enter **FONT** on line two, then press **<Enter>**.
5. Press **<Shift> + <?>** eight times to decrease the font size from 12 to 4.
6. Enter **SIZES** on line three.
7. Press **<Print>**.

T3: Creating a Wiremarker



Note: This example assumes you have marker roll **PTL-19-423** loaded in your printer.

Label to be printed:

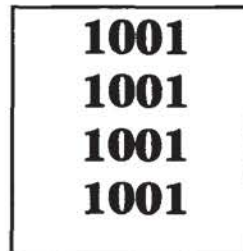

Setup Status:

H Justify	Center
V Justify	Center
Rotation	0 Degrees
Format	Component

1. Press **<Shift> + <Form Clear>** to delete all lines of text and reset the font to the default value of 9.
2. Press **<Shift> + <Wire>** to change format mode from *Component* to *Wire* (note the change from *C* to *W* on the LCD Status Bar).
3. Enter **1001** on line one.
4. Press **<Print>**.

T4: Creating Serialized Wiremarkers



Note: This example assumes you have marker roll **PTL-19-423** loaded in your printer.

Labels to be printed:

A201 A201 A201 A201
• • • •
A205 A205 A205 A205

Setup Status:

H Justify	Center
V Justify	Center
Rotation	0 Degrees
Format	Wire

1. Press **<Legend Clear>** to clear the text from line one.
2. Check the Status Bar to make sure the unit is in Wiremarker mode. If not, press **<Shift> + <Wire>** to toggle from Component mode to Wiremarker mode.
3. Enter **A201** on line one.
4. Press **<=>** to position the cursor under the last character.
5. Press **<Func> + <Serial>**.
6. When “No. to Serial?” prompt appears, enter **5**, then press **<Enter>**.
7. When “No. of Copies?” prompt appears, enter **2**.

- Press **<Enter>** or **<Print>**. The printer begins printing two each of the five wiremarkers listed above.

T5: Creating a Label with Rotated Text, Printing Multiple Copies



Note: This example assumes you have marker roll **PTL-19-423** loaded in your printer.

Label to be printed:

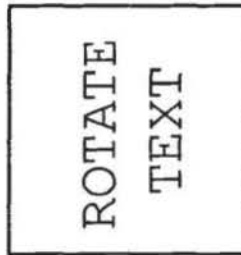

Setup Status:

H Justify	Center
V Justify	Center
Rotation	0 Degrees
Format	Component

- Check the Status Bar to make sure the unit is in Component mode. If not, press **<Shift>** + **<Wire>** to toggle from Wiremarker mode to Component mode.
- Press **<Shift>** + **<Form Clear>** to delete all lines of text and reset the font to the default size of 9.
- Press **<Func>** + **<Setup>** to access the Setup Menu.
- Press **<?>** three times to move to the Style sub-menu, then press **<Enter>**.
- With the cursor highlighted on *Rotation*, press **<Enter>**.
- Press the **<>>** key once to select *90 Degrees*.
- Press **<Enter>**.
- Press **<Func>** + **<Exit>** to exit back to the text editor screen.
- Press **<Shift>** + **<>>** once to increase the font size to 10.
- Enter **ROTATE** on line one, then press **<Enter>**.

11. Enter **TEXT** on line two.
12. Press **<Func>+<Multi Print>**.
13. When “No. of Copies?” prompt appears, enter **3**.
14. Press **<Enter>**. The printer prints three copies of the legend created above.

T6: Creating a Barcode Label



Note: This example assumes you have marker roll **PTL-19-423** loaded in your printer.

Label to be printed:

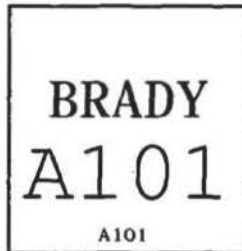

Setup Status:

H Justify	Center
V Justify	Center
Rotation	0 Degrees
Format	Component
Legend Type	Text

1. Press **<Shift>** + **<Form Clear>** to delete all lines of text and reset the font to the default value of 9.
2. Press **<Func>** + **<Setup>** to access the Setup Menu.
3. Press **<?>** three times to move to the Style sub-menu, then press **<Enter>**.
4. With the cursor highlighted on *Rotation*, press **<Enter>**.
5. Press the **<?>** key once to select *0 Degrees*.
6. Press **<Enter>**.
7. Press **<Delete>** to return to the Setup Menu.
8. Press the **<>>** key twice to select *Barcode*, then press **<Enter>**.
9. With the cursor highlighted on *Bar Height*, press **<Enter>**.
10. Use the **<>>** and **<?>** keys as needed to set the height of your barcode to 8mm (0.31496 in.), then press **<Enter>**.
11. Press the **<?>** key once to select *Human Readable*, then press **<Enter>**.
12. Press the **<>>** or **<?>** keys to toggle the human readable text ON, then press **<Enter>**.

13. Press the <> or <?> keys as needed to set the font size to 3, then press <Enter>.
14. Press <Func> + <Exit> to exit back to the Text Editor screen.
15. With the cursor highlighted on line one, press <Shift> + <> two times to increase the font size from 9 to 11.
16. Enter **BRADY** on line one, then press <Enter>.
17. Press the <Barcode> key to toggle the Legend Type for line two from *Text* to *Barcode* mode (*B* is displayed on the Status Bar).
18. Enter **A101** on line two.
19. Press <Print>.

T7: Creating a Serialized Barcode Label



Note: This example assumes you have marker roll **PTL-19-423** loaded in your printer.

Labels to be printed:

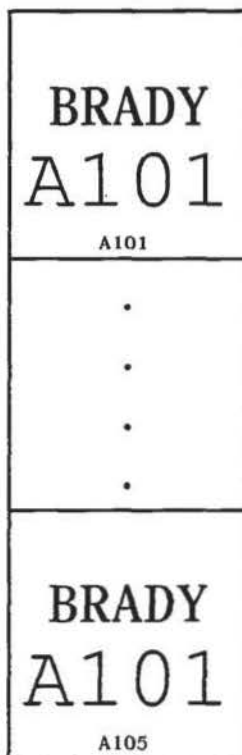

Setup Status:

H Justify	Center
V Justify	Center
Rotation	0 Degrees
Format	Component
Legend Type	Text

1. Repeat steps 1-17 from *Creating a Barcode Label*.
2. Press **<=>** to position the cursor under the last character.
3. Press **<Func> + <Serial>**.
4. When “No. to Serial?” prompt appears, enter **5**, then press **<Enter>**.
5. When “No. of Copies?” prompt appears, enter **1**.
6. Press **<Enter>** or **<Print>**. The printer begins printing one each of the five serialized

barcode labels from **A101** to **A105**.

T8: Creating a Terminal Block Label



Note: This example assumes you have the terminal block marker roll **PTLTB-400-375** loaded in your printer.

Label to be printed:

101
102
103
104
105
106
107
108
109
110

Setup Status:

H Justify	Center
V Justify	Center
Rotation	0 Degrees
Format	Component
Legend Type	Text

1. Press **<Shift>** + **<Form Clear>** to delete all lines of text and reset the font to the default value of 6.
2. Press **<Func>** + **<Setup>** to access the Setup Menu.
3. Press the **<?>** key six times to select *Units*, then press **<Enter>**.
4. Press the **<>>** or **<?>** keys to toggle the Units to *Metric*, then press **<Enter>**.
5. Press the **<>>** key four times to select *Continuous*, then press **<Enter>**.
6. With the cursor highlighted on *Terminal Block*, press **<Enter>**.
7. Use the **<>>** and **<?>** keys as needed to set the terminal block repeat value to 6 mm (.23622 in.), then press **<Enter>**.

8. Press **<Func>** + **<Exit>** to exit back to the Text Editor screen.
9. With the cursor highlighted on line one, press **<Shift>** + **<>** once to increase the font size from 6 to 7.
10. Enter **101** on line one.
11. Press **<=>**.
12. Press **<Func>** + **<Serial>**.
13. When “No. to Serial?” prompt appears, enter **10**, then press **<Enter>**.
14. When “No. of Copies?” prompt appears, enter **1**.
15. Press **<Enter>** or **<Print>**. The printer should print ten times along the terminal block marker (**101** through **110**).
16. Press **<Feed>** to advance printed terminal strip label to the cut position.

T9: Creating a Patch Panel Label



Note: This example assumes you have the continuous marker roll **PTL-8-422** loaded in your printer.

Label to be printed:

C812
01D
C812
02D
C812
03D
C812
04D
C812
05D
C812
06D
C812
07D
C812
08D
C812
09D
C812
10D
C812
11D
C812
12D

Setup Status:

H Justify	Center
V Justify	Center
Rotation	0 Degrees
Format	Component
Legend Type	Text

1. Press **<Shift>** + **<Form Clear>** to delete all lines of text and reset the font to the default value of 14.
2. Press **<Func>** + **<Setup>** to access the Setup Menu.
3. Press the **<?>** key six times to select *Units*, then press **<Enter>**.
4. Press the **<>>** or **<?>** keys to toggle the Units to *Inches*, then press **<Enter>**.
5. Press the **<>>** key four times to select *Continuous*, then press **<Enter>**.
6. Press the **<>>** key once to choose *Terminal Block*, then press **<Enter>**.
7. Use the **<>>** and **<?>** keys as needed to set the terminal block repeat value to 0.60039 (15.25 mm), then press **<Enter>**.
8. Press **<Func>** + **<Exit>** to exit back to the Text Editor screen.
9. With the cursor highlighted on line one, press **<Shift>** + **<>>** once to increase the font size from 5 to 6.
10. Enter **C012** on line one, then press **<Enter>**.
11. Enter **01D** on line two.
12. Press the **<=>** key twice.
13. Press **<Func>** + **<Serial>**.

14. When “No. to Serial?” prompt appears, enter **12**, then press **<Enter>**.
15. When “No. of Copies?” prompt appears, enter **1**.
16. Press **<Enter>** or **<Print>**. The printer should print twelve times along the patch panel label (**01D** through **12D**).
17. Press **<Feed>** to advance printed patch panel label to the cut position.

T10: Creating a Continuous Label



Note: This example assumes you have the continuous marker roll **PTL-8-422** loaded in your printer.

Print the following label to be used to identify communications equipment:

BX1.10H2CC 10 Base T HUB TO 2ND FLOOR CALL CENTER

Setup Status:

H Justify	Left
V Justify	Center
Rotation	0 Degrees
Format	Component
Legend Type	Text

1. Press **<Shift> + <Form Clear>** to delete all lines of text and reset the font to the default value of 14.
2. Press **<Func> + <Setup>** to access the Setup Menu.
3. Press the **<?>** key three times to select *Style*, then press **<Enter>**.
4. Press the **<?>** key once to select *H Justify*, then press **<Enter>**.
5. Press the **<>>** or **<?>** keys to select *Left*, then press **<Enter>**.
6. Press the **<Delete>** button to exit back to the Setup Menu.
7. Press the **<>>** key once to select *Continuous*, then press **<Enter>**.
8. Press the **<?>** key once to select *Banner*, then press **<Enter>**.
9. Press the **<>>** or **<?>** keys to toggle the direction to *Horizontal*, then press **<Enter>**.
10. Press **<Func> + <Exit>** to exit back to the Text Editor screen.
11. Enter **BX1.10H2CC 10 Base T HUB TO 2ND FLOOR CALL CENTER** on line one.
12. Press **<Print>**.

T11: Creating a Banner Label of Fixed Length



Note: This example assumes you have the banner marker roll **PTL-43-439OR** loaded in your printer.

Print the following label to be used to identify an electrical conduit:

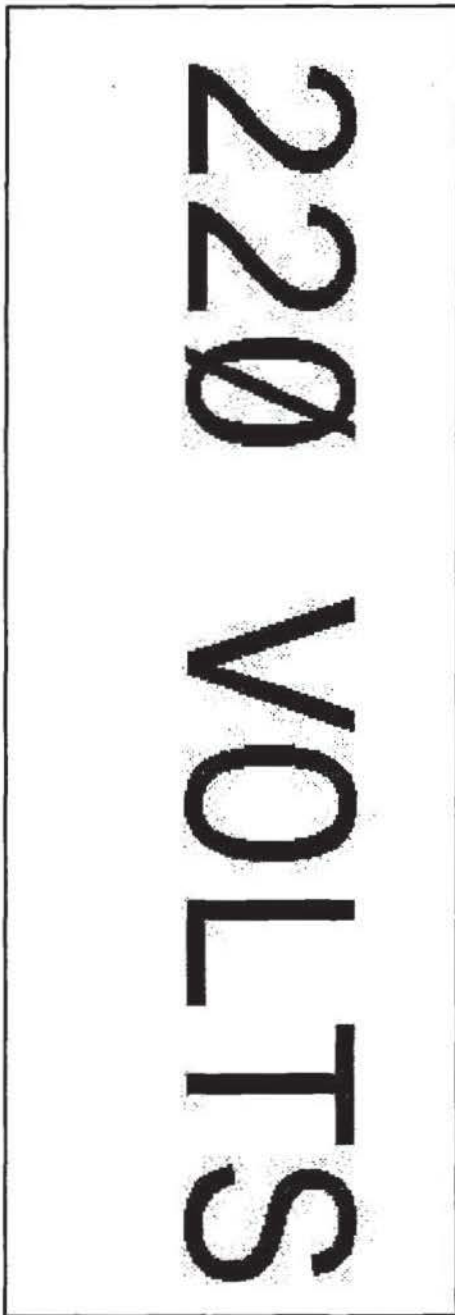

Setup Status:

H Justify	Center
V Justify	Center
Rotation	0 Degrees
Format	Component
Legend Type	Text

1. Press **<Shift>** + **<Form Clear>** to delete all lines of text and reset the font to the default value of 19.
2. Press **<Func>** + **<Setup>** to access the Setup Menu.
3. Press the **<?>** key six times to select *Units*, then press **<Enter>**.
4. Press the **<>>** or **<?>** keys to toggle the Units to *Metric*, then press **<Enter>**.
5. Press the **<>>** key four times to select *Continuous*, then press **<Enter>**.
6. Press the **<?>** key once to select *Fixed Length*, then press **<Enter>**.
7. Use the **<>>** and **<?>** keys as needed to set the fixed length repeat value to 143.000mm (5.62992 inches), then press **<Enter>**.
8. Press **<Func>** + **<Exit>** to exit back to the Text Editor screen.
9. Enter **220 VOLTS** on line one.

10. Press **<Print>**.
11. Press **<Feed>** to advance the banner to the cut position.

T12: Creating a Legend List, Component Markers



Note: This example assumes you have marker roll **PTL-19-423** loaded in your printer.

Labels to be printed:

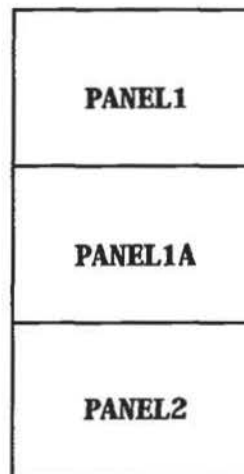

Setup Status:

H Justify	Center
V Justify	Center
Rotation	0 Degrees
Format	Component
Legend Type	Text

1. Press **<List>**.
2. Press the **<?>** key once to select *Create*, then press **<Enter>**.
3. When “Enter List Name” prompt appears, enter LIST1, then press **<Enter>**.
4. When “Enter Part No.” prompt appears, enter PTL-19-423, then press **<Enter>**.
5. Press **<Shift> + <Form Clear>** to delete all lines of text and reset the font to the default value of 9.

6. Enter **PANEL1** on line one.
7. Press **<Func>+<Save>**.
8. Press **<Shift>+<Legend Clear>**.
9. Enter **PANEL1A** on line one.
10. Press **<Func>+<Save>**.
11. Press **<Shift>+<Legend Clear>**.
12. Enter **PANEL2** on line one.
13. Press **<Func>+<Save>**.
14. Press **<List>**.
15. Press the **<?>** key twice to select *Print*, then press **<Enter>**.
16. When the “No. of Copies?” prompt appears, enter **1**, then press **<Enter>**.

T13: Creating a Legend List Utilizing Multiple Font Sizes and Rotations.



Note: This example assumes you have marker roll **PTL-19-423** loaded in your printer.

Labels to be printed:

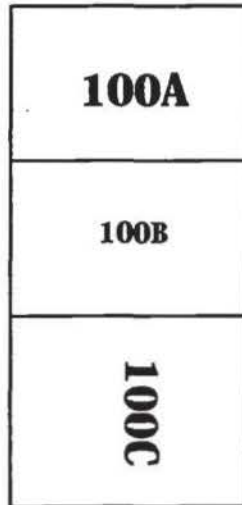

Setup Status:

H Justify	Center
V Justify	Center
Rotation	0 Degrees
Format	Component
Legend Type	Text

1. Press **<List>**.
2. Press the **<?>** key once to select *Create*, then press **<Enter>**.
3. When “Enter List Name” prompt appears, enter LIST2, then press **<Enter>**.
4. When “Enter Part No.” prompt appears, enter PTL-19-423, then press **<Enter>**.
5. Press **<Shift> + <Form Clear>** to delete all lines of text and reset the font to the default value of 9.
6. Enter **100A** on line one.
7. Press **<Func>+<Save>**.
8. Press **<Shift>+<Legend Clear>**.

9. Press **<Shift>+<?>** twice to reduce the font size to 7.
10. Enter **100B** on line one.
11. Press **<Func>+<Save>**.
12. Press **<Shift>+<Legend Clear>**.
13. Press **<Func>+<Setup>**.
14. Press the **<?>** three times to select *Style*, then press **<Enter>**.
15. With the cursor on *Rotation*, press **<Enter>**.
16. Press the **<◇>** three times to toggle to *270 Degrees*, then press **<Enter>**.
17. Press **<Func>+<Exit>** to return to the Text Editor screen.
18. Enter **100C** on line one.
19. Press **<Func>+<Save>**.
20. Press **<List>**.
21. Press the **<?>** key twice to select *Print*, then press **<Enter>**.
22. When the “No. of Copies?” prompt appears, enter **1**, then press **<Enter>**.

T14: Creating a Legend List, Wiremarkers, Printing Multiple Copies



Note: This example assumes you have marker roll **PTL-19-423** loaded in your printer.

Labels to be printed:

A1000 A1000 A1000 A1000
A2050 A2050 A2050 A2050
A2067 A2067 A2067 A2067

Setup Status:

H Justify	Center
V Justify	Center
Rotation	0 Degrees
Format	Component

1. Press **<List>**.
2. Press the **<?>** key once to select *Create*, then press **<Enter>**.
3. When “Enter List Name” prompt appears, enter **LIST3**, then press **<Enter>**.
4. When “Enter Part No.” prompt appears, enter **PTL-19-423**, then press **<Enter>**.
5. Press **<Shift> + <Form Clear>** to delete all lines of text and reset the font to the default value of 9.
6. Press **<Func>+<Setup>**.
7. Press the **<?>** three times to select *Style*, then press **<Enter>**.

8. With the cursor on *Rotation*, press **<Enter>**.
9. Press the **<>>** or **<?>** keys to toggle to *0 Degrees*, then press **<Enter>**.
10. Press **<Func>+<Exit>** to return to the Text Editor screen.
11. Press **<Shift> + <Wire>** to change format mode from *Component* to *Wire* (note the change from *C* to *W* on the LCD Status Bar).
12. Enter **A1000** on line one.
13. Press **<Func>+<Save>**.
14. Press **<Shift>+<Legend Clear>**.
15. Enter **A2050** on line one.
16. Press **<Func>+<Save>**.
17. Press **<Shift>+<Legend Clear>**.
18. Enter **A2067** on line one.
19. Press **<Func>+<Save>**.
20. Press **<List>**.
21. Press the **<?>** key twice to select *Print*, then press **<Enter>**.
22. When the "No. of Copies?" prompt appears, enter **2**, then press **<Enter>**.

T15: Creating and Recalling a Legend List, Barcode Labels



Note: This example assumes you have marker roll **PTL-19-423** loaded in your printer.

Labels to be printed:

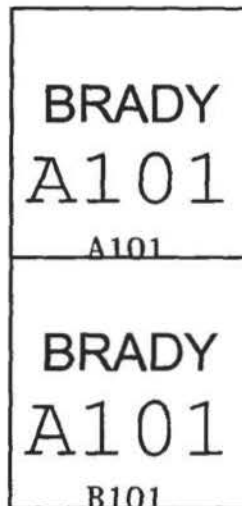

Setup Status:

H Justify	Center
V Justify	Center
Rotation	0 Degrees
Format	Component
Legend Type	Text

1. Press **<List>**.
2. Press the **<?>** key once to select *Create*, then press **<Enter>**.
3. When “Enter List Name” prompt appears, enter LIST4, then press **<Enter>**.
4. When “Enter Part No.” prompt appears, enter PTL-19-423, then press **<Enter>**.
5. Press **<Shift>** + **<Form Clear>** to delete all lines of text and reset the font to the default value of 9.
6. Press **<Func>** + **<Setup>** to access the Setup Menu.
7. Press the **<?>** key once to select *Barcode*, then press **<Enter>**.
8. With the cursor highlighted on *Bar Height*, press **<Enter>**.
9. Use the **<>>** and **<?>** keys as needed to set the height of your barcode to 8mm

(0.31496 in.), then press **<Enter>**.

10. Press the **<?>** key once to select *Human Readable*, then press **<Enter>**.
11. Press the **<>>** or **<?>** keys to toggle the human readable text *ON*, then press **<Enter>**.
12. Press the **<>>** or **<?>** keys as needed to set the font size to 6, then press **<Enter>**.
13. Press **<Func>** + **<Exit>** to exit back to the Text Editor screen.
14. With the cursor highlighted on line one, press **<Shift>** + **<>>** two times to increase the font size from 9 to 11.
15. Enter **BRADY** on line one, then press **<Enter>**.
16. Press the **<Barcode>** key to toggle the Legend Type for line two from *Text* to *Barcode* mode (*B* is displayed on the Status Bar).
17. Enter **A101** on line two.
18. Press **<Func>**+**<Save>**.
19. Press **<Legend Clear>** to clear text from line 2 only.
20. Enter **B101** on line two.
21. Press **<Func>**+**<Save>**.
22. Turn the battery power switch *off* to deactivate List4.

To select (recall) List4 as the active list:

1. Turn the battery power switch *on*.
2. Press **<List>**.
3. With the cursor on *Select*, press **<Enter>**.
4. Use the **<>>** and **<?>** arrows to select List4, then press **<Enter>**. The part number appears, followed by the Text Editor screen. List4 is now the active list.
5. Press **<List>**.
6. Press the **<?>** key twice to select *Print*, then press **<Enter>**.
7. When the "No. of Copies?" prompt appears, enter **1**, then press **<Enter>**.

T16: Creating a Legend List, Recalling and Editing a Legend



Note: This example assumes you have marker roll **PTL-19-423** loaded in your printer.

Labels to be printed:

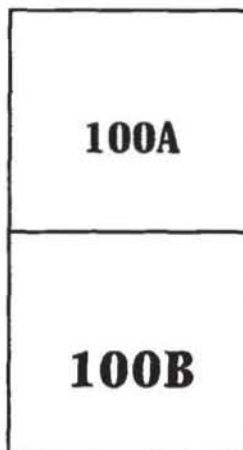

Setup Status:

H Justify	Center
V Justify	Center
Rotation	0 Degrees
Format	Component
Legend Type	Text

1. Press **<List>**.
2. Press the **<?>** key once to select *Create*, then press **<Enter>**.
3. When “Enter List Name” prompt appears, enter LIST5, then press **<Enter>**.
4. When “Enter Part No.” prompt appears, enter PTL-19-423, then press **<Enter>**.
5. Press **<Shift> + <Form Clear>** to delete all lines of text and reset the font to the default value of 9.
6. Enter **100A** on line one.
7. Press **<Func>+<Save>**.
8. Press **<Shift>+<Legend Clear>**.

9. Enter **100B** on line one.
10. Press **<Func>+<Save>**.
11. Turn the battery power switch *off* to deactivate List5.

To select (recall) List5 as the active list:

1. Turn the battery power switch *on*.
2. Press **<List>**.
3. With the cursor on *Select*, press **<Enter>**.
4. Use the **<>** and **<?>** arrows to select List5, then press **<Enter>**. The part number appears, followed by the Text Editor screen.

To add a legend to List5:

1. Press **<Shift> + <Form Clear>** to delete all lines of text and reset the font to the default value of 9.
2. Enter **100C** on line one.
3. Press **<Func>+<Save>**. The legend is added (or *appended*) to the end of List5.

To recall and edit a legend already saved in List5:

1. Press **<Func>+<Recall>** twice to recall the second legend to the Text Editor screen. Legend 100B displays on the Text Editor screen.
2. Press **<Shift>+<>** four times to set the font size to 13.
3. Press **<Func>+<Save>**.
4. When the prompt appears "Save as New" or "Save as Current", press the **<?>** key once to select "Save as Current".
5. Press **<Enter>**. Legend 100B is edited to a larger font size.

To delete a legend already saved in List5.

1. Press **<Func>+<Recall>**. Legend 100C displays on the Test Editor screen.
2. Press **<Func>+<Shift>+<Delete>**. Legend 100C is now deleted from List5.
3. Press **<List>**.
4. Press the **<?>** key twice to select *Print*, then press **<Enter>**.
5. When the "No. of Copies?" prompt appears, enter **1**, then press **<Enter>**.

T17: Creating a Legend List, Banner Legends



Note: This example assumes you have the banner marker roll **PTL-42-439OR** loaded in your printer.

120 VOLTS
CAUTION
COMMUNICATIONS
CLOSET

Setup Status:

H Justify	Center
V Justify	Center
Rotation	0 Degrees
Format	Component
Legend Type	Text

1. Press **<List>**.
2. Press the **<?>** key once to select *Create*, then press **<Enter>**.
3. When “Enter List Name” prompt appears, enter LIST6, then press **<Enter>**.
4. When “Enter Part No.” prompt appears, enter PTL-42-439, then press **<Enter>**.
5. Press **<Shift> + <Form Clear>** to delete all lines of text and reset the font to the default value of 18.
6. Press **<Func> + <Setup>** to access the Setup Menu.
7. Press the **<?>** key six times to select *Units*, then press **<Enter>**.
8. Press the **<>>** or **<?>** keys to toggle the Units to *Metric*, then press **<Enter>**.
9. Press the **<>>** key four times to select *Continuous*, then press **<Enter>**.
10. With the cursor highlighted on *Banner*, press **<Enter>**.
11. Press **<Func> + <Exit>** to exit back to the Text Editor screen.
12. Enter **120 VOLTS** on line one.
13. Press **<Func>+<Save>**.
14. Press **<Shift>+<Legend Clear>**.

15. Enter **CAUTION** on line one.
16. Press **<Func>+<Save>**.
17. Press **<Shift>+<Legend Clear>**.
18. Enter **COMMUNICATIONS CLOSET** on line one.
19. Press **<Func>+<Save>**.
20. Press **<List>**.
21. Press the **<?>** key twice to select *Print*, then press **<Enter>**.
22. When the “No. of Copies?” prompt appears, enter **1**, then press **<Enter>**.

Maintenance

Keep the TLS2200™ printer in good operating condition by performing the following recommended maintenance procedures.

Cleaning the Drive Roller and Cutter

Follow the instructions on the cleaning card shipped with the unit.

Cleaning the Print Head

Remove the cutter mechanism by loosening the screw that holds it in place. Lift the cutter away from the top of the printer mechanism and clean the print head with a cotton swab dipped in isopropyl alcohol. Replace the cutter mechanism.

Accessory Parts List

The following parts and accessories can be ordered from your Brady Worldwide, Inc. supplier:

Description	Stock No.	NAED No.
AC Adapter	TLS2200-AC	18555
Battery Charger	TLS2200-BC	18551
Battery Pack	TLS2200-BP	18554
Cleaning Kit	PCK-5	18556
Communications Cable	TLS2200-CABLE	18574
Cutter Assembly	TLS2200-C	33897
Dust Cover	TLS2200-DC	18553
Hard Side Carrying Case	TLS2200-HC	18552
R4310 Black Ribbon	R4310	18558
R6010 Black Ribbon	R6010	18559
R6210 Black Ribbon	R6210	18560
R4410 Red Ribbon	R4410R	18704
R4410 White Ribbon	R4410W	18705
R4410 Blue Ribbon	R4410B	18706
Soft Side User's Case	TLS2200-SC	18562
User's Guide	TLS2200-UM	18557

Appendix 1: Troubleshooting and Error Message Guide

If your TLS2200™ printer is not performing as documented in this user's guide, use the following troubleshooting and error message guides to determine the corrective action you should take. If the corrective action does not work, contact Brady's Technical Support Group.

Troubleshooting Guide

Symptom	Cause	Corrective Action
Poor quality printing.	Incorrect marker material/ribbon combination.	Verify the correct ribbon for the marker roll is loaded in the printer. Refer to the Ribbon Cross Reference Guide chart that came with the TLS2200 printer for proper ribbon selection.
Printer does not power up when turned on.	Battery pack is not charged.	<ol style="list-style-type: none"> 1. Connect the battery charger to the battery pack. 2. Charge the battery pack for at least five hours before operating solely on battery power.
	Battery pack may be worn out.	Battery life is approximately one to three years depending on its use and care. Order a replacement battery pack. Refer to page 1 for information on disposal of the battery pack.
Printer will not feed labels.	The marker roll has been fed through the material guide slots before the print head has been closed.	<ol style="list-style-type: none"> 1. Unlock the ribbon cartridge locking lever to open the print head, then remove the marker material from the material guide slots. 2. Close the print head by locking the ribbon cartridge lever 3. Feed the markers through the material guide slots.
	The leading edge of the marker roll is not inserted all the way to the drive roller.	Feed the leading edge of the marker roll through the material guide slots until you meet resistance.
	The leading edge of the marker roll is uneven or torn (not a straight edge).	Use a pair of scissors to cut a straight leading edge on the marker roll.

Symptom	Cause	Corrective Action
Top of the marker is cut through when cutting PSPT markers.	The movable material guide is not fully locked in place.	Verify the movable material guide is fully locked into the proper notch in the guide plate.

Error Messages

Error Message	Cause	Corrective Action
Error in Checksum	The software was improperly installed on your TLS2200™ printer.	Contact Brady's Technical Support Group.
Error Head Open	Print head is unlocked.	<ol style="list-style-type: none"> 1. Move the lever on the right side of the TLS2200 printer to the lock position. 2. Press the <Enter> or <Delete> button to clear the display.
Error No Label Present	The TLS2200 printer is not seeing the marker's smart cell located on the side of the marker roll.	<ol style="list-style-type: none"> 1. Verify the smart cell is making contact with the left material guide. 2. Be sure the right material guide is adjusted as far to the left as possible for the roll of markers used. The material guide should be locked into the proper notch in the guide plate. 3. Be sure the marker roll is snapped evenly and firmly in the label roll cradle. 4. Press the <Enter> or <Delete> button to clear the display.
Error Out of Label	The roll of markers is inserted properly in the material guides, however, they are either not feeding properly or the roll has run out of markers.	<ol style="list-style-type: none"> 1. Press the <Enter> or <Delete> button to clear the display. 2. Install a new marker roll if the roll has run out. <p>If:</p> <ul style="list-style-type: none"> • you have not run out of markers, the markers are not feeding properly. Be sure to insert the leading edge of the markers into the material path until they hit the feed roller. Be sure the leading edge of the marker is straight. If not, cut the edge with a pair of scissors. • the markers are present and printing, they may have become skewed or jammed. To fix, press the <Feed> key to recalibrate or open the print head and pull the markers through to clear the jam.

Error Message	Cause	Corrective Action
Head Too Hot	Print head cannot reliably print due to heat buildup.	<ol style="list-style-type: none"> 1. Press the <Enter> or <Delete> button to clear the display. 2. Allow the printer to cool for ten minutes before printing labels.
Invalid Label	The marker roll may be running through the printer twice.	The smart cell is programmed to run 125% of the total number of markers on the roll and then stop. Insert a new marker roll and continue.
	Smart cell may not be programmed properly.	Contact Brady's Technical Support Group.
Lithium Cell Low	Memory backup battery is low.	Contact Brady's Technical Support Group.
Low Battery	Battery pack is not charged.	<ol style="list-style-type: none"> 1. Connect the battery charger to the battery pack. 2. Charge the battery pack for at least five hours before operating solely on battery power.
	Battery pack may be worn out.	Battery life is approximately one to three years depending on its use and care. Order a replacement battery pack. Refer to page 1 for information on disposal of the battery pack.
Out of Ribbon	The ribbon has run out.	Change the ribbon.
	The ribbon is folded or mangled due to improper installation or label jam.	<ol style="list-style-type: none"> 1. Remove the ribbon. 2. Manually advance the take-up spool end towards you until the ribbon has a smooth, flat surface. 3. Reinsert the ribbon in the printer.
	There is a bad ribbon sensor.	Contact Brady's Technical Support Group.
Reduce Type Size	If you receive this message while typing, the line is full.	Press <Shift> + <?> to reduce the font size to add more characters to the line.

Error Message	Cause	Corrective Action
	<p>If you receive this message when you press <print>, you have exceeded the marker height. This occurs when font sizes are increased between lines of text, or you have chosen a bar code height that is too tall.</p>	<p>Reduce the font size or bar code height and press <print> again.</p>
Memory Full	<p>If you receive this message when trying to create a list, there are ten lists (the maximum) already saved in memory, or the memory has reached capacity.</p>	<p>Delete one or more lists.</p>
	<p>If you receive this message while trying to save a legend to a list, the memory has reached capacity.</p>	<p>Delete one or more lists or legends.</p>
Wrong Part! Use PTL-XX-XXX	<p>If you receive this message while trying to select a list, and Edit mode is off, either:</p> <ul style="list-style-type: none"> •there is no part loaded in the printer. -or- •you have the wrong part loaded in the printer. <p>The wrong part is a part other than the one the list was created for.</p>	<p>Load the correct part in the printer. The correct part is the part that the list was created for.</p>

Error Message	Cause	Corrective Action
	<p>If you receive this message while trying to save a legend to an active list, either:</p> <ul style="list-style-type: none"> •there is no part loaded in the printer. <p>-or-</p> <ul style="list-style-type: none"> •you have the wrong part loaded in the printer. <p>The wrong part is a part other than the one the list was created for.</p>	<p>Load the correct part in the printer. The correct part is the part that the list was created for.</p>

 **Note:** The error message “Invalid Function” may appear while you are working with legend lists. See Legend Lists on page 30 for details on working with lists. This error message may have different causes depending on what you are trying to do. The following table lists the different causes for this message as well as corrective action for each.

Error Message	Cause	Corrective Action
Invalid Function	If you receive this message while trying to enter Edit mode, you do not have a saved list.	Create a list. See Legend Lists on page 30 for instructions.
	If you receive this message while trying to print, you are in Edit mode.	Turn Edit mode <i>off</i> . See Legend Lists on page 30 for instructions.
	If you receive this message while trying to print and you are NOT in Edit mode, you do not have an active list.	Create or activate a list. See Legend Lists on page 30 for instructions.
	If you receive this message while trying to create a list, you are in Edit mode.	Turn Edit mode <i>off</i> . See Legend Lists on page 30 for instructions.
	If you receive this message while trying to delete a legend, you do not have a recalled legend.	Recall the legend that you want to delete. See Legend Lists on page 30 for instructions.
	If you receive this message while trying to save a legend to a list, you do not have an active list.	Create or activate a list. See Legend Lists on page 30 for instructions.

Appendix 2: Glossary of Terms

It may be helpful to review these terms while using this guide:

Active Legend List— A list becomes active when you create or select it. See *Creating a New List* and *Selecting a List* later in this section. A list that has been activated is ready to be printed or edited.

Label—Once a marker contains printed text, it is referred to as a label.

Legend—The actual text to be printed on a marker. The legend appears on the LCD screen and can be stored in memory.

Legend List—One or more legends stored under a list name.

Marker—A blank label. Until a label is actually printed, the material is referred to as a marker. Markers are available in a variety of sizes.

Marker Roll—A marker roll contains the marker and a notched liner which are fed through the printer, and a smart cell located in the spindle. The TLS2200™ printer uses the smart cell to automatically identify the marker being used.

Recalled Legend— A legend is recalled when you press <Func>+<Recall> or <Func>+<Shift>+<Recall> from within an active legend list.

Serialize—To automatically print labels in a numeric or alphabetical sequence.

Appendix 3: Using the TLS2200™ Program Installer

Use the TLS2200 Program Installer to install new software on your TLS2200 printer using your personal computer. This installer uses a wizard interface to simplify the installation process.

System Requirements

To use the TLS2200 Program Installer, you need a PC with the following:

- Windows 95, 98, or NT4.0 or higher with Service Pack 3
- 16 M of RAM
- 10 M of hard drive space
- One unused serial port
- 3.5" floppy drive (if installing from disk)
- Internet connection (if installing from the Internet)

In addition, you need the communications cable that connects the TLS2200 printer to your PC. This cable is available from Brady. See the Accessory Parts List on page 70.

Installing the TLS2200™ Program Installer from the Internet



Note: The TLS2200 Program Installer is available either from the Brady Internet website or on floppy disks. The installation procedure outlined below is for individuals that have downloaded the installer from the Brady Internet website. *Refer to the section Installing the TLS2200™ Program Installer from Disk if you purchased the Program Installer on disks.*

Complete the following steps to install the Installer on your PC from the file available on the Brady Internet website:

1. Log on to the Brady website at www.tls2200.com.
2. Go to the download area and click on the file you wish to download.
3. Select a folder on your hard drive in which to place the downloaded file and click OK. It may take a few minutes to download the file from Brady, depending on the speed of your PC's modem.

4. Click **Start** and then **Run**.

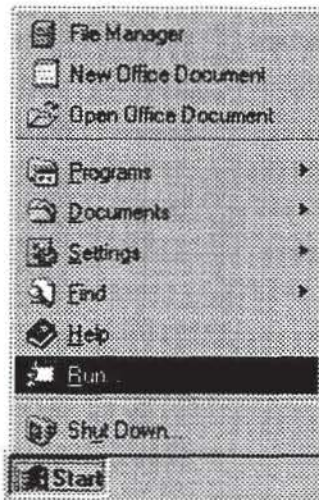

5. Type **C:\<Folder>\Setup.exe** in the Run dialog box where <Folder> is the name of the folder in which you placed the downloaded file.

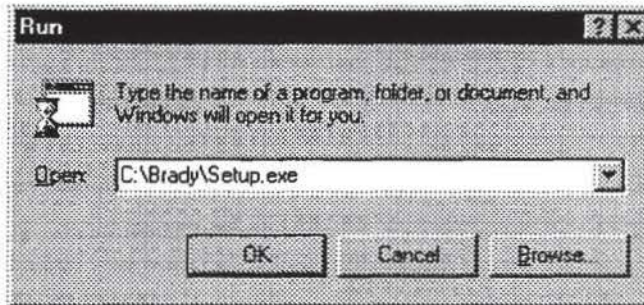

6. Proceed through the installation program, answering the questions as needed. In most cases, the default answer will suffice.
7. Restart your PC before continuing.

Installing the TLS2200™ Program Installer from Disk

 **Note:** The TLS2200 Program Installer is available either from the Brady Internet website or on floppy disks. The installation procedure outlined below is for individuals that have ordered the installer on disk. *Refer to the section Installing the TLS2200™ Program Installer from the Internet if you plan to download Program Installer from the Internet.*

Complete the following steps to install the Installer on your PC from 3.5" disks:

1. Insert disk #1 in your floppy drive.

2. Click **Start** and then **Run**.



3. Type **A:\Setup.exe** in the Run dialog box.

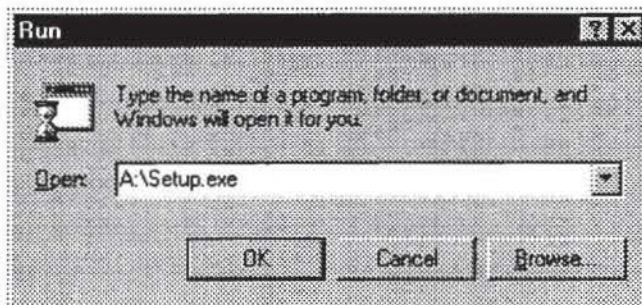

4. Proceed through the installation program, answering the questions as needed. In most cases, the default answer will suffice.
5. Insert disks #2 and #3 when prompted.
6. Restart your PC before continuing.

Connecting the TLS2200™ Printer to a PC

Complete the following steps to connect the TLS2200 printer to a PC:

1. Locate the communication port on the bottom of your TLS2200 printer. This is the port that looks similar to a modular phone jack and is found on the bottom of the printer.

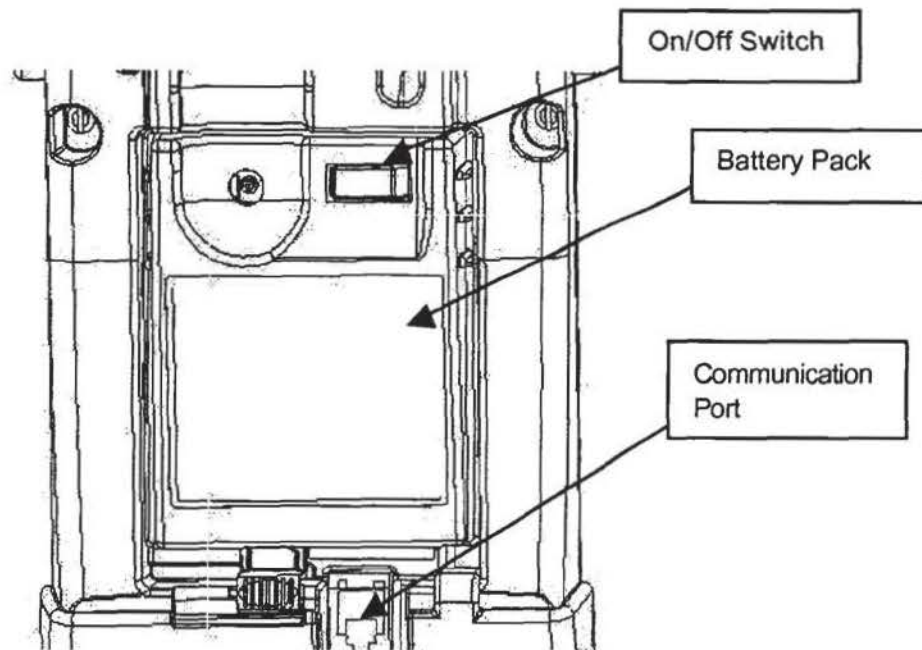

2. Plug the communications cable into the communications port and set the TLS2200 printer next to your PC.
3. Locate an unused serial port on the back of your PC. This port looks similar to the diagram below.

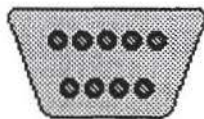

Serial Port



Note: If you have a 25-pin serial port instead of a 9-pin port, you should purchase an adapter from a computer parts supplier.

4. Plug the free end of the communications cable into the serial port and tighten the screws.

You have completed attaching the TLS2200™ printer to your PC and are now ready to begin installing the software.

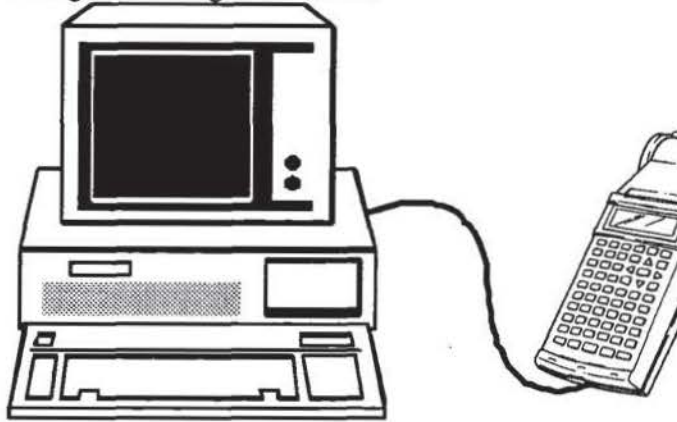

TLS2200 Printer Connected to a PC

Running the TLS2200™ Program Installer

Complete the following steps to run the TLS2200 Program Installer:

1. Click **Start** → **Programs** → **TLS2200 Installer** → **TLS2200**.

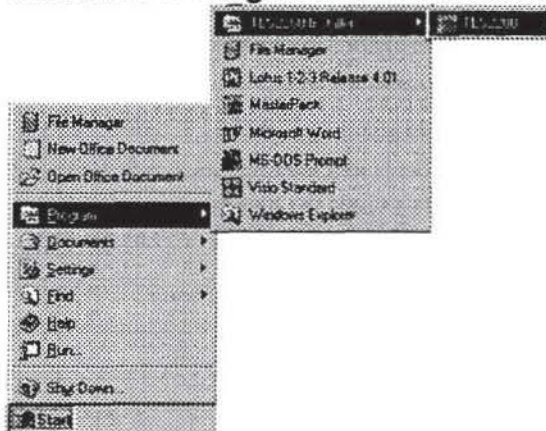

2. Once you see the TLS2200 Program Installer Introduction Screen, click **Help** to get the latest step-by-step instructions for using the wizard.

Future Installations

In the future you may receive TLS2200™ upgrade files either from the Brady Internet web site or on a 3.5" disk. The extension for these files is .hex. Use the TLS2200 Program Installer to install these files on your TLS2200 printer. Each time you receive a new .hex file, repeat the above procedure beginning with *Connecting the TLS2200 Printer to a PC*. Once you are in the wizard, you will be asked which .hex file you wish to install on your TLS2200 printer. Click **Change Program** and use the Select Program File dialog box to

select the new .hex file to be installed.



Note: Brady suggests you create a folder on your hard drive in which to store your .hex files. This will help you locate a .hex file in the future should the need arise.

Appendix 4: Direct Printing from LabelMark/Win

Use the LabelMark/WIN software to print labels from a PC through the TLS2200™ Thermal Transfer Printer. For more information on LabelMark/WIN software, please visit our website at www.bradyid.com.

Electronic Patent Application Fee Transmittal

Application Number:	13955345			
Filing Date:	31-Jul-2013			
Title of Invention:	TEXT ENTRY METHOD AND DEVICE THEREFOR			
First Named Inventor/Applicant Name:	Matthew J. Bickerton			
Filer:	Michael E. Belk/Elissa DeLuccy			
Attorney Docket Number:	2001P00413US01			
Filed as Large Entity				
Utility under 35 USC 111(a) Filing Fees				
Description	Fee Code	Quantity	Amount	Sub-Total in USD(\$)
Basic Filing:				
Pages:				
Claims:				
Miscellaneous-Filing:				
Petition:				
Patent-Appeals-and-Interference:				
Post-Allowance-and-Post-Issuance:				
Extension-of-Time:				

Description	Fee Code	Quantity	Amount	Sub-Total in USD(\$)
Miscellaneous:				
Request for Continued Examination	1801	1	1200	1200
Total in USD (\$)				1200

Electronic Acknowledgement Receipt

EFS ID:	18512509
Application Number:	13955345
International Application Number:	
Confirmation Number:	6652
Title of Invention:	TEXT ENTRY METHOD AND DEVICE THEREFOR
First Named Inventor/Applicant Name:	Matthew J. Bickerton
Customer Number:	24737
Filer:	Michael E. Belk/Elissa DeLuccy
Filer Authorized By:	Michael E. Belk
Attorney Docket Number:	2001P00413US01
Receipt Date:	18-MAR-2014
Filing Date:	31-JUL-2013
Time Stamp:	16:44:14
Application Type:	Utility under 35 USC 111(a)

Payment information:

Submitted with Payment	yes
Payment Type	Deposit Account
Payment was successfully received in RAM	\$1200
RAM confirmation Number	3815
Deposit Account	141270
Authorized User	

The Director of the USPTO is hereby authorized to charge indicated fees and credit any overpayment as follows:

Charge any Additional Fees required under 37 C.F.R. Section 1.16 (National application filing, search, and examination fees)

Charge any Additional Fees required under 37 C.F.R. Section 1.17 (Patent application and reexamination processing fees)

Charge any Additional Fees required under 37 C.F.R. Section 1.19 (Document supply fees)

Charge any Additional Fees required under 37 C.F.R. Section 1.21 (Miscellaneous fees and charges)

File Listing:

Document Number	Document Description	File Name	File Size(Bytes)/ Message Digest	Multi Part /.zip	Pages (if appl.)
1	Request for Continued Examination (RCE)	2001P00413US01_RCE.pdf	697792	no	3
			d5d5b54ba4b3c88a6d88948dd09ca77504c330a		
Warnings:					
Information:					
2	Information Disclosure Statement (IDS) Form (SB08)	2001P00413US01_IDS.pdf	613036	no	5
			bde18b4bccc62613282a9808b34f37a62b050e6		
Warnings:					
Information:					
3	Foreign Reference	JP4019512.pdf	1119237	no	39
			81081652d266ee219a5c3f1dd63cdf2724c6a44		
Warnings:					
Information:					
4	Foreign Reference	JP9034891A.pdf	1919986	no	48
			34ba24ec6637158444c6bbf001062c24585325		
Warnings:					
Information:					
5	Foreign Reference	JP2000172417A.pdf	2042757	no	36
			b3a236ae9b527ad06925a99391e43b58990994		
Warnings:					
Information:					
6	Foreign Reference	JP2001125720A.pdf	3402681	no	30
			e606b1a425ceaaf021945673b56be5b0f2c3fe4		
Warnings:					
Information:					
7	Non Patent Literature	An_Efficient_Text_Input.pdf	340272	no	8
			dfbdef775313c258c5772154af07e578ae22057		
Warnings:					
Information:					
8	Non Patent Literature	Users_Guide.pdf	1106662	no	93
			8d81f3da1a6b771ff2880dc99ffad77ce708ab02		
Warnings:					

Information:					
9	Fee Worksheet (SB06)	fee-info.pdf	30535	no	2
			(7b1e700479069000ee8ef8f58f39b395b87308c7		
Warnings:					
Information:					
Total Files Size (in bytes):				11272958	
<p>This Acknowledgement Receipt evidences receipt on the noted date by the USPTO of the indicated documents, characterized by the applicant, and including page counts, where applicable. It serves as evidence of receipt similar to a Post Card, as described in MPEP 503.</p> <p><u>New Applications Under 35 U.S.C. 111</u> If a new application is being filed and the application includes the necessary components for a filing date (see 37 CFR 1.53(b)-(d) and MPEP 506), a Filing Receipt (37 CFR 1.54) will be issued in due course and the date shown on this Acknowledgement Receipt will establish the filing date of the application.</p> <p><u>National Stage of an International Application under 35 U.S.C. 371</u> If a timely submission to enter the national stage of an international application is compliant with the conditions of 35 U.S.C. 371 and other applicable requirements a Form PCT/DO/EO/903 indicating acceptance of the application as a national stage submission under 35 U.S.C. 371 will be issued in addition to the Filing Receipt, in due course.</p> <p><u>New International Application Filed with the USPTO as a Receiving Office</u> If a new international application is being filed and the international application includes the necessary components for an international filing date (see PCT Article 11 and MPEP 1810), a Notification of the International Application Number and of the International Filing Date (Form PCT/RO/105) will be issued in due course, subject to prescriptions concerning national security, and the date shown on this Acknowledgement Receipt will establish the international filing date of the application.</p>					



UNITED STATES PATENT AND TRADEMARK OFFICE

UNITED STATES DEPARTMENT OF COMMERCE
United States Patent and Trademark Office
Address: COMMISSIONER FOR PATENTS
P.O. Box 1450
Alexandria, Virginia 22313-1450
www.uspto.gov

NOTICE OF ALLOWANCE AND FEE(S) DUE

24737 7590 03/28/2014
PHILIPS INTELLECTUAL PROPERTY & STANDARDS
P.O. BOX 3001
BRIARCLIFF MANOR, NY 10510

EXAMINER

WONG, ALBERT KANG

ART UNIT PAPER NUMBER

2689

DATE MAILED: 03/28/2014

Table with 5 columns: APPLICATION NO., FILING DATE, FIRST NAMED INVENTOR, ATTORNEY DOCKET NO., CONFIRMATION NO.
13/955,345 07/31/2013 Matthew J. Bickerton 2001P00413US01 6652

TITLE OF INVENTION: TEXT ENTRY METHOD AND DEVICE THEREFOR

Table with 7 columns: APPLN. TYPE, ENTITY STATUS, ISSUE FEE DUE, PUBLICATION FEE DUE, PREV. PAID ISSUE FEE, TOTAL FEE(S) DUE, DATE DUE
nonprovisional UNDISCOUNTED \$960 \$0 \$0 \$960 06/30/2014

THE APPLICATION IDENTIFIED ABOVE HAS BEEN EXAMINED AND IS ALLOWED FOR ISSUANCE AS A PATENT. PROSECUTION ON THE MERITS IS CLOSED. THIS NOTICE OF ALLOWANCE IS NOT A GRANT OF PATENT RIGHTS. THIS APPLICATION IS SUBJECT TO WITHDRAWAL FROM ISSUE AT THE INITIATIVE OF THE OFFICE OR UPON PETITION BY THE APPLICANT. SEE 37 CFR 1.313 AND MPEP 1308.

THE ISSUE FEE AND PUBLICATION FEE (IF REQUIRED) MUST BE PAID WITHIN THREE MONTHS FROM THE MAILING DATE OF THIS NOTICE OR THIS APPLICATION SHALL BE REGARDED AS ABANDONED. THIS STATUTORY PERIOD CANNOT BE EXTENDED. SEE 35 U.S.C. 151. THE ISSUE FEE DUE INDICATED ABOVE DOES NOT REFLECT A CREDIT FOR ANY PREVIOUSLY PAID ISSUE FEE IN THIS APPLICATION. IF AN ISSUE FEE HAS PREVIOUSLY BEEN PAID IN THIS APPLICATION (AS SHOWN ABOVE), THE RETURN OF PART B OF THIS FORM WILL BE CONSIDERED A REQUEST TO REAPPLY THE PREVIOUSLY PAID ISSUE FEE TOWARD THE ISSUE FEE NOW DUE.

HOW TO REPLY TO THIS NOTICE:

I. Review the ENTITY STATUS shown above. If the ENTITY STATUS is shown as SMALL or MICRO, verify whether entitlement to that entity status still applies.

If the ENTITY STATUS is the same as shown above, pay the TOTAL FEE(S) DUE shown above.

If the ENTITY STATUS is changed from that shown above, on PART B - FEE(S) TRANSMITTAL, complete section number 5 titled "Change in Entity Status (from status indicated above)".

For purposes of this notice, small entity fees are 1/2 the amount of undiscounted fees, and micro entity fees are 1/2 the amount of small entity fees.

II. PART B - FEE(S) TRANSMITTAL, or its equivalent, must be completed and returned to the United States Patent and Trademark Office (USPTO) with your ISSUE FEE and PUBLICATION FEE (if required). If you are charging the fee(s) to your deposit account, section "4b" of Part B - Fee(s) Transmittal should be completed and an extra copy of the form should be submitted. If an equivalent of Part B is filed, a request to reapply a previously paid issue fee must be clearly made, and delays in processing may occur due to the difficulty in recognizing the paper as an equivalent of Part B.

III. All communications regarding this application must give the application number. Please direct all communications prior to issuance to Mail Stop ISSUE FEE unless advised to the contrary.

IMPORTANT REMINDER: Utility patents issuing on applications filed on or after Dec. 12, 1980 may require payment of maintenance fees. It is patentee's responsibility to ensure timely payment of maintenance fees when due.

PART B - FEE(S) TRANSMITTAL

Complete and send this form, together with applicable fee(s), to: **Mail** Mail Stop ISSUE FEE
 Commissioner for Patents
 P.O. Box 1450
 Alexandria, Virginia 22313-1450
 or **Fax** (571)-273-2885

INSTRUCTIONS: This form should be used for transmitting the ISSUE FEE and PUBLICATION FEE (if required). Blocks 1 through 5 should be completed where appropriate. All further correspondence including the Patent, advance orders and notification of maintenance fees will be mailed to the current correspondence address as indicated unless corrected below or directed otherwise in Block 1, by (a) specifying a new correspondence address; and/or (b) indicating a separate "FEE ADDRESS" for maintenance fee notifications.

CURRENT CORRESPONDENCE ADDRESS (Note: Use Block 1 for any change of address)

24737 7590 03/28/2014
PHILIPS INTELLECTUAL PROPERTY & STANDARDS
 P.O. BOX 3001
 BRIARCLIFF MANOR, NY 10510

Note: A certificate of mailing can only be used for domestic mailings of the Fee(s) Transmittal. This certificate cannot be used for any other accompanying papers. Each additional paper, such as an assignment or formal drawing, must have its own certificate of mailing or transmission.

Certificate of Mailing or Transmission

I hereby certify that this Fee(s) Transmittal is being deposited with the United States Postal Service with sufficient postage for first class mail in an envelope addressed to the Mail Stop ISSUE FEE address above, or being facsimile transmitted to the USPTO (571) 273-2885, on the date indicated below.

(Depositor's name)
(Signature)
(Date)

APPLICATION NO.	FILING DATE	FIRST NAMED INVENTOR	ATTORNEY DOCKET NO.	CONFIRMATION NO.
13/955,345	07/31/2013	Matthew J. Bickerton	2001P00413US01	6652

TITLE OF INVENTION: TEXT ENTRY METHOD AND DEVICE THEREFOR

APPLN. TYPE	ENTITY STATUS	ISSUE FEE DUE	PUBLICATION FEE DUE	PREV. PAID ISSUE FEE	TOTAL FEE(S) DUE	DATE DUE
nonprovisional	UNDISCOUNTED	\$960	\$0	\$0	\$960	06/30/2014

EXAMINER	ART UNIT	CLASS-SUBCLASS
WONG, ALBERT KANG	2689	341-022000

<p>1. Change of correspondence address or indication of "Fee Address" (37 CFR 1.363).</p> <p><input type="checkbox"/> Change of correspondence address (or Change of Correspondence Address form PTO/SB/122) attached.</p> <p><input type="checkbox"/> "Fee Address" indication (or "Fee Address" Indication form PTO/SB/47; Rev 03-02 or more recent) attached. Use of a Customer Number is required.</p>	<p>2. For printing on the patent front page, list</p> <p>(1) The names of up to 3 registered patent attorneys or agents OR, alternatively,</p> <p>(2) The name of a single firm (having as a member a registered attorney or agent) and the names of up to 2 registered patent attorneys or agents. If no name is listed, no name will be printed.</p> <p>1 _____</p> <p>2 _____</p> <p>3 _____</p>
--	---

3. ASSIGNEE NAME AND RESIDENCE DATA TO BE PRINTED ON THE PATENT (print or type)

PLEASE NOTE: Unless an assignee is identified below, no assignee data will appear on the patent. If an assignee is identified below, the document has been filed for recordation as set forth in 37 CFR 3.11. Completion of this form is NOT a substitute for filing an assignment.

(A) NAME OF ASSIGNEE _____ (B) RESIDENCE: (CITY and STATE OR COUNTRY) _____

Please check the appropriate assignee category or categories (will not be printed on the patent): Individual Corporation or other private group entity Government

<p>4a. The following fee(s) are submitted:</p> <p><input type="checkbox"/> Issue Fee</p> <p><input type="checkbox"/> Publication Fee (No small entity discount permitted)</p> <p><input type="checkbox"/> Advance Order - # of Copies _____</p>	<p>4b. Payment of Fee(s): (Please first reapply any previously paid issue fee shown above)</p> <p><input type="checkbox"/> A check is enclosed.</p> <p><input type="checkbox"/> Payment by credit card. Form PTO-2038 is attached.</p> <p><input type="checkbox"/> The Director is hereby authorized to charge the required fee(s), any deficiency, or credits any overpayment, to Deposit Account Number _____ (enclose an extra copy of this form).</p>
---	---

<p>5. Change in Entity Status (from status indicated above)</p> <p><input type="checkbox"/> Applicant certifying micro entity status. See 37 CFR 1.29</p> <p><input type="checkbox"/> Applicant asserting small entity status. See 37 CFR 1.27</p> <p><input type="checkbox"/> Applicant changing to regular undiscounted fee status.</p>	<p>NOTE: Absent a valid certification of Micro Entity Status (see forms PTO/SB/15A and 15B), issue fee payment in the micro entity amount will not be accepted at the risk of application abandonment.</p> <p>NOTE: If the application was previously under micro entity status, checking this box will be taken to be a notification of loss of entitlement to micro entity status.</p> <p>NOTE: Checking this box will be taken to be a notification of loss of entitlement to small or micro entity status, as applicable.</p>
---	--

NOTE: This form must be signed in accordance with 37 CFR 1.31 and 1.33. See 37 CFR 1.4 for signature requirements and certifications.

Authorized Signature _____ Date _____

Typed or printed name _____ Registration No. _____



UNITED STATES PATENT AND TRADEMARK OFFICE

UNITED STATES DEPARTMENT OF COMMERCE
United States Patent and Trademark Office
Address: COMMISSIONER FOR PATENTS
P.O. Box 1450
Alexandria, Virginia 22313-1450
www.uspto.gov

Table with 5 columns: APPLICATION NO., FILING DATE, FIRST NAMED INVENTOR, ATTORNEY DOCKET NO., CONFIRMATION NO.
13/955,345 07/31/2013 Matthew J. Bickerton 2001P00413US01 6652

24737 7590 03/28/2014
PHILIPS INTELLECTUAL PROPERTY & STANDARDS
P.O. BOX 3001
BRIARCLIFF MANOR, NY 10510

EXAMINER

WONG, ALBERT KANG

ART UNIT PAPER NUMBER

2689

DATE MAILED: 03/28/2014

Determination of Patent Term Extension or Adjustment under 35 U.S.C. 154 (b)

A reissue patent is for "the unexpired part of the term of the original patent." See 35 U.S.C. 251. Accordingly, the above-identified reissue application is not eligible for Patent Term Extension or Adjustment under 35 U.S.C. 154(b).

Any questions regarding the Patent Term Extension or Adjustment determination should be directed to the Office of Patent Legal Administration at (571)-272-7702. Questions relating to issue and publication fee payments should be directed to the Customer Service Center of the Office of Patent Publication at 1-(888)-786-0101 or (571)-272-4200.

OMB Clearance and PRA Burden Statement for PTOL-85 Part B

The Paperwork Reduction Act (PRA) of 1995 requires Federal agencies to obtain Office of Management and Budget approval before requesting most types of information from the public. When OMB approves an agency request to collect information from the public, OMB (i) provides a valid OMB Control Number and expiration date for the agency to display on the instrument that will be used to collect the information and (ii) requires the agency to inform the public about the OMB Control Number's legal significance in accordance with 5 CFR 1320.5(b).

The information collected by PTOL-85 Part B is required by 37 CFR 1.311. The information is required to obtain or retain a benefit by the public which is to file (and by the USPTO to process) an application. Confidentiality is governed by 35 U.S.C. 122 and 37 CFR 1.14. This collection is estimated to take 12 minutes to complete, including gathering, preparing, and submitting the completed application form to the USPTO. Time will vary depending upon the individual case. Any comments on the amount of time you require to complete this form and/or suggestions for reducing this burden, should be sent to the Chief Information Officer, U.S. Patent and Trademark Office, U.S. Department of Commerce, P.O. Box 1450, Alexandria, Virginia 22313-1450. DO NOT SEND FEES OR COMPLETED FORMS TO THIS ADDRESS. SEND TO: Commissioner for Patents, P.O. Box 1450, Alexandria, Virginia 22313-1450. Under the Paperwork Reduction Act of 1995, no persons are required to respond to a collection of information unless it displays a valid OMB control number.

Privacy Act Statement

The Privacy Act of 1974 (P.L. 93-579) requires that you be given certain information in connection with your submission of the attached form related to a patent application or patent. Accordingly, pursuant to the requirements of the Act, please be advised that: (1) the general authority for the collection of this information is 35 U.S.C. 2(b)(2); (2) furnishing of the information solicited is voluntary; and (3) the principal purpose for which the information is used by the U.S. Patent and Trademark Office is to process and/or examine your submission related to a patent application or patent. If you do not furnish the requested information, the U.S. Patent and Trademark Office may not be able to process and/or examine your submission, which may result in termination of proceedings or abandonment of the application or expiration of the patent.

The information provided by you in this form will be subject to the following routine uses:

1. The information on this form will be treated confidentially to the extent allowed under the Freedom of Information Act (5 U.S.C. 552) and the Privacy Act (5 U.S.C. 552a). Records from this system of records may be disclosed to the Department of Justice to determine whether disclosure of these records is required by the Freedom of Information Act.
2. A record from this system of records may be disclosed, as a routine use, in the course of presenting evidence to a court, magistrate, or administrative tribunal, including disclosures to opposing counsel in the course of settlement negotiations.
3. A record in this system of records may be disclosed, as a routine use, to a Member of Congress submitting a request involving an individual, to whom the record pertains, when the individual has requested assistance from the Member with respect to the subject matter of the record.
4. A record in this system of records may be disclosed, as a routine use, to a contractor of the Agency having need for the information in order to perform a contract. Recipients of information shall be required to comply with the requirements of the Privacy Act of 1974, as amended, pursuant to 5 U.S.C. 552a(m).
5. A record related to an International Application filed under the Patent Cooperation Treaty in this system of records may be disclosed, as a routine use, to the International Bureau of the World Intellectual Property Organization, pursuant to the Patent Cooperation Treaty.
6. A record in this system of records may be disclosed, as a routine use, to another federal agency for purposes of National Security review (35 U.S.C. 181) and for review pursuant to the Atomic Energy Act (42 U.S.C. 218(c)).
7. A record from this system of records may be disclosed, as a routine use, to the Administrator, General Services, or his/her designee, during an inspection of records conducted by GSA as part of that agency's responsibility to recommend improvements in records management practices and programs, under authority of 44 U.S.C. 2904 and 2906. Such disclosure shall be made in accordance with the GSA regulations governing inspection of records for this purpose, and any other relevant (i.e., GSA or Commerce) directive. Such disclosure shall not be used to make determinations about individuals.
8. A record from this system of records may be disclosed, as a routine use, to the public after either publication of the application pursuant to 35 U.S.C. 122(b) or issuance of a patent pursuant to 35 U.S.C. 151. Further, a record may be disclosed, subject to the limitations of 37 CFR 1.14, as a routine use, to the public if the record was filed in an application which became abandoned or in which the proceedings were terminated and which application is referenced by either a published application, an application open to public inspection or an issued patent.
9. A record from this system of records may be disclosed, as a routine use, to a Federal, State, or local law enforcement agency, if the USPTO becomes aware of a violation or potential violation of law or regulation.

Notice of Allowability	Application No. 13/955,345	Applicant(s) BICKERTON, MATTHEW J.	
	Examiner ALBERT WONG	Art Unit 2689	AIA (First Inventor to File) Status No

-- The MAILING DATE of this communication appears on the cover sheet with the correspondence address--

All claims being allowable, PROSECUTION ON THE MERITS IS (OR REMAINS) CLOSED in this application. If not included herewith (or previously mailed), a Notice of Allowance (PTOL-85) or other appropriate communication will be mailed in due course. **THIS NOTICE OF ALLOWABILITY IS NOT A GRANT OF PATENT RIGHTS.** This application is subject to withdrawal from issue at the initiative of the Office or upon petition by the applicant. See 37 CFR 1.313 and MPEP 1308.

1. This communication is responsive to the papers filed 3/18/14.
 A declaration(s)/affidavit(s) under 37 CFR 1.130(b) was/were filed on _____.
2. An election was made by the applicant in response to a restriction requirement set forth during the interview on _____; the restriction requirement and election have been incorporated into this action.
3. The allowed claim(s) is/are 1-16. As a result of the allowed claim(s), you may be eligible to benefit from the **Patent Prosecution Highway** program at a participating intellectual property office for the corresponding application. For more information, please see http://www.uspto.gov/patents/init_events/pph/index.jsp or send an inquiry to PPHfeedback@uspto.gov.
4. Acknowledgment is made of a claim for foreign priority under 35 U.S.C. § 119(a)-(d) or (f).

Certified copies:

- a) All b) Some *c) None of the:
1. Certified copies of the priority documents have been received.
 2. Certified copies of the priority documents have been received in Application No. _____.
 3. Copies of the certified copies of the priority documents have been received in this national stage application from the International Bureau (PCT Rule 17.2(a)).

* Certified copies not received: _____.

Applicant has **THREE MONTHS FROM THE "MAILING DATE"** of this communication to file a reply complying with the requirements noted below. Failure to timely comply will result in **ABANDONMENT** of this application.
THIS THREE-MONTH PERIOD IS NOT EXTENDABLE.

5. **CORRECTED DRAWINGS** (as "replacement sheets") must be submitted.
 including changes required by the attached Examiner's Amendment / Comment or in the Office action of Paper No./Mail Date _____.
Identifying indicia such as the application number (see 37 CFR 1.84(c)) should be written on the drawings in the front (not the back) of each sheet. Replacement sheet(s) should be labeled as such in the header according to 37 CFR 1.121(d).
6. **DEPOSIT OF and/or INFORMATION** about the deposit of **BIOLOGICAL MATERIAL** must be submitted. Note the attached Examiner's comment regarding **REQUIREMENT FOR THE DEPOSIT OF BIOLOGICAL MATERIAL.**

Attachment(s)

- | | |
|--|--|
| 1. <input type="checkbox"/> Notice of References Cited (PTO-892) | 5. <input type="checkbox"/> Examiner's Amendment/Comment |
| 2. <input checked="" type="checkbox"/> Information Disclosure Statements (PTO/SB/08),
Paper No./Mail Date _____ | 6. <input checked="" type="checkbox"/> Examiner's Statement of Reasons for Allowance |
| 3. <input type="checkbox"/> Examiner's Comment Regarding Requirement for Deposit
of Biological Material | 7. <input type="checkbox"/> Other _____. |
| 4. <input type="checkbox"/> Interview Summary (PTO-413),
Paper No./Mail Date _____. | |

--	--

Art Unit: 2689

1. The present application is being examined under the pre-AIA first to invent provisions. This Office action is in response to the RCE and IDS filed March 18, 2014. The claims are not amended. The references cited have been considered. It has been determined that the cited references do not affect the prior reason for allowance of the claims.

2. Claims 1-16 are allowed.

3. Any inquiry concerning this communication or earlier communications from the examiner should be directed to ALBERT WONG whose telephone number is (571)272-3057. The examiner can normally be reached on M-Th.

If attempts to reach the examiner by telephone are unsuccessful, the examiner's supervisor, Jennifer Mehmood can be reached on 571-272-2976. The fax phone number for the organization where this application or proceeding is assigned is 571-273-8300.

Information regarding the status of an application may be obtained from the Patent Application Information Retrieval (PAIR) system. Status information for published applications may be obtained from either Private PAIR or Public PAIR. Status information for unpublished applications is available through Private PAIR only. For more information about the PAIR system, see <http://pair-direct.uspto.gov>. Should you have questions on access to the Private PAIR system, contact the Electronic Business Center (EBC) at 866-217-9197 (toll-free). If you would like assistance from a USPTO Customer Service Representative or access to the automated information system, call 800-786-9199 (IN USA OR CANADA) or 571-272-1000.

/ALBERT WONG/
Primary Examiner, Art Unit 2689

March 20, 2014

Application/Control Number: 13/955,345
Art Unit: 2689

Page 3

INFORMATION DISCLOSURE STATEMENT BY APPLICANT (Not for submission under 37 CFR 1.99)	Application Number		13955345
	Filing Date		2013-07-31
	First Named Inventor	Matthew J. Bickerton	
	Art Unit	2689	
	Examiner Name	Albert Kang Wong	
	Attorney Docket Number	2001P00413US01	

U.S. PATENTS						Remove
Examiner Initial*	Cite No	Patent Number	Kind Code ¹	Issue Date	Name of Patentee or Applicant of cited Document	Pages, Columns, Lines where Relevant Passages or Relevant Figures Appear
	1	5798716	A	1998-08-25	DAVIS	
	2	6043760	A	2000-03-28	LAAKKONEN	
	3	6130628	A	2000-10-10	SCHNEIDER-HUFSCHMIDT ET AL	
	4	6295052	B1	2001-09-25	KATO ET AL	
	5	5956021	A	1999-09-21	KUBOTA ET AL	
	6	6686902	A1	2002-04-11	LEE	
	7	5861823	A	1999-01-19	STRAUCH ET AL	
	8	6271835	B1	2001-08-07	HOEKSMAS	

**INFORMATION DISCLOSURE
STATEMENT BY APPLICANT**
(Not for submission under 37 CFR 1.99)

Application Number	13955345
Filing Date	2013-07-31
First Named Inventor	Matthew J. Bickerton
Art Unit	2689
Examiner Name	Albert Kang Wong
Attorney Docket Number	2001P00413US01

9	6016142	A	2000-01-18	CHANG ET AL	
---	---------	---	------------	-------------	--

If you wish to add additional U.S. Patent citation information please click the Add button. Add

U.S.PATENT APPLICATION PUBLICATIONS Remove

Examiner Initial*	Cite No	Publication Number	Kind Code ¹	Publication Date	Name of Patentee or Applicant of cited Document	Pages, Columns, Lines where Relevant Passages or Relevant Figures Appear
	1					

If you wish to add additional U.S. Published Application citation information please click the Add button. Add

FOREIGN PATENT DOCUMENTS Remove

Examiner Initial*	Cite No	Foreign Document Number ³	Country Code ² i	Kind Code ⁴	Publication Date	Name of Patentee or Applicant of cited Document	Pages, Columns, Lines where Relevant Passages or Relevant Figures Appear	T ⁵
	1	2001125720	JP	A	2001-05-11	NI ET AL		<input checked="" type="checkbox"/>
	2	0934891	JP	A	1997-02-07	ENDO		<input checked="" type="checkbox"/>
	3	2000172417	JP	A	2000-06-23	URITA		<input checked="" type="checkbox"/>
	4	4019512	JP	A	2007-10-05	SAKATA		<input checked="" type="checkbox"/>

If you wish to add additional Foreign Patent Document citation information please click the Add button. Add

NON-PATENT LITERATURE DOCUMENTS Remove

Examiner Initials*	Cite No	Include name of the author (in CAPITAL LETTERS), title of the article (when appropriate), title of the item (book, magazine, journal, serial, symposium, catalog, etc), date, pages(s), volume-issue number(s), publisher, city and/or country where published.	T ⁵

INFORMATION DISCLOSURE STATEMENT BY APPLICANT (Not for submission under 37 CFR 1.99)	Application Number	13955345
	Filing Date	2013-07-31
	First Named Inventor	Matthew J. Bickerton
	Art Unit	2689
	Examiner Name	Albert Kang Wong
	Attorney Docket Number	2001P00413US01

1	TLS2200 THERMAL TRANSFER PRINTER USER'S GUIDE, 2000 BRADY WORLDWIDE, INC. 93 PAGES	<input type="checkbox"/>
2	MASUI, "AN EFFICIENT TEXT INPUT METHOD FOR PEN-BASED COMPUTERS", PROCEEDINGS OF THE ACM CONFERENCE ON HUMAN FACTORS IN COMPUTING SYSTEM, APRIL 1998, PAGES 328-335	<input type="checkbox"/>

If you wish to add additional non-patent literature document citation information please click the Add button **Add**

EXAMINER SIGNATURE

Examiner Signature	/Albert Wong/ (03/20/2014)	Date Considered
--------------------	----------------------------	-----------------

*EXAMINER: Initial if reference considered, whether or not citation is in conformance with MPEP 609. Draw line through a citation if not in conformance and not considered. Include copy of this form with next communication to applicant.

¹ See Kind Codes of USPTO Patent Documents at www.USPTO.GOV or MPEP 901.04. ² Enter office that issued the document, by the two-letter code (WIPO Standard ST.3). ³ For Japanese patent documents, the indication of the year of the reign of the Emperor must precede the serial number of the patent document. ⁴ Kind of document by the appropriate symbols as indicated on the document under WIPO Standard ST.16 if possible. ⁵ Applicant is to place a check mark here if English language translation is attached.

**INFORMATION DISCLOSURE
STATEMENT BY APPLICANT**
(Not for submission under 37 CFR 1.99)

Application Number	13955345
Filing Date	2013-07-31
First Named Inventor	Matthew J. Bickerton
Art Unit	2689
Examiner Name	Albert Kang Wong
Attorney Docket Number	2001P00413US01

CERTIFICATION STATEMENT

Please see 37 CFR 1.97 and 1.98 to make the appropriate selection(s):

That each item of information contained in the information disclosure statement was first cited in any communication from a foreign patent office in a counterpart foreign application not more than three months prior to the filing of the information disclosure statement. See 37 CFR 1.97(e)(1).

OR

That no item of information contained in the information disclosure statement was cited in a communication from a foreign patent office in a counterpart foreign application, and, to the knowledge of the person signing the certification after making reasonable inquiry, no item of information contained in the information disclosure statement was known to any individual designated in 37 CFR 1.56(c) more than three months prior to the filing of the information disclosure statement. See 37 CFR 1.97(e)(2).

- See attached certification statement.
 Fee set forth in 37 CFR 1.17 (p) has been submitted herewith.
 None

SIGNATURE

A signature of the applicant or representative is required in accordance with CFR 1.33, 10.18. Please see CFR 1.4(d) for the form of the signature.

Signature	/Michael E. Belk/	Date (YYYY-MM-DD)	2014-03-18
Name/Print	Michael E. Belk	Registration Number	33,357

This collection of information is required by 37 CFR 1.97 and 1.98. The information is required to obtain or retain a benefit by the public which is to file (and by the USPTO to process) an application. Confidentiality is governed by 35 U.S.C. 122 and 37 CFR 1.14. This collection is estimated to take 1 hour to complete, including gathering, preparing and submitting the completed application form to the USPTO. Time will vary depending upon the individual case. Any comments on the amount of time you require to complete this form and/or suggestions for reducing this burden, should be sent to the Chief Information Officer, U.S. Patent and Trademark Office, U.S. Department of Commerce, P.O. Box 1450, Alexandria, VA 22313-1450. **DO NOT SEND FEES OR COMPLETED FORMS TO THIS ADDRESS. SEND TO: Commissioner for Patents, P.O. Box 1450, Alexandria, VA 22313-1450.**

Privacy Act Statement

The Privacy Act of 1974 (P.L. 93-579) requires that you be given certain information in connection with your submission of the attached form related to a patent application or patent. Accordingly, pursuant to the requirements of the Act, please be advised that: (1) the general authority for the collection of this information is 35 U.S.C. 2(b)(2); (2) furnishing of the information solicited is voluntary; and (3) the principal purpose for which the information is used by the U.S. Patent and Trademark Office is to process and/or examine your submission related to a patent application or patent. If you do not furnish the requested information, the U.S. Patent and Trademark Office may not be able to process and/or examine your submission, which may result in termination of proceedings or abandonment of the application or expiration of the patent.

The information provided by you in this form will be subject to the following routine uses:

1. The information on this form will be treated confidentially to the extent allowed under the Freedom of Information Act (5 U.S.C. 552) and the Privacy Act (5 U.S.C. 552a). Records from this system of records may be disclosed to the Department of Justice to determine whether the Freedom of Information Act requires disclosure of these records.
2. A record from this system of records may be disclosed, as a routine use, in the course of presenting evidence to a court, magistrate, or administrative tribunal, including disclosures to opposing counsel in the course of settlement negotiations.
3. A record in this system of records may be disclosed, as a routine use, to a Member of Congress submitting a request involving an individual, to whom the record pertains, when the individual has requested assistance from the Member with respect to the subject matter of the record.
4. A record in this system of records may be disclosed, as a routine use, to a contractor of the Agency having need for the information in order to perform a contract. Recipients of information shall be required to comply with the requirements of the Privacy Act of 1974, as amended, pursuant to 5 U.S.C. 552a(m).
5. A record related to an International Application filed under the Patent Cooperation Treaty in this system of records may be disclosed, as a routine use, to the International Bureau of the World Intellectual Property Organization, pursuant to the Patent Cooperation Treaty.
6. A record in this system of records may be disclosed, as a routine use, to another federal agency for purposes of National Security review (35 U.S.C. 181) and for review pursuant to the Atomic Energy Act (42 U.S.C. 218(c)).
7. A record from this system of records may be disclosed, as a routine use, to the Administrator, General Services, or his/her designee, during an inspection of records conducted by GSA as part of that agency's responsibility to recommend improvements in records management practices and programs, under authority of 44 U.S.C. 2904 and 2906. Such disclosure shall be made in accordance with the GSA regulations governing inspection of records for this purpose, and any other relevant (i.e., GSA or Commerce) directive. Such disclosure shall not be used to make determinations about individuals.
8. A record from this system of records may be disclosed, as a routine use, to the public after either publication of the application pursuant to 35 U.S.C. 122(b) or issuance of a patent pursuant to 35 U.S.C. 151. Further, a record may be disclosed, subject to the limitations of 37 CFR 1.14, as a routine use, to the public if the record was filed in an application which became abandoned or in which the proceedings were terminated and which application is referenced by either a published application, an application open to public inspections or an issued patent.
9. A record from this system of records may be disclosed, as a routine use, to a Federal, State, or local law enforcement agency, if the USPTO becomes aware of a violation or potential violation of law or regulation.

ALL REFERENCES CONSIDERED EXCEPT WHERE LINED THROUGH. /A.W./

Issue Classification 	Application/Control No. 13955345	Applicant(s)/Patent Under Reexamination BICKERTON, MATTHEW J.	
	Examiner ALBERT WONG	Art Unit 2689	

CPC				Type	Version
Symbol					

CPC Combination Sets				
Symbol	Type	Set	Ranking	Version

NONE		Total Claims Allowed:	
		16	
(Assistant Examiner)	(Date)	O.G. Print Claim(s)	O.G. Print Figure
/ALBERT WONG/ Primary Examiner. Art Unit 2689	03/20/2014	1	1
(Primary Examiner)	(Date)		

Issue Classification 	Application/Control No. 13955345	Applicant(s)/Patent Under Reexamination BICKERTON, MATTHEW J.
	Examiner ALBERT WONG	Art Unit 2689

US ORIGINAL CLASSIFICATION				INTERNATIONAL CLASSIFICATION							
CLASS		SUBCLASS		CLAIMED				NON-CLAIMED			
341		22		H	0	3	K	17 / 94 (2006.01.01)			
CROSS REFERENCE(S)				G	0	6	F	15 / 02 (2006.01.01)			
CLASS	SUBCLASS (ONE SUBCLASS PER BLOCK)										
345	188										
708	145	146									
379	368										
400	486										

NONE		Total Claims Allowed:	
		16	
(Assistant Examiner)	(Date)		
/ALBERT WONG/ Primary Examiner. Art Unit 2689	03/20/2014	O.G. Print Claim(s)	O.G. Print Figure
(Primary Examiner)	(Date)	1	1

Issue Classification 	Application/Control No. 13955345	Applicant(s)/Patent Under Reexamination BICKERTON, MATTHEW J.
	Examiner ALBERT WONG	Art Unit 2689

<input checked="" type="checkbox"/> Claims renumbered in the same order as presented by applicant																<input type="checkbox"/> CPA		<input type="checkbox"/> T.D.		<input type="checkbox"/> R.1.47	
Final	Original	Final	Original	Final	Original	Final	Original	Final	Original	Final	Original	Final	Original	Final	Original						
	1																				
	2																				
	3																				
	4																				
	5																				
	6																				
	7																				
	8																				
	9																				
	10																				
	11																				
	12																				
	13																				
	14																				
	15																				
	16																				

NONE		Total Claims Allowed:	
		16	
(Assistant Examiner)	(Date)	O.G. Print Claim(s)	O.G. Print Figure
/ALBERT WONG/ Primary Examiner, Art Unit 2689	03/20/2014	1	1
(Primary Examiner)	(Date)		

Search Notes 	Application/Control No. 13955345	Applicant(s)/Patent Under Reexamination BICKERTON, MATTHEW J.
	Examiner ALBERT WONG	Art Unit 2689

CPC- SEARCHED		
Symbol	Date	Examiner
h03k 17/94; g06f 15/02, 3/0238	2/3/14	AKW
	3/20/14	AKW

CPC COMBINATION SETS - SEARCHED		
Symbol	Date	Examiner

US CLASSIFICATION SEARCHED			
Class	Subclass	Date	Examiner
341	20, 22	2/3/14	AKW
345	168		
379	368		
400	486		
708	131, 145, 146		
search update		3/20/14	AKW

SEARCH NOTES		
Search Notes	Date	Examiner
EAST		
search terms: keyboard, multi-function, keys, default, press, duration, time, timer, phone, menu	2/3/14	AKW

INTERFERENCE SEARCH			
US Class/ CPC Symbol	US Subclass / CPC Group	Date	Examiner
all searched classes		3/20/14	AKW

--	--

PART B - FEE(S) TRANSMITTAL

Complete and send this form, together with applicable fee(s), to: **Mail** Mail Stop ISSUE FEE
Commissioner for Patents
P.O. Box 1450
Alexandria, Virginia 22313-1450
or Fax (571)-273-2885

INSTRUCTIONS: This form should be used for transmitting the ISSUE FEE and PUBLICATION FEE (if required). Blocks 1 through 5 should be completed where appropriate. All further correspondence including the Patent, advance orders and notification of maintenance fees will be mailed to the current correspondence address as indicated unless corrected below or directed otherwise in Block 1, by (a) specifying a new correspondence address; and/or (b) indicating a separate "FEE ADDRESS" for maintenance fee notifications.

CURRENT CORRESPONDENCE ADDRESS (Note: Use Block 1 for any change of address)

24737 7590 03/28/2014
PHILIPS INTELLECTUAL PROPERTY & STANDARDS
P.O. BOX 3001
BRIARCLIFF MANOR, NY 10510

Note: A certificate of mailing can only be used for domestic mailings of the Fee(s) Transmittal. This certificate cannot be used for any other accompanying papers. Each additional paper, such as an assignment or formal drawing, must have its own certificate of mailing or transmission.

Certificate of Mailing or Transmission

I hereby certify that this Fee(s) Transmittal is being deposited with the United States Postal Service with sufficient postage for first class mail in an envelope addressed to the Mail Stop ISSUE FEE address above, or being facsimile transmitted to the USPTO (571) 273-2885, on the date indicated below.

(Depositor's name)
(Signature)
(Date)

APPLICATION NO.	FILING DATE	FIRST NAMED INVENTOR	ATTORNEY DOCKET NO.	CONFIRMATION NO.
13/955,345	07/31/2013	Matthew J. Bickerton	2001P00413US01	6652

TITLE OF INVENTION: TEXT ENTRY METHOD AND DEVICE THEREFOR

APPLN. TYPE	ENTITY STATUS	ISSUE FEE DUE	PUBLICATION FEE DUE	PREV. PAID ISSUE FEE	TOTAL FEE(S) DUE	DATE DUE
nonprovisional	UNDISCOUNTED	\$960	\$0	\$0	\$960	06/30/2014

EXAMINER	ART UNIT	CLASS-SUBCLASS
WONG, ALBERT KANG	2689	341-022000

<p>1. Change of correspondence address or indication of "Fee Address" (37 CFR 1.363).</p> <p><input type="checkbox"/> Change of correspondence address (or Change of Correspondence Address form PTO/SB/122) attached.</p> <p><input type="checkbox"/> "Fee Address" indication (or "Fee Address" Indication form PTO/SB/47; Rev 03-02 or more recent) attached. Use of a Customer Number is required.</p>	<p>2. For printing on the patent front page, list</p> <p>(1) The names of up to 3 registered patent attorneys or agents OR, alternatively, _____ 1</p> <p>(2) The name of a single firm (having as a member a registered attorney or agent) and the names of up to 2 registered patent attorneys or agents. If no name is listed, no name will be printed. _____ 2</p> <p>_____ 3</p>
--	---

3. ASSIGNEE NAME AND RESIDENCE DATA TO BE PRINTED ON THE PATENT (print or type)

PLEASE NOTE: Unless an assignee is identified below, no assignee data will appear on the patent. If an assignee is identified below, the document has been filed for recordation as set forth in 37 CFR 3.11. Completion of this form is NOT a substitute for filing an assignment.

(A) NAME OF ASSIGNEE: Koninklijke Philips N.V.

(B) RESIDENCE: (CITY and STATE OR COUNTRY) Eindhoven, NL

Please check the appropriate assignee category or categories (will not be printed on the patent): Individual Corporation or other private group entity Government

<p>4a. The following fee(s) are submitted:</p> <p><input checked="" type="checkbox"/> Issue Fee</p> <p><input checked="" type="checkbox"/> Publication Fee (No small entity discount permitted)</p> <p><input type="checkbox"/> Advance Order - # of Copies _____</p>	<p>4b. Payment of Fee(s): (Please first reapply any previously paid issue fee shown above)</p> <p><input type="checkbox"/> A check is enclosed.</p> <p><input type="checkbox"/> Payment by credit card. Form PTO-2038 is attached.</p> <p><input checked="" type="checkbox"/> The Director is hereby authorized to charge the required fee(s), any deficiency, or credits any overpayment, to Deposit Account Number <u>14-1270</u> (enclose an extra copy of this form).</p>
---	---

5. Change in Entity Status (from status indicated above)

Applicant certifying micro entity status. See 37 CFR 1.29

Applicant asserting small entity status. See 37 CFR 1.27

Applicant changing to regular undiscounted fee status.

NOTE: Absent a valid certification of Micro Entity Status (see forms PTO/SB/15A and 15B), issue fee payment in the micro entity amount will not be accepted at the risk of application abandonment.

NOTE: If the application was previously under micro entity status, checking this box will be taken to be a notification of loss of entitlement to micro entity status.

NOTE: Checking this box will be taken to be a notification of loss of entitlement to small or micro entity status, as applicable.

NOTE: This form must be signed in accordance with 37 CFR 1.31 and 1.33. See 37 CFR 1.4 for signature requirements and certifications.

Authorized Signature /Michael E. Belk/ Date April 2, 2014

Typed or printed name Michael E. Belk Registration No. 33,357

Electronic Patent Application Fee Transmittal

Application Number:	13955345			
Filing Date:	31-Jul-2013			
Title of Invention:	TEXT ENTRY METHOD AND DEVICE THEREFOR			
First Named Inventor/Applicant Name:	Matthew J. Bickerton			
Filer:	Michael E. Belk/Elissa DeLuccy			
Attorney Docket Number:	2001P00413US01			
Filed as Large Entity				
Utility under 35 USC 111(a) Filing Fees				
Description	Fee Code	Quantity	Amount	Sub-Total in USD(\$)
Basic Filing:				
Pages:				
Claims:				
Miscellaneous-Filing:				
Petition:				
Patent-Appeals-and-Interference:				
Post-Allowance-and-Post-Issuance:				
Utility Appl Issue Fee	1501	1	960	960
Extension-of-Time:				

Description	Fee Code	Quantity	Amount	Sub-Total in USD(\$)
Miscellaneous:				
Total in USD (\$)				960

Electronic Acknowledgement Receipt

EFS ID:	18647069
Application Number:	13955345
International Application Number:	
Confirmation Number:	6652
Title of Invention:	TEXT ENTRY METHOD AND DEVICE THEREFOR
First Named Inventor/Applicant Name:	Matthew J. Bickerton
Customer Number:	24737
Filer:	Michael E. Belk/Elissa DeLuccy
Filer Authorized By:	Michael E. Belk
Attorney Docket Number:	2001P00413US01
Receipt Date:	02-APR-2014
Filing Date:	31-JUL-2013
Time Stamp:	10:00:41
Application Type:	Utility under 35 USC 111(a)

Payment information:

Submitted with Payment	yes
Payment Type	Deposit Account
Payment was successfully received in RAM	\$960
RAM confirmation Number	7193
Deposit Account	141270
Authorized User	

The Director of the USPTO is hereby authorized to charge indicated fees and credit any overpayment as follows:

Charge any Additional Fees required under 37 C.F.R. Section 1.17 (Patent application and reexamination processing fees)

File Listing:

Document Number	Document Description	File Name	File Size(Bytes)/ Message Digest	Multi Part /.zip	Pages (if appl.)
1	Issue Fee Payment (PTO-85B)	2001P00413US01_Issue_Fee.pdf	86380 244c1abab04a1a6d5f9b17d4c6d10e121264b03	no	1

Warnings:

Information:

2	Fee Worksheet (SB06)	fee-info.pdf	30442 39b8f9516ef766c05b0ee2ddbf7d288f6e54ea0	no	2
---	----------------------	--------------	--	----	---

Warnings:

Information:

Total Files Size (in bytes):	116822
-------------------------------------	--------

This Acknowledgement Receipt evidences receipt on the noted date by the USPTO of the indicated documents, characterized by the applicant, and including page counts, where applicable. It serves as evidence of receipt similar to a Post Card, as described in MPEP 503.

New Applications Under 35 U.S.C. 111

If a new application is being filed and the application includes the necessary components for a filing date (see 37 CFR 1.53(b)-(d) and MPEP 506), a Filing Receipt (37 CFR 1.54) will be issued in due course and the date shown on this Acknowledgement Receipt will establish the filing date of the application.

National Stage of an International Application under 35 U.S.C. 371

If a timely submission to enter the national stage of an international application is compliant with the conditions of 35 U.S.C. 371 and other applicable requirements a Form PCT/DO/EO/903 indicating acceptance of the application as a national stage submission under 35 U.S.C. 371 will be issued in addition to the Filing Receipt, in due course.

New International Application Filed with the USPTO as a Receiving Office

If a new international application is being filed and the international application includes the necessary components for an international filing date (see PCT Article 11 and MPEP 1810), a Notification of the International Application Number and of the International Filing Date (Form PCT/RO/105) will be issued in due course, subject to prescriptions concerning national security, and the date shown on this Acknowledgement Receipt will establish the international filing date of the application.



UNITED STATES PATENT AND TRADEMARK OFFICE

UNITED STATES DEPARTMENT OF COMMERCE
United States Patent and Trademark Office
Address: COMMISSIONER FOR PATENTS
P.O. Box 1450
Alexandria, Virginia 22313-1450
www.uspto.gov

Table with 5 columns: APPLICATION NO., ISSUE DATE, PATENT NO., ATTORNEY DOCKET NO., CONFIRMATION NO.
Row 1: 13/955,345, 05/27/2014, RE44913, 2001P00413US01, 6652

24737 7590 05/07/2014
PHILIPS INTELLECTUAL PROPERTY & STANDARDS
P.O. BOX 3001
BRIARCLIFF MANOR, NY 10510

ISSUE NOTIFICATION

The projected patent number and issue date are specified above.

Determination of Patent Term Extension or Adjustment under 35 U.S.C. 154 (b)

A reissue patent is for "the unexpired part of the term of the original patent." See 35 U.S.C. 251. Accordingly, the above-identified reissue application is not eligible for Patent Term Extension or Adjustment under 35 U.S.C. 154(b).

Any questions regarding the Patent Term Extension or Adjustment determination should be directed to the Office of Patent Legal Administration at (571)-272-7702. Questions relating to issue and publication fee payments should be directed to the Application Assistance Unit (AAU) of the Office of Data Management (ODM) at (571)-272-4200.

APPLICANT(s) (Please see PAIR WEB site http://pair.uspto.gov for additional applicants):

Matthew J. Bickerton, Bletchingley, UNITED KINGDOM;

The United States represents the largest, most dynamic marketplace in the world and is an unparalleled location for business investment, innovation, and commercialization of new technologies. The USA offers tremendous resources and advantages for those who invest and manufacture goods here. Through SelectUSA, our nation works to encourage and facilitate business investment. To learn more about why the USA is the best country in the world to develop technology, manufacture products, and grow your business, visit SelectUSA.gov.

AO 120 (Rev. 08/10)

TO: Mail Stop 8 Director of the U.S. Patent and Trademark Office P.O. Box 1450 Alexandria, VA 22313-1450	REPORT ON THE FILING OR DETERMINATION OF AN ACTION REGARDING A PATENT OR TRADEMARK
---	---

In Compliance with 35 U.S.C. § 290 and/or 15 U.S.C. § 1116 you are hereby advised that a court action has been filed in the U.S. District Court _____ for the District of Delaware _____ on the following

Trademarks or Patents. (the patent action involves 35 U.S.C. § 292.):

DOCKET NO. 14-602-GMS	DATE FILED 6/18/2014	U.S. DISTRICT COURT for the District of Delaware
PLAINTIFF KONINKLIJKE PHILIPS N.V. and U.S. PHILIPS CORPORATION		DEFENDANT NINTENDO CO., LTD. and NINTENDO OF AMERICA INC.
PATENT OR TRADEMARK NO.	DATE OF PATENT OR TRADEMARK	HOLDER OF PATENT OR TRADEMARK
1 6,285,379	9/4/2001	U.S. Philips Corporation
2 8,537,231	9/17/2013	Koninklijke Philips N.V.
3		
4		
5		

In the above—entitled case, the following patent(s)/ trademark(s) have been included:

DATE INCLUDED	INCLUDED BY <input checked="" type="checkbox"/> Amendment <input type="checkbox"/> Answer <input type="checkbox"/> Cross Bill <input type="checkbox"/> Other Pleading	
PATENT OR TRADEMARK NO.	DATE OF PATENT OR TRADEMARK	HOLDER OF PATENT OR TRADEMARK
1 6,690,387	2/10/2004	Koninklijke Philips N.V.
2 7,184,064	2/27/2007	Koninklijke Philips N.V.
3 RE 44,913	5/27/2014	Koninklijke Philips N.V.
4 7,529,806	5/5/2009	Koninklijke Philips N.V.
5		

In the above—entitled case, the following decision has been rendered or judgement issued:

DECISION/JUDGEMENT

CLERK	(BY) DEPUTY CLERK	DATE
-------	-------------------	------

Copy 1—Upon initiation of action, mail this copy to Director Copy 3—Upon termination of action, mail this copy to Director
 Copy 2—Upon filing document adding patent(s), mail this copy to Director Copy 4—Case file copy

AO 120 (Rev. 08/10)

TO: Mail Stop 8 Director of the U.S. Patent and Trademark Office P.O. Box 1450 Alexandria, VA 22313-1450	REPORT ON THE FILING OR DETERMINATION OF AN ACTION REGARDING A PATENT OR TRADEMARK
--	---

In Compliance with 35 U.S.C. § 290 and/or 15 U.S.C. § 1116 you are hereby advised that a court action has been filed in the U.S. District Court _____ for the District of Delaware _____ on the following

Trademarks or Patents. (the patent action involves 35 U.S.C. § 292.);

DOCKET NO.	DATE FILED 12/7/2015	U.S. DISTRICT COURT for the District of Delaware
PLAINTIFF KONINKLIJKE PHILIPS N.V., U.S. PHILIPS CORPORATION		DEFENDANT DIGITAL PRODUCTS INTERNATIONAL, INC.
PATENT OR TRADEMARK NO.	DATE OF PATENT OR TRADEMARK	HOLDER OF PATENT OR TRADEMARK
1 RE44,913	5/27/2014	Koninklijke Philips N.V. and U.S. Philips Corporation
2 6,690,387	2/10/2004	Koninklijke Philips N.V. and U.S. Philips Corporation
3 7,184,064	2/27/2007	Koninklijke Philips N.V. and U.S. Philips Corporation
4 7,529,806	5/5/2009	Koninklijke Philips N.V. and U.S. Philips Corporation
5 5,910,797	6/8/1999	Koninklijke Philips N.V. and U.S. Philips Corporation

In the above—entitled case, the following patent(s)/ trademark(s) have been included:

DATE INCLUDED	INCLUDED BY <input type="checkbox"/> Amendment <input type="checkbox"/> Answer <input type="checkbox"/> Cross Bill <input type="checkbox"/> Other Pleading		
PATENT OR TRADEMARK NO.	DATE OF PATENT OR TRADEMARK	HOLDER OF PATENT OR TRADEMARK	
1			
2			
3			
4			
5			

In the above—entitled case, the following decision has been rendered or judgement issued:

DECISION/JUDGEMENT <i>Dismissed - See Attached</i>

John A Cerino, Clerk

CLERK United States District Court 844 N. King Street, Unit 18 Wilmington, DE 19801	(BY) DEPUTY CLERK 	DATE 3/4/16
---	-----------------------	----------------

Copy 1—Upon initiation of action, mail this copy to Director Copy 3—Upon termination of action, mail this copy to Director
 Copy 2—Upon filing document adding patent(s), mail this copy to Director Copy 4—Case file copy