



US006760935B1

(12) **United States Patent**
Burton et al.

(10) **Patent No.:** **US 6,760,935 B1**
(45) **Date of Patent:** **Jul. 13, 2004**

(54) **GUSSETED PILLOW WITH PLEATED TOP AND BOTTOM SECTIONS**

3,175,230 A * 3/1965 Herdal 5/491
3,443,267 A * 5/1969 Meyers 5/645
4,513,462 A * 4/1985 Thomas 5/645

(75) Inventors: **Robert D. Burton**, Shoreline, WA (US); **Ralph W. Saterlee**, Seattle, WA (US); **Shelley A. DiGirolamo**, Bellevue, WA (US)

* cited by examiner

(73) Assignee: **Pacific Coast Feather Co.**, Seattle, WA (US)

Primary Examiner—Michael Trettel
(74) *Attorney, Agent, or Firm*—Jensen & Puntigam, P.S.

(*) Notice: Subject to any disclaimer, the term of this patent is extended or adjusted under 35 U.S.C. 154(b) by 0 days.

(57) **ABSTRACT**

The gusseted pillow includes a top fabric section, a bottom fabric section and an intermediate gusset portion, wherein the peripheries of the top and bottom fabric sections are each longer than a total length of the gusset portion. The peripheral edges of the top and bottom fabric sections are attached, respectively, to the opposing edges of the gusset portion, with pleats at the corners of the pillow. The pillow is filled to produce a high loft (puffy) appearance, with the portion of the pillow on opposing sides of the gusset portion being elevated from the gusset portion.

(21) Appl. No.: **10/402,605**

(22) Filed: **Mar. 28, 2003**

(51) **Int. Cl.**⁷ **A47G 9/10**

(52) **U.S. Cl.** **5/645; 5/636**

(58) **Field of Search** **5/636-645, 490, 5/491**

(56) **References Cited**

U.S. PATENT DOCUMENTS

2,805,428 A * 9/1957 Buchman 5/645

8 Claims, 3 Drawing Sheets

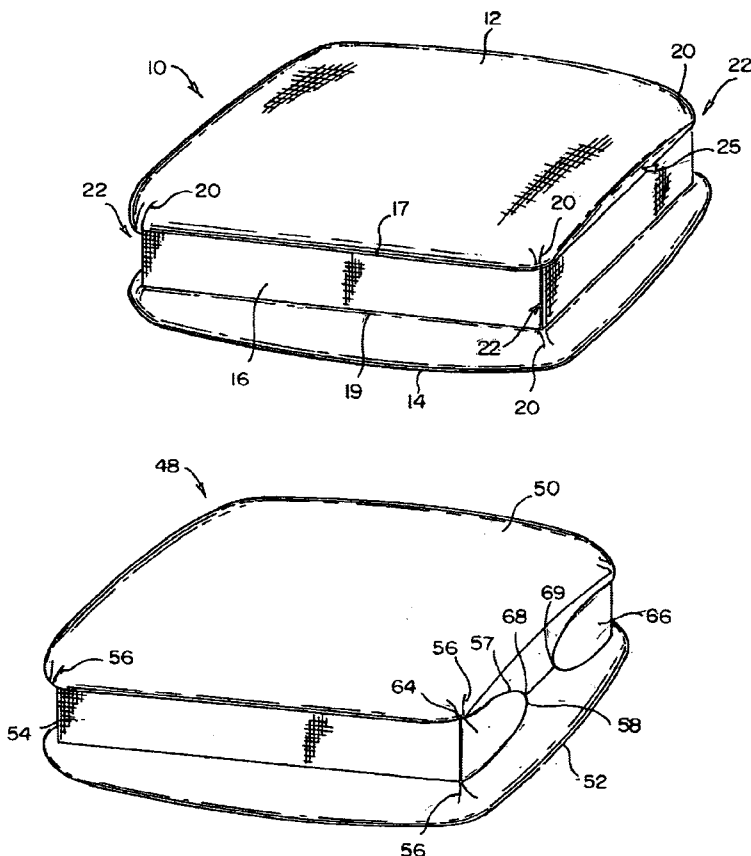

FIG. 1

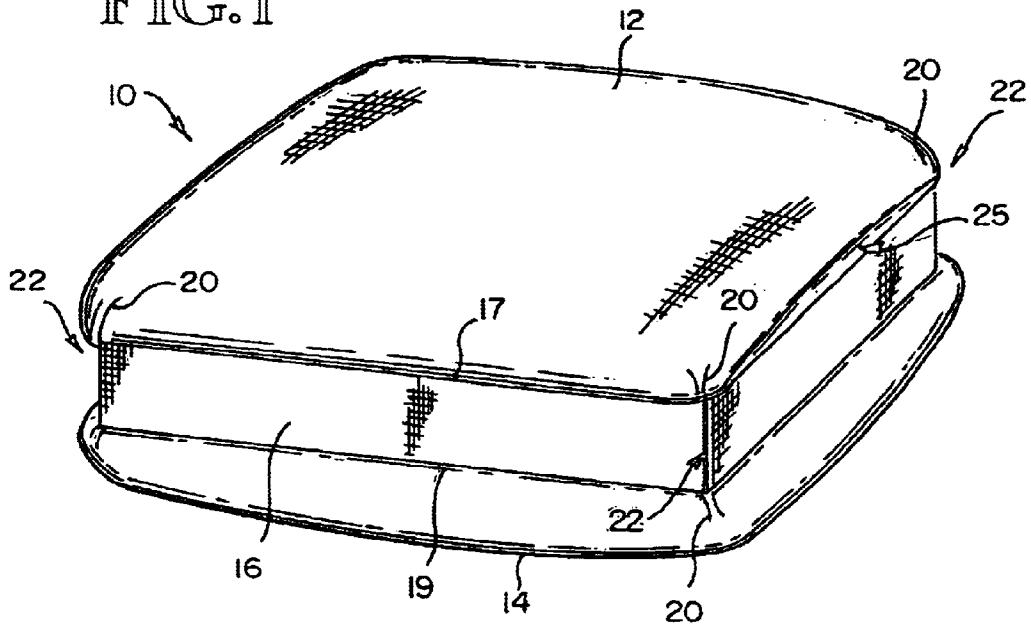
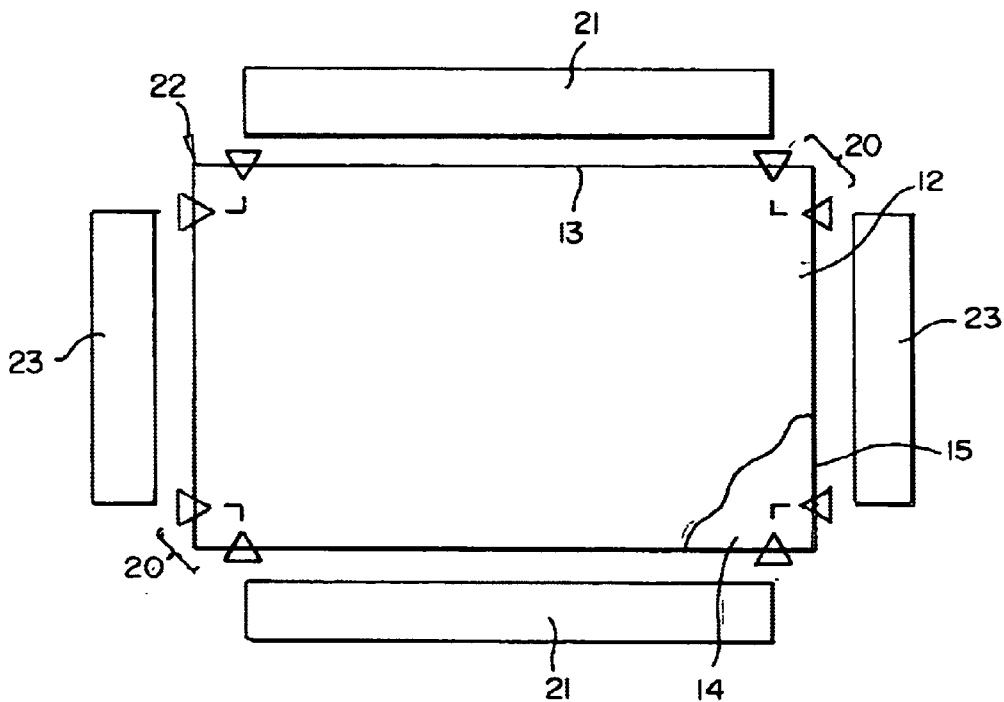
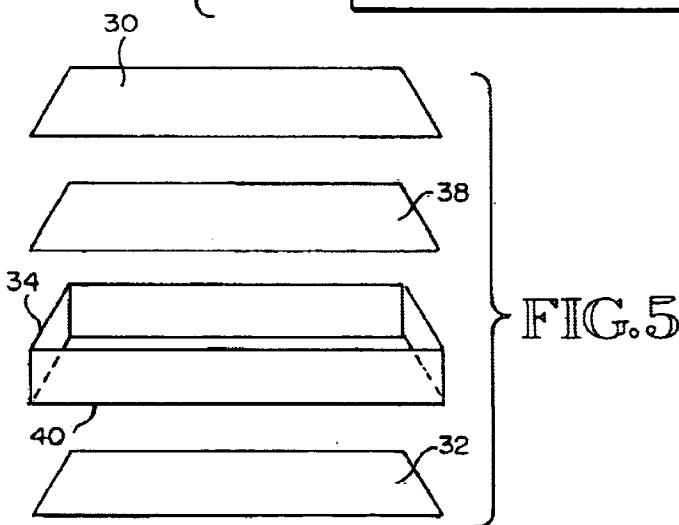
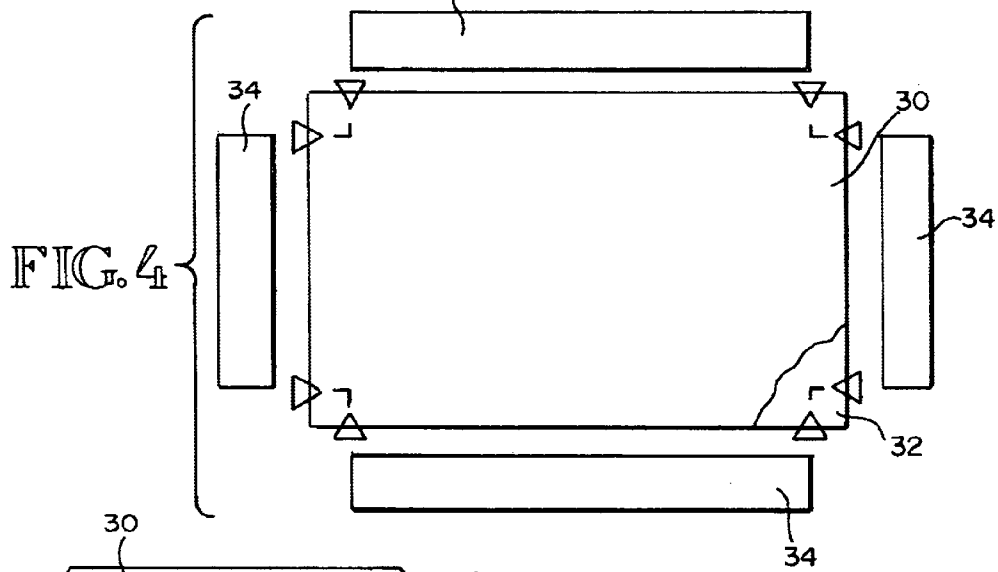
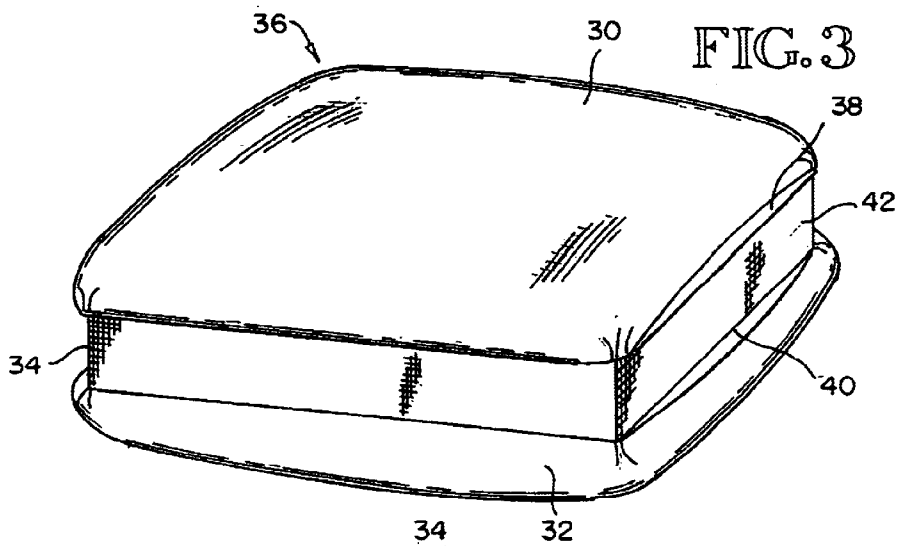
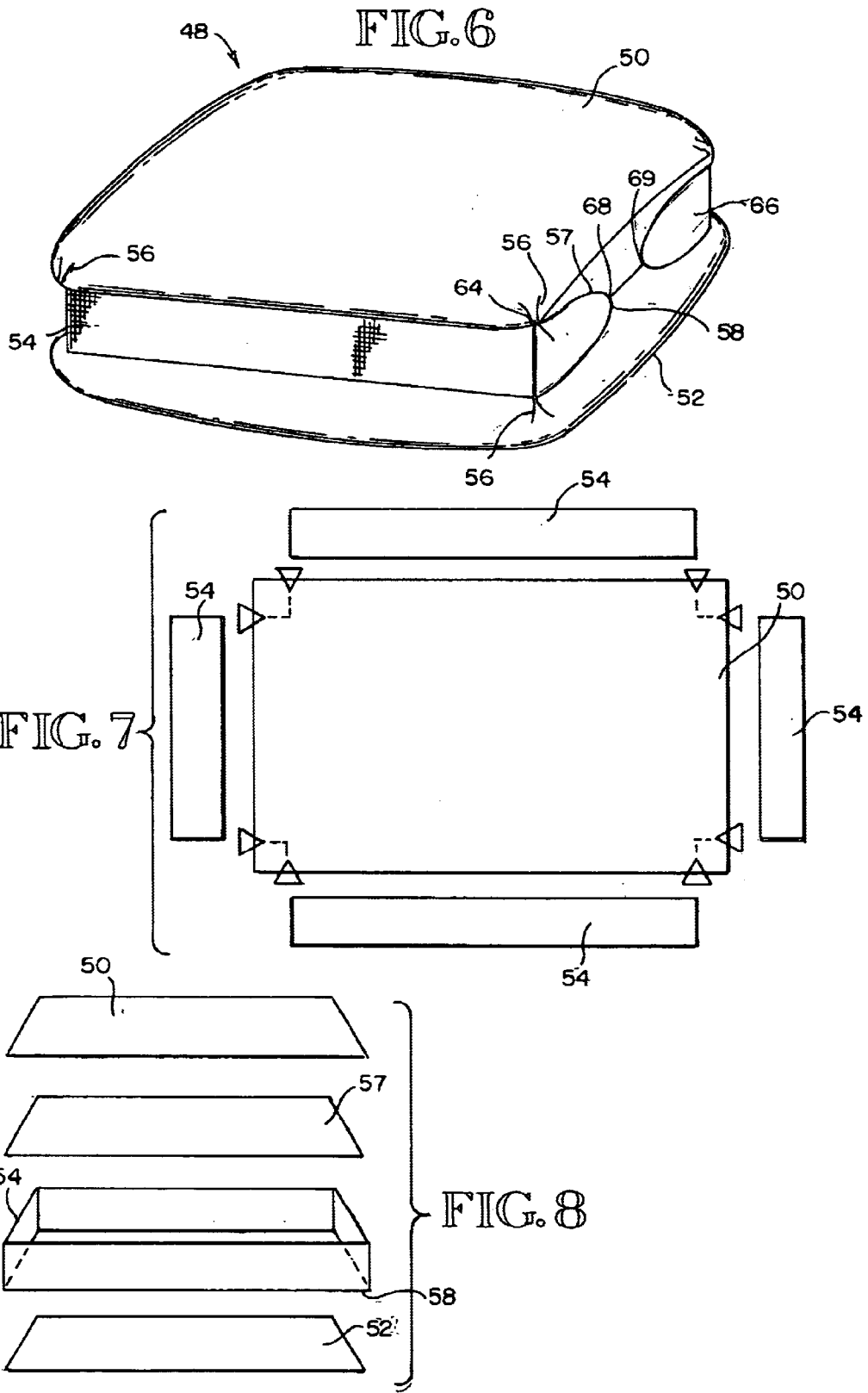

FIG. 2







1

GUSSETED PILLOW WITH PLEATED TOP AND BOTTOM SECTIONS

TECHNICAL FIELD

This invention relates generally to pillow construction, and more specifically concerns a gusseted pillow being a particular top and bottom section arrangement and an intermediate gusset portion.

BACKGROUND OF THE INVENTION

Gusseted pillows are in general well known, as shown for instance in U.S. Pat. No. 5,729,851 to Hollander and U.S. Pat. No. 3,109,182 to Doak, each of which generally teach a pillow having a narrow gusset between top and bottom sections. However, the total length of the gusset in those patents is approximately the same as the total length of the peripheral edge of the top and bottom sections, so that when the pillow is sewn together and filled, the top and bottom sections of the pillow tend to curve inwardly toward the center of the pillow in defining the upper and lower surfaces of the pillow.

In general, comfort and appearance are both important aspects of a pillow. Conventional gusseted pillows are generally quite ordinary in comfort, depending to some extent on the fill, and also in appearance. The present invention results in a high loft gusseted pillow, which adds to the overall comfort and appearance of otherwise conventional gusseted pillows.

SUMMARY OF THE INVENTION

Accordingly, the present invention is a gusseted pillow with a pleated portion, comprising: a top fabric section; a bottom fabric section; a center gusset portion having a selected length, wherein the top fabric section is attached along its peripheral edge to an upper edge of the gusset portion, and the bottom fabric section is attached along its peripheral edge to an opposing lower edge of the gusset portion, wherein the periphery of at least one of the top and bottom fabric sections is larger from the length of the gusset portion, and wherein said at least one fabric section has a plurality of pleats at spaced intervals around the periphery thereof where it is attached to said gusset portion; and sufficient filling within the pillow that the pillow puffs up from the gusset portion.

BRIEF DESCRIPTION OF THE DRAWINGS

FIG. 1 is a perspective view of one embodiment of the pillow of the present invention.

FIG. 2 is a diagram showing the configuration of the top and bottom sections of the pillow of FIG. 1 and the configuration of the gusset portion.

FIGS. 3-5 show a second pillow arrangement using the principles of the present invention.

FIGS. 6-8 show another pillow arrangement using the principles of the present invention.

BEST MODE FOR CARRYING OUT THE INVENTION

In general, the present invention is a high loft pillow which has a "puffy" appearance, comprising top and bottom fabric sections with a particular configuration and an inter-

2

bottom fabric sections **12** and **14** and an intermediate gusset portion **16**. The peripheral edges **13**, **15** of the top and bottom fabric sections **12**, **14** are longer than the corresponding upper (top) and lower (bottom) edges **17**, **19** of gusset portion **16**. In the embodiment shown, although not necessarily, the top and bottom fabric sections are made of cotton or similar fabric, with a 260 thread count, although this can certainly be varied.

In the embodiment shown, the top and bottom fabric sections are rectangular in configuration, with a length of approximately 23.5 inches (with a 0.5 inch seam allowance) and a width of approximately 16 inches (with a 0.5 inch seam allowance). The gusset portion **16** is also made from cotton or similar material, also with a thread count of 260, although again this can be varied. FIG. 2 also shows the length and width of the gusset portion. Typically, the gusset portion **16** is a continuous strip; it is shown in individual parts in FIG. 2 to match the four sides of the top and bottom sections. In the embodiment shown, the pillow length parts **21** of the gusset are approximately 22 inches (with a 0.5 inch seam allowance) and the pillow width parts **23** of the gusset are 16 inches (with a 0.5 inch seam allowance), for a total gusset length of 76 inches. In the embodiment shown, the width of gusset **16** is approximately two inches.

In FIG. 1, the peripheral edges of the top and bottom fabric sections are sewn, respectively, to the upper (top) and lower (bottom) edges **17** and **19** of gusset portion **16**, although one end **25** of the pillow is left open initially to permit filling of the pillow. The top and bottom sections include pleats **20-20** at each corner **22-22** of the top and bottom fabric sections, or at other spaced points along the periphery thereof. Alternatively, a dart could be used or any similar "bunched" arrangement. Hereinafter, the word "pleat" is intended to cover all such arrangements. In the embodiment shown, with the dimensions of the fabric sections and the gusset as set forth above, each pleat is $\frac{3}{4}$ inches, as shown in FIG. 2. The size of the pleat can vary within the concept of the present invention, depending upon the difference in length between the peripheral edge of the top and bottom fabric sections **12**, **14** and the length of gusset portion **16**. When the sewn pillow **10** is filled, the top and bottom fabric sections will typically extend upwardly and slightly outwardly from the gusset portion of the pillow, giving a lofted, i.e. puffy, appearance to the pillow, as shown in FIG. 1. The above-described arrangement adds both to the appearance and the comfort of a conventional gusseted pillow.

The sewn pillow can be stuffed in conventional ways, either with feathers or down or a combination thereof or by synthetic products, such as foam or fiber material, either a single block or smaller portions thereof. After filling, the open end **25** of the pillow is sewn shut to complete the construction of the pillow.

As an alternative to the embodiment of FIGS. 1 and 2, one of the top and bottom fabric sections in FIG. 1 could have smaller dimensions than the other, for instance the bottom section could be smaller, resulting in the bottom portion of the pillow being less lofted or puffy. Further, one fabric section could have approximately the same peripheral edge length as the length of the gusset portion, which results in that portion (half) of the pillow having a conventional pillow appearance, while the other half has a high loft or puffy appearance. In such a case, the lower part of the pillow could be filled with foam or fiber material, while the upper portion could be filled with feathers or down.

Explore Litigation Insights

Docket Alarm provides insights to develop a more informed litigation strategy and the peace of mind of knowing you're on top of things.

Real-Time Litigation Alerts



Keep your litigation team up-to-date with **real-time alerts** and advanced team management tools built for the enterprise, all while greatly reducing PACER spend.

Our comprehensive service means we can handle Federal, State, and Administrative courts across the country.

Advanced Docket Research



With over 230 million records, Docket Alarm's cloud-native docket research platform finds what other services can't. Coverage includes Federal, State, plus PTAB, TTAB, ITC and NLRB decisions, all in one place.

Identify arguments that have been successful in the past with full text, pinpoint searching. Link to case law cited within any court document via Fastcase.

Analytics At Your Fingertips



Learn what happened the last time a particular judge, opposing counsel or company faced cases similar to yours.

Advanced out-of-the-box PTAB and TTAB analytics are always at your fingertips.

API

Docket Alarm offers a powerful API (application programming interface) to developers that want to integrate case filings into their apps.

LAW FIRMS

Build custom dashboards for your attorneys and clients with live data direct from the court.

Automate many repetitive legal tasks like conflict checks, document management, and marketing.

FINANCIAL INSTITUTIONS

Litigation and bankruptcy checks for companies and debtors.

E-DISCOVERY AND LEGAL VENDORS

Sync your system to PACER to automate legal marketing.