

MEDICAL SCIENCE SERIES

# DESIGN OF PULSE OXIMETERS

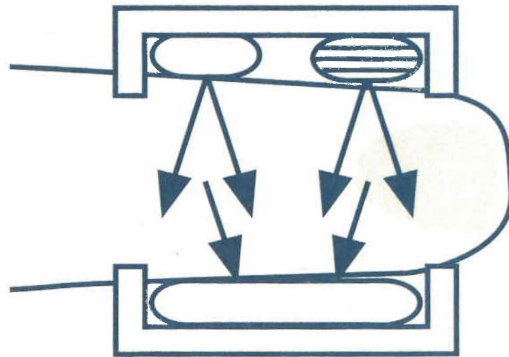

EDITED BY  
**J G WEBSTER**  
**IoP**

# **Design of Pulse Oximeters**

*Other books in the series*

**The Physics and Radiobiology of Fast Neutron Beams**

D K Bewley

**Biomedical Magnetic Resonance Technology**

C-N Chen and D I Hoult

**Rehabilitation Engineering Applied to Mobility and Manipulation**

R A Cooper

**Linear Accelerators for Radiation Therapy, second edition**

D Greene and P C Williams

**Health Effects of Exposure to Low-Level Ionizing Radiation**

W R Hendee and F M Edwards

**Introductory Medical Statistics, third edition**

R F Mould

**Radiation Protection in Hospitals**

R F Mould

**RPL Dosimetry—Radiophotoluminescence in Health Physics**

J A Perry

**Physics of Heart and Circulation**

J Strackee and N Westerhof

**The Physics of Medical Imaging**

S Webb

**The Physics of Three-Dimensional Radiation Therapy: Conformal Radiotherapy, Radiosurgery and Treatment Planning**

S Webb

**The Physics of Conformal Radiotherapy: Advances in Technology**

S Webb

*Other titles of interest*

**Prevention of Pressure Sores: Engineering and Clinical Aspects**

J G Webster

Medical Science Series

# **Design of Pulse Oximeters**

Edited by

**J G Webster**

Department of Electrical and Computer Engineering  
University of Wisconsin-Madison

Institute of Physics Publishing  
Bristol and Philadelphia

© IOP Publishing Ltd 1997

All rights reserved. No part of this publication may be reproduced, stored in a retrieval system or transmitted in any form or by any means, electronic, mechanical, photocopying, recording or otherwise, without the prior permission of the publisher. Multiple copying is permitted in accordance with the terms of licences issued by the Copyright Licensing Agency under the terms of its agreement with the Committee of Vice-Chancellors and Principals.

*British Library Cataloguing-in-Publication Data*

A catalogue record for this book is available from the British Library.

ISBN 0 7503 0467 7

*Library of Congress Cataloguing-in-Publication Data are available*

The Editor has attempted to trace the copyright holder of all the figures and tables reproduced in this publication and apologizes to copyright holders if permission to publish in this form has not been obtained.

Series Editors:

**R F Mould**, Croydon, UK

**C G Orton**, Karamanos Cancer Institute, Detroit, USA

**J A E Spaan**, University of Amsterdam, The Netherlands

**J G Webster**, University of Wisconsin-Madison, USA

Published by Institute of Physics Publishing, wholly owned by The Institute of Physics, London

Institute of Physics Publishing, Dirac House, Temple Back, Bristol BS1 6BE, UK

US Editorial Office: Institute of Physics Publishing, The Public Ledger Building, Suite 1035, 150 South Independence Mall West, Philadelphia, PA 19106, USA

Prepared by the Editor using Microsoft Word 6

Printed in Great Britain by J W Arrowsmith Ltd, Bristol

**The Medical Science Series is the official book series of the International Federation for Medical and Biological Engineering (IFMBE) and the International Organization for Medical Physics (IOMP).**

## **IFMBE**

The IFMBE was established in 1959 to provide medical and biological engineering with an international presence. The Federation has a long history of encouraging and promoting international cooperation and collaboration in the use of technology for improving the health and life quality of man.

The IFMBE is an organization that is mostly an affiliation of national societies. Transnational organizations can also obtain membership. At present there are 42 national members, and one transnational member with a total membership in excess of 15 000. An observer category is provided to give personal status to groups or organizations considering formal affiliation.

## **Objectives**

- To reflect the interests and initiatives of the affiliated organizations.
- To generate and disseminate information of interest to the medical and biological engineering community and international organizations.
- To provide an international forum for the exchange of ideas and concepts.
- To encourage and foster research and application of medical and biological engineering knowledge and techniques in support of life quality and cost-effective health care.
- To stimulate international cooperation and collaboration on medical and biological engineering matters.
- To encourage educational programmes which develop scientific and technical expertise in medical and biological engineering.

## **Activities**

The IFMBE has published the journal *Medical and Biological Engineering and Computing* for over 34 years. A new journal *Cellular Engineering* was established in 1996 in order to stimulate this emerging field in biomedical engineering. In *IFMBE News* members are kept informed of the developments in the Federation. *Clinical Engineering Update* is a publication of our division of Clinical Engineering. The Federation also has a division for Technology Assessment in Health Care.

Every three years, the IFMBE holds a World Congress on Medical Physics and Biomedical Engineering, organized in cooperation with the IOMP and the IUPESM. In addition, annual, milestone, regional conferences are organized in different regions of the world, such as the Asia Pacific, Baltic, Mediterranean, African and South American regions.

The administrative council of the IFMBE meets once or twice a year and is the steering body for the IFMBE. The council is subject to the rulings of the General Assembly which meets every three years.

For further information on the activities of the IFMBE, please contact Jos A E Spaan, Professor of Medical Physics, Academic Medical Centre, University of Amsterdam, PO Box 22660, Meibergdreef 9, 1105 AZ, Amsterdam, The Netherlands. Tel: 31 (0) 20 566 5200. Fax: 31 (0) 20 6917233. Email: IFMBE@amc.uva.nl. WWW: <http://vub.vub.ac.be/~ifmbe>.

## **IOMP**

The IOMP was founded in 1963. The membership includes 64 national societies, two international organizations and 12 000 individuals. Membership of IOMP consists of individual members of the Adhering National Organizations. Two other forms of membership are available, namely Affiliated Regional Organization and Corporate Members. The IOMP is administered by a Council, which consists of delegates from each of the Adhering National Organizations; regular meetings of Council are held every three years at the International Conference on Medical Physics (ICMP). The Officers of the Council are the President, the Vice-President and the Secretary-General. IOMP committees include: developing countries, education and training; nominating; and publications.

## **Objectives**

- To organize international cooperation in medical physics in all its aspects, especially in developing countries.
- To encourage and advise on the formation of national organizations of medical physics in those countries which lack such organizations.

## **Activities**

Official publications of the IOMP are *Physiological Measurement*, *Physics in Medicine and Biology* and the *Medical Science Series*, all published by Institute of Physics Publishing. The IOMP publishes a bulletin *Medical Physics World* twice a year.

Two Council meetings and one General Assembly are held every three years at the ICMP. The most recent ICMPs were held in Kyoto, Japan (1991) and Rio de Janeiro, Brazil (1994). Future conferences are scheduled for Nice, France (1997) and Chicago, USA (2000). These conferences are normally held in collaboration with the IFMBE to form the World Congress on Medical Physics and Biomedical Engineering. The IOMP also sponsors occasional international conferences, workshops and courses.

For further information contact: Hans Svensson, PhD, DSc, Professor, Radiation Physics Department, University Hospital, 90185 Umeå, Sweden, Tel: (46) 90 785 3891, Fax: (46) 90 785 1588, email: [Hans.Svensson@radfys.umu.se](mailto:Hans.Svensson@radfys.umu.se).

# CONTENTS

---

PREFACE	xv
1 NORMAL OXYGEN TRANSPORT	1
<i>Susanne A Clark</i>	
1.1 Ventilatory control	1
1.1.1 Neural control	1
1.1.2 Respiratory feedback	2
1.2 Ventilatory mechanics	2
1.2.2 Expiration	4
1.3 Diffusion to blood	5
1.3.1 The alveoli	5
1.3.2 Gas exchange	5
1.4 Bind to hemoglobin	6
1.4.1 Characteristics of hemoglobin	6
1.4.2 Oxyhemoglobin dissociation curves	7
1.5 Dissolved in plasma	8
1.6 Circulation	8
1.6.1 The heart	8
1.6.2 Pulmonary circulation	9
1.6.3 Systemic circulation	9
1.6.4 Cardiac output	9
1.7 Diffusion to tissue	10
1.7.1 Diffusion into interstitial fluid and cell	11
1.7.2 Oxygen delivered	11
1.7.3 Myoglobin	11
1.8 Use in cell	11
References	12
Instructional objectives	12
2 MOTIVATION OF PULSE OXIMETRY	13
<i>Daniel J Sebald</i>	
2.1 Pulse oximeter principles	13
2.2.1 Comprehensive approach	15
2.2.2 Arterial oxygen saturation	15
2.2.3 Hypoxia and hypoxemia	15
2.2.4 Role of $S_pO_2$ in avoiding hypoxia	16



2.2.5	Photoplethysmography	18
2.2.6	Hyperoxia	10
2.3	Limitations	19
2.3.1	Instrument and operation limitations	19
2.3.1	Limitations in $S_pO_2$	19
	References	20
	Instructional objectives	20
3	<b>BLOOD OXYGEN MEASUREMENT</b>	21
	<i>James Farmer</i>	
3.1	Chemical methods	21
3.1.1	Van Slyke method	22
3.1.2	Mixing syringe method	23
3.1.3	The Clark electrode	23
3.1.4	The galvanic electrode	25
3.2	Transcutaneous $PO_2$ sensor	25
3.3	<i>In vitro</i> oximeters	26
3.3.1	Spectrophotometers	26
3.3.2	The CO-oximeter	28
3.4	<i>In vivo</i> two-wavelength oximeters	30
3.4.1	The first <i>in vivo</i> oximeters	30
3.4.2	The cyclops	30
3.5	Fiber optic oximeters	30
3.5.1	<i>In vitro</i> reflectance oximeter	30
3.5.2	<i>In vivo</i> reflectance catheter oximeter	31
3.5.3	<i>In vivo</i> chemical oximeter	32
3.6	<i>In vivo</i> eight-wavelength oximeter	32
3.7	Pulse oximeters	34
3.7.1	Overview	34
3.7.2	LEDs	35
3.7.3	Photodiode	36
3.7.4	Probes	36
3.7.5	Analog amplifier and signal processing	37
3.7.6	A three-wavelength pulse oximeter for COHb determination	37
3.7.7	Comparison of pulse oximetry to transcutaneous $PO_2$ electrodes	38
	References	38
	Instructional objectives	39
4	<b>LIGHT ABSORBANCE IN PULSE OXIMETRY</b>	40
	<i>Oliver Wieben</i>	
4.1	Beer's Law	40
4.1.1	Transmittance and absorbance of light	41
4.1.2	Multiple absorbers	41

4.2	Hemoglobin extinction coefficients	42
4.2.1	Functional hemoglobins	42
4.2.2	Dysfunctional hemoglobins	42
4.2.3	Hemoglobin absorbance spectra	44
4.3	Beer's law in pulse oximetry	44
4.3.1	Criteria for the choice of wavelengths	45
4.3.2	Absorbance in hemoglobin solutions	45
4.3.3	Pulsation of the blood	46
4.3.4	Measurement of pulse oximeters	48
4.4	Saturation versus normalized ratio	49
4.4.1	Normalization	49
4.4.2	Ratio of normalized signals	49
4.4.3	Theoretic calibration curve	50
4.5	Validity of Beer's law in pulse oximetry	51
4.6	Light Scattering	52
4.6.1	Light absorbance in whole blood	52
4.6.2	Models for light absorbance including scattering	52
4.6.3	Influence of scattering on pulse oximeter readings	53
4.6.4	Calibration curves used for pulse oximeters	54
	References	54
	Instructional objectives	55
5	LIGHT-EMITTING DIODES AND THEIR CONTROL	56
	<i>Brad W J Bourgeois</i>	
5.1	An introduction to light-emitting diodes	56
5.1.1	Description, materials, and operation	57
5.1.2	Bandwidth considerations	57
5.2	Light-emitting diode specifications	57
5.2.1	Forward voltage	58
5.2.2	Forward current	58
5.2.3	Power dissipation	59
5.2.4	Reverse breakdown voltage	60
5.2.5	Reverse current	60
5.2.6	Operating temperature	60
5.2.7	Switching times	61
5.2.8	Beam angle	61
5.2.9	Pulse capability	61
5.3	Measuring and identifying LED wavelengths	62
5.4	LED driver circuit	64
5.5	LED peak wavelength shift with temperature	66
5.5.1	p-n junction heating	66
5.5.2	Studies	66
5.5.3	Two methods to compensate for LED temperature changes	68
5.6	Prevention of burns in pulse oximetry	69
5.7	LED packaging	69
	References	70
	Instructional objectives	70

6	PHOTODETECTORS AND AMPLIFIERS	71
	<i>Jeffrey S Schowalter</i>	
6.1	Photodetection devices	71
6.1.1	Photocells	71
6.1.2	Photodiodes	72
6.1.3	Phototransistors	76
6.1.4	Integrated circuit (IC) sensors	76
6.2	Photodiode characteristics	76
6.2.1	Junction capacitance	76
6.2.2	Dark current	77
6.2.3	Sensitivity	77
6.2.4	Spectral response	77
6.2.5	Packaging	77
6.3	Optical Concerns	79
6.3.1	Optical filtering	79
6.3.2	Optical interference	79
6.4	Amplifiers	79
6.4.1	Standard transimpedance amplifier configuration	80
6.4.2	Differential transimpedance amplifier	82
6.4.3	Zeroing circuit	83
6.4.4	Future trends	84
	References	84
	Instructional objectives	84
7	PROBES	86
	<i>Moola Venkata Subba Reddy</i>	
7.1	Transmittance Probes	
7.1.1	Principle	86
7.1.2	Sensor placement	87
7.2	Reflectance Probes	87
7.2.1	Principle	88
7.2.2	Sensor placement	88
7.2.3	Effect of multiple photodiode arrangement	90
7.2.4	Effect of skin temperature	90
7.2.5	Advantages and disadvantages of reflectance probes over transmittance probes	91
7.3	MIR probes	91
7.4	Probe connectors	92
7.5	Reusable probes	93
7.6	Disposable probes	94
7.7	Sources of errors due to probes and placement	94
7.7.1	Ambient light interference	94
7.7.2	Optical shunt	95
7.7.3	Edema	95
7.7.4	Nail Polish	95
	References	96
	Instructional objectives	96

8	ELECTRONIC INSTRUMENT CONTROL <i>Ketan S Paranjape</i>	97
8.1	General theory of operation	97
8.1.1	Historic perspective	98
8.2	Main block diagram	99
8.2.1	Input module	100
8.3	Digital processor system	101
8.3.1	Microprocessor subsection	101
8.3.2	General block description	102
8.3.3	Wait state generator	103
8.3.4	Clock generator, timer circuit and UART	103
8.3.5	Pattern generator	104
8.4	Analog processing system (Nellcor®)	105
8.4.1	Analog signal flow	105
8.4.2	Coding resistor, temperature sensor, and prefiltering	105
8.4.3	Preamplifier	105
8.4.4	Demodulator and filtering	106
8.4.5	DC offset elimination	107
8.4.6	Timing diagram (Nellcor®)	109
8.4.7	LED driver circuit	110
8.4.8	Analog processing system (Ohmeda®)	111
8.5	ECG section	113
8.5.1	Active filters	114
8.5.2	Offset amplifiers	114
8.5.3	Detached lead indicator	114
8.5.4	Power line frequency sensing	115
8.5.5	ECG output	115
8.6	Signal conversion	116
8.6.1	Analog-to-digital conversion technique	116
8.6.2	Digital-to-analog conversion	117
8.6.3	Sample-and-hold circuit	117
8.7	Timing and control	117
8.7.1	Polling and interrupt	117
8.8	Power Supply	118
8.9	Alarms	119
8.10	Storage	119
8.11	Front end display	120
8.11.1	Front end driver circuit	120
8.11.2	Front panel control	121
8.11.3	Power up display tests	121
8.12	Speakers	121
	References	122
	Instructional objectives	122
9	SIGNAL PROCESSING ALGORITHMS <i>Surekha Palreddy</i>	124
9.1	Sources of errors	124
9.2	Beer-Lambert law	125

9.2.1	Estimation of oxygen saturation using the Beer-Lambert law	126
9.3	Ratio of ratios	129
9.3.1	Peak and valley method	129
9.3.2	Derivative method: noise reduction software	130
9.4	General processing steps of oximetry signals	133
9.4.1	Start up software	134
9.5	Transient conditions	135
9.6	ECG synchronization algorithms	143
9.6.1	Nellcor <sup>®</sup> system	144
9.6.2	Criticare <sup>®</sup> system	149
9.7	Spectral methods of estimating $S_pO_2$	157
	References	158
	Instructional objectives	158
10	<b>CALIBRATION</b>	159
	<i>Jeffrey S Schowalter</i>	
10.1	Calibration methods	159
10.1.1	Traditional <i>in vivo</i> calibration	159
10.1.2	<i>In vitro</i> calibration using blood	162
10.2	Testing simulators	163
10.2.1	Simulators using blood	164
10.2.2	Nonblood simulators	168
10.2.3	Electronic simulators	173
10.3	Standards	172
10.3.1	ASTM F1415	173
10.3.2	ISO 9919	173
10.3.3	Other standards	174
	References	174
	Instructional objectives	175
11	<b>ACCURACY AND ERRORS</b>	176
	<i>Supan Tungjitkusolmun</i>	
11.1	Evaluation of pulse oximeters	176
11.1.1	Accuracy, bias, precision, and confidence limit	177
11.1.2	What do pulse oximeters really measure?	178
11.1.3	Pulse oximeter versus CO-oximeter	179
11.1.4	Pulse oximeter versus <i>in vivo</i> eight-wavelength ear oximeter	179
11.2	Accuracy versus saturation	180
11.2.1	High saturation (greater than 97.5%)	180
11.2.2	Normal saturation (90 to 97.5%)	181
11.2.3	Low saturation (less than 90%)	181
11.3	Accuracy versus perfusion	182
11.3.1	Venous congestion	182
11.4	Accuracy versus motion artifacts	183
11.5	Accuracy versus optical interference	184
11.6	Accuracy versus intravenous dyes	185

11.7	Effect of dyshemoglobins and fetal hemoglobin	187
11.7.1	Carboxyhemoglobin (COHb)	187
11.7.2	Methemoglobin (MetHb)	188
11.7.3	Fetal hemoglobin	189
11.7.4	Bilirubin	190
11.8	Effect of temperature	190
11.8.1	Ambient temperature	190
11.8.2	Patient temperature	191
11.9	Accuracy versus medical conditions	192
11.9.1	Cardiac arrhythmia	192
11.9.2	Myxoma	192
11.10	Accuracy versus probe position	193
11.11	Electromagnetic interference	194
11.11.1	Interference from magnetic resonance imaging (MRI)	194
11.12	Other effects on accuracy	195
11.12.1	Exercise	195
11.12.2	Dried blood	196
11.12.3	Pigments	196
	References	197
	Instructional objectives	198
12	USER INTERFACE FOR A PULSE OXIMETER	199
	<i>Albert Lozano-Nieto</i>	
12.1	Introduction	199
12.2	Front Panel	200
12.2.1	Graphical displays	201
12.2.2	Numerical displays	203
12.3	Function controls	204
12.4	Alarm controls	206
12.5	Communicative functions	209
12.6	Cables and Connectors	210
12.7	Other features	210
12.8	Compliance requirements	211
	References	212
	Instructional objectives	213
13	APPLICATIONS OF PULSE OXIMETRY	214
	<i>Joanna B Ruchala</i>	
13.1	Anesthesia	214
13.1.1	Problems encountered during induction to anesthesia	215
13.1.2	Surgery under anesthesia	216
13.2	Monitoring tissue blood supply and organ viability	217
13.2.1	Intestinal blood flow and bowel viability following surgery	217
13.2.2	Tissue transfer and setting of limb fractures	218
13.2.3	Dental pulp blood supply and viability	218
13.3	Monitoring on the road and in the air	219

13.3.1	Ambulances	219
13.3.2	Flight	220
13.4	Childbirth	221
13.4.1	Causes of desaturation in mother and fetus	221
13.4.2	Special apparatus for fetal monitoring	222
13.5	Neonatal and pediatric care	224
13.6	Sleep studies and physical stress testing	227
13.6.1	Sleep	227
13.6.2	Exercise	231
13.7	Management of cardiopulmonary resuscitation	231
13.8	Computer-controlled oxygen weaning	232
13.9	Systolic blood pressure measurement	232
13.10	Cerebral oxygen measurement	232
13.11	Veterinary care	233
13.12	Future improvements for pulse oximetry	234
	References	234
	Instructional objectives	236
	<b>GLOSSARY</b>	<b>237</b>
	<b>INDEX</b>	<b>243</b>

## PREFACE

---

Pulse oximetry was introduced in 1983 as a noninvasive method for monitoring the arterial oxygen saturation of a patient's blood. Recognized worldwide as the standard of care in anesthesiology, it is widely used in intensive care, operating rooms, emergency, patient transport, general wards, birth and delivery, neonatal care, sleep laboratories, home care and in veterinary medicine. It provides early information on problems in the delivery of oxygen to the tissue. Those problems may arise because of improper gas mixtures, blocked hoses or airways, inadequate ventilation, diffusion, or circulation, etc. More than 35 companies manufacture and distribute the more than 300 000 pulse oximeters presently in use in the USA.

This book emphasizes the design of pulse oximeters. It details both the hardware and software required to fabricate a pulse oximeter as well as the equations, methods, and software required for effective functioning. Additionally, it details the testing methods and the resulting accuracy. The book should be of interest to biomedical engineers, medical physicists, and health care providers who want to know the technical workings of their measuring instruments.

Chapter 1 reviews the methods of transport of oxygen to the tissue by ventilation, perfusion to the blood, binding to hemoglobin in the red blood cells, and transport through the blood circulation. Chapter 2 describes the problems and diseases that can occur in oxygen transport, which motivate us to measure oxygenation. In chapter 3, we review the many ways oxygenation has been measured in the past, the CO-oximeter used as the gold standard, and provide an introduction to the pulse oximeter.

Chapter 4 begins with Beer's law for the absorption of light by hemoglobin and oxyhemoglobin, and develops the equations required for converting measured light transmission through the tissue to display the hemoglobin oxygen saturation. The light-emitting diodes, which alternately emit red light at 660 nm and infrared light at 940 nm and require precise wavelength control, are described in chapter 5. Chapter 6 covers the variety of light sensors, with emphasis on the single photodiode typically used.

Chapter 7 details the design of reusable and disposable probes and their flexible cables. The probes can transmit light through either the finger or ear, or use reflected light from the scalp or other skin surface. Chapter 8 covers the hardware, with block diagrams showing how red and infrared signals are amplified to yield the ratio of pulse-added red absorbance to the pulse-added infrared absorbance. These signals are used to control light-emitting diode levels and the ratio is used to calculate oxygen saturation. The flow charts and



algorithms to perform oxygen saturation calculations are given in chapter 9, with worked out examples. Synchronization with the electrocardiogram improves accuracy during patient movement.

Chapter 10 describes ways to test performance of pulse oximeters: the technician's finger, electronic simulators, *in vitro* test systems, and optoelectronic simulators. In chapter 11, we find the resulting accuracies and descriptions of the inaccuracies caused by alternative forms of hemoglobin, optical and electrical interference, colored nail polish, etc. Chapter 12 describes the interface between the pulse oximeter, the operator, and the external world. Chapter 13 covers the many applications for pulse oximetry in intensive care, operating rooms, emergency, patient transport, general wards, birth and delivery, neonatal care, sleep laboratories, home care, and in veterinary medicine.

A glossary provides definitions of terms from both the medical and the engineering world. We also provide instructional objectives as a means of provoking further thought toward learning the information. We gleaned much of the design information from operator's manuals and from patents; periodical literature provided more general information. Rather than giving an exhaustive list of references, we have included review articles and books that can serve as an entry into further study. All contributors are from the Department of Electrical and Computer Engineering at the University of Wisconsin, Madison, WI, USA, and worked as a team to write this book. We would welcome suggestions for improvement of subsequent printings and editions.

**John G. Webster**

Department of Electrical and Computer Engineering  
University of Wisconsin-Madison  
Madison WI, USA  
August 1997

## CHAPTER 1

---

# NORMAL OXYGEN TRANSPORT

*Susanne A Clark*

Oxygen is vital to the functioning of each cell in the human body. In the absence of oxygen for a prolonged amount of time, cells will die. Thus, oxygen delivery to cells is an important indicator of a patient's health.

Several methods have been developed to analyze oxygen delivery. Pulse oximetry is a common, noninvasive method used in clinical environments. This book discusses pulse oximetry, from applications to signal processing. Before continuing, it is essential to understand normal oxygen transport, which is the subject of this chapter.

Oxygen delivery to cells requires the use of the respiratory system as well as the circulatory system. Ventilation is the initial step, moving air into and out of the lungs. Within the lungs, gas exchange occurs. Oxygen is diffused into the blood, while carbon dioxide, a byproduct of cellular respiration, diffuses into the lungs. The oxygenated blood circulates around the body until it reaches oxygen depleted areas, where oxygen is diffused to cells, and carbon dioxide is transferred to the blood returning to the lungs. The ventilatory process is controlled by neurons in the brain stem. The circulatory system also can modulate cardiac output to effect the oxygen delivery.

### 1.1 VENTILATORY CONTROL

Ventilation is the involuntary, rhythmic process of moving air in and out of the lungs. This process is controlled by respiratory neurons in the brain stem. The respiratory neurons excite motor neurons, which in turn cause the movement of respiratory muscles. The output of the respiratory neurons is modulated by *chemoreceptors* and *mechanoreceptors*.

#### *1.1.1 Neural control*

The respiratory neurons in the brain stem are responsible for the pattern generation in normal breathing. The rate and depth of *ventilation* are modulated by these neurons. The respiratory neurons excite motor neurons in the spinal cord. The excitation of the motor neurons causes the contraction of the diaphragm, pectoral muscles, and intercostal muscles. All of these muscles

combine efforts pulling the ribcage up and out, expanding the lungs, causing inspiration. The activity of respiratory neurons is thought to occur spontaneously, with occasional inhibition allowing the respiratory muscles to relax. This causes the rib cage to contract which yields expiration.

### *1.1.2 Respiratory feedback*

The brain stem receives feedback from many mechanical and chemical receptors. The input from these neurons is analyzed by the respiratory neurons to determine the appropriate rate and depth of ventilation. Mechanoreceptors give feedback related to mechanical aspects of breathing. For example, stretch receptors are mechanoreceptors that provide feedback on the expansion of the lung and chest during both inspiration and expiration. An inflation index is the level of feedback provided that causes inhibition of inspiration, preventing overinflation of the lungs. A deflation index serves a similar purpose in expiration, hindering the collapse of the lungs.

Chemoreceptors provide information on the level of carbon dioxide, oxygen, and hydrogen ions in the blood. Chemoreceptors are located in the carotid arteries, as the oxygenated blood is being sent to the brain, and in the aorta, shortly after the oxygenated blood is being pumped from the heart to the body. Oxygen levels under normal conditions are high in the systemic arteries, and carbon dioxide and hydrogen levels are low.

The brain stem must process all of the information it receives and no single factor controls ventilation. Under normal breathing conditions, the brain stem is most sensitive to the levels of carbon dioxide and hydrogen. The oxygen concentrations are only important when the level is extremely low. Consider an extremely high level of carbon dioxide present in the blood, such as would occur during maximal exercise. However, stretch receptors indicate that the lung and chest are at maximal expansion, meaning the inflation index has been reached. Thus, the rate of breathing increases to compensate without a proportional increase in chest and lung expansion.

An unusual feature of ventilation is that breathing can be brought under voluntary control to some extent. However, it is not possible to commit suicide by refusing to breathe. Once the individual loses consciousness, the input from chemoreceptors will cause ventilation to be restored.

## 1.2 VENTILATORY MECHANICS

Ventilatory mechanics are based on the principle of air flow from areas of high pressure to areas of lower pressure. The contraction of the intercostal muscles, pectoral muscles, and the diaphragm causes the thoracic cavity to expand, decreasing the pressure in the thoracic cavity. The atmospheric pressure is higher than the pressure inside the lungs, causing air to flow into the lungs, which is termed inspiration. The relaxation of the intercostal muscles and the diaphragm causes the volume of the lungs to decrease, increasing the pressure in the thoracic cavity. As the pressure in the lungs increases reaching levels above the atmospheric pressure, air flows out of the lungs, which is referred to as expiration.

### 1.2.1 Inspiration

As discussed previously, the brain stem excites motor neurons in the spinal cord, which, in turn, causes the contraction of the diaphragm, the pectoral muscles, and intercostal muscles, located between the ribs. The contraction of the diaphragm causes the flattening and lengthening of the thoracic cavity. The intercostal muscles and pectoral muscles pull the ribcage up and out. Both of these sets of muscles work to expand the lungs. This means that pressure will be reduced within the lungs, since the air present will have a greater volume to expand in. This will create a pressure differential between the air outside the body and the air inside the body. Thus, air flows into the body (see figure 1.1(a)).

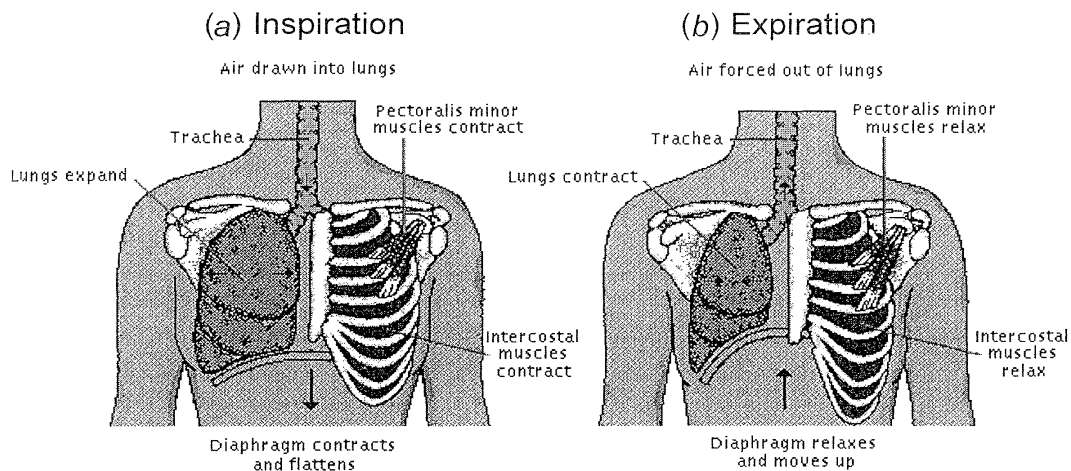

**Figure 1.1** During inspiration, (a), the diaphragm, intercostal muscles and pectoralis minor muscles contract, causing the lungs to expand and air to enter the lungs. As the diaphragm, intercostal muscles and pectoralis minor relax, the lungs contract, causing air to leave the lungs (b), which is referred to as expiration (from Microsoft Encarta).

Air travels through the nasal cavity. Cilia are microscopic hairs within the nasal cavity that act to eliminate pollutants from entering the respiratory tract. Air and food both go through the *pharynx*. When food is swallowed, the epiglottis (part of the *larynx*), pharynx, and mouth cavity work together to shut off the opening to the trachea to avoid the entry of food particles into the lungs.

The larynx is commonly referred to as the voice box. Besides assisting with separation of food particles from air, the larynx contains the cricoid cartilage which reinforces the airway and assists in keeping it open. The larynx also contains the vocal cords. As air vibrates over the vocal cords, a sound is produced. The variation in elasticity and tension of the vocal cords determines the pitch of the sound.

The trachea is composed of ribbed cartilage which extends 10 cm to the bronchi. The trachea also contain cilia which act to filter out further pollutants. Two *bronchi* provide a path to each *lung* (see figure 1.2).

Each bronchus divides into even narrower *bronchioles*. Each bronchiole has five or more *alveolar ducts* at the end, which, in turn, end in *alveolar sacs*. Each alveolar sac contain several *alveoli* (see figure 1.3). Alveoli are the site of gas exchange.

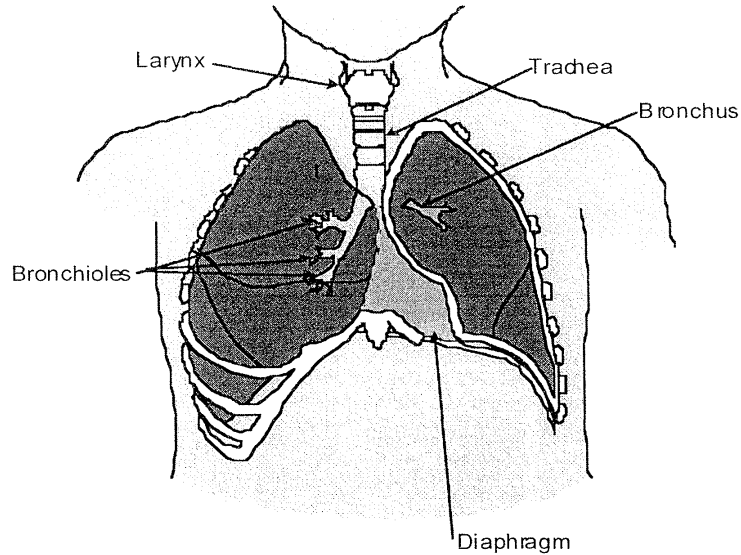

**Figure 1.2** Air travels through the nasal cavity, into the pharynx, trachea, bronchi, and finally the lungs. The bronchi, bronchioles, alveolar ducts and alveoli compose the pulmonary tree with its branch like system (adapted from Corel Corporation).

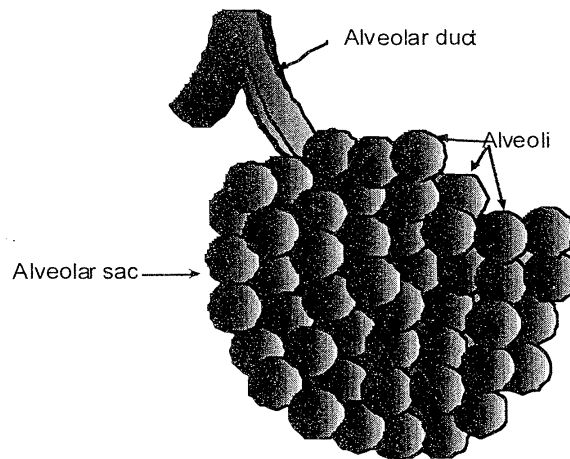

**Figure 1.3** Ten or more alveoli are in one alveolar sac (adapted from Corel Corporation).

### *1.2.2 Expiration*

Neurons in the brain stem cyclically inhibit the motor neurons in the spinal cord that cause muscle contraction in the diaphragm, the pectoral muscles, and intercostal muscles. The muscles then relax, causing the rib cage to contract, decreasing the amount of air space. This causes air to flow out of the lungs when the pressure inside the lungs is greater than the pressure outside the lungs (see figure 1.1(b)). Usually only 10% of the total lung volume is exchanged in normal breathing. With deeper, more rapid breathing, the turbulence of the air flow increases, causing greater resistance to airflow.

### 1.3 DIFFUSION TO BLOOD

The process of ventilation provides a continuous supply of fresh air in the lungs. After oxygenated blood has been circulated through the body, it is brought back to the lungs through arterial capillaries to exchange gases, receiving oxygen and ridding itself of carbon dioxide. Blood is reoxygenated and is then recirculated through the body.

Gas exchange occurs through the process of diffusion. *Diffusion* is the net movement of particles from an area of higher *partial pressure* to a region of lower partial pressure through a process of random motion. The actual gas exchange to the blood takes place through the process of diffusion in the *alveoli*.

#### 1.3.1 The alveoli

The alveoli are surrounded by large *pulmonary* capillary beds. Since diffusion can only occur over a distance of 1 mm, the gas exchange takes between the two cells between the capillary and the alveolus, a distance of only 0.5  $\mu\text{m}$ . The 600 million alveoli each adult has provide 70  $\text{m}^2$  of surface area for gas exchange (Curtis and Barnes 1989).

#### 1.3.2 Gas exchange

Air in the alveoli has a higher partial pressure of oxygen and a lower partial pressure of carbon dioxide than the aortic blood. The pressure gradient causes diffusion to occur. The net movement of carbon dioxide will be towards the alveoli and the net movement of oxygen towards the blood (see figure 1.4). The blood then returns to the heart via a pulmonary venule to be pumped out to the rest of the body. Other gases may diffuse as a result of the partial pressure gradient between the air in the alveoli and the pulmonary arterial blood.

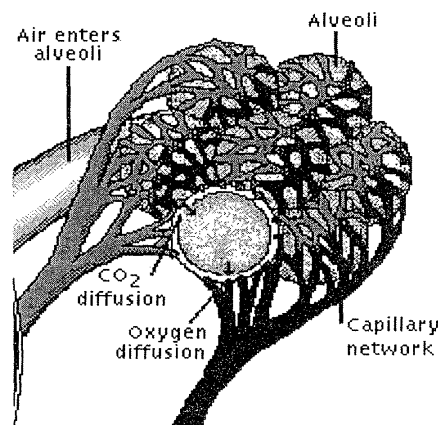

**Figure 1.4** The capillaries surround the alveoli, providing the close proximity necessary for diffusion. Carbon dioxide diffuses from the capillary into the alveoli and oxygen diffuses into the blood (from Microsoft Encarta).

The partial pressure gradient of arterial (a) versus alveolar (A) pressure is affected by the concentration of carbon dioxide and water in the alveoli. The alveolar partial pressure of oxygen is

$$P_{A}O_2 = (P_{\text{atm}} - P_{H_2O})F_iO_2 - P_aCO_2/0.8 \quad (1.1)$$

where atmospheric pressure  $P_{\text{atm}}$  is typically 760 mm Hg (101 kPa), the water vapor pressure  $P_{H_2O}$  is 47 mmHg (6.3 kPa) at 37 °C, the fraction of inspired  $O_2$ ,  $F_iO_2$  is 0.21 with room air,  $P_aCO_2$  is the arterial carbon dioxide partial pressure, and 0.8 is the normal *respiratory quotient*. The respiratory quotient is the ratio of volume of  $CO_2$  produced per volume of  $O_2$  consumed.

The rate of gas movement is determined by the pressure gradient, temperature and path length over which the gas exchange occurs. This is defined as

$$\dot{V} = \frac{T\Delta P}{L} \times D \quad (1.2)$$

where  $\dot{V}$  is the volume rate of gas exchange,  $\Delta P$  is the pressure gradient,  $T$  is the absolute temperature,  $L$  is the path length, and  $D$  is a diffusion coefficient for a specific material.

In a living adult, it is not realistic to measure the path length or surface area. Thus, a diffusing capacity of the lung is defined to provide a quantitative measure of the effectiveness of *respiration*. This is defined as

$$D_L = \frac{\dot{V}}{\Delta P} \quad (1.3)$$

where  $D_L$  is the diffusing capacity of the lung (Ruch and Patton 1965).

## 1.4 BIND TO HEMOGLOBIN

Gases are not particularly soluble in blood, which is composed mostly of water. Thus, for effective oxygen transport, a secondary method of transport is required. The compound hemoglobin provides a binding mechanism that allows oxygen to be transported through the blood. *Hemoglobin* plays an essential role in transporting the necessary amount of oxygen to the body. For the same amount of plasma, 65 times more oxygen can be transported with hemoglobin than would be possible without hemoglobin.

### 1.4.1 Characteristics of hemoglobin

Hemoglobin is a respiratory pigment contained within red blood cells. One red blood cell contains approximately 265 million molecules of hemoglobin (Curtis and Barnes, 1989). Hemoglobin is composed of *heme* units, which are molecules containing iron, and *globin* units, *polypeptide* chains. One hemoglobin molecule contains four heme and four globin units. Each hemo and globin unit can carry one molecule of oxygen. Thus, one hemoglobin molecule can carry four molecules of oxygen (see figure 1.5).

As respiratory pigment, hemoglobin changes color when oxygenated. An oxygenated hemoglobin molecule is bright red, while a deoxygenated hemoglobin molecule, a hemoglobin molecule without oxygen, is dark red. This color change is used in the application of pulse oximetry to measure hemoglobin oxygen saturation.

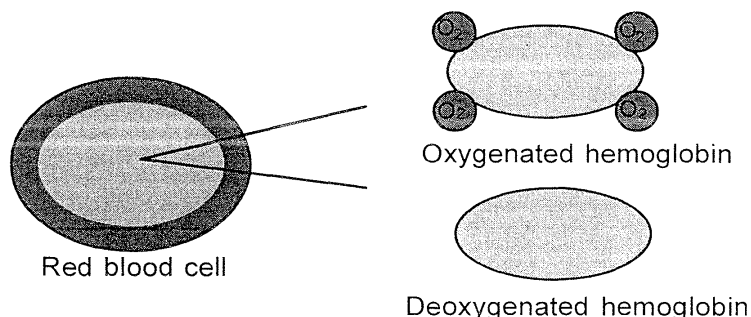
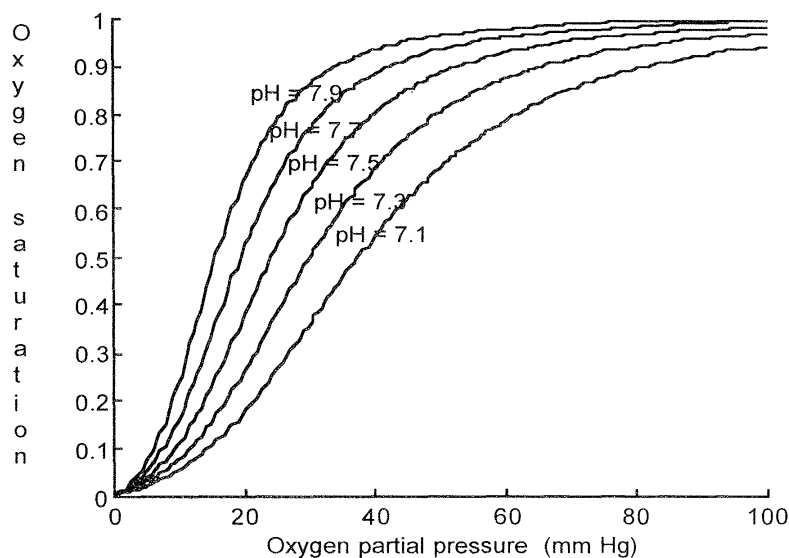

**Figure 1.5** Hemoglobin molecules are contained within red blood cells. Each red blood cell contains approximately 265 million molecules of hemoglobin.

After a completely deoxygenated hemoglobin molecule combines with one oxygen molecule, it has a greater affinity for the second oxygen molecule. This is true for each additional oxygen molecule. The reverse process is also true. After the first oxygen molecule is released from the hemoglobin molecule, it is more likely to release the second oxygen molecule. Therefore, the oxyhemoglobin dissociation curve, which relates to the partial pressure of oxygen in the blood, is not a straight line, but a sigmoid.

#### 1.4.2 Oxyhemoglobin dissociation curves

The oxyhemoglobin dissociation curve is the relationship between the partial pressure of oxygen in the blood and the percentage of oxygen bound to hemoglobin compared to the maximum (see figure 1.6). Factors such as decreasing carbon dioxide concentration, increasing pH, and decreasing temperature will shift the curve toward the left. A left-shifted curve implies that the hemoglobin molecules will be more saturated at a lower partial pressure of oxygen.



**Figure 1.6** Increasing pH causes the oxyhemoglobin dissociation curve to shift to the left at a constant temperature of 37 °C.



A fetus has a oxyhemoglobin dissociation curve that is to the left of the mother's. This means that the fetus has a greater affinity for oxygen and will take oxygen from the mother's blood to meet its own need.

The volume of oxygen carried by hemoglobin per 100 mL of blood can be defined as follows:

$$C_{\text{HbO}_2} = 1.37 \times \text{Hb} \times S_a\text{O}_2 \quad (1.4)$$

where  $C_{\text{HbO}_2}$  is the volume of oxygen carried by hemoglobin per unit of 100 mL of blood and is typically around 19 mL O<sub>2</sub>/100 mL blood, 1.37 is the number of mL of oxygen bound to 1 g of fully saturated hemoglobin, Hb is the weight of hemoglobin, typically around 14 g Hb/100 mL blood, and  $S_a\text{O}_2$  is the percentage of saturation of hemoglobin in arterial blood (Payne and Severinghaus 1986).

### 1.5 DISSOLVED IN PLASMA

Most of the oxygen transported by the body is bound to hemoglobin, but some oxygen is also dissolved in plasma. The total oxygen content of the blood is the sum of the bound oxygen and the dissolved oxygen.

Hemoglobin increases the amount of oxygen transported to the body by 65 times the amount carried by a specified volume of blood, but some oxygen is still carried dissolved in plasma. The volume of dissolved oxygen per 100 mL of blood is defined as

$$C_{\text{D}\text{O}_2} = 0.003P_a\text{O}_2 \quad (1.5)$$

where  $C_{\text{D}\text{O}_2}$  is the volume of dissolved oxygen in blood, 0.003 is the solubility of oxygen in blood as the percent by volume per mmHg, and  $P_a\text{O}_2$  is the partial pressure of oxygen in the arteries.  $C_{\text{D}\text{O}_2}$  is typically around 0.3 mL O<sub>2</sub>/100 mL blood. It is significantly smaller than the bound oxygen content of blood, typically 19 mL O<sub>2</sub>/100 mL blood. The oxygen content of the blood is the sum of the oxygen bound to hemoglobin and the oxygen dissolved in the plasma:

$$C_{\text{A}\text{O}_2} = C_{\text{HbO}_2} + C_{\text{D}\text{O}_2} \quad (1.6)$$

### 1.6 CIRCULATION

Once oxygen has been diffused to the blood, it is returned the heart. The *circulatory system* serves to transport oxygenated blood to the cells in the body. The heart is the primary pumping mechanism for transporting blood through the body.

#### 1.6.1 The heart

Blood is pumped through body by the heart. The contraction of the heart is controlled by a series of electrical impulses, originating from the sinoatrial node (SA node) and travels to the atrioventricular node (AV node), causing the polarization and depolarization of the muscle fibers of the heart. These electrical impulses can be recorded as the electrocardiogram (see figure 1.7).

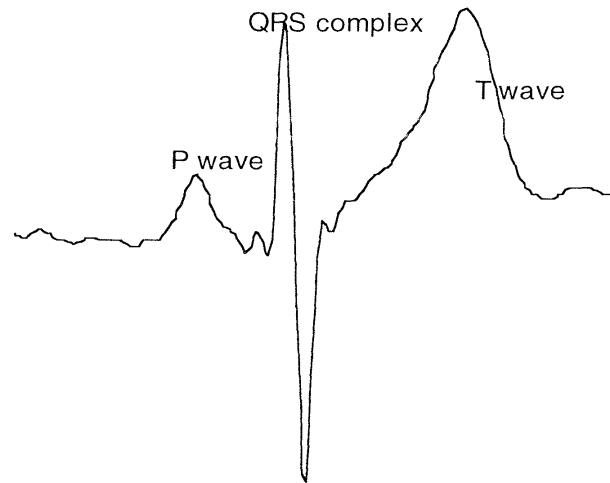

**Figure 1.7** The P wave is caused by the depolarization of the atrial fibers just prior to contraction. The QRS complex is caused by the depolarization of the ventricles, causing the contraction of the ventricles. The T wave is caused by the polarization of the ventricles as the muscles relax. The polarization of the atrial fibers occurs simultaneously with the QRS complex and is obscured by the contraction of the larger muscle fibers in the ventricles. The peak of the QRS complex is the R wave. The R–R interval between consecutive heartbeats is used to calculate the heart rate.

### 1.6.2 Pulmonary circulation

The heart serves as the pumping mechanism for the blood. Blood that is oxygen depleted is pumped from the right *ventricle* of the heart to the lungs. The pulmonary arteries branch into smaller arterioles and eventually into arterial capillaries, which have a thickness of only one cell. This is where gas exchange occurs between the alveoli and the capillaries and blood is reoxygenated. Blood is then returned via pulmonary ventral capillaries to larger venules and eventually pulmonary veins. The pulmonary veins return blood to the left *atrium* of the heart.

### 1.6.3 Systemic circulation

Reoxygenated blood is returned to the heart in the left atrium. It is then pumped from the left ventricle via the *systemic* arteries to the body. Blood pressure within the arteries varies throughout a single heartbeat, reaching a maximum at systole, caused by the contraction of the ventricles, and a low at diastole, after the ventricles have relaxed. The systemic arteries also branch into smaller arterioles and even smaller capillaries. Oxygen is then exchanged with the tissues of the body. The blood, depleted of oxygen, is then returned via venal capillaries, venules, and veins to the right atrium of the heart where it is again reoxygenated (see figure 1.8).

### 1.6.4 Cardiac output

Mechanical and chemical stimuli are processed in the brain and provide feedback to the SA node and the AV node which control heart rate and stroke volume. The *cardiac output* (CO) of the heart is the product of the stroke volume (SV) and the

heart rate (HR). The *cardiac index* (CI) is the cardiac output normalized by *body surface area* (BSA). A typical CI is in the range of 3 to 3.4 L/(min m<sup>2</sup>). Normalization of the cardiac output allows comparisons related to circulation of people of varying sizes.

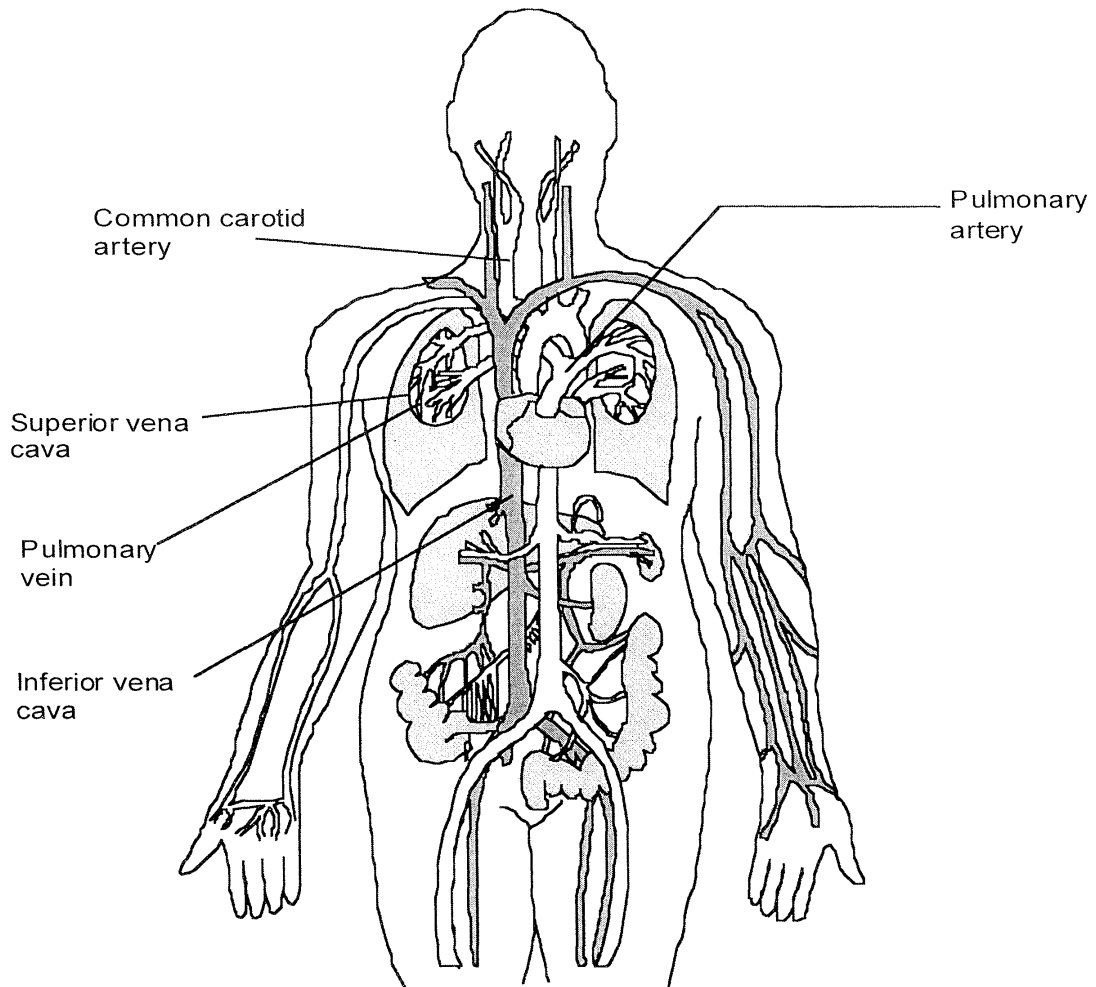

**Figure 1.8** The right atrium receives blood from two veins, the superior vena cava and the inferior vena cava. The right ventricle pumps blood through the pulmonary artery, which sends the blood to the lungs to be oxygenated. The oxygenated blood returns to the heart via the pulmonary veins, where it is pumped by the left ventricle to be distributed to the rest of the body (adapted from Corel Corporation).

### 1.7 DIFFUSION TO TISSUE

Diffusion occurs over a distance of about 1 mm. Thus, once blood is oxygenated, although it may pass through oxygen depleted tissue, oxygen does not diffuse until it reaches the capillaries with one cell thickness in the wall. Oxygen diffuses into the *interstitial fluid* and into the cells.

### 1.7.1 Diffusion into interstitial fluid and cell

Once blood reaches the systemic capillaries, the surrounding tissue usually has a lower partial pressure of oxygen than that of the blood. Oxygen diffuses into the surrounding tissue. When the tissue has a higher metabolic rate, the difference in partial pressure is greater, and more oxygen is released using the steep part of the oxyhemoglobin dissociation curve. While oxygen diffuses into the interstitial fluid, carbon dioxide diffuses into the blood. Once the oxygen is near the cell, it diffuses through the cell membrane.

### 1.7.2 Oxygen delivered

The oxygen delivery index ( $D_1O_2$ ) is defined as

$$D_1O_2 = C_aO_2 \times CI \times 10 \quad (1.7)$$

which is typically 550 to 650 mL/(min m<sup>2</sup>). This is a measure of the amount of oxygen available to tissue. The oxygen consumption is a measure of the oxygen diffused into the tissue. It is defined as

$$CI \times (C_aO_2 - C_vO_2) \quad (1.8)$$

where  $C_vO_2$  is the oxygen content of the venous blood. A normal value for oxygen delivery is 115 to 165 mL/(min m<sup>2</sup>). This means that not all of the available oxygen diffuses into the tissue (Payne and Severinghaus 1986).

### 1.7.3 Myoglobin

*Myoglobin* is a respiratory pigment found in muscles, which is responsible for the reddish brown color of the muscle cells. It has a greater affinity for oxygen than hemoglobin, its oxyhemoglobin dissociation curve is left-shifted, and will not release oxygen under the same conditions as hemoglobin in the blood. Only when the partial pressure of oxygen in the surrounding tissue is below 20 mmHg, such as in exercise, does myoglobin release its stored oxygen. Thus, myoglobin reduces the need for oxygen delivery to muscle tissue beds under extreme conditions, but can only supply a limited amount of oxygen for a short period of time (Hole 1981).

## 1.8 USE IN CELL

The purpose of respiration is to bring oxygen to cells for cellular respiration. The cells then use oxygen to in turn generate energy. Although a cell may survive for a short time without oxygen, producing energy through anaerobic methods, each individual cell must have oxygen.

Cellular respiration involves the breakdown of molecules, glucose, and releasing energy from them. This process involves oxidation and reduction chemical reactions. *Oxidation* is the loss of an electron, releasing energy, and *reduction* is the gain of an electron. Oxygen atoms serve to attract electrons. Oxygen is needed by the cell to oxidize glucose to release energy. The simplified

equation for the complex chemical reactions, involving the *Kreb's Cycle*, taking place is

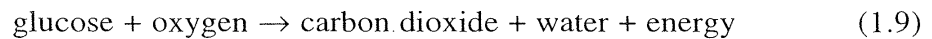

where carbon dioxide and water are byproducts of the chemical reaction. Energy is released in the form of *ATP*, a source of cellular energy used in various metabolic processes, and heat, which is lost.

## REFERENCES

- Curtis H and Barnes N S 1989 *Biology*. 5th edn (New York: Worth)  
 Hole J W Jr 1981 *Human Anatomy and Physiology* 2nd edn (Iowa: Brown)  
 Payne J P and Severinghaus J W (eds) 1986 *Pulse Oximetry* (New York: Springer)  
 Ruch T C and Patton H D (eds) 1965 *Physiology and Biophysics* 19th edn (Philadelphia, PA: Saunders)

## INSTRUCTIONAL OBJECTIVES

- 1.1 Describe how the body accommodates for the increased demand for oxygen during exercise.
- 1.2 Describe how the respiratory system provides for gas exchange.
- 1.3 Describe the cardiovascular system and its role in transporting oxygen.
- 1.4 Explain the difference between oxygen content, oxygen saturation, and partial pressure of oxygen.
- 1.5 Describe the oxyhemoglobin dissociation curve, and factors which can shift the curve.
- 1.6 Describe the process of diffusion and its role in respiration.
- 1.7 Describe the neurological control of ventilation.
- 1.8 Explain why hemoglobin is required for oxygen transport.
- 1.9 Given alveolar gas concentration, calculate  $P_aO_2$ .
- 1.10 Given  $P_aO_2$ ,  $S_aO_2$ , Hb, calculate  $C_aO_2$ .
- 1.11 Write the chemical equation for the use of oxygen in the cell.
- 1.12 Describe the muscles used for ventilation.
- 1.13 Describe the air flow resistance between the alveoli and the mouth.

## CHAPTER 2

---

# MOTIVATION OF PULSE OXIMETRY

*Daniel J Sebald*

Pulse oximeters have been commercially available for a little more than the last decade and have seen a tremendous growth in popularity becoming a quasi-standard, if not standard, monitoring device in hospital critical care units and surgical theaters. The instrument transcutaneously estimates oxygen saturation of arterial blood and provides vital information about the cardiorespiratory function of the patient. Pulse oximetry provides an empirical measure of arterial saturation. However, with state-of-the-art instrumentation and proper initial calibration, the correlation between the pulse oximeter measurement,  $S_pO_2$ , and arterial blood's actual oxygen saturation,  $S_aO_2$ , is adequate—generally less than 3% discrepancy provided  $S_aO_2$  is above 70% (Severinghaus and Kelleher 1992)—for medical applications where detecting hypoxemia is essential. Quick acceptance of pulse oximetry as a monitoring device for surgery, recovery, critical care and research has shown that for determining hypoxemia any reasonably small loss in accuracy that may be attributed to measuring arterial oxygen saturation transcutaneously is outweighed by the advantages of noninvasiveness and continuous, immediate availability of data. In applications where accuracy is paramount, such as in detecting hyperoxia, the use of pulse oximetry is not so clear and remains to be decided in the medical community. However, mounting evidence suggests that the pulse oximeter is not very useful in these situations. Nonetheless, the importance of detecting hypoxemia, where pulse oximetry is best suited, is so great that the instrument plays a critical role in medicine despite its limitations.

### 2.1 PULSE OXIMETER PRINCIPLES

A pulse oximeter shines light of two wavelengths through a tissue bed such as the finger or earlobe and measures the transmitted light signal. The device operates on the following principles:

1. The light absorbance of oxygenated hemoglobin and deoxygenated hemoglobin at the two wavelengths is different. To be more precise, the set of associated extinction coefficients for the absorption of light for these wavelengths is linearly independent with great enough variation for adequate sensitivity but not so large that the blood appears opaque to either of the

light sources. This model assumes that only oxygenated and deoxygenated hemoglobin are present in the blood.

2. The pulsatile nature of arterial blood results in a waveform in the transmitted signal that allows the absorbance effects of arterial blood to be identified from those of nonpulsatile venous blood and other body tissue. By using a quotient of the two effects at different wavelengths it is possible to obtain a measure requiring no absolute calibration with respect to overall tissue absorbance. This is a clear advantage of pulse oximeters over previous types of oximeters.
3. With adequate light, scattering in blood and tissue will illuminate sufficient arterial blood, allowing reliable detection of the pulsatile signal. The scattering effect necessitates empirical calibration of the pulse oximeter. On the other hand, this effect allows a transmittance path around bone in the finger.

The principles above, associated issues and design and application of pulse oximeters comprise the better part of this text. The remainder of this chapter concentrates on the role and importance of pulse oximetry and limitations of the device.

## 2.2 $S_pO_2$ AS MONITOR OF HEMOGLOBIN OXYGENATION

Lack of oxygen can quickly lead to irreversible damage to cell tissue having a high metabolic rate, the heart and central nervous system being two examples. Although the human body is surprisingly robust in many ways, the physiological process of sustaining proper cell function via oxygen transport is a delicate and complex control system; one which if altered too significantly could become unstable and insufficient for meeting oxygen tissue demands. To emphasize the importance of proper tissue oxygenation, Table 2.1 lists survival times for different organ beds after the onset of anoxia, or cardiac arrest. Hence, it is important to safeguard against pathological conditions that might lead to improper tissue oxygenation.

**Table 2.1** Organ robustness to anoxia (cardiac arrest), a consequence of metabolic rate and cellular oxygen stores. *Survival* time is the time before cellular damage occurs after total loss of oxygen delivery. *Revival* time is the time before function of the organ can no longer be restored. Revival times are generally four times longer than survival times in most organs except the brain, which has a revival time five times longer than its survival time (adapted from Nunn 1987).

Organ	Survival time after onset of anoxia
Cerebral cortex	less than 1 min
Heart	5 min
Liver and kidney	10 min
Skeletal muscle	2 h

### 2.2.1 Comprehensive approach

Arterial saturation, the variable which pulse oximetry is intended to measure, is just one of several variables a physician will consider when assessing the condition of a patient's cardiopulmonary system. In this regard, the clinician will address the fundamental issue of whether or not body tissue is being properly oxygenated (Vender 1992). This requires a comprehensive approach whereby arterial saturation plays a certain role. It is an extremely important one, but physicians typically do not use  $S_aO_2$  as a sole monitor for pathological oxygenation conditions.

### 2.2.2 Arterial oxygen saturation

Arterial oxygen saturation pertains to blood in the arteries and arterioles throughout the body. This blood is of the same saturation throughout the arterial system. It is at the capillary level that saturation levels change. In a healthy adult, the normal operating range for  $S_aO_2$  is greater than 90%, which corresponds to an arterial partial pressure,  $P_aO_2$ , of 60 to 100 mmHg (Ahrens and Rutherford 1993).

Owing to the complexity of the oxygenation process, it is difficult to address the wealth of uses for arterial saturation in critical care settings, operating rooms, and research laboratories. Physicians are interested in knowing  $S_aO_2$  for a variety of reasons. Sometimes it is for quantitative assessment. Sometimes it serves as an important variable for safeguarding against, although it is not a direct indication of the dangerous condition of low cellular oxygenation. Table 2.2 gives several respiratory problems that might cause low  $S_aO_2$ , but this is by no means a complete list.

**Table 2.2** Respiratory problems that might result in low  $S_aO_2$  (adapted from Des Jardins 1990, Cherniack and Cherniack 1983, and Selecky 1982).

Respiratory problem	Example disease or possible source of problem
Poor lung compliance	Pneumonia, ARDS, fibrosis, emphysema
Increased airway resistance	Asthma, chronic bronchitis, cystic fibrosis
Low pulmonary diffusion capacity	Emphysema, pulmonary alveolar proteinosis
Airway obstruction	Choking, secretions from intubation, obstructive sleep apnea
Ventilatory muscle weakness	Lead poisoning, trauma to phrenic nerve
Increased true venous admixture	Congenital heart disease
Low inspired partial pressure of oxygen	Anesthesia equipment failure, high altitude
Hypoventilation	Acid-base imbalance

### 2.2.3 Hypoxia and hypoxemia

*Hypoxia* means lower than normal tissue oxygenation. *Hypoxemia* means lower than normal blood oxygenation. These are two quite different concepts. Hypoxia refers to the critically dangerous condition where cell function is in jeopardy. Table 2.3 shows different categories of hypoxia. The first category, hypoxic hypoxia, is a consequence of low arterial saturation. Hence, hypoxemia is a dangerous condition. However, it is not necessary that hypoxia exist under conditions of hypoxemia. Likewise, as table 2.3 suggests, hypoxia may occur



when there is no evidence of hypoxemia. Therefore, a clinician carefully interprets results from monitoring blood oxygen content because  $S_aO_2$  and, consequently,  $S_pO_2$  provide *only* a measure of hypoxemia, *not* a measure of hypoxia.

**Table 2.3** Different types of hypoxia (adapted from Bredle 1989, and Des Jardins 1990).

Type of hypoxia	Description
Hypoxic hypoxia	Arterial blood is poorly oxygenated due to low $F_I O_2$ or respiratory disease
Anemic hypoxia	Blood cannot transport adequate oxygen due to hemoglobin abnormalities
Circulatory hypoxia	Cardiac output is low or blood perfusion is inadequate
Histotoxic hypoxia	The tissue is incapable of using otherwise sufficient supplies of oxygen

#### 2.2.4 Role of $S_pO_2$ in avoiding hypoxia

Although monitoring blood oxygen saturation provides only clues to the oxygenation of cells, there is one variable which provides better evidence of hypoxia. That is lactate content of the blood. Energy utilization may take place in an anaerobic environment, and the byproduct of such a process is lactate. However, the anaerobic process is inefficient for generating energy, and cells cannot operate for long in this situation. The presence of lactate is not a problem initially because it may be broken down if oxygen stores are replenished soon enough (Ahrens and Rutherford 1993). Lactic acidosis occurs if this is not the case. This, in turn, affects the pH of blood which influences the cardiac and pulmonary control systems. However, if cardiac output and respiratory rate cannot increase the delivered oxygen, a dangerous situation results.

Although lactic acidosis may be a better indicator of hypoxia than arterial blood saturation, the problem is that lactic acidosis is an after-the-fact occurrence. As pointed out by Vender (1992), cell damage is likely occurring upon noting an increase in lactate. Herein lies the true value of blood saturation measurement. If monitored appropriately, it can help signal dangerous pathological conditions before cell damage occurs. However, as alluded to earlier  $S_pO_2$  (i.e.,  $S_aO_2$ ) alone is not as helpful as when supplemented with measures of cardiac output, functional hemoglobin, blood pressure, heart rate, respiratory rate, urine output, patient comfort and a variety of other variables.

**2.2.4.1 Anesthesiology.** Tissue oxygenation and, consequently, blood saturation are of extreme importance to the anesthesiologist because the patient's cardiopulmonary system is placed in a state where it can no longer meet oxygen demands on its own. In a sense, the anesthetist becomes the controller for the patient's respiratory system, and  $S_pO_2$  provides one of the better feedback variables. As a monitoring device to assist the anesthetist, pulse oximetry has literally revolutionized the field of anesthesiology because of its noninvasive nature, fast response and affordability (Fairley 1989). Note that the transition to pulse oximetry was not without controversy (Payne and Severinghaus 1985). Cyanosis, heart rate and blood pressure were generally what was available to the anesthesiologist for detecting hypoxia before the advent of pulse oximetry (Fairley 1989). Similar to lactate, all these variables are after-the-fact

occurrences of hypoxia. Again,  $S_pO_2$  does not give direct indication of hypoxia, which has its drawbacks, but it can be an early warning of its occurrence.

The most frequent use of pulse oximeters is by anesthesiologists during surgery and for about an hour afterwards in the recovery room. Anesthesiologists administer narcotics to the patient to suppress the central nervous system. This stops the patient's desire to breathe. In addition, they administer muscle relaxants, which stops the ability to breathe and permits airways to collapse. Thus, it is necessary to restore breathing through intubation and artificial respiration. Anesthesiologists can monitor several variables, but most have limitations of late or unreliable response to an oxygenation problem.

Blood pressure declines long after oxygen declines, and the ECG indicates problems even later than blood pressure. An esophageal stethoscope indicates within one beat when the heart has stopped, but this is also long after oxygen has declined. The anesthesiologist can check for cyanosis. Again, this occurs long after oxygen has declined. Blood gas samples give an accurate measurement of oxygen, carbon dioxide, and pH but take about 5 min to process.

Pulse oximeters solved the problem of delay by continuously and noninvasively monitoring arterial oxygen saturation. Recall that adequate arterial saturation does not imply proper oxygenation. Furthermore, there is a delay between noting a drop in  $S_pO_2$  and its cause. However, of the monitored variables,  $S_pO_2$  is currently the best indication that an oxygenation problem exists or is about to occur, and it does so noninvasively.

The pulse oximeter probe is usually applied to the finger, since the body will decrease blood flow to the finger before more vital organs. It is more difficult to reliably secure probes to the ear, nose, and forehead. An arterial oxygen saturation drop from 98 to 96% alerts the anesthesiologist that something is going on. If the oxygen saturation drops to 90%, the default alarm sounds, which indicates that a serious problem may be at hand.

Continuously monitoring  $S_pO_2$  catches several equipment malfunctions and improper placement of tracheal tubes, but naturally it does not identify the problem (Payne and Severinghaus 1985). The fact that  $S_pO_2$  does not identify the source of the problem should not be viewed as a drawback to the pulse oximeter. Instead, this has implications in how to view pulse oximetry as a monitored variable. Fairley (1989) has figuratively stated the role of pulse oximetry in anesthesiology (Original metaphor attributed to Tremper and Barker (1989)):

It was not until effective pulse oximetry became commercially available, for the first time, that large numbers of anesthesiologists could continuously monitor their patients' arterial oxygen levels. It is very important to recognize the nature of this monitoring. Since virtually every anesthetized patient breathes an oxygen enriched mixture, desaturation only occurs when there is a substantial increase in the difference between the (perceived) inspired oxygen tension and that in the arterial blood. Metaphorically, as the blindfolded anesthetist walks unknowingly towards the cliff of hypoxia—whether due to problems of inspired gas, equipment failure, underventilation, or abnormal pulmonary shunting—the protective hand of the pulse oximeter sentry stops him from falling over the edge. The oximeter will not tell him why he has been proceeding in that direction, or the direction back! On the other hand, should he start falling, the sentry functions on the vertical part of the dissociation curve and becomes an extremely

sensitive (if not always accurate) indicator of progress during the drop. Interestingly, it is highly probable that many fewer blood gas samples are being drawn during anesthesia now that pulse oximeters are so universally available. Our detailed insight into our patients' pulmonary oxygen exchange is less than with  $P_aO_2$  measurement but, because of the continuously available sentry, we believe our patients are safer. A prospective study to prove that important point with certainty may never be performed but, already, opinion seems overwhelmingly in favor of that belief.

Pulse oximetry has become a *de facto* standard for the American Society of Anesthesiologists (Eichhorn 1993). This means that, as alluded to in Fairley's description, although definitive statistical proof of the benefit of pulse oximetry may never be shown because of the rarity of complications due to anesthesiology in the operating theater, a large majority of those who use the device feel that it helps to reduce complications.

*2.2.4.2 Postoperative and critical care.* Pulse oximetry has proven very important to postoperative recovery because the patient's pulmonary control may still be compromised from the effects of anesthesia. For example, a randomized study by Lampe *et al.* (1990) found that of 141 patients having carotid endarterectomy 63% had episodes of  $S_pO_2$  less than 90% and 21% had episodes of  $S_pO_2$  less than 86% during the postoperative period. Similar studies also show large numbers of desaturation episodes, although variation in the data does exist (Severinghaus and Kelleher 1992).

The role of pulse oximetry in intensive and critical care units is similar to that for anesthesiology, although the patient's respiratory system may not be suppressed by narcotics and muscle relaxants. The instrument still acts as the sentry warning of desaturation from a variety of conditions, some of which were listed in table 2.2. In this setting, alarms and temporal records are very useful when constant surveillance of the patient is not possible.

*2.2.4.3 Exams and research studies.* The pulse oximeter is an excellent device for medical research studies such as sleep apnea and hypoxic ventilatory response (Severinghaus and Kelleher 1992). Medical exams such as stress tests also benefit from the noninvasive, continuous nature of pulse oximetry. In such cases,  $S_pO_2$  may be used to catch hypoxemic events and also correlated with other variables to glean information about the patient's general health.

### *2.2.5 Photoplethysmography*

Most pulse oximeters on the market feature a photoplethysmograph. The signal for the photoplethysmograph is derived from the same waveforms used to calculate  $S_pO_2$ . The photoplethysmograph may be used in a clinical setting in the same manner as a plethysmograph. However, the accuracy of the photoplethysmograph suffers from motion artifacts, and the patient must have adequate blood perfusion near placement of the pulse oximeter probe. Just as with the conventional plethysmogram, signal processing can derive heart rate from the photoplethysmogram waveform. Hence, most pulse oximeters also display heart rate. Similar to computing  $S_pO_2$ , temporal low-pass filtering abates the effect of motion artifacts on heart rate estimation.

2.2.6 Hyperoxia

Hyperoxia is the condition where blood in the system contains more than the normal amount of oxygen. Determining excessive levels of oxygen is important in many situations because of the toxic nature of oxygen radicals. Studies suggest that pulse oximetry is not useful for this type of application. For example, the role of  $S_aO_2$  for determining retinopathy of prematurity in neonates is not quite clear, and furthermore the 2 to 3% inaccuracy of  $S_pO_2$  for estimating  $S_aO_2$  adds to this uncertainty (Severinghaus and Kelleher 1992).

2.3 LIMITATIONS

2.3.1 Instrument and operation limitations

Many of the limitations to pulse oximetry will come to light throughout the remainder of this text. However, table 2.4 summarizes some limitations given by Severinghaus and Kelleher (1992). These are described in detail in the original source.

**Table 2.4** Limitations to pulse oximetry and its application in a clinical setting. Adapted from Severinghaus and Kelleher (1992).

Pulse oximetry limitations
Instrument incidence of failure
Low signal-to-noise ratio
Light shunting and poorly applied probe
Vasoconstrictors
Low-perfusion limits
Motion artifacts
Abnormal pulses
Ventilator-induced and venous pulse interference
Response times
Ambient light
Electrosurgery
Interference of MRI
Site selection for probe placement
Skin pigments, dyes, and nail polish
Dysfunctional hemoglobins
Burns and other dangers
False alarms and false nonalarms

2.3.2 Limitations in  $S_aO_2$

Often in anesthesiology medical literature, articles regarding a limitation of pulse oximetry appear in which, if read more closely, what is actually meant is a limitation in monitoring arterial oxygen saturation, e.g., Hutton and Clutton-Brock (1993), and Mak (1993). Authors of such articles point out this fact. It is interesting how measuring  $S_pO_2$  has become so associated with measuring  $S_aO_2$ .

Nonetheless, it follows that any limitations associated with  $S_aO_2$  as a monitored variable are also associated with  $S_pO_2$ .

There are some caveats to using  $S_aO_2$  to assess the condition of pulmonary function. It is difficult to regard any monitoring technique as foolproof, as there are usually misleading combinations of conditions that will result in the monitored variable appearing fine when, in fact, a potentially dangerous condition could exist for the patient. For example, Hutton and Clutton-Brock (1993) and Mak (1993) point out that pulse oximetry (i.e.,  $S_aO_2$ ) is a poor measure of hypoventilation when inspired oxygen concentration is high. It is in situations like this that a comprehensive approach to oxygenation assessment using other monitored variables is imperative.

## REFERENCES

- Ahrens T and Rutherford K 1993 *Essentials of Oxygenation* (Boston, MA: Jones and Bartlett)
- Bredle D L 1989 Circulatory compensation as a response to hypoxia *Clinical Aspects of O<sub>2</sub> Transport and Tissue Oxygenation* ed K Reinhart and K Eyrich (New York: Springer)
- Cherniack R M and Cherniack L 1983 *Respiration in Health and Disease* (Philadelphia, PA: Saunders)
- Des Jardins T R 1984 *Cardiopulmonary Anatomy & Physiology: Essentials for Respiratory Care* (Albany, NY: Delmar)
- Des Jardins T R 1990 *Clinical Manifestations of Respiratory Disease* (Chicago, IL: Year Book Medical)
- Eichhorn J H 1993 Pulse oximetry as a standard of practice in anesthesia *Anesthesiology* **78** 423–6
- Fairley H B 1989 Changing perspectives in monitoring oxygenation *Anesthesiology* **70** 2–4
- Hutton P and Clutton-Brock T 1993 The benefits and pitfalls of pulse oximetry *Brit. Med. J.* **307** 457–8
- Lampe G H, Wauk L Z, Whitendale P, Way W L, Kozmary S V, Donegan J H and Eger E I 1990 Postoperative hypoxemia after nonabdominal surgery: A frequent event not caused by nitrous oxide *Anesth. Analg.* **71** 597–601
- Mak V 1993 False reassurance of pulse oximetry *Brit. Med. J.* **307** 732–3
- Nunn J F 1987 *Applied Respiratory Physiology* (Boston, MA: Butterworths)
- Payne J P and Severinghaus J W (eds) 1985 *Pulse Oximetry* (New York: Springer)
- Selecky P A (ed) 1982 *Pulmonary Disease* (New York: Wiley)
- Severinghaus J W and Kelleher J F 1992 Recent developments in pulse oximetry *Anesthesiology* **76** 1018–38
- Tremper K K and Barker S J 1989 Pulse oximetry *Anesthesiology* **70** 98–108
- Vender J S 1992 *Mixed Venous Oximetry* (video recording) (Secaucus, NJ: Network for Continuing Education)

## INSTRUCTIONAL OBJECTIVES

- 2.1 State the fundamental question a clinician should ask when assessing the cardiopulmonary condition of a critically ill patient.
- 2.2 Give the normal values for  $S_aO_2$  and  $P_aO_2$  in the healthy adult.
- 2.3 State the difference between hypoxia, hypoxemia and hyperoxia.
- 2.4 Give several common problems that result in hypoxemia.
- 2.5 Describe the role of lactate as an indicator of improper oxygen transport.
- 2.6 Describe the role of  $S_pO_2$  as an indicator of improper oxygen transport.
- 2.7 List several physiologic variables that may be used in conjunction with  $S_aO_2$  for assessing a patient's cardiopulmonary condition.
- 2.8 Describe why pulse oximetry data are of importance to anesthesiology.
- 2.9 State how useful pulse oximetry is in detecting hyperoxia.
- 2.10 List several limitations to pulse oximetry.

## CHAPTER 3

---

# BLOOD OXYGEN MEASUREMENT

*James Farmer*

Oximetry is a general term that refers to the optical measurement of oxyhemoglobin saturation in the blood (Peterson 1986). Pulse oximetry is only one of those technologies. There are other methods of measuring oxygen content of the blood as well. Gradwohl (1948) describes two colorimetric methods of estimating the  $HbO_2$  of the blood by direct comparison to a color chart. The Dare method used a thin layer of undiluted blood which was matched against a standard series of colored disks. The Tallqvist method used a drop of undiluted blood placed on absorbent paper. The absorbent paper was compared with a graded scale of colored blocks printed on paper. The Tallqvist method was reported to be inaccurate and not recommended. No information on the reliability of the Dare method was given.

This chapter describes several different chemical and optical methods of determining the oxygen saturation of the blood which are more deterministic than the ones above. The chapter examines the development of oximetry from a historical perspective. The final section of the chapter gives an overview of the design of a pulse oximeter.

Some of the methods described in this chapter find the partial pressure of oxygen ( $PO_2$ ) and some find the oxygen saturation ( $SO_2$ ). Chapter 1 describes the relationship between these two. It is interesting to note from a historical perspective that  $SO_2$  was not always an accepted means of reporting blood oxygenation. Gradwohl (1948) stated, 'Hemoglobin estimations are reported in terms of percentage, but this incorrect. They should always be reported in terms of grams per 100 mL.'

### 3.1 CHEMICAL METHODS

The oxygen content of blood can be determined from a sample by using chemical reactions to remove the oxygen from the blood. These measurements can be done with varying degrees of success. The chemical reactions can be slow also. The Van Slyke method can take up to 20 min.

### 3.1.1 Van Slyke method

The Van Slyke apparatus (figure 3.1) is used in a method of measuring the oxygen content of a blood sample. A sample of blood is introduced to the apparatus anaerobically with a sample of potassium ferricyanide. Potassium ferricyanide is a releasing agent that releases the oxygen, carbon dioxide, and other gases from the blood sample. After removing the carbon dioxide from the mixture, the remaining gases are compressed into a fixed volume and the resulting pressure ( $P_1$ ) is measured from the manometer. The oxygen is then absorbed with a reagent such as sodium hydrosulfite. The remaining gases are then recompressed into the same fixed volume and the final pressure ( $P_2$ ) is measured (Hill 1966).

The difference of the two pressure measurements is a partial pressure due to the oxygen that was contained in the blood sample. The oxygen content of the blood sample is calculated by

$$\text{mL O}_2/100 \text{ mL blood} = K(P_1 - P_2) \quad (3.1)$$

where  $K$  is a constant relating to the reagents, apparatus, and the volume of the blood sample (Adams and Hahn 1982). Alternatively, the oxygen can be extracted from the blood with the Van Slyke apparatus and analyzed with a gas chromatograph (Hill 1966).

The technique is not simple to perform. Technical expertise and experience with chemical reactions are required to obtain accurate, reproducible results. However, the Van Slyke apparatus can provide measurements accurate to  $\pm 0.03\%$  (Adams and Hahn 1982). The Van Slyke technique has been in the past a standard by which blood oxygen measurements were made (Miller 1966, Dennis and Valeri 1980).

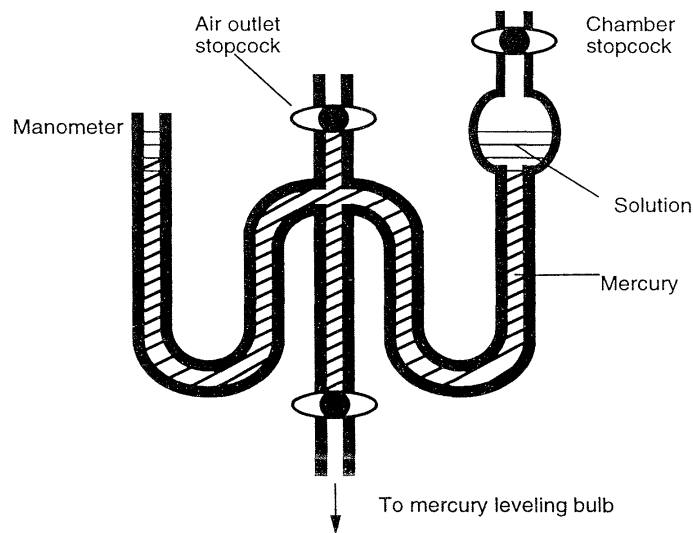

**Figure 3.1** The Van Slyke apparatus (adapted from Adams and Hahn 1982).

### 3.1.2 Mixing syringe method

The mixing syringe method also measures the amount of oxygen released from a blood sample by a chemical reagent. The apparatus consists of two Luer-lock syringes joined to a manometer tap. One of the syringes is a precision automatic syringe which is able to accept and deliver a fixed volume of reagent. The automatic syringe is filled with the oxygen releasing agent and then emptied. This coats the inside of the syringe with the reagent and keeps the blood from any contact with the air. The oxygen releasing agent has a known oxygen partial pressure ( $P_r$ ). The automatic syringe then draws a volume of blood ( $V_b$ ) from the mixing syringe. The volume of blood and a known volume of the reagent ( $V_r$ ) are mixed back and forth between the syringes. The partial pressure of oxygen of the blood–reagent solution ( $P_s$ ) is then measured by a blood-gas analyzer. The oxygen content is calculated from the equation

$$\text{mL O}_2/100 \text{ mL blood} = \alpha \frac{V_r + V_b}{V_b} \left[ P_s - \left( \frac{V_r}{V_r + V_b} P_r \right) \right] \quad (3.2)$$

where  $\alpha$  is the solubility coefficient of oxygen in the blood–reagent solution at the temperature at which the measurement was made. Its value is obtained from either a separate experiment or from reference tables (Adams and Hahn 1982).

### 3.1.3 The Clark electrode

The Clark electrode uses the basic chemistry principles of oxidation and reduction to measure the  $PO_2$  (partial pressure of oxygen) in a solution. When oxygen is dissolved in an aqueous solution and exposed to a 0.7 V polarizing voltage, the following reaction occurs

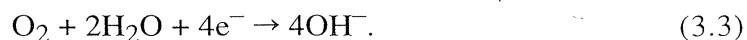

A silver anode immersed in a potassium chloride electrolyte bath will attract anions ( $\text{Cl}^-$ ) to form silver chloride. This oxidation reaction produces a constant flow of electrons. A nearby platinum electrode undergoes a reduction reaction turning oxygen to hydroxyl ions ( $\text{OH}^-$ ) as in equation (3.3). Figure 3.2 shows that the number of electrons used in the platinum cathode reaction is directly proportional to the  $PO_2$  present in the bath. Therefore, by measuring the current between the two electrodes, the  $PO_2$  in the solution is determined.

The entire Clark electrode system (figure 3.3) has a polypropylene sheath which slows the diffusion of oxygen from the blood to the electrode. This prevents the electrode from depleting the  $PO_2$  in a particular place and eliminates the need to stir the blood *in vitro*.

The Clark electrode is the common sensing device used by blood gas analyzers to determine the  $PO_2$  of the blood (Shapiro *et al* 1989). Using a variety of different electrodes, blood gas analyzers also determine the pH and  $PCO_2$  of blood samples as small as 65  $\mu\text{L}$ . The blood gas analyzers are very useful for *in vitro* measurements because they self-calibrate and self-diagnose malfunctions. Thus, interfacing blood gas analyzers with computers allows for automated measurements, patient data storage, and billing.



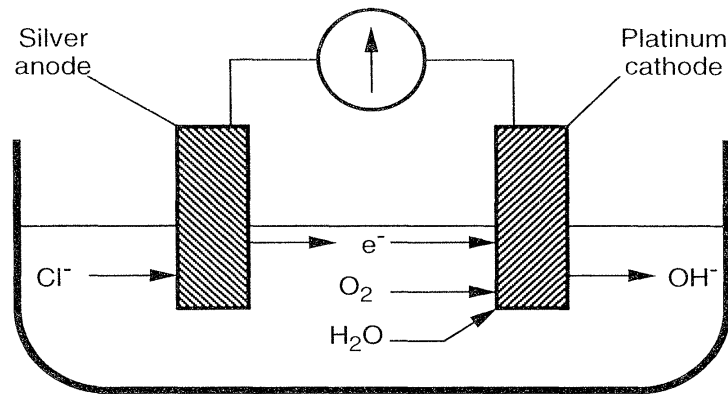

**Figure 3.2** Since an aqueous solution has plenty of  $\text{H}_2\text{O}$  and the silver anode is able to supply an abundance of electrons, equation (3.3) is limited by the amount of oxygen present. Thus, the amount of current between the anode and the cathode is determined by the  $\text{PO}_2$  present. This reaction shows the chemical reaction that occurs in a Clark electrode.

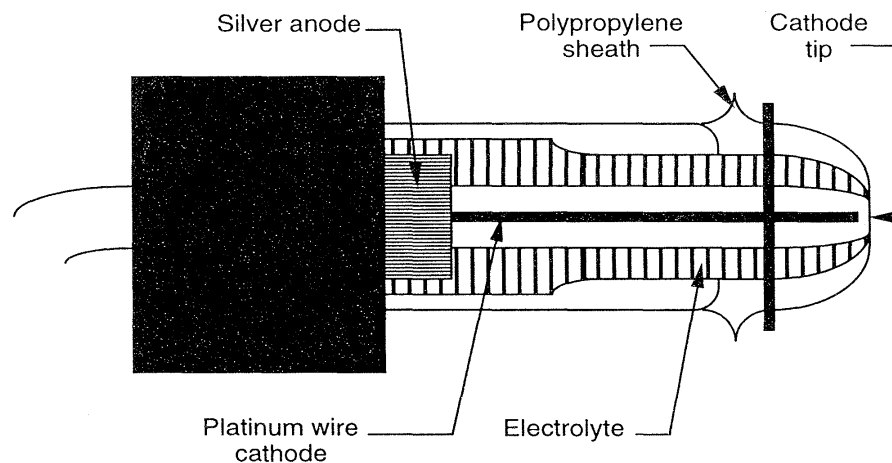

**Figure 3.3** A Clark electrode (adapted from Shapiro *et al* 1989).

The Clark electrode can also be used to make *in vivo* measurements when designed to be used as catheter electrodes (Adams and Hahn 1982). Many catheter electrodes are designed specifically to be used with infants and are very small in diameter. Several different versions exist. Some versions have both the anode and cathode within the single electrode, as pictured in figure 3.3. But others have an external anode reference electrode on the skin.

One of the downfalls of the Clark electrode catheter system is calibration. Calibration takes place by drawing a blood sample near the end of the catheter and analyzing the sample with an *in vitro* blood gas analyzer. Another potential problem with the Clark electrode is keeping the tip clean. Though the polypropylene sheath helps to some extent, failure to keep the catheter in the flow of blood can cause errors as blood coagulates on the surface of the electrode.

### 3.1.4 The galvanic electrode

The galvanic electrode is similar in operation to the Clark electrode. As oxygen passes across the electrode, a chemical reaction occurs that produces a small electric current. But in this case the cathode is made of gold, the anode of lead, and the electrolyte solution is potassium hydroxide. In the Clark electrode, the silver anode and the platinum cathode participated in the chemical reaction. This made sure that the electrolyte solution was always replenished. But, the galvanic electrode has no means to replenish the electrolyte solution in the electrode and so it has a limited lifetime which depends on the  $PO_2$  and exposure (Shapiro et al 1982).

## 3.2 TRANSCUTANEOUS $PO_2$ SENSOR

The Clark electrode can be used noninvasively to determine  $PO_2$  of the blood. Under normal conditions, the  $PO_2$  of the blood near the skin's surface ( $P_{tc}O_2$ , for the transcutaneous partial pressure of oxygen) is atmospheric. But, hyperemia of the skin can cause the  $P_{tc}O_2$  to approach  $P_aO_2$ , the arterial partial pressure. Hyperemia of the skin can be induced by drugs, creams, abrasions, or heating the skin. In other words, by placing a Clark electrode on the skin with a heating element, the skin begins to diffuse oxygen so that the  $P_{tc}O_2$  is nearly equal to the  $P_aO_2$ . The measurements given by the transcutaneous  $PO_2$  electrode are stable with little drift and are widely accepted (Gothgen and Jacobsen 1987).

Heating is the easiest method of inducing hyperemia to control. With a heating element and a thermistor, the skin is heated to between 43 °C and 44 °C. This is the optimal temperature range for the  $P_{tc}O_2$  to approach the  $P_aO_2$  with minimal skin damage. The heat causes increased blood flow to the skin at the heating element site. This increased perfusion causes more  $O_2$  to be delivered to this area and the excess  $O_2$  diffuses through the skin more easily (Peura 1998). Figure 3.4 shows a cross sectional view of a transcutaneous  $PO_2$  electrode, showing the heater and the thermistor.

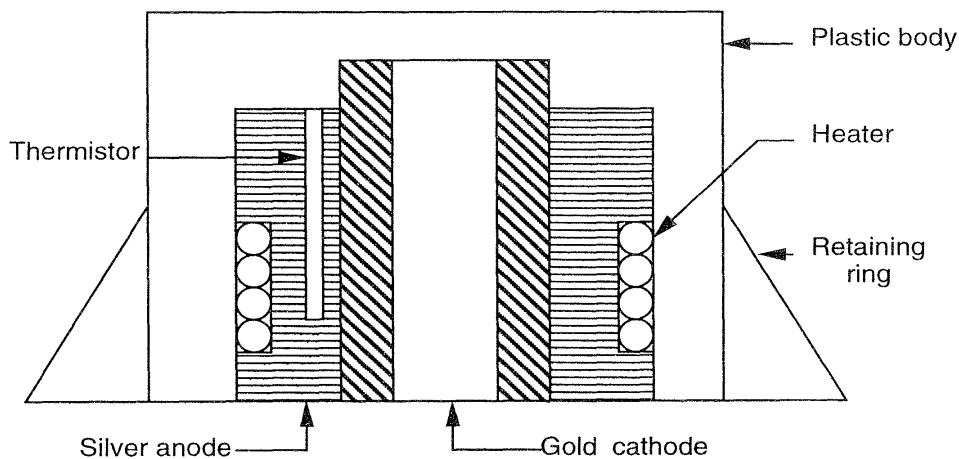

**Figure 3.4** A cross section of a transcutaneous  $PO_2$  electrode. The electrolyte below the anode and cathode is held in place by a polypropylene membrane.

One advantage of the transcutaneous  $PO_2$  electrode is that it measures the *real*  $P_{tc}O_2$  and is not an empirical calculation as with the pulse oximeter (Gothgen and Jacobsen 1987).  $P_{tc}O_2$  can be thought of as a new  $PO_2$  variable and not an estimation of  $P_aO_2$ . This contrasts with the pulse oximeter, which is an estimate of  $S_aO_2$ , and whose accuracy is dependent on its ability to predict  $S_aO_2$  (Barker and Tremper 1984). But again, one of the disadvantages of the transcutaneous  $PO_2$  sensor is the calibration. Like the Clark electrodes used with catheters and blood gas analyzers, the transcutaneous  $PO_2$  measurement is based on an electrochemical reaction that needs to be calibrated frequently with some gas mixtures.

The transcutaneous  $PO_2$  electrode has other disadvantages. There is a warm up time of 10 min for the heating element to induce enough blood flow to the measurement site. And even with the thermistor regulating the heating element, there is a risk of burns, especially in infants. It is recommended that the electrode be moved every 4 hours (Burtis and Ashwood 1994).

The  $P_{tc}O_2$  does not vary more than 5% from the  $P_aO_2$  in infants but is more dependent on blood flow in adults. The heating is not as effective in adults and so the  $P_{tc}O_2$  is usually lower than the  $P_aO_2$  (Barker and Tremper 1984). Also, transcutaneous  $PO_2$  electrodes are unreliable when the blood pressure falls below 100 mmHg or when some anesthetics such as nitrous oxide are administered (Burtis and Ashwood 1994). Even with these problems, the transcutaneous  $PO_2$  electrode has been found useful in clinical situations in the operating room, intensive care units, and emergency rooms (Waxman *et al* 1983).

### 3.3 *IN VITRO* OXIMETERS

#### 3.3.1 *Spectrophotometers*

Spectrophotometry is the basis for all oximetry. The atoms of all molecules vibrate in specific patterns for each unique substance. As light passes through a substance, the frequencies of light similar to the vibrational frequencies of the substance are absorbed. A spectrophotometer measures the intensity of light transmitted through a particular substance at particular wavelengths. The fraction of light absorbed at a specific wavelength is determined by the absorptivity, or extinction coefficient, of the substance. The extinction coefficient of a substance can be graphed at various wavelengths as a spectrum. This spectrum is unique for every substance.

A photodetector is a device that converts light intensity into an electric current. A given intensity of light transmitted through a substance produces an electric current proportional to the intensity. By measuring the intensity of incident light on a substance ( $I_0$ ) and measuring the intensity of light transmitted through the substance ( $I$ ), the transmittance ( $T$ ) of the substance can be calculated:

$$T = \frac{I}{I_0}. \quad (3.4)$$

Because each molecule absorbs an equal portion of light, the absorbance of light through a substance is linearly related to the concentration of substance

present. From the measured transmittance ( $T$ ), the absorbance ( $A$ ) can be calculated from

$$A = 2 - \log (\%T). \quad (3.5)$$

Beer's law can now be used to find the amount of substance in a solution. Beer's law can be stated as

$$A = \varepsilon(\lambda) c d \quad (3.6)$$

where  $\varepsilon(\lambda)$  is the extinction coefficient of the substance at a given wavelength  $\lambda$  of light,  $d$  is the length of the light path, and  $c$  is the concentration of the substance. For all substances, the linear relationship between absorbance and concentration only holds up to a certain concentration. Below this limit we can determine a calibration constant. The calibration constant can then be used as a standard to determine the unknown concentration of a substance with the same extinction coefficient as the standard.

For a solution with two unknown compounds, the absorbances at two wavelengths can be used to calculate the concentrations of both compounds. At the isosbestic point where the two extinction coefficients are equal, Beer's Law for the two samples can be written as

$$d = \frac{A_{ec}}{[c_1 + c_2]\varepsilon(\lambda_{ec})} \quad (3.7)$$

where  $A_{ec}$  is the absorbance at the isosbestic point and  $\varepsilon(\lambda_{ec})$  is the extinction coefficient of the two substances at the isosbestic point. At the second wavelength Beer's Law gives

$$A_0 = d[c_1\varepsilon_1(\lambda_0) + c_2\varepsilon_2(\lambda_0)] \quad (3.8)$$

where  $A_0$  is the absorbance and  $\varepsilon_1(\lambda_0)$  and  $\varepsilon_2(\lambda_0)$  are the extinction coefficients for the two compounds at the second wavelength. Because the sum of the concentrations of the two compounds is 1, we can solve equations (3.7) and (3.8) for the two concentrations.

If the solution contains more than just the two compounds as is the case with oximetry, solving equations (3.7) and (3.8) will give the relative concentration of  $c_1$  to  $c_2$  if the assumption can be made that none of the other compounds will absorb light at the two wavelengths used for the measurement. This assumption is sufficient for oximetry where the relative concentrations of Hb and HbO<sub>2</sub> are used to estimate  $S_aO_2$ .

Note that measuring the absorbance at the isosbestic point is not necessary to solve for  $c_1$  and  $c_2$ . The absorbance at any two wavelengths can be used to solve for the concentrations with equally good results. The motives for the choice of the isosbestic point as one of the wavelengths used in the earliest oximeters are not clear. But the simplified mathematics may have been a reason (Nilsson 1960).

With the concentrations of Hb and HbO<sub>2</sub>, an estimation of  $S_aO_2$  is made from

$$S_p O_2 = \frac{HbO_2}{HbO_2 + Hb} \times 100\% \quad (3.9)$$

This assumes that any other substance present in the solution being measured has no effect on the absorbance of light at the chosen wavelengths. For example, it does not take into account the effect of the other types of hemoglobin present in the blood. These hemoglobin species do absorb light at certain wavelengths, but their relative concentration with respect to Hb and HbO<sub>2</sub> is small enough that for many applications equation (3.9) is an accurate estimate.

### 3.3.2 The CO-oximeter

CO-oximeters are spectrophotometers specifically designed to analyze the concentrations of several different types of hemoglobin including reduced hemoglobin (Hb), oxyhemoglobin (HbO<sub>2</sub>), carboxyhemoglobin (COHb), and methemoglobin (MetHb). Each of these various forms of hemoglobin has its own extinction coefficient curve (figure 4.2). By using as few as four wavelengths of light, the amount of each of these forms of hemoglobin can be determined from a sample.

Instrumentation Laboratories Inc. coined, but did not copyright, the term CO-oximeter and released the first commercial CO-oximeter in 1966 (Moyle 1994). The CO-oximeter was originally introduced to measure COHb using three different wavelengths, 548 nm, 568 nm and 578 nm (Adams and Hahn 1982). The IL-282 CO-oximeter pictured in figure 3.5 uses four wavelengths of light, 535.0 nm, 585.2 nm, 594.5 nm, and 626.6 nm, to measure all four of the relevant forms of hemoglobin. These wavelengths are obtained by four interference filters mounted on a rotating wheel each selecting wavelengths of light from a Ti-Ne hollow cathode lamp (Zwart *et al* 1981). The CO-oximeter is able to operate in this narrow range of light because it only works with diluted plasma samples and like pulse oximeters does not have to deal with skin, muscle, or other tissue (Moyle 1994).

A four wavelength CO-oximeter would obtain absorbance readings on a blank solution at all four different wavelengths ( $\lambda_{1-4}$ ). Then a reading is obtained at each wavelength for a diluted, hemolyzed sample. CO-oximeters use hemolyzed samples, blood samples with the red blood cell membranes removed, to reduce the amount of light scattering, which reduces the accuracy of the measurement.

The absorbance readings of the blank solution are subtracted from the readings from the samples at each wavelength to give the absorbance of the blood at each wavelength. From these absorbances of the blood, the concentration of each type of hemoglobin can be calculated from the equations

$$C_{Hb} = K[\epsilon_{Hb}(\lambda_1)A_1 + \epsilon_{Hb}(\lambda_2)A_2 + \epsilon_{Hb}(\lambda_3)A_3 + \epsilon_{Hb}(\lambda_4)A_4] \quad (3.10)$$

$$C_{HbO_2} = K[\epsilon_{HbO_2}(\lambda_1)A_1 + \epsilon_{HbO_2}(\lambda_2)A_2 + \epsilon_{HbO_2}(\lambda_3)A_3 + \epsilon_{HbO_2}(\lambda_4)A_4] \quad (3.11)$$

$$C_{MetHb} = K[\epsilon_{MetHb}(\lambda_1)A_1 + \epsilon_{MetHb}(\lambda_2)A_2 + \epsilon_{MetHb}(\lambda_3)A_3 + \epsilon_{MetHb}(\lambda_4)A_4] \quad (3.12)$$

$$C_{COHb} = K[\epsilon_{COHb}(\lambda_1)A_1 + \epsilon_{COHb}(\lambda_2)A_2 + \epsilon_{COHb}(\lambda_3)A_3 + \epsilon_{COHb}(\lambda_4)A_4] \quad (3.13)$$

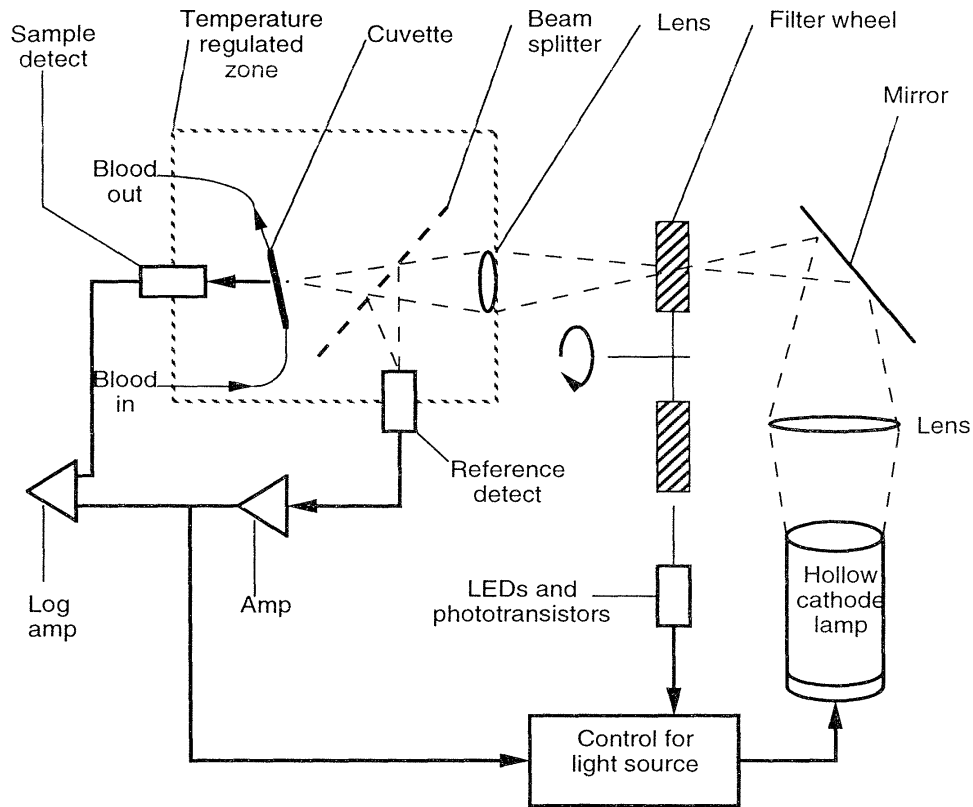

Figure 3.5 A schematic diagram of the IL-282 CO-oximeter (adapted from Zwart *et al* 1981).

where  $C_x$  is the concentration of hemoglobin type  $x$ ,  $\epsilon_x(\lambda_1)$  is the extinction coefficient of hemoglobin type  $x$  at the first wavelength,  $A_1$  is the difference between the absorbance value of the blood and the blank solution at the first wavelength, and  $K$  is a constant set by the calibration procedure (Shapiro *et al* 1989).

CO-oximeters are subject to many sources of error. Any substances in the sample that scatter light affect the measurements because the amount of light transmitted is no longer solely a function of the light absorbed by hemoglobin species. Samples infected with small portions of lipids or cell fragments are common causes of light scattering. There are also errors associated with fetal hemoglobin samples. Results from CO-oximeters have been known to give falsely high COHb readings in fetal hemoglobin (Zwart *et al* 1981). Some CO-oximeters try to compensate for these errors by using more wavelengths of light. For example the AVL 912 uses 17 wavelengths to try to compensate for other light absorbing fragments that might be present in the solution (Moyle 1994).

Because CO-oximeters make measurements *in vitro* with discrete samples, they provide accurate oxygen saturation readings for only the times at which the samples are drawn. They do have their uses, notably as a standard for calibration of *in vivo* oximeters (Moyle 1994). The CO-oximeter is one of the most accurate methods available for measuring the four clinically relevant hemoglobin species. It is a standard against which other methods of measurement are compared (Shapiro *et al* 1989).

### 3.4 *IN VIVO* TWO-WAVELENGTH OXIMETERS

#### 3.4.1 *The first in vivo oximeters*

*In vivo* oximetry originated in Germany in the 1930s when the use of the selenium photovoltaic cell became accepted (Peterson 1986). In 1934, Kramer showed that the absorbance of red light depended on oxygen saturation, but his implementation only used one wavelength of light (Payne and Severinghaus 1986). At about the same time, Matthes designed an oximeter which measured the transmission of light through the ear by a lamp with a photocell attached to the earlobe. At the time, regions of optical spectra were broadly defined and depended greatly on the lamp, photocell, and filters used. Matthes used wavelengths of red light, which varied the transmission measurements as the oxygen saturation varied, and compared them to measurements using green light, which did not vary with saturation. He later discovered that infrared light was a better choice than green (Nilsson 1960).

Glen Millikan is credited with coining the term oximeter while, during World War II, attempting to design a hemoglobin saturation meter for the ears of pilots to control the amount of oxygen they received (Severinghaus 1987). Millikan's ear piece was improved by Wood and Geraci in 1949. The biggest improvement was in the infrared filter. They also had the idea of using an inflatable balloon to cut off the circulation to the ear and make it bloodless. This made for a zero setting which tried to account for the other tissue present in the ear. Wood thought he had succeeded in the first absolute reading oximeter but he later showed that inconsistencies in the photocells used for light detection caused the device to be inaccurate (Payne and Severinghaus 1986).

#### 3.4.2 *The Cyclops*

The Cyclops was a commercially available reflectance oximeter. It was named the Cyclops because of the large sensing device that was placed on the forehead of the patient. It used red and green light to determine  $SO_2$ . Limitations in the technology of photocells limited the Cyclops from using infrared light. The theory of the device was based on the fact that any reflection of the green light was due to nonblood reflection. The reflection of the red light was due to both the blood and noncomponents. So, by subtracting the green light reflection from the red light reflection, the reflection due to the blood was found.

The Cyclops was successful in producing trending information about  $SO_2$ . And if it was calibrated against two or more arterial blood samples, the Cyclops could produce accurate  $SO_2$  values (Zijlstra 1958).

### 3.5 FIBER OPTIC OXIMETERS

#### 3.5.1 *In vitro reflectance oximeter*

Polanyi and Hehir (1962) first described the design of a fiber optic oximeter to use as a catheter measurement device. They also used two wavelengths of light to measure the concentrations of Hb and HbO<sub>2</sub>. They chose the specific values for

their wavelengths of light to be 660 nm and 805 nm; 805 nm is the isosbestic point of HbO<sub>2</sub> and Hb. They used a filter wheel, similar to the one used in the CO-oximeter in figure 3.5, to obtain their wavelengths.

The concentrations of Hb and HbO<sub>2</sub> can be calculated in the same manner as in section 3.3.1. The only difference with this device is that this fiber optic oximeter was a reflectance device and measured an absorbance directly from the backscattered light in the blood. In Section 3.3.1, the measurement was a transmittance of light which was converted to an absorbance.

Polanyi and Hehir presented successful results with their fiber optic oximeter with *in vitro* experiments. But although they intended their device to be used *in vivo*, it did not come to be (Barker 1991).

### 3.5.2 *In vivo* reflectance catheter oximeter

*In vivo* catheter oximeters were not in widespread use until about 1980. These *in vivo* fiber optic catheter oximeters use much the same technology as the pulse oximeter. Many catheter oximeters are two-wavelength devices like the pulse oximeter. Some of them use three wavelengths to try to compensate for changes in pH or other variables. Figure 3.6 shows the basic configuration of a fiber optic reflectance oximeter.

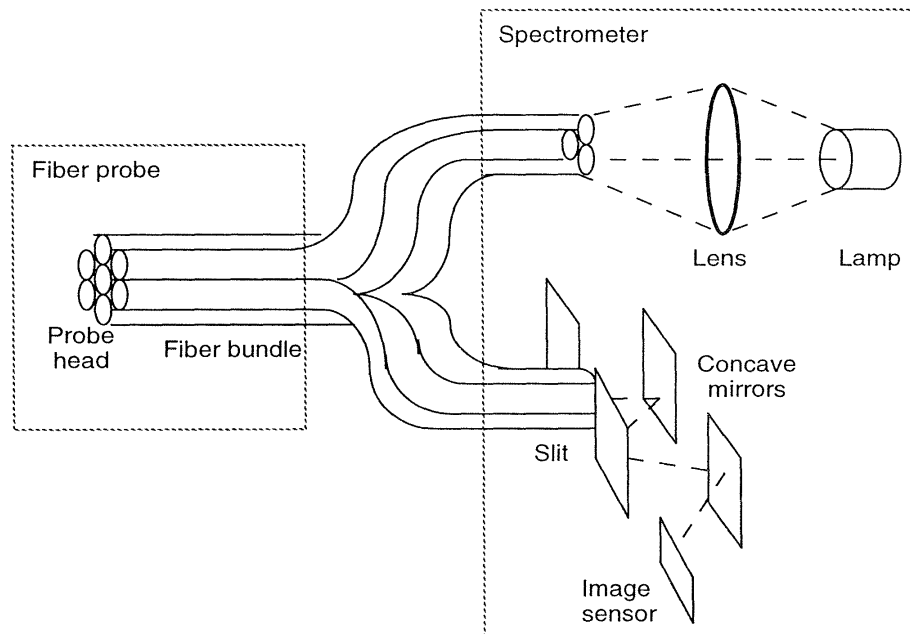

**Figure 3.6** A fiber optic reflectance catheter oximeter (adapted from Ono *et al* 1991).

These devices do require user calibration though. The calibration can be done with a CO-oximeter or by the preferred method of *in vivo* calibration. Drift can occur after several hours and the catheter may need to be recalibrated.

Some of the early fiber optic catheters had the problem of wall artifacts, where reflections of light from a vessel wall would cause erroneous values of  $S_{vO_2}$ . New digital filtering techniques have helped to reduce that problem. Early



catheters had a reputation for being stiff and hard to insert, but the use of plastic fiber optics has helped this issue (Barker 1991).

The early fiber optic oximeters were designed for cardiac catheterization to measure  $S_vO_2$ . Features have been added to some fiber optic probes for other uses. For example, some probes have a contact sensor or a pressure sensor to sense contact with tissue. This allows more stable data from *in vivo* tissue because the probe head can avoid excessive pressure which would affect microcirculation. Another application for the fiber optic oximeter is as a dental tool to diagnose  $SO_2$  of gingiva (Ono *et al* 1991).

### 3.5.3 *In vivo* chemical oximeter

Peterson and Fitzgerald (1984) describe a chemical fiber optic oximeter suitable for measuring  $P_aO_2$ . A fluorescent dye in the tip of the probe reflects light sent by the oximeter back to a sensor. The dye has a unique property that it loses its luminescence in the presence of oxygen. Figure 3.7 shows the chemical fiber optic probe. The difference between this probe and the reflectance fiber optic probe is a small one. The reflectance fiber optic probe measures the change in color of the blood by reflecting light from it. This change in color indicates the degree of saturation. This device measures the change in color of a substance that changes color in the presence of oxygen.

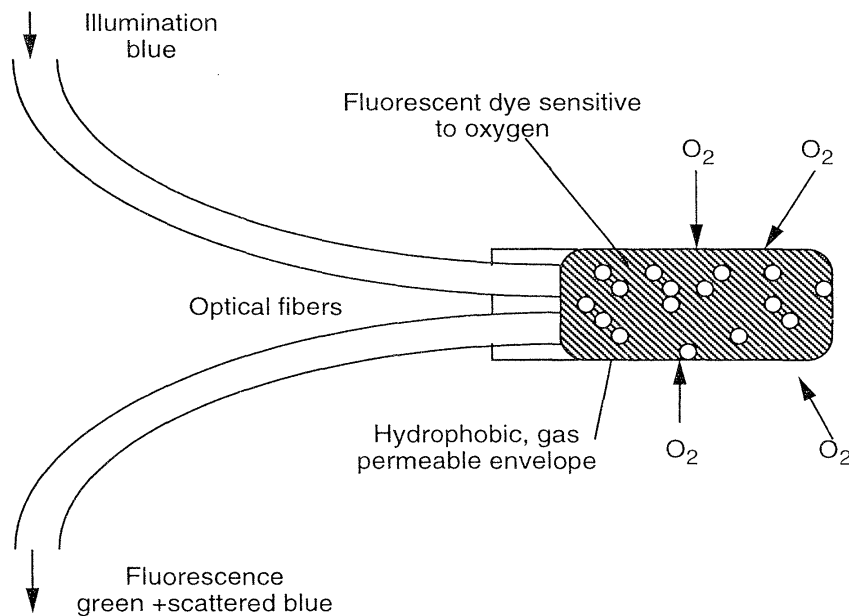

**Figure 3.7** This figure shows the probe end of a chemical fiber optic oximeter. The coloration of the probe end changes in response to the amount of oxygen present.

## 3.6 *IN VIVO* EIGHT-WAVELENGTH OXIMETER

In 1970, Hewlett-Packard marketed an eight-wavelength oximeter, model 47201A. The device was designed to overcome some of the problems of the two-wavelength oximeter. It was designed to be self calibrating, accounted for factors

like skin pigmentation, and claimed to be unaffected by motion (Merrick and Hayes 1976). The device also claimed to be precalibrated requiring no test samples. The only calibration necessary was an infrequent procedure that gave reference values of light intensity to the device, and did not involve the patient.

Figure 3.8 shows a block diagram of the 47201A. The lamp is a tungsten-iodine lamp which has a high output of light in the wavelengths of interest (650 nm to 1050 nm). The desired wavelengths are obtained with light filters. The filters are mounted on a rotating wheel so they cut the light beam sequentially. The wheel spins at 1300 rpm so about 20 samples at each wavelength are obtained every second.

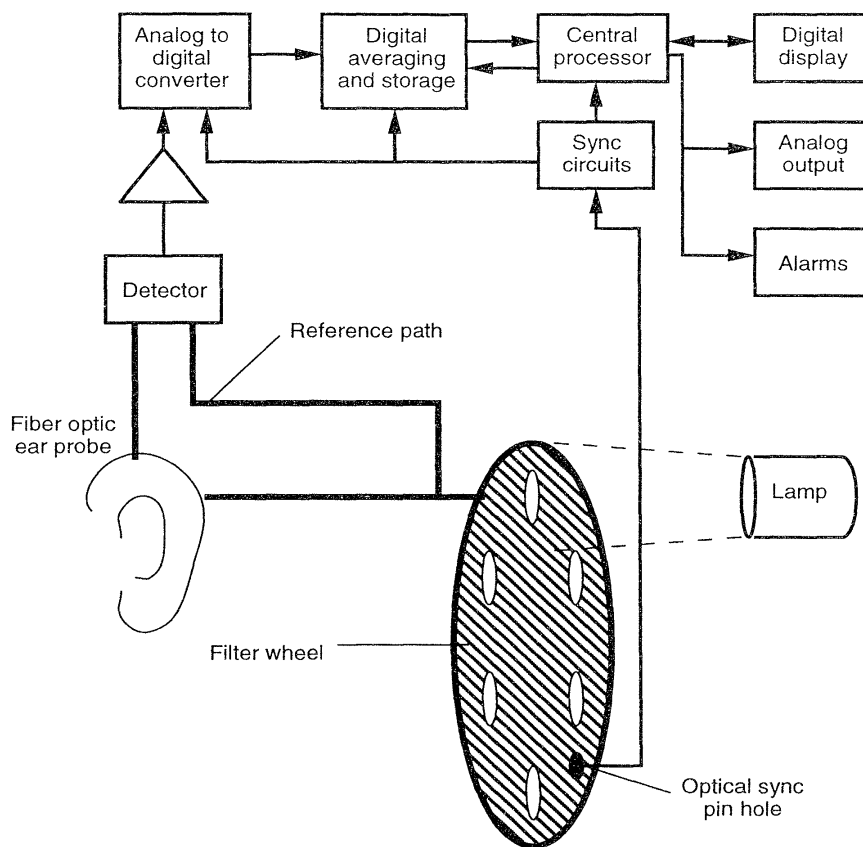

Figure 3.8 Block diagram of the Hewlett-Packard Model 47201A eight-wavelength ear oximeter.

The filtered light travels down two fiber optic paths. The first path leads directly to the photodetector and acts as a reference. This prevents any variations in the measurements due to changes in the light source or slight variations in the filters. The second fiber optic path goes to the ear probe. The filtered light is transmitted through the ear to a fiber optic cable which carries it to the photodetector. The current produced by the photodetector may be on the order of 0.5 nA so the output of the photodetector is amplified by a factor of  $10^8$ . The absorbance is derived from the difference between the reference intensity and the intensity of the light transmitted through the ear.

For a time, the Hewlett-Packard device was the gold standard for oximeters. It worked fairly well and was the first introduction of noninvasive oximetry into

a clinical environment. But it was found to be inaccurate for saturations less than 70%. And though it was a large improvement over previous devices, the Hewlett-Packard device was not totally immune to motion artifacts or skin pigmentation as it claimed. Also, it still required that the probe heat the skin. Devices that heat the skin put the patient at risk of burns, especially infants who have sensitive skin.

Although giving an improvement in performance, the device was huge, weighing almost 17 kg. The ear probe was also quite large and the fiber optics were fragile. Though it was the *gold standard* of oximeters in its time (Moyle 1994) it was used clinically only in sleep studies, pulmonary medicine, and physiology. The HP eight-wavelength oximeter was never used in anesthesiology or critical care as the pulse oximeter is today. Its use declined even more with improvements in the Clark transcutaneous  $PO_2$  electrode (Severinghaus 1987).

### 3.7 PULSE OXIMETERS

The idea of exploiting the pulsatile nature of arterial blood in oximetry first belonged to Takuo Aoyagi while working in Japan for Nihon Kohden Corporation (Severinghaus 1987). Nihon Kohden's device used analog circuitry, had bulky fiber optic cables, and still had some of the instability problems of the Hewlett-Packard device. Other companies such as Minolta came up with similar products with similar problems (Santamaria and Williams 1994).

An anesthesiologist named William New saw the pulse oximeter marketed by Minolta and saw how to improve it. New, also an electrical engineer, teamed with Jack Lloyd to found Nellcor, Inc. Nellcor produced a microprocessor-based pulse oximeter, the N100, which was smaller, less expensive, needed no user calibration, and was accurate enough for clinical use. Nellcor is still the market leader in pulse oximetry (Santamaria and Williams, 1994). About the same time, Ohmeda came up with a similar device, the Biox II, which had similar success (Wukitsch *et al* 1988). Today, pulse oximeters exist in every intensive care unit, surgical suite, and in many emergency rooms in the United States (Santamaria and Williams 1994)

This section gives a brief description of the major parts of a pulse oximeter. Further detail of each of these parts can be found in later chapters.

#### 3.7.1 Overview

By taking advantage of the pulsatile flow of blood, the pulse oximeter is able to overcome many of the problems of earlier technologies. The pulse oximeter tracks the change in light absorbance as the blood pulses. By tracking this peak-to-peak ac component, the absorbance due to venous blood or tissue does not have any effect on the measurement.

Light scattering is still a source of inaccuracy in pulse oximeters. Beer's law does not account for the scattering of light. So a direct calculation of  $S_aO_2$  is not possible. The pulse oximeter measures absorbances at the two wavelengths and uses data from CO-oximeters to empirically look up a value for  $S_pO_2$ , an estimation of  $S_aO_2$ .

## 3.7.2 LEDs

One of the large improvements of the pulse oximeter over earlier oximeters is the use of LEDs as the light source. The LEDs can transmit large intensities of light proportional to the amount of drive current. The LED control block in figure 3.9 controls the amount of drive current and the timing of the LEDs. The timing of the pulsations is critical because the photodiode cannot distinguish between different wavelengths of light. The pulse oximeter relies on the microprocessor system to synchronize the pulsations of the LEDs with the samples taken by the ADC so that the absorbances detected by the photodiode can be attributed to the correct LED.

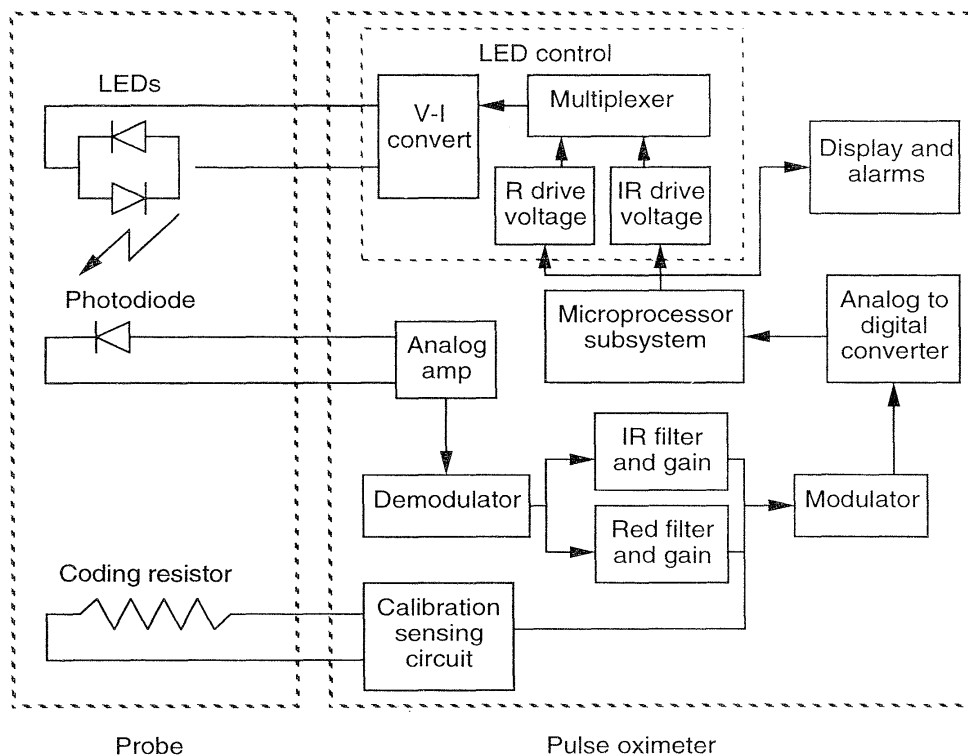

**Figure 3.9** Block diagram of a pulse oximeter system. The arrows show the flow of data. The microprocessor also provides control and timing for the demodulator, modulator, and LED control circuits.

The two wavelengths chosen for pulse oximetry are 660 nm and 940 nm. These wavelengths were chosen based on the availability of LEDs at these wavelengths and because the extinction coefficients of Hb and HbO<sub>2</sub> vary as much as possible. HbO<sub>2</sub> has a higher extinction coefficient than Hb at 940 nm and a lower extinction coefficient at 660 nm. In other words, as  $S_aO_2$  increases, the absorbance of light increases at 940 nm and decreases at 660 nm.

One disadvantage of using LEDs as a light source is that the exact wavelength of any single LED can vary by as much as  $\pm 15$  nm. This would cause significant errors if unaccounted for. To account for this, some manufacturers characterize each LED and code it with a resistor value. By driving the coding resistor (figure 3.9) with a constant current source, the pulse oximeter can

measure the voltage and take the characterization of the LEDs into account when empirically calculating  $S_pO_2$  (Pologe 1987).

### 3.7.3 Photodiode

The photodetector is a silicon photodiode that produces current linearly proportional to the intensity of light striking it. Advances in silicon technology allow the photodiode to be small enough to fit in small, finger tip probes. These advances have helped make the pulse oximeter much more accurate and convenient than earlier devices. Early oximeter devices needed frequent calibration because the photoelectric devices used as sensors were often inconsistent (Miller 1966).

A photodiode cannot distinguish between red and infrared light, but to accommodate this, the microprocessor system alternately turns each LED on and off. The pulse oximeter repeatedly samples the photodiode output while the red LED is on, while the infrared LED is on, and while both are off. By sampling with both LEDs off, the pulse oximeter is able to subtract any ambient light that may be present (Pologe 1987).

### 3.7.4 Probes

Improved technology in photodiodes and LEDs has another benefit. They allow the probe to be small and attach to the pulse oximeter with conventional wires. The Hewlett-Packard eight wavelength oximeter was considered an accurate device, but because bulky fiber optic cables were needed to carry the light source to the patient and the transmitted light back to a light sensor, it was impractical (Rebuck *et al* 1983). Probes for the pulse oximeter are not only smaller, but can be disposable.

Figure 3.10 shows a transmission pulse oximeter and a reflectance pulse oximeter. As the names indicate, a transmission pulse oximeter measures the amount of light that passes through the tissue as in a finger probe. A reflectance pulse oximeter measures the amount of light reflected back to the probe. Both types use the same technology differing only in positioning of the probes and calibration.

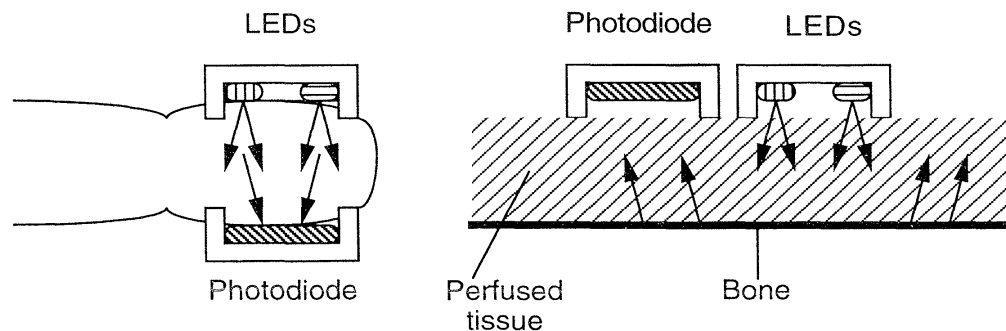

**Figure 3.10** On the left is a transmission pulse oximeter measuring the transmission of light by two LEDs through the finger of a patient. On the right is a reflectance pulse oximeter measuring the amount of light reflected back to the probe.

3.7.5 Analog amplifier and signal processing

The photodiode generates a current proportional to the intensity of light. The analog amplifier converts this current to a voltage. Because the change in voltage due to the pulsations of the arteries is small in comparison to the dc portion of the signal, the dc component of the signal is subtracted from the rest of the signal by the demodulator. The demodulator also uses a sample-and-hold timing circuit to separate samples from the red LED from the samples of the infrared LED. The ac portions of these signals are low-pass filtered to remove electromagnetic interference. Then each signal goes through a programmable gain circuit after which a multiplexer with another sample-and-hold circuit modulates the red and infrared signals back into one to go through an analog-to-digital converter (ADC) for use by the microprocessor.

Using the data gathered from the ADC, the microprocessor calculates what is called a ratio of ratios. From this ratio of ratios and the value of the coding resistor, the microprocessor goes to an empirical look up table for its  $S_pO_2$  value. The empirical look up table is generated by the manufacturer through laboratory tests done with a CO-oximeter. The signal processing algorithms also provide some noise reduction. Some pulse oximeters use an ECG in their signal processing algorithm to minimize errors due to motion artifacts.

3.7.6 A three-wavelength pulse oximeter for COHb determination

Current pulse oximeters estimate the arterial oxygen saturation of the blood by measuring absorbances at two wavelengths of light. Because of this, the pulse oximeter is only able to account for Hb and HbO<sub>2</sub>. Increased levels of COHb, for example, will cause an overestimation in  $S_aO_2$  because the pulse oximeter cannot distinguish between HbO<sub>2</sub> and COHb. In cases of carbon-monoxide poisoning, this could have terrible consequences if the clinician is unaware.

**Table 3.1** A comparison of pulse oximetry and transcutaneous  $PO_2$  electrodes from New (1985), Barker and Tremper (1984), and Severinghaus (1987).

Pulse oximeters	Transcutaneous $P_{tc}O_2$ electrodes
Require no heating	Have internal heaters which can cause burns and must be moved periodically to avoid skin damage, especially in infants
Have no delay	Require skin and electrode preparation and a warm up period of up to ten minutes
Never require user calibration	Require recalibration
Probes are clipped or taped on	Require operator skill to place monitor
Measure a pure respiratory variable ( $S_aO_2$ ) and a pure circulatory variable (plethysmograph)	Are a sensitive, but not specific, monitor of blood oxygenation; a drop in $P_{tc}O_2$ may be caused by respiratory deficiency, circulatory deficiency, or both
Give an accurate reading or none at all	Report low $PO_2$ when electrode may not be placed well
Require pulsating arteries; fails during cardiac arrest, cardiopulmonary bypass, or distal placement to blood pressure cuff.	Detect low cardiac output
Require hemoglobin in the bloodstream and may fail with severe anemia or hemodilution	Are not dependent on hemoglobin
Can be in error with high levels of dyshemoglobin species present in the blood	
Display pulse rate	Do not display pulse rate

Buinevicius (1987) designed a three wavelength pulse oximeter to solve this problem. An additional LED at 810 nm was used in an attempt to determine the amount of COHb in the blood. Buinevicius also presented a method to calibrate the pulse oximeter for three wavelengths using three-dimensional solutions to Beer's law.

### 3.7.7 Comparison of pulse oximetry to transcutaneous PO<sub>2</sub> electrodes

Pulse oximeters and transcutaneous PO<sub>2</sub> electrodes are the two main technologies used to provide continuous information about the supply of oxygen to the body. Table 3.1 provides a comparison between the two technologies.

## REFERENCES

- Adams A P and Hahn C E W 1982 *Principles and practice of blood-gas analysis* 2nd edn (New York: Churchill Livingstone)
- Barker S J 1991 Pulmonary artery oximetry *Proc. Optical Fibers in Medicine VI*, (Los Angeles, CA 1991) (Bellingham, WA: SPIE Optical Engineering Press)
- Barker S J and Tremper K K 1984 Transcutaneous oxygen tension: a physiological variable for measuring oxygenation *J. Clin. Monitoring* **1** (2) 130–4
- Buinevicius R P 1987 A three wavelength pulse oximeter for carboxyhemoglobin determination *MSc thesis*, Department of Electrical and Computer Engineering, University of Wisconsin-Madison
- Burtus C A and Ashwood E R 1994 *Tietz Textbook of Clinical Chemistry* 2nd edn (Philadelphia PA: Saunders)
- Dennis R C and Valeri C R 1980 Measuring percent oxygen concentration of hemoglobin, percent carboxyhemoglobin and methemoglobin, and concentrations of total hemoglobin and oxygen in blood of man, dog and baboon *Clin. Chem.* **26** 1304–8
- Gradwohl R B H 1948 *Clinical Laboratory Methods and Diagnosis* 4th edn (St. Louis, MO: Mosby)
- Gothgen I H and Jacobsen E 1987 Computing the oxygen status of the blood from heated skin PO<sub>2</sub> *Continuous transcutaneous monitoring* ed A Huch, R Huch and G Rooth (New York: Plenum)
- Hill D W 1966 Methods of measuring oxygen content of blood *Oxygen Measurements in Blood and Tissues and their Significance* ed J P Payne and D W Hill (Boston: Little, Brown) **4** (1) 63–80
- Merrick E B and Hayes T J 1976 Continuous non-invasive measurements of arterial blood oxygen levels *Hewlett-Packard J.* **28** (2) 2–9
- Miller S E 1966 *A Textbook of Clinical Pathology* 7th edn (Baltimore, MD: Williams and Wilkins)
- Moyle J T B 1994 *Pulse Oximeters* (London: BMJ)
- New W Jr 1985 Pulse oximetry *J. Clin. Monitoring* **1** (2) 126–9
- Nilsson N J 1960 Oximetry *Physiol. Rev.* **40** 1–22
- Ono K, Masahiko K, Hiramoto J, Yotsuya K and Sato N 1991 Fiber optic reflectance oximeter spectrophotometry system for in vivo tissue diagnosis *Appl. Opt.* **30** 98–104
- Payne J P and Severinghaus J W (eds) 1986 *Pulse Oximetry* (London: Springer)
- Peterson J F 1986 The development of pulse oximetry *Science* **232** G135–40
- Peterson J I and Fitzgerald R V 1984 Fiber-optic probe for in vivo measurement of oxygen partial pressure *Anal. Chem.* **56** 62–7
- Peura R A 1998 Chemical biosensors *Medical Instrumentation: Application and Design* 3rd edn, ed J G Webster (New York: Wiley)
- Polanyi M L and Hehir R M 1962 In vivo oximeter with fast dynamic response *Rev. Sci. Instrum.* **33** 1050–4 (Reprinted 1990 *Selected Papers on Optical Fibers in Medicine* ed B Thompson (Bellingham WA: SPIE Optical Engineering Press))
- Pologe J A 1987 Pulse oximetry: technical aspects of machine design *Int. Anesthesiol. Clinics* **25** (3) 137–53
- Rebuck A S, Chapman K R and D'Urzo A 1983 The accuracy and response characteristics of a simplified ear oximeter *Chest* **83** 860–4
- Santamaria T and Williams J S 1994 Pulse oximetry *Med. Dev. Res. Rep.* **1** (2) 8–10

- Severinghaus J and Astrup P 1987 History of blood gas analysis *Int. Anesthesiol. Clinics* **25** (4) 1–225
- Severinghaus J W 1987 History, status, and future of pulse oximetry *Continuous transcutaneous monitoring* ed A Huch, R Huch and G Rooth (New York: Plenum)
- Shapiro B A, Harrison R A, Cane R D and Templin R 1989 *Clinical Application of Blood Gases* 4th edn (Chicago: Year Book Medical)
- Waxman K, Sadler R, Eisner M E, Applebaum R, Tremper K K and Mason G R 1983 Transcutaneous oxygen monitoring of emergency department patients *Am. J. Surg.* **146** 35–7
- Wukitsch M W, Peterson M T, Tobler D R and Pologe J A 1988 Pulse oximetry: analysis of theory, technology and practice *J. Clin. Monitoring* **4** (4) 290–301
- Zijlstra W G 1958 *A Manual on Reflection Oximetry* (Assen: Van Gorcum)
- Zwart A, Buursma A, Oeseburg B and Zijlstra W G 1981 Determination of hemoglobin derivatives with the IL-282 CO-oximeter as compared with a manual spectrophotometric five wavelength method *Clin. Chem.* **27** (11) 1903–6

## INSTRUCTIONAL OBJECTIVES

- 3.1 Explain why transcutaneous  $PO_2$  electrodes require the skin to be heated.
- 3.2 Explain why a CO-oximeter uses hemolyzed blood samples to determine the hemoglobin components of the blood.
- 3.3 Explain the difference between absorptivity and absorbance.
- 3.4 Describe a noninvasive two-wavelength oximeter and its problems.
- 3.5 Describe a two-wavelength fiber optic oximeter.
- 3.6 Describe an eight-wavelength oximeter.
- 3.7 Describe how pulse oximeters overcome some of the problems of earlier oximeters.
- 3.8 Explain the need for a coding resistor in a pulse oximeter probe.
- 3.9 Explain why Beer's law cannot be used for direct computation of  $S_pO_2$  and empirical lookup tables are used instead.
- 3.10 Given the concentrations of oxyhemoglobin and reduced hemoglobin for blood, calculate  $S_pO_2$ .
- 3.11 Explain why a pulse oximeter might not be as accurate for a patient who is a smoker.
- 3.12 Describe a three-wavelength pulse oximeter to determine COHb concentration and explain it might be more accurate for a patient who is a smoker than a two-wavelength pulse oximeter.



## CHAPTER 4

---

# LIGHT ABSORBANCE IN PULSE OXIMETRY

*Oliver Wieben*

This chapter describes the theoretical background for the measurement of light absorbance in pulse oximetry as a basis for determining arterial oxygen saturation. Beer's law and the derivation of a theoretical calibration curve for measured light absorbances in pulse oximeters is explained, although this curve is not valid in practice due to the scattering of light. Beer's law is used accurately to determine the oxygen saturation of hemoglobin solutions but does not apply for whole blood because of the scattering effects. Nevertheless, this model helps to develop an understanding of the absorbance of light as it passes through living tissue and why and how pulse oximetry works. The normalization of the measured signals and the calibration curves used in pulse oximeters are explained after an introduction of the theoretical model. The final part of the chapter describes mathematical approaches to incorporate light scattering in the model and describe its effects qualitatively and quantitatively.

### 4.1 BEER'S LAW

*Beer's law* (also referred to as Beer–Lambert's or Bouguer's law) describes the attenuation of light traveling through a uniform medium containing an absorbing substance. If monochromatic incident light of an intensity  $I_0$  enters the medium, a part of this light is transmitted through the medium while another part is absorbed. The intensity  $I$  of light traveling through the medium decreases exponentially with distance

$$I = I_0 e^{-\varepsilon(\lambda)cd} \quad (4.1)$$

where  $\varepsilon(\lambda)$  is the *extinction coefficient* or absorptivity of the absorbing substance at a specific wavelength,  $c$  the concentration of the absorbing substance which is constant in the medium, and  $d$  the optical path length through the medium (see figure 4.1). The concentration  $c$  is measured in  $\text{mmol L}^{-1}$  and the extinction coefficient is expressed in  $\text{L mmol}^{-1} \text{cm}^{-1}$ .

Beer's law is based on the property that the sum of transmitted and absorbed light equals the incident light. It does not account for physical processes which include reflection of the light at the surface of the medium or scattering of light in the medium.

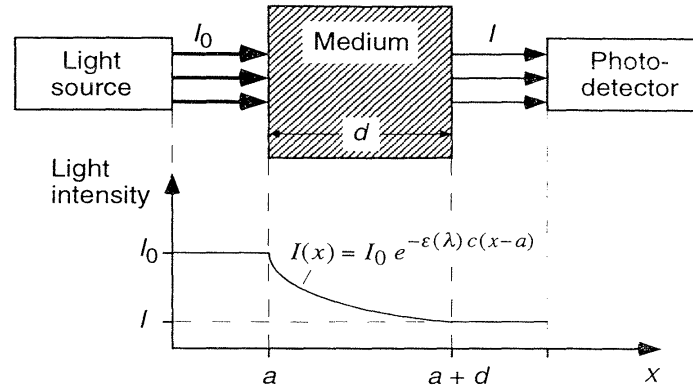

**Figure 4.1** Beer’s law: Incident light of intensity  $I_0$  travels the distance  $a$  from a light source to the medium without being absorbed in the air. The light intensity decreases exponentially with distance in the absorbing medium. The intensity of the transmitted light  $I$  is determined by Beer’s law. It stays constant after exiting the medium with optical path length  $d$  and can be measured by a photodetector.

#### 4.1.1 Transmittance and absorbance of light

The *transmittance* ( $T$ ) of light traveling through a medium with an absorbing substance is defined as the ratio of transmitted light  $I$  to the incident light  $I_0$

$$T = \frac{I}{I_0} = e^{-\epsilon(\lambda)cd}. \tag{4.2}$$

The *unscattered absorbance* ( $A$ ) of this process is defined as the negative natural logarithm of the transmittance of light

$$A = -\ln T = \epsilon(\lambda)cd. \tag{4.3}$$

The absorbance is sometimes referred to as the optical density of a medium.

#### 4.1.2 Multiple absorbers

The properties of Beer’s law are valid even if more than one substance absorbs light in the medium. Each absorber contributes its part to the total absorbance. The mathematical representation of this system of absorbers is a superposition of the individual absorbing processes. The resulting *total absorbance*  $A_t$  of light in a medium with  $n$  absorbing substances is the sum of their  $n$  independent absorbances

$$A_t = \epsilon_1(\lambda)c_1 d_1 + \epsilon_2(\lambda)c_2 d_2 + \dots + \epsilon_n(\lambda)c_n d_n = \sum_{i=1}^n \epsilon_i(\lambda)c_i d_i \tag{4.4}$$

where  $\epsilon_i(\lambda)$  and  $c_i$  represent the extinction coefficient and concentration of the substance  $i$  and  $d_i$  represents the optical path length through the absorbing substance, which may differ from substance to substance in the medium.

Therefore, Beer's law allows us to determine the unknown concentrations of  $n$  different absorbing substances in a homogeneous medium if the absorbance of light is measured at  $n$  different wavelengths and the extinction coefficients of the substances are known.

## 4.2 HEMOGLOBIN EXTINCTION COEFFICIENTS

Hemoglobin is the main light absorber in human blood at wavelengths used in pulse oximetry. The absorbing characteristics of hemoglobin change with its chemical binding and the wavelength of the incident light. Although oxygenated and reduced hemoglobin absorb most of the light passing through blood, they do not represent the only two hemoglobin species present in human blood. Hemoglobin may combine with other substances such as carbon monoxide or hydrogen sulfide as well, which changes its color.

### 4.2.1 Functional hemoglobins

Binding oxygen in the pulmonary capillaries and releasing it in the systemic capillaries is the main purpose of hemoglobin. Hemoglobins that are able to bind reversibly with molecular oxygen are called *functional hemoglobins*.

When hemoglobin is fully saturated with oxygen (carrying four oxygen molecules), it is called *oxyhemoglobin* ( $\text{HbO}_2$ ). If it is not fully saturated with oxygen it is called *reduced hemoglobin* ( $\text{Hb}$ ). Therefore oxyhemoglobin and reduced hemoglobin are functional hemoglobins.

Most of the hemoglobins in a healthy individual are functional hemoglobins. The *functional oxygen saturation* (functional  $\text{SO}_2$ ) is measured in percentage and determined by the amount of oxygenated hemoglobin ( $\text{HbO}_2$ ) as compared to the sum of oxygenated and reduced hemoglobin ( $\text{Hb}$ ). Another way to define this ratio is to use the concentrations of oxygenated hemoglobin ( $c_{\text{HbO}_2}$ ) and reduced hemoglobin ( $c_{\text{Hb}}$ )

$$\text{Functional } \text{SO}_2 = \frac{\text{HbO}_2}{\text{Hb} + \text{HbO}_2} \times 100\% = \frac{c_{\text{HbO}_2}}{c_{\text{HbO}_2} + c_{\text{Hb}}} \times 100\%. \quad (4.5)$$

The functional oxygen saturation of explicitly arterial blood is called functional arterial oxygen saturation (functional  $S_a\text{O}_2$ ) and is referred to as functional hemoglobin saturation as well.

### 4.2.2 Dysfunctional hemoglobins

*Dysfunctional hemoglobins* (or dyshemoglobins) do not support the transport of oxygen to the tissues. They are either unable to bind reversibly to oxygen or interfere with the ability of oxyhemoglobin to release its oxygen to the tissue.

The four most common dyshemoglobins are methemoglobin (MetHb), carboxyhemoglobin (COHb), sulfhemoglobin, and carboxysulfhemoglobin.

**4.2.2.1 Methemoglobin.** Methemoglobin is oxidized hemoglobin. It is a result of oxidation of a free heme iron ( $\text{Fe}^{2+}$ ) instead of the reversible binding of oxygen to heme inserted into globin subunits.

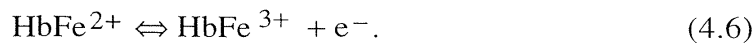

An enzyme system (including cytochrome b<sub>5</sub>) is responsible for reducing the methemoglobin in the red cells by maintaining hemoglobin in the reduced state (Fe<sup>2+</sup>).

Oxidized hemoglobin subunits are not capable of binding oxygen and altering the oxygen binding of the remaining ferrous hemes. Therefore, methemoglobin has a great influence on the functionality of hemoglobin. Under physiological circumstances the amount of methemoglobin remains below 0.6% of the total hemoglobin and this amount varies at a rate of 2 to 3% during the day. The absorbance spectrum of methemoglobin is strongly pH-dependent (Bunn 1986).

*4.2.2.2 Carboxyhemoglobin.* Carboxyhemoglobin is formed when hemoglobin combines with carbon monoxide (CO). The carbon atom of carbon monoxide is bonded to the iron atom of heme.

The affinity of hemoglobin binding with carbon monoxide is approximately 210 times larger than that of oxygen. Therefore, the presence of a high level of carbon monoxide will reduce the amount of oxygenated hemoglobin significantly. The level of carboxyhemoglobin in the blood varies with the habits and surroundings of the individual. Smoking, working in underground garages, traffic tunnels, mines, etc. increases the amount of CO in the blood. In nonsmokers the level of COHb is usually below 2% but this value varies with the local environment (Wukitsch *et al* 1988).

*4.2.2.3 Sulfhemoglobin and carboxysulfhemoglobin.* The reaction of oxyhemoglobin and hydrogen sulfide produces sulfhemoglobin. The relevant chemical reactions are complex and not thoroughly understood, although the absorbance spectrum of sulfhemoglobin is known.

The oxygen affinity of the heme iron in sulfhemoglobin is 100-fold lower than the oxygen affinity of unmodified hemoglobin (Bunn 1986). This chemical reaction is irreversible (Nellcor 1993). Carboxysulfhemoglobin results from a reaction of sulfhemoglobin with carbon monoxide. The concentrations of sulfhemoglobin and carboxysulfhemoglobin in human blood are usually not significant.

*4.2.2.4 Fractional hemoglobin saturation.* The *fractional oxygen saturation* is the fraction of oxygenated hemoglobin to the total hemoglobin. It is usually measured in percentage as well and is determined by the ratio of the concentrations of oxygenated hemoglobin to total hemoglobin

$$\text{Fractional } \text{SO}_2 = \frac{c_{\text{HbO}_2}}{c_{\text{total hemoglobin}}} \times 100\% \quad (4.7)$$

where total hemoglobin represents all different species of hemoglobin present in the blood.

### 4.2.3 Hemoglobin absorbance spectra

The chemical binding of the different hemoglobin species changes the physical properties of the hemoglobin as well. Figure 4.2 shows the extinction coefficients of oxyhemoglobin, reduced hemoglobin, methemoglobin and carboxyhemoglobin at wavelengths in the range of interest in pulse oximetry.

The absorbance of light in the red region of the spectrum is much higher for reduced hemoglobin than for oxyhemoglobin. The extinction coefficients of both hemoglobin species are equal at the point isosbestic point (805 nm). The reduced hemoglobin is more transparent to light from the infrared region than oxyhemoglobin.

The extinction coefficient of carboxyhemoglobin is about the same as that of oxyhemoglobin at the wavelength of 660 nm while it is almost transparent in the infrared region. Methemoglobin absorbs much light in the red region of the spectrum and its extinction coefficient remains higher than that of oxyhemoglobin in the infrared region.

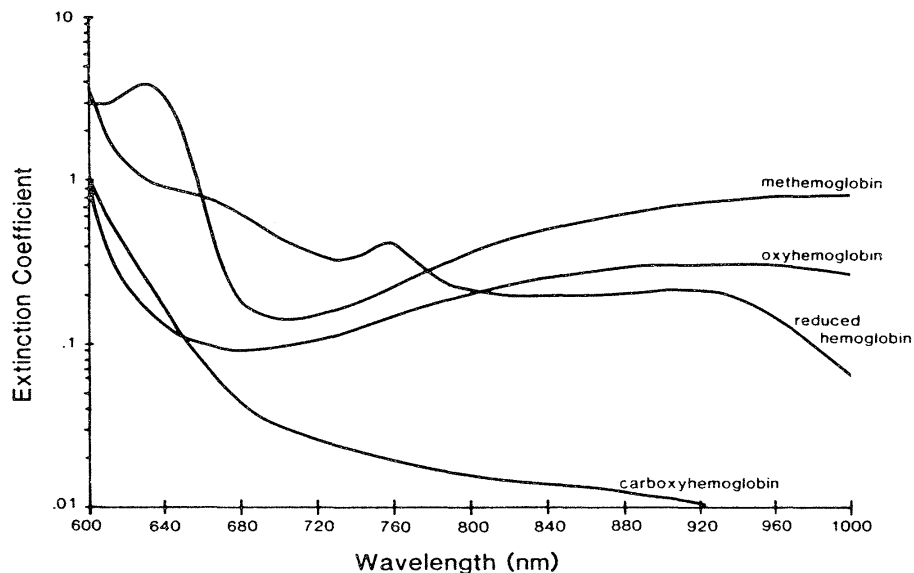

**Figure 4.2** Extinction coefficients of the four most common hemoglobin species oxyhemoglobin, reduced hemoglobin, carboxyhemoglobin, and methemoglobin at the wavelengths of interest in pulse oximetry (courtesy of Susan Manson, Biox/Ohmeda, Boulder, CO).

### 4.3 BEER'S LAW IN PULSE OXIMETRY

Pulse oximeters determine the oxygen saturation of arterial blood by measuring the light absorbance of living tissue at two different wavelengths and using the arterial pulsation to differentiate between absorbance of arterial blood and other absorbers.

### 4.3.1 Criteria for the choice of wavelengths

Different reasons lead to the most common choice for wavelengths used in pulse oximetry. The red skin pigmentation absorbs a great amount of light at wavelengths shorter than 600 nm and therefore it is not desirable to measure light absorbance in this range. Large differences in the extinction coefficients of reduced hemoglobin and oxygenated hemoglobin change the absorbance of light significantly, even when the oxygen saturation changes slightly. A good choice for a wavelength in the red region is 660 nm because of a large difference in the extinction coefficients.

Another issue for the wavelength choice is flatness of the absorption spectra shown in figure 4.2 around the chosen wavelength. Otherwise shifts in the peak wavelength of the LEDs (see section 5.3) will result in a larger error. The absorbance spectra of reduced hemoglobin and oxygenated hemoglobin are relatively flat at 660 and 940 nm (Moyle 1994).

Mannheimer *et al* (1997) have shown that sensors fabricated with 735 and 890 nm emitters read more accurately at low saturations under a variety of conditions, while 660 and 990 nm emitters read more accurately at high saturations.

### 4.3.2 Absorbance in hemoglobin solutions

The different species of hemoglobin are the main light absorbers in arterial and venous blood. Most of the hemoglobin in human blood is either oxygenated or reduced hemoglobin which determine the functional oxygen saturation  $SO_2$  (equation (4.5)). The concentrations of oxygenated hemoglobin ( $c_{HbO_2}$ ) and reduced hemoglobin ( $c_{Hb}$ ) can be expressed as a function of  $SO_2$  as a fraction and the sum of the concentrations  $c_{HbO_2}$  and  $c_{Hb}$

$$c_{HbO_2} = SO_2 (c_{HbO_2} + c_{Hb}) \quad (4.8)$$

$$c_{Hb} = (1 - SO_2)(c_{HbO_2} + c_{Hb}). \quad (4.9)$$

According to Beer's law we derive the total absorbance  $A_t$  of a solution containing only reduced and oxygenated hemoglobin as absorbing substances from equation (4.4)

$$A_t = \varepsilon_{HbO_2}(\lambda) c_{HbO_2} d_{HbO_2} + \varepsilon_{Hb}(\lambda) c_{Hb} d_{Hb}. \quad (4.10)$$

Assuming that the optical path length  $d$  is the same for the oxygenated hemoglobin ( $d_{HbO_2}$ ) and reduced hemoglobin ( $d_{Hb}$ ) and using equations (4.8), (4.9), and (4.10), we derive

$$A_t = [\varepsilon_{HbO_2}(\lambda) SO_2 + \varepsilon_{Hb}(\lambda)(1 - SO_2)] (c_{Hb} + c_{HbO_2}) d. \quad (4.11)$$

Thus  $A_t$  can be expressed for known concentrations of hemoglobin in terms of functional oxygen saturation as a fraction, the extinction coefficients of hemoglobin, and the length of the optical path. Values for the extinction coefficients of adult reduced hemoglobin ( $\varepsilon_{Hb}$ ) and adult oxygenated hemoglobin

( $\epsilon_{\text{HbO}_2}$ ) at the two wavelengths most commonly used in pulse oximetry (660 nm and 940 nm) have been measured by Zijlstra *et al* (1991) (see table 4.1).

**Table 4.1** Table of extinction coefficients of reduced and oxygenated hemoglobin in adults at the wavelengths of 660 nm and 940 nm (values from Zijlstra *et al* 1991).

Wavelength, nm	Extinction coefficient, L mmol <sup>-1</sup> cm <sup>-1</sup>	
	Hb	HbO <sub>2</sub>
660	0.81	0.08
940	0.18	0.29

Figure 4.3 shows the characteristics of light absorbance for a sample with a fixed concentration of total functional hemoglobin ( $c_{\text{HbO}_2} + c_{\text{Hb}}$ ) of 1 mmol L<sup>-1</sup>, a fixed path length  $d$  of 1 cm and varying functional oxygen saturations. The two lines shown in figure 4.4 represent the properties for the two most commonly used wavelengths in pulse oximetry (660 nm and 940 nm). The absorbance of light at a wavelength of 940 nm increases with an increased oxygen saturation. At 660 nm the absorbance of light decreases rapidly with an increasing functional oxygen saturation (Pologe 1987).

It is possible to determine the concentrations of hemoglobins in hemoglobin solutions or hemolyzed blood by using a device such as a spectrophotometer (see section 3.3).

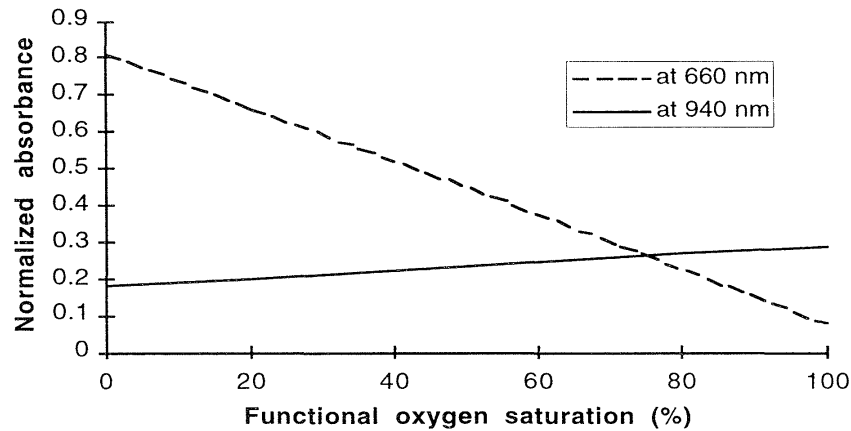

**Figure 4.3** Changes in light absorbance in hemoglobin solutions as a function of functional oxygen saturation for the wavelengths used in pulse oximetry. Absorbance decreases rapidly with increasing oxygen saturation at 660 nm (dashed line) but increases slightly with increasing oxygen saturation at 940 nm (solid line).

#### 4.3.3 Pulsation of the blood

Light traveling through biological tissue (e.g. the finger or earlobe) is absorbed by different absorbing substances. Primary absorbers of light in the region of interest are the skin pigmentation, bones, and the arterial and venous blood. Instead of measuring the arterial oxygen saturation of the blood *in vitro* with a sample of arterial blood and a spectrophotometer, or at a wide range of different wavelengths as with the Hewlett-Packard ear oximeter, pulse oximeters take

advantage of *arterial pulsation*. Figure 4.5 shows the amount of absorbed and transmitted light in living tissue as a function of time.

The arteries contain more blood during systole than during diastole, and therefore, their diameter increases due to increased pressure. This effect occurs only in the arteries and arterioles but not in the veins. The absorbance of light in tissues with arteries increases during systole mainly because of the larger amount of absorbing substances (hemoglobin), due to the fact that the optical path length  $d$  in the arteries increases. This alternating part of the total absorbance allows us to differentiate between the absorbance due to venous blood, a constant amount of arterial blood, and other nonpulsatile components such as skin pigmentation (dc component of the total absorbance) and the absorbance due to the pulsatile component of the arterial blood (ac component). The alternating part of the light absorbed by the living tissue usually does not exceed 1% to 2% of the constant absorbance of the dc components. The time varying signal of transmitted light is referred to as the plethysmographic (or photoplethysmographic) signal.

The intensity of the light passing through the tissue during diastole is high ( $I_H$ ). The absorbers that are present during diastole are the DC components. All DC components except the nonpulsating arterial blood are collectively represented by  $\epsilon_{DC}(\lambda)$ ,  $c_{DC}$ , and  $d_{DC}$ . The diameter of the arterial vessels is minimal ( $d_{min}$ ) and therefore the absorbance due to arterial hemoglobin is minimal and the amount of transmitted light is high ( $I_H$ ) and has a peak (see figures 4.4 and 4.5)

$$I_H = I_0 e^{-\epsilon_{DC}(\lambda)c_{DC}d_{DC}} e^{-[\epsilon_{Hb}(\lambda)c_{Hb} + \epsilon_{HbO_2}(\lambda)c_{HbO_2}]d_{min}} \quad (4.12)$$

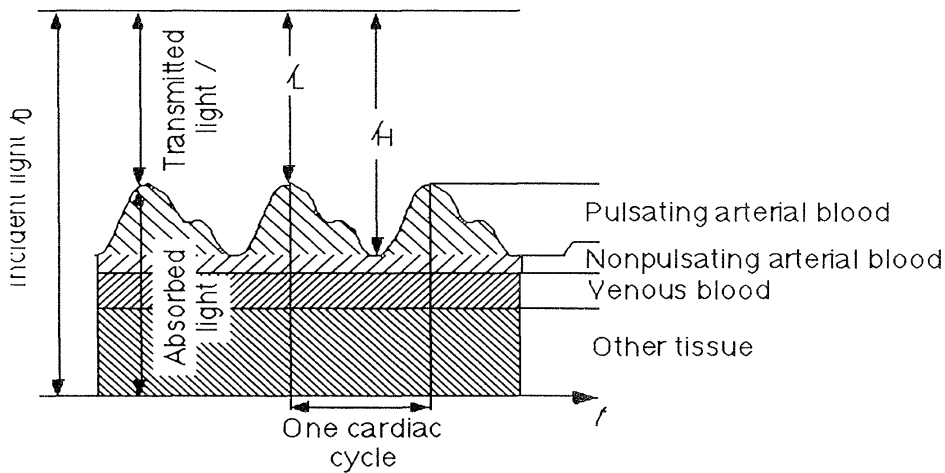

**Figure 4.4** Absorbed and transmitted light in living tissue. The amount of absorbed light correlates with the pulsation of arterial blood. A constant amount of light is absorbed by the skin pigmentation, bone, other tissue, venous blood and the nonpulsating part of the arterial blood. More blood is present in the arteries during systole and therefore more light is absorbed. The intensity of the transmitted light varies from  $I_H$  (maximum) to  $I_L$  (minimum) within one cardiac cycle.

The optical path length in the arteries increases during the systole to  $d_{max}$ . The amount of absorbed light reaches a maximum peak and therefore the transmitted light reaches the low peak  $I_L$ :



$$I_L = I_0 e^{-\epsilon_{DC}(\lambda)c_{DC}d_{DC}} e^{-[\epsilon_{Hb}(\lambda)c_{Hb} + \epsilon_{HbO_2}(\lambda)c_{HbO_2}]d_{max}}. \quad (4.13)$$

The light intensity  $I$  of the light arriving at the photodetector is a function of the diameter  $d$  of the arteries and arterioles. During one cardiac cycle this diameter changes from  $d_{min}$  to  $d_{max}$ . By substituting  $d$  with  $d_{min} + \Delta d$  we derive the following expression from Beer's law, where  $I$  is expressed as a function of  $I_H$  and  $\Delta d$ , the part of the diameter that changes from 0 to  $d_{max} - d_{min}$  with time

$$I = I_H e^{-[\epsilon_{Hb}(\lambda)c_{Hb} + \epsilon_{HbO_2}(\lambda)c_{HbO_2}]\Delta d}. \quad (4.14)$$

Figure 4.5 shows these properties in a simplified model.

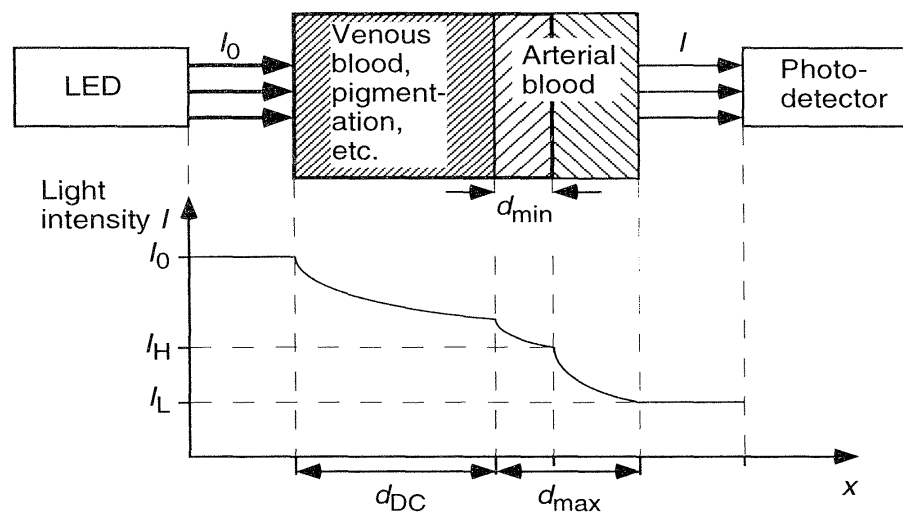

**Figure 4.5** Beer's law in pulse oximetry. The DC components of the tissue (e.g. skin pigmentation, bone, venous blood and the nonpulsating part of the arterial blood) absorb a constant amount of the incident light  $I_0$ . The effective optical path length in the DC components without the constant level of arterial blood is represented by  $d_{DC}$ . During diastole the optical path length through the arteries has a minimum length of  $d_{min}$  and the light intensity at the photodetector is maximal ( $I_H$ ). The optical path length reaches a maximum  $d_{max}$  during systole and the hemoglobin in the arteries absorbs a maximum amount, causing  $I$  to decrease to a minimum level of  $I_L$ .

#### 4.3.4 Measurement of pulse oximeters

The reading of the pulse oximeter  $S_pO_2$  is an estimation of the arterial oxygen saturation  $S_aO_2$ . Measuring at two wavelengths allows us to distinguish the concentrations of only two different absorbers (Hb and  $HbO_2$ ). But in humans more species of hemoglobin, such as carboxyhemoglobin and methemoglobin, are present. These other hemoglobins absorb light as the functional hemoglobins do and therefore influence our measurements. As long as we do not measure at as many wavelengths as absorbers are present in the blood, we can not determine the concentrations of Hb and  $HbO_2$  and therefore the arterial oxygen saturation correctly (Barker and Tremper 1987).

Due to the fact that Hb and HbO<sub>2</sub> are the main absorbers, the error may be small. Nevertheless, the results of determining either the actual functional or fractional oxygen saturation (see equations (4.5) and (4.7)) of the arterial blood are not exact. This problem is also discussed in sections 10.1.1 and 11.1.1. The oximeter reading becomes less accurate if the concentrations of dyshemoglobins are larger than in normal humans. Section 11.7 deals with the presence of high concentrations of dysfunctional hemoglobins.

#### 4.4 SATURATION VERSUS NORMALIZED RATIO

The arterial oxygen saturation can be derived based on Beer's law as a function of the ratio of absorbances at two wavelengths. Due to nonlinearities in the LEDs, the photodetector, and light absorbance in the tissue, the absorbances have to be normalized in the ratio. This model results in a theoretical calibration curve, but it is not used in practice as will be described in the following sections.

##### 4.4.1 Normalization

The measured light intensities at the different wavelengths have to be *normalized* before they can be compared with each other due to the fact that the light-emitting diodes (LEDs) may emit light with different intensities. The absorbing characteristics of the DC components and the sensitivity of the photodetector differ for the two different wavelengths and the tissue absorption and path length varies widely from patient to patient and with the probe site (de Kock and Tarassenko 1991). The normalized signal  $I_n$  is calculated by dividing the transmitted light intensities (the *raw signals*) by their individual maximum peaks ( $I_{H,R}$  for the red wavelength and  $I_{H,IR}$  for the infrared wavelength). From equation (4.14) we derive

$$I_n = \frac{I}{I_H} = e^{-[\varepsilon_{Hb}(\lambda)c_{Hb} + \varepsilon_{HbO_2}(\lambda)c_{HbO_2}]\Delta d}. \quad (4.15)$$

This results in normalized signals with the same intensities  $I_{H,n}$  during diastole. The normalized signals of the transmitted red and infrared light are independent of the incident light levels and photodetector nonlinearities as shown in figure 4.6. The AC components of the normalized signals represent only changes of transmitted light caused by the pulsation of blood in the arteries and can be compared with each other. They depend on the absorbers present in the arterial blood (ideally Hb and HbO<sub>2</sub>) and the actual optical path length  $d$  through the volume changing part of the arteries.

##### 4.4.2 Ratio of normalized signals

The absorbance of the light is derived by calculating the natural logarithm of the measured and normalized transmitted light level. Dividing the raw signal by the transmitted light during diastole  $I_H$  as in equation (4.15) and calculating the total absorbance then is comparable to calculating the total absorbance only due to the AC components in the pathway. The transmitted light during diastole represents the new nonchanging incident light level and the *ratio*  $R$  of these normalized

absorbances at the red (R) and infrared (IR) wavelengths depends only on the light absorbers present in the arterial blood (see equation (4.3))

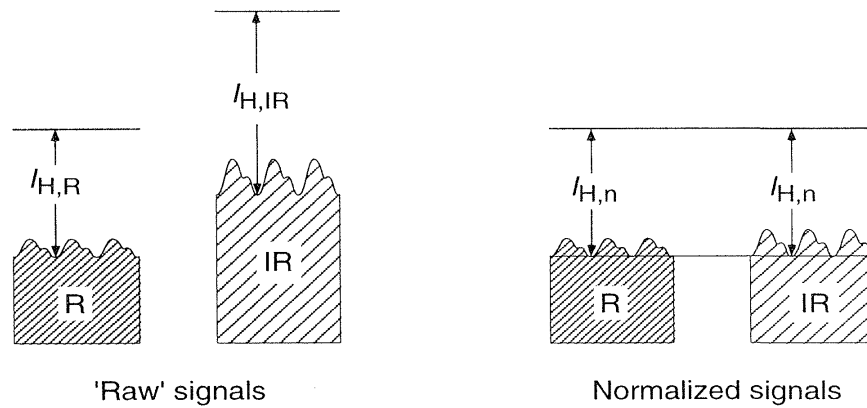

**Figure 4.6** The normalization of the signals. The transmitted light from the red LED (R) and from the infrared LED (IR) is divided by its individual DC component. Thus, both normalized light intensities have the same magnitude during diastole. The normalized signals determine the basis for the calculation of the arterial oxygen saturation.

$$R = \frac{A_{t,R}}{A_{t,IR}} = \frac{\ln(I_{L,R} / I_{H,R})}{\ln(I_{L,IR} / I_{H,IR})} \quad (4.16)$$

By using equation (4.15) the ratio can be derived as

$$R = \frac{[(\epsilon_{Hb}(\lambda_R)c_{Hb} + (\epsilon_{HbO_2}(\lambda_R)c_{HbO_2})]\Delta d_R}{[(\epsilon_{Hb}(\lambda_{IR})c_{Hb} + (\epsilon_{HbO_2}(\lambda_{IR})c_{HbO_2})]\Delta d_{IR}} \quad (4.17)$$

Assuming that the optical path lengths  $d_R$  for red light and  $d_{IR}$  for the infrared light are equal, only the arteries change their diameter, and using equation (4.11)

$$R = \frac{\epsilon_{Hb}(\lambda_R) + [\epsilon_{HbO_2}(\lambda_R) - \epsilon_{Hb}(\lambda_R)]S_aO_2}{\epsilon_{Hb}(\lambda_{IR}) + [\epsilon_{HbO_2}(\lambda_{IR}) - \epsilon_{Hb}(\lambda_{IR})]S_aO_2} \quad (4.18)$$

In this form the ratio  $R$  is not a function of the optical path length and can be derived from the arterial oxygen saturation instead of the concentration of the hemoglobins in the blood (see de Kock and Tarassenko 1993).

#### 4.4.3 Theoretic calibration curve

Equation (4.18) can be rewritten in a form where  $S_aO_2$  is a function of the measured and calculated ratio  $R$

$$S_aO_2 = \frac{\epsilon_{Hb}(\lambda_R) - \epsilon_{Hb}(\lambda_{IR})R}{\epsilon_{Hb}(\lambda_R) - \epsilon_{HbO_2}(\lambda_R) + [\epsilon_{HbO_2}(\lambda_{IR}) - \epsilon_{Hb}(\lambda_{IR})]R} \times 100\% \quad (4.19)$$

Therefore, the functional oxygen saturation in arterial blood can be derived theoretically by calculating the ratio  $R$  of measured and normalized total light

absorbances in the red and infrared region and using equation (4.19). Figure 4.7 plots this relationship as the *theoretical calibration curve*.

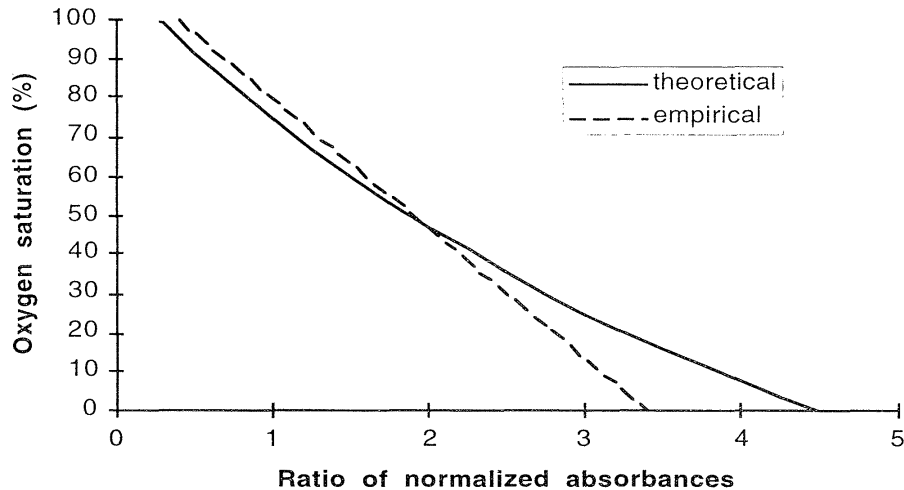

**Figure 4.7** Calibration curves for pulse oximeters: the solid line is the theoretical curve by Beer’s law and the dashed line is the empirical curve. The difference between these curves is due mainly to light scattering effects. This empirical calibration curve is derived by a second order polynomial.

#### 4.5 VALIDITY OF BEER’S LAW IN PULSE OXIMETRY

Incident light passing through human tissue is not split only into absorbed light and transmitted light as proposed by Beer’s law. Some parts of the light are reflected and others are scattered.

Light reflection at the skin surface and light absorbance due to tissue other than the pulsating arterial blood are overcome by using the plethysmographic waveform. However, the skin surface, tissue, muscle, bone and especially blood cause light scattering which increases the absorbance of light (see following section). Blood is a nonhomogeneous liquid, which is capable of nonlinear absorbance of light, e.g. as the concentration of hemoglobins varies (Wukitsch *et al* 1988).

The variation in light absorbance is not entirely due to the increased optical path length during systole. If the change in diameter were the only reason, the variation would be much less. The reason is a change in the axis of the red blood cells, which changes their absorbance as well. Red blood cells have the shape of a biconcave disk. Their major diameter is aligned parallel to the direction of blood flow during diastole and aligns perpendicular to the direction of flow during systole. Therefore, the optical path length is larger during systole and increases light absorbance. Even the light reflectance changes with the axis of the red blood cells, which is important for the use of reflectance probes. As a result of these properties, the absorbance and reflectance of blood in motion varies within the cardiac cycle and with the velocity of blood flow (Moyle 1994).

## 4.6 LIGHT SCATTERING

The results of oximetry measurements with whole blood differ from the results of the theory based on Beer's law. A physical phenomenon called *light scattering* highly increases the absorbance of light. Nevertheless, pulse oximeters read the arterial oxygen saturation of the blood accurately enough for clinical use under normal circumstances. This is due to the fact that most of the commercial pulse oximeters use a calibration curve based on empirical data, because modeling the problem of light scattering mathematically for different conditions is very complex. Several approaches have been made to create models which describe the real process within certain limits of accuracy.

### 4.6.1 *Light absorbance in whole blood*

Unfortunately Beer's law does not apply for whole blood. The absorbance of light is not simply proportional to the concentration of hemoglobin or to the length of the optical path. Beer's law assumes no light scattering, which is not true in whole blood, besides the fact that the LEDs do not emit monochromatic light.

Shymada and Yoshida (1984) verified that the influence of multiple scattering can not be overcome by subtracting the DC level as had been expected. Kramer *et al* (1951) stated that the absorbance of light due to oxyhemoglobin and reduced hemoglobin is increased in whole blood compared to hemolyzed blood by factors of the order of five.

The reasons for the increased absorbance are mainly *scattering* and *multiple scattering*. Light scattering causes the deviation of a light beam from its initial direction. It occurs when light is refracted by an object of a size similar to the magnitude of the wavelength of the light and a change in the index of refraction at the interface of this object. The wavelengths of red and infrared light do have the same order of magnitude as the geometric dimensions of red blood cells (approximately 7  $\mu\text{m}$  in diameter). The discontinuity in the index of refraction at the interface between plasma and red blood cells and the great proportion of red blood cells in blood yield a highly light scattering medium. Light that is scattered once will likely be scattered again by cells and therefore multiple scattering occurs (Steinke and Shepherd 1986). Multiple scattering increases the optical path length and therefore increases the absorbance.

The intensity of the light scattered by the tissue depends on such factors as the red blood cell concentration in the blood; on the size, shape, orientation, and index of refraction of the scattering particles; on the tissue thickness; and on the aperture cone of the detector (Fine and Weinreb 1995). The thickness of the tissue, the distance between the LED and the photodiode, and the concentration of hemoglobin will vary from patient to patient and the shape and orientation of the red blood cells is irregular. Thus it is difficult to develop a physical model which can be used under different circumstances.

### 4.6.2 *Models for light absorbance including scattering*

It would be very useful to find a relationship between  $S_aO_2$  and the ratio  $R$  of normalized absorbances for whole blood instead of only for hemoglobin solutions. An accurate scattering theory for whole blood could replace the

empirical calibration curves used for the  $S_pO_2$  readings. A few attempts are described below.

*4.6.2.1 Twersky's multiple scattering theory.* Twersky (1962, 1970a,b) has developed an analytical theory to describe the scattering of light by large, low-refracting, and absorbing particles. It is based on electromagnetic field theory and uses statistical averages to expand the theory for scattering and absorbing valid for a single particle, to find a formulation valid for multiple scattering (de Kock and Tarassenko 1993).

The total absorbance of whole blood can be expressed as the sum of absorbance as described by Beer's law and a second term representing the attenuation of light due to scattering. These two processes can be treated as independent processes. The intensity of scattering depends on variables such as those mentioned in section 4.6.1. The theory can be adapted for a special setting and will provide accurate results, but once the physiological conditions change, recalibration is required (Fine and Weinreb 1995). Hitachi, Ltd uses Twersky's approach in one of their US patents (Ito *et al* 1993).

*4.6.2.2 Comparison of different models.* Steinke and Sheperd (1986) compared Twersky's theory of radiation scattering and photon diffusion equations. They found Twersky's original equation to give the best fit for the measured data.

Marble *et al* (1994) found the three dimensional photon diffusion theory to be useful for modeling tissue optics although the pulse oximeter system violates many of the requirements of the model. However, they came to the conclusion that this theory can not replace clinical calibration studies.

De Kock and Tarassenko (1993) also found Twersky's theory to give the best fit to the experimental data. They compared results of this model with the photon diffusion theory and the Kubelka-Munk theory.

### *4.6.3 Influence of scattering on pulse oximeter readings*

Although the assumptions of Beer's law are violated in pulse oximetry, the actual readings of the devices show a good correlation between the measurement and the actual arterial oxygen saturation.

Steinke and Sheperd (1986) found that the scattering effects of the light passing through whole blood depend on the wavelength of the light and the oxygen saturation. The relationship between oxygen saturation and total scattering effects (absorbance due to hemoglobin plus multiple scattering) is approximately linear and so scattering does not influence the linearity of the pulse oximeter in a negative way. In contrast, the total absorbance has a larger slope than that due only to the absorbance of hemoglobin following Beer's law. Therefore, light scattering increases the sensitivity of the whole blood oximeter.

Fine and Weinreb (1993, 1995) demonstrate that the ratio of total absorbances is a function of the effective blood layer thickness and the concentration of hemoglobin. Therefore physiological factors such as temperature or peripheral vasoconstriction reduce the accuracy of saturation readings. The error increases as the level of arterial oxygen saturation decreases. This is dangerous because the clinician has to question the readings of the oxygen saturation when it is most critical for the patient.

#### 4.6.4 Calibration curves used for pulse oximeters

Commercial pulse oximeters are calibrated from *in vitro* data (see section 10.1). A large set of data obtained in clinical studies is collected containing information about the ratio  $R$  of the absorbances calculated by the pulse oximeter and the actual arterial oxygen saturation  $S_aO_2$  measured by a very accurate method such as the CO-oximeter (see section 3.3). Lookup tables or equations are used to find the relationship of these two variables for a pulse oximeter reading.

To relate the measured values of the ratio  $R$  to the reading of the pulse oximeter, the equation of the theoretical calibration curve based on Beer's law can be modified as Mendelson and Kent (1989) described

$$S_pO_2 = \frac{k_1 - k_2 R}{k_3 - k_4 R}. \quad (4.20)$$

In this equation the extinction coefficients from equation (4.19) are replaced by constants  $k_i$ . These constants are determined by clinical studies to give the curve a best fit to the *in vitro* measured data. Another approach for a mathematical representation is the use of a polynomial such as found for example in the Ohmeda 3700 and Radiometer OX100 pulse oximeters (Fine and Weinreb 1995)

$$S_pO_2 = k_1 + k_2 R + k_3 R^2. \quad (4.21)$$

Figure 4.7 provides an example of a calibration curve used in pulse oximeters in comparison to the theoretical calibration curve.

#### REFERENCES

- Barker S J and Tremper K K 1987 Pulse oximetry: applications and limitations *Int. Anesthesiol. Clinics* **25** 155–75
- Bunn H F 1986 *Hemoglobin: Molecular, Genetic, and Clinical Aspects* (Philadelphia PA: Saunders)
- Fine I and Weinreb A 1993 Multiple scattering effect in transmission oximetry *Med. Biol. Eng. Comput.* **31** 516–22
- Fine I and Weinreb A 1995 Multiple scattering effect in transmission pulse oximetry *Med. Biol. Eng. Comput.* **33** 709–12
- de Kock J P and Tarassenko L 1991 In vitro investigation of the factors affecting pulse oximetry *J. Biomed. Eng.* **13** 61–6
- de Kock J P and Tarassenko L 1993 Pulse oximetry: theoretical and experimental models *Med. Biol. Eng. Comput.* **31** 291–300
- Ito Y, Kawaguchi F, Yoshida M and Kohida H 1993 Method and equipment for measuring absorbance of light scattering materials using plural wavelengths of light *US patent 5,239,185*
- Kramer K, Elam J O, Saxton G A and Elam W N Jr 1951 Influence of oxygen saturation, erythrocyte concentration and optical depth upon the red and near-infrared light transmittance of whole blood *Am. J. Physiol.* **165** 229–46
- Mannheimer P D, Casciana J R, Fein M E and Nierlich S L 1997 Wavelength selection for low-saturation pulse oximetry *IEEE Trans. Biomed. Eng.* **44** 148–58
- Marble D R, Burns D H and Cheung P W 1994 Diffusion-based model of pulse oximetry: in vitro and in vivo comparisons *Appl. Opt.* **33** 1279–85
- Mendelson Y and Kent J C 1989 Variations in optical absorption spectra of adult and fetal hemoglobins and its effect on pulse oximetry *IEEE Trans. Biomed. Eng.* **36** 844–8
- Moyle J T B 1994 *Pulse Oximeters* (London: BMJ)
- Nellcor 1993 Hemoglobin and the principles of pulse oximetry *Reference Note: Pulse Oximetry Note Number 1* (Pleasanton, CA: Nellcor)

- Pologe J A 1987 Pulse oximetry: technical aspects of machine design *Int. Anesthesiol. Clinics* **25** (3) 137–53
- Shymada Y and Yoshida I 1984 Effects of multiple scattering and peripheral circulation on arterial oxygen saturation measured with a pulse-type oximeter *Med. Biol. Eng. Comput.* **22** 475–8
- Steinke J M and Shepherd A P 1986 Role of light scattering in whole blood oximetry *IEEE Trans. Biomed. Eng.* **33** 294–301
- Twersky V 1962 Multiple scattering of waves and optical phenomena *J. Opt. Soc. Am.* **52** 145–71
- Twersky V 1970a Interface effects in multiple scattering by large, low refracting, absorbing particles *J. Opt. Soc. Am.* **60** 908–14
- Twersky V 1970b Absorption and multiple scattering by biological suspensions *J. Opt. Soc. Am.* **60** 1084–93
- Wukitsch M W, Petterson M T, Tobler D R and Pologe J A 1988 Pulse oximetry: analysis of theory, technology, and practice *J. Clin. Monitoring* **4** 290–301
- Zijlstra W G, Buursma A and Meeuwse-van der Roest W P 1991 Absorption spectra of fetal and adult oxyhemoglobin, de-oxyhemoglobin, carboxyhemoglobin, and methemoglobin *Clin. Chem.* **37** 1633–8

## INSTRUCTIONAL OBJECTIVES

- 4.1 Describe the properties and limitations of Beer's law.
- 4.2 Describe different species of hemoglobin and their effect on the oxygenation of blood.
- 4.3 Describe the functional and the fractional hemoglobin saturation and their difference.
- 4.4 Describe the properties and assumptions of the spectrophotometric method to determine oxygen saturation in hemoglobin solutions.
- 4.5 Describe the principles of pulse oximetry and what a pulse oximeter measures.
- 4.6 Describe why and how a pulse oximeter measures the absorbance in the arterial blood only.
- 4.7 Describe the normalization of the signals and the reasons for this normalization.
- 4.8 Explain how and why the ratio of the normalized signals is calculated.
- 4.9 Explain errors in the spectrophotometric method when used for whole blood samples.
- 4.10 Describe the different physical phenomena occurring when light travels through tissue and blood.
- 4.11 Describe what light scattering is and where it occurs in pulse oximetry.
- 4.12 Describe the influence of light scattering on the accuracy of a pulse oximeter.



# LIGHT-EMITTING DIODES AND THEIR CONTROL

*Brad W J Bourgeois*

In order to make pulse oximetry practical in the modern medical environment, a light source is required that is powerful enough to penetrate more than a centimeter of tissue yet diminutive enough to fit in a small probe. Chapter 4 shows that it also is desirable for the light source at each desired wavelength to have a very narrow *emission spectrum*, which minimizes error in the measurement of arterial oxygen saturation ( $S_aO_2$ ). Fortunately, light-emitting diodes (LEDs) fulfill all the requirements for the light source in a pulse oximeter.

However, LEDs are not without drawbacks. The primary problem faced by pulse oximeter designers is how to deal with variations and shifts in the *peak wavelength* of each LED. Because the main function of a pulse oximeter, measuring arterial oxygen saturation, is so heavily dependent upon accurate values for the two wavelengths of light, a design which does all it can to compensate for LED wavelength changes will outperform its competition.

This chapter discusses important characteristics of LEDs, a LED driver circuit in a pulse oximeter, and various problems with the use of LEDs in pulse oximetry.

### 5.1 AN INTRODUCTION TO LIGHT-EMITTING DIODES

Light-emitting diodes are the light source of choice for all pulse oximeters on the market today. Their small size, excellent drive characteristics, and large light output over a very narrow bandwidth make them the ideal choice for the source of light at both the red and infrared wavelengths used in pulse oximetry.

The fact that LEDs are available for use in pulse oximetry is due to a combination of science and luck. LEDs are only available over an approximately 700 nm range of wavelengths, from blue in the visible spectrum into the near infrared. By contrast, the electromagnetic spectrum extends over a range of  $10^{14}$ . Another fortuitous fact is that the window of low absorption on the hemoglobin extinction curves occurs within the range of LED availability. The common LED wavelengths of 660 and 940 nm work very well in pulse oximetry, which allows for lower cost due to the off-the-shelf availability of these LEDs.

### 5.1.1 Description, materials, and operation

An LED is an optoelectronic semiconductor which produces light by *electroluminescence* (D.A.T.A. Handbook 1992). LEDs are characterized by high light emitting efficiency compared to other methods of light emission such as cathode, high-temperature, and photoluminescence. The electroluminescence occurs by the injection and recombination of minority carriers in the forward-biased  $p$ - $n$  junction. Most LEDs are made from III-V, II-VI, and IV semiconductors, with the most common materials being gallium arsenide phosphide (GaAsP), gallium phosphide (GaP), and gallium arsenide (GaAs). GaAsP and GaP LEDs emit light in the visible spectrum (approximately 380 to 780 nm), while GaAs is used in infrared LEDs. Another material not as commonly used to make LEDs which can produce light in both the visible and IR regions of the spectrum is gallium aluminum arsenide, GaAlAs.

Figure 5.1 shows the light emission mechanism of an LED. When an electron gains enough energy to cross the forbidden energy gap  $E_g$ , it enters the conduction band. When an electron in this conduction band returns to the lower energy level of the valence band, the electron releases energy in the form of a photon of light. The wavelength of light emitted from an LED is determined by

$$E_g = hc/\lambda, \quad (5.1)$$

where  $E_g$  is the forbidden bandwidth in electron volts,  $h$  is Planck's constant ( $6.626 \times 10^{-34}$  J s),  $c$  is the speed of light in a vacuum ( $3.00 \times 10^8$  m/s), and  $\lambda$  is the wavelength of the emitted photon. The value of  $E_g$ , which is a physical property of the LED material(s), determines the wavelength of emitted photons and is directly related to the forward voltage of an LED (see section 5.2.1).

### 5.1.2 Bandwidth considerations

Another factor considered in the use of LEDs in pulse oximetry is the emission spectrum of the LED. Because of the steep slope of the deoxyhemoglobin (Hb) extinction curve at 660 nm, it is extremely important that the red LEDs used in pulse oximeter probes emit a very narrow range of wavelengths centered at the desired 660 nm in order to minimize error in the  $S_pO_2$  reading, which is the pulse oximeter's estimation of arterial oxygen saturation (New and Corenman 1987, 1988). The width of the wavelength range of the IR LED is not as important for accuracy due to the relative flatness of both the Hb and HbO<sub>2</sub> (oxyhemoglobin) extinction curves at 940 nm. LEDs again perform very well for this requirement. Typical LEDs have a *spectral bandwidth* in the range of 60 nm to less than 20 nm, with visible LEDs usually having smaller bandwidths of approximately 25 nm and IR LEDs typically having larger bandwidths near 50 nm.

## 5.2 LIGHT-EMITTING DIODE SPECIFICATIONS

Before discussing the specifications of LEDs available on the market, the performance desirable for LEDs in pulse oximetry will be given. The two predominant factors are the radiated power (or light output) and the size of the LEDs.

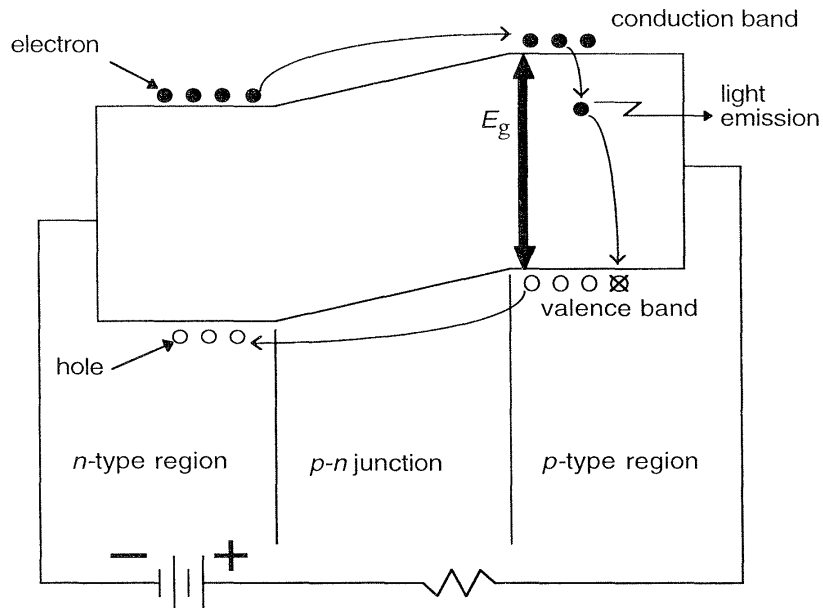

**Figure 5.1** The light emission mechanism of an LED. Electrons gain energy moving to the conduction band. They emit light when dropping to the valence band.

The radiated power of an LED is measured in milliwatts. The typical radiated power of both the red and IR LEDs used in pulse oximetry is 1 mW at 20 mA dc. Brighter LEDs are available, but generally the radiated power does not exceed 10 mW.

Modern manufacturing techniques have shrunk LEDs to sizes smaller than a millimeter in length or diameter, while remaining bright enough to be used in devices such as pulse oximeters. LED size is not an obstacle in the design of pulse oximeter probes.

### 5.2.1 Forward voltage

The forward voltage is defined as the potential drop across the  $p$ - $n$  junction of the diode from anode to cathode. While ordinary silicon diode forward voltages are near 0.7 V, LEDs forward voltages can range from 0.9 to 2.5 V typically. Equation (5.1) shows that an inverse relationship exists between a material's forbidden energy gap  $E_g$  and the wavelength of emitted photons. In addition, the forward voltage of an LED is directly related to  $E_g$ . Therefore, an LED with a relatively small forward voltage has a small  $E_g$  and a long emitted wavelength (e.g. in the infrared region). Conversely, an LED with a relatively large forward voltage has a large  $E_g$  and a short emitted wavelength (e.g. in the blue-green region).

### 5.2.2 Forward current

The forward current is defined as the current flowing through the LED in the direction from anode to cathode. With sufficient current, an LED will emit light. A very important property of LEDs is that radiated power, to a first

approximation, varies linearly with forward current over the range of current found in pulse oximeters. Typical values for forward current have a large range, from 2 to 50 mA. Figure 5.2 shows the relationship between current and voltage for a typical 660 nm LED.

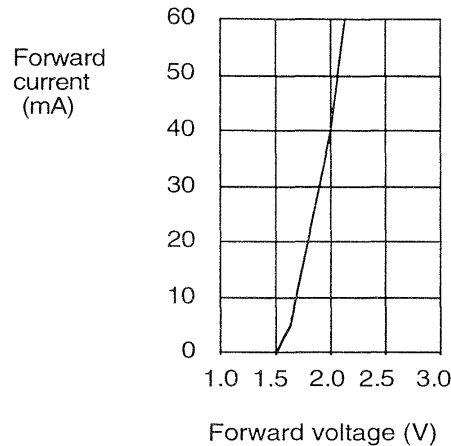

Figure 5.2 Forward current–voltage characteristic for a typical 660 nm GaP LED.

### 5.2.3 Power dissipation

Another consideration for LEDs used in pulse oximetry is power consumption. While the vast majority of pulse oximeters are used in a stationary environment where power is readily available from the nearest wall outlet, some are portable units used in a variety of emergency medical situations. These portable units may need to function for an extended period of time without a power supply recharge. It is therefore essential that LED power consumption be minimized while still providing adequate radiated power for pulse oximetry.

The maximum power dissipation rating for an LED can be defined as the largest amount of power that can be dissipated while still remaining within safe operating conditions. This power is a function of three parameters: ambient temperature, rated maximum junction temperature, and the increase in junction temperature above ambient per unit of power dissipation for the given LED’s package and mounting configuration. The latter of these parameters is defined as the *thermal resistance* of the device, and is very important in reliable system design. The worst-case value for thermal resistance, that with no heat sink, can be calculated from

$$R_{TH} = (T_J - T_A)/P_D \text{ } ^\circ\text{C/W}, \tag{5.2}$$

where  $R_{TH}$  is the thermal resistance,  $T_J$  is the junction temperature,  $T_A$  is the ambient temperature, and  $P_D$  is the rated power dissipation of the LED. Another method for calculating thermal resistance is to use the negative reciprocal of the slope of the forward current versus ambient temperature graph, figure 5.3. This value is in units of  $^\circ\text{C}/\text{mA}$ , which can be converted to the thermal resistance in  $^\circ\text{C}/\text{W}$  by multiplying the denominator by the LED forward voltage (D.A.T.A.

Handbook 1992). Because the skin is the primary sink for LED heat in pulse oximetry, the design engineer must consider power dissipation in order to prevent possible burns to the patient's skin.

Typical LEDs are 2 to 10% efficient, meaning that the majority of power dissipated by an LED becomes heat. The optical power absorbed by the tissue also becomes heat. As with forward current, a broad range of power ratings is available, typically from 20 to 300 mW. An interesting fact to note is that the typical IR LED, with its lower forward voltage (see section 5.2.1), required a greater forward current to dissipate the same optical power as a typical red LED. This is because red photons contain more energy than infrared photons.

#### *5.2.4 Reverse breakdown voltage*

As with all diodes, under reverse bias virtually no current will flow across the  $p$ - $n$  junction until the reverse breakdown voltage has been reached. Above that voltage, large currents flow and damage the diode, unless a resistor limits the current. Most LEDs have a fairly small value for this specification, usually in the range of 3 to 5 V. This specification is important in pulse oximetry due to the arrangement of the LEDs in a probe. To minimize the number of wires in each probe (and hence cost), the LEDs are wired in a parallel arrangement with polarities reversed. This means that while one LED is ON, the other LED is under reverse bias. The typical LED has a reverse breakdown voltage that is larger than the forward voltage of most LEDs, minimizing the difficulty in dealing with this specification.

#### *5.2.5 Reverse current*

In an ideal diode, no current flows in the reverse direction when the  $p$ - $n$  junction is reverse-biased. In reality, a minute amount of current actually does flow in the reverse direction. In LEDs, this current typically ranges from 0.01 to 10  $\mu$ A. Since this current is extremely small compared to the forward current of the LED wired in parallel, this shunt current has a negligible effect.

#### *5.2.6 Operating temperature*

Pulse oximeters are usually used in a stable medical environment at room temperature. However, emergency situations may arise in which a pulse oximeter has to operate under extreme temperatures. Fortunately, LEDs are extremely rugged devices with a basic specified range of operating temperature from  $-40$  to  $85$  °C. Many LEDs with an even larger operating temperature range are available.

Most LED parameters are specified at a given temperature. In addition, information is given for how some of these parameters vary over a given temperature range (see section 5.5). The most important of these parameters is maximum forward current versus temperature, which determines the thermal resistance of the LED (see section 5.2.3). Figure 5.3 shows the relationship between maximum forward current and temperature for a typical high-power 660 nm red LED.

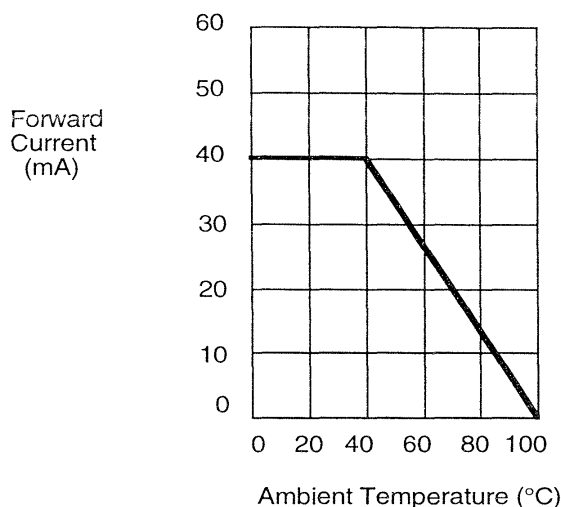

**Figure 5.3** Maximum forward current versus temperature for a typical high-power red LED.

### 5.2.7 Switching times

*Switching time* is the time required for an LED to switch from its ON state to its OFF state or vice versa. Most LEDs have a switching time in the low hundreds of nanoseconds. In the application of pulse oximetry, this is much faster than required because of the extremely low frequency of the arterial pulsatile waveform (~1 Hz). For reasons which will be explained in chapter 8, in most pulse oximeters LED switching cycles occur at a rate of 480 Hz, much more slowly than the maximum switching capabilities of LEDs.

### 5.2.8 Beam angle

*Beam angle* is defined as the angular measure of radiated power measured on an axis from half-power point to half-power point. It is simply a measure of how focused the emitted light is. In LEDs on the market today, beam angles can range from a few degrees to a maximum of 180°. In pulse oximetry, the beam angle only needs to be narrow enough to ensure that the maximal light output enters the tissue. The scattering of light occurring in the tissue serves to ensure that the light spreads over the entire sensor area.

### 5.2.9 Pulse capability

*Pulse capability* is defined as the maximum allowable pulse current as a function of *duty cycle* and frequency. This parameter is important in pulse oximeters for two main reasons. The first reason is that, as discussed in chapter 8, LEDs are pulsed in pulse oximeters. The second reason is that the small LEDs used by some manufacturers in pulse oximeter probes may not be able to tolerate enough sustained current to sufficiently excite the photodiode. Since the allowable pulse current is always substantially higher than the maximum sustained current, smaller LEDs can be used than could be if the LEDs were constantly on. For

example, the LEDs in Criticare pulse oximeters have a duty cycle near 5%, while in Nellcor devices it is 25%. Figure 5.4 shows the pulse capability of a typical 660 nm LED.

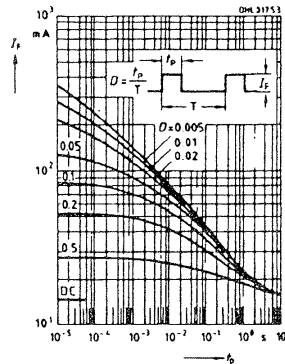

**Figure 5.4** Pulse capability of a typical high-power 660 nm LED. The maximal pulse current is a function of the duty cycle  $d$  and frequency (from Siemens 1993).

### 5.2.10 Cost

Chapter 7 states that a disposable probe for use in pulse oximetry has some advantages over reusable probes, such as convenience and guaranteed sterility. With the widespread use of disposable probes, cost is the prohibitive factor in their manufacture. The cost of the two LEDs used in each probe is therefore important for the purpose of minimizing the overall expense of each probe. Today, both red and IR LEDs can be purchased in bulk for just a few cents each, making them a minor factor in the overall cost of a probe. (Allied Electronics, Inc. 1995, Digi-Key Corporation 1995). However, testing each LED to find its peak wavelength, as discussed in the following section, does increase the overall cost to the manufacturer.

## 5.3 MEASURING AND IDENTIFYING LED WAVELENGTHS

Chapter 4 notes that the choice of 660 and 940 nm for the light wavelengths was not arbitrary with respect to optical considerations. Because of the steep slope of the Hb extinction curve at 660 nm, it is important that the red LEDs used in pulse oximeter probes have a peak wavelength of exactly 660 nm in order to minimize error in the  $S_pO_2$  reading (see chapter 11). Error in the peak wavelength of the IR LED is not as important for accuracy due to the relative flatness of both the Hb and HbO<sub>2</sub> extinction curves at 940 nm. An alternative to having LEDs with precise peak wavelengths of 660 and 940 nm is to have the pulse oximeter itself somehow compensate for any deviation from those nominal values. This section discusses these concerns.

As is the case with all mass manufacturing processes, imperfections occur in each lot of LEDs produced. For pulse oximetry, the most important of these is peak wavelength shift. Peak wavelength is defined as the wavelength at which the radiated power of the device is maximum. Although bulk LEDs theoretically all have the same peak wavelength, figure 5.5 shows that the actual peak wavelength of any LED may vary from the rated value by as much as 15 nm (Pologe 1987).

In order to solve this problem, pulse oximeters can compensate for a number of different LED peak wavelengths. This technique has the advantage of lowering cost by allowing probe manufacturers to buy and use LEDs in bulk instead of being able to use only LEDs with peak wavelengths of exactly 660 and 940 nm.

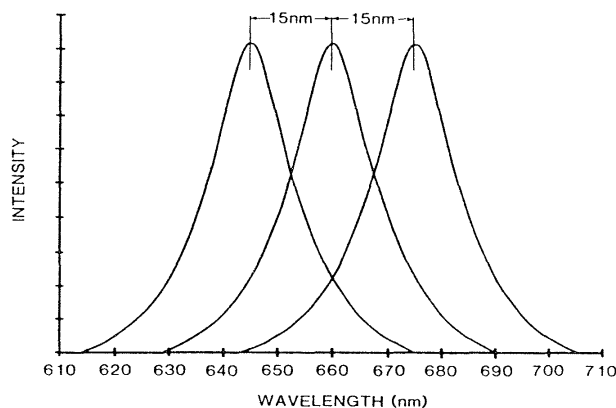

**Figure 5.5** Center wavelength variation of LEDs of the same type from the same lot (from Pologe 1987).

While many methods exist to solve this problem, only the one most commonly used in pulse oximeters will be explained here.

The first step in the process for the probe manufacturer is to test each individual LED to find its exact peak wavelength. This is done by testing each individual LED with a spectrophotometer to experimentally determine the wavelength of light at which the LED has its highest power output. The LEDs are then separated into a certain number of groups, with each group having a small, distinct range of wavelengths, for example 660 to 661 nm.

Knowing the center wavelengths for a particular LED pair allows the proper set of calibration curves, specific to that wavelength combination, to be chosen from the entire family of curves that exist. This is most often done by developing a two-dimensional matrix with, for example, the red LED wavelength values in the heading row and the IR LED wavelength values in the heading column. Each matrix location then identifies the appropriate set of calibration curves for the given pair of LEDs.

The final problem to be solved is to have the pulse oximeter somehow interrogate each new probe to find out which calibration curve must be used to accurately determine arterial oxygen saturation. The most common technique is to include in the probe connector a coding resistor with a specific value. Each unique resistor value represents to the pulse oximeter those pairings of LED wavelengths that correspond to one calibration curve. The microprocessor simply sends a current through the resistor and measures the voltage drop across it, in effect finding the value of the coding resistor. By finding this voltage value in a lookup table, the microprocessor can indirectly determine the proper calibration curve to be used for that probe (New and Corenman 1987, 1988).

Chapter 8 provides details of how the pulse oximeter performs this interrogation of each probe.

Kästle *et al* (1997) describes how Hewlett-Packard avoided using a coding resistor by selecting red LEDs within a  $\pm 1$  nm variation of wavelength. A later



sensor used new high-efficiency AlGaAs red LEDs to achieve a four-fold increase in intensity, with corresponding lowered heat dissipation. They also note that the red LED may emit an undesired secondary emission peak (<4% of maximum intensity) at about 800 to 850 nm, which may interfere with the IR LED. They place the LED in an integrating sphere to diffuse the light for wavelength measurement by an optical spectrometer having a wavelength resolution of 0.2 nm.

#### 5.4 LED DRIVER CIRCUIT

This section presents an overview of the operation of a specific LED driver circuit used in many pulse oximeters. Greater detail about the microprocessor control, signal processing, and other hardware or software concerns can be found in chapters 8 and 9.

Figure 5.6 shows the LED driver circuit. This circuit, and the LED driver circuits in many of the pulse oximeters on the market today, provide up to 50 mA of pulse current to each LED. The microprocessor automatically alters the amount of current supplied to the LEDs according to the absorption of the tissue on which the pulse oximeter is being used. Factors such as skin pigmentation, skin thickness, and optical path length, among many others, determine the absorption of the tissue. The microprocessor first determines if the photodiode is receiving a proper amount of light, enough to adequately excite but not saturate the photodiode. The microprocessor then supplies voltage feedback to the LED driver circuit, which allows current to the LEDs to be adjusted as needed. No complex calculations are necessary to determine current adjustments, as radiated power varies nearly linearly with drive current over the range of current utilized in pulse oximetry.

The microprocessor controls how much current is provided to each LED by dynamically adjusting the reference voltage seen at the driver amplifier, U3A. U1 supplies the reference voltage, which is switched selectively for the red and IR LEDs using U4A and U4B. The microprocessor changes the reference voltage for the red or IR LEDs by changing the data supplied to U1, which is a multiplying DAC, before the voltage is switched to the amplifier. The microprocessor attempts to achieve and keep the optimal drive current without clipping the transducer signal.

The control signals REDLED/ and IRLED/ come from the microprocessor and control the switches U4A and U4B along with the transistor network that drives the LEDs. The LEDs are never on at the same time, although during part of the LED switching cycle they are both off to allow the photodiode to detect ambient light.

When REDLED/ is low, IRLED/ is high and U4A is closed, placing the red reference voltage at pin 3 of U3A. Since REDLED/ is low, transistor Q5 is off, which allows Q3 to turn on and conduct current from the LED through R1, the sense resistor. Also with REDLED/ low, Q2 turns on, allowing current to flow from the positive supply to the red LED anode, turning on the red LED. Since IRLED/ is high, Q1 is off, with no current conduction, and Q6 is on, pulling the base of Q4 to ground, which keeps Q4 off. The current path in this case is from VCC through Q2, the red LED, Q3, and R1, the sense resistor. The voltage drop across R1 is fed back to U3A, which compares it to the reference voltage and changes the drive current of Q3 accordingly.



When REDLED/ is high, IRLED/ is low and the reference voltage is applied to U3A through U4B. Having REDLED/ high causes Q2 to be off and Q5 to be on, turning off Q3. Having IRLED/ low turns Q1 on, allowing current to flow to the IR LED anode, turning on the IR LED. Q6 is also turned off, which allows the base of Q4 to be pulled up in voltage by U3A until Q4 conducts. The current path in this case is from VCC through Q1, the IR LED, Q4, and R1. The voltage drop across R1 is again fed back to U3A, which compares it to the reference voltage and changes the drive current of Q4 accordingly.

In the case when both the IRLED/ and REDLED/ control signals are high, both switches, U4A and U4B, are open and all of the drive transistors are off. The resistors R2, R4, and R3 form a voltage divider network that makes the reference input of U3A slightly negative with respect to ground. Because of this, U3A drives its output negative. However, D1 will not allow U3A's output to drop below approximately  $-0.6$  V so that the drive transistors Q3 and Q4 can be turned on quickly when needed (Protocol 1994, pp 2E5–6).

## 5.5 LED PEAK WAVELENGTH SHIFT WITH TEMPERATURE

As discussed in section 5.3, pulse oximeter probe manufacturers could use any of a number of methods to compensate for LED peak wavelengths which vary from the nominal values of 660 and 940 nm, with the method of choice being the use of a coding resistor to indicate to the microprocessor which set of calibration curves to use for a given probe.

However, the peak wavelength of an LED can shift during operation due to a change of the  $p$ - $n$  junction temperature. It is more difficult to account for this wavelength shift when determining which set of calibration curves to use. The effect that LED peak wavelength shift due to temperature has upon  $S_pO_2$  will be discussed in detail in chapter 11. Lastly, two methods of minimizing the negative effects of temperature changes upon  $S_pO_2$  will be discussed.

### 5.5.1 $p$ - $n$ junction heating

Equation (5.1) shows that the wavelength of emitted light in an LED depends on the forbidden energy gap  $E_g$ . In turn,  $E_g$  is dependent upon temperature (Varshni 1967, Panish and Casey 1969). In GaAs, GaP, and most other common semiconductor materials,  $E_g$  decreases as temperature increases. Therefore, the peak wavelength of an LED should increase as the  $p$ - $n$  junction temperature increases. Typically, the peak wavelength will increase by 0.35 to 0.6 nm/°C (Miller and Kaminow 1988).

The main factor affecting the  $p$ - $n$  junction temperature of the two LEDs is drive current, which causes ohmic heating at the  $p$ - $n$  junction. Although the LEDs are sequentially pulsed with a duty cycle of 2 to 50% depending on the make of the oximeter (Reynolds *et al* 1991), the resulting average current (duty cycle multiplied by drive current) is still sufficient to substantially heat the  $p$ - $n$  junction, as power dissipated is directly proportional to the drive current  $I$  according to the equation  $P = VI$ .

### 5.5.2 Studies

de Kock *et al* (1991) tested the effect upon peak wavelength of driving a red and IR LED at 10% and 100% of the rated maximum drive current. The nominal

wavelengths of the tested LEDs were 660 and 950 nm, with 30 min allotted for thermal equilibrium to be reached. At 380 Hz with a 25% duty cycle, they found that the increased drive current increased the center wavelength of the red LED by 8 nm, while the center wavelength of the IR LED did not shift at all. Figures 5.7 and 5.8 show their results.

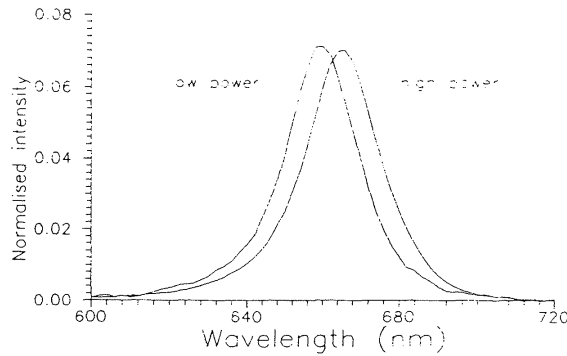

Figure 5.7 Normalized red LED spectra at low and high forward current (from de Kock *et al* 1991).

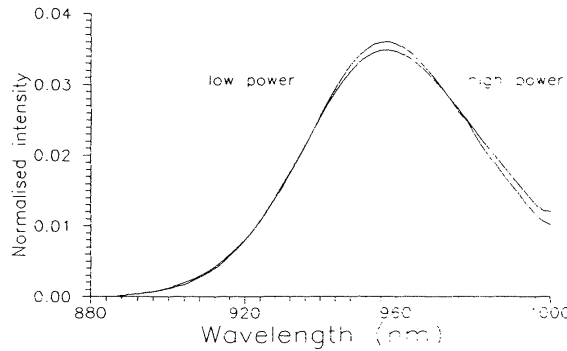
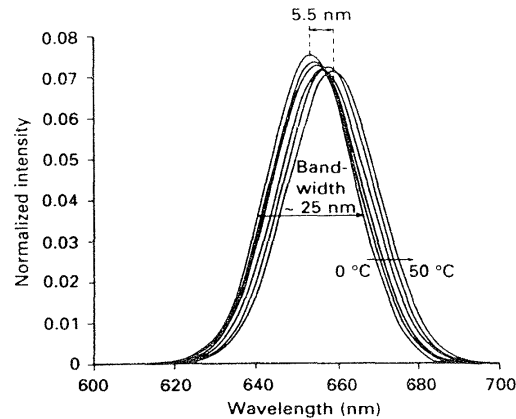

Figure 5.8 Normalized IR LED spectra at low and high forward current (from de Kock *et al* 1991).

The same group studied the effect of ambient temperature upon LED peak wavelength in 1991. As in the study mentioned above, the red and IR wavelengths were 660 and 950 nm. The spectrum of each LED was measured using a spectrophotometer at 2 nm intervals at ambient temperatures ranging from 0 to 50 °C in 10 °C steps. Ten minutes was given for thermal equilibrium to be established at each temperature step. The group found that over this range of ambient temperatures, the red LED had an increase of 5.5 nm in its peak wavelength, while the IR LED had an increase of 7.8 nm. In addition, no significant change was found in the spectral bandwidth of either LED over the temperature range. The measured bandwidths were found to be approximately 25 and 55 nm for the red and IR LEDs, respectively. Figures 5.9 and 5.10 show these results.

Kästle *et al* (1997) list a wavelength shift of about 0.12 nm/K but note that the red and IR LEDs tend to track temperatures, which compensates for errors in the ratio  $R$ .



**Figure 5.9** Shift in emission spectrum of a red LED as ambient temperature is increased from 0 to 50 °C in 10 °C intervals (from Reynolds *et al* 1991).

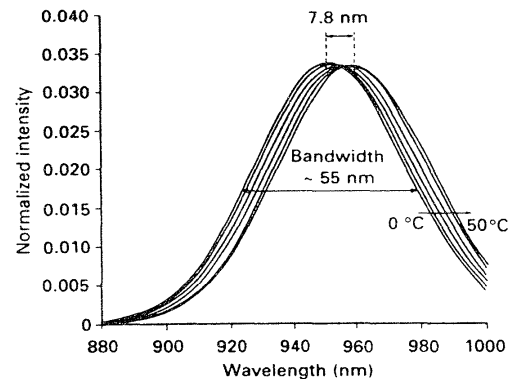

**Figure 5.10** Shift in emission spectrum of an IR LED as ambient temperature is increased from 0 to 50 °C in 10 °C intervals (from Reynolds *et al* 1991).

### 5.5.3 Two methods to compensate for LED temperature changes

As expected, a shift in LED peak wavelength due to a change in temperature can cause erroneous  $S_pO_2$  readings. A full discussion of this problem will be given in chapter 11.

One way to compensate for LED temperature changes is to have a temperature sensor built into the probe along with the LEDs and photodiode (Cheung *et al* 1993). Temperature information is fed back to the microprocessor, which then estimates how much the peak wavelength of each LED has changed from its rated value (which the microprocessor determined from the probe's coding resistor). The microprocessor then chooses the set of calibration curves to match the new set of LED wavelengths. One inherent problem with this method is that the temperature–peak wavelength relationship given as a specification by the manufacturer will not be exactly the same for each individual LED, making the microprocessor's calculation of new LED peak wavelengths potentially inaccurate. Another problem is the difference between the sensed temperature and the actual temperature of the  $p$ – $n$  junctions of the LEDs. If the two LEDs are being driven with different currents, as is normally the case, they will probably be at different temperatures. The temperature sensor will read at best an average

of the two LED temperatures, and at worst an average of the two LED temperatures along with the skin and ambient temperatures. In addition, the sensor and additional wires needed will add cost to the probes, making a cost-benefit analysis of this method necessary before its inclusion in a pulse oximeter design.

A second, similar method to compensate for LED temperature changes is to measure the LED drive current directly. The microprocessor would then use that drive current value to calculate the estimated temperature change, and from that, calculate the estimated peak wavelength shift. This method eliminates the second problem listed above for the temperature sensor solution, but still leaves the problem of variations in the relationship between temperature and peak wavelength among individual LEDs. Another advantage of this method is that no extra wires or other components need to be added to a probe, making this the less expensive of the two methods discussed here.

## 5.6 PREVENTION OF BURNS IN PULSE OXIMETRY

In order to prevent burns on a patient's skin due to LED heat, the Food and Drug Administration now requires that the contact region between the skin and the oximeter probe not exceed 41 °C. Given an average body temperature of 37 °C, a pulse oximeter system should be designed to yield a maximum temperature rise of 4 °C at the skin-probe contact region, which is the primary dissipator of the LED heat. The relevant LED specification is thermal resistance, discussed in section 5.2.3. In pulse oximetry, the thermal resistance of each LED is on the order of a standard LED mounted in a PC board, which is a specification given in LED product catalogs. As previously mentioned, many pulse oximeters on the market have a maximal LED pulse current of 50 mA. This is sufficiently small to prevent dangerous LED heating, while still providing adequate light to the photodiode.

Mills and Ralph (1992) tested the heating of six pulse oximeter probes over a span of 3 h. The probes were placed in an incubator kept at a constant temperature of 36.9 to 37 °C. The working temperatures of the probes were quite similar, with a range of 39.1 to 39.7 °C over the entire 3 h. One of the probes was monitored for 24 h, and during that time its temperature remained constant within a range of  $\pm 0.1$  °C.

The conditions of this test, however, did not do anything to simulate the reaction of skin to heating of a few degrees for several hours. To ensure that no burning occurs, the probe's point of application should be inspected often. In addition, the position of the probe on the patient should be changed regularly, especially if the probe application area suffers from low perfusion, which limits the skin's ability to dissipate heat.

## 5.7 LED PACKAGING

Most LED packages are made of resin, offering superior mechanical strength and the ability to withstand vibration and shock. In some of today's pulse oximeter probes, the two LEDs can be found in one package, which has the distinct advantage of keeping costs down. In the Nellcor SCP-10 reusable and Oxisensor II D-25 disposable pulse oximeter probes, the two LEDs come encased in a transparent rectangular solid with approximate dimensions of 5 mm long by 4

mm wide by 2 mm thick. The LEDs themselves are flat squares with sides of approximately 0.25 mm.

Other probes have discrete LEDs inside, with the LEDs lying side by side and a mirror to reflect light at a 90° angle to the tissue. Some probes even have three or four LEDs in them to increase light output. The details of these and many other probes will be discussed in Chapter 7.

There is no wrong choice for LED packaging as long as the LEDs are small yet powerful enough to perform the task at hand. However, there is definitely a superior choice for packaging when trying to minimize costs, and that choice is almost always a package containing both LEDs.

## REFERENCES

- Allied Electronics, Inc 1995 *Catalog 956* (Fort Worth, TX: Allied Electronics)
- Cheung P W, Gauglitz K F, Hunsaker S W, Prosser S J, Wagner D O and Smith R E 1993 Apparatus for the automatic calibration of signals employed in oximetry *US patent 5,259,381*
- D.A.T.A. Handbook 1992 *LED Lamps and Displays* (Englewood, CO: D.A.T.A)
- de Kock J P, Reynolds K J, Tarassenko L and Moyle J T B 1991 The effect of varying LED intensity on pulse oximeter accuracy *J. Med. Eng. Technol.* **15** (3) 111–6
- Digi-Key Corporation 1995 *Catalog No. 956* (Thief River Falls, MN: Digi-Key)
- Kästle S, Noller F, Falk S, Bukta A, Mayer E and Miller D 1997 A new family of sensors for pulse oximetry *Hewlett-Packard J.* **48** (1) 39–53
- Miller S E and Kaminow I P 1988 *Optical Fibre Telecommunications Vol II* (New York: Academic) pp 487–8
- Mills G H and Ralph S J 1992 Burns due to pulse oximetry *Anaesthesia* **47** 276–7
- New W Jr and Corenman J E 1987 Calibrated optical oximeter probe *US patent 4,700,708*
- New W Jr and Corenman J E 1988 Calibrated optical oximeter probe *US patent 4,770,179*
- Panish M B and Casey H C Jr 1969 Temperature dependence of the energy gap in GaAs and GaP *J. Appl. Phys.* **40** 163–7
- Pologe J A 1987 Pulse oximetry: technical aspects of machine design *Int. Anesthesiol. Clinics* **25** (3) 137–53
- Protocol 1994 Propaq® 100–Series Monitors *Schematics & Drawings Set* (Beaverton OR: Protocol Systems)
- Reynolds K J, de Kock J P, Tarassenko L and Moyle J T B 1991 Temperature dependence of LED and its theoretical effect on pulse oximetry *Br. J. Anaesthesia* **67** 638–43
- Siemens 1993 *Optoelectronics Data Book* (Cupertino CA: Siemens)
- Varshni Y P 1967 Temperature dependence of the energy gap in semiconductors *Physica* **34** 149–54

## INSTRUCTIONAL OBJECTIVES

- 5.1 Sketch a current–voltage curve for an LED and indicate the approximate maximal current to prevent damage to the LED.
- 5.2 State the maximal LED current that will not cause burns to the patient.
- 5.3 Sketch and describe the current control system for LEDs in a pulse oximeter.
- 5.4 Describe how a pulse oximeter determines the LED wavelengths in a given probe.
- 5.5 Explain the process by which an LED emits light. Relate the explanation to the main point of interest on an LED I–V plot.
- 5.6 Discuss bandwidth characteristics of red and IR LEDs, including temperature and drive current effects.
- 5.7 Explain how a change in LED drive current indirectly affects the output spectra of red and IR LEDs.
- 5.8 Explain how a change in LED temperature affects the output spectra of red and IR LEDs.
- 5.9 Discuss two techniques which would automatically compensate for a shift in the peak wavelength of the LEDs.
- 5.10 Give reasons why LEDs are convenient to use in pulse oximetry.

## CHAPTER 6

---

# PHOTODETECTORS AND AMPLIFIERS

*Jeffrey S Schowalter*

The photodetector is the main input device of the pulse oximeter system. These devices, found in the probe, sense the intensity of light emitted by each LED after the light passes through the tissue. The photodetector produces a current which is linearly proportional to the intensity of incident light. This current is then converted to a voltage which is passed on to the pulse oximeter unit for processing. The choice of photodetector depends on factors such as performance, packaging, size, and cost. However, most pulse oximeters currently use silicon photodiodes. Transimpedance amplifiers, which convert the photodiode current to a voltage are also discussed.

### 6.1 PHOTODETECTION DEVICES

A variety of devices can be used to sense the intensity of a light source. These include photocells, photodiodes, phototransistors, and integrated circuit (IC) sensors. When choosing a photodetection sensor, several things need to be considered. First, since the pulse oximeter uses two specific wavelengths, *spectral response*, or the relative response of the device to different wavelengths must be considered. Another important consideration is the linearity of the output signal. With the pulse oximeter, an output linearly proportional to the intensity of incident light, also known as *illumination* ( $E$ ), is highly desirable. A third important factor is *sensitivity*, or the ratio of the electrical output signal to the intensity of incident light. A related consideration is the response time, or how quickly the output of the device is able to respond to a change in the incident light. Size also becomes a consideration since many of these devices are mounted in disposable probes (as will be discussed in chapter 7). Finally, as is the case with any commercial device, the cost must be considered. Each type of device merits consideration although the photodiode is most frequently chosen for pulse oximeter applications.

#### 6.1.1 Photocells

A *photocell* exhibits a change in resistance that is proportional to light intensity. In these semiconductor devices, also referred to as *photoconductors* and *photoresistors*, the electrical conductivity of the material is dependent on the



number of carriers in the conduction band. Incident light increases the number of carriers generated and thus increases the conductivity. These devices have spectral responses dependent on the type(s) of materials used in their manufacture. In the visible/near infrared range (400 to 1400 nm), which includes the wavelengths used in pulse oximetry, the most common materials used are cadmium sulfide (CdS) and cadmium selenide (CdSe). Equation (6.1) shows the relationship between the resistance of a photocell and the illumination  $E$ :

$$R = AE^{-\alpha} \quad (6.1)$$

where  $R$  is the resistance of the device and  $A$  and  $\alpha$  are constants dependent on manufacturing process and material type (Pallas-Areny and Webster 1991). This equation shows that the relationship between resistance and light intensity is highly nonlinear. In addition, the resistance changes quite dramatically as a function of light intensity. For example, a typical CdS photocell can have its resistance change by a factor of  $10^4$  between an illuminated condition and a dark condition. Photocells are also temperature sensitive, exhibiting a changing resistance/incident light relationship with temperature. Increased temperature also causes increased thermal noise. The response time of the photocell is relatively slow. Time constants are on the order of 100 ms and these devices exhibit light memory, making their response dependent on the previous light level. In addition, photocells are relatively large in size with typical diameters of 5 to 25 mm (Vig 1986). Photocells are widely used and are relatively inexpensive (~\$1), but are not typically used in pulse oximetry applications.

### 6.1.2 Photodiodes

A photodiode produces an output current or voltage which is proportional to the intensity of the incident light. The  $p$ - $n$  junction photodiode consists of one layer of  $n$ -type semiconductor material along side a layer of  $p$ -type semiconductor material (see figure 6.1). When a photon is absorbed, it creates an electron-hole pair. Electrons from the  $p$ -side will move across the depletion region toward the  $n$ -side and holes from the  $n$ -side will be transported to the  $p$ -side. As a result, an electric current is generated.

Figure 6.2 shows a simple model for the photodiode. It is made up of the parallel combination of a current source, an ideal diode, and a junction capacitance.

For this photodiode the total current supplied ( $I$ ) can be expressed as

$$I = I_P - I_D \quad (6.2)$$

where the photocurrent  $I_P$  can be expressed as

$$I_P = SE \quad (6.3)$$

and the diode current  $I_D$  is expressed as

$$I_D = I_0 \left[ \exp\left(\frac{qV}{kT}\right) - 1 \right] \quad (6.4)$$

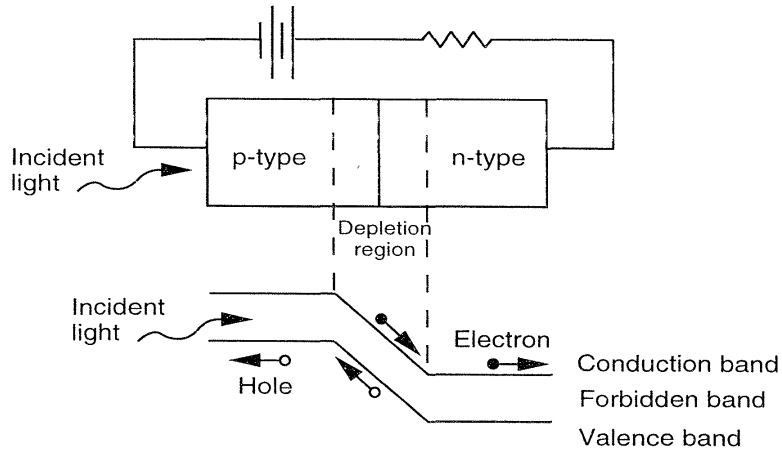

**Figure 6.1** *p-n* junction of a photodiode. Electrons move towards the *n* layer and holes move towards the *p* layer (adapted from Hitachi 1992).

where *S* is the *sensitivity* or the unit of photocurrent produced per unit of input light, *E* is the illumination, *I*<sub>0</sub> is the inverse saturation current, *V* is the voltage applied to the diode, *k* is Boltzmann’s constant, and *T* is absolute temperature.

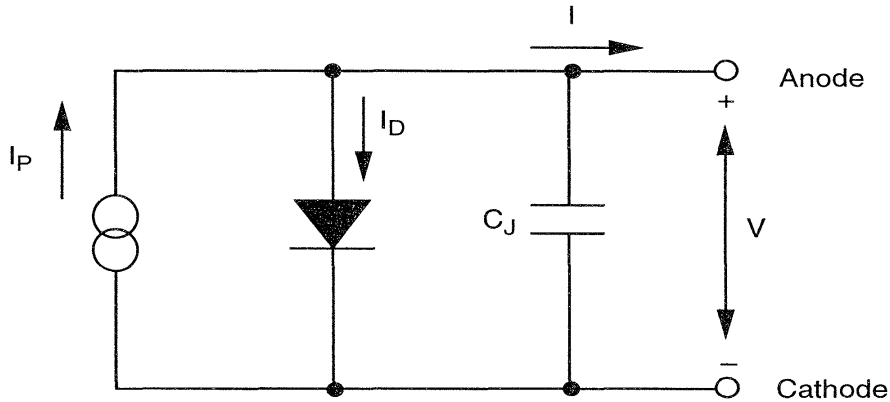

**Figure 6.2** Simplified photodiode equivalent circuit model. The current induced by the incident light is denoted by *I*<sub>*P*</sub>.

The photodiode operates in one of two modes. The photovoltaic operating mode generates a light induced voltage produced by an open-circuit photodiode. This output voltage however is not a linear function of incident light. In the open-circuit condition (*I* = 0), the output voltage is given by

$$V_{oc} = \frac{kT}{q} \ln\left(\frac{I_P}{I_D} + 1\right). \tag{6.5}$$

The photoconductive operating mode generates a light-induced current produced by a photodiode connected so that the photodiode voltage is zero or constant with varying light intensity. In this mode, output current is linearly proportional to the level of incident light. In the short-circuit condition (*V* = 0), the output current is given by

$$I_{sc} = SE. \quad (6.6)$$

Figure 6.3 shows the current versus voltage characteristics of a photodiode for various levels of incident light.

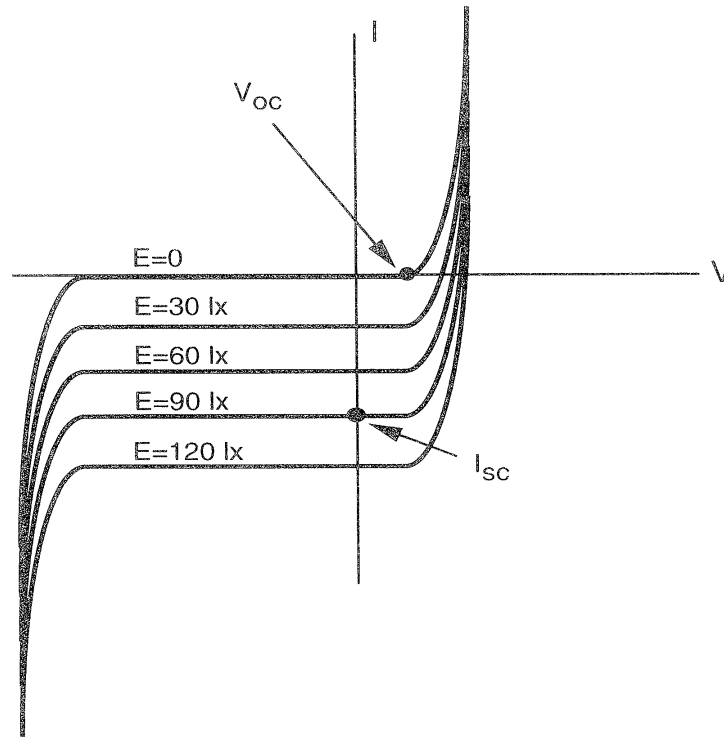

**Figure 6.3** Current versus voltage characteristics for a photodiode. For an open circuit condition ( $I = 0$ ), increasing light intensity results in a logarithmic increase in voltage. For a short circuit condition ( $V = 0$ ), the photodiode's current varies linearly with increasing incident light intensity.

When the  $p-n$  photodiode is used in the photoconductive mode, a highly linear relationship exists between the incident light level and the output current. The sensitivity of a typical photodiode varies by only 0.05% over most of its range (which may span up to seven decades) but can increase to several percent at high levels of incident light/output current. Sensitivity, however, varies significantly with incident light wavelength (see figure 6.4). The spectral response is determined by the material used for fabrication and the physical depth of the  $p-n$  junction. The silicon photodiode, shown in figure 6.4, works well with the wavelengths of interest to pulse oximetry. Photodiodes, when used in the photoconductive mode, are also relatively insensitive to temperature variations with the typical sensitivity varying by approximately +0.2%/°C. These devices have response times much faster than that of the photocell with typical values running on the order of 20  $\mu$ s. With radiant sensitive areas on the order of 1 to 7  $\text{mm}^2$ , silicon photodiodes' prices are equivalent to photocells (~\$1).

There are several different variants of the basic  $p-n$  photodiode. These include the  $p-i-n$  photodiode, the Schottky photodiode, the metal-semiconductor-metal photodetector and the avalanche photodiode. Of these, the  $p-i-n$  photodiode is frequently found in pulse oximetry applications.

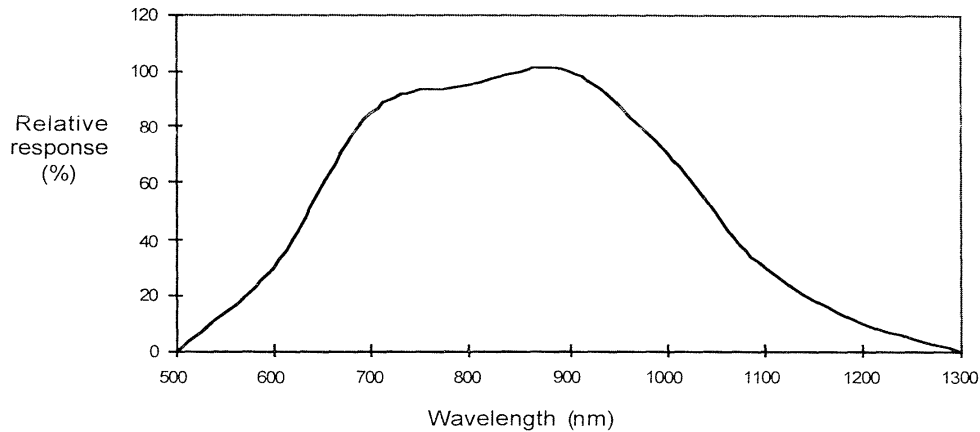

**Figure 6.4** Spectral response of a Si photodiode as a function of wavelength.

**6.1.2.1 *p-i-n* photodiodes.** The *p-i-n* photodiode has an intrinsic (lightly doped) layer between the *n* and *p* layers. This modified structure typically results in lower junction capacitance than for *p-n* diodes of the same optical sensing area. As a result, *p-i-n* photodiode response times are faster than *p-n* junction photodiodes. Bandwidths typically run on the order of 10 MHz for these devices. Since cost and size are comparable to the *p-n* photodiode, these devices are also used in pulse oximetry applications.

**6.1.2.2 *Shottky* photodiodes.** In these devices, a thin metal layer deposited on a semiconductor can form a Shottky barrier and if thin enough can pass incident light. These devices are primarily used to detect ultraviolet (UV) light and have smaller junction capacitances than either *p-n* or *p-i-n* photodiodes. This results in lower response times with frequency responses exceeding 100 GHz (Sloan 1994), far exceeding the requirements of the typical pulse oximeter application. However, with a primary spectral response in the UV range, these devices are not suitable for pulse oximetry applications.

**6.1.2.3 *Metal-semiconductor-metal (MSM)* photodetectors.** These devices commonly use interdigitated metal fingers to form the two electrical contacts of the device. They have low capacitance because of a small active area and a relatively fast response time. These devices have lower sensitivity than *p-i-n* photodiodes due to large amounts of surface covered by metal and as such are not currently being used for pulse oximeter applications.

**6.1.2.4 *Avalanche photodetectors (APDs)*.** Avalanche photodetectors are high speed photodetectors that make use of the avalanche multiplication effect of photons. APDs operate under large reverse bias voltage so the electric field is large. However, the multiplication effects result in increased noise, reduced bandwidth, avalanche buildup time (which slows response time), and noise multiplication. They are typically used as amplifiers for applications requiring detection of extremely low levels of light (Fraden 1997).

### 6.1.3 Phototransistors

A phototransistor can be thought of as a photodiode with a built-in current amplifier. Phototransistors typically have 100 to 500 times the sensitivity of a corresponding photodiode. In these devices, incident light on the base of the transistor induces a current. This current is then amplified by the transistor resulting in a significant increase in collector current. The sensitivity of these devices is not as linear as photodiodes with the sensitivity varying 10 to 20% over the useful range of the phototransistor (Siemens 1993). These devices do not have the light memory problems associated with photocells but sensitivity can vary as much as 50% among devices of the same type because of process and beta variations (Sprague Electric 1987). The response time for the typical phototransistor is 125  $\mu$ s. Size, cost and signal-to-noise ratio (SNR) of a phototransistor are equivalent to that of a photodiode. Although early pulse oximeters used phototransistors (Schibli *et al* 1978), currently photodiodes are the sensor of choice in pulse oximetry applications.

### 6.1.4 Integrated circuit (IC) sensors

Integrated circuit sensors are becoming increasingly popular for sensing incident light levels. These devices incorporated the features of a photodiode along with a current-to-voltage converter so that the output is a voltage which is a direct function of the incident light. Since photodiodes and IC amplifiers are built out of semiconductor material, IC designers have been able to fabricate both the hybrid circuitry and the photodiode on the same silicon substrate. Combining these two devices onto one chip eliminates problems commonly encountered in discrete designs such as leakage current errors, noise pick-up, and gain peaking due to stray capacitances (Burr-Brown 1994a,b,c). These devices typically are four times as costly as equivalent photodiodes and as such do not appear to have gained much acceptance by pulse oximeter manufacturers. However, at least one manufacturer (Protocol Systems 1992) is using this integrated circuit photodiode/transimpedance amplifier configuration.

## 6.2 PHOTODIODE CHARACTERISTICS

Because of their relatively low cost and linear output current response to incident light, both the standard  $p-n$  diodes and  $p-i-n$  (New and Corenman 1987) diodes are currently in use today as the photodetectors of choice for use in pulse oximetry systems. The following sections describe several key parameters related to photodiode operation. These parameters serve as evaluation criteria for the designer when selecting a photodiode for use in a pulse oximeter.

### 6.2.1 Junction capacitance

Photodiode junction capacitance is an important parameter and is proportional to the junction area. It also decreases with increasing reverse bias voltage so it may be expressed at a specified reverse bias voltage across the photodiode. The response speed of the photodiode depends on the  $RC$  time constant of the junction capacitance and the load resistance. Therefore a higher response speed can be obtained by applying a larger reverse bias voltage to the photodiode. It should be

noted however, that this technique is not typically used in pulse oximetry applications.

### 6.2.2 Dark current

Dark current is the reverse leakage current that flows in a photodiode in the absence of light. Dark current is usually specified at some specified reverse bias voltage or with zero voltage bias. Although technically, no dark current should flow with zero bias, most zero bias applications have a small voltage across the photodiode such as the offset voltage of the op amp. The dark current increases as the reverse voltage or ambient temperature increases.

### 6.2.3 Sensitivity

Since the output current of the photodiode is linear, the sensitivity is normally expressed as the output current level for a known incident light level at a specified temperature. The light source used to produce this specification varies among photodiode manufacturers though and can cause some confusion. In some cases, the sensitivity is determined with an LED optical source and thus the center frequency of the LED is specified. In this case incident light is expressed in  $\text{mW}/\text{cm}^2$ . If the light source is an International Commission on Illumination (CIE) standard light source (normally a tungsten lamp), it is expressed in lux (lx).

### 6.2.4 Spectral response

Figure 6.4 shows that photodiodes have a spectral response and as such care should be taken when selecting a photodiode. Normally photodiode manufacturers specify the spectral response by providing the wavelength of peak sensitivity. The designer should keep in mind the wavelengths of interest in pulse oximetry (660 nm and 940 nm) when deciding on an appropriate photodiode.

### 6.2.5 Packaging

Photodiodes used in pulse oximeter probes have some unusual mounting and mechanical assembly requirements. A variety of characteristics should be considered including cost, hermetic seal, package material and package type. In general, photodiodes are available in three types of packages: the can package, the ceramic stem package and the resin mold package.

**6.2.5.1 Can package.** In the can package (figure 6.5(a)), the photodiode chip is mounted on a metallic stem and is sealed with a cap that has a window to allow incident light to reach the semiconductor surface.

**6.2.5.2 Ceramic stem package.** With the ceramic stem package, the photodiode chip is mounted on a ceramic stem (figure 6.5(b)) and is coated with resin.

**6.2.5.3 Resin mold package.** For the resin mold package (figure 6.5(c)), the photodiode chip is mounted on a lead frame and molded with resin. Some of these devices use molding that is transparent only to certain wavelengths of light,

thereby limiting the wavelength sensitivity of the photodiode. This is the most common package type used in pulse oximetry today.

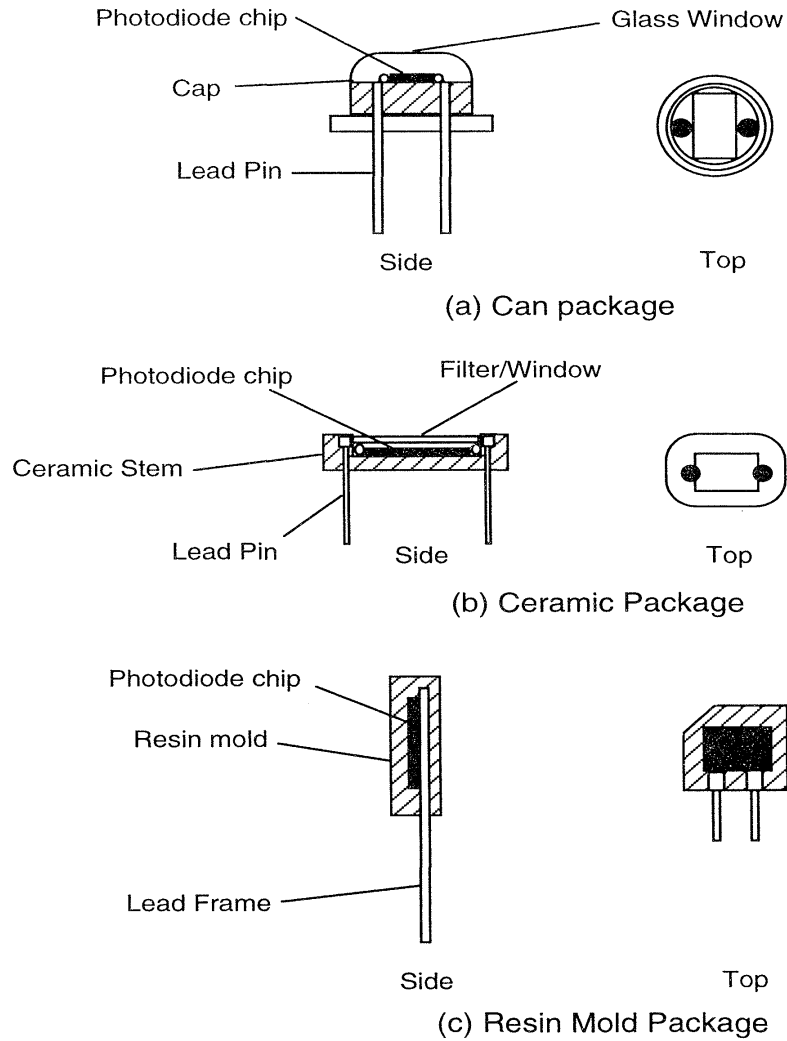

**Figure 6.5** Typical photodiode packaging (adapted from Sharp 1988).

Table 6.1 shows the characteristics for several typical photodiodes.

**Table 6.1** Electro-optic characteristics of two *p-i-n* photodiodes.

	Sharp PD4663PS	TRW OP913
Output current	120 nA @ 1000 lx	55 mA @ 5.0 mW/cm <sup>2</sup>
Dark current	200 pA	25 nA
Peak sensitivity wavelength	840 nm	875 nm
Junction capacitance	2 pF	150 pF

### 6.3 OPTICAL CONCERNS

Since this is a system with an optical interface, it is important to minimize the effects from light other than the optical signals of interest. One way to minimize unwanted light incident upon the detector is to place some type of light filter over the detector. This allows light of wavelengths of interest to pass through the filter but does not allow light of other wavelengths to pass through the filter. For the pulse oximeter to work effectively, most of the light being transmitted from the LEDs must not reach the photodiode unless it has passed through tissue containing arterial blood.

#### 6.3.1 Optical filtering

Optical filtering, placed between sources of light and the photodiode, is used to limit the spectral response of the photodiode. A number of optical filter types can be used. Cheung *et al* (1993) recommend a red Kodak No. 29 wratten gel filter to eliminate the flickering effect of fluorescent light. However, these external filters do not appear to be used much in actual pulse oximetry designs. In addition, the photodiode mounting package may contain filtering material. Many photodiodes are mounted in clear plastic which absorbs UV wavelengths (Burr-Brown 1994a,b,c). This is useful to filter out some of the unwanted effects of fluorescent lighting on the photodiode. Many photodiodes are available in a variety of packaging types each of which filters out selected wavelengths of light.

#### 6.3.2 Optical interference

To minimize errors, the pulse oximeter designer must attempt to limit the light reaching the photodiode to that which has traveled through tissue containing arterial blood (Nellcor 1993). This can be accomplished through thoughtful LED/photodiode placement. Light impervious barriers should be placed between LEDs and the photodiode in all areas where the emitted light could reach the photodiode without passing through tissue (New and Corenman 1987). Two additional measures can be taken to ensure this (figure 6.6). One is to decrease the angle of incidence to the photodiode. The second is to coat the housing around the photodiode with a material that does not scatter or reflect light.

There are two types of optical interference that may cause problems for the photodiode. The first is excessive ambient light. The source of this type of error may be surgical lamps, fluorescent lights, infrared heat lamps and direct sunlight. Usually this type of interference will saturate the photodiode so that no pulse can be distinguished, however some of these sources may result in apparently normal but inaccurate readings. The second source of interference is optical cross-talk. This type of interference typically may occur when multiple probes are used in close proximity. In this case, light from one LED probe is sensed by the photodiode of another probe.

### 6.4 AMPLIFIERS

Since photodiodes generate an output current, an amplifier must be used to translate that current into a voltage for use by the pulse oximeter. Transimpedance amplifiers, or current-to-voltage converters, are amplifiers that



convert an input current to an output voltage. These are the most common types of amplifiers used in pulse oximetry applications today.

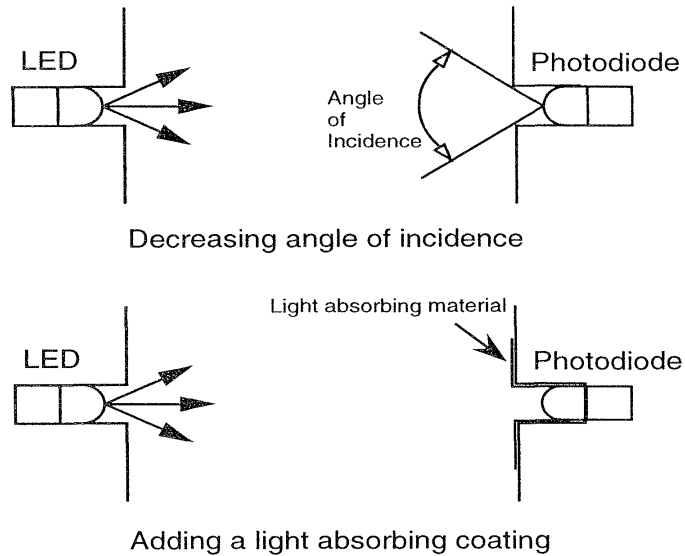

**Figure 6.6** Minimizing photodiode optical interference (adapted from Marktech International 1993).

*6.4.1 Standard transimpedance amplifier configuration*

Figure 6.7 shows the standard transimpedance configuration.

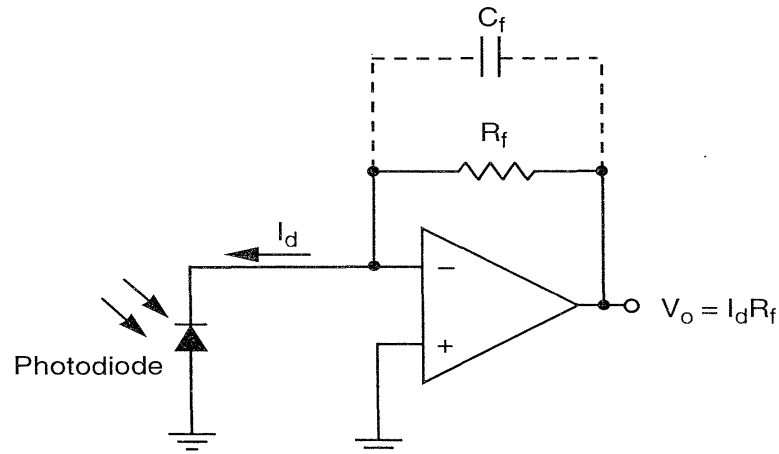

**Figure 6.7** Typical transimpedance amplifier used with a photodiode.

In this configuration, the current generated by the photodiode is converted to a voltage. Because of the virtual ground, the op amp maintains zero voltage across the photodiode. Current flows through the feedback resistor and creates a voltage at the output that is proportional to the light intensity as given by

$$V_0 = I_d R_f. \quad (6.7)$$

The transimpedance gain is then equal to the value of the feedback resistor. Even though standard resistor values can give substantial gains, Cysewska-Sobusiak (1995) noted that the effective transmittance of light through the finger in pulse oximetry applications never exceeds 5%. Even with the use of superbright LEDs, relative light intensity can be expected to be fairly low.

Although the transimpedance amplifier appears to be a simple and straightforward design, it is subject to a number of multidimensional constraints. These constraints have been well documented (Burr-Brown 1994a,b,c, Graeme 1992, 1994, Wang and Ehrman 1994, Kirsten 1996), and several alternative configurations have been proposed. However, because this standard configuration is frequently used in pulse oximetry applications, several general guidelines are provided.

*6.4.1.1 Photodiode capacitance.* Photodiode junction capacitance should be as low as possible. The junction capacitance affects noise and bandwidth of the circuit.

*6.4.1.2 Photodiode active area.* The photodiode active area should be as small as possible for largest signal-to-noise ratio. The area of the photodiode is directly proportional to the junction capacitance. Kästle *et al* (1997) describe an active area of 1 to 2 mm<sup>2</sup> for the Hewlett-Packard sensor.

*6.4.1.3 Feedback resistor.* The feedback resistor should be made as large as possible to minimize noise. This is because the feedback resistor is the dominant source of noise in the circuit. This thermal (Johnson) noise increases as a function of the square root of the value of the feedback resistance.

$$\text{thermal noise} = \sqrt{4kTBR} \quad (6.8)$$

where  $k$  is Boltzmann's constant,  $T$  is absolute temperature,  $B$  is the noise bandwidth (Hz),  $R$  is the feedback resistance ( $\Omega$ ), while the signal voltage increases as a function  $R$ . Therefore the signal-to-noise ratio improves by the square root of the feedback resistance as the feedback resistance is increased.

In addition, a high resistor value of feedback resistance is preferred to an equivalent low resistance T network. Although the transimpedance gain is equivalent, the T network will have a lower signal-to-noise ratio due to current noise and offset voltage.

*6.4.1.4 Op amp.* An FET op amp is a requirement for this configuration. The lower the bias current of the op amp, the higher the sensitivity.

*6.4.1.5 Feedback capacitor.* The capacitor in the feedback loop minimizes gain peaking and improves stability. The choice of capacitor value is critical. Graeme (1992) analyzed this circuit configuration and provided several simplified formulas for determining the appropriate value of feedback capacitance,  $C_f$ . For relatively large area photodiodes, where the junction capacitance is much larger than the feedback capacitor

$$C_f = \sqrt{\frac{C_I}{2\pi R_f f_c}} \quad (6.9)$$

where  $f_c$  is the unity gain frequency of the op amp,  $C_I$  is the total input capacitance = photodiode junction capacitance + op amp input capacitance,  $R_f$  is the feedback resistance.

A more general formula, for use with small photodiode junction capacitances is

$$C_f = \frac{1}{4\pi R_f f_c} (1 + \sqrt{1 + 8\pi R_f C_I f_c}). \quad (6.10)$$

Note that larger values of capacitance can be used but this decreases signal bandwidth where the bandwidth can be calculated by

$$BW = 1.4 f_p$$

where

$$f_p = \sqrt{\frac{f_c}{2\pi R_f (C_I + C_f)}}. \quad (6.11)$$

*6.4.1.6 Shielding.* Since this circuit configuration has high sensitivity and high input impedance, the transimpedance amplifier is sensitive to noise coupling from electrostatic, magnetic, and radio frequency sources.

Electrostatic coupling, typically from ac voltage sources, can create noise in the photodiode/transimpedance amplifier circuit. To prevent this, some pulse oximeter manufacturers have completely enclosed their photodiodes in a metallic shielding such that only the detector surface is exposed. One item of concern is that the shield produces a capacitance between amplifier and ground that may, in some cases, affect the performance of the system.

Magnetically coupled noise is somewhat more difficult to control since it is unaffected by the electrostatic shielding. Sensitive loop areas need to be minimized. High value resistors are sensitive to magnetic coupling so connections between these resistors and op amp inputs should be as short as possible.

Radio frequency interference (RFI) sources should be expected both from the main processing unit of the pulse oximeter itself (as discussed in chapter 8) as well as from other patient monitoring devices. The best prevention is through the use of shielding and filtering. Shielded twisted pair cabling is typically used to send photodiode signals back to the pulse oximeter. The desired photodiode signals of interest are not in the radio frequency range so filtering, even before input to the amplifier, is also effective.

#### *6.4.2 Differential transimpedance amplifier*

Since the photodiode signal of interest is a current, it is available to drive two different inputs in differential fashion as shown in figure 6.8. Since these currents are in different directions, if the feedback resistances are equal, the differential output signal will be twice what it was for the single-ended transimpedance amplifier configuration (figure 6.8). An advantage of this configuration is that for a given gain level, feedback resistor values can be half the single ended configuration shown in figure 6.7. Another benefit of this configuration is the common-mode rejection of coupled noise. By feeding the output of the current-

to-voltage conversion into a differential amplifier stage, noise will show up as a common mode signal on both inputs and have a canceling effect at the circuit output. Note however, that this configuration is not a total replacement for electrostatic shielding, but works well removing coupling that passes through shield imperfections. Several pulse oximeter manufacturers use this configuration in their pulse oximetry systems (Cheung *et al* 1993, Criticare 1990).

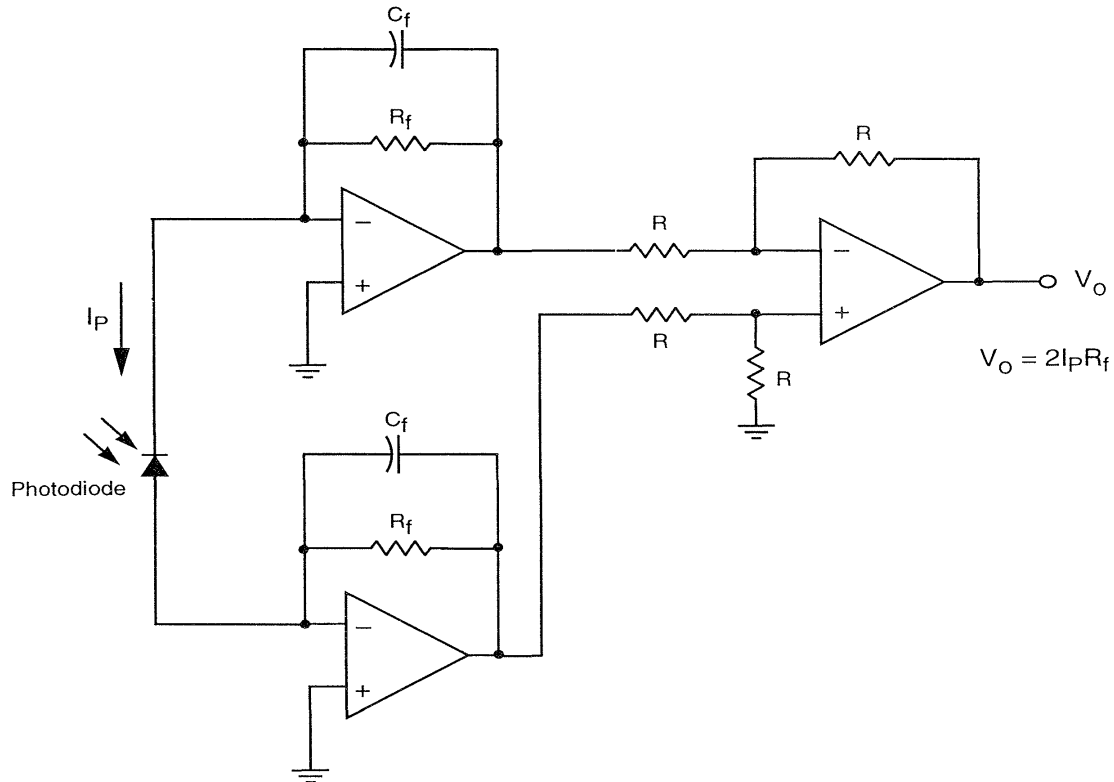
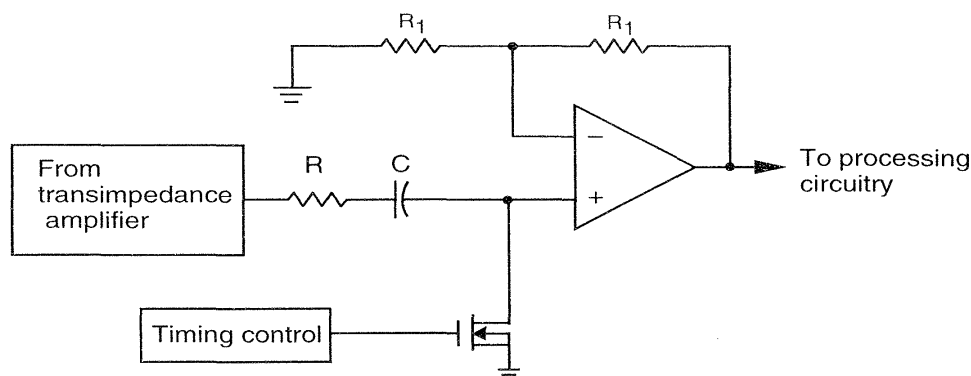

Figure 6.8 Differential current sensing transimpedance configuration.

### 6.4.3 Zeroing circuit

The purpose of the zeroing circuit shown in figure 6.9 is to remove the ambient light signal from the photodiode output signal. To do this, an FET switch is closed, so the  $RC$  network of the output is active. This allows the capacitor to charge up to the voltage equivalent of the ambient light level. The only critical factor in the selection of these components is to make sure the  $RC$  time constant allows for complete charging of the capacitor in the time period allowed (see chapter 8). When an LED is turned on, the FET switch opens, leaving the ambient light level voltage across the capacitor. This will have the net effect of subtracting the voltage across the capacitor from any LED output signal, thereby canceling out the ambient light level. The process repeats itself at the same rate at which the LEDs are pulsing so changes in light level are immediately accounted for. Potratz (1994) presents a similar but different implementation of this circuit with the same general functionality for use in pulse oximetry application.



**Figure 6.9** Typical zeroing circuit used in pulse oximetry applications to remove ambient light offset from the usable signal.

#### 6.4.4 Future trends

At least one manufacturer (Protocol Systems 1992) provides for an electronic switching mechanism on the input to accommodate either a current input directly from a photodiode or a voltage input from an IC sensor. Burr-Brown (1994a,b,c) and Texas Instruments (1993) are two manufacturers that provide ICs that directly integrate the photodiode and transimpedance amplifier to convert a light intensity light directly to a voltage. As these devices drop in price, expect to see these ICs replace the photodiode as the photodetector of choice in future pulse oximetry applications.

#### REFERENCES

- Burr-Brown 1994a OPT101 *Data Sheets: Monolithic Photodiode and Single-Supply Transimpedance Amplifier* (Tucson, AZ: Burr-Brown Corporation)
- Burr-Brown 1994b *Application Bulletin AB-075. Photodiode Monitoring with Op Amps* (Tucson, AZ: Burr-Brown Corporation)
- Burr-Brown 1994c *Application Bulletin AB-077. Designing Photodiode Amplifier Circuits with OPA128* (Tucson, AZ: Burr-Brown Corporation)
- Cheung P W, Gauglitz K F, Hunsaker S W, Prosser S J, Wagner D O and Smith R E 1993 Apparatus for the automatic calibration of signals employed in oximetry *US patent 5,259,381*
- Criticare 1990 *504/504-US Service Manual* (Waukesha, WI: Criticare Systems)
- Cysewska-Sobusiak A 1995 Problems of processing reliability in noninvasive measurements of blood oxygen saturation *Optoelectronic and Electronic Sensors* ed R Jachowicz and Z Jankiewicz *Proc. SPIE* **2634** 163–71
- Fraden J 1997 *Handbook of Modern Sensors, Physics, Designs and Applications 2nd edn* (Woodbury, NY: American Institute of Physics)
- Graeme J 1992 Phase compensation optimizes photodiode bandwidth *EDN*, 7 May: 177–84
- Graeme J 1994 *Applications Bulletin AB-094. Tame Photodiodes with Op Amp Bootstrap* (Tucson, AZ: Burr-Brown Corporation)
- Hitachi 1992 *Opto Data Book* (Brisbane, CA: Hitachi America)
- Kästle S, Noller F, Falk S, Bukta A, Mayer E and Miller D 1997 A new family of sensors for pulse oximetry *Hewlett-Packard J.* **48** (1) 39–53
- Kirsten T R 1996 Increasing photodiode transimpedance bandwidth and SNR with a bootstrap buffer *Sensors* **13** 35–8
- Marktech International 1993 *Optoelectronics data book* (Mendands, NY: Marktech International)
- Nellcor 1993 *Controlling External Optical Interference in Pulse Oximetry. Reference Note: Pulse Oximetry Note Number 5* (Pleasanton, CA: Nellcor)
- New W and Corenman E 1987 Calibrated pulse oximetry probe *US patent 4,700,708*

- Pallas-Areny R and Webster J G 1991 *Sensors and Signal Conditioning* (New York: Wiley)
- Potratz R S 1994 Condensed oximeter system with noise reduction software *US Patent 5,351,685*
- Protocol Systems 1992 *Ultra-Portable Vital Signs Monitor Technical Reference Guide* (Beaverton, OR: Protocol Systems)
- Schibli E G, Yee S S and Krishnan V M 1978 An electronic circuit for red/infrared oximeters *IEEE Trans. Biomed. Eng.* **BME-25** 94–6
- Sharp 1988 *Optoelectronics Data Book* (Mahwah, NJ: Sharp Corporation)
- Siemens 1993 *Optoelectronics Data Book* (Cupertino, CA: Siemens Electronics Corporation)
- Sloan S R 1994 Photodetectors *Photonic Devices and Systems* ed R G Hunsperger (New York: Marcel Dekker)
- Sprague Electric 1987 *Hall Effect and Opto Electronic Sensors* (Concord, NH: Sprague Electric Company)
- Texas Instruments 1993 *Signal Conditioning 1993, Linear Design Seminars Reference Book* (Dallas, TX: Texas Instruments)
- Vig R 1986 Light sensing using optical integrated circuits *Sensors* **3** 6–15
- Wang T and Ehrman B 1994 *Application Bulletin AB-050. Compensate Transimpedance Amplifiers Intuitively* (Tucson, AZ: Burr-Brown Corporation)

## INSTRUCTIONAL OBJECTIVES

- 6.1 Describe why photodiodes are used for light level detection in pulse oximeters.
- 6.2 Sketch the equivalent circuit of a photodiode and explain its operation.
- 6.3 Explain the difference between a  $p-n$  and a  $p-i-n$  diode.
- 6.4 Identify some of the most important characteristics to consider when selecting a photodiode.
- 6.5 Explain some of the techniques used to improve the signal-to-noise ratio when using photodiodes.
- 6.6 Describe some of the sources of optical interference in pulse oximeters.
- 6.7 Sketch a simple transimpedance amplifier configuration and explain its basic operation.
- 6.8 Given a light/current transfer curve of a photodiode, design a transimpedance amplifier.
- 6.9 Explain why the type of covering/filtering over a photodiode's exposed surface is important to the pulse oximeter designer.
- 6.10 Explain why photodiodes are normally configured to use current to indicate light level.
- 6.11 Explain the advantages of a differential amplifier configuration in a photodiode/transimpedance amplifier circuit.

## CHAPTER 7

---

### PROBES

*Moola Venkata Subba Reddy*

Light emitted by the light emitting diodes (LEDs) is partially reflected, transmitted, absorbed, and scattered by the skin and other tissues and the blood before it reaches the detector. The probe of a pulse oximeter consists of two LEDs of selected wavelengths and a detector. The wavelengths of the LEDs chosen are 660 nm and 940 nm (chapter 5) and the detector used is a photodiode (chapter 6). This assembly must be protected from the ambient light for the wavelengths to which the photodiode is sensitive.

The flexible cable connecting the probe and the pulse oximeter unit carries electric power to the LEDs and the signal from the photodiode. Depending on the design, the cable may also contain conductors for a temperature sensor, to detect the temperature of the probe and the underlying skin, and the coding resistor to compensate for the variation of the wavelengths of the emitted light from the LEDs.

#### 7.1 TRANSMITTANCE PROBES

##### *7.1.1 Principle*

As the name suggests, a pulse oximeter with transmittance probes uses the light transmitted through the extremity to measure the arterial oxygen saturation of the blood. Figure 7.1 shows a general transmission probe.

The system employs two LEDs, with emission peak wavelengths at 660 nm in the red range and 940 nm in the infrared range. The LEDs are powered alternately so that light of one particular wavelength will pass through the tissue, and the transmitted light will be detected by the photodiode. The intensity of the light emerging from the tissue is attenuated by the amount of blood present in the tissue. This varies with the arterial pulse and is used as a measure to indicate the pulse rate. The absorption coefficient of oxyhemoglobin is different from that of deoxygenated hemoglobin for most wavelengths of light. For example, the infrared light is absorbed only by molecules made up of dissimilar atoms, because only such molecules (e.g., CO<sub>2</sub>, CO, N<sub>2</sub>O, H<sub>2</sub>O and volatile anesthetic agents) possess an electric dipole moment with which the electromagnetic wave can interact. Symmetric molecules (e.g., O<sub>2</sub>, N<sub>2</sub>, H<sub>2</sub>) do not have an electric dipole

moment and therefore do not absorb infrared radiation (Primiano 1997). Thus differences in the amount of light absorbed by the blood at two different wavelengths can be used to indicate arterial oxygen saturation.

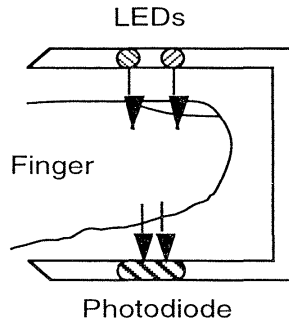

**Figure 7.1** Probe using transmittance principle. Light from two LEDs passes alternately through the tissue of the finger and is detected by the photodiode.

### 7.1.2 Sensor placement

In transmission probes, as the photodiode has to detect the light transmitted through the tissue, the detector is placed in line with the LEDs so that the maximum amount of the transmitted light is detected. The photodiode should be placed as close as possible to the skin without exerting force on the tissue. The amount of force applied by reusable probes is much larger than the amount of force applied by disposable probes. The force applied also depends on the materials used to manufacture a particular probe and also on the company which produces the probes, e.g., Nellcor clip type probes exert less pressure than Ohmeda clip type probes. If the force exerted by the probe is significant, the blood under the tissue, where the probe is placed, may clot due to external pressure applied. And if we increase the distance between the LEDs and the photodiode (optical path length increases), the amount of detected light decreases as seen from Beer's law (section 4.1).

Thus we should place the LEDs and photodiode facing each other. Normally transmission probes are placed on the patient's finger, toe, ear or nose. In a clip type probe, the distance between the LEDs and the photodiode can be as much as 12 mm (without requiring much pressure).

## 7.2 REFLECTANCE PROBES

To measure arterial oxygen saturation, when pulse oximeters with transmission probes cannot be used, pulse oximeters with reflectance probes are used to monitor  $S_aO_2$  based on the intensity of reflected light. The idea of using light reflection instead of light transmission in clinical oximetry was first described by Brinkman and Zijlstra (1949). They showed that  $S_aO_2$  can be monitored by measuring the amount of light reflected (back scattered) from the tissue. The idea of using skin reflectance spectrophotometry marked a significant advancement in the noninvasive monitoring of  $S_aO_2$  from virtually any point on the skin surface.



Even though it was a major advancement, difficulties in absolute calibration and limited accuracy were the major problems with early reflectance pulse oximeters.

### 7.2.1 Principle

The intensity of the back scattered light from the skin depends not only on the optical absorption spectrum of the blood but also on the structure and pigmentation of the skin.

$S_aO_2$  is measured by analyzing the pulsatile components of the detected red and infrared plethysmograms which make use of reflected light intensities. The light from the LEDs enters the tissue, is scattered by both the moving red blood cells and the nonmoving tissue, and a part of this back scattered light is detected by the photodiode. The output of the photodiode is processed by the pulse oximeter, and measures the  $S_aO_2$  of the pulsatile blood.

### 7.2.2 Sensor placement

In reflectance pulse oximetry, the LEDs and the photodiode are placed on the same side of the skin surface as shown in figure 7.2. Normally the reflectance probe is placed on the forehead or temple, but is not restricted to only those two places. Reflectance probes can be used to measure arterial oxygen saturation at virtually any place on the human body where the probe can be placed.

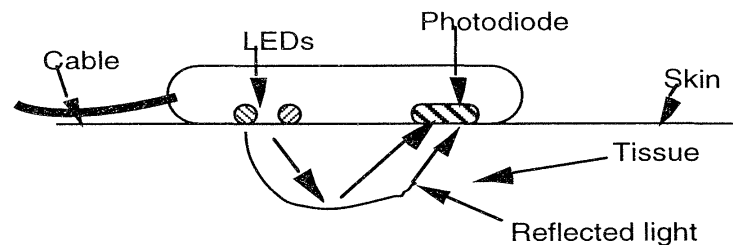

**Figure 7.2** Reflectance probe. The light is transmitted into the tissue, travels through the tissue, and is detected at the photodiode.

**7.2.2.1 Optimum distance between LEDs and photodiode.** One of the major design considerations required in designing a reflectance pulse oximeter sensor is determining the optimum separation distance between the LEDs and the photodiode. This distance should be such that plethysmograms with both maximum and minimum pulsatile components can be detected. These pulsatile components depend not only on the amount of arterial blood in the illuminated tissue, but also on the systolic blood pulse in the peripheral vascular bed.

There are two techniques that can enhance the quality of the plethysmogram. One way is to use a large LED driving current, which determines the effective penetration depth of the incident light, which increases light intensity. So for a given LED/photodiode separation, using higher levels of incident light, we can illuminate a larger pulsatile vascular bed. As a result the reflected plethysmograms will contain a larger AC component. But, in practice, the LED driving current is limited by the manufacturer to a specified maximum power dissipation. The other way is to place the photodiode close to the LEDs. If we place the photodiode too close to the LEDs, the photodiode will be saturated as a result of the large DC component obtained by the multiple scattering of the

incident photons by the blood-free stratum corneum and epidermal layers in the skin.

For a constant LED intensity the light intensity detected by the photodiode decreases roughly exponentially as the radial distance between the LEDs and the photodiode is increased and the same applies to the AC and DC components of the reflected plethysmograms as shown in figure 7.3. Figure 7.4 shows the effect of LED/photodiode separation on the relative pulse amplitude of the red and infrared plethysmograms. This is expected as the probability of the number of photons reaching the photodiode is decreased with the increase in separation.

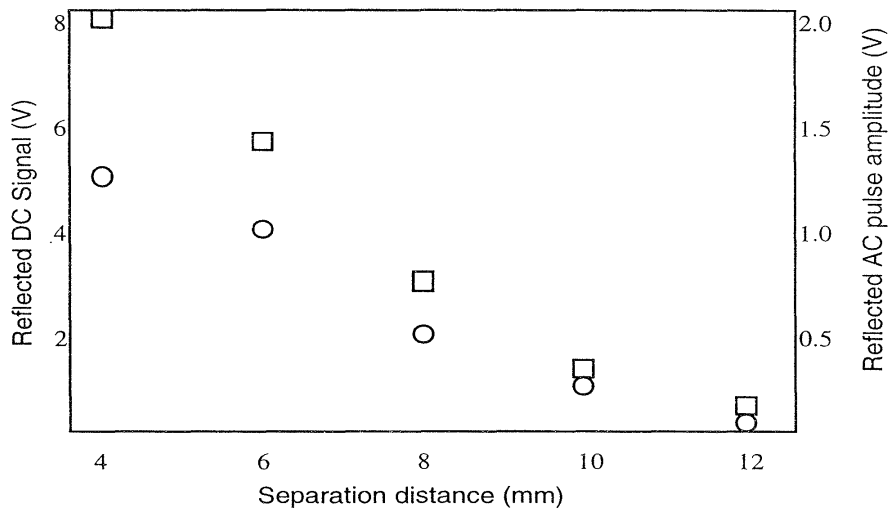

**Figure 7.3** Effect of LED/photodiode separation on the DC (□) and AC (○) components of the reflected infrared plethysmograms. Measurements were performed at a skin temperature of 43 °C (adapted from Mendelson and Ochs 1988).

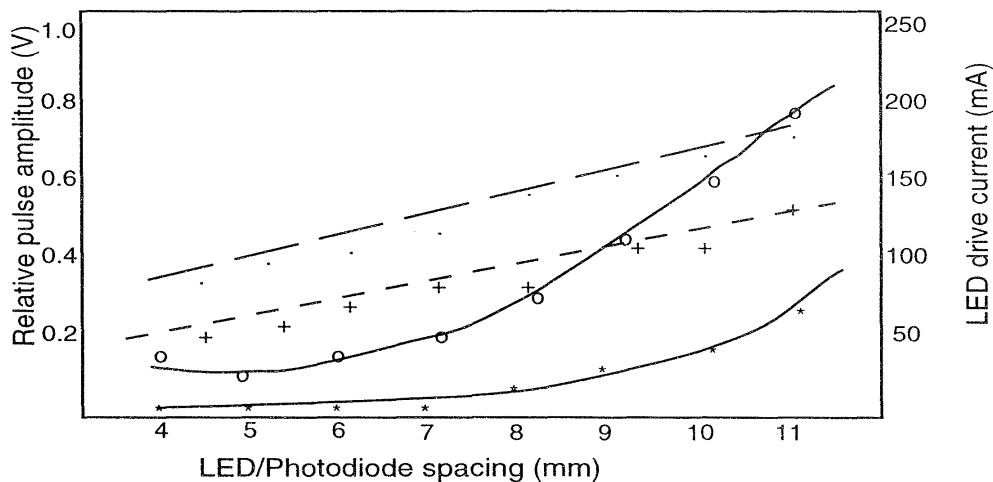

**Figure 7.4** Effect of LED/photodiode separation on the relative pulse amplitude of the red (+) and infrared(·) plethysmograms. The driving currents of the red(o) and infrared(\*) LEDs required to maintain a constant DC reflectance from the skin are shown for comparison (adapted from Mendelson and Ochs 1988).

Thus the selection of a particular separation distance involves a trade-off. We can achieve larger plethysmograms by placing the photodiode farther apart from the LEDs but we need higher LED driving currents to overcome absorption due to increased optical path length.

### 7.2.3 Effect of multiple photodiode arrangement

In a reflectance oximeter, the incident light emitted from the LEDs diffuses through the skin and the back scattered light forms a circular pattern around the LEDs. Thus if we use multiple photodiodes placed symmetrically with respect to the emitter instead of a single photodiode, a large fraction of back scattered light can be detected and therefore larger plethysmograms can be obtained.

To demonstrate this, Mendelson and Ochs (1988) used three photodiodes mounted symmetrically with respect to the red and infrared LEDs; this enabled them to triple the total active area of the photodiode and thus collect a greater fraction of the back scattered light from the skin. The same result can be obtained using a photodiode with three times the area.

### 7.2.4 Effect of skin temperature

Mendelson and Ochs (1988) studied the effect of skin temperature on the quality of signals detected by the photodiode. In their experiment, the LED/photodiode separation was kept constant and after attaching the reflectance sensor to the forearm, they increased the skin temperature to 45 °C in 1 °C step increments.

Figure 7.5 and figure 7.6 show that by increasing the skin temperature from 34 °C to 45 °C, they were able to obtain a five-fold increase in the pulse amplitude.

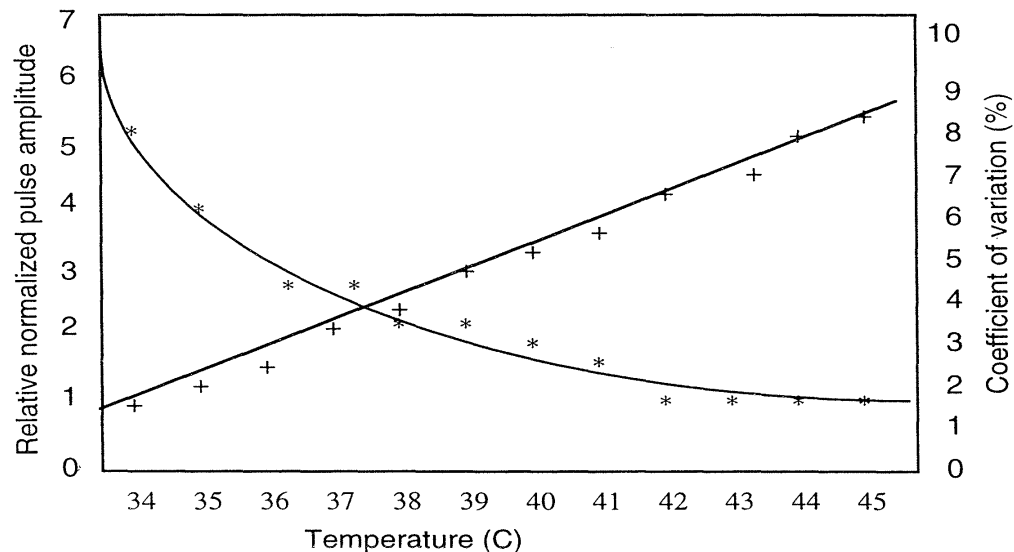

**Figure 7.5** Effect of skin temperature on the mean pulse amplitude (+) and the corresponding decrease in the coefficient of variation (\*) of the infrared plethysmograms. Each pulse amplitude was normalized to a constant separation of 4 mm (adapted from Mendelson and Ochs 1988).

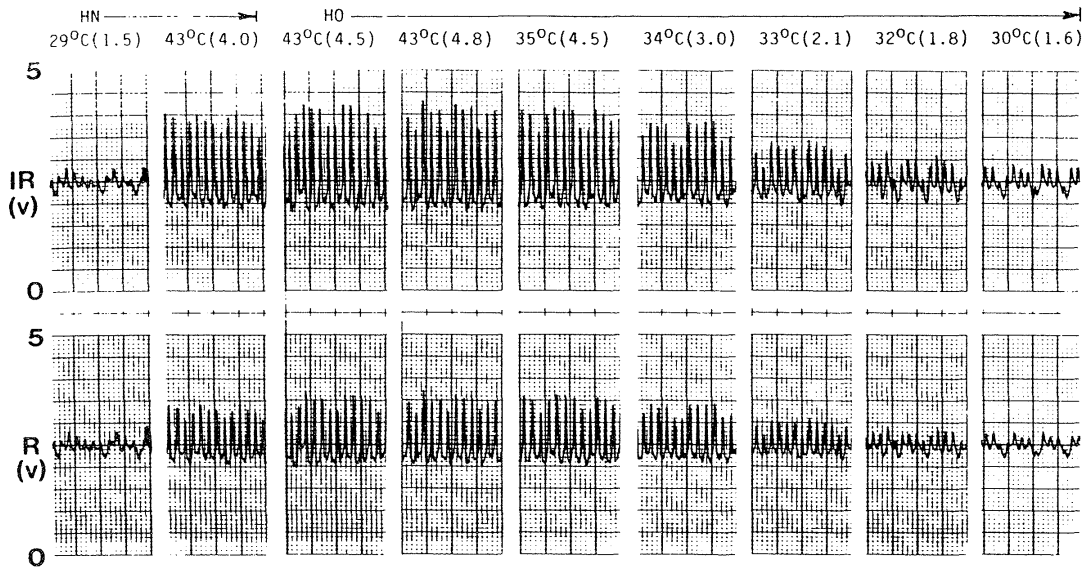

**Figure 7.6** Simultaneous recording of the infrared and red plethysmograms from the forearm at different skin temperatures (from Mendelson and Ochs 1988).

*7.2.5 Advantages and disadvantages of reflectance probes over transmittance probes*

The basic advantage of transmittance probes over reflectance probes is the intensity of the light detected by the photodiode. As the amount of light passing through thin tissue is greater than the amount of light reflected and as the light passing through the tissue is concentrated in a particular area, the intensity of detected light is larger for transmittance probes. The major disadvantage of the transmittance probes is that the sensor application is limited to peripheral parts of the body such as the finger tips, toes, ear and nose in the adults or on the foot or palms in the infant. Reflectance probes can be placed on virtually any place on the body where we can expect light reflection due to tissue.

**7.3 MRI PROBES**

When a pulse oximeter with either transmission or reflection probes is used in the presence of magnetic resonance imaging (MRI), it may give erroneous readings. This is due to the very high magnetic field strengths involved in MRI which makes the use of conventional electronic monitoring equipment difficult. This is due to the radio frequency magnetic pulses generated in the magnetic field. Also if there is any metal connection to the skin of the patient, this could lead to burns.

In order to solve the problems involving MRI, the manufacturers have developed special pulse oximeters for use with MRI scanners. The MR-compatible sensor of Magnetic Resonance Equipment Corporation uses low attenuation optical filter bundles. The complete pulse oximeter unit is kept beyond the field of influence of the magnetic field from MRI and the light from the LEDs is transmitted through the optical fibers and the transmitted/reflected light is brought through the optical fibers to the photodiode. The LEDs, photodiode, and all the electronic equipment required are kept in a main unit

which is kept far away (approximately 3 m) from the MRI equipment. The effect of the magnetic field is minimal on optical fibers when compared to the amplitude of plethysmograph and oximetry signals.

The probes are nearly the same, but instead of LEDs and a photodiode, the MRI probes use fiber optic cables. Figure 7.7 shows a typical clip type probe of Magnetic Resonance Equipment Corporation (MR Equipment 1995).

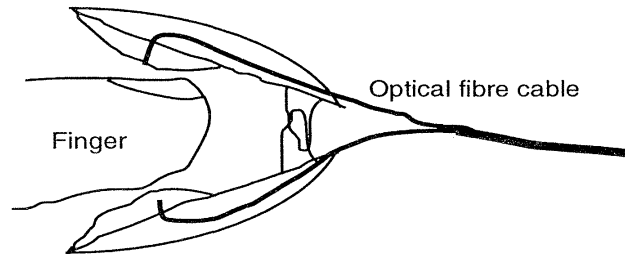

**Figure 7.7** MRI compatible pulse oximeter probe using optical fibers.

#### 7.4 PROBE CONNECTORS

The pulse oximeter may be connected to the subject through a disposable probe. The instrument is used on different subjects (adults, children and infants). The probe can be attached to the subjects by different means, for example the sensors can be attached to the subject's finger, foot, ear or forehead and these require a variety of probes. The hospital should stock a large number of different kinds of pulse oximeter disposable probes, which requires a large inventory.

In order to solve this problem, Goldberger *et al* (1995) used a probe connector, which connects the sensor elements and the cable section of the probe (which is connected to the pulse oximeter instrument). Here they used the fact that money is spent on the cable, so if we can save the cable for multiple use and still use disposable sensors, then we could save money.

The designing of the probe connector should be simple and reliable and should interconnect the sensor elements with the cable that connects the pulse oximeter instrument to the sensor element. The probe connector must be mechanically rugged and should prevent accidental disconnection between the sensor and the instrument. In order to minimize the cost, the electric contacts in the probe connector should be simple and should have low resistance. The conductors in both halves of the probe connector should be precisely aligned with each other in order to avoid susceptibility to electromagnetic interference. Figure 7.8 shows the probe connector used in Ohmeda pulse oximeter probes.

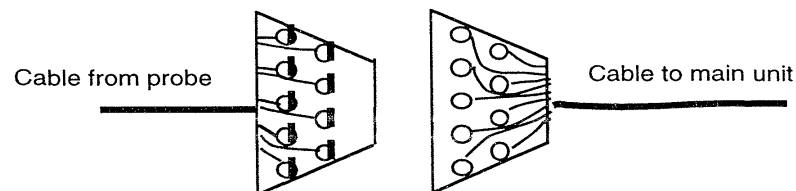

**Figure 7.8** Probe connector used in Ohmeda pulse oximeter units. The cable from the probe has 9 male pins that mate with the 9 female sockets on the cable to the main unit.

7.5 REUSABLE PROBES

Probes which can be used more than once in monitoring  $S_aO_2$  are called reusable probes. Generally all probes with nonadhesive or disposable adhesive sensors are reusable probes. Figure 7.9 shows the most common of them, which is a clip (or clamp) type sensor used over the patient's finger. Figure 7.10 shows a reusable sensor with disposable adhesive wrap) and figure 7.11 shows a reusable reflectance sensor applied over the forehead with a disposable adhesive pad.

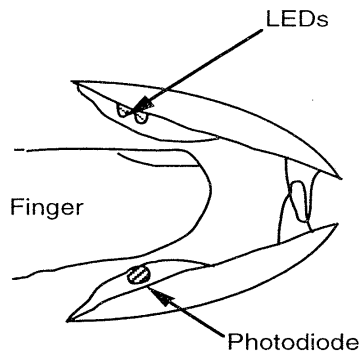

Figure 7.9 Clamp (or clip) type reusable probe.

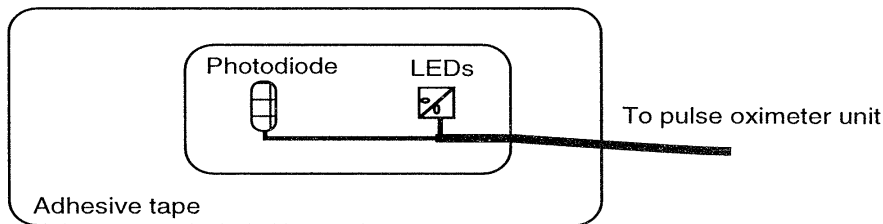

Figure 7.10 Reusable probe with disposable adhesive sensors.

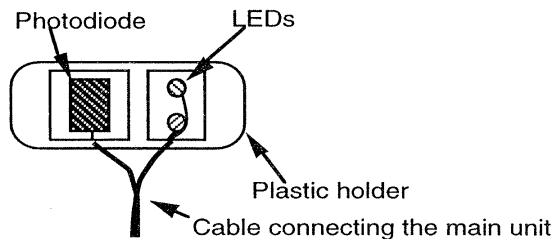

Figure 7.11 Reusable reflectance sensor.

The main advantage of the reusable probes is the low per use cost involved. By using the same probe over and over we reduce the total cost for the patient. However reusable sensors require cleaning between patients to minimize the risk of cross contamination. In the case of infected patients or patients with a high risk of infection (e.g., neonates and immunosuppressed patients) reusable probes are

not recommended. Moreover, clip type sensors are more susceptible to signal-distorting motion artifacts.

Reusable sensors are commonly used for on the spot measurements or for short term monitoring (usually of less than four hours). Reusable sensors should be changed to another site at least every four hours.

Kästle *et al* (1997) describe design considerations for reusable probes that include functionality, performance and regulations. They used a thin, flexible probe cable to minimize movement artifacts. They designed watertight connectors to the heavier adapter cable to avoid leakage. Electrical shielding minimized electrical interference and a closed, opaque housing minimized optical interference.

## 7.6 DISPOSABLE PROBES

As the name indicates disposable probes are discarded after they have been used. Since disposable probes are used on a single patient, they eliminate the possibility of cross contamination. All adhesive sensors are disposable sensors. They decrease the effect of signal distortions as they secure the sensor in the proper position and the relative motion between the patient and the sensors is nearly zero. Adhesive sensors are most commonly used when there is a need for monitoring when the electromagnetic interference levels in the surroundings is high (or if the signal obtained is low), as the electromagnetic shielding around the sensor and cable protects the pulse oximetry signal.

Adhesive sensors are used for both short term and long term monitoring. Typically adhesive sensors are checked at least every eight hours. Figure 7.12 shows a typical disposable probe.

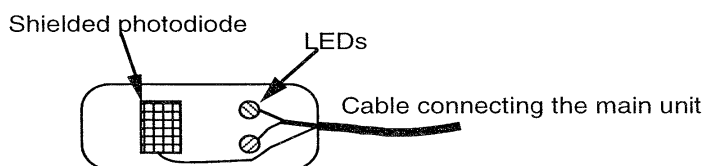

**Figure 7.12** Disposable probe.

## 7.7 SOURCES OF ERRORS DUE TO PROBES AND PLACEMENT

### 7.7.1 Ambient light interference

Ambient light from sources such as sunlight, surgical lamps etc may cause errors in  $S_aO_2$  readings. In order to prevent this, the simple solution is to cover the sensor site with opaque material which can prevent ambient light from reaching the photodiode.

### 7.7.2 Optical shunt

Optical shunting occurs when light from the sensor's LEDs reaches the photodiode without passing through the tissue. Optical shunting leads to erroneous readings in the value of  $S_aO_2$  as the amount of light detected by the photodiode is greatly increased by optical shunting. This can be eliminated by choosing an appropriate sensor for the patient's size and by ensuring that the sensor remains securely in position.

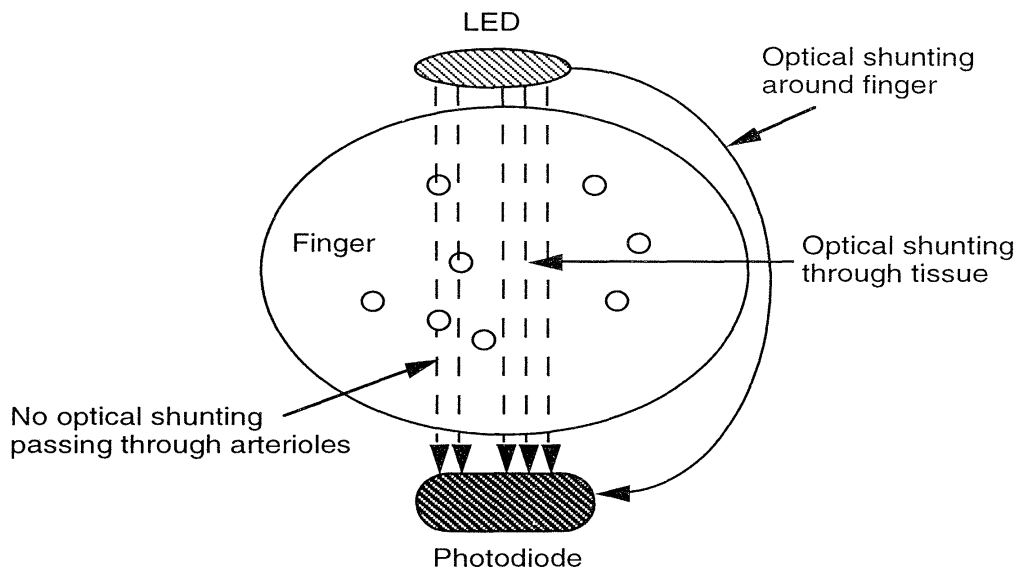

**Figure 7.13** Light that does not pass through arterioles causes optical shunting.

### 7.7.3 Edema

Edema is defined as an abnormal accumulation of serous fluid in a connective tissue or in a serous cavity, in other words swelling in the body. When the probe is used over such a swelling, the resultant arterial oxygen saturation reading may not be accurate as the fluid in the swelling changes the absorbed and reflected light. This changes the intensity of light detected by the photodiode, resulting in an erroneous reading. By placing the probe on a nonedematous tissue, this error can be avoided.

### 7.7.4 Nail polish

Certain colors of nail polish, especially blues, greens, browns, and black, absorb so much light that the detected light is too small. Then the resultant  $S_aO_2$  may be inaccurate. Thus nail polish of these colors should be removed.



## REFERENCES

- Brinkman R and Zijlstra 1949 Determination and continuous registration of the percentage of the percentage oxygen saturation in small amounts of blood *Arch. Chir. Neerl.* **1** 177–83
- Cheung P W, Gauglitz K F, Hunsaker S W, Prosser S J, Wagner D O and Smith R E 1993 Apparatus for the automatic calibration of signals employed in oximetry *US patent 5,259,381*
- Criticare 1995 *Product Catalog* (Waukesha, WI: Criticare Systems)
- Delonzor R 1993 Disposable pulse oximeter sensor *US patent 5,246,003*
- Goldberger D S, Turley T A and Weimer K L 1995 Pulse oximeter probe connector *US patent 5,387,122*
- Kästle S, Noller F, Falk S, Bukta A, Mayer E and Miller D 1997 A new family of sensors for pulse oximetry *Hewlett-Packard J.* **48** (1) 39–53
- Larsen V H, Hansen T and Nielsen S L 1993 Oxygen status determined by the photo-electric method – a circular finger probe constructed for detection of blood oxygen content, blood flow and vascular density *Lab Invest.* **53** Suppl. 214 75–81
- Mannheimer P D, Chung C, Ritson C 1993 Multiple region pulse oximetry probe and oximeter *US patent 5,218,962*
- Mendelson Y and Ochs B D 1988 Noninvasive pulse oximetry utilizing skin reflectance photoplethysmography *IEEE Trans. Biomed. Eng.* **35** 798–806
- MR Equipment 1995 *Product Catalog* (Bay Shore, NY: Magnetic Resonance Equipment Corp)
- Nellcor 1995 *Product Catalog* (Hayward, CA: Nellcor Incorporated)
- Nelson D 1995 Molded pulse oximeter sensor *US patent 5,425,360*
- O’Leary R J Jr, Landon M and Benumof J L 1992 Buccal pulse oximeter is more accurate than finger pulse oximeter in measuring oxygen saturation *Report Department of Anesthesiology, University of California—San Diego*
- Ohmeda 1996 *Product Catalog* (Louisville, CO: Ohmeda)
- Pedan C J, Daugherty M O and Zorab J S 1994 Fiberoptic pulse oximetry monitoring of anaesthetized patients during magnetic resonance imaging *Eur. J. Anaesthesiol.* **11** 111–3
- Pologe J A 1987 Pulse oximetry: technical aspects of machine design *Int. Anesthesiol. Clinics* **35** 137–53
- Primiano F P Jr 1998 Measurements of the respiratory system *Medical Instrumentation: Application and Design* 3rd edn J G Webster ed (New York: Wiley)
- Santamaria T and Williams J S 1994 Pulse oximetry *Medical Device Research Report* **1** (2)
- Sugiura K 1995 Pulse oximeter probe *US patent 5,413,101*
- Young R L, Heinzelman B D and Lovejoy D A 1993 Noninvasive oximeter probe *US patent 5,217,012*

## INSTRUCTIONAL OBJECTIVES

- 7.1 Explain how transmission probes work.
- 7.2 List the main constraints in the use of transmission probes.
- 7.3 Explain what we need to look at, when placing the emitter and detector of the pulse oximeter probe on the patient.
- 7.4 Explain how the reflection probes work.
- 7.5 Explain when we need to use reflectance probes.
- 7.6 Explain the effects of skin temperature over reflectance probes.
- 7.7 Explain the advantages of using multiple detectors in reflectance probes.
- 7.8 Explain why the need to use MRI probes arises.
- 7.9 List the precautions that should be taken in using MRI probes.
- 7.10 Compare reusable and disposable probes.
- 7.11 Explain the common sources of error in pulse oximeters due to probes and explain how we can prevent them.

## CHAPTER 8

---

# ELECTRONIC INSTRUMENT CONTROL

*Ketan S Paranjape*

The pulse oximeter consists of an optoelectronic sensor that is applied to the patient and a microprocessor-based system (MBS) that processes and displays the measurement. The optoelectronic sensor contains two low-voltage, high-intensity light-emitting diodes (LEDs) as light sources and one photodiode as a light receiver. One LED emits red light (approximately 660 nm) and the other emits infrared light (approximately 940 nm). The light from the LEDs is transmitted through the tissue at the sensor site. A portion of the light is absorbed by skin, tissue, bone, and blood. The photodiode in the sensor measures the transmitted light and this signal is used to determine how much light was absorbed. The amount of absorption remains essentially constant during the *diastolic* (nonpulsatile) phase and this measurement is analogous to the reference measurements of a spectrophotometer. The amount of light varies during the *systolic* (pulsatile) phase. This chapter describes the electronics that control the operation of the pulse oximeter. The heart of this unit is the MBS, which controls the operation of this device from the light input to the display output. The signal received by the photodiode is small and may contain noise, so the first step involves amplification and filtering. Then the signals are split into the infrared (IR) and the red (R) components. Synchronizing with the R wave of the ECG signal helps to minimize motion artifacts. This chapter describes the electronics for the optoelectronic sensors, MBS, analog signal processing, power requirements, display and finally the storage of data.

### 8.1 GENERAL THEORY OF OPERATION

Measurements of oxygen saturation require light of two different wavelengths, as explained in chapter 4 (Pologe 1987). Two LEDs (one IR and one R) emit light, which is passed through the tissue at the sensor site into a single photodiode. The LEDs are alternately illuminated using a four-state clock. The photodiode signal, representing light from both LEDs in sequence, is amplified and then separated by a two-channel *synchronous detector* (demodulator), one channel sensitive to the infrared light waveform and the other sensitive to the red light waveform. These signals are filtered to remove the LED switching frequency as well as electrical and ambient noise, and then digitized by an analog-to-digital converter (ADC). The digital signal is processed by the microprocessor to identify

individual pulses and compute the oxygen saturation from the ratio of the signal at the red wavelength compared to the signal at the IR wavelength.

The pulse oximeter does not measure the functional oxygen saturation because along with oxygenated and deoxygenated hemoglobin other forms of hemoglobin also exist. It may produce measurements that differ from those instruments that measure fractional oxygen saturation. As the pulse oximeter uses two wavelengths it can estimate only the oxygenated and deoxygenated (i.e., functional) hemoglobin. It does not determine the significant amount of dysfunctional hemoglobin (MetHb or COHb). The oxygen saturation measured is not exactly the arterial oxygen saturation ( $S_aO_2$ ), but is termed pulse oximeter measured oxygen saturation,  $S_pO_2$ .

### 8.1.1 Historic perspective

Various patents describe the electronics involved for saturation calculation. Nielsen (1983) describes a logarithmic amplifier to amplify the output current to produce a signal having AC and DC components and containing information about the intensity of light transmitted at both wavelengths. *Sample-and-hold* units demodulate the R and IR wavelengths signals. In the sample and hold circuits the common signal from the photodiode is split into the IR and R components by the control signals from the MBS. The mixed signal is fed into the sample-and-hold circuit, whose timings are controlled such that each circuit samples the signal input during the portion of the signal corresponding to the wavelength to which it responds. The DC components of the signals are then blocked by a series of bandpass filters and capacitors, eliminating the effect of fixed absorptive components from the signals. The resultant AC signal components are unaffected by fixed absorption components, such as hair, bone, tissue, and skin. An average of the peak-to-peak value of each AC signal is produced, and the ratio of the two averages is then used to determine the saturation from empirically determined values associated with the ratio. The AC components are also used to determine the pulse ratio. The pulse ratio is the ratio of the R ac signal and the IR ac signal.

Wilber (1985) describes a photodiode sensor used to produce a signal for each wavelength having a DC and AC component. A normalization circuit employs *feedback* to scale the two signals so that the nonpulsatile DC components of each are equal and the offset voltages are removed. *Decoders* separate the two signals into two channels, where the DC components are removed. The remaining AC components are amplified and multiplexed along with other analog signals prior to being sent into an ADC. The oxygen saturation is then determined using the MBS.

New (1987) describes each LED having a one-in-four *duty cycle*. A photodiode produces a signal in response that is then split into two channels. The one-in-four duty cycle allows negatively amplified noise signals to be integrated with positively amplified signals including the photodiode response and noise, thereby eliminating the effect of noise on the signal produced. The resultant signal has a large DC component along with the small AC component. To improve the accuracy of the ADC this DC component is first subtracted prior to conversion, and is subsequently added back by the MBS. A quotient of the AC to DC components is determined for each wavelength of transmitted light. The ratio of the two quotients is fitted to an empirical curve of independently derived oxygen saturation (CO-oximeter). See chapter 10 for further details. To

compensate for the different transmission characteristics, an adjustable drive source for the LEDs is provided.

New (1987) uses a calibrated oximeter probe. This probe includes a coding resistor that is used to identify a particular combination of wavelengths of the two LEDs. The *coding resistor* value is sensed by the MBS, and in this manner the effect the different wavelengths have on the oxygen saturation is compensated for. The oxygen saturation is calculated using the empirical curve (New 1987).

### 8.2 MAIN BLOCK DIAGRAM

Figure 8.1 shows the block diagram of the pulse oximeter system. The probe houses the transmitting LEDs and the receiving photodiode. The patient module contains the ECG amplifier. The photodiode signal, the ECG signal and the coding resistance value are sent to the MBS unit via the patient cable.

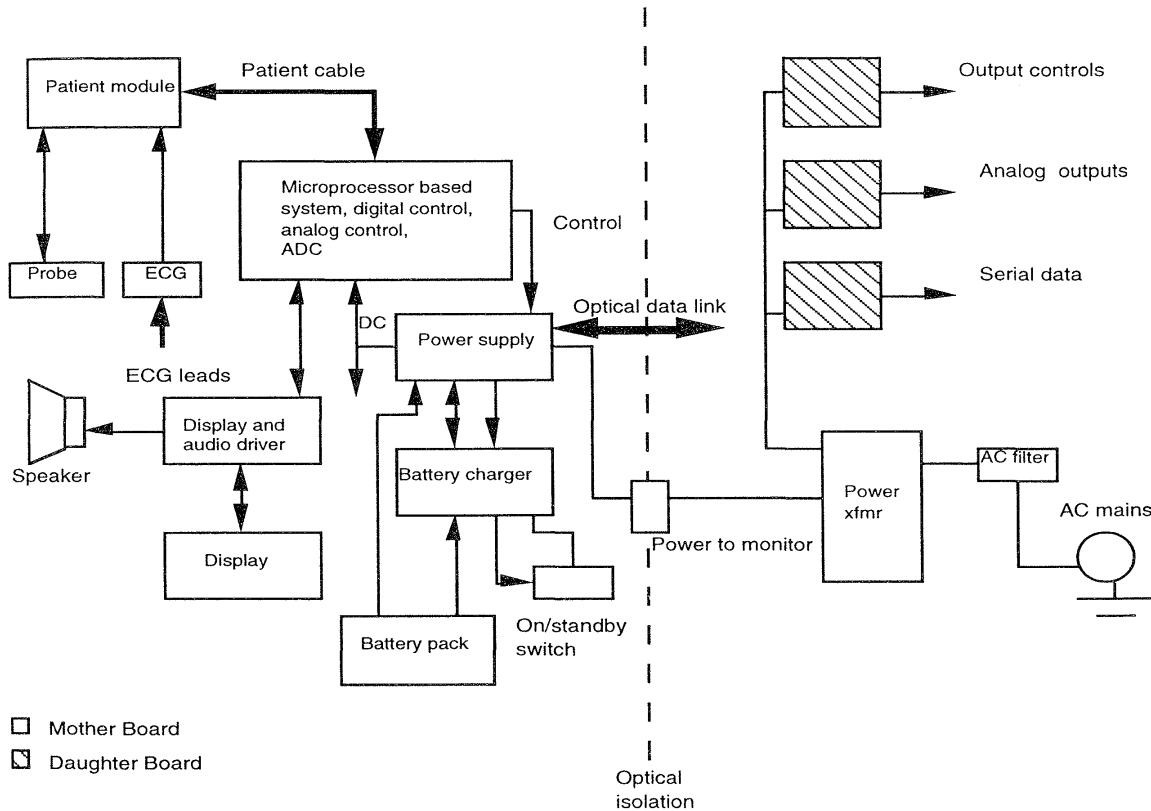

**Figure 8.1** Main block diagram of a pulse oximeter system . Adapted from Nellcor N-200® (Nellcor 1989).

The MBS houses the digital and analog circuitry along with the ADC. The MBS is responsible for generating the various control signals of the system. The on board power supply is powered by a battery pack. A display driver drives the display section.

The section on the grounded side of the optical isolation consists of various cards such as the serial data communication card and certain analog and control outputs. The power transformer is located on this section. The main reason for the optical isolation is to prevent electric shock to the patient.

### 8.2.1 Input module

Figure 8.2 shows the input module or the patient module, which contains a preamplifier to generate the detector voltage ( $V_{det}$ ) and electrocardiogram (ECG) signals used in ECG synchronization. Power for the circuitry is obtained from an on board power supply.

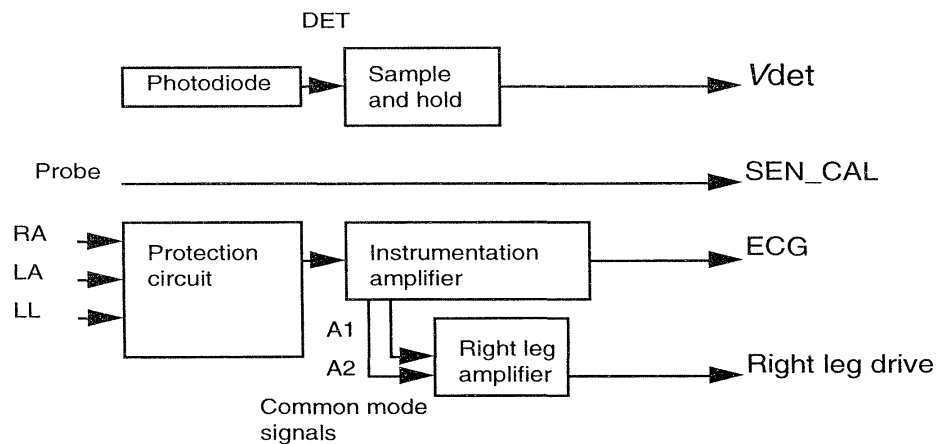

**Figure 8.2** Input module or the analog front end module consisting of the detector, ECG unit, Protection unit and amplifiers. Adapted from Nellcor N-200® (Nellcor 1989).

The driver current for the pairs of probe LEDs is supplied from the LED driver circuit section. This waveform is a bipolar current drive which is passed through the input module to the back-to-back probe LEDs. A positive current pulse drives the IR LED and a negative current pulse drives the red LED. The drive current is controlled by a feedback loop in response to photodiode response. This feedback loop is controlled by the MBS.

The photodiode generates a current proportional to the amount of light received. The saturation preamplifier converts the photodiode current to a voltage. The conversion ratio is initially determined and fixed. Its units are  $mV/\mu A$ . A voltage regulator biases the preamplifier to a voltage output for zero current input. This bias helps to increase the swing of the current-to-voltage converter to its largest output. Some additional voltage margin is left in case of high ambient light conditions.

An *instrumentation amplifier* preamplifies the ECG signal used in ECG synchronization. The protection circuit consists of neon lamps to protect the instrumentation amplifier from potentially damaging high-voltage pulses which may result during defibrillation. Series resistors provide further isolation from high transient currents. Diodes shunt high-voltage transients to the low-impedance power supplies. Additional resistors pull the input signal lines to the

power supply voltage levels when an ECG signal lead has become detached. By detecting a lead off, the pulse oximeter can indicate that the ECG synchronization is lost.

*Common mode signals* A1 and A2 from the instrumentation amplifier are summed, amplified, and inverted through the driven right leg amplifier. The output of this amplifier is fed back to the patient to drive the patient to a low common mode voltage by measuring the common mode voltage at the input sensing leads (driven right leg amplifier). In the *driven right leg* configuration, rather than the patient being grounded the right leg electrode is connected to the output of an auxiliary op amp. The body displacement current flows not to ground but rather to the op amp output circuit. This reduces the interference into the ECG amplifier and effectively grounds the patient. The ECG signal from the instrumentation amplifier goes directly to the ADC and finally to the MBS.

The probe connector contains a coding resistor that codes the wavelengths of the red and infrared LEDs mounted in the sensor (Sen\_Cal). Because the wavelengths of the red and IR LEDs vary from one probe to another, an error would result in the computation for oxygen saturation if not corrected for by using the coding resistor. This coding resistor is measured and the value provided to the processing system. Since the probe is located near the patient, this coding resistor is sealed in epoxy to prevent damage from moisture and is nonrepairable. Therefore in case of any damage to the probe, or in the event of a failure the entire assembly has to be replaced.

## 8.3 DIGITAL PROCESSOR SYSTEM

### 8.3.1 Microprocessor subsection

The most important component of this system is the microprocessor. The microprocessor along with memory, input/output devices, communication circuits and additional peripheral devices constitutes the Microprocessor Based System (MBS). Depending on the application and the processing requirements, sometimes the microprocessor is replaced by a microcontroller. A *microcontroller* consists of a microprocessor, additional memory, ports and certain controls all built on the same chip. In portable pulse oximeters where power consumption and size are the main constraints microcontrollers may be used.

The processing power of a pulse oximeter lies in the microprocessor and how well it is configured along with memory to perform at a certain level. From the Intel line of microprocessors the 8085, the 8086, and the 8088 are the most commonly used devices, along with some other devices which may be designed for specified needs or dedicated for a certain kind of application. This chapter describes a standard Intel 8088, configured in the minimum mode, and used on Nellcor's N-200<sup>®</sup> series (Nellcor 1987).

*8.3.1.1 Memory and memory mapping.* The memory section usually consists of a mixture of *Random Access Memories* (RAMs) and *Read Only Memories* (ROMs). The memory has two purposes. The first is to store the binary codes for the sequences of instructions the subsystem is to carry out, such as determining the correct calibration curve depending on the probe used. The second is to store the

binary-coded data with which the subsystem will work, such as the pulse rate or ECG data.

**8.3.1.2 Input/output.** This section allows the subsystem to take in data from the patient or send data out. Signals from the probe (photodiode output and ECG) are the input signals and the LED drive signals and display signals are the output signals. Ports are special devices used to interface the subsystem buses to the external system. The input port can receive signals from an ADC, and the output port sends signals to a printer or a digital-to-analog converter (DAC).

### 8.3.2 General block description

Figure 8.3 shows the most common configuration used for a microprocessor-based system. The main control signals may vary from make to make. If a microcontroller is used then there may be some reduction in the number of chips on board, thereby reducing the number of control lines on board.

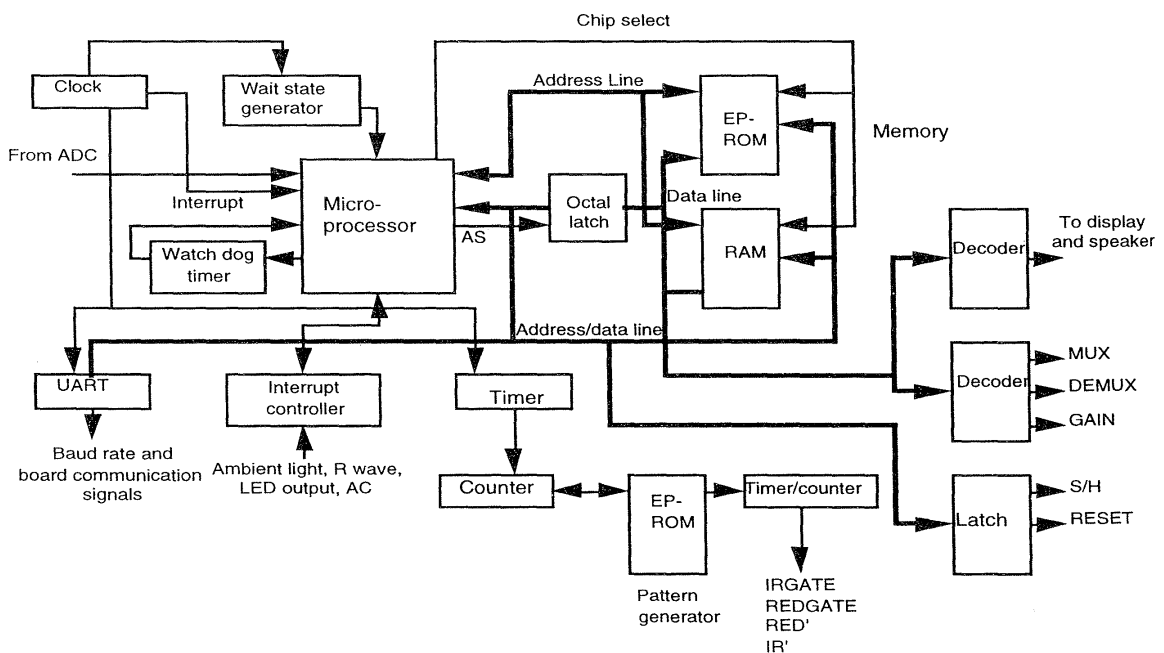

**Figure 8.3** Generic microprocessor-based system. The ADC input to the microprocessor consists of the signal received from the photodiode, ECG signal for R-wave synchronization etc.

The microprocessor could be an Intel 8085 (Nellcor N-200)<sup>®</sup> or Zilog Z-80 (Ohmeda 3740(Ohmeda 1988))<sup>®</sup>. The clocking circuit consists of the clock generator and the *wait state generator*. For synchronized operation the clock rate must be constant and stable. For this reason a crystal oscillator is used. The wait state generator is used to slow down the microprocessor with respect to the input/output devices connected.

The communication section consists of the *Universal Asynchronous Receiver and Transmitter (UART)*, along with the *interrupt* control signals. This communication section makes use of the memory and control signals available on

board. Timers and counters are employed to generate pulse trains required for the pattern generator section.

The pattern generator section is used to generate control sequences. This information is stored in the *EPROM* and is withdrawn using the address supplied by the counter that increments or decrements as desired. The *IRGATE* and the *REDGATE* are the two control signals used to *demodulate* the incoming photodiode output. The *RED'* and the *IR'* signals are used to synchronize the outputs of the two multiplexers so that they are combined before being fed into the voltage-to-current converter (figure 8.8), where a bipolar current output is generated to be fed into the two LEDs tied back-to-back that act as a source.

The memory on board consists of *latches*, buffers, decoders, RAMs, ROMs and EPROMs that are used to store the calibration curve data, digitized data from the photodiode that needs processing and storing data to generate the control signals. Oxygen saturation and pulse rate data can be stored in this memory. Octal transparent latches are needed to demultiplex the address and data bus information. EPROMs are erasable memory devices that store information such as the calibration curves, compensation requirements, etc., which may need occasional change. Therefore in such cases the technicians could reprogram or burn this new information into the chip. The set of instructions to be executed by the pulse oximeter is stored in the ROMs and RAMs. The code stored for example may be used for signal processing.

Finally decoders are used to decode the address and data information to generate the required control signals. The *DEMUX/MUX* signals are used to demultiplex the photodiode output into the individual IR and red signals, and the multiplexer is used to multiplex the IR and red signals, to drive the LEDs. Signals such as *GAIN* are used to adjust the gain requirements of offset amplifiers or *programmable gain amplifiers* used in the analog-to-digital conversion. *RESET* is generated in response to a *high* from the *watchdog timer*, which could mean temporarily shutting the system down.

### 8.3.3 Wait state generator

The pulse oximeter has a hardware–software interface that allows analog signals to be accepted, digitized, analyzed, processed, and finally converted back to analog to drive the LEDs. The rate at which the data enter the MBS or leave the MBS depends on the various components on the board and the communication/data transfer rate. These data may arrive at irregular intervals, and may need to be delayed before they are transferred to the output section. Therefore the MBS must generate some wait states to take care of these delays. The wait state generator is used to generate a wait state of one clock cycle. The microprocessor will insert the selected number of wait states in any machine cycle which accesses any device not addressed on the board, or any I/O device on the board. The purpose of inserting wait states is to give the addressed device more time to accept or output data. In this configuration, we use either a *shift register* or a *D flip flop*. A shift register or a D flip flop are digital devices which when controlled via clock signals can store and release data.

### 8.3.4 Clock generator, timer circuit and UART

The timing control on a microprocessor subsystem is of extreme importance. The rate at which the different components on the MBS receive data, analyze, and



process it, is dependent on the clock rate. The clock controls the duty cycle. Duty cycle is defined as the fraction of time the output is high compared to the total time. When designing such subsystems we have to examine the duty cycle.

*8.3.4.1 Clock generator and timer circuit.* A 555 timer can be used to generate a  $n$ -minute timer, but isn't accurate enough for this kind of application. For more precise timing we usually use a signal derived from a crystal-controlled oscillator. This clock is stable but is too high in frequency to drive a processor interrupt input directly. Therefore, it is divided with an external counter device to an appropriate frequency for the interrupt input. Usually such a system contains counter devices such as the Intel 8253 or 8254, which can be programmed with instructions to divide an input frequency by any desired number.

The big advantage of using these devices is that you can load a count into them, and start them and stop them with instructions in a software program. Sometimes addition of a wait state may be needed along with this device to compensate for the delay due to the decoders and buffers on board.

We usually reset the circuit using simple resistors and capacitors, which are held low during power-on. This maintains the logic at a known state, while the crystal oscillator and the power supplies stabilize.

The timer circuit could control the following units on the subsystem:

1. Set the baud rate of the UART communication network.
2. Generate interrupts for controlling the display circuit, as these are usually multiplexed to avoid use of high current.
3. Audio frequency generator, for alarms.
4. Clock frequency for the notch filter, used to suppress the power line noise.
5. Synchronous circuit operation for pattern generator.

*8.3.4.2 Watchdog timer circuit.* This is a kind of fail-safe timer circuit, which turns the oximeter off if the microprocessor fails.

A counter controls the input to a D flip-flop, which is tied to a shutdown signal in the power supply. The counter is reset using a control signal from the microprocessor and a latch. Using some current-limiting protection, this signal is ac-coupled to the reset input of the counter. Therefore if the counter is not reset before the counter output goes high, the flip-flop gets set and the power supply is turned off.

*8.3.4.3 UART.* Within a MBS, data are transferred in parallel, because that is the fastest way to do it. Data are sent either *synchronously or asynchronously*. A UART (Universal Asynchronous Receiver Transmitter), is a device which can be programmed to do asynchronous communication.

### *8.3.5 Pattern generator*

This is a multipurpose section which is primarily used to generate timing patterns used for synchronous detection gating, LED control, and for synchronizing the power supply. The heart of this system is the EPROM (Erasable Programmable ROM). Here preprogrammed bit patterns are stored and are cycled out through the counter, and are tapped off using certain address lines. Using the address the bit pattern is sent out and latched using an octal latch. There may be an additional

latch used to deglitch the system, in which the last byte is held until the counter increments itself to the next address and the next pattern is obtained. Various patterns within the EPROM are used to select the sampling speeds of the LEDs or the synchronous detector pulse, the calibration patterns and diagnostic timing.

## 8.4 ANALOG PROCESSING SYSTEM (NELLCOR<sup>®</sup>)

### 8.4.1 Analog signal flow

Signals obtained are usually weak and may have electromagnetic interference. These signals must be filtered and then amplified. Usually a 50 or 60 Hz low-pass (for example may be a 2nd order Butterworth) filter is used. The signal is then ac coupled to stages of amplifiers and depending on the kind of response, variable gain circuits can be designed. The aim here is to maximize the signal before it enters the detector circuit, where the IR and red signal are separated, so the signal-to-noise ratio (SNR) is also kept as high as possible.

### 8.4.2 Coding resistor, temperature sensor, and prefiltering

Before examining the analog signal flow path, it is necessary to mention how the MBS decides what compensation to use for those LEDs which do not have their peak wavelength at the desired value. As LEDs are manufactured in bulk and tested in a random fashion, the probes may not always have the LEDs with the desired wavelength. Therefore the MBS generates some compensation, in order to solve this problem. Probes must be calibrated. Pulse oximeter systems have a coding resistor in every probe connector. A current is provided to the probe which allows the MBS to determine the resistance of the coding resistor by measuring the voltage drop across it. Thus the particular combination of LED wavelengths can be determined. Following this the MBS can then make necessary adjustments to determine the oxygen saturation.

As the wavelengths of the LEDs depend on the temperatures, for accurate measurements the effects of the temperatures must also be known, for adequate compensation (Cheung *et al* 1989). A temperature sensor may be employed, whose signal along with that of the coding resistor is used to select the calibration curves which are to be employed for compensation.

Despite efforts to minimize ambient light interference via covers over the probes and sometimes red optical filters, interfering light does reach the photodiode. Light from the sun and the incandescent lamp are continuous. The fluorescent light source emits ac light. This may overload the signal produced by the photodiode in response to the light received.

### 8.4.3 Preamplifier

The photodiode generates a current proportional to the light incident upon it. The signal from the photodiode is received by a preamplifier. Figure 8.4 shows that the preamplifier consists of a differential current-to-voltage amplifier and a single ended output amplifier. A gain determination resistor converts the current flowing through it into voltage. But along with the current-to-voltage conversion, external interference is also amplified, making the true signal difficult to extract

from the resulting output. The differential amplifier produces positive and negative versions of the output. This dual signal is then passed via a single ended amplifier with unity gain, which results in a signal with twice the magnitude of that of the input. Due to the opposite signs of the outputs of the differential amplifiers, the external interference is canceled out. As the noise factor increases by a marginal factor the signal-to-noise ratio improves. The mixed signal is then fed into two sample-and-hold (S/H) circuits whose timings are controlled such that each circuit samples the signal input to the demodulator during the portion of the signal corresponding to the wavelength to which it responds.

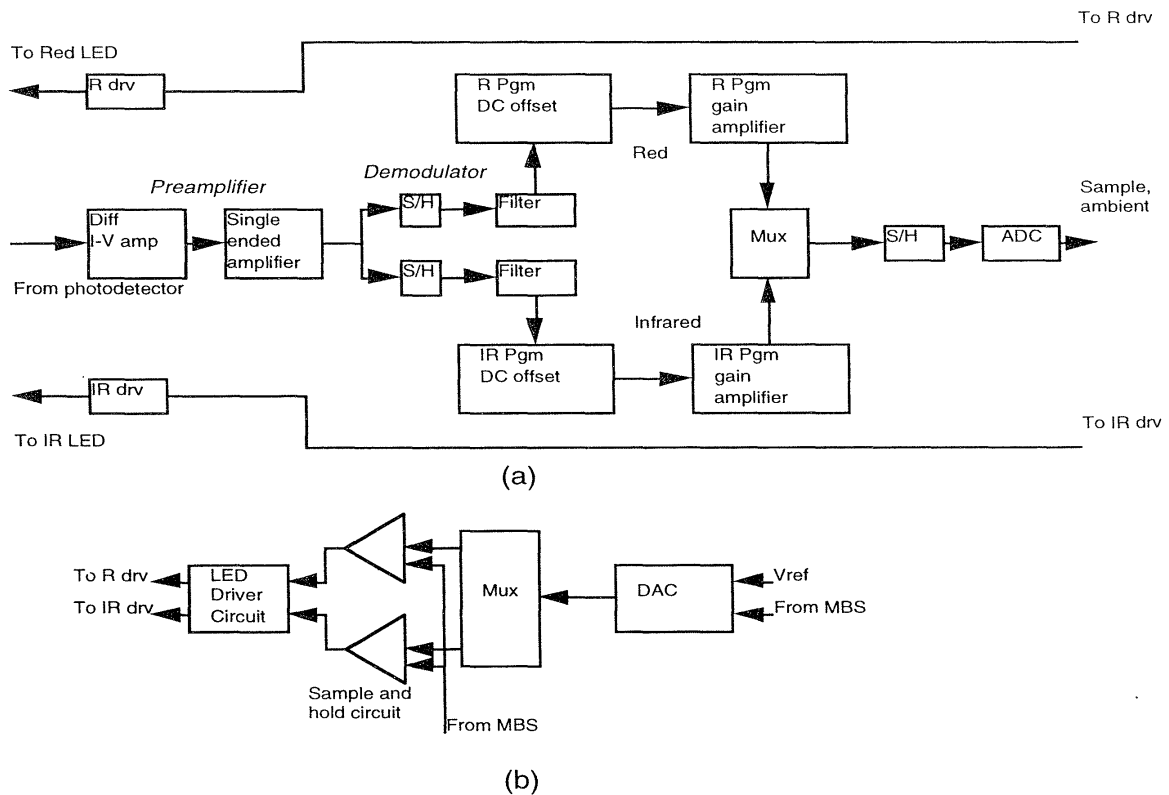

**Figure 8.4** The analog signal flow path along with the signal demodulator and modulator circuit (from Cheung *et al* 1989).

#### 8.4.4 Demodulator and filtering

This section splits the IR and the red signals from the mixed signal from the photodiode. The mixed signal is demultiplexed synchronously and steered depending on the type of signals present. The inputs to this circuit are the photodiode output and the timing or control signal from the MBS. The microprocessor along with the information stored in the EPROM calculates the time period each signal component is present in the photodiode output. Switching at the right time results in the two components getting separated. In order to eliminate the high-frequency switching noise, low-pass filters are provided. To optimize cost, size and accuracy, switched capacitor filters are used. These filters

cause the two signals (red and infrared) to be identical in gain and phase frequency response. In order to filter out the noise generated by this switched capacitor a second filter follows in the cascade to filter out the switching frequency noise. This stage is a high roll-off stage, allowing the first stage to be the dominating one, resulting in higher accuracy. Then using programmable DC offset eliminators and programmable gain amplifiers, the two signals are multiplexed along with other analog signals prior to being fed into an ADC. Offset amplifiers offset the signals by a small positive level. This ensures that the offsets caused by the chain of amplifiers do not allow the signal to be negative as this is the input to the ADC, and the ADC only accepts inputs from 0 to 10 V. Also sometimes the gain of the red or the IR channel may be greater than the other, and therefore the offset must be compensated accordingly.

#### 8.4.5 DC offset elimination

To exploit the entire dynamic range of the ADC the two signals (red and IR) have to be processed further. Before discussing how this processing is done let us examine why this is done.

We know that the mixed signal consists of a pulsatile and a nonpulsatile component. The nonpulsatile component approximates the intensity of the light received at the photodiode when only the absorptive nonpulsatile component is present at the site (finger, earlobe, etc). This component is relatively constant over short periods, but due to probe position variation and physiological changes this component may vary significantly over large intervals. But as we analyze these signals in small interval windows, this is not a major problem. Figure 8.5 shows that this nonpulsatile component may be  $S\_LOW$ , with the difference between  $S\_HIGH$  and  $S\_LOW$  being the varying pulsatile component, due to the arterial pulsations at the site. This pulsatile component is very small compared to the nonpulsatile component. Therefore great care must be taken when determining and eventually analyzing these values, as we desire the pulsatile component.

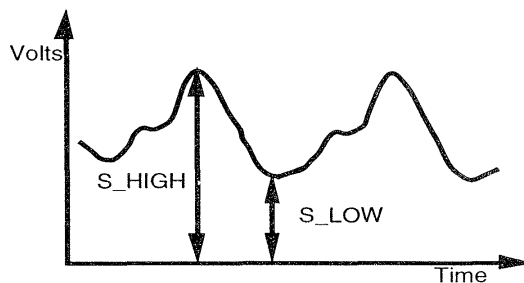

**Figure 8.5** The nature of the signal transmission received by the photodiode circuit.

Amplifying and converting to digital form the substantial nonpulsatile component will use up most of the resolution of the ADC. Therefore in order to exploit the entire dynamic range we must eliminate this component, digitize it and later add it back to the pulsatile component.

For example, consider a ADC having an input range of 0 to 10 V. From figure 8.5 the AC may be 1% of the DC, let  $S\_HIGH = 5.05$  V and  $S\_LOW = 5$  V. For a 12-bit ADC, the resolution of this device is almost  $2^{12}$ . This means that

the total signal is discretized into 4096 levels. Therefore from the above value of the pulsatile component ( $S_{HIGH} - S_{LOW}$ ), we see that only 20 levels are utilized. Therefore if the nonpulsatile component is removed we can use all the 4096 levels, improving the resolution of the ADC.

Cheung *et al* (1989) discuss this concept of nonpulsatile component elimination and addition. The photodiode output contains both the nonpulsatile and the pulsatile component. The programmable subtractors (offset amplifier) remove a substantial offset portion of the nonpulsatile component of each signal and the programmable gain amplifiers increase the gain of the remaining signal for conversion by the ADC. A digital reconstruction of the original signal is then produced by the MBS, which through the use of digital feedback information removes the gain and adds the offset voltages back to the signal.

Feedback from the MBS to the analog and the digital sections of the board is required for maintaining the values for the offset subtraction voltage, gain, and driver currents at levels appropriate for the ADC. Therefore for proper operation, the MBS must continuously analyze and respond to the offset subtraction voltage, gain, and driver currents.

Figure 8.6 shows that thresholds L1 and L2 are slightly below and above the maximum positive and negative excursions L3 and L4 allowable for the ADC input and are established and monitored by the MBS at the ADC. When the signal at the input of the ADC or at the output of the ADC exceeds either of the thresholds L1 or L2, the LED driver currents are readjusted to increase or decrease the intensity of light impinging upon the photodiode. In this manner the ADC is protected from overdrives and the margins between L3, L1, and L2, L4 helps ensure this even for rapidly varying signals. An operable voltage margin for the ADC exists outside the threshold, allowing the ADC to continue operating while the appropriate feedback does the required adjustments.

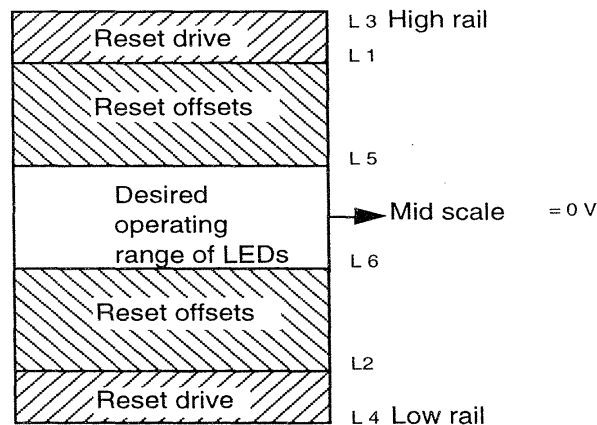

**Figure 8.6** When the signal exceeds thresholds, the LED driver currents are readjusted to prevent overdriving the ADC (from Cheung *et al* 1989).

When the signal for the ADC exceeds the desired operating voltage threshold, L5 and L6, the MBS responds by signaling the programmable subtractor to increase or decrease the offset voltage being subtracted.

The instructions for the MBS program that controls this construction and reconstruction are stored in the erasable, programmable, read-only memory (EPROM).

8.4.6 Timing diagram (Nellcor®)

Figure 8.7 shows that the Nellcor pulse oximeter system uses a four state clock, or has a duty-cycle of 1/4, as compared to a Ohmeda system, where the duty-cycle is 1/3.

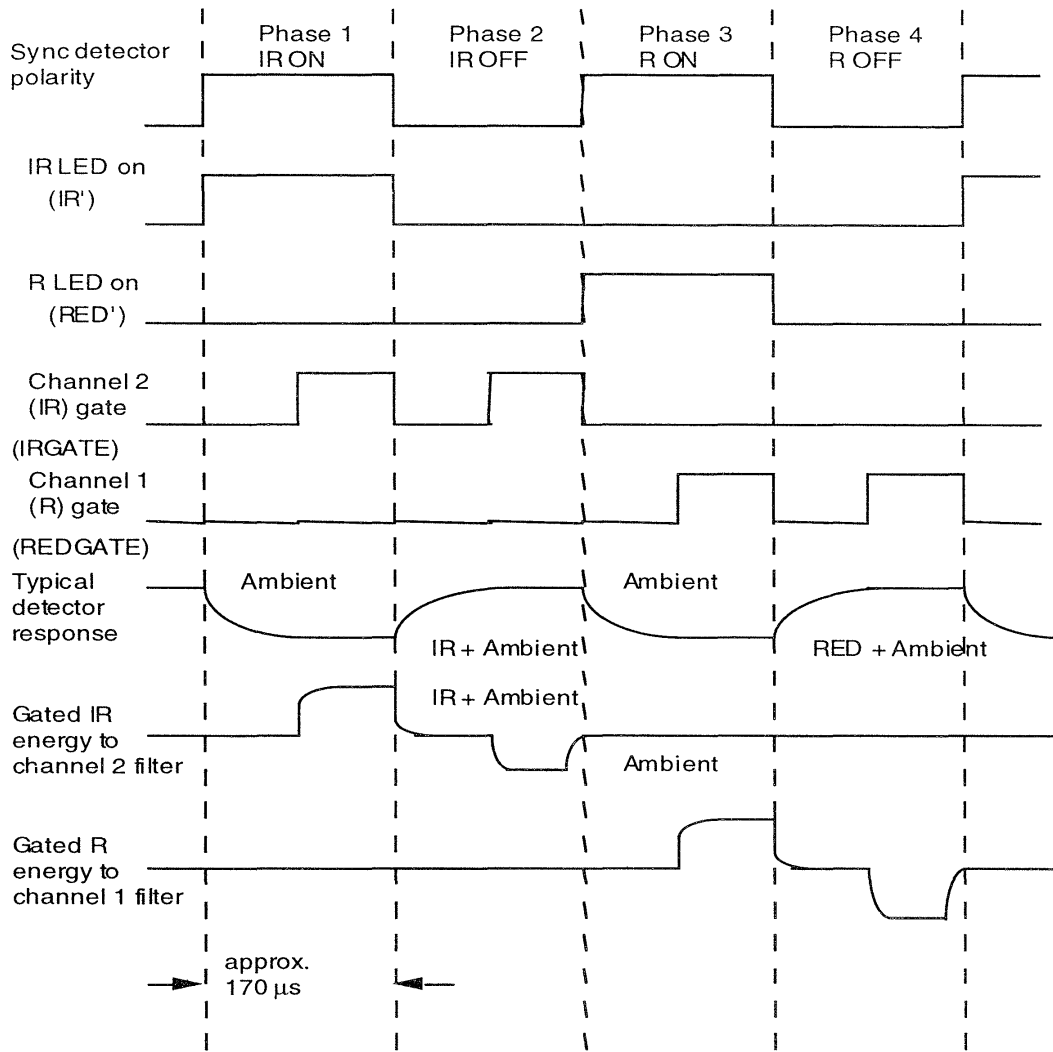

**Figure 8.7** Timing diagram (reprinted with permission from Nellcor, Inc. ©Nellcor, Inc. 1989). Note that the typical detector response is inverted.

In the first quarter the IR LED is on and in the third quarter the R LED is on. In the second and the fourth quarters these LEDs are off. It is during this period that the ambient light measurements are done. The gate pulses are the sampling pulses applied to the input signal to separate out the R and the IR components from the input signal. The sample pulse during the OFF period of the respective LED is used to sample the ambient. The gradual rise or fall is due to the transients, which are smoothed out using low-pass filters. The ambient component is larger in the fourth quarter, compared to the value in the second.

Using suitable values for the gain in the programmable DC offset amplifiers we can eliminate this ambient component. The AC plus the DC components of the R and IR signals are digitized and sent to the MBS.

#### 8.4.7 LED driver circuit

The need to drive both LEDs at different intensities requires analog switches that are used for gating the separate drive voltages. The factor that influences the amount of drive voltage necessary is the signal level from the photodiode and this value is set by the sample-and-hold section. The necessary control signals come from the pattern generator. The main purpose of this drive circuit is to convert this drive voltage to drive current.

Figure 8.8 shows the drive voltages VIR and VR and gating signals IR' and R'. These signals are used to multiplex the two signals back into one, and are fed into a voltage-to-current ( $V-I$ ) converter such that the output of this  $V-I$  converter is a bipolar current signal, that is used to light up only one LED at a time. As the two LEDs are tied in a back to back configuration, this bipolar current drive ensures that only one LED is on at a time.

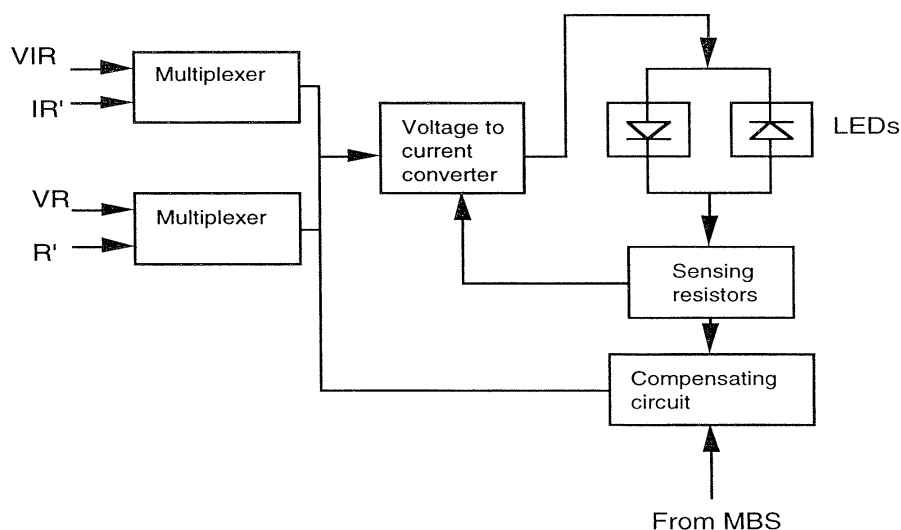

**Figure 8.8** LED driver circuit with the sensor resistors to monitor and control the amount of current into the LED (adapted from Nellcor N-200<sup>®</sup> (Nellcor 1989)).

The drive current requires a control to convert the specified voltage to the proportional drive current. Within the voltage to current converter is an error amplifier that compares the voltage from the current sensing resistors with the specified voltage. There are two bridge networks with current boosters and drive and steering transistors which steer current around this conversion network. The drive output is connected to a pair of parallel back-to-back IR/R LEDs. The current through the LEDs is determined by a sensing resistor and fed back to the error amplifier to maintain a constant current proportional to the desired output voltage and to be independent of the other voltages present across the bridge circuit. Maximum LED current at 25% duty cycle is approximately 120 mA. The back-to-back configuration is such that when one LED is forward biased the

other is not. Chapter 5 describes the LED driver circuit used in the Nellcor® system.

#### 8.4.8 Analog processing system (Ohmeda®)

The main block diagram indicated how different signals on board a pulse oximeter system flow, and showed the signal transfer from one major block (for e.g. ECG, probe, MBS, power supply, etc) to the other. This section will elaborate on the analog signal flow from the photodiode output until the analog signal is ready to drive the LEDs to make another measurement. See figure 8.9.

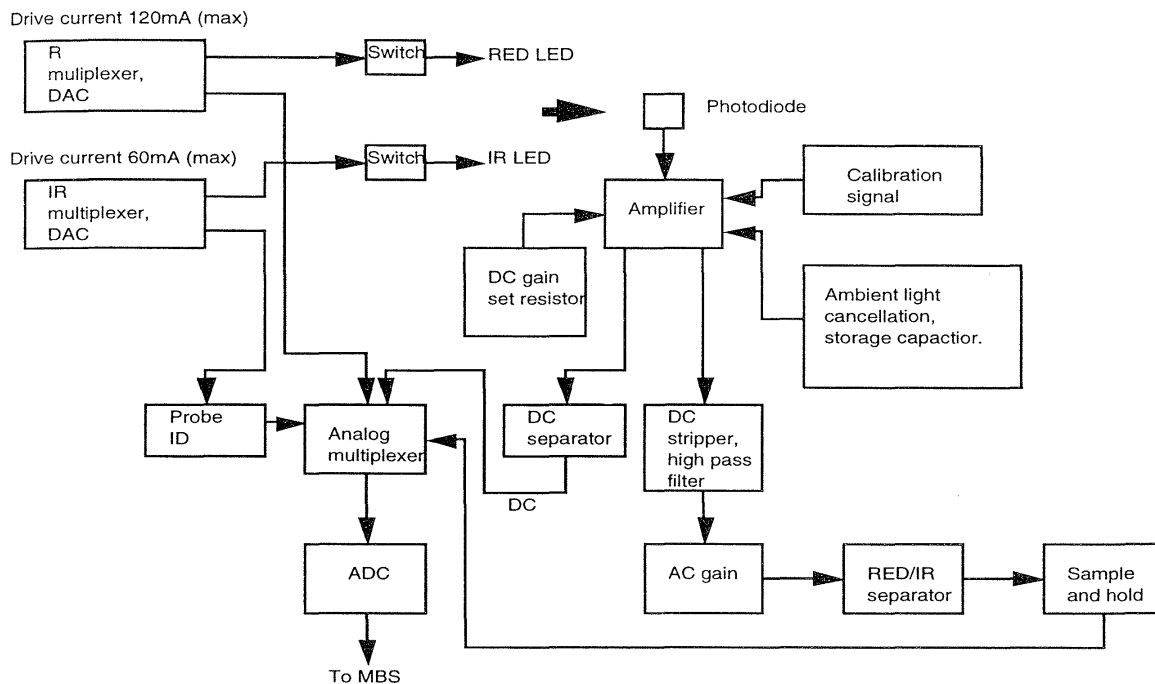

**Figure 8.9** Functional block diagram of the pulse oximeter system showing all the main blocks involved in analog signal processing (adapted from Ohmeda 3740® (Ohmeda 1988)).

**8.4.8.1 LED drive and monitor.** The probe consists of the LEDs and the photodiode. The currents through the LEDs are controlled by a pair of multiplexers and switches and digital-to-analog converters (DACs). The maximum drive current is 120 mA through the R LED and 60 mA through the IR LED. The multiplexer and the switch turn the R and the IR LED drive on and off. The timing signal from the MBS controls the switches. The duty cycle of this timing signal is approximately 1/3 (Note that the duty cycle in devices from Nellcor® is 1/4). Therefore the subsequent hardware and analog and digital signal processing is different. The notable differences are in the multiplexers and sample and hold circuit. In the Ohmeda version, as the duty cycle is 1/3, first the R, then the IR, and finally the ambient component (measured when both the R and IR LEDs are off), are separated. In the Nellcor version as the duty cycle is 1/4 (see figure 8.7), the ambient component is measured twice.

The LED drive currents are monitored by switches and capacitors when both the R and IR LEDs are on individually and when both of them are off.



*8.4.8.2 Calibration test signal.* The signal received by the photodiode contains information on the AC and DC components of the pulsatile arterial blood flow measured by both the R and IR LEDs and also the ambient light component which is measured when both the R and IR LEDs are off. The calibration signal is a test signal injected into the signal path. The calibration signal is used to emulate the photodiode amplifier output which represents a known oxygen concentration and pulse rate of 150 to 210 beats per minute. The MBS checks the calibration of the oximeter by setting a test signal. This selects the calibration signal to be passed through the switch of the multiplexer in place of the photodiode amplifier output.

*8.4.8.3 Ambient light cancellation.* Ambient light cancellation is done to remove the effects of ambient light from the photodiode signal. A capacitor and a switch of a multiplexer are used to first charge up this capacitor to a voltage difference between the input signal and ground, when the input signal contains only the ambient component (R and IR LEDs are off). After this phase this voltage is subtracted from the input signal, now containing the R and IR components.

*8.4.8.4 DC gain set resistor.* The DC gain of the input signal is set under the control of the MBS. One resistor from a resistor bank is selected and along with another fixed resistor is used to set the gain of the amplifier.

*8.4.8.5 DC separator.* This block separates the DC components of the R and IR signals. This section consists of multiplexers and low-pass filters. The switches, controlled by the MBS, allow the red or the infrared component of the signal to pass through the low-pass filter. A set of amplifiers amplifies this DC before it is sent into the analog-to-digital (ADC) converter for conversion before being fed into the MBS. As a result of this stage we obtain the DC components of the R and the IR signals.

*8.4.8.6 Low-pass filtering and DC stripping.* A switched capacitor low-pass filter is used in this section. Since the DC components have been separated and measured previously, it is not necessary to filter during the ambient time. The R and IR components are low-pass filtered during the R and IR time.

DC stripping is used to separate the pulsatile component from the signal. The low-passed signal is sent via a high-pass switching filter, and depending on the R and IR LED times, the pulsatile or the AC components of the R and IR signals are generated. This stage yields the AC components of the R and the IR signals.

*8.4.8.7 Red/infrared separator.* Multiplexers separate the red and infrared pulsatile signals into two independent channels. Low-pass filters are also used to smooth the separated signals. To compensate for the gain differences between the red and infrared signal paths, the gain of the infrared amplifier is adjustable by potentiometer.

*8.4.8.8 Sample and hold circuits.* Sample and hold circuits sample the red and infrared pulsatile signals simultaneously so that they can be measured by the ADC. An additional sampling signal controls the timing of the sampling of the pulsatile components at a rate synchronous to the power line frequency. This sampling frequency helps to suppress interference generated from sources connected to the line power.

**8.4.8.9 Probe identification.** This is the voltage generated by passing a known amount of current through the probe coding resistor to identify the wavelengths associated with the probe. This signal is digitized, compared to a lookup table in the MBS's memory, and the associated wavelength values are used for further processing.

An analog multiplexer is used to choose one of the many inputs and feed it to the ADC. The MBS for the Ohmeda system is similar to the one used in Nellcor, but uses Zilog's Z-8002. Motion artifact elimination using the R wave (ECG synchronization), as seen in Nellcor N-200 is not present in this system.

**8.4.8.10 Timing diagram.** In the Ohmeda Biox 3700® oximeter the LED on-off cycle is repeated at a rate of 480 Hz (figure 8.10). This cycling allows the oximeter to know which LED is on at any instant of time (Pologe 1987). The duty cycle in this system is 1/3. The red LED is on for the first 1/3 of the cycle, the infrared LED is on for the second 1/3 and both LEDs are off for the third 1/3, allowing for the ambient light measurements. This kind of measurement of ambient light is necessary so that it can be subtracted from the levels obtained when the LEDs are on.

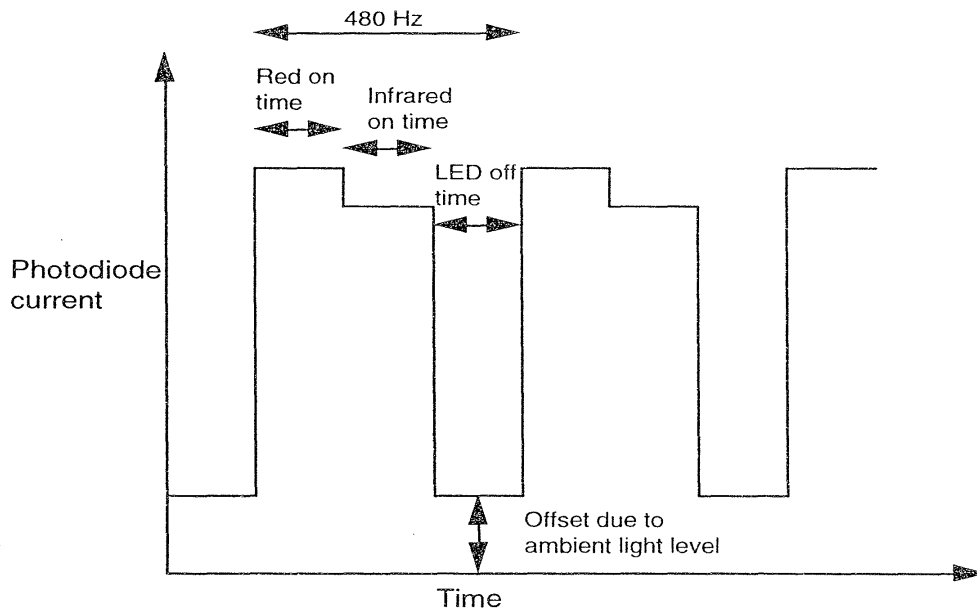

**Figure 8.10** Output of the photodiode of the pulse oximeter system (adapted from Ohmeda 3700® (Ohmeda 1988)).

## 8.5 ECG SECTION

Pulse oximeters use the ECG to eliminate disturbances caused by motion artifacts and ambient light. There is a time delay between the electrical and the mechanical activity of the heart. When an ECG QRS electrical complex is detected, a mechanical pulse will be detected at the sensor after a transit delay of about 100 ms. This delay depends on factors such as the heart rate, the compliance of the

arteries, and the distance of the probe from the heart. The pulse oximeter computes this delay and stores it, and an average delay is generated after a few pulses. This average delay is used to establish a time window, during which the pulse is expected at the probe site. So if a pulse is received within this time window, it is treated as real and is processed. Any pulse arriving outside this window is simply rejected. Note that the time averaging and the time window are constantly updated to account for the patient's physiological changes.

### *8.5.1 Active filters*

Figure 8.11 shows that the ECG signal from the patient has to pass through a series of filters before it is used for processing. Usually these filter stages provide gain, as the signal level received is very small. The most commonly used filters are as follows.

1. A low-pass filter with a corner frequency of 40 Hz.
2. A switched capacitor notch filter at the power line frequency. The capacitor switching frequency is determined by the timer pulse, which is in turn set by the microprocessor. The microprocessor along with its associated circuitry determines the power line frequency, and accordingly sets the notch frequency.
3. A second 40 Hz low-pass filter may be used to filter out the transients generated by the capacitor switching.
4. A high-pass filter, with a corner frequency of 0.5 Hz, is used for the lower end of the range. This filter has a substantial gain and has a long time constant. The reset condition discharges this capacitor. The most common situations desiring a reset are the lead fall off condition, muscle contraction under the electrode, or a sudden shift in the baseline of the ECG, due to the already high combined gain due to the front end section and the filters preceding this stage.

When pulse oximeters are used in electromagnetic environments (MRI 1992), such as magnetic resonance imaging (MRI), special care has to be taken, as EMI interferences are quite disturbing for pulse oximeters. Probes and connectors are shielded, using faraday cages, and additional EMI elimination filters are incorporated in the pulse oximeter (see chapter 11).

### *8.5.2 Offset amplifiers*

Analog-to-digital converters have a specified input dynamic range for obtaining the maximum digitized output. Usually these are in the positive range, from 0 to 5 or 0 to 10 V. Therefore an amplifier that can offset the analog signals to a value beyond 0 V and convert its peak value to 5 to 10 V is needed. For example if there is a signal from  $-0.7$  V to  $+6.7$  V and an ADC with dynamic range of 0 to 5 V, the offset amplifier will convert this range to 0 to 5 V. Then we can make use of the entire resolution of the ADC.

### *8.5.3 Detached lead indicator*

ECG signals are sensed by the electrodes placed on the body and the signals are transferred from the site to the pulse oximeter via leads. If the electrode falls off

from the surface of the body, the pulse oximeter's front end display must indicate this. The indicator system consists of a voltage comparator, absolute value circuit and a latching flip flop. This stage examines the ECG signal at the input to the switched capacitor notch filter (60 Hz), after it has passed through the low-pass stage preceding it. There is a biasing resistor network that drives the ECG signal to either  $\pm 15$  V, if one or more ECG leads are detached from the patient's body. If the signal rails to  $-15$  V, it is converted to positive voltage by a level shifter amplifier. Using this signal, the data are latched in a flip flop and the processor is notified that a lead has fallen off. After the processor recognizes this, it resets this latching flip flop so it is now ready to sense any other fall off.

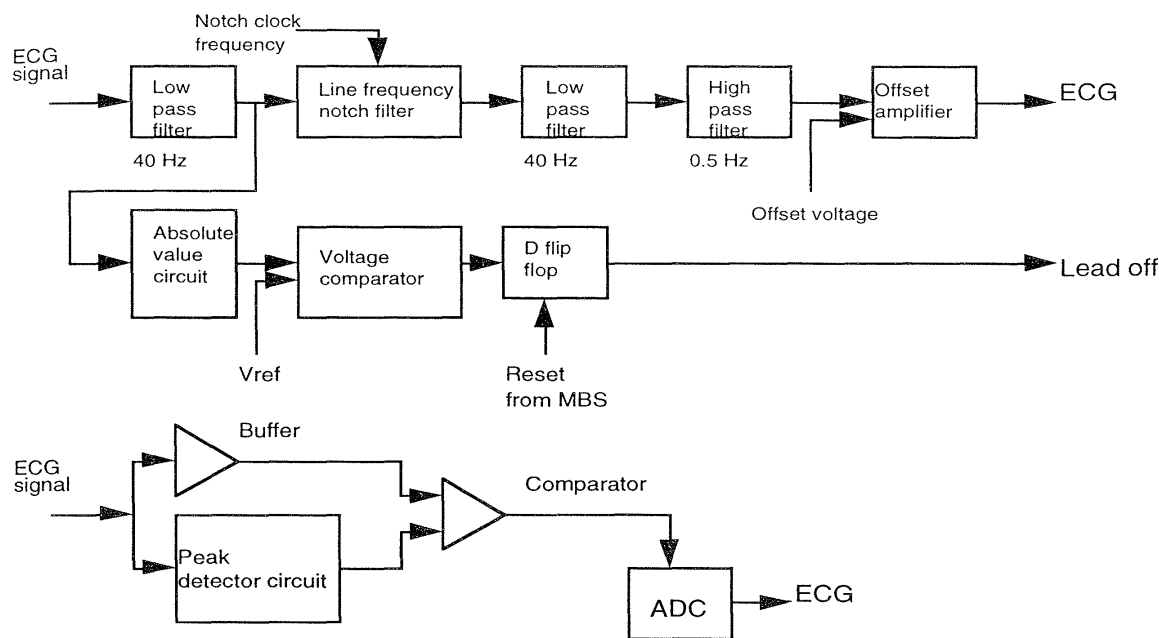

**Figure 8.11** ECG signal processing section along with the lead fall off indicator and peak detector unit (adapted from Nellcor N-3000<sup>®</sup> (Nellcor 1991)).

#### 8.5.4 Power line frequency sensing

Electric devices usually have the main power ac signal transformed to a root mean square value for power line analysis. A voltage comparator is used to generate a signal that interrupts the microprocessor at the frequency of the ac power line. This signal is then used to set the notch filter at the line frequency to eliminate the line frequencies. Most devices have provision for a 50 Hz or 60 Hz line.

#### 8.5.5 ECG output

This section is used to generate pulses to synchronize the processor with the R-wave arrival. There is a peak follower circuit that stores the peak R-wave pulse in a slowly decaying fashion. This is employed to ensure that the capacitor doesn't discharge before the next R wave arrives. An adjustable threshold is provided for sensing each R-wave peak. This parameter is set by the processor, which in turn

is influenced by many external parameters. A voltage comparator produces a high output whenever the ECG input exceeds the adjustable threshold determined by the previous R-wave peak.

## 8.6 SIGNAL CONVERSION

The signal conversion unit consists of an ADC or DAC. Signals have dc offsets subtracted and even amplified before processing. This enables us to extract signals having low modulation and riding on a high DC, and this helps improve the response time of the system.

### 8.6.1 Analog-to-digital conversion technique

Analog-to-digital conversion on the processor board is accomplished by using a sample-and-hold circuit, which holds a voltage until it is sampled by a routine written in the memory of the processor. Both software and hardware play a important role in the conversion.

Figure 8.12 shows that first the processor writes to an analog multiplexer to select one of its several analog inputs that desire digital conversion. These signals could be the demultiplexed and filtered IR or the red photodiode channel signal, the filtered ECG waveform, or filtered voltage from the coding resistor. The selected signal is first latched and the analog circuitry is notified of the amplitude level. This helps to set the gain of the programmable amplifiers, so that the voltages at the input of the ADC do not exceed the maximum range. This ensures that the entire range of the ADC is used. A sample is generated by the processor to trigger the sample-and-hold circuit. This causes the sample-and-hold chip to hold the current channel for conversion. The processor begins executing the appropriate software for conversion. Usually the conversion routine adopted is the successive approximation routine (SAR). In this system, the SAR performs a binary check, by setting up a voltage using the DAC, which is compared to the currently held voltage signal via a comparator. The result of this comparison is polled by the processor. This process continues till the least significant bit is converted. Usually a 12-bit conversion is done in approximately 100  $\mu$ s.

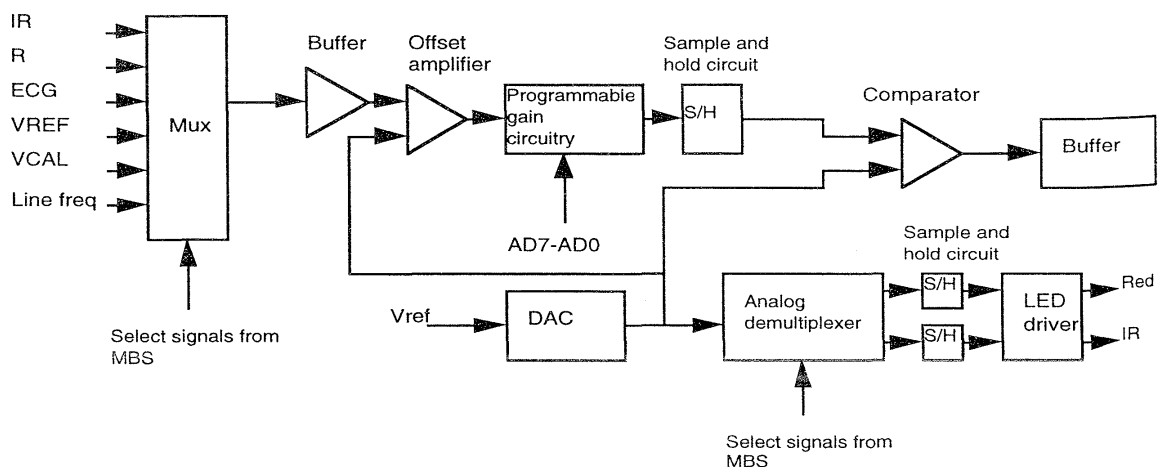

**Figure 8.12** Generic analog-to-digital conversion circuit.

### 8.6.2 Digital-to-analog conversion

This is used to aid in digitizing the voltage at the ADC input, using the SAR. The DAC also has the following important application. The DACs have analog sample-and-hold circuits which are made using the analog demultiplexers and a series of variable gain amplifiers. Usually a DAC is used to update and store signals like the IR/red LED brightness control, or the speaker volume control. The analog signals are routed using the microprocessor. The processor puts out the analog voltage to the analog demultiplexer using the DAC. The processor selects which output will be written, using the address lines.

### 8.6.3 Sample-and-hold circuit

The analog conversion circuitry contains an  $n$ -bit DAC, a 1-to-8 bus-compatible analog multiplexer, switches for selecting the full scale analog output voltage range, and the analog sample-and-hold network. The DAC puts out an address of the task to be sampled and this information is decoded by the analog multiplexer and the desired sample-and-hold circuit is selected.

The sample-and-hold circuit is made up of storage capacitors and unity gain amplifiers. These amplifiers are usually the FET high-input-impedance devices. These circuits are protected via zener diodes that are needed to eliminate the short lived voltage transients. As we are driving high capacitive loads we need resistances to minimize these transients.

## 8.7 TIMING AND CONTROL

The time required to access a memory or an external device is as important as controlling the various instruction executions within a microprocessor subsystem. The microprocessor adopts two techniques for the timing control. These are the polled processor I/O signal and the processor interrupts.

### 8.7.1 Polling and interrupt

In the polling technique the microprocessor has a signal that constantly polls or scans the various input waiting for a response. As soon as a valid signal is received at the polled input, the microprocessor starts the required task execution.

In the interrupt technique, the various chips and the inputs on the system are tied to the microprocessor via dedicated input lines. These lines are asserted high when a device requests help from the microprocessor. The microprocessor interrupts its current functionality and starts executing the interrupt routine. In the case of important activities these interrupt lines could be masked. Inputs may be provided with priority interrupt levels. When two or more interrupts are initiated at the same time, the higher priority interrupt performs first. Nested processing is done, in which within one interrupt execution another interrupt request can be answered.

For example, while the oxygen saturation is being measured along with the ECG signal, if there is a lead fall off situation, in which the device loses the ECG signal, a number of processes have to be initiated. First of all, the program in progress, calculating the oxygen saturation using the calibration tables has to be