



US 20030065269A1

(19) **United States**

(12) **Patent Application Publication** (10) **Pub. No.: US 2003/0065269 A1**

Vetter et al.

(43) **Pub. Date: Apr. 3, 2003**

(54) **METHOD AND DEVICE FOR PULSE RATE DETECTION**

(52) **U.S. Cl. 600/503**

(75) **Inventors: Rolf Vetter, Yverdon (CH); Philippe Renevey, Lausanne (CH); Roland Gentsch, Hauterive (CH); Jens Krauss, Neuchatel (CH); Yves Depeursinge, Servion (CH)**

(57) **ABSTRACT**

Correspondence Address:
PARKHURST & WENDEL, L.L.P.
1421 PRINCE STREET
SUITE 210
ALEXANDRIA, VA 22314-2805 (US)

There is described a device and a method for detecting the pulse rate. The measuring principle consists of emitting radiant energy at the surface of or through human body tissue (5) by means of a light-emitting source (10), measuring the intensity of the radiant energy after propagation through the human body tissue by means of at least first and second light detectors (21, 22, 23, 24) located at a determined distance from the light-emitting source and providing first and second input signals ($y_1(t)$, $y_2(t)$) representative of this propagation. Simultaneously, a motion detecting device (40), such as a three dimensional accelerometers, provides a motion reference signal ($a_x(t)$, $a_y(t)$, $a_z(t)$) representative of motion of the detecting device on and with respect to the human body tissue (5). The input signals are then processed in order to remove motion-related contributions due to motion of the detecting device (1) on and with respect to the human body tissue (5) and to produce first and second enhanced signals. This processing basically comprises the elaboration of a model of the motion-related contributions based on the motion reference signal and the subtraction of this model from each of the input signals. Pulse rate is then extracted from the enhanced signals using for instance a maximum likelihood histogram clustering technique.

(73) **Assignee: CSEM Centre Suisse d'Electronique et de Microtechnique SA, Neuchatel (CH)**

(21) **Appl. No.: 10/255,068**

(22) **Filed: Sep. 26, 2002**

(30) **Foreign Application Priority Data**

Sep. 28, 2001 (EP) 01203686.9

Publication Classification

(51) **Int. Cl.⁷ A61B 5/02**

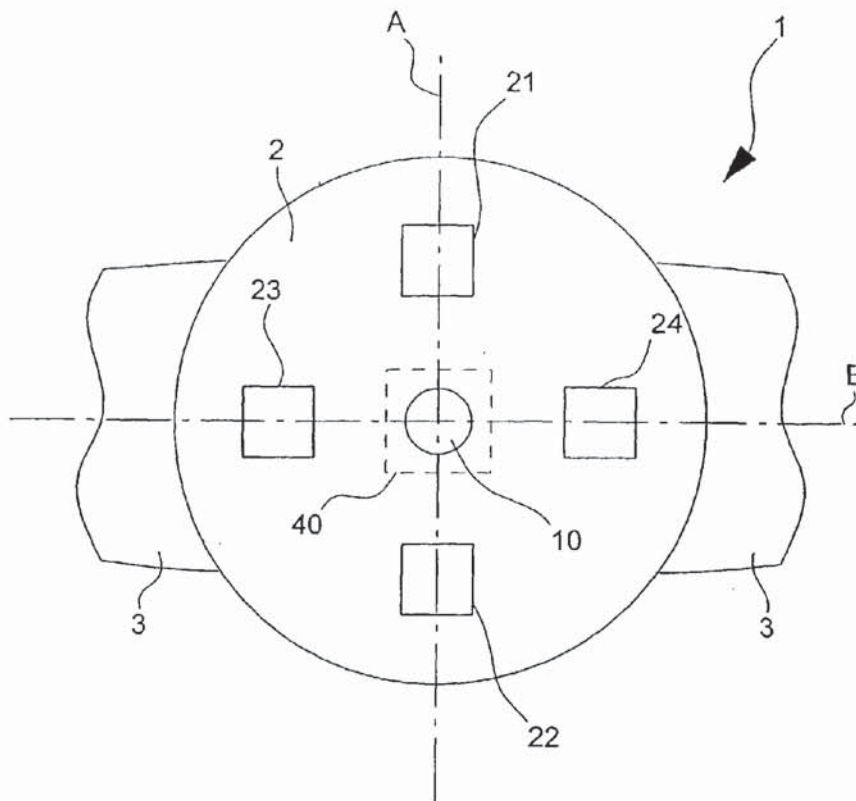

Fig.1

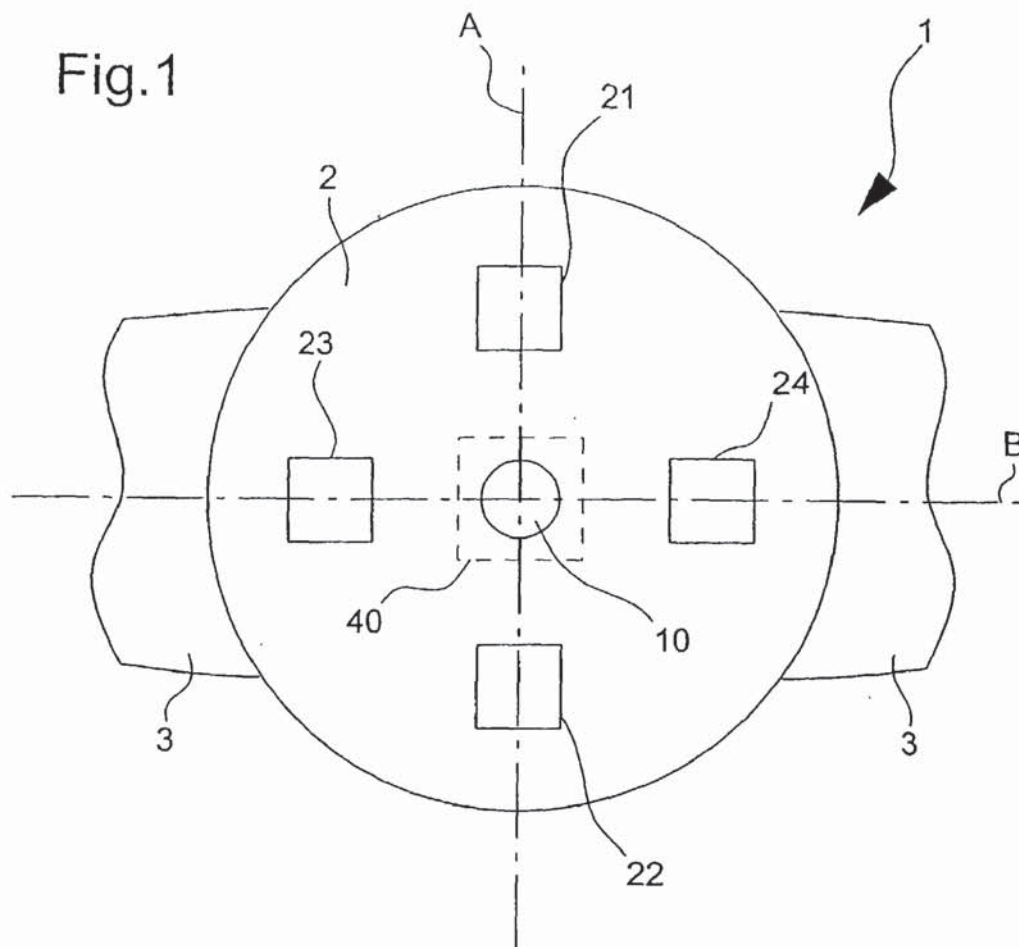

Fig.2

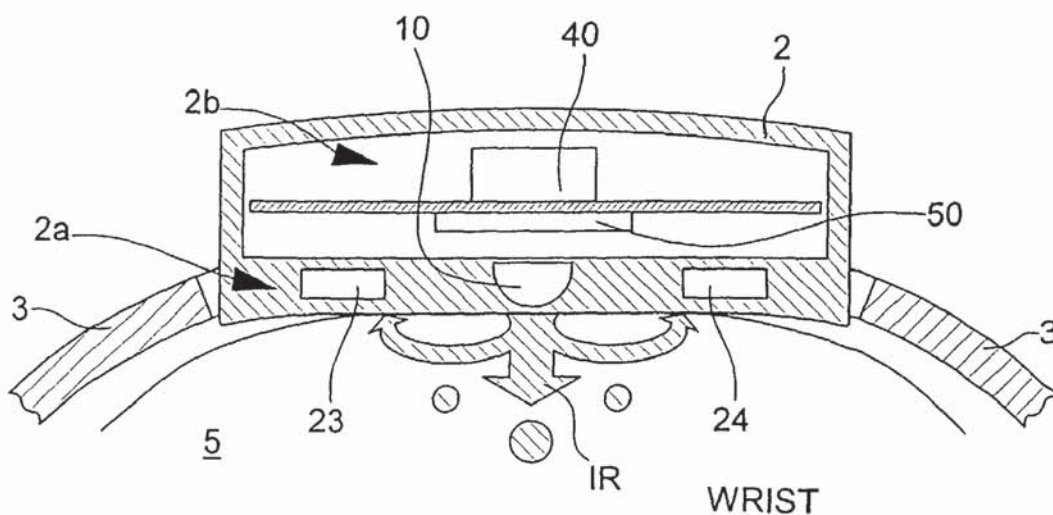
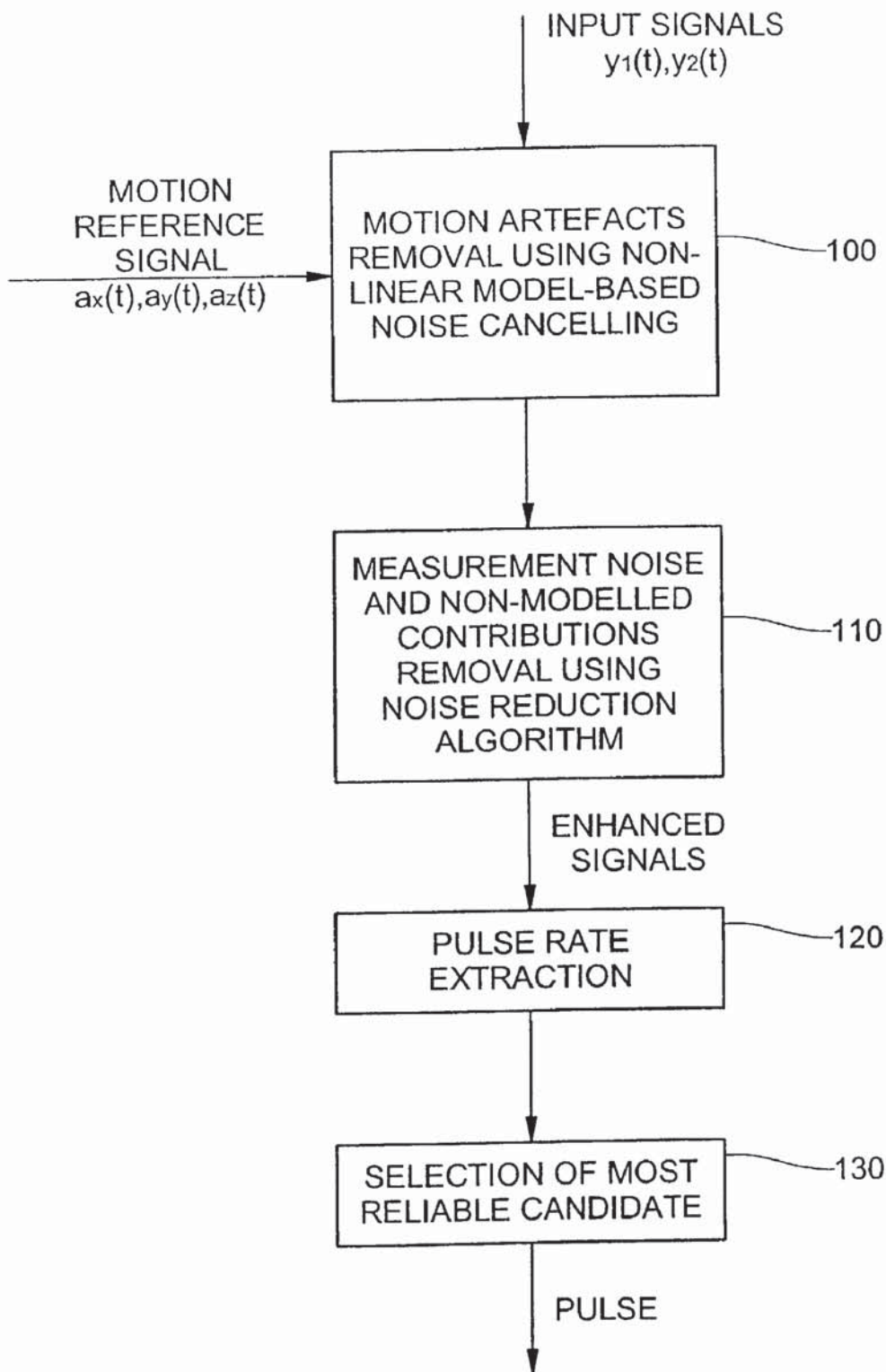

Fig.3



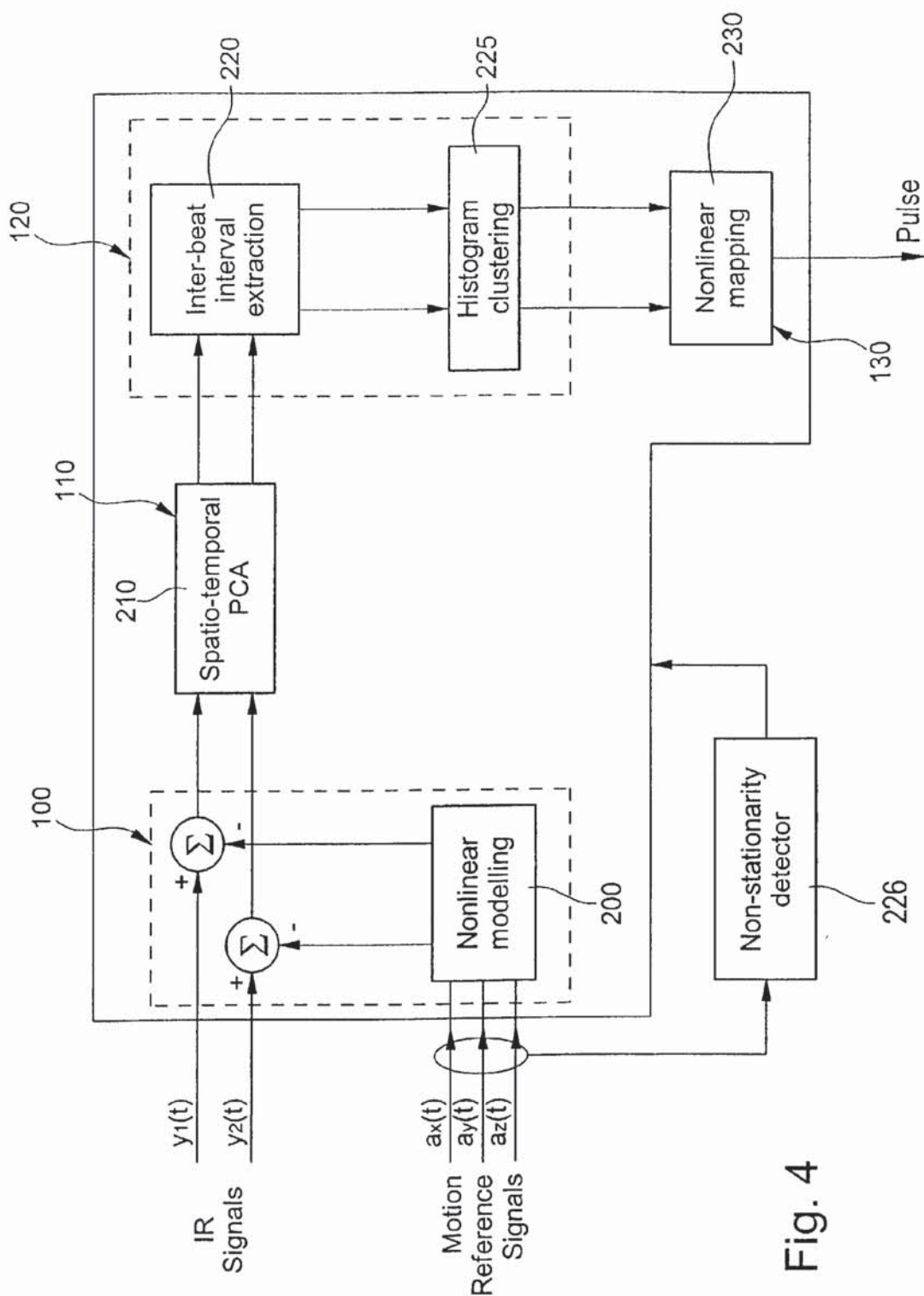

Fig. 4

Fig. 5a

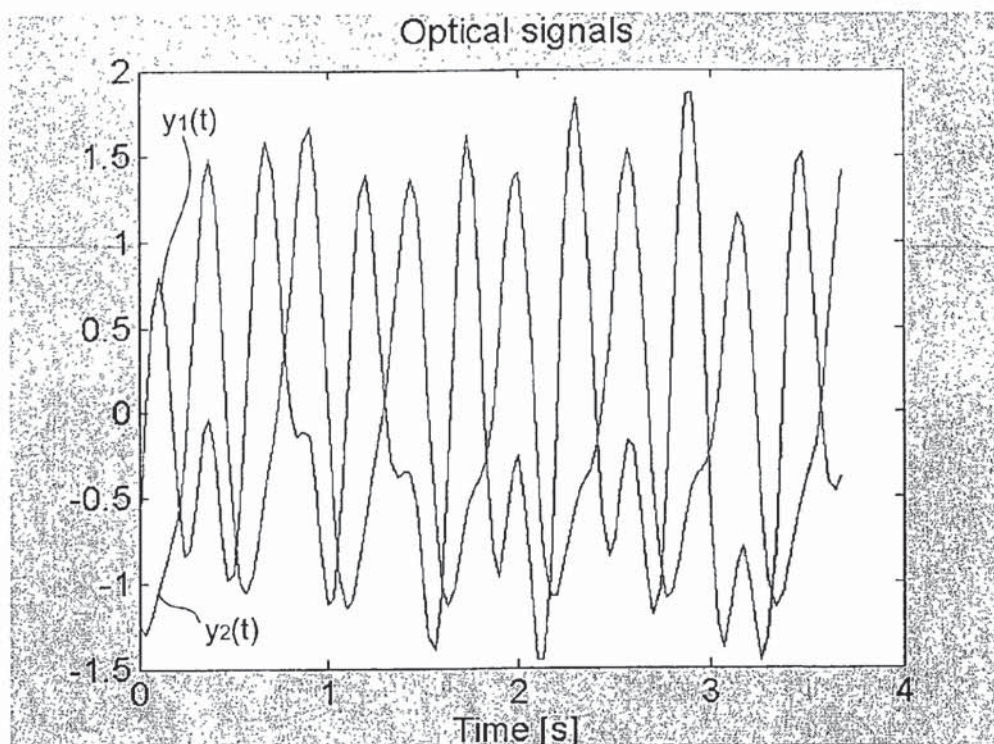
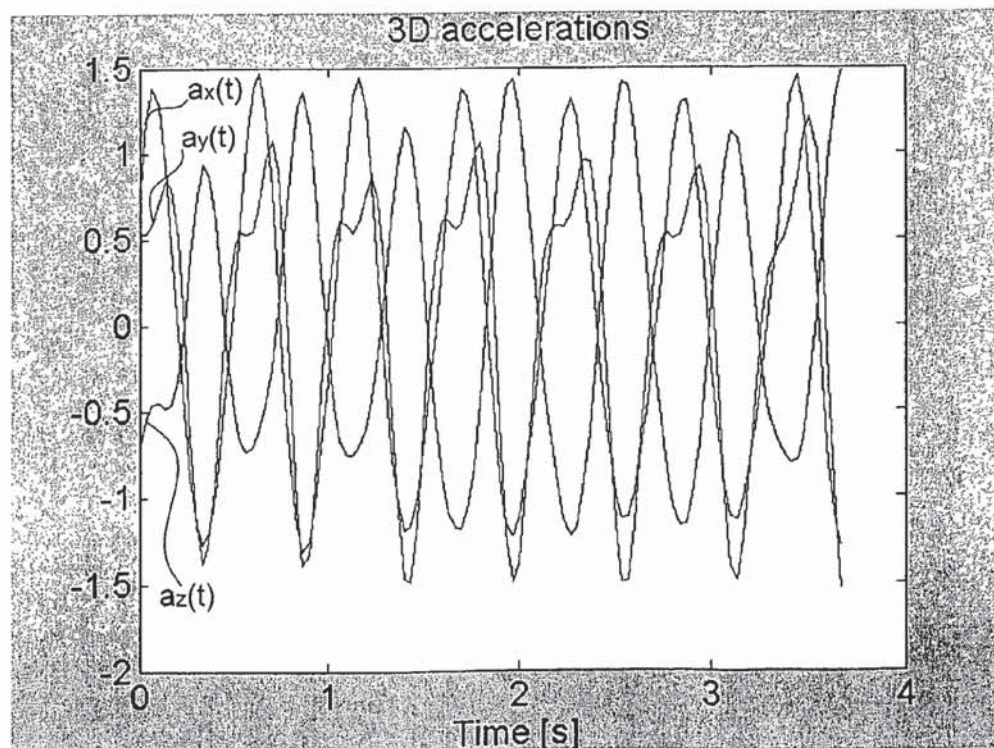

Fig. 5b



Explore Litigation Insights

Docket Alarm provides insights to develop a more informed litigation strategy and the peace of mind of knowing you're on top of things.

Real-Time Litigation Alerts



Keep your litigation team up-to-date with **real-time alerts** and advanced team management tools built for the enterprise, all while greatly reducing PACER spend.

Our comprehensive service means we can handle Federal, State, and Administrative courts across the country.

Advanced Docket Research



With over 230 million records, Docket Alarm's cloud-native docket research platform finds what other services can't. Coverage includes Federal, State, plus PTAB, TTAB, ITC and NLRB decisions, all in one place.

Identify arguments that have been successful in the past with full text, pinpoint searching. Link to case law cited within any court document via Fastcase.

Analytics At Your Fingertips



Learn what happened the last time a particular judge, opposing counsel or company faced cases similar to yours.

Advanced out-of-the-box PTAB and TTAB analytics are always at your fingertips.

API

Docket Alarm offers a powerful API (application programming interface) to developers that want to integrate case filings into their apps.

LAW FIRMS

Build custom dashboards for your attorneys and clients with live data direct from the court.

Automate many repetitive legal tasks like conflict checks, document management, and marketing.

FINANCIAL INSTITUTIONS

Litigation and bankruptcy checks for companies and debtors.

E-DISCOVERY AND LEGAL VENDORS

Sync your system to PACER to automate legal marketing.