

Under the Paperwork Reduction Act of 1995 no persons are required to respond to a collection of information unless it displays a valid OMB control number

<b>UTILITY                  PATENT APPLICATION                  TRANSMITTAL</b>  <i>(Only for new nonprovisional applications under 37 CFR 1.53(b))</i>	Attorney Docket No.	9653-7TSCT2
	First Named Inventor	Steven Francis LeBoeuf
	Title	Methods and Apparatus for Generating Data Strings...
	Express Mail Label No.	

<b>APPLICATION ELEMENTS</b> <i>See MPEP chapter 600 concerning utility patent application contents.</i>	<b>ADDRESS TO:</b> Commissioner for Patents P.O. Box 1450 Alexandria, VA 22313-1450
--	--

1.  Fee Transmittal Form (PTO/SB/17 or equivalent)
2.  Applicant asserts small entity status. See 37 CFR 1.27
3.  Applicant certifies micro entity status. See 37 CFR 1.29. Applicant must attach form PTO/SB/15A or B or equivalent.
4.  Specification [Total Pages 51] Both the claims and abstract must start on a new page. (See MPEP § 608.01(a) for information on the preferred arrangement)
5.  Drawing(s) (35 U.S.C. 113) [Total Sheets 21]
6.  Inventor's Oath or Declaration [Total Pages \_\_\_\_\_] (Including substitute statements under 37 CFR 1.64 and assignments serving as an oath or declaration under 37 CFR 1.63(e))
  - a.  Newly executed (original or copy)
  - b.  A copy from a prior application (37 CFR 1.63(d))
7.  Application Data Sheet \* See note below. See 37 CFR 1.76 (PTO/AIA/14 or equivalent)
8.  CD-ROM or CD-R in duplicate, large table, or Computer Program (Appendix)
  - Landscape Table on CD
9.  Nucleotide and/or Amino Acid Sequence Submission (if applicable, items a. - c. are required)
  - a.  Computer Readable Form (CRF)
  - b.  Specification Sequence Listing on:
    - i.  CD-ROM or CD-R (2 copies); or
    - ii.  Paper
  - c.  Statements verifying identity of above copies

**ACCOMPANYING APPLICATION PAPERS**

10.  Assignment Papers (cover sheet & document(s))  
Name of Assignee \_\_\_\_\_
11.  37 CFR 3.73(c) Statement (when there is an assignee)  Power of Attorney
12.  English Translation Document (if applicable)
13.  Information Disclosure Statement (PTO/SB/08 or PTO-1449)
  - Copies of citations attached
14.  Preliminary Amendment
15.  Return Receipt Postcard (MPEP § 503) (Should be specifically itemized)
16.  Certified Copy of Priority Document(s) (if foreign priority is claimed)
17.  Nonpublication Request Under 35 U.S.C. 122(b)(2)(B)(i). Applicant must attach form PTO/SB/35 or equivalent.
18.  Other: \_\_\_\_\_

**\*Note:** (1) Benefit claims under 37 CFR 1.78 and foreign priority claims under 1.55 must be included in an Application Data Sheet (ADS).  
 (2) For applications filed under 35 U.S.C. 111, the application must contain an ADS specifying the applicant if the applicant is an assignee, person to whom the inventor is under an obligation to assign, or person who otherwise shows sufficient proprietary interest in the matter. See 37 CFR 1.46(b).

**19. CORRESPONDENCE ADDRESS**

The address associated with Customer Number: 20792 OR  Correspondence address below

Name			
Address			
City	State	Zip Code	
Country	Telephone	Email	
Signature	<i>Needham J. Boddie II</i>		Date
Name (Print/Type)	Needham J. Boddie, II		Registration No. (Attorney/Agent)
			February 19, 2014
			40,519

This collection of information is required by 37 CFR 1.53(b). The information is required to obtain or retain a benefit by the public which is to file (and by the USPTO to process) an application. Confidentiality is governed by 35 U.S.C. 122 and 37 CFR 1.11 and 1.14. This collection is estimated to take 12 minutes to complete, including gathering, preparing, and submitting the completed application form to the USPTO. Time will vary depending upon the individual case. Any comments on the amount of time you require to complete this form and/or suggestions for reducing this burden, should be sent to the Chief Information Officer, U.S. Patent and Trademark Office, U.S. Department of Commerce, P.O. Box 1450, Alexandria, VA 22313-1450. DO NOT SEND FEES OR COMPLETED FORMS TO THIS ADDRESS. SEND TO: Commissioner for Patents, P.O. Box 1450, Alexandria, VA 22313-1450.

*If you need assistance in completing the form, call 1-800-PTO-9199 and select option 2.*

Apple Inc.  
APL1002

U.S. Patent No. 8,923,941

Under the Paperwork Reduction Act of 1995, no persons are required to respond to a collection of information unless it contains a valid OMB control number.

<b>Application Data Sheet 37 CFR 1.76</b>		Attorney Docket Number	9653-7TSCT2
		Application Number	
Title of Invention	METHODS AND APPARATUS FOR GENERATING DATA STRINGS CONTAINING PHYSIOLOGICAL AND MOTION-RELATED INFORMATION		
<p>The application data sheet is part of the provisional or nonprovisional application for which it is being submitted. The following form contains the bibliographic data arranged in a format specified by the United States Patent and Trademark Office as outlined in 37 CFR 1.76.          This document may be completed electronically and submitted to the Office in electronic format using the Electronic Filing System (EFS) or the document may be printed and included in a paper filed application.</p>			

### Secrecy Order 37 CFR 5.2

Portions or all of the application associated with this Application Data Sheet may fall under a Secrecy Order pursuant to 37 CFR 5.2 (Paper filers only. Applications that fall under Secrecy Order may not be filed electronically.)

### Inventor Information:

<b>Inventor 1</b> <span style="float: right;">Remove</span>					
<b>Legal Name</b>					
<b>Prefix</b>	<b>Given Name</b>	<b>Middle Name</b>	<b>Family Name</b>	<b>Suffix</b>	
	Steven	Francis	LeBoeuf		
<b>Residence Information (Select One)</b> <input checked="" type="radio"/> US Residency <input type="radio"/> Non US Residency <input type="radio"/> Active US Military Service					
<b>City</b>	Raleigh	<b>State/Province</b>	NC	<b>Country of Residence</b>	US
<b>Mailing Address of Inventor:</b>					
<b>Address 1</b>	824 Historian Street				
<b>Address 2</b>					
<b>City</b>	Raleigh	<b>State/Province</b>	NC		
<b>Postal Code</b>	27603	<b>Country i</b>	US		
<b>Inventor 2</b> <span style="float: right;">Remove</span>					
<b>Legal Name</b>					
<b>Prefix</b>	<b>Given Name</b>	<b>Middle Name</b>	<b>Family Name</b>	<b>Suffix</b>	
	Jesse	Berkley	Tucker		
<b>Residence Information (Select One)</b> <input checked="" type="radio"/> US Residency <input type="radio"/> Non US Residency <input type="radio"/> Active US Military Service					
<b>City</b>	Knightdale	<b>State/Province</b>	NC	<b>Country of Residence</b>	US
<b>Mailing Address of Inventor:</b>					
<b>Address 1</b>	3701 Ramsey Creek Drive				
<b>Address 2</b>					
<b>City</b>	Knightdale	<b>State/Province</b>	NC		
<b>Postal Code</b>	27545	<b>Country i</b>	US		
<b>Inventor 3</b> <span style="float: right;">Remove</span>					
<b>Legal Name</b>					
<b>Prefix</b>	<b>Given Name</b>	<b>Middle Name</b>	<b>Family Name</b>	<b>Suffix</b>	
	Michael	Edward	Aumer		
<b>Residence Information (Select One)</b> <input checked="" type="radio"/> US Residency <input type="radio"/> Non US Residency <input type="radio"/> Active US Military Service					

Under the Paperwork Reduction Act of 1995, no persons are required to respond to a collection of information unless it contains a valid OMB control number.

<b>Application Data Sheet 37 CFR 1.76</b>	Attorney Docket Number	9653-7TSCT2
	Application Number	
Title of Invention	METHODS AND APPARATUS FOR GENERATING DATA STRINGS CONTAINING PHYSIOLOGICAL AND MOTION-RELATED INFORMATION	

City	Raleigh	State/Province	NC	Country of Residence	US
------	---------	----------------	----	----------------------	----

**Mailing Address of Inventor:**

Address 1	2218 The Circle				
Address 2					
City	Raleigh	State/Province	NC		
Postal Code	27608	Country	US		

All Inventors Must Be Listed - Additional Inventor Information blocks may be generated within this form by selecting the **Add** button.

**Correspondence Information:**

Enter either Customer Number or complete the Correspondence Information section below. For further information see 37 CFR 1.33(a).

An Address is being provided for the correspondence information of this application.

Customer Number	20792		
Email Address		<input type="button" value="Add Email"/>	<input type="button" value="Remove Email"/>

**Application Information:**

Title of the Invention	METHODS AND APPARATUS FOR GENERATING DATA STRINGS CONTAINING PHYSIOLOGICAL AND MOTION-RELATED INFORMATION		
Attorney Docket Number	9653-7TSCT2	Small Entity Status Claimed	<input type="checkbox"/>
Application Type	Nonprovisional		
Subject Matter	Utility		
Total Number of Drawing Sheets (if any)		Suggested Figure for Publication (if any)	

**Filing By Reference :**

Only complete this section when filing an application by reference under 35 U.S.C. 111(c) and 37 CFR 1.57(a). Do not complete this section if application papers including a specification and any drawings are being filed. Any domestic benefit or foreign priority information must be provided in the appropriate section(s) below (i.e., "Domestic Benefit/National Stage Information" and "Foreign Priority Information").

For the purposes of a filing date under 37 CFR 1.53(b), the description and any drawings of the present application are replaced by this reference to the previously filed application, subject to conditions and requirements of 37 CFR 1.57(a).

Application number of the previously filed application	Filing date (YYYY-MM-DD)	Intellectual Property Authority or Country

**Publication Information:**

Request Early Publication (Fee required at time of Request 37 CFR 1.219)

**Request Not to Publish.** I hereby request that the attached application not be published under 35 U.S.C. 122(b) and certify that the invention disclosed in the attached application **has not and will not** be the subject of an application filed in another country, or under a multilateral international agreement, that requires publication at eighteen months after filing.

Under the Paperwork Reduction Act of 1995, no persons are required to respond to a collection of information unless it contains a valid OMB control number.

<b>Application Data Sheet 37 CFR 1.76</b>	Attorney Docket Number	9653-7TSCT2
	Application Number	
Title of Invention	METHODS AND APPARATUS FOR GENERATING DATA STRINGS CONTAINING PHYSIOLOGICAL AND MOTION-RELATED INFORMATION	

### Representative Information:

Representative information should be provided for all practitioners having a power of attorney in the application. Providing this information in the Application Data Sheet does not constitute a power of attorney in the application (see 37 CFR 1.32). Either enter Customer Number or complete the Representative Name section below. If both sections are completed the customer Number will be used for the Representative Information during processing.

Please Select One:	<input checked="" type="radio"/> Customer Number	<input type="radio"/> US Patent Practitioner	<input type="radio"/> Limited Recognition (37 CFR 11.9)
Customer Number	20792		

### Domestic Benefit/National Stage Information:

This section allows for the applicant to either claim benefit under 35 U.S.C. 119(e), 120, 121, or 365(c) or indicate National Stage entry from a PCT application. Providing this information in the application data sheet constitutes the specific reference required by 35 U.S.C. 119(e) or 120, and 37 CFR 1.78. When referring to the current application, please leave the application number blank.

Prior Application Status	Pending	<a href="#">Remove</a>	
Application Number	Continuity Type	Prior Application Number	Filing Date (YYYY-MM-DD)
	Continuation of	12691388	2010-01-21
Prior Application Status	Expired	<a href="#">Remove</a>	
Application Number	Continuity Type	Prior Application Number	Filing Date (YYYY-MM-DD)
12691388	Claims benefit of provisional	61208567	2009-02-25
Prior Application Status	Expired	<a href="#">Remove</a>	
Application Number	Continuity Type	Prior Application Number	Filing Date (YYYY-MM-DD)
12691388	Claims benefit of provisional	61208574	2009-02-25
Prior Application Status	Expired	<a href="#">Remove</a>	
Application Number	Continuity Type	Prior Application Number	Filing Date (YYYY-MM-DD)
12691388	Claims benefit of provisional	61212444	2009-04-13
Prior Application Status	Expired	<a href="#">Remove</a>	
Application Number	Continuity Type	Prior Application Number	Filing Date (YYYY-MM-DD)
12691388	Claims benefit of provisional	61274191	2009-08-14

Additional Domestic Benefit/National Stage Data may be generated within this form by selecting the **Add** button.

### Foreign Priority Information:



Under the Paperwork Reduction Act of 1995, no persons are required to respond to a collection of information unless it contains a valid OMB control number.

<b>Application Data Sheet 37 CFR 1.76</b>	Attorney Docket Number	9653-7TSCT2
	Application Number	
Title of Invention	METHODS AND APPARATUS FOR GENERATING DATA STRINGS CONTAINING PHYSIOLOGICAL AND MOTION-RELATED INFORMATION	

This section allows for the applicant to claim priority to a foreign application. Providing this information in the application data sheet constitutes the claim for priority as required by 35 U.S.C. 119(b) and 37 CFR 1.55(d). When priority is claimed to a foreign application that is eligible for retrieval under the priority document exchange program (PDX)<sup>1</sup> the information will be used by the Office to automatically attempt retrieval pursuant to 37 CFR 1.55(h)(1) and (2). Under the PDX program, applicant bears the ultimate responsibility for ensuring that a copy of the foreign application is received by the Office from the participating foreign intellectual property office, or a certified copy of the foreign priority application is filed, within the time period specified in 37 CFR 1.55(g)(1).

Application Number	Country <sup>i</sup>	Filing Date (YYYY-MM-DD)	Access Code <sup>j</sup> (if applicable)

Additional Foreign Priority Data may be generated within this form by selecting the **Add** button.

## Statement under 37 CFR 1.55 or 1.78 for AIA (First Inventor to File) Transition Applications

- This application (1) claims priority to or the benefit of an application filed before March 16, 2013 and (2) also contains, or contained at any time, a claim to a claimed invention that has an effective filing date on or after March 16, 2013.
- NOTE: By providing this statement under 37 CFR 1.55 or 1.78, this application, with a filing date on or after March 16, 2013, will be examined under the first inventor to file provisions of the AIA.

## Authorization to Permit Access:

- Authorization to Permit Access to the Instant Application by the Participating Offices

Under the Paperwork Reduction Act of 1995, no persons are required to respond to a collection of information unless it contains a valid OMB control number.

<b>Application Data Sheet 37 CFR 1.76</b>	Attorney Docket Number	9653-7TSCT2
	Application Number	
Title of Invention	METHODS AND APPARATUS FOR GENERATING DATA STRINGS CONTAINING PHYSIOLOGICAL AND MOTION-RELATED INFORMATION	

If checked, the undersigned hereby grants the USPTO authority to provide the European Patent Office (EPO), the Japan Patent Office (JPO), the Korean Intellectual Property Office (KIPO), the World Intellectual Property Office (WIPO), and any other intellectual property offices in which a foreign application claiming priority to the instant patent application is filed access to the instant patent application. See 37 CFR 1.14(c) and (h). This box should not be checked if the applicant does not wish the EPO, JPO, KIPO, WIPO, or other intellectual property office in which a foreign application claiming priority to the instant patent application is filed to have access to the instant patent application.

In accordance with 37 CFR 1.14(h)(3), access will be provided to a copy of the instant patent application with respect to: 1) the instant patent application-as-filed; 2) any foreign application to which the instant patent application claims priority under 35 U.S.C. 119(a)-(d) if a copy of the foreign application that satisfies the certified copy requirement of 37 CFR 1.55 has been filed in the instant patent application; and 3) any U.S. application-as-filed from which benefit is sought in the instant patent application.

In accordance with 37 CFR 1.14(c), access may be provided to information concerning the date of filing this Authorization.

### Applicant Information:

Providing assignment information in this section does not substitute for compliance with any requirement of part 3 of Title 37 of CFR to have an assignment recorded by the Office.

#### Applicant 1

If the applicant is the inventor (or the remaining joint inventor or inventors under 37 CFR 1.45), this section should not be completed. The information to be provided in this section is the name and address of the legal representative who is the applicant under 37 CFR 1.43; or the name and address of the assignee, person to whom the inventor is under an obligation to assign the invention, or person who otherwise shows sufficient proprietary interest in the matter who is the applicant under 37 CFR 1.46. If the applicant is an applicant under 37 CFR 1.46 (assignee, person to whom the inventor is obligated to assign, or person who otherwise shows sufficient proprietary interest) together with one or more joint inventors, then the joint inventor or inventors who are also the applicant should be identified in this section.

Clear

<input checked="" type="radio"/> Assignee	<input type="radio"/> Legal Representative under 35 U.S.C. 117	<input type="radio"/> Joint Inventor
<input type="radio"/> Person to whom the inventor is obligated to assign.	<input type="radio"/> Person who shows sufficient proprietary interest	

If applicant is the legal representative, indicate the authority to file the patent application, the inventor is:

Name of the Deceased or Legally Incapacitated Inventor :

If the Applicant is an Organization check here.

Organization Name Valencell, Inc.

#### Mailing Address Information For Applicant:

Address 1	2800-154 Sumner Blvd.		
Address 2			
City	Raleigh	State/Province	NC
Country	US	Postal Code	27616
Phone Number		Fax Number	

Under the Paperwork Reduction Act of 1995, no persons are required to respond to a collection of information unless it contains a valid OMB control number.

<b>Application Data Sheet 37 CFR 1.76</b>	Attorney Docket Number	9653-7TSCT2
	Application Number	
Title of Invention	METHODS AND APPARATUS FOR GENERATING DATA STRINGS CONTAINING PHYSIOLOGICAL AND MOTION-RELATED INFORMATION	

Email Address	
---------------	--

Additional Applicant Data may be generated within this form by selecting the Add button.

### Assignee Information including Non-Applicant Assignee Information:

Providing assignment information in this section does not substitute for compliance with any requirement of part 3 of Title 37 of CFR to have an assignment recorded by the Office.

<b>Assignee 1</b>
-------------------

Complete this section if assignee information, including non-applicant assignee information, is desired to be included on the patent application publication. An assignee-applicant identified in the "Applicant Information" section will appear on the patent application publication as an applicant. For an assignee-applicant, complete this section only if identification as an assignee is also desired on the patent application publication.

If the Assignee or Non-Applicant Assignee is an Organization check here.	<input type="checkbox"/>
--	--------------------------

Prefix	Given Name	Middle Name	Family Name	Suffix

### Mailing Address Information For Assignee including Non-Applicant Assignee:

Address 1				
Address 2				
City		State/Province		
Country <sup>i</sup>		Postal Code		
Phone Number		Fax Number		
Email Address				

Additional Assignee or Non-Applicant Assignee Data may be generated within this form by selecting the Add button.

### Signature:

NOTE: This form must be signed in accordance with 37 CFR 1.33. See 37 CFR 1.4 for signature requirements and certifications.

Signature			Date (YYYY-MM-DD)	2014-02-19	
First Name	Needham J.	Last Name	Boddie, II	Registration Number	40519

Additional Signature may be generated within this form by selecting the Add button.

Under the Paperwork Reduction Act of 1995, no persons are required to respond to a collection of information unless it contains a valid OMB control number.

<b>Application Data Sheet 37 CFR 1.76</b>	Attorney Docket Number	9653-7TSCT2
	Application Number	
Title of Invention	METHODS AND APPARATUS FOR GENERATING DATA STRINGS CONTAINING PHYSIOLOGICAL AND MOTION-RELATED INFORMATION	

This collection of information is required by 37 CFR 1.76. The information is required to obtain or retain a benefit by the public which is to file (and by the USPTO to process) an application. Confidentiality is governed by 35 U.S.C. 122 and 37 CFR 1.14. This collection is estimated to take 23 minutes to complete, including gathering, preparing, and submitting the completed application data sheet form to the USPTO. Time will vary depending upon the individual case. Any comments on the amount of time you require to complete this form and/or suggestions for reducing this burden, should be sent to the Chief Information Officer, U.S. Patent and Trademark Office, U.S. Department of Commerce, P.O. Box 1450, Alexandria, VA 22313-1450. DO NOT SEND FEES OR COMPLETED FORMS TO THIS ADDRESS. **SEND TO: Commissioner for Patents, P.O. Box 1450, Alexandria, VA 22313-1450.**

## METHODS AND APPARATUS FOR GENERATING DATA STRINGS CONTAINING PHYSIOLOGICAL AND MOTION-RELATED INFORMATION

### RELATED APPLICATIONS

This application is a continuation application of pending U.S. Patent Application Serial No. 12/691,388, filed January 21, 2010, which claims the benefit of and priority to U.S. Provisional Patent Application No. 61/208,567 filed  
5 02/25/2009, U.S. Provisional Patent Application No. 61/208,574 filed 02/25/2009, U.S. Provisional Patent Application No. 61/212,444 filed 4/13/2009, and U.S. Provisional Patent Application No. 61/274,191 filed 8/14/2009, the disclosures of which are incorporated herein by reference as if set forth in their entireties.

### 10 FIELD OF THE INVENTION

The present invention relates generally to headsets and, more particularly, to headset earbuds.

### BACKGROUND OF THE INVENTION

15 There is growing market demand for personal health and environmental monitors, for example, for gauging overall health and metabolism during exercise, athletic training, dieting, daily life activities, sickness, and physical therapy. However, traditional health monitors and environmental monitors may be bulky, rigid, and uncomfortable – generally not suitable for use  
20 during daily physical activity. There is also growing interest in generating and comparing health and environmental exposure statistics of the general public and particular demographic groups. For example, collective statistics may enable the healthcare industry and medical community to direct healthcare resources to where they are most highly valued. However, methods of collecting these  
25 statistics may be expensive and laborious, often utilizing human-based recording/analysis steps at multiple sites.

As such, improved ways of collecting, storing and analyzing physiological information are needed. In addition, improved ways of seamlessly extracting physiological information from a person during everyday life activities, especially during high activity levels, may be important for enhancing fitness training and healthcare quality, promoting and facilitating prevention, and reducing healthcare costs.

## SUMMARY

It should be appreciated that this Summary is provided to introduce a selection of concepts in a simplified form, the concepts being further described below in the Detailed Description. This Summary is not intended to identify key features or essential features of this disclosure, nor is it intended to limit the scope of the invention.

According to some embodiments of the present invention, a headset configured to be attached to the ear of a person includes a base, an earbud housing extending outwardly from the base that is configured to be positioned within an ear of a subject, and a cover surrounding the earbud housing. The base includes a speaker, an optical emitter, and an optical detector. The cover includes light transmissive material that is in optical communication with the optical emitter and the optical detector and serves as a light guide to deliver light from the optical emitter into the ear canal of the subject wearing the headset at one or more predetermined locations and to collect light external to the earbud housing and deliver the collected light to the optical detector. The optical emitter, via the light-guiding cover, directs optical energy towards a particular region of ear and the optical detector detects secondary optical energy emanating from the ear region. In some embodiments, the optical detector may include an optical filter configured to pass secondary optical energy at selective wavelengths. In some embodiments, the light transmissive material of the cover may be configured, for example via the use of cladding and/or light reflective material, such that the cover serves as a light guide that is coupled in parallel to the optical emitter and detector. In some embodiments, the light transmissive material of the cover may be configured, for example via the use of cladding and/or light reflective material, such that the cover serves as a light guide that is coupled perpendicular to the optical emitter and detector.

In some embodiments, the headset may include various electronic components secured to the base. For example, the headset may include one or more environmental sensors configured to detect and/or measure environmental conditions in a vicinity of the headset. The headset may include a signal  
5 processor configured to receive and process signals produced by the optical detector. For example, in some embodiments, a signal processor may be configured to extract secondary optical energy and remove optical noise or environmental noise. The headset may include a signal processor configured to receive and process signals produced by the one or more environmental  
10 sensors. In addition, the headset may include a transmitter configured to transmit signals processed by the signal processor to a remote device in real time. Headsets according to embodiments of the present invention may utilize, for example, Bluetooth®, Wi-Fi, ZigBee, or other wireless transmitters.

In some embodiments, a housing is secured to and overlies the  
15 base so as to enclose and protect the speaker, optical emitter and optical detector, as well as other electronic components secured to the base (e.g., sensors, processor, transmitter etc.).

The earbud housing is in acoustical communication with the speaker and has at least one aperture through which sound from the speaker  
20 can pass. The light-guiding cover surrounding the earbud housing also includes at least one aperture through which sound from the speaker can pass. The cover may be formed from a soft, resilient material, such as silicone which deforms when inserted within an ear canal of a subject. In some embodiments, the cover includes an alignment member that facilitates alignment of the earbud housing  
25 within an ear canal of a subject.

Light directed into the ear of a subject from a light emitter and the subsequent collection of light at a light detector, according to embodiments of the present invention, may be utilized for detecting and/or measuring, among other things, body temperature, skin temperature, blood gas levels, muscle  
30 tension, heart rate, blood flow, cardiopulmonary functions, etc.

In some embodiments of the present invention, the light-guiding cover may include a lens that is in optical communication with the optical emitter and/or optical detector. The lens may be configured to focus light emitted by the optical emitter and/or to focus collected light toward the optical detector. In some

embodiments, multiple lenses may be incorporated into a light-guiding cover.

In some embodiments, the light-guiding cover may include a light diffusion region in optical communication with the light transmissive material that diffuses light emitted by the optical detector.

5 In some embodiments, the light-guiding cover may include a luminescence-generating region, such as a phosphor-containing region, that is in optical communication with the light transmissive material. The luminescence-generating region may be embedded within the light-guiding cover and/or on a surface of the light-guiding cover. The luminescence-generating region is  
10 configured to receive light emitted by the optical emitter and convert at least a portion of the received light to light having a different wavelength from that of the received light.

In some embodiments, the light-guiding cover includes one or more grooves formed therein. Each groove is configured to direct external light to the  
15 optical detector.

In some embodiments, the light transmissive material of the light-guiding cover is configured to direct light from the optical emitter to a plurality of locations at an outer surface of the cover for delivery into an ear canal of a subject.

20 In some embodiments, the light transmissive material of the light-guiding cover is a translucent material or includes translucent material in selected locations.

In some embodiments, a light reflective material is on at least a portion of one or both of the inner and outer surfaces of the light-guiding cover.

25 According to some embodiments of the present invention, a light-guiding earbud for a headset includes light transmissive material that is in optical communication with an optical emitter and optical detector associated with the headset. The light transmissive material is configured to deliver light from the optical emitter into the ear canal of a subject at one or more predetermined  
30 locations and to collect light external to the earbud housing and deliver the collected light to the optical detector. In some embodiments, the light emitter and light detector may be integral with the earbud. For example, in some embodiments, a flexible optical emitter is incorporated within the earbud and is in optical communication with the light transmissive material.



In some embodiments, an earbud includes at least one lens in optical communication with the light transmissive material. Each lens may be configured to focus light from the optical emitter onto one or more predetermined locations in the ear of a subject and/or to focus collected external light onto the optical detector

In some embodiments of the present invention, an earbud may include luminescent material. Luminescent light is generated from optical excitation of the luminescent material by an optical emitter.

In some embodiments of the present invention, an earbud may integrate a sensor module containing a plurality of sensor elements for measuring physiological information and at least one noise source for measuring noise information. A "noise source", as used herein, refers to a sensor, such as an optical sensor, inertial sensor, electrically conductive sensor, capacitive sensor, inductive sensor, etc., and derives its name from the fact that it is a source of input to a filter, such as an adaptive filter described below.

The physiological sensors of the sensor module may generate a signal that includes physiological information plus noise information. The noise may be removed by combining the physiological information and noise information from the sensor module with noise information from the noise source of the sensor module via an electronic filtering method, such as a signal processing technique. Specific examples of such signal processing techniques include FIR (Finite Impulse Response), IIR (Infinite Impulse Response), informatics, machine learning, and adaptive filter methods. The output of the adaptive filter may be a physiological signal that is wholly or partially free of noise. In some embodiments, motion-related noise from a subject activity such as running may be removed from the physiological plus noise signal generated by a photoplethysmography (PPG) sensor for measuring blood constituent levels or blood flow properties, such as blood oxygen level,  $VO_2$ , or heart rate.

In some embodiments of the present invention, the noise source input of an adaptive filter may include a "blocked channel" of optical energy, an inertial sensor, or environmental energy. In some embodiments, the environmental energy may be unwanted ambient optical noise.

In some embodiments of the present invention, a processor/multiplexor processes physiological signals and noise signals into a

data string. This data string may contain information relating to physiological information and motion-related information. The processing method may include signal processing techniques such as pre-adaptive signal conditioning, adaptive filtering, and parameter extraction.

5                   In some embodiments, an earbud includes one or more sensor modules that includes one or more sensors for sensing physiological information and environmental information, such as noise, for example. As such, the earbud may function as a physiological monitor as well as an environmental monitor. In some embodiments, the earbud may include a microprocessor that is in  
10                   electrical communication with the sensor module(s). For example, a microprocessor incorporated into an earbud may be configured to execute an adaptive filter algorithm to remove noise from at least one signal generated by a sensor module in the earbud. A microprocessor may also be configured to process information from the one or more sensors to generate a digital output  
15                   string, wherein the digital output string includes a plurality of physiological and motion-related information.

                    Physiological sensors that may be incorporated into headsets and/or earbuds, according to some embodiments of the present invention, may be configured to detect and/or measure one or more of the following types of  
20                   physiological information: heart rate, pulse rate, breathing rate, blood flow,  $VO_2$ ,  $VO_2$ max, heartbeat signatures, cardio-pulmonary health, organ health, metabolism, electrolyte type and/or concentration, physical activity, caloric intake, caloric metabolism, blood metabolite levels or ratios, blood pH level, physical and/or psychological stress levels and/or stress level indicators, drug  
25                   dosage and/or dosimetry, physiological drug reactions, drug chemistry, biochemistry, position and/or balance, body strain, neurological functioning, brain activity, brain waves, blood pressure, cranial pressure, hydration level, auscultatory information, auscultatory signals associated with pregnancy, physiological response to infection, skin and/or core body temperature, eye  
30                   muscle movement, blood volume, inhaled and/or exhaled breath volume, physical exertion, exhaled breath physical and/or chemical composition, the presence and/or identity and/or concentration of viruses and/or bacteria, foreign matter in the body, internal toxins, heavy metals in the body, anxiety, fertility, ovulation, sex hormones, psychological mood, sleep patterns, hunger and/or

thirst, hormone type and/or concentration, cholesterol, lipids, blood panel, bone density, organ and/or body weight, reflex response, sexual arousal, mental and/or physical alertness, sleepiness, auscultatory information, response to external stimuli, swallowing volume, swallowing rate, sickness, voice characteristics, voice tone, voice pitch, voice volume, vital signs, head tilt, allergic reactions, inflammation response, auto-immune response, mutagenic response, DNA, proteins, protein levels in the blood, water content of the blood, pheromones, internal body sounds, digestive system functioning, cellular regeneration response, healing response, stem cell regeneration response, etc.

5  
10  
15  
20  
25  
30

Environmental sensors that may be incorporated into headsets and/or earbuds, according to some embodiments of the present invention, may be configured to detect and/or measure one or more of the following types of environmental information: climate, humidity, temperature, pressure, barometric pressure, soot density, airborne particle density, airborne particle size, airborne particle shape, airborne particle identity, volatile organic chemicals (VOCs), hydrocarbons, polycyclic aromatic hydrocarbons (PAHs), carcinogens, toxins, electromagnetic energy, optical radiation, X-rays, gamma rays, microwave radiation, terahertz radiation, ultraviolet radiation, infrared radiation, radio waves, atomic energy alpha particles, atomic energy beta-particles, gravity, light intensity, light frequency, light flicker, light phase, ozone, carbon monoxide, carbon dioxide, nitrous oxide, sulfides, airborne pollution, foreign material in the air, viruses, bacteria, signatures from chemical weapons, wind, air turbulence, sound and/or acoustical energy, ultrasonic energy, noise pollution, human voices, animal sounds, diseases expelled from others, exhaled breath and/or breath constituents of others, toxins from others, pheromones from others, industrial and/or transportation sounds, allergens, animal hair, pollen, exhaust from engines, vapors and/or fumes, fuel, signatures for mineral deposits and/or oil deposits, snow, rain, thermal energy, hot surfaces, hot gases, solar energy, hail, ice, vibrations, traffic, the number of people in a vicinity of the person, coughing and/or sneezing sounds from people in the vicinity of the person, loudness and/or pitch from those speaking in the vicinity of the person.

According to some embodiments of the present invention, earbuds for headsets may include a chipset having at least one sensor element, noise source element, signal processor, input/output line, digital control, and power

regulator.

Light-guiding earbuds according to the various embodiments of the present invention may be utilized with mono headsets (i.e., headsets having one earbud) as well as stereo headsets (i.e., headsets having two earbuds).

5 Additionally, the light-guiding region of earbuds, according to embodiments of the present invention, may be integrated not only into an earbud cover and earbud housing, but also into each or all components of an earbud. Moreover, light-guiding earbuds according to the various embodiments of the present invention may be utilized with hearing aids, body jewelry, or any other  
10 attachment that can be placed near the head region, such as eye glasses or shades, a headband, a cap, helmet, visor, or the like.

According to some embodiments of the present invention, a monitoring device includes a circular band capable of encircling a finger of a subject, and a base having an optical emitter and an optical detector attached to  
15 the circular band. The circular band includes light transmissive material in optical communication with the optical emitter and optical detector that is configured to deliver light from the optical emitter to one or more portions of the finger of the subject and to collect light from one or more portions of the finger of the subject and deliver the collected light to the optical detector. In some embodiments, the  
20 circular band includes first and second concentric body portions.

In some embodiments, the circular band includes a lens region in optical communication with the optical emitter that focuses light emitted by the optical emitter and/or that collects light reflected from a finger. In some  
25 embodiments the circular band includes a phosphor-containing region in optical communication with the light transmissive material, wherein the phosphor-containing region receives light emitted by the optical emitter and converts at least a portion of the received light to light having a different wavelength from the received light.

In some embodiments, the light transmissive material of the  
30 circular band has an outer surface and an inner surface, and a cladding material, such as light reflective material, is on (or near) at least a portion of one or both of the inner and outer surfaces.

In some embodiments, the base includes one or more of the following: a signal processor configured to receive and process signals produced

by the optical detector, a transmitter configured to transmit signals processed by the signal processor to a remote device.

According to some embodiments of the present invention, a monitoring device configured to be attached to the body of a subject includes a base having an optical emitter and an optical detector, and light transmissive material attached to the base. The light transmissive material is in optical communication with the optical emitter and optical detector and is configured to deliver light from the optical emitter to one or more portions of the body of the subject and to collect light from one or more portions of the body of the subject and deliver the collected light to the optical detector. The light transmissive material may include adhesive material in one or more locations that is configured to adhesively secure the device to the body of the subject.

In some embodiments, an outer body portion is attached to the base and to the light transmissive material. The outer body portion may include adhesive material in one or more locations that is configured to adhesively secure the device to the body of the subject.

In some embodiments, the light transmissive material includes a lens region that is in optical communication with the optical emitter and that focuses light emitted by the optical emitter and/or that collects light reflected from a finger. In some embodiments, the light transmissive material includes a phosphor-containing region that receives light emitted by the optical emitter and converts at least a portion of the received light to light having a different wavelength from the received light. In some embodiments, the light transmissive material has an outer surface and an inner surface, and a light reflective material is disposed on or near at least a portion of one or both of the inner and outer surfaces.

In some embodiments, the base includes one or more of the following: a signal processor configured to receive and process signals produced by the optical detector, a transmitter configured to transmit signals processed by the signal processor to a remote device.

It is noted that aspects of the invention described with respect to one embodiment may be incorporated in a different embodiment although not specifically described relative thereto. That is, all embodiments and/or features of any embodiment can be combined in any way and/or combination. Applicant

reserves the right to change any originally filed claim or file any new claim accordingly, including the right to be able to amend any originally filed claim to depend from and/or incorporate any feature of any other claim although not originally claimed in that manner. These and other objects and/or aspects of the present invention are explained in detail below.

### BRIEF DESCRIPTION OF THE DRAWINGS

The accompanying drawings, which form a part of the specification, illustrate various embodiments of the present invention. The drawings and description together serve to fully explain embodiments of the present invention.

Fig. 1 is an exploded perspective view of a headset with a light-guiding earbud, according to some embodiments of the present invention.

Fig. 2 is a perspective view of a stereo headset incorporating light-guiding earbuds, according to some embodiments of the present invention.

Fig. 3 is a side section view of a light-guiding earbud for a headset, according to some embodiments of the present invention.

Figs. 4A-4D are side section views of light-guiding earbuds for a headset, according to some embodiments of the present invention.

Fig. 5 is a side section view of a light-guiding earbud for a headset, according to some embodiments of the present invention.

Fig. 6 is a side section view of a light-guiding earbud for a headset, according to some embodiments of the present invention..

Fig. 7A is a side section view of a light-guiding earbud for a headset, according to some embodiments of the present invention.

Fig. 7B is a perspective view of a flexible optical emitter utilized in the earbud of Fig. 7A, according to some embodiments of the present invention.

Fig. 8A is a side section view of a light-guiding earbud for a headset, according to some embodiments of the present invention.

Fig. 8B is a cross-sectional view of the earbud of Fig. 8A taken along lines 8B-8B.

Fig. 8C is a side section view of a light-guiding earbud for a headset, according to some embodiments of the present invention.

Fig. 8D is a side section view of a light-guiding earbud for a headset, according to some embodiments of the present invention.

Fig. 9A is a side section view of a light-guiding earbud for a headset, according to some embodiments of the present invention.

Fig. 9B is a cross-sectional view of the earbud of Fig. 9A taken along lines 9B-9B.

5 Fig. 9C illustrates luminescent particles within the earbud cover of Figs. 9A-9B, according to some embodiments of the present invention.

Fig. 9D is a side section view of a light-guiding earbud for a headset, according to some embodiments of the present invention.

10 Fig. 9E is a cross-sectional view of the earbud of Fig. 9D taken along lines 9E-9E.

Fig. 10 illustrates various anatomy of a human ear.

Fig. 11A is a side section view of a light-guiding earbud for a headset, according to some embodiments of the present invention.

15 Fig. 11B is a cross-sectional view of the earbud of Fig. 11A taken along lines 11B-11B.

Figs. 12A-12B illustrate respective opposite sides of a sensor module that may be located near the periphery of an earbud, according to some embodiments of the present invention.

20 Fig. 13 illustrates an adaptive filter and noise source for removing noise from a noisy physiological signal, according to some embodiments of the present invention.

Figs. 14A-14D are respective graphs of time-dependent data collected from a light-guiding earbud worn by a person, according to some embodiments of the present invention.

25 Fig. 15 is a graph of processed physiological signal data from a headset having one or more light-guiding earbuds, according to some embodiments of the present invention.

30 Fig. 16 is a flow chart of operations for extracting physiological information from headset sensor signals, according to some embodiments of the present invention.

Fig. 17 is a block diagram that illustrates sensor signals being processed into a digital data string including activity data and physiological data, according to some embodiments of the present invention.

Fig. 18 illustrates a digital data string, according to some

embodiments of the present invention.

Fig. 19 illustrates the optical interaction between the sensor module of Figs. 12A-12B and the skin of a subject.

5 Fig. 20 illustrates a chipset for use in a headset, according to some embodiments of the present invention.

Fig. 21 illustrates a chipset for use in a stereo headset, according to some embodiments of the present invention.

10 Fig. 22A is a top plan view of a monitoring device configured to be attached to finger of a subject, according to some embodiments of the present invention.

Fig. 22B is a cross-sectional view of the monitoring device of Fig. 22A taken along lines 22B-22B.

15 Fig. 23 is a side view of a monitoring device configured to be attached to the body of a subject, according to some embodiments of the present invention.

#### DETAILED DESCRIPTION

20 The present invention will now be described more fully hereinafter with reference to the accompanying figures, in which embodiments of the invention are shown. This invention may, however, be embodied in many different forms and should not be construed as limited to the embodiments set forth herein. Like numbers refer to like elements throughout. In the figures, certain layers, components or features may be exaggerated for clarity, and broken lines illustrate optional features or operations unless specified otherwise.

25 In addition, the sequence of operations (or steps) is not limited to the order presented in the figures and/or claims unless specifically indicated otherwise. Features described with respect to one figure or embodiment can be associated with another embodiment or figure although not specifically described or shown as such.

30 It will be understood that when a feature or element is referred to as being "on" another feature or element, it can be directly on the other feature or element or intervening features and/or elements may also be present. In contrast, when a feature or element is referred to as being "directly on" another feature or element, there are no intervening features or elements present. It will



also be understood that, when a feature or element is referred to as being "connected", "attached" or "coupled" to another feature or element, it can be directly connected, attached or coupled to the other feature or element or intervening features or elements may be present. In contrast, when a feature or element is referred to as being "directly connected", "directly attached" or "directly coupled" to another feature or element, there are no intervening features or elements present. Although described or shown with respect to one embodiment, the features and elements so described or shown can apply to other embodiments. It will also be appreciated by those of skill in the art that references to a structure or feature that is disposed "adjacent" another feature may have portions that overlap or underlie the adjacent feature.

The terminology used herein is for the purpose of describing particular embodiments only and is not intended to be limiting of the invention. As used herein, the singular forms "a", "an" and "the" are intended to include the plural forms as well, unless the context clearly indicates otherwise. It will be further understood that the terms "comprises" and/or "comprising," when used in this specification, specify the presence of stated features, steps, operations, elements, and/or components, but do not preclude the presence or addition of one or more other features, steps, operations, elements, components, and/or groups thereof. As used herein, the term "and/or" includes any and all combinations of one or more of the associated listed items.

Spatially relative terms, such as "under", "below", "lower", "over", "upper" and the like, may be used herein for ease of description to describe one element or feature's relationship to another element(s) or feature(s) as illustrated in the figures. It will be understood that the spatially relative terms are intended to encompass different orientations of the device in use or operation in addition to the orientation depicted in the figures. For example, if a device in the figures is inverted, elements described as "under" or "beneath" other elements or features would then be oriented "over" the other elements or features. Thus, the exemplary term "under" can encompass both an orientation of over and under. The device may be otherwise oriented (rotated 90 degrees or at other orientations) and the spatially relative descriptors used herein interpreted accordingly. Similarly, the terms "upwardly", "downwardly", "vertical", "horizontal" and the like are used herein for the purpose of explanation only unless

specifically indicated otherwise.

It will be understood that although the terms first and second are used herein to describe various features/elements, these features/elements should not be limited by these terms. These terms are only used to distinguish one feature/element from another feature/element. Thus, a first feature/element discussed below could be termed a second feature/element, and similarly, a second feature/element discussed below could be termed a first feature/element without departing from the teachings of the present invention. Like numbers refer to like elements throughout.

Unless otherwise defined, all terms (including technical and scientific terms) used herein have the same meaning as commonly understood by one of ordinary skill in the art to which this invention belongs. It will be further understood that terms, such as those defined in commonly used dictionaries, should be interpreted as having a meaning that is consistent with their meaning in the context of the specification and relevant art and should not be interpreted in an idealized or overly formal sense unless expressly so defined herein. Well-known functions or constructions may not be described in detail for brevity and/or clarity.

The term "headset" includes any type of device or earpiece that may be attached to or near the ear (or ears) of a user and may have various configurations, without limitation. Headsets incorporating light-guiding earbuds as described herein may include mono headsets (one earbud) and stereo headsets (two earbuds), earbuds, hearing aids, ear jewelry, face masks, headbands, and the like.

The term "real-time" is used to describe a process of sensing, processing, or transmitting information in a time frame which is equal to or shorter than the minimum timescale at which the information is needed. For example, the real-time monitoring of pulse rate may result in a single average pulse-rate measurement every minute, averaged over 30 seconds, because an instantaneous pulse rate is often useless to the end user. Typically, averaged physiological and environmental information is more relevant than instantaneous changes. Thus, in the context of the present invention, signals may sometimes be processed over several seconds, or even minutes, in order to generate a "real-time" response.

The term "monitoring" refers to the act of measuring, quantifying, qualifying, estimating, sensing, calculating, interpolating, extrapolating, inferring, deducing, or any combination of these actions. More generally, "monitoring" refers to a way of getting information via one or more sensing elements. For  
5 example, "blood health monitoring" includes monitoring blood gas levels, blood hydration, and metabolite/electrolyte levels.

The term "physiological" refers to matter or energy of or from the body of a creature (*e.g.*, humans, animals, etc.). In embodiments of the present invention, the term "physiological" is intended to be used broadly, covering both  
10 physical and psychological matter and energy of or from the body of a creature. However, in some cases, the term "psychological" is called-out separately to emphasize aspects of physiology that are more closely tied to conscious or subconscious brain activity rather than the activity of other organs, tissues, or cells.

The term "body" refers to the body of a subject (human or animal)  
15 that may wear a headset incorporating one or more light-guiding earbuds, according to embodiments of the present invention.

In the following figures, various headsets and light-guiding earbuds for use with headsets will be illustrated and described for attachment to the ear  
20 of the human body. However, it is to be understood that embodiments of the present invention are not limited to those worn by humans.

The ear is an ideal location for wearable health and environmental monitors. The ear is a relatively immobile platform that does not obstruct a person's movement or vision. Headsets located at an ear have, for example,  
25 access to the inner-ear canal and tympanic membrane (for measuring core body temperature), muscle tissue (for monitoring muscle tension), the pinna and earlobe (for monitoring blood gas levels), the region behind the ear (for measuring skin temperature and galvanic skin response), and the internal carotid artery (for measuring cardiopulmonary functioning), etc. The ear is also at or  
30 near the point of exposure to: environmental breathable toxicants of interest (volatile organic compounds, pollution, etc.; noise pollution experienced by the ear; and lighting conditions for the eye. Furthermore, as the ear canal is naturally designed for transmitting acoustical energy, the ear provides a good location for monitoring internal sounds, such as heartbeat, breathing rate, and mouth motion.

Wireless, Bluetooth®-enabled, and/or other personal communication headsets may be configured to incorporate physiological and/or environmental sensors, according to some embodiments of the present invention. As a specific example, Bluetooth® headsets are typically lightweight, unobtrusive devices that have become widely accepted socially. Moreover, Bluetooth® headsets are cost effective, easy to use, and are often worn by users for most of their waking hours while attending or waiting for cell phone calls. Bluetooth® headsets configured according to embodiments of the present invention are advantageous because they provide a function for the user beyond health monitoring, such as personal communication and multimedia applications, thereby encouraging user compliance. Exemplary physiological and environmental sensors that may be incorporated into a Bluetooth® or other type of headsets include, but are not limited to accelerometers, auscultatory sensors, pressure sensors, humidity sensors, color sensors, light intensity sensors, pressure sensors, etc.

Headsets, both mono (single earbud) and stereo (dual earbuds), incorporating low-profile sensors and other electronics, according to embodiments of the present invention, offer a platform for performing near-real-time personal health and environmental monitoring in wearable, socially acceptable devices. The capability to unobtrusively monitor an individual's physiology and/or environment, combined with improved user compliance, is expected to have significant impact on future planned health and environmental exposure studies. This is especially true for those that seek to link environmental stressors with personal stress level indicators. The large scale commercial availability of this low-cost device can enable cost-effective large scale studies. The combination of monitored data with user location via GPS data can make on-going geographic studies possible, including the tracking of infection over large geographic areas. The commercial application of the proposed platform encourages individual-driven health maintenance and promotes a healthier lifestyle through proper caloric intake and exercise.

Accordingly, some embodiments of the present invention combine a personal communications headset device with one or more physiological and/or environmental sensors. Other embodiments may combine physiological and/or environmental sensors into a headset device.

Optical coupling into the blood vessels of the ear may vary between individuals. As used herein, the term "coupling" refers to the interaction or communication between excitation light entering a region and the region itself. For example, one form of optical coupling may be the interaction between excitation light generated from within a light-guiding earbud and the blood vessels of the ear. In one embodiment, this interaction may involve excitation light entering the ear region and scattering from a blood vessel in the ear such that the intensity of scattered light is proportional to blood flow within the blood vessel. Another form of optical coupling may be the interaction between excitation light generated by an optical emitter within an earbud and the light-guiding region of the earbud. Thus, an earbud with integrated light-guiding capabilities, wherein light can be guided to multiple and/or select regions along the earbud, can assure that each individual wearing the earbud will generate an optical signal related to blood flow through the blood vessels. Optical coupling of light to a particular ear region of one person may not yield photoplethysmographic signals for each person. Therefore, coupling light to multiple regions may assure that at least one blood-vessel-rich region will be interrogated for each person wearing the light-guiding earbud. Coupling multiple regions of the ear to light may also be accomplished by diffusing light from a light source within the earbud.

Embodiments of the present invention are not limited to headsets that communicate wirelessly. In some embodiments of the present invention, headsets configured to monitor an individual's physiology and/or environment may be wired to a device that stores and/or processes data. In some embodiments, this information may be stored on the headset itself. Furthermore, embodiments of the present invention are not limited to earbuds. In some embodiments, the light-guiding structure may be molded around another part of the body, such as a digit, finger, toe, limb, around the nose or earlobe, or the like. In other embodiments, the light-guiding structure may be integrated into a patch, such as a bandage that sticks on a person's body.

Referring to Fig. 1, a headset 10 according to some embodiments of the present invention is illustrated. The illustrated headset 10 includes a base 12, a headset housing 14, an earbud housing 16, and a cover 18 that surrounds the earbud housing 16. The base 12 includes a main circuit board 20 that

supports and/or is connected to various electronic components. In the illustrated embodiment, a speaker 22, optical emitter 24, optical detectors 26, and thermopile 28 (described below) are mounted onto a secondary circuit board 32 which is secured to the main circuit board 20. The earbud housing surrounds the speaker 22, optical emitter 24, optical detectors 26, and thermopile 28.

Collectively, the earbud housing 16, cover 18, and various electronic components (e.g., speaker 22, optical emitter 24, optical detectors 26, thermopile 28) located within the earbud housing 16 of the illustrated headset 10 may be referred to as an earbud 30. The headset housing 14 is secured to the base 12 and is configured to enclose and protect the various electronic components mounted to the base (e.g., main circuit board 20 and components secured thereto, etc.) from ambient interference (air, humidity, particulates, electromagnetic interference, etc).

Each optical detector 26 may be a photodiode, photodetector, phototransistor, thyristor, solid state device, optical chipset, or the like. The optical emitter 24 may be a light-emitting diode (LED), laser diode (LD), compact incandescent bulb, micro-plasma emitter, IR blackbody source, or the like. The speaker 22 may be a compact speaker, such as an inductive speaker, piezoelectric speaker, electrostatic speaker, or the like. One or more microphones, such as electrets, MEMS, acoustic transducers, or the like, may also be located within the headset housing or earbud housing to pick up speech, physiological sounds, and/or environmental sounds.

The main circuit board 20 and secondary circuit board 32 may also support one or more sensor modules (not shown) that contain various physiological and/or environmental sensors. For example, a sensor module, such as sensor module 70 illustrated in Figs. 12A-12B, may be attached to the circuit boards 20, 32. The circuit boards 20, 32 also may include at least one signal processor (not shown), at least one wireless module (not shown) for communicating with a remote device, and/or at least one memory storage device (not shown). An exemplary wireless module may include a wireless chip, antenna, or RFID tag. In some embodiments, the wireless module may include a low-range wireless chip or chipset, such as a Bluetooth® or ZigBee chip. These electronic components may be located on the main circuit board 20, or on another circuit board, such as the secondary circuit board 32, attached to the

main circuit board.

Secondary circuit board 32 may also include a temperature sensor, such as a thermopile 28 mounted thereto. The thermopile 28 is oriented so as to point towards the tympanic membrane within the ear of a subject wearing the headset 10 through the acoustic orifices 34a, 34b in the earbud housing 16 and cover 18, respectively. The secondary circuit board 32 may be in electrical contact with the main circuit board 20 via soldering, connectors, wiring, or the like. A battery 36, such as a lithium polymer battery or other portable battery, may be mounted to the main circuit board 20 and may be charged via a USB charge port 38. Although not shown in Fig. 1, an ear hook may be attached to the base 12 or housing 14 to help stabilize the earbud 30 and headset 10 worn by a subject and such that the earbud 30 is consistently placed at the same location within the ear canal of a subject.

In the illustrated embodiment, the earbud housing 16 is in acoustical communication with the speaker 22 and includes an aperture 34a through which sound from the speaker 22 can pass. However, additional apertures may also be utilized. The cover 18 also includes at least one aperture 34b through which sound from the speaker 22 can pass. The thermopile 28 is used as a heat sensor and measures thermal radiation from the ear of a subject via the acoustic apertures 34a, 34b. Additional or other sensors may be in the location of the thermopile 28, aligned towards the tympanic membrane, to sense other forms of energy, such as acoustic, mechanical, chemical, optical, or nuclear energy from the tympanic membrane region. For example, a photodetector may replace the thermopile 28 to measure light scattering off the tympanic membrane.

The cover 18 includes light transmissive material in a portion 19 thereof that is referred to as a light-guiding region. The light transmissive material in light-guiding region 19 is in optical communication with the optical emitter 24 and detectors 26. The light transmissive material in light-guiding region 19 is configured to deliver light from the optical emitter 24 into an ear canal of the subject at one or more predetermined locations and to collect light external to the earbud 30 and deliver the collected light to the optical detectors 26. As such, the earbud 30 of the illustrated headset 10 is referred to as a "light-guiding" earbud 30.

In some embodiments, the light transmissive material in the light-guiding region 19 may include a lens (e.g., lens 18L illustrated in Fig. 6). The lens 18L is in optical communication with the optical emitter 24 and/or with the optical detectors 26. For example, a lens 18L may be configured to focus light emitted by the optical emitter 24 onto one or more portions of an ear and/or to focus collected light on the light detectors 26. Lenses are described below with respect to Figs. 5-6.

In some embodiments, the earbud cover 18 may integrate a transparent light-guiding layer, wherein air is utilized as a cladding layer. For example, the earbud cover 18 may include an optically transparent silicone molded layer, and the earbud housing 16 may be removed such that a cladding layer is air. In some embodiments, the earbud housing 16 may be closed, and the light-guiding region 19 may be integrated within the cover 18 or between the housing 16 and cover 18.

The illustrated cover 18 of Fig. 1 includes an alignment member 40 (also referred to as a stabilization arm) that facilitates alignment of the earbud 30 within an ear canal of a subject. The alignment member 40 may facilitate stable measurements of optical scattered light from the ear region, which can be important for PPG measurements and tympanic temperature measurements.

In some embodiments, a light-guiding cover 18 is formed from a soft, resilient material, such as silicone, which deforms when inserted within an ear canal of a subject. However, various materials may be utilized for light-guiding covers 18 and for serving as light guides depending on the type of earbud desired for a particular use case, according to embodiments of the present invention. For example, in some embodiments, a light-guiding cover 18 may be formed from a substantially rigid material such that the light-guiding earbud 30 is substantially rigid. For example, for a running use case, the runner may wish to have firm but soft earbuds, such that the earbud may deform to some extent when inserted into the ear. In such case, the light-guiding region may be silicone or other soft material and the outer cladding may be air, a polymer, plastic, or a soft material having a lower index of refraction than silicone.

Fig. 2 illustrates a stereo headset 100 that utilizes two light-guiding earbuds 130, according to some embodiments of the present invention. The



headset 100 also includes various sensor elements 132 located at several regions in the stereo headset 100. A benefit of the stereo headset 100 may be that the total number of sensors measuring the ear region may be doubled; alternatively, the sensors in each earbud may be halved. Another benefit of the stereo headset is that it may enable stereo music during daily activities. Another benefit of the stereo headset is that asymmetric physiological differences can be detected in the user by measuring each side of the user in real-time. For example, differences in blood flow between right and left sides of a user may be detected, indicating changes in right/left brain activity, the onset of a stroke, localized inflammation, or the like.

Light-guiding earbuds according to various embodiments of the present invention will now be described with respect to Figs. 3, 4A-4D, 5, 6, 7A-7B, 8A-8D, 9A-9B, and 11A-11B. Referring initially to Figs. 3-4, a light-guiding earbud 30 includes a base 50, an earbud housing 16 extending outwardly from the base 50 that is configured to be positioned within an ear E of a subject, and a cover 18 that surrounds the earbud housing 16. The earbud housing 16 is in acoustical communication with a speaker 22 and includes at least one aperture 34a through which sound from the speaker 22 can pass. The cover 18 includes at least one aperture 34b through which sound from the speaker 22 can pass, and includes light transmissive material in optical communication with an optical emitter 24 and detector 26.

The cover 18 includes cladding material 21 on an inner surface 18b thereof and on an outer surface 18a thereof, as illustrated. An end portion 18f of the cover outer surface 18a does not have cladding material. As such, the cover 18 serves as a light guide that delivers light from the optical emitter 24 through the end portion 18f and into the ear canal C of a subject at one or more predetermined locations and that collects light external to the earbud housing 16 and delivers the collected light to the optical detector 26. In the various embodiments described herein, the terms light guide and cover are intended to be interchangeable. However, it should be noted that, in other embodiments, the earbud housing 16 may also serve as a light guide without the need for cover 18.

The base 50 in all of the earbud embodiments (Figs. 3, 4A-4D, 5, 6, 7A-7B, 8A-8D, 9A-9B, and 11A-11B) described herein may include any combination of a printed circuit board, electrical connectors, and housing

component for a headset. For example, the base 50 in Figs. 3-6, 7A-7B, 8A-8D, 9A-9B, and 11A-11B, may include, for example, the base 12 of the headset 10 of Fig. 1, the main circuit board 20 of the headset 10 of Fig. 1, the housing 14 of the headset 10 of Fig. 1, or may be a combination of the base 12, main circuit board  
5 20, and/or housing 14 of the headset 10 of Fig. 1.

The optical emitter 24 generates inspection light 111 and the light-guiding region 19 of the light guide 18 directs the inspection light 111 towards an ear region. This light is called inspection light because it interrogates the surface of the ear, penetrates the skin of the ear, and generates a scattered light  
10 response 110 which may effectively inspect blood vessels within the ear region. The optical detector 26 detects scattered light 110 from an ear region and the light-guiding region 19 of the light guide 18 guides the light to the optical detector 26 through the light-guiding region 19, as illustrated.

In the embodiment of Fig. 3, the light-guiding earbud 30 is  
15 configured for optical coupling that is parallel to the light guide (i.e., cover 18). The optical detector 26 and optical emitter 24 are configured to detect and generate light substantially parallel to the light-guiding region 19 of the light guide 18. For example, the light guide 18 defines an axial direction  $A_1$ . The optical emitter 24 and optical detector 26 are each oriented such that their  
20 respective primary emitting and detecting planes  $P_1$ ,  $P_2$  are each facing a respective direction  $A_3$ ,  $A_2$  that is substantially parallel with direction  $A_1$ .

The light guiding region 19 of the light guide 18 in the illustrated embodiment of Fig. 3 is defined by cladding material 21 that helps confine light within the light guiding region 19. The cladding material 21 may be reflective  
25 material in some embodiments. In other embodiments, the cladding material may be optically transparent or mostly transparent with a lower index of refraction than the light transmissive material of the cover 18. The cladding 21 may be a layer of material applied to one or more portions of the inner and/or outer  
30 surfaces 18a, 18b of the light guide 18. In some embodiments, the outer surface 16a of the earbud housing 16 may serve as cladding that confines light within the light-guiding region 19. In some embodiments, the light transmissive material of the light guide 18 may be composed of a material having a higher index of refraction than the cladding material 21. In some embodiments, air may serve as a cladding layer.

In the embodiment of Fig. 4A, the light-guiding earbud 30 is configured for optical coupling that is substantially perpendicular to the light guide (i.e., cover 18). The optical detector 26 and optical emitter 24 are configured to detect and generate light substantially perpendicular to the light-guiding region 19 of the light guide 18. For example, the light guide 18 defines an axial direction  $A_1$ . The optical emitter 24 and optical detector 26 are each oriented such that their respective primary emitting and detecting planes  $P_1$ ,  $P_2$  are each facing a respective direction  $A_3$ ,  $A_2$  that is substantially perpendicular to direction  $A_1$ . The orientation of the optical emitter 24 and optical detector 26 in Fig. 4A may be convenient for manufacturing purposes, where side-emitting LEDs and side-detecting photodetectors can couple directly to the light-guiding region 19 for generating light 111 and detecting light 110. This may relax size constraints for an earbud 30 because the dimensions of the light-guiding region 19 may be independent of the optical emitter 24 and optical detector 26.

Fig. 4B illustrates the light-guiding earbud 30 of Fig. 4A modified such that the earbud cover 18 and cladding material 21 are elongated to reach deeper within the ear canal C of a subject, and closer to the tympanic membrane, for example. In the illustrated embodiment of Fig. 4B, there are no apertures in the housing 16 or cover 18. Acoustic energy 44 from/to the speaker/microphone passes through the material of the cover 18 and housing 16. The illustrated elongated configuration serves as both an optical light-guiding region and an acoustic wave-guiding region.

Fig. 4C illustrates the light-guiding earbud 30 of Fig. 4A modified such that the earbud cover 18 and cladding material 21 are elongated to reach deeper within the ear canal C of a subject, and closer to the tympanic membrane, for example. In the illustrated embodiment of Fig. 4C, apertures 34a, 34b in the housing 16 and cover 18 are provided. As such, the optical light-guiding region 19 and the acoustic wave-guiding region 54 are isolated from each other. The light-guiding region 19 may be a light transmissive material, such as a dielectric material, and the acoustic wave-guiding region 54 may be air or another material, and the separation between these regions may be defined by at least part of the cladding material 21. Embodiments of the present invention may include multiple openings 34a, 34b in the housing 16 and cover 18. The separation between the light-guiding region 19 and the acoustic wave-

guiding region 54 may be defined by other structures composed of a variety of possible materials. Specific examples of these materials include plastic molding, metals, polymeric structures, composite structures, or the like.

5 Fig. 4D illustrates the light-guiding earbud 30 of Fig. 4A modified such that the earbud cover 18 and cladding material 21 are elongated to reach deeper within the ear canal C of a subject, and closer to the tympanic membrane, for example. In the illustrated embodiment of Fig. 4D, the area within the housing 16 may be air, silicone, plastic, or any material capable of passing sound. As such, at opening 34b, an interface exists between the material of the  
10 light-guiding region 19 and the material within the housing 16. In some embodiments, the light-guiding region 19 and the region within the housing 16 may both be air. In other embodiments, the light-guiding region 19 and the region within the housing 16 may be formed from the same or different materials. In some embodiments, the region within the housing 16 may be formed from an  
15 optical wave guiding material identical or similar to the material in the light-guiding region 19.

In the embodiments of Figs. 4B-4D, the optical energy 110 coming from the ear may include optical wavelengths, such as IR wavelengths, emitting from the tympanic membrane due to black body radiation. If the optical detector  
20 26 is configured to measure this black body radiation, then the earbud can be used to measure tympanic temperature, blood analyte levels, neurological, electrical activity, or metabolic activity of the earbud wearer.

Referring to Fig. 5, a light-guiding earbud 30 is configured for optical coupling that is parallel to the light guide (i.e., cover 18) as in the  
25 embodiment of Fig. 3. However, the embodiment of Fig. 5 does not include a separate earbud housing. Instead, the light guide 18 serves the function of the earbud housing. In addition, the light guide 18 includes multiple windows 18w formed in the cladding material 21 on the outer surface 18a of the cover and through which light 111 emitted by the light emitter 24 passes and multiple  
30 windows 18w through which scattered light 110 passes into the light guide 18 to be directed to the light detector 26. These openings 18w may extend circumferentially around the light guide 18 or may partially extend circumferentially around portions of the light guide 18. In some embodiments of this invention, the earbud housing and light guide 18 may be separated, as

shown in other figures.

In addition, the illustrated light guide 18 of Fig. 5 is surrounded by a layer 29 of light transmissive material. One or more lenses 29L are formed in this layer 29 and are in optical communication with respective windows 18w in the light guide 18. In the illustrated embodiment, a lens 29L is in optical communication with a respective window 18w through which emitted light 111 passes, and a respective window 18w through which scattered light 110 passes. Lenses 29L are configured to focus inspection light 111 onto a particular region of the ear. Lenses 29L are configured to help collect scattered light 110 and direct the scattered light 110 into the light guiding region 19. In some embodiments, these lenses 29L may be a molded part of the light guide 18. The illustrated location of lenses 29L in Fig. 5 is non-limiting, and the lenses 29L may be located wherever optical coupling between the earbud and ear is desired. Though convex lens embodiments are shown in Fig. 5, this is not meant to limit embodiments of the present invention. Depending on the desired optical coupling and configuration of the earbud against the ear, a variety of lens types and shapes may be useful, such as convex, positive or negative meniscus, planoconvex, planoconcave, biconvex, biconcave, converging, diverging, and the like.

Referring now to Fig. 6, a light guiding earbud 30, according to some embodiments of the present invention, includes a base 50, an earbud housing 16 extending outwardly from the base 50 that is configured to be positioned within an ear E of a subject, and a cover 18 of light transmissive material surrounding the earbud housing 16 that forms a light-guiding region 19. The earbud housing 16 is in acoustical communication with a speaker 22 and includes at least one aperture 34a through which sound from the speaker 22 can pass. The earbud housing 16 encloses the speaker 22, an optical emitter 24 and an optical detector 26 as illustrated. An additional light detector 26 is located on the base 50 but is not surrounded by the earbud housing 16.

The earbud housing 16 is formed of a cladding material. The cladding material may be reflective material in some embodiments. In other embodiments, the cladding material may be optically transparent or mostly transparent with a lower index of refraction than the light transmissive material of the cover 18. In some embodiments, the earbud housing 16 may be replaced by

air, such that the cladding region is air. Air may have a smaller index of refraction than that of the cover 18, supporting light transmission along the cover 18. In other embodiments, a cladding region exists between the earbud housing 16 and the light-guiding region 19. In another embodiment, a cladding region exists  
5 covering the outside of light-guiding region 19, with the exception of regions surrounding the lens regions 18L.

A plurality of windows 16w are formed in the earbud housing 16 at selected locations to permit light emitted by the light emitter 24 to pass  
10 therethrough. In some embodiments, the earbud housing 16 may have translucent or transparent material that serves the function of one or more windows 16w. The cover 18 includes a plurality of lenses 18L that are in optical communication with respective windows 16w in the earbud housing 16. These  
15 lenses 18L are configured to focus light 111 passing through a respective window 16w towards a particular region of the ear of a subject, and to help collect scattered light 110 and direct the scattered light 110 into the earbud housing 16 towards the light detector 26.

The earbud 30 of Fig. 6, via the locations of windows 16w, produces isotropic optical coupling, such that the light generated by the optical  
20 emitter 24 is roughly identical in all directions with respect to the earbud housing 16. The inspection light 111 generated by the optical emitter 24 passes isotropically into the light guiding region 19 through the windows 16w.

A benefit of light guiding earbud 30 of Fig. 6 is that manufacturing may not require alignment of the light-guiding region 19 with respect to the  
25 optical emitter 24 and detector 26. This may be in part because the optical energy density generated/detected by the optical emitter/detector may be the same, or relatively uniform, within the earbud housing 16 regardless of alignment of the light guide 18 with respect to the earbud housing 16 or regardless of  
30 alignment between the optical emitters/detectors and the earbud housing 16. This effect may be similar to that observed in "integrating spheres" commonly used for quantifying the lumen output of an optical source. Namely, because the light from the optical emitter 24 may be substantially isotropic and not focused, there is less restriction on the alignment of the earbud housing and earbud cover with respect to the optical emitter 24 or optical detector 26.

Referring now to Figs. 7A-7B, a light guiding earbud 30, according

to some embodiments of the present invention, includes a base 50, and an earbud housing 16 extending outwardly from the base 50 that is configured to be positioned within an ear E of a subject. The earbud housing 16 is formed from translucent material such that light can pass therethrough and forms a light-guiding region 19. The earbud housing 16 is in acoustical communication with a speaker 22 and includes at least one aperture 34a through which sound from the speaker 22 can pass. A pair of optical detectors 26 are secured to the base 50 but are not surrounded by the earbud housing 16, as illustrated.

The earbud housing 16 includes a flexible optical emitter 24 integrally formed within the housing 16, as illustrated. The optical emitter 24 is flexible such that it may be positioned around the earbud in an earbud form-factor. The flexible optical emitter 24 is configured to be conformable to an earbud shape and configuration. The flexible optical emitter 24 may be in, near, or part of the earbud housing 16, cladding material 21, or housing 16. In some embodiments, the flexible optical emitter 24 may be part of a flexible optical circuit inserted into an earbud 30.

The optical detectors 26 positioned outside the earbud housing 16 of the earbud 30 of Figs. 7A-7B collect scattered light from an ear originating from inspection light 111 generated by the flexible optical emitter 24. The flexible optical emitter 24 may be mounted to the earbud base 50 through one or more electrical connectors 24a. In some embodiments, these may be soldered, wired, or detachable connectors. In some embodiments, the flexible optical emitter 24 may include a flexible optical detector. In some embodiments, the flexible optical emitter 24 may be part of a flexible optical circuit comprising the form-factor of 24 shown in Figs. 7A-7B, where the flexible optical circuit may include one or more optical emitters and detectors as well as amplifiers, microprocessors, wireless circuitry, and signal conditioning electronics. In some embodiments, the flexible optical circuit may include a complete chipset for physiological and environmental detection and for wired/wireless transfer of data to a remote location. For example, these flexible devices may include an organic LED (OLED) and an organic optical detector circuit. This embodiment may be useful for generating a diffuse light beam towards the ear region and for detecting a diffuse optical scatter response from the ear region. In some embodiments, the emitter and detector on the flexible optical emitter 24 may be a traditional light-

emitting diode (LED) and photodetector (PD) integrated onto a flexible printed circuit board. In other embodiments, transparent solid state optical emitters, detectors, or switches may be used. For example, an electrically controlled liquid crystal matrix may be embedded within an earbud, covering the flexible optical emitter 24. This may allow localized control of light flow to selected areas from/to the earbud going towards/away-from the ear. Additionally, this may allow localized control of light wavelength to selected areas.

Referring now to Figs. 8A-8B, a light guiding earbud 30, according to some embodiments of the present invention, includes a base 50, an earbud housing 16 extending outwardly from the base 50 that is configured to be positioned within an ear of a subject, and a cover 18 that surrounds the earbud housing 16. The earbud housing 16 is in acoustical communication with a speaker 22 and includes at least one aperture 34a through which sound from the speaker 22 can pass. The cover 18 includes at least one aperture 34b through which sound from the speaker 22 can pass. The cover 18 includes a cladding material 21 on the outer surface 18a thereof, except at end portion 18f, as illustrated. In the illustrated embodiment, there is no cladding material on the cover inner surface 18b. The housing 16 is in contact with the cover inner surface 18b and serves as a cladding layer to define the light guiding region 19. The cover 18 with the illustrated cladding material 18c serves as a light guide that delivers light from the optical emitters 24 into an ear canal of a subject through cover end portion 18f. The cover 18 also collects light through end portion 18f and delivers the collected light to the optical detectors 26. Various configurations and arrangements of optical emitters and detectors may be utilized in accordance with embodiments of the present invention.

In the illustrated embodiment of Figs. 8A-8B, to reduce the risk of the inspection light 111 interrogating and saturating the optical detectors 26, a bottom portion 16a of the earbud housing 16 includes a light blocking region that blocks light from passing therethrough. This light blocking region 16a may be a black-painted region, an optically opaque region, or a material or structure that blocks light transmission. The illustrated configuration of the earbud housing 16 and bottom portion 16a may help confine inspection light 111 generated by the optical emitters 24 within the light-guiding layer (i.e., 19), guiding this light towards the ear region through the end portion 18f of the earbud 30.



In some embodiments, as illustrated in Fig. 8C, the earbud housing 16 may be at least partially reflective to scatter light within the cavity defined by the earbud housing 16. In such case, the optical energy 111 may exit the earbud 30 through apertures 34a, 34b in the housing 16 and cover 18. An advantage of this configuration is that light 111 can be focused on a particular region of the ear where a particular physiological activity may be located. Also, this configuration may reduce unwanted optical signals from regions that may not be relevant to the physiological activity of interest. Although Fig. 8C shows the apertures 34a, 34b positioned toward the tympanic membrane, the apertures 34a, 34b may be located at one or more other locations about the earbud 30. For example, an aperture may be formed in the housing 16 and cover 18 at the location where the earbud 30 contacts the antitragus of an ear to allow optical energy 111 to interrogate the antitragus region of the ear.

In some embodiments, as illustrated in Fig. 8D, the earbud housing 16 may contain a material that reflects one or more wavelengths of light and transmits one or more wavelengths of light. For example, the earbud housing 16 may be comprised of a polymer, plastic, glass, composite material, or resin that reflects visible wavelengths and transmits IR wavelengths. Exemplary materials include color absorbing materials, such as organic dyes, found in photographic film. Alternatively, the earbud housing 16 may include an optical filter region, such as a Bragg filter or other optical filter layer deposited on one or more sides of the housing region. If an optical detector 26' is configured to measure visible wavelengths only, then the optical energy detected by optical detector 26' may consist primarily of optical energy scattered from the earbud housing 16, and the optical energy detected by the optical detectors 26 may consist of optical energy scattered from the ear region. This configuration may be useful because the signal from the optical detector 26' may represent motion noise which may be removed from the signal derived from the optical detectors 26, which may contain physiological information and motion noise.

Referring now to Figs. 9A-9B, a light guiding earbud 30, according to some embodiments of the present invention, includes a base 50, an earbud housing 16 extending outwardly from the base 50 that is configured to be positioned within an ear of a subject, and a cover 18 surrounding the earbud housing 16. The earbud housing 16 is in acoustical communication with a

speaker 22 and includes at least one aperture 34a through which sound from the speaker 22 can pass. The cover 18 includes at least one aperture 34b through which sound from the speaker 22 can pass. A pair of optical emitters 24 are secured to the base 50 and are surrounded by the earbud housing 16, as  
5 illustrated. An optical detector 26 is secured to the base 50 and is not surrounded by the earbud housing 16, as illustrated. The cover 18 serves as a light guide that delivers light from the optical emitters 24 into an ear canal of a subject.

The light-guiding region 19 of the cover 18 is designed to diffuse  
10 light and/or to generate luminescence. In this embodiment, the light-guiding region 19 includes at least one optical scatter or luminescence region. The optical scatter or luminescence region may be located anywhere within the earbud in the optical path of the optical emitters 24, but preferably within or about the cladding layer itself. When inspection light 111 generated by the  
15 optical emitters 24 is scattered or by an optical scatter region, this light may form a more diffuse optical beam 111a that is more uniform across the earbud 30 than the inspection light 111 generated by the optical emitters 24. This diffused beam, having an intensity distribution being less sensitive to motion of the ear, may be useful in alleviating motion artifacts in the scattered light coming from the ear,  
20 such that the scattered light coming from the ear, measured by the optical detector 26, is more indicative of blood flow changes within blood vessels and less indicative of mouth movements and body motion. The optical scatter region within the light-guiding region 19 may be at least partially comprised of impurities or morphological differences within the light-guiding region. An example of such  
25 impurities may include point defects, volume defects, native defects, metallics, polymers, microspheres, phosphors, luminescent particles, air pockets, particles, particulate matter, and the like. An example of morphological differences may include density variations, roughness, air pockets, stoichiometry variations, and the like. As a specific example, the light-guiding region 19 may comprise a  
30 transparent material, such as glass, a polymer, or silicone, and a luminescent impurity, such as a phosphor or luminescent polymer or molecule, may be integrated within the light-guiding region. This configuration may generate luminescence within the light-guiding region 19 in response to optical excitation from the optical emitters 24. In other embodiments, nanoscale fluctuations or

impurities may be used to diffuse or manipulate light through the earbud. Examples of nanoscale fluctuations or impurities may include quantum dots, rods, wires, doughnuts, or the like.

5 Fig. 9C illustrates an exemplary homogeneous distribution of luminescent particles 44, such as phosphors, embedded within the earbud cover 18, according to some embodiments of the present invention. Figs. 9D-9E illustrate an exemplary distribution of luminescent particles 44, such as phosphors, where the particles are distributed near one or more surfaces of the earbud cover 18, according to some embodiments of the present invention.

10 In another embodiment, an optical scatter or luminescent region may be at least partially located in a separate region from the light-guiding region 19, such as a coating, that may be in physical contact with the light-guiding region 19.

15 In another embodiment, the optical scatter region or luminescent region may include multiple layers of light-guiding material having at least one dissimilar optical property, such as a dissimilar index of refraction, transparency, reflectivity, or the like. In another embodiment, the optical scatter region may include one or more patterned regions having at least one dissimilar optical property.

20 In another embodiment, the optical scatter or luminescent region may be distributed at select locations throughout the earbud.

25 Fig. 10 illustrates relevant anatomy of a human ear E. Blood vessels are located across the ear, but it has been discovered that photoplethysmography (PPG) signals are the strongest near the antitragus, tragus, lobule, and portions of the acoustic meatus, and the ear canal. The antitragus is a particularly attractive location for photoplethysmography because a strong PPG signal can be derived with minimal motion artifacts associated with running and mouth motion.

30 Referring now to Figs. 11A-11B, a light guiding earbud 30, according to some embodiments of the present invention, includes a base 50, an earbud housing 16 extending outwardly from the base 50 that is configured to be positioned within an ear of a subject, and a cover 18 surrounding the earbud housing 16. The earbud housing 16 is in acoustical communication with a speaker 22 and includes at least one aperture 34a through which sound from the

speaker 22 can pass. The cover 18 includes at least one aperture 34b through which sound from the speaker 22 can pass. The cover 18 serves as a light guide for directing light into an ear of a subject and defines a light-guiding region 19. The illustrated earbud 30 is configured to focus light towards the antitragus of the ear of a human. In the illustrated embodiment, there is no cladding material on the outer surface 18a or inner surface 18b of the cover 18. Air serves as a cladding layer at the outer surface 18a and the housing 16 serves as a cladding layer at the inner surface 18b. Air may serve as a sufficient cladding layer due to the index of refraction difference between air and the light guiding layer. Namely, the index of refraction of the light-guiding layer 19 may be more than that of air.

A sensor module 70 is located near the earbud periphery, as illustrated. This sensor module 70 is shown in more detail in Figs. 12a-12B, and is described below. Three benefits of locating the sensor module 70 near the periphery of the light-guiding earbud 30 are: 1) PPG signals near the antitragus are less corrupted by motion artifacts than are PPG signals in other blood-vessel-rich regions of the ear; 2) the sensor module 70 may be designed somewhat independently of the earbud 30, liberating earbud comfort maximization from PPG signal maximization; and 3) because design constraints may be liberated, sensors need not be located in the acoustic cavity (i.e., within the earbud housing 16), allowing sound to pass through the acoustic orifices 34a, 34b with minimal interference. In this embodiment, it may be beneficial to incorporate lenses within the cover 18, similar to the lenses 18L of Fig. 6. It may be beneficial to extend the light-guiding region 19 of the cover 18 near the location where the earbud 30 rests near the antitragus. This light-guide extension 19a serves as an additional light-coupling region and may improve optical coupling from the light-guiding region 19 to an ear region and/or improve optical coupling from an ear region to the light-guiding region 19, including the antitragus and portions of the acoustic meatus. This is because this extended light-guiding region 19a may provide skin contact between the light guiding layer 19 and the skin, providing better optomechanical stability and optical coupling. In this embodiment, light may couple into the extended light-guiding region 19a, from an optical emitter 24, and into the ear region. Similarly, light may couple from the ear region, into the extended light-guiding region 19a, and to the optical detector 26. This extended light-guiding region 19a may appear as a bulb or lens

near the bottom of the earbud cover 18.

Figs. 12A-12B illustrate respective opposite sides of a sensor module 70 that may be located near the periphery of an earbud 30, for example as illustrated in Figs. 11A-11B, according to some embodiments of the present invention. Sensor module 70 may include a number of electronic components capable of converting various forms of energy into an electrical signal and digitizing the signal. For example, the sensor module 70 may include light-emitting diodes, optical sensors, accelerometers, capacitive sensors, inertial sensors, mechanical sensors, electromagnetic sensors, thermal sensors, nuclear radiation sensors, biological sensors, and the like. In some embodiments, the optical emitters of this invention may be a combination of side-emitting, edge-emitting, or surface-emitting light-emitting diodes (LEDs) or laser diodes (LDs).

In the illustrated embodiment of Figs. 12A-12B, the sensor module 70 includes two sets of optical emitters 24a, 24b. The first set of optical emitters 24a may be side-emitters (or edge-emitters) that are located at the top of the module 70 and direct light towards the earbud tip (e.g., cover end portion 18f, Fig. 8A) and towards the acoustic meatus and/or ear canal of the ear. The second set of optical emitters 24b may be located near the middle of the module 70 and may direct light in a beam that is largely perpendicular to that of the side-emitters 24a. In this particular embodiment, a single optical emitter 24b is shown mounted on a circuit board 70c such that this optical emitter 24b directs light towards the antitragus, which is located largely perpendicular to the acoustic meatus.

The optical energy generated by these optical emitters 24a, 24b may be scattered by blood vessels in the ear. This scattered light may be at least partially captured by the optical detectors 26. This light may be digitized by an optical detector 26 itself or with other circuitry on the sensor module circuit board 70c. The light-guiding design of the aforementioned light-guiding earbuds 30 may direct light towards each of these detectors 26. For example, this may be accomplished via the light-guiding earbud 30, wherein a lens (e.g., 18L, Fig. 6) facilitates inspection light coupling from the optical emitters 24 into the ear region and facilitates scattered light coupling to the optical detectors 26 from the ear region. Additional sensor components 27a, 27b may be used to measure an orthogonal energy component, facilitate sensor analysis, and thus help generate

physiological assessments. For example, sensor components 27a, 27b may be thermal sensors for measuring the temperature of the inner ear (using the thermal sensors 27a facing the ear region) with respect to the outer ear (using the thermal sensor 27b facing away from the ear region). By subtracting the two measured digitized temperatures from these two sensors 27a, 27b, an indication of heat flow from the ear can be generated. This temperature differential may be mathematically related to metabolic rate. For example, this temperature differential may be directly proportional metabolic rate. These temperature sensors may include thermistors, thermopiles, thermocouples, solid state sensors, or the like. They may be designed to measure thermal conduction, convection, radiation, or a combination of these temperature components.

The earbud-facing side (Fig. 12B) of the sensor module 70 may include sensors that do not need to be located on the antitragus-facing side of the sensor module. For example, one or more inertial sensors 27c may be located on the earbud-facing side (Fig. 12B) of the sensor module 70. In a particular embodiment, the inertial sensor 27c may be a 3-axis accelerometer, and because this sensor does not need to optically couple with the ear region, a better use of sensor real estate may be to locate this sensor on the earbud-facing side of the sensor module 70. Additional optical emitters 24a, 24b may be located on the earbud-facing side to facilitate an optical noise reference. Namely, as the person wearing the earbud module 30 moves around, the interrogation light generated by the optical emitters 24a, 24b may be scattered off the earbud and be detected by optical detectors 27d. This scattered light intensity, phase, and/or frequency due to body motion may be proportional to the motion-related component of the scattered light intensity from the ear region. The motion-related component is the component due to the physical motion of the ear and not the component related to blood flow. Thus, the optical scatter signal collected by the detectors 27d may provide a suitable noise reference for an adaptive filter to remove motion artifacts from the scattered light from the ear region, generating an output signal that is primarily related to blood flow (which may be the desired signal). In the same token, the scattered light reaching the optical detectors 27d may be used to generate a measure of activity. The intensity, phase, and frequency of this scattered light may be related to physical activity. Sinusoidal variations of the heart rate waveform may be counted digitally, by

identifying and counting crests and peaks in the waveform, to generate an effective step count. Embodiments of the present invention, however, are not limited to the illustrated location of components in the sensor module 70. Various types and orientations of components may be utilized without limitation.

5                    Fig. 19 illustrates the optical interaction between the sensor module 70 of Figs. 12A-12B and the skin of a subject. The sensor module 70 is shown in a reflective pulse oximetry setup 80 where reflected wavelengths 110 are measured, as opposed to measuring transmitted wavelengths. The optical emitter and optical detector wavelengths for pulse oximetry and  
10 photoplethysmography may include ultraviolet, visible, and infrared wavelengths. In the illustrated embodiment, an optical source-detector assembly 71 is integrated into sensor module 70 to generate optical wavelengths 111 and monitor the resulting scattered optical energy 110. The optical source-detector assembly 71 contains one or more optical sources emitting one or more optical  
15 wavelengths, as well as one or more optical detectors detecting one or more optical wavelengths.

The epidermis 90, dermis 91, and subcutaneous 92 layers of skin tissue are shown in Fig. 19 for reference. The scattered optical energy 110 may be modulated in intensity by changes in blood flow in the blood vessels, changes  
20 in physical motion of the body, respiration, heart rate, and other physiological changes. In some cases, the scattered optical energy may be luminescent energy from the skin, blood, blood analytes, drugs, or other materials in the body.

As previously described, the optical scatter signal collected by the  
25 detectors 27d may provide a suitable noise reference for an adaptive filter to remove motion artifacts from the scattered light from the ear region, generating an output signal that is primarily related to blood flow (which may be the desired signal). This is because light detected by these detectors would come from light that has not been scattered by a physiological region but rather light that has  
30 been scattered from a region of the associated earpiece that may move along with the ear. Thus, the scattered light reaching the optical detectors 27d may be used to generate a measure of activity.

Fig. 13 illustrates the basic configuration of an adaptive noise cancellation scheme 200 for extracting a physiological signal from noise. The

two types of sensor inputs are represented by the terms "Channel A" and "Channel B". Channel A refers to inputs from sensors that collect physiological information plus noise information, and Channel B refers to inputs from sensors that collect primarily (or substantially) noise information. Channel B information is passed through an electronic filter 203 whose properties are updated adaptively and dynamically. The filter 203 properties are updated to minimize the difference between Channel A and the post-processed Channel B, denoted as  $B^{\wedge}$ . In this way, noise is removed from Channel A and Channel C contains predominantly physiological information from which parameters such as blood flow, heart rate, blood analyte levels, breathing rate or volume, blood oxygen levels, and the like may be calculated. It is important to note that the Channel A information can still be useful despite the presence of noise, and the noise information may still be utilized for the computation of relevant parameters. For instance, the residual noise information in Channel A may be extracted by a parameter estimator 201 and the output in Channel D may be one or more activity assessments or the like. Similarly, the raw noise channel, Channel B, may be post-processed by a parameter estimator 205 to extract activity assessments for Channel E. Activity assessments may include exertion, activity level, distance traveled, speed, step count, pace, limb motion, poise, performance of an activity, mastication rate, intensity, or volume, and the like. The noise cancellation scheme 200 may be integrated into the firmware of a microprocessor or the like.

Although the embodiment of Fig. 13 for cancelling motion noise has been presented for an earbud configuration, this does not limit the invention to earbuds. An element of the adaptive noise cancellation scheme 200 for cancelling motion noise with an optical noise source may be that the optical detectors (such as 27d) are configured such that they do not receive scattered light from a physiological region while the detectors are simultaneously receiving scattered light from a region that is moving in synchronization with the physiological region. Even the slightest physiological signal existing in the optical noise reference of Channel B may prevent the adaptive filter from working properly such that the physiological signal may inadvertently be removed altogether by the filter 203. Furthermore, although the noise source Channel B is described as an optical noise source, other forms of energy may be used in this invention. Namely, any inertial sensor input may constitute the input for Channel



B. More specifically, a sensor for measuring changes in capacitance along the earbud with respect to the ear may provide an inertial noise reference without also measuring physiological information. Similarly, an accelerometer may provide an inertial noise reference without also measuring physiological information. An inductive sensor may also provide an inertial noise reference without also measuring physiological information. For each noise source, a defining element may be that the noise source may be configured to measure physical motion only (or mostly) and not physiological information (such as blood flow, blood oxygen, blood pressure, and the like). The utility of an optical noise source is that because the optical signal Channel A and the optical noise Channel B have the same linearity response, the adaptive filter scheme 200 may be more effective than the case where the signal and noise channels operate via different forms of sensed energy. For example, the response linearity characteristics of an accelerometer sensor in response to inertial changes may not be the same as the response linearity characteristics of an optical sensor.

The adaptive noise cancellation scheme 200 for cancelling motion noise with an optical source (specifically an infrared LED) has been demonstrated in the laboratory, with a human wearing a light-guiding earbud while resting, jogging, and running over a treadmill, and various data summaries 300a-300d are presented in Figs. 14A-14D. The data was recorded by a chip and memory card embedded in an earbud 30, having electrical connectivity with the sensor module 70 within the earbud 30. The raw signal in low motion 300a and raw signal in high motion 300c may be equated with the signal of Channel A of Fig. 13. Similarly, the "blocked channel" in low motion 300b and "blocked channel" in high motion 300d may be equated with Channel B of Fig. 13. In this experiment, the "block channel" consisted of an optical noise source, wherein the optical noise source included an optical emitter-detector module such as 70 of Figs. 12A-12B. However, instead of being exposed to the ear, the optical emitter-detector module was covered with a layer of clear silicone that was then covered by black tape to prevent light from the emitter (such as 24a and 24b) from reaching the ear. Thus, scatter from the black tape was scattered back to the emitter-detector module through the silicone and sensed as motion noise by the detectors (such as 26 and 27d). In a sense, for this configuration, the optical channel to the human ear is "blocked", hence the term "blocked channel". The

purpose of the clear silicone below the black tape was to: 1) provide an unobstructed, transparent optical scatter path for the IR light and 2) provide motion sensitivity similar to that of human skin, as silicone has a vibration response that may be similar to that of human skin.

5 Figs. 14A-14D show that the raw signal in low motion 300a indicates blood flow pulses which can be translated as heart rate. This is because each blood flow pulse represents one heart beat. However, the raw signal in high motion 300c indicates measured mostly physical activity. This is evident by the fact that the high motion signal 300c matches the corresponding  
10 blocked channel signal 300d, and the blocked channel in high motion 300d was found to have a substantially identical beat profile with the measured steps/second of the runner.

Fig. 15 is a graph of processed physiological signal data from a headset having one or more light-guiding earbuds 30, according to some  
15 embodiments of the present invention. Specifically, Fig. 15 shows the analysis results 400 of the data summaries 300a-300d presented in Figs. 14A-14D of blood flow (y-axis) versus time (x-axis) following two data processing sequences to extract heart rate. One sequence incorporated the adaptive filtering process 200 of Fig. 13 as well as a beat finder processing step. The second sequence  
20 incorporated the beat finder processing step without the adaptive filtering process 200 of Fig. 13. The beat finder process counts each heart beat by monitoring the peaks and valleys of each pulse, such as the peaks and valleys shown in the graph 300a of Fig. 14A. As shown in Fig. 15, the beat finder was effective at measuring heart rate during resting and jogging. However, the beat  
25 finder alone was not sufficient for monitoring heart rate during running. This is because at high motion, the signal 300d (Fig. 14D) associated with footsteps is strong enough to overwhelm the smaller signal associated with heart rate, and so the motion-related contribution dominated the overall signal 300d. Thus, the beat finder cannot distinguish heart beats from footsteps. By employing the  
30 adaptive filtering process 200 (Fig. 13) before the beat finder process, the footstep motion artifacts during running were effectively removed from the sensor signal (Channel A of Fig. 13) such that the output signal (Channel C of Fig. 13) contained blood flow information with minimal motion artifacts. Thus, this output signal contained blood flow pulse signals that could then be "counted" by

the beat finder to generate an accurate heart rate assessment.

In the specific analysis results 400 of Fig. 15, a beat finder was employed, following the adaptive filter process 200 of Fig. 13, to count heart beats. A more general method 500 for extracting physiological information from sensor signals in the midst of noise is illustrated in Fig. 16. The first block (block 510) represents the pre-adaptive signal conditioning stage. This process may utilize a combination of filters to remove frequency bands outside the range of interest. For example, a combination of band-pass, low-pass, and/or high-pass filters (such as digital filters) may be used. The second block (block 520) represents an adaptive filtering process such as the process 200 described in Fig. 13. This process may utilize the pre-conditioned signals from block 510 as inputs into an adaptive filter that reduces motion or environmental artifacts and noise in the primary data channel. The third block (block 530) represents the parameter extraction stage. This process may utilize a combination of signal conditioning filters in addition to peak finding (such as beat finding) algorithms to calculate properties of interest (e.g. heart rate, blood flow, heart rate variability, respiration rate, blood gas/analyte level, and the like). The method 500 of Fig. 16 may be encoded in the firmware of a microprocessor (or similar electronics) to facilitate real-time processing of physiological information.

Fig. 17 is a block diagram that illustrates sensor signals being processed into a digital data string including activity data and physiological data using the method 500 of Fig. 16, according to some embodiments of the present invention. Optical detectors 26 and optical emitters 24 may include digitizing circuitry such that they may be connected serially to a digital bus 600. Data from the detectors 26 may be processed by a processor/multiplexer 602 to generate multiple data outputs 604 in a serial format at the output 606 of the processor 602. In some embodiments, the processing methods may involve one or more of the methods described in Figs. 13, 14A-14D, 15 and 16. The multiple data outputs 604 may be generated by the processor/multiplexer 602 by time division multiplexing or the like. The processor 602 may execute one or more serial processing methods, wherein the outputs of a plurality of processing steps may provide information that is fed into the multiplexed data outputs 604.

The multiplexed data outputs 604 may be a serial data string of activity and physiological information 700 (Fig. 18) parsed out specifically such

that an application-specific interface (API) can utilize the data as required for a particular application. The applications may use this data to generate high-level assessments, such as overall fitness or overall health. Furthermore, the individual data elements of the data string can be used to facilitate better  
5 assessments of other individual data elements of the data string. As a specific example, the Blood Flow data string may contain information on the first and second derivatives of each blood pulse. This information may be processed from a PPG signal by running the adaptively filtered heart rate signal through a slope-finder algorithm (such as a differentiator circuit). In another example, the filtered  
10 PPG signal may be run through an integration circuit to estimate blood volume over each blood pulse. This information may then be used to assess blood pressure and blood oxygen levels more accurately than a direct measurement of blood pressure or blood oxygen levels.

In some embodiments of the invention, new methods of generating  
15 physiological assessment algorithms are enabled. These new methods may be achieved by measuring each data output of the data output string 604 in real time while an earbud user is also wearing one or more benchmark sensors. Principal component analysis, multiple linear regression, or other statistical or machine learning techniques can then be used to generate statistical  
20 relationships between the data outputs 604 and high level assessments measured simultaneously by the benchmark sensors. These benchmark sensors may measure aerobic fitness level,  $VO_2$ max, blood pressure, blood analyte levels, and the like. The relationships between the earbud sensor and benchmark sensor readings may be translated as algorithms embedded in the  
25 earbud, wherein each algorithm generates at least one assessment for the earbud user. In some cases, Bland-Altman plots of the earbud-derived assessment value versus the benchmark value may be used to judge the effectiveness of the algorithm, and this information may then feedback into improving the said earbud-derived assessment algorithm. Examples of these  
30 assessments may include aerobic fitness level,  $VO_2$ max, blood pressure, blood analyte levels (such as blood glucose, oxygen, carbon monoxide, etc.), and the like.

In some cases, it may be important to remove the effects of ambient optical noise from the physiological signal of a light-guiding earbud 30.

In such cases, one or more optical detectors 26 may be configured to measure outdoor or ambient lighting, and this information may be fed back into the processor 602 (Fig. 17) to extract external optical noise from the physiological signal. For example, some optical detectors may be configured to measure light from the ear, whereas others may be configured to measure light from the ambient environment, such as sunlight, room light, headlights, or the like. This may be achieved by directing the optical detectors towards and away from the ear, respectively. In a specific example, the ambient light reaching the optical detectors 26 may generate an undesirable sinusoidal response on an optical detector that is configured to measure light from the ear. This undesirable sinusoidal noise response may be generated as an earbud user moves their head from side to side while running. Thus, Channel A of the adaptive filter 200 (Fig. 13) may include physiological information plus undesired ambient optical noise information. To remove this noise from the final output Channel C, the output of the optical detector configured to measure ambient optical noise may be an input (Channel B of Fig. 13) into the adaptive filter 200. In this way, ambient noise from Channel A may be removed to generate a mostly physiological signal in Channel C.

The optical detectors 26 and emitters 24 may be of multiple wavelengths, with the goal of providing specialized physiological information for each wavelength. Referring to Fig. 19, for example, violet or UV light may be used to measure motion-related aspects of the ear, as violet and UV light may not penetrate greatly through the skin of the ear. Green, red, and IR wavelengths may have deeper penetration and provide information on the blood vessels and blood analyte levels. Blue wavelengths may be particularly useful for gauging changes in the size of the blood vessels.

Embodiments of the present invention may be more generally applied to non-optical or mix-optical configurations. For example, one or more of the detectors 26 and emitters 24 may be mechanical, acoustical, electrical, gravimetric, or nuclear detectors and emitters, all providing physiological information to the processor 602 (Fig. 17). For example, an accelerometer or capacitor may be used as a detector 26 for the noise reference (Channel B) input of an adaptive filter running in real-time on the processor 602.

Referring to Fig. 20, a chipset 800 for use in light-guiding earbuds

30, according to some embodiments of the present invention, may include optical emitters, optical detectors, mechanical, acoustical, electrical, gravimetric, nuclear detectors, additional sensors, signal processing, power regulation, digital control, and input/output lines. The chipset 800 may include firmware for signal  
5 extraction and for generating physiological assessments from information derived from the sensors and noise sources. One benefit of the chipset configuration is that the chipset 800 may be fully or partially integrated and hence compact and scalable to a wide range of products. To be integrated with a light-guiding earbud 30, the chipset 800 may be aligned such that the sensor  
10 region has an exposed window to a subject's ear. For example, the chipset 800 may be attached to the earbud base 50 or an earbud sensor module 70 and aligned line-of-sight through an acoustic orifice of an earbud and/or through a transparent end portion of an earbud 30 (e.g., through end portion 18f of the earbud 30 of Figs. 8A-8B or 18w of Figs. 4 & 5).

15 A specific embodiment of a chipset 800 for a stereo headset, according to some embodiments of the present invention, is illustrated in Fig. 21. This stereo chipset 800 may be integrated into an electronic module that may be attached to a printed circuit board. In another configuration, this stereo chipset 800 may be integrated into 3 modules, wherein the right and left earbud sensors  
20 comprise two separate modules, embedded in right and left earbuds respectively, and wherein the remaining circuit elements comprise the main module.

According to other embodiments of the present invention, monitoring devices with light-guiding regions may be configured to be attached  
25 to earlobes, fingers, toes, other digits, etc. For example, Figs. 22A-22B illustrate a monitoring device 70 that is configured to fit over a finger F, for example, as a finger ring, according to some embodiments of the present invention. The illustrated monitoring device 70 includes a generally circular band capable of encircling a finger F of a subject, with a cylindrical outer body portion 72 and a  
30 generally cylindrical inner body portion 74 secured together in concentric relationship. The outer body portion may be formed from virtually any type of material and may have an ornamental configuration. In some embodiments, the outer body portion 72 may include a flex circuit containing various electronic components, such as a microprocessor, D/A converter, power source, power

regulator, and the like. However, in some embodiments, the outer body portion 72 may not be required and the circular band of the monitoring device 70 includes only the inner body portion 74 secured to the base 50 (described below).

5                   A base 50 is secured to the inner and outer body portions 74, 72 of the illustrated embodiment and may be similar to the base 50 described above with respect to Figs. 3, 4A-4D, 5, 6, 7A-7B, 8A-8D, 9A-9B, and 11A-11B. The base 50 provides support for one or more sensors. In the illustrated embodiment, the base 50 supports an optical emitter 24, an optical detector 26, and an optical  
10 noise detector 26'.

                  The inner body portion 74 includes light transmissive material similar to that of the cover 18 described above with respect to Figs. 3, 4A-4D, 5, 6, 7A-7B, 8A-8D, 9A-9B, and 11A-11B. In some embodiments, the inner body portion 74 is formed from a soft, resilient material, such as silicone, which  
15 deforms when a finger of a subject is inserted therethrough. However, various types of light transmissive materials may be utilized, without limitation.

                  A layer of cladding material 21 is applied to (or near) the outer surface 74a of the inner body portion 74 and a layer of cladding material 21 is applied to (or near) the inner surface 74b of the inner body portion 74, as  
20 illustrated, to define a light-guiding region 19. As such, the inner body portion 74 serves as a light guide that delivers light from the optical emitter 24 to the finger F of a subject at one or more predetermined locations and that collects light from the finger F and delivers the collected light to the optical detectors 26, 26'. In some embodiments, the cladding material 21 may be embedded within the inner  
25 body portion 74 adjacent to the outer surface 74a and inner surface 74b. In some embodiments, the outer body portion 72 may serve as a cladding layer adjacent to the inner body portion outer surface 74a.

                  In the illustrated embodiment, windows 74w are formed in the cladding material 21 and serve as light-guiding interfaces to the finger F. There  
30 may be any number of these windows, as may be required for sufficient optical coupling, and the windows 74w may include lenses such as those described above (e.g., lens 18L illustrated in Fig. 6), to focus light emitted by the optical emitter 24 onto one or more portions of a finger F and/or to focus collected light on the light detectors 26, 26'. Similarly, the windows 74w may include optical

filters to selectively pass one or more optical wavelengths and reflect and/or absorb other optical wavelengths.

In the illustrated embodiment, the light-guiding region 19 includes light blocking members 80 that isolate light emitter 24 and light detector 26 from each other. In some embodiments, only a single light blocking member 80 may be utilized. For example, a single light blocking member 80 may be positioned between the light emitter 24 and light detector 26. By adding an additional blocking member 80, as illustrated, the only light reaching the optical detector 26 may be light passing through at least one portion of the finger.

In some embodiments, multiple light emitters 24 may be utilized. For example, light emitters of different wavelengths may be utilized. In some embodiments, multiple light detectors may be utilized that are configured to measure light at different wavelengths (e.g., light detectors 26 and 26' may be configured to measure light at different wavelengths). In this way, either optical detector may be configured to measure light mostly due to motion (such as finger motion) or to measure light mostly due to physiological processes and motion. For example, if the windows 74w incorporate IR-pass filters, visible light will not pass through the windows 74w and the light will be scattered to the photodetectors 26 and 26'. Or, if the two illustrated blocking regions 80 are in place, and if photodetector 26' is configured to measure only visible light and photodetector 26 is configured to measure only IR light, then only the photodetector 26' will detect scattered visible light. As this visible scattered light cannot reach the finger, the scatter intensity measured by optical detector 26' may be indicative of motion and not physiological activity.

Referring now to Fig. 23, a monitoring device 70', according to some embodiments of the present invention, may be configured to be attached to a body of a subject as a bandage or "band-aid". The illustrated monitoring device 70' includes an outer layer or body portion 72 and an inner layer or body portion 74 secured together, as illustrated. The outer body portion may be formed from virtually any type of material and may have an ornamental configuration. In some embodiments, the outer body portion 72 may include a flex circuit containing various electronic components, such as a microprocessor, D/A converter, power source, power regulator, and the like. However, in some embodiments, the outer body portion 72 may not be required and the monitoring



device 70' includes only the inner body portion 74 secured to the base 50 (described below).

5 A base 50 is secured to the inner and outer body portions 74, 72 and may be similar to the base 50 described above with respect to Figs. 3, 4A-4D, 5, 6, 7A-7B, 8A-8D, 9A-9B, and 11A-11B. The base 50 provides support for one or more sensors. In the illustrated embodiment, the base 50 supports an optical emitter 24, an optical detector 26, and an optical noise detector 26'.

10 The inner body portion 74 is formed of light transmissive material similar to that of the cover 18 described above with respect to Figs. 3, 4A-4D, 5, 6, 7A-7B, 8A-8D, 9A-9B, and 11A-11B. In some embodiments, the inner body portion 74 is formed from a soft, resilient material, such as silicone, which deforms when the device is attached to the body of a subject. However, various types of light transmissive materials may be utilized, without limitation.

15 A layer of cladding material 21 is applied to (or near) the outer surface 74a of the inner body portion 74 and a layer of cladding material 21 is applied to (or near) the inner surface 74b of the inner body portion 74, as illustrated, to define a light-guiding region 19. As such, the inner body portion 74 serves as a light guide that delivers light from the optical emitter 24 to the body of a subject at one or more predetermined locations and that collects light from the body and delivers the collected light to the optical detectors 26, 26'. In some  
20 embodiments, the cladding material 21 may be embedded within the inner body portion 74 adjacent to the outer surface 74a and inner surface 74b. In some embodiments, the outer body portion 72 may serve as a cladding layer adjacent to the inner body portion outer surface 74a.

25 In the illustrated embodiment, windows 74w are formed in the cladding material 21 and serve as light-guiding interfaces to the body of a subject. There may be any number of these windows, as may be required for sufficient optical coupling, and the windows 74w may include lenses such as those described above (e.g., lens 18L illustrated in Fig. 6), to focus light emitted  
30 by the optical emitter 24 onto one or more portions of the body of a subject and/or to focus collected light on the light detectors 26, 26'. Similarly, the windows 74w may include optical filters to selectively pass one or more optical wavelengths and reflect and/or absorb other optical wavelengths.

In the illustrated embodiment, the light-guiding region 19 includes a

light blocking member 80 that isolates light emitter 24 and light detector 26 from each other. In some embodiments, multiple light emitters 24 may be utilized. For example, light emitters of different wavelengths may be utilized. In some embodiments, multiple light detectors may be utilized that are configured to  
5 measure light at different wavelengths (e.g., light detectors 26 and 26' may be configured to measure light at different wavelengths).

The illustrated monitoring device 70' may be removably attached to the body of a subject via adhesive on one or more portions of the device 70'. In some embodiments, adhesive may be on the inner body portion 74. In  
10 embodiments where the outer body portion is utilized, the adhesive may be on the outer body portion 74. In some embodiments, the illustrated device 70' may be removably attached to the body of a subject via tape or other known devices.

The foregoing is illustrative of the present invention and is not to be construed as limiting thereof. Although a few exemplary embodiments of this  
15 invention have been described, those skilled in the art will readily appreciate that many modifications are possible in the exemplary embodiments without materially departing from the teachings and advantages of this invention. Accordingly, all such modifications are intended to be included within the scope of this invention as defined in the claims. The invention is defined by the  
20 following claims, with equivalents of the claims to be included therein.

THAT WHICH IS CLAIMED IS:

1. A method of generating a data string containing physiological and motion-related information, the method comprising:
  - sensing physical activity of a subject via at least one motion sensor attached to the subject;
  - sensing physiological information from the subject via at least one photoplethysmography (PPG) sensor attached to the subject; and
  - processing signals from the at least one motion sensor and signals from the at least one PPG sensor into a serial data string of physiological information and motion-related information, wherein a plurality of subject physiological parameters can be extracted from the physiological information, and wherein a plurality of subject physical activity parameters can be extracted from the motion-related information.
2. The method of Claim 1, wherein the plurality of subject physical activity parameters that can be extracted from the motion-related information comprise at least two of the following: exertion, activity level, distance traveled, speed, step count, steps/second, pace, limb motion, poise, performance of an activity, mastication rate, mastication intensity, and mastication volume.
3. The method of Claim 1, wherein the plurality of subject physiological parameters that can be extracted from the physiological information comprise at least two of the following: blood flow, blood pulse volume, heart rate, blood analyte levels, breathing rate or volume, blood oxygen levels, blood pressure,  $VO_{2max}$ , the 1st derivative of at least one blood pulse, and the 2nd derivative of at least one blood pulse.
4. The method of Claim 1, wherein the serial data string is parsed out such that an application-specific interface (API) can utilize the physiological information and motion-related information for an application.
5. The method of Claim 4, wherein the application is

configured to generate statistical relationships between subject physiological parameters and subject physical activity parameters in the physiological information and motion-related information.

6. The method of Claim 5, wherein the application is configured to generate statistical relationships between subject physiological parameters and subject physical activity parameters via at least one of the following: principal component analysis, multiple linear regression, machine learning, and Bland-Altman plots.

7. The method of Claim 1, further comprising filtering subject motion noise from the signals from the at least one PPG sensor prior to processing signals from the at least one motion sensor and signals from the at least one PPG sensor into the serial data string.

8. The method of Claim 7, wherein the subject motion noise comprises subject footstep noise.

9. The method of Claim 7, wherein filtering subject motion noise from the signals from the at least one PPG sensor comprises at least one of the following: FIR (Finite Impulse Response) filtering, IIR (Infinite Impulse Response) filtering, adaptive filtering, phase filtering, and frequency filtering.

10. The method of Claim 1, wherein the at least one motion sensor comprises at least one of the following: an optical sensor, an inertial sensor, an electrically conductive sensor, a capacitive sensor, an inductive sensor, an accelerometer, and a blocked channel sensor.

11. The method of Claim 1, wherein the at least one PPG sensor comprises at least one optical emitter, at least one optical detector, and at least one light guide.

12. The method of Claim 1, wherein the at least one motion sensor and the at least one PPG sensor are integrated into a wearable device.

13. The method of Claim 12, wherein the wearable device is configured to be attached to the subject at one or more of the following body locations: an ear, a limb, the nose, and a digit.

14. The method of Claim 1 wherein the physiological information and/or motion-related information comprises information on data integrity.

15. A wearable device, comprising:  
a housing; and  
a chipset enclosed within the housing, the chipset comprising at least one PPG sensor, at least one motion sensor, and at least one signal processor;

wherein the housing comprises at least one window that optically exposes the at least one PPG sensor to a body of a subject wearing the device.

16. The device of Claim 15, further comprising at least one light guide in optical communication with the at least one PPG sensor and the window.

17. The device of Claim 15, wherein the wearable device is an earbud.

18. The device of Claim 15, wherein the wearable device is a headset.

19. The device of Claim 15, wherein the at least one signal processor is configured to process signals from the at least one motion sensor and signals from the at least one PPG sensor into a serial data string of physiological information and motion-related information, wherein a plurality of subject physiological parameters can be extracted from the physiological information, and wherein a plurality of subject physical activity parameters can be extracted from the motion-related information.

20. The device of Claim 15, wherein the plurality of subject physical activity parameters that can be extracted from the motion-related information comprise at least two of the following: exertion, activity level, distance traveled, speed, step count, steps/second, pace, limb motion, poise, performance of an activity, mastication rate, mastication intensity, and mastication volume; and

wherein the plurality of subject physiological parameters that can be extracted from the physiological information comprise at least two of the following: blood flow, blood pulse volume, heart rate, blood analyte levels, breathing rate or volume, blood oxygen levels, blood pressure,  $VO_{2max}$ , the 1st derivative of at least one blood pulse, and the 2nd derivative of at least one blood pulse.

21. The device of Claim 19, wherein the at least one processor is configured to filter subject motion noise from the signals from the at least one PPG sensor prior to processing signals from the at least one motion sensor and signals from the at least one PPG sensor into the serial data string.

22. The device of Claim 21, wherein the subject motion noise comprises subject footstep noise.

23. The device of Claim 21, wherein the at least one processor is configured to filter subject motion noise from the signals from the at least one PPG sensor via at least one of the following: FIR (Finite Impulse Response) filtering, IIR (Infinite Impulse Response) filtering, adaptive filtering, phase filtering, and frequency filtering.

24. The device of Claim 15, wherein the at least one motion sensor comprises at least one of the following: an optical sensor, an inertial sensor, an electrically conductive sensor, a capacitive sensor, an inductive sensor, an accelerometer, and a blocked channel sensor.

### ABSTRACT OF THE DISCLOSURE

A method of generating a data string containing physiological and motion-related information includes sensing physical activity of a subject via at least one motion sensor attached to the subject, sensing physiological information from the subject via at least one photoplethysmography (PPG) sensor attached to the subject, and processing signals from the at least one motion sensor and signals from the at least one PPG sensor into a serial data string of physiological information and motion-related information. A plurality of subject physiological parameters can be extracted from the physiological information, and a plurality of subject physical activity parameters can be extracted from the motion-related information. The serial data string is parsed out such that an application-specific interface can utilize the physiological information and motion-related information for an application that generates statistical relationships between subject physiological parameters and subject physical activity parameters in the physiological information and motion-related information.

1463284

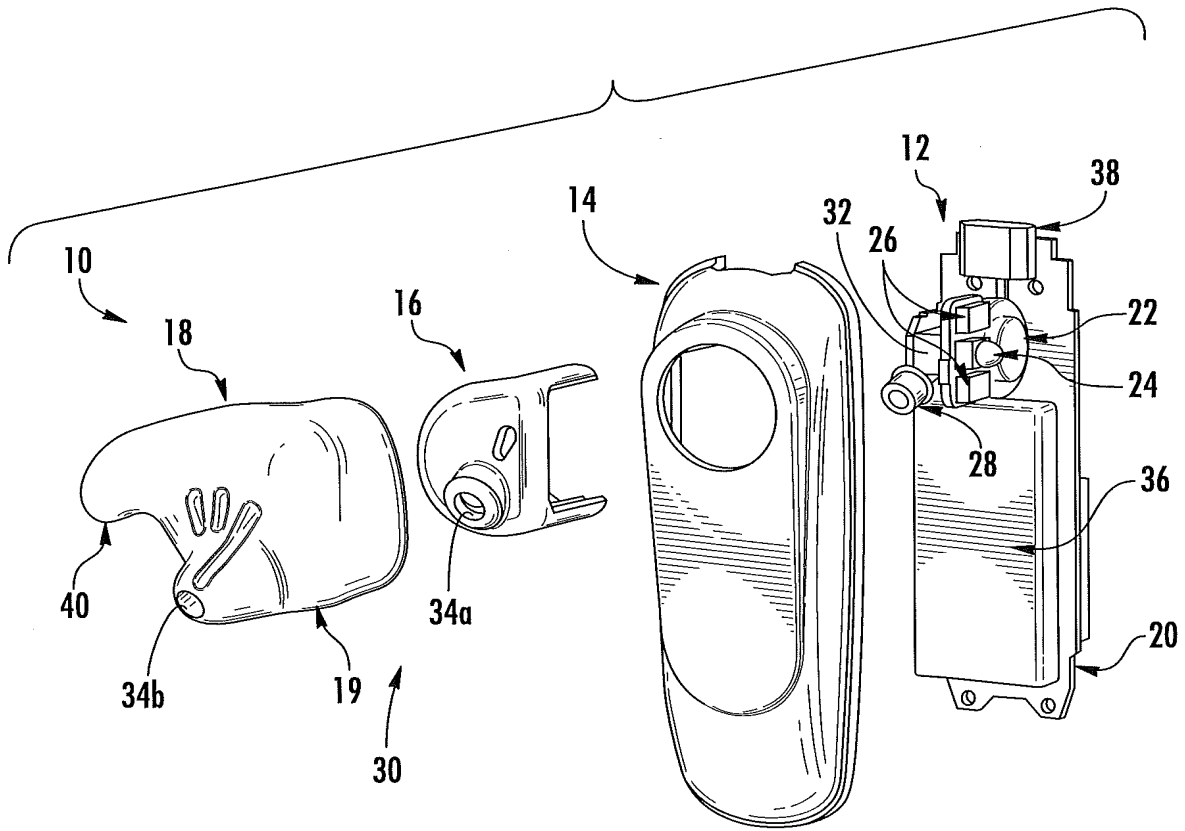

FIG. 1

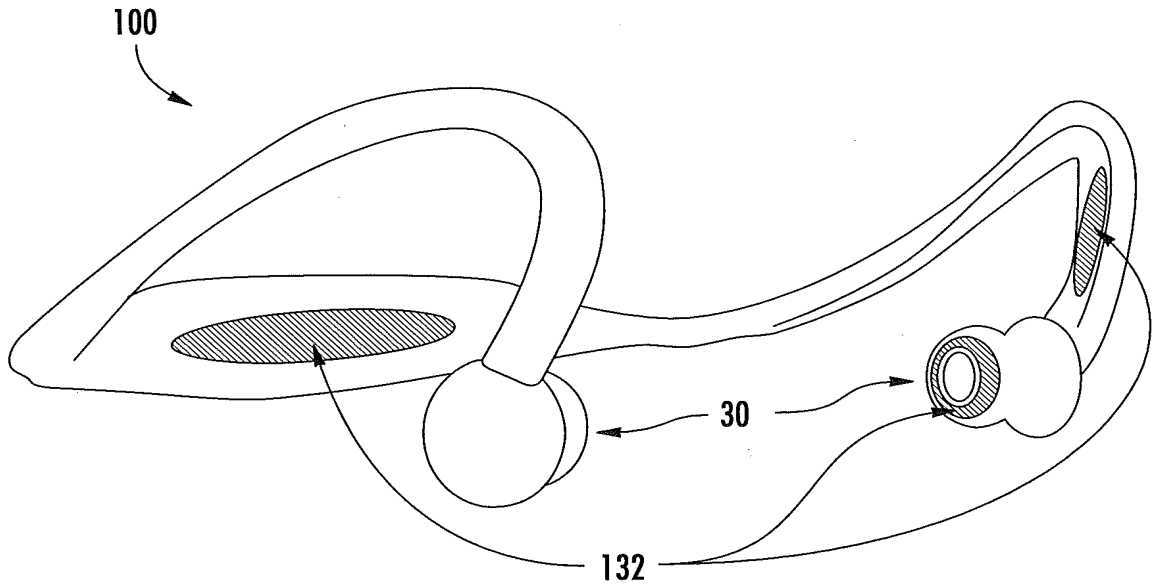

FIG. 2



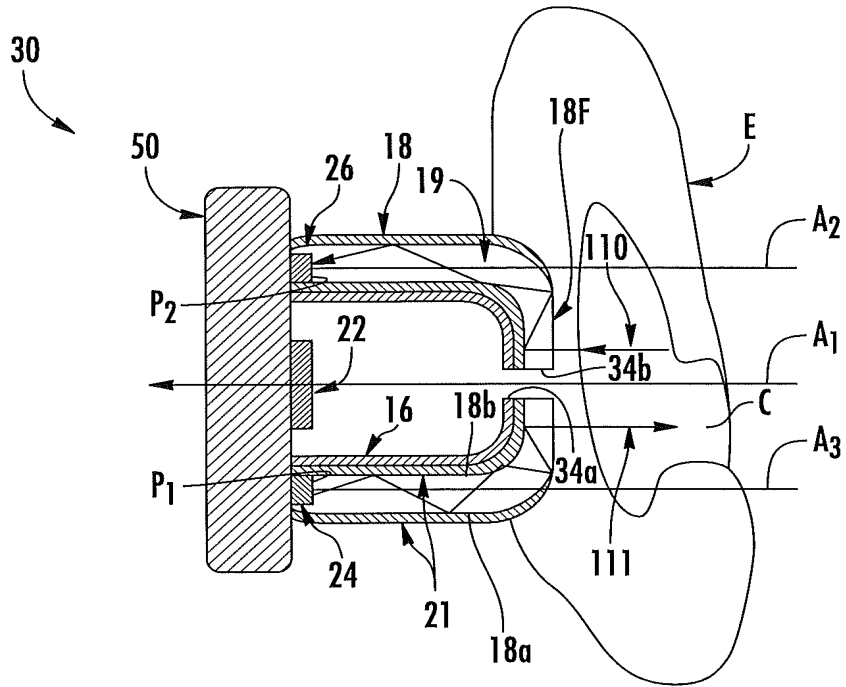

FIG. 3

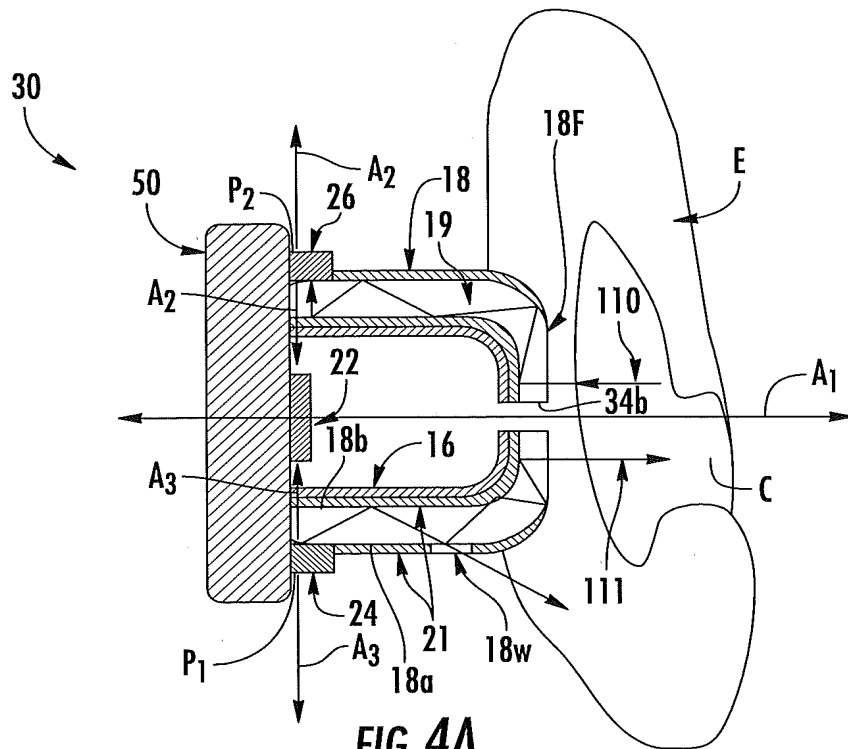

FIG. 4A

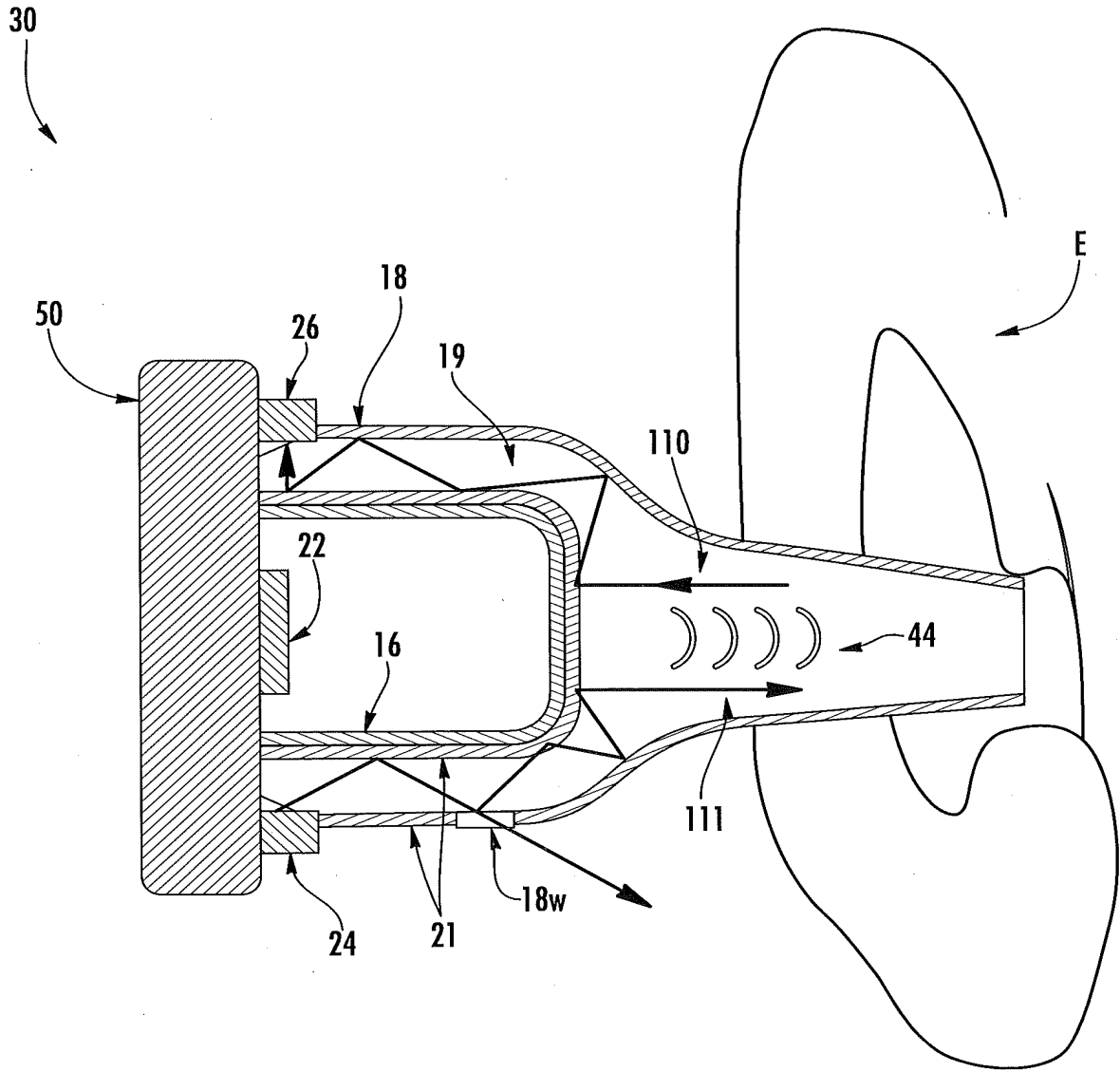

FIG. 4B

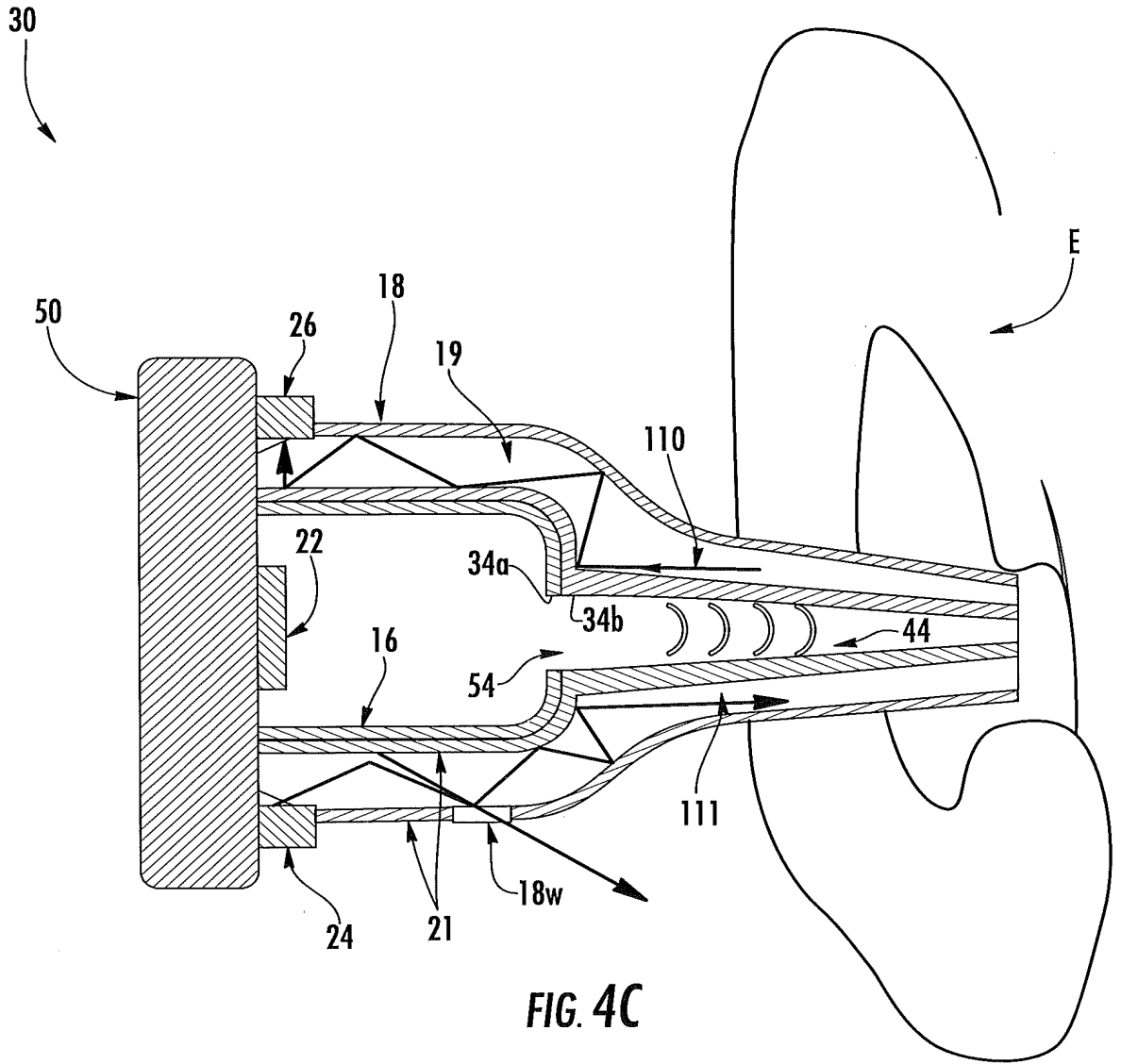

FIG. 4C

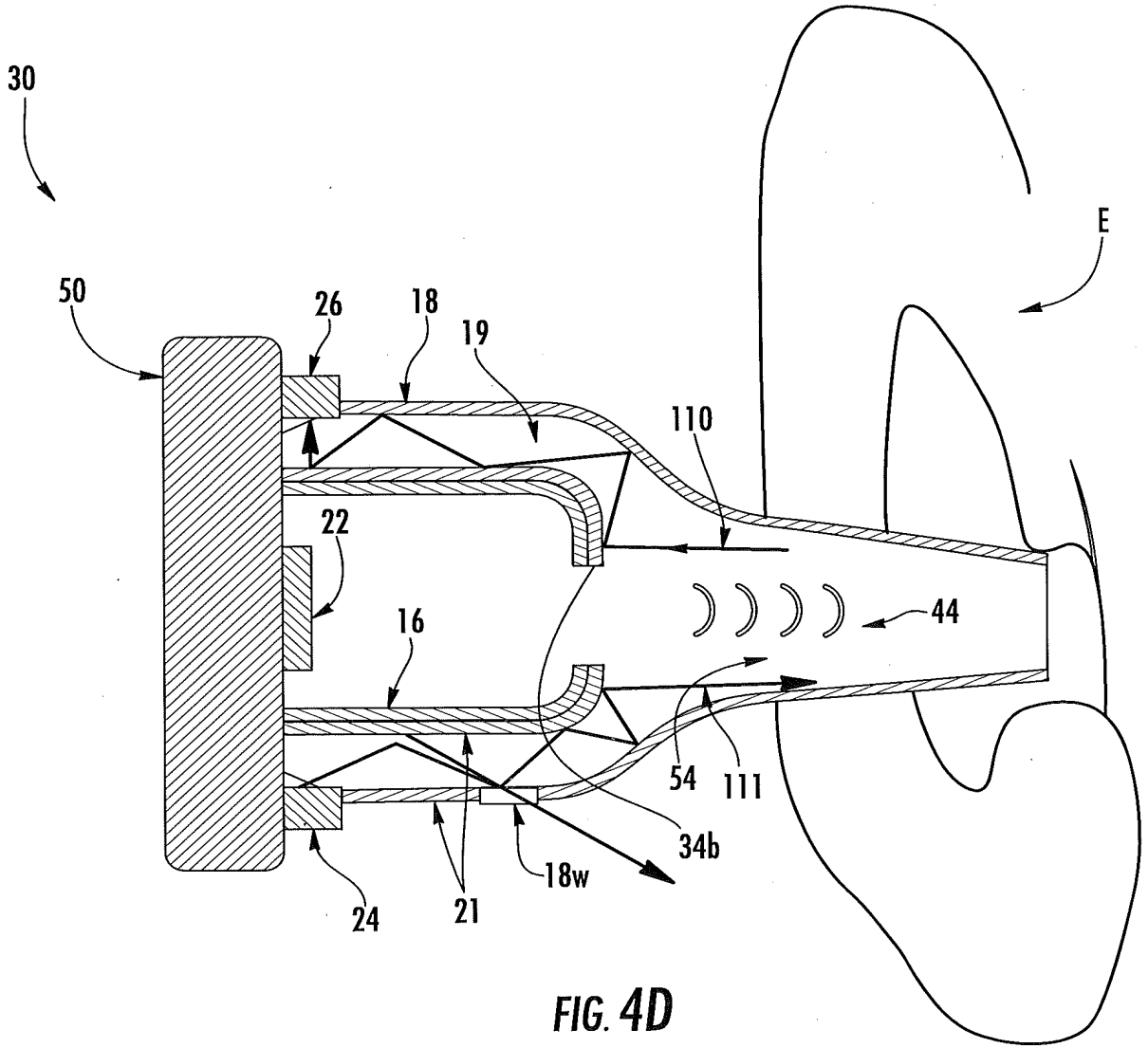

FIG. 4D



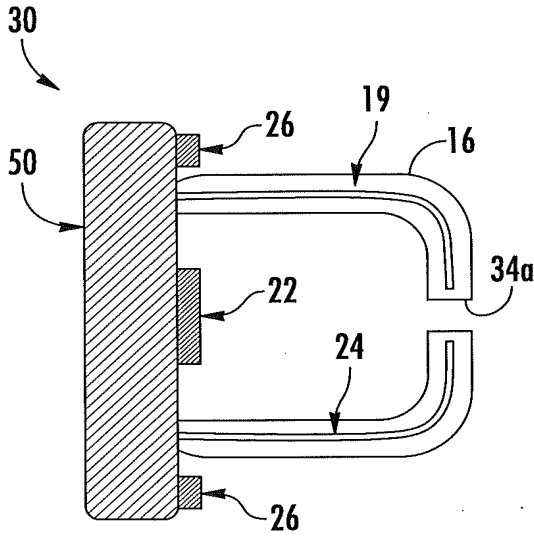

FIG. 7A

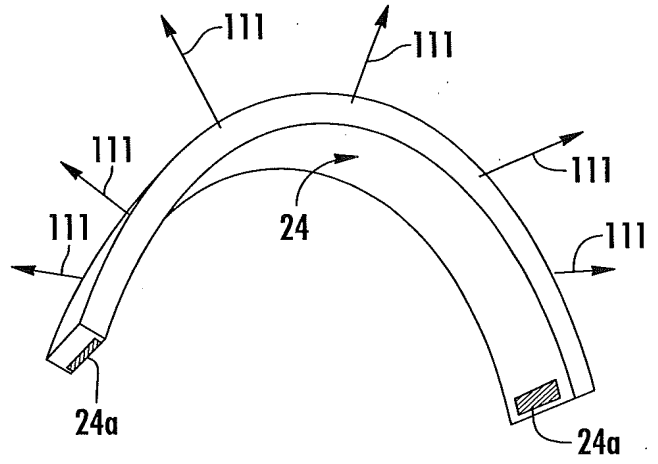

FIG. 7B

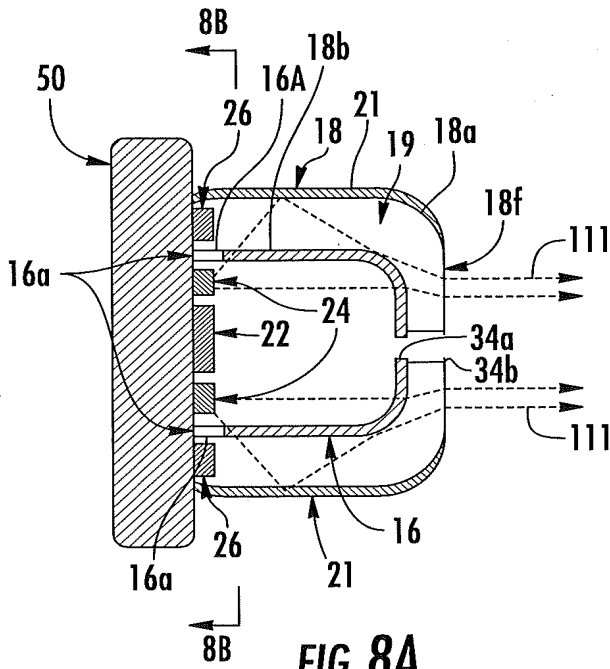

FIG. 8A

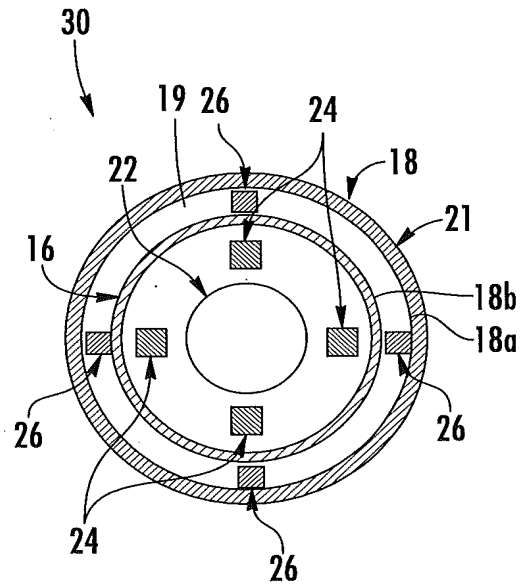
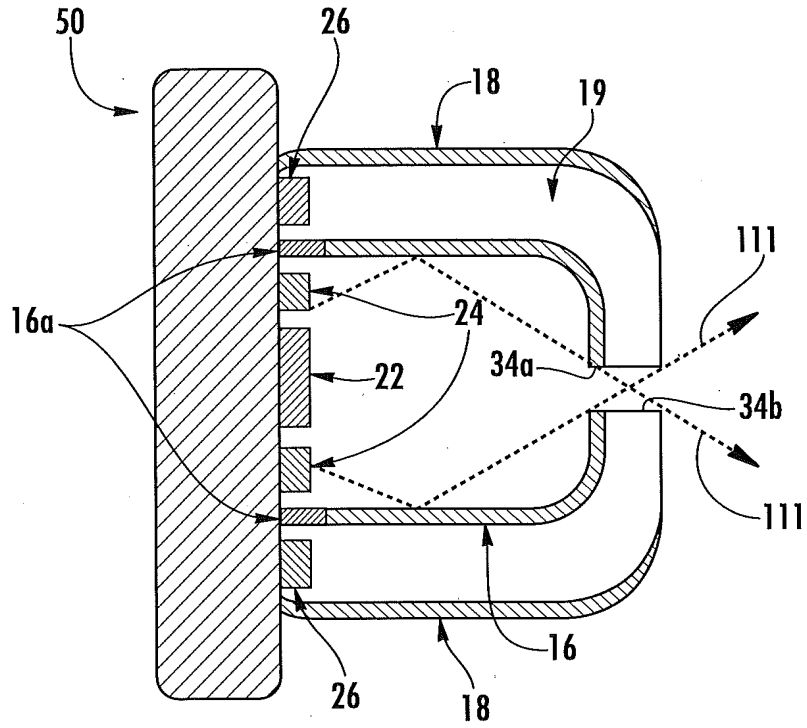
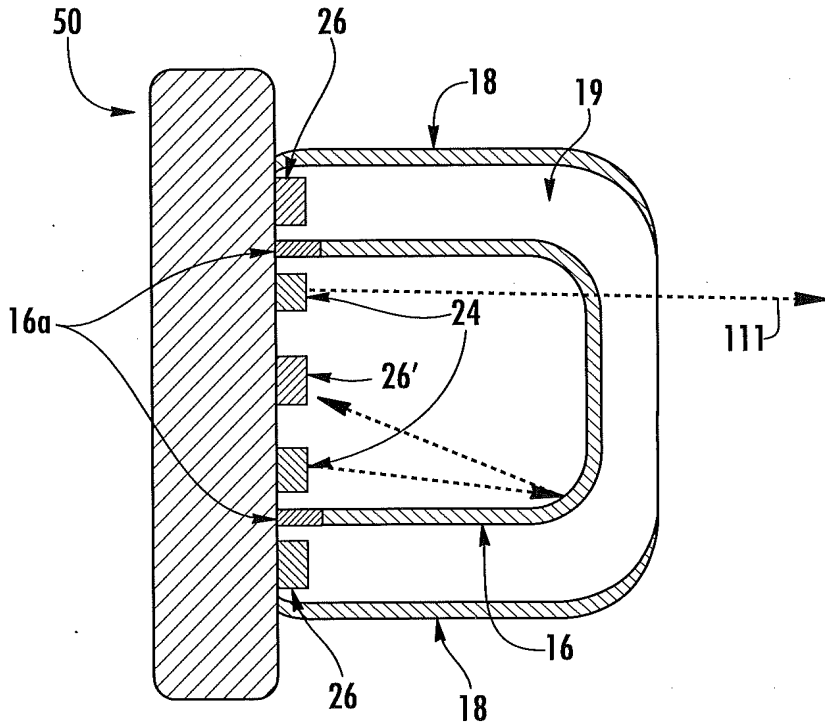

FIG. 8B



**FIG. 8C**

9/21



**FIG. 8D**



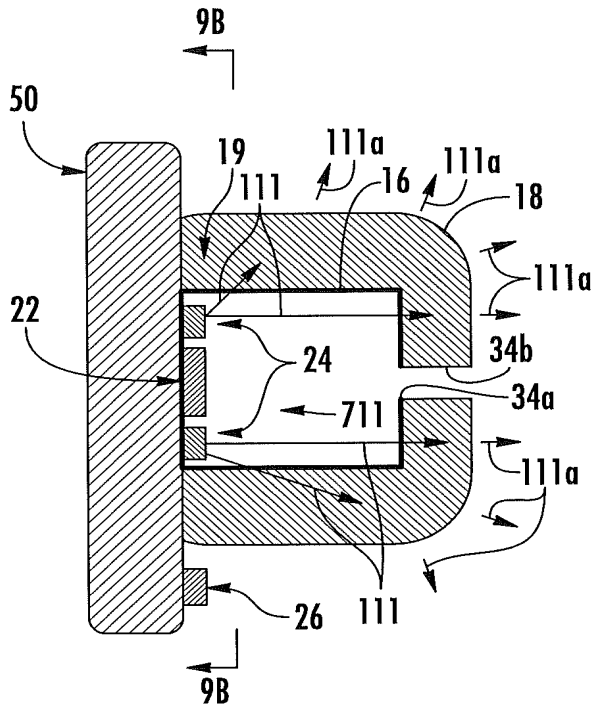

FIG. 9A

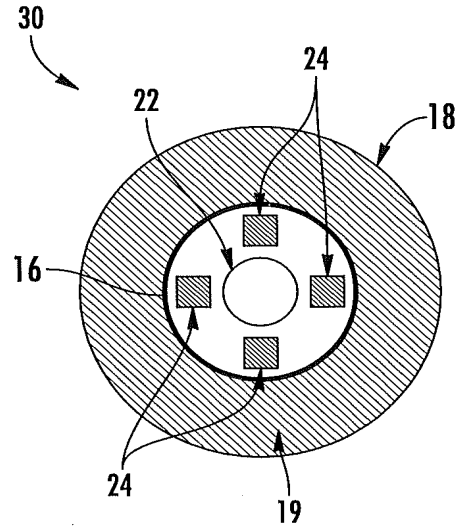

FIG. 9B

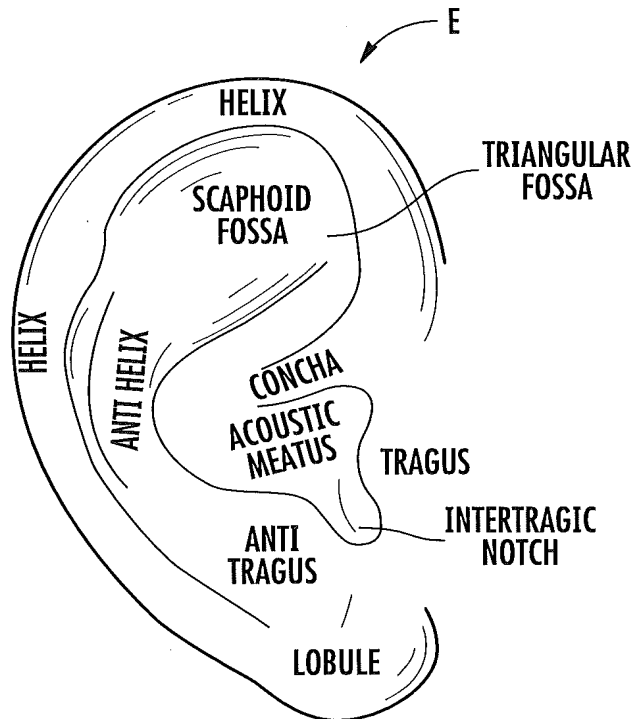
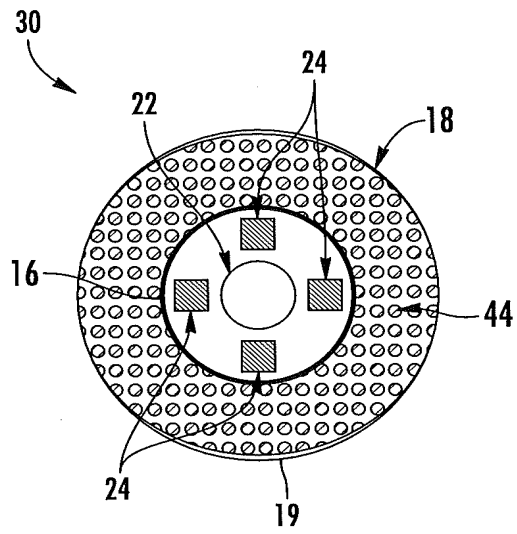

FIG. 10



**FIG. 9C**

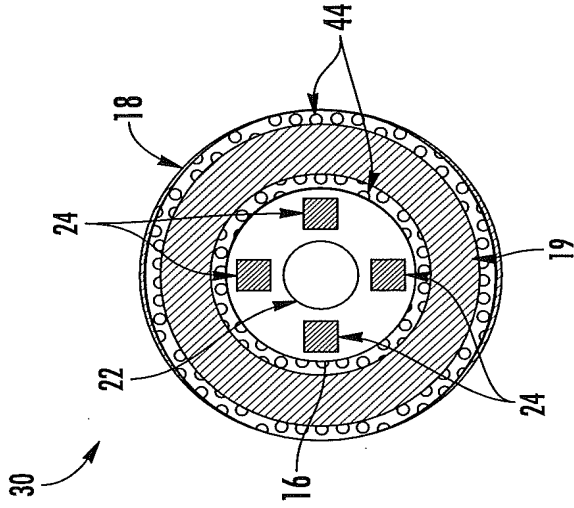

FIG. 9E

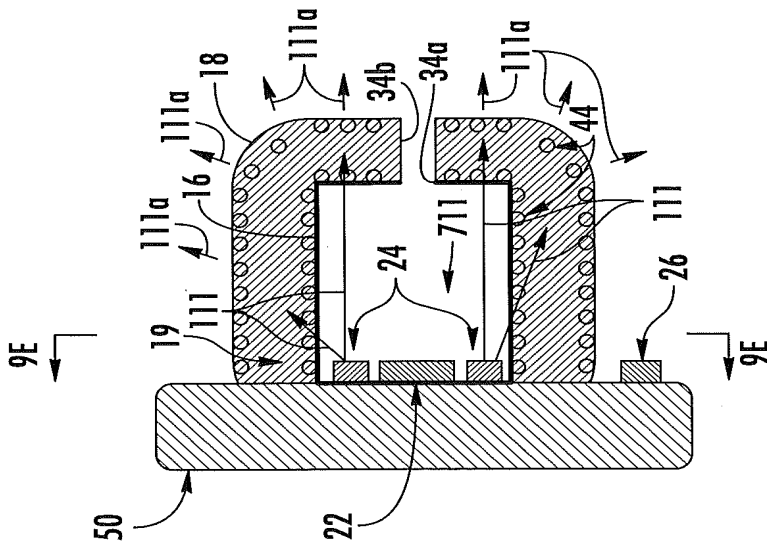

FIG. 9D

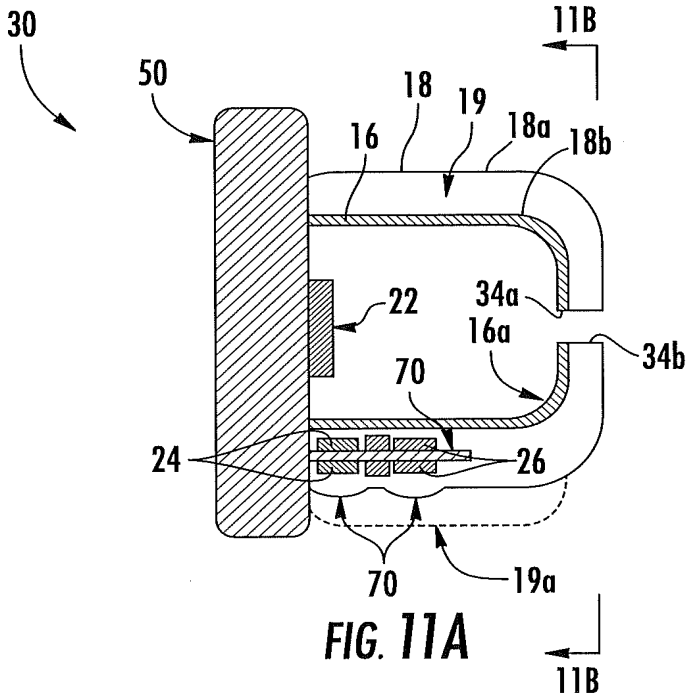

FIG. 11A

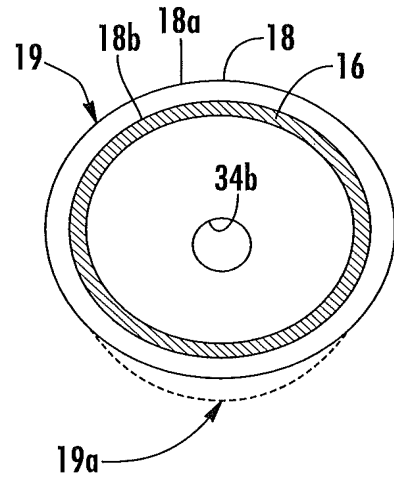
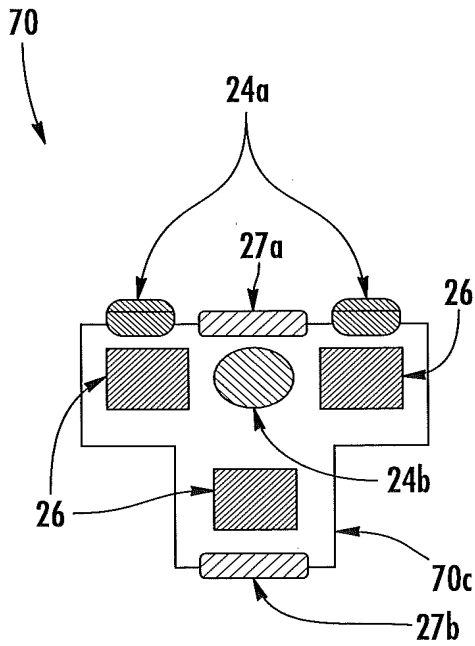
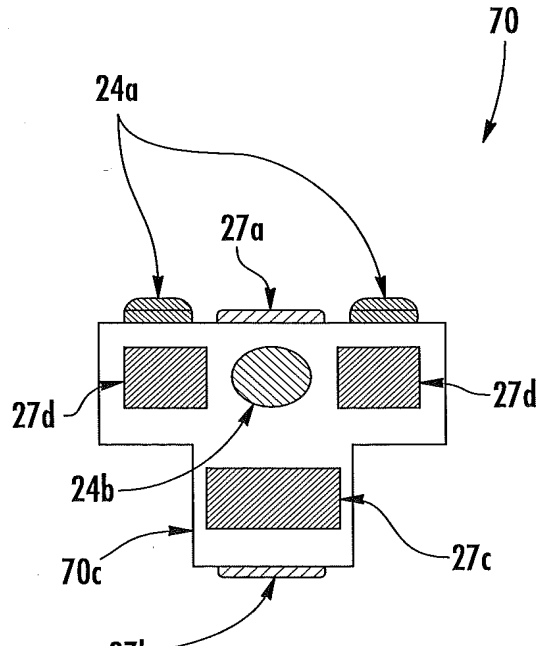

FIG. 11B



FACING ANTITRAGUS  
FIG. 12A



FACING EARBUD  
FIG. 12B

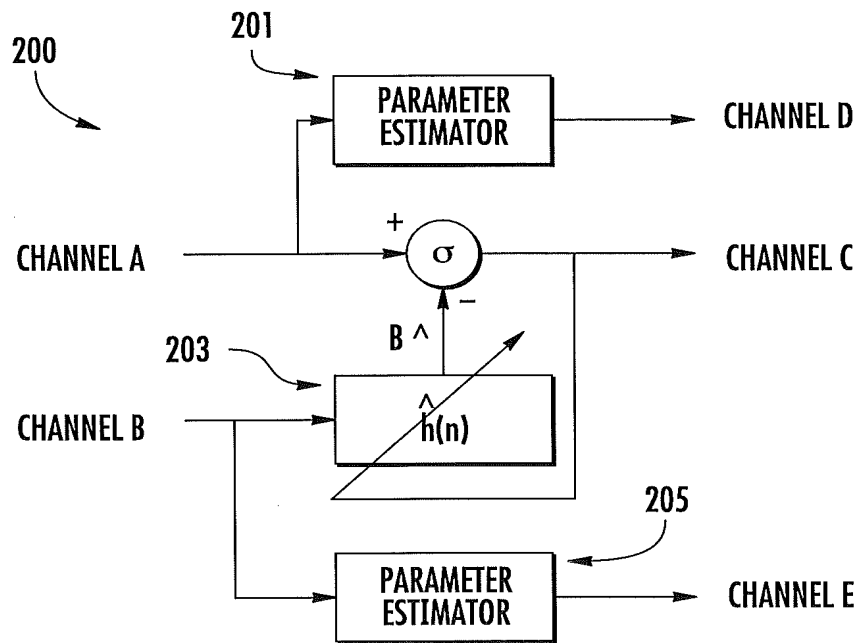

FIG. 13

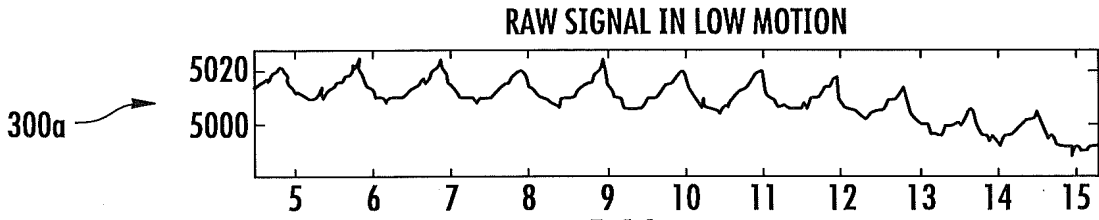

FIG. 14A

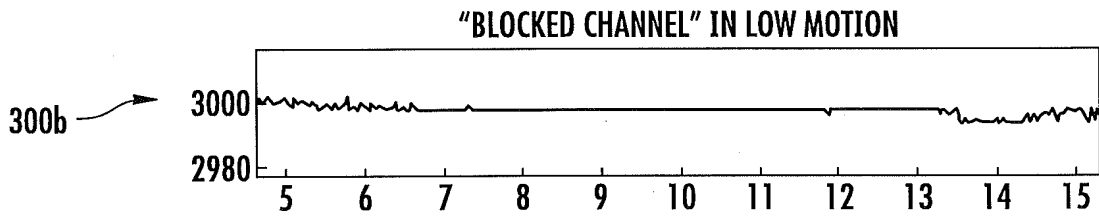

FIG. 14B

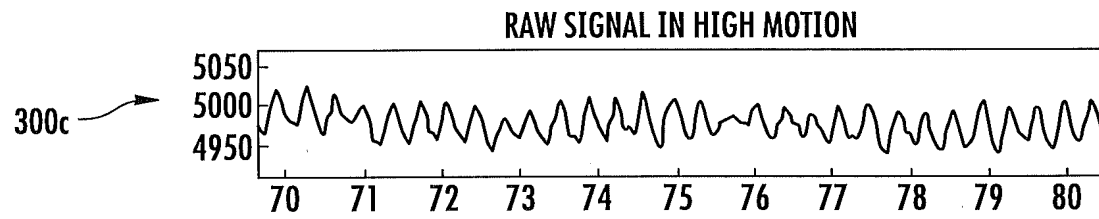

FIG. 14C

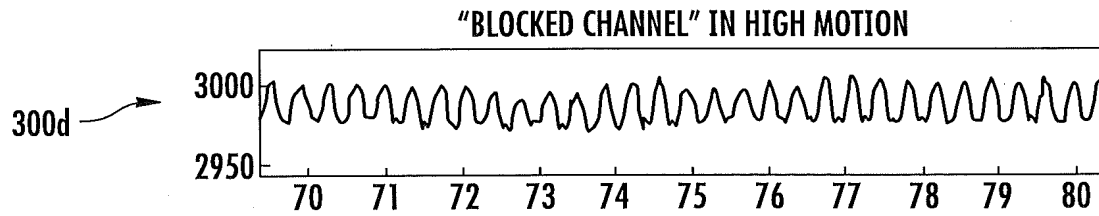

FIG. 14D

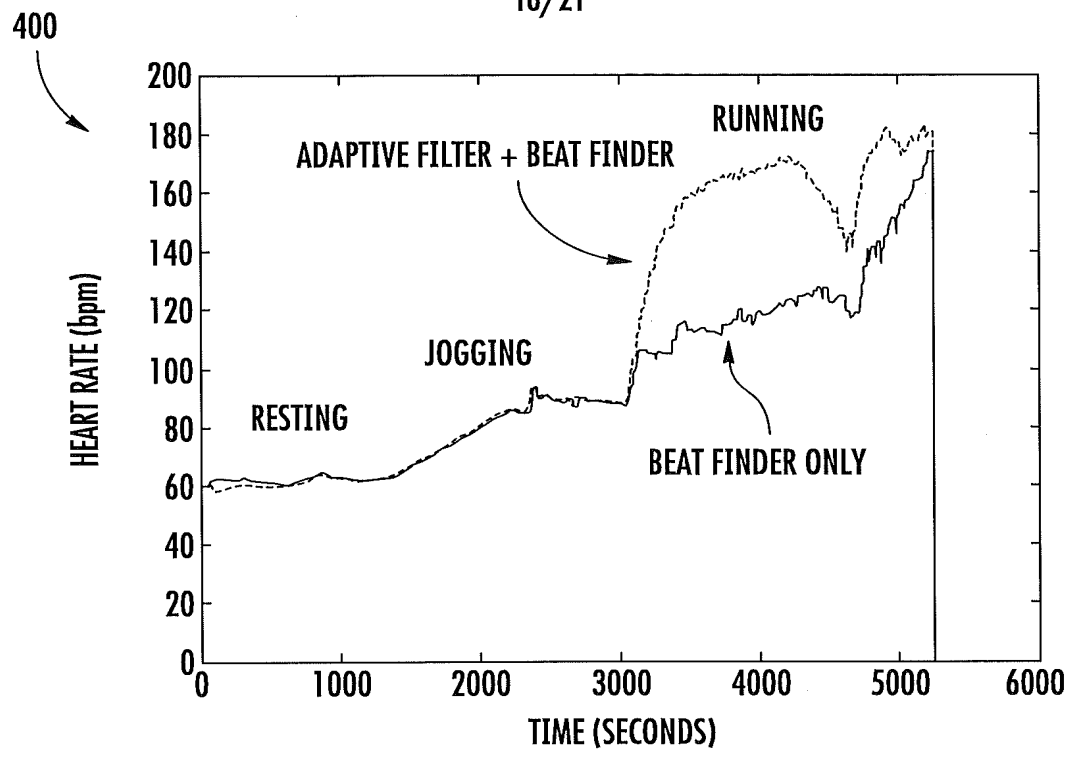

FIG. 15

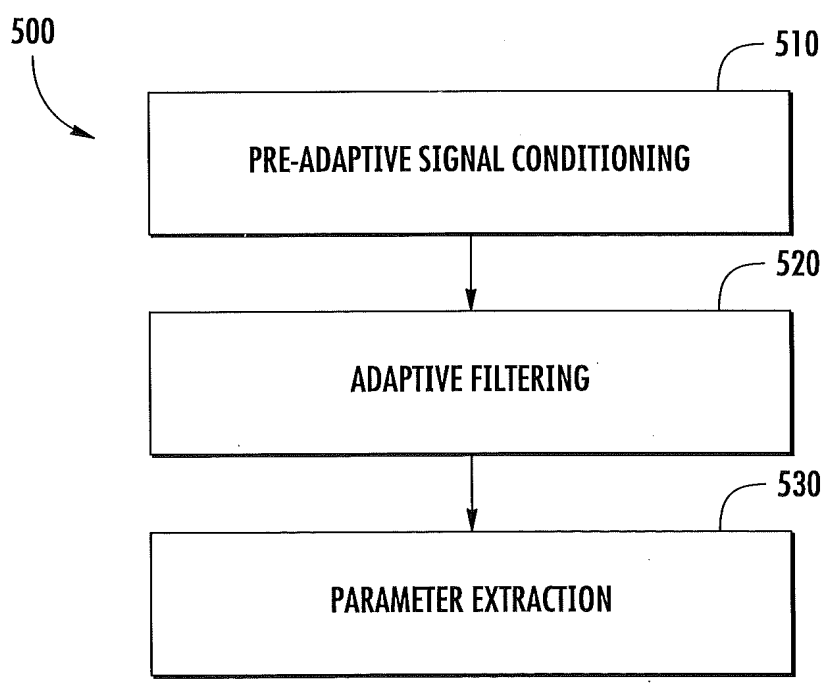

FIG. 16

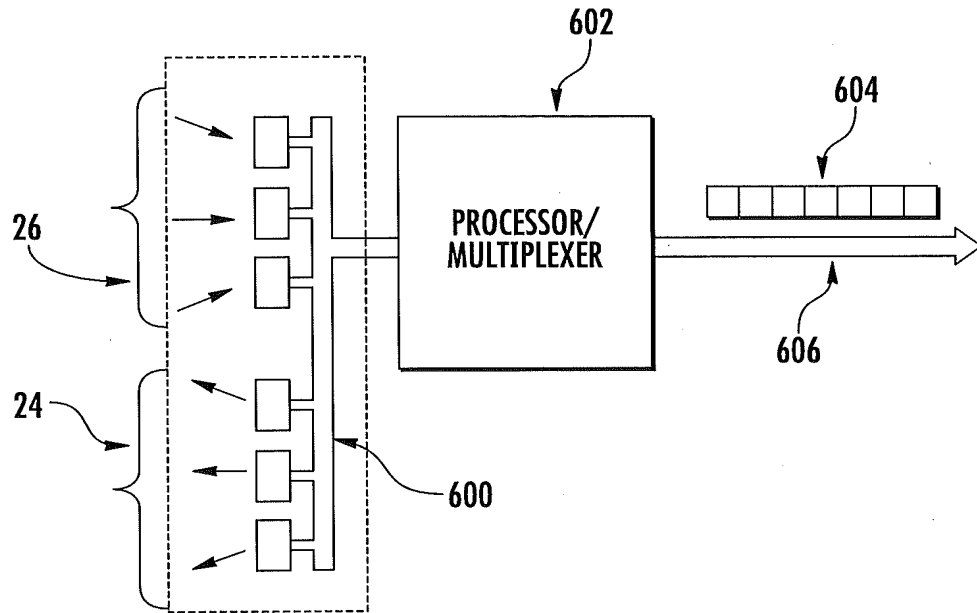

FIG. 17

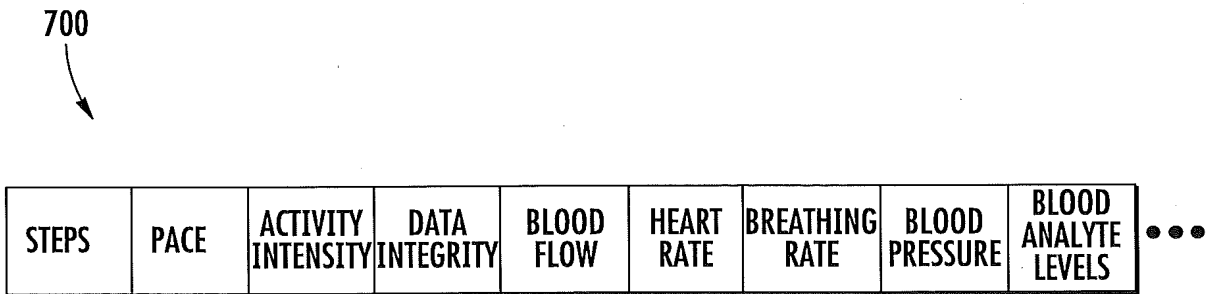

FIG. 18



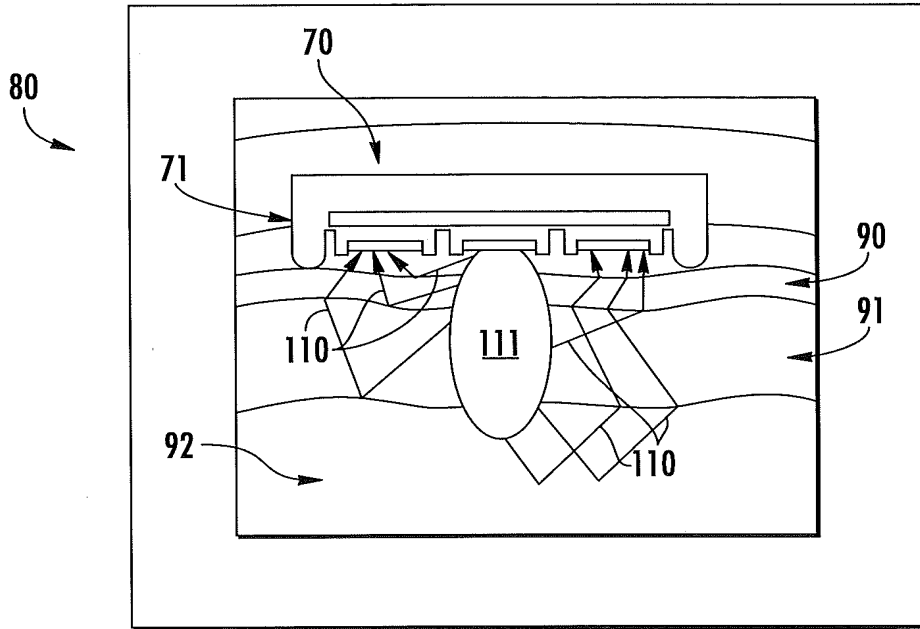

FIG. 19

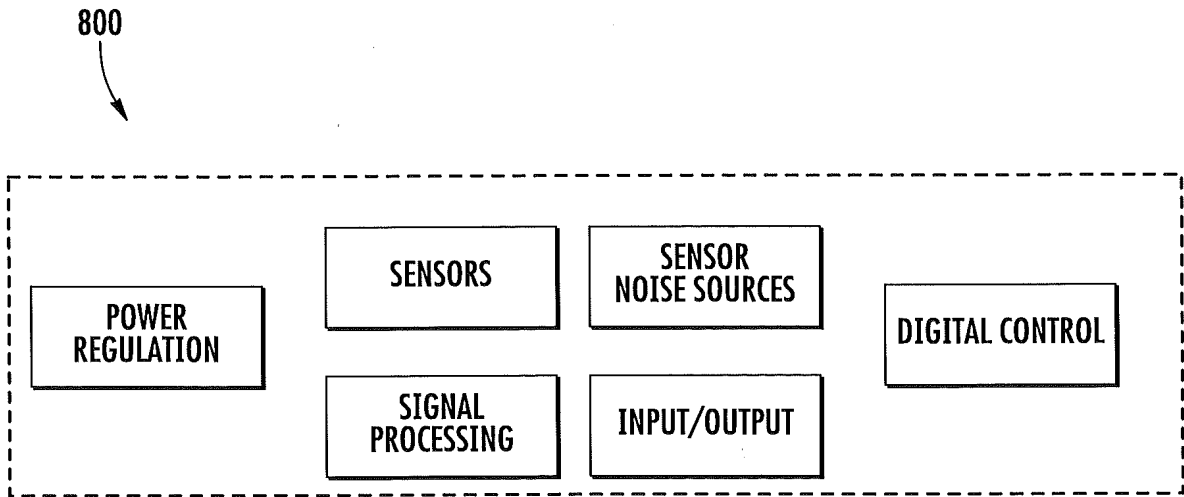

FIG. 20

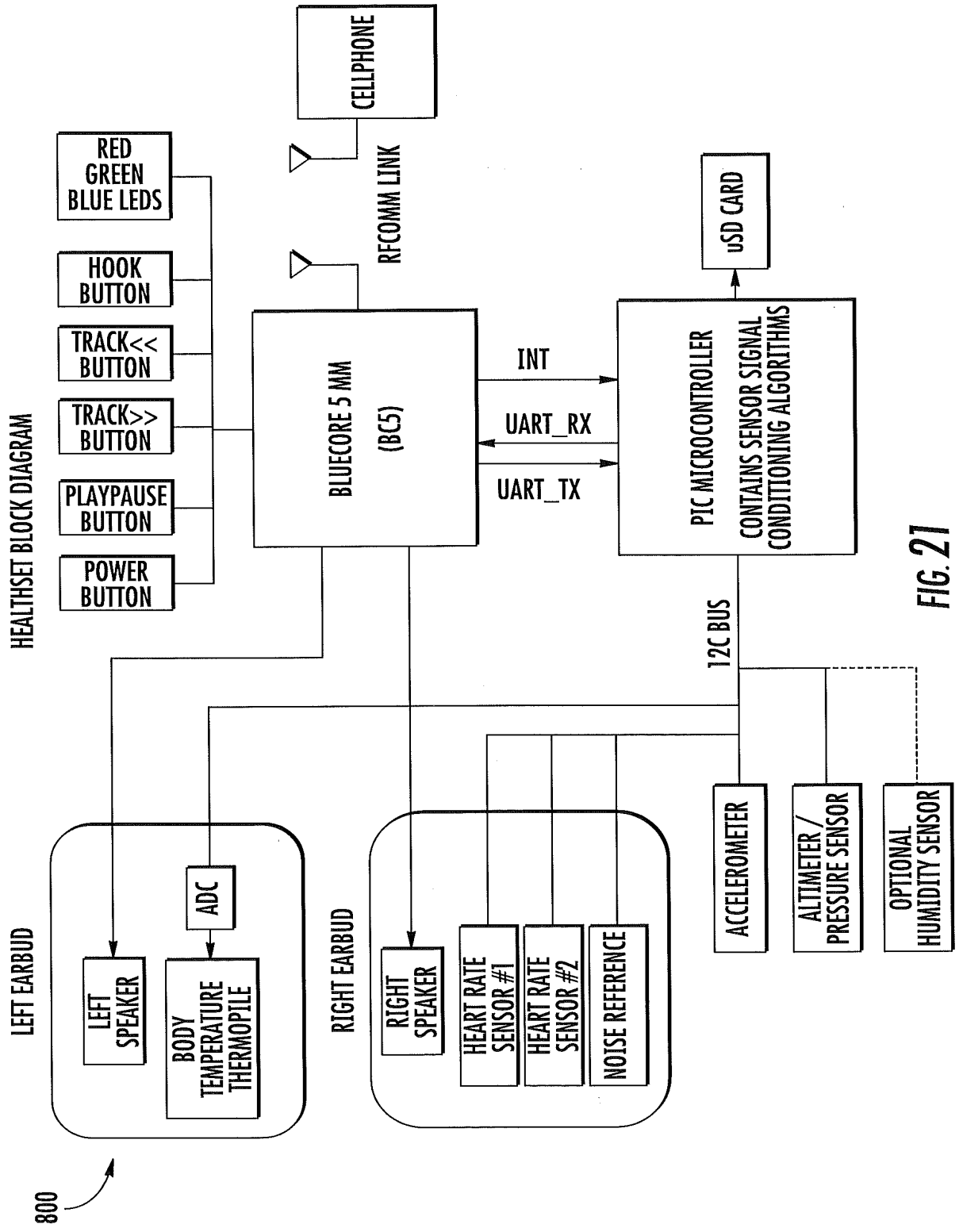

FIG. 21

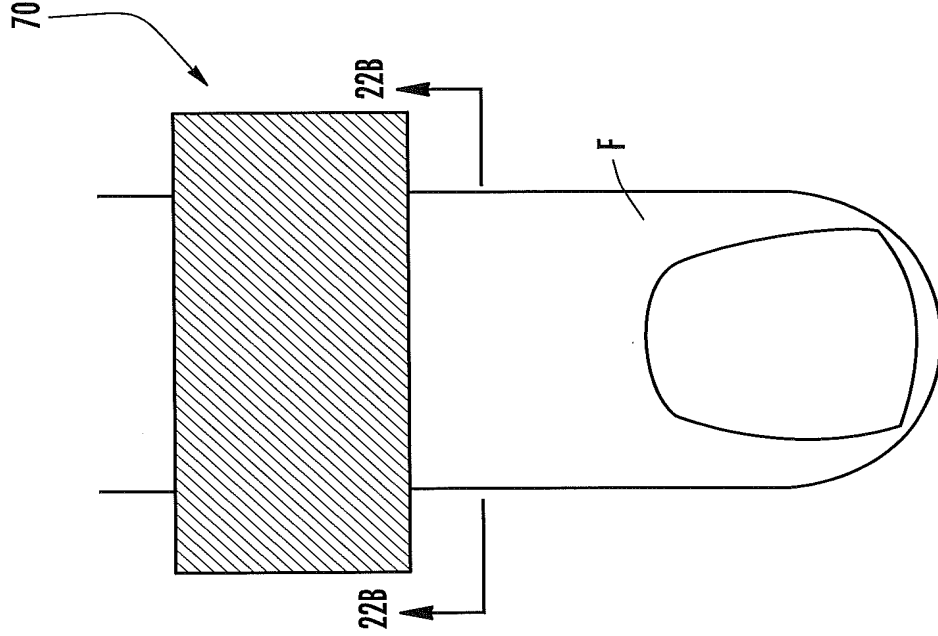

FIG. 22A

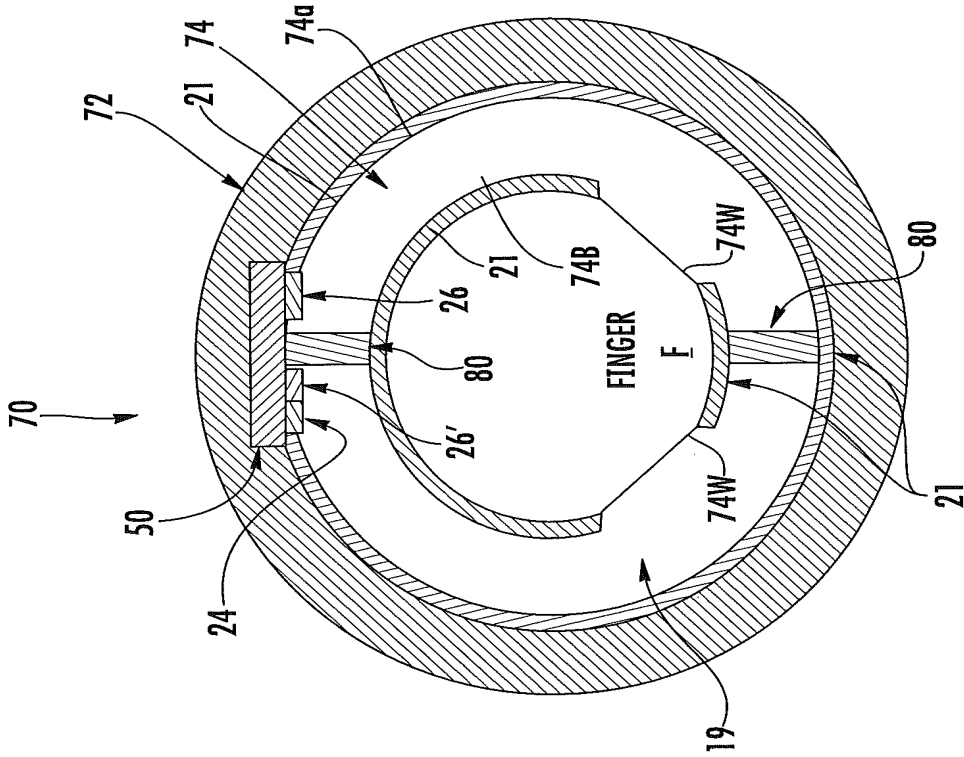

FIG. 22B

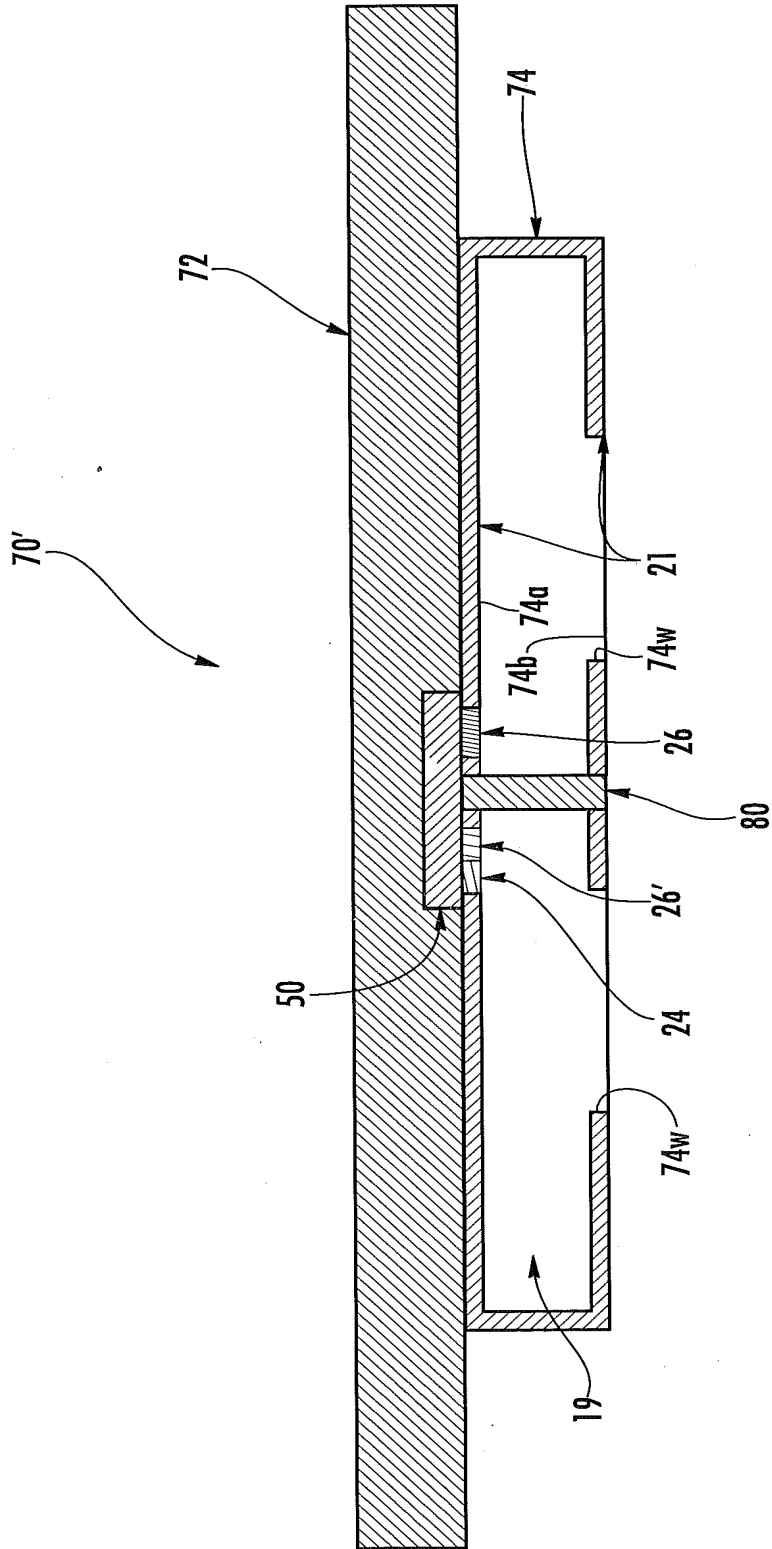

FIG. 23

IN THE UNITED STATES PATENT AND TRADEMARK OFFICE

In re: LeBoeuf et al.

Serial No.: To Be Assigned

Filed: Concurrently Herewith

For: **METHODS AND APPARATUS FOR GENERATING DATA STRINGS CONTAINING  
PHYSIOLOGICAL AND MOTION-RELATED INFORMATION**

Date: February 19, 2014

Commissioner for Patents  
Box 1450  
Alexandria, VA 22313-1450

**INFORMATION DISCLOSURE STATEMENT COVER LETTER**

Sir:

Attached is an Information Disclosure Statement listing of documents previously of record in parent Application No. 12/691,388, filed January 21, 2010. As the benefit of this application is claimed under 35 U.S.C. § 120, no copies need to be furnished in accordance with 37 C.F.R. § 1.98(d); however, copies will be furnished on request.

In accordance with **37 CFR 1.97(b)**, the information disclosure statement is being filed:

- (1) within three months of the filing date of a national application other than a continued prosecution application under §1.53(d);
- (2) within three months of the date of entry of the national stage as set forth in §1.491 in an international application;
- (3) before the mailing of a first Office Action on the merits; or
- (4) before the mailing of a first Office Action after the filing of a request for continued examination under §1.114.

In accordance with **37 CFR 1.97(c)**, the information disclosure statement is being filed after the period specified in 37 CFR 1.97(b) above, but before the mailing date of any of a final action under §1.113, a notice of allowance under §1.311, or an action that otherwise closes prosecution in the application, and is accompanied by one of the following:

(1) The statement specified under **37 CFR 1.97(e)**, as follows:

Each item of information contained in the information disclosure statement was first cited in any communication from a foreign patent office in a counterpart foreign application not more than three months prior to the filing of the information disclosure statement; or

No item of information contained in the information disclosure statement was cited in a communication from a foreign patent office in a counterpart foreign application, and, to the knowledge of the person signing the certification after making reasonable inquiry, no item of information contained in the information disclosure statement was known to any individual designated in §1.56(c) more than three months prior to the filing of the information disclosure statement; or

(2) The fee set forth in §1.17(p);

In accordance with **37 CFR 1.97(d)**, the information disclosure statement is being filed after the period specified in 37 CFR 1.97(c) above, but on or before payment of the issue fee, and is accompanied by **both** of the following:

(1) The statement specified under **37 CFR 1.97(e)**, as follows:

That each item of information contained in the information disclosure statement was first cited in any communication from a foreign patent office in a counterpart foreign application not more than three months prior to the filing of the information disclosure statement; **or**

That no item of information contained in the information disclosure statement was cited in a communication from a foreign patent office in a counterpart foreign application, and, to the knowledge of the person signing the certification after making reasonable inquiry, no item of information contained in the information disclosure statement was known to any individual designated in §1.56(c) more than three months prior to the filing of the information disclosure statement; **and**

(2) The fee set forth in §1.17(p);

In accordance with **37 CFR 1.97(g)**, the information disclosure statement shall not be construed as a representation that a search has been made.

In accordance with **37 CFR 1.97(h)**, the information disclosure statement shall not be construed to be an admission that the information cited in the statement is, or is considered to be, material to patentability as defined in §1.56(b).

The Director is hereby authorized to charge the fee specified in 37 C.F.R. § 1.17(p), and any fee deficiency or credit any overpayment, to Deposit Account No. 50-0220; **or**

No fee is believed due. However, the Director is hereby authorized to charge any deficiency or credit any overpayment to Deposit Account No. 50-0220.

Respectfully submitted,



Needham J. Boddie, II  
Registration No. 40,519  
Attorney for Applicant

**Customer Number 20792**

Myers Bigel Sibley & Sajovec, P.A.  
P.O. Box 37428, Raleigh, NC 27627  
919-854-1400  
919-854-1401 (Fax)

**CERTIFICATION OF TRANSMISSION**

I hereby certify that this correspondence is being transmitted via the Office electronic filing system in accordance with § 1.6(a)(4) to the U.S. Patent and Trademark Office on **February 19, 2014**.

  
Name: Gwen R. Bailey

**INFORMATION DISCLOSURE  
STATEMENT BY APPLICANT**

(use as many sheets as necessary)

Sheet **A1** of **A2**

**Complete if Known**

Application Number	To Be Assigned
Filing Date	Concurrently Herewith
First Named Inventor	Steven Francis LeBeouf
Art Unit	
Examiner Name	
Attorney Docket Number	9653-7TSCT2

**U.S. PATENT DOCUMENTS**

Examiner Initials*	Cite No.	Document Number	Publication Date MM-DD-YYYY	Name of Patentee or Applicant of Cited Document	Pages, Columns, Lines, Where Relevant Passages or Relevant Figures Appear
		Number-Kind Code (if known)			
	1.	US- 2013/0131519	05-2013	LeBoeuf et al.	
	2.	US- 2012/0197093	08-2012	LeBoeuf et al.	
	3.	US- 2011/0105869 A1	05-2011	Wilson et al.	
	4.	US- 2009/0287067 A1	11-2009	Dorogusker et al.	
	5.	US- 2009/0270698 A1	10-2009	Shioi et al.	
	6.	US- 2009/0105556 A1	04-2009	Fricke et al.	
	7.	US- 2009/0054752 A1	02-2009	Jonnalagadda et al.	
	8.	US- 2009/0030350 A1	01-29-2009	Yang et al.	
	9.	US- 2008/0177162 A1	07-2008	Bae et al.	
	10.	US- 2008/0165017 A1	07-2008	Schwartz	
	11.	US- 2008/0096726 A1	04-2008	Riley et al.	
	12.	US- 2008/0076972 A1	03-2008	Dorogusker et al.	
	13.	US- 2006/0009685	01-12-2006	Finarov et al.	
	14.	US- 2005/0228299	10-13-2005	Banet	
	15.	US- 2005/0209516	09-22-2005	Fraden	
	16.	US- 2005/0177034 A1	08-2005	Beaumont	
	17.	US- 8,512,242 B2	08-2013	LeBoeuf et al.	
	18.	US- 8,251,903 B2	08-2012	LeBoeuf et al.	
	19.	US- 8,055,319 B2	11-2011	Oh et al.	
	20.	US- 7,209,775 B2	04-2007	Bae et al.	
	21.	US- 6,859,658 B1	02-2005	Krug	
	22.	US- 6,808,473 B2	10-2004	Hisano et al.	
	23.	US- 6,371,925 B1	04-2002	Imai et al.	
	24.	US- 6,783,501 B2	08-31-2001	Takahashi et al.	
	25.	US- 6,080,110 A	06-2000	Thorgersen	
	26.	US- 6,078,829 A	06-2000	Uchida et al.	

**FOREIGN PATENT DOCUMENTS**

Examiner Initials*	Cite No.	Foreign Patent Document	Publication Date MM-DD-YYYY	Name of Patentee or Applicant of Cited Document	Pages, Columns, Lines, Where Relevant Passages or Relevant Figures Appear	T
		Country Code, Number, Kind Code (if known)				
	27	WO 2013/038296 A1	03-21-2013	KONINKLIJKE PHILIPS ELECTRONICS N.V.		
	28	JP 2007-185348	07-26-2007	OLYMPUS CORP		
	29	JP 2001-025462	01-30-2001	DENSO CORP		

Examiner Signature		Date Considered	
--------------------	--	-----------------	--

\*EXAMINER: Initial if reference considered, whether or not citation is in conformance with MPEP 609. Draw line through citation if not in conformance and not considered. Include copy of this form with next communication to applicant.

<b>INFORMATION DISCLOSURE STATEMENT BY APPLICANT</b>  <i>(use as many sheets as necessary)</i>				<b>Complete if Known</b>			
				Application Number		To Be Assigned	
				Filing Date		Concurrently Herewith	
				First Named Inventor		Steven Francis LeBeouf	
				Art Unit			
				Examiner Name			
Sheet	<b>A2</b>	of	<b>A2</b>	Attorney Docket Number	9653-7TSCT2		

	30	JP 2000-116611	04-25-2000	KOWA SPINNING CO LTD; KOWA CO		
	31	JP 9-299342	11-25-1997	IKYO KK		
	32	JP 9-253062	09-30-1997	IKYO KK		
	33	JP 7-241279	09-19-1995	NIPPON KODEN CORP		

NON PATENT LITERATURE DOCUMENTS			
Examiner Initials*	Cite No.	Include name of the author (in CAPITAL LETTERS), title of the article (when appropriate), title of the item (book, magazine, journal, serial, symposium, catalog, etc.), date, page(s), volume-issue number(s), publisher, city and/or country where published	T
	34	FITRAINER "The Only Trainer You Need"; <a href="http://itami.com">http://itami.com</a> ; Downloaded 2/26/2010; ©2008 FITriainer™; 2 pages	

Examiner Signature		Date Considered	
-----------------------	--	--------------------	--

\*EXAMINER: Initial if reference considered, whether or not citation is in conformance with MPEP 609. Draw line through citation if not in conformance and not considered. Include copy of this form with next communication to applicant.



## TRANSMITTAL FOR POWER OF ATTORNEY TO ONE OR MORE REGISTERED PRACTITIONERS

NOTE: This form is to be submitted with the Power of Attorney by Applicant form (PTO/AIA/82B) to identify the application to which the Power of Attorney is directed, in accordance with 37 CFR 1.5, unless the application number and filing date are identified in the Power of Attorney by Applicant form. If neither form PTO/AIA/82A nor form PTO/AIA/82B identifies the application to which the Power of Attorney is directed, the Power of Attorney will not be recognized in the application.

Application Number	To Be Assigned
Filing Date	Concurrently Herewith
First Named Inventor	Steven Francis LeBoeuf
Title	METHODS AND APPARATUS FOR GENERATING DATA STRINGS CONTAINING PHYSIOLOGICAL AND MOTION-RELATED INFORMATION
Art Unit	
Examiner Name	
Attorney Docket Number	9653-7TSCT2

### SIGNATURE of Applicant or Patent Practitioner

Signature		Date (Optional)	February 19, 2014
Name	Needham J. Boddie, II	Registration Number	40,519
Title (if Applicant is a juristic entity)	Attorney		

Applicant Name (if Applicant is a juristic entity)

**NOTE:** This form must be signed in accordance with 37 CFR 1.33. See 37 CFR 1.4(d) for signature requirements and certifications. If more than one applicant, use multiple forms.

\*Total of 1 forms are submitted.

This collection of information is required by 37 CFR 1.131, 1.32, and 1.33. The information is required to obtain or retain a benefit by the public which is to file (and by the USPTO to process) an application. Confidentiality is governed by 35 U.S.C. 122 and 37 CFR 1.11 and 1.14. This collection is estimated to take 3 minutes to complete, including gathering, preparing, and submitting the completed application form to the USPTO. Time will vary depending upon the individual case. Any comments on the amount of time you require to complete this form and/or suggestions for reducing this burden, should be sent to the Chief Information Officer, U.S. Patent and Trademark Office, U.S. Department of Commerce, P.O. Box 1450, Alexandria, VA 22313-1450. DO NOT SEND FEES OR COMPLETED FORMS TO THIS ADDRESS. SEND TO: Commissioner for Patents, P.O. Box 1450, Alexandria, VA 22313-1450.

If you need assistance in completing the form, call 1-800-PTO-9199 and select option 2.

Under the Paperwork Reduction Act of 1995, no persons are required to respond to a collection of information unless it displays a valid OMB control number

## POWER OF ATTORNEY BY APPLICANT

I hereby revoke all previous powers of attorney given in the application identified in either the attached transmittal letter or the boxes below.

Application Number	Filing Date

(Note: The boxes above may be left blank if information is provided on form PTO/AIA/82A.)

- I hereby appoint the Patent Practitioner(s) associated with the following Customer Number as my/our attorney(s) or agent(s), and to transact all business in the United States Patent and Trademark Office connected therewith for the application referenced in the attached transmittal letter (form PTO/AIA/82A) or identified above: 20792
- OR
- I hereby appoint Practitioner(s) named in the attached list (form PTO/AIA/82C) as my/our attorney(s) or agent(s), and to transact all business in the United States Patent and Trademark Office connected therewith for the patent application referenced in the attached transmittal letter (form PTO/AIA/82A) or identified above. (Note: Complete form PTO/AIA/82C.)

**Please recognize or change the correspondence address for the application identified in the attached transmittal letter or the boxes above to:**

- The address associated with the above-mentioned Customer Number
- OR
- The address associated with Customer Number:
- OR

Firm or Individual Name				
Address				
City	State	Zip		
Country				
Telephone	Email			

I am the Applicant (if the Applicant is a juristic entity, list the Applicant name in the box):

Valencell, Inc.

- Inventor or Joint Inventor (title not required below)
- Legal Representative of a Deceased or Legally Incapacitated Inventor (title not required below)
- Assignee or Person to Whom the Inventor is Under an Obligation to Assign (provide signer's title if applicant is a juristic entity)
- Person Who Otherwise Shows Sufficient Proprietary Interest (e.g., a petition under 37 CFR 1.46(b)(2) was granted in the application or is concurrently being filed with this document) (provide signer's title if applicant is a juristic entity)

**SIGNATURE of Applicant for Patent**

The undersigned (whose title is supplied below) is authorized to act on behalf of the applicant (e.g., where the applicant is a juristic entity).

Signature		Date (Optional)		January 24, 2014
Name	Todd Ackman			
Title	Vice President of Finance, Valencell, Inc.			

**NOTE:** Signature - This form must be signed by the applicant in accordance with 37 CFR 1.33. See 37 CFR 1.4 for signature requirements and certifications. If more than one applicant, use multiple forms.

Total of 1 forms are submitted.

This collection of information is required by 37 CFR 1.131, 1.32, and 1.33. The information is required to obtain or retain a benefit by the public which is to file (and by the USPTO to process) an application. Confidentiality is governed by 35 U.S.C. 122 and 37 CFR 1.11 and 1.14. This collection is estimated to take 3 minutes to complete, including gathering, preparing, and submitting the completed application form to the USPTO. Time will vary depending upon the individual case. Any comments on the amount of time you require to complete this form and/or suggestions for reducing this burden, should be sent to the Chief Information Officer, U.S. Patent and Trademark Office, U.S. Department of Commerce, P.O. Box 1450, Alexandria, VA 22313-1450. DO NOT SEND FEES OR COMPLETED FORMS TO THIS ADDRESS. SEND TO: Commissioner for Patents, P.O. Box 1450, Alexandria, VA 22313-1450.

*If you need assistance in completing the form, call 1-800-PTO-9199 and select option 2.*

## Electronic Patent Application Fee Transmittal

<b>Application Number:</b>				
<b>Filing Date:</b>				
<b>Title of Invention:</b>	METHODS AND APPARATUS FOR GENERATING DATA STRINGS CONTAINING PHYSIOLOGICAL AND MOTION-RELATED INFORMATION			
<b>First Named Inventor/Applicant Name:</b>	Steven Francis LeBoeuf			
<b>Filer:</b>	Needham J. Boddie/Gwen Bailey			
<b>Attorney Docket Number:</b>	9653-7TSCT2			
Filed as Large Entity				
<b>Utility under 35 USC 111(a) Filing Fees</b>				
<b>Description</b>	<b>Fee Code</b>	<b>Quantity</b>	<b>Amount</b>	<b>Sub-Total in USD(\$)</b>
<b>Basic Filing:</b>				
Utility application filing	1011	1	280	280
Utility Search Fee	1111	1	600	600
Utility Examination Fee	1311	1	720	720
<b>Pages:</b>				
<b>Claims:</b>				
Claims in Excess of 20	1202	4	80	320
<b>Miscellaneous-Filing:</b>				
<b>Petition:</b>				

Description	Fee Code	Quantity	Amount	Sub-Total in USD(\$)
<b>Patent-Appeals-and-Interference:</b>				
<b>Post-Allowance-and-Post-Issuance:</b>				
<b>Extension-of-Time:</b>				
<b>Miscellaneous:</b>				
			<b>Total in USD (\$)</b>	<b>1920</b>

## Electronic Acknowledgement Receipt

<b>EFS ID:</b>	18245308
<b>Application Number:</b>	14184396
<b>International Application Number:</b>	
<b>Confirmation Number:</b>	8272
<b>Title of Invention:</b>	METHODS AND APPARATUS FOR GENERATING DATA STRINGS CONTAINING PHYSIOLOGICAL AND MOTION-RELATED INFORMATION
<b>First Named Inventor/Applicant Name:</b>	Steven Francis LeBoeuf
<b>Customer Number:</b>	20792
<b>Filer:</b>	Needham J. Boddie/Gwen Bailey
<b>Filer Authorized By:</b>	Needham J. Boddie
<b>Attorney Docket Number:</b>	9653-7TSCT2
<b>Receipt Date:</b>	19-FEB-2014
<b>Filing Date:</b>	
<b>Time Stamp:</b>	17:40:23
<b>Application Type:</b>	Utility under 35 USC 111(a)

### Payment information:

Submitted with Payment	yes
Payment Type	Deposit Account
Payment was successfully received in RAM	\$1920
RAM confirmation Number	4440
Deposit Account	500220
Authorized User	

The Director of the USPTO is hereby authorized to charge indicated fees and credit any overpayment as follows:

Charge any Additional Fees required under 37 C.F.R. Section 1.16 (National application filing, search, and examination fees)

Charge any Additional Fees required under 37 C.F.R. Section 1.17 (Patent application and reexamination processing fees)

<b>File Listing:</b>					
<b>Document Number</b>	<b>Document Description</b>	<b>File Name</b>	<b>File Size(Bytes)/ Message Digest</b>	<b>Multi Part /.zip</b>	<b>Pages (if appl.)</b>
1	Transmittal of New Application	9653-7TSCT2_ApplicationTransmittal.pdf	143558 6a448813cb437e1da2da0d0c496d5c4b11c6b707	no	1
<b>Warnings:</b>					
<b>Information:</b>					
2	Application Data Sheet	9653-7TSCT2_ADS.pdf	846067 9cc9de59c3fc87a47b072e98f7361922d4999f41	no	7
<b>Warnings:</b>					
<b>Information:</b>					
This is not an USPTO supplied ADS fillable form					
3		9653-7TSCT2_Application.pdf	6677054 d308e022d2213a3efbf826b84ec9c38b11cd5f349	yes	51
	<b>Multipart Description/PDF files in .zip description</b>				
	<b>Document Description</b>		<b>Start</b>	<b>End</b>	
	Specification		1	46	
	Claims		47	50	
	Abstract		51	51	
<b>Warnings:</b>					
<b>Information:</b>					
4	Drawings-only black and white line drawings	9653-7TSCT2_Drawings.pdf	1307677 4d22bdc6f9672ccf6969c9caebd1836065728a	no	21
<b>Warnings:</b>					
<b>Information:</b>					
5		9653-7TSCT2_IDS.pdf	418995 24763c1649a6889d1f5986828179fc8ac809d74e9	yes	4
	<b>Multipart Description/PDF files in .zip description</b>				
	<b>Document Description</b>		<b>Start</b>	<b>End</b>	
	Transmittal Letter		1	2	
Information Disclosure Statement (IDS) Form (SB08)		3	4		
<b>Warnings:</b>					
<b>Information:</b>					

6	Power of Attorney	9653-7TSCT2_POA.pdf	332748	no	2
			0c42ccd41ac1f2d8e6eff963274825ab58055fe		

**Warnings:**

**Information:**

7	Fee Worksheet (SB06)	fee-info.pdf	37019	no	2
			898e0ef5fe9931ae920ea2c6cb0b37743ee0b3c1		

**Warnings:**

**Information:**

<b>Total Files Size (in bytes):</b>			9763118		
-------------------------------------	--	--	---------	--	--

**This Acknowledgement Receipt evidences receipt on the noted date by the USPTO of the indicated documents, characterized by the applicant, and including page counts, where applicable. It serves as evidence of receipt similar to a Post Card, as described in MPEP 503.**

**New Applications Under 35 U.S.C. 111**

**If a new application is being filed and the application includes the necessary components for a filing date (see 37 CFR 1.53(b)-(d) and MPEP 506), a Filing Receipt (37 CFR 1.54) will be issued in due course and the date shown on this Acknowledgement Receipt will establish the filing date of the application.**

**National Stage of an International Application under 35 U.S.C. 371**

**If a timely submission to enter the national stage of an international application is compliant with the conditions of 35 U.S.C. 371 and other applicable requirements a Form PCT/DO/EO/903 indicating acceptance of the application as a national stage submission under 35 U.S.C. 371 will be issued in addition to the Filing Receipt, in due course.**

**New International Application Filed with the USPTO as a Receiving Office**

**If a new international application is being filed and the international application includes the necessary components for an international filing date (see PCT Article 11 and MPEP 1810), a Notification of the International Application Number and of the International Filing Date (Form PCT/RO/105) will be issued in due course, subject to prescriptions concerning national security, and the date shown on this Acknowledgement Receipt will establish the international filing date of the application.**

Document code: WFEE

United States Patent and Trademark Office  
Sales Receipt for Accounting Date: 03/07/2014

CVORAGHA	SALE	#00000016	Mailroom Dt:	02/19/2014	500220	14184396
		01 FC : 1051		140.00 DA		



Attorney Docket No.: 9653-7TSCT2

**PATENT**

**IN THE UNITED STATES PATENT AND TRADEMARK OFFICE**

In re: LeBoeuf, *et al.*  
Serial No.: 14/184,396  
Filed: February 19, 2014

For: METHODS AND APPARATUS FOR GENERATING DATA STRINGS  
CONTAINING PHYSIOLOGICAL AND MOTION-RELATED INFORMATION

Date: February 21, 2014

Mail Stop Patent Application  
Commissioner for Patents  
P.O. Box 1450  
Alexandria, VA 22313-1450

**PRELIMINARY AMENDMENT**

Please enter the following Preliminary Amendment before examining the present application. Applicants provide the present Amendment pursuant to the rules stated in revised 37 C.F.R. 1.121 that became effective on July 30, 2003.

**In the Specification:**

On page 1, please replace the paragraph beginning at line 10 with the following:

-- FIELD OF THE INVENTION

The present invention relates generally to headsets physiological monitoring and, more particularly, to ~~headset earbuds~~ physiological monitoring methods and apparatus. --

**In the Claims:**

1. (Original) A method of generating a data string containing physiological and motion-related information, the method comprising:
  - sensing physical activity of a subject via at least one motion sensor attached to the subject;
  - sensing physiological information from the subject via at least one photoplethysmography (PPG) sensor attached to the subject; and
  - processing signals from the at least one motion sensor and signals from the at least one PPG sensor into a serial data string of physiological information and motion-related information, wherein a plurality of subject physiological parameters can be extracted from the physiological information, and wherein a plurality of subject physical activity parameters can be extracted from the motion-related information.
  
2. (Original) The method of Claim 1, wherein the plurality of subject physical activity parameters that can be extracted from the motion-related information comprise at least two of the following: exertion, activity level, distance traveled, speed, step count, steps/second, pace, limb motion, poise, performance of an activity, mastication rate, mastication intensity, and mastication volume.
  
3. (Original) The method of Claim 1, wherein the plurality of subject physiological parameters that can be extracted from the physiological information comprise at least two of the following: blood flow, blood pulse volume, heart rate, blood analyte levels, breathing rate or volume, blood oxygen levels, blood pressure,  $VO_{2max}$ , the 1st derivative of at least one blood pulse, and the 2nd derivative of at least one blood pulse.
  
4. (Original) The method of Claim 1, wherein the serial data string is parsed out such that an application-specific interface (API) can utilize the physiological information and motion-related information for an application.

5. (Original) The method of Claim 4, wherein the application is configured to generate statistical relationships between subject physiological parameters and subject physical activity parameters in the physiological information and motion-related information.

6. (Original) The method of Claim 5, wherein the application is configured to generate statistical relationships between subject physiological parameters and subject physical activity parameters via at least one of the following: principal component analysis, multiple linear regression, machine learning, and Bland-Altman plots.

7. (Original) The method of Claim 1, further comprising filtering subject motion noise from the signals from the at least one PPG sensor prior to processing signals from the at least one motion sensor and signals from the at least one PPG sensor into the serial data string.

8. (Original) The method of Claim 7, wherein the subject motion noise comprises subject footstep noise.

9. (Original) The method of Claim 7, wherein filtering subject motion noise from the signals from the at least one PPG sensor comprises at least one of the following: FIR (Finite Impulse Response) filtering, IIR (Infinite Impulse Response) filtering, adaptive filtering, phase filtering, and frequency filtering.

10. (Original) The method of Claim 1, wherein the at least one motion sensor comprises at least one of the following: an optical sensor, an inertial sensor, an electrically conductive sensor, a capacitive sensor, an inductive sensor, an accelerometer, and a blocked channel sensor.

11. (Original) The method of Claim 1, wherein the at least one PPG sensor comprises at least one optical emitter, at least one optical detector, and at least one light guide.

12. (Original) The method of Claim 1, wherein the at least one motion sensor and the at least one PPG sensor are integrated into a wearable device.

13. (Original) The method of Claim 12, wherein the wearable device is configured to be attached to the subject at one or more of the following body locations: an ear, a limb, the nose, and a digit.

14. (Original) The method of Claim 1 wherein the physiological information and/or motion-related information comprises information on data integrity.

15. (Original) A wearable device, comprising:  
a housing; and  
a chipset enclosed within the housing, the chipset comprising at least one PPG sensor, at least one motion sensor, and at least one signal processor;  
wherein the housing comprises at least one window that optically exposes the at least one PPG sensor to a body of a subject wearing the device.

16. (Original) The device of Claim 15, further comprising at least one light guide in optical communication with the at least one PPG sensor and the window.

17. (Original) The device of Claim 15, wherein the wearable device is an earbud.

18. (Original) The device of Claim 15, wherein the wearable device is a headset.

19. (Original) The device of Claim 15, wherein the at least one signal processor is configured to process signals from the at least one motion sensor and signals from the at least one PPG sensor into a serial data string of physiological information and motion-related information, wherein a plurality of subject physiological parameters can be extracted from the physiological information, and wherein a plurality of subject physical activity parameters can be extracted from the motion-related information.

20. (Original) The device of Claim 15,

wherein the plurality of subject physical activity parameters that can be extracted from the motion-related information comprise at least two of the following: exertion, activity level, distance traveled, speed, step count, steps/second, pace, limb motion, poise, performance of an activity, mastication rate, mastication intensity, and mastication volume; and

wherein the plurality of subject physiological parameters that can be extracted from the physiological information comprise at least two of the following: blood flow, blood pulse volume, heart rate, blood analyte levels, breathing rate or volume, blood oxygen levels, blood pressure,  $VO_{2max}$ , the 1st derivative of at least one blood pulse, and the 2nd derivative of at least one blood pulse.

21. (Original) The device of Claim 19, wherein the at least one processor is configured to filter subject motion noise from the signals from the at least one PPG sensor prior to processing signals from the at least one motion sensor and signals from the at least one PPG sensor into the serial data string.

22. (Original) The device of Claim 21, wherein the subject motion noise comprises subject footstep noise.

23. (Original) The device of Claim 21, wherein the at least one processor is configured to filter subject motion noise from the signals from the at least one PPG sensor via at least one of the following: FIR (Finite Impulse Response) filtering, IIR (Infinite Impulse Response) filtering, adaptive filtering, phase filtering, and frequency filtering.

24. (Original) The device of Claim 15, wherein the at least one motion sensor comprises at least one of the following: an optical sensor, an inertial sensor, an electrically conductive sensor, a capacitive sensor, an inductive sensor, an accelerometer, and a blocked channel sensor.

**REMARKS**

Applicants have amended the Field of the Invention section of the application, as indicated above, to more accurately describe the field of the claimed invention. Entry of this Preliminary Amendment, examination of the application, and allowance of the application, including Claims 1-24 are respectfully requested.

Respectfully submitted,

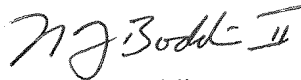

Needham J. Boddie, II  
Attorney for Applicants  
Registration No. 40,519

USPTO Customer No. 20792  
Myers Bigel Sibley & Sajovec, P.A.  
Post Office Box 37428  
Raleigh, North Carolina 27627  
Telephone: (919) 854-1400  
Facsimile: (919) 854-1401  
Doc. No. 1473306

**CERTIFICATION OF TRANSMISSION**

I hereby certify that this correspondence is being transmitted via the Office electronic filing system in accordance with 37 C.F.R. § 1.6(a)(4) to the U.S. Patent and Trademark Office on **February 21, 2014**.

  
\_\_\_\_\_  
Gwen R. Bailey

## Electronic Acknowledgement Receipt

<b>EFS ID:</b>	18268568
<b>Application Number:</b>	14184396
<b>International Application Number:</b>	
<b>Confirmation Number:</b>	8272
<b>Title of Invention:</b>	METHODS AND APPARATUS FOR GENERATING DATA STRINGS CONTAINING PHYSIOLOGICAL AND MOTION-RELATED INFORMATION
<b>First Named Inventor/Applicant Name:</b>	Steven Francis LeBoeuf
<b>Customer Number:</b>	20792
<b>Filer:</b>	Needham J. Boddie/Gwen Bailey
<b>Filer Authorized By:</b>	Needham J. Boddie
<b>Attorney Docket Number:</b>	9653-7TSCT2
<b>Receipt Date:</b>	21-FEB-2014
<b>Filing Date:</b>	
<b>Time Stamp:</b>	15:49:20
<b>Application Type:</b>	Utility under 35 USC 111(a)

### Payment information:

Submitted with Payment	no
------------------------	----

### File Listing:

Document Number	Document Description	File Name	File Size(Bytes)/ Message Digest	Multi Part /.zip	Pages (if appl.)
1		9653-7TSCT2_PreliminaryAmendment.pdf	500732 12bd9a01970535313405d31944737658557e1600	yes	7



<b>Multipart Description/PDF files in .zip description</b>			
<b>Document Description</b>		<b>Start</b>	<b>End</b>
Preliminary Amendment		1	1
Specification		2	2
Claims		3	7

**Warnings:**

**Information:**

<b>Total Files Size (in bytes):</b>	500732
-------------------------------------	--------

**This Acknowledgement Receipt evidences receipt on the noted date by the USPTO of the indicated documents, characterized by the applicant, and including page counts, where applicable. It serves as evidence of receipt similar to a Post Card, as described in MPEP 503.**

**New Applications Under 35 U.S.C. 111**

**If a new application is being filed and the application includes the necessary components for a filing date (see 37 CFR 1.53(b)-(d) and MPEP 506), a Filing Receipt (37 CFR 1.54) will be issued in due course and the date shown on this Acknowledgement Receipt will establish the filing date of the application.**

**National Stage of an International Application under 35 U.S.C. 371**

**If a timely submission to enter the national stage of an international application is compliant with the conditions of 35 U.S.C. 371 and other applicable requirements a Form PCT/DO/EO/903 indicating acceptance of the application as a national stage submission under 35 U.S.C. 371 will be issued in addition to the Filing Receipt, in due course.**

**New International Application Filed with the USPTO as a Receiving Office**

**If a new international application is being filed and the international application includes the necessary components for an international filing date (see PCT Article 11 and MPEP 1810), a Notification of the International Application Number and of the International Filing Date (Form PCT/RO/105) will be issued in due course, subject to prescriptions concerning national security, and the date shown on this Acknowledgement Receipt will establish the international filing date of the application.**





UNITED STATES PATENT AND TRADEMARK OFFICE

UNITED STATES DEPARTMENT OF COMMERCE
United States Patent and Trademark Office
Address: COMMISSIONER FOR PATENTS
P.O. Box 1450
Alexandria, Virginia 22313-1450
www.uspto.gov

Table with 7 columns: APPLICATION NUMBER, FILING or 371(c) DATE, GRP ART UNIT, FIL FEE REC'D, ATTY. DOCKET NO, TOT CLAIMS, IND CLAIMS. Row 1: 14/184,396, 02/19/2014, 3777, 2060, 9653-7TSCT2, 24, 2

CONFIRMATION NO. 8272

20792
MYERS BIGEL SIBLEY & SAJOVEC
PO BOX 37428
RALEIGH, NC 27627

FILING RECEIPT



Date Mailed: 03/07/2014

Receipt is acknowledged of this non-provisional patent application. The application will be taken up for examination in due course. Applicant will be notified as to the results of the examination. Any correspondence concerning the application must include the following identification information: the U.S. APPLICATION NUMBER, FILING DATE, NAME OF APPLICANT, and TITLE OF INVENTION. Fees transmitted by check or draft are subject to collection. Please verify the accuracy of the data presented on this receipt. If an error is noted on this Filing Receipt, please submit a written request for a Filing Receipt Correction. Please provide a copy of this Filing Receipt with the changes noted thereon. If you received a "Notice to File Missing Parts" for this application, please submit any corrections to this Filing Receipt with your reply to the Notice. When the USPTO processes the reply to the Notice, the USPTO will generate another Filing Receipt incorporating the requested corrections

Inventor(s)

Steven Francis LeBoeuf, Raleigh, NC;
Jesse Berkley Tucker, Knightdale, NC;
Michael Edward Aumer, Raleigh, NC;

Applicant(s)

Valencell, Inc., Raleigh, NC

Assignment For Published Patent Application

Valencell, Inc., Raleigh, NC

Power of Attorney: The patent practitioners associated with Customer Number 20792

Domestic Priority data as claimed by applicant

This application is a CON of 12/691,388 01/21/2010
which claims benefit of 61/208,567 02/25/2009
and claims benefit of 61/208,574 02/25/2009
and claims benefit of 61/212,444 04/13/2009
and claims benefit of 61/274,191 08/14/2009

Foreign Applications for which priority is claimed (You may be eligible to benefit from the Patent Prosecution Highway program at the USPTO. Please see http://www.uspto.gov for more information.) - None.

Foreign application information must be provided in an Application Data Sheet in order to constitute a claim to foreign priority. See 37 CFR 1.55 and 1.76.

Permission to Access - A proper Authorization to Permit Access to Application by Participating Offices (PTO/SB/39 or its equivalent) has been received by the USPTO.

**If Required, Foreign Filing License Granted:** 03/07/2014

The country code and number of your priority application, to be used for filing abroad under the Paris Convention, is **US 14/184,396**

**Projected Publication Date:** 06/19/2014

**Non-Publication Request:** No

**Early Publication Request:** No

**Title**

METHODS AND APPARATUS FOR GENERATING DATA STRINGS CONTAINING  
PHYSIOLOGICAL AND MOTION-RELATED INFORMATION

**Preliminary Class**

600

**Statement under 37 CFR 1.55 or 1.78 for AIA (First Inventor to File) Transition Applications:** No

### **PROTECTING YOUR INVENTION OUTSIDE THE UNITED STATES**

Since the rights granted by a U.S. patent extend only throughout the territory of the United States and have no effect in a foreign country, an inventor who wishes patent protection in another country must apply for a patent in a specific country or in regional patent offices. Applicants may wish to consider the filing of an international application under the Patent Cooperation Treaty (PCT). An international (PCT) application generally has the same effect as a regular national patent application in each PCT-member country. The PCT process **simplifies** the filing of patent applications on the same invention in member countries, but **does not result** in a grant of "an international patent" and does not eliminate the need of applicants to file additional documents and fees in countries where patent protection is desired.

Almost every country has its own patent law, and a person desiring a patent in a particular country must make an application for patent in that country in accordance with its particular laws. Since the laws of many countries differ in various respects from the patent law of the United States, applicants are advised to seek guidance from specific foreign countries to ensure that patent rights are not lost prematurely.

Applicants also are advised that in the case of inventions made in the United States, the Director of the USPTO must issue a license before applicants can apply for a patent in a foreign country. The filing of a U.S. patent application serves as a request for a foreign filing license. The application's filing receipt contains further information and guidance as to the status of applicant's license for foreign filing.

Applicants may wish to consult the USPTO booklet, "General Information Concerning Patents" (specifically, the section entitled "Treaties and Foreign Patents") for more information on timeframes and deadlines for filing foreign patent applications. The guide is available either by contacting the USPTO Contact Center at 800-786-9199, or it can be viewed on the USPTO website at <http://www.uspto.gov/web/offices/pac/doc/general/index.html>.

For information on preventing theft of your intellectual property (patents, trademarks and copyrights), you may wish to consult the U.S. Government website, <http://www.stopfakes.gov>. Part of a Department of Commerce initiative, this website includes self-help "toolkits" giving innovators guidance on how to protect intellectual property in specific countries such as China, Korea and Mexico. For questions regarding patent enforcement issues, applicants may call the U.S. Government hotline at 1-866-999-HALT (1-866-999-4258).

**LICENSE FOR FOREIGN FILING UNDER**  
**Title 35, United States Code, Section 184**  
**Title 37, Code of Federal Regulations, 5.11 & 5.15**

**GRANTED**

The applicant has been granted a license under 35 U.S.C. 184, if the phrase "IF REQUIRED, FOREIGN FILING LICENSE GRANTED" followed by a date appears on this form. Such licenses are issued in all applications where the conditions for issuance of a license have been met, regardless of whether or not a license may be required as set forth in 37 CFR 5.15. The scope and limitations of this license are set forth in 37 CFR 5.15(a) unless an earlier license has been issued under 37 CFR 5.15(b). The license is subject to revocation upon written notification. The date indicated is the effective date of the license, unless an earlier license of similar scope has been granted under 37 CFR 5.13 or 5.14.

This license is to be retained by the licensee and may be used at any time on or after the effective date thereof unless it is revoked. This license is automatically transferred to any related applications(s) filed under 37 CFR 1.53(d). This license is not retroactive.

The grant of a license does not in any way lessen the responsibility of a licensee for the security of the subject matter as imposed by any Government contract or the provisions of existing laws relating to espionage and the national security or the export of technical data. Licensees should apprise themselves of current regulations especially with respect to certain countries, of other agencies, particularly the Office of Defense Trade Controls, Department of State (with respect to Arms, Munitions and Implements of War (22 CFR 121-128)); the Bureau of Industry and Security, Department of Commerce (15 CFR parts 730-774); the Office of Foreign Assets Control, Department of Treasury (31 CFR Parts 500+) and the Department of Energy.

**NOT GRANTED**

No license under 35 U.S.C. 184 has been granted at this time, if the phrase "IF REQUIRED, FOREIGN FILING LICENSE GRANTED" DOES NOT appear on this form. Applicant may still petition for a license under 37 CFR 5.12, if a license is desired before the expiration of 6 months from the filing date of the application. If 6 months has lapsed from the filing date of this application and the licensee has not received any indication of a secrecy order under 35 U.S.C. 181, the licensee may foreign file the application pursuant to 37 CFR 5.15(b).

---

***SelectUSA***

The United States represents the largest, most dynamic marketplace in the world and is an unparalleled location for business investment, innovation, and commercialization of new technologies. The U.S. offers tremendous resources and advantages for those who invest and manufacture goods here. Through SelectUSA, our nation works to promote and facilitate business investment. SelectUSA provides information assistance to the international investor community; serves as an ombudsman for existing and potential investors; advocates on behalf of U.S. cities, states, and regions competing for global investment; and counsels U.S. economic development organizations on investment attraction best practices. To learn more about why the United States is the best country in the world to develop technology, manufacture products, deliver services, and grow your business, visit <http://www.SelectUSA.gov> or call +1-202-482-6800.



UNITED STATES PATENT AND TRADEMARK OFFICE

UNITED STATES DEPARTMENT OF COMMERCE  
United States Patent and Trademark Office  
Address: COMMISSIONER FOR PATENTS  
P.O. Box 1450  
Alexandria, Virginia 22313-1450  
www.uspto.gov

APPLICATION NUMBER	FILING OR 371(C) DATE	FIRST NAMED APPLICANT	ATTY. DOCKET NO./TITLE
14/184,396	02/19/2014	Steven Francis LeBoeuf	9653-7TSCT2

**CONFIRMATION NO. 8272**

20792  
MYERS BIGEL SIBLEY & SAJOVEC  
PO BOX 37428  
RALEIGH, NC 27627

**NOTICE**



Date Mailed: 03/07/2014

**INFORMATIONAL NOTICE TO APPLICANT**

Applicant is notified that the above-identified application contains the deficiencies noted below. No period for reply is set forth in this notice for correction of these deficiencies. However, if a deficiency relates to the inventor's oath or declaration, the applicant must file an oath or declaration in compliance with 37 CFR 1.63, or a substitute statement in compliance with 37 CFR 1.64, executed by or with respect to each actual inventor no later than the expiration of the time period set in the "Notice of Allowability" to avoid abandonment. See 37 CFR 1.53(f).

The item(s) indicated below are also required and should be submitted with any reply to this notice to avoid further processing delays.

- A properly executed inventor's oath or declaration has not been received for the following inventor(s):  
Steven Francis LeBoeuf  
Jesse Berkley Tucker  
Michael Edward Aumer



UNITED STATES PATENT AND TRADEMARK OFFICE

UNITED STATES DEPARTMENT OF COMMERCE  
United States Patent and Trademark Office  
Address: COMMISSIONER FOR PATENTS  
P.O. Box 1450  
Alexandria, Virginia 22313-1450  
www.uspto.gov

APPLICATION NUMBER	FILING OR 371(C) DATE	FIRST NAMED APPLICANT	ATTY. DOCKET NO./TITLE
14/184,396	02/19/2014	Steven Francis LeBoeuf	9653-7TSCT2

**CONFIRMATION NO. 8272**

**POA ACCEPTANCE LETTER**

20792  
MYERS BIGEL SIBLEY & SAJOVEC  
PO BOX 37428  
RALEIGH, NC 27627



Date Mailed: 03/07/2014

**NOTICE OF ACCEPTANCE OF POWER OF ATTORNEY**

This is in response to the Power of Attorney filed 02/19/2014.

The Power of Attorney in this application is accepted. Correspondence in this application will be mailed to the above address as provided by 37 CFR 1.33.

/dpham/

Office of Data Management, Application Assistance Unit (571) 272-4000, or (571) 272-4200, or 1-888-786-0101

<b>INFORMATION DISCLOSURE STATEMENT BY APPLICANT</b>  <i>(use as many sheets as necessary)</i>				<b>Complete if Known</b>		
				Application Number	14/184,396	
				Filing Date	February 19, 2014	
				First Named Inventor	Steven Francis LeBoeuf	
				Art Unit	3777	
				Examiner Name		
Sheet	<b>B1</b>	of	<b>B1</b>	Attorney Docket Number	9653-7TSCT2	

U.S. PATENT DOCUMENTS						
Examiner Initials*	Cite No.	Document Number		Publication Date MM-DD-YYYY	Name of Patentee or Applicant of Cited Document	Pages, Columns, Lines, Where Relevant Passages or Relevant Figures Appear
		Number-Kind Code (if known)				
	1.	US-	2010/0217103 A1	08-26-2010	Abdul-Hafiz et al.	
	2.	US-	2004/0054291 A1	03-18-2004	Schultz et al.	
	3.	US-	2004/0034293 A1	02-19-2004	Kimball	

FOREIGN PATENT DOCUMENTS							
Examiner Initials*	Cite No.	Foreign Patent Document		Publication Date MM-DD-YYYY	Name of Patentee or Applicant of Cited Document	Pages, Columns, Lines, Where Relevant Passages or Relevant Figures Appear	T
		Country Code, Number, Kind Code (if known)					

NON PATENT LITERATURE DOCUMENTS				
Examiner Initials*	Cite No.	Include name of the author (in CAPITAL LETTERS), title of the article (when appropriate), title of the item (book, magazine, journal, serial, symposium, catalog, etc.), date, page(s), volume-issue number(s), publisher, city and/or country where published		T
	4.	Notification of Transmittal of The International Search Report and The Written Opinion of the International Searching Authority, or the Declaration corresponding to International Application No. PCT/US2013/070271; Date of Mailing: February 26, 2014; International Search Report; Written Opinion of the International Searching Authority; 13 pages		

Examiner Signature		Date Considered	
--------------------	--	-----------------	--

\*EXAMINER: Initial if reference considered, whether or not citation is in conformance with MPEP 609. Draw line through citation if not in conformance and not considered. Include copy of this form with next communication to applicant.



PATENT COOPERATION TREATY

03-04-14 14:03 RCVD

From the INTERNATIONAL SEARCHING AUTHORITY

PCT COPY

To:  
 MYERS BIGEL SIBLEY & SAJOVEC, P.A.  
 P.O. BOX 37428 RALEIGH NC 27627 USA

NOTIFICATION OF TRANSMITTAL OF  
 THE INTERNATIONAL SEARCH REPORT AND  
 THE WRITTEN OPINION OF THE INTERNATIONAL  
 SEARCHING AUTHORITY, OR THE DECLARATION

(PCT Rule 44.1)

Applicant's or agent's file reference 9653-7IP-WO	Date of mailing (day/month/year) 26 February 2014 (26.02.2014)
International application No. <b>PCT/US2013/070271</b>	International filing date (day/month/year) 15 November 2013 (15.11.2013)
Applicant <b>VALENCELL, INC.</b>	

1.  The applicant is hereby notified that the international search report and the written opinion of the International Searching Authority have been established and are transmitted herewith.

**Filing of amendments and statement under Article 19:**

The applicant is entitled, if he so wishes, to amend the claims of the international application (see Rule 46):

**When?** The time limit for filing such amendments is normally two months from the date of transmittal of the international search report.

**Where?** Directly to the International Bureau of WIPO, 34 chemin des Colombettes  
 1211 Geneva 20, Switzerland, Facsimile No.: +41 22 338 82 70

**For more detailed instructions, see PCT Applicant's Guide, International Phase, paragraphs 9.004 - 9.011.**

2.  The applicant is hereby notified that no international search report will be established and that the declaration under Article 17(2)(a) to that effect and the written opinion of the International Searching Authority are transmitted herewith.
3.  **With regard to any protest** against payment of (an) additional fee(s) under Rule 40.2, the applicant is notified that  
 the protest together with the decision thereon has been transmitted to the International Bureau together with any request to forward the texts of both the protest and the decision thereon to the designated Offices.  
 no decision has been made yet on the protest; the applicant will be notified as soon as a decision is made.

4. Reminders

The applicant may submit comments on an informal basis on the written opinion of the International Searching Authority to the International Bureau. The International Bureau will send a copy of such comments to all designated Offices unless an international preliminary examination report has been or is to be established. Following the expiration of 30 months from the priority date, these comments will also be made available to the public.

Shortly after the expiration of **18 months** from the priority date, the international application will be published by the International Bureau. If the applicant wishes to avoid or postpone publication, a notice of withdrawal of the international application, or of the priority claim, must reach the International Bureau before the completion of the technical preparations for international publication (Rules 90bis.1 and 90bis.3).

Within **19 months** from the priority date, but only in respect of some designated Offices, a demand for international preliminary examination must be filed if the applicant wishes to postpone the entry into the national phase **until 30 months** from the priority date (in some Offices even later); otherwise, the applicant must, **within 20 months** from the priority date, perform the prescribed acts for entry into the national phase before those designated Offices.

In respect of other designated Offices, the time limit of **30 months** (or later) will apply even if no demand is filed within 19 months.

For details about the applicable time limits, Office by Office, see [www.wipo.int/pct/en/texts/time\\_limits.html](http://www.wipo.int/pct/en/texts/time_limits.html) and the PCT Applicant's Guide, National Chapters.

DOCKETED	
By	SD
Date	3/4
ROUTE TO:	
	<input type="checkbox"/>
	<input type="checkbox"/>
	<input type="checkbox"/>
	<input type="checkbox"/>

Name and mailing address of the ISA/KR International Application Division Korean Intellectual Property Office 189 Cheongsa-ro, Seo-gu, Daejeon Metropolitan City, 302-701, Republic of Korea Facsimile No. 82-42-472-7140	Authorized officer  COMMISSIONER  Telephone No. 82-42-481-8754
--	--

\* Attention

Copies of the documents cited in the international search report can be searched in the following Korean Intellectual Property Office English website for six months(expire date : **2014.08.27** ) from the date of mailing of the international search report.

<http://www.kipo.go.kr/en/> => PCT Services => PCT Services

ID : PCT international application number

PW : **UPLASY5H**

Inquiries related to PCT International Search Report or Written Opinion prepared by KIPO as an International Searching Authority can be answered not only by KIPO but also through IPKC (Intellectual Property Korea Center), located in Vienna, VA, which functions as a PCT Help Desk for PCT applicants.

Homepage: <http://www.ipkcenter.com>

Email: [ipkc@ipkcenter.com](mailto:ipkc@ipkcenter.com)

## PATENT COOPERATION TREATY

## PCT

## INTERNATIONAL SEARCH REPORT

(PCT Article 18 and Rules 43 and 44)

Applicant's or agent's file reference 9653-7IP-WO	<b>FOR FURTHER ACTION</b> <span style="float: right;">see Form PCT/ISA/220 as well as, where applicable, item 5 below.</span>	
International application No. <b>PCT/US2013/070271</b>	International filing date ( <i>day/month/year</i> ) <b>15 November 2013 (15.11.2013)</b>	(Earliest) Priority Date ( <i>day/month/year</i> ) <b>14 December 2012 (14.12.2012)</b>
Applicant <b>VALENCELL, INC.</b>		

This International search report has been prepared by this International Searching Authority and is transmitted to the applicant according to Article 18. A copy is being transmitted to the International Bureau.

This international search report consists of a total of 3 sheets.

It is also accompanied by a copy of each prior art document cited in this report.

**1. Basis of the report**

a. With regard to the **language**, the international search was carried out on the basis of:

- the international application in the language in which it was filed  
 a translation of the international application into \_\_\_\_\_, which is the language of a translation furnished for the purposes of international search (Rules 12.3(a) and 23.1(b))

b.  This international search report has been established taking into account the **rectification of an obvious mistake** authorized by or notified to this Authority under Rule 91 (Rule 43.6bis(a)).

c.  With regard to any **nucleotide and/or amino acid sequence** disclosed in the international application, see Box No. I.

2.  **Certain claims were found unsearchable** (See Box No. II)

3.  **Unity of invention is lacking** (See Box No. III)

4. With regard to the **title**,

- the text is approved as submitted by the applicant.  
 the text has been established by this Authority to read as follows:

5. With regard to the **abstract**,

- the text is approved as submitted by the applicant.  
 the text has been established, according to Rule 38.2, by this Authority as it appears in Box No. IV. The applicant may, within one month from the date of mailing of this international search report, submit comments to this Authority.

6. With regard to the **drawings**,

- a. the figure of the **drawings** to be published with the abstract is Figure No. 24A  
 as suggested by the applicant.  
 as selected by this Authority, because the applicant failed to suggest a figure.  
 as selected by this Authority, because this figure better characterizes the invention.
- b.  none of the figures is to be published with the abstract.

## INTERNATIONAL SEARCH REPORT

International application No.  
**PCT/US2013/070271****A. CLASSIFICATION OF SUBJECT MATTER****H04R 1/10(2006.01)i**

According to International Patent Classification (IPC) or to both national classification and IPC

**B. FIELDS SEARCHED**Minimum documentation searched (classification system followed by classification symbols)  
H04R 1/10; A61B 5/1455; A61B 5/00Documentation searched other than minimum documentation to the extent that such documents are included in the fields searched  
Korean utility models and applications for utility models  
Japanese utility models and applications for utility modelsElectronic data base consulted during the international search (name of data base and, where practicable, search terms used)  
eKOMPASS(KIPO internal) & Keywords: PPG. emitter, detector, skin, ear, light guide.**C. DOCUMENTS CONSIDERED TO BE RELEVANT**

Category*	Citation of document, with indication, where appropriate, of the relevant passages	Relevant to claim No.
X	US 2005-0209516 A1 (JACOB FRADEN) 22 September 2005 See paragraphs [0056]-[0061]; and figures 7, 10.	1-19, 21-32
Y		20
Y	US 6078829 A (SHINJI UCHIDA et al.) 20 June 2000 See column 5, lines 29-42; and figure 2.	20
A	US 2010-0217103 A1 (YASSIR ABDUL-HAFIZ et al.) 26 August 2010 See claims 1-2; paragraphs [0056]-[0064]; and figures 9A-9B, 16.	1-32
A	US 2004-0034293 A1 (VICTOR E. KIMBALL) 19 February 2004 See claims 1-7; paragraphs [0047]-[0049]; and figures 5B, 8.	1-32
A	US 2004-0054291 A1 (CHRISTIAN SCHULZ et al.) 18 March 2004 See paragraphs [0036]-[0043]; and figures 4-9.	1-32

 Further documents are listed in the continuation of Box C. See patent family annex.

* Special categories of cited documents:	"T" later document published after the international filing date or priority date and not in conflict with the application but cited to understand the principle or theory underlying the invention
"A" document defining the general state of the art which is not considered to be of particular relevance	"X" document of particular relevance; the claimed invention cannot be considered novel or cannot be considered to involve an inventive step when the document is taken alone
"E" earlier application or patent but published on or after the international filing date	"Y" document of particular relevance; the claimed invention cannot be considered to involve an inventive step when the document is combined with one or more other such documents, such combination being obvious to a person skilled in the art
"L" document which may throw doubts on priority claim(s) or which is cited to establish the publication date of another citation or other special reason (as specified)	"&" document member of the same patent family
"O" document referring to an oral disclosure, use, exhibition or other means	
"P" document published prior to the international filing date but later than the priority date claimed	

Date of the actual completion of the international search  
25 February 2014 (25.02.2014)Date of mailing of the international search report  
**26 February 2014 (26.02.2014)**

Name and mailing address of the ISA/KR  
International Application Division  
Korean Intellectual Property Office  
189 Cheongsa-ro, Seo-gu, Daejeon Metropolitan City, 302-701,  
Republic of Korea  
Facsimile No. +82-42-472-7140

Authorized officer  
KIM, Sung Gon  
Telephone No. +82-42-481-8746



**INTERNATIONAL SEARCH REPORT**

Information on patent family members

International application No.  
**PCT/US2013/070271**

Patent document cited in search report	Publication date	Patent family member(s)	Publication date
US 2005-0209516 A1	22/09/2005	None	
US 6078829 A	20/06/2000	None	
US 2010-0217103 A1	26/08/2010	US 8588880 B2 WO 2011-102846 A2	19/11/2013 25/08/2011
US 2004-0034293 A1	19/02/2004	AU 2003-262620 A1 EP 1545308 A1 JP 2005-535408 A US 6879850 B2 WO 2004-016170 A1	03/03/2004 29/06/2005 24/11/2005 12/04/2005 26/02/2004
US 2004-0054291 A1	18/03/2004	US 7341559 B2	11/03/2008

## PATENT COOPERATION TREATY

From the  
INTERNATIONAL SEARCHING AUTHORITY

To:  
MYERS BIGEL SIBLEY & SAJOVEC, P.A.  
  
P.O. BOX 37428 RALEIGH NC 27627 USA

# PCT

WRITTEN OPINION OF THE  
INTERNATIONAL SEARCHING AUTHORITY

(PCT Rule 43bis.1)

Date of mailing  
(day/month/year) 26 February 2014 (26.02.2014)

Applicant's or agent's file reference  
9653-7IP-WO

**FOR FURTHER ACTION**  
See paragraph 2 below

International application No. <b>PCT/US2013/070271</b>	International filing date (day/month/year) <b>15 November 2013 (15.11.2013)</b>	Priority date(day/month/year) 14 December 2012 (14.12.2012)
---	--	--

International Patent Classification (IPC) or both national classification and IPC  
**H04R 1/10(2006.01)i**

Applicant  
**VALENCELL, INC.**



1. This opinion contains indications relating to the following items:

- Box No. I Basis of the opinion
- Box No. II Priority
- Box No. III Non-establishment of opinion with regard to novelty, inventive step and industrial applicability
- Box No. IV Lack of unity of invention
- Box No. V Reasoned statement under Rule 43bis.1(a)(i) with regard to novelty, inventive step and industrial applicability; citations and explanations supporting such statement
- Box No. VI Certain documents cited
- Box No. VII Certain defects in the international application
- Box No. VIII Certain observations on the international application

2. **FURTHER ACTION**

If a demand for international preliminary examination is made, this opinion will be considered to be a written opinion of the International Preliminary Examining Authority ("IPEA") except that this does not apply where the applicant chooses an Authority other than this one to be the IPEA and the chosen IPEA has notified the International Bureau under Rule 66.1bis(b) that written opinions of this International Searching Authority will not be so considered.

If this opinion is, as provided above, considered to be a written opinion of the IPEA, the applicant is invited to submit to the IPEA a written reply together, where appropriate, with amendments, before the expiration of 3 months from the date of mailing of Form PCT/ISA/220 or before the expiration of 22 months from the priority date, whichever expires later.  
For further options, see Form PCT/ISA/220.

 <p>Name and mailing address of the ISA/KR International Application Division Korean Intellectual Property Office 189 Cheongsu-ro, Seo-gu, Daejeon Metropolitan City, 302-701, Republic of Korea Facsimile No. +82-42-472-7140</p>	<p>Date of completion of this opinion</p> <p>25 February 2014 (25.02.2014)</p>	<p>Authorized officer</p> <p>KIM, Sung Gon</p> <p>Telephone No. +82-42-481-8746</p> 
---	--	---

WRITTEN OPINION OF THE  
INTERNATIONAL SEARCHING AUTHORITY

International application No.  
**PCT/US2013/070271**

**Box No. I Basis of this opinion**

1. With regard to the **language**, this opinion has been established on the basis of:
  - the international application in the language in which it was filed
  - a translation of the international application into \_\_\_\_\_ which is the language of a translation furnished for the purposes of international search (Rules 12.3(a) and 23.1(b))
2.  This opinion has been established taking into account the **rectification of an obvious mistake** authorized by or notified to this Authority under Rule 91 (Rule 43*bis*.1(a))
3. With regard to any **nucleotide and/or amino acid sequence** disclosed in the international application, this opinion has been established on the basis of a sequence listing filed or furnished:
  - a. (means)
    - on paper
    - in electronic form
  - b. (time)
    - in the international application as filed.
    - together with the international application in electronic form.
    - subsequently to this Authority for the purposes of search.
4.  In addition, in the case that more than one version or copy of a sequence listing has been filed or furnished, the required statements that the information in the subsequent or additional copies is identical to that in the application as filed or does not go beyond the application as filed, as appropriate, were furnished.
5. Additional comments:

**WRITTEN OPINION OF THE  
INTERNATIONAL SEARCHING AUTHORITY**

International application No.  
**PCT/US2013/070271**

**Box No. V Reasoned statement under Rule 43bis.1(a)(i) with regard to novelty, inventive step or industrial applicability; citations and explanations supporting such statement**

**1. Statement**

Novelty (N)	Claims	1-32	YES
	Claims	NONE	NO
Inventive step (IS)	Claims	NONE	YES
	Claims	1-32	NO
Industrial applicability (IA)	Claims	1-32	YES
	Claims	NONE	NO

**2. Citations and explanations :**

Reference is made to the following documents:

D1: US 2005-0209516 A1 (JACOB FRADEN) 22 September 2005

D2: US 6078829 A (SHINJI UCHIDA et al.) 20 June 2000

**1. Novelty and Inventive Step**

**1.1 Claims [1-15]**

**1.1.1 Independent Claim [1]**

D1, which is considered to be the closest prior art to the subject matter of claim [1], discloses a device for detecting photo-plethysmographic signals from a patient ear canal comprising: an ear plug (64) inserted into an ear canal (4) of ears (60) (see paragraph [0056] and figure 10); and a first LED (71) and light detector (73) (see paragraphs [0057], [0061] and figures 7, 10). Claim [1] differs from D1 in that the at least one light guide is in optical communication with the optical emitter or optical detector, and that the at least one light guide is configured to deliver light from the optical emitter into an ear region of the subject via the distal end or collect light from an ear region of the subject via the distal end and deliver collected light to the optical detector. However, such an additional feature is virtually suggested by the feature of D1 considering that the entire sensing assembly works as follows: a first LED (71) emits light that in the form of a first beam (87) travels through the body of an illuminator (65) which comes in physical contact (120) with the opening of the ear canal and this contact allows light (in the form of a second beam 88) to continue traveling into the biological tissue and be modulated by the oxyhemoglobin and pulsatile blood volume (see paragraph [0061] and figure 10). Accordingly, claim [1] would have been obvious over D1. Therefore, claim [1] lacks an inventive step under PCT Article 33(3).

Continued on Supplemental Box



Supplemental Box

In case the space in any of the preceding boxes is not sufficient.  
Continuation of: Box No. V

1.1.2 Dependent Claims [2-15]

The additional feature of claim [2] dependent on claim 1 is identical to the feature of D1 in that an ear plug (64) is inserted into an ear canal (4) of ears (60) (see paragraph [0056] and figure 10).

The additional features of claims [3, 5-6] dependent on claim 1 relate to the material of the at least one light guide. However, such additional features are merely matters of design option when the general knowledge in the relevant field of the art is used.

The additional feature of claim [4] is considered to be a minor difference over the disclosure of D1 that falls under the general knowledge of a person skilled in the art.

The additional feature of claim [7] dependent on claim 1 is identical to the feature of D1 in that shield 66 may be fabricated of any material that is opaque for the used light (see paragraph [0056]).

The additional feature of claim [8] dependent on claim 1 is identical to the feature of D1 in that after installation of a light transmission assembly (63) onto a holder (76), both LEDs can send light through an illuminator (65) (see paragraph [0058]).

The additional feature of claim [9] dependent on claim 1 is identical to the feature of D1 in that a light transmitting assembly (63) may be plugged into a holder (76) so that a butt (85), which is part of an ear plug (64), comes in proximity with an end (74) of a light coupler (72) (see paragraph [0058]).

The additional feature of claim [10] dependent on claim 1 is virtually suggested by the feature of D1 considering that the shield (66) may be fabricated of any material that is opaque for the used light (see paragraph [0056]).

The additional feature of claim [11] dependent on claim 1 is identical to the feature of D1 in a variant of an ear plug (64) with protruding ribs (84) that are pliable, flexible and resilient (see paragraph [0059] and figure 7).

Continued on The Next Page

**Supplemental Box**

In case the space in any of the preceding boxes is not sufficient.  
Continuation of: Previous Page

The additional feature of claim [12] dependent on claim 1 is identical to the feature of D1 in that first and second LEDs (71 and 77) are coupled to a first section (108), while a detector (73) is coupled to a second section (110) by means of the intermediate light conducting rod (106) (see paragraph [0060]).

The additional feature of claim [13] dependent on claim 1 is merely a variation of the feature of D1 in that the modulated light in the form of a receiving light beam (111) passes toward a detector (73) (see paragraph [0060]), and a person skilled in the art would arrive at the claimed invention by general experimentation alone without exercising any ingenuity.

The additional feature of claim [14] dependent on claim 1 is virtually suggested by the feature of D1 considering that it detects the photo-plethysmographic waves of the pulsatile blood at two wavelengths and passes them to a module 27 for the signal processing (see paragraph [0051]).

The additional feature of claim [15] dependent on claim 1 is identical to the feature of D1 in that the light emitting devices (for example, light emitting diodes-LED) are positioned inside a probe (62) (see paragraph [0056] and figure 6).

Accordingly, claims [2-15] would have been obvious over D1. Therefore, claims [2-15] lack an inventive step under PCT Article 33(3).

**1.2 Claims [16-22]**

**1.2.1. Independent Claim [16]**

D1, which is considered to be the closest prior art to the subject matter of claim [16], discloses a device for detecting photo-plethysmographic signals from a patient ear canal, comprising: an ear plug (64) inserted into an ear canal (4) of ears (60) (see paragraph [0056] and figure 10); and a first LED (71), a second LED (77) and a light detector (73) (see paragraphs [0057], [0061] and figures 7, 10).

Claim [16] differs from D1 in that the first light guide is in optical communication with the optical emitter and is configured to deliver light from the optical emitter into an ear region of the subject via the first light guide distal end, and that the second light guide is in optical

Continued on The Next Page

Supplemental Box

In case the space in any of the preceding boxes is not sufficient.  
Continuation of: Previous Page

communication with the optical detector and is configured to collect light from an ear region of the subject via the second light guide distal end and deliver collected light to the optical detector. However, such additional features are virtually suggested by the feature of D1 considering that the entire sensing assembly works as follows: a first LED (71) emits light that in the form of a first beam (87) travels through the body of an illuminator (65) which comes in physical contact (120) with the opening of the ear canal and this contact allows light (in the form of a second beam 88) to continue traveling into the biological tissue and be modulated by the oxyhemoglobin and pulsatile blood volume (see paragraph [0061] and figure 10). Accordingly, claim [16] would have been obvious over D1. Therefore, claim [16] lacks an inventive step under PCT Article 33(3).

1.2.2 Dependent Claims [17-19, 21-22]

The technical features of claims [17-19, 21-22] are substantially the same as those of claims 2-4, 14-15 respectively. Accordingly, the same reasoning as in claims 2-4, 14-15 applies respectively to claims [17-19, 21-22], and claims [17-19, 21-22] would have been obvious over D1. Therefore, claims [17-19, 21-22] lack an inventive step under PCT Article 33(3).

1.2.3 Dependent Claim [20]

D1 does not disclose that a speaker is disposed within the housing, and that the housing comprises at least one aperture through which sound from the speaker can pass. But D2 discloses that the measuring apparatus for biological information is provided with a speaker (8) as an acoustic oscillator on the side facing the external auditory meatus (see column 5, lines 29-42 and figure 2). Accordingly, claim [20] would have been obvious over D1 in view of D2. Therefore, claim [20] lacks an inventive step under PCT Article 33(3).

1.3 Claims [23-26]

1.3.1 Independent Claim [23]

D1, which is considered to be the closest prior art to the subject matter of claim [23], discloses a device for detecting photo-plethysmographic signals from a patient ear canal,

Continued on The Next Page

**Supplemental Box**

In case the space in any of the preceding boxes is not sufficient.  
Continuation of: Previous Page

comprising: an ear plug (64) inserted into an ear canal (4) of ears (60) (see paragraph [0056] and figure 10); and a first LED (71) and a light detector (73) (see paragraphs [0057], [0061] and figures 7, 10).

Claim [23] differs from D1 in that the light guide is in optical communication with the optical emitter and is configured to deliver light from the optical emitter into an ear region of the subject via the light guide distal end, and that the light guide is in optical communication with the optical detector and is configured to collect light from an ear region of the subject via the light guide distal end and deliver collected light to the optical detector. However, such the features are virtually suggested by the feature of D1 considering that the entire sensing assembly works as follows: a first LED (71) emits light that in form of a first beam (87) travels through the body of an illuminator (65) which comes in physical contact (120) with the opening of the ear canal and this contact allows light (in form of a second beam 88) to continue traveling into the biological tissue and be modulated by the oxyhemoglobin and pulsatile blood volume (see paragraph [0061] and figure 10). Accordingly, claim [23] would have been obvious over D1. Therefore, claim [23] lacks an inventive step under PCT Article 33(3).

**1.3.2 Dependent Claims [24-26]**

The technical features of claims [24-26] are substantially the same as those of claims 15, 2-3 respectively. Accordingly, the same reasoning as in claims 15, 2-3 applies respectively to claims [24-26], and claims [24-26] would have been obvious over D1. Therefore, claims [24-26] lack an inventive step under PCT Article 33(3).

**1.4 Claims [27-32]**

**1.4.1 Independent Claim [27]**

The independent claim [27] relates to a wearable sensor module, but it has the same technical features as those of claim 1 except for the type of invention. Thus, the same reasoning as in claim 1 could be applied to claim [27]. Therefore, claim [27] lacks an inventive step under PCT Article 33(3).

Continued on The Next Page

**Supplemental Box**

In case the space in any of the preceding boxes is not sufficient.  
Continuation of : Previous Page

1.4.2 Dependent Claims [28-32]

The technical features of claims [28-32] are substantially the same as those of claims 2-3, 7, 10, 15 respectively. Accordingly, the same reasoning as in claims 2-3, 7, 10, 15 applies respectively to claims [28-32], and claims [28-32] would have been obvious over D1. Therefore, claims [28-32] lack an inventive step under PCT Article 33(3).

2. Industrial Applicability

Claims [1-32] are industrially applicable under PCT Article 33(4).

## Electronic Acknowledgement Receipt

<b>EFS ID:</b>	18506546
<b>Application Number:</b>	14184396
<b>International Application Number:</b>	
<b>Confirmation Number:</b>	8272
<b>Title of Invention:</b>	METHODS AND APPARATUS FOR GENERATING DATA STRINGS CONTAINING PHYSIOLOGICAL AND MOTION-RELATED INFORMATION
<b>First Named Inventor/Applicant Name:</b>	Steven Francis LeBoeuf
<b>Customer Number:</b>	20792
<b>Filer:</b>	Needham J. Boddie/Gwen Bailey
<b>Filer Authorized By:</b>	Needham J. Boddie
<b>Attorney Docket Number:</b>	9653-7TSCT2
<b>Receipt Date:</b>	18-MAR-2014
<b>Filing Date:</b>	19-FEB-2014
<b>Time Stamp:</b>	13:11:28
<b>Application Type:</b>	Utility under 35 USC 111(a)

### Payment information:

Submitted with Payment	no
------------------------	----

### File Listing:

Document Number	Document Description	File Name	File Size(Bytes)/ Message Digest	Multi Part /.zip	Pages (if appl.)
1		9653-7TSCT2_IDS.pdf	292928 f027d19d97c9a6cd4359605107e415e08b774720	yes	3

Multipart Description/PDF files in .zip description			
	Document Description	Start	End
	Transmittal Letter	1	2
	Information Disclosure Statement (IDS) Form (SB08)	3	3

**Warnings:**

**Information:**

2	Non Patent Literature	ISR_Feb_26_2014.pdf	1217310	no	13
			a401bcbcb0d6212d5458c84004a9ffd91d7d2677		

**Warnings:**

**Information:**

<b>Total Files Size (in bytes):</b>		1510238
-------------------------------------	--	---------

**This Acknowledgement Receipt evidences receipt on the noted date by the USPTO of the indicated documents, characterized by the applicant, and including page counts, where applicable. It serves as evidence of receipt similar to a Post Card, as described in MPEP 503.**

**New Applications Under 35 U.S.C. 111**

**If a new application is being filed and the application includes the necessary components for a filing date (see 37 CFR 1.53(b)-(d) and MPEP 506), a Filing Receipt (37 CFR 1.54) will be issued in due course and the date shown on this Acknowledgement Receipt will establish the filing date of the application.**

**National Stage of an International Application under 35 U.S.C. 371**

**If a timely submission to enter the national stage of an international application is compliant with the conditions of 35 U.S.C. 371 and other applicable requirements a Form PCT/DO/EO/903 indicating acceptance of the application as a national stage submission under 35 U.S.C. 371 will be issued in addition to the Filing Receipt, in due course.**

**New International Application Filed with the USPTO as a Receiving Office**

**If a new international application is being filed and the international application includes the necessary components for an international filing date (see PCT Article 11 and MPEP 1810), a Notification of the International Application Number and of the International Filing Date (Form PCT/RO/105) will be issued in due course, subject to prescriptions concerning national security, and the date shown on this Acknowledgement Receipt will establish the international filing date of the application.**

## IN THE UNITED STATES PATENT AND TRADEMARK OFFICE

In re: LeBoeuf et al.

Confirmation No.: 8272

Serial No.: 14/184,396

Group Art Unit: 3777

Filed: February 19, 2014

For: **METHODS AND APPARATUS FOR GENERATING DATA STRINGS CONTAINING  
PHYSIOLOGICAL AND MOTION-RELATED INFORMATION**

Date: March 18, 2014

Commissioner for Patents  
Box 1450  
Alexandria, VA 22313-1450**INFORMATION DISCLOSURE STATEMENT COVER LETTER**

Sir:

Attached is an Information Disclosure Statement listing of documents, together with a copy of any listed foreign patent document and/or non-patent literature. A copy of any listed U.S. patent and/or U.S. patent application publication is not provided herewith in accordance with 37 C.F.R. § 1.98(a)(2)(ii).

- In accordance with **37 CFR 1.97(b)**, the information disclosure statement is being filed:
- (1) within three months of the filing date of a national application other than a continued prosecution application under §1.53(d);
  - (2) within three months of the date of entry of the national stage as set forth in §1.491 in an international application;
  - (3) before the mailing of a first Office Action on the merits; or
  - (4) before the mailing of a first Office Action after the filing of a request for continued examination under §1.114.

In accordance with **37 CFR 1.97(c)**, the information disclosure statement is being filed after the period specified in 37 CFR 1.97(b) above, but before the mailing date of any of a final action under §1.113, a notice of allowance under §1.311, or an action that otherwise closes prosecution in the application, and is accompanied by one of the following:

- (1) The statement specified under **37 CFR 1.97(e)**, as follows:
  - Each item of information contained in the information disclosure statement was first cited in any communication from a foreign patent office in a counterpart foreign application not more than three months prior to the filing of the information disclosure statement; or
  - No item of information contained in the information disclosure statement was cited in a communication from a foreign patent office in a counterpart foreign application, and, to the knowledge of the person signing the certification after making reasonable inquiry, no item of information contained in the information disclosure statement was known to any individual designated in §1.56(c) more than three months prior to the filing of the information disclosure statement; or

- (2) The fee set forth in §1.17(p);

In accordance with **37 CFR 1.97(d)**, the information disclosure statement is being filed after the period specified in 37 CFR 1.97(c) above, but on or before payment of the issue fee, and is accompanied by both of the following:



(1) The statement specified under **37 CFR 1.97(e)**, as follows:

That each item of information contained in the information disclosure statement was first cited in any communication from a foreign patent office in a counterpart foreign application not more than three months prior to the filing of the information disclosure statement; or

That no item of information contained in the information disclosure statement was cited in a communication from a foreign patent office in a counterpart foreign application, and, to the knowledge of the person signing the certification after making reasonable inquiry, no item of information contained in the information disclosure statement was known to any individual designated in §1.56(c) more than three months prior to the filing of the information disclosure statement; and

(2) The fee set forth in §1.17(p);

In accordance with **37 CFR 1.97(g)**, the information disclosure statement shall not be construed as a representation that a search has been made.

In accordance with **37 CFR 1.97(h)**, the information disclosure statement shall not be construed to be an admission that the information cited in the statement is, or is considered to be, material to patentability as defined in §1.56(b).

The Director is hereby authorized to charge the fee specified in 37 C.F.R. § 1.17(p), and any fee deficiency or credit any overpayment, to Deposit Account No. 50-0220; or

No fee is believed due. However, the Director is hereby authorized to charge any deficiency or credit any overpayment to Deposit Account No. 50-0220.

Respectfully submitted,



Needham J. Boddie, II  
Registration No. 40,519  
Attorney for Applicant

**Customer Number 20792**

Myers Bigel Sibley & Sajovec, P.A.  
P.O. Box 37428, Raleigh, NC 27627  
919-854-1400  
919-854-1401 (Fax)

**CERTIFICATION OF TRANSMISSION**

I hereby certify that this correspondence is being transmitted via the Office electronic filing system in accordance with § 1.6(a)(4) to the U.S. Patent and Trademark Office on **March 18, 2014**.

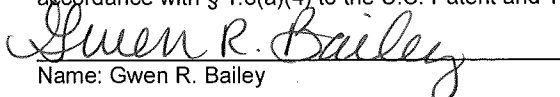
  
Name: Gwen R. Bailey

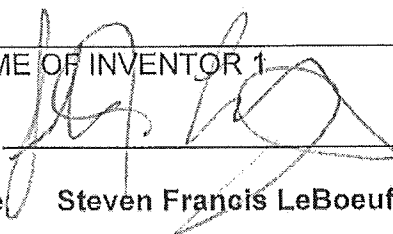
DECLARATION (37 CFR 1.63) FOR UTILITY OR DESIGN APPLICATION USING AN APPLICATION DATA SHEET (37 CFR 1.76)	
Title of Invention	METHODS AND APPARATUS FOR GENERATING DATA STRINGS CONTAINING PHYSIOLOGICAL AND MOTION-RELATED INFORMATION
As a below named inventor, I hereby declare that:  This declaration is directed to: <input type="checkbox"/> The attached application, or <input checked="" type="checkbox"/> United States application or PCT international application number <u>14/184,396</u> filed on <u>February 19, 2014</u> , <input type="checkbox"/> As amended on _____ (if applicable).	
The above-identified application was made or authorized to be made by me.  I believe that I am the original inventor or an original joint inventor of a claimed invention in the application.  I have reviewed and understand the contents of the above-identified specification, including the claims, as amended by any amendment specifically referred to above.  I am aware of the duty to disclose information which is material to patentability as defined in 37 C.F.R. § 1.56, including for continuation-in-part applications, material information that became available between the filing date of the prior application and the national or PCT international filing date of the continuation-in-part application.  I hereby acknowledge that any willful false statement made in this declaration is punishable under 18 U.S.C. 1001 by fine or imprisonment of not more than five (5) years, or both.	
LEGAL NAME OF INVENTOR 1	
Signature: 	Date: <u>3/18/2014</u>
Legal Name: <u>Steven Francis LeBoeuf</u>	

LEGAL NAME OF INVENTOR 2

Signature: *Jesse Berkley Tucker* Date: 3/17/2014

Legal Name: **Jesse Berkley Tucker**

LEGAL NAME OF INVENTOR 3

Signature: *Michael Edward Aumer* Date: 3/18/14

Legal Name: **Michael Edward Aumer**

## Electronic Acknowledgement Receipt

<b>EFS ID:</b>	18555787
<b>Application Number:</b>	14184396
<b>International Application Number:</b>	
<b>Confirmation Number:</b>	8272
<b>Title of Invention:</b>	METHODS AND APPARATUS FOR GENERATING DATA STRINGS CONTAINING PHYSIOLOGICAL AND MOTION-RELATED INFORMATION
<b>First Named Inventor/Applicant Name:</b>	Steven Francis LeBoeuf
<b>Customer Number:</b>	20792
<b>Filer:</b>	Needham J. Boddie/Gwen Bailey
<b>Filer Authorized By:</b>	Needham J. Boddie
<b>Attorney Docket Number:</b>	9653-7TSCT2
<b>Receipt Date:</b>	23-MAR-2014
<b>Filing Date:</b>	19-FEB-2014
<b>Time Stamp:</b>	14:49:05
<b>Application Type:</b>	Utility under 35 USC 111(a)

### Payment information:

Submitted with Payment	no
------------------------	----

### File Listing:

Document Number	Document Description	File Name	File Size(Bytes)/ Message Digest	Multi Part /.zip	Pages (if appl.)
1	Oath or Declaration filed	9653-7TSCT2_Declaration.pdf	165789 <small>cf3e69ba27d6ac5b28d2c56286f85eebff18479e</small>	no	2

### Warnings:

### Information:

**This Acknowledgement Receipt evidences receipt on the noted date by the USPTO of the indicated documents, characterized by the applicant, and including page counts, where applicable. It serves as evidence of receipt similar to a Post Card, as described in MPEP 503.**

**New Applications Under 35 U.S.C. 111**

**If a new application is being filed and the application includes the necessary components for a filing date (see 37 CFR 1.53(b)-(d) and MPEP 506), a Filing Receipt (37 CFR 1.54) will be issued in due course and the date shown on this Acknowledgement Receipt will establish the filing date of the application.**

**National Stage of an International Application under 35 U.S.C. 371**

**If a timely submission to enter the national stage of an international application is compliant with the conditions of 35 U.S.C. 371 and other applicable requirements a Form PCT/DO/EO/903 indicating acceptance of the application as a national stage submission under 35 U.S.C. 371 will be issued in addition to the Filing Receipt, in due course.**

**New International Application Filed with the USPTO as a Receiving Office**

**If a new international application is being filed and the international application includes the necessary components for an international filing date (see PCT Article 11 and MPEP 1810), a Notification of the International Application Number and of the International Filing Date (Form PCT/RO/105) will be issued in due course, subject to prescriptions concerning national security, and the date shown on this Acknowledgement Receipt will establish the international filing date of the application.**

**IN THE UNITED STATES PATENT AND TRADEMARK OFFICE**

In re: LeBoeuf, *et al.*  
Serial No.: 14/184,396  
Filed: February 19, 2014

For: **METHODS AND APPARATUS FOR GENERATING DATA STRINGS OUTPUT  
CONTAINING PHYSIOLOGICAL AND MOTION-RELATED INFORMATION**  
(*As Amended*)

Date: March 31, 2014

Mail Stop Patent Application  
Commissioner for Patents  
P.O. Box 1450  
Alexandria, VA 22313-1450

**SECOND PRELIMINARY AMENDMENT**

Please enter the following Preliminary Amendment before examining the present application. Applicants provide the present Amendment pursuant to the rules stated in revised 37 C.F.R. 1.121 that became effective on July 30, 2003.

**In the Title:**

Please amend the Title as follows:

METHODS AND APPARATUS FOR GENERATING DATA ~~STRINGS~~ OUTPUT  
CONTAINING PHYSIOLOGICAL AND MOTION-RELATED INFORMATION

**In the Claims:**

1. (Currently Amended) A method of generating [[a]] data string output containing physiological and motion-related information, the method comprising:  
sensing physical activity of a subject via at least one motion sensor attached to the subject;  
sensing physiological information from the subject via at least one photoplethysmography (PPG) sensor attached to the subject; and  
processing signals from the at least one motion sensor and signals from the at least one PPG sensor into a serial data string output of physiological information and motion-related information, wherein a plurality of subject physiological parameters can be extracted from the physiological information, and wherein a plurality of subject physical activity parameters can be extracted from the motion-related information.

2. (Original) The method of Claim 1, wherein the plurality of subject physical activity parameters that can be extracted from the motion-related information comprise at least two of the following: exertion, activity level, distance traveled, speed, step count, steps/second, pace, limb motion, poise, performance of an activity, mastication rate, mastication intensity, and mastication volume.

3. (Original) The method of Claim 1, wherein the plurality of subject physiological parameters that can be extracted from the physiological information comprise at least two of the following: blood flow, blood pulse volume, heart rate, blood analyte levels, breathing rate or volume, blood oxygen levels, blood pressure,  $VO_{2max}$ , the 1st derivative of at least one blood pulse, and the 2nd derivative of at least one blood pulse.

4. (Currently Amended) The method of Claim 1, wherein the serial data string output is parsed out such that an application-specific interface (API) can utilize the physiological information and motion-related information for an application.



5. (Original) The method of Claim 4, wherein the application is configured to generate statistical relationships between subject physiological parameters and subject physical activity parameters in the physiological information and motion-related information.

6. (Original) The method of Claim 5, wherein the application is configured to generate statistical relationships between subject physiological parameters and subject physical activity parameters via at least one of the following: principal component analysis, multiple linear regression, machine learning, and Bland-Altman plots.

7. (Currently Amended) The method of Claim 1, further comprising filtering subject motion noise from the signals from the at least one PPG sensor prior to processing signals from the at least one motion sensor and signals from the at least one PPG sensor into the serial data string output.

8. (Original) The method of Claim 7, wherein the subject motion noise comprises subject footstep noise.

9. (Original) The method of Claim 7, wherein filtering subject motion noise from the signals from the at least one PPG sensor comprises at least one of the following: FIR (Finite Impulse Response) filtering, IIR (Infinite Impulse Response) filtering, adaptive filtering, phase filtering, and frequency filtering.

10. (Original) The method of Claim 1, wherein the at least one motion sensor comprises at least one of the following: an optical sensor, an inertial sensor, an electrically conductive sensor, a capacitive sensor, an inductive sensor, an accelerometer, and a blocked channel sensor.

11. (Original) The method of Claim 1, wherein the at least one PPG sensor comprises at least one optical emitter, at least one optical detector, and at least one light guide.

12. (Original) The method of Claim 1, wherein the at least one motion sensor and the at least one PPG sensor are integrated into a wearable device.

13. (Original) The method of Claim 12, wherein the wearable device is configured to be attached to the subject at one or more of the following body locations: an ear, a limb, the nose, and a digit.

14. (Original) The method of Claim 1 wherein the physiological information and/or motion-related information comprises information on data integrity.

15. (Original) A wearable device, comprising:  
a housing; and  
a chipset enclosed within the housing, the chipset comprising at least one PPG sensor, at least one motion sensor, and at least one signal processor;  
wherein the housing comprises at least one window that optically exposes the at least one PPG sensor to a body of a subject wearing the device.

16. (Original) The device of Claim 15, further comprising at least one light guide in optical communication with the at least one PPG sensor and the window.

17. (Original) The device of Claim 15, wherein the wearable device is an earbud.

18. (Original) The device of Claim 15, wherein the wearable device is a headset.

19. (Currently Amended) The device of Claim 15, wherein the at least one signal processor is configured to process signals from the at least one motion sensor and signals from the at least one PPG sensor into a serial data string output of physiological information and motion-related information, wherein a plurality of subject physiological parameters can be extracted from the physiological information, and wherein a plurality of subject physical activity parameters can be extracted from the motion-related information.

20. (Original) The device of Claim 15,

wherein the plurality of subject physical activity parameters that can be extracted from the motion-related information comprise at least two of the following: exertion, activity level, distance traveled, speed, step count, steps/second, pace, limb motion, poise, performance of an activity, mastication rate, mastication intensity, and mastication volume; and

wherein the plurality of subject physiological parameters that can be extracted from the physiological information comprise at least two of the following: blood flow, blood pulse volume, heart rate, blood analyte levels, breathing rate or volume, blood oxygen levels, blood pressure,  $VO_{2max}$ , the 1st derivative of at least one blood pulse, and the 2nd derivative of at least one blood pulse.

21. (Currently Amended) The device of Claim 19, wherein the at least one processor is configured to filter subject motion noise from the signals from the at least one PPG sensor prior to processing signals from the at least one motion sensor and signals from the at least one PPG sensor into the serial data ~~string~~ output.

22. (Original) The device of Claim 21, wherein the subject motion noise comprises subject footstep noise.

23. (Original) The device of Claim 21, wherein the at least one processor is configured to filter subject motion noise from the signals from the at least one PPG sensor via at least one of the following: FIR (Finite Impulse Response) filtering, IIR (Infinite Impulse Response) filtering, adaptive filtering, phase filtering, and frequency filtering.

24. (Original) The device of Claim 15, wherein the at least one motion sensor comprises at least one of the following: an optical sensor, an inertial sensor, an electrically conductive sensor, a capacitive sensor, an inductive sensor, an accelerometer, and a blocked channel sensor.

**REMARKS**

Applicants have amended the Title and have amended Claims 1, 4, 7, 19, and 21, as indicated above, for clarification. Entry of this Preliminary Amendment, examination of the application, and allowance of the application, including Claims 1-24 are respectfully requested.

Respectfully submitted,



Needham J. Boddie, II  
Attorney for Applicants  
Registration No. 40,519

USPTO Customer No. 20792  
Myers Bigel Sibley & Sajovec, P.A.  
Post Office Box 37428  
Raleigh, North Carolina 27627  
Telephone: (919) 854-1400  
Facsimile: (919) 854-1401  
Doc. No. 1490942

**CERTIFICATION OF TRANSMISSION**

I hereby certify that this correspondence is being transmitted via the Office electronic filing system in accordance with 37 C.F.R. § 1.6(a)(4) to the U.S. Patent and Trademark Office on **March 31, 2014**.



---

Gwen R. Bailey

## Electronic Acknowledgement Receipt

<b>EFS ID:</b>	18625434
<b>Application Number:</b>	14184396
<b>International Application Number:</b>	
<b>Confirmation Number:</b>	8272
<b>Title of Invention:</b>	METHODS AND APPARATUS FOR GENERATING DATA STRINGS CONTAINING PHYSIOLOGICAL AND MOTION-RELATED INFORMATION
<b>First Named Inventor/Applicant Name:</b>	Steven Francis LeBoeuf
<b>Customer Number:</b>	20792
<b>Filer:</b>	Needham J. Boddie/Gwen Bailey
<b>Filer Authorized By:</b>	Needham J. Boddie
<b>Attorney Docket Number:</b>	9653-7TSCT2
<b>Receipt Date:</b>	31-MAR-2014
<b>Filing Date:</b>	19-FEB-2014
<b>Time Stamp:</b>	13:38:12
<b>Application Type:</b>	Utility under 35 USC 111(a)

### Payment information:

Submitted with Payment	no
------------------------	----

### File Listing:

Document Number	Document Description	File Name	File Size(Bytes)/ Message Digest	Multi Part /.zip	Pages (if appl.)
1		9653-3TSCT2_SecondPrelimAmendment.pdf	501782 <small>d0512e2d432b35a276b9d0205190e564389438b8</small>	yes	7

<b>Multipart Description/PDF files in .zip description</b>			
<b>Document Description</b>		<b>Start</b>	<b>End</b>
Preliminary Amendment		1	1
Specification		2	2
Claims		3	6
Applicant Arguments/Remarks Made in an Amendment		7	7

**Warnings:**

**Information:**

<b>Total Files Size (in bytes):</b>	501782
-------------------------------------	--------

**This Acknowledgement Receipt evidences receipt on the noted date by the USPTO of the indicated documents, characterized by the applicant, and including page counts, where applicable. It serves as evidence of receipt similar to a Post Card, as described in MPEP 503.**

**New Applications Under 35 U.S.C. 111**

**If a new application is being filed and the application includes the necessary components for a filing date (see 37 CFR 1.53(b)-(d) and MPEP 506), a Filing Receipt (37 CFR 1.54) will be issued in due course and the date shown on this Acknowledgement Receipt will establish the filing date of the application.**

**National Stage of an International Application under 35 U.S.C. 371**

**If a timely submission to enter the national stage of an international application is compliant with the conditions of 35 U.S.C. 371 and other applicable requirements a Form PCT/DO/EO/903 indicating acceptance of the application as a national stage submission under 35 U.S.C. 371 will be issued in addition to the Filing Receipt, in due course.**

**New International Application Filed with the USPTO as a Receiving Office**

**If a new international application is being filed and the international application includes the necessary components for an international filing date (see PCT Article 11 and MPEP 1810), a Notification of the International Application Number and of the International Filing Date (Form PCT/RO/105) will be issued in due course, subject to prescriptions concerning national security, and the date shown on this Acknowledgement Receipt will establish the international filing date of the application.**

Under the Paperwork Reduction Act of 1995, no persons are required to respond to a collection of information unless it displays a valid OMB control number.

<b>PATENT APPLICATION FEE DETERMINATION RECORD</b> Substitute for Form PTO-875	Application or Docket Number <b>14/184,396</b>	Filing Date <b>02/19/2014</b>	<input type="checkbox"/> To be Mailed
---	---	----------------------------------	---------------------------------------

ENTITY:  LARGE  SMALL  MICRO

**APPLICATION AS FILED – PART I**

FOR	NUMBER FILED	NUMBER EXTRA	RATE (\$)	FEE (\$)
<input type="checkbox"/> BASIC FEE <small>(37 CFR 1.16(a), (b), or (c))</small>	N/A	N/A	N/A	
<input type="checkbox"/> SEARCH FEE <small>(37 CFR 1.16(k), (l), or (m))</small>	N/A	N/A	N/A	
<input type="checkbox"/> EXAMINATION FEE <small>(37 CFR 1.16(o), (p), or (q))</small>	N/A	N/A	N/A	
TOTAL CLAIMS <small>(37 CFR 1.16(i))</small>	minus 20 =	*	X \$ =	
INDEPENDENT CLAIMS <small>(37 CFR 1.16(h))</small>	minus 3 =	*	X \$ =	
<input type="checkbox"/> APPLICATION SIZE FEE <small>(37 CFR 1.16(s))</small>	If the specification and drawings exceed 100 sheets of paper, the application size fee due is \$310 (\$155 for small entity) for each additional 50 sheets or fraction thereof. See 35 U.S.C. 41(a)(1)(G) and 37 CFR 1.16(s).			
<input type="checkbox"/> MULTIPLE DEPENDENT CLAIM PRESENT <small>(37 CFR 1.16(j))</small>				
* If the difference in column 1 is less than zero, enter "0" in column 2.			TOTAL	

**APPLICATION AS AMENDED – PART II**

	(Column 1)	(Column 2)	(Column 3)	PRESENT EXTRA	RATE (\$)	ADDITIONAL FEE (\$)
<b>AMENDMENT</b>	<b>03/31/2014</b>	CLAIMS REMAINING AFTER AMENDMENT	HIGHEST NUMBER PREVIOUSLY PAID FOR			
	Total <small>(37 CFR 1.16(i))</small>	* 24	Minus	** 24	= 0	X \$80 = 0
	Independent <small>(37 CFR 1.16(h))</small>	* 2	Minus	***3	= 0	X \$420 = 0
	<input type="checkbox"/> Application Size Fee <small>(37 CFR 1.16(s))</small>					
<input type="checkbox"/> FIRST PRESENTATION OF MULTIPLE DEPENDENT CLAIM <small>(37 CFR 1.16(j))</small>						
					TOTAL ADD'L FEE	<b>0</b>

	(Column 1)	(Column 2)	(Column 3)	PRESENT EXTRA	RATE (\$)	ADDITIONAL FEE (\$)
<b>AMENDMENT</b>		CLAIMS REMAINING AFTER AMENDMENT	HIGHEST NUMBER PREVIOUSLY PAID FOR			
	Total <small>(37 CFR 1.16(i))</small>	*	Minus	**	=	X \$ =
	Independent <small>(37 CFR 1.16(h))</small>	*	Minus	***	=	X \$ =
	<input type="checkbox"/> Application Size Fee <small>(37 CFR 1.16(s))</small>					
<input type="checkbox"/> FIRST PRESENTATION OF MULTIPLE DEPENDENT CLAIM <small>(37 CFR 1.16(j))</small>						
					TOTAL ADD'L FEE	

\* If the entry in column 1 is less than the entry in column 2, write "0" in column 3.  
 \*\* If the "Highest Number Previously Paid For" IN THIS SPACE is less than 20, enter "20".  
 \*\*\* If the "Highest Number Previously Paid For" IN THIS SPACE is less than 3, enter "3".  
 The "Highest Number Previously Paid For" (Total or Independent) is the highest number found in the appropriate box in column 1.

LIE  
/ANNETTE COWAN/

This collection of information is required by 37 CFR 1.16. The information is required to obtain or retain a benefit by the public which is to file (and by the USPTO to process) an application. Confidentiality is governed by 35 U.S.C. 122 and 37 CFR 1.14. This collection is estimated to take 12 minutes to complete, including gathering, preparing, and submitting the completed application form to the USPTO. Time will vary depending upon the individual case. Any comments on the amount of time you require to complete this form and/or suggestions for reducing this burden, should be sent to the Chief Information Officer, U.S. Patent and Trademark Office, U.S. Department of Commerce, P.O. Box 1450, Alexandria, VA 22313-1450. DO NOT SEND FEES OR COMPLETED FORMS TO THIS ADDRESS. **SEND TO: Commissioner for Patents, P.O. Box 1450, Alexandria, VA 22313-1450.**

*If you need assistance in completing the form, call 1-800-PTO-9199 and select option 2.*

<b>INFORMATION DISCLOSURE STATEMENT BY APPLICANT</b> <i>(use as many sheets as necessary)</i>				<b>Complete if Known</b>	
				Application Number	14/184,396
				Filing Date	February 19, 2014
				First Named Inventor	Steven Francis LeBoeuf
				Art Unit	3777
				Examiner Name	
Sheet	<b>C1</b>	of	<b>C1</b>	Attorney Docket Number	9653-7TSCT2

U.S. PATENT DOCUMENTS						
Examiner Initials*	Cite No.	Document Number		Publication Date MM-DD-YYYY	Name of Patentee or Applicant of Cited Document	Pages, Columns, Lines, Where Relevant Passages or Relevant Figures Appear
		Number-Kind Code (if known)				
	1.	US-	2010/0298653	11-2010	McCombie et al.	
	2.	US-	2010/0168531	07-2010	Shaltis et al.	
	3.	US-	2005/0043600	02-2005	Diab et al.	
	4.	US-	5,596,987	01-1997	Chance	
	5.	US-	5,086,229	02-1992	Rosenthal et al.	

FOREIGN PATENT DOCUMENTS							
Examiner Initials*	Cite No.	Foreign Patent Document		Publication Date MM-DD-YYYY	Name of Patentee or Applicant of Cited Document	Pages, Columns, Lines, Where Relevant Passages or Relevant Figures Appear	T
		Country Code, Number, Kind Code (if known)					

NON PATENT LITERATURE DOCUMENTS			
Examiner Initials*	Cite No.	Include name of the author (in CAPITAL LETTERS), title of the article (when appropriate), title of the item (book, magazine, journal, serial, symposium, catalog, etc.), date, page(s), volume-issue number(s), publisher, city and/or country where published	T

Examiner Signature		Date Considered	
--------------------	--	-----------------	--

\*EXAMINER: Initial if reference considered, whether or not citation is in conformance with MPEP 609. Draw line through citation if not in conformance and not considered. Include copy of this form with next communication to applicant.



## Electronic Acknowledgement Receipt

<b>EFS ID:</b>	18723444
<b>Application Number:</b>	14184396
<b>International Application Number:</b>	
<b>Confirmation Number:</b>	8272
<b>Title of Invention:</b>	METHODS AND APPARATUS FOR GENERATING DATA OUTPUT CONTAINING PHYSIOLOGICAL AND MOTION-RELATED INFORMATION
<b>First Named Inventor/Applicant Name:</b>	Steven Francis LeBoeuf
<b>Customer Number:</b>	20792
<b>Filer:</b>	Needham J. Boddie/Gwen Bailey
<b>Filer Authorized By:</b>	Needham J. Boddie
<b>Attorney Docket Number:</b>	9653-7TSCT2
<b>Receipt Date:</b>	10-APR-2014
<b>Filing Date:</b>	19-FEB-2014
<b>Time Stamp:</b>	10:09:54
<b>Application Type:</b>	Utility under 35 USC 111(a)

### Payment information:

Submitted with Payment	no
------------------------	----

### File Listing:

Document Number	Document Description	File Name	File Size(Bytes)/ Message Digest	Multi Part /.zip	Pages (if appl.)
1		9653-7TSCT2_IDS.pdf	287785 45dda3949c2c526f531a704b06545a5b6cf85c8b	yes	3

<b>Multipart Description/PDF files in .zip description</b>			
<b>Document Description</b>		<b>Start</b>	<b>End</b>
Transmittal Letter		1	2
Information Disclosure Statement (IDS) Form (SB08)		3	3

**Warnings:**

**Information:**

<b>Total Files Size (in bytes):</b>	287785
-------------------------------------	--------

**This Acknowledgement Receipt evidences receipt on the noted date by the USPTO of the indicated documents, characterized by the applicant, and including page counts, where applicable. It serves as evidence of receipt similar to a Post Card, as described in MPEP 503.**

**New Applications Under 35 U.S.C. 111**

**If a new application is being filed and the application includes the necessary components for a filing date (see 37 CFR 1.53(b)-(d) and MPEP 506), a Filing Receipt (37 CFR 1.54) will be issued in due course and the date shown on this Acknowledgement Receipt will establish the filing date of the application.**

**National Stage of an International Application under 35 U.S.C. 371**

**If a timely submission to enter the national stage of an international application is compliant with the conditions of 35 U.S.C. 371 and other applicable requirements a Form PCT/DO/EO/903 indicating acceptance of the application as a national stage submission under 35 U.S.C. 371 will be issued in addition to the Filing Receipt, in due course.**

**New International Application Filed with the USPTO as a Receiving Office**

**If a new international application is being filed and the international application includes the necessary components for an international filing date (see PCT Article 11 and MPEP 1810), a Notification of the International Application Number and of the International Filing Date (Form PCT/RO/105) will be issued in due course, subject to prescriptions concerning national security, and the date shown on this Acknowledgement Receipt will establish the international filing date of the application.**

IN THE UNITED STATES PATENT AND TRADEMARK OFFICE

In re: LeBoeuf et al.  
Serial No.: 14/184,396  
Filed: February 19, 2014

Confirmation No.: 8272  
Group Art Unit: 3777

For: **METHODS AND APPARATUS FOR GENERATING DATA STRINGS CONTAINING  
PHYSIOLOGICAL AND MOTION-RELATED INFORMATION**

Date: April 10, 2014

Commissioner for Patents  
Box 1450  
Alexandria, VA 22313-1450

**INFORMATION DISCLOSURE STATEMENT COVER LETTER**

Sir:

Attached is an Information Disclosure Statement listing of documents, together with a copy of any listed foreign patent document and/or non-patent literature. A copy of any listed U.S. patent and/or U.S. patent application publication is not provided herewith in accordance with 37 C.F.R. § 1.98(a)(2)(ii).

- In accordance with **37 CFR 1.97(b)**, the information disclosure statement is being filed:
- (1) within three months of the filing date of a national application other than a continued prosecution application under §1.53(d);
  - (2) within three months of the date of entry of the national stage as set forth in §1.491 in an international application;
  - (3) before the mailing of a first Office Action on the merits; or
  - (4) before the mailing of a first Office Action after the filing of a request for continued examination under §1.114.

In accordance with **37 CFR 1.97(c)**, the information disclosure statement is being filed after the period specified in 37 CFR 1.97(b) above, but before the mailing date of any of a final action under §1.113, a notice of allowance under §1.311, or an action that otherwise closes prosecution in the application, and is accompanied by one of the following:

- (1) The statement specified under **37 CFR 1.97(e)**, as follows:
  - Each item of information contained in the information disclosure statement was first cited in any communication from a foreign patent office in a counterpart foreign application not more than three months prior to the filing of the information disclosure statement; or
  - No item of information contained in the information disclosure statement was cited in a communication from a foreign patent office in a counterpart foreign application, and, to the knowledge of the person signing the certification after making reasonable inquiry, no item of information contained in the information disclosure statement was known to any individual designated in §1.56(c) more than three months prior to the filing of the information disclosure statement; or

- (2) The fee set forth in §1.17(p);

In accordance with **37 CFR 1.97(d)**, the information disclosure statement is being filed after the period specified in 37 CFR 1.97(c) above, but on or before payment of the issue fee, and is accompanied by both of the following:

(1) The statement specified under **37 CFR 1.97(e)**, as follows:

That each item of information contained in the information disclosure statement was first cited in any communication from a foreign patent office in a counterpart foreign application not more than three months prior to the filing of the information disclosure statement; or

That no item of information contained in the information disclosure statement was cited in a communication from a foreign patent office in a counterpart foreign application, and, to the knowledge of the person signing the certification after making reasonable inquiry, no item of information contained in the information disclosure statement was known to any individual designated in §1.56(c) more than three months prior to the filing of the information disclosure statement; and

(2) The fee set forth in §1.17(p);

In accordance with **37 CFR 1.97(g)**, the information disclosure statement shall not be construed as a representation that a search has been made.

In accordance with **37 CFR 1.97(h)**, the information disclosure statement shall not be construed to be an admission that the information cited in the statement is, or is considered to be, material to patentability as defined in §1.56(b).

The Director is hereby authorized to charge the fee specified in 37 C.F.R. § 1.17(p), and any fee deficiency or credit any overpayment, to Deposit Account No. 50-0220; or

No fee is believed due. However, the Director is hereby authorized to charge any deficiency or credit any overpayment to Deposit Account No. 50-0220.

Respectfully submitted,



Needham J. Boddie, II  
Registration No. 40,519  
Attorney for Applicant

**Customer Number 20792**

Myers Bigel Sibley & Sajovec, P.A.  
P.O. Box 37428, Raleigh, NC 27627  
919-854-1400  
919-854-1401 (Fax)

**CERTIFICATION OF TRANSMISSION**

I hereby certify that this correspondence is being transmitted via the Office electronic filing system in accordance with § 1.6(a)(4) to the U.S. Patent and Trademark Office on **April 10, 2014**.

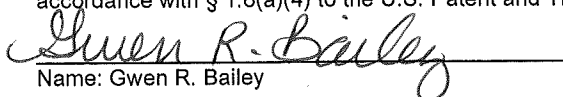

Name: Gwen R. Bailey

<b>INFORMATION DISCLOSURE STATEMENT BY APPLICANT</b>  <i>(use as many sheets as necessary)</i>				<b>Complete if Known</b>	
				Application Number	14/184,396
				Filing Date	February 19, 2014
				First Named Inventor	Steven Francis LeBoeuf
				Art Unit	3777
				Examiner Name	
Sheet	<b>D1</b>	of	<b>D1</b>	Attorney Docket Number	9653-7TSCT2

U.S. PATENT DOCUMENTS						
Examiner Initials*	Cite No.	Document Number		Publication Date MM-DD-YYYY	Name of Patentee or Applicant of Cited Document	Pages, Columns, Lines, Where Relevant Passages or Relevant Figures Appear
		Number-Kind Code (if known)				
	1.	US-	2004/0225207	11-2004	Bae et al.	
		US-				
		US-				
		US-				
		US-				

FOREIGN PATENT DOCUMENTS							
Examiner Initials*	Cite No.	Foreign Patent Document		Publication Date MM-DD-YYYY	Name of Patentee or Applicant of Cited Document	Pages, Columns, Lines, Where Relevant Passages or Relevant Figures Appear	T
		Country Code, Number, Kind Code (if known)					

NON PATENT LITERATURE DOCUMENTS			
Examiner Initials*	Cite No.	Include name of the author (in CAPITAL LETTERS), title of the article (when appropriate), title of the item (book, magazine, journal, serial, symposium, catalog, etc.), date, page(s), volume-issue number(s), publisher, city and/or country where published	T

Examiner Signature		Date Considered	
--------------------	--	-----------------	--

\*EXAMINER: Initial if reference considered, whether or not citation is in conformance with MPEP 609. Draw line through citation if not in conformance and not considered. Include copy of this form with next communication to applicant.

## Electronic Acknowledgement Receipt

<b>EFS ID:</b>	19116310
<b>Application Number:</b>	14184396
<b>International Application Number:</b>	
<b>Confirmation Number:</b>	8272
<b>Title of Invention:</b>	METHODS AND APPARATUS FOR GENERATING DATA OUTPUT CONTAINING PHYSIOLOGICAL AND MOTION-RELATED INFORMATION
<b>First Named Inventor/Applicant Name:</b>	Steven Francis LeBoeuf
<b>Customer Number:</b>	20792
<b>Filer:</b>	Needham J. Boddie/Gwen Bailey
<b>Filer Authorized By:</b>	Needham J. Boddie
<b>Attorney Docket Number:</b>	9653-7TSCT2
<b>Receipt Date:</b>	23-MAY-2014
<b>Filing Date:</b>	19-FEB-2014
<b>Time Stamp:</b>	14:32:29
<b>Application Type:</b>	Utility under 35 USC 111(a)

### Payment information:

Submitted with Payment	no
------------------------	----

### File Listing:

Document Number	Document Description	File Name	File Size(Bytes)/ Message Digest	Multi Part /.zip	Pages (if appl.)
1		9653-7TSCT2_IDS.pdf	287639 <small>739913423bf6e4095e64ce6d2c5ead91b5e7f64d</small>	yes	3

<b>Multipart Description/PDF files in .zip description</b>			
<b>Document Description</b>		<b>Start</b>	<b>End</b>
Transmittal Letter		1	2
Information Disclosure Statement (IDS) Form (SB08)		3	3

**Warnings:**

**Information:**

<b>Total Files Size (in bytes):</b>	287639
-------------------------------------	--------

**This Acknowledgement Receipt evidences receipt on the noted date by the USPTO of the indicated documents, characterized by the applicant, and including page counts, where applicable. It serves as evidence of receipt similar to a Post Card, as described in MPEP 503.**

**New Applications Under 35 U.S.C. 111**

**If a new application is being filed and the application includes the necessary components for a filing date (see 37 CFR 1.53(b)-(d) and MPEP 506), a Filing Receipt (37 CFR 1.54) will be issued in due course and the date shown on this Acknowledgement Receipt will establish the filing date of the application.**

**National Stage of an International Application under 35 U.S.C. 371**

**If a timely submission to enter the national stage of an international application is compliant with the conditions of 35 U.S.C. 371 and other applicable requirements a Form PCT/DO/EO/903 indicating acceptance of the application as a national stage submission under 35 U.S.C. 371 will be issued in addition to the Filing Receipt, in due course.**

**New International Application Filed with the USPTO as a Receiving Office**

**If a new international application is being filed and the international application includes the necessary components for an international filing date (see PCT Article 11 and MPEP 1810), a Notification of the International Application Number and of the International Filing Date (Form PCT/RO/105) will be issued in due course, subject to prescriptions concerning national security, and the date shown on this Acknowledgement Receipt will establish the international filing date of the application.**

## IN THE UNITED STATES PATENT AND TRADEMARK OFFICE

In re: LeBoeuf et al.

Confirmation No.: 8272

Serial No.: 14/184,396

Group Art Unit: 3777

Filed: February 19, 2014

For: **METHODS AND APPARATUS FOR GENERATING DATA STRINGS CONTAINING  
PHYSIOLOGICAL AND MOTION-RELATED INFORMATION**

Date: May 23, 2014

Commissioner for Patents  
Box 1450  
Alexandria, VA 22313-1450**INFORMATION DISCLOSURE STATEMENT COVER LETTER**

Sir:

Attached is an Information Disclosure Statement listing of documents, together with a copy of any listed foreign patent document and/or non-patent literature. A copy of any listed U.S. patent and/or U.S. patent application publication is not provided herewith in accordance with 37 C.F.R. § 1.98(a)(2)(ii).

- In accordance with **37 CFR 1.97(b)**, the information disclosure statement is being filed:
- (1) within three months of the filing date of a national application other than a continued prosecution application under §1.53(d);
  - (2) within three months of the date of entry of the national stage as set forth in §1.491 in an international application;
  - (3) before the mailing of a first Office Action on the merits; or
  - (4) before the mailing of a first Office Action after the filing of a request for continued examination under §1.114.

In accordance with **37 CFR 1.97(c)**, the information disclosure statement is being filed after the period specified in 37 CFR 1.97(b) above, but before the mailing date of any of a final action under §1.113, a notice of allowance under §1.311, or an action that otherwise closes prosecution in the application, and is accompanied by one of the following:

- (1) The statement specified under **37 CFR 1.97(e)**, as follows:
- Each item of information contained in the information disclosure statement was first cited in any communication from a foreign patent office in a counterpart foreign application not more than three months prior to the filing of the information disclosure statement; or
  - No item of information contained in the information disclosure statement was cited in a communication from a foreign patent office in a counterpart foreign application, and, to the knowledge of the person signing the certification after making reasonable inquiry, no item of information contained in the information disclosure statement was known to any individual designated in §1.56(c) more than three months prior to the filing of the information disclosure statement; or

- (2) The fee set forth in §1.17(p);

In accordance with **37 CFR 1.97(d)**, the information disclosure statement is being filed after the period specified in 37 CFR 1.97(c) above, but on or before payment of the issue fee, and is accompanied by both of the following:



(1) The statement specified under **37 CFR 1.97(e)**, as follows:

That each item of information contained in the information disclosure statement was first cited in any communication from a foreign patent office in a counterpart foreign application not more than three months prior to the filing of the information disclosure statement; or

That no item of information contained in the information disclosure statement was cited in a communication from a foreign patent office in a counterpart foreign application, and, to the knowledge of the person signing the certification after making reasonable inquiry, no item of information contained in the information disclosure statement was known to any individual designated in §1.56(c) more than three months prior to the filing of the information disclosure statement; and

(2) The fee set forth in §1.17(p);

In accordance with **37 CFR 1.97(g)**, the information disclosure statement shall not be construed as a representation that a search has been made.

In accordance with **37 CFR 1.97(h)**, the information disclosure statement shall not be construed to be an admission that the information cited in the statement is, or is considered to be, material to patentability as defined in §1.56(b).

The Director is hereby authorized to charge the fee specified in 37 C.F.R. § 1.17(p), and any fee deficiency or credit any overpayment, to Deposit Account No. 50-0220; or

No fee is believed due. However, the Director is hereby authorized to charge any deficiency or credit any overpayment to Deposit Account No. 50-0220.

Respectfully submitted,



Needham J. Boddie, II  
Registration No. 40,519  
Attorney for Applicant

**Customer Number 20792**

Myers Bigel Sibley & Sajovec, P.A.  
P.O. Box 37428, Raleigh, NC 27627  
919-854-1400  
919-854-1401 (Fax)

**CERTIFICATION OF TRANSMISSION**

I hereby certify that this correspondence is being transmitted via the Office electronic filing system in accordance with § 1.6(a)(4) to the U.S. Patent and Trademark Office on **May 23, 2014**.

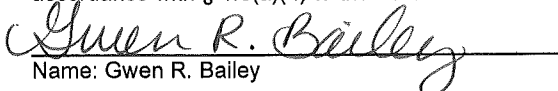
  
Name: Gwen R. Bailey



UNITED STATES PATENT AND TRADEMARK OFFICE

UNITED STATES DEPARTMENT OF COMMERCE
United States Patent and Trademark Office
Address: COMMISSIONER FOR PATENTS
P.O. Box 1450
Alexandria, Virginia 22313-1450
www.uspto.gov

Table with 5 columns: APPLICATION NO., FILING DATE, FIRST NAMED INVENTOR, ATTORNEY DOCKET NO., CONFIRMATION NO.
14/184,396 02/19/2014 Steven Francis LeBoeuf 9653-7TSCT2 8272

20792 7590 06/03/2014
MYERS BIGEL SIBLEY & SAJOVEC
PO BOX 37428
RALEIGH, NC 27627

EXAMINER

FULLER, RODNEY EVAN

ART UNIT PAPER NUMBER

2852

MAIL DATE DELIVERY MODE

06/03/2014

PAPER

Please find below and/or attached an Office communication concerning this application or proceeding.

The time period for reply, if any, is set in the attached communication.



Continuation of Attachment(s) 2). Information Disclosure Statement(s) (PTO/SB/08), Paper No(s)/Mail Date :02/19/2014, 03/18/2014, 04/10/2014, 05/23/2014.

### **DETAILED ACTION**

1. The present application is being examined under the pre-AIA first to invent provisions.

#### ***Specification***

2. The disclosure is objected to because of the following informalities:

The first paragraph of the Specification (i.e., Related Applications) should include the status of the parent application No. 12/691,388, i.e., now U.S. Patent No. 8,700,111.

Appropriate correction is required.

#### ***Double Patenting***

3. The nonstatutory double patenting rejection is based on a judicially created doctrine grounded in public policy (a policy reflected in the statute) so as to prevent the unjustified or improper timewise extension of the “right to exclude” granted by a patent and to prevent possible harassment by multiple assignees. A nonstatutory double patenting rejection is appropriate where the claims at issue are not identical, but at least one examined application claim is not patentably distinct from the reference claim(s) because the examined application claim is either anticipated by, or would have been obvious over, the reference claim(s). See, e.g., *In re Berg*, 140 F.3d 1428, 46 USPQ2d 1226 (Fed. Cir. 1998); *In re Goodman*, 11 F.3d 1046, 29 USPQ2d 2010 (Fed. Cir. 1993); *In re Longi*, 759 F.2d 887, 225 USPQ 645 (Fed. Cir. 1985); *In re Van Ornum*, 686 F.2d 937, 214 USPQ 761 (CCPA 1982); *In re Vogel*, 422 F.2d 438, 164 USPQ 619 (CCPA 1970); and *In re Thorington*, 418 F.2d 528, 163 USPQ 644 (CCPA 1969).

A timely filed terminal disclaimer in compliance with 37 CFR 1.321(c) or 1.321(d) may be used to overcome an actual or provisional rejection based on a nonstatutory double patenting ground provided the reference application or patent either is shown to be commonly owned with this application, or claims an invention made as a result of activities undertaken within the scope of a joint research agreement. A terminal disclaimer must be signed in compliance with 37 CFR 1.321(b).

The USPTO internet Web site contains terminal disclaimer forms which may be used. Please visit <http://www.uspto.gov/forms/>. The filing date of the application will determine what form should be used. A web-based eTerminal Disclaimer may be filled out completely online using web-screens. An eTerminal Disclaimer that meets all requirements is auto-processed and approved immediately upon submission. For more information about eTerminal Disclaimers, refer to <http://www.uspto.gov/patents/process/file/efs/guidance/eTD-info-I.jsp>.

4. Claims 1-24 are provisionally rejected on the ground of nonstatutory double patenting as being unpatentable over claims 1-20 of copending Application No. 14/194,891. Although the claims at issue are not identical, they are not patentably distinct from each other.

This is a provisional nonstatutory double patenting rejection because the patentably indistinct claims have not in fact been patented.

5. Claims 1-24 are rejected on the ground of nonstatutory double patenting as being unpatentable over claims 1-42 of U.S. Patent No. 8,700,111. Although the claims at issue are not identical, they are not patentably distinct from each other.

***Claim Rejections - 35 USC § 112***

6. The following is a quotation of the first paragraph of 35 U.S.C. 112(a):

(a) IN GENERAL.—The specification shall contain a written description of the invention, and of the manner and process of making and using it, in such full, clear, concise, and exact terms as to enable any person skilled in the art to which it pertains, or with which it is most nearly connected, to make and use the same, and shall set forth the best mode contemplated by the inventor or joint inventor of carrying out the invention.

The following is a quotation of the first paragraph of pre-AIA 35 U.S.C. 112:

The specification shall contain a written description of the invention, and of the manner and process of making and using it, in such full, clear, concise, and exact terms as to enable any person skilled in the art to which it pertains, or with which it is most nearly connected, to make and use the same, and shall set forth the best mode contemplated by the inventor of carrying out his invention.

7. Claims 2 and 20 are rejected under 35 U.S.C. 112(a) or 35 U.S.C. 112 (pre-AIA), first paragraph, as failing to comply with the enablement requirement. The claim(s) contains subject matter which was not described in the specification in such a way as to enable one skilled in the art to which it pertains, or with which it is most nearly connected, to make and/or use the invention. Claims 2 and 20 set forth the limitation " wherein the plurality of subject physical activity parameters that can be extracted from the motion-related information comprise at least two of the following: exertion, activity level, distance traveled, speed, step count, steps/second, pace, limb motion, poise, performance of an activity, mastication rate, mastication intensity, and mastication volume". There is no description to enable signals from "at least one motion sensor" to determine the motion related information in claims 2 and 20, i.e., exertion, activity level, limb motion, poise, performance of an activity, mastication rate, mastication intensity, and mastication volume, etc.

***Claim Rejections - 35 USC § 102***

8. In the event the determination of the status of the application as subject to AIA 35 U.S.C. 102 and 103 (or as subject to pre-AIA 35 U.S.C. 102 and 103) is incorrect, any correction of the statutory basis for the rejection will not be considered a new ground of rejection if the prior art relied upon, and the rationale supporting the rejection, would be the same under either status.

9. The following is a quotation of the appropriate paragraphs of pre-AIA 35 U.S.C. 102 that form the basis for the rejections under this section made in this Office action:

A person shall be entitled to a patent unless –

(e) the invention was described in (1) an application for patent, published under section 122(b), by another filed in the United States before the invention by the applicant for patent or (2) a patent granted on an application for patent by another filed in the United States before the invention by the applicant for patent, except that an international application filed under the treaty defined in section 351(a) shall have the effects for purposes of this subsection of an application filed in the United States only if the international application designated the United States and was published under Article 21(2) of such treaty in the English language.

10. Claims 1-14 are rejected under pre-AIA 35 U.S.C. 102(e) as being anticipated by Dorogusker, et al. (US 2009/0287067).

Regarding claim 1, Dorogusker discloses "sensing physical activity of a subject via at least one motion sensor (paragraph 0032, lines 10-11; paragraph 0051: accelerometer) attached to the subject; sensing physiological information from the subject via at least one photoplethysmography (PPG) sensor (paragraph 0032, lines 1-9) attached to the subject; and processing signals (Fig. 4, ref.# 430: signal processing) from the at least one motion sensor and signals from the at least one PPG sensor into a serial data output (paragraph 0053, lines 6-8: serial interface protocol) of physiological information and motion- related information, wherein a plurality of subject physiological



Art Unit: 2852

parameters can be extracted from the physiological information, and wherein a plurality of subject physical activity parameters can be extracted from the motion-related information (paragraph 0032, lines 1-11).”

Regarding claim 2, Dorogusker discloses “wherein the plurality of subject physical activity parameters that can be extracted from the motion-related information comprise at least two of the following: exertion, activity level, distance traveled, speed, step count, steps/second, pace, limb motion, poise, performance of an activity, mastication rate, mastication intensity, and mastication volume.” (paragraph 0032, lines 9-11)

Regarding claim 3, Dorogusker discloses “wherein the plurality of subject physiological parameters that can be extracted from the physiological information comprise at least two of the following: blood flow, blood pulse volume, heart rate, blood analyte levels, breathing rate or volume, blood oxygen levels, blood pressure, VO<sub>2</sub>max, the 1<sup>st</sup> derivative of at least one blood pulse, and the 2<sup>nd</sup> derivative of at least one blood pulse.” (paragraph 0032, lines 7-8; paragraph 0042, lines 10-14)

Regarding claim 4, Dorogusker discloses “wherein the serial data output is parsed out such that an application-specific interface (API) (Fig. 4, ref.# 416: interface) can utilize the physiological information and motion-related information for an application.” (paragraph 0053, lines 1-8;

Regarding claim 5, Dorogusker discloses “wherein the application is configured to generate statistical relationships between subject physiological parameters and

Art Unit: 2852

subject physical activity parameters in the physiological information and motion-related information.” (paragraph 0032, lines 9-11)

Regarding claim 6, Dorogusker discloses “wherein the application is configured to generate statistical relationships between subject physiological parameters and subject physical activity parameters via at least one of the following: principal component analysis, multiple linear regression, machine learning, and Bland-Altman plots.” (paragraph 0064, 0071: analysis to include standard techniques of data analysis such as principal component analysis, multiple linear regression, etc.)

Regarding claim 7, Dorogusker discloses “filtering subject motion noise from the signals from the at least one PPG sensor prior to processing signals from the at least one motion sensor and signals from the at least one PPG sensor into the serial data output.” (paragraph 0016, lines 8-15)

Regarding claim 8, Dorogusker discloses “wherein the subject motion noise comprises subject footstep noise.” (paragraph 0016, lines 8-15; user's movements, i.e., footstep noise)

Regarding claim 9, Doroguske discloses “wherein filtering subject motion noise from the signals from the at least one PPG sensor comprises at least one of the following: FIR (Finite Impulse Response) filtering, IIR (Infinite Impulse Response) filtering, adaptive filtering, phase filtering, and frequency filtering.” (paragraph 0075, lines 8-20)

Regarding claim 10, Doroguske discloses “wherein the at least one motion sensor comprises at least one of the following: an optical sensor, an inertial sensor, an

Art Unit: 2852

electrically conductive sensor, a capacitive sensor, an inductive sensor, an accelerometer, and a blocked channel sensor.” (paragraph 0051, lines 5-7: accelerometer)

Regarding claim 11, Doroguske discloses “wherein the at least one PPG sensor comprises at least one optical emitter (Fig. 3B, ref.# 312), at least one optical detector (Fig. 3B, ref.# 314), and at least one light guide (Fig. 3B, ref.# 308a).”

Regarding claim 12, Doroguske discloses “wherein the at least one motion sensor and the at least one PPG sensor are integrated into a wearable device.” (Fig. 4)

Regarding claim 13, Doroguske discloses “wherein the wearable device is configured to be attached to the subject at one or more of the following body locations: an ear, a limb, the nose, and a digit.” (Fig. 4: ear)

Regarding claim 14, Doroguske discloses “wherein the physiological information and/or motion-related information comprises information on data integrity.” (paragraph 0016, lines 1-15: data anomalies, i.e., data integrity)

### ***Claim Rejections - 35 USC § 103***

11. The following is a quotation of pre-AIA 35 U.S.C. 103(a) which forms the basis for all obviousness rejections set forth in this Office action:

(a) A patent may not be obtained though the invention is not identically disclosed or described as set forth in section 102 of this title, if the differences between the subject matter sought to be patented and the prior art are such that the subject matter as a whole would have been obvious at the time the invention was made to a person having ordinary skill in the art to which said subject matter pertains. Patentability shall not be negated by the manner in which the invention was made.

Art Unit: 2852

12. Claims 15-24 are rejected under pre-AIA 35 U.S.C. 103(a) as being unpatentable over Dorogusker, et al. (US 2009/0287067) in view of Bae, et al. (US 2008,0177162).

Regarding claim 15, Dorogusker discloses "a housing (Fig. 2, ref.# 204); and a chipset (Fig. 2, ref.# 208 enclosed within the housing, the chipset comprising at least one PPG sensor (Fig. 2, ref.# 218; paragraph 0032, lines 7-10); at least one motion sensor (Fig. 2, ref.# 218; paragraph 0032, lines 10-11), and at least one signal processor (Fig. 4, ref.# 430); wherein the housing comprises at least one window (Fig. 2, ref.# 212) that optically exposes the at least one PPG sensor to a body of a subject wearing the device."

However, the signal processor is not located on the chipset and actually located outside the housing. However, locating a signal processor inside the housing in the same area as the sensors was well known in the art at the time the invention was made as evident from the teaching of Bae (See Fig. 2, ref.#s 510, 511, 514, 515). Thus, it would have been obvious to one of ordinary skill in the art at the time the invention was made to modify Dorogusker by including the signal processor inside the housing on the chip set in order to make the device smaller and thus more comfortable for the user.

Regarding claim 16, Dorogusker discloses "at least one light guide (Fig. 2, area between ref.#s 210, 212) in optical communication with the at least one PPG sensor (Fig. 2, ref.# 218) and the window (Fig. 2, ref.# 212)."

Regarding claim 17, Dorogusker discloses "wherein the wearable device is an earbud." (Figs. 2 and 4)

Regarding claim 18, Dorogusker discloses “wherein the wearable device is a headset.” (Figs. 2 and 4)

Regarding claim 19, Dorogusker discloses “wherein the at least one signal processor (Fig. 4, ref.# 430) is configured to process signals from the at least one motion sensor (paragraph 0032, lines 10-11; paragraph 0051: accelerometer) and signals from the at least one PPG sensor (paragraph 0032, lines 1-9) into a serial data output (paragraph 0053, lines 6-8: serial interface protocol ) of physiological information and motion-related information, wherein a plurality of subject physiological parameters can be extracted from the physiological information, and wherein a plurality of subject physical activity parameters can be extracted from the motion-related information (paragraph 0032, lines 1-11).”

Regarding claim 20, Dorogusker discloses “wherein the plurality of subject physical activity parameters that can be extracted from the motion-related information comprise at least two of the following: exertion, activity level, distance traveled, speed, step count, steps/second, pace, limb motion, poise, performance of an activity, mastication rate, mastication intensity, and mastication volume (paragraph 0032, lines 9-11); and wherein the plurality of subject physiological parameters that can be extracted from the physiological information comprise at least two of the following: blood flow, blood pulse volume, heart rate, blood analyte levels, breathing rate or volume, blood oxygen levels, blood pressure, VO<sub>2</sub>max, the 1<sup>st</sup> derivative of at least one blood pulse, and the 2<sup>nd</sup> derivative of at least one blood pulse (paragraph 0032, lines 7-8; paragraph 0042, lines 10-14).”

Regarding claim 21, Dorogusker discloses “wherein the at least one processor (Fig. 4, ref.\$ 430) is configured to filter subject motion noise from the signals from the at least one PPG sensor prior to processing signals from the at least one motion sensor and signals from the at least one PPG sensor into the serial data output.” (paragraph 0016, lines 8-15)

Regarding claim 22, Dorogusker discloses “wherein the subject motion noise comprises subject footstep noise.” (paragraph 0016, lines 8-15; user's movements, i.e., footstep noise)

Regarding claim 23, Dorogusker discloses “wherein the at least one processor is configured to filter subject motion noise from the signals from the at least one PPG sensor via at least one of the following: FIR (Finite Impulse Response) filtering, IIR (Infinite Impulse Response) filtering, adaptive filtering, phase filtering, and frequency filtering.” (paragraph 0075, lines 8-20)

Regarding claim 24, Dorogusker discloses “wherein the at least one motion sensor comprises at least one of the following: an optical sensor, an inertial sensor, an electrically conductive sensor, a capacitive sensor, an inductive sensor, an accelerometer, and a blocked channel sensor.” (paragraph 0051, lines 5-7: accelerometer)

### ***Conclusion***

13. Any inquiry concerning this communication or earlier communications from the examiner should be directed to RODNEY FULLER whose telephone number is (571)272-2118. The examiner can normally be reached on 8:00am - 4:30pm.

Art Unit: 2852

If attempts to reach the examiner by telephone are unsuccessful, the examiner's supervisor, Clayton Laballe can be reached on 571-272-1594. The fax phone number for the organization where this application or proceeding is assigned is 571-273-8300.

Information regarding the status of an application may be obtained from the Patent Application Information Retrieval (PAIR) system. Status information for published applications may be obtained from either Private PAIR or Public PAIR. Status information for unpublished applications is available through Private PAIR only. For more information about the PAIR system, see <http://pair-direct.uspto.gov>. Should you have questions on access to the Private PAIR system, contact the Electronic Business Center (EBC) at 866-217-9197 (toll-free). If you would like assistance from a USPTO Customer Service Representative or access to the automated information system, call 800-786-9199 (IN USA OR CANADA) or 571-272-1000.

/RODNEY FULLER/  
Primary Examiner, Art Unit 2852

May 30, 2014

<b>Notice of References Cited</b>	Application/Control No. 14/184,396	Applicant(s)/Patent Under Reexamination LEBOEUF ET AL.	
	Examiner RODNEY FULLER	Art Unit 2852	Page 1 of 1

**U.S. PATENT DOCUMENTS**

*	Document Number Country Code-Number-Kind Code	Date MM-YYYY	Name	Classification
*	A US-2009/0287067	11-2009	Dorogusker et al.	600/300
	B US-			
	C US-			
	D US-			
	E US-			
	F US-			
	G US-			
	H US-			
	I US-			
	J US-			
	K US-			
	L US-			
	M US-			

**FOREIGN PATENT DOCUMENTS**

*	Document Number Country Code-Number-Kind Code	Date MM-YYYY	Country	Name	Classification
	N				
	O				
	P				
	Q				
	R				
	S				
	T				

**NON-PATENT DOCUMENTS**

*	Document Number Country Code-Number-Kind Code	Date MM-YYYY	Country	Name	Classification
	Include as applicable: Author, Title Date, Publisher, Edition or Volume, Pertinent Pages)				
	U				
	V				
	W				
	X				

\*A copy of this reference is not being furnished with this Office action. (See MPEP § 707.05(a).)  
Dates in MM-YYYY format are publication dates. Classifications may be US or foreign.



<b>INFORMATION DISCLOSURE STATEMENT BY APPLICANT</b> <i>(use as many sheets as necessary)</i>				<i>Complete if Known</i>	
				Application Number	14/184,396
				Filing Date	February 19, 2014
				First Named Inventor	Steven Francis LeBoeuf
				Art Unit	3777
				Examiner Name	
Sheet	D1	of	D1	Attorney Docket Number	9653-7TSTCT2

U.S. PATENT DOCUMENTS						
Examiner Initials*	Cite No.	Document Number		Publication Date MM-DD-YYYY	Name of Patentee or Applicant of Cited Document	Pages, Columns, Lines, Where Relevant Passages or Relevant Figures Appear
		Number-Kind Code (if known)				
	1.	US-	2004/0225207	11-2004	Bae et al.	
		US-				
		US-				
		US-				
		US-				

FOREIGN PATENT DOCUMENTS							
Examiner Initials*	Cite No.	Foreign Patent Document		Publication Date MM-DD-YYYY	Name of Patentee or Applicant of Cited Document	Pages, Columns, Lines, Where Relevant Passages or Relevant Figures Appear	T
		Country Code, Number, Kind Code (if known)					

NON PATENT LITERATURE DOCUMENTS			
Examiner Initials*	Cite No.	Include name of the author (in CAPITAL LETTERS), title of the article (when appropriate), title of the item (book, magazine, journal, serial, symposium, catalog, etc.), date, page(s), volume-issue number(s), publisher, city and/or country where published	T

Examiner Signature	/Rodney Fuller/	Date Considered	05/29/2014
--------------------	-----------------	-----------------	------------

\*EXAMINER: Initial if reference considered, whether or not citation is in conformance with MPEP 609. Draw line through citation if not in conformance and not considered. Include copy of this form with next communication to applicant.

ALL REFERENCES CONSIDERED EXCEPT WHERE LINED THROUGH. /RF/

<b>INFORMATION DISCLOSURE STATEMENT BY APPLICANT</b> (use as many sheets as necessary)				<i>Complete if Known</i>	
				Application Number	14/184,396
				Filing Date	February 19, 2014
				First Named Inventor	Steven Francis LeBoeuf
				Art Unit	3777
				Examiner Name	
Sheet	C1	of	C1	Attorney Docket Number	9653-7TSCT2

U.S. PATENT DOCUMENTS						
Examiner Initials*	Cite No.	Document Number		Publication Date MM-DD-YYYY	Name of Patentee or Applicant of Cited Document	Pages, Columns, Lines, Where Relevant Passages or Relevant Figures Appear
		Number-Kind Code (if known)				
	1.	US-	2010/0298653	11-2010	McCombie et al.	
	2.	US-	2010/0168531	07-2010	Shaltis et al.	
	3.	US-	2005/0043600	02-2005	Diab et al.	
	4.	US-	5,596,987	01-1997	Chance	
	5.	US-	5,086,229	02-1992	Rosenthal et al.	

FOREIGN PATENT DOCUMENTS							
Examiner Initials*	Cite No.	Foreign Patent Document		Publication Date MM-DD-YYYY	Name of Patentee or Applicant of Cited Document	Pages, Columns, Lines, Where Relevant Passages or Relevant Figures Appear	T
		Country Code, Number, Kind Code (if known)					

NON PATENT LITERATURE DOCUMENTS			
Examiner Initials*	Cite No.	Include name of the author (in CAPITAL LETTERS), title of the article (when appropriate), title of the item (book, magazine, journal, serial, symposium, catalog, etc.), date, page(s), volume-issue number(s), publisher, city and/or country where published	T

ALL REFERENCES CONSIDERED EXCEPT WHERE LINED THROUGH. /RF/

Examiner Signature	/Rodney Fuller/	Date Considered	05/18/2014
--------------------	-----------------	-----------------	------------

\*EXAMINER: Initial if reference considered, whether or not citation is in conformance with MPEP 609. Draw line through citation if not in conformance and not considered. Include copy of this form with next communication to applicant.

<b>INFORMATION DISCLOSURE STATEMENT BY APPLICANT</b>  <i>(use as many sheets as necessary)</i>				<b>Complete if Known</b>	
				Application Number	14/184,396
				Filing Date	February 19, 2014
				First Named Inventor	Steven Francis LeBoeuf
				Art Unit	3777
				Examiner Name	
Sheet	<b>B1</b>	of	<b>B1</b>	Attorney Docket Number	9653-7TSCT2

U.S. PATENT DOCUMENTS						
Examiner Initials*	Cite No.	Document Number		Publication Date MM-DD-YYYY	Name of Patentee or Applicant of Cited Document	Pages, Columns, Lines, Where Relevant Passages or Relevant Figures Appear
		Number-Kind Code (if known)				
	1.	US-	2010/0217103 A1	08-26-2010	Abdul-Hafiz et al.	
	2.	US-	2004/0054291 A1	03-18-2004	Schultz et al.	
	3.	US-	2004/0034293 A1	02-19-2004	Kimball	

FOREIGN PATENT DOCUMENTS							
Examiner Initials*	Cite No.	Foreign Patent Document		Publication Date MM-DD-YYYY	Name of Patentee or Applicant of Cited Document	Pages, Columns, Lines, Where Relevant Passages or Relevant Figures Appear	T
		Country Code, Number, Kind Code (if known)					

NON PATENT LITERATURE DOCUMENTS				
Examiner Initials*	Cite No.	Include name of the author (in CAPITAL LETTERS), title of the article (when appropriate), title of the item (book, magazine, journal, serial, symposium, catalog, etc.), date, page(s), volume-issue number(s), publisher, city and/or country where published		T
	4.	Notification of Transmittal of The International Search Report and The Written Opinion of the International Searching Authority, or the Declaration corresponding to International Application No. PCT/US2013/070271; Date of Mailing: February 26, 2014; International Search Report; Written Opinion of the International Searching Authority; 13 pages		

ALL REFERENCES CONSIDERED EXCEPT WHERE LINED THROUGH. /RF/

Examiner Signature	/Rodney Fuller/	Date Considered	05/18/2014
--------------------	-----------------	-----------------	------------

\*EXAMINER: Initial if reference considered, whether or not citation is in conformance with MPEP 609. Draw line through citation if not in conformance and not considered. Include copy of this form with next communication to applicant.

<b>INFORMATION DISCLOSURE STATEMENT BY APPLICANT</b>  <i>(use as many sheets as necessary)</i>				<b>Complete if Known</b>			
				Application Number		To Be Assigned	
				Filing Date		Concurrently Herewith	
				First Named Inventor		Steven Francis LeBeouf	
				Art Unit			
				Examiner Name			
Sheet	<b>A1</b>	of	<b>A2</b>	Attorney Docket Number	9653-7TSCT2		

U.S. PATENT DOCUMENTS						
Examiner Initials*	Cite No.	Document Number		Publication Date MM-DD-YYYY	Name of Patentee or Applicant of Cited Document	Pages, Columns, Lines, Where Relevant Passages or Relevant Figures Appear
		Number-Kind Code (if known)				
	1.	US-	2013/0131519	05-2013	LeBoeuf et al.	
	2.	US-	2012/0197093	08-2012	LeBoeuf et al.	
	3.	US-	2011/0105869 A1	05-2011	Wilson et al.	
	4.	US-	2009/0287067 A1	11-2009	Dorogusker et al.	
	5.	US-	2009/0270698 A1	10-2009	Shioi et al.	
	6.	US-	2009/0105556 A1	04-2009	Fricke et al.	
	7.	US-	2009/0054752 A1	02-2009	Jonnalagadda et al.	
	8.	US-	2009/0030350 A1	01-29-2009	Yang et al.	
	9.	US-	2008/0177162 A1	07-2008	Bae et al.	
	10.	US-	2008/0165017 A1	07-2008	Schwartz	
	11.	US-	2008/0096726 A1	04-2008	Riley et al.	
	12.	US-	2008/0076972 A1	03-2008	Dorogusker et al.	
	13.	US-	2006/0009685	01-12-2006	Finarov et al.	
	14.	US-	2005/0228299	10-13-2005	Banet	
	15.	US-	2005/0209516	09-22-2005	Fraden	
	16.	US-	2005/0177034 A1	08-2005	Beaumont	
	17.	US-	8,512,242 B2	08-2013	LeBoeuf et al.	
	18.	US-	8,251,903 B2	08-2012	LeBoeuf et al.	
	19.	US-	8,055,319 B2	11-2011	Oh et al.	
	20.	US-	7,209,775 B2	04-2007	Bae et al.	
	21.	US-	6,859,658 B1	02-2005	Krug	
	22.	US-	6,808,473 B2	10-2004	Hisano et al.	
	23.	US-	6,371,925 B1	04-2002	Imai et al.	
	24.	US-	6,783,501 B2	08-31-2001	Takahashi et al.	
	25.	US-	6,080,110 A	06-2000	Thorgersen	
	26.	US-	6,078,829 A	06-2000	Uchida et al.	

FOREIGN PATENT DOCUMENTS							
Examiner Initials*	Cite No.	Foreign Patent Document		Publication Date MM-DD-YYYY	Name of Patentee or Applicant of Cited Document	Pages, Columns, Lines, Where Relevant Passages or Relevant Figures Appear	T
		Country Code, Number, Kind Code (if known)					
	27	WO	2013/038296 A1	03-21-2013	KONINKLIJKE PHILIPS ELECTRONICS N.V.		
	28	JP	2007-185348	07-26-2007	OLYMPUS CORP		
	29	JP	2001-025462	01-30-2001	DENSO CORP		

Examiner Signature	/Rodney Fuller/	Date Considered	05/18/2014
--------------------	-----------------	-----------------	------------

\*EXAMINER: Initial if reference considered, whether or not citation is in conformance with MPEP 609. Draw line through citation if not in conformance and not considered. Include copy of this form with next communication to applicant.

ALL REFERENCES CONSIDERED EXCEPT WHERE LINED THROUGH. /RF/

<b>INFORMATION DISCLOSURE STATEMENT BY APPLICANT</b> <i>(use as many sheets as necessary)</i>				<i>Complete if Known</i>			
				Application Number		To Be Assigned	
				Filing Date		Concurrently Herewith	
				First Named Inventor		Steven Francis LeBeouf	
				Art Unit			
				Examiner Name			
Sheet	<b>A2</b>	of	<b>A2</b>	Attorney Docket Number	9653-7TSCT2		

	30	JP 2000-116611	04-25-2000	KOWA SPINNING CO LTD; KOWA CO		
	31	JP 9-299342	11-25-1997	IKYO KK		
	32	JP 9-253062	09-30-1997	IKYO KK		
	33	JP 7-241279	09-19-1995	NIPPON KODEN CORP		

NON PATENT LITERATURE DOCUMENTS			
Examiner Initials*	Cite No.	Include name of the author (in CAPITAL LETTERS), title of the article (when appropriate), title of the item (book, magazine, journal, serial, symposium, catalog, etc.), date, page(s), volume-issue number(s), publisher, city and/or country where published	T
	34	FITRAINER "The Only Trainer You Need"; <a href="http://itami.com">http://itami.com</a> ; Downloaded 2/26/2010; ©2008 FITriainer™; 2 pages	

ALL REFERENCES CONSIDERED EXCEPT WHERE LINED THROUGH. /RF/

Examiner Signature	/Rodney Fuller/	Date Considered	05/18/2014
--------------------	-----------------	-----------------	------------

\*EXAMINER: Initial if reference considered, whether or not citation is in conformance with MPEP 609. Draw line through citation if not in conformance and not considered. Include copy of this form with next communication to applicant.

<b>Search Notes</b>  	<b>Application/Control No.</b>  14184396	<b>Applicant(s)/Patent Under Reexamination</b>  LEBOEUF ET AL.
	<b>Examiner</b>  RODNEY FULLER	<b>Art Unit</b>  2852

CPC- SEARCHED		
Symbol	Date	Examiner

CPC COMBINATION SETS - SEARCHED		
Symbol	Date	Examiner

US CLASSIFICATION SEARCHED			
Class	Subclass	Date	Examiner
600	310	5/30/2014	/RF/

SEARCH NOTES		
Search Notes	Date	Examiner
East text search history printout	5/30/2014	/RF/

INTERFERENCE SEARCH			
US Class/ CPC Symbol	US Subclass / CPC Group	Date	Examiner

	/RODNEY FULLER/ Primary Examiner.Art Unit 2852
--	---



UNITED STATES PATENT AND TRADEMARK OFFICE

UNITED STATES DEPARTMENT OF COMMERCE  
 United States Patent and Trademark Office  
 Address: COMMISSIONER FOR PATENTS  
 P.O. Box 1450  
 Alexandria, Virginia 22313-1450  
 www.uspto.gov

BIB DATA SHEET

CONFIRMATION NO. 8272

<b>SERIAL NUMBER</b> 14/184,396	<b>FILING or 371(c) DATE</b> 02/19/2014 <b>RULE</b>	<b>CLASS</b> 600	<b>GROUP ART UNIT</b> 2852	<b>ATTORNEY DOCKET NO.</b> 9653-7TSCT2	
<b>APPLICANTS</b> Valencell, Inc., Raleigh, NC, Assignee (with 37 CFR 1.172 Interest); <b>INVENTORS</b> Steven Francis LeBoeuf, Raleigh, NC; Jesse Berkley Tucker, Knightdale, NC; Michael Edward Aumer, Raleigh, NC; <b>** CONTINUING DATA *****</b> This application is a CON of 12/691,388 01/21/2010 PAT 8700111 which claims benefit of 61/208,567 02/25/2009 and claims benefit of 61/208,574 02/25/2009 and claims benefit of 61/212,444 04/13/2009 and claims benefit of 61/274,191 08/14/2009 <b>** FOREIGN APPLICATIONS *****</b> <b>** IF REQUIRED, FOREIGN FILING LICENSE GRANTED **</b> 03/07/2014					
Foreign Priority claimed <input type="checkbox"/> Yes <input checked="" type="checkbox"/> No 35 USC 119(a-d) conditions met <input type="checkbox"/> Yes <input checked="" type="checkbox"/> No Verified and /RODNEY EVAN FULLER/ Acknowledged Examiner's Signature	<input type="checkbox"/> Met after Allowance Initials	<b>STATE OR COUNTRY</b> NC	<b>SHEETS DRAWINGS</b> 21	<b>TOTAL CLAIMS</b> 24	<b>INDEPENDENT CLAIMS</b> 2
<b>ADDRESS</b> MYERS BIGEL SIBLEY & SAJOVEC PO BOX 37428 RALEIGH, NC 27627 UNITED STATES					
<b>TITLE</b> METHODS AND APPARATUS FOR GENERATING DATA OUTPUT CONTAINING PHYSIOLOGICAL AND MOTION-RELATED INFORMATION					
<b>FILING FEE RECEIVED</b> 2060	FEES: Authority has been given in Paper No. _____ to charge/credit DEPOSIT ACCOUNT No. _____ for following:		<input type="checkbox"/> All Fees <input type="checkbox"/> 1.16 Fees (Filing) <input type="checkbox"/> 1.17 Fees (Processing Ext. of time) <input type="checkbox"/> 1.18 Fees (Issue) <input type="checkbox"/> Other _____ <input type="checkbox"/> Credit		



UNITED STATES PATENT AND TRADEMARK OFFICE

UNITED STATES DEPARTMENT OF COMMERCE
United States Patent and Trademark Office
Address: COMMISSIONER FOR PATENTS
P.O. Box 1450
Alexandria, Virginia 22313-1450
www.uspto.gov

Table with 4 columns: APPLICATION NUMBER (14/184,396), FILING OR 371(C) DATE (02/19/2014), FIRST NAMED APPLICANT (Steven Francis LeBoeuf), ATTY. DOCKET NO./TITLE (9653-7TSCT2)

CONFIRMATION NO. 8272

PUBLICATION NOTICE

20792
MYERS BIGEL SIBLEY & SAJOVEC
PO BOX 37428
RALEIGH, NC 27627



Title:METHODS AND APPARATUS FOR GENERATING DATA OUTPUT CONTAINING PHYSIOLOGICAL AND MOTION-RELATED INFORMATION

Publication No.US-2014-0171755-A1

Publication Date:06/19/2014

NOTICE OF PUBLICATION OF APPLICATION

The above-identified application will be electronically published as a patent application publication pursuant to 37 CFR 1.211, et seq. The patent application publication number and publication date are set forth above.

The publication may be accessed through the USPTO's publically available Searchable Databases via the Internet at www.uspto.gov. The direct link to access the publication is currently http://www.uspto.gov/patft/.

The publication process established by the Office does not provide for mailing a copy of the publication to applicant. A copy of the publication may be obtained from the Office upon payment of the appropriate fee set forth in 37 CFR 1.19(a)(1). Orders for copies of patent application publications are handled by the USPTO's Office of Public Records. The Office of Public Records can be reached by telephone at (703) 308-9726 or (800) 972-6382, by facsimile at (703) 305-8759, by mail addressed to the United States Patent and Trademark Office, Office of Public Records, Alexandria, VA 22313-1450 or via the Internet.

In addition, information on the status of the application, including the mailing date of Office actions and the dates of receipt of correspondence filed in the Office, may also be accessed via the Internet through the Patent Electronic Business Center at www.uspto.gov using the public side of the Patent Application Information and Retrieval (PAIR) system. The direct link to access this status information is currently http://pair.uspto.gov/. Prior to publication, such status information is confidential and may only be obtained by applicant using the private side of PAIR.

Further assistance in electronically accessing the publication, or about PAIR, is available by calling the Patent Electronic Business Center at 1-866-217-9197.

Office of Data Management, Application Assistance Unit (571) 272-4000, or (571) 272-4200, or 1-888-786-0101



Attorney Docket No.: 9653-7TSCT2

**PATENT**

**IN THE UNITED STATES PATENT AND TRADEMARK OFFICE**

In re: LeBoeuf et al.

Confirmation No.: 8272

Serial No.: 14/184,396

Group Art Unit: 2852

Filed: February 19, 2014

Examiner: Rodney Evan Fuller

For: **METHODS AND APPARATUS FOR GENERATING DATA OUTPUT  
CONTAINING PHYSIOLOGICAL AND MOTION-RELATED INFORMATION**

Date: August 26, 2014

Mail Stop Amendment  
Commissioner for Patents  
P. O. Box 1450  
Alexandria, VA 22313-1450

**RESPONSE TO OFFICE ACTION OF JUNE 3, 2014**

Applicants provide the present Response to address the issues raised in the Office Action (the "Action") mailed June 3, 2014. Applicants provide the present Response pursuant to the rules stated in revised 37 C.F.R. 1.121 that became effective on July 30, 2003.

It is not believed that an extension of time and/or additional fee(s)-including fees for net addition of claims-are required, beyond those that may otherwise be provided for in documents accompanying this paper. In the event, however, that an extension of time is necessary to allow consideration of this paper, such an extension is hereby petitioned under 37 C.F.R. §1.136(a). Any additional fees believed to be due in connection with this paper may be charged to our Deposit Account No. 50-0220.

**Amendments** to the Specification begin on Page 2 of this paper.

**Amendments** to the claims begin on Page 3 of this paper.

**Remarks** begin on Page 7 of this paper.

In re: LeBoeuf et al.  
Serial No. 14/184,396  
Filed: February 19, 2014  
Page 2

**In the Specification:**

On page 1, line 1, please amend the RELATED APPLICATIONS section as follows:

RELATED APPLICATIONS

This application is a continuation application of pending U.S. Patent Application Serial No. 12/691,388, filed January 21, 2010, now U.S. Patent No. 8,700,111, which claims the benefit of and priority to U.S. Provisional Patent Application No. 61/208,567 filed 02/25/2009, U.S. Provisional Patent Application No. 61/208,574 filed 02/25/2009, U.S. Provisional Patent Application No. 61/212,444 filed 4/13/2009, and U.S. Provisional Patent Application No. 61/274,191 filed 8/14/2009, the disclosures of which are incorporated herein by reference as if set forth in their entireties.

Please amend the paragraph beginning on page 5, line 1 of the specification as follows:

-- In some embodiments, an earbud includes at least one lens in optical communication with the light transmissive material. Each lens may be configured to focus light from the optical emitter onto one or more predetermined locations in the ear of a subject and/or to focus collected external light onto the optical detector, --

Please amend the paragraph beginning on page 10, line 21 of the specification as follows:

-- Fig. 6 is a side section view of a light-guiding earbud for a headset, according to some embodiments of the present invention. [[.]] --

This listing of claims replaces all prior versions in the application.

**Listing of Claims:**

1. (Currently Amended) A method of generating data output containing physiological and motion-related information, the method comprising:

sensing physical activity and physiological information from ~~of~~ a subject via a single monitoring device at least one motion sensor attached to the subject, wherein the monitoring device comprises at least one motion sensor for sensing the physical activity and at least one photoplethysmography (PPG) sensor for sensing the physiological information; and

~~sensing physiological information from the subject via at least one photoplethysmography (PPG) sensor attached to the subject; and~~

processing signals from the at least one motion sensor and signals from the at least one PPG sensor via a processor of the monitoring device into a serial data output of physiological information and motion-related information, wherein the serial data output is configured such that a plurality of subject physiological parameters comprising subject heart rate and subject respiration rate can be extracted from the physiological information[[,]] and such that ~~wherein~~ a plurality of subject physical activity parameters can be extracted from the motion-related information.

2. (Cancelled)

3. (Currently Amended) The method of Claim 1, wherein the plurality of subject physiological parameters that can be extracted from the physiological information further includes one or more ~~comprise at least two~~ of the following: blood flow, blood pulse volume, ~~heart rate~~, blood analyte levels, breathing ~~rate or~~ volume, blood oxygen levels, blood pressure,  $VO_{2max}$ , the 1st derivative of at least one blood pulse, and the 2nd derivative of at least one blood pulse.

4. (Previously Presented) The method of Claim 1, wherein the serial data output is parsed out such that an application-specific interface (API) can utilize the physiological information and motion-related information for an application.

5. (Original) The method of Claim 1, wherein the application is configured to generate statistical relationships between subject physiological parameters and subject physical activity parameters in the physiological information and motion-related information.

6. (Original) The method of Claim 5, wherein the application is configured to generate statistical relationships between subject physiological parameters and subject physical activity parameters via at least one of the following: principal component analysis, multiple linear regression, machine learning, and Bland-Altman plots.

7. (Currently Amended) The method of Claim 1, further comprising, ~~filtering subject motion noise from the signals from the at least one PPG sensor~~ prior to processing signals from the at least one motion sensor and signals from the at least one PPG sensor into the serial data output, removing frequency bands from the PPG signals that are outside of a range of interest using at least one band-pass filter to produce pre-conditioned PPG signals, and filtering the pre-conditioned PPG signals to reduce motion artifacts and noise artifacts from the pre-conditioned PPG signals to produce cleaner physiological information.

8. (Original) The method of Claim 7, wherein the subject motion noise comprises subject footstep noise.

9. (Currently Amended) The method of Claim 7, wherein ~~filtering subject motion noise from the preconditioned PPG signals from the at least one PPG sensor~~ comprises at least one of the following: FIR (Finite Impulse Response) filtering, IIR (Infinite Impulse Response) filtering, adaptive filtering, phase filtering, and frequency filtering.

10. (Original) The method of Claim 1, wherein the at least one motion sensor comprises at least one of the following: an optical sensor, an inertial sensor, an electrically conductive sensor, a capacitive sensor, an inductive sensor, an accelerometer, and a blocked channel sensor.

11. (Original) The method of Claim 1, wherein the at least one PPG sensor comprises at least one optical emitter, at least one optical detector, and at least one light guide.

12. (Original) The method of Claim 1, wherein the at least one motion sensor and the at least one PPG sensor are integrated into a wearable device.

13. (Original) The method of Claim 12, wherein the wearable device is configured to be attached to the subject at one or more of the following body locations: an ear, a limb, the nose, and a digit.

14. (Original) The method of Claim 1 wherein the physiological information and/or motion-related information comprises information on data integrity.

15. (Currently Amended) A wearable device, comprising:  
a housing; and

a chipset enclosed within the housing, the chipset comprising at least one PPG sensor, at least one motion sensor, and at least one signal processor configured to process signals from the at least one motion sensor and signals from the at least one PPG sensor to reduce motion artifacts from the PPG signals;

wherein the housing comprises at least one window that optically exposes the at least one PPG sensor to a body of a subject wearing the device, and wherein the housing comprises non-air light transmissive material in optical communication with the at least one PPG sensor and the window.

16. (Currently Amended) The device of Claim 15, wherein the non-air light transmissive material comprises ~~further comprising~~ at least one light guide in optical communication with the at least one PPG sensor and the window.

17. (Original) The device of Claim 15, wherein the wearable device is an earbud.

18. (Original) The device of Claim 15, wherein the wearable device is a headset.

19-20. (Cancelled)

21. (Currently Amended) The device of Claim 15 [[19]], wherein the at least one processor is configured to reduce motion artifacts by removing filter subject motion noise from the signals from the at least one PPG sensor prior to processing signals from the at least one motion sensor and signals from the at least one PPG sensor into the serial data output frequency bands from the signals that are outside of a range of interest using at least one band-pass filter to produce pre-conditioned signals.

22. (Currently Amended) The device of Claim 15 [[21]], wherein the subject motion artifacts noise comprises subject footstep-related motion artifacts noise.

23. (Currently Amended) The device of Claim 21, wherein the at least one processor is configured to filter subject motion noise from the preconditioned signals from the at least one PPG sensor via at least one of the following: FIR (Finite Impulse Response) filtering, IIR (Infinite Impulse Response) filtering, adaptive filtering, phase filtering, and frequency filtering.

24. (Original) The device of Claim 15, wherein the at least one motion sensor comprises at least one of the following: an optical sensor, an inertial sensor, an electrically conductive sensor, a capacitive sensor, an inductive sensor, an accelerometer, and a blocked channel sensor.

**REMARKS**

After the above amendments, Claims 1, 3-18 and 21-24 are pending.

The disclosure is objected to because of informalities

Claims 1-24 stand provisionally rejected on the grounds of nonstatutory double patenting as being unpatentable over Claims 1-20 of copending Application No. 14/194,891.

Claims 1-24 stand rejected on the grounds of nonstatutory double patenting as being unpatentable over Claims 1-42 of U.S. Patent No. 8,700,111.

Claims 2 and 20 stand rejected under 35 U.S.C. §112, first paragraph, as failing to comply with the enablement requirement.

Claims 1-14 stand rejected under 35 U.S.C. §102(3) as being anticipated by U.S. Patent Application Publication No. 2009/0287067 to Dorogusker et al. ("Dorogusker").

Claims 15-24 stand rejected under 35 U.S.C. §103(a) as being unpatentable over Dorogusker in view of U.S. Patent Application Publication No. 2008/0177162 to Bae et al. ("Bae").

Applicants have amended Claims 1, 3, 7, 9, 15, 16 and 21-23, as indicated above, for clarification. Claims 2, 19 and 20 have been cancelled without prejudice or disclaimer. Applicants respectfully traverse the double patenting rejections and the rejections under §112, §102, and §103 for at least the reasons described herein.

**Telephonic Interview**

Applicants appreciate the Examiner's courtesy and professionalism in discussing the Action during a telephone interview on June 18, 2014. The present Remarks will document patentability of the claims and will also provide an interview summary for this interview.

During the telephone interview, a draft set of amended claims, submitted to the Examiner prior to the telephone interview, was discussed relative to the Dorogusker and Bae references.

The above constitutes a complete summary of the telephone interview with the Examiner on June 18, 2014.

### **Specification Objections**

The specification is objected to because the status of Patent Application No. 12/691,388 does not include the issued patent status. Applicants have amended the specification as indicated above to include the issued patent status. As such, the objection to the specification is overcome.

In addition, Applicants have amended the Specification, as indicated above, to correct several typographical errors.

### **Section 112 Rejections**

Claims 2 and 20 stand rejected under 35 U.S.C. §112, first paragraph, as failing to comply with the enablement requirement. Applicants have cancelled Claims 2 and 20 without prejudice or disclaimer. As such, the rejection of Claims 2 and 20 are rendered moot.

### **Double Patenting Rejections Overcome**

Claims 1-24 stand provisionally rejected on the grounds of nonstatutory double patenting as being unpatentable over Claims 1-20 of copending Application No. 14/194,891. Claims 1-24 stand rejected on the grounds of nonstatutory double patenting as being unpatentable over Claims 1-42 of U.S. Patent No. 8,700,111. In order to advance the present application to allowance, a Terminal Disclaimer is being filed concurrently to overcome the non-statutory obviousness-type double patenting rejection based on co-pending U.S. Patent Application No. 14/194,891, and U.S. Patent No. 8,700,111. The filing of this Terminal Disclaimer shall not be construed as an admission that the claims are unpatentable under the judicially created doctrine of obviousness-type double patenting or are obvious under 35 USC §103.

### **Section 102 Rejections**

Claims 1-14 stand rejected under 35 U.S.C. §102(3) as being anticipated by Dorogusker. Applicants respectfully traverse the rejection because Dorogusker does not teach or suggest all of the recitations of amended independent Claim 1. For example, amended independent Claim 1 recites a method of generating data output containing physiological and motion-related information, the method comprising:



sensing physical activity and physiological information from a subject via a single monitoring device attached to the subject, wherein the monitoring device comprises at least one motion sensor for sensing the physical activity and at least one photoplethysmography (PPG) sensor for sensing the physiological information; and processing signals from the at least one motion sensor and signals from the at least one PPG sensor via a processor of the monitoring device into a serial data output of physiological information and motion-related information, wherein the serial data output is configured such that a plurality of subject physiological parameters comprising subject heart rate and subject respiration rate can be extracted from the physiological information and such that a plurality of subject physical activity parameters can be extracted from the motion-related information.

Dorogusker describes systems and methods for integrating sensors for tracking a user's performance metrics into media devices and accessories therefore. (Dorogusker, ¶ 0032.) The first embodiment illustrated in Fig. 2 of Dorogusker includes sensors 218 which can include one or more infrared photodetectors for tracking a user's temperature, heat flux, and heart rate. (Dorogusker, ¶ 0034.) From infrared radiation in the user's ear, the sensors 218 can detect minute temperature variations due to the user's heart beats and heart rate can be calculated based on the time between beats and the user's temperature can be set as the "DC component" (or average or median value) of the detected temperature distribution. (Dorogusker, ¶ 0034.)

The second embodiment illustrated in Figs. 3A-3B of Dorogusker includes a light source 312 and photodetector 314 that can be used to track a user's blood oxygen content and heart-rate. (Dorogusker, ¶ 0039.) Electrical contacts also can be disposed within clip portion 308a and/or 308b, in addition to or instead of light source 312 and photodetector 314. (Dorogusker, ¶ 0041.) These electrical contacts can include contacts for detecting, e.g., temperature, heat flux, EKG waveforms, heart rate, any other suitable physiological metric, or any combination thereof. (Dorogusker, ¶ 0041.) However, Dorogusker is wholly silent as to being able to extract subject heart rate *and* subject respiration rate from any of the data generated by the various sensors. The statement "any other suitable physiological metric" is not sufficient, by itself, to teach or suggest being able to extract both heart rate and respiration rate.

The third embodiment illustrated in Fig. 4 of Dorogusker includes a headset 402 having sensors 410 and a portable electronic device 412 having sensors 424. (Dorogusker, ¶¶ 0042, 0044, Fig. 4.) The sensors 410 can include electrical contacts for measuring heart rate

or sensors for a reflectance pulse oximeter. (Dorogusker, ¶ 0042.) The sensors 424 can be sensors that track a user's performance metrics or a user's movements. (Dorogusker, ¶ 0051.) Dorogusker describes interleaving control signals and sensor data with other signals using a serial interface protocol. (Dorogusker, ¶ 0052.) However, Applicants respectfully submit that interleaving control signals and sensor data with other signals does not teach or suggest a serial data output of physiological information and motion-related information configured such that physiological parameters can be extracted from the physiological information and such that physical activity parameters can be extracted from the motion-related information.

In view of the above, Dorogusker fails to teach or suggest "processing signals from the at least one motion sensor and signals from the at least one PPG sensor via a processor of the monitoring device into a serial data output of physiological information and motion-related information, wherein a plurality of subject physiological parameters comprising subject heart rate and subject respiration rate can be extracted from the physiological information, and wherein a plurality of subject physical activity parameters can be extracted from the motion-related information," as recited in Claim 1. Because Dorogusker fails to teach or suggest all of the recitations of Claim 1, Claim 1 is not anticipated by Dorogusker and the rejection of independent Claim 1 under 35 U.S.C. §102 is overcome. Additionally, dependent Claims 3-14 are patentable at least by virtue of the patentability of independent Claim 1, from which they depend.

### **Section 103 Rejections**

Claims 15-24 stand rejected under 35 U.S.C. §103(a) as being unpatentable over Dorogusker in view of Bae. Applicants respectfully traverse the rejections because Dorogusker and Bae, alone or in combination, fail to teach or suggest all of the recitations of amended independent Claim 15. For example, amended independent Claim 15 recites a wearable device, comprising:

- a housing; and
- a chipset enclosed within the housing, the chipset comprising at least one PPG sensor, at least one motion sensor, and at least one signal processor configured to process signals from the at least one motion sensor and signals from the at least one PPG sensor to reduce motion artifacts from the PPG signals;
- wherein the housing comprises at least one window that optically exposes the at least one PPG sensor to a body of a subject wearing the device, and *wherein the housing comprises non-air light transmissive material in optical communication with the at least one PPG sensor and the window.*

Dorogusker is wholly silent as to the use of non-air light transmissive material in the disclosed sensor devices. For example, Dorogusker does not teach or suggest the use of non-air light transmissive material between the sensors 218 and the acoustical aperture 212 in the earbud illustrated in Fig. 2. In fact, one skilled in the art would not be motivated to utilize non-air light transmissive material between the sensors 218 and the acoustical aperture 212 as this would impede sound from the speaker 210. Dorogusker also fails to teach or suggest the use of non-air light transmissive material in either of the other illustrated embodiments.

The secondary reference, Bae, fails to rectify the deficiencies of Dorogusker with respect to Claim 15. Bae is only cited for disclosing a processor located inside a housing. (Action, page 9.) Bae describes a biosignal measurement apparatus including: a headset; a member being detachable from the headset, and being attached onto an ear of a user; a PPG sensor being attached onto the member to detect a PPG signal from the ear of the user; and an acceleration sensor being attached onto the member to detect an acceleration signal due to a motion of the user. (Bae, Abstract.) Fig. 1 from Bae'162 is set forth below.

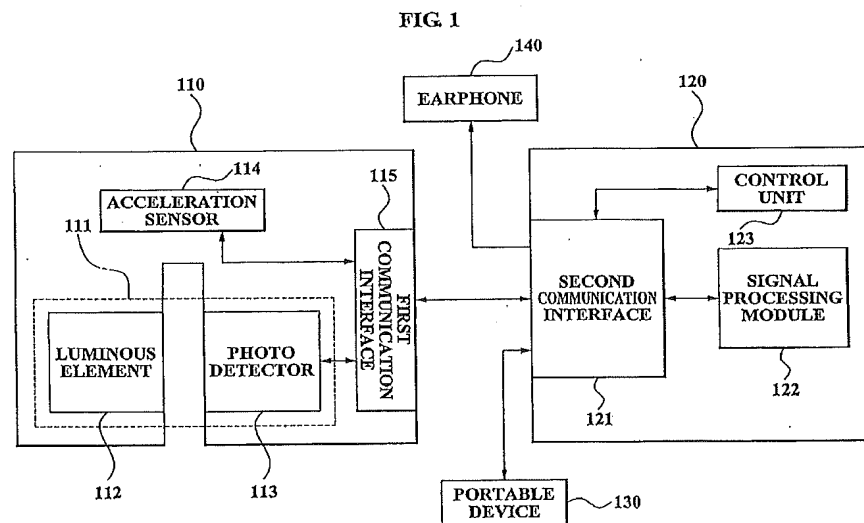

The illustrated member 110 has a photoplethysmography (PPG) sensor 111 that includes a luminous element 112 and a photo detector 113. (Bae, ¶¶0036-0037.) The member 110 may be formed in a shape of tongs such that the luminous element 112 and the photo detector 113 may be provided on inner surfaces of the tongs respectively such that, when the member 110 is clipped onto the ear of the user, the luminous element 112 and the photo detector 113 may be attached onto both sides of the ear of the user. (Bae, ¶0037.)

Bae is wholly silent as to light transmissive material in optical communication with either the luminous element 112 or the photo detector 113 and that is configured to deliver

light from the luminous element 112 or collect light external to the member 110 and deliver collected light to the photo detector 113. As such, Bae fails to teach or suggest "wherein the housing comprises at least one window that optically exposes the at least one PPG sensor to a body of a subject wearing the device, and wherein the housing comprises non-air light transmissive material in optical communication with the at least one PPG sensor and the window," as recited in Claim 15.

Thus, Bae fails to rectify the deficiencies of Dorogusker with respect to independent Claim 15. As such, Claim 15 is patentable and the rejection of Claim 15 under §103 is overcome. Additionally, dependent Claims 16-18 and 21-24 are patentable at least by virtue of the patentability of independent Claim 15, from which they depend.

#### **Dependent Claims**

As each of the dependent claims depends from a base claim that is believed to be in condition for allowance, Applicants do not believe that it is necessary to argue the allowability of each dependent claim individually. Applicants do not necessarily concur with the interpretation of these claims, or with the bases for rejection set forth in the Action. Applicants therefore reserve the right to address the patentability of these claims individually as necessary in the future.

#### **Supplemental Information Disclosure Statement**

Applicants are concurrently submitting a Supplemental Information Disclosure Statement (IDS) for the Examiner's consideration. Return of the initialed IDS is respectfully requested.

#### **CONCLUSION**

In view of the above, it is respectfully submitted that this application is in condition for allowance, which action is respectfully requested.

Respectfully submitted,



Needham J. Boddie, II  
Attorney for Applicants  
Registration No. 40,519

In re: LeBoeuf et al.  
Serial No. 14/184,396  
Filed: February 19, 2014  
Page 13

USPTO Customer No. 20792  
Myers Bigel Sibley & Sajovec, P.A.  
Post Office Box 37428  
Raleigh, North Carolina 27627  
Telephone: (919) 854-1400  
Facsimile: (919) 854-1401  
Doc. No. 1559443

**CERTIFICATION OF TRANSMISSION**

I hereby certify that this correspondence is being transmitted via the Office electronic filing system in accordance with 37 C.F.R. § 1.6(a)(4) to the U.S. Patent and Trademark Office on **August 26, 2014**.

  
Susan E. Freedman

IN THE UNITED STATES PATENT AND TRADEMARK OFFICE

In re: LeBoeuf et al.	Confirmation No.: 8272
Application No.: 14/184,396	Examiner: Rodney Evan Fuller
Filing Date: February 19, 2014	Group Art Unit: 2852
For: METHODS AND APPARATUS FOR GENERATING DATA OUTPUT CONTAINING PHYSIOLOGICAL AND MOTION-RELATED INFORMATION	

August 26, 2014

Mail Stop AMENDMENT  
Commissioner for Patents  
Box 1450  
Alexandria, VA 22313-1450

**INFORMATION DISCLOSURE STATEMENT TRANSMITTAL**

Sir:

Attached is an Information Disclosure Statement listing of documents, together with a copy of any listed foreign patent document and/or non-patent literature. A copy of any listed U.S. patent and/or U.S. patent application publication is not provided herewith in accordance with 37 C.F.R. § 1.98(a)(2)(ii).

- In accordance with **37 CFR 1.97(b)**, the information disclosure statement is being filed:
  - (1) within three months of the filing date of a national application other than a continued prosecution application under §1.53(d);
  - (2) within three months of the date of entry of the national stage as set forth in §1.491 in an international application;
  - (3) before the mailing of a first Office Action on the merits; or
  - (4) before the mailing of a first Office Action after the filing of a request for continued examination under §1.114.

In accordance with **37 CFR 1.97(c)**, the information disclosure statement is being filed after the period specified in 37 CFR 1.97(b) above, but before the mailing date of any of a final action under §1.113, a notice of allowance under §1.311, or an action that otherwise closes prosecution in the application, and is accompanied by one of the following:

- (1) The statement specified under **37 CFR 1.97(e)**, as follows:
  - Each item of information contained in the information disclosure statement was first cited in any communication from a foreign patent office in a counterpart foreign application not more than three months prior to the filing of the information disclosure statement; or
  - No item of information contained in the information disclosure statement was cited in a communication from a foreign patent office in a counterpart foreign application, and, to the knowledge of the person signing the certification after making reasonable inquiry, no item of information contained in the information disclosure statement was known to any individual designated in §1.56(c) more than three months prior to the filing of the information disclosure statement; or
- (2) The fee set forth in §1.17(p);

In accordance with **37 CFR 1.97(d)**, the information disclosure statement is being filed after the period specified in 37 CFR 1.97(c) above, but on or before payment of the issue fee, and is accompanied by **both** of the following:

(1) The statement specified under **37 CFR 1.97(e)**, as follows:

That each item of information contained in the information disclosure statement was first cited in any communication from a foreign patent office in a counterpart foreign application not more than three months prior to the filing of the information disclosure statement; **or**

That no item of information contained in the information disclosure statement was cited in a communication from a foreign patent office in a counterpart foreign application, and, to the knowledge of the person signing the certification after making reasonable inquiry, no item of information contained in the information disclosure statement was known to any individual designated in §1.56(c) more than three months prior to the filing of the information disclosure statement; **and**

(2) The fee set forth in §1.17(p);

In accordance with **37 CFR 1.97(g)**, the information disclosure statement shall not be construed as a representation that a search has been made.

In accordance with **37 CFR 1.97(h)**, the information disclosure statement shall not be construed to be an admission that the information cited in the statement is, or is considered to be, material to patentability as defined in §1.56(b).

The Director is hereby authorized to charge the fee specified in 37 C.F.R. § 1.17(p), and any fee deficiency or credit any overpayment, to Deposit Account No. 50-0220; **or**

No fee is believed due. However, the Director is hereby authorized to charge any deficiency or credit any overpayment to Deposit Account No. 50-0220.

Respectfully submitted,



Needham J. Boddie, II  
Registration No. 40,519  
Attorney for Applicant

**Customer Number 20792**

Myers Bigel Sibley & Sajovec, P.A.  
P.O. Box 37428, Raleigh, NC 27627  
919-854-1400  
919-854-1401 (Fax)

**CERTIFICATION OF TRANSMISSION**

I hereby certify that this correspondence is being transmitted via the Office electronic filing system in accordance with 37 CFR § 1.6(a)(4) to the U.S. Patent and Trademark Office on August 26, 2014.

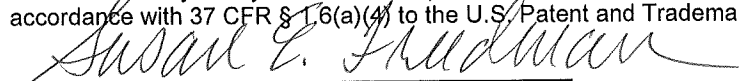

Susan E. Freedman

<b>INFORMATION DISCLOSURE STATEMENT BY APPLICANT</b>  <i>(use as many sheets as necessary)</i>				<i>Complete if Known</i>	
				Application Number	14/184,396
				Filing Date	02-19-2014
				First Named Inventor	Steven Francis LeBoeuf
				Art Unit	2852
				Examiner Name	Rodney Evan Fuller
Sheet	<b>E1</b>	of	<b>E1</b>	Attorney Docket Number	9653-7TSCT2

U.S. PATENT DOCUMENTS					
Examiner Initials*	Cite No.	Document Number	Publication Date MM-DD-YYYY	Name of Patentee or Applicant of Cited Document	Pages, Columns, Lines, Where Relevant Passages or Relevant Figures Appear
		Number-Kind Code (if known)			
	1.	US- 2012/0179011 A1	07-12-2012	Moon et al.	
	2.	US- 7,107,088 B2	09-12-2006	Aceti	
	3.	US- 2003/0109030 A1	06-12-2003	Uchida et al.	
	4.	US- 6,358,216 B1	03-19-2002	Kraus et al.	
		US-			
		US-			
		US-			
		US-			
		US-			
		US-			
		US-			
		US-			
		US-			

FOREIGN PATENT DOCUMENTS						
Examiner Initials*	Cite No.	Foreign Patent Document	Publication Date MM-DD-YYYY	Name of Patentee or Applicant of Cited Document	Pages, Columns, Lines, Where Relevant Passages or Relevant Figures Appear	T
		Country Code, Number, Kind Code (if known)				
	5.	EP 2 077 091 A2	07-08-2009	Perception Digital Limited		

NON PATENT LITERATURE DOCUMENTS			
Examiner Initials*	Cite No.	Include name of the author (in CAPITAL LETTERS), title of the article (when appropriate), title of the item (book, magazine, journal, serial, symposium, catalog, etc.), date, page(s), volume-issue number(s), publisher, city and/or country where published	T

Examiner Signature		Date Considered	
--------------------	--	-----------------	--

\*EXAMINER: Initial if reference considered, whether or not citation is in conformance with MPEP 609. Draw line through citation if not in conformance and not considered. Include copy of this form with next communication to applicant.



(19)

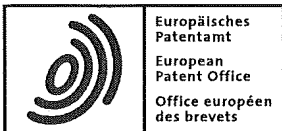

(11)

**EP 2 077 091 A2**

(12)

**EUROPEAN PATENT APPLICATION**

(43) Date of publication:  
**08.07.2009 Bulletin 2009/28**

(51) Int Cl.:  
**A61B 5/024 (2006.01)**

(21) Application number: **09250024.8**

(22) Date of filing: **06.01.2009**

(84) Designated Contracting States:  
**AT BE BG CH CY CZ DE DK EE ES FI FR GB GR  
 HR HU IE IS IT LI LT LU LV MC MK MT NL NO PL  
 PT RO SE SI SK TR**  
 Designated Extension States:  
**AL BA RS**

- Chan, Kai Kin  
Hong Kong SAR (HK)
- Wong, Ming Yip  
Hong Kong SAR (HK)
- Yeung, Kai Wai  
Hong Kong SAR (HK)
- Chau, Fo  
Hong Kong SAR (HK)

(30) Priority: **07.01.2008 US 6321 P**  
**21.08.2008 US 195502**

(71) Applicant: **Perception Digital Limited**  
**Hong Kong SAR (HK)**

(74) Representative: **Martin, David John et al**  
**Marks & Clerk LLP**  
**5th Floor**  
**14 South Parade**  
**Leeds**  
**LS1 5QS (GB)**

(72) Inventors:  
• **Ma, Chor Tin**  
**Hong Kong SAR (HK)**

**(54) Exercise device, sensor and method of determining body parameters during exercise**

(57) A noninvasive light sensor for detecting heart beat signals has a circular support member engageable circumferentially with a body part of a person. There are a plurality of light emitters and light detectors located in

pairs symmetrically about a circumference of the circular support member for respectively emitting light signals into different areas of tissue surrounding the body part, and receiving reflected light signals from the different areas of tissue surrounding the body part.

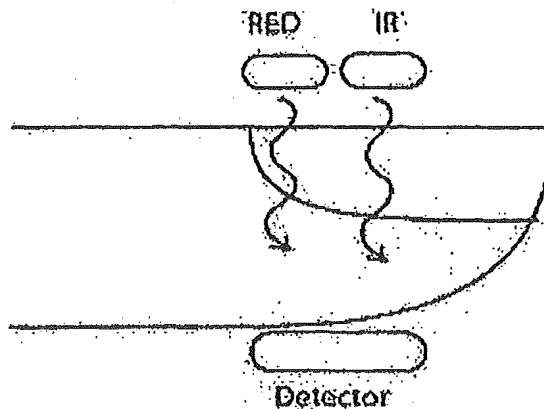

**Figure 1 (Prior Art)**

**EP 2 077 091 A2**

**Description**Field of the Invention

5 [0001] The current invention relates to an exercise device for monitoring body parameters of a wearer during exercise. The invention also relates to sensor for determining sensor signals from which body parameters can be derived and to a method of determining body parameters during exercise.

Background to the Invention

10 [0002] To achieve fitness goals it is necessary to exercise in the right intensity. Heart rate is one of the most accurate measurements of the intensity or exertion level of an exercise workout. The fitness of the heart is the key to aerobic endurance. Aerobic endurance is extremely important for both general fitness training and professional athletes. Heart monitors are one of the most effective aids for tracking and developing the progress on the path to increased aerobic endurance. For example, to loss weight and bum fat, it is desirable to exercise at 60-70% of one's maximum heart rate. To improve cardiovascular fitness, it is more suitable to exercise at 70-80% of one's maximum heart rate. Exercise at the wrong intensity will just waste the effort or may even harm the body.

15 [0003] Heart rate can easily be checked by checking the pulses at the wrist manually for, say, 15 seconds during exercise and calculate beats per minute. However, stopping during exercise to count pulse is not only inconvenient, but also disrupts both the workout and the heart rate. This method also introduces pressure to the carotid artery which slows down the pulse. Electronic heart monitors are an effective way to track and record heart rate over the course of an entire workout. They not only provide a complete record of the heart rate for the duration of your workout, but they are also more accurate than manual methods, and can provide other information such as body temperature, SpO2 (Oxyhemoglobin saturation by pulse oximetry) are also important information to determine condition of the body.

20 [0004] For professional athletes, cardiovascular fitness is the most significant factor in speed. Measuring the work-rate of the heart is one of the most accurate methods of determining how much benefit an athlete derives from a workout. A heart rate monitor can also help to avoid stressing the body too much. They are a useful tool for maximize the efficiency of the training while minimizing the opportunity for injury. Heart rate monitors also enable professional athletes to exercise below a certain ceiling, i.e. avoid depleting the body's glycogen stores and ensuring that the body has the energy to perform intense workouts with vigor. For general fitness training, a heart rate monitor can function as a coach guiding the user when he or she can handle more and work harder.

25 [0005] Most popular heart rate monitors use ECG type chest belt with a wireless link to sports watch. The heartbeat is detected by sensing the ECG signal from the chest belt and a pulse is sent to the sports watch via wireless connection. This type of heart rate monitor is accurate and reliable, but has the disadvantage that it is not comfortable for the user to wear a plastic belt on the chest during exercise. The belt will also become very dirty after use. Another method of detecting heartbeat is to use IR LED and IR sensor through the ear lobe or finger tip. This type of detector has the intrinsic problem of motion artifact and they are simply not reliable during exercise.

30 [0006] There are many devices that can measure body parameters of a person. For example, by using an infrared ear thermometer, clinical thermometer, the user could get his body temperature and by using pulse oximeter the user could get his heartbeat and the amount of oxygen attached to the hemoglobin. However, none of these devices is suitable for continuous monitoring of the body parameter when the user is doing exercise. The thermometer, for example, is not suitable for use in motion. For finger pulse oximeter, study suggested the motion will result in blood volume changes that invalidate its measurement [ref - "Motion Artifact in Pulse Oximetry", M.R. Neuman and N. Wang, Annual International Conference of the IEEE Engineering in Medicine and Biology Society, Vol. 12 No. 5, 1990].

35 [0007] Figure 1 is a schematic illustration is a typical finger type pulse oximeter implementation. Measuring heartbeat rate and SpO2 (blood oxygenation) is based on the absorption of red and infrared light. The technology is very sensitive to motion and hence is generally not suitable for use in personal exercise monitors. A few mechanical designs attempt to improve motion tolerance and enable the measurement to be used later in signal processing such that the heart rate in addition to SpO2 can be derived when the wearer is in motion. The device comprises two light sources, typically using LEDs of known wavelength. The wavelengths of the two light sources are 880 - 920nm (Infrared or IR) and 660nm (Red) respectively. To obtain heart rate (HR) only the IR light source is needed. To calculate blood oxygen levels (pulse oximetry) both the Red and the IR LED's would need to be used. In either case a photo detector is used to sense the light that has been transmitted or reflected into the skin or application sight. This transmission of light into an area of the body that is carrying blood and reflected back to the photo detector will be effected by the pulsatile flow caused by each heartbeat. This slight change in light intensity is detected and extracted to create a waveform commonly known as a plethysmograph. This waveform or the actual detection of the pulsatile flow can be converted into heart rate in the absent of motion. To calculate pulse oximetry the IR and the red light emissions are separately analyzed and then used in an empirical calculation to generate a predetermined blood oxygen level. The calibration and empirical calculation

can be found in many literatures.

[0008] Figure 2 shows an example of noise induced by motion in an IR LED and IR heartbeat/SpO<sub>2</sub> sensor. This noise signal may be of similar or even larger amplitude than the heartbeat signal and they are, in normal situation, in the same frequency band of the heartbeat signal (1-3 Hz). There is no easy method to extract the heartbeat signal from the mixture of the motion signal and heartbeat signal.

[0009] In addition to heart rate people are also interested in measuring the the distance run in an exercise session. There are many pedometer devices in the market that can count steps when a person walks or runs. These pedometers are fairly accurate and can record number of steps for a long period of time. Most of these devices require user to wear the device at particular orientation and position of the body trunk for the devices to work. These devices will usually fail if users are holding the device in hand when running or jogging.

### Summary of the Invention

[0010] Accordingly, is an object of the present invention to provide an exercise device for determining the body parameters of a wearer during exercise. This particular object of the present invention to provide a sensor and method of determining heartbeat from a sensor signal that overcome or at least ameliorates problems with known devices. It is a second object of the current invention to provide an exercise device the can detect steps and calculate distance run by a user.

[0011] According to a first aspect of the invention there is provided a noninvasive light sensor for detecting heart beat signals, comprising:

a circular support member engageable circumferentially with a body part of a person,  
 a plurality of light emitters located about a circumference of the circular support member for emitting light signals into different areas of tissue surrounding the body part, and  
 a plurality of light detectors located about a circumference of the circular support member for receiving reflected light signals from the different areas of tissue surrounding the body part.

[0012] Preferably, the light emitters and light detectors are located in pairs consisting of one of the emitters and one of the detectors.

[0013] Preferably, the light emitters comprises both red and infra-red light emitters.

[0014] Preferably, the plurality of light emitters consist of three light emitters located 120 degrees apart about the circumference of the support member.

[0015] Preferably, the plurality of light detectors consist of three light detectors located 120 degrees apart about the circumference of the support member.

[0016] Preferably, the light emitters and light detectors are located in pairs consisting of one of the emitters and one of the detectors.

[0017] Preferably, the support member is one of a ear bud insertable within an ear canal or a band locatable about a wrist or arm.

[0018] Preferably, the body part is an ear canal, the circular support member being an ear bud insertable with the an ear canal along an ear canal axis, wherein the plurality of light emitters are located about the periphery of the ear piece for emitting light signals perpendicular to the ear canal axis into the different areas of tissue surrounding the ear canal, and the plurality of light detectors are located about the periphery of the ear piece for receiving reflected light signals from the different areas of tissue surrounding the ear canal.

[0019] Preferably, the ear piece is resiliently deformable for expansion within the ear canal, such that the ear piece is firmly locatable within the ear canal.

[0020] Preferably, the ear price comprises an inner layer and an outer layer having a plurality of openings, the light emitters and light detectors located with the inner layer beneath the outer layer openings.

[0021] Preferably, the inner lay comprises foam and the outer layer comprises rubber.

[0022] Preferably, the ear piece has an outer surface for mating with the ear canal and a plurality of openings in the outer surface, the light emitters and light detectors located within the openings.

[0023] Preferably, the light emitters and light detectors are located below the outer surface of the ear piece.

[0024] Preferably, the openings have sides surrounding the light emitters and light detectors, the sides defining a narrow gap above the light emitters and light detectors.

[0025] Preferably, the sides of the openings are light absorbent.

[0026] Preferably, the noninvasive light sensor of further includes an audio speaker and/or a temperature sensor.

[0027] Preferably, the body part is a wrist or arm, the support member comprising a band locatable about a wrist or arm, the emitters and detectors located around an inner circumference of the band for respectively emitting light signals into the different areas of arm tissue and receiving reflected light from the different areas of arm tissue.

[0028] According to a second aspect of the invention there is provided a exercise device comprising:

5 a ear piece insertable with the an ear canal along an ear canal axis, a plurality of light emitters located about the periphery of the ear piece for emitting light signals perpendicular to the ear canal axis into different areas of tissue surrounding the ear canal, a plurality of light detectors located about the periphery of the ear piece for receiving reflected light signals from the different areas of tissue surrounding the ear canal, and a audio speaker,  
 an audio player for sending audio signals to the audio speaker,  
 a vital sign monitor that can determine at least one of heart rate, blood oxygen level or body temperature from signals of the emitters and detectors.

10 [0029] According to a third aspect of the invention there is provided a exercise system comprising:

an ear piece insertable within an ear canal along a canal axis, the ear piece having a plurality of light sensors and detectors, and a audio speaker,  
 15 a computer readable storage medium have space allocated for storage of audio files,  
 a vital sign monitor programmed to generating a vital sign signal from signals of the emitters and detectors, and  
 an audio player programmed to playback audio files thought the audio speaker in response to the vital sign signal and to vary attributes of the playback audio files in response to the vital sign signal.

20 [0030] Preferably, the attributes of the playback audio files to be varied are beat, tempo, tone and pitch.

[0031] Preferably, the audio player is programmed to vary the attributes by changing the playback audio files.

[0032] Preferably, the vital sign monitor is programmed to generating a heart rate, blood oxygen or temperature signal.

[0033] According to a fourth aspect of the invention there is provided a method of determining heart rate of a person during exercise comprising:

25 obtaining a plurality of sensor signals from multiple locations about a body part of a person, the sensor signals comprising a heart beat signals and a movement signals,  
 comparing the signals to separate the heart beat signals and a movement signals, and  
 determining heart rate from the heart beat signals.

30 [0034] Preferably, obtaining a plurality of sensor signals from locations comprises providing a plurality of heart beat sensors for positioning at multiple locations about the body part.

[0035] Preferably, comparing the signals to separate the heart beat signals and a movement signals comprises comparing the sensor signals to find in phase and out of phase components of the sensor signals.

35 [0036] Preferably, comparing the signals to separate the heart beat signals and a movement signals comprises finding a covariance between the sensor signals.

[0037] Preferably, determining heart rate from the heart beat signals comprises using match filters.

[0038] According to a fifth aspect of the invention there is provided a method in an exercise device of determining the steps taken by a person during exercise, comprising:

40 obtaining a plurality of sensor signals from symmetrical locations about a body part of a person, the sensor signals comprising a heart beat signals and a movement signals,  
 finding a dominant movement signal, and  
 determining zero crossing points of the dominant movement signal.

45 [0039] Preferably, finding a dominant movement signal comprises finding a movement signal having an amplitude greater than a threshold.

[0040] Preferably, finding a dominant movement signal comprises finding a sum of two sensor signals, finding a product of two times a third sensor signal, and subtracting the product from the sum.

50 [0041] Preferably, the third sensor signal has an amplitude lower than amplitudes of the two summed sensor signals.

[0042] Preferably, determining zero crossing points of the dominant movement signal comprises determining a number of the zero crossing points.

[0043] Preferably, method further comprises finding a product of a step-distance and the number of the zero crossing points and thereby finding a distance traveled by a person exercising.

55 [0044] Further aspects of the invention will become apparent from the following description.

Brief Description of the Drawings

[0045] An exemplary form of the present invention will now be described by way of example only and with reference to the accompanying drawings, in which:

- 5 Figure 1 is a schematic illustration of prior art operation of a heartbeat sensor/pulse oximeter,
- Figure 2 is a graphical illustration of the heartbeat signal with motion noise for a prior art earphone sensor,
- 10 Figure 3 is a schematic illustration of a first embodiment of a personal exercise device according to the invention having an earphone type sensor,
- Figure 4 is a schematic illustration of the earphone sensor arrangement for device of Figure 3,
- 15 Figure 5 is a perspective illustration of an ear bud of the earphone sensor,
- Figure 6 is a schematic illustration of a flexible printed circuit for locating and connection of sensors within the ear bud,
- Figure 7 is a perspective illustration of the ear bud without a rubber over-molding,
- 20 Figure 8 is a section illustration of the ear bud,
- Figure 9 is a perspective illustration of an alternative ear bud type earphone sensor and behind-the-ear parts of the alternative ear bud,
- 25 Figure 10 is a perspective illustration of a bud,
- Figure 11 is a schematic illustration of a second embodiment of a personal exercise device according to the invention having a arm band type sensor,
- 30 Figure 12 is a second schematic illustration of the personal exercise device having a arm band type sensor,
- Figure 13 is a schematic illustration of the sensor control and processing means of the exercise device,
- 35 Figure 14 illustrates decomposition of the noise vector into horizontal and vertical components, and
- Figure 15 is a schematic process block diagram of detector sensor signal processing used in the exercise device,
- 40 Figure 16 is a graphical illustration of the signal detected during exercise,
- Figure 17 is a block diagram of a method for detecting steps taken by a user during walking or running,
- Figure 18 is a graphical illustration of the relationship between distance and walking speed,
- 45 Figure 19 is a schematic block diagram of body parameter base playback control in the exercise device, and
- Figure 20 is a flow chart of the implementation of the body parameter based playback control.

Description of the Exemplary Embodiments

- 50 [0046] Aspects of the invention will now be illustrated as practiced in a first embodiment of a personal exercise device comprising an earphone sensor for listening to audio files and also for detecting body parameters; such as heartbeat, SpO2 and temperature; during exercise, a signal processing means for resolving sensor information into heartbeat and other body parameters and a workout assistance means for providing feedback of body parameters, exercise instructions and entertainment functions such as, but not limited to, music, video, game, e-book, photo, etc. However, this is not
- 55 intended to limit the scope of functionality or use of the invention. In a most basic embodiment of the invention the exercise device comprises simply an earpiece sensor and signal processing means for detecting heartbeat for feedback to the user or transmission to another device such as an exercise machine or exercise monitoring equipment. The

earphones of the invention include several mechanical design characteristics that ameliorate movement inaccuracies inherent in ear sensors known hitherto. It is not essential to the invention that all such preferred mechanical design characteristics be included in all embodiments of the invention.

**[0047]** Figure 3 shows the block diagram of a personal exercise device. A pair of earphones 1 that can be worn by the user is connected to a portable base unit 2 by a cable 3 having conductor means 4, 5 for carrying both audio signals and body parameter sensor signals. The portable base unit 2 has a microprocessor 8, audio module 6 for providing audio signals to the earphones, a sensor module 7 for communicating with the earphone sensors and a user interface/display module 9 for interaction with the user. In one exercise mode the exercise device determines heartbeat of the user and then controls the playback of audio content in accordance with changes in the heartbeat. The heartbeat is also recorded for future reference and for comparing against targeted training level, etc. The earphones 1 may also include an IR thermometer or small thermistor embedded in the earphones 50 for determining body temperature. The bases unit and or earphones 50 may also include an accelerometer/G-sensor for detecting steps from running or walking motion. The earphones may also include a microphone for picking up ambient sound signal and the user could enable or disable or adjusting the ratio of the mixing of ambient sound with content playing back at will. This is necessary because of the mechanical structure for the ear buds blocks a significant part of ambient sound from reaching the user.

**[0048]** The earphone mechanical design is illustrated in Figures 4 through 10. Figure 4 schematically illustrates the sensor arrangement of the earphones. Signal emitter 21, 22, 23 and detector 24, 24, 26 devices are located around the circumferential periphery 27 of the earphone. The emitter and detector devices may be either Red or Infrared (IR) or both for detecting heartbeat and optionally SpO<sub>2</sub>. The ear piece is of a type commonly known as an ear bud 50 which has a substantially cylindrical shape for insertion within the outer ear canal of the wearer. In the preferred embodiment the emitters and detectors are grouped in pairs 21-24, 22-25, 23-26 located 120 degrees apart about the circumferential periphery 27 of the ear bud 50. The dashed lines 30, 31, 32 show the path of the IR signals through the soft tissue surrounding the internal wall of the ear canal. A first signal 31 from emitter 21 is detected by detector 25, a second signal 32 from emitter 22 is detected by detector 26 and a third signal 33 from emitter 23 is detected by detector 24. The main signal noise is due to radial motion of the ear bud 50 in the x, y plane within the ear canal because these movement changes the distance between the sensor and the ear canal wall, which affects the transmitted and receive signal. By using the physical construction where the IR sensors are installed in several circular symmetric locations the effect due to motion in the x, y plane can be approximated as a linear effect on the amplitude of the received signal.

**[0049]** Some of the signal emitted from the emitters 21, 22, 23 will be reflected from the skin surface of the ear canal. The amount of the IR signals 31, 32, 33 that is reflected from the skin also varies substantially with the aforementioned x, y plane movement of the ear bud 50 within the ear canal. The reflected light is detected by the detectors and must be allowed for in later processing to determine heartbeat and other body parameters from the detected signals. The amount of referred light that is detected by the detectors can be ameliorated by locating the emitters and detectors within recess channels 35, 36, 37 below the outer peripheral surface 28 of the ear bud 50. The recess channels 35, 36, 37 can comprise air or optical glass mediums and form a narrow angle wave guide for IR signals emitted from the emitters or entering the detectors. These wave guide cannels 35, 36, 37 produces a narrow angle beam to direct the light in such a way to allow the maximum amount signal by increasing the signal path of the light up and into deeper tissue before the light reflects and is captured by the detector. They also limiting large fluctuation in DC single picked up by detectors.

**[0050]** The outer part 38 of the ear bud 50 consists of a soft over-molding made of resiliently deformable memory foam or silicone rubber that dampens the effects of motion. The foam is compressed when the ear bud 50 is inserted into the ear canal and expands to hold the bud 50 firmly in the ear canal to ameliorate relative motion between the emitters and detectors and the ear canal wall during exercise movement. One possible optional feature is to make outer piece 38 removable and interchangeable for varying the size and shape to fit a wide variety of users having different size ear canals. The properties (elasticity, softness as known as durometer, memory or rebound rate) of this soft over-molding 38 are chosen to maximizing the damping effects.

**[0051]** The depth placement of the emitters and detectors inside the ear is also important, but not essential, to reducing the effects of motion introduced within the ear during exercise. The emitters and detector are placed at the end of the inner part of the ear bud 50 which is further into the ear canal to help reduce the effects of motion. This placement helps reduce the vibration as the inner ear part is more firmly attached to the bone and muscle (non-soft tissue) which does not move as much during exercise.

**[0052]** A first arrangement of an ear bud 50 is illustrated in Figures 5 through 8. The interchangeable resilient outer part 38 is sized to fit within the ear canal of a person. Figure 7 illustrates the core parts of the ear bud 50 with the resilient outer part 38 removed. The structure consists of a speaker 44, a hollow inner core 41 for sound conduction from the speaker in to the ear, an resilient inner foam structure 42 for softness and flexibility, a flexible printed circuit (FPC) 43 or thin wirings for connection to emitter and detectors and a rubber over-molding 38 for increase comfort and protection of sensors. The resilient inner foam 42 may be compressed during insertion of the bud 50 into the ear to provide further support in the ear canal.

**[0053]** The FPC 43 comprises a hub 46 having three 120 degree radially extending arms 47. The emitter and detector

pairs 21-24, 22-25, 23-26 are located at the distal ends of the FPC 43 and are encapsulated with epoxy. The encapsulation provides a round-top to avoid injury to the user when wearing the device and at the same time prevents the emitters and receivers from damage. An alternative approach is to use sensors with suitable packaging. The FPC arms 47 are made of a flexible material so that sensors follow the foam 42 when squeezed into the ear canal. Flexible wiring tracks are located along the radial arms 47 connecting the emitters and detectors to solder bonding pads 48 on the hub 46. In one embodiment the FPC and arms is formed as a flex circuit. The hub 46 is located centrally within the back of the ear bud 50 and the radial arms brought forward within slots 45 on the surface of foam 42. The depth of the slots 45 is designed to allow the sensors to be slightly above the foam surface. The foam 42 is then covered with the rubber over-molding 38 for increase comfort and protection of sensors.

**[0054]** Figures 9 and 10 illustrate an alternative arrangement of an ear bud 50 in a behind-the-ear design. The cord 3 to each bud 50, hangs around the back of the ear to also help in securing an in ear portion 51 into the ear canal and thus reducing motion introduced into the signal by exercise movement. Another feature of this design is to have the cable 3 enter at the back or bottom of the behind the ear portion. This cable placement design will reduce the motion effects that can be produced by the pulling forces of the cable during movement. Since the cable 3 can exert a force on the ear piece the reduction of its size and weight is achieved by locating some of the electronics or circuitry into a behind an ear portion 52 of the earphone. This feature reduces the number of wires and thus thickness and weight of the cable 3. There are many wires needed to drive and capture the signal from the emitters and detector as well as the wires for the audio speakers and the temperature sensor. The circuit design has a communication method between the main unit 2 and the behind the ear portion 52 circuitry.

**[0055]** Figures 11 and 12 illustrate a second embodiment of an exercise device according to the invention employing an arm-band type sensor. In the first embodiment the sensor was a circular ear bud for location within an ear canal, with the emitters and detectors located in pairs 120 degrees apart around the outer circumference of the bud for obtaining signals from the tissue surrounding the ear canal. In the arm-band embodiment an annular band 60 is provided which locates about the wrist 61 or upper arm 62 of the user. Emitters and detectors are provided in three pairs 64, 65, 66 at locations 120 degrees apart around the inner circumference of the band 60. The emitters and detectors are of the same type as in the ear bud, however the emitters and detectors are located on the inner circumference of the band 60 so as to be pressed up against the skin of the wrist 61 or arm 62 when the band 60 is worn. The sensor signal path is through the tissue of the wrist 61 or arm 62. The band 60 is made of a resilient material so as to fit snugly about the wrist 61 or arm 62 of the wearer and maintain the emitter and detector pairs 64, 65, 66 in position with the arm tissue. The band 60 may be a stand alone band or, as illustrated in Figures 11 and 12, may be a support strap for wearing the portable base unit 2 on the wrist 61 or upper arm 62 of the users. The arm-band embodiment may be preferable to those who run or cycle in busy traffic areas and prefer not to impair their hearing with earphones for safety reasons. The embodiment shown in Figure 11 may be, for example, a wrist watch wherein the base unit only provides visual feedback. However, in some embodiments the base unit 2 may also have an ear phone output jack for connection of a standard pair of earphones for listening to music and audio feedback from the portable exercise device if so desired.

**[0056]** The head phones 1 and arm bands 60 of embodiments of the invention use multiple pairs of emitters and detectors at symmetrical locations to aid the removal or minimization of the additive noise introduced in to the detected sensor signals by exercise motion of the wearer. The microprocessor 8 of the main unit 2 receives the detected sensor signals and analyses them to detect the wearer's heartbeat and other body parameters, such as SpO2. Figure 13 is a schematic block diagram of the sensor control and processing means. A LED driver control is used to send driving signals to the LED emitters 21, 22, 23. The detected signals from detectors 24, 25, 26 are amplified by op-amps 62 with DC bias control 63. The amplified analog signals go through a multiplexer 64 and an analog-to-digital (A/D) converter 65 for input to the Microprocessor 8. The signals are analyzed in Microprocessor 8 to detect the wearer's heartbeat and other body parameters.

**[0057]** The detected signals 31, 32, 33 are modeled as follows:

$$(1) \quad m_1(t) = L_1 I_{01}(t)(1 + \gamma_1 hb(t))(1 + N_{s1}(t) + N_{f1}(t) + z_1(t))$$

$$(2) \quad m_2(t) = L_2 I_{02}(t)(1 + \gamma_2 hb(t))(1 + N_{s2}(t) + N_{f2}(t) + z_2(t)),$$

and

$$(3) \quad m_3(t) = L_3 I_{03}(t)(1 + \gamma_3 hb(t))(1 + N_{s3}(t) + N_{f3}(t) + z_3(t))$$

5 Where:

$m(t), m_2(t), m_3(t)$  are the signal received at the 3 detectors respectively

$I_{01}(t), I_{02}(t), I_{03}(t)$  are the transmitted signal to the IR LED emitters respectively

$L_1, L_2, L_3$  are constant gain of each IR sensors

10  $hb(t)$  is the heartbeat signal

$\gamma_1, \gamma_2, \gamma_3$  are coupling coefficients of the heartbeat signal  $hb(t)$

$N_{s1}(t), N_{s2}(t), N_{s3}(t)$  are slow varying noise in the detected signals

$N_{f1}(t), N_{f2}(t), N_{f3}(t)$  are typical additive thermal noise in the detected signals, and

$z_1(t), z_2(t), z_3(t)$  are noise signals due to motion.

15 [0058] This model is based on the assumption that the motion signals  $z_1(t), z_2(t), z_3(t)$  are in the same plane as the circular plane formed by the 3 sensors (the x-y plane) and they can be decomposed to 2 orthogonal components  $h(t)$  and  $v(t)$  as shown in Figure 14. Mathematically this is  $z_k(t) = \varepsilon_k(h(t)\cos(\theta_k) + v(t)\sin(\theta_k))$ , where  $h(t), v(t)$  are the motion signal being projected to horizontal and vertical directions and the direction of sensor  $k$  is  $\theta_k$  from the horizontal direction and  $\varepsilon_k$  are coupling coefficients for the motion signal to the sensors. For the three detectors 120 degrees apart  $\theta_k$  is 90, 210 and 330 degrees.

20 [0059] We can make the assuming that both  $\gamma_k, \varepsilon_k$  are much smaller than 1 and we can represent the received signal as DC and AC components ( $m_{ack}(t), m_{dck}(t)$ ). By calculating the signal AC amplitude when there is no motion, we can normalize the 3 channels gain. Equations (1),(2),(3) can be approximated as :

25

$$(4) \quad m_{ac1}(t) = hb(t) + N'_{s1}(t) + N'_{f1}(t) + z_1'(t)$$

30

$$(5) \quad m_{ac2}(t) = hb(t) + N'_{s2}(t) + N'_{f2}(t) + z_2'(t)$$

35

$$(6) \quad m_{ac3}(t) = hb(t) + N'_{s3}(t) + N'_{f3}(t) + z_3'(t)$$

where  $N'_{sk}(t), N'_{fk}(t), z_k'(t)$  are scaled versions of the original signals.

40 [0060] The signal due to heartbeat should have similar effect on the three signals 31, 32, 33 and should be in phase in each signal and differ only by a scaling factor. The sensors are placed evenly in a circle and so the effect of motion in x-y plane should be different for the 3 symmetrically located sensors. When there is no motion, or a very small amount of motion, the maximum signal to noise ratio (SNR) of the heartbeat signal can be obtained by adding up the three AC component input signal, i.e.  $y(t) = m_{ac1}(t) + m_{ac2}(t) + m_{ac3}(t)$ .

45 [0061] When there is exercise motion the noise signals  $z_1'(t), z_2'(t), z_3'(t)$  become dominated in the received signals 31, 32, 33. We can solve this problem by finding the column vector

$$\hat{w} = [w_1 \quad w_2 \quad w_3]^T \quad \text{such that} \quad \hat{y} = \hat{w}^T M$$

50

where

55

$$M = \begin{bmatrix} m_{ac1}[0] & m_{ac1}[1] & \Lambda & \Lambda & m_{ac1}[K-1] \\ m_{ac2}[0] & m_{ac2}[1] & \Lambda & \Lambda & m_{ac2}[K-1] \\ m_{ac3}[0] & m_{ac3}[1] & \Lambda & \Lambda & m_{ac3}[K-1] \end{bmatrix} \quad \text{and} \quad \hat{y} = [y[0] \quad y[1] \quad \Lambda \quad y[K-1]]$$



and  $\hat{y}$  is a linear combination of input signal which maximize :

$$\frac{\hat{w}^T \hat{s} \hat{s}^T \hat{w}}{\hat{w}^T \mathfrak{R}_{mm} \hat{w}}$$

where  $\mathfrak{R}_{mm}$  is the cross correlation matrix of the 3 signals from motion.

$$\hat{s} = [s_1 \quad s_2 \quad s_3]^T$$

is the corresponding gain of the heartbeat signal, in this case where all the 3 input channels are normalized.

$$\hat{s} = [1 \quad 1 \quad 1]^T \quad \text{and} \quad \mathfrak{R}_{mm} = MM^T - \sigma^2 \hat{s} \hat{s}^T$$

where  $\sigma^2$  is the variance of the heartbeat signal.

[0062] Since  $\mathfrak{R}_{mm}$  is positive definite, we can write :

$$\mathfrak{R}_{mm} = R^{\frac{1}{2}} \cdot R^{\frac{1}{2}} \quad \text{and we write} \quad \hat{u} = R^{\frac{1}{2}} \hat{w}$$

$$\hat{w} = R^{-\frac{1}{2}} \hat{u}$$

[0063] The problem becomes :

$$\max_{\|\hat{u}\|=1} \hat{u}^T R^{-\frac{1}{2}} \hat{s} \cdot \hat{s}^T R^{-\frac{1}{2}} \hat{u}$$

or

$$\max_{\|\hat{u}\|=1} (\hat{u}^T R^{-\frac{1}{2}} \hat{s})^2$$

[0064] The expression is maximum when :

$$\hat{u} = R^{-\frac{1}{2}} \hat{s}$$

$$\therefore \hat{w} = R^{-\frac{1}{2}} (R^{-\frac{1}{2}} \hat{s}) = \mathfrak{R}_{mm}^{-1} \hat{s}$$

where

$$\mathfrak{R}_{mm} = MM^T - \sigma^2 \hat{S} \hat{S}^T$$

5 [0065] The amplitude of 3 input heartbeat signal is normalized by calculating the variance (or standard deviation) of each channel when the user is not running.

[0066] Figure 15 schematically illustrates the processing of the sensor signals 31, 32, 33 to determine heartbeat. The following is a description of each block.

10 Block 71:

[0067] A simple Finite Input Response (FIR) low pass filter is used to remove all high frequency signals. Slow drifting DC offset is removed using a filter or a moving window to extract the DC offset and subtract back from the signal.

15 Block 72:

[0068] The signal amplitude of the heartbeat signal on each sensor is identified when there is no user motion. This is done by calculating the standard deviation of the 3 input signals when there is no motion. The 3 signal paths are then normalized.

20

Block 73:

[0069] We then determine whether there is motion. The signal are check in the time domain. If the heartbeat signal dominates, all the 3 signals should be synchronous and in-phase. If the motion of the user is big enough, it is expected that the signal from motion dominates and sensor signals should not be all in phase. The correlation index across the three signals is calculated. The amplitude of the signal when compared with rest time signal amplitude is a clear indicator for motion.

25

[0070] If there is no motion the three signals are added together (with normalized amplitude) to improve the SNR.

[0071] If there is motion : e.g. running, the acquired signals are cut into blocks of length K for calculating the covariance matrix

30

$$\mathfrak{R}_{mm} = MM^T - \sigma^2 \hat{S} \hat{S}^T .$$

35

$\sigma^2 \hat{S} \hat{S}^T$  can be obtained calculating the standard deviation of the 3 input signals when there is no motion. The 3 input signals are then normalized to having signal standard deviation of  $\sigma$  when there is no motion. Then  $\sigma^2 \hat{S} \hat{S}^T$  becomes

40

$$\sigma^2 \begin{bmatrix} 1 & 1 & 1 \\ 1 & 1 & 1 \\ 1 & 1 & 1 \end{bmatrix}$$

45

[0072] We then calculate the vector :

50

$$w = \mathfrak{R}_{mm}^{-1} \hat{S}$$

All 3 channels are calibrated and normalized when there is no motion

55

$$\hat{S} = [1 \quad 1 \quad 1]^T$$

w is a 3x1 column vector :

$$\hat{y} = \hat{w}^T M$$

$y[n]$  is a linear combination of the 3 input signals

the signal due to motion should be canceled out and preserve the heartbeat signal

[0073] The linear combination may also be done in frequency domain as well. The time domain waveform can be restored using an inverse Fast Fourier Transform (FFT). The signal  $y[n]$  should contain the heartbeat signal + noise.

Block 74

[0074] The heartbeat signal is detected using match filters in the time domain. The user's resting heartbeat rate signal can be recorded as templates. The corresponding heart rate of these templates can be calculated and recorded as well. For each range of the heart rate, a template is stored for each user. For the range where there is no recorded template a time wrapping approach is used to predict an approximate template. These templates are then used to build multiple matched filters for the user. The corresponding matched filter will be selected according to current heartbeat rate of the user.

Block 76

[0075] The peaks of the matched filter output are detected and they are marked as the beat time. The inter-beat intervals are calculated and stored in a buffer.

Block 77

[0076] Based on the current beat rate, an algorithm was implemented to detect missed and false alarm of the beats. In case of a miss or false alarm the inter-beat intervals will be modified accordingly to improve accuracy of the heart rate calculation.

Block 78

[0077] The heart rate is then calculated from the inter-beat intervals buffer.

[0078] In addition to detecting the heart beat signal, a method is employed to extract the motion signal from the sensor signals. When the user is running, each of the input signals is the sum of the heart beat signal and the motion signal. Figure 16 shows the three sensor signals before and after the user starts to jog or run. Prior to running the three heart beat signals are in phase and of the same amplitude. When the user starts to jog or run the motion signals amplitude varies a lot among the three sensor signals. To accurately detect the step rate instead of the heart rate, it is necessary to remove the heart beat signal from the sensor signals. Step detection is activated only when it is determined that the user is running, which is described earlier. When user is running or jogging, the standard deviation of the three sensor signals is calculated for certain window width, typical 2 seconds. The standard deviation is use as a parameter representing the amplitude of the sensor signals. If the amplitude of the signal with the biggest amplitude is bigger than the rest time heart beat signal amplitude by certain ratio, in the preferred example 10, it is assumed that the motion signal completely dominates and this biggest emplitude signal is chosen as the motion signal, i.e.

$$y_{MOTION}(t) = m_{ac\_biggest}(t)$$

where  $m_{ac\_biggest}(t)$  is the input signal with biggest amplitude and the amplitude is bigger than the rest time heart beat signal by 10 times. If no sensor signal is ten times greater than the rest time heart beat signal, the standard deviation of the sensor signals are compared and ranked. The motion signals is the two biggest sensor signals minus two-times the smallest sensor signal, i.e.

$$y_{MOTION}(t) = m_{ac\_big1}(t) + m_{ac\_big2}(t) - 2m_{ac\_smallest}(t)$$

5 where  $m_{ac\_big1}(t)$ ,  $m_{ac\_big2}(t)$  are the 2 input signals with bigger amplitude and  $m_{ac\_smallest}(t)$  is the input signal with smallest amplitude.

[0079] The reason for this simple formulation is that all the three sensor signals should contain a heart beat signal components with substantial identical amplitude. The components due to heart beat signal should cancel out most of the heart beat signal. The resultant motion signal,  $y_{MOTION}(t)$ , is a large amplitude sinusoidal signal with good signal to noise ratio and thus a simple zero crossing method can be used to determine the step counts when user is running: Suitable zero crossing methods should be well known in the art. Figure 17 is a flow chart of this method.

[0080] In order to determine distance run the distance per step must be known for the particular user. This can be input manually by user if they know or can calculate their typical stride length, or the device can be put in to calibration mode which requires the user to walk and run for a certain distance. Figure 18 shows the relationship of the step distance and the rate of steps. The data point will then be used to interpolate or extrapolate the curve of step distance versus rate of step. After the steps are detected, the rate of the step and the number of step will be calculated. The rate of steps will be used to estimate the distance traveled of each steps. The step distance is accumulated and will be recorded as the total workout distance traveled when the workout is finished.

[0081] The exercise device processes, displays and stores health related data, such as heart rate, blood oxygen level (SpO2), body temperature, steps walked or run, entered weight to calculate calories burned and body mass index (BMI). The user connects to the headphones that not only playback audio files but also simultaneously captures end users health related data inside the ear. The data is transferred to the portable entertainment device and workout assistant for processing, displaying/notifying and storing the data.

[0082] The following various functions are available on the device. This is, however, not an exhaustive list and more or less features may be included in some embodiments.

[0083] Preferred features include;-

1. Playback of the audio/video files stored on the device,
2. Determining and displaying the instantaneous heart rate and storing a heart rate profile during an exercise period.
3. Storing and displaying the number of steps taken.
4. Determining, displaying and storing the health related status of the end user, including temperature, blood oxygen level and other body parameters.
5. Providing visual and audio feedback of target exercise parameters and/or rates to help the end user optimize his physical activity - for example a pre approved beep as a sign to slow down, a pre approved different signal/sound for signaling end user to pick up the pace and a pre defined sound for providing signal on what percentage of the exercise has been completed.
6. Transfer of data to a PC for further analysis, review or summary,
7. Providing visual and audio feedback, for example via pause or stop playback, if the device detects one or more of the ear buds is not capturing a heartbeat which mean a possible detach and resume playback after the device detects a heartbeat from one or both of the ear buds.
8. Providing visual and audio feedback of target exercise parameters by changing the tempo, pitch, equalizer according to the inputted vital sign so as to raise or reduce the workout intensity of the user sub-consciously - Figures 19 and 20 shows the block diagram of the way to implement the change of audio signal based on vital sign.
9. Providing visual and audio feedback of target exercise distance by changing the temp, pitch, equalizer according to the inputted step rate and distance traveled.

## Claims

1. A noninvasive light sensor for detecting heart beat signals, comprising:
  - a circular support member engageable circumferentially with a body part of a person,
  - a plurality of light emitters located about a circumference of the circular support member for emitting light signals into different areas of tissue surrounding the body part, and
  - a plurality of light detectors located about a circumference of the circular support member for receiving reflected light signals from the different areas of tissue surrounding the body part.

2. The noninvasive light sensor of claim 1 wherein plurality of light emitters consist of three light emitters located 120 degrees apart about the circumference of the support member.
- 5 3. The noninvasive light sensor of claims 1 or 2 wherein the plurality of light detectors consist of three light detectors located 120 degrees apart about the circumference of the support member.
4. The noninvasive light sensor of any preceding claim wherein the light emitters and light detectors are located in pairs consisting of one of the emitters and one of the detectors.
- 10 5. The noninvasive light sensor of any preceding claim wherein the circular support member being an ear bud insertable with the an ear canal along an ear canal axis, wherein the plurality of light emitters are located about the periphery of the ear piece for emitting light signals perpendicular to the ear canal axis into the different areas of tissue surrounding the ear canal, and the plurality of light detectors are located about the periphery of the ear piece for receiving reflected light signals from the different areas of tissue surrounding the ear canal.
- 15 6. The noninvasive light sensor of claim 5 wherein the ear piece is resiliently deformable for expansion within the ear canal, such that the ear piece is firmly locatable within the ear canal.
- 20 7. The noninvasive light sensor of claims 5 or 6 wherein the ear price comprises an inner layer and an outer layer having a plurality of openings, the light emitters and light detectors located within the outer layer openings.
8. The noninvasive light sensor of claim 7 wherein the openings have light absorbent sides surrounding the light emitters and light detectors, the sides defining a narrow gap above the light emitters and light detectors.
- 25 9. The noninvasive light sensor of claim 1 wherein the support member comprising a band locatable about a wrist or arm, the emitters and detectors located around an inner circumference of the band for respectively emitting light signals into the different areas of arm tissue and receiving reflected light from the different areas of arm tissue.
- 30 10. A exercise system comprising:  
 an ear piece insertable within an ear canal along a canal axis, the ear piece having a plurality of light sensors and detectors, and a audio speaker,  
 a computer readable storage medium have space allocated for storage of audio files,  
 a vital sign monitor programmed to generating a vital sign signal from signals of the emitters and detectors, and  
 35 an audio player programmed to playback audio files thought the audio speaker in response to the vital sign signal and to vary attributes of the playback audio files in response to the vital sign signal.
- 40 11. The exercise system of claim 10 wherein the attributes of the playback audio files to be varied include one or more of beat, tempo, tone, pitch and the audio filed being played.
12. The exercise system of claims 10 or 11 wherein the vital sign monitor is programmed to generating a heart rate, blood oxygen or temperature signal.
- 45 13. A method of determining heart rate of a person during exercise comprising:  
 obtaining a plurality of sensor signals from multiple locations about a body part of a person, the sensor signals comprising a heart beat signals and a movement signals,  
 comparing the signals to separate the heart beat signals and a movement signals, and  
 50 determining heart rate from the heart beat signals.
14. The method of claim 13 wherein obtaining a plurality of sensor signals from locations comprises providing a plurality of heart beat sensors for positioning at multiple locations about the body part.
- 55 15. The method of claims 13 or 14 wherein comparing the signals to separate the heart beat signals and a movement signals comprises comparing the sensor signals to find in phase and out of phase components of the sensor signals.
16. The method of any one of claims 13 to 15 wherein comparing the signals to separate the heart beat signals and a movement signals comprises finding a covariance between the sensor signals.

17. The method of any one of claims 13 to 16 wherein determining heart rate from the heart beat signals comprises using match filters.

5

10

15

20

25

30

35

40

45

50

55

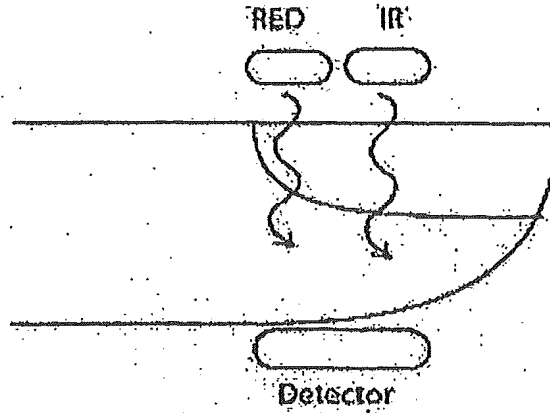

Figure 1 (Prior Art)

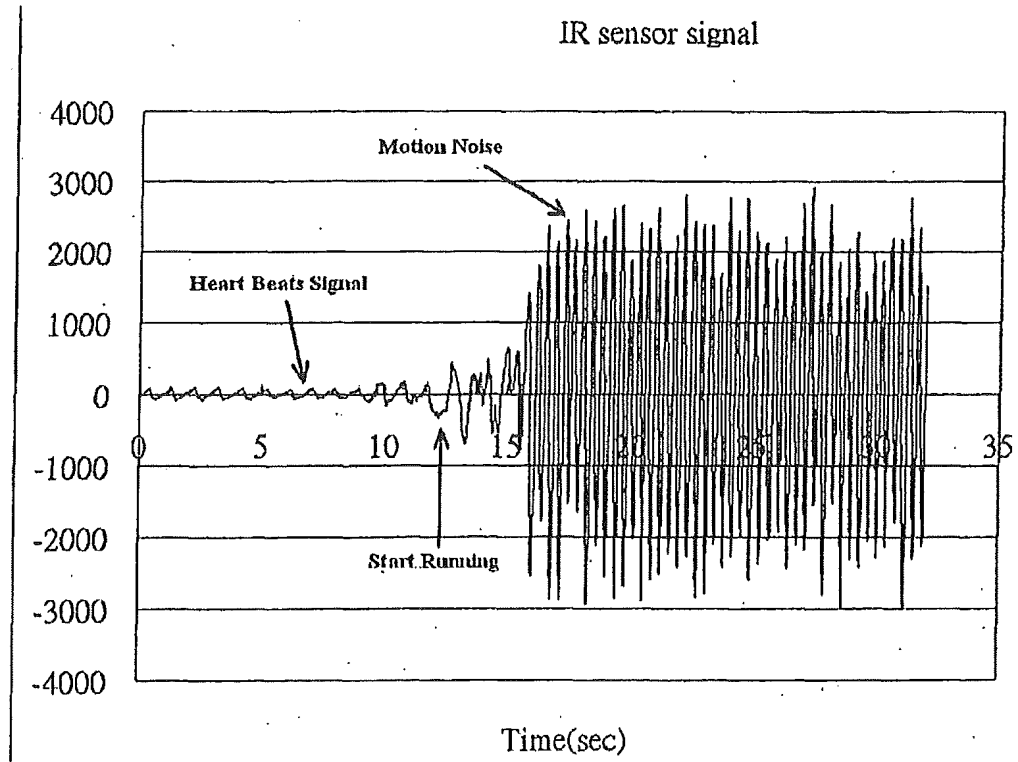

Figure 2 (Prior Art)

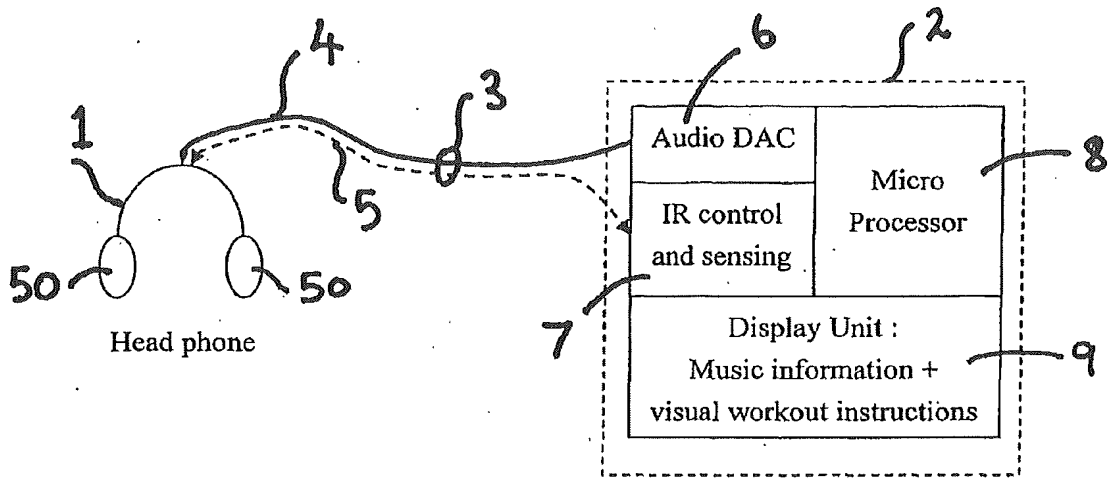

Figure 3

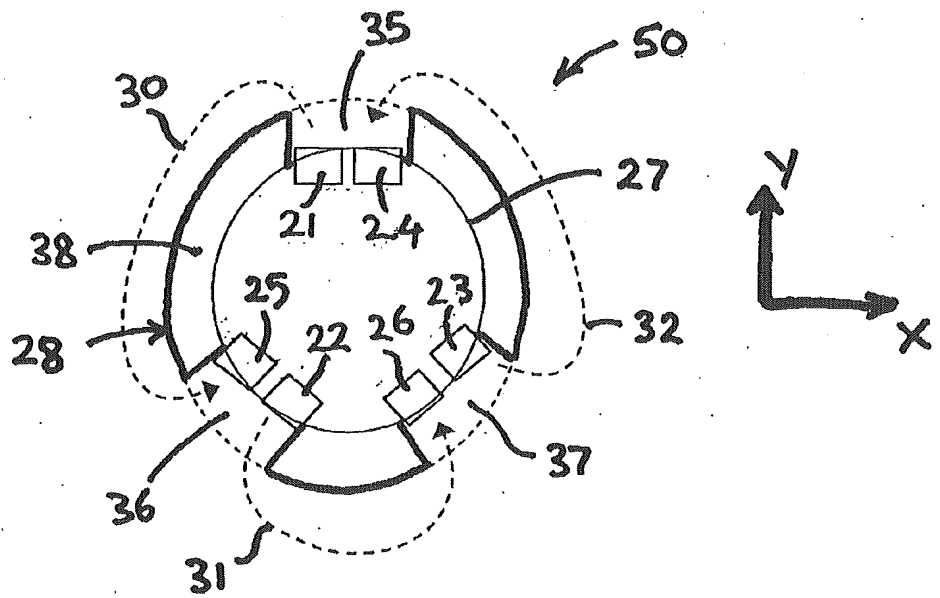

Figure 4



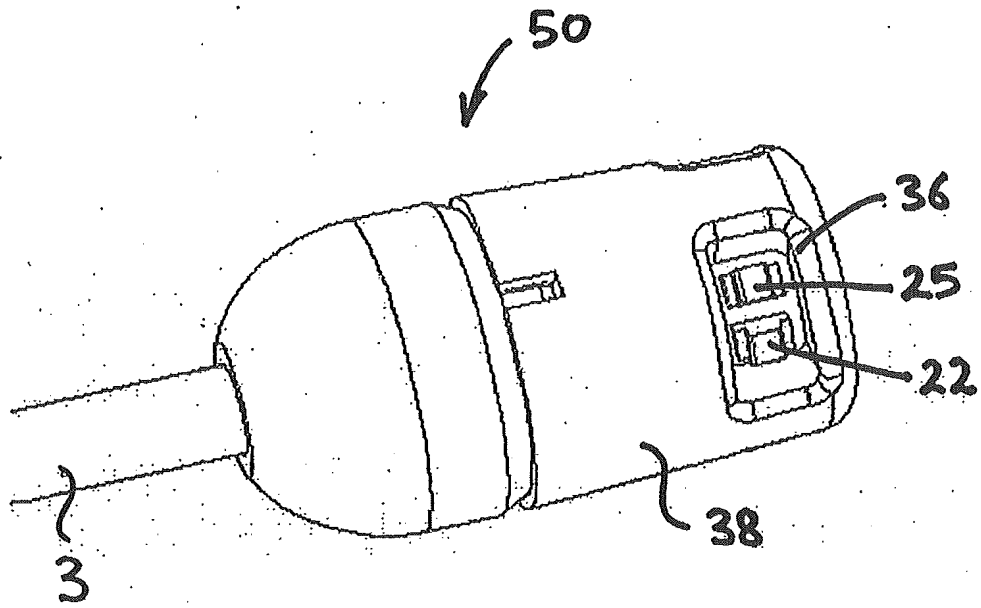

Figure 5

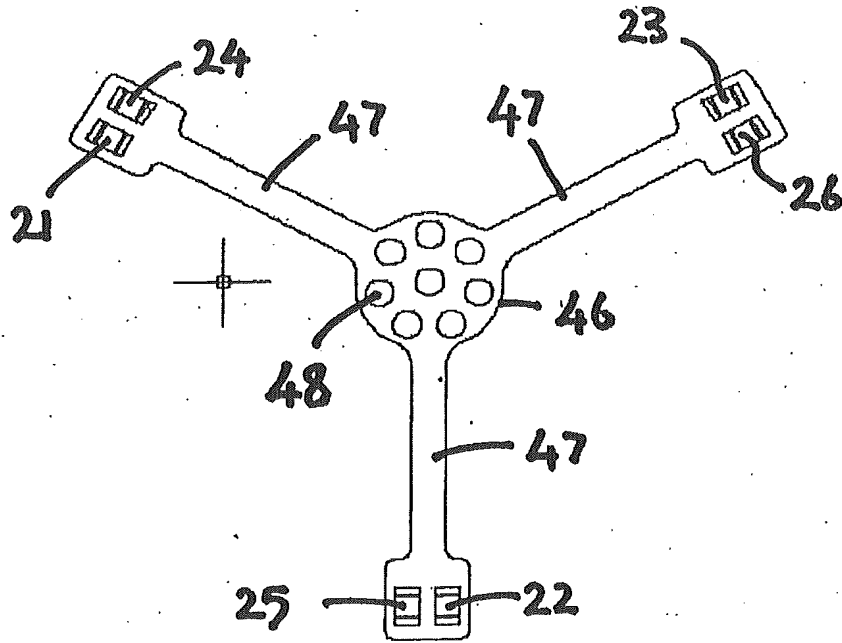

Figure 6

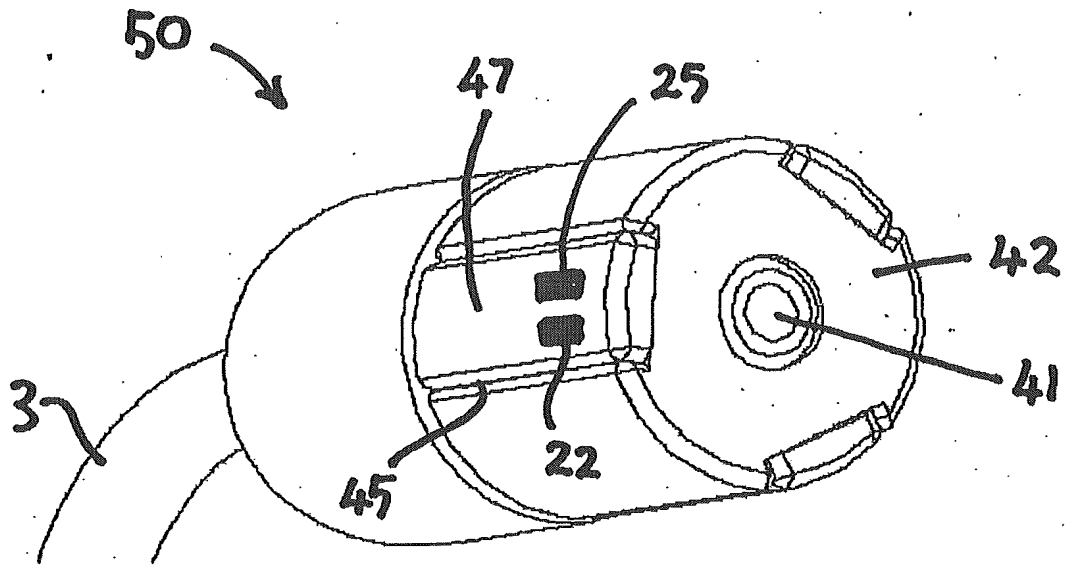

Figure 7

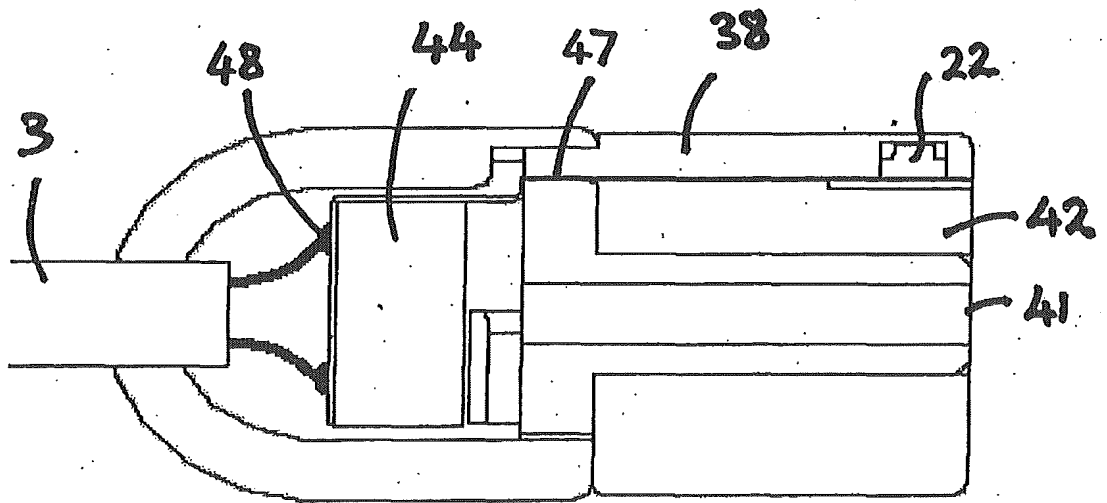

Figure 8

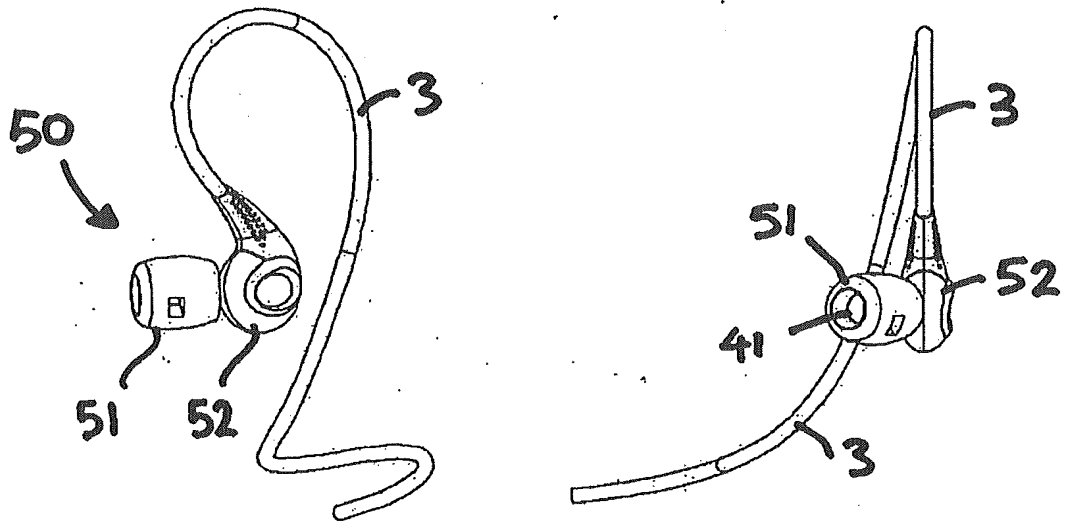

Figure 9

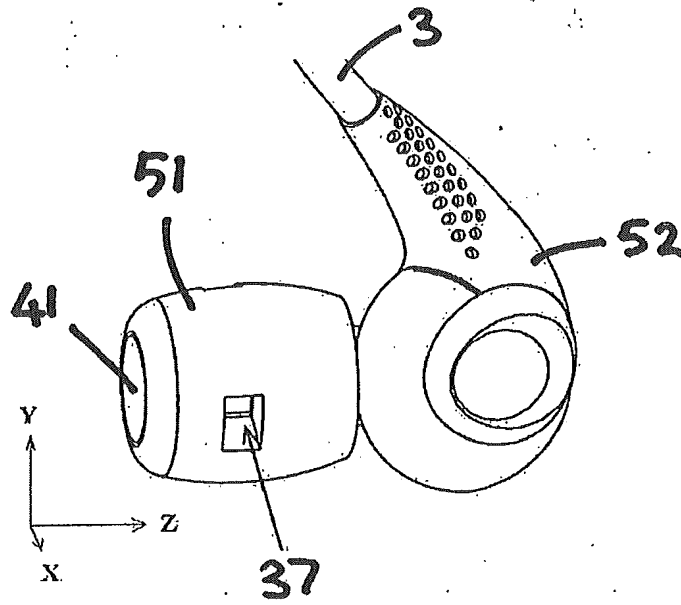

Figure 10

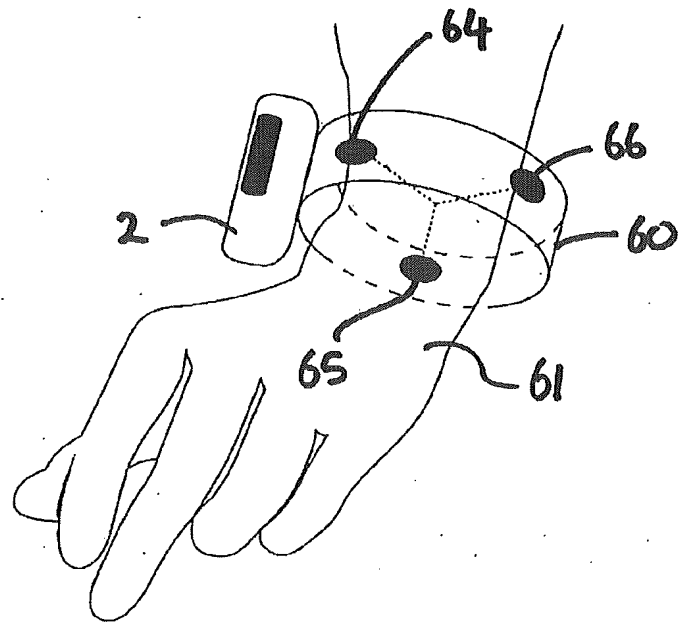

Figure 11

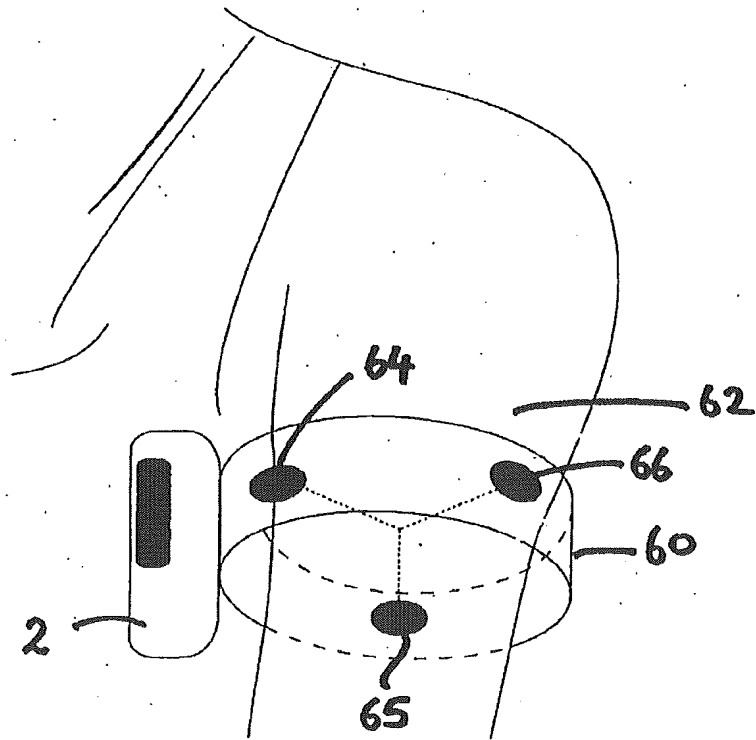

Figure 12

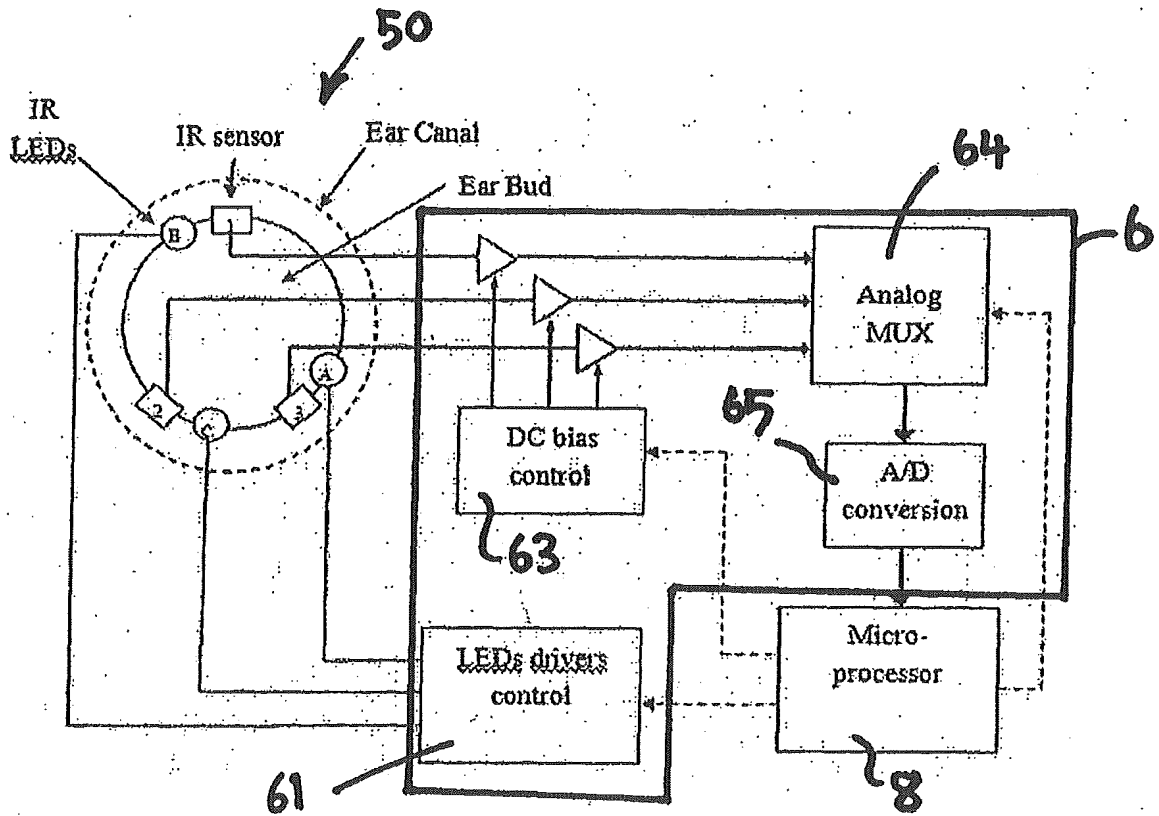

Figure 13

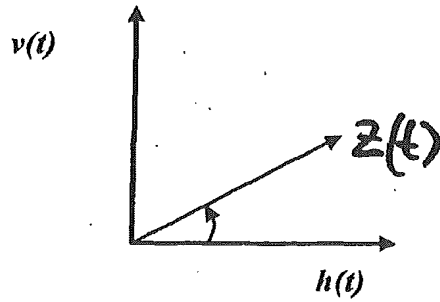

Figure 14

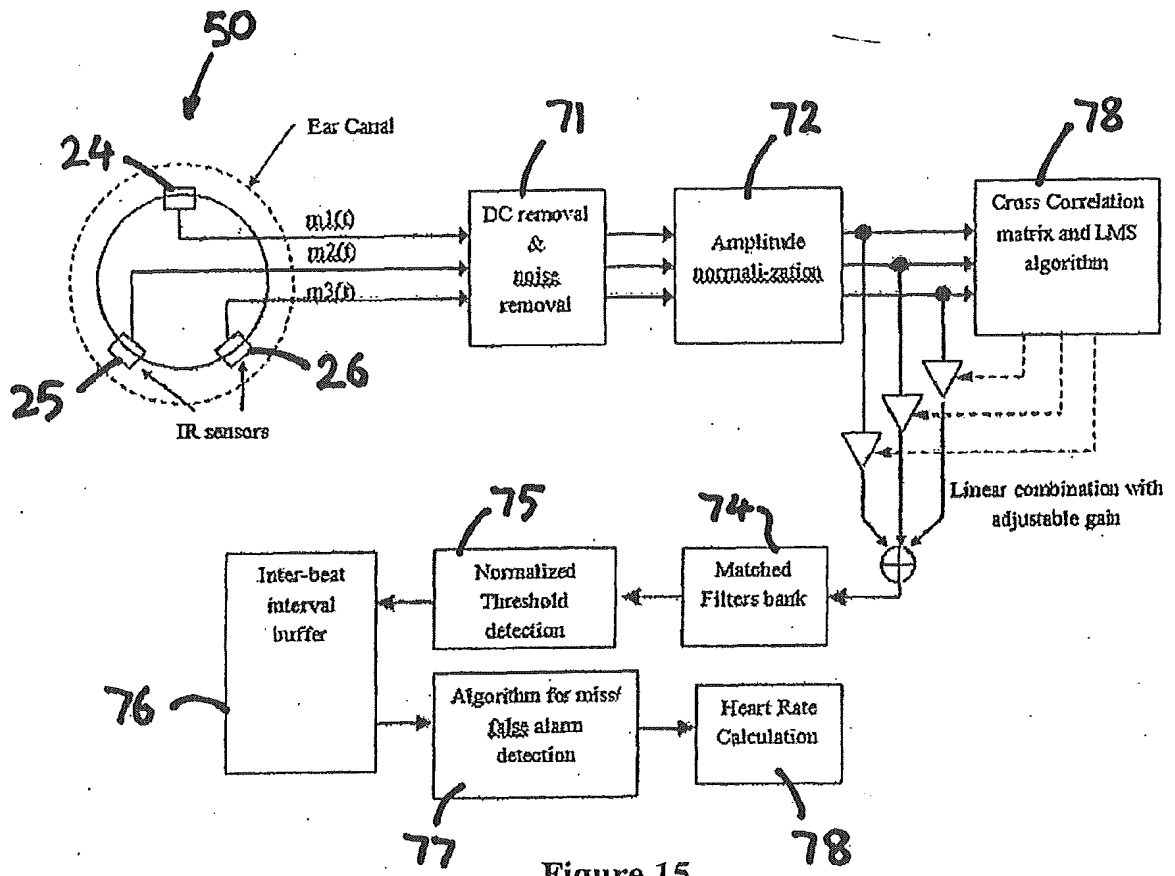

Figure 15

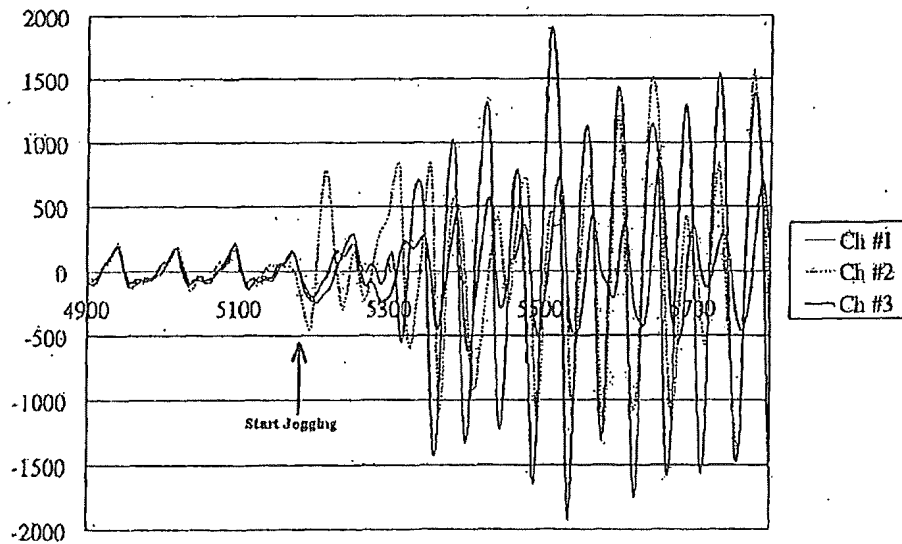

Figure 16

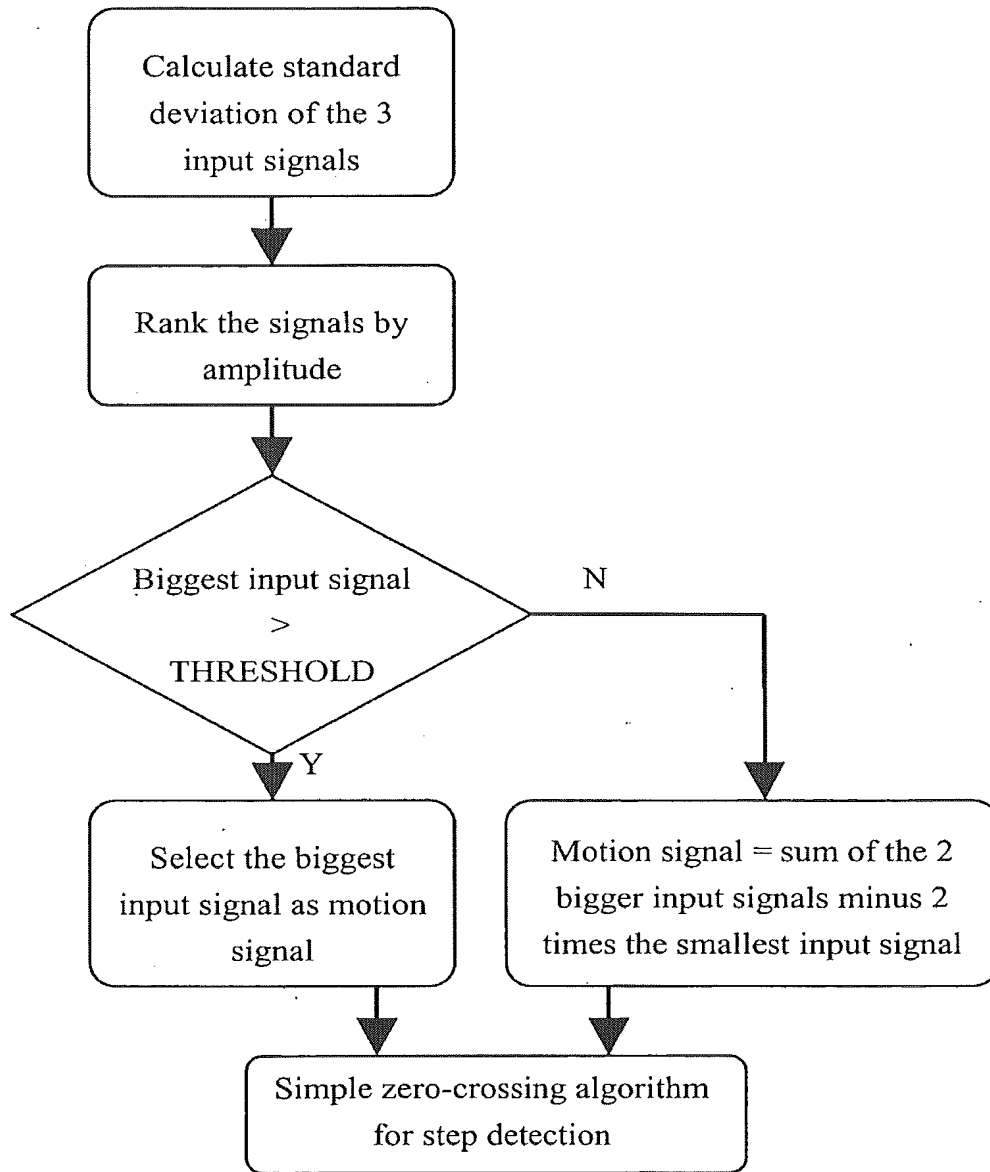

Figure 17

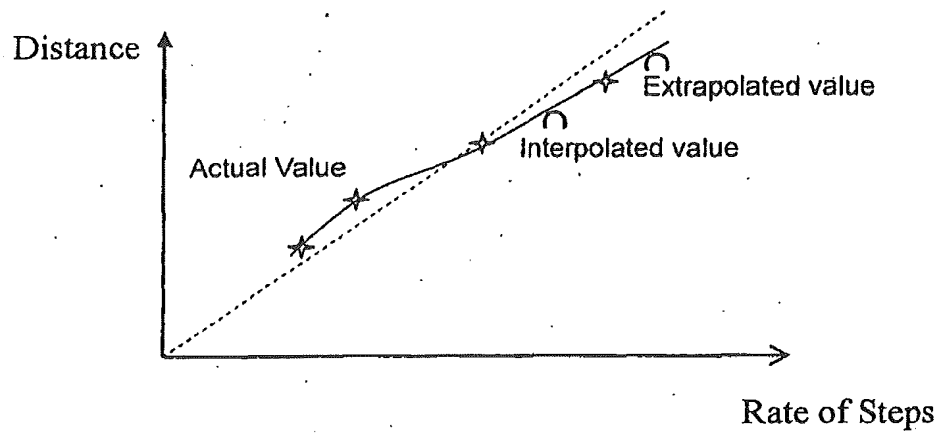

Figure 18

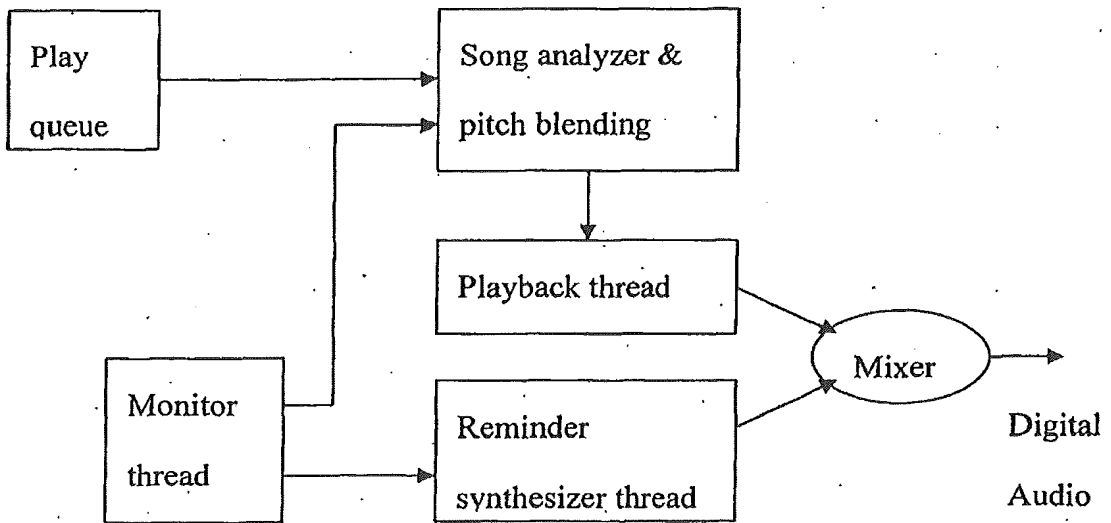

Figure 19



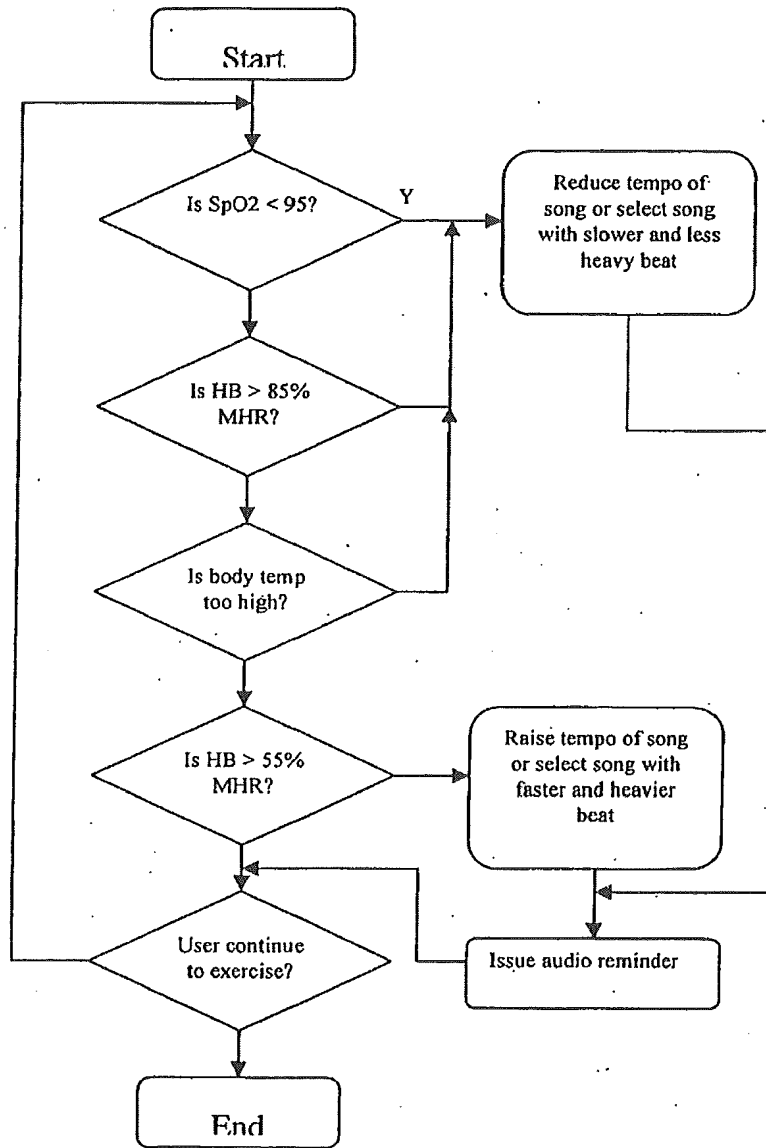

Figure 20

**REFERENCES CITED IN THE DESCRIPTION**

*This list of references cited by the applicant is for the reader's convenience only. It does not form part of the European patent document. Even though great care has been taken in compiling the references, errors or omissions cannot be excluded and the EPO disclaims all liability in this regard.*

**Non-patent literature cited in the description**

- **M.R. Neuman ; N. Wang.** Motion Artifact in Pulse Oximetry. *Annual International Conference of the IEEE Engineering in Medicine and Biology Society*, 1990, vol. 12 (5 [0006])

## Electronic Acknowledgement Receipt

<b>EFS ID:</b>	19964662
<b>Application Number:</b>	14184396
<b>International Application Number:</b>	
<b>Confirmation Number:</b>	8272
<b>Title of Invention:</b>	METHODS AND APPARATUS FOR GENERATING DATA OUTPUT CONTAINING PHYSIOLOGICAL AND MOTION-RELATED INFORMATION
<b>First Named Inventor/Applicant Name:</b>	Steven Francis LeBoeuf
<b>Customer Number:</b>	20792
<b>Filer:</b>	Needham J. Boddie/Susan E. Freedman
<b>Filer Authorized By:</b>	Needham J. Boddie
<b>Attorney Docket Number:</b>	9653-7TSCT2
<b>Receipt Date:</b>	26-AUG-2014
<b>Filing Date:</b>	19-FEB-2014
<b>Time Stamp:</b>	11:59:52
<b>Application Type:</b>	Utility under 35 USC 111(a)

### Payment information:

Submitted with Payment	no
------------------------	----

### File Listing:

Document Number	Document Description	File Name	File Size(Bytes)/ Message Digest	Multi Part /.zip	Pages (if appl.)
1		9763-7TSCT2_2014-08-26_Resp onse.pdf	1218062  d761e807020747da3f044b6e3da59c61f86 b4385	yes	13

Multipart Description/PDF files in .zip description					
Document Description			Start	End	
Amendment/Req. Reconsideration-After Non-Final Reject			1	1	
Specification			2	2	
Claims			3	6	
Applicant Arguments/Remarks Made in an Amendment			7	13	
<b>Warnings:</b>					
<b>Information:</b>					
2		9653-7TSCT2_2014-08-26_IDS.pdf	326365	yes	3
			47f2e7d87ad6023f75f6578a256dffbf51c5c6f5		
Multipart Description/PDF files in .zip description					
Document Description			Start	End	
Transmittal Letter			1	2	
Information Disclosure Statement (IDS) Form (SB08)			3	3	
<b>Warnings:</b>					
<b>Information:</b>					
3	Foreign Reference	EP2077091.pdf	2502285	no	26
			bd8becf245c00184685e47afb38ef5aad617f3c4		
<b>Warnings:</b>					
<b>Information:</b>					
<b>Total Files Size (in bytes):</b>			4046712		

**This Acknowledgement Receipt evidences receipt on the noted date by the USPTO of the indicated documents, characterized by the applicant, and including page counts, where applicable. It serves as evidence of receipt similar to a Post Card, as described in MPEP 503.**

**New Applications Under 35 U.S.C. 111**

**If a new application is being filed and the application includes the necessary components for a filing date (see 37 CFR 1.53(b)-(d) and MPEP 506), a Filing Receipt (37 CFR 1.54) will be issued in due course and the date shown on this Acknowledgement Receipt will establish the filing date of the application.**

**National Stage of an International Application under 35 U.S.C. 371**

**If a timely submission to enter the national stage of an international application is compliant with the conditions of 35 U.S.C. 371 and other applicable requirements a Form PCT/DO/EO/903 indicating acceptance of the application as a national stage submission under 35 U.S.C. 371 will be issued in addition to the Filing Receipt, in due course.**

**New International Application Filed with the USPTO as a Receiving Office**

**If a new international application is being filed and the international application includes the necessary components for an international filing date (see PCT Article 11 and MPEP 1810), a Notification of the International Application Number and of the International Filing Date (Form PCT/RO/105) will be issued in due course, subject to prescriptions concerning national security, and the date shown on this Acknowledgement Receipt will establish the international filing date of the application.**

<b>Doc Code: DIST.E.FILE</b> <b>Document Description: Electronic Terminal Disclaimer - Filed</b>	PTO/SB/25 PTO/SB/26 U.S. Patent and Trademark Office Department of Commerce
---	--

Electronic Petition Request	<b>TERMINAL DISCLAIMER TO OBVIATE A PROVISIONAL DOUBLE PATENTING REJECTION OVER A PENDING "REFERENCE" APPLICATION AND TERMINAL DISCLAIMER TO OBVIATE A DOUBLE PATENTING REJECTION OVER A "PRIOR" PATENT</b>
Application Number	14184396
Filing Date	19-Feb-2014
First Named Inventor	Steven LeBoeuf
Attorney Docket Number	9653-7TSCT2
Title of Invention	METHODS AND APPARATUS FOR GENERATING DATA OUTPUT CONTAINING PHYSIOLOGICAL AND MOTION-RELATED INFORMATION

- Filing of terminal disclaimer does not obviate requirement for response under 37 CFR 1.111 to outstanding Office Action
- This electronic Terminal Disclaimer is not being used for a Joint Research Agreement.

Owner	Percent Interest
Valencell, Inc.	100 %

The owner(s) of percent interest listed above in the instant application hereby disclaims, except as provided below, the terminal part of the statutory term of any patent granted on the instant application which would extend beyond the expiration date of the full statutory term of any patent granted on pending reference Application Number(s)

14194891 filed on 03/03/2014

as the term of any patent granted on said reference application may be shortened by any terminal disclaimer filed prior to the grant of any patent on the pending reference application. The owner hereby agrees that any patent so granted on the instant application shall be enforceable only for and during such period that it and any patent granted on the reference application are commonly owned. This agreement runs with any patent granted on the instant application and is binding upon the grantee, its successors or assigns.

In making the above disclaimer, the owner does not disclaim the terminal part of any patent granted on the instant application that would extend to the expiration date of the full statutory term of any patent granted on said reference application, "as the term of any patent granted on said reference application may be shortened by any terminal disclaimer filed prior to the grant of any patent on the pending reference application," in the event that any such patent granted on the pending reference application: expires for failure to pay a maintenance fee, is held unenforceable, is found invalid by a court of competent jurisdiction, is statutorily disclaimed in whole or terminally disclaimed under 37 CFR 1.321, has all claims canceled by a reexamination certificate, is reissued, or is in any manner terminated prior to the expiration of its full statutory term as shortened by any terminal disclaimer filed prior to its grant.

The owner(s) with percent interest listed above in the instant application hereby disclaims, except as provided below, the terminal part of the statutory term of any patent granted on the instant application which would extend beyond the expiration date of the full statutory term of prior patent number(s)

8700111

as the term of said prior patent is presently shortened by any terminal disclaimer. The owner hereby agrees that any patent so granted on the instant application shall be enforceable only for and during such period that it and the prior patent are commonly owned. This agreement runs with any patent granted on the instant application and is binding upon the grantee, its successors or assigns.

In making the above disclaimer, the owner does not disclaim the terminal part of the term of any patent granted on the instant application that would extend to the expiration date of the full statutory term of the prior patent, "as the term of said prior patent is presently shortened by any terminal disclaimer," in the event that said prior patent later:

- expires for failure to pay a maintenance fee;
- is held unenforceable;
- is found invalid by a court of competent jurisdiction;
- is statutorily disclaimed in whole or terminally disclaimed under 37 CFR 1.321;
- has all claims canceled by a reexamination certificate;
- is reissued; or
- is in any manner terminated prior to the expiration of its full statutory term as presently shortened by any terminal disclaimer.

- Terminal disclaimer fee under 37 CFR 1.20(d) is included with Electronic Terminal Disclaimer request.
- I certify, in accordance with 37 CFR 1.4(d)(4), that the terminal disclaimer fee under 37 CFR 1.20(d) required for this terminal disclaimer has already been paid in the above-identified application.

Applicants claims the following fee status:

- Small Entity
- Micro Entity
- Regular Undiscounted

I hereby declare that all statements made herein of my own knowledge are true and that all statements made on information and belief are believed to be true; and further that these statements were made with the knowledge that willful false statements and the like so made are punishable by fine or imprisonment, or both, under Section 1001 of Title 18 of the United States Code and that such willful false statements may jeopardize the validity of the application or any patent issued thereon.

THIS PORTION MUST BE COMPLETED BY THE SIGNATORY OR SIGNATORIES

I certify, in accordance with 37 CFR 1.4(d)(4) that I am:

- An attorney or agent registered to practice before the Patent and Trademark Office who is of record in this application  
  
Registration Number 40519
- A sole inventor
- A joint inventor; I certify that I am authorized to sign this submission on behalf of all of the inventors as evidenced by the power of attorney in the application
- A joint inventor; all of whom are signing this request

Signature	/Needham J. Boddie, II/
Name	Needham J. Boddie, II

\*Statement under 37 CFR 3.73(b) is required if terminal disclaimer is signed by the assignee (owner).  
Form PTO/SB/96 may be used for making this certification. See MPEP § 324.



## Electronic Patent Application Fee Transmittal

<b>Application Number:</b>	14184396
<b>Filing Date:</b>	19-Feb-2014
<b>Title of Invention:</b>	METHODS AND APPARATUS FOR GENERATING DATA OUTPUT CONTAINING PHYSIOLOGICAL AND MOTION-RELATED INFORMATION
<b>First Named Inventor/Applicant Name:</b>	Steven Francis LeBoeuf
<b>Filer:</b>	Needham J. Boddie
<b>Attorney Docket Number:</b>	9653-7TSCT2

Filed as Large Entity

### Utility under 35 USC 111(a) Filing Fees

Description	Fee Code	Quantity	Amount	Sub-Total in USD(\$)
<b>Basic Filing:</b>				
Statutory or Terminal Disclaimer	1814	1	160	160

**Pages:**

**Claims:**

**Miscellaneous-Filing:**

**Petition:**

**Patent-Appeals-and-Interference:**

**Post-Allowance-and-Post-Issuance:**

**Extension-of-Time:**

Description	Fee Code	Quantity	Amount	Sub-Total in USD(\$)
<b>Miscellaneous:</b>				
<b>Total in USD (\$)</b>				<b>160</b>

Doc Code: DISQ.E.FILE

Document Description: Electronic Terminal Disclaimer – Approved

Application No.: 14184396

Filing Date: 19-Feb-2014

Applicant/Patent under Reexamination: LeBoeuf et al.

Electronic Terminal Disclaimer filed on August 26, 2014

APPROVED

**This patent is subject to a terminal disclaimer**

DISAPPROVED

Approved/Disapproved by: Electronic Terminal Disclaimer automatically approved by EFS-Web

U.S. Patent and Trademark Office

## Electronic Acknowledgement Receipt

<b>EFS ID:</b>	19964765
<b>Application Number:</b>	14184396
<b>International Application Number:</b>	
<b>Confirmation Number:</b>	8272
<b>Title of Invention:</b>	METHODS AND APPARATUS FOR GENERATING DATA OUTPUT CONTAINING PHYSIOLOGICAL AND MOTION-RELATED INFORMATION
<b>First Named Inventor/Applicant Name:</b>	Steven Francis LeBoeuf
<b>Customer Number:</b>	20792
<b>Filer:</b>	Needham J. Boddie
<b>Filer Authorized By:</b>	
<b>Attorney Docket Number:</b>	9653-7TSCT2
<b>Receipt Date:</b>	26-AUG-2014
<b>Filing Date:</b>	19-FEB-2014
<b>Time Stamp:</b>	12:08:21
<b>Application Type:</b>	Utility under 35 USC 111(a)

### Payment information:

Submitted with Payment	yes
Payment Type	Deposit Account
Payment was successfully received in RAM	\$160
RAM confirmation Number	9163
Deposit Account	500220
Authorized User	

### File Listing:

Document Number	Document Description	File Name	File Size(Bytes)/ Message Digest	Multi Part /.zip	Pages (if appl.)
-----------------	----------------------	-----------	----------------------------------	------------------	------------------

1	Electronic Terminal Disclaimer-Filed	eTerminal-Disclaimer.pdf	35995	no	3
			9313e1193cc2638e60bc7246e7d591f0188353e2		
<b>Warnings:</b>					
<b>Information:</b>					
2	Fee Worksheet (SB06)	fee-info.pdf	30534	no	2
			dff4ab5c8cdeebc64032325385c835e84c4c8453		
<b>Warnings:</b>					
<b>Information:</b>					
<b>Total Files Size (in bytes):</b>			66529		

**This Acknowledgement Receipt evidences receipt on the noted date by the USPTO of the indicated documents, characterized by the applicant, and including page counts, where applicable. It serves as evidence of receipt similar to a Post Card, as described in MPEP 503.**

**New Applications Under 35 U.S.C. 111**

**If a new application is being filed and the application includes the necessary components for a filing date (see 37 CFR 1.53(b)-(d) and MPEP 506), a Filing Receipt (37 CFR 1.54) will be issued in due course and the date shown on this Acknowledgement Receipt will establish the filing date of the application.**

**National Stage of an International Application under 35 U.S.C. 371**

**If a timely submission to enter the national stage of an international application is compliant with the conditions of 35 U.S.C. 371 and other applicable requirements a Form PCT/DO/EO/903 indicating acceptance of the application as a national stage submission under 35 U.S.C. 371 will be issued in addition to the Filing Receipt, in due course.**

**New International Application Filed with the USPTO as a Receiving Office**

**If a new international application is being filed and the international application includes the necessary components for an international filing date (see PCT Article 11 and MPEP 1810), a Notification of the International Application Number and of the International Filing Date (Form PCT/RO/105) will be issued in due course, subject to prescriptions concerning national security, and the date shown on this Acknowledgement Receipt will establish the international filing date of the application.**

Under the Paperwork Reduction Act of 1995, no persons are required to respond to a collection of information unless it displays a valid OMB control number.

<b>PATENT APPLICATION FEE DETERMINATION RECORD</b> Substitute for Form PTO-875	Application or Docket Number <b>14/184,396</b>	Filing Date <b>02/19/2014</b>	<input type="checkbox"/> To be Mailed
---	---	----------------------------------	---------------------------------------

ENTITY:     LARGE     SMALL     MICRO

**APPLICATION AS FILED – PART I**

FOR	NUMBER FILED	NUMBER EXTRA	RATE (\$)	FEE (\$)
<input type="checkbox"/> BASIC FEE (37 CFR 1.16(a), (b), or (c))	N/A	N/A	N/A	
<input type="checkbox"/> SEARCH FEE (37 CFR 1.16(k), (l), or (m))	N/A	N/A	N/A	
<input type="checkbox"/> EXAMINATION FEE (37 CFR 1.16(o), (p), or (q))	N/A	N/A	N/A	
TOTAL CLAIMS (37 CFR 1.16(i))	minus 20 =	*	X \$ =	
INDEPENDENT CLAIMS (37 CFR 1.16(h))	minus 3 =	*	X \$ =	
<input type="checkbox"/> APPLICATION SIZE FEE (37 CFR 1.16(s))	If the specification and drawings exceed 100 sheets of paper, the application size fee due is \$310 (\$155 for small entity) for each additional 50 sheets or fraction thereof. See 35 U.S.C. 41(a)(1)(G) and 37 CFR 1.16(s).			
<input type="checkbox"/> MULTIPLE DEPENDENT CLAIM PRESENT (37 CFR 1.16(j))				
* If the difference in column 1 is less than zero, enter "0" in column 2.			TOTAL	

**APPLICATION AS AMENDED – PART II**

	(Column 1)	(Column 2)	(Column 3)	PRESENT EXTRA	RATE (\$)	ADDITIONAL FEE (\$)
<b>AMENDMENT</b>	<b>08/26/2014</b>	CLAIMS REMAINING AFTER AMENDMENT		HIGHEST NUMBER PREVIOUSLY PAID FOR		
		*	Minus	** 24	= 0	X \$80 = 0
		* 21		***3	= 0	X \$420 = 0
		* 2				
	<input type="checkbox"/> Application Size Fee (37 CFR 1.16(s))					
	<input type="checkbox"/> FIRST PRESENTATION OF MULTIPLE DEPENDENT CLAIM (37 CFR 1.16(j))					
					TOTAL ADD'L FEE	<b>0</b>

	(Column 1)	(Column 2)	(Column 3)	PRESENT EXTRA	RATE (\$)	ADDITIONAL FEE (\$)
<b>AMENDMENT</b>		CLAIMS REMAINING AFTER AMENDMENT		HIGHEST NUMBER PREVIOUSLY PAID FOR		
		*	Minus	**	=	X \$ =
		*		***	=	X \$ =
		*				
	<input type="checkbox"/> Application Size Fee (37 CFR 1.16(s))					
	<input type="checkbox"/> FIRST PRESENTATION OF MULTIPLE DEPENDENT CLAIM (37 CFR 1.16(j))					
					TOTAL ADD'L FEE	

\* If the entry in column 1 is less than the entry in column 2, write "0" in column 3.  
 \*\* If the "Highest Number Previously Paid For" IN THIS SPACE is less than 20, enter "20".  
 \*\*\* If the "Highest Number Previously Paid For" IN THIS SPACE is less than 3, enter "3".  
 The "Highest Number Previously Paid For" (Total or Independent) is the highest number found in the appropriate box in column 1.

LIE  
/LINDA HUMES/

This collection of information is required by 37 CFR 1.16. The information is required to obtain or retain a benefit by the public which is to file (and by the USPTO to process) an application. Confidentiality is governed by 35 U.S.C. 122 and 37 CFR 1.14. This collection is estimated to take 12 minutes to complete, including gathering, preparing, and submitting the completed application form to the USPTO. Time will vary depending upon the individual case. Any comments on the amount of time you require to complete this form and/or suggestions for reducing this burden, should be sent to the Chief Information Officer, U.S. Patent and Trademark Office, U.S. Department of Commerce, P.O. Box 1450, Alexandria, VA 22313-1450. DO NOT SEND FEES OR COMPLETED FORMS TO THIS ADDRESS. **SEND TO: Commissioner for Patents, P.O. Box 1450, Alexandria, VA 22313-1450.**

*If you need assistance in completing the form, call 1-800-PTO-9199 and select option 2.*



NOTICE OF ALLOWANCE AND FEE(S) DUE

20792 7590 11/06/2014
MYERS BIGEL SIBLEY & SAJOVEC
PO BOX 37428
RALEIGH, NC 27627

Table with 2 columns: EXAMINER (FULLER, RODNEY EVAN), ART UNIT (2852), PAPER NUMBER

DATE MAILED: 11/06/2014

Table with 5 columns: APPLICATION NO., FILING DATE, FIRST NAMED INVENTOR, ATTORNEY DOCKET NO., CONFIRMATION NO.

TITLE OF INVENTION: METHODS AND APPARATUS FOR GENERATING DATA OUTPUT CONTAINING PHYSIOLOGICAL AND MOTION-RELATED INFORMATION

Table with 7 columns: APPLN. TYPE, ENTITY STATUS, ISSUE FEE DUE, PUBLICATION FEE DUE, PREV. PAID ISSUE FEE, TOTAL FEE(S) DUE, DATE DUE

THE APPLICATION IDENTIFIED ABOVE HAS BEEN EXAMINED AND IS ALLOWED FOR ISSUANCE AS A PATENT. PROSECUTION ON THE MERITS IS CLOSED. THIS NOTICE OF ALLOWANCE IS NOT A GRANT OF PATENT RIGHTS. THIS APPLICATION IS SUBJECT TO WITHDRAWAL FROM ISSUE AT THE INITIATIVE OF THE OFFICE OR UPON PETITION BY THE APPLICANT. SEE 37 CFR 1.313 AND MPEP 1308.

THE ISSUE FEE AND PUBLICATION FEE (IF REQUIRED) MUST BE PAID WITHIN THREE MONTHS FROM THE MAILING DATE OF THIS NOTICE OR THIS APPLICATION SHALL BE REGARDED AS ABANDONED. THIS STATUTORY PERIOD CANNOT BE EXTENDED. SEE 35 U.S.C. 151. THE ISSUE FEE DUE INDICATED ABOVE DOES NOT REFLECT A CREDIT FOR ANY PREVIOUSLY PAID ISSUE FEE IN THIS APPLICATION. IF AN ISSUE FEE HAS PREVIOUSLY BEEN PAID IN THIS APPLICATION (AS SHOWN ABOVE), THE RETURN OF PART B OF THIS FORM WILL BE CONSIDERED A REQUEST TO REAPPLY THE PREVIOUSLY PAID ISSUE FEE TOWARD THE ISSUE FEE NOW DUE.

HOW TO REPLY TO THIS NOTICE:

I. Review the ENTITY STATUS shown above. If the ENTITY STATUS is shown as SMALL or MICRO, verify whether entitlement to that entity status still applies.

If the ENTITY STATUS is the same as shown above, pay the TOTAL FEE(S) DUE shown above.

If the ENTITY STATUS is changed from that shown above, on PART B - FEE(S) TRANSMITTAL, complete section number 5 titled "Change in Entity Status (from status indicated above)".

For purposes of this notice, small entity fees are 1/2 the amount of undiscounted fees, and micro entity fees are 1/2 the amount of small entity fees.

II. PART B - FEE(S) TRANSMITTAL, or its equivalent, must be completed and returned to the United States Patent and Trademark Office (USPTO) with your ISSUE FEE and PUBLICATION FEE (if required). If you are charging the fee(s) to your deposit account, section "4b" of Part B - Fee(s) Transmittal should be completed and an extra copy of the form should be submitted. If an equivalent of Part B is filed, a request to reapply a previously paid issue fee must be clearly made, and delays in processing may occur due to the difficulty in recognizing the paper as an equivalent of Part B.

III. All communications regarding this application must give the application number. Please direct all communications prior to issuance to Mail Stop ISSUE FEE unless advised to the contrary.

IMPORTANT REMINDER: Utility patents issuing on applications filed on or after Dec. 12, 1980 may require payment of maintenance fees. It is patentee's responsibility to ensure timely payment of maintenance fees when due.

**PART B - FEE(S) TRANSMITTAL**

**Complete and send this form, together with applicable fee(s), to: Mail Mail Stop ISSUE FEE  
 Commissioner for Patents  
 P.O. Box 1450  
 Alexandria, Virginia 22313-1450  
 or Fax (571)-273-2885**

**INSTRUCTIONS:** This form should be used for transmitting the ISSUE FEE and PUBLICATION FEE (if required). Blocks 1 through 5 should be completed where appropriate. All further correspondence including the Patent, advance orders and notification of maintenance fees will be mailed to the current correspondence address as indicated unless corrected below or directed otherwise in Block 1, by (a) specifying a new correspondence address; and/or (b) indicating a separate "FEE ADDRESS" for maintenance fee notifications.

CURRENT CORRESPONDENCE ADDRESS (Note: Use Block 1 for any change of address)

Note: A certificate of mailing can only be used for domestic mailings of the Fee(s) Transmittal. This certificate cannot be used for any other accompanying papers. Each additional paper, such as an assignment or formal drawing, must have its own certificate of mailing or transmission.

20792 7590 11/06/2014  
**MYERS BIGEL SIBLEY & SAJOVEC**  
 PO BOX 37428  
 RALEIGH, NC 27627

**Certificate of Mailing or Transmission**

I hereby certify that this Fee(s) Transmittal is being deposited with the United States Postal Service with sufficient postage for first class mail in an envelope addressed to the Mail Stop ISSUE FEE address above, or being facsimile transmitted to the USPTO (571) 273-2885, on the date indicated below.

(Depositor's name)
(Signature)
(Date)

APPLICATION NO.	FILING DATE	FIRST NAMED INVENTOR	ATTORNEY DOCKET NO.	CONFIRMATION NO.
14/184,396	02/19/2014	Steven Francis LeBoeuf	9653-7TSCT2	8272

TITLE OF INVENTION: METHODS AND APPARATUS FOR GENERATING DATA OUTPUT CONTAINING PHYSIOLOGICAL AND MOTION-RELATED INFORMATION

APPLN. TYPE	ENTITY STATUS	ISSUE FEE DUE	PUBLICATION FEE DUE	PREV. PAID ISSUE FEE	TOTAL FEE(S) DUE	DATE DUE
nonprovisional	UNDISCOUNTED	\$960	\$0	\$0	\$960	02/06/2015

EXAMINER	ART UNIT	CLASS-SUBCLASS
FULLER, RODNEY EVAN	2852	600-310000

<p>1. Change of correspondence address or indication of "Fee Address" (37 CFR 1.363).</p> <p><input type="checkbox"/> Change of correspondence address (or Change of Correspondence Address form PTO/SB/122) attached.</p> <p><input type="checkbox"/> "Fee Address" indication (or "Fee Address" Indication form PTO/SB/47; Rev 03-02 or more recent) attached. <b>Use of a Customer Number is required.</b></p>	<p>2. For printing on the patent front page, list</p> <p>(1) The names of up to 3 registered patent attorneys or agents OR, alternatively, _____ 1</p> <p>(2) The name of a single firm (having as a member a registered attorney or agent) and the names of up to 2 registered patent attorneys or agents. If no name is listed, no name will be printed. _____ 2</p> <p>_____ 3</p>
---	---

**3. ASSIGNEE NAME AND RESIDENCE DATA TO BE PRINTED ON THE PATENT (print or type)**

PLEASE NOTE: Unless an assignee is identified below, no assignee data will appear on the patent. If an assignee is identified below, the document has been filed for recordation as set forth in 37 CFR 3.11. Completion of this form is NOT a substitute for filing an assignment.

(A) NAME OF ASSIGNEE \_\_\_\_\_ (B) RESIDENCE: (CITY and STATE OR COUNTRY) \_\_\_\_\_

Please check the appropriate assignee category or categories (will not be printed on the patent) :  Individual  Corporation or other private group entity  Government

<p>4a. The following fee(s) are submitted:</p> <p><input type="checkbox"/> Issue Fee</p> <p><input type="checkbox"/> Publication Fee (No small entity discount permitted)</p> <p><input type="checkbox"/> Advance Order - # of Copies _____</p>	<p>4b. Payment of Fee(s): (<b>Please first reapply any previously paid issue fee shown above</b>)</p> <p><input type="checkbox"/> A check is enclosed.</p> <p><input type="checkbox"/> Payment by credit card. Form PTO-2038 is attached.</p> <p><input type="checkbox"/> The Director is hereby authorized to charge the required fee(s), any deficiency, or credits any overpayment, to Deposit Account Number _____ (enclose an extra copy of this form).</p>
---	--

**5. Change in Entity Status** (from status indicated above)

Applicant certifying micro entity status. See 37 CFR 1.29

Applicant asserting small entity status. See 37 CFR 1.27

Applicant changing to regular undiscouted fee status.

**NOTE:** Absent a valid certification of Micro Entity Status (see forms PTO/SB/15A and 15B), issue fee payment in the micro entity amount will not be accepted at the risk of application abandonment.

**NOTE:** If the application was previously under micro entity status, checking this box will be taken to be a notification of loss of entitlement to micro entity status.

**NOTE:** Checking this box will be taken to be a notification of loss of entitlement to small or micro entity status, as applicable.

**NOTE:** This form must be signed in accordance with 37 CFR 1.31 and 1.33. See 37 CFR 1.4 for signature requirements and certifications.

Authorized Signature \_\_\_\_\_ Date \_\_\_\_\_

Typed or printed name \_\_\_\_\_ Registration No. \_\_\_\_\_





UNITED STATES PATENT AND TRADEMARK OFFICE

UNITED STATES DEPARTMENT OF COMMERCE
United States Patent and Trademark Office
Address: COMMISSIONER FOR PATENTS
P.O. Box 1450
Alexandria, Virginia 22313-1450
www.uspto.gov

Table with 5 columns: APPLICATION NO., FILING DATE, FIRST NAMED INVENTOR, ATTORNEY DOCKET NO., CONFIRMATION NO.
14/184,396 02/19/2014 Steven Francis LeBoeuf 9653-7TSCT2 8272

20792 7590 11/06/2014
MYERS BIGEL SIBLEY & SAJOVEC
PO BOX 37428
RALEIGH, NC 27627

EXAMINER

FULLER, RODNEY EVAN

ART UNIT PAPER NUMBER

2852

DATE MAILED: 11/06/2014

Determination of Patent Term Adjustment under 35 U.S.C. 154 (b)
(Applications filed on or after May 29, 2000)

The Office has discontinued providing a Patent Term Adjustment (PTA) calculation with the Notice of Allowance.

Section 1(h)(2) of the AIA Technical Corrections Act amended 35 U.S.C. 154(b)(3)(B)(i) to eliminate the requirement that the Office provide a patent term adjustment determination with the notice of allowance. See Revisions to Patent Term Adjustment, 78 Fed. Reg. 19416, 19417 (Apr. 1, 2013). Therefore, the Office is no longer providing an initial patent term adjustment determination with the notice of allowance. The Office will continue to provide a patent term adjustment determination with the Issue Notification Letter that is mailed to applicant approximately three weeks prior to the issue date of the patent, and will include the patent term adjustment on the patent. Any request for reconsideration of the patent term adjustment determination (or reinstatement of patent term adjustment) should follow the process outlined in 37 CFR 1.705.

Any questions regarding the Patent Term Extension or Adjustment determination should be directed to the Office of Patent Legal Administration at (571)-272-7702. Questions relating to issue and publication fee payments should be directed to the Customer Service Center of the Office of Patent Publication at 1-(888)-786-0101 or (571)-272-4200.

## OMB Clearance and PRA Burden Statement for PTOL-85 Part B

The Paperwork Reduction Act (PRA) of 1995 requires Federal agencies to obtain Office of Management and Budget approval before requesting most types of information from the public. When OMB approves an agency request to collect information from the public, OMB (i) provides a valid OMB Control Number and expiration date for the agency to display on the instrument that will be used to collect the information and (ii) requires the agency to inform the public about the OMB Control Number's legal significance in accordance with 5 CFR 1320.5(b).

The information collected by PTOL-85 Part B is required by 37 CFR 1.311. The information is required to obtain or retain a benefit by the public which is to file (and by the USPTO to process) an application. Confidentiality is governed by 35 U.S.C. 122 and 37 CFR 1.14. This collection is estimated to take 12 minutes to complete, including gathering, preparing, and submitting the completed application form to the USPTO. Time will vary depending upon the individual case. Any comments on the amount of time you require to complete this form and/or suggestions for reducing this burden, should be sent to the Chief Information Officer, U.S. Patent and Trademark Office, U.S. Department of Commerce, P.O. Box 1450, Alexandria, Virginia 22313-1450. DO NOT SEND FEES OR COMPLETED FORMS TO THIS ADDRESS. SEND TO: Commissioner for Patents, P.O. Box 1450, Alexandria, Virginia 22313-1450. Under the Paperwork Reduction Act of 1995, no persons are required to respond to a collection of information unless it displays a valid OMB control number.

### Privacy Act Statement

**The Privacy Act of 1974 (P.L. 93-579)** requires that you be given certain information in connection with your submission of the attached form related to a patent application or patent. Accordingly, pursuant to the requirements of the Act, please be advised that: (1) the general authority for the collection of this information is 35 U.S.C. 2(b)(2); (2) furnishing of the information solicited is voluntary; and (3) the principal purpose for which the information is used by the U.S. Patent and Trademark Office is to process and/or examine your submission related to a patent application or patent. If you do not furnish the requested information, the U.S. Patent and Trademark Office may not be able to process and/or examine your submission, which may result in termination of proceedings or abandonment of the application or expiration of the patent.

The information provided by you in this form will be subject to the following routine uses:

1. The information on this form will be treated confidentially to the extent allowed under the Freedom of Information Act (5 U.S.C. 552) and the Privacy Act (5 U.S.C. 552a). Records from this system of records may be disclosed to the Department of Justice to determine whether disclosure of these records is required by the Freedom of Information Act.
2. A record from this system of records may be disclosed, as a routine use, in the course of presenting evidence to a court, magistrate, or administrative tribunal, including disclosures to opposing counsel in the course of settlement negotiations.
3. A record in this system of records may be disclosed, as a routine use, to a Member of Congress submitting a request involving an individual, to whom the record pertains, when the individual has requested assistance from the Member with respect to the subject matter of the record.
4. A record in this system of records may be disclosed, as a routine use, to a contractor of the Agency having need for the information in order to perform a contract. Recipients of information shall be required to comply with the requirements of the Privacy Act of 1974, as amended, pursuant to 5 U.S.C. 552a(m).
5. A record related to an International Application filed under the Patent Cooperation Treaty in this system of records may be disclosed, as a routine use, to the International Bureau of the World Intellectual Property Organization, pursuant to the Patent Cooperation Treaty.
6. A record in this system of records may be disclosed, as a routine use, to another federal agency for purposes of National Security review (35 U.S.C. 181) and for review pursuant to the Atomic Energy Act (42 U.S.C. 218(c)).
7. A record from this system of records may be disclosed, as a routine use, to the Administrator, General Services, or his/her designee, during an inspection of records conducted by GSA as part of that agency's responsibility to recommend improvements in records management practices and programs, under authority of 44 U.S.C. 2904 and 2906. Such disclosure shall be made in accordance with the GSA regulations governing inspection of records for this purpose, and any other relevant (i.e., GSA or Commerce) directive. Such disclosure shall not be used to make determinations about individuals.
8. A record from this system of records may be disclosed, as a routine use, to the public after either publication of the application pursuant to 35 U.S.C. 122(b) or issuance of a patent pursuant to 35 U.S.C. 151. Further, a record may be disclosed, subject to the limitations of 37 CFR 1.14, as a routine use, to the public if the record was filed in an application which became abandoned or in which the proceedings were terminated and which application is referenced by either a published application, an application open to public inspection or an issued patent.
9. A record from this system of records may be disclosed, as a routine use, to a Federal, State, or local law enforcement agency, if the USPTO becomes aware of a violation or potential violation of law or regulation.

<b>Notice of Allowability</b>	<b>Application No.</b> 14/184,396	<b>Applicant(s)</b> LEBOEUF ET AL.	
	<b>Examiner</b> RODNEY FULLER	<b>Art Unit</b> 2852	<b>AIA (First Inventor to File) Status</b> No

**-- The MAILING DATE of this communication appears on the cover sheet with the correspondence address--**

All claims being allowable, PROSECUTION ON THE MERITS IS (OR REMAINS) CLOSED in this application. If not included herewith (or previously mailed), a Notice of Allowance (PTOL-85) or other appropriate communication will be mailed in due course. **THIS NOTICE OF ALLOWABILITY IS NOT A GRANT OF PATENT RIGHTS.** This application is subject to withdrawal from issue at the initiative of the Office or upon petition by the applicant. See 37 CFR 1.313 and MPEP 1308.

1.  This communication is responsive to applicant's Amendment, dated 08/26/2014.  
 A declaration(s)/affidavit(s) under **37 CFR 1.130(b)** was/were filed on \_\_\_\_\_.
2.  An election was made by the applicant in response to a restriction requirement set forth during the interview on \_\_\_\_\_; the restriction requirement and election have been incorporated into this action.
3.  The allowed claim(s) is/are 1,3-18 and 21-24. As a result of the allowed claim(s), you may be eligible to benefit from the **Patent Prosecution Highway** program at a participating intellectual property office for the corresponding application. For more information, please see [http://www.uspto.gov/patents/init\\_events/oph/index.jsp](http://www.uspto.gov/patents/init_events/oph/index.jsp) or send an inquiry to [PPHfeedback@uspto.gov](mailto:PPHfeedback@uspto.gov).
4.  Acknowledgment is made of a claim for foreign priority under 35 U.S.C. § 119(a)-(d) or (f).

**Certified copies:**

- a)  All    b)  Some    \*c)  None of the:
1.  Certified copies of the priority documents have been received.
  2.  Certified copies of the priority documents have been received in Application No. \_\_\_\_\_.
  3.  Copies of the certified copies of the priority documents have been received in this national stage application from the International Bureau (PCT Rule 17.2(a)).

\* Certified copies not received: \_\_\_\_\_.

Applicant has THREE MONTHS FROM THE "MAILING DATE" of this communication to file a reply complying with the requirements noted below. Failure to timely comply will result in ABANDONMENT of this application.

**THIS THREE-MONTH PERIOD IS NOT EXTENDABLE.**

5.  CORRECTED DRAWINGS ( as "replacement sheets") must be submitted.  
 including changes required by the attached Examiner's Amendment / Comment or in the Office action of Paper No./Mail Date \_\_\_\_\_.  
**Identifying indicia such as the application number (see 37 CFR 1.84(c)) should be written on the drawings in the front (not the back) of each sheet. Replacement sheet(s) should be labeled as such in the header according to 37 CFR 1.121(d).**
6.  DEPOSIT OF and/or INFORMATION about the deposit of BIOLOGICAL MATERIAL must be submitted. Note the attached Examiner's comment regarding REQUIREMENT FOR THE DEPOSIT OF BIOLOGICAL MATERIAL.

**Attachment(s)**

- |  |   |
|--|---|
| <ol style="list-style-type: none"> <li>1. <input type="checkbox"/> Notice of References Cited (PTO-892)</li> <li>2. <input checked="" type="checkbox"/> Information Disclosure Statements (PTO/SB/08),<br/>Paper No./Mail Date <u>8/26/2014</u></li> <li>3. <input type="checkbox"/> Examiner's Comment Regarding Requirement for Deposit of Biological Material</li> <li>4. <input type="checkbox"/> Interview Summary (PTO-413),<br/>Paper No./Mail Date _____.</li> </ol> | <ol style="list-style-type: none"> <li>5. <input type="checkbox"/> Examiner's Amendment/Comment</li> <li>6. <input type="checkbox"/> Examiner's Statement of Reasons for Allowance</li> <li>7. <input checked="" type="checkbox"/> Other <u>Detailed Action.</u></li> </ol> |
|--|---|

/RODNEY FULLER/  
Primary Examiner, Art Unit 2852

### **DETAILED ACTION**

1. The present application is being examined under the pre-AIA first to invent provisions.

#### ***Terminal Disclaimer***

2. The terminal disclaimers filed on 08/26/2014 disclaiming the terminal portion of any patent granted on this application which would extend beyond the expiration date of U.S. Patent No. 8,700,111 and any patent granted on Application Number 14/194,891 have been reviewed and are accepted. The terminal disclaimers have been recorded.

#### ***Allowable Subject Matter***

3. Claims 1, 3-18 and 21-24 are allowed.

#### ***Conclusion***

4. Any inquiry concerning this communication or earlier communications from the examiner should be directed to RODNEY FULLER whose telephone number is (571)272-2118. The examiner can normally be reached on 8:00am - 4:30pm.

If attempts to reach the examiner by telephone are unsuccessful, the examiner's supervisor, Clayton Laballe can be reached on 571-272-1594. The fax phone number for the organization where this application or proceeding is assigned is 571-273-8300.

Art Unit: 2852

Information regarding the status of an application may be obtained from the Patent Application Information Retrieval (PAIR) system. Status information for published applications may be obtained from either Private PAIR or Public PAIR. Status information for unpublished applications is available through Private PAIR only. For more information about the PAIR system, see <http://pair-direct.uspto.gov>. Should you have questions on access to the Private PAIR system, contact the Electronic Business Center (EBC) at 866-217-9197 (toll-free). If you would like assistance from a USPTO Customer Service Representative or access to the automated information system, call 800-786-9199 (IN USA OR CANADA) or 571-272-1000.

/RODNEY FULLER/  
Primary Examiner, Art Unit 2852

October 26, 2014

<b>INFORMATION DISCLOSURE STATEMENT BY APPLICANT</b>  <i>(use as many sheets as necessary)</i>				<i>Complete if Known</i>	
				Application Number	14/184,396
				Filing Date	02-19-2014
				First Named Inventor	Steven Francis LeBoeuf
				Art Unit	2852
				Examiner Name	Rodney Evan Fuller
Sheet <b>E1</b>	of	<b>E1</b>	Attorney Docket Number	9653-7TST2	

U.S. PATENT DOCUMENTS					
Examiner Initials*	Cite No.	Document Number	Publication Date MM-DD-YYYY	Name of Patentee or Applicant of Cited Document	Pages, Columns, Lines, Where Relevant Passages or Relevant Figures Appear
		Number-Kind Code (if known)			
	1.	US- 2012/0179011 A1	07-12-2012	Moon et al.	
	2.	US- 7,107,088 B2	09-12-2006	Aceti	
	3.	US- 2003/0109030 A1	06-12-2003	Uchida et al.	
	4.	US- 6,358,216 B1	03-19-2002	Kraus et al.	
		US-			
		US-			
		US-			
		US-			
		US-			
		US-			
		US-			
		US-			
		US-			

FOREIGN PATENT DOCUMENTS						
Examiner Initials*	Cite No.	Foreign Patent Document	Publication Date MM-DD-YYYY	Name of Patentee or Applicant of Cited Document	Pages, Columns, Lines, Where Relevant Passages or Relevant Figures Appear	T
		Country Code, Number, Kind Code (if known)				
	5.	EP 2 077 091 A2	07-08-2009	Perception Digital Limited		

NON PATENT LITERATURE DOCUMENTS			
Examiner Initials*	Cite No.	Include name of the author (in CAPITAL LETTERS), title of the article (when appropriate), title of the item (book, magazine, journal, serial, symposium, catalog, etc.), date, page(s), volume-issue number(s), publisher, city and/or country where published	T

ALL REFERENCES CONSIDERED EXCEPT WHERE LINED THROUGH. /RF/

Examiner Signature	/Rodney Fuller/	Date Considered	10/26/2014
--------------------	-----------------	-----------------	------------

\*EXAMINER: Initial if reference considered, whether or not citation is in conformance with MPEP 609. Draw line through citation if not in conformance and not considered. Include copy of this form with next communication to applicant.

## EAST Search History

## EAST Search History (Prior Art)

Ref #	Hits	Search Query	DBs	Default Operator	Plurals	Time Stamp
L1	1	("8700111").PN.	US-PGPUB; USPAT; USOCR	OR	OFF	2014/10/26 12:31
L2	2	((("20090287067") or ("20080177162")).PN.	US-PGPUB; USPAT; USOCR	OR	OFF	2014/10/26 12:46
L3	39	("20090287067"   "20100298653"   "6078829"   "20060009685"   "20120197093"   "5086229"   "6371925"   "6859658"   "20020091049"   "20050209516"   "20080177162"   "20090105556"   "20100168531"   "6080110"   "20040225207"   "6783501"   "20090030350"   "5596987"   "6358216"   "7107088"   "20090270698"   "20110105869"   "20130131519"   "7209775"   "8512242"   "20040034293"   "20050043600"   "20050177034"   "20050228299"   "20080096726"   "20080165017"   "20090054752"   "6808473"   "8251903"   "20040054291"   "20100217103"   "20120179011"   "8055319"   "20030109030").PN.	US-PGPUB; USPAT; USOCR	OR	ON	2014/10/26 12:50
L4	1	("7107008").PN.	US-PGPUB; USPAT; USOCR	OR	OFF	2014/10/26 12:52
L5	1	("7107088").PN.	US-PGPUB; USPAT; USOCR	OR	OFF	2014/10/26 12:52
L6	1	5 and motion	US-PGPUB; USPAT; USOCR; FPRS; EPO; JPO; DERWENT; IBM_TDB	OR	ON	2014/10/26 12:52
L7	1	1 and serial	US-PGPUB; USPAT; USOCR; FPRS; EPO; JPO; DERWENT; IBM_TDB	OR	ON	2014/10/26 12:56
L8	14	("20100217103"   "20100298653"   "5086229"   "20040054291"   "20100168531"   "20040225207"   "5596987"   "6358216"   "7107088"   "20040034293"   "20090287067"   "20050043600"   "20120179011"   "20030109030").PN.	US-PGPUB; USPAT; USOCR	OR	ON	2014/10/26 12:57

L9	39	8 or 3	US-PGPUB; USPAT; USOCR	OR	ON	2014/10/26 12:57
L10	6	9 and (motion and serial)	US-PGPUB; USPAT; USOCR	OR	ON	2014/10/26 12:57
L11	6	((("20130131519") or ("20120179011") or ("20100298653") or ("20050228299") or ("20040034293") or ("8055319")).PN.	US-PGPUB; USPAT; USOCR	OR	OFF	2014/10/26 12:58
L12	6	11 and serial	US-PGPUB; USPAT; USOCR; FPRS; EPO; JPO; DERWENT; IBM_TDB	OR	ON	2014/10/26 12:58
L13	4685	((600/310) or (600/322) or (600/323) or (600/324)).CCLS.	US-PGPUB; USPAT; USOCR	OR	OFF	2014/10/26 12:59
L14	508	13 and (serial with data)	US-PGPUB; USPAT; USOCR; FPRS; EPO; JPO; DERWENT; IBM_TDB	OR	ON	2014/10/26 13:00
L15	1762	13 and motion	US-PGPUB; USPAT; USOCR; FPRS; EPO; JPO; DERWENT; IBM_TDB	OR	ON	2014/10/26 13:00
L16	1201	15 and (oximetry)	US-PGPUB; USPAT; USOCR; FPRS; EPO; JPO; DERWENT; IBM_TDB	OR	ON	2014/10/26 13:00
L17	570	16 and window	US-PGPUB; USPAT; USOCR; FPRS; EPO; JPO; DERWENT; IBM_TDB	OR	ON	2014/10/26 13:00
L18	343	17 and (motion with artifacts)	US-PGPUB; USPAT; USOCR; FPRS; EPO; JPO; DERWENT; IBM_TDB	OR	ON	2014/10/26 13:00
L19	233	13 and (respiration with heart with rate)	US-PGPUB; USPAT; USOCR; FPRS; EPO; JPO; DERWENT;	OR	ON	2014/10/26 13:12



			IBM_TDB			
L20	59	19 and serial	US-PGPUB; USPAT; USOCR; FPRS; EPO; JPO; DERWENT; IBM_TDB	OR	ON	2014/10/26 13:12
S1	4	((("20100217103") or ("20040225207") or ("20040054291") or ("20040034293")).PN.	US-PGPUB; USPAT; USOCR	OR	OFF	2014/10/24 15:13
S2	1	S1 and concha	US-PGPUB; USPAT; USOCR; FPRS; EPO; JPO; DERWENT; IBM_TDB	OR	ON	2014/10/24 15:15
S3	39	("20050228299"   "20090287067"   "20100298653"   "6078829"   "20120197093"   "5086229"   "6080110"   "6371925"   "6859658"   "20080177162"   "20090105556"   "20100168531"   "20080076972"   "20090030350"   "5596987"   "6783501"   "20090054752"   "6358216"   "7107088"   "20060009685"   "20090270698"   "20110105869"   "20130131519"   "7209775"   "8512242"   "8055319"   "20050043600"   "20050177034"   "20050209516"   "20080096726"   "20080165017"   "20090054752"   "6808473"   "8251903"   "20040034293"   "20120179011"   "20040054291"   "20100217103"   "8055319"   "20030109030"   "20040225207").PN.	US-PGPUB; USPAT; USOCR	OR	ON	2014/10/24 15:32
S4	39	("20050228299"   "6371925"   "7209775"   "20100298653"   "20080165017"   "20090105556"   "20110105869"   "20120197093"   "8055319"   "5086229"   "20050177034"   "8251903"   "20100168531"   "20040225207"   "20080076972"   "20080096726"   "20080177162"   "6078829"   "6783501"   "6808473"   "5596987"   "6358216"   "7107088"   "20060009685"   "20090054752"   "20130131519"   "6859658"   "20050209516"   "20090030350"   "20090270698"   "8512242"   "20050043600"   "20040034293"   "20090287067"   "6080110"   "20040054291"   "20100217103"   "20080177162"   "20030109030"   "20120179011").PN.	US-PGPUB; USPAT; USOCR	OR	ON	2014/10/24 15:33
S5	14	("20100217103"   "20100298653"   "5086229"   "7107088"   "20040054291"   "20100168531"   "20090054752"   "5596987"   "20040034293"   "20060009685"   "20050043600"   "20120179011"   "20030109030"	US-PGPUB; USPAT; USOCR	OR	ON	2014/10/24 15:33

		"6358215").PN.				
S6	39	("20090287067"   "20100298653"   "6078829"   "20060009685"   "20120197093"   "5086229"   "6371925"   "6859658"   "20050209516"   "20080177162"   "20090105556"   "20100168531"   "6080110"   "20080076972"   "20090030350"   "5596987"   "6358216"   "7107088"   "6783501"   "20090270698"   "20110105869"   "20130131519"   "7209775"   "8512242"   "20040034293"   "20050043600"   "20050177034"   "20050228299"   "20080096726"   "20090054752"   "6808473"   "8251903"   "20040054291"   "20100217103"   "20080162017"   "8055319"   "20030109030"   "20040225207"   "20120179011").PN.	US-PGPUB; USPAT; USOCR	OR	ON	2014/10/24 15:33
S7	1	"14298219"	US-PGPUB; USPAT; USOCR	OR	ON	2014/10/24 15:33
S8	39	("20090287067"   "20100298653"   "6078829"   "20060009685"   "20120197093"   "5086229"   "6371925"   "6859658"   "20020091049"   "20050209516"   "20080177162"   "20090105556"   "20100168531"   "6080110"   "20040225207"   "6783501"   "20090030350"   "5596987"   "6358216"   "7107088"   "20090270698"   "20110105869"   "20130131519"   "7209775"   "8512242"   "20040034293"   "20050043600"   "20050177034"   "20050228299"   "20080096726"   "20080165017"   "20090054752"   "6808473"   "8251903"   "20040054291"   "20100217103"   "20120179011"   "8055319"   "20030109030").PN.	US-PGPUB; USPAT; USOCR	OR	ON	2014/10/24 15:34
S9	2	((("8700111") or ("8788002"))).PN.	US-PGPUB; USPAT; USOCR	OR	OFF	2014/10/24 15:34
S10	33	("20040034293"   "20040054291"   "20050043600"   "20050177034"   "20050209516"   "20050228299"   "20060009685"   "20080076972"   "20080096726"   "20080165017"   "20080177162"   "20090030350"   "20090054752"   "20090105556"   "20090270698"   "20090287067"   "20100168531"   "20100217103"   "20100298653"   "20110105869"   "20120197093"   "20130131519"   "5086229"   "5596987"   "6078829"   "6080110"   "6371925"   "6808473"   "6859658"   "7209775"   "8055319"   "8251903"   "8512242").PN. OR ("8788002").URPN.	US-PGPUB; USPAT; USOCR	OR	ON	2014/10/24 15:34
S11	26	("20050177034"   "20050209516"   "20050228299"   "20060009685"   "20080076972"   "20080096726"   "20080165017"   "20080177162"	US-PGPUB; USPAT; USOCR	OR	ON	2014/10/24 15:34

		"20090030350"   "20090054752"   "20090105556"   "20090270698"   "20090287067"   "20110105869"   "20120197093"   "20130131519"   "6078829"   "6080110"   "6371925"   "6783501"   "6808473"   "6859658"   "7209775"   "8055319"   "8251903"   "8512242").PN. OR ("8700111").URPN.				
S12	45	S1 or S2 or S3 or S4 or S5 or S6 or S7 or S8 or S9 or S10 or S11	US-PGPUB; USPAT; USOCR	OR	ON	2014/10/24 15:35
S13	4686	((600/310) or (600/322) or (600/323) or (600/324)).CCLS.	US-PGPUB; USPAT; USOCR	OR	OFF	2014/10/24 15:38
S14	1505	S13 and (ear or earbud)	US-PGPUB; USPAT; USOCR; FPRS; EPO; JPO; DERWENT; IBM_TDB	OR	ON	2014/10/24 15:39
S15	20	S14 and (concha)	US-PGPUB; USPAT; USOCR; FPRS; EPO; JPO; DERWENT; IBM_TDB	OR	ON	2014/10/24 15:39
S16	1505	S14 and ear	US-PGPUB; USPAT; USOCR; FPRS; EPO; JPO; DERWENT; IBM_TDB	OR	ON	2014/10/24 15:40
S17	106	S16 and concentric	US-PGPUB; USPAT; USOCR; FPRS; EPO; JPO; DERWENT; IBM_TDB	OR	ON	2014/10/24 15:40
S18	280	S13 and concentric	US-PGPUB; USPAT; USOCR; FPRS; EPO; JPO; DERWENT; IBM_TDB	OR	ON	2014/10/24 15:40
S19	14	S18 and cladding	US-PGPUB; USPAT; USOCR; FPRS; EPO; JPO; DERWENT; IBM_TDB	OR	ON	2014/10/24 15:40
S20	27	S16 and cladding	US-PGPUB; USPAT; USOCR; FPRS; EPO; JPO;	OR	ON	2014/10/24 15:41

			DERWENT; IBM_TDB			
S21	20	S20 and adhesive	US-PGPUB; USPAT; USOCR; FPRS; EPO; JPO; DERWENT; IBM_TDB	OR	ON	2014/10/24 15:41
S22	339	(light or emitter) and (sensor or detector) and ear and concha	US-PGPUB; USPAT; USOCR; FPRS; EPO; JPO; DERWENT; IBM_TDB	OR	ON	2014/10/24 15:43
S23	631696	ear or earbud	US-PGPUB; USPAT; USOCR; FPRS; EPO; JPO; DERWENT; IBM_TDB	OR	ON	2014/10/24 15:45
S24	3236	S23 and concha	US-PGPUB; USPAT; USOCR; FPRS; EPO; JPO; DERWENT; IBM_TDB	OR	ON	2014/10/24 15:45
S25	502	S24 and (antitragus or anti-tragus or (anti adj tragus))	US-PGPUB; USPAT; USOCR; FPRS; EPO; JPO; DERWENT; IBM_TDB	OR	ON	2014/10/24 15:45
S26	165	S25 and (emitter or light)	US-PGPUB; USPAT; USOCR; FPRS; EPO; JPO; DERWENT; IBM_TDB	OR	ON	2014/10/24 15:45
S27	79	S26 and (detector or sensor)	US-PGPUB; USPAT; USOCR; FPRS; EPO; JPO; DERWENT; IBM_TDB	OR	ON	2014/10/24 15:45
S28	25	S27 and (window or aperture)	US-PGPUB; USPAT; USOCR; FPRS; EPO; JPO; DERWENT; IBM_TDB	OR	ON	2014/10/24 16:02

**EAST Search History (Interference)**

Ref #	Hits	Search Query	DBs	Default Operator	Plurals	Time Stamp
L21	0	(motion and (sensor or detector) and (pysiological or photoplethysmography or ppg) and serial and data and heart and rate and respiration).clm.	USPAT; UPAD	OR	ON	2014/10/26 13:18
L22	0	(housing and ppg and motion and artifact and window).clm.	USPAT; UPAD	OR	ON	2014/10/26 13:19

**10/26/2014 1:20:02 PM**

**C:\Users\rfuller\Documents\EAST\Workspaces\rodney9.wsp**

<b>Issue Classification</b> 	<b>Application/Control No.</b> 14184396	<b>Applicant(s)/Patent Under Reexamination</b> LEBOEUF ET AL.
	<b>Examiner</b> RODNEY FULLER	<b>Art Unit</b> 2852

CPC						
Symbol					Type	Version
A61B		5		4812	F	2013-01-01
A61B		5		00	I	2013-01-01
A61B		5		6815	I	2013-01-01
A61B		5		6838	I	2013-01-01
H04R		1		1091	I	2013-01-01
A61B		5		02055	I	2013-01-01
A61B		5		6803	I	2013-01-01
H04R		1		105	I	2013-01-01
A61B		5		1118	I	2013-01-01
A61B		5		1455	I	2013-01-01
A61B		5		721	I	2013-01-01
A61B		5		0082	I	2013-01-01
A61B		5		0059	I	2013-01-01
A61B		5		0476	I	2013-01-01
A61B		5		14551	I	2013-01-01
A61B		5		165	I	2013-01-01
A61B		5		4848	I	2013-01-01
A61B		5		4866	I	2013-01-01
A61B		5		0013	I	2013-01-01
A61B		5		0084	I	2013-01-01
A61B		5		11	I	2013-01-01
A61B		5		7214	I	2013-01-01
A61B		5		411	A	2013-01-01
A61B		5		415	A	2013-01-01
A61B		5		418	A	2013-01-01
A61B		2560		0242	A	2013-01-01

CPC Combination Sets				
Symbol	Type	Set	Ranking	Version

NONE	<b>Total Claims Allowed:</b>		
(Assistant Examiner)	(Date)	21	
/RODNEY FULLER/ Primary Examiner. Art Unit 2852	10/26/2014	O.G. Print Claim(s)	O.G. Print Figure
(Primary Examiner)	(Date)	1	1

<b>Issue Classification</b> 	<b>Application/Control No.</b> 14184396	<b>Applicant(s)/Patent Under Reexamination</b> LEBOEUF ET AL.
	<b>Examiner</b> RODNEY FULLER	<b>Art Unit</b> 2852

--	--	--	--	--	--

NONE		<b>Total Claims Allowed:</b>	
(Assistant Examiner)	(Date)	21	
/RODNEY FULLER/ Primary Examiner. Art Unit 2852	10/26/2014	O.G. Print Claim(s)	O.G. Print Figure
(Primary Examiner)	(Date)	1	1





<b>Issue Classification</b> 	<b>Application/Control No.</b> 14184396	<b>Applicant(s)/Patent Under Reexamination</b> LEBOEUF ET AL.
	<b>Examiner</b> RODNEY FULLER	<b>Art Unit</b> 2852

<input type="checkbox"/> <b>Claims renumbered in the same order as presented by applicant</b>																<input type="checkbox"/> <b>CPA</b>		<input type="checkbox"/> <b>T.D.</b>		<input type="checkbox"/> <b>R.1.47</b>	
Final	Original	Final	Original	Final	Original	Final	Original	Final	Original	Final	Original	Final	Original	Final	Original						
1	1	16	17																		
-	2	17	18																		
2	3	-	19																		
3	4	-	20																		
4	5	18	21																		
5	6	20	22																		
6	7	19	23																		
7	8	21	24																		
8	9																				
9	10																				
10	11																				
11	12																				
12	13																				
13	14																				
14	15																				
15	16																				

NONE		<b>Total Claims Allowed:</b>	
		21	
(Assistant Examiner)	(Date)	O.G. Print Claim(s)	O.G. Print Figure
/RODNEY FULLER/ Primary Examiner. Art Unit 2852	10/26/2014	1	1
(Primary Examiner)	(Date)		

<b>Search Notes</b>  	<b>Application/Control No.</b>  14184396	<b>Applicant(s)/Patent Under Reexamination</b>  LEBOEUF ET AL.
	<b>Examiner</b>  RODNEY FULLER	<b>Art Unit</b>  2852

CPC- SEARCHED		
Symbol	Date	Examiner

CPC COMBINATION SETS - SEARCHED		
Symbol	Date	Examiner

US CLASSIFICATION SEARCHED			
Class	Subclass	Date	Examiner
600	310	10/26/2014	/RF/

SEARCH NOTES		
Search Notes	Date	Examiner
East text search history printout	10/26/2014	/RF/

INTERFERENCE SEARCH			
US Class/ CPC Symbol	US Subclass / CPC Group	Date	Examiner
	Interference search history printout	10/26/2014	/RF/

	/RODNEY FULLER/ Primary Examiner.Art Unit 2852
--	---

OK TO ENTER: /RF/

In re: LeBoeuf et al.  
Serial No. 14/184,396  
Filed: February 19, 2014  
Page 2

**In the Specification:**

On page 1, line 1, please amend the RELATED APPLICATIONS section as follows:

RELATED APPLICATIONS

This application is a continuation application of pending U.S. Patent Application Serial No. 12/691,388, filed January 21, 2010, now U.S. Patent No. 8,700,111, which claims the benefit of and priority to U.S. Provisional Patent Application No. 61/208,567 filed 02/25/2009, U.S. Provisional Patent Application No. 61/208,574 filed 02/25/2009, U.S. Provisional Patent Application No. 61/212,444 filed 4/13/2009, and U.S. Provisional Patent Application No. 61/274,191 filed 8/14/2009, the disclosures of which are incorporated herein by reference as if set forth in their entireties.

Please amend the paragraph beginning on page 5, line 1 of the specification as follows:

-- In some embodiments, an earbud includes at least one lens in optical communication with the light transmissive material. Each lens may be configured to focus light from the optical emitter onto one or more predetermined locations in the ear of a subject and/or to focus collected external light onto the optical detector. --

Please amend the paragraph beginning on page 10, line 21 of the specification as follows:

-- Fig. 6 is a side section view of a light-guiding earbud for a headset, according to some embodiments of the present invention. [[.]] --

**PART B - FEE(S) TRANSMITTAL**

Complete and send this form, together with applicable fee(s), to: **Mail** **Mail Stop ISSUE FEE**  
**Commissioner for Patents**  
**P.O. Box 1450**  
**Alexandria, Virginia 22313-1450**  
 or **Fax** **(571)-273-2885**

**INSTRUCTIONS:** This form should be used for transmitting the ISSUE FEE and PUBLICATION FEE (if required). Blocks 1 through 5 should be completed where appropriate. All further correspondence including the Patent, advance orders and notification of maintenance fees will be mailed to the current correspondence address as indicated unless corrected below or directed otherwise in Block 1, by (a) specifying a new correspondence address; and/or (b) indicating a separate "FEE ADDRESS" for maintenance fee notifications.

CURRENT CORRESPONDENCE ADDRESS (Note: Use Block 1 for any change of address)

20792 7590 11/06/2014  
**MYERS BIGEL SIBLEY & SAJOVEC**  
**PO BOX 37428**  
**RALEIGH, NC 27627**

Note: A certificate of mailing can only be used for domestic mailings of the Fee(s) Transmittal. This certificate cannot be used for any other accompanying papers. Each additional paper, such as an assignment or formal drawing, must have its own certificate of mailing or transmission.

**Certificate of Mailing or Transmission**

I hereby certify that this Fee(s) Transmittal is being deposited with the United States Postal Service with sufficient postage for first class mail in an envelope addressed to the Mail Stop ISSUE FEE address above, or being facsimile transmitted to the USPTO (571) 273-2885, on the date indicated below.

_____ (Depositor's name)
_____ (Signature)
_____ (Date)

APPLICATION NO.	FILING DATE	FIRST NAMED INVENTOR	ATTORNEY DOCKET NO.	CONFIRMATION NO.
14/184,396	02/19/2014	Steven Francis LeBoeuf	9653-7TSC72	8272

TITLE OF INVENTION: METHODS AND APPARATUS FOR GENERATING DATA OUTPUT CONTAINING PHYSIOLOGICAL AND MOTION-RELATED INFORMATION

APPLN. TYPE	ENTITY STATUS	ISSUE FEE DUE	PUBLICATION FEE DUE	PREV. PAID ISSUE FEE	TOTAL FEE(S) DUE	DATE DUE
nonprovisional	UNDISCOUNTED	\$960	\$0	\$0	\$960	02/06/2015

EXAMINER	ART UNIT	CLASS-SUBCLASS
FULLER, RODNEY EVAN	2852	600-310000

<p>1. Change of correspondence address or indication of "Fee Address" (37 CFR 1.363).</p> <p><input type="checkbox"/> Change of correspondence address (or Change of Correspondence Address form PTO/SB/122) attached.</p> <p><input type="checkbox"/> "Fee Address" indication (or "Fee Address" Indication form PTO/SB/47; Rev 03-02 or more recent) attached. <b>Use of a Customer Number is required.</b></p>	<p>2. For printing on the patent front page, list</p> <p>(1) The names of up to 3 registered patent attorneys or agents OR, alternatively,</p> <p>(2) The name of a single firm (having as a member a registered attorney or agent) and the names of up to 2 registered patent attorneys or agents. If no name is listed, no name will be printed.</p> <p>1 <u>Myers Bigel Sibley &amp; Sajovec</u></p> <p>2 _____</p> <p>3 _____</p>
---	---

3. ASSIGNEE NAME AND RESIDENCE DATA TO BE PRINTED ON THE PATENT (print or type)

PLEASE NOTE: Unless an assignee is identified below, no assignee data will appear on the patent. If an assignee is identified below, the document has been filed for recordation as set forth in 37 CFR 3.11. Completion of this form is NOT a substitute for filing an assignment.

(A) NAME OF ASSIGNEE: Valencell, Inc.

(B) RESIDENCE: (CITY and STATE OR COUNTRY) Raleigh, NC

Please check the appropriate assignee category or categories (will not be printed on the patent):  Individual  Corporation or other private group entity  Government

<p>4a. The following fee(s) are submitted:</p> <p><input checked="" type="checkbox"/> Issue Fee</p> <p><input type="checkbox"/> Publication Fee (No small entity discount permitted)</p> <p><input type="checkbox"/> Advance Order - # of Copies _____</p>	<p>4b. Payment of Fee(s): (Please first reapply any previously paid issue fee shown above)</p> <p><input type="checkbox"/> A check is enclosed.</p> <p><input type="checkbox"/> Payment by credit card. Form PTO-2038 is attached.</p> <p><input checked="" type="checkbox"/> The Director is hereby authorized to charge the required fee(s), any deficiency, or credits any overpayment, to Deposit Account Number <u>50-0220</u> (enclose an extra copy of this form).</p>
--	---

5. Change in Entity Status (from status indicated above)

Applicant certifying micro entity status. See 37 CFR 1.29

Applicant asserting small entity status. See 37 CFR 1.27

Applicant changing to regular undiscounted fee status.

**NOTE:** Absent a valid certification of Micro Entity Status (see forms PTO/SB/15A and 15B), issue fee payment in the micro entity amount will not be accepted at the risk of application abandonment.

**NOTE:** If the application was previously under micro entity status, checking this box will be taken to be a notification of loss of entitlement to micro entity status.

**NOTE:** Checking this box will be taken to be a notification of loss of entitlement to small or micro entity status, as applicable.

NOTE: This form must be signed in accordance with 37 CFR 1.31 and 1.33. See 37 CFR 1.4 for signature requirements and certifications.

Authorized Signature *Needham J. Boddie II* Date 11/21/2014

Typed or printed name Needham J. Boddie, II Registration No. 40,519

## Electronic Patent Application Fee Transmittal

<b>Application Number:</b>	14184396
<b>Filing Date:</b>	19-Feb-2014
<b>Title of Invention:</b>	METHODS AND APPARATUS FOR GENERATING DATA OUTPUT CONTAINING PHYSIOLOGICAL AND MOTION-RELATED INFORMATION
<b>First Named Inventor/Applicant Name:</b>	Steven Francis LeBoeuf
<b>Filer:</b>	Needham J. Boddie/Candi Riggs
<b>Attorney Docket Number:</b>	9653-7TSCT2

Filed as Large Entity

### Utility under 35 USC 111(a) Filing Fees

Description	Fee Code	Quantity	Amount	Sub-Total in USD(\$)
<b>Basic Filing:</b>				
<b>Pages:</b>				
<b>Claims:</b>				
<b>Miscellaneous-Filing:</b>				
<b>Petition:</b>				
<b>Patent-Appeals-and-Interference:</b>				
<b>Post-Allowance-and-Post-Issuance:</b>				
Utility Appl Issue Fee	1501	1	960	960

**Extension-of-Time:**

Description	Fee Code	Quantity	Amount	Sub-Total in USD(\$)
<b>Miscellaneous:</b>				
<b>Total in USD (\$)</b>				<b>960</b>

## Electronic Acknowledgement Receipt

<b>EFS ID:</b>	20767540
<b>Application Number:</b>	14184396
<b>International Application Number:</b>	
<b>Confirmation Number:</b>	8272
<b>Title of Invention:</b>	METHODS AND APPARATUS FOR GENERATING DATA OUTPUT CONTAINING PHYSIOLOGICAL AND MOTION-RELATED INFORMATION
<b>First Named Inventor/Applicant Name:</b>	Steven Francis LeBoeuf
<b>Customer Number:</b>	20792
<b>Filer:</b>	Needham J. Boddie/Candi Riggs
<b>Filer Authorized By:</b>	Needham J. Boddie
<b>Attorney Docket Number:</b>	9653-7TSCT2
<b>Receipt Date:</b>	21-NOV-2014
<b>Filing Date:</b>	19-FEB-2014
<b>Time Stamp:</b>	14:50:24
<b>Application Type:</b>	Utility under 35 USC 111(a)

### Payment information:

Submitted with Payment	yes
Payment Type	Deposit Account
Payment was successfully received in RAM	\$960
RAM confirmation Number	1136
Deposit Account	500220
Authorized User	

### File Listing:

Document Number	Document Description	File Name	File Size(Bytes)/ Message Digest	Multi Part /.zip	Pages (if appl.)
-----------------	----------------------	-----------	-------------------------------------	------------------	------------------

1	Issue Fee Payment (PTO-85B)	9653-7TSCT2_FeesTransmittal.pdf	151689	no	1
			c9c27ec87fcc16a684cf03d1c2f8d1a82c6501b2		

**Warnings:**

**Information:**

2	Fee Worksheet (SB06)	fee-info.pdf	30789	no	2
			be1bd009bf80936403bf1e7caeba1b2f31a07f0f		

**Warnings:**

**Information:**

<b>Total Files Size (in bytes):</b>			182478		
-------------------------------------	--	--	--------	--	--

**This Acknowledgement Receipt evidences receipt on the noted date by the USPTO of the indicated documents, characterized by the applicant, and including page counts, where applicable. It serves as evidence of receipt similar to a Post Card, as described in MPEP 503.**

**New Applications Under 35 U.S.C. 111**

**If a new application is being filed and the application includes the necessary components for a filing date (see 37 CFR 1.53(b)-(d) and MPEP 506), a Filing Receipt (37 CFR 1.54) will be issued in due course and the date shown on this Acknowledgement Receipt will establish the filing date of the application.**

**National Stage of an International Application under 35 U.S.C. 371**

**If a timely submission to enter the national stage of an international application is compliant with the conditions of 35 U.S.C. 371 and other applicable requirements a Form PCT/DO/EO/903 indicating acceptance of the application as a national stage submission under 35 U.S.C. 371 will be issued in addition to the Filing Receipt, in due course.**

**New International Application Filed with the USPTO as a Receiving Office**

**If a new international application is being filed and the international application includes the necessary components for an international filing date (see PCT Article 11 and MPEP 1810), a Notification of the International Application Number and of the International Filing Date (Form PCT/RO/105) will be issued in due course, subject to prescriptions concerning national security, and the date shown on this Acknowledgement Receipt will establish the international filing date of the application.**



<b>INFORMATION DISCLOSURE STATEMENT BY APPLICANT</b> <i>(use as many sheets as necessary)</i>				<b>Complete if Known</b>			
				Application Number		To Be Assigned	
				Filing Date		Concurrently Herewith	
				First Named Inventor		Steven Francis LeBeouf	
				Art Unit			
				Examiner Name			
Sheet	<b>A1</b>	of	<b>A2</b>	Attorney Docket Number	9653-7TSCT2		

U.S. PATENT DOCUMENTS						
Examiner Initials*	Cite No.	Document Number		Publication Date MM-DD-YYYY	Name of Patentee or Applicant of Cited Document	Pages, Columns, Lines, Where Relevant Passages or Relevant Figures Appear
		Number-Kind Code (if known)				
	1.	US-	2013/0131519	05-2013	LeBoeuf et al.	
	2.	US-	2012/0197093	08-2012	LeBoeuf et al.	
	3.	US-	2011/0105869 A1	05-2011	Wilson et al.	
	4.	US-	2009/0287067 A1	11-2009	Dorogusker et al.	
	5.	US-	2009/0270698 A1	10-2009	Shioi et al.	
	6.	US-	2009/0105556 A1	04-2009	Fricke et al.	
	7.	US-	2009/0054752 A1	02-2009	Jonnalagadda et al.	
	8.	US-	2009/0030350 A1	01-29-2009	Yang et al.	
	9.	US-	2008/0177162 A1	07-2008	Bae et al.	
	10.	US-	2008/0165017 A1	07-2008	Schwartz	
	11.	US-	2008/0096726 A1	04-2008	Riley et al.	
	12.	US-	2008/0076972 A1	03-2008	Dorogusker et al.	
	13.	US-	2006/0009685	01-12-2006	Finarov et al.	
	14.	US-	2005/0228299	10-13-2005	Banet	
	15.	US-	2005/0209516	09-22-2005	Fraden	
	16.	US-	2005/0177034 A1	08-2005	Beaumont	
	17.	US-	8,512,242 B2	08-2013	LeBoeuf et al.	
	18.	US-	8,251,903 B2	08-2012	LeBoeuf et al.	
	19.	US-	8,055,319 B2	11-2011	Oh et al.	
	20.	US-	7,209,775 B2	04-2007	Bae et al.	
	21.	US-	6,859,658 B1	02-2005	Krug	
	22.	US-	6,808,473 B2	10-2004	Hisano et al.	
	23.	US-	6,371,925 B1	04-2002	Imai et al.	
	24.	US-	6,783,501 B2	08-31-2001 2004	Takahashi et al.	
	25.	US-	6,080,110 A	06-2000	Thorgersen	
	26.	US-	6,078,829 A	06-2000	Uchida et al.	

Change(s) applied to document,

/MAH/

FOREIGN PATENT DOCUMENTS							
Examiner Initials*	Cite No.	Foreign Patent Document		Publication Date MM-DD-YYYY	Name of Patentee or Applicant of Cited Document	Pages, Columns, Lines, Where Relevant Passages or Relevant Figures Appear	T
		Country Code, Number, Kind Code (if known)					
	27	WO	2013/038296 A1	03-21-2013	KONINKLIJKE PHILIPS ELECTRONICS N.V.		
	28	JP	2007-185348	07-26-2007	OLYMPUS CORP		
	29	JP	2001-025462	01-30-2001	DENSO CORP		

Examiner Signature	/Rodney Fuller/	Date Considered	05/18/2014
--------------------	-----------------	-----------------	------------

\*EXAMINER: Initial if reference considered, whether or not citation is in conformance with MPEP 609. Draw line through citation if not in conformance and not considered. Include copy of this form with next communication to applicant.

ALL REFERENCES CONSIDERED EXCEPT WHERE LINED THROUGH. /RF/



APPLICATION NO.	ISSUE DATE	PATENT NO.	ATTORNEY DOCKET NO.	CONFIRMATION NO.
14/184,396	12/30/2014	8923941	9653-7TSCT2	8272

20792 7590 12/10/2014  
MYERS BIGEL SIBLEY & SAJOVEC  
PO BOX 37428  
RALEIGH, NC 27627

### ISSUE NOTIFICATION

The projected patent number and issue date are specified above.

#### **Determination of Patent Term Adjustment under 35 U.S.C. 154 (b)** (application filed on or after May 29, 2000)

The Patent Term Adjustment is 0 day(s). Any patent to issue from the above-identified application will include an indication of the adjustment on the front page.

If a Continued Prosecution Application (CPA) was filed in the above-identified application, the filing date that determines Patent Term Adjustment is the filing date of the most recent CPA.

Applicant will be able to obtain more detailed information by accessing the Patent Application Information Retrieval (PAIR) WEB site (<http://pair.uspto.gov>).

Any questions regarding the Patent Term Extension or Adjustment determination should be directed to the Office of Patent Legal Administration at (571)-272-7702. Questions relating to issue and publication fee payments should be directed to the Application Assistance Unit (AAU) of the Office of Data Management (ODM) at (571)-272-4200.

APPLICANT(s) (Please see PAIR WEB site <http://pair.uspto.gov> for additional applicants):

Valencell, Inc., Raleigh, NC, Assignee (with 37 CFR 1.172 Interest);  
Steven Francis LeBoeuf, Raleigh, NC;  
Jesse Berkley Tucker, Knightdale, NC;  
Michael Edward Aumer, Raleigh, NC;

The United States represents the largest, most dynamic marketplace in the world and is an unparalleled location for business investment, innovation, and commercialization of new technologies. The USA offers tremendous resources and advantages for those who invest and manufacture goods here. Through SelectUSA, our nation works to encourage and facilitate business investment. To learn more about why the USA is the best country in the world to develop technology, manufacture products, and grow your business, visit [SelectUSA.gov](http://SelectUSA.gov).

Attorney Docket No. 9653-7TSCT2

PATENT

IN THE UNITED STATES PATENT AND TRADEMARK OFFICE

In re: LeBoeuf et al.

U.S. Patent No.: 8,923,941

Application No.: 14/184,396

Issued: December 30, 2014

Filed: February 19, 2014

Confirmation No: 8272

Title: METHODS AND APPARATUS FOR GENERATING DATA OUTPUT CONTAINING  
PHYSIOLOGICAL AND MOTION-RELATED INFORMATION

March 19, 2015

Commissioner for Patents

Attn: Certificate of Correction Branch

P.O. Box 1450

Alexandria, VA 22313-1450

**REQUEST FOR ENTRY OF CERTIFICATE OF CORRECTION  
UNDER 35 U.S.C. §254 AND 37 C.F.R. §1.322**

Sir:

The Applicants of record for the above-referenced patent hereby request, pursuant to 35 U.S.C. §254 and 37 C.F.R. §1.322, that a Certificate of Correction be issued. This request is made in order to correct the mistakes incurred through the fault of the U.S. Patent and Trademark Office. The mistakes appearing in the patent are set forth with corrections on the Certificate of Correction attached herewith.

No fee is believed due. However, the Commissioner is authorized to charge any deficiency or credit any overpayment to Deposit Account No. 50-0220.

Respectfully submitted,

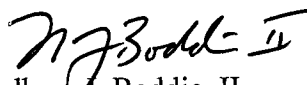

Needham J. Boddie, II

Registration No.: 40,519

Customer No.: 20792

Myers Bigel Sibley & Sajovec, P.A.

P. O. Box 37428, Raleigh, NC 27627

Telephone: (919) 854-1400

Facsimile: (919) 854-1401

**CERTIFICATION OF ELECTRONIC TRANSMISSION**

I hereby certify that this correspondence is being transmitted via the Office electronic filing system in accordance with § 1.6(a)(4) to the U.S. Patent and Trademark Office on March 19, 2015.

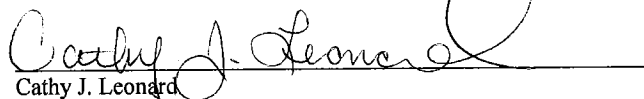
  
Cathy J. Leonard

UNITED STATES PATENT AND TRADEMARK OFFICE  
CERTIFICATE OF CORRECTION

Page 1 of 1

PATENT NO.: 8,923,941  
APPLICATION NO.: 14/184,396  
ISSUE DATE: December 30, 2014  
INVENTOR(S): LeBoeuf et al.

It is certified that an error appears or errors appear in the above-identified patent  
and that said Letters Patent is hereby corrected as shown below:

In the Claims:

Column 30, Claim 2, Line 59: Please correct "breathing rate or volume,"  
to read -- breathing volume, --

MAILING ADDRESS OF SENDER:  
Myers, Bigel, Sibley & Sajovec  
P.O. Box 37428  
Raleigh, NC 27627

## Electronic Acknowledgement Receipt

<b>EFS ID:</b>	21815799
<b>Application Number:</b>	14184396
<b>International Application Number:</b>	
<b>Confirmation Number:</b>	8272
<b>Title of Invention:</b>	METHODS AND APPARATUS FOR GENERATING DATA OUTPUT CONTAINING PHYSIOLOGICAL AND MOTION-RELATED INFORMATION
<b>First Named Inventor/Applicant Name:</b>	Steven Francis LeBoeuf
<b>Customer Number:</b>	20792
<b>Filer:</b>	Needham J. Boddie/Cathy Leonard
<b>Filer Authorized By:</b>	Needham J. Boddie
<b>Attorney Docket Number:</b>	9653-7TSCT2
<b>Receipt Date:</b>	19-MAR-2015
<b>Filing Date:</b>	19-FEB-2014
<b>Time Stamp:</b>	09:59:31
<b>Application Type:</b>	Utility under 35 USC 111(a)

### Payment information:

Submitted with Payment	no
------------------------	----

### File Listing:

Document Number	Document Description	File Name	File Size(Bytes)/ Message Digest	Multi Part /.zip	Pages (if appl.)
1	Request for Certificate of Correction	9653-7TSCT2_Request_for_CO C.pdf	145913 <small>15bb187841ab6d138ca61ef4e40ff6db06675a41</small>	no	2

### Warnings:

### Information:

**This Acknowledgement Receipt evidences receipt on the noted date by the USPTO of the indicated documents, characterized by the applicant, and including page counts, where applicable. It serves as evidence of receipt similar to a Post Card, as described in MPEP 503.**

**New Applications Under 35 U.S.C. 111**

**If a new application is being filed and the application includes the necessary components for a filing date (see 37 CFR 1.53(b)-(d) and MPEP 506), a Filing Receipt (37 CFR 1.54) will be issued in due course and the date shown on this Acknowledgement Receipt will establish the filing date of the application.**

**National Stage of an International Application under 35 U.S.C. 371**

**If a timely submission to enter the national stage of an international application is compliant with the conditions of 35 U.S.C. 371 and other applicable requirements a Form PCT/DO/EO/903 indicating acceptance of the application as a national stage submission under 35 U.S.C. 371 will be issued in addition to the Filing Receipt, in due course.**

**New International Application Filed with the USPTO as a Receiving Office**

**If a new international application is being filed and the international application includes the necessary components for an international filing date (see PCT Article 11 and MPEP 1810), a Notification of the International Application Number and of the International Filing Date (Form PCT/RO/105) will be issued in due course, subject to prescriptions concerning national security, and the date shown on this Acknowledgement Receipt will establish the international filing date of the application.**

UNITED STATES PATENT AND TRADEMARK OFFICE  
**CERTIFICATE OF CORRECTION**

PATENT NO. : 8,923,941 B2  
APPLICATION NO. : 14/184396  
DATED : December 30, 2014  
INVENTOR(S) : LeBoeuf et al.

Page 1 of 1

It is certified that error appears in the above-identified patent and that said Letters Patent is hereby corrected as shown below:

In the Claims:

Column 30, Claim 2, Line 59: Please correct “breathing rate or volume,”  
to read -- breathing volume, --

Signed and Sealed this  
Twenty-third Day of June, 2015



Michelle K. Lee  
*Director of the United States Patent and Trademark Office*