

UNITED STATES PATENT AND TRADEMARK OFFICE

BEFORE THE PATENT TRIAL AND APPEAL BOARD

APPLE INC.
Petitioner,

v.

VALENCELL, INC.
Patent Owner.

IPR2017-00317
Patent 8,989,830 B2

Before BRIAN J. McNAMARA, JAMES B. ARPIN, and
SHEILA F. McSHANE, *Administrative Patent Judges*.

McSHANE, *Administrative Patent Judge*.

DECISION
Instituting *Inter Partes* Review
37 C.F.R. § 42.108

I. INTRODUCTION

A. Background

Apple Inc. (“Petitioner”) filed a Petition requesting *inter partes* review of claims 1–6, 8–16, and 18–20 (“the challenged claims”) of U.S. Patent No. 8,989,830 B2 (Ex. 1001, “the ’830 patent”) pursuant to 35 U.S.C. §§ 311–319. Paper 2 (“Pet.”). Valencell, Inc. (“Patent Owner”) filed a Preliminary Response to the Petition. Paper 6 (“Prelim. Resp.”).

We have authority under 35 U.S.C. § 314(a), which provides that an *inter partes* review may not be instituted “unless . . . the information presented in the petition . . . shows that there is a reasonable likelihood that the Petitioner would prevail with respect to at least 1 of the claims challenged in the petition.”

We determine that Petitioner has demonstrated that there is a reasonable likelihood that it would prevail with respect to at least one of the challenged claims. For the reasons set forth below, we institute an *inter partes* review of claims 1–6, 8–16, and 18–20.

B. Related Proceedings

The parties indicate that the ’830 patent is at issue in *Valencell, Inc. v. Apple Inc.*, Case No. 5:16-cv-00001 (E.D.N.C), and *Valencell, Inc. v. Fitbit, Inc.*, Case No. 5:16-cv-00002 (E.D.N.C). Pet. 3; Paper 5, 1. Patent Owner indicates the ’830 patent is also at issue in *Valencell, Inc. v. Bragi Store, LLC*, Case No. 5:16-cv-00895 (E.D.N.C.). Paper 5, 1.

In addition to this Petition, Petitioner indicates that it filed another *inter partes* review petition challenging claims of the ’830 patent (IPR2017-00316), and also filed another *inter partes* review petition (IPR2017-00318)

IPR2017-00317

Patent 8,989,830 B2

challenging claims of U.S. Patent No. 8,886,269 B2, which is the parent of the '830 patent. Pet. 3.

C. The '830 Patent

The '830 patent is entitled “Wearable Light-Guiding Devices For Physiological Monitoring” and issued on March 24, 2015 from an application filed on September 12, 2014. Ex. 1001, [22], [45], [54]. The '830 patent claims priority to U.S. Patent Application No. 14/184,364, filed on February 19, 2014 (now U.S. Patent No. 8,886,269 B2), and U.S. Patent Application No. 12/691,388, filed on January 21, 2010 (now U.S. Patent 8,700,111). *Id.* at [63].

The '830 patent is directed to monitoring devices configured to be attached to the body of a subject. Ex. 1001, Abstract. The monitoring devices may include physiological sensors to measure, for example, heart rate, pulse rate, breathing rate, and a variety of other physical parameters. *Id.*, 4:33–67. The sensors, for example, may be photoplethysmography (“PPG”) sensors for measuring blood flow properties, such as blood oxygen level. *Id.* at 3:67–4:5. The '830 patent discloses various embodiments of the monitoring devices, such as that depicted in Figures 22A and 22B, reproduced below.

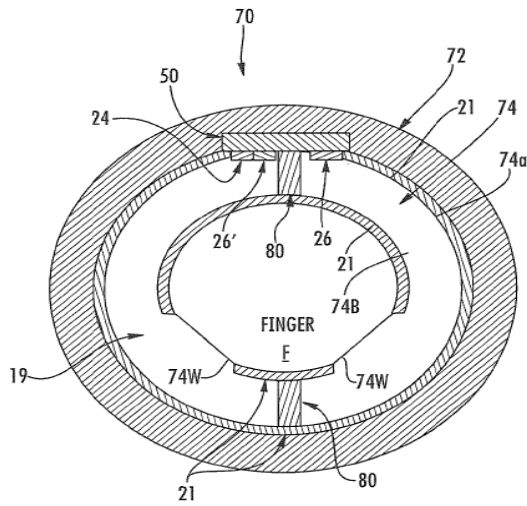

FIG. 22B

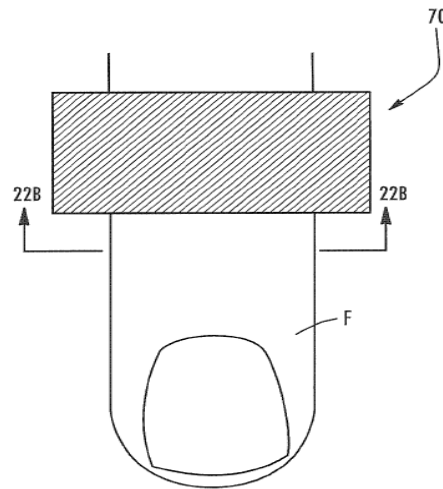

FIG. 22A

Figure 22A is a top plan of an embodiment of monitoring device 70 configured to be attached to the finger of a subject, and Figure 22B is a cross-sectional view of the monitoring device. Ex. 1001, 8:16–20. The monitoring device that fits over the finger has outer body portion 72 that may include a flex circuit, and base 50 secured to inner body portion 74 and outer body portion 72. *Id.* at 28:1–10. Base 50 supports optical emitter 24, optical detector 26, and optical noise detector 26'. *Id.* at 28:19–21. Layer of cladding material 21 is applied to (or near) outer surface 74a of inner body portion 74, as well as inner surface 74b, to serve as a light guide to deliver light from optical emitter 24 to the finger and to collect light from the finger and deliver it to optical detectors 26, 26'. *Id.* at 28:30–38. “[W]indows 74w are formed in the cladding material 21 and serve as light-guiding interfaces to the finger.” *Id.* at 28:44–46. The device also may be embodied in “a patch, such as a bandage that sticks on a person’s body.” *Id.* at 11:53–58.

The '830 patent discloses an embodiment of the invention illustrated in Figure 3, reproduced below.

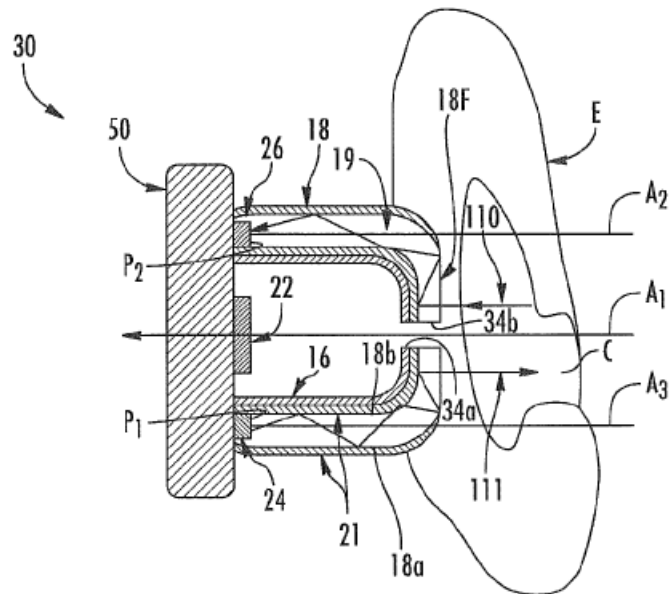

FIG. 3

Figure 3 depicts an embodiment of monitoring device showing a side section view of a headset with a light-guiding earbud. Ex. 1001, 7:7–9.

Earbud 30 includes optical detector 26 and optical emitter 24. Ex. 1001, 14:52–53. Cladding material 21 is used to confine light within light guiding region 19. *Id.* at 14:60–63.

Claim 1, reproduced below, is illustrative of the challenged claims of the '830 patent.

1. A monitoring device configured to be attached to the body of a subject, comprising:
 - an outer layer and an inner layer secured together, the inner layer comprising light transmissive material, and having inner and outer surfaces;
 - a base secured to at least one of the outer and inner layers and comprising at least one optical emitter and at least one optical detector;
 - a layer of cladding material near the outer surface of the inner layer; and
 - at least one window formed in the layer of cladding material that serves as a light-guiding interface to the body of the

Explore Litigation Insights

Docket Alarm provides insights to develop a more informed litigation strategy and the peace of mind of knowing you're on top of things.

Real-Time Litigation Alerts



Keep your litigation team up-to-date with **real-time alerts** and advanced team management tools built for the enterprise, all while greatly reducing PACER spend.

Our comprehensive service means we can handle Federal, State, and Administrative courts across the country.

Advanced Docket Research



With over 230 million records, Docket Alarm's cloud-native docket research platform finds what other services can't. Coverage includes Federal, State, plus PTAB, TTAB, ITC and NLRB decisions, all in one place.

Identify arguments that have been successful in the past with full text, pinpoint searching. Link to case law cited within any court document via Fastcase.

Analytics At Your Fingertips



Learn what happened the last time a particular judge, opposing counsel or company faced cases similar to yours.

Advanced out-of-the-box PTAB and TTAB analytics are always at your fingertips.

API

Docket Alarm offers a powerful API (application programming interface) to developers that want to integrate case filings into their apps.

LAW FIRMS

Build custom dashboards for your attorneys and clients with live data direct from the court.

Automate many repetitive legal tasks like conflict checks, document management, and marketing.

FINANCIAL INSTITUTIONS

Litigation and bankruptcy checks for companies and debtors.

E-DISCOVERY AND LEGAL VENDORS

Sync your system to PACER to automate legal marketing.