

Under the Paperwork Reduction Act of 1995 no persons are required to respond to a collection of information unless it displays a valid OMB control number

<b>UTILITY                  PATENT APPLICATION                  TRANSMITTAL</b>  <i>(Only for new nonprovisional applications under 37 CFR 1.53(b))</i>	Attorney Docket No.	9653-7TSC5
	First Named Inventor	Steven Francis LeBoeuf
	Title	Wearable Light-Guiding Devices...
	Express Mail Label No.	

<p style="text-align: center;"><b>APPLICATION ELEMENTS</b>                  See MPEP chapter 600 concerning utility patent application contents.</p> <p>1. <input type="checkbox"/> Fee Transmittal Form (PTO/SB/17 or equivalent)</p> <p>2. <input type="checkbox"/> Applicant asserts small entity status. See 37 CFR 1.27</p> <p>3. <input type="checkbox"/> Applicant certifies micro entity status. See 37 CFR 1.29. Applicant must attach form PTO/SB/15A or B or equivalent.</p> <p>4. <input checked="" type="checkbox"/> Specification [Total Pages <u>51</u>]                  Both the claims and abstract must start on a new page. (See MPEP § 608.01(a) for information on the preferred arrangement)</p> <p>5. <input checked="" type="checkbox"/> Drawing(s) (35 U.S.C. 113) [Total Sheets <u>21</u>]</p> <p>6. <input checked="" type="checkbox"/> Inventor's Oath or Declaration [Total Pages <u>2</u>]                  (including substitute statements under 37 CFR 1.64 and assignments serving as an oath or declaration under 37 CFR 1.63(e))</p> <p>a. <input checked="" type="checkbox"/> Newly executed (original or copy)</p> <p>b. <input type="checkbox"/> A copy from a prior application (37 CFR 1.63(d))</p> <p>7. <input checked="" type="checkbox"/> Application Data Sheet * See note below. See 37 CFR 1.76 (PTO/AIA/14 or equivalent)</p> <p>8. <input type="checkbox"/> CD-ROM or CD-R                  In duplicate, large table, or Computer Program (Appendix)</p> <p><input type="checkbox"/> Landscape Table on CD</p> <p>9. Nucleotide and/or Amino Acid Sequence Submission (if applicable, items a. - c. are required)</p> <p>a. <input type="checkbox"/> Computer Readable Form (CRF)</p> <p>b. <input type="checkbox"/> Specification Sequence Listing on:</p> <p>i. <input type="checkbox"/> CD-ROM or CD-R (2 copies); or</p> <p>ii. <input type="checkbox"/> Paper</p> <p>c. <input type="checkbox"/> Statements verifying identity of above copies</p>	<p style="text-align: center;"><b>ADDRESS TO:</b></p> <p style="text-align: center;">Commissioner for Patents                  P.O. Box 1450                  Alexandria, VA 22313-1450</p> <p style="text-align: center;"><b>ACCOMPANYING APPLICATION PAPERS</b></p> <p>10. <input type="checkbox"/> Assignment Papers (cover sheet &amp; document(s))                  Name of Assignee _____</p> <p>11. <input type="checkbox"/> 37 CFR 3.73(c) Statement (when there is an assignee) <input checked="" type="checkbox"/> Power of Attorney</p> <p>12. <input type="checkbox"/> English Translation Document (if applicable)</p> <p>13. <input checked="" type="checkbox"/> Information Disclosure Statement (PTO/SB/08 or PTO-1449)  <input type="checkbox"/> Copies of citations attached</p> <p>14. <input type="checkbox"/> Preliminary Amendment</p> <p>15. <input type="checkbox"/> Return Receipt Postcard (MPEP § 503) (Should be specifically itemized)</p> <p>16. <input type="checkbox"/> Certified Copy of Priority Document(s) (if foreign priority is claimed)</p> <p>17. <input type="checkbox"/> Nonpublication Request Under 35 U.S.C. 122(b)(2)(B)(i). Applicant must attach form PTO/SB/35 or equivalent.</p> <p>18. <input type="checkbox"/> Other: _____</p>
---	--

\*Note: (1) Benefit claims under 37 CFR 1.78 and foreign priority claims under 1.55 must be included in an Application Data Sheet (ADS).  
 (2) For applications filed under 35 U.S.C. 111, the application must contain an ADS specifying the applicant if the applicant is an assignee, person to whom the inventor is under an obligation to assign, or person who otherwise shows sufficient proprietary interest in the matter. See 37 CFR 1.46(b).

**19. CORRESPONDENCE ADDRESS**

The address associated with Customer Number: 20792 OR  Correspondence address below

Name			
Address			
City	State	Zip Code	
Country	Telephone	Email	

Signature	<i>Needham J. Boddie II</i>	Date	September 12, 2014
Name (Print/Type)	Needham J. Boddie, II	Registration No. (Attorney/Agent)	40,519

This collection of information is required by 37 CFR 1.53(b). The information is required to obtain or retain a benefit by the public which is to file (and by the USPTO to process) an application. Confidentiality is governed by 35 U.S.C. 122 and 37 CFR 1.11 and 1.14. This collection is estimated to take 12 minutes to complete, including gathering, preparing, and submitting the completed application form to the USPTO. Time will vary depending upon the individual case. Any comments on the amount of time you require to complete this form and/or suggestions for reducing this burden, should be sent to the Chief Information Officer, U.S. Patent and Trademark Office, U.S. Department of Commerce, P.O. Box 1450, Alexandria, VA 22313-1450. DO NOT SEND FEES OR COMPLETED FORMS TO THIS ADDRESS. SEND TO: Commissioner for Patents, P.O. Box 1450, Alexandria, VA 22313-1450.

If you need assistance in completing the form, call 1-800-PTO-9199 and select option 2.

## WEARABLE LIGHT-GUIDING DEVICES FOR PHYSIOLOGICAL MONITORING

### RELATED APPLICATIONS

This application is a continuation application of pending U.S. Patent Application Serial No. 14/184,364, filed February 19, 2014, which is a continuation application of U.S. Patent Application Serial No. 12/691,388, filed January 21, 5 2010, now U.S. Patent No. 8,700,111, and which claims the benefit of and priority to U.S. Provisional Patent Application No. 61/208,567 filed February 25, 2009, U.S. Provisional Patent Application No. 61/208,574 filed February 25, 2009, U.S. Provisional Patent Application No. 61/212,444 filed April 13, 2009, and U.S. Provisional Patent Application No. 61/274,191 filed August 14, 2009, the 10 disclosures of which are incorporated herein by reference as if set forth in their entireties.

### FIELD OF THE INVENTION

The present invention relates generally to headsets and, more 15 particularly, to headset earbuds.

### BACKGROUND OF THE INVENTION

There is growing market demand for personal health and environmental monitors, for example, for gauging overall health and metabolism 20 during exercise, athletic training, dieting, daily life activities, sickness, and physical therapy. However, traditional health monitors and environmental monitors may be bulky, rigid, and uncomfortable – generally not suitable for use during daily physical activity. There is also growing interest in generating and comparing health and environmental exposure statistics of the general public 25 and particular demographic groups. For example, collective statistics may enable the healthcare industry and medical community to direct healthcare resources to where they are most highly valued. However, methods of collecting these

statistics may be expensive and laborious, often utilizing human-based recording/analysis steps at multiple sites.

As such, improved ways of collecting, storing and analyzing physiological information are needed. In addition, improved ways of seamlessly extracting physiological information from a person during everyday life activities, especially during high activity levels, may be important for enhancing fitness training and healthcare quality, promoting and facilitating prevention, and reducing healthcare costs.

## SUMMARY

It should be appreciated that this Summary is provided to introduce a selection of concepts in a simplified form, the concepts being further described below in the Detailed Description. This Summary is not intended to identify key features or essential features of this disclosure, nor is it intended to limit the scope of the invention.

According to some embodiments of the present invention, a headset configured to be attached to the ear of a person includes a base, an earbud housing extending outwardly from the base that is configured to be positioned within an ear of a subject, and a cover surrounding the earbud housing. The base includes a speaker, an optical emitter, and an optical detector. The cover includes light transmissive material that is in optical communication with the optical emitter and the optical detector and serves as a light guide to deliver light from the optical emitter into the ear canal of the subject wearing the headset at one or more predetermined locations and to collect light external to the earbud housing and deliver the collected light to the optical detector. The optical emitter, via the light-guiding cover, directs optical energy towards a particular region of ear and the optical detector detects secondary optical energy emanating from the ear region. In some embodiments, the optical detector may include an optical filter configured to pass secondary optical energy at selective wavelengths. In some embodiments, the light transmissive material of the cover may be configured, for example via the use of cladding and/or light reflective material, such that the cover serves as a light guide that is coupled in parallel to the optical emitter and detector. In some embodiments, the light transmissive material of the cover may be configured, for example via the use of

cladding and/or light reflective material, such that the cover serves as a light guide that is coupled perpendicular to the optical emitter and detector.

In some embodiments, the headset may include various electronic components secured to the base. For example, the headset may include one or  
5 more environmental sensors configured to detect and/or measure environmental conditions in a vicinity of the headset. The headset may include a signal processor configured to receive and process signals produced by the optical detector. For example, in some embodiments, a signal processor may be configured to extract secondary optical energy and remove optical noise or  
10 environmental noise. The headset may include a signal processor configured to receive and process signals produced by the one or more environmental sensors. In addition, the headset may include a transmitter configured to transmit signals processed by the signal processor to a remote device in real time. Headsets according to embodiments of the present invention may utilize, for  
15 example, Bluetooth®, Wi-Fi, ZigBee, or other wireless transmitters.

In some embodiments, a housing is secured to and overlies the base so as to enclose and protect the speaker, optical emitter and optical detector, as well as other electronic components secured to the base (e.g., sensors, processor, transmitter etc.).

20 The earbud housing is in acoustical communication with the speaker and has at least one aperture through which sound from the speaker can pass. The light-guiding cover surrounding the earbud housing also includes at least one aperture through which sound from the speaker can pass. The cover may be formed from a soft, resilient material, such as silicone which deforms  
25 when inserted within an ear canal of a subject. In some embodiments, the cover includes an alignment member that facilitates alignment of the earbud housing within an ear canal of a subject.

Light directed into the ear of a subject from a light emitter and the subsequent collection of light at a light detector, according to embodiments of  
30 the present invention, may be utilized for detecting and/or measuring, among other things, body temperature, skin temperature, blood gas levels, muscle tension, heart rate, blood flow, cardiopulmonary functions, etc.

In some embodiments of the present invention, the light-guiding cover may include a lens that is in optical communication with the optical emitter



and/or optical detector. The lens may be configured to focus light emitted by the optical emitter and/or to focus collected light toward the optical detector. In some embodiments, multiple lenses may be incorporated into a light-guiding cover.

5 In some embodiments, the light-guiding cover may include a light diffusion region in optical communication with the light transmissive material that diffuses light emitted by the optical detector.

10 In some embodiments, the light-guiding cover may include a luminescence-generating region, such as a phosphor-containing region, that is in optical communication with the light transmissive material. The luminescence-generating region may be embedded within the light-guiding cover and/or on a surface of the light-guiding cover. The luminescence-generating region is configured to receive light emitted by the optical emitter and convert at least a portion of the received light to light having a different wavelength from that of the received light.

15 In some embodiments, the light-guiding cover includes one or more grooves formed therein. Each groove is configured to direct external light to the optical detector.

20 In some embodiments, the light transmissive material of the light-guiding cover is configured to direct light from the optical emitter to a plurality of locations at an outer surface of the cover for delivery into an ear canal of a subject.

In some embodiments, the light transmissive material of the light-guiding cover is a translucent material or includes translucent material in selected locations.

25 In some embodiments, a light reflective material is on at least a portion of one or both of the inner and outer surfaces of the light-guiding cover.

30 According to some embodiments of the present invention, a light-guiding earbud for a headset includes light transmissive material that is in optical communication with an optical emitter and optical detector associated with the headset. The light transmissive material is configured to deliver light from the optical emitter into the ear canal of a subject at one or more predetermined locations and to collect light external to the earbud housing and deliver the collected light to the optical detector. In some embodiments, the light emitter and light detector may be integral with the earbud. For example, in some

embodiments, a flexible optical emitter is incorporated within the earbud and is in optical communication with the light transmissive material.

In some embodiments, an earbud includes at least one lens in optical communication with the light transmissive material. Each lens may be  
5 configured to focus light from the optical emitter onto one or more predetermined locations in the ear of a subject and/or to focus collected external light onto the optical detector.

In some embodiments of the present invention, an earbud may include luminescent material. Luminescent light is generated from optical  
10 excitation of the luminescent material by an optical emitter.

In some embodiments of the present invention, an earbud may integrate a sensor module containing a plurality of sensor elements for measuring physiological information and at least one noise source for measuring noise information. A "noise source", as used herein, refers to a sensor, such as  
15 an optical sensor, inertial sensor, electrically conductive sensor, capacitive sensor, inductive sensor, etc., and derives its name from the fact that it is a source of input to a filter, such as an adaptive filter described below.

The physiological sensors of the sensor module may generate a signal that includes physiological information plus noise information. The noise  
20 may be removed by combining the physiological information and noise information from the sensor module with noise information from the noise source of the sensor module via an electronic filtering method, such as a signal processing technique. Specific examples of such signal processing techniques include FIR (Finite Impulse Response), IIR (Infinite Impulse Response),  
25 informatics, machine learning, and adaptive filter methods. The output of the adaptive filter may be a physiological signal that is wholly or partially free of noise. In some embodiments, motion-related noise from a subject activity such as running may be removed from the physiological plus noise signal generated by a photoplethysmography (PPG) sensor for measuring blood constituent levels  
30 or blood flow properties, such as blood oxygen level,  $VO_2$ , or heart rate.

In some embodiments of the present invention, the noise source input of an adaptive filter may include a "blocked channel" of optical energy, an inertial sensor, or environmental energy. In some embodiments, the environmental energy may be unwanted ambient optical noise.

In some embodiments of the present invention, a processor/multiplexor processes physiological signals and noise signals into a data string. This data string may contain information relating to physiological information and motion-related information. The processing method may include  
5 signal processing techniques such as pre-adaptive signal conditioning, adaptive filtering, and parameter extraction.

In some embodiments, an earbud includes one or more sensor modules that includes one or more sensors for sensing physiological information and environmental information, such as noise, for example. As such, the earbud  
10 may function as a physiological monitor as well as an environmental monitor. In some embodiments, the earbud may include a microprocessor that is in electrical communication with the sensor module(s). For example, a microprocessor incorporated into an earbud may be configured to execute an adaptive filter algorithm to remove noise from at least one signal generated by a  
15 sensor module in the earbud. A microprocessor may also be configured to process information from the one or more sensors to generate a digital output string, wherein the digital output string includes a plurality of physiological and motion-related information.

Physiological sensors that may be incorporated into headsets  
20 and/or earbuds, according to some embodiments of the present invention, may be configured to detect and/or measure one or more of the following types of physiological information: heart rate, pulse rate, breathing rate, blood flow,  $VO_2$ ,  $VO_2$ max, heartbeat signatures, cardio-pulmonary health, organ health, metabolism, electrolyte type and/or concentration, physical activity, caloric  
25 intake, caloric metabolism, blood metabolite levels or ratios, blood pH level, physical and/or psychological stress levels and/or stress level indicators, drug dosage and/or dosimetry, physiological drug reactions, drug chemistry, biochemistry, position and/or balance, body strain, neurological functioning, brain activity, brain waves, blood pressure, cranial pressure, hydration level,  
30 auscultatory information, auscultatory signals associated with pregnancy, physiological response to infection, skin and/or core body temperature, eye muscle movement, blood volume, inhaled and/or exhaled breath volume, physical exertion, exhaled breath physical and/or chemical composition, the presence and/or identity and/or concentration of viruses and/or bacteria, foreign

matter in the body, internal toxins, heavy metals in the body, anxiety, fertility, ovulation, sex hormones, psychological mood, sleep patterns, hunger and/or thirst, hormone type and/or concentration, cholesterol, lipids, blood panel, bone density, organ and/or body weight, reflex response, sexual arousal, mental  
5 and/or physical alertness, sleepiness, auscultatory information, response to external stimuli, swallowing volume, swallowing rate, sickness, voice characteristics, voice tone, voice pitch, voice volume, vital signs, head tilt, allergic reactions, inflammation response, auto-immune response, mutagenic response, DNA, proteins, protein levels in the blood, water content of the blood,  
10 pheromones, internal body sounds, digestive system functioning, cellular regeneration response, healing response, stem cell regeneration response, etc.

Environmental sensors that may be incorporated into headsets and/or earbuds, according to some embodiments of the present invention, may be configured to detect and/or measure one or more of the following types of  
15 environmental information: climate, humidity, temperature, pressure, barometric pressure, soot density, airborne particle density, airborne particle size, airborne particle shape, airborne particle identity, volatile organic chemicals (VOCs), hydrocarbons, polycyclic aromatic hydrocarbons (PAHs), carcinogens, toxins, electromagnetic energy, optical radiation, X-rays, gamma rays, microwave  
20 radiation, terahertz radiation, ultraviolet radiation, infrared radiation, radio waves, atomic energy alpha particles, atomic energy beta-particles, gravity, light intensity, light frequency, light flicker, light phase, ozone, carbon monoxide, carbon dioxide, nitrous oxide, sulfides, airborne pollution, foreign material in the air, viruses, bacteria, signatures from chemical weapons, wind, air turbulence,  
25 sound and/or acoustical energy, ultrasonic energy, noise pollution, human voices, animal sounds, diseases expelled from others, exhaled breath and/or breath constituents of others, toxins from others, pheromones from others, industrial and/or transportation sounds, allergens, animal hair, pollen, exhaust from engines, vapors and/or fumes, fuel, signatures for mineral deposits and/or  
30 oil deposits, snow, rain, thermal energy, hot surfaces, hot gases, solar energy, hail, ice, vibrations, traffic, the number of people in a vicinity of the person, coughing and/or sneezing sounds from people in the vicinity of the person, loudness and/or pitch from those speaking in the vicinity of the person.

According to some embodiments of the present invention, earbuds

for headsets may include a chipset having at least one sensor element, noise source element, signal processor, input/output line, digital control, and power regulator.

5 Light-guiding earbuds according to the various embodiments of the present invention may be utilized with mono headsets (i.e., headsets having one earbud) as well as stereo headsets (i.e., headsets having two earbuds). Additionally, the light-guiding region of earbuds, according to embodiments of the present invention, may be integrated not only into an earbud cover and earbud housing, but also into each or all components of an earbud. Moreover,  
10 light-guiding earbuds according to the various embodiments of the present invention may be utilized with hearing aids, body jewelry, or any other attachment that can be placed near the head region, such as eye glasses or shades, a headband, a cap, helmet, visor, or the like.

According to some embodiments of the present invention, a  
15 monitoring device includes a circular band capable of encircling a finger of a subject, and a base having an optical emitter and an optical detector attached to the circular band. The circular band includes light transmissive material in optical communication with the optical emitter and optical detector that is configured to deliver light from the optical emitter to one or more portions of the finger of the  
20 subject and to collect light from one or more portions of the finger of the subject and deliver the collected light to the optical detector. In some embodiments, the circular band includes first and second concentric body portions.

In some embodiments, the circular band includes a lens region in optical communication with the optical emitter that focuses light emitted by the  
25 optical emitter and/or that collects light reflected from a finger. In some embodiments the circular band includes a phosphor-containing region in optical communication with the light transmissive material, wherein the phosphor-containing region receives light emitted by the optical emitter and converts at least a portion of the received light to light having a different wavelength from the  
30 received light.

In some embodiments, the light transmissive material of the circular band has an outer surface and an inner surface, and a cladding material, such as light reflective material, is on (or near) at least a portion of one or both of the inner and outer surfaces.

In some embodiments, the base includes one or more of the following: a signal processor configured to receive and process signals produced by the optical detector, a transmitter configured to transmit signals processed by the signal processor to a remote device.

5           According to some embodiments of the present invention, a monitoring device configured to be attached to the body of a subject includes a base having an optical emitter and an optical detector, and light transmissive material attached to the base. The light transmissive material is in optical communication with the optical emitter and optical detector and is configured to  
10 deliver light from the optical emitter to one or more portions of the body of the subject and to collect light from one or more portions of the body of the subject and deliver the collected light to the optical detector. The light transmissive material may include adhesive material in one or more locations that is configured to adhesively secure the device to the body of the subject.

15           In some embodiments, an outer body portion is attached to the base and to the light transmissive material. The outer body portion may include adhesive material in one or more locations that is configured to adhesively secure the device to the body of the subject.

          In some embodiments, the light transmissive material includes a  
20 lens region that is in optical communication with the optical emitter and that focuses light emitted by the optical emitter and/or that collects light reflected from a finger. In some embodiments, the light transmissive material includes a phosphor-containing region that receives light emitted by the optical emitter and converts at least a portion of the received light to light having a different  
25 wavelength from the received light. In some embodiments, the light transmissive material has an outer surface and an inner surface, and a light reflective material is disposed on or near at least a portion of one or both of the inner and outer surfaces.

          In some embodiments, the base includes one or more of the  
30 following: a signal processor configured to receive and process signals produced by the optical detector, a transmitter configured to transmit signals processed by the signal processor to a remote device.

          It is noted that aspects of the invention described with respect to one embodiment may be incorporated in a different embodiment although not

specifically described relative thereto. That is, all embodiments and/or features of any embodiment can be combined in any way and/or combination. Applicant reserves the right to change any originally filed claim or file any new claim accordingly, including the right to be able to amend any originally filed claim to  
5 depend from and/or incorporate any feature of any other claim although not originally claimed in that manner. These and other objects and/or aspects of the present invention are explained in detail below.

### BRIEF DESCRIPTION OF THE DRAWINGS

10 The accompanying drawings, which form a part of the specification, illustrate various embodiments of the present invention. The drawings and description together serve to fully explain embodiments of the present invention.

Fig. 1 is an exploded perspective view of a headset with a light-guiding earbud, according to some embodiments of the present invention.

15 Fig. 2 is a perspective view of a stereo headset incorporating light-guiding earbuds, according to some embodiments of the present invention.

Fig. 3 is a side section view of a light-guiding earbud for a headset, according to some embodiments of the present invention.

20 Figs. 4A-4D are side section views of light-guiding earbuds for a headset, according to some embodiments of the present invention.

Fig. 5 is a side section view of a light-guiding earbud for a headset, according to some embodiments of the present invention.

Fig. 6 is a side section view of a light-guiding earbud for a headset, according to some embodiments of the present invention.

25 Fig. 7A is a side section view of a light-guiding earbud for a headset, according to some embodiments of the present invention.

Fig. 7B is a perspective view of a flexible optical emitter utilized in the earbud of Fig. 7A, according to some embodiments of the present invention.

30 Fig. 8A is a side section view of a light-guiding earbud for a headset, according to some embodiments of the present invention.

Fig. 8B is a cross-sectional view of the earbud of Fig. 8A taken along lines 8B-8B.

Fig. 8C is a side section view of a light-guiding earbud for a headset, according to some embodiments of the present invention.

Fig. 8D is a side section view of a light-guiding earbud for a headset, according to some embodiments of the present invention.

Fig. 9A is a side section view of a light-guiding earbud for a headset, according to some embodiments of the present invention.

5 Fig. 9B is a cross-sectional view of the earbud of Fig. 9A taken along lines 9B-9B.

Fig. 9C illustrates luminescent particles within the earbud cover of Figs. 9A-9B, according to some embodiments of the present invention.

10 Fig. 9D is a side section view of a light-guiding earbud for a headset, according to some embodiments of the present invention.

Fig. 9E is a cross-sectional view of the earbud of Fig. 9D taken along lines 9E-9E.

Fig. 10 illustrates various anatomy of a human ear.

15 Fig. 11A is a side section view of a light-guiding earbud for a headset, according to some embodiments of the present invention.

Fig. 11B is a cross-sectional view of the earbud of Fig. 11A taken along lines 11B-11B.

20 Figs. 12A-12B illustrate respective opposite sides of a sensor module that may be located near the periphery of an earbud, according to some embodiments of the present invention.

Fig. 13 illustrates an adaptive filter and noise source for removing noise from a noisy physiological signal, according to some embodiments of the present invention.

25 Figs. 14A-14D are respective graphs of time-dependent data collected from a light-guiding earbud worn by a person, according to some embodiments of the present invention.

Fig. 15 is a graph of processed physiological signal data from a headset having one or more light-guiding earbuds, according to some embodiments of the present invention.

30 Fig. 16 is a flow chart of operations for extracting physiological information from headset sensor signals, according to some embodiments of the present invention.

Fig. 17 is a block diagram that illustrates sensor signals being processed into a digital data string including activity data and physiological data,



according to some embodiments of the present invention.

Fig. 18 illustrates a digital data string, according to some embodiments of the present invention.

5 Fig. 19 illustrates the optical interaction between the sensor module of Figs. 12A-12B and the skin of a subject.

Fig. 20 illustrates a chipset for use in a headset, according to some embodiments of the present invention.

Fig. 21 illustrates a chipset for use in a stereo headset, according to some embodiments of the present invention.

10 Fig. 22A is a top plan view of a monitoring device configured to be attached to finger of a subject, according to some embodiments of the present invention.

Fig. 22B is a cross-sectional view of the monitoring device of Fig. 22A taken along lines 22B-22B.

15 Fig. 23 is a side view of a monitoring device configured to be attached to the body of a subject, according to some embodiments of the present invention.

#### DETAILED DESCRIPTION

20 The present invention will now be described more fully hereinafter with reference to the accompanying figures, in which embodiments of the invention are shown. This invention may, however, be embodied in many different forms and should not be construed as limited to the embodiments set forth herein. Like numbers refer to like elements throughout. In the figures, 25 certain layers, components or features may be exaggerated for clarity, and broken lines illustrate optional features or operations unless specified otherwise. In addition, the sequence of operations (or steps) is not limited to the order presented in the figures and/or claims unless specifically indicated otherwise. Features described with respect to one figure or embodiment can be associated 30 with another embodiment or figure although not specifically described or shown as such.

It will be understood that when a feature or element is referred to as being "on" another feature or element, it can be directly on the other feature or element or intervening features and/or elements may also be present. In

contrast, when a feature or element is referred to as being "directly on" another feature or element, there are no intervening features or elements present. It will also be understood that, when a feature or element is referred to as being "connected", "attached" or "coupled" to another feature or element, it can be directly connected, attached or coupled to the other feature or element or intervening features or elements may be present. In contrast, when a feature or element is referred to as being "directly connected", "directly attached" or "directly coupled" to another feature or element, there are no intervening features or elements present. Although described or shown with respect to one embodiment, the features and elements so described or shown can apply to other embodiments. It will also be appreciated by those of skill in the art that references to a structure or feature that is disposed "adjacent" another feature may have portions that overlap or underlie the adjacent feature.

The terminology used herein is for the purpose of describing particular embodiments only and is not intended to be limiting of the invention. As used herein, the singular forms "a", "an" and "the" are intended to include the plural forms as well, unless the context clearly indicates otherwise. It will be further understood that the terms "comprises" and/or "comprising," when used in this specification, specify the presence of stated features, steps, operations, elements, and/or components, but do not preclude the presence or addition of one or more other features, steps, operations, elements, components, and/or groups thereof. As used herein, the term "and/or" includes any and all combinations of one or more of the associated listed items.

Spatially relative terms, such as "under", "below", "lower", "over", "upper" and the like, may be used herein for ease of description to describe one element or feature's relationship to another element(s) or feature(s) as illustrated in the figures. It will be understood that the spatially relative terms are intended to encompass different orientations of the device in use or operation in addition to the orientation depicted in the figures. For example, if a device in the figures is inverted, elements described as "under" or "beneath" other elements or features would then be oriented "over" the other elements or features. Thus, the exemplary term "under" can encompass both an orientation of over and under. The device may be otherwise oriented (rotated 90 degrees or at other orientations) and the spatially relative descriptors used herein interpreted

accordingly. Similarly, the terms "upwardly", "downwardly", "vertical", "horizontal" and the like are used herein for the purpose of explanation only unless specifically indicated otherwise.

5 It will be understood that although the terms first and second are used herein to describe various features/elements, these features/elements should not be limited by these terms. These terms are only used to distinguish one feature/element from another feature/element. Thus, a first feature/element discussed below could be termed a second feature/element, and similarly, a  
10 second feature/element discussed below could be termed a first feature/element without departing from the teachings of the present invention. Like numbers refer to like elements throughout.

Unless otherwise defined, all terms (including technical and scientific terms) used herein have the same meaning as commonly understood by one of ordinary skill in the art to which this invention belongs. It will be further  
15 understood that terms, such as those defined in commonly used dictionaries, should be interpreted as having a meaning that is consistent with their meaning in the context of the specification and relevant art and should not be interpreted in an idealized or overly formal sense unless expressly so defined herein. Well-known functions or constructions may not be described in detail for brevity  
20 and/or clarity.

The term "headset" includes any type of device or earpiece that may be attached to or near the ear (or ears) of a user and may have various configurations, without limitation. Headsets incorporating light-guiding earbuds as described herein may include mono headsets (one earbud) and stereo  
25 headsets (two earbuds), earbuds, hearing aids, ear jewelry, face masks, headbands, and the like.

The term "real-time" is used to describe a process of sensing, processing, or transmitting information in a time frame which is equal to or shorter than the minimum timescale at which the information is needed. For  
30 example, the real-time monitoring of pulse rate may result in a single average pulse-rate measurement every minute, averaged over 30 seconds, because an instantaneous pulse rate is often useless to the end user. Typically, averaged physiological and environmental information is more relevant than instantaneous changes. Thus, in the context of the present invention, signals may sometimes

be processed over several seconds, or even minutes, in order to generate a "real-time" response.

5 The term "monitoring" refers to the act of measuring, quantifying, qualifying, estimating, sensing, calculating, interpolating, extrapolating, inferring, deducing, or any combination of these actions. More generally, "monitoring" refers to a way of getting information via one or more sensing elements. For example, "blood health monitoring" includes monitoring blood gas levels, blood hydration, and metabolite/electrolyte levels.

10 The term "physiological" refers to matter or energy of or from the body of a creature (e.g., humans, animals, etc.). In embodiments of the present invention, the term "physiological" is intended to be used broadly, covering both physical and psychological matter and energy of or from the body of a creature. However, in some cases, the term "psychological" is called-out separately to emphasize aspects of physiology that are more closely tied to conscious or  
15 subconscious brain activity rather than the activity of other organs, tissues, or cells.

The term "body" refers to the body of a subject (human or animal) that may wear a headset incorporating one or more light-guiding earbuds, according to embodiments of the present invention.

20 In the following figures, various headsets and light-guiding earbuds for use with headsets will be illustrated and described for attachment to the ear of the human body. However, it is to be understood that embodiments of the present invention are not limited to those worn by humans.

25 The ear is an ideal location for wearable health and environmental monitors. The ear is a relatively immobile platform that does not obstruct a person's movement or vision. Headsets located at an ear have, for example, access to the inner-ear canal and tympanic membrane (for measuring core body temperature), muscle tissue (for monitoring muscle tension), the pinna and earlobe (for monitoring blood gas levels), the region behind the ear (for  
30 measuring skin temperature and galvanic skin response), and the internal carotid artery (for measuring cardiopulmonary functioning), etc. The ear is also at or near the point of exposure to: environmental breathable toxicants of interest (volatile organic compounds, pollution, etc.; noise pollution experienced by the ear; and lighting conditions for the eye. Furthermore, as the ear canal is naturally

designed for transmitting acoustical energy, the ear provides a good location for monitoring internal sounds, such as heartbeat, breathing rate, and mouth motion.

Wireless, Bluetooth®-enabled, and/or other personal communication headsets may be configured to incorporate physiological and/or environmental sensors, according to some embodiments of the present invention. As a specific example, Bluetooth® headsets are typically lightweight, unobtrusive devices that have become widely accepted socially. Moreover, Bluetooth® headsets are cost effective, easy to use, and are often worn by users for most of their waking hours while attending or waiting for cell phone calls. Bluetooth® headsets configured according to embodiments of the present invention are advantageous because they provide a function for the user beyond health monitoring, such as personal communication and multimedia applications, thereby encouraging user compliance. Exemplary physiological and environmental sensors that may be incorporated into a Bluetooth® or other type of headsets include, but are not limited to accelerometers, auscultatory sensors, pressure sensors, humidity sensors, color sensors, light intensity sensors, pressure sensors, etc.

Headsets, both mono (single earbud) and stereo (dual earbuds), incorporating low-profile sensors and other electronics, according to embodiments of the present invention, offer a platform for performing near-real-time personal health and environmental monitoring in wearable, socially acceptable devices. The capability to unobtrusively monitor an individual's physiology and/or environment, combined with improved user compliance, is expected to have significant impact on future planned health and environmental exposure studies. This is especially true for those that seek to link environmental stressors with personal stress level indicators. The large scale commercial availability of this low-cost device can enable cost-effective large scale studies. The combination of monitored data with user location via GPS data can make on-going geographic studies possible, including the tracking of infection over large geographic areas. The commercial application of the proposed platform encourages individual-driven health maintenance and promotes a healthier lifestyle through proper caloric intake and exercise.

Accordingly, some embodiments of the present invention combine a personal communications headset device with one or more physiological

and/or environmental sensors. Other embodiments may combine physiological and/or environmental sensors into a headset device.

Optical coupling into the blood vessels of the ear may vary between individuals. As used herein, the term "coupling" refers to the interaction or communication between excitation light entering a region and the region itself. For example, one form of optical coupling may be the interaction between excitation light generated from within a light-guiding earbud and the blood vessels of the ear. In one embodiment, this interaction may involve excitation light entering the ear region and scattering from a blood vessel in the ear such that the intensity of scattered light is proportional to blood flow within the blood vessel. Another form of optical coupling may be the interaction between excitation light generated by an optical emitter within an earbud and the light-guiding region of the earbud. Thus, an earbud with integrated light-guiding capabilities, wherein light can be guided to multiple and/or select regions along the earbud, can assure that each individual wearing the earbud will generate an optical signal related to blood flow through the blood vessels. Optical coupling of light to a particular ear region of one person may not yield photoplethysmographic signals for each person. Therefore, coupling light to multiple regions may assure that at least one blood-vessel-rich region will be interrogated for each person wearing the light-guiding earbud. Coupling multiple regions of the ear to light may also be accomplished by diffusing light from a light source within the earbud.

Embodiments of the present invention are not limited to headsets that communicate wirelessly. In some embodiments of the present invention, headsets configured to monitor an individual's physiology and/or environment may be wired to a device that stores and/or processes data. In some embodiments, this information may be stored on the headset itself. Furthermore, embodiments of the present invention are not limited to earbuds. In some embodiments, the light-guiding structure may be molded around another part of the body, such as a digit, finger, toe, limb, around the nose or earlobe, or the like. In other embodiments, the light-guiding structure may be integrated into a patch, such as a bandage that sticks on a person's body.

Referring to Fig. 1, a headset 10 according to some embodiments of the present invention is illustrated. The illustrated headset 10 includes a base

12, a headset housing 14, an earbud housing 16, and a cover 18 that surrounds the earbud housing 16. The base 12 includes a main circuit board 20 that supports and/or is connected to various electronic components. In the illustrated embodiment, a speaker 22, optical emitter 24, optical detectors 26, and thermopile 28 (described below) are mounted onto a secondary circuit board 32 which is secured to the main circuit board 20. The earbud housing surrounds the speaker 22, optical emitter 24, optical detectors 26, and thermopile 28. Collectively, the earbud housing 16, cover 18, and various electronic components (e.g., speaker 22, optical emitter 24, optical detectors 26, thermopile 28) located within the earbud housing 16 of the illustrated headset 10 may be referred to as an earbud 30. The headset housing 14 is secured to the base 12 and is configured to enclose and protect the various electronic components mounted to the base (e.g., main circuit board 20 and components secured thereto, etc.) from ambient interference (air, humidity, particulates, electromagnetic interference, etc).

Each optical detector 26 may be a photodiode, photodetector, phototransistor, thyristor, solid state device, optical chipset, or the like. The optical emitter 24 may be a light-emitting diode (LED), laser diode (LD), compact incandescent bulb, micro-plasma emitter, IR blackbody source, or the like. The speaker 22 may be a compact speaker, such as an inductive speaker, piezoelectric speaker, electrostatic speaker, or the like. One or more microphones, such as electrets, MEMS, acoustic transducers, or the like, may also be located within the headset housing or earbud housing to pick up speech, physiological sounds, and/or environmental sounds.

The main circuit board 20 and secondary circuit board 32 may also support one or more sensor modules (not shown) that contain various physiological and/or environmental sensors. For example, a sensor module, such as sensor module 70 illustrated in Figs. 12A-12B, may be attached to the circuit boards 20, 32. The circuit boards 20, 32 also may include at least one signal processor (not shown), at least one wireless module (not shown) for communicating with a remote device, and/or at least one memory storage device (not shown). An exemplary wireless module may include a wireless chip, antenna, or RFID tag. In some embodiments, the wireless module may include a low-range wireless chip or chipset, such as a Bluetooth® or ZigBee chip. These

electronic components may be located on the main circuit board 20, or on another circuit board, such as the secondary circuit board 32, attached to the main circuit board.

5 Secondary circuit board 32 may also include a temperature sensor, such as a thermopile 28 mounted thereto. The thermopile 28 is oriented so as to point towards the tympanic membrane within the ear of a subject wearing the headset 10 through the acoustic orifices 34a, 34b in the earbud housing 16 and cover 18, respectively. The secondary circuit board 32 may be in electrical contact with the main circuit board 20 via soldering, connectors, wiring, or the like. A battery 36, such as a lithium polymer battery or other portable battery, 10 may be mounted to the main circuit board 20 and may be charged via a USB charge port 38. Although not shown in Fig. 1, an ear hook may be attached to the base 12 or housing 14 to help stabilize the earbud 30 and headset 10 worn by a subject and such that the earbud 30 is consistently placed at the same 15 location within the ear canal of a subject.

In the illustrated embodiment, the earbud housing 16 is in acoustical communication with the speaker 22 and includes an aperture 34a through which sound from the speaker 22 can pass. However, additional apertures may also be utilized. The cover 18 also includes at least one aperture 20 34b through which sound from the speaker 22 can pass. The thermopile 28 is used as a heat sensor and measures thermal radiation from the ear of a subject via the acoustic apertures 34a, 34b. Additional or other sensors may be in the location of the thermopile 28, aligned towards the tympanic membrane, to sense other forms of energy, such as acoustic, mechanical, chemical, optical, or 25 nuclear energy from the tympanic membrane region. For example, a photodetector may replace the thermopile 28 to measure light scattering off the tympanic membrane.

The cover 18 includes light transmissive material in a portion 19 thereof that is referred to as a light-guiding region. The light transmissive 30 material in light-guiding region 19 is in optical communication with the optical emitter 24 and detectors 26. The light transmissive material in light-guiding region 19 is configured to deliver light from the optical emitter 24 into an ear canal of the subject at one or more predetermined locations and to collect light external to the earbud 30 and deliver the collected light to the optical detectors



26. As such, the earbud 30 of the illustrated headset 10 is referred to as a "light-guiding" earbud 30.

In some embodiments, the light transmissive material in the light-guiding region 19 may include a lens (e.g., lens 18L illustrated in Fig. 6). The lens 18L is in optical communication with the optical emitter 24 and/or with the optical detectors 26. For example, a lens 18L may be configured to focus light emitted by the optical emitter 24 onto one or more portions of an ear and/or to focus collected light on the light detectors 26. Lenses are described below with respect to Figs. 5-6.

In some embodiments, the earbud cover 18 may integrate a transparent light-guiding layer, wherein air is utilized as a cladding layer. For example, the earbud cover 18 may include an optically transparent silicone molded layer, and the earbud housing 16 may be removed such that a cladding layer is air. In some embodiments, the earbud housing 16 may be closed, and the light-guiding region 19 may be integrated within the cover 18 or between the housing 16 and cover 18.

The illustrated cover 18 of Fig. 1 includes an alignment member 40 (also referred to as a stabilization arm) that facilitates alignment of the earbud 30 within an ear canal of a subject. The alignment member 40 may facilitate stable measurements of optical scattered light from the ear region, which can be important for PPG measurements and tympanic temperature measurements.

In some embodiments, a light-guiding cover 18 is formed from a soft, resilient material, such as silicone, which deforms when inserted within an ear canal of a subject. However, various materials may be utilized for light-guiding covers 18 and for serving as light guides depending on the type of earbud desired for a particular use case, according to embodiments of the present invention. For example, in some embodiments, a light-guiding cover 18 may be formed from a substantially rigid material such that the light-guiding earbud 30 is substantially rigid. For example, for a running use case, the runner may wish to have firm but soft earbuds, such that the earbud may deform to some extent when inserted into the ear. In such case, the light-guiding region may be silicone or other soft material and the outer cladding may be air, a polymer, plastic, or a soft material having a lower index of refraction than silicone.

Fig. 2 illustrates a stereo headset 100 that utilizes two light-guiding earbuds 130, according to some embodiments of the present invention. The headset 100 also includes various sensor elements 132 located at several regions in the stereo headset 100. A benefit of the stereo headset 100 may be that the total number of sensors measuring the ear region may be doubled; alternatively, the sensors in each earbud may be halved. Another benefit of the stereo headset is that it may enable stereo music during daily activities. Another benefit of the stereo headset is that asymmetric physiological differences can be detected in the user by measuring each side of the user in real-time. For example, differences in blood flow between right and left sides of a user may be detected, indicating changes in right/left brain activity, the onset of a stroke, localized inflammation, or the like.

Light-guiding earbuds according to various embodiments of the present invention will now be described with respect to Figs. 3, 4A-4D, 5, 6, 7A-7B, 8A-8D, 9A-9B, and 11A-11B. Referring initially to Figs. 3-4, a light-guiding earbud 30 includes a base 50, an earbud housing 16 extending outwardly from the base 50 that is configured to be positioned within an ear E of a subject, and a cover 18 that surrounds the earbud housing 16. The earbud housing 16 is in acoustical communication with a speaker 22 and includes at least one aperture 34a through which sound from the speaker 22 can pass. The cover 18 includes at least one aperture 34b through which sound from the speaker 22 can pass, and includes light transmissive material in optical communication with an optical emitter 24 and detector 26.

The cover 18 includes cladding material 21 on an inner surface 18b thereof and on an outer surface 18a thereof, as illustrated. An end portion 18f of the cover outer surface 18a does not have cladding material. As such, the cover 18 serves as a light guide that delivers light from the optical emitter 24 through the end portion 18f and into the ear canal C of a subject at one or more predetermined locations and that collects light external to the earbud housing 16 and delivers the collected light to the optical detector 26. In the various embodiments described herein, the terms light guide and cover are intended to be interchangeable. However, it should be noted that, in other embodiments, the earbud housing 16 may also serve as a light guide without the need for cover 18.

The base 50 in all of the earbud embodiments (Figs. 3, 4A-4D, 5,

6, 7A-7B, 8A-8D, 9A-9B, and 11A-11B) described herein may include any combination of a printed circuit board, electrical connectors, and housing component for a headset. For example, the base 50 in Figs. 3-6, 7A-7B, 8A-8D, 9A-9B, and 11A-11B, may include, for example, the base 12 of the headset 10 of Fig. 1, the main circuit board 20 of the headset 10 of Fig. 1, the housing 14 of the headset 10 of Fig. 1, or may be a combination of the base 12, main circuit board 20, and/or housing 14 of the headset 10 of Fig. 1.

The optical emitter 24 generates inspection light 111 and the light-guiding region 19 of the light guide 18 directs the inspection light 111 towards an ear region. This light is called inspection light because it interrogates the surface of the ear, penetrates the skin of the ear, and generates a scattered light response 110 which may effectively inspect blood vessels within the ear region. The optical detector 26 detects scattered light 110 from an ear region and the light-guiding region 19 of the light guide 18 guides the light to the optical detector 26 through the light-guiding region 19, as illustrated.

In the embodiment of Fig. 3, the light-guiding earbud 30 is configured for optical coupling that is parallel to the light guide (i.e., cover 18). The optical detector 26 and optical emitter 24 are configured to detect and generate light substantially parallel to the light-guiding region 19 of the light guide 18. For example, the light guide 18 defines an axial direction  $A_1$ . The optical emitter 24 and optical detector 26 are each oriented such that their respective primary emitting and detecting planes  $P_1$ ,  $P_2$  are each facing a respective direction  $A_3$ ,  $A_2$  that is substantially parallel with direction  $A_1$ .

The light guiding region 19 of the light guide 18 in the illustrated embodiment of Fig. 3 is defined by cladding material 21 that helps confine light within the light guiding region 19. The cladding material 21 may be reflective material in some embodiments. In other embodiments, the cladding material may be optically transparent or mostly transparent with a lower index of refraction than the light transmissive material of the cover 18. The cladding 21 may be a layer of material applied to one or more portions of the inner and/or outer surfaces 18a, 18b of the light guide 18. In some embodiments, the outer surface 16a of the earbud housing 16 may serve as cladding that confines light within the light-guiding region 19. In some embodiments, the light transmissive material of the light guide 18 may be composed of a material having a higher index of

refraction than the cladding material 21. In some embodiments, air may serve as a cladding layer.

In the embodiment of Fig. 4A, the light-guiding earbud 30 is configured for optical coupling that is substantially perpendicular to the light guide (i.e., cover 18). The optical detector 26 and optical emitter 24 are configured to detect and generate light substantially perpendicular to the light-guiding region 19 of the light guide 18. For example, the light guide 18 defines an axial direction  $A_1$ . The optical emitter 24 and optical detector 26 are each oriented such that their respective primary emitting and detecting planes  $P_1$ ,  $P_2$  are each facing a respective direction  $A_3$ ,  $A_2$  that is substantially perpendicular to direction  $A_1$ . The orientation of the optical emitter 24 and optical detector 26 in Fig. 4A may be convenient for manufacturing purposes, where side-emitting LEDs and side-detecting photodetectors can couple directly to the light-guiding region 19 for generating light 111 and detecting light 110. This may relax size constraints for an earbud 30 because the dimensions of the light-guiding region 19 may be independent of the optical emitter 24 and optical detector 26.

Fig. 4B illustrates the light-guiding earbud 30 of Fig. 4A modified such that the earbud cover 18 and cladding material 21 are elongated to reach deeper within the ear canal C of a subject, and closer to the tympanic membrane, for example. In the illustrated embodiment of Fig. 4B, there are no apertures in the housing 16 or cover 18. Acoustic energy 44 from/to the speaker/microphone passes through the material of the cover 18 and housing 16. The illustrated elongated configuration serves as both an optical light-guiding region and an acoustic wave-guiding region.

Fig. 4C illustrates the light-guiding earbud 30 of Fig. 4A modified such that the earbud cover 18 and cladding material 21 are elongated to reach deeper within the ear canal C of a subject, and closer to the tympanic membrane, for example. In the illustrated embodiment of Fig. 4C, apertures 34a, 34b in the housing 16 and cover 18 are provided. As such, the optical light-guiding region 19 and the acoustic wave-guiding region 54 are isolated from each other. The light-guiding region 19 may be a light transmissive material, such as a dielectric material, and the acoustic wave-guiding region 54 may be air or another material, and the separation between these regions may be defined by at least part of the cladding material 21. Embodiments of the present

invention may include multiple openings 34a, 34b in the housing 16 and cover 18. The separation between the light-guiding region 19 and the acoustic wave-guiding region 54 may be defined by other structures composed of a variety of possible materials. Specific examples of these materials include plastic molding, metals, polymeric structures, composite structures, or the like.

Fig. 4D illustrates the light-guiding earbud 30 of Fig. 4A modified such that the earbud cover 18 and cladding material 21 are elongated to reach deeper within the ear canal C of a subject, and closer to the tympanic membrane, for example. In the illustrated embodiment of Fig. 4D, the area within the housing 16 may be air, silicone, plastic, or any material capable of passing sound. As such, at opening 34b, an interface exists between the material of the light-guiding region 19 and the material within the housing 16. In some embodiments, the light-guiding region 19 and the region within the housing 16 may both be air. In other embodiments, the light-guiding region 19 and the region within the housing 16 may be formed from the same or different materials. In some embodiments, the region within the housing 16 may be formed from an optical wave guiding material identical or similar to the material in the light-guiding region 19.

In the embodiments of Figs. 4B-4D, the optical energy 110 coming from the ear may include optical wavelengths, such as IR wavelengths, emitting from the tympanic membrane due to black body radiation. If the optical detector 26 is configured to measure this black body radiation, then the earbud can be used to measure tympanic temperature, blood analyte levels, neurological, electrical activity, or metabolic activity of the earbud wearer.

Referring to Fig. 5, a light-guiding earbud 30 is configured for optical coupling that is parallel to the light guide (i.e., cover 18) as in the embodiment of Fig. 3. However, the embodiment of Fig. 5 does not include a separate earbud housing. Instead, the light guide 18 serves the function of the earbud housing. In addition, the light guide 18 includes multiple windows 18w formed in the cladding material 21 on the outer surface 18a of the cover and through which light 111 emitted by the light emitter 24 passes and multiple windows 18w through which scattered light 110 passes into the light guide 18 to be directed to the light detector 26. These openings 18w may extend circumferentially around the light guide 18 or may partially extend

circumferentially around portions of the light guide 18. In some embodiments of this invention, the earbud housing and light guide 18 may be separated, as shown in other figures.

5 In addition, the illustrated light guide 18 of Fig. 5 is surrounded by a layer 29 of light transmissive material. One or more lenses 29L are formed in this layer 29 and are in optical communication with respective windows 18w in the light guide 18. In the illustrated embodiment, a lens 29L is in optical communication with a respective window 18w through which emitted light 111 passes, and a respective window 18w through which scattered light 110 passes.  
10 Lenses 29L are configured to focus inspection light 111 onto a particular region of the ear. Lenses 29L are configured to help collect scattered light 110 and direct the scattered light 110 into the light guiding region 19. In some embodiments, these lenses 29L may be a molded part of the light guide 18. The illustrated location of lenses 29L in Fig. 5 is non-limiting, and the lenses 29L may  
15 be located wherever optical coupling between the earbud and ear is desired. Though convex lens embodiments are shown in Fig. 5, this is not meant to limit embodiments of the present invention. Depending on the desired optical coupling and configuration of the earbud against the ear, a variety of lens types and shapes may be useful, such as convex, positive or negative meniscus,  
20 planoconvex, planoconcave, biconvex, biconcave, converging, diverging, and the like.

Referring now to Fig. 6, a light guiding earbud 30, according to some embodiments of the present invention, includes a base 50, an earbud housing 16 extending outwardly from the base 50 that is configured to be  
25 positioned within an ear E of a subject, and a cover 18 of light transmissive material surrounding the earbud housing 16 that forms a light-guiding region 19. The earbud housing 16 is in acoustical communication with a speaker 22 and includes at least one aperture 34a through which sound from the speaker 22 can pass. The earbud housing 16 encloses the speaker 22, an optical emitter 24 and  
30 an optical detector 26 as illustrated. An additional light detector 26 is located on the base 50 but is not surrounded by the earbud housing 16.

The earbud housing 16 is formed of a cladding material. The cladding material may be reflective material in some embodiments. In other embodiments, the cladding material may be optically transparent or mostly

transparent with a lower index of refraction than the light transmissive material of the cover 18. In some embodiments, the earbud housing 16 may be replaced by air, such that the cladding region is air. Air may have a smaller index of refraction than that of the cover 18, supporting light transmission along the cover 18. In  
5 other embodiments, a cladding region exists between the earbud housing 16 and the light-guiding region 19. In another embodiment, a cladding region exists covering the outside of light-guiding region 19, with the exception of regions surrounding the lens regions 18L.

A plurality of windows 16w are formed in the earbud housing 16 at  
10 selected locations to permit light emitted by the light emitter 24 to pass therethrough. In some embodiments, the earbud housing 16 may have translucent or transparent material that serves the function of one or more windows 16w. The cover 18 includes a plurality of lenses 18L that are in optical communication with respective windows 16w in the earbud housing 16. These  
15 lenses 18L are configured to focus light 111 passing through a respective window 16w towards a particular region of the ear of a subject, and to help collect scattered light 110 and direct the scattered light 110 into the earbud housing 16 towards the light detector 26.

The earbud 30 of Fig. 6, via the locations of windows 16w,  
20 produces isotropic optical coupling, such that the light generated by the optical emitter 24 is roughly identical in all directions with respect to the earbud housing 16. The inspection light 111 generated by the optical emitter 24 passes isotropically into the light guiding region 19 through the windows 16w.

A benefit of light guiding earbud 30 of Fig. 6 is that manufacturing  
25 may not require alignment of the light-guiding region 19 with respect to the optical emitter 24 and detector 26. This may be in part because the optical energy density generated/detected by the optical emitter/detector may be the same, or relatively uniform, within the earbud housing 16 regardless of alignment of the light guide 18 with respect to the earbud housing 16 or regardless of  
30 alignment between the optical emitters/detectors and the earbud housing 16. This effect may be similar to that observed in "integrating spheres" commonly used for quantifying the lumen output of an optical source. Namely, because the light from the optical emitter 24 may be substantially isotropic and not focused, there is less restriction on the alignment of the earbud housing and earbud cover

with respect to the optical emitter 24 or optical detector 26.

Referring now to Figs. 7A-7B, a light guiding earbud 30, according to some embodiments of the present invention, includes a base 50, and an earbud housing 16 extending outwardly from the base 50 that is configured to be positioned within an ear E of a subject. The earbud housing 16 is formed from translucent material such that light can pass therethrough and forms a light-guiding region 19. The earbud housing 16 is in acoustical communication with a speaker 22 and includes at least one aperture 34a through which sound from the speaker 22 can pass. A pair of optical detectors 26 are secured to the base 50 but are not surrounded by the earbud housing 16, as illustrated.

The earbud housing 16 includes a flexible optical emitter 24 integrally formed within the housing 16, as illustrated. The optical emitter 24 is flexible such that it may be positioned around the earbud in an earbud form-factor. The flexible optical emitter 24 is configured to be conformable to an earbud shape and configuration. The flexible optical emitter 24 may be in, near, or part of the earbud housing 16, cladding material 21, or housing 16. In some embodiments, the flexible optical emitter 24 may be part of a flexible optical circuit inserted into an earbud 30.

The optical detectors 26 positioned outside the earbud housing 16 of the earbud 30 of Figs. 7A-7B collect scattered light from an ear originating from inspection light 111 generated by the flexible optical emitter 24. The flexible optical emitter 24 may be mounted to the earbud base 50 through one or more electrical connectors 24a. In some embodiments, these may be soldered, wired, or detachable connectors. In some embodiments, the flexible optical emitter 24 may include a flexible optical detector. In some embodiments, the flexible optical emitter 24 may be part of a flexible optical circuit comprising the form-factor of 24 shown in Figs. 7A-7B, where the flexible optical circuit may include one or more optical emitters and detectors as well as amplifiers, microprocessors, wireless circuitry, and signal conditioning electronics. In some embodiments, the flexible optical circuit may include a complete chipset for physiological and environmental detection and for wired/wireless transfer of data to a remote location. For example, these flexible devices may include an organic LED (OLED) and an organic optical detector circuit. This embodiment may be useful for generating a diffuse light beam towards the ear region and for detecting a



diffuse optical scatter response from the ear region. In some embodiments, the emitter and detector on the flexible optical emitter 24 may be a traditional light-emitting diode (LED) and photodetector (PD) integrated onto a flexible printed circuit board. In other embodiments, transparent solid state optical emitters, detectors, or switches may be used. For example, an electrically controlled liquid crystal matrix may be embedded within an earbud, covering the flexible optical emitter 24. This may allow localized control of light flow to selected areas from/to the earbud going towards/away-from the ear. Additionally, this may allow localized control of light wavelength to selected areas.

Referring now to Figs. 8A-8B, a light guiding earbud 30, according to some embodiments of the present invention, includes a base 50, an earbud housing 16 extending outwardly from the base 50 that is configured to be positioned within an ear of a subject, and a cover 18 that surrounds the earbud housing 16. The earbud housing 16 is in acoustical communication with a speaker 22 and includes at least one aperture 34a through which sound from the speaker 22 can pass. The cover 18 includes at least one aperture 34b through which sound from the speaker 22 can pass. The cover 18 includes a cladding material 21 on the outer surface 18a thereof, except at end portion 18f, as illustrated. In the illustrated embodiment, there is no cladding material on the cover inner surface 18b. The housing 16 is in contact with the cover inner surface 18b and serves as a cladding layer to define the light guiding region 19. The cover 18 with the illustrated cladding material 18c serves as a light guide that delivers light from the optical emitters 24 into an ear canal of a subject through cover end portion 18f. The cover 18 also collects light through end portion 18f and delivers the collected light to the optical detectors 26. Various configurations and arrangements of optical emitters and detectors may be utilized in accordance with embodiments of the present invention.

In the illustrated embodiment of Figs. 8A-8B, to reduce the risk of the inspection light 111 interrogating and saturating the optical detectors 26, a bottom portion 16a of the earbud housing 16 includes a light blocking region that blocks light from passing therethrough. This light blocking region 16a may be a black-painted region, an optically opaque region, or a material or structure that blocks light transmission. The illustrated configuration of the earbud housing 16 and bottom portion 16a may help confine inspection light 111 generated by the

optical emitters 24 within the light-guiding layer (i.e., 19), guiding this light towards the ear region through the end portion 18f of the earbud 30.

In some embodiments, as illustrated in Fig. 8C, the earbud housing 16 may be at least partially reflective to scatter light within the cavity defined by the earbud housing 16. In such case, the optical energy 111 may exit the earbud 30 through apertures 34a, 34b in the housing 16 and cover 18. An advantage of this configuration is that light 111 can be focused on a particular region of the ear where a particular physiological activity may be located. Also, this configuration may reduce unwanted optical signals from regions that may not be relevant to the physiological activity of interest. Although Fig. 8C shows the apertures 34a, 34b positioned toward the tympanic membrane, the apertures 34a, 34b may be located at one or more other locations about the earbud 30. For example, an aperture may be formed in the housing 16 and cover 18 at the location where the earbud 30 contacts the antitragus of an ear to allow optical energy 111 to interrogate the antitragus region of the ear.

In some embodiments, as illustrated in Fig. 8D, the earbud housing 16 may contain a material that reflects one or more wavelengths of light and transmits one or more wavelengths of light. For example, the earbud housing 16 may be comprised of a polymer, plastic, glass, composite material, or resin that reflects visible wavelengths and transmits IR wavelengths. Exemplary materials include color absorbing materials, such as organic dyes, found in photographic film. Alternatively, the earbud housing 16 may include an optical filter region, such as a Bragg filter or other optical filter layer deposited on one or more sides of the housing region. If an optical detector 26' is configured to measure visible wavelengths only, then the optical energy detected by optical detector 26' may consist primarily of optical energy scattered from the earbud housing 16, and the optical energy detected by the optical detectors 26 may consist of optical energy scattered from the ear region. This configuration may be useful because the signal from the optical detector 26' may represent motion noise which may be removed from the signal derived from the optical detectors 26, which may contain physiological information and motion noise.

Referring now to Figs. 9A-9B, a light guiding earbud 30, according to some embodiments of the present invention, includes a base 50, an earbud housing 16 extending outwardly from the base 50 that is configured to be

positioned within an ear of a subject, and a cover 18 surrounding the earbud housing 16. The earbud housing 16 is in acoustical communication with a speaker 22 and includes at least one aperture 34a through which sound from the speaker 22 can pass. The cover 18 includes at least one aperture 34b through which sound from the speaker 22 can pass. A pair of optical emitters 24 are secured to the base 50 and are surrounded by the earbud housing 16, as illustrated. An optical detector 26 is secured to the base 50 and is not surrounded by the earbud housing 16, as illustrated. The cover 18 serves as a light guide that delivers light from the optical emitters 24 into an ear canal of a subject.

The light-guiding region 19 of the cover 18 is designed to diffuse light and/or to generate luminescence. In this embodiment, the light-guiding region 19 includes at least one optical scatter or luminescence region. The optical scatter or luminescence region may be located anywhere within the earbud in the optical path of the optical emitters 24, but preferably within or about the cladding layer itself. When inspection light 111 generated by the optical emitters 24 is scattered or by an optical scatter region, this light may form a more diffuse optical beam 111a that is more uniform across the earbud 30 than the inspection light 111 generated by the optical emitters 24. This diffused beam, having an intensity distribution being less sensitive to motion of the ear, may be useful in alleviating motion artifacts in the scattered light coming from the ear, such that the scattered light coming from the ear, measured by the optical detector 26, is more indicative of blood flow changes within blood vessels and less indicative of mouth movements and body motion. The optical scatter region within the light-guiding region 19 may be at least partially comprised of impurities or morphological differences within the light-guiding region. An example of such impurities may include point defects, volume defects, native defects, metallics, polymers, microspheres, phosphors, luminescent particles, air pockets, particles, particulate matter, and the like. An example of morphological differences may include density variations, roughness, air pockets, stoichiometry variations, and the like. As a specific example, the light-guiding region 19 may comprise a transparent material, such as glass, a polymer, or silicone, and a luminescent impurity, such as a phosphor or luminescent polymer or molecule, may be integrated within the light-guiding region. This configuration may generate

luminescence within the light-guiding region 19 in response to optical excitation from the optical emitters 24. In other embodiments, nanoscale fluctuations or impurities may be used to diffuse or manipulate light through the earbud.

5 Examples of nanoscale fluctuations or impurities may include quantum dots, rods, wires, doughnuts, or the like.

Fig. 9C illustrates an exemplary homogeneous distribution of luminescent particles 44, such as phosphors, embedded within the earbud cover 18, according to some embodiments of the present invention. Figs. 9D-9E illustrate an exemplary distribution of luminescent particles 44, such as  
10 phosphors, where the particles are distributed near one or more surfaces of the earbud cover 18, according to some embodiments of the present invention.

In another embodiment, an optical scatter or luminescent region may be at least partially located in a separate region from the light-guiding region 19, such as a coating, that may be in physical contact with the light-guiding  
15 region 19.

In another embodiment, the optical scatter region or luminescent region may include multiple layers of light-guiding material having at least one dissimilar optical property, such as a dissimilar index of refraction, transparency, reflectivity, or the like. In another embodiment, the optical scatter region may  
20 include one or more patterned regions having at least one dissimilar optical property.

In another embodiment, the optical scatter or luminescent region may be distributed at select locations throughout the earbud.

Fig. 10 illustrates relevant anatomy of a human ear E. Blood  
25 vessels are located across the ear, but it has been discovered that photoplethysmography (PPG) signals are the strongest near the antitragus, tragus, lobule, and portions of the acoustic meatus, and the ear canal. The antitragus is a particularly attractive location for photoplethysmography because a strong PPG signal can be derived with minimal motion artifacts associated with  
30 running and mouth motion.

Referring now to Figs. 11A-11B, a light guiding earbud 30, according to some embodiments of the present invention, includes a base 50, an earbud housing 16 extending outwardly from the base 50 that is configured to be positioned within an ear of a subject, and a cover 18 surrounding the earbud

housing 16. The earbud housing 16 is in acoustical communication with a speaker 22 and includes at least one aperture 34a through which sound from the speaker 22 can pass. The cover 18 includes at least one aperture 34b through which sound from the speaker 22 can pass. The cover 18 serves as a light guide for directing light into an ear of a subject and defines a light-guiding region 19. The illustrated earbud 30 is configured to focus light towards the antitragus of the ear of a human. In the illustrated embodiment, there is no cladding material on the outer surface 18a or inner surface 18b of the cover 18. Air serves as a cladding layer at the outer surface 18a and the housing 16 serves as a cladding layer at the inner surface 18b. Air may serve as a sufficient cladding layer due to the index of refraction difference between air and the light guiding layer. Namely, the index of refraction of the light-guiding layer 19 may be more than that of air.

A sensor module 70 is located near the earbud periphery, as illustrated. This sensor module 70 is shown in more detail in Figs. 12a-12B, and is described below. Three benefits of locating the sensor module 70 near the periphery of the light-guiding earbud 30 are: 1) PPG signals near the antitragus are less corrupted by motion artifacts than are PPG signals in other blood-vessel-rich regions of the ear; 2) the sensor module 70 may be designed somewhat independently of the earbud 30, liberating earbud comfort maximization from PPG signal maximization; and 3) because design constraints may be liberated, sensors need not be located in the acoustic cavity (i.e., within the earbud housing 16), allowing sound to pass through the acoustic orifices 34a, 34b with minimal interference. In this embodiment, it may be beneficial to incorporate lenses within the cover 18, similar to the lenses 18L of Fig. 6. It may be beneficial to extend the light-guiding region 19 of the cover 18 near the location where the earbud 30 rests near the antitragus. This light-guide extension 19a serves as an additional light-coupling region and may improve optical coupling from the light-guiding region 19 to an ear region and/or improve optical coupling from an ear region to the light-guiding region 19, including the antitragus and portions of the acoustic meatus. This is because this extended light-guiding region 19a may provide skin contact between the light guiding layer 19 and the skin, providing better optomechanical stability and optical coupling. In this embodiment, light may couple into the extended light-guiding region 19a, from an optical emitter 24, and into the ear region. Similarly, light may couple

from the ear region, into the extended light-guiding region 19a, and to the optical detector 26. This extended light-guiding region 19a may appear as a bulb or lens near the bottom of the earbud cover 18.

5 Figs. 12A-12B illustrate respective opposite sides of a sensor module 70 that may be located near the periphery of an earbud 30, for example as illustrated in Figs. 11A-11B, according to some embodiments of the present invention. Sensor module 70 may include a number of electronic components capable of converting various forms of energy into an electrical signal and digitizing the signal. For example, the sensor module 70 may include light-  
10 emitting diodes, optical sensors, accelerometers, capacitive sensors, inertial sensors, mechanical sensors, electromagnetic sensors, thermal sensors, nuclear radiation sensors, biological sensors, and the like. In some embodiments, the optical emitters of this invention may be a combination of side-emitting, edge-emitting, or surface-emitting light-emitting diodes (LEDs) or laser diodes (LDs).

15 In the illustrated embodiment of Figs. 12A-12B, the sensor module 70 includes two sets of optical emitters 24a, 24b. The first set of optical emitters 24a may be side-emitters (or edge-emitters) that are located at the top of the module 70 and direct light towards the earbud tip (e.g., cover end portion 18f, Fig. 8A) and towards the acoustic meatus and/or ear canal of the ear. The  
20 second set of optical emitters 24b may be located near the middle of the module 70 and may direct light in a beam that is largely perpendicular to that of the side-emitters 24a. In this particular embodiment, a single optical emitter 24b is shown mounted on a circuit board 70c such that this optical emitter 24b directs light towards the antitragus, which is located largely perpendicular to the acoustic  
25 meatus.

The optical energy generated by these optical emitters 24a, 24b may be scattered by blood vessels in the ear. This scattered light may be at least partially captured by the optical detectors 26. This light may be digitized by an optical detector 26 itself or with other circuitry on the sensor module circuit board  
30 70c. The light-guiding design of the aforementioned light-guiding earbuds 30 may direct light towards each of these detectors 26. For example, this may be accomplished via the light-guiding earbud 30, wherein a lens (e.g., 18L, Fig. 6) facilitates inspection light coupling from the optical emitters 24 into the ear region and facilitates scattered light coupling to the optical detectors 26 from the ear

region. Additional sensor components 27a, 27b may be used to measure an orthogonal energy component, facilitate sensor analysis, and thus help generate physiological assessments. For example, sensor components 27a, 27b may be thermal sensors for measuring the temperature of the inner ear (using the thermal sensors 27a facing the ear region) with respect to the outer ear (using the thermal sensor 27b facing away from the ear region). By subtracting the two measured digitized temperatures from these two sensors 27a, 27b, an indication of heat flow from the ear can be generated. This temperature differential may be mathematically related to metabolic rate. For example, this temperature differential may be directly proportional metabolic rate. These temperature sensors may include thermistors, thermopiles, thermocouples, solid state sensors, or the like. They may be designed to measure thermal conduction, convection, radiation, or a combination of these temperature components.

The earbud-facing side (Fig. 12B) of the sensor module 70 may include sensors that do not need to be located on the antitragus-facing side of the sensor module. For example, one or more inertial sensors 27c may be located on the earbud-facing side (Fig. 12B) of the sensor module 70. In a particular embodiment, the inertial sensor 27c may be a 3-axis accelerometer, and because this sensor does not need to optically couple with the ear region, a better use of sensor real estate may be to locate this sensor on the earbud-facing side of the sensor module 70. Additional optical emitters 24a, 24b may be located on the earbud-facing side to facilitate an optical noise reference. Namely, as the person wearing the earbud module 30 moves around, the interrogation light generated by the optical emitters 24a, 24b may be scattered off the earbud and be detected by optical detectors 27d. This scattered light intensity, phase, and/or frequency due to body motion may be proportional to the motion-related component of the scattered light intensity from the ear region. The motion-related component is the component due to the physical motion of the ear and not the component related to blood flow. Thus, the optical scatter signal collected by the detectors 27d may provide a suitable noise reference for an adaptive filter to remove motion artifacts from the scattered light from the ear region, generating an output signal that is primarily related to blood flow (which may be the desired signal). In the same token, the scattered light reaching the optical detectors 27d may be used to generate a measure of activity. The intensity,

phase, and frequency of this scattered light may be related to physical activity. Sinusoidal variations of the heart rate waveform may be counted digitally, by identifying and counting crests and peaks in the waveform, to generate an effective step count. Embodiments of the present invention, however, are not  
5 limited to the illustrated location of components in the sensor module 70. Various types and orientations of components may be utilized without limitation.

Fig. 19 illustrates the optical interaction between the sensor module 70 of Figs. 12A-12B and the skin of a subject. The sensor module 70 is shown in a reflective pulse oximetry setup 80 where reflected wavelengths 110  
10 are measured, as opposed to measuring transmitted wavelengths. The optical emitter and optical detector wavelengths for pulse oximetry and photoplethysmography may include ultraviolet, visible, and infrared wavelengths. In the illustrated embodiment, an optical source-detector assembly 71 is integrated into sensor module 70 to generate optical wavelengths 111 and  
15 monitor the resulting scattered optical energy 110. The optical source-detector assembly 71 contains one or more optical sources emitting one or more optical wavelengths, as well as one or more optical detectors detecting one or more optical wavelengths.

The epidermis 90, dermis 91, and subcutaneous 92 layers of skin  
20 tissue are shown in Fig. 19 for reference. The scattered optical energy 110 may be modulated in intensity by changes in blood flow in the blood vessels, changes in physical motion of the body, respiration, heart rate, and other physiological changes. In some cases, the scattered optical energy may be luminescent energy from the skin, blood, blood analytes, drugs, or other materials in the  
25 body.

As previously described, the optical scatter signal collected by the detectors 27d may provide a suitable noise reference for an adaptive filter to remove motion artifacts from the scattered light from the ear region, generating an output signal that is primarily related to blood flow (which may be the desired  
30 signal). This is because light detected by these detectors would come from light that has not been scattered by a physiological region but rather light that has been scattered from a region of the associated earpiece that may move along with the ear. Thus, the scattered light reaching the optical detectors 27d may be used to generate a measure of activity.



Fig. 13 illustrates the basic configuration of an adaptive noise cancellation scheme 200 for extracting a physiological signal from noise. The two types of sensor inputs are represented by the terms "Channel A" and "Channel B". Channel A refers to inputs from sensors that collect physiological information plus noise information, and Channel B refers to inputs from sensors that collect primarily (or substantially) noise information. Channel B information is passed through an electronic filter 203 whose properties are updated adaptively and dynamically. The filter 203 properties are updated to minimize the difference between Channel A and the post-processed Channel B, denoted as  $B^{\wedge}$ . In this way, noise is removed from Channel A and Channel C contains predominantly physiological information from which parameters such as blood flow, heart rate, blood analyte levels, breathing rate or volume, blood oxygen levels, and the like may be calculated. It is important to note that the Channel A information can still be useful despite the presence of noise, and the noise information may still be utilized for the computation of relevant parameters. For instance, the residual noise information in Channel A may be extracted by a parameter estimator 201 and the output in Channel D may be one or more activity assessments or the like. Similarly, the raw noise channel, Channel B, may be post-processed by a parameter estimator 205 to extract activity assessments for Channel E. Activity assessments may include exertion, activity level, distance traveled, speed, step count, pace, limb motion, poise, performance of an activity, mastication rate, intensity, or volume, and the like. The noise cancellation scheme 200 may be integrated into the firmware of a microprocessor or the like.

Although the embodiment of Fig. 13 for cancelling motion noise has been presented for an earbud configuration, this does not limit the invention to earbuds. An element of the adaptive noise cancellation scheme 200 for cancelling motion noise with an optical noise source may be that the optical detectors (such as 27d) are configured such that they do not receive scattered light from a physiological region while the detectors are simultaneously receiving scattered light from a region that is moving in synchronization with the physiological region. Even the slightest physiological signal existing in the optical noise reference of Channel B may prevent the adaptive filter from working properly such that the physiological signal may inadvertently be removed altogether by the filter 203. Furthermore, although the noise source Channel B is

described as an optical noise source, other forms of energy may be used in this invention. Namely, any inertial sensor input may constitute the input for Channel B. More specifically, a sensor for measuring changes in capacitance along the earbud with respect to the ear may provide an inertial noise reference without also measuring physiological information. Similarly, an accelerometer may provide an inertial noise reference without also measuring physiological information. An inductive sensor may also provide an inertial noise reference without also measuring physiological information. For each noise source, a defining element may be that the noise source may be configured to measure physical motion only (or mostly) and not physiological information (such as blood flow, blood oxygen, blood pressure, and the like). The utility of an optical noise source is that because the optical signal Channel A and the optical noise Channel B have the same linearity response, the adaptive filter scheme 200 may be more effective than the case where the signal and noise channels operate via different forms of sensed energy. For example, the response linearity characteristics of an accelerometer sensor in response to inertial changes may not be the same as the response linearity characteristics of an optical sensor.

The adaptive noise cancellation scheme 200 for cancelling motion noise with an optical source (specifically an infrared LED) has been demonstrated in the laboratory, with a human wearing a light-guiding earbud while resting, jogging, and running over a treadmill, and various data summaries 300a-300d are presented in Figs. 14A-14D. The data was recorded by a chip and memory card embedded in an earbud 30, having electrical connectivity with the sensor module 70 within the earbud 30. The raw signal in low motion 300a and raw signal in high motion 300c may be equated with the signal of Channel A of Fig. 13. Similarly, the "blocked channel" in low motion 300b and "blocked channel" in high motion 300d may be equated with Channel B of Fig. 13. In this experiment, the "block channel" consisted of an optical noise source, wherein the optical noise source included an optical emitter-detector module such as 70 of Figs. 12A-12B. However, instead of being exposed to the ear, the optical emitter-detector module was covered with a layer of clear silicone that was then covered by black tape to prevent light from the emitter (such as 24a and 24b) from reaching the ear. Thus, scatter from the black tape was scattered back to the emitter-detector module through the silicone and sensed as motion noise by

the detectors (such as 26 and 27d). In a sense, for this configuration, the optical channel to the human ear is "blocked", hence the term "blocked channel". The purpose of the clear silicone below the black tape was to: 1) provide an unobstructed, transparent optical scatter path for the IR light and 2) provide motion sensitivity similar to that of human skin, as silicone has a vibration response that may be similar to that of human skin.

Figs. 14A-14D show that the raw signal in low motion 300a indicates blood flow pulses which can be translated as heart rate. This is because each blood flow pulse represents one heart beat. However, the raw signal in high motion 300c indicates measured mostly physical activity. This is evident by the fact that the high motion signal 300c matches the corresponding blocked channel signal 300d, and the blocked channel in high motion 300d was found to have a substantially identical beat profile with the measured steps/second of the runner.

Fig. 15 is a graph of processed physiological signal data from a headset having one or more light-guiding earbuds 30, according to some embodiments of the present invention. Specifically, Fig. 15 shows the analysis results 400 of the data summaries 300a-300d presented in Figs. 14A-14D of blood flow (y-axis) versus time (x-axis) following two data processing sequences to extract heart rate. One sequence incorporated the adaptive filtering process 200 of Fig. 13 as well as a beat finder processing step. The second sequence incorporated the beat finder processing step without the adaptive filtering process 200 of Fig. 13. The beat finder process counts each heart beat by monitoring the peaks and valleys of each pulse, such as the peaks and valleys shown in the graph 300a of Fig. 14A. As shown in Fig. 15, the beat finder was effective at measuring heart rate during resting and jogging. However, the beat finder alone was not sufficient for monitoring heart rate during running. This is because at high motion, the signal 300d (Fig. 14D) associated with footsteps is strong enough to overwhelm the smaller signal associated with heart rate, and so the motion-related contribution dominated the overall signal 300d. Thus, the beat finder cannot distinguish heart beats from footsteps. By employing the adaptive filtering process 200 (Fig. 13) before the beat finder process, the footstep motion artifacts during running were effectively removed from the sensor signal (Channel A of Fig. 13) such that the output signal (Channel C of

Fig. 13) contained blood flow information with minimal motion artifacts. Thus, this output signal contained blood flow pulse signals that could then be "counted" by the beat finder to generate an accurate heart rate assessment.

5 In the specific analysis results 400 of Fig. 15, a beat finder was employed, following the adaptive filter process 200 of Fig. 13, to count heart beats. A more general method 500 for extracting physiological information from sensor signals in the midst of noise is illustrated in Fig. 16. The first block (block 510) represents the pre-adaptive signal conditioning stage. This process may utilize a combination of filters to remove frequency bands outside the range of  
10 interest. For example, a combination of band-pass, low-pass, and/or high-pass filters (such as digital filters) may be used. The second block (block 520) represents an adaptive filtering process such as the process 200 described in Fig. 13. This process may utilize the pre-conditioned signals from block 510 as inputs into an adaptive filter that reduces motion or environmental artifacts and  
15 noise in the primary data channel. The third block (block 530) represents the parameter extraction stage. This process may utilize a combination of signal conditioning filters in addition to peak finding (such as beat finding) algorithms to calculate properties of interest (e.g. heart rate, blood flow, heart rate variability, respiration rate, blood gas/analyte level, and the like). The method 500 of Fig. 16  
20 may be encoded in the firmware of a microprocessor (or similar electronics) to facilitate real-time processing of physiological information.

Fig. 17 is a block diagram that illustrates sensor signals being processed into a digital data string including activity data and physiological data using the method 500 of Fig. 16, according to some embodiments of the present  
25 invention. Optical detectors 26 and optical emitters 24 may include digitizing circuitry such that they may be connected serially to a digital bus 600. Data from the detectors 26 may be processed by a processor/multiplexer 602 to generate multiple data outputs 604 in a serial format at the output 606 of the processor  
30 602. In some embodiments, the processing methods may involve one or more of the methods described in Figs. 13, 14A-14D, 15 and 16. The multiple data outputs 604 may be generated by the processor/multiplexer 602 by time division multiplexing or the like. The processor 602 may execute one or more serial processing methods, wherein the outputs of a plurality of processing steps may provide information that is fed into the multiplexed data outputs 604.

The multiplexed data outputs 604 may be a serial data string of activity and physiological information 700 (Fig. 18) parsed out specifically such that an application-specific interface (API) can utilize the data as required for a particular application. The applications may use this data to generate high-level assessments, such as overall fitness or overall health. Furthermore, the individual data elements of the data string can be used to facilitate better assessments of other individual data elements of the data string. As a specific example, the Blood Flow data string may contain information on the first and second derivatives of each blood pulse. This information may be processed from a PPG signal by running the adaptively filtered heart rate signal through a slope-finder algorithm (such as a differentiator circuit). In another example, the filtered PPG signal may be run through an integration circuit to estimate blood volume over each blood pulse. This information may then be used to assess blood pressure and blood oxygen levels more accurately than a direct measurement of blood pressure or blood oxygen levels.

In some embodiments of the invention, new methods of generating physiological assessment algorithms are enabled. These new methods may be achieved by measuring each data output of the data output string 604 in real time while an earbud user is also wearing one or more benchmark sensors. Principal component analysis, multiple linear regression, or other statistical or machine learning techniques can then be used to generate statistical relationships between the data outputs 604 and high level assessments measured simultaneously by the benchmark sensors. These benchmark sensors may measure aerobic fitness level,  $VO_2max$ , blood pressure, blood analyte levels, and the like. The relationships between the earbud sensor and benchmark sensor readings may be translated as algorithms embedded in the earbud, wherein each algorithm generates at least one assessment for the earbud user. In some cases, Bland-Altman plots of the earbud-derived assessment value versus the benchmark value may be used to judge the effectiveness of the algorithm, and this information may then feedback into improving the said earbud-derived assessment algorithm. Examples of these assessments may include aerobic fitness level,  $VO_2max$ , blood pressure, blood analyte levels (such as blood glucose, oxygen, carbon monoxide, etc.), and the like.

In some cases, it may be important to remove the effects of ambient optical noise from the physiological signal of a light-guiding earbud 30. In such cases, one or more optical detectors 26 may be configured to measure outdoor or ambient lighting, and this information may be fed back into the processor 602 (Fig. 17) to extract external optical noise from the physiological signal. For example, some optical detectors may be configured to measure light from the ear, whereas others may be configured to measure light from the ambient environment, such as sunlight, room light, headlights, or the like. This may be achieved by directing the optical detectors towards and away from the ear, respectively. In a specific example, the ambient light reaching the optical detectors 26 may generate an undesirable sinusoidal response on an optical detector that is configured to measure light from the ear. This undesirable sinusoidal noise response may be generated as an earbud user moves their head from side to side while running. Thus, Channel A of the adaptive filter 200 (Fig. 13) may include physiological information plus undesired ambient optical noise information. To remove this noise from the final output Channel C, the output of the optical detector configured to measure ambient optical noise may be an input (Channel B of Fig. 13) into the adaptive filter 200. In this way, ambient noise from Channel A may be removed to generate a mostly physiological signal in Channel C.

The optical detectors 26 and emitters 24 may be of multiple wavelengths, with the goal of providing specialized physiological information for each wavelength. Referring to Fig. 19, for example, violet or UV light may be used to measure motion-related aspects of the ear, as violet and UV light may not penetrate greatly through the skin of the ear. Green, red, and IR wavelengths may have deeper penetration and provide information on the blood vessels and blood analyte levels. Blue wavelengths may be particularly useful for gauging changes in the size of the blood vessels.

Embodiments of the present invention may be more generally applied to non-optical or mix-optical configurations. For example, one or more of the detectors 26 and emitters 24 may be mechanical, acoustical, electrical, gravimetric, or nuclear detectors and emitters, all providing physiological information to the processor 602 (Fig. 17). For example, an accelerometer or capacitor may be used as a detector 26 for the noise reference (Channel B)

input of an adaptive filter running in real-time on the processor 602.

Referring to Fig. 20, a chipset 800 for use in light-guiding earbuds 30, according to some embodiments of the present invention, may include optical emitters, optical detectors, mechanical, acoustical, electrical, gravimetric, nuclear detectors, additional sensors, signal processing, power regulation, digital control, and input/output lines. The chipset 800 may include firmware for signal extraction and for generating physiological assessments from information derived from the sensors and noise sources. One benefit of the chipset configuration is that the chipset 800 may be fully or partially integrated and hence compact and scalable to a wide range of products. To be integrated with a light-guiding earbud 30, the chipset 800 may be aligned such that the sensor region has an exposed window to a subject's ear. For example, the chipset 800 may be attached to the earbud base 50 or an earbud sensor module 70 and aligned line-of-sight through an acoustic orifice of an earbud and/or through a transparent end portion of an earbud 30 (e.g., through end portion 18f of the earbud 30 of Figs. 8A-8B or 18w of Figs. 4 & 5).

A specific embodiment of a chipset 800 for a stereo headset, according to some embodiments of the present invention, is illustrated in Fig. 21. This stereo chipset 800 may be integrated into an electronic module that may be attached to a printed circuit board. In another configuration, this stereo chipset 800 may be integrated into 3 modules, wherein the right and left earbud sensors comprise two separate modules, embedded in right and left earbuds respectively, and wherein the remaining circuit elements comprise the main module.

According to other embodiments of the present invention, monitoring devices with light-guiding regions may be configured to be attached to earlobes, fingers, toes, other digits, etc. For example, Figs. 22A-22B illustrate a monitoring device 70 that is configured to fit over a finger F, for example, as a finger ring, according to some embodiments of the present invention. The illustrated monitoring device 70 includes a generally circular band capable of encircling a finger F of a subject, with a cylindrical outer body portion 72 and a generally cylindrical inner body portion 74 secured together in concentric relationship. The outer body portion may be formed from virtually any type of material and may have an ornamental configuration. In some embodiments, the

outer body portion 72 may include a flex circuit containing various electronic components, such as a microprocessor, D/A converter, power source, power regulator, and the like. However, in some embodiments, the outer body portion 72 may not be required and the circular band of the monitoring device 70 includes only the inner body portion 74 secured to the base 50 (described below).

A base 50 is secured to the inner and outer body portions 74, 72 of the illustrated embodiment and may be similar to the base 50 described above with respect to Figs. 3, 4A-4D, 5, 6, 7A-7B, 8A-8D, 9A-9B, and 11A-11B. The base 50 provides support for one or more sensors. In the illustrated embodiment, the base 50 supports an optical emitter 24, an optical detector 26, and an optical noise detector 26'.

The inner body portion 74 includes light transmissive material similar to that of the cover 18 described above with respect to Figs. 3, 4A-4D, 5, 6, 7A-7B, 8A-8D, 9A-9B, and 11A-11B. In some embodiments, the inner body portion 74 is formed from a soft, resilient material, such as silicone, which deforms when a finger of a subject is inserted therethrough. However, various types of light transmissive materials may be utilized, without limitation.

A layer of cladding material 21 is applied to (or near) the outer surface 74a of the inner body portion 74 and a layer of cladding material 21 is applied to (or near) the inner surface 74b of the inner body portion 74, as illustrated, to define a light-guiding region 19. As such, the inner body portion 74 serves as a light guide that delivers light from the optical emitter 24 to the finger F of a subject at one or more predetermined locations and that collects light from the finger F and delivers the collected light to the optical detectors 26, 26'. In some embodiments, the cladding material 21 may be embedded within the inner body portion 74 adjacent to the outer surface 74a and inner surface 74b. In some embodiments, the outer body portion 72 may serve as a cladding layer adjacent to the inner body portion outer surface 74a.

In the illustrated embodiment, windows 74w are formed in the cladding material 21 and serve as light-guiding interfaces to the finger F. There may be any number of these windows, as may be required for sufficient optical coupling, and the windows 74w may include lenses such as those described above (e.g., lens 18L illustrated in Fig. 6), to focus light emitted by the optical



emitter 24 onto one or more portions of a finger F and/or to focus collected light on the light detectors 26, 26'. Similarly, the windows 74w may include optical filters to selectively pass one or more optical wavelengths and reflect and/or absorb other optical wavelengths.

5           In the illustrated embodiment, the light-guiding region 19 includes light blocking members 80 that isolate light emitter 24 and light detector 26 from each other. In some embodiments, only a single light blocking member 80 may be utilized. For example, a single light blocking member 80 may be positioned between the light emitter 24 and light detector 26. By adding an additional  
10 blocking member 80, as illustrated, the only light reaching the optical detector 26 may be light passing through at least one portion of the finger.

          In some embodiments, multiple light emitters 24 may be utilized. For example, light emitters of different wavelengths may be utilized. In some embodiments, multiple light detectors may be utilized that are configured to  
15 measure light at different wavelengths (e.g., light detectors 26 and 26' may be configured to measure light at different wavelengths). In this way, either optical detector may be configured to measure light mostly due to motion (such as finger motion) or to measure light mostly due to physiological processes and motion. For example, if the windows 74w incorporate IR-pass filters, visible light  
20 will not pass through the windows 74w and the light will be scattered to the photodetectors 26 and 26'. Or, if the two illustrated blocking regions 80 are in place, and if photodetector 26' is configured to measure only visible light and photodetector 26 is configured to measure only IR light, then only the photodetector 26' will detect scattered visible light. As this visible scattered light  
25 cannot reach the finger, the scatter intensity measured by optical detector 26' may be indicative of motion and not physiological activity.

          Referring now to Fig. 23, a monitoring device 70', according to some embodiments of the present invention, may be configured to be attached to a body of a subject as a bandage or "band-aid". The illustrated monitoring  
30 device 70' includes an outer layer or body portion 72 and an inner layer or body portion 74 secured together, as illustrated. The outer body portion may be formed from virtually any type of material and may have an ornamental configuration. In some embodiments, the outer body portion 72 may include a flex circuit containing various electronic components, such as a microprocessor,

D/A converter, power source, power regulator, and the like. However, in some embodiments, the outer body portion 72 may not be required and the monitoring device 70' includes only the inner body portion 74 secured to the base 50 (described below).

5           A base 50 is secured to the inner and outer body portions 74, 72 and may be similar to the base 50 described above with respect to Figs. 3, 4A-4D, 5, 6, 7A-7B, 8A-8D, 9A-9B, and 11A-11B. The base 50 provides support for one or more sensors. In the illustrated embodiment, the base 50 supports an optical emitter 24, an optical detector 26, and an optical noise detector 26'.

10           The inner body portion 74 is formed of light transmissive material similar to that of the cover 18 described above with respect to Figs. 3, 4A-4D, 5, 6, 7A-7B, 8A-8D, 9A-9B, and 11A-11B. In some embodiments, the inner body portion 74 is formed from a soft, resilient material, such as silicone, which deforms when the device is attached to the body of a subject. However, various  
15 types of light transmissive materials may be utilized, without limitation.

          A layer of cladding material 21 is applied to (or near) the outer surface 74a of the inner body portion 74 and a layer of cladding material 21 is applied to (or near) the inner surface 74b of the inner body portion 74, as  
20 illustrated, to define a light-guiding region 19. As such, the inner body portion 74 serves as a light guide that delivers light from the optical emitter 24 to the body of a subject at one or more predetermined locations and that collects light from the body and delivers the collected light to the optical detectors 26, 26'. In some  
25 embodiments, the cladding material 21 may be embedded within the inner body portion 74 adjacent to the outer surface 74a and inner surface 74b. In some  
embodiments, the outer body portion 72 may serve as a cladding layer adjacent to the inner body portion outer surface 74a.

          In the illustrated embodiment, windows 74w are formed in the cladding material 21 and serve as light-guiding interfaces to the body of a subject. There may be any number of these windows, as may be required for  
30 sufficient optical coupling, and the windows 74w may include lenses such as those described above (e.g., lens 18L illustrated in Fig. 6), to focus light emitted by the optical emitter 24 onto one or more portions of the body of a subject and/or to focus collected light on the light detectors 26, 26'. Similarly, the windows 74w may include optical filters to selectively pass one or more optical

wavelengths and reflect and/or absorb other optical wavelengths.

In the illustrated embodiment, the light-guiding region 19 includes a light blocking member 80 that isolates light emitter 24 and light detector 26 from each other. In some embodiments, multiple light emitters 24 may be utilized. For  
5 example, light emitters of different wavelengths may be utilized. In some embodiments, multiple light detectors may be utilized that are configured to measure light at different wavelengths (e.g., light detectors 26 and 26' may be configured to measure light at different wavelengths).

The illustrated monitoring device 70' may be removably attached to  
10 the body of a subject via adhesive on one or more portions of the device 70'. In some embodiments, adhesive may be on the inner body portion 74. In some embodiments where the outer body portion is utilized, the adhesive may be on the outer body portion 74. In some embodiments, the illustrated device 70' may be removably attached to the body of a subject via tape or other known devices.

15 The foregoing is illustrative of the present invention and is not to be construed as limiting thereof. Although a few exemplary embodiments of this invention have been described, those skilled in the art will readily appreciate that many modifications are possible in the exemplary embodiments without materially departing from the teachings and advantages of this invention.  
20 Accordingly, all such modifications are intended to be included within the scope of this invention as defined in the claims. The invention is defined by the following claims, with equivalents of the claims to be included therein.

THAT WHICH IS CLAIMED IS:

1. A monitoring device configured to be attached to the body of a subject, comprising:

5 an outer layer and an inner layer secured together, the inner layer comprising light transmissive material, and having inner and outer surfaces;  
a base secured to at least one of the outer and inner layers and comprising at least one optical emitter and at least one optical detector;  
a layer of cladding material near the outer surface of the inner  
10 layer; and  
at least one window formed in the layer of cladding material that serves as a light-guiding interface to the body of the subject, wherein the light transmissive material is in optical communication with the at least one optical emitter and the at least one optical detector, wherein the light transmissive  
15 material is configured to deliver light from the at least one optical emitter to the body of the subject along a first direction and to collect light from the body of the subject and deliver the collected light in a second direction to the at least one optical detector, wherein the first and second directions are substantially parallel.

20 2. The monitoring device of Claim 1, wherein the at least one window is oriented substantially parallel with a light emitting surface of the at least one optical emitter.

25 3. The monitoring device of Claim 1, wherein the at least one window is oriented substantially parallel with a light detecting surface of the at least one optical detector.

30 4. The monitoring device of Claim 1, wherein the outer layer and/or inner layer comprises adhesive in one or more locations that is configured to adhesively secure the device to the body of the subject.

5. The monitoring device of Claim 1, wherein the light transmissive material comprises a lens region in optical communication with the at least one optical emitter that focuses light emitted by the at least one optical

emitter.

6. The monitoring device of Claim 1, further comprising a light reflective material on at least a portion of one or both of the inner and outer  
5 surfaces of the inner layer, wherein the at least one optical detector comprises first and second optical detectors, and further comprising a signal processor, and wherein at least a portion of light reflected by the light reflective material and detected by the second optical detector is processed by the signal processor as a motion noise reference for attenuating motion noise from signals produced by  
10 the first optical detector.

7. The monitoring device of Claim 1, wherein the monitoring device further comprises at least one optical filter configured to selectively pass  
15 at least one optical wavelength for transmission into the body of the subject, wherein the at least one optical detector comprises first and second optical detectors, and further comprising a signal processor, and wherein at least a portion of light not passed by the optical filter and detected by the second optical detector is processed by the signal processor as a motion noise reference for attenuating motion noise from signals produced by the first optical detector.  
20

8. The monitoring device of Claim 1, wherein the base comprises a signal processor configured to receive and process signals produced by the at least one optical detector.

9. The monitoring device of Claim 1, wherein the base  
25 comprises a transmitter configured to transmit signals processed by the signal processor to a remote device.

10. The monitoring device of Claim 1, wherein the at least one  
30 window comprises at least two windows, and further comprising light blocking material positioned between the at least one optical emitter and the at least one optical detector such that the at least one optical emitter and the at least one optical detector are not in direct optical communication with each other.

11. A monitoring device configured to be attached to the body of a subject, comprising:

a first layer comprising light transmissive material, the first layer having inner and outer surfaces;

5 a base secured to the first layer and comprising at least one optical emitter and at least one optical detector;

a layer of cladding material near the inner and outer surfaces of the first layer; and

10 at least one window formed in the layer of cladding material that serves as a light-guiding interface to the body of the subject, wherein the light transmissive material is in optical communication with the at least one optical emitter and the at least one optical detector, and is configured to deliver light from the at least one optical emitter to the body of the subject along a first direction and to collect light from the body of the subject and deliver the collected  
15 light in a second direction to the at least one optical detector, wherein the first and second directions are substantially parallel.

12. The monitoring device of Claim 11, wherein the at least one window is oriented substantially parallel with a light emitting surface of the at  
20 least one optical emitter.

13. The monitoring device of Claim 11, wherein the at least one window is oriented substantially parallel with a light detecting surface of the at  
25 least one optical detector.

14. The monitoring device of Claim 11, wherein the first layer comprises adhesive in one or more locations that is configured to adhesively secure the device to the body of the subject.

30 15. The monitoring device of Claim 11, wherein the light transmissive material comprises a lens region in optical communication with the at least one optical emitter that focuses light emitted by the at least one optical emitter.

16. The monitoring device of Claim 11, further comprising a light reflective material on at least a portion of one or both of the inner and outer surfaces of the first layer, wherein the at least one optical detector comprises first and second optical detectors, and further comprising a signal processor, and  
5 wherein at least a portion of light reflected by the light reflective material and detected by the second optical detector is processed by the signal processor as a motion noise reference for attenuating motion noise from signals produced by the first optical detector.

10 17. The monitoring device of Claim 11, wherein the monitoring device further comprises at least one optical filter configured to selectively pass at least one optical wavelength for transmission into the body of the subject, wherein the at least one optical detector comprises first and second optical detectors, and further comprising a signal processor, and wherein at least a  
15 portion of light not passed by the optical filter and detected by the second optical detector is processed by the signal processor as a motion noise reference for attenuating motion noise from signals produced by the first optical detector.

18. The monitoring device of Claim 11, wherein the base  
20 comprises a signal processor configured to receive and process signals produced by the at least one optical detector.

19. The monitoring device of Claim 11, wherein the base  
25 comprises a transmitter configured to transmit signals processed by the signal processor to a remote device.

20. The monitoring device of Claim 11, wherein the at least one window comprises at least two windows, and further comprising light blocking material positioned between the at least one optical emitter and the at least one  
30 optical detector such that the at least one optical emitter and the at least one optical detector are not in direct optical communication with each other.

### ABSTRACT OF THE DISCLOSURE

A monitoring device includes a band capable of encircling a portion of the body of a subject, and an optical emitter and detector attached to the band. The band includes comprises light transmissive material in optical communication with the optical emitter and optical detector and is configured to  
5 deliver light from the optical emitter to one or more locations of the body of the subject and to collect light from one or more locations of the body of the subject and deliver the collected light to the optical detector. The monitoring device may include a signal processor configured to receive and process signals produced by the optical detector, a transmitter configured to transmit signals processed by  
10 the signal processor to a remote device, and/or an optical filter.

1569954



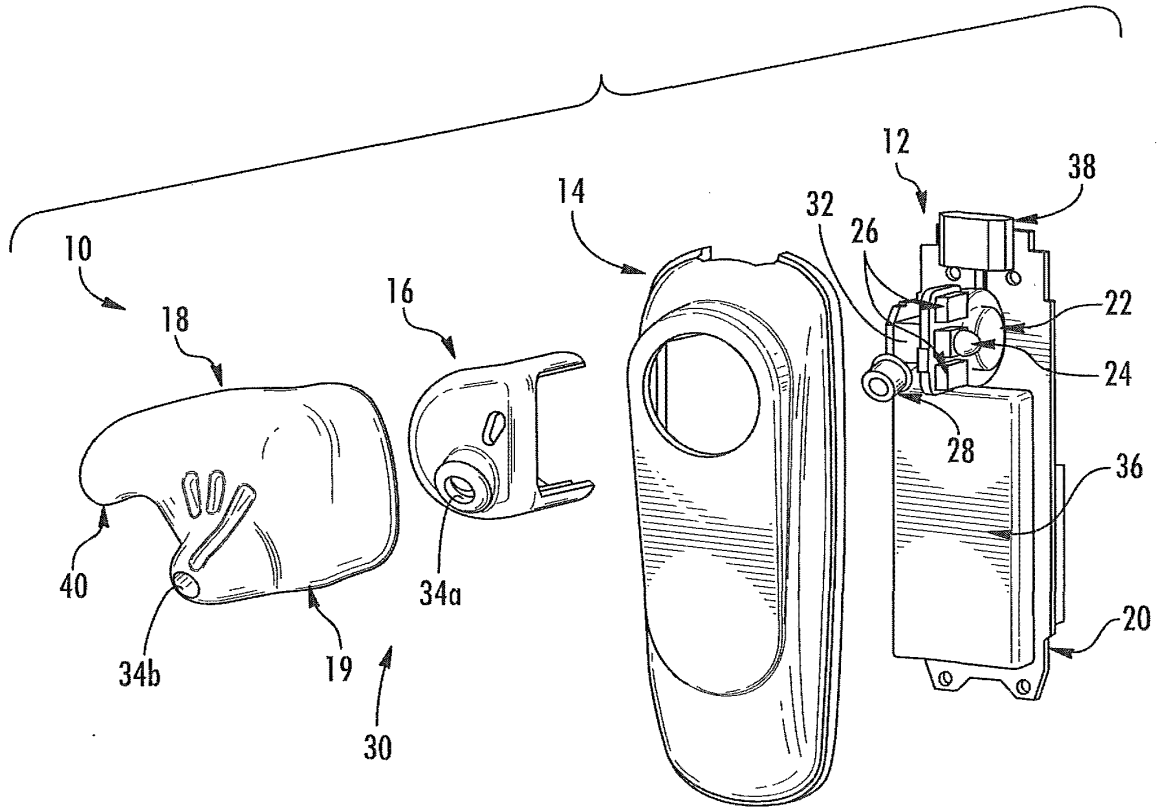

FIG. 1

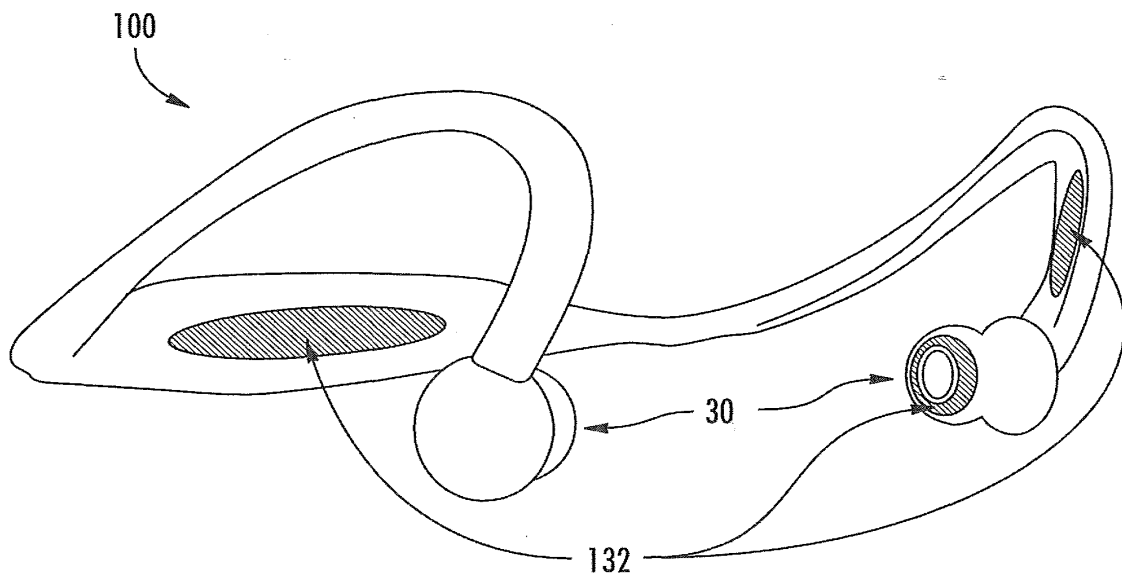

FIG. 2

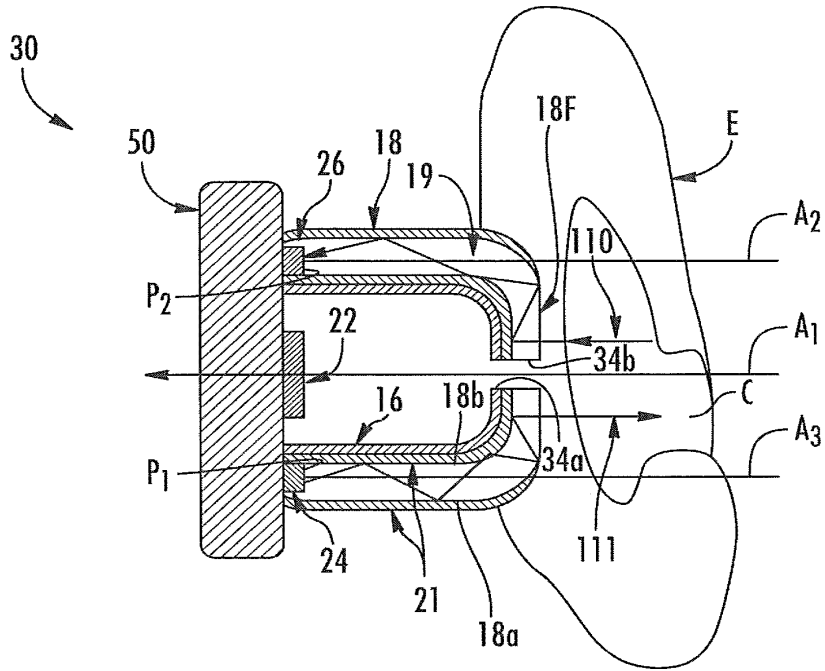

FIG. 3

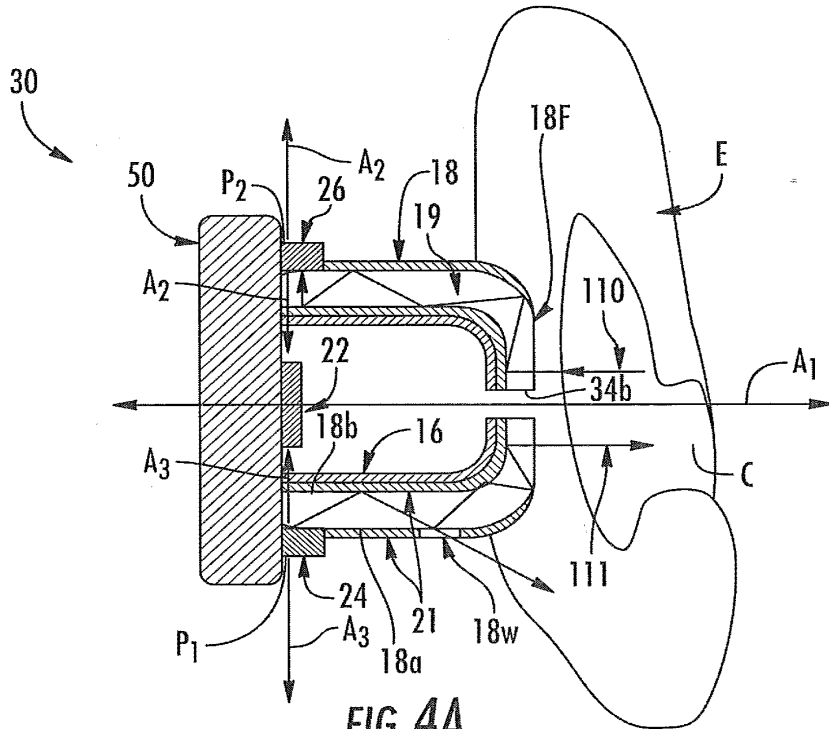

FIG. 4A

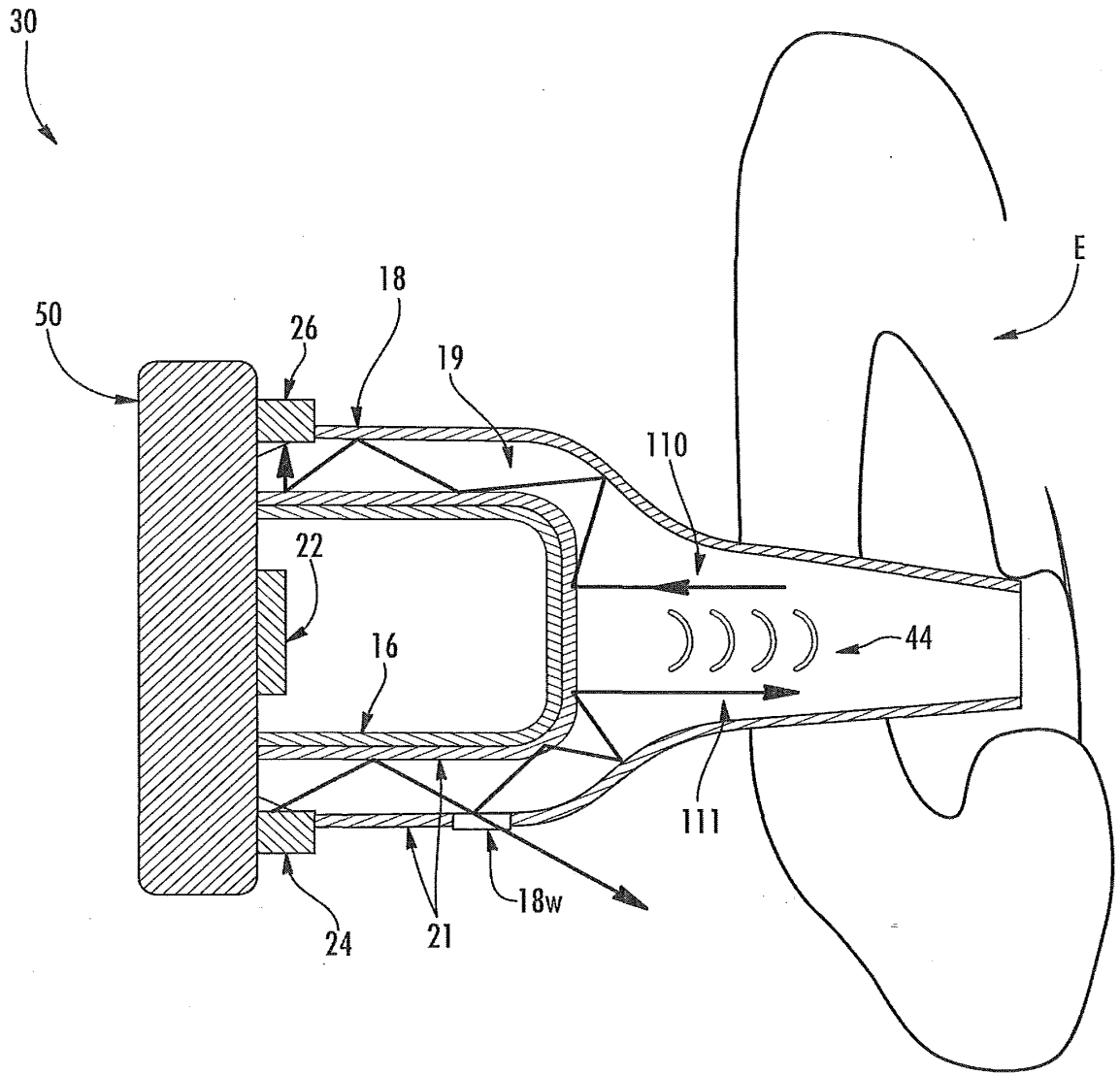
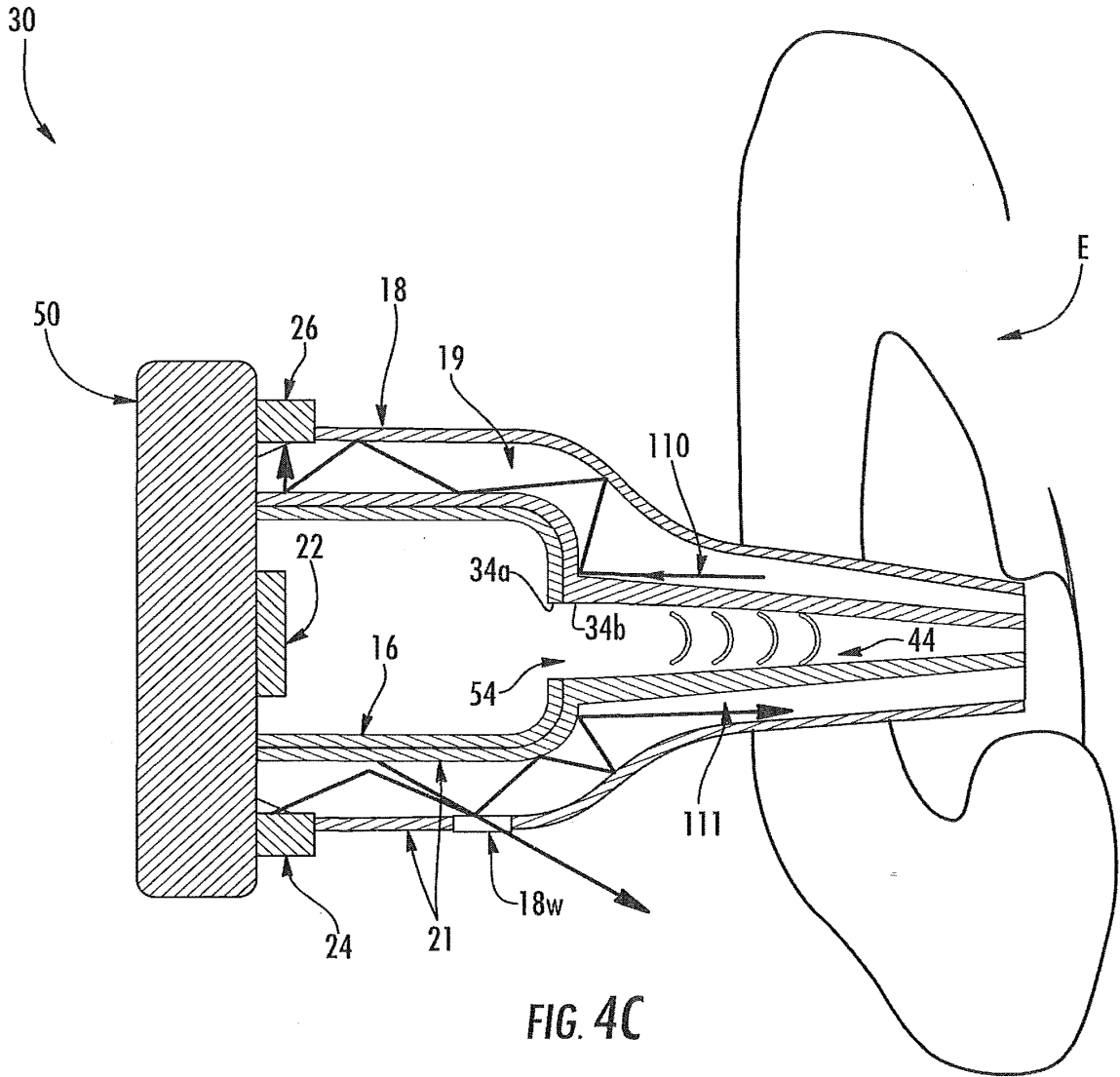

FIG. 4B



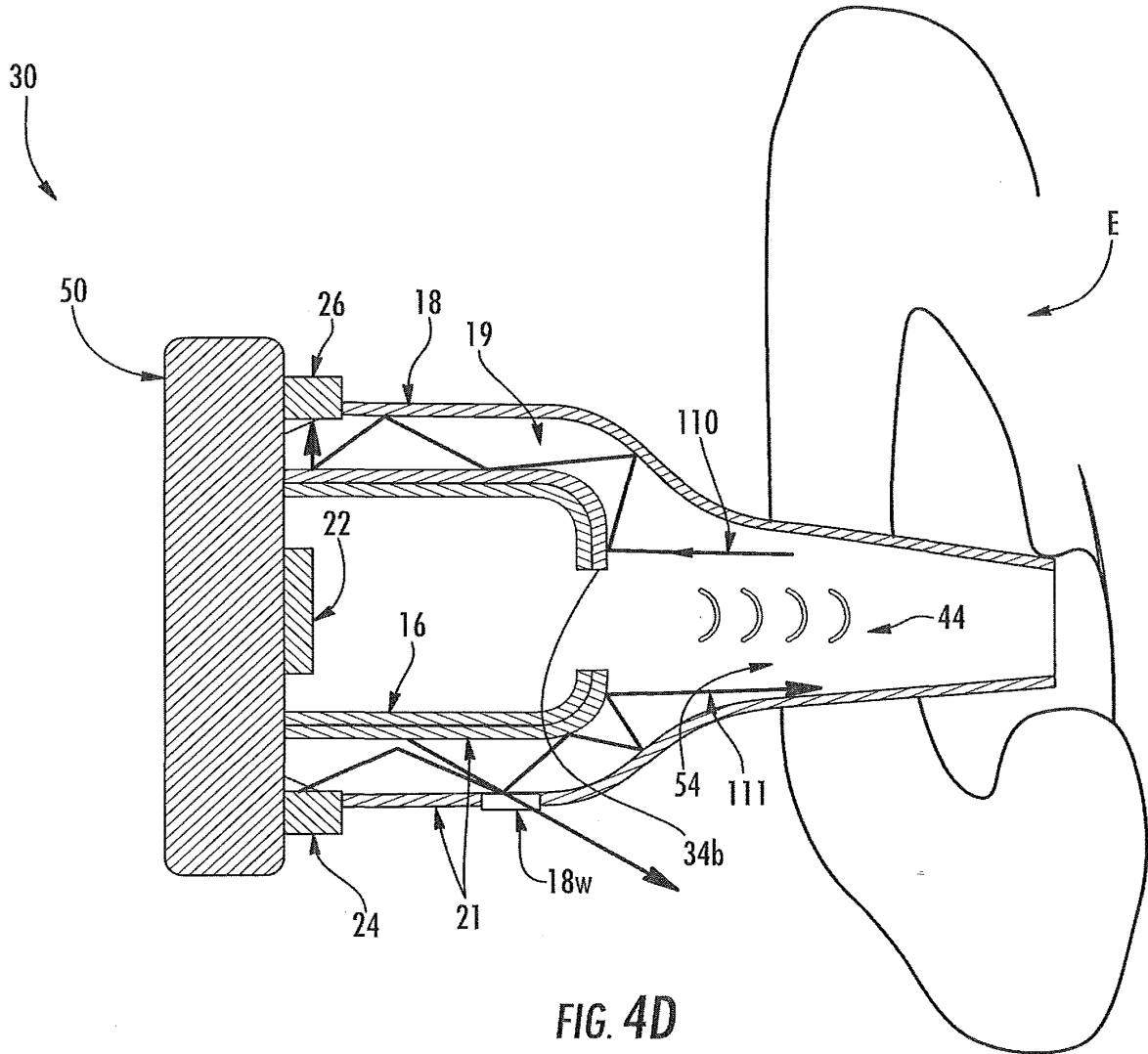

FIG. 4D

6/21

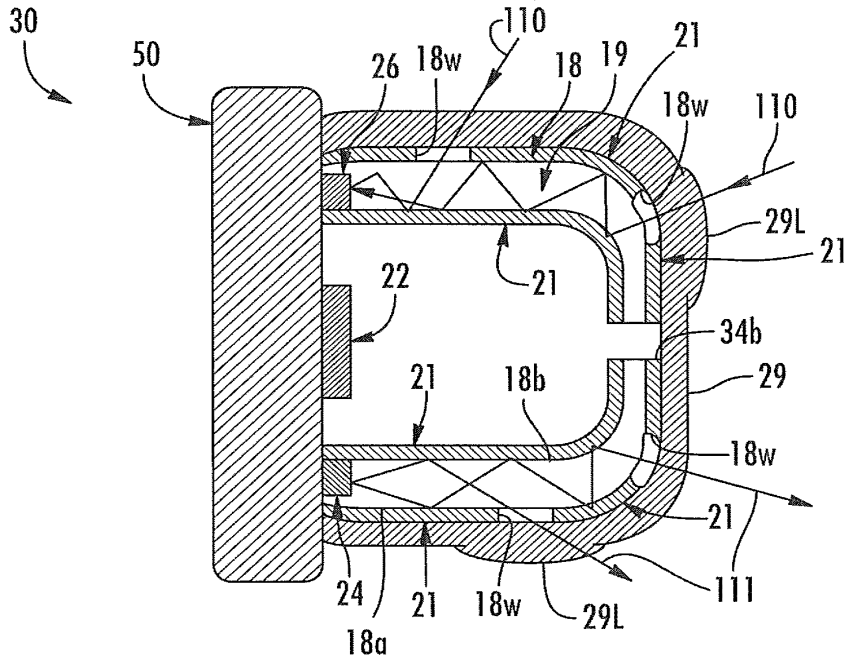

FIG. 5

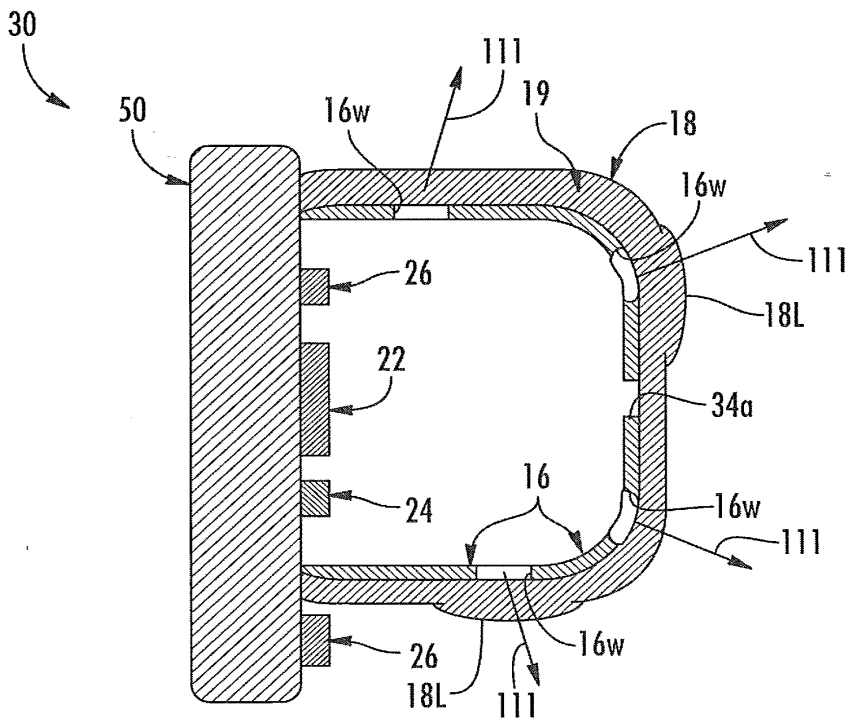

FIG. 6

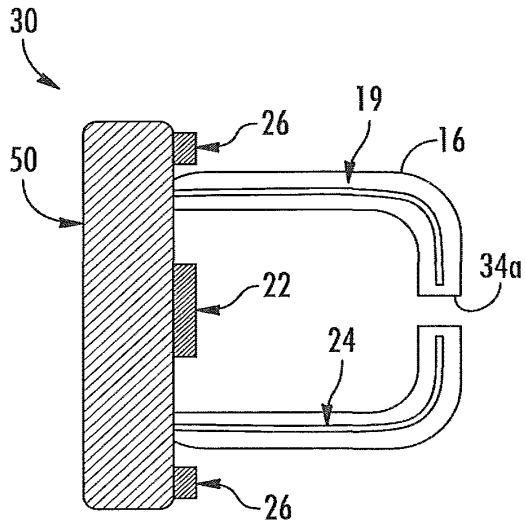

FIG. 7A

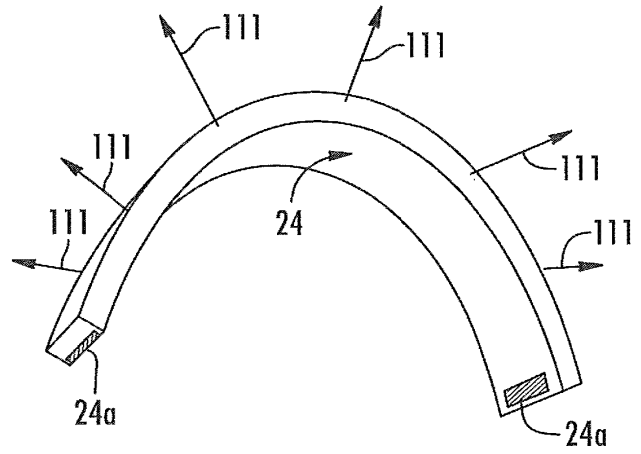

FIG. 7B

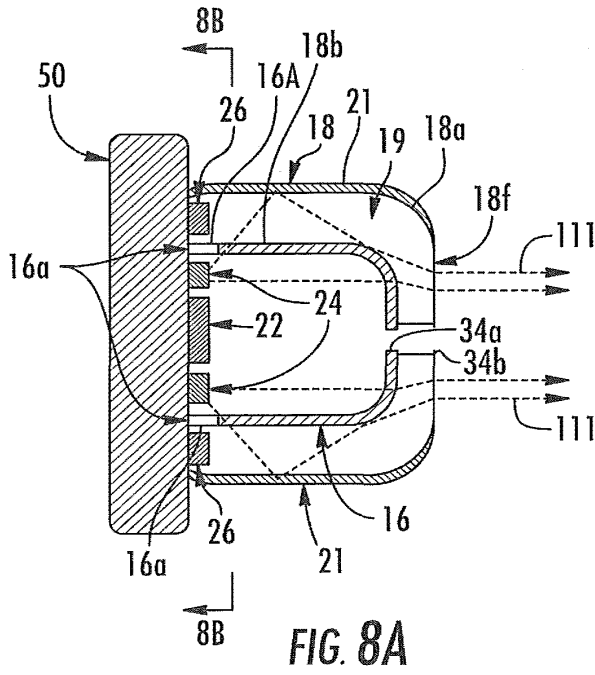

FIG. 8A

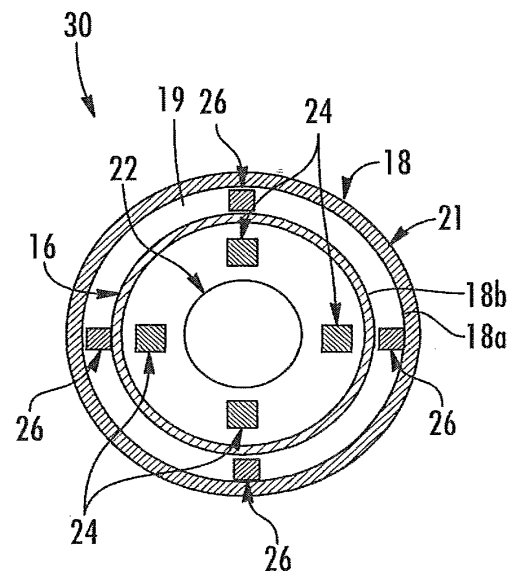

FIG. 8B

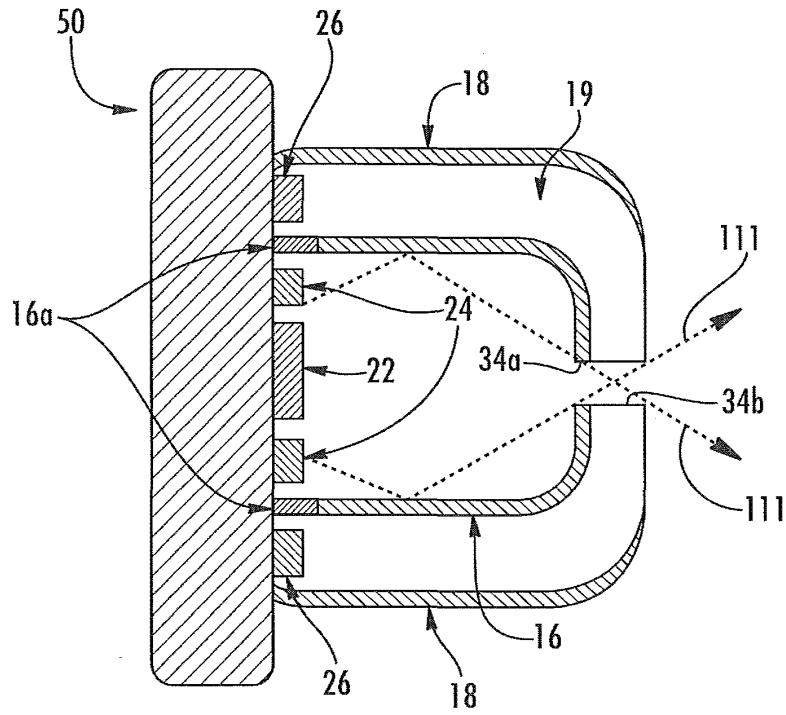

FIG. 8C



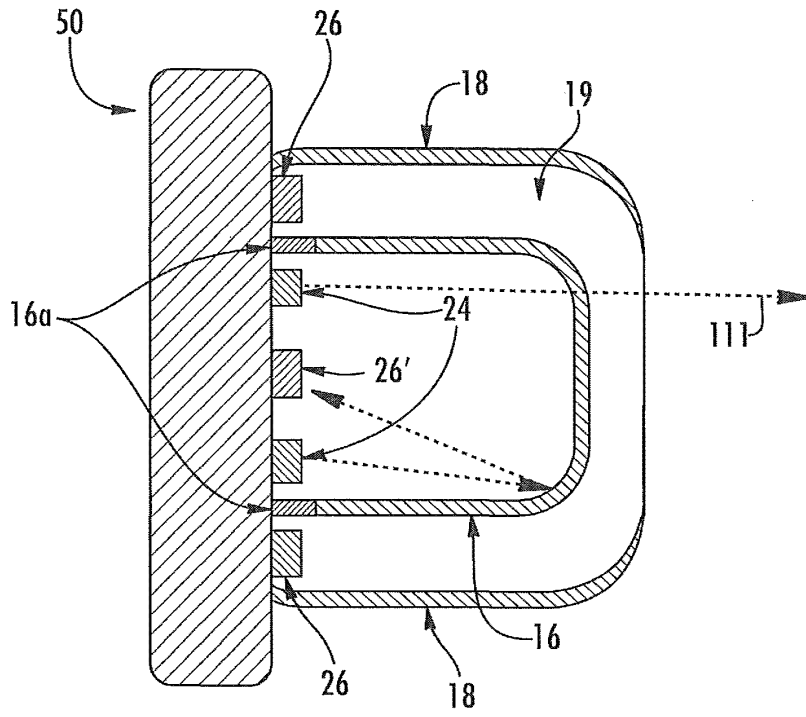

FIG. 8D

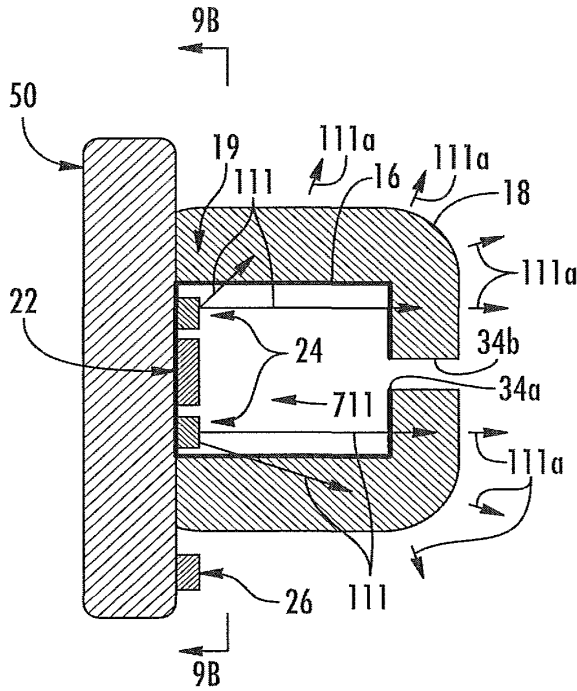

FIG. 9A

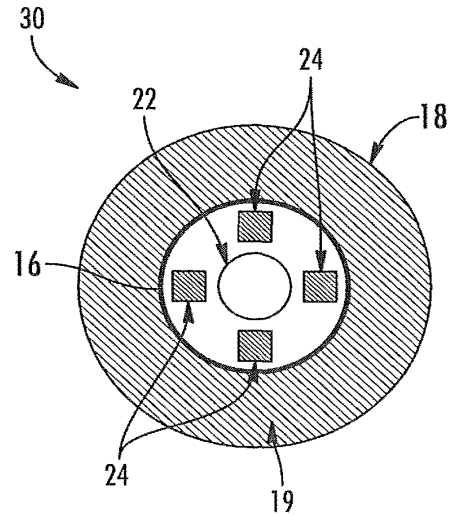

FIG. 9B

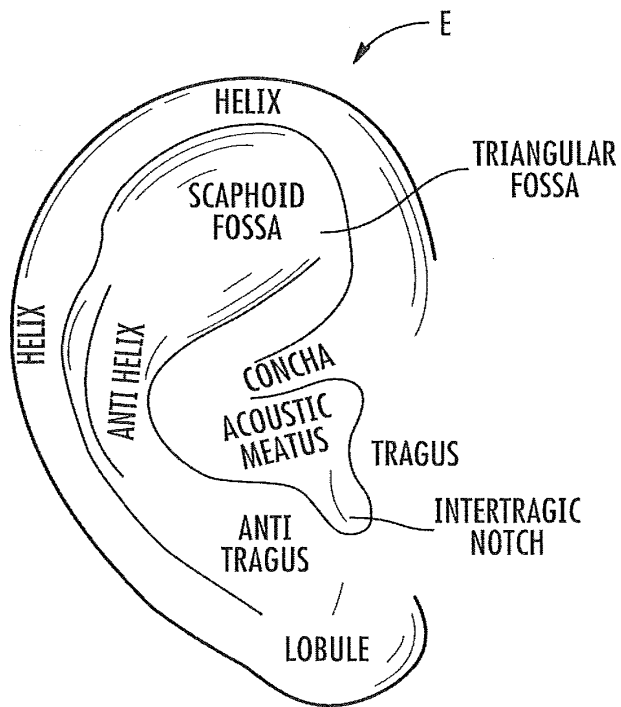

FIG. 10

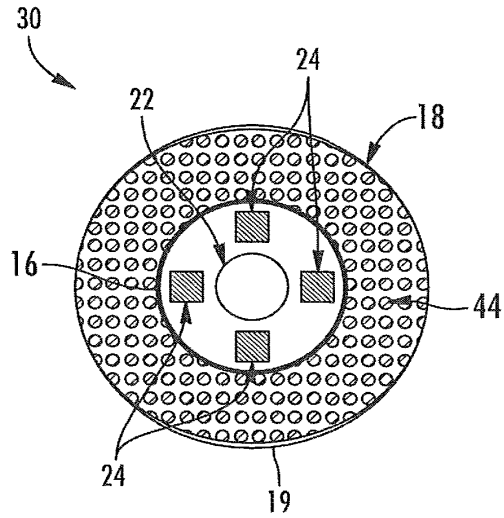

FIG. 9C

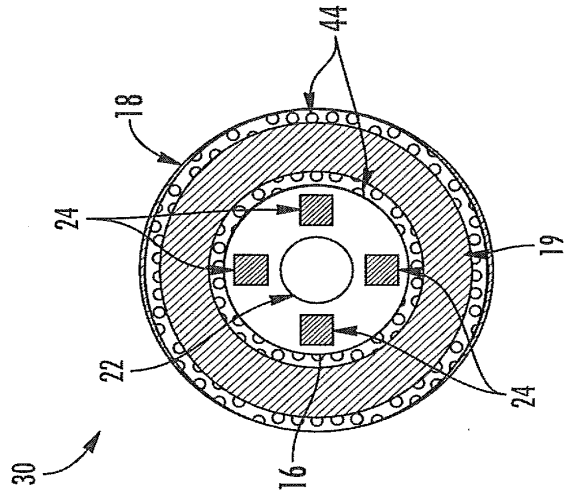

FIG. 9E

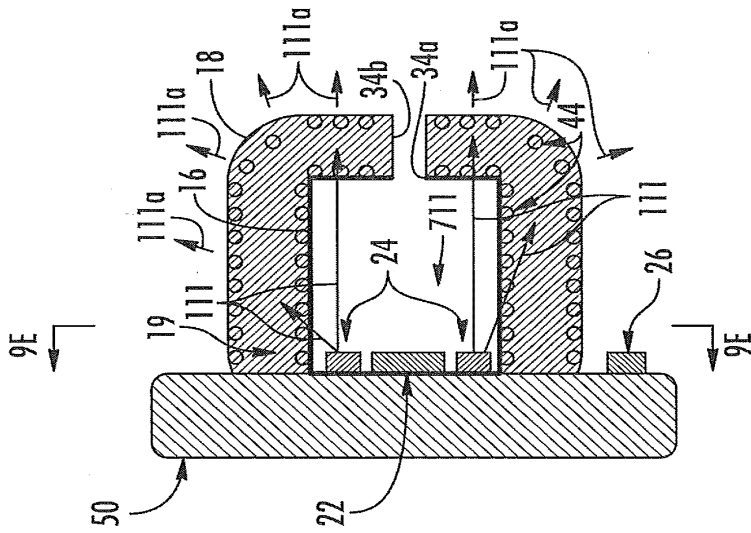

FIG. 9D

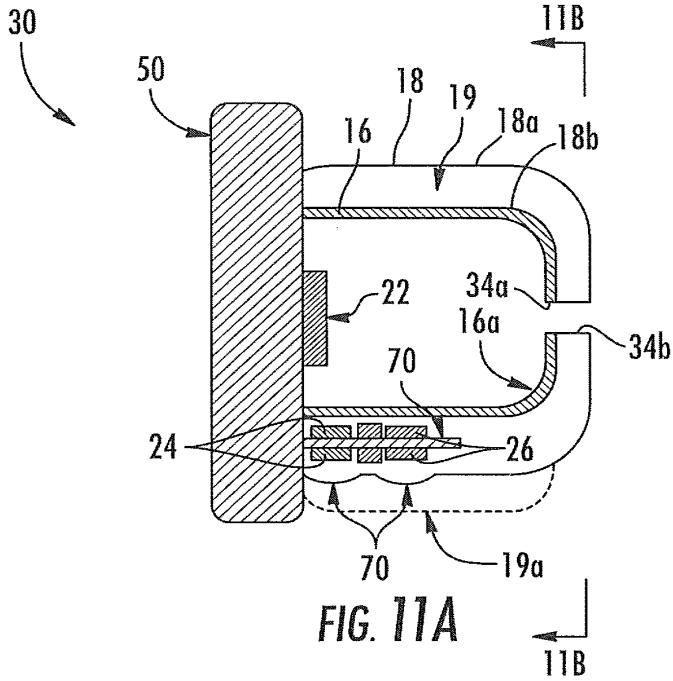

FIG. 11A

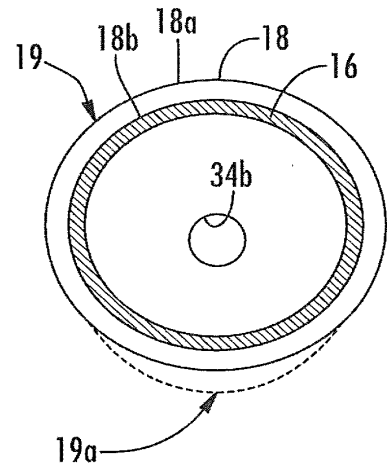
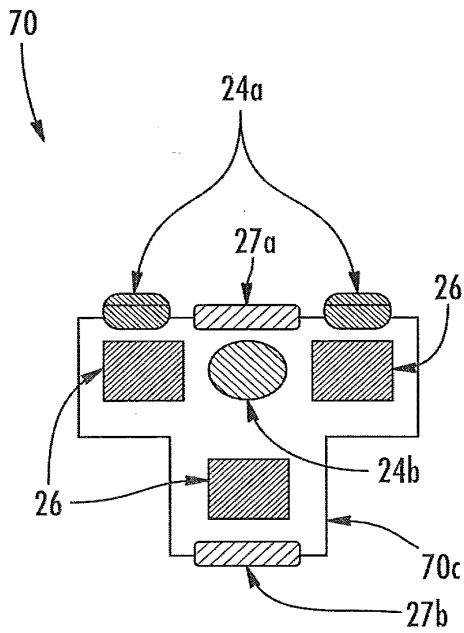
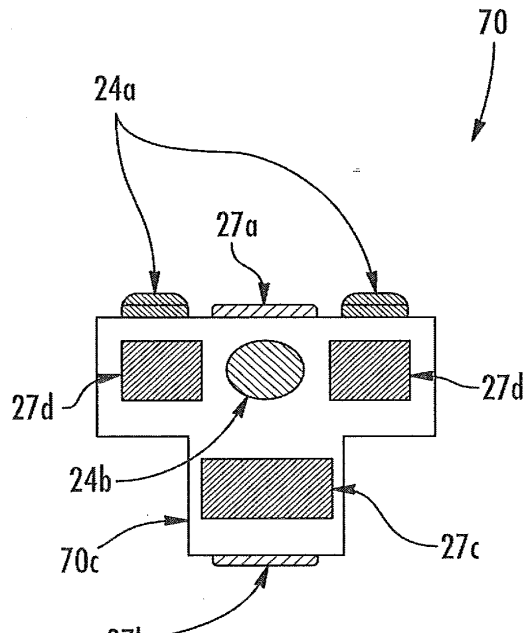

FIG. 11B



FACING ANTITRAGUS  
FIG. 12A



FACING EARBUD  
FIG. 12B

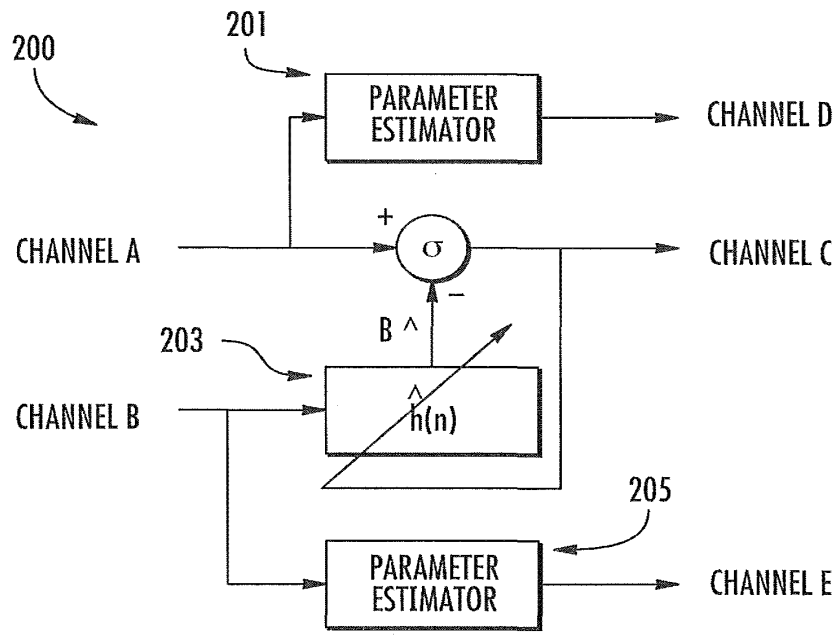

FIG. 13

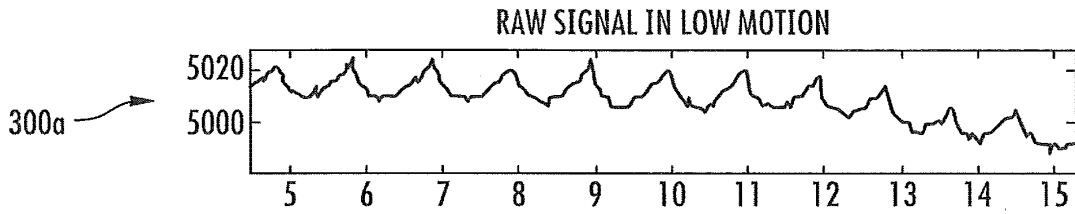

FIG. 14A

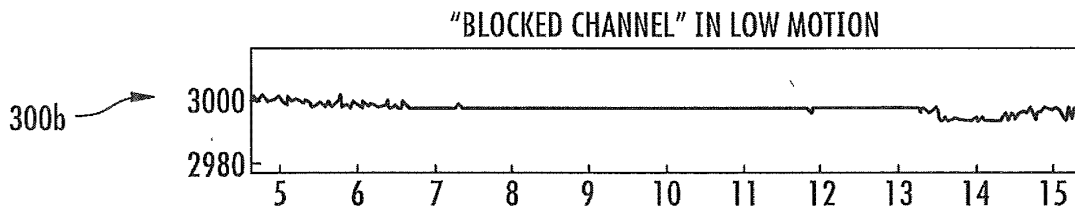

FIG. 14B

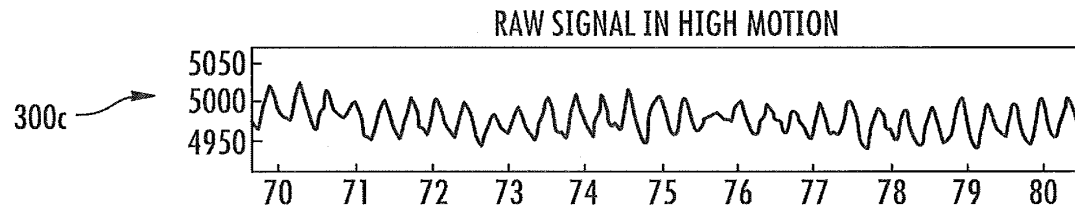

FIG. 14C

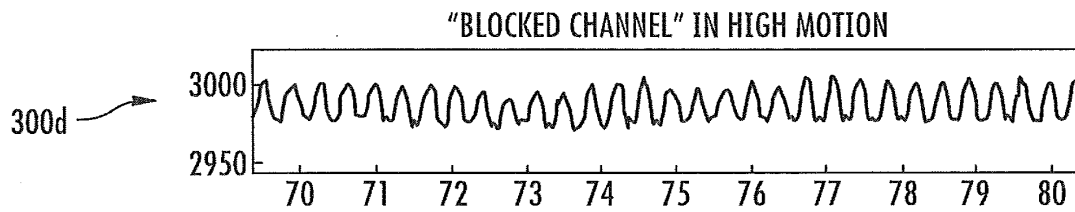

FIG. 14D

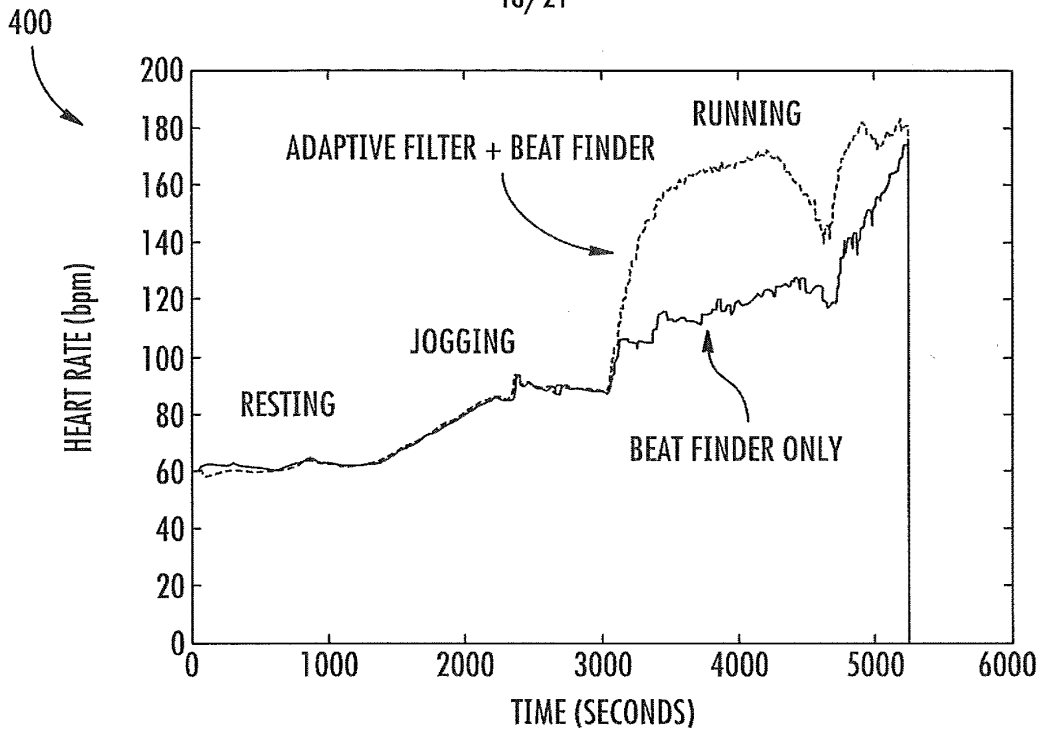

FIG. 15

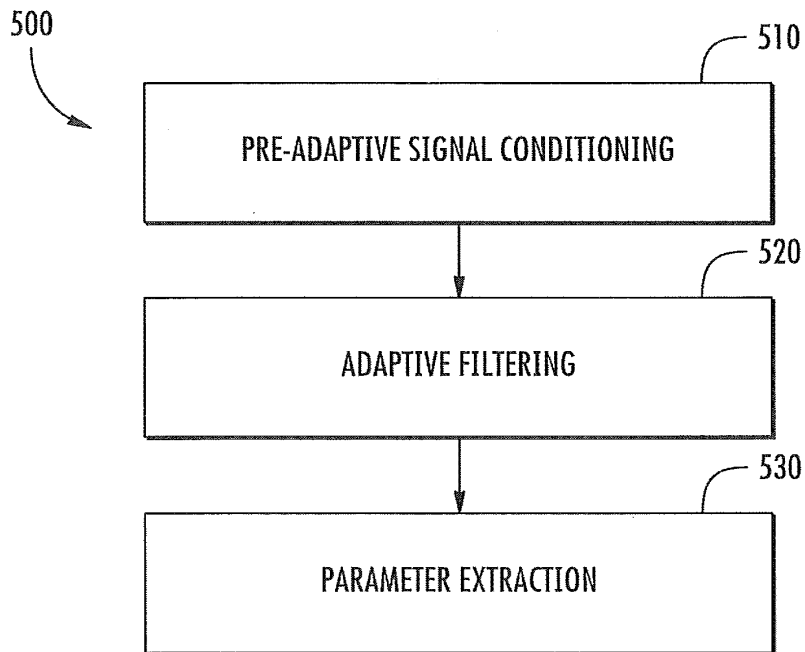

FIG. 16



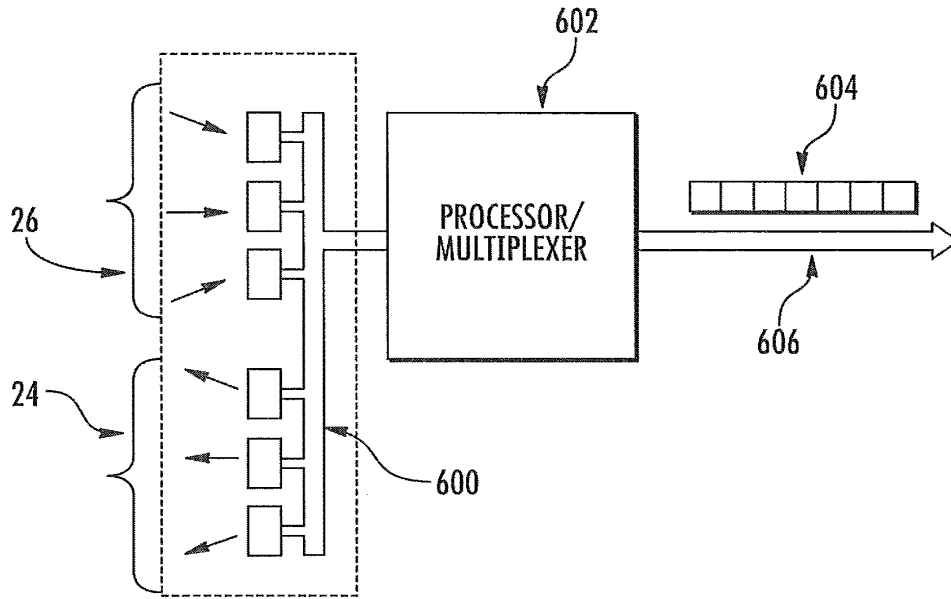

FIG. 17

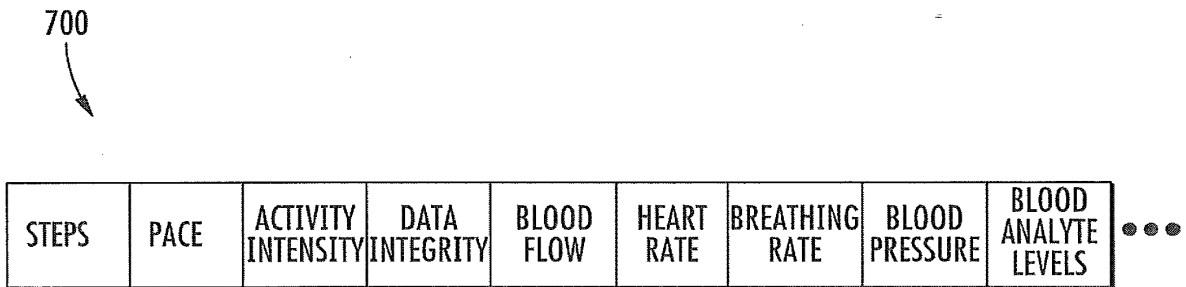

FIG. 18

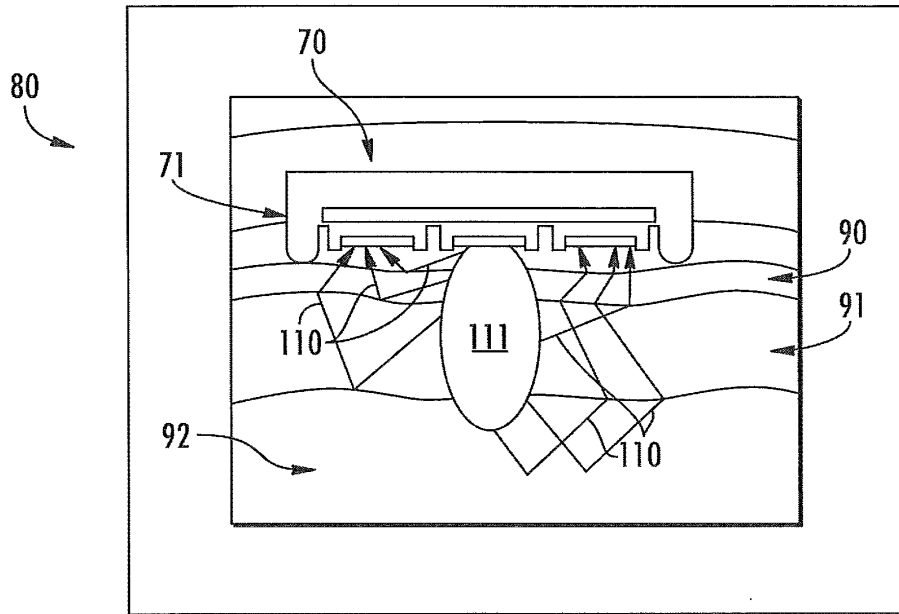

FIG. 19

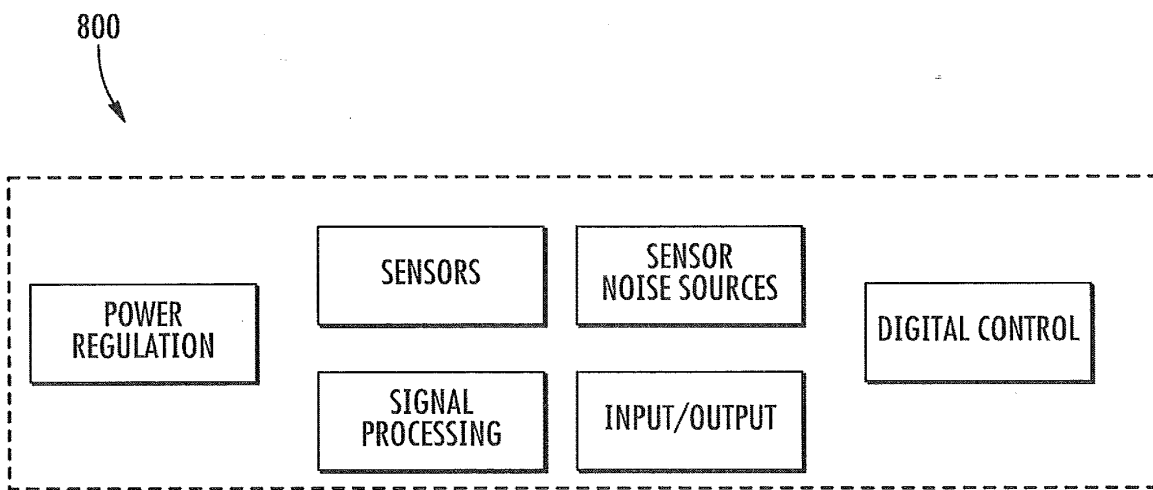

FIG. 20

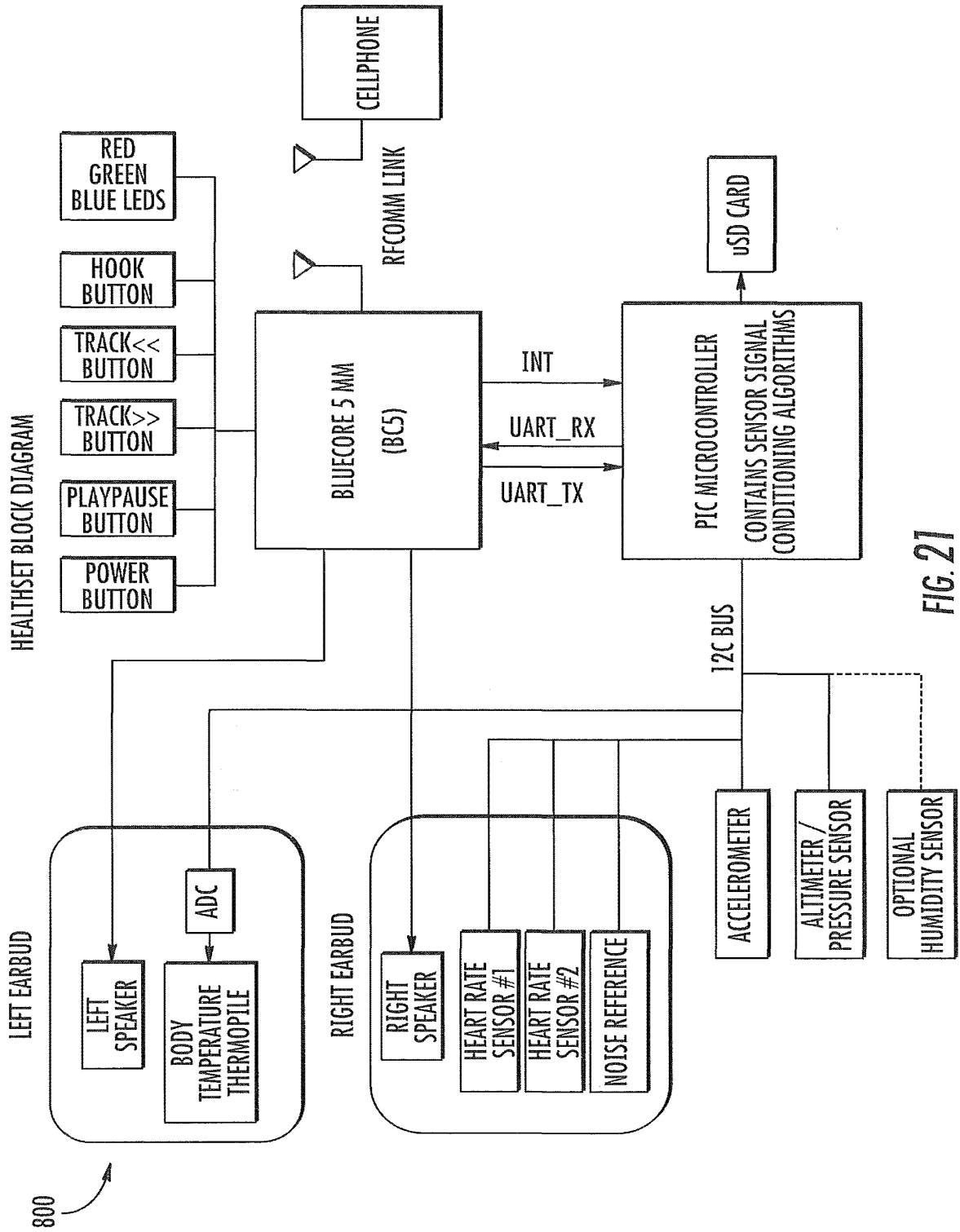

FIG. 21

800

20/21

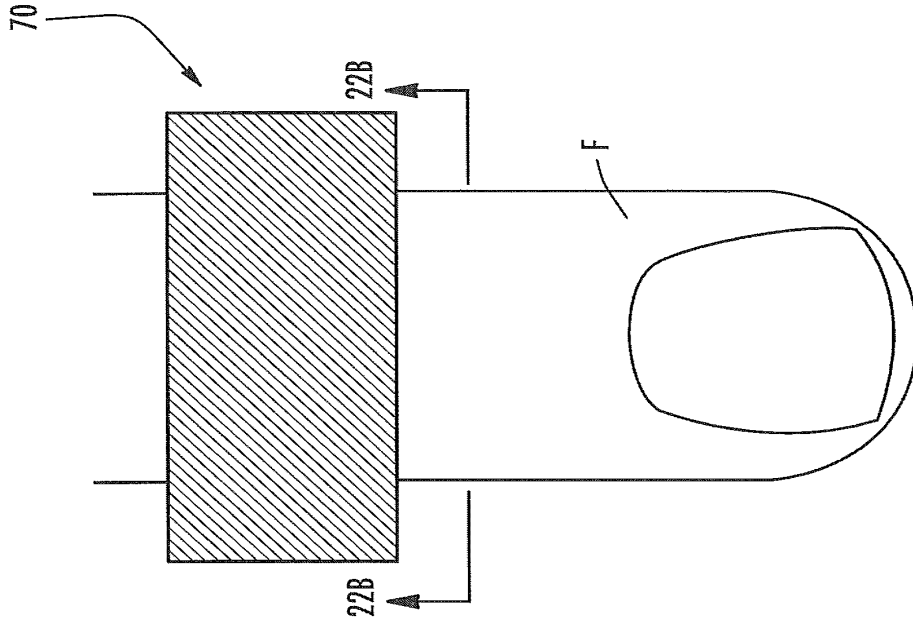

FIG. 22A

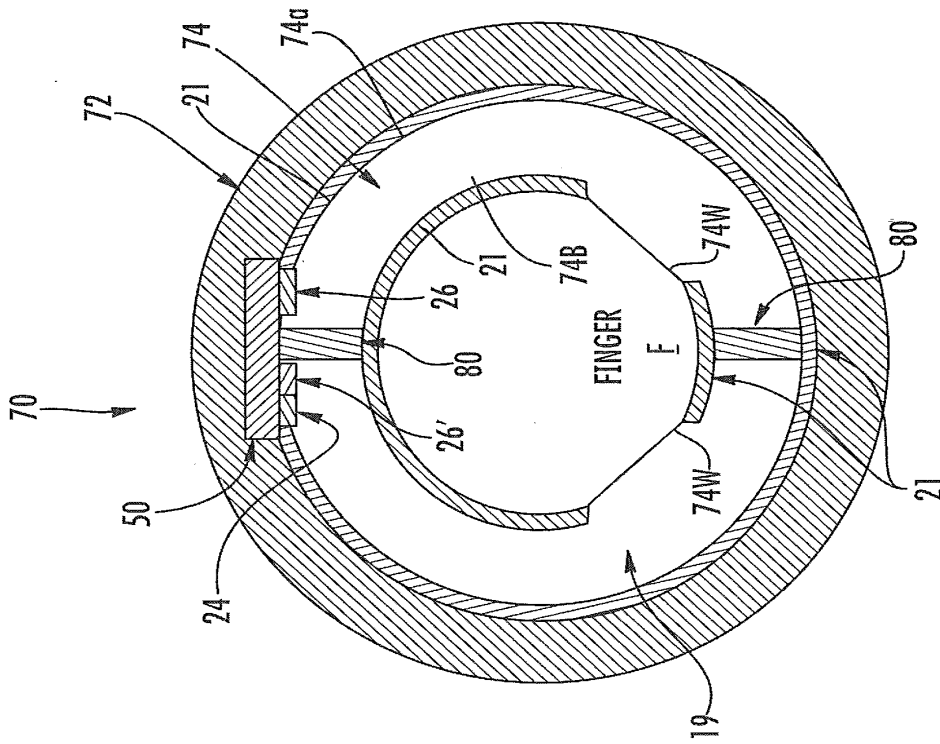

FIG. 22B

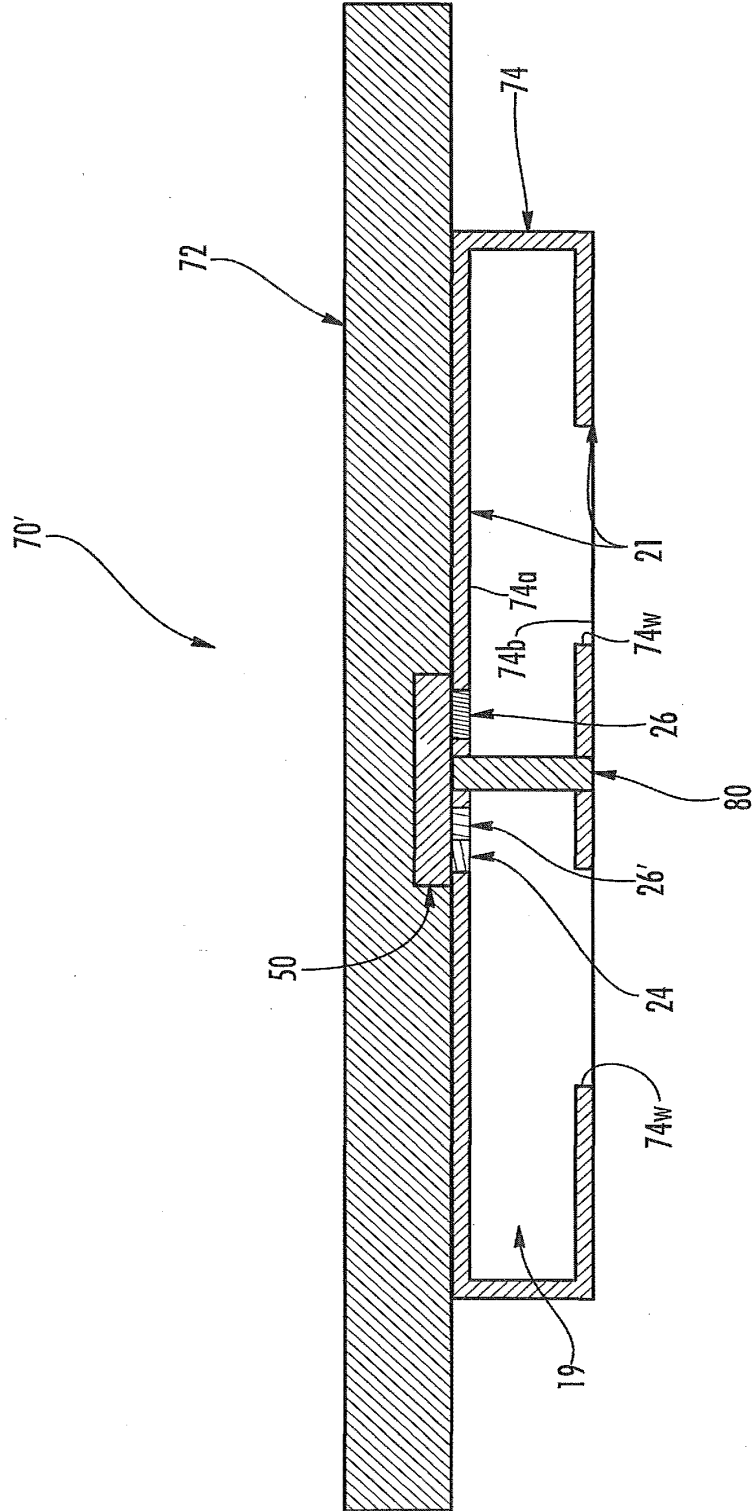

FIG. 23

Under the Paperwork Reduction Act of 1995, no persons are required to respond to a collection of information unless it contains a valid OMB control number.

<b>Application Data Sheet 37 CFR 1.76</b>		Attorney Docket Number	9653-7TSCT5
		Application Number	
Title of Invention	WEARABLE LIGHT-GUIDING DEVICES FOR PHYSIOLOGICAL MONITORING		
The application data sheet is part of the provisional or nonprovisional application for which it is being submitted. The following form contains the bibliographic data arranged in a format specified by the United States Patent and Trademark Office as outlined in 37 CFR 1.76. This document may be completed electronically and submitted to the Office in electronic format using the Electronic Filing System (EFS) or the document may be printed and included in a paper filed application.			

**Secrecy Order 37 CFR 5.2**

<input type="checkbox"/>	Portions or all of the application associated with this Application Data Sheet may fall under a Secrecy Order pursuant to 37 CFR 5.2 (Paper filers only. Applications that fall under Secrecy Order may not be filed electronically.)
--------------------------	---

**Inventor Information:**

<b>Inventor 1</b>					<input type="button" value="Remove"/>
<b>Legal Name</b>					
<b>Prefix</b>	<b>Given Name</b>	<b>Middle Name</b>	<b>Family Name</b>	<b>Suffix</b>	
	Steven	Francis	LeBoeuf		
<b>Residence Information (Select One)</b> <input checked="" type="radio"/> US Residency <input type="radio"/> Non US Residency <input type="radio"/> Active US Military Service					
<b>City</b>	Raleigh	<b>State/Province</b>	NC	<b>Country of Residence</b>	US
<b>Mailing Address of Inventor:</b>					
<b>Address 1</b>	824 Historian Street				
<b>Address 2</b>					
<b>City</b>	Raleigh	<b>State/Province</b>	NC		
<b>Postal Code</b>	27603	<b>Country i</b>	US		
<b>Inventor 2</b>					<input type="button" value="Remove"/>
<b>Legal Name</b>					
<b>Prefix</b>	<b>Given Name</b>	<b>Middle Name</b>	<b>Family Name</b>	<b>Suffix</b>	
	Jesse	Berkley	Tucker		
<b>Residence Information (Select One)</b> <input checked="" type="radio"/> US Residency <input type="radio"/> Non US Residency <input type="radio"/> Active US Military Service					
<b>City</b>	Knightdale	<b>State/Province</b>	NC	<b>Country of Residence</b>	US
<b>Mailing Address of Inventor:</b>					
<b>Address 1</b>	3701 Ramsey Creek Drive				
<b>Address 2</b>					
<b>City</b>	Knightdale	<b>State/Province</b>	NC		
<b>Postal Code</b>	27545	<b>Country i</b>	US		
<b>Inventor 3</b>					<input type="button" value="Remove"/>
<b>Legal Name</b>					
<b>Prefix</b>	<b>Given Name</b>	<b>Middle Name</b>	<b>Family Name</b>	<b>Suffix</b>	
	Michael	Edward	Aumer		
<b>Residence Information (Select One)</b> <input checked="" type="radio"/> US Residency <input type="radio"/> Non US Residency <input type="radio"/> Active US Military Service					

Under the Paperwork Reduction Act of 1995, no persons are required to respond to a collection of information unless it contains a valid OMB control number.

<b>Application Data Sheet 37 CFR 1.76</b>		Attorney Docket Number	9653-7TSCT5		
		Application Number			
Title of Invention	WEARABLE LIGHT-GUIDING DEVICES FOR PHYSIOLOGICAL MONITORING				
City	Raleigh	State/Province	NC	Country of Residence	US
<b>Mailing Address of Inventor:</b>					
Address 1	2218 The Circle				
Address 2					
City	Raleigh	State/Province	NC		
Postal Code	27608	Country	US		
All Inventors Must Be Listed - Additional Inventor Information blocks may be generated within this form by selecting the Add button.					<input type="button" value="Add"/>

**Correspondence Information:**

Enter either Customer Number or complete the Correspondence Information section below. For further information see 37 CFR 1.33(a).	
<input type="checkbox"/> An Address is being provided for the correspondence information of this application.	
Customer Number	20792
Email Address	<input type="button" value="Add Email"/> <input type="button" value="Remove Email"/>

**Application Information:**

Title of the Invention	WEARABLE LIGHT-GUIDING DEVICES FOR PHYSIOLOGICAL MONITORING		
Attorney Docket Number	9653-7TSCT5	Small Entity Status Claimed	<input type="checkbox"/>
Application Type	Nonprovisional		
Subject Matter	Utility		
Total Number of Drawing Sheets (if any)		Suggested Figure for Publication (if any)	

**Filing By Reference :**

Only complete this section when filing an application by reference under 35 U.S.C. 111(c) and 37 CFR 1.57(a). Do not complete this section if application papers including a specification and any drawings are being filed. Any domestic benefit or foreign priority information must be provided in the appropriate section(s) below (i.e., "Domestic Benefit/National Stage Information" and "Foreign Priority Information").

For the purposes of a filing date under 37 CFR 1.53(b), the description and any drawings of the present application are replaced by this reference to the previously filed application, subject to conditions and requirements of 37 CFR 1.57(a).

Application number of the previously filed application	Filing date (YYYY-MM-DD)	Intellectual Property Authority or Country

**Publication Information:**

<input type="checkbox"/> Request Early Publication (Fee required at time of Request 37 CFR 1.219)
<input type="checkbox"/> <b>Request Not to Publish.</b> I hereby request that the attached application not be published under 35 U.S.C. 122(b) and certify that the invention disclosed in the attached application <b>has not and will not</b> be the subject of an application filed in another country, or under a multilateral international agreement, that requires publication at eighteen months after filing.

Under the Paperwork Reduction Act of 1995, no persons are required to respond to a collection of information unless it contains a valid OMB control number.

<b>Application Data Sheet 37 CFR 1.76</b>		Attorney Docket Number	9653-7TSCT5
		Application Number	
Title of Invention	WEARABLE LIGHT-GUIDING DEVICES FOR PHYSIOLOGICAL MONITORING		

### Representative Information:

Representative information should be provided for all practitioners having a power of attorney in the application. Providing this information in the Application Data Sheet does not constitute a power of attorney in the application (see 37 CFR 1.32). Either enter Customer Number or complete the Representative Name section below. If both sections are completed the customer number will be used for the Representative Information during processing.

Please Select One:	<input checked="" type="radio"/> Customer Number	<input type="radio"/> US Patent Practitioner	<input type="radio"/> Limited Recognition (37 CFR 11.9)
Customer Number	20792		

### Domestic Benefit/National Stage Information:

This section allows for the applicant to either claim benefit under 35 U.S.C. 119(e), 120, 121, or 365(c) or indicate National Stage entry from a PCT application. Providing this information in the application data sheet constitutes the specific reference required by 35 U.S.C. 119(e) or 120, and 37 CFR 1.78.

When referring to the current application, please leave the application number blank.

Prior Application Status	Pending		<a href="#">Remove</a>		
Application Number	Continuity Type	Prior Application Number	Filing Date (YYYY-MM-DD)		
	Continuation of	14184364	2014-02-19		
Prior Application Status	Patented		<a href="#">Remove</a>		
Application Number	Continuity Type	Prior Application Number	Filing Date (YYYY-MM-DD)	Patent Number	Issue Date (YYYY-MM-DD)
14184364	Continuation of	12691388	2010-01-21	8700111	2014-04-15
Prior Application Status	Expired		<a href="#">Remove</a>		
Application Number	Continuity Type	Prior Application Number	Filing Date (YYYY-MM-DD)		
12691388	Claims benefit of provisional	61208567	2009-02-25		
Prior Application Status	Expired		<a href="#">Remove</a>		
Application Number	Continuity Type	Prior Application Number	Filing Date (YYYY-MM-DD)		
12691388	Claims benefit of provisional	61208574	2009-02-25		
Prior Application Status	Expired		<a href="#">Remove</a>		
Application Number	Continuity Type	Prior Application Number	Filing Date (YYYY-MM-DD)		
12691388	Claims benefit of provisional	61212444	2009-04-13		
Prior Application Status	Expired		<a href="#">Remove</a>		
Application Number	Continuity Type	Prior Application Number	Filing Date (YYYY-MM-DD)		
12691388	Claims benefit of provisional	61274191	2009-08-14		

Additional Domestic Benefit/National Stage Data may be generated within this form by selecting the **Add** button.



Under the Paperwork Reduction Act of 1995, no persons are required to respond to a collection of information unless it contains a valid OMB control number.

<b>Application Data Sheet 37 CFR 1.76</b>		Attorney Docket Number	9653-7TSCT5
		Application Number	
Title of Invention	WEARABLE LIGHT-GUIDING DEVICES FOR PHYSIOLOGICAL MONITORING		

**Foreign Priority Information:**

This section allows for the applicant to claim priority to a foreign application. Providing this information in the application data sheet constitutes the claim for priority as required by 35 U.S.C. 119(b) and 37 CFR 1.55(d). When priority is claimed to a foreign application that is eligible for retrieval under the priority document exchange program (PDX)<sup>1</sup> the information will be used by the Office to automatically attempt retrieval pursuant to 37 CFR 1.55(h)(1) and (2). Under the PDX program, applicant bears the ultimate responsibility for ensuring that a copy of the foreign application is received by the Office from the participating foreign intellectual property office, or a certified copy of the foreign priority application is filed, within the time period specified in 37 CFR 1.55(g)(1).

<input type="button" value="Remove"/>			
Application Number	Country <sup>1</sup>	Filing Date (YYYY-MM-DD)	Access Code <sup>1</sup> (if applicable)
Additional Foreign Priority Data may be generated within this form by selecting the <b>Add</b> button.			

**Statement under 37 CFR 1.55 or 1.78 for AIA (First Inventor to File) Transition Applications**

<p>This application (1) claims priority to or the benefit of an application filed before March 16, 2013 and (2) also contains, or contained at any time, a claim to a claimed invention that has an effective filing date on or after March 16, 2013.</p> <p><input type="checkbox"/> NOTE: By providing this statement under 37 CFR 1.55 or 1.78, this application, with a filing date on or after March 16, 2013, will be examined under the first inventor to file provisions of the AIA.</p>
--

**Authorization to Permit Access:**

<input checked="" type="checkbox"/> Authorization to Permit Access to the Instant Application by the Participating Offices
--

Under the Paperwork Reduction Act of 1995, no persons are required to respond to a collection of information unless it contains a valid OMB control number.

<b>Application Data Sheet 37 CFR 1.76</b>	Attorney Docket Number	9653-7TSCT5
	Application Number	
Title of Invention	WEARABLE LIGHT-GUIDING DEVICES FOR PHYSIOLOGICAL MONITORING	

If checked, the undersigned hereby grants the USPTO authority to provide the European Patent Office (EPO), the Japan Patent Office (JPO), the Korean Intellectual Property Office (KIPO), the World Intellectual Property Office (WIPO), and any other intellectual property offices in which a foreign application claiming priority to the instant patent application is filed access to the instant patent application. See 37 CFR 1.14(c) and (h). This box should not be checked if the applicant does not wish the EPO, JPO, KIPO, WIPO, or other intellectual property office in which a foreign application claiming priority to the instant patent application is filed to have access to the instant patent application.

In accordance with 37 CFR 1.14(h)(3), access will be provided to a copy of the instant patent application with respect to: 1) the instant patent application-as-filed; 2) any foreign application to which the instant patent application claims priority under 35 U.S.C. 119(a)-(d) if a copy of the foreign application that satisfies the certified copy requirement of 37 CFR 1.55 has been filed in the instant patent application; and 3) any U.S. application-as-filed from which benefit is sought in the instant patent application.

In accordance with 37 CFR 1.14(c), access may be provided to information concerning the date of filing this Authorization.

## Applicant Information:

Providing assignment information in this section does not substitute for compliance with any requirement of part 3 of Title 37 of CFR to have an assignment recorded by the Office.			
<b>Applicant 1</b>			
If the applicant is the inventor (or the remaining joint inventor or inventors under 37 CFR 1.45), this section should not be completed. The information to be provided in this section is the name and address of the legal representative who is the applicant under 37 CFR 1.43; or the name and address of the assignee, person to whom the inventor is under an obligation to assign the invention, or person who otherwise shows sufficient proprietary interest in the matter who is the applicant under 37 CFR 1.46. If the applicant is an applicant under 37 CFR 1.46 (assignee, person to whom the inventor is obligated to assign, or person who otherwise shows sufficient proprietary interest) together with one or more joint inventors, then the joint inventor or inventors who are also the applicant should be identified in this section.			
<input type="button" value="Clear"/>			
<input checked="" type="radio"/> Assignee	<input type="radio"/> Legal Representative under 35 U.S.C. 117	<input type="radio"/> Joint Inventor	
<input type="radio"/> Person to whom the inventor is obligated to assign.		<input type="radio"/> Person who shows sufficient proprietary interest	
If applicant is the legal representative, indicate the authority to file the patent application, the inventor is:			
Name of the Deceased or Legally Incapacitated Inventor : <input type="text"/>			
If the Applicant is an Organization check here. <input checked="" type="checkbox"/>			
Organization Name	Valencell, Inc.		
<b>Mailing Address Information For Applicant:</b>			
Address 1	Landmark Center		
Address 2	4601 Six Forks Rd., Suite 103		
City	Raleigh	State/Province	NC
Country	US	Postal Code	27609
Phone Number		Fax Number	

Under the Paperwork Reduction Act of 1995, no persons are required to respond to a collection of information unless it contains a valid OMB control number.

<b>Application Data Sheet 37 CFR 1.76</b>		Attorney Docket Number	9653-7TSCT5
		Application Number	
Title of Invention	WEARABLE LIGHT-GUIDING DEVICES FOR PHYSIOLOGICAL MONITORING		
Email Address			
Additional Applicant Data may be generated within this form by selecting the Add button.			

**Assignee Information including Non-Applicant Assignee Information:**

Providing assignment information in this section does not substitute for compliance with any requirement of part 3 of Title 37 of CFR to have an assignment recorded by the Office.				
<b>Assignee 1</b>				
Complete this section if assignee information, including non-applicant assignee information, is desired to be included on the patent application publication. An assignee-applicant identified in the "Applicant Information" section will appear on the patent application publication as an applicant. For an assignee-applicant, complete this section only if identification as an assignee is also desired on the patent application publication.				
If the Assignee or Non-Applicant Assignee is an Organization check here. <input type="checkbox"/>				
Prefix	Given Name	Middle Name	Family Name	Suffix
<b>Mailing Address Information For Assignee including Non-Applicant Assignee:</b>				
Address 1				
Address 2				
City		State/Province		
Country <sup>1</sup>	Postal Code			
Phone Number		Fax Number		
Email Address				
Additional Assignee or Non-Applicant Assignee Data may be generated within this form by selecting the Add button.				

**Signature:**

NOTE: This form must be signed in accordance with 37 CFR 1.33. See 37 CFR 1.4 for signature requirements and certifications.					
Signature			Date (YYYY-MM-DD)	2014-09-12	
First Name	Needham J.	Last Name	Boddie, II	Registration Number	40519
Additional Signature may be generated within this form by selecting the Add button.					

Under the Paperwork Reduction Act of 1995, no persons are required to respond to a collection of information unless it contains a valid OMB control number.

<b>Application Data Sheet 37 CFR 1.76</b>	Attorney Docket Number	9653-7TSCT5
	Application Number	
Title of Invention	WEARABLE LIGHT-GUIDING DEVICES FOR PHYSIOLOGICAL MONITORING	

This collection of information is required by 37 CFR 1.76. The information is required to obtain or retain a benefit by the public which is to file (and by the USPTO to process) an application. Confidentiality is governed by 35 U.S.C. 122 and 37 CFR 1.14. This collection is estimated to take 23 minutes to complete, including gathering, preparing, and submitting the completed application data sheet form to the USPTO. Time will vary depending upon the individual case. Any comments on the amount of time you require to complete this form and/or suggestions for reducing this burden, should be sent to the Chief Information Officer, U.S. Patent and Trademark Office, U.S. Department of Commerce, P.O. Box 1450, Alexandria, VA 22313-1450. DO NOT SEND FEES OR COMPLETED FORMS TO THIS ADDRESS. **SEND TO: Commissioner for Patents, P.O. Box 1450, Alexandria, VA 22313-1450.**

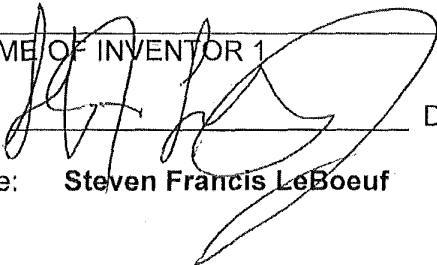
DECLARATION (37 CFR 1.63) FOR UTILITY OR DESIGN APPLICATION USING AN APPLICATION DATA SHEET (37 CFR 1.76)	
<b>Title of Invention</b>	<b>WEARABLE LIGHT-GUIDING DEVICES FOR PHYSIOLOGICAL MONITORING</b>
As a below named inventor, I hereby declare that:	
This declaration is directed to: <input checked="" type="checkbox"/> The attached application, or <input type="checkbox"/> United States application or PCT international application number _____ filed on _____, <input type="checkbox"/> As amended on _____ (if applicable).	
The above-identified application was made or authorized to be made by me.	
I believe that I am the original inventor or an original joint inventor of a claimed invention in the application.	
I have reviewed and understand the contents of the above-identified specification, including the claims, as amended by any amendment specifically referred to above.	
I am aware of the duty to disclose information which is material to patentability as defined in 37 C.F.R. § 1.56, including for continuation-in-part applications, material information that became available between the filing date of the prior application and the national or PCT international filing date of the continuation-in-part application.	
I hereby acknowledge that any willful false statement made in this declaration is punishable under 18 U.S.C. 1001 by fine or imprisonment of not more than five (5) years, or both.	
LEGAL NAME OF INVENTOR 1	
Signature: 	Date: <u>9/8/2014</u>
Legal Name: <b>Steven Francis LeBoeuf</b>	

LEGAL NAME OF INVENTOR 2

Signature: Jesse Berkley Tucker Date: 9/2/2014

Legal Name: **Jesse Berkley Tucker**

LEGAL NAME OF INVENTOR 3

Signature: Michael Edward Aumer Date: 9/8/14

Legal Name: **Michael Edward Aumer**

Under the Paperwork Reduction Act of 1995, no persons are required to respond to a collection of information unless it displays a valid OMB control number.

## TRANSMITTAL FOR POWER OF ATTORNEY TO ONE OR MORE REGISTERED PRACTITIONERS

NOTE: This form is to be submitted with the Power of Attorney by Applicant form (PTO/AIA/82B) to identify the application to which the Power of Attorney is directed, in accordance with 37 CFR 1.5, unless the application number and filing date are identified in the Power of Attorney by Applicant form. If neither form PTO/AIA/82A nor form PTO/AIA82B identifies the application to which the Power of Attorney is directed, the Power of Attorney will not be recognized in the application.

Application Number	To Be Assigned
Filing Date	Concurrently Herewith
First Named Inventor	Steven Francis LeBoeuf
Title	WEARABLE LIGHT-GUIDING DEVICES FOR PHYSIOLOGICAL MONITORING
Art Unit	
Examiner Name	
Attorney Docket Number	9653-7TSCT5

SIGNATURE of Applicant or Patent Practitioner			
Signature		Date (Optional)	September 12, 2014
Name	Needham J. Boddie, II	Registration Number	40,519
Title (if Applicant is a juristic entity)	Attorney		

Applicant Name (if Applicant is a juristic entity)	
--	--

**NOTE:** This form must be signed in accordance with 37 CFR 1.33. See 37 CFR 1.4(d) for signature requirements and certifications. If more than one applicant, use multiple forms.

\*Total of   1   forms are submitted.

This collection of information is required by 37 CFR 1.131, 1.32, and 1.33. The information is required to obtain or retain a benefit by the public which is to file (and by the USPTO to process) an application. Confidentiality is governed by 35 U.S.C. 122 and 37 CFR 1.11 and 1.14. This collection is estimated to take 3 minutes to complete, including gathering, preparing, and submitting the completed application form to the USPTO. Time will vary depending upon the individual case. Any comments on the amount of time you require to complete this form and/or suggestions for reducing this burden, should be sent to the Chief Information Officer, U.S. Patent and Trademark Office, U.S. Department of Commerce, P.O. Box 1450, Alexandria, VA 22313-1450. DO NOT SEND FEES OR COMPLETED FORMS TO THIS ADDRESS. **SEND TO: Commissioner for Patents, P.O. Box 1450, Alexandria, VA 22313-1450.**

*If you need assistance in completing the form, call 1-800-PTO-9199 and select option 2.*

Under the Paperwork Reduction Act of 1995, no persons are required to respond to a collection of information unless it displays a valid OMB control number

## POWER OF ATTORNEY BY APPLICANT

I hereby revoke all previous powers of attorney given in the application identified in either the attached transmittal letter or the boxes below.

Application Number	Filing Date

(Note: The boxes above may be left blank if information is provided on form PTO/AIA/82A.)

- I hereby appoint the Patent Practitioner(s) associated with the following Customer Number as my/our attorney(s) or agent(s), and to transact all business in the United States Patent and Trademark Office connected therewith for the application referenced in the attached transmittal letter (form PTO/AIA/82A) or identified above: 20792
- OR
- I hereby appoint Practitioner(s) named in the attached list (form PTO/AIA/82C) as my/our attorney(s) or agent(s), and to transact all business in the United States Patent and Trademark Office connected therewith for the patent application referenced in the attached transmittal letter (form PTO/AIA/82A) or identified above. (Note: Complete form PTO/AIA/82C.)

**Please recognize or change the correspondence address for the application identified in the attached transmittal letter or the boxes above to:**

- The address associated with the above-mentioned Customer Number
- OR
- The address associated with Customer Number:
- OR

Firm or Individual Name			
Address			
City	State	Zip	
Country			
Telephone	Email		

I am the Applicant (If the Applicant is a Juristic entity, list the Applicant name in the box):

Valencell, Inc.

- Inventor or Joint Inventor (title not required below)
- Legal Representative of a Deceased or Legally Incapacitated Inventor (title not required below)
- Assignee or Person to Whom the Inventor is Under an Obligation to Assign (provide signer's title if applicant is a juristic entity)
- Person Who Otherwise Shows Sufficient Proprietary Interest (e.g., a petition under 37 CFR 1.46(b)(2) was granted in the application or is concurrently being filed with this document) (provide signer's title if applicant is a juristic entity)

### SIGNATURE of Applicant for Patent

The undersigned (whose title is supplied below) is authorized to act on behalf of the applicant (e.g., where the applicant is a juristic entity).

Signature		Date (Optional)	January 24, 2014
Name	Todd Ackman		
Title	Vice President of Finance, Valencell, Inc.		

**NOTE:** Signature - This form must be signed by the applicant in accordance with 37 CFR 1.33. See 37 CFR 1.4 for signature requirements and certifications. If more than one applicant, use multiple forms.

Total of 1 forms are submitted.

This collection of information is required by 37 CFR 1.131, 1.32, and 1.33. The information is required to obtain or retain a benefit by the public which is to file (and by the USPTO to process) an application. Confidentiality is governed by 35 U.S.C. 122 and 37 CFR 1.11 and 1.14. This collection is estimated to take 3 minutes to complete, including gathering, preparing, and submitting the completed application form to the USPTO. Time will vary depending upon the individual case. Any comments on the amount of time you require to complete this form and/or suggestions for reducing this burden, should be sent to the Chief Information Officer, U.S. Patent and Trademark Office, U.S. Department of Commerce, P.O. Box 1460, Alexandria, VA 22313-1460. DO NOT SEND FEES OR COMPLETED FORMS TO THIS ADDRESS. SEND TO: Commissioner for Patents, P.O. Box 1460, Alexandria, VA 22313-1460.

*If you need assistance in completing the form, call 1-800-PTO-9199 and select option 2.*



IN THE UNITED STATES PATENT AND TRADEMARK OFFICE

In re: LeBoeuf et al.  
Serial No.: To Be Assigned  
Filed: Concurrently Herewith  
For: WEARABLE LIGHT-GUIDING DEVICES FOR PHYSIOLOGICAL MONITORING

Date: September 12, 2014

Commissioner for Patents  
Box 1450  
Alexandria, VA 22313-1450

**INFORMATION DISCLOSURE STATEMENT COVER LETTER**

Sir:

Attached is an Information Disclosure Statement listing of documents previously of record in parent Application No. 14/184,364, filed February 19, 2014. As the benefit of this application is claimed under 35 U.S.C. § 120, no copies need to be furnished in accordance with 37 C.F.R. § 1.98(d); however, copies will be furnished on request.

- In accordance with **37 CFR 1.97(b)**, the information disclosure statement is being filed:
- (1) within three months of the filing date of a national application other than a continued prosecution application under §1.53(d);
  - (2) within three months of the date of entry of the national stage as set forth in §1.491 in an international application;
  - (3) before the mailing of a first Office Action on the merits; or
  - (4) before the mailing of a first Office Action after the filing of a request for continued examination under §1.114.

In accordance with **37 CFR 1.97(c)**, the information disclosure statement is being filed after the period specified in 37 CFR 1.97(b) above, but before the mailing date of any of a final action under §1.113, a notice of allowance under §1.311, or an action that otherwise closes prosecution in the application, and is accompanied by **one** of the following:

- (1) The statement specified under **37 CFR 1.97(e)**, as follows:
  - Each item of information contained in the information disclosure statement was first cited in any communication from a foreign patent office in a counterpart foreign application not more than three months prior to the filing of the information disclosure statement; **or**
  - No item of information contained in the information disclosure statement was cited in a communication from a foreign patent office in a counterpart foreign application, and, to the knowledge of the person signing the certification after making reasonable inquiry, no item of information contained in the information disclosure statement was known to any individual designated in §1.56(c) more than three months prior to the filing of the information disclosure statement; **or**
- (2) The fee set forth in §1.17(p);

In accordance with **37 CFR 1.97(d)**, the information disclosure statement is being filed after the period specified in 37 CFR 1.97(c) above, but on or before payment of the issue fee, and is accompanied by **both** of the following:

(1) The statement specified under **37 CFR 1.97(e)**, as follows:

That each item of information contained in the information disclosure statement was first cited in any communication from a foreign patent office in a counterpart foreign application not more than three months prior to the filing of the information disclosure statement; **or**

That no item of information contained in the information disclosure statement was cited in a communication from a foreign patent office in a counterpart foreign application, and, to the knowledge of the person signing the certification after making reasonable inquiry, no item of information contained in the information disclosure statement was known to any individual designated in §1.56(c) more than three months prior to the filing of the information disclosure statement; **and**

(2) The fee set forth in §1.17(p);

In accordance with **37 CFR 1.97(g)**, the information disclosure statement shall not be construed as a representation that a search has been made.

In accordance with **37 CFR 1.97(h)**, the information disclosure statement shall not be construed to be an admission that the information cited in the statement is, or is considered to be, material to patentability as defined in §1.56(b).

The Director is hereby authorized to charge the fee specified in 37 C.F.R. § 1.17(p), and any fee deficiency or credit any overpayment, to Deposit Account No. 50-0220; **or**

No fee is believed due. However, the Director is hereby authorized to charge any deficiency or credit any overpayment to Deposit Account No. 50-0220.

Respectfully submitted,



Needham J. Boddie, II  
Registration No. 40,519  
Attorney for Applicant

**Customer Number 20792**

Myers Bigel Sibley & Sajovec, P.A.  
P.O. Box 37428, Raleigh, NC 27627  
919-854-1400  
919-854-1401 (Fax)

**CERTIFICATION OF TRANSMISSION**

I hereby certify that this correspondence is being transmitted via the Office electronic filing system in accordance with § 1.6(a)(4) to the U.S. Patent and Trademark Office on **September 12, 2014**.

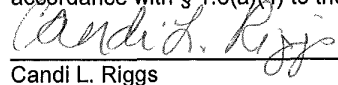
  
Candi L. Riggs

<b>INFORMATION DISCLOSURE STATEMENT BY APPLICANT</b>  (use as many sheets as necessary)			<b>Complete if Known</b>		
			Application Number		
			Filing Date		
			First Named Inventor		Steven Francis LeBoeuf
			Art Unit		
			Examiner Name		
Sheet	<b>A1</b>	of	<b>A2</b>	Attorney Docket Number	9653-7TSCT5

U.S. PATENT DOCUMENTS						
Examiner Initials*	Cite No.	Document Number		Publication Date MM-DD-YYYY	Name of Patentee or Applicant of Cited Document	Pages, Columns, Lines, Where Relevant Passages or Relevant Figures Appear
		Number-Kind Code (if known)				
	1.	US-	8,512,242 B2	08-20-2013	LeBoeuf et al.	
	2.	US-	2013/0131519 A1	05-23-2013	LeBoeuf et al.	
	3.	US-	8,251,903 B2	08-28-2012	LeBoeuf et al.	
	4.	US-	2012/0197093 A1	08-02-2012	LeBoeuf et al.	
	5.	US-	2012/0179011 A1	07-12-2012	Moon et al.	
	6.	US-	8,055,319 B2	11-08-2011	Oh et al.	
	7.	US-	2011/0105869 A1	05-05-2011	Wilson et al.	
	8.	US-	2010/0298653 A1	11-25-2010	McCombie et al.	
	9.	US-	2010/0217103 A1	08-26-2010	Abdul-Hafiz et al.	
	10.	US-	2010/0168531 A1	07-01-2010	Shaltis et al.	
	11.	US-	2009/0287067 A1	11-19-2009	Dorogusker et al.	
	12.	US-	2009/0270698 A1	10-29-2009	Shioi et al.	
	13.	US-	2009/0105556 A1	04-23-2009	Fricke et al.	
	14.	US-	2009/0054752 A1	02-26-2009	Jonnalagadda et al.	
	15.	US-	2009/0030350 A1	01-29-2009	Yang et al.	
	16.	US-	2008/0177162 A1	07-24-2008	Bae et al.	
	17.	US-	2008/0165017 A1	07-10-2008	Schwartz	
	18.	US-	2008/0096726 A1	04-24-2008	Riley et al.	
	19.	US-	2008/0076972 A1	03-27-2008	Dorogusker et al.	
	20.	US-	7,209,775 B2	04-24-2007	Bae et al.	
	21.	US-	7,107,088 B2	09-12-2006	Aceti	
	22.	US-	2006/0009685 A1	01-12-2006	Finarov et al.	
	23.	US-	2005/0228299 A1	10-13-2005	Banet	
	24.	US-	2005/0209516 A1	09-22-2005	Fraden	
	25.	US-	2005/0177034 A1	08-11-2005	Beaumont	
	26.	US-	2005/0043600 A1	02-24-2005	Diab et al.	
	27.	US-	6,859,658 B1	02-22-2005	Krug	
	28.	US-	2004/0225207 A1	11-11-2004	Bae et al.	
	29.	US-	6,808,473 B2	10-26-2004	Hisano et al.	
	30.	US-	6,783,501 B2	08-31-2004	Takahashi et al.	
	31.	US-	2004/0054291 A1	03-18-2004	Schulz et al.	
	32.	US-	2004/0034293 A1	02-19-2004	Kimball	
	33.	US-	2003/0109030 A1	06-12-2003	Uchida et al.	
	34.	US-	6,371,925 B1	04-16-2002	Imai et al.	
	35.	US-	6,358,216 B1	03-19-2002	Kraus et al.	
	36.	US-	6,080,110	06-27-2000	Thorgersen	
	37.	US-	6,078,829	06-20-2000	Uchida et al.	
	38.	US-	5,596,987	01-28-1997	Chance	
	39.	US-	5,086,229	02-04-1992	Rosenthal et al.	
		US-				
		US-				
		US-				

Examiner Signature		Date Considered	
--------------------	--	-----------------	--

\*EXAMINER: Initial if reference considered, whether or not citation is in conformance with MPEP 609. Draw line through citation if not in conformance and not considered. Include copy of this form with next communication to applicant.

<b>INFORMATION DISCLOSURE STATEMENT BY APPLICANT</b>  (use as many sheets as necessary)				<b>Complete if Known</b>			
				Application Number			
				Filing Date			
				First Named Inventor		Steven Francis LeBoeuf	
				Art Unit			
Examiner Name							
Sheet	<b>A2</b>	of	<b>A2</b>	Attorney Docket Number	9653-7TSCT5		

FOREIGN PATENT DOCUMENTS						
Examiner Initials*	Cite No.	Foreign Patent Document	Publication Date MM-DD-YYYY	Name of Patentee or Applicant of Cited Document	Pages, Columns, Lines, Where Relevant Passages or Relevant Figures Appear	T
		Country Code, Number, Kind Code (if known)				
	40.	WO 2013/038296 A1	03-21-2013	KONINKLIJKE PHILIPS ELECTRONICS N.V.		
	41.	EP 2 077 091 A2	07-08-2009	PERCEPTION DIGITAL LIMITED		
	42.	JP 2007-185348	07-26-2007	OLYMPUS CORP		
	43.	JP 2001-025462	01-30-2001	DENSO CORP		
	44.	JP 2000-116611	04-25-2000	KOWA SPINNING CO LTD; KOWA CO		
	45.	JP 9-299342	11-25-1997	IKYO KK		
	46.	JP 9-253062	09-30-1997	IKYO KK		
	47.	JP 7-241279	09-19-1995	NIPPON KODEN CORP		

NON PATENT LITERATURE DOCUMENTS			
Examiner Initials*	Cite No.	Include name of the author (in CAPITAL LETTERS), title of the article (when appropriate), title of the item (book, magazine, journal, serial, symposium, catalog, etc.), date, page(s), volume-issue number(s), publisher, city and/or country where published	T
	48.	FITRAINER "The Only Trainer You Need"; <a href="http://itami.com">http://itami.com</a> ; Downloaded 02-26-2010; ©2008 FitTrainer™; 2 pages	
	49.	Notification of Transmittal of The International Search Report and The Written Opinion of the International Searching Authority, or the Declaration corresponding to International Application No. PCT/US2013/070271; Date of Mailing: 02-26-2014; International Search Report; Written Opinion of the International Searching Authority; 13 pages	
	50.	Notification of Transmittal of the International Search Report and Written Opinion issued 08-26-2010 by the Korean Intellectual Property Office for corresponding International Application No. PCT/US2010/021629	

Examiner Signature		Date Considered	
--------------------	--	-----------------	--

\*EXAMINER: Initial if reference considered, whether or not citation is in conformance with MPEP 609. Draw line through citation if not in conformance and not considered. Include copy of this form with next communication to applicant.

## Electronic Patent Application Fee Transmittal

<b>Application Number:</b>					
<b>Filing Date:</b>					
<b>Title of Invention:</b>	Wearable Light-Guiding Devices For Physiological Monitoring				
<b>First Named Inventor/Applicant Name:</b>	Steven Francis LeBoeuf				
<b>Filer:</b>	Needham J. Boddie/Candi Riggs				
<b>Attorney Docket Number:</b>	9653-7TSCT5				
Filed as Large Entity					
<b>Utility under 35 USC 111(a) Filing Fees</b>					
<b>Description</b>	<b>Fee Code</b>	<b>Quantity</b>	<b>Amount</b>	<b>Sub-Total in USD(\$)</b>	
<b>Basic Filing:</b>					
Utility application filing	1011	1	280	280	
Utility Search Fee	1111	1	600	600	
Utility Examination Fee	1311	1	720	720	
<b>Pages:</b>					
<b>Claims:</b>					
<b>Miscellaneous-Filing:</b>					
<b>Petition:</b>					
<b>Patent-Appeals-and-Interference:</b>					

Description	Fee Code	Quantity	Amount	Sub-Total in USD(\$)
<b>Post-Allowance-and-Post-Issuance:</b>				
<b>Extension-of-Time:</b>				
<b>Miscellaneous:</b>				
<b>Total in USD (\$)</b>				<b>1600</b>

## Electronic Acknowledgement Receipt

<b>EFS ID:</b>	20122568
<b>Application Number:</b>	14484585
<b>International Application Number:</b>	
<b>Confirmation Number:</b>	8375
<b>Title of Invention:</b>	Wearable Light-Guiding Devices For Physiological Monitoring
<b>First Named Inventor/Applicant Name:</b>	Steven Francis LeBoeuf
<b>Customer Number:</b>	20792
<b>Filer:</b>	Needham J. Boddie/Candi Riggs
<b>Filer Authorized By:</b>	Needham J. Boddie
<b>Attorney Docket Number:</b>	9653-7TSCT5
<b>Receipt Date:</b>	12-SEP-2014
<b>Filing Date:</b>	
<b>Time Stamp:</b>	13:12:08
<b>Application Type:</b>	Utility under 35 USC 111(a)

### Payment information:

Submitted with Payment	yes
Payment Type	Deposit Account
Payment was successfully received in RAM	\$ 1600
RAM confirmation Number	10236
Deposit Account	500220
Authorized User	

The Director of the USPTO is hereby authorized to charge indicated fees and credit any overpayment as follows:

Charge any Additional Fees required under 37 C.F.R. Section 1.16 (National application filing, search, and examination fees)

Charge any Additional Fees required under 37 C.F.R. Section 1.17 (Patent application and reexamination processing fees)

<b>File Listing:</b>					
<b>Document Number</b>	<b>Document Description</b>	<b>File Name</b>	<b>File Size(Bytes)/ Message Digest</b>	<b>Multi Part /.zip</b>	<b>Pages (if appl.)</b>
1	Transmittal of New Application	9653-7TSCT5_Transmittal.pdf	138726 c3b461b89a72d7367ce662ed0f345bce7d335eb1	no	1
<b>Warnings:</b>					
<b>Information:</b>					
2		9653-7TSCT5_Specification.pdf	6528069 5f13a41094b76f6aaa5661e0b5d5afcd7e2f45be	yes	51
	<b>Multipart Description/PDF files in .zip description</b>				
	<b>Document Description</b>	<b>Start</b>	<b>End</b>		
	Specification	1	46		
	Claims	47	50		
	Abstract	51	51		
<b>Warnings:</b>					
<b>Information:</b>					
3	Drawings-only black and white line drawings	9653-7TSCT5_Drawings.pdf	1464163 de6a696b9f9687719bbdcf31ed7397a083c3a6e9	no	21
<b>Warnings:</b>					
<b>Information:</b>					
4	Application Data Sheet	9653-7TSCT5_ADS.pdf	819642 451e8d97a8c84adc180bf5cfd354f08eda6d82f2	no	7
<b>Warnings:</b>					
<b>Information:</b>					
This is not an USPTO supplied ADS fillable form					
5	Oath or Declaration filed	9653-7TSCT5_Declaration.pdf	146471 8b2be7f4ca451d55121632e6d28d19cdf7b8e6057	no	2
<b>Warnings:</b>					
<b>Information:</b>					
6	Power of Attorney	9653-7TSCT5_GPOA.pdf	344658 d27f80f794cab05220b4b12da5f9f1c8ac8f7cb2	no	2
<b>Warnings:</b>					
<b>Information:</b>					



7		9653-7TSCT5_IDS.pdf	513657 e4bb2e9e4a429e8061c5767e3b2c5a9fc5026ca6	yes	4
<b>Multipart Description/PDF files in .zip description</b>					
		<b>Document Description</b>	<b>Start</b>	<b>End</b>	
		Transmittal Letter	1	2	
		Information Disclosure Statement (IDS) Form (SB08)	3	4	
<b>Warnings:</b>					
<b>Information:</b>					
8	Fee Worksheet (SB06)	fee-info.pdf	33200 f3366e6191076ebcd00fcd74bbdaa9cc02bc80fe	no	2
<b>Warnings:</b>					
<b>Information:</b>					
<b>Total Files Size (in bytes):</b>			9988586		
<p><b>This Acknowledgement Receipt evidences receipt on the noted date by the USPTO of the indicated documents, characterized by the applicant, and including page counts, where applicable. It serves as evidence of receipt similar to a Post Card, as described in MPEP 503.</b></p> <p><b><u>New Applications Under 35 U.S.C. 111</u></b>  <b>If a new application is being filed and the application includes the necessary components for a filing date (see 37 CFR 1.53(b)-(d) and MPEP 506), a Filing Receipt (37 CFR 1.54) will be issued in due course and the date shown on this Acknowledgement Receipt will establish the filing date of the application.</b></p> <p><b><u>National Stage of an International Application under 35 U.S.C. 371</u></b>  <b>If a timely submission to enter the national stage of an international application is compliant with the conditions of 35 U.S.C. 371 and other applicable requirements a Form PCT/DO/EO/903 indicating acceptance of the application as a national stage submission under 35 U.S.C. 371 will be issued in addition to the Filing Receipt, in due course.</b></p> <p><b><u>New International Application Filed with the USPTO as a Receiving Office</u></b>  <b>If a new international application is being filed and the international application includes the necessary components for an international filing date (see PCT Article 11 and MPEP 1810), a Notification of the International Application Number and of the International Filing Date (Form PCT/RO/105) will be issued in due course, subject to prescriptions concerning national security, and the date shown on this Acknowledgement Receipt will establish the international filing date of the application.</b></p>					

Attorney Docket No.: 9653-7TSCT5

**PATENT**

**IN THE UNITED STATES PATENT AND TRADEMARK OFFICE**

In re: LeBoeuf et al.

Confirmation No.: 8375

Serial No.: 14/484,585

Filed: September 12, 2014

For: WEARABLE LIGHT-GUIDING DEVICES FOR PHYSIOLOGICAL  
MONITORING

Date: September 17, 2014

Mail Stop Amendment  
Commissioner for Patents  
P.O. Box 1450  
Alexandria, VA 22313-1450

**PRELIMINARY AMENDMENT**

Prior to the examination of the above-referenced application, please enter the following amendments and consider the remarks below. Applicants provide the present Amendment pursuant to the rules stated in revised 37 C.F.R. 1.121 that became effective on July 30, 2003.

**Amendments to the Specification** begin on page 2 of this paper.

**Amendments to the Abstract** begin on page 3 of this paper.

**A Listing of the Claims** begin on page 4 of this paper.

**Remarks** begin on page 8 of this paper.

In re: LeBoeuf et al.  
Serial No.: 14/484,585  
Filed: September 12, 2014  
Page 2 of 8

**In the Specification:**

On page 1, please replace the paragraph beginning on line 14 with the follow paragraph:

The present invention relates generally to physiological monitoring and, more particularly, to physiological monitoring devices.

In re: LeBoeuf et al.  
Serial No.: 14/484,585  
Filed: September 12, 2014  
Page 3 of 8

**In the Abstract:**

On page 51, please replace the existing Abstract with the following Abstract:

A monitoring device configured to be attached to the body of a subject includes an outer layer and an inner layer secured together. The inner layer includes light transmissive material and has inner and outer surfaces. A base is secured to at least one of the outer and inner layers and includes an optical emitter and optical detector. A layer of cladding material is positioned near the outer surface of the inner layer, and at least one window is formed in the layer of cladding material that serves as a light-guiding interface to the body of the subject. The light transmissive material delivers light from the optical emitter to the body of the subject along a first direction and collects light from the body of the subject and delivers the collected light in a second direction to the optical detector. The first and second directions are substantially parallel.

**Listing of Claims:**

1. (Original) A monitoring device configured to be attached to the body of a subject, comprising:
  - an outer layer and an inner layer secured together, the inner layer comprising light transmissive material, and having inner and outer surfaces;
  - a base secured to at least one of the outer and inner layers and comprising at least one optical emitter and at least one optical detector;
  - a layer of cladding material near the outer surface of the inner layer; and
  - at least one window formed in the layer of cladding material that serves as a light-guiding interface to the body of the subject, wherein the light transmissive material is in optical communication with the at least one optical emitter and the at least one optical detector, wherein the light transmissive material is configured to deliver light from the at least one optical emitter to the body of the subject along a first direction and to collect light from the body of the subject and deliver the collected light in a second direction to the at least one optical detector, wherein the first and second directions are substantially parallel.
2. (Original) The monitoring device of Claim 1, wherein the at least one window is oriented substantially parallel with a light emitting surface of the at least one optical emitter.
3. (Original) The monitoring device of Claim 1, wherein the at least one window is oriented substantially parallel with a light detecting surface of the at least one optical detector.
4. (Original) The monitoring device of Claim 1, wherein the outer layer and/or inner layer comprises adhesive in one or more locations that is configured to adhesively secure the device to the body of the subject.
5. (Original) The monitoring device of Claim 1, wherein the light transmissive material comprises a lens region in optical communication with the at least one optical emitter that focuses light emitted by the at least one optical emitter.

6. (Original) The monitoring device of Claim 1, further comprising a light reflective material on at least a portion of one or both of the inner and outer surfaces of the inner layer, wherein the at least one optical detector comprises first and second optical detectors, and further comprising a signal processor, and wherein at least a portion of light reflected by the light reflective material and detected by the second optical detector is processed by the signal processor as a motion noise reference for attenuating motion noise from signals produced by the first optical detector.

7. (Original) The monitoring device of Claim 1, wherein the monitoring device further comprises at least one optical filter configured to selectively pass at least one optical wavelength for transmission into the body of the subject, wherein the at least one optical detector comprises first and second optical detectors, and further comprising a signal processor, and wherein at least a portion of light not passed by the optical filter and detected by the second optical detector is processed by the signal processor as a motion noise reference for attenuating motion noise from signals produced by the first optical detector.

8. (Original) The monitoring device of Claim 1, wherein the base comprises a signal processor configured to receive and process signals produced by the at least one optical detector.

9. (Original) The monitoring device of Claim 1, wherein the base comprises a transmitter configured to transmit signals processed by the signal processor to a remote device.

10. (Original) The monitoring device of Claim 1, wherein the at least one window comprises at least two windows, and further comprising light blocking material positioned between the at least one optical emitter and the at least one optical detector such that the at least one optical emitter and the at least one optical detector are not in direct optical communication with each other.

11. (Original) A monitoring device configured to be attached to the body of a subject, comprising:

a first layer comprising light transmissive material, the first layer having inner and outer surfaces;

a base secured to the first layer and comprising at least one optical emitter and at least one optical detector;

a layer of cladding material near the inner and outer surfaces of the first layer; and

at least one window formed in the layer of cladding material that serves as a light-guiding interface to the body of the subject, wherein the light transmissive material is in optical communication with the at least one optical emitter and the at least one optical detector, and is configured to deliver light from the at least one optical emitter to the body of the subject along a first direction and to collect light from the body of the subject and deliver the collected light in a second direction to the at least one optical detector, wherein the first and second directions are substantially parallel.

12. (Original) The monitoring device of Claim 11, wherein the at least one window is oriented substantially parallel with a light emitting surface of the at least one optical emitter.

13. (Original) The monitoring device of Claim 11, wherein the at least one window is oriented substantially parallel with a light detecting surface of the at least one optical detector.

14. (Original) The monitoring device of Claim 11, wherein the first layer comprises adhesive in one or more locations that is configured to adhesively secure the device to the body of the subject.

15. (Original) The monitoring device of Claim 11, wherein the light transmissive material comprises a lens region in optical communication with the at least one optical emitter that focuses light emitted by the at least one optical emitter.

16. (Original) The monitoring device of Claim 11, further comprising a light reflective material on at least a portion of one or both of the inner and outer surfaces of the first layer, wherein the at least one optical detector comprises first and second optical detectors, and further comprising a signal processor, and wherein at least a portion of light reflected by the light reflective material and detected by the second optical detector is processed by the signal processor as a motion noise reference for attenuating motion noise from signals produced by the first optical detector.

17. (Original) The monitoring device of Claim 11, wherein the monitoring device further comprises at least one optical filter configured to selectively pass at least one optical wavelength for transmission into the body of the subject, wherein the at least one optical detector comprises first and second optical detectors, and further comprising a signal processor, and wherein at least a portion of light not passed by the optical filter and detected by the second optical detector is processed by the signal processor as a motion noise reference for attenuating motion noise from signals produced by the first optical detector.

18. (Original) The monitoring device of Claim 11, wherein the base comprises a signal processor configured to receive and process signals produced by the at least one optical detector.

19. (Original) The monitoring device of Claim 11, wherein the base comprises a transmitter configured to transmit signals processed by the signal processor to a remote device.

20. (Original) The monitoring device of Claim 11, wherein the at least one window comprises at least two windows, and further comprising light blocking material positioned between the at least one optical emitter and the at least one optical detector such that the at least one optical emitter and the at least one optical detector are not in direct optical communication with each other.



In re: LeBoeuf et al.  
Serial No.: 14/484,585  
Filed: September 12, 2014  
Page 8 of 8

**REMARKS**

Applicants have amended the Field of the Invention section and the Abstract, as indicated above.

Claims 1-20 are to be examined in the present continuation application. Entry of this Preliminary Amendment, examination of the application, and allowance of the application, including Claims 1-20, are respectfully requested.

Respectfully submitted,



Needham J. Boddie, II  
Attorney for Applicants  
Registration No. 40,519

USPTO Customer No. 20792  
Myers Bigel Sibley & Sajovec, P.A.  
Post Office Box 37428  
Raleigh, North Carolina 27627  
Telephone: (919) 854-1400  
Facsimile: (919) 854-1401  
Doc. No. 1569955

**CERTIFICATION OF TRANSMISSION**

I hereby certify that this correspondence is being transmitted via the Office electronic filing system in accordance with 37 CFR § 1.6(a)(4) to the U.S. Patent and Trademark Office on September 17, 2014.

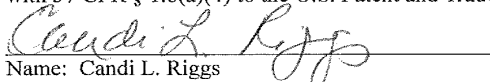
  
Name: Candi L. Riggs

## Electronic Acknowledgement Receipt

<b>EFS ID:</b>	20158897
<b>Application Number:</b>	14484585
<b>International Application Number:</b>	
<b>Confirmation Number:</b>	8375
<b>Title of Invention:</b>	Wearable Light-Guiding Devices For Physiological Monitoring
<b>First Named Inventor/Applicant Name:</b>	Steven Francis LeBoeuf
<b>Customer Number:</b>	20792
<b>Filer:</b>	Needham J. Boddie/Candi Riggs
<b>Filer Authorized By:</b>	Needham J. Boddie
<b>Attorney Docket Number:</b>	9653-7TSCT5
<b>Receipt Date:</b>	17-SEP-2014
<b>Filing Date:</b>	
<b>Time Stamp:</b>	07:24:58
<b>Application Type:</b>	Utility under 35 USC 111(a)

### Payment information:

Submitted with Payment	no
------------------------	----

### File Listing:

Document Number	Document Description	File Name	File Size(Bytes)/ Message Digest	Multi Part /.zip	Pages (if appl.)
1		PreliminaryAmendment.pdf	596365 cd3d453cbdd8887b9eea6932be4e6dec 4c70b1	yes	8

<b>Multipart Description/PDF files in .zip description</b>		
<b>Document Description</b>	<b>Start</b>	<b>End</b>
Preliminary Amendment	1	1
Specification	2	2
Abstract	3	3
Claims	4	7
Applicant Arguments/Remarks Made in an Amendment	8	8

**Warnings:**

**Information:**

**Total Files Size (in bytes):**

596365

This Acknowledgement Receipt evidences receipt on the noted date by the USPTO of the indicated documents, characterized by the applicant, and including page counts, where applicable. It serves as evidence of receipt similar to a Post Card, as described in MPEP 503.

**New Applications Under 35 U.S.C. 111**

If a new application is being filed and the application includes the necessary components for a filing date (see 37 CFR 1.53(b)-(d) and MPEP 506), a Filing Receipt (37 CFR 1.54) will be issued in due course and the date shown on this Acknowledgement Receipt will establish the filing date of the application.

**National Stage of an International Application under 35 U.S.C. 371**

If a timely submission to enter the national stage of an international application is compliant with the conditions of 35 U.S.C. 371 and other applicable requirements a Form PCT/DO/EO/903 indicating acceptance of the application as a national stage submission under 35 U.S.C. 371 will be issued in addition to the Filing Receipt, in due course.

**New International Application Filed with the USPTO as a Receiving Office**

If a new international application is being filed and the international application includes the necessary components for an international filing date (see PCT Article 11 and MPEP 1810), a Notification of the International Application Number and of the International Filing Date (Form PCT/RO/105) will be issued in due course, subject to prescriptions concerning national security, and the date shown on this Acknowledgement Receipt will establish the international filing date of the application.

**PATENT APPLICATION FEE DETERMINATION RECORD**

Substitute for Form PTO-875

Application or Docket Number  
14/484,585

**APPLICATION AS FILED - PART I**

(Column 1)			(Column 2)		SMALL ENTITY		OR	OTHER THAN SMALL ENTITY	
FOR	NUMBER FILED	NUMBER EXTRA	RATE(\$)	FEE(\$)	RATE(\$)	FEE(\$)		RATE(\$)	FEE(\$)
BASIC FEE (37 CFR 1.16(a), (b), or (c))	N/A	N/A	N/A		N/A	280		N/A	280
SEARCH FEE (37 CFR 1.16(k), (i), or (m))	N/A	N/A	N/A		N/A	600		N/A	600
EXAMINATION FEE (37 CFR 1.16(o), (p), or (q))	N/A	N/A	N/A		N/A	720		N/A	720
TOTAL CLAIMS (37 CFR 1.16(i))	20	minus 20 = *			x 80 =	0.00	OR		
INDEPENDENT CLAIMS (37 CFR 1.16(h))	2	minus 3 = *			x 420 =	0.00			
APPLICATION SIZE FEE (37 CFR 1.16(s))	If the specification and drawings exceed 100 sheets of paper, the application size fee due is \$310 (\$155 for small entity) for each additional 50 sheets or fraction thereof. See 35 U.S.C. 41(a)(1)(G) and 37 CFR 1.16(s).								0.00
MULTIPLE DEPENDENT CLAIM PRESENT (37 CFR 1.16(j))									0.00
* If the difference in column 1 is less than zero, enter "0" in column 2.			TOTAL		TOTAL	1600			

**APPLICATION AS AMENDED - PART II**

(Column 1)					(Column 2)		(Column 3)	SMALL ENTITY		OR	OTHER THAN SMALL ENTITY	
AMENDMENT A	CLAIMS REMAINING AFTER AMENDMENT		HIGHEST NUMBER PREVIOUSLY PAID FOR	PRESENT EXTRA	RATE(\$)	ADDITIONAL FEE(\$)		RATE(\$)	ADDITIONAL FEE(\$)			
	Total (37 CFR 1.16(i))	*	Minus	**	=	x	=	OR	x	=		
	Independent (37 CFR 1.16(h))	*	Minus	***	=	x	=	OR	x	=		
	Application Size Fee (37 CFR 1.16(s))							OR				
	FIRST PRESENTATION OF MULTIPLE DEPENDENT CLAIM (37 CFR 1.16(j))							OR				
					TOTAL ADD'L FEE		OR	TOTAL ADD'L FEE				
AMENDMENT B	CLAIMS REMAINING AFTER AMENDMENT		HIGHEST NUMBER PREVIOUSLY PAID FOR	PRESENT EXTRA	RATE(\$)	ADDITIONAL FEE(\$)		RATE(\$)	ADDITIONAL FEE(\$)			
	Total (37 CFR 1.16(i))	*	Minus	**	=	x	=	OR	x	=		
	Independent (37 CFR 1.16(h))	*	Minus	***	=	x	=	OR	x	=		
	Application Size Fee (37 CFR 1.16(s))							OR				
	FIRST PRESENTATION OF MULTIPLE DEPENDENT CLAIM (37 CFR 1.16(j))							OR				
					TOTAL ADD'L FEE		OR	TOTAL ADD'L FEE				

\* If the entry in column 1 is less than the entry in column 2, write "0" in column 3.  
 \*\* If the "Highest Number Previously Paid For" IN THIS SPACE is less than 20, enter "20".  
 \*\*\* If the "Highest Number Previously Paid For" IN THIS SPACE is less than 3, enter "3".  
 The "Highest Number Previously Paid For" (Total or Independent) is the highest found in the appropriate box in column 1.



UNITED STATES PATENT AND TRADEMARK OFFICE

UNITED STATES DEPARTMENT OF COMMERCE
United States Patent and Trademark Office
Address: COMMISSIONER FOR PATENTS
P.O. Box 1450
Alexandria, Virginia 22313-1450
www.uspto.gov

Table with 7 columns: APPLICATION NUMBER, FILING or 371(c) DATE, GRP ART UNIT, FIL FEE REC'D, ATTY DOCKET NO, TOT CLAIMS, IND CLAIMS. Row 1: 14/484,585, 09/12/2014, 2878, 1600, 9653-7TSCT5, 20, 2

CONFIRMATION NO. 8375

20792
MYERS BIGEL SIBLEY & SAJOVEC
PO BOX 37428
RALEIGH, NC 27627

FILING RECEIPT



Date Mailed: 10/22/2014

Receipt is acknowledged of this non-provisional patent application. The application will be taken up for examination in due course. Applicant will be notified as to the results of the examination. Any correspondence concerning the application must include the following identification information: the U.S. APPLICATION NUMBER, FILING DATE, NAME OF APPLICANT, and TITLE OF INVENTION. Fees transmitted by check or draft are subject to collection. Please verify the accuracy of the data presented on this receipt. If an error is noted on this Filing Receipt, please submit a written request for a Filing Receipt Correction. Please provide a copy of this Filing Receipt with the changes noted thereon. If you received a "Notice to File Missing Parts" for this application, please submit any corrections to this Filing Receipt with your reply to the Notice. When the USPTO processes the reply to the Notice, the USPTO will generate another Filing Receipt incorporating the requested corrections

Inventor(s)

Steven Francis LeBoeuf, Raleigh, NC;
Jesse Berkley Tucker, Knightdale, NC;
Michael Edward Aumer, Raleigh, NC;

Applicant(s)

Valencell, Inc., Raleigh, NC

Power of Attorney: The patent practitioners associated with Customer Number 20792

Domestic Priority data as claimed by applicant

This application is a CON of 14/184,364 02/19/2014 PAT 8886269
which is a CON of 12/691,388 01/21/2010 PAT 8700111
which claims benefit of 61/208,567 02/25/2009
and claims benefit of 61/208,574 02/25/2009
and claims benefit of 61/212,444 04/13/2009
and claims benefit of 61/274,191 08/14/2009

Foreign Applications for which priority is claimed (You may be eligible to benefit from the Patent Prosecution Highway program at the USPTO. Please see http://www.uspto.gov for more information.) - None.

Foreign application information must be provided in an Application Data Sheet in order to constitute a claim to foreign priority. See 37 CFR 1.55 and 1.76.

Permission to Access - A proper Authorization to Permit Access to Application by Participating Offices (PTO/SB/39 or its equivalent) has been received by the USPTO.

If Required, Foreign Filing License Granted: 10/22/2014

The country code and number of your priority application, to be used for filing abroad under the Paris Convention, is **US 14/484,585**

**Projected Publication Date:** 01/29/2015

**Non-Publication Request:** No

**Early Publication Request:** No

**Title**

Wearable Light-Guiding Devices For Physiological Monitoring

**Preliminary Class**

250

**Statement under 37 CFR 1.55 or 1.78 for AIA (First Inventor to File) Transition Applications:** No

**PROTECTING YOUR INVENTION OUTSIDE THE UNITED STATES**

Since the rights granted by a U.S. patent extend only throughout the territory of the United States and have no effect in a foreign country, an inventor who wishes patent protection in another country must apply for a patent in a specific country or in regional patent offices. Applicants may wish to consider the filing of an international application under the Patent Cooperation Treaty (PCT). An international (PCT) application generally has the same effect as a regular national patent application in each PCT-member country. The PCT process **simplifies** the filing of patent applications on the same invention in member countries, but **does not result** in a grant of "an international patent" and does not eliminate the need of applicants to file additional documents and fees in countries where patent protection is desired.

Almost every country has its own patent law, and a person desiring a patent in a particular country must make an application for patent in that country in accordance with its particular laws. Since the laws of many countries differ in various respects from the patent law of the United States, applicants are advised to seek guidance from specific foreign countries to ensure that patent rights are not lost prematurely.

Applicants also are advised that in the case of inventions made in the United States, the Director of the USPTO must issue a license before applicants can apply for a patent in a foreign country. The filing of a U.S. patent application serves as a request for a foreign filing license. The application's filing receipt contains further information and guidance as to the status of applicant's license for foreign filing.

Applicants may wish to consult the USPTO booklet, "General Information Concerning Patents" (specifically, the section entitled "Treaties and Foreign Patents") for more information on timeframes and deadlines for filing foreign patent applications. The guide is available either by contacting the USPTO Contact Center at 800-786-9199, or it can be viewed on the USPTO website at <http://www.uspto.gov/web/offices/pac/doc/general/index.html>.

For information on preventing theft of your intellectual property (patents, trademarks and copyrights), you may wish to consult the U.S. Government website, <http://www.stopfakes.gov>. Part of a Department of Commerce initiative, this website includes self-help "toolkits" giving innovators guidance on how to protect intellectual property in specific countries such as China, Korea and Mexico. For questions regarding patent enforcement issues, applicants may call the U.S. Government hotline at 1-866-999-HALT (1-866-999-4258).

**LICENSE FOR FOREIGN FILING UNDER**  
**Title 35, United States Code, Section 184**  
**Title 37, Code of Federal Regulations, 5.11 & 5.15**

**GRANTED**

The applicant has been granted a license under 35 U.S.C. 184, if the phrase "IF REQUIRED, FOREIGN FILING LICENSE GRANTED" followed by a date appears on this form. Such licenses are issued in all applications where the conditions for issuance of a license have been met, regardless of whether or not a license may be required as set forth in 37 CFR 5.15. The scope and limitations of this license are set forth in 37 CFR 5.15(a) unless an earlier license has been issued under 37 CFR 5.15(b). The license is subject to revocation upon written notification. The date indicated is the effective date of the license, unless an earlier license of similar scope has been granted under 37 CFR 5.13 or 5.14.

This license is to be retained by the licensee and may be used at any time on or after the effective date thereof unless it is revoked. This license is automatically transferred to any related applications(s) filed under 37 CFR 1.53(d). This license is not retroactive.

The grant of a license does not in any way lessen the responsibility of a licensee for the security of the subject matter as imposed by any Government contract or the provisions of existing laws relating to espionage and the national security or the export of technical data. Licensees should apprise themselves of current regulations especially with respect to certain countries, of other agencies, particularly the Office of Defense Trade Controls, Department of State (with respect to Arms, Munitions and Implements of War (22 CFR 121-128)); the Bureau of Industry and Security, Department of Commerce (15 CFR parts 730-774); the Office of Foreign Assets Control, Department of Treasury (31 CFR Parts 500+) and the Department of Energy.

**NOT GRANTED**

No license under 35 U.S.C. 184 has been granted at this time, if the phrase "IF REQUIRED, FOREIGN FILING LICENSE GRANTED" DOES NOT appear on this form. Applicant may still petition for a license under 37 CFR 5.12, if a license is desired before the expiration of 6 months from the filing date of the application. If 6 months has lapsed from the filing date of this application and the licensee has not received any indication of a secrecy order under 35 U.S.C. 181, the licensee may foreign file the application pursuant to 37 CFR 5.15(b).

---

***SelectUSA***

The United States represents the largest, most dynamic marketplace in the world and is an unparalleled location for business investment, innovation, and commercialization of new technologies. The U.S. offers tremendous resources and advantages for those who invest and manufacture goods here. Through SelectUSA, our nation works to promote and facilitate business investment. SelectUSA provides information assistance to the international investor community; serves as an ombudsman for existing and potential investors; advocates on behalf of U.S. cities, states, and regions competing for global investment; and counsels U.S. economic development organizations on investment attraction best practices. To learn more about why the United States is the best country in the world to develop technology, manufacture products, deliver services, and grow your business, visit <http://www.SelectUSA.gov> or call +1-202-482-6800.



UNITED STATES PATENT AND TRADEMARK OFFICE

UNITED STATES DEPARTMENT OF COMMERCE  
United States Patent and Trademark Office  
Address: COMMISSIONER FOR PATENTS  
P. O. Box 1450  
Alexandria, Virginia 22313-1450  
www.uspto.gov

APPLICATION NO.	FILING DATE	FIRST NAMED INVENTOR	ATTORNEY DOCKET NO.	CONFIRMATION NO.
14/484,585	09/12/2014	Steven Francis LeBoeuf	9653-7TSCT5	8375

20792 7590 11/12/2014  
MYERS BIGEL SIBLEY & SAJOVEC  
PO BOX 37428  
RALEIGH, NC 27627

EXAMINER
----------

FULLER, RODNEY EVAN

ART UNIT	PAPER NUMBER
2852	

MAIL DATE	DELIVERY MODE
11/12/2014	PAPER

**Please find below and/or attached an Office communication concerning this application or proceeding.**

The time period for reply, if any, is set in the attached communication.



<b>Office Action Summary</b>	<b>Application No.</b> 14/484,585	<b>Applicant(s)</b> LEBOEUF ET AL.	
	<b>Examiner</b> RODNEY FULLER	<b>Art Unit</b> 2852	<b>AIA (First Inventor to File) Status</b> No

-- The MAILING DATE of this communication appears on the cover sheet with the correspondence address --

**Period for Reply**

A SHORTENED STATUTORY PERIOD FOR REPLY IS SET TO EXPIRE 3 MONTHS FROM THE MAILING DATE OF THIS COMMUNICATION.

- Extensions of time may be available under the provisions of 37 CFR 1.136(a). In no event, however, may a reply be timely filed after SIX (6) MONTHS from the mailing date of this communication.
- If NO period for reply is specified above, the maximum statutory period will apply and will expire SIX (6) MONTHS from the mailing date of this communication.
- Failure to reply within the set or extended period for reply will, by statute, cause the application to become ABANDONED (35 U.S.C. § 133). Any reply received by the Office later than three months after the mailing date of this communication, even if timely filed, may reduce any earned patent term adjustment. See 37 CFR 1.704(b).

**Status**

- 1)  Responsive to communication(s) filed on 09/12/2014.  
 A declaration(s)/affidavit(s) under **37 CFR 1.130(b)** was/were filed on \_\_\_\_\_.
- 2a)  This action is **FINAL**.                      2b)  This action is non-final.
- 3)  An election was made by the applicant in response to a restriction requirement set forth during the interview on \_\_\_\_\_; the restriction requirement and election have been incorporated into this action.
- 4)  Since this application is in condition for allowance except for formal matters, prosecution as to the merits is closed in accordance with the practice under *Ex parte Quayle*, 1935 C.D. 11, 453 O.G. 213.

**Disposition of Claims\***

- 5)  Claim(s) 1-20 is/are pending in the application.  
5a) Of the above claim(s) \_\_\_\_\_ is/are withdrawn from consideration.
- 6)  Claim(s) \_\_\_\_\_ is/are allowed.
- 7)  Claim(s) 1-20 is/are rejected.
- 8)  Claim(s) \_\_\_\_\_ is/are objected to.
- 9)  Claim(s) \_\_\_\_\_ are subject to restriction and/or election requirement.

\* If any claims have been determined allowable, you may be eligible to benefit from the **Patent Prosecution Highway** program at a participating intellectual property office for the corresponding application. For more information, please see [http://www.uspto.gov/patents/init\\_events/pph/index.jsp](http://www.uspto.gov/patents/init_events/pph/index.jsp) or send an inquiry to [PPHfeedback@uspto.gov](mailto:PPHfeedback@uspto.gov).

**Application Papers**

- 10)  The specification is objected to by the Examiner.
- 11)  The drawing(s) filed on 09/12/2014 is/are: a)  accepted or b)  objected to by the Examiner.  
Applicant may not request that any objection to the drawing(s) be held in abeyance. See 37 CFR 1.85(a).  
Replacement drawing sheet(s) including the correction is required if the drawing(s) is objected to. See 37 CFR 1.121(d).

**Priority under 35 U.S.C. § 119**

- 12)  Acknowledgment is made of a claim for foreign priority under 35 U.S.C. § 119(a)-(d) or (f).

**Certified copies:**

- a)  All    b)  Some\*\*    c)  None of the:
  - 1.  Certified copies of the priority documents have been received.
  - 2.  Certified copies of the priority documents have been received in Application No. \_\_\_\_\_.
  - 3.  Copies of the certified copies of the priority documents have been received in this National Stage application from the International Bureau (PCT Rule 17.2(a)).

\*\* See the attached detailed Office action for a list of the certified copies not received.

**Attachment(s)**

- 1)  Notice of References Cited (PTO-892)
- 2)  Information Disclosure Statement(s) (PTO/SB/08a and/or PTO/SB/08b)  
Paper No(s)/Mail Date 09/12/2014.
- 3)  Interview Summary (PTO-413)  
Paper No(s)/Mail Date. \_\_\_\_\_.
- 4)  Other: \_\_\_\_\_.

### **DETAILED ACTION**

1. The present application is being examined under the pre-AIA first to invent provisions.

#### ***Double Patenting***

2. The nonstatutory double patenting rejection is based on a judicially created doctrine grounded in public policy (a policy reflected in the statute) so as to prevent the unjustified or improper timewise extension of the “right to exclude” granted by a patent and to prevent possible harassment by multiple assignees. A nonstatutory double patenting rejection is appropriate where the claims at issue are not identical, but at least one examined application claim is not patentably distinct from the reference claim(s) because the examined application claim is either anticipated by, or would have been obvious over, the reference claim(s). See, e.g., *In re Berg*, 140 F.3d 1428, 46 USPQ2d 1226 (Fed. Cir. 1998); *In re Goodman*, 11 F.3d 1046, 29 USPQ2d 2010 (Fed. Cir. 1993); *In re Longi*, 759 F.2d 887, 225 USPQ 645 (Fed. Cir. 1985); *In re Van Ornum*, 686 F.2d 937, 214 USPQ 761 (CCPA 1982); *In re Vogel*, 422 F.2d 438, 164 USPQ 619 (CCPA 1970); and *In re Thorington*, 418 F.2d 528, 163 USPQ 644 (CCPA 1969).

A timely filed terminal disclaimer in compliance with 37 CFR 1.321(c) or 1.321(d) may be used to overcome an actual or provisional rejection based on a nonstatutory double patenting ground provided the reference application or patent either is shown to be commonly owned with this application, or claims an invention made as a result of activities undertaken within the scope of a joint research agreement. A terminal disclaimer must be signed in compliance with 37 CFR 1.321(b).

The USPTO internet Web site contains terminal disclaimer forms which may be used. Please visit <http://www.uspto.gov/forms/>. The filing date of the application will determine what form should be used. A web-based eTerminal Disclaimer may be filled out completely online using web-screens. An eTerminal Disclaimer that meets all requirements is auto-processed and approved immediately upon submission. For more information about eTerminal Disclaimers, refer to

<http://www.uspto.gov/patents/process/file/efs/guidance/eTD-info-I.jsp>.

3. Claims 1-20 are rejected on the ground of nonstatutory double patenting as being unpatentable over claims 1-11 of U.S. Patent No. 8,886,269. Although the claims at issue are not identical, they are not patentably distinct from each other.

4. Claims 1-20 are rejected on the ground of nonstatutory double patenting as being unpatentable over claims 1-42 of U.S. Patent No. 8,700,111. Although the claims at issue are not identical, they are not patentably distinct from each other.

5. Claims 1-20 are provisionally rejected on the ground of nonstatutory double patenting as being unpatentable over claims 1-21 of copending Application No. 14/298,402. Although the claims at issue are not identical, they are not patentably distinct from each other.

This is a provisional nonstatutory double patenting rejection because the patentably indistinct claims have not in fact been patented.

6. Claims 1-20 are provisionally rejected on the ground of nonstatutory double patenting as being unpatentable over claims 1-20 of copending Application No.

14194891. Although the claims at issue are not identical, they are not patentably distinct from each other.

This is a provisional nonstatutory double patenting rejection because the patentably indistinct claims have not in fact been patented.

***Conclusion***

7. Any inquiry concerning this communication or earlier communications from the examiner should be directed to RODNEY FULLER whose telephone number is (571)272-2118. The examiner can normally be reached on 8:00am - 4:30pm.

If attempts to reach the examiner by telephone are unsuccessful, the examiner's supervisor, Clayton Laballe can be reached on 571-272-1594. The fax phone number for the organization where this application or proceeding is assigned is 571-273-8300.

Information regarding the status of an application may be obtained from the Patent Application Information Retrieval (PAIR) system. Status information for published applications may be obtained from either Private PAIR or Public PAIR. Status information for unpublished applications is available through Private PAIR only. For more information about the PAIR system, see <http://pair-direct.uspto.gov>. Should you have questions on access to the Private PAIR system, contact the Electronic Business Center (EBC) at 866-217-9197 (toll-free). If you would like assistance from a USPTO Customer Service Representative or access to the automated information system, call 800-786-9199 (IN USA OR CANADA) or 571-272-1000.

November 4, 2014

/RODNEY FULLER/  
Primary Examiner, Art Unit 2852

Application/Control Number: 14/484,585  
Art Unit: 2852

Page 5

Receipt date: 09/12/2014

14484585 - GAU: 2852

<b>INFORMATION DISCLOSURE STATEMENT BY APPLICANT</b>  <i>(use as many sheets as necessary)</i>			<b>Complete if Known</b>		
			Application Number		
			Filing Date		
			First Named Inventor		Steven Francis LeBoeuf
			Art Unit		
			Examiner Name		
Sheet	<b>A1</b>	of	<b>A2</b>	Attorney Docket Number	9653-7TSCT5

U.S. PATENT DOCUMENTS						
Examiner Initials*	Cite No.	Document Number		Publication Date MM-DD-YYYY	Name of Patentee or Applicant of Cited Document	Pages, Columns, Lines, Where Relevant Passages or Relevant Figures Appear
		Number-Kind Code (if known)				
	1.	US-	8,512,242 B2	08-20-2013	LeBoeuf et al.	
	2.	US-	2013/0131519 A1	05-23-2013	LeBoeuf et al.	
	3.	US-	8,251,903 B2	08-28-2012	LeBoeuf et al.	
	4.	US-	2012/0197093 A1	08-02-2012	LeBoeuf et al.	
	5.	US-	2012/0179011 A1	07-12-2012	Moon et al.	
	6.	US-	8,055,319 B2	11-08-2011	Oh et al.	
	7.	US-	2011/0105869 A1	05-05-2011	Wilson et al.	
	8.	US-	2010/0298653 A1	11-25-2010	McCombie et al.	
	9.	US-	2010/0217103 A1	08-26-2010	Abdul-Hafiz et al.	
	10.	US-	2010/0168531 A1	07-01-2010	Shaltis et al.	
	11.	US-	2009/0287067 A1	11-19-2009	Dorogusker et al.	
	12.	US-	2009/0270698 A1	10-29-2009	Shioi et al.	
	13.	US-	2009/0105556 A1	04-23-2009	Fricke et al.	
	14.	US-	2009/0054752 A1	02-26-2009	Jonnalagadda et al.	
	15.	US-	2009/0030350 A1	01-29-2009	Yang et al.	
	16.	US-	2008/0177162 A1	07-24-2008	Bae et al.	
	17.	US-	2008/0165017 A1	07-10-2008	Schwartz	
	18.	US-	2008/0096726 A1	04-24-2008	Riley et al.	
	19.	US-	2008/0076972 A1	03-27-2008	Dorogusker et al.	
	20.	US-	7,209,775 B2	04-24-2007	Bae et al.	
	21.	US-	7,107,088 B2	09-12-2006	Aceti	
	22.	US-	2006/0009685 A1	01-12-2006	Finarov et al.	
	23.	US-	2005/0228299 A1	10-13-2005	Banet	
	24.	US-	2005/0209516 A1	09-22-2005	Fraden	
	25.	US-	2005/0177034 A1	08-11-2005	Beaumont	
	26.	US-	2005/0043600 A1	02-24-2005	Diab et al.	
	27.	US-	6,859,658 B1	02-22-2005	Krug	
	28.	US-	2004/0225207 A1	11-11-2004	Bae et al.	
	29.	US-	6,808,473 B2	10-26-2004	Hisano et al.	
	30.	US-	6,783,501 B2	08-31-2004	Takahashi et al.	
	31.	US-	2004/0054291 A1	03-18-2004	Schulz et al.	
	32.	US-	2004/0034293 A1	02-19-2004	Kimball	
	33.	US-	2003/0109030 A1	06-12-2003	Uchida et al.	
	34.	US-	6,371,925 B1	04-16-2002	Imai et al.	
	35.	US-	6,358,216 B1	03-19-2002	Kraus et al.	
	36.	US-	6,080,110	06-27-2000	Thorgersen	
	37.	US-	6,078,829	06-20-2000	Uchida et al.	
	38.	US-	5,596,987	01-28-1997	Chance	
	39.	US-	5,086,229	02-04-1992	Rosenthal et al.	
		US-				
		US-				
		US-				

Examiner Signature	/Rodney Fuller/	Date Considered	11/04/2014
--------------------	-----------------	-----------------	------------

\*EXAMINER: Initial if reference considered, whether or not citation is in conformance with MPEP 609. Draw line through citation if not in conformance and not considered. Include copy of this form with next communication to applicant.

ALL REFERENCES CONSIDERED EXCEPT WHERE LINED THROUGH. /RF/

Receipt date: 09/12/2014

14484585 - GAU: 2852

<b>INFORMATION DISCLOSURE STATEMENT BY APPLICANT</b>  (use as many sheets as necessary)				<i>Complete if Known</i>			
				Application Number			
				Filing Date			
				First Named Inventor		Steven Francis LeBoeuf	
				Art Unit			
				Examiner Name			
Sheet	<b>A2</b>	of	<b>A2</b>	Attorney Docket Number	9653-7TSCT5		

FOREIGN PATENT DOCUMENTS						
Examiner Initials*	Cite No.	Foreign Patent Document	Publication Date MM-DD-YYYY	Name of Patentee or Applicant of Cited Document	Pages, Columns, Lines, Where Relevant Passages or Relevant Figures Appear	T
		Country Code, Number, Kind Code (if known)				
	40.	WO 2013/038296 A1	03-21-2013	KONINKLIJKE PHILIPS ELECTRONICS N.V.		
	41.	EP 2 077 091 A2	07-08-2009	PERCEPTION DIGITAL LIMITED		
	42.	JP 2007-185348	07-26-2007	OLYMPUS CORP		
	43.	JP 2001-025462	01-30-2001	DENSO CORP		
	44.	JP 2000-116611	04-25-2000	KOWA SPINNING CO LTD; KOWA CO		
	45.	JP 9-299342	11-25-1997	IKYO KK		
	46.	JP 9-253062	09-30-1997	IKYO KK		
	47.	JP 7-241279	09-19-1995	NIPPON KODEN CORP		

NON PATENT LITERATURE DOCUMENTS			
Examiner Initials*	Cite No.	Include name of the author (in CAPITAL LETTERS), title of the article (when appropriate), title of the item (book, magazine, journal, serial, symposium, catalog, etc.), date, page(s), volume-issue number(s), publisher, city and/or country where published	T
	48.	FITRAINER "The Only Trainer You Need"; <a href="http://itami.com">http://itami.com</a> ; Downloaded 02-26-2010; ©2008 FitTrainer™; 2 pages	
	49.	Notification of Transmittal of The International Search Report and The Written Opinion of the International Searching Authority, or the Declaration corresponding to International Application No. PCT/US2013/070271; Date of Mailing: 02-26-2014; International Search Report; Written Opinion of the International Searching Authority; 13 pages	
	50.	Notification of Transmittal of the International Search Report and Written Opinion issued 08-26-2010 by the Korean Intellectual Property Office for corresponding International Application No. PCT/US2010/021629	

ALL REFERENCES CONSIDERED EXCEPT WHERE LINED THROUGH. /RF/

Examiner Signature	/Rodney Fuller/	Date Considered	11/04/2014
--------------------	-----------------	-----------------	------------

\*EXAMINER: Initial if reference considered, whether or not citation is in conformance with MPEP 609. Draw line through citation if not in conformance and not considered. Include copy of this form with next communication to applicant.

## EAST Search History

## EAST Search History (Prior Art)

Ref #	Hits	Search Query	DBs	Default Operator	Plurals	Time Stamp
L1	0	("8886269").PN.	US-PGPUB; USPAT; USOCR	OR	OFF	2014/11/04 09:29
L2	1	("8700111").PN.	US-PGPUB; USPAT; USOCR	OR	OFF	2014/11/04 09:29
L3	1	2 and parallel	US-PGPUB; USPAT; USOCR; FPRS; EPO; JPO; DERWENT; IBM_TDB	OR	ON	2014/11/04 09:30
L4	148	leboeuf-stein-francis.in.	US-PGPUB; USPAT; USOCR; FPRS; EPO; JPO; DERWENT; IBM_TDB	OR	ON	2014/11/04 09:37
L5	88	tucker-jesse-berkley.in.	US-PGPUB; USPAT; USOCR; FPRS; EPO; JPO; DERWENT; IBM_TDB	OR	ON	2014/11/04 09:38
L6	68	aumer-michael-edward.in.	US-PGPUB; USPAT; USOCR; FPRS; EPO; JPO; DERWENT; IBM_TDB	OR	ON	2014/11/04 09:38
L7	163	4 or 5 or 6	US-PGPUB; USPAT; USOCR; FPRS; EPO; JPO; DERWENT; IBM_TDB	OR	ON	2014/11/04 09:38
L8	23	7 and cladding	US-PGPUB; USPAT; USOCR; FPRS; EPO; JPO; DERWENT; IBM_TDB	OR	ON	2014/11/04 09:38
L9	10	7 and (cladding with window)	US-PGPUB; USPAT;	OR	ON	2014/11/04 09:38



			USOCR; FPRS; EPO; JPO; DERWENT; IBM_TDB			
L10	48	(cladding and window and layer and base).clm.	US-PGPUB; USPAT; USOCR; FPRS; EPO; JPO; DERWENT; IBM_TDB	OR	ON	2014/11/04 09:39
L11	2	9 and 10	US-PGPUB; USPAT; USOCR; FPRS; EPO; JPO; DERWENT; IBM_TDB	OR	ON	2014/11/04 09:39
L12	1	(("8886269") or ("8700111")).PN.	US-PGPUB; USPAT; USOCR	OR	OFF	2014/11/04 09:46
L13	26	("20050177034"   "20050209516"   "20050228299"   "20060009685"   "20080076972"   "20080096726"   "20080165017"   "20080177162"   "20090030350"   "20090054752"   "20090105556"   "20090270698"   "20090287067"   "20110105869"   "20120197093"   "20130131519"   "6078829"   "6080110"   "6371925"   "6783501"   "6808473"   "6859658"   "7209775"   "8055319"   "8251903"   "8512242").PN. OR ("8700111").URPN.	US-PGPUB; USPAT; USOCR	OR	ON	2014/11/04 10:31
L14	26	("20050177034"   "20050209516"   "20050228299"   "20060009685"   "20080076972"   "20080096726"   "20080165017"   "20080177162"   "20090030350"   "20090054752"   "20090105556"   "20090270698"   "20090287067"   "20110105869"   "20120197093"   "20130131519"   "6078829"   "6080110"   "6371925"   "6783501"   "6808473"   "6859658"   "7209775"   "8055319"   "8251903"   "8512242").PN. OR ("8700111").URPN.	US-PGPUB; USPAT; USOCR	OR	ON	2014/11/04 10:32
L15	38	(("8512242") or ("20130131519") or ("8251903") or ("20120197093") or ("20120179011") or ("8055319") or ("20110105869") or ("20100298653") or ("20100217103") or ("20100168531") or ("20090287067") or ("20090270698") or ("20090105556") or ("20090054752") or ("20090030350") or ("20080177162") or ("20080165017") or ("20080096726") or ("20080076972") or ("7209775") or ("7107088") or ("20060009685") or ("20050228299") or ("20050209516") or ("20050177034") or ("20050043600") or ("6859658") or ("20040225207") or ("6873501") or ("20040054291") or ("20040034293") or ("20030109030") or	US-PGPUB; USPAT; USOCR	OR	OFF	2014/11/04 10:37

## EAST Search History

		("6371925") or ("6358216") or ("6080110") or ("6078829") or ("5596987") or ("5086229")).FN. or (68/084773).APP.				
L16	40	13 or 14 or 15	US-PGPUB; USPAT; USOCR; FPRS; EPO; JPO; DERWENT; IBM_TDB	OR	ON	2014/11/04 11:06
L17	4	16 and cladding	US-PGPUB; USPAT; USOCR; FPRS; EPO; JPO; DERWENT; IBM_TDB	OR	ON	2014/11/04 11:08
L18	4691	((600/310) or (600/322) or (600/323) or (600/324)).CCLS.	US-PGPUB; USPAT; USOCR	OR	OFF	2014/11/04 11:09
L19	23	8 and cladding	US-PGPUB; USPAT; USOCR; FPRS; EPO; JPO; DERWENT; IBM_TDB	OR	ON	2014/11/04 11:09
L20	10	8 and (cladding with (window or aperture))	US-PGPUB; USPAT; USOCR; FPRS; EPO; JPO; DERWENT; IBM_TDB	OR	ON	2014/11/04 11:09
L21	8	oximeter and (cladding with (window or aperture))	US-PGPUB; USPAT; USOCR; FPRS; EPO; JPO; DERWENT; IBM_TDB	OR	ON	2014/11/04 11:10
L22	173329	"600"/\$.ccls.	US-PGPUB; USPAT; USOCR; FPRS; EPO; JPO; DERWENT; IBM_TDB	OR	ON	2014/11/04 11:11
L23	180	22 and (cladding with (window or aperture))	US-PGPUB; USPAT; USOCR; FPRS; EPO; JPO; DERWENT; IBM_TDB	OR	ON	2014/11/04 11:11
S66	39	("20090287067"   "20100298653"   "6078829"   "20060009685"   "20120197093"   "5086229"   "6371925"   "6859658"   "20050209516"   "20080177162"   "20090105556"	US-PGPUB; USPAT; USOCR	OR	ON	2014/11/04 08:47

		"20100168531"   "6080110"   "20080076972"   "20090030350"   "5596987"   "6358216"   "7107088"   "6783501"   "20090270698"   "20110105869"   "20130131519"   "7209775"   "8512242"   "20040034293"   "20050043600"   "20050177034"   "20050228299"   "20080096726"   "20090054752"   "6808473"   "8251903"   "20040054291"   "20100217103"   "20080162017"   "8055319"   "20030109030"   "20040225207"   "20120179011").PN.				
S67	39	("20050228299"   "6371925"   "7209775"   "20100298653"   "20080165017"   "20090105556"   "20110105869"   "20120197093"   "8055319"   "5086229"   "20050177034"   "8251903"   "20100168531"   "20040225207"   "20080076972"   "20080096726"   "20080177162"   "6078829"   "6783501"   "6808473"   "5596987"   "6358216"   "7107088"   "20060009685"   "20090054752"   "20130131519"   "6859658"   "20050209516"   "20090030350"   "20090270698"   "8512242"   "20050043600"   "20040034293"   "20090287067"   "6080110"   "20040054291"   "20100217103"   "20080177162"   "20030109030"   "20120179011").PN.	US-PGPUB; USPAT; USOCR	OR	ON	2014/11/04 08:47
S68	14	("20100217103"   "20100298653"   "5086229"   "7107088"   "20040054291"   "20100168531"   "20090054752"   "5596987"   "20040034293"   "20060009685"   "20050043600"   "20120179011"   "20030109030"   "6358215").PN.	US-PGPUB; USPAT; USOCR	OR	ON	2014/11/04 08:48
S69	39	("20050228299"   "20090287067"   "20100298653"   "6078829"   "20120197093"   "5086229"   "6080110"   "6371925"   "6859658"   "20080177162"   "20090105556"   "20100168531"   "20080076972"   "20090030350"   "5596987"   "6783501"   "20090054752"   "6358216"   "7107088"   "20060009685"   "20090270698"   "20110105869"   "20130131519"   "7209775"   "8512242"   "8055319"   "20050043600"   "20050177034"   "20050209516"   "20080096726"   "20080165017"   "20090054752"   "6808473"   "8251903"   "20040034293"   "20120179011"   "20040054291"   "20100217103"   "8055319"   "20030109030"   "20040225207").PN.	US-PGPUB; USPAT; USOCR	OR	ON	2014/11/04 08:48
S70	39	("20090287067"   "20100298653"   "6078829"   "20060009685"   "20120197093"   "5086229"   "6371925"   "6859658"   "20020091049"   "20050209516"   "20080177162"	US-PGPUB; USPAT; USOCR	OR	ON	2014/11/04 08:48

		"20090105556"   "20100168531"   "6080110"   "20040225207"   "6783501"   "20090030350"   "5596987"   "6358216"   "7107088"   "20090270698"   "20110105869"   "20130131519"   "7209775"   "8512242"   "20040034293"   "20050043600"   "20050177034"   "20050228299"   "20080096726"   "20080165017"   "20090054752"   "6808473"   "8251903"   "20040054291"   "20100217103"   "20120179011"   "8055319"   "20030109030").PN.				
S71	2	(( "8700111" ) or ( "8788002" ) ).PN.	US-PGPUB; USPAT; USOCR	OR	OFF	2014/11/04 08:48
S72	33	(( "20040034293"   "20040054291"   "20050043600"   "20050177034"   "20050209516"   "20050228299"   "20060009685"   "20080076972"   "20080096726"   "20080165017"   "20080177162"   "20090030350"   "20090054752"   "20090105556"   "20090270698"   "20090287067"   "20100168531"   "20100217103"   "20100298653"   "20110105869"   "20120197093"   "20130131519"   "5086229"   "5596987"   "6078829"   "6080110"   "6371925"   "6808473"   "6859658"   "7209775"   "8055319"   "8251903"   "8512242" ).PN. OR ( "8788002" ).URPN.	US-PGPUB; USPAT; USOCR	OR	ON	2014/11/04 08:48
S73	26	(( "20050177034"   "20050209516"   "20050228299"   "20060009685"   "20080076972"   "20080096726"   "20080165017"   "20080177162"   "20090030350"   "20090054752"   "20090105556"   "20090270698"   "20090287067"   "20110105869"   "20120197093"   "20130131519"   "6078829"   "6080110"   "6371925"   "6783501"   "6808473"   "6859658"   "7209775"   "8055319"   "8251903"   "8512242" ).PN. OR ( "8700111" ).URPN.	US-PGPUB; USPAT; USOCR	OR	ON	2014/11/04 08:49
S74	44	S66 or S67 or S68 or S69 or S70 or S71 or S72 or S73	US-PGPUB; USPAT; USOCR	OR	ON	2014/11/04 08:49
S75	4691	(( (600/310) or (600/322) or (600/323) or (600/324) ).CCLS.	US-PGPUB; USPAT; USOCR	OR	OFF	2014/11/04 08:52
S76	1455	S75 and housing	US-PGPUB; USPAT; USOCR; FPRS; EPO; JPO; DERWENT; IBM_TDB	OR	ON	2014/11/04 08:52
S77	730	S76 and ((light adj guide) or light-guide or lightguide or fiber or waveguide or wave-guide or (wave adj guide))	US-PGPUB; USPAT; USOCR; FPRS; EPO; JPO; DERWENT;	OR	ON	2014/11/04 08:53

EAST Search History

			IBM_TDB			
S78	14	S77 and (end adj surface)	US-PGPUB; USPAT; USOCR; FPRS; EPO; JPO; DERWENT; IBM_TDB	OR	ON	2014/11/04 08:53
S79	0	S74 and (directly with collect)	US-PGPUB; USPAT; USOCR; FPRS; EPO; JPO; DERWENT; IBM_TDB	OR	ON	2014/11/04 08:55
S80	0	S74 and (directly with collect)	US-PGPUB; USPAT; USOCR; FPRS; EPO; JPO; DERWENT; IBM_TDB	OR	ON	2014/11/04 08:55
S81	2	S74 and (exposed with (fiber or guide))	US-PGPUB; USPAT; USOCR; FPRS; EPO; JPO; DERWENT; IBM_TDB	OR	ON	2014/11/04 08:56
S82	27983	(emitter or light) with (detector or sensor) with housing	US-PGPUB; USPAT; USOCR; FPRS; EPO; JPO; DERWENT; IBM_TDB	OR	ON	2014/11/04 08:56
S83	490	S75 and S82	US-PGPUB; USPAT; USOCR; FPRS; EPO; JPO; DERWENT; IBM_TDB	OR	ON	2014/11/04 08:56
S84	1	S83 and (deliver with directly)	US-PGPUB; USPAT; USOCR; FPRS; EPO; JPO; DERWENT; IBM_TDB	OR	ON	2014/11/04 08:57
S85	47	S83 and (body with directly)	US-PGPUB; USPAT; USOCR; FPRS; EPO; JPO; DERWENT; IBM_TDB	OR	ON	2014/11/04 08:57
S86	12	("20050197550"   "20050251004"   "20060084852"   "20060089585"   "20070197886"   "20080242958"   "20090143657"   "20090182209"	US-PGPUB; USPAT; USOCR	OR	ON	2014/11/04 08:59

## EAST Search History

		"20100049018"   "20120046530"   "6519484"   "6745061").PN. OR ("8670812").URPN.				
S87	26	S74 and housing	US-PGPUB; USPAT; USOCR	OR	ON	2014/11/04 09:00
S88	2	("2013/0131519").URPN.	USPAT	OR	ON	2014/11/04 09:00
S89	2	("2012/0197093").URPN.	USPAT	OR	ON	2014/11/04 09:00
S90	0	("2012/0179011").URPN.	USPAT	OR	ON	2014/11/04 09:00
S91	19	("2010/0298653").URPN.	USPAT	OR	ON	2014/11/04 09:00
S92	7	("2010/0217103").URPN.	USPAT	OR	ON	2014/11/04 09:01
S93	21	("2009/0287067").URPN.	USPAT	OR	ON	2014/11/04 09:01
S94	38	("2006/0009685").URPN.	USPAT	OR	ON	2014/11/04 09:01
S95	18	("2005/0209516").URPN.	USPAT	OR	ON	2014/11/04 09:01
S96	97	("2005/0043600").URPN.	USPAT	OR	ON	2014/11/04 09:01
S97	170	S88 or S89 or S90 or S91 or S92 or S93 or S94 or S95 or S96	USPAT	OR	ON	2014/11/04 09:02

11/ 4/ 2014 11:14:03 AM

C:\Users\rfuller\Documents\EAST\Workspaces\rodney9.wsp

<b>Search Notes</b>  	<b>Application/Control No.</b>  14484585	<b>Applicant(s)/Patent Under Reexamination</b>  LEBOEUF ET AL.
	<b>Examiner</b>  RODNEY FULLER	<b>Art Unit</b>  2852

CPC- SEARCHED		
Symbol	Date	Examiner

CPC COMBINATION SETS - SEARCHED		
Symbol	Date	Examiner

US CLASSIFICATION SEARCHED			
Class	Subclass	Date	Examiner
600	310	11/4/2014	/RF/

SEARCH NOTES		
Search Notes	Date	Examiner
600/310, 322, 323, 324 (w/ text search)	11/4/2014	/RF/
East text search history printout	11/4/2014	/RF/

INTERFERENCE SEARCH			
US Class/ CPC Symbol	US Subclass / CPC Group	Date	Examiner

	/RODNEY FULLER/ Primary Examiner.Art Unit 2852
--	---



UNITED STATES PATENT AND TRADEMARK OFFICE

UNITED STATES DEPARTMENT OF COMMERCE  
 United States Patent and Trademark Office  
 Address: COMMISSIONER FOR PATENTS  
 P.O. Box 1450  
 Alexandria, Virginia 22313-1450  
 www.uspto.gov

BIB DATA SHEET

CONFIRMATION NO. 8375

SERIAL NUMBER	FILING or 371(c) DATE	CLASS	GROUP ART UNIT	ATTORNEY DOCKET NO.
14/484,585	09/12/2014	600	2852	9653-7TSCT5
	<b>RULE</b>			

**APPLICANTS**

Valencell, Inc., Raleigh, NC, Assignee (with 37 CFR 1.172 Interest);

**INVENTORS**

Steven Francis LeBoeuf, Raleigh, NC;  
 Jesse Berkley Tucker, Knightdale, NC;  
 Michael Edward Aumer, Raleigh, NC;

**\*\* CONTINUING DATA \*\*\*\*\***

This application is a CON of 14/184,364 02/19/2014 PAT 8886269  
 which is a CON of 12/691,388 01/21/2010 PAT 8700111  
 which claims benefit of 61/208,567 02/25/2009  
 and claims benefit of 61/208,574 02/25/2009  
 and claims benefit of 61/212,444 04/13/2009  
 and claims benefit of 61/274,191 08/14/2009

**\*\* FOREIGN APPLICATIONS \*\*\*\*\***

**\*\* IF REQUIRED, FOREIGN FILING LICENSE GRANTED \*\***  
 10/22/2014

Foreign Priority claimed <input type="checkbox"/> Yes <input checked="" type="checkbox"/> No	<input type="checkbox"/> Met after Allowance	<b>STATE OR COUNTRY</b>	<b>SHEETS DRAWINGS</b>	<b>TOTAL CLAIMS</b>	<b>INDEPENDENT CLAIMS</b>
35 USC 119(a-d) conditions met <input type="checkbox"/> Yes <input checked="" type="checkbox"/> No		NC	21	20	2
Verified and /RODNEY EVAN FULLER/	Initials				
Acknowledged	Examiner's Signature				

**ADDRESS**

MYERS BIGEL SIBLEY & SAJOVEC  
 PO BOX 37428  
 RALEIGH, NC 27627  
 UNITED STATES

**TITLE**

Wearable Light-Guiding Devices For Physiological Monitoring

<b>FILING FEE RECEIVED</b> 1600	FEES: Authority has been given in Paper No. _____ to charge/credit DEPOSIT ACCOUNT No. _____ for following:	<input type="checkbox"/> All Fees
		<input type="checkbox"/> 1.16 Fees (Filing)
		<input type="checkbox"/> 1.17 Fees (Processing Ext. of time)
		<input type="checkbox"/> 1.18 Fees (Issue)
		<input type="checkbox"/> Other _____
		<input type="checkbox"/> Credit



Attorney Docket No.: 9653-7TSCT5

**PATENT**

**IN THE UNITED STATES PATENT AND TRADEMARK OFFICE**

In re: LeBoeuf et al.

Confirmation No.: 8375

Serial No.: 14/484,585

Group Art Unit: 2852

Filed: September 12, 2014

Examiner: Rodney Evan Fuller

For: WEARABLE LIGHT-GUIDING DEVICES FOR PHYSIOLOGICAL  
MONITORING

Date: November 18, 2014

Mail Stop Amendment  
Commissioner for Patents  
P. O. Box 1450  
Alexandria, VA 22313-1450

**RESPONSE TO OFFICE ACTION OF NOVEMBER 12, 2014**

Applicants provide the present Response to address the issues raised in the Office Action (the "Action") mailed November 12, 2014. Applicants provide the present Response pursuant to the rules stated in revised 37 C.F.R. 1.121 that became effective on July 30, 2003.

It is not believed that an extension of time and/or additional fee(s)-including fees for net addition of claims-are required, beyond those that may otherwise be provided for in documents accompanying this paper. In the event, however, that an extension of time is necessary to allow consideration of this paper, such an extension is hereby petitioned under 37 C.F.R. §1.136(a). Any additional fees believed to be due in connection with this paper may be charged to our Deposit Account No. 50-0220.

**Amendments** to the claims begin on Page 3 of this paper.

**Remarks** begin on Page 7 of this paper.

In re: LeBoeuf et al.  
Serial No. 14/484,585  
Filed: September 12, 2014  
Page 2

This listing of claims replaces all prior versions in the application.

**Listing of Claims:**

1. (Original) A monitoring device configured to be attached to the body of a subject, comprising:
  - an outer layer and an inner layer secured together, the inner layer comprising light transmissive material, and having inner and outer surfaces;
  - a base secured to at least one of the outer and inner layers and comprising at least one optical emitter and at least one optical detector;
  - a layer of cladding material near the outer surface of the inner layer; and
  - at least one window formed in the layer of cladding material that serves as a light-guiding interface to the body of the subject, wherein the light transmissive material is in optical communication with the at least one optical emitter and the at least one optical detector, wherein the light transmissive material is configured to deliver light from the at least one optical emitter to the body of the subject along a first direction and to collect light from the body of the subject and deliver the collected light in a second direction to the at least one optical detector, wherein the first and second directions are substantially parallel.
  
2. (Original) The monitoring device of Claim 1, wherein the at least one window is oriented substantially parallel with a light emitting surface of the at least one optical emitter.
  
3. (Original) The monitoring device of Claim 1, wherein the at least one window is oriented substantially parallel with a light detecting surface of the at least one optical detector.
  
4. (Original) The monitoring device of Claim 1, wherein the outer layer and/or inner layer comprises adhesive in one or more locations that is configured to adhesively secure the device to the body of the subject.

5. (Original) The monitoring device of Claim 1, wherein the light transmissive material comprises a lens region in optical communication with the at least one optical emitter that focuses light emitted by the at least one optical emitter.

6. (Original) The monitoring device of Claim 1, further comprising a light reflective material on at least a portion of one or both of the inner and outer surfaces of the inner layer, wherein the at least one optical detector comprises first and second optical detectors, and further comprising a signal processor, and wherein at least a portion of light reflected by the light reflective material and detected by the second optical detector is processed by the signal processor as a motion noise reference for attenuating motion noise from signals produced by the first optical detector.

7. (Original) The monitoring device of Claim 1, wherein the monitoring device further comprises at least one optical filter configured to selectively pass at least one optical wavelength for transmission into the body of the subject, wherein the at least one optical detector comprises first and second optical detectors, and further comprising a signal processor, and wherein at least a portion of light not passed by the optical filter and detected by the second optical detector is processed by the signal processor as a motion noise reference for attenuating motion noise from signals produced by the first optical detector.

8. (Original) The monitoring device of Claim 1, wherein the base comprises a signal processor configured to receive and process signals produced by the at least one optical detector.

9. (Original) The monitoring device of Claim 1, wherein the base comprises a transmitter configured to transmit signals processed by the signal processor to a remote device.

10. (Original) The monitoring device of Claim 1, wherein the at least one window comprises at least two windows, and further comprising light blocking material positioned between the at least one optical emitter and the at least one optical detector such that the at

In re: LeBoeuf et al.  
Serial No. 14/484,585  
Filed: September 12, 2014  
Page 4

least one optical emitter and the at least one optical detector are not in direct optical communication with each other.

11. (Original) A monitoring device configured to be attached to the body of a subject, comprising:

a first layer comprising light transmissive material, the first layer having inner and outer surfaces;

a base secured to the first layer and comprising at least one optical emitter and at least one optical detector;

a layer of cladding material near the inner and outer surfaces of the first layer; and

at least one window formed in the layer of cladding material that serves as a light-guiding interface to the body of the subject, wherein the light transmissive material is in optical communication with the at least one optical emitter and the at least one optical detector, and is configured to deliver light from the at least one optical emitter to the body of the subject along a first direction and to collect light from the body of the subject and deliver the collected light in a second direction to the at least one optical detector, wherein the first and second directions are substantially parallel.

12. (Original) The monitoring device of Claim 11, wherein the at least one window is oriented substantially parallel with a light emitting surface of the at least one optical emitter.

13. (Original) The monitoring device of Claim 11, wherein the at least one window is oriented substantially parallel with a light detecting surface of the at least one optical detector.

14. (Original) The monitoring device of Claim 11, wherein the first layer comprises adhesive in one or more locations that is configured to adhesively secure the device to the body of the subject.

15. (Original) The monitoring device of Claim 11, wherein the light transmissive material comprises a lens region in optical communication with the at least one optical emitter that focuses light emitted by the at least one optical emitter.

16. (Original) The monitoring device of Claim 11, further comprising a light reflective material on at least a portion of one or both of the inner and outer surfaces of the first layer, wherein the at least one optical detector comprises first and second optical detectors, and further comprising a signal processor, and wherein at least a portion of light reflected by the light reflective material and detected by the second optical detector is processed by the signal processor as a motion noise reference for attenuating motion noise from signals produced by the first optical detector.

17. (Original) The monitoring device of Claim 11, wherein the monitoring device further comprises at least one optical filter configured to selectively pass at least one optical wavelength for transmission into the body of the subject, wherein the at least one optical detector comprises first and second optical detectors, and further comprising a signal processor, and wherein at least a portion of light not passed by the optical filter and detected by the second optical detector is processed by the signal processor as a motion noise reference for attenuating motion noise from signals produced by the first optical detector.

18. (Original) The monitoring device of Claim 11, wherein the base comprises a signal processor configured to receive and process signals produced by the at least one optical detector.

19. (Original) The monitoring device of Claim 11, wherein the base comprises a transmitter configured to transmit signals processed by the signal processor to a remote device.

20. (Original) The monitoring device of Claim 11, wherein the at least one window comprises at least two windows, and further comprising light blocking material positioned between the at least one optical emitter and the at least one optical detector such

---

In re: LeBoeuf et al.  
Serial No. 14/484,585  
Filed: September 12, 2014  
Page 6

that the at least one optical emitter and the at least one optical detector are not in direct optical communication with each other.

In re: LeBoeuf et al.  
Serial No. 14/484,585  
Filed: September 12, 2014  
Page 7

**REMARKS**

Claims 1-20 are pending.

Claims 1-20 stand rejected on the grounds of nonstatutory double patenting as being unpatentable over Claims 1-11 of U.S. Patent No. 8,886,269, and over Claims 1-42 of U.S. Patent No. 8,700,111.

Claims 1-20 stand provisionally rejected on the grounds of nonstatutory double patenting as being unpatentable over Claims 1-21 of copending Application No. 14/298,402, and over Claims 1-20 of copending Application No. 14/194,891.

In order to advance the present application to allowance, Terminal Disclaimers are being filed concurrently to overcome the non-statutory obviousness-type double patenting rejection based on U.S. Patent Nos. 8,886,269 and 8,700,111, and based on co-pending U.S. Patent Application Nos. 14/298,402 and 14/194,891. The filing of these Terminal Disclaimers shall not be construed as an admission that the claims are unpatentable under the judicially created doctrine of obviousness-type double patenting or are obvious under 35 USC §103.

In view of the above, it is respectfully submitted that this application is in condition for allowance, which action is respectfully requested.

Respectfully submitted,



Needham J. Boddie, II  
Attorney for Applicants  
Registration No. 40,519

USPTO Customer No. 20792  
Myers Bigel Sibley & Sajovec, P.A.  
Post Office Box 37428  
Raleigh, North Carolina 27627  
Telephone: (919) 854-1400  
Facsimile: (919) 854-1401  
Doc. No. 1608144

**CERTIFICATION OF TRANSMISSION**

I hereby certify that this correspondence is being transmitted via the Office electronic filing system in accordance with 37 C.F.R. § 1.6(a)(4) to the U.S. Patent and Trademark Office on **November 18, 2014**.

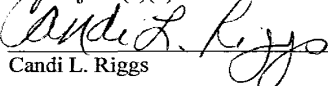
  
Candi L. Riggs

## Electronic Acknowledgement Receipt

<b>EFS ID:</b>	20729280
<b>Application Number:</b>	14484585
<b>International Application Number:</b>	
<b>Confirmation Number:</b>	8375
<b>Title of Invention:</b>	Wearable Light-Guiding Devices For Physiological Monitoring
<b>First Named Inventor/Applicant Name:</b>	Steven Francis LeBoeuf
<b>Customer Number:</b>	20792
<b>Filer:</b>	Needham J. Boddie/Candi Riggs
<b>Filer Authorized By:</b>	Needham J. Boddie
<b>Attorney Docket Number:</b>	9653-7TSCT5
<b>Receipt Date:</b>	18-NOV-2014
<b>Filing Date:</b>	12-SEP-2014
<b>Time Stamp:</b>	14:48:08
<b>Application Type:</b>	Utility under 35 USC 111(a)

### Payment information:

Submitted with Payment	no
------------------------	----

### File Listing:

Document Number	Document Description	File Name	File Size(Bytes)/ Message Digest	Multi Part /.zip	Pages (if appl.)
1		9653-7TSCT5_Response.pdf	574555 0d9ce65e11b318a25306c8263b322e4099a a71e9	yes	7



<b>Multipart Description/PDF files in .zip description</b>		
<b>Document Description</b>	<b>Start</b>	<b>End</b>
Amendment/Req. Reconsideration-After Non-Final Reject	1	1
Claims	2	6
Applicant Arguments/Remarks Made in an Amendment	7	7
<b>Warnings:</b>		
<b>Information:</b>		
<b>Total Files Size (in bytes):</b>	574555	
<p>This Acknowledgement Receipt evidences receipt on the noted date by the USPTO of the indicated documents, characterized by the applicant, and including page counts, where applicable. It serves as evidence of receipt similar to a Post Card, as described in MPEP 503.</p> <p><b><u>New Applications Under 35 U.S.C. 111</u></b>  If a new application is being filed and the application includes the necessary components for a filing date (see 37 CFR 1.53(b)-(d) and MPEP 506), a Filing Receipt (37 CFR 1.54) will be issued in due course and the date shown on this Acknowledgement Receipt will establish the filing date of the application.</p> <p><b><u>National Stage of an International Application under 35 U.S.C. 371</u></b>  If a timely submission to enter the national stage of an international application is compliant with the conditions of 35 U.S.C. 371 and other applicable requirements a Form PCT/DO/EO/903 indicating acceptance of the application as a national stage submission under 35 U.S.C. 371 will be issued in addition to the Filing Receipt, in due course.</p> <p><b><u>New International Application Filed with the USPTO as a Receiving Office</u></b>  If a new international application is being filed and the international application includes the necessary components for an international filing date (see PCT Article 11 and MPEP 1810), a Notification of the International Application Number and of the International Filing Date (Form PCT/RO/105) will be issued in due course, subject to prescriptions concerning national security, and the date shown on this Acknowledgement Receipt will establish the international filing date of the application.</p>		

<b>Doc Code: DIST.E.FILE</b> <b>Document Description: Electronic Terminal Disclaimer - Filed</b>	PTO/SB/25 PTO/SB/26 U.S. Patent and Trademark Office Department of Commerce
---	--

Electronic Petition Request	<b>TERMINAL DISCLAIMER TO OBTAIN A PROVISIONAL DOUBLE PATENTING REJECTION OVER A PENDING "REFERENCE" APPLICATION AND TERMINAL DISCLAIMER TO OBTAIN A DOUBLE PATENTING REJECTION OVER A "PRIOR" PATENT</b>
-----------------------------	---

Application Number	14484585
--------------------	----------

Filing Date	12-Sep-2014
-------------	-------------

First Named Inventor	Steven LeBoeuf
----------------------	----------------

Attorney Docket Number	9653-7TSCT5
------------------------	-------------

Title of Invention	Wearable Light-Guiding Devices For Physiological Monitoring
--------------------	---

Filing of terminal disclaimer does not obviate requirement for response under 37 CFR 1.111 to outstanding Office Action

This electronic Terminal Disclaimer is not being used for a Joint Research Agreement.

Owner	Percent Interest
Valencell, Inc.	100 %

The owner(s) of percent interest listed above in the instant application hereby disclaims, except as provided below, the terminal part of the statutory term of any patent granted on the instant application which would extend beyond the expiration date of the full statutory term of any patent granted on pending reference Application Number(s)

14298402 filed on 06/06/2014  
14194891 filed on 03/03/2014

as the term of any patent granted on said reference application may be shortened by any terminal disclaimer filed prior to the grant of any patent on the pending reference application. The owner hereby agrees that any patent so granted on the instant application shall be enforceable only for and during such period that it and any patent granted on the reference application are commonly owned. This agreement runs with any patent granted on the instant application and is binding upon the grantee, its successors or assigns.

In making the above disclaimer, the owner does not disclaim the terminal part of any patent granted on the instant application that would extend to the expiration date of the full statutory term of any patent granted on said reference application, "as the term of any patent granted on said reference application may be shortened by any terminal disclaimer filed prior to the grant of any patent on the pending reference application," in the event that any such patent granted on the pending reference application: expires for failure to pay a maintenance fee, is held unenforceable, is found invalid by a court of competent jurisdiction, is statutorily disclaimed in whole or terminally disclaimed under 37 CFR 1.321, has all claims canceled by a reexamination certificate, is reissued, or is in any manner terminated prior to the expiration of its full statutory term as shortened by any terminal disclaimer filed prior to its grant.

The owner(s) with percent interest listed above in the instant application hereby disclaims, except as provided below, the terminal part of the statutory term of any patent granted on the instant application which would extend beyond the expiration date of the full statutory term of prior patent number(s)

8886269

8700111

as the term of said prior patent is presently shortened by any terminal disclaimer. The owner hereby agrees that any patent so granted on the instant application shall be enforceable only for and during such period that it and the prior patent are commonly owned. This agreement runs with any patent granted on the instant application and is binding upon the grantee, its successors or assigns.

In making the above disclaimer, the owner does not disclaim the terminal part of the term of any patent granted on the instant application that would extend to the expiration date of the full statutory term of the prior patent, "as the term of said prior patent is presently shortened by any terminal disclaimer," in the event that said prior patent later:

- expires for failure to pay a maintenance fee;
- is held unenforceable;
- is found invalid by a court of competent jurisdiction;
- is statutorily disclaimed in whole or terminally disclaimed under 37 CFR 1.321;
- has all claims canceled by a reexamination certificate;
- is reissued; or
- is in any manner terminated prior to the expiration of its full statutory term as presently shortened by any terminal disclaimer.

Terminal disclaimer fee under 37 CFR 1.20(d) is included with Electronic Terminal Disclaimer request.

I certify, in accordance with 37 CFR 1.4(d)(4), that the terminal disclaimer fee under 37 CFR 1.20(d) required for this terminal disclaimer has already been paid in the above-identified application.

Applicants claims the following fee status:

Small Entity

Micro Entity

Regular Undiscounted

I hereby declare that all statements made herein of my own knowledge are true and that all statements made on information and belief are believed to be true; and further that these statements were made with the knowledge that willful false statements and the like so made are punishable by fine or imprisonment, or both, under Section 1001 of Title 18 of the United States Code and that such willful false statements may jeopardize the validity of the application or any patent issued thereon.

THIS PORTION MUST BE COMPLETED BY THE SIGNATORY OR SIGNATORIES

I certify, in accordance with 37 CFR 1.4(d)(4) that I am:

An attorney or agent registered to practice before the Patent and Trademark Office who is of record in this application

Registration Number 40519

A sole inventor

A joint inventor; I certify that I am authorized to sign this submission on behalf of all of the inventors as evidenced by the power of attorney in the application

A joint inventor; all of whom are signing this request

Signature	/Needham J. Boddie II/
Name	Needham J. Boddie II

\*Statement under 37 CFR 3.73(b) is required if terminal disclaimer is signed by the assignee (owner).  
Form PTO/SB/96 may be used for making this certification. See MPEP § 324.

## Electronic Patent Application Fee Transmittal

<b>Application Number:</b>	14484585			
<b>Filing Date:</b>	12-Sep-2014			
<b>Title of Invention:</b>	Wearable Light-Guiding Devices For Physiological Monitoring			
<b>First Named Inventor/Applicant Name:</b>	Steven Francis LeBoeuf			
<b>Filer:</b>	Needham J. Boddie/Candi Riggs			
<b>Attorney Docket Number:</b>	9653-7TSCT5			
Filed as Large Entity				
<b>Utility under 35 USC 111(a) Filing Fees</b>				
<b>Description</b>	<b>Fee Code</b>	<b>Quantity</b>	<b>Amount</b>	<b>Sub-Total in USD(\$)</b>
<b>Basic Filing:</b>				
Statutory or Terminal Disclaimer	1814	1	160	160
<b>Pages:</b>				
<b>Claims:</b>				
<b>Miscellaneous-Filing:</b>				
<b>Petition:</b>				
<b>Patent-Appeals-and-Interference:</b>				
<b>Post-Allowance-and-Post-Issuance:</b>				
<b>Extension-of-Time:</b>				

Description	Fee Code	Quantity	Amount	Sub-Total in USD(\$)
<b>Miscellaneous:</b>				
<b>Total in USD (\$)</b>				<b>160</b>

Doc Code: DISQ.E.FILE

Document Description: Electronic Terminal Disclaimer – Approved

Application No.: 14484585

Filing Date: 12-Sep-2014

Applicant/Patent under Reexamination: LeBoeuf et al.

Electronic Terminal Disclaimer filed on November 18, 2014

APPROVED

**This patent is subject to a terminal disclaimer**

DISAPPROVED

Approved/Disapproved by: Electronic Terminal Disclaimer automatically approved by EFS-Web

U.S. Patent and Trademark Office

## Electronic Acknowledgement Receipt

<b>EFS ID:</b>	20723791
<b>Application Number:</b>	14484585
<b>International Application Number:</b>	
<b>Confirmation Number:</b>	8375
<b>Title of Invention:</b>	Wearable Light-Guiding Devices For Physiological Monitoring
<b>First Named Inventor/Applicant Name:</b>	Steven Francis LeBoeuf
<b>Customer Number:</b>	20792
<b>Filer:</b>	Needham J. Boddie/Candi Riggs
<b>Filer Authorized By:</b>	Needham J. Boddie
<b>Attorney Docket Number:</b>	9653-7TSCT5
<b>Receipt Date:</b>	18-NOV-2014
<b>Filing Date:</b>	12-SEP-2014
<b>Time Stamp:</b>	14:50:28
<b>Application Type:</b>	Utility under 35 USC 111(a)

### Payment information:

Submitted with Payment	yes
Payment Type	Deposit Account
Payment was successfully received in RAM	\$160
RAM confirmation Number	1067
Deposit Account	500220
Authorized User	

### File Listing:

Document Number	Document Description	File Name	File Size(Bytes)/ Message Digest	Multi Part /.zip	Pages (if appl.)
-----------------	----------------------	-----------	-------------------------------------	------------------	------------------



1	Electronic Terminal Disclaimer-Filed	eTerminal-Disclaimer.pdf	37310 4ec0b287922f236e985448fd3be60a94f2ab6b78	no	3
<b>Warnings:</b>					
<b>Information:</b>					
2	Fee Worksheet (SB06)	fee-info.pdf	30421 a094f0edb0d73f3439a29b344f2add65ec3755bb	no	2
<b>Warnings:</b>					
<b>Information:</b>					
<b>Total Files Size (in bytes):</b>				67731	
<p><b>This Acknowledgement Receipt evidences receipt on the noted date by the USPTO of the indicated documents, characterized by the applicant, and including page counts, where applicable. It serves as evidence of receipt similar to a Post Card, as described in MPEP 503.</b></p> <p><b><u>New Applications Under 35 U.S.C. 111</u></b>  <b>If a new application is being filed and the application includes the necessary components for a filing date (see 37 CFR 1.53(b)-(d) and MPEP 506), a Filing Receipt (37 CFR 1.54) will be issued in due course and the date shown on this Acknowledgement Receipt will establish the filing date of the application.</b></p> <p><b><u>National Stage of an International Application under 35 U.S.C. 371</u></b>  <b>If a timely submission to enter the national stage of an international application is compliant with the conditions of 35 U.S.C. 371 and other applicable requirements a Form PCT/DO/EO/903 indicating acceptance of the application as a national stage submission under 35 U.S.C. 371 will be issued in addition to the Filing Receipt, in due course.</b></p> <p><b><u>New International Application Filed with the USPTO as a Receiving Office</u></b>  <b>If a new international application is being filed and the international application includes the necessary components for an international filing date (see PCT Article 11 and MPEP 1810), a Notification of the International Application Number and of the International Filing Date (Form PCT/RO/105) will be issued in due course, subject to prescriptions concerning national security, and the date shown on this Acknowledgement Receipt will establish the international filing date of the application.</b></p>					

Under the Paperwork Reduction Act of 1995, no persons are required to respond to a collection of information unless it displays a valid OMB control number.

<b>PATENT APPLICATION FEE DETERMINATION RECORD</b> Substitute for Form PTO-875	Application or Docket Number <b>14/484,585</b>	Filing Date <b>09/12/2014</b>	<input type="checkbox"/> To be Mailed
---	---	----------------------------------	---------------------------------------

ENTITY:  LARGE  SMALL  MICRO

**APPLICATION AS FILED – PART I**

FOR	NUMBER FILED	NUMBER EXTRA	RATE (\$)	FEE (\$)
<input type="checkbox"/> BASIC FEE (37 CFR 1.16(a), (b), or (c))	N/A	N/A	N/A	
<input type="checkbox"/> SEARCH FEE (37 CFR 1.16(k), (i), or (m))	N/A	N/A	N/A	
<input type="checkbox"/> EXAMINATION FEE (37 CFR 1.16(o), (p), or (q))	N/A	N/A	N/A	
TOTAL CLAIMS (37 CFR 1.16(i))	minus 20 = *	*	X \$ =	
INDEPENDENT CLAIMS (37 CFR 1.16(h))	minus 3 = *	*	X \$ =	
<input type="checkbox"/> APPLICATION SIZE FEE (37 CFR 1.16(s))	If the specification and drawings exceed 100 sheets of paper, the application size fee due is \$310 (\$155 for small entity) for each additional 50 sheets or fraction thereof. See 35 U.S.C. 41(a)(1)(G) and 37 CFR 1.16(s).			
<input type="checkbox"/> MULTIPLE DEPENDENT CLAIM PRESENT (37 CFR 1.16(j))				
* If the difference in column 1 is less than zero, enter "0" in column 2.			TOTAL	

**APPLICATION AS AMENDED – PART II**

	(Column 1)	(Column 2)	(Column 3)	(Column 3)	RATE (\$)	ADDITIONAL FEE (\$)
<b>AMENDMENT</b>	<b>11/18/2014</b>	CLAIMS REMAINING AFTER AMENDMENT	HIGHEST NUMBER PREVIOUSLY PAID FOR	PRESENT EXTRA		
	Total (37 CFR 1.16(i))	* 20	Minus	** 20	= 0	
	Independent (37 CFR 1.16(h))	* 2	Minus	***3	= 0	
	<input type="checkbox"/> Application Size Fee (37 CFR 1.16(s))					
<input type="checkbox"/> FIRST PRESENTATION OF MULTIPLE DEPENDENT CLAIM (37 CFR 1.16(j))						
					TOTAL ADD'L FEE	<b>0</b>

	(Column 1)	(Column 2)	(Column 3)	(Column 3)	RATE (\$)	ADDITIONAL FEE (\$)
<b>AMENDMENT</b>		CLAIMS REMAINING AFTER AMENDMENT	HIGHEST NUMBER PREVIOUSLY PAID FOR	PRESENT EXTRA		
	Total (37 CFR 1.16(i))	*	Minus	**	=	
	Independent (37 CFR 1.16(h))	*	Minus	***	=	
	<input type="checkbox"/> Application Size Fee (37 CFR 1.16(s))					
<input type="checkbox"/> FIRST PRESENTATION OF MULTIPLE DEPENDENT CLAIM (37 CFR 1.16(j))						
					TOTAL ADD'L FEE	

\* If the entry in column 1 is less than the entry in column 2, write "0" in column 3.  
 \*\* If the "Highest Number Previously Paid For" IN THIS SPACE is less than 20, enter "20".  
 \*\*\* If the "Highest Number Previously Paid For" IN THIS SPACE is less than 3, enter "3".

The "Highest Number Previously Paid For" (Total or Independent) is the highest number found in the appropriate box in column 1.

LIE  
/CORALIA BETANCOURT/

This collection of information is required by 37 CFR 1.16. The information is required to obtain or retain a benefit by the public which is to file (and by the USPTO to process) an application. Confidentiality is governed by 35 U.S.C. 122 and 37 CFR 1.14. This collection is estimated to take 12 minutes to complete, including gathering, preparing, and submitting the completed application form to the USPTO. Time will vary depending upon the individual case. Any comments on the amount of time you require to complete this form and/or suggestions for reducing this burden, should be sent to the Chief Information Officer, U.S. Patent and Trademark Office, U.S. Department of Commerce, P.O. Box 1450, Alexandria, VA 22313-1450. DO NOT SEND FEES OR COMPLETED FORMS TO THIS ADDRESS. **SEND TO: Commissioner for Patents, P.O. Box 1450, Alexandria, VA 22313-1450.**

If you need assistance in completing the form, call 1-800-PTO-9199 and select option 2.

<b>INFORMATION DISCLOSURE STATEMENT BY APPLICANT</b>  (use as many sheets as necessary)			<b>Complete if Known</b>		
			Application Number	14/484,585	
			Filing Date	September 12, 2014	
			First Named Inventor	Steven Francis LeBoeuf	
			Art Unit	2852	
			Examiner Name	Fuller, Rodney Evan	
Sheet	<b>B1</b>	of	<b>B8</b>	Attorney Docket Number	9653-7TSCT5

U.S. PATENT DOCUMENTS						
Examiner Initials*	Cite No.	Document Number		Publication Date MM-DD-YYYY	Name of Patentee or Applicant of Cited Document	Pages, Columns, Lines, Where Relevant Passages or Relevant Figures Appear
		Number-Kind Code (if known)				
	1.	US-	2014/0219467 A1	08-07-2014	Kurtz	
	2.	US-	8,730,048 B2	05-20-2014	Shen et al.	
	3.	US-	2014/0051940 A1	02-20-2014	Messerschmidt	
	4.	US-	2013/0336495 A1	12-19-2013	Burgett et al.	
	5.	US-	2013/0245387 A1	09-19-2013	Patel	
	6.	US-	8,506,524	08-13-2013	Graskov et al.	
	7.	US-	8,504,679 B2	08-06-2013	Spire et al.	
	8.	US-	8,416,959 B2	04-09-2013	Lott et al.	
	9.	US-	8,328,420 B2	12-11-2012	Abreu	
	10.	US-	2012/0277548 A1	11-01-2012	Burton	
	11.	US-	2012/0095303 A1	04-19-2012	He	
	12.	US-	8,137,270 B2	03-20-2012	Keenan et al.	
	13.	US-	8,130,105 B2	03-06-2012	Al-Ali et al.	
	14.	US-	2012/0030547 A1	02-02-2012	Raptis et al.	
	15.	US-	8,050,728 B2	11-01-2011	Al-Ali et al.	
	16.	US-	7,991,448 B2	08-02-2011	Edgar et al.	
	17.	US-	7,914,468 B2	03-29-2011	Shalon et al.	
	18.	US-	2011/0028813 A1	02-03-2011	Watson et al.	
	19.	US-	2011/0028810 A1	02-03-2011	Van Slyke et al.	
	20.	US-	7,843,325 B2	11-30-2010	Otto	
	21.	US-	2010/0228315	09-09-2010	Nielsen	
	22.	US-	2010/0222655 A1	09-02-2010	Starr et al.	
	23.	US-	2010/0217102 A1	08-26-2010	LeBoeuf et al.	
	24.	US-	2010/0185105 A1	07-22-2010	Baldinger	
	25.	US-	2010/0179389	07-15-2010	Moroney et al.	
	26.	US-	7,756,559 B2	07-13-2010	Abreu	
	27.	US-	2010/0172522 A1	07-08-2010	Mooring et al.	
	28.	US-	7,725,147 B2	05-25-2010	Li et al.	
	29.	US-	2010/0100013	04-22-2010	Hu et al.	
	30.	US-	7,695,440 B2	04-13-2010	Kondo et al.	
	31.	US-	2010/0045663	02-25-2010	Chen et al.	
	32.	US-	2010/0004517 A1	01-07-2010	Bryenton et al.	
	33.	US-	7,625,285 B2	12-01-2009	Breving	
	34.	US-	2009/0264711 A1	10-22-2009	Schuler et al.	
	35.	US-	7,583,994 B2	09-01-2009	Scholz	
	36.	US-	2009/0214060 A1	08-27-2009	Chuang et al.	
	37.	US-	2009/0131764 A1	05-21-2009	Lee et al.	
	38.	US-	2009/0131761 A1	05-21-2009	Moroney III et al.	

Examiner Signature		Date Considered	
-----------------------	--	--------------------	--

\*EXAMINER: Initial if reference considered, whether or not citation is in conformance with MPEP 609. Draw line through citation if not in conformance and not considered. Include copy of this form with next communication to applicant.

**INFORMATION DISCLOSURE  
STATEMENT BY APPLICANT**

*(use as many sheets as necessary)*

Sheet **B2** of **B8**

**Complete if Known**

Application Number	14/484,585
Filing Date	September 12, 2014
First Named Inventor	Steven Francis LeBoeuf
Art Unit	2852
Examiner Name	Fuller, Rodney Evan
Attorney Docket Number	9653-7TSCT5

39.	US-	2009/0112071 A1	04-30-2009	LeBoeuf et al.	
40.	US-	2009/0105548 A1	04-23-2009	Bart	
41.	US-	7,519,327 B2	04-14-2009	White	
42.	US-	2009/0093687 A1	04-09-2009	Telfort et al.	
43.	US-	2009/0088611 A1	04-02-2009	Buschmann	
44.	US-	2009/0082994 A1	03-26-2009	Schuler et al.	
45.	US-	2009/0069645 A1	03-12-2009	Nielsen et al.	
46.	US-	7,486,988 B2	02-03-2009	Goodall et al.	
47.	US-	7,483,730 B2	01-27-2009	Diab et al.	
48.	US-	2009/0010461 A1	01-08-2009	Klinghult et al.	
49.	US-	2009/0006457 A1	01-01-2009	Stivoric et al.	
50.	US-	2009/0005662 A1	01-01-2009	Petersen et al.	
51.	US-	7,470,234 B1	12-30-2008	Elhag et al.	
52.	US-	2008/0287752 A1	11-20-2008	Stroetz et al.	
53.	US-	2008/0200774 A1	08-21-2008	Luo	
54.	US-	2008/0171945 A1	07-17-2008	Dotter	
55.	US-	2008/0170600 A1	07-17-2008	Sattler et al.	
56.	US-	2008/0154105 A1	06-26-2008	Lemay	
57.	US-	2008/0154098 A1	06-26-2008	Morris et al.	
58.	US-	2008/0146892 A1	06-19-2008	LeBoeuf et al.	
59.	US-	2008/0146890 A1	06-19-2008	LeBoeuf et al.	
60.	US-	2008/0141301 A1	06-12-2008	Azzaro et al.	
61.	US-	2008/0132798 A1	06-05-2008	Hong et al.	
62.	US-	7,376,451 B2	05-20-2008	Mahony et al.	
63.	US-	2008/0114220 A1	05-15-2008	Banet et al.	
64.	US-	2008/0081963 A1	04-03-2008	Naghavi et al.	
65.	US-	7,341,559 B2	03-11-2008	Schultz et al.	
66.	US-	7,336,982 B2	02-26-2008	Yoo et al.	
67.	US-	2008/0004536 A1	01-03-2008	Baxi et al.	
68.	US-	2007/0270671	11-22-2007	Gal	
69.	US-	2007/0270667 A1	11-22-2007	Coppi et al.	
70.	US-	2007/0265097 A1	11-15-2007	Havukainen	
71.	US-	2007/0233403 A1	10-04-2007	Alwan et al.	
72.	US-	2007/0213020 A1	09-13-2007	Novac	
73.	US-	7,263,396 B2	08-28-2007	Chen et al.	
74.	US-	2007/0197881 A1	08-23-2007	Wolf et al.	
75.	US-	7,252,639 B2	08-07-2007	Kimura et al.	
76.	US-	2007/0165872 A1	07-19-2007	Bridger et al.	
77.	US-	2007/0116314 A1	05-24-2007	Grilliot et al.	
78.	US-	2007/0118054 A1	05-24-2007	Oliver et al.	
79.	US-	2007/0112598 A1	05-17-2007	Heckerman et al.	
80.	US-	2007/0106167 A1	05-10-2007	Kinast	

Examiner Signature		Date Considered	
--------------------	--	-----------------	--

\*EXAMINER: Initial if reference considered, whether or not citation is in conformance with MPEP 609. Draw line through citation if not in conformance and not considered. Include copy of this form with next communication to applicant.

**INFORMATION DISCLOSURE  
STATEMENT BY APPLICANT**

*(use as many sheets as necessary)*

Sheet **B3** of **B8**

**Complete if Known**

Application Number	14/484,585
Filing Date	September 12, 2014
First Named Inventor	Steven Francis LeBoeuf
Art Unit	2852
Examiner Name	Fuller, Rodney Evan
Attorney Docket Number	9653-7TSCT5

81.	US-	2007/0088221 A1	04-19-2007	Stahmann	
82.	US-	2007/0083095 A1	04-12-2007	Rippo et al.	
83.	US-	2007/0083092 A1	04-12-2007	Rippo et al.	
84.	US-	2007/0082789 A1	04-12-2007	Nissila et al.	
85.	US-	2007/0063850 A1	03-22-2007	Devaul et al.	
86.	US-	2007/0060800 A1	03-15-2007	Drinan et al.	
87.	US-	7,175,601 B2	02-13-2007	Verjus et al.	
88.	US-	2007/0027367 A1	02-01-2007	Oliver et al.	
89.	US-	2007/0021206 A1	01-25-2007	Sunnen	
90.	US-	2007/0015992 A1	01-18-2007	Filkins et al.	
91.	US-	2007/0004449 A1	01-04-2007	Sham	
92.	US-	2007/0004969 A1	01-04-2007	Kong et al.	
93.	US-	2006/0292533 A1	12-28-2006	Selod	
94.	US-	2006/0251334 A1	11-09-2006	Oba et al.	
95.	US-	2006/0246342 A1	11-02-2006	MacPhee	
96.	US-	2006/0240558 A1	10-26-2006	Zhao	
97.	US-	2006/0224059 A1	10-05-2006	Swedlow et al.	
98.	US-	2006/0210058 A1	09-21-2006	Kock et al.	
99.	US-	2006/0211922 A1	09-21-2006	Al-Ali et al.	
100.	US-	2006/0205083 A1	09-14-2006	Zhao	
101.	US-	2006/0202816 A1	09-14-2006	Crump et al.	
102.	US-	7,088,234 B2	08-08-2006	Naito et al.	
103.	US-	2006/0142665 A1	06-29-2006	Garay et al.	
104.	US-	2006/0123885	06-15-2006	Yates et al.	
105.	US-	7,054,674 B2	05-30-2006	Cane et al.	
106.	US-	7,043,287 B2	05-09-2006	Khalil et al.	
107.	US-	7,041,062 B2	05-09-2006	Friedrichs et al.	
108.	US-	2006/0084878 A1	04-20-2006	Banet et al.	
109.	US-	7,024,369 B2	04-04-2006	Brown et al.	
110.	US-	7,018,338 B2	03-28-2006	Vetter et al.	
111.	US-	2006/0064037	03-23-2006	Shalon et al.	
112.	US-	2005/0258816 A1	11-24-2005	Zen et al.	
113.	US-	2005/0259811 A1	11-24-2005	Kimm et al.	
114.	US-	2005/0240087 A1	10-27-2005	Keenan et al.	
115.	US-	2005/0228244 A1	10-13-2005	Banet	
116.	US-	6,953,435 B2	10-11-2005	Kondo et al.	
117.	US-	2005/0222903 A1	10-06-2005	Buchheit et al.	
118.	US-	2005/0222487 A1	10-06-2005	Miller et al.	
119.	US-	2005/0203349	09-15-2005	Nanikashvili	
120.	US-	2005/0196009 A1	09-08-2005	Boesen	
121.	US-	6,941,239 B2	09-06-2005	Unuma et al.	
122.	US-	2005/0192515 A1	09-01-2005	Givens et al.	

Examiner Signature		Date Considered	
--------------------	--	-----------------	--

\*EXAMINER: Initial if reference considered, whether or not citation is in conformance with MPEP 609. Draw line through citation if not in conformance and not considered. Include copy of this form with next communication to applicant.

**INFORMATION DISCLOSURE  
STATEMENT BY APPLICANT**

(use as many sheets as necessary)

Sheet **B4** of **B8**

**Complete if Known**

Application Number	14/484,585
Filing Date	September 12, 2014
First Named Inventor	Steven Francis LeBoeuf
Art Unit	2852
Examiner Name	Fuller, Rodney Evan
Attorney Docket Number	9653-7TSC5

123.	US-	2005/0187448 A1	08-25-2005	Petersen et al.	
124.	US-	2005/0154264 A1	07-14-2005	Lecompte et al.	
125.	US-	2005/0148883 A1	07-07-2005	Boesen	
126.	US-	2005/0119833	06-02-2005	Nanikashvili	
127.	US-	2005/0116820	06-02-2005	Goldreich	
128.	US-	2005/0113703 A1	05-26-2005	Farringdon et al.	
129.	US-	2005/0113656 A1	05-26-2005	Chance	
130.	US-	2005/0113167 A1	05-25-2005	Buchner et al.	
131.	US-	6,893,396	05-17-2005	Schulze et al.	
132.	US-	2005/0059870 A1	03-17-2005	Aceti	
133.	US-	2005/0058456 A1	03-17-2005	Yoo	
134.	US-	2005/0043630 A1	02-24-2005	Honeyager et al.	
135.	US-	2005/0043630 A1	02-24-2005	Buchert	
136.	US-	2005/0038349 A1	02-17-2005	Choi et al.	
137.	US-	2005/0027216 A1	02-03-2005	Guillemaud et al.	
138.	US-	2005/0004458 A1	01-06-2005	Kanayama et al.	
139.	US-	2004/0242976 A1	12-02-2004	Abreu	
140.	US-	2004/0228494 A1	11-18-2004	Smith	
141.	US-	2004/0219056 A1	11-04-2004	Tribelsky et al.	
142.	US-	2004/0220488 A1	11-04-2004	Vyshedskiy et al.	
143.	US-	2004/0186390 A1	09-23-2004	Ross et al.	
144.	US-	2004/0138578 A1	07-15-2004	Pineda et al.	
145.	US-	2004/0135571 A1	07-15-2004	Uutela et al.	
146.	US-	2004/0133123 A1	07-08-2004	Leonhardt et al.	
147.	US-	6,760,610 B2	07-06-2004	Tschupp et al.	
148.	US-	2004/0120844 A1	06-24-2004	Tribelsky et al.	
149.	US-	2004/0122702 A1	06-24-2004	Sabol et al.	
150.	US-	2004/0122294 A1	06-24-2004	Hatlestad et al.	
151.	US-	2004/0117204 A1	06-17-2004	Mazar et al.	
152.	US-	2004/0103146 A1	05-27-2004	Park	
153.	US-	2004/0075677 A1	04-22-2004	Loyall et al.	
154.	US-	2004/0077934 A1	04-22-2004	Massad	
155.	US-	2004/0034289 A1	02-19-2004	Teller et al.	
156.	US-	6,694,180 B1	02-17-2004	Boesen	
157.	US-	2004/0022700 A1	02-05-2004	Kim et al.	
158.	US-	2004/0004547 A1	01-08-2004	Appelt et al.	
159.	US-	6,656,116 B2	12-02-2003	Kim et al.	
160.	US-	2003/0220584 A1	11-27-2003	Honeyager et al.	
161.	US-	6,647,378 B2	11-11-2003	Kindo	
162.	US-	6,631,196 B1	10-07-2003	Taenzer et al.	
163.	US-	2003/0181795 A1	09-25-2003	Suzuki et al.	
164.	US-	6,605,038	08-12-2003	Teller et al.	

Examiner Signature		Date Considered	
--------------------	--	-----------------	--

\*EXAMINER: Initial if reference considered, whether or not citation is in conformance with MPEP 609. Draw line through citation if not in conformance and not considered. Include copy of this form with next communication to applicant.

<b>INFORMATION DISCLOSURE STATEMENT BY APPLICANT</b>			<b>Complete if Known</b>	
			Application Number	14/484,585
			Filing Date	September 12, 2014
			First Named Inventor	Steven Francis LeBoeuf
			Art Unit	2852
			Examiner Name	Fuller, Rodney Evan
Sheet <b>B5</b>	of	<b>B8</b>	Attorney Docket Number	9653-7TSCT5

165.	US-	6,571,117	05-27-2003	Marbach	
166.	US-	6,569,094 B2	05-27-2003	Suzuki et al.	
167.	US-	2003/0083583 A1	05-01-2003	Kovtun et al.	
168.	US-	6,556,852	04-29-2003	Schulze et al.	
169.	US-	2003/0064712 A1	04-03-2003	Gaston et al.	
170.	US-	6,534,012	03-18-2003	Hazen et al.	
171.	US-	2003/0050563 A1	03-13-2003	Suribhotla et al.	
172.	US-	6,527,711	03-04-2003	Stivoric et al.	
173.	US-	6,514,278	02-04-2003	Hibst et al.	
174.	US-	2003/0007631 A1	01-09-2003	Bolognesi et al.	
175.	US-	2003/0002705 A1	01-02-2003	Boesen	
176.	US-	2002/0186137 A1	12-12-2002	Skardon	
177.	US-	6,470,893	10-29-2002	Boesen	
178.	US-	2002/0156654	10-24-2002	Roe et al.	
179.	US-	2002/0143242 A1	10-03-2002	Nemirovski	
180.	US-	6,458,080 B1	10-01-2002	Brown et al.	
181.	US-	6,454,718	09-24-2002	Cliff	
182.	US-	6,444,474	09-03-2002	Thomas et al.	
183.	US-	6,443,890	09-03-2002	Schulze et al.	
184.	US-	6,361,660	03-26-2002	Goldstein	
185.	US-	6,332,868	12-25-2001	Sato et al.	
186.	US-	2001/0049471 A1	12-06-2001	Suzuki et al.	
187.	US-	6,289,230	09-11-2001	Chaiken et al.	
188.	US-	6,285,816	09-04-2001	Anderson et al.	
189.	US-	6,283,915	09-04-2001	Nolan et al.	
190.	US-	6,231,519 B1	05-15-2001	Blants et al.	
191.	US-	6,198,394 B1	03-06-2001	Jacobsen et al.	
192.	US-	6,186,145 B1	02-13-2001	Brown	
193.	US-	6,067,006	05-23-2000	O'Brien	
194.	US-	6,045,511	04-04-2000	Ott et al.	
195.	US-	6,013,007	01-11-2000	Root et al.	
196.	US-	6,004,274	12-21-1999	Aceti et al.	
197.	US-	5,995,858	11-30-1999	Kinast	
198.	US-	5,971,931	10-26-1999	Raff	
199.	US-	5,938,593	08-17-1999	Quellette	
200.	US-	5,853,005	12-29-1998	Scanlon	
201.	US-	5,807,114	09-15-1998	Hodges et al.	
202.	US-	5,779,631	07-04-1998	Chance	
203.	US-	5,743,260	04-28-1998	Chung et al.	
204.	US-	5,711,308	01-27-1998	Singer	
205.	US-	5,697,374	12-16-1997	Odagiri et al.	
206.	US-	5,673,692	10-07-1997	Schulze et al.	

Examiner Signature		Date Considered	
--------------------	--	-----------------	--

\*EXAMINER: Initial if reference considered, whether or not citation is in conformance with MPEP 609. Draw line through citation if not in conformance and not considered. Include copy of this form with next communication to applicant.

**INFORMATION DISCLOSURE  
STATEMENT BY APPLICANT**

*(use as many sheets as necessary)*

Sheet **B6** of **B8**

**Complete if Known**

Application Number	14/484,585
Filing Date	September 12, 2014
First Named Inventor	Steven Francis LeBoeuf
Art Unit	2852
Examiner Name	Fuller, Rodney Evan
Attorney Docket Number	9653-7TSCT5

207.	US-	5,662,117	09-02-1997	Bittman	
208.	US-	5,499,301	03-12-1996	Sudo et al.	
209.	US-	5,492,129	02-20-1996	Greenberger	
210.	US-	5,482,036	01-09-1996	Diab et al.	
211.	US-	5,377,100	12-27-1994	Pope et al.	
212.	US-	5,348,002	09-20-1994	Caro	
213.	US-	5,143,078	09-01-1992	Mather et al.	
214.	US-	5,079,421	01-07-1992	Knudson et al.	
215.	US-	5,022,970	06-11-1991	Cook et al.	
216.	US-	4,957,109	09-18-1990	Groeger et al.	
217.	US-	4,928,704	05-29-1990	Hardt	
218.	US-	4,655,225	04-07-1987	Dahne et al.	
219.	US-	4,592,807	06-03-1986	Switzer	
220.	US-	4,541,905	09-17-1985	Kuwana et al.	
221.	US-	4,521,499	06-04-1985	Switzer	
222.	US-	4,491,760	01-01-1985	Linwill	
223.	US-	4,438,772	03-27-1984	Slavin	
224.	US-	4,521,499	05-19-1983	Switzer	
225.	US-	4,240,882	12-23-1980	Ang et al.	
226.	US-	3,595,219	07-27-1971	Friedlander et al.	

**FOREIGN PATENT DOCUMENTS**

Examiner Initials*	Cite No.	Foreign Patent Document	Publication Date MM-DD-YYYY	Name of Patentee or Applicant of Cited Document	Pages, Columns, Lines, Where Relevant Passages or Relevant Figures Appear	T
		Country Code, Number, Kind Code (if known)				
	227.	WO 2008/141306 A2	11-20-2008	Sigmed Inc.		
	228.	WO 2005/020121 A1	03-03-2005	Lee, Min-Hwa		
	229.	WO 2000/047108 A1	08-17-2000	Medoc Ltd.		
	230.	GB 2 411 719 A	09-07-2005	Nova Design LTD		
	231.	JP 20030159221	06-03-2003	Shiseido Co., Ltd.		T
	232.	JP 2004-283523	10-14-2004	Yoshisisa et al.		T
	233.	JP 2007-044203	02-22-2007	Toshiba Corp. et al.		T
	234.	JP 2010-526646	08-05-2010	Sigmed Inc.		T

Examiner Signature		Date Considered	
--------------------	--	-----------------	--

\*EXAMINER: Initial if reference considered, whether or not citation is in conformance with MPEP 609. Draw line through citation if not in conformance and not considered. Include copy of this form with next communication to applicant.



<b>INFORMATION DISCLOSURE STATEMENT BY APPLICANT</b>		<i>Complete if Known</i>		
		Application Number	14/484,585	
		Filing Date	September 12, 2014	
		First Named Inventor	Steven Francis LeBoeuf	
		Art Unit	2852	
		Examiner Name	Fuller, Rodney Evan	
Sheet <b>B7</b>	of	<b>B8</b>	Attorney Docket Number	9653-7TSCT5

NON PATENT LITERATURE DOCUMENTS			
Examiner Initials*	Cite No.	Include name of the author (in CAPITAL LETTERS), title of the article (when appropriate), title of the item (book, magazine, journal, serial, symposium, catalog, etc.), date, page(s), volume-issue number(s), publisher, city and/or country where published	T
	235.	"U.S. Army Fitness Training Handbook" by the Department of the Army, 2003, The Lyons Press. pg. 17.	
	236.	"Warfighter Physiological and Environmental Monitoring: A Study for the U.S. Army Research Institute in Environmental Medicine and the Soldier Systems Center", Massachusetts Institute of Technology Lincoln Laboratory, Final Report, November, 1st 2004, prepared for the U.S. Army under Air Force Contract F19628-00-C-0002; approved for public release.	
	237.	Anpo et al. "Photocatalytic Reduction of CO <sub>2</sub> With H <sub>2</sub> O on Titanium Oxides Anchored within Micropores of Zeolites: Effects of the Structure of the Active Sites and the Addition of Pt" <u>J. Phys. Chem. B</u> , 101:2632-2636 (1997)	
	238.	Bârsan et al. "Understanding the fundamental principles of metal oxide based gas sensors; the example of CO sensing with SnO <sub>2</sub> sensors in the presence of humidity" <u>Journal of Physics: Condensed Matter</u> 15:R813-R839 (2003)	
	239.	Bott "Electrochemistry of Semiconductors" <u>Current Separations</u> 17(3):87-91 (1998)	
	240.	Colligan, M. J. et al. in "The psychological effects of indoor air pollution", Bulletin of the New York Academy of Medicine, Vol. 57, No. 10, December 1981, pg. 1014-1026	
	241.	de Paula Santos, U. et al, in "Effects of air pollution on blood pressure and heart rate variability: a panel study of vehicular traffic controllers in the city of Sao Paulo, Brazil", <u>European Heart Journal</u> (2005) 26, 193-200	
	242.	Ebert, T et al., "Influence of Hydration Status on Thermoregulation and Cycling Hill Climbing," <u>Med. Sci. Sport Exerc.</u> Vol. 39, No. 2, pp. 323-329, 2007	
	243.	European Search Report corresponding to European Application No. 07862660.3 dated 04-25-12; 7 pages	
	244.	Falkner et al, "Cardiovascular response to mental stress in normal adolescents with hypertensive parents. Hemodynamics and mental stress in adolescents," <u>Hypertension</u> 1979, 1:23-30	
	245.	Fleming et al., "A Comparison of Signal Processing Techniques for the Extraction of Breathing Rate from the Photoplethysmogram," <u>World Academy of Science, Engineering and Technology</u> , Vol. 30, October 2007, pp. 276-280	
	246.	Geladas et al., "Effect of cold air inhalation on core temperature in exercising subjects under stress," <u>The American Physiological Society</u> , pp. 2381-2387, 1988	
	247.	Gold, D.R. et al. in "Ambient Pollution and Heart Rate Variability", <u>Circulation</u> 2000, 101:1267-1273	
	248.	International Search Report corresponding to International Patent Application No. PCT/US2012/046446, Date of Mailing: January 14, 2013, 3 pages	
	249.	International Search Report and Written Opinion of the International Searching Authority, corresponding to PCT/US2012/0948079, mailed October 9, 2012.	
	250.	International Search Report and Written Opinion of the International Searching Authority, corresponding to PCT/US2007/025114, mailed May 13, 2008.	

Examiner Signature		Date Considered	
--------------------	--	-----------------	--

\*EXAMINER: Initial if reference considered, whether or not citation is in conformance with MPEP 609. Draw line through citation if not in conformance and not considered. Include copy of this form with next communication to applicant.

<b>INFORMATION DISCLOSURE STATEMENT BY APPLICANT</b>		<i>Complete if Known</i>	
		Application Number	14/484,585
		Filing Date	September 12, 2014
		First Named Inventor	Steven Francis LeBoeuf
		Art Unit	2852
		Examiner Name	Fuller, Rodney Evan
(use as many sheets as necessary)	Attorney Docket Number	9653-7TSCT5	
Sheet	<b>B8</b>	of	<b>B8</b>

	251.	International Search Report Corresponding to International Application No. PCT/US2012/022634, Date of Mailing: August 22, 2012, 9 pages	
	252.	Maomao et al., "Mobile Context-Aware Game for the Next Generation," 2 <sup>nd</sup> International Conference on Application and Development of Computer Games ADCOG 2003, pg. 78-81	
	253.	Martins et al. "Zinc oxide as an ozone sensor" <u>Journal of Applied Physics</u> 96(3):1398-1408 (2004)	
	254.	Maughan, R.J., "Impact of mild dehydration on wellness and on exercise performance," <u>European Journal of Clinical Nutrition</u> , 57, Suppl. 2, pp. S19-S23, 2003	
	255.	Maughan et al., "Exercise, Heat, Hydration and the Brain," <u>Journal of the American College of Nutrition</u> , Vol. 26, No. 5, pp. 604S-612S, 2007	
	256.	Mostardi, R., et al., "The effect of increased body temperature due to exercise on the heart rate and the maximal aerobic power," <u>Europ. J. Appl. Physiol</u> , 33, pp. 237-245, 1974	
	257.	Nakajima et al., "Monitoring of heart and respiratory rates by photoplethysmography using a digital filtering technique," <u>Med. Eng. Phys.</u> , Vol. 18, No. 5, July 1996, pp. 365-372	
	258.	Notification of Transmittal of the International Search Report and Written Opinion of the International Search Authority issued July 30, 2010 by the Korean Intellectual Property Office for corresponding International Application No. PCT/US2010/021936	
	259.	Notification of Transmittal of the International Search Report and the Written Opinion of the International Search Authority issued September 16, 2010 by the Korean Intellectual Property Office for corresponding International Application No. PCT/US2010/024922	
	260.	Notification of Transmittal of the International Search Report and the Written Opinion of the International Search Authority issued September 27, 2010 by the Korean Intellectual Property Office for corresponding International Application No. PCT/US2010/025216	
	261.	Saladin et al. "Photosynthesis of CH <sub>4</sub> at a TiO <sub>2</sub> Surface from Gaseous H <sub>2</sub> O and CO <sub>2</sub> " <u>J. Chem. Soc., Chem. Commun.</u> 533-534 (1995)	
	262.	Shorten et al., "Acute effect of environmental temperature during exercise on subsequent energy intake in active men," <u>Am. J Clin. Nutr.</u> 90, pp. 1215-21, 2009	
	263.	Skubal et al. "Detection and identification of gaseous organics using a TiO <sub>2</sub> sensor" <u>Journal of Photochemistry and Photobiology A: Chemistry</u> 148:103-108 (2002)	
	264.	Skubal et al. "Monitoring the Electrical Response of Photoinduced Organic Oxidation on TiO <sub>2</sub> Surfaces" Manuscript submitted October 2000 to SPIE Intl. Symposium on Environment & Industrial Sensing, Boston, MA, November 5-8, 2000, sponsored by SPIE, 10 pp.	
	265.	Thompson, M.W., "Cardiovascular drift and critical core temperature: factors limiting endurance performance in the heat?" <u>J. Exerc. Sci. Fit</u> , Vol. 4, No. 1, pp. 15-24, 2006	
	266.	Zhang et al. "Development of Chemical Oxygen Demand On-Line Monitoring System Based on a Photoelectrochemical Degradation Principle" <u>Environ. Sci. Technol.</u> , 40(7):2363 -2368 (2006)	

Examiner Signature		Date Considered	
--------------------	--	-----------------	--

\*EXAMINER: Initial if reference considered, whether or not citation is in conformance with MPEP 609. Draw line through citation if not in conformance and not considered. Include copy of this form with next communication to applicant.



Espacenet

## Bibliographic data: WO2008141306 (A2) — 2008-11-20

### NON-INVASIVE CHARACTERIZATION OF A PHYSIOLOGICAL PARAMETER

No documents available for this priority number.

**Inventor(s):** TZYY-PING JUNG [US]; HYUN-JIN PARK [US] ± (TZYY-PING, JUNG, ; HYUN-JIN, PARK)

**Applicant(s):** SIGMED INC [US]; TZYY-PING JUNG [US]; HYUN-JIN PARK [US] ± (SIGMED, INC, ; TZYY-PING, JUNG, ; HYUN-JIN, PARK)

**Classification:** - international: **A61B5/145**  
- cooperative: **A61B5/14532**; A61B2560/0242; A61B5/053

**Application number:** WO2008US63469 20080512

**Priority number (s):** US20070917610P 20070511

**Also published as:** WO2008141306 (A3) US2010324398 (A1) JP2010526646 (A) EP2152895 (A2)

### Abstract of WO2008141306 (A2)

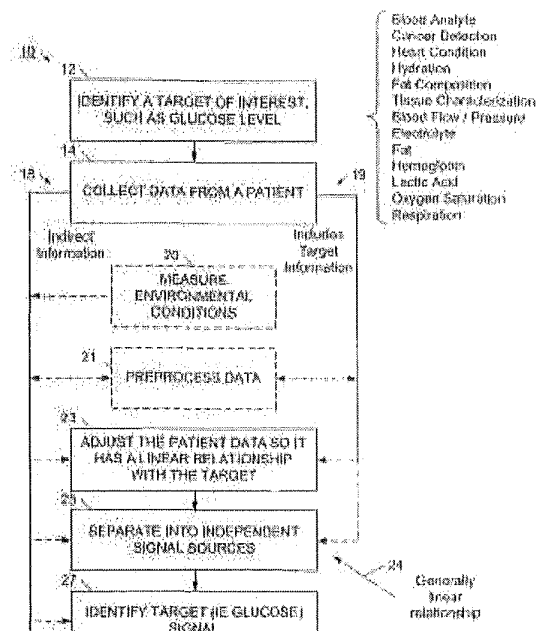

The present invention provides a method and device for characterizing a physiological parameter. The method, in one application, uses one or more non-invasive sensors to collect patient data, and

may also collect data on environmental conditions. At least some of the patient data has a direct relationship with the physiological parameter, that is, a change in the physiological parameter is reflected in the data set, although the magnitude of the physiological parameter may be masked by noise, interference, or other environmental or patient influences. The direct patient data preferably has a generally linear relationship with the physiological parameter, and if not, the patient data is linearized according to an algorithm, table, or other adjustment process. These linearizing processes may be predefined, and may adaptively learn or adjust. A blind signal source process is applied to the linearized data to generate separated signals, and the signal associated with the physiological parameter is identified. The identified signal is scaled or further processed, and the characterization result is presented. Although the method and device are described for use with a human, they may be advantageously used on animals.

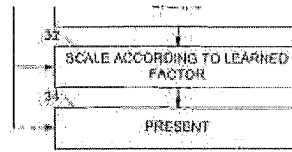

FIG. 1

(12) INTERNATIONAL APPLICATION PUBLISHED UNDER THE PATENT COOPERATION TREATY (PCT)

(19) World Intellectual Property Organization  
International Bureau



(43) International Publication Date  
20 November 2008 (20.11.2008)

PCT

(10) International Publication Number  
WO 2008/141306 A2

- (51) International Patent Classification:  
A61B 5/145 (2006.01)
- (21) International Application Number:  
PCT/US2008/063469
- (22) International Filing Date: 12 May 2008 (12.05.2008)
- (25) Filing Language: English
- (26) Publication Language: English
- (30) Priority Data:  
60/917,610 11 May 2007 (11.05.2007) US
- (71) Applicant (for all designated States except US):  
SIGMED, INC. [US/US]; 3830 Valley Center Dr.,  
Suite 705-632, San Diego, CA 92130 (US).
- (72) Inventors; and
- (75) Inventors/Applicants (for US only): T'ZYY-PING, Jung  
[US/US]; 12235 Caminito Del Mar Sands, Garden Grove,  
CA (US). HYUN-JIN, Park [KR/US]; 3830 Valley Center  
Dr., Suite 705-632, San Diego, CA 92130 (US).
- (74) Agent: KOLEGRAFF, William, J.; Law Office Of Bill  
Kolegraff, 3119 Tumberry Way, Jamul, CA 91935 (US).

(81) Designated States (unless otherwise indicated, for every kind of national protection available): AE, AG, AL, AM, AO, AT, AU, AZ, BA, BB, BG, BH, BR, BW, BY, BZ, CA, CH, CN, CO, CR, CU, CZ, DE, DK, DM, DO, DZ, EC, EE, EG, ES, FI, GB, GD, GE, GH, GM, GT, HN, HR, HU, ID, IL, IN, IS, JP, KE, KG, KM, KN, KP, KR, KZ, LA, LC, LK, LR, LS, LT, LU, LY, MA, MD, ME, MG, MK, MN, MW, MX, MY, MZ, NA, NG, NI, NO, NZ, OM, PG, PH, PL, PT, RO, RS, RU, SC, SD, SE, SG, SK, SL, SM, SV, SY, TJ, TM, TN, TR, TT, TZ, UA, UG, US, UZ, VC, VN, ZA, ZM, ZW.

(84) Designated States (unless otherwise indicated, for every kind of regional protection available): ARIPO (BW, GH, GM, KE, LS, MW, MZ, NA, SD, SL, SZ, TZ, UG, ZM, ZW), Eurasian (AM, AZ, BY, KG, KZ, MD, RU, TJ, TM), European (AT, BE, BG, CH, CY, CZ, DE, DK, EE, ES, FI, FR, GB, GR, HR, HU, IE, IS, IT, LT, LU, LV, MC, MT, NL, NO, PL, PT, RO, SE, SI, SK, TR), OAPI (BF, BJ, CF, CG, CI, CM, GA, GN, GQ, GW, ML, MR, NE, SN, TD, TG).

[Continued on next page]

(54) Title: NON-INVASIVE CHARACTERIZATION OF A PHYSIOLOGICAL PARAMETER

WO 2008/141306 A2

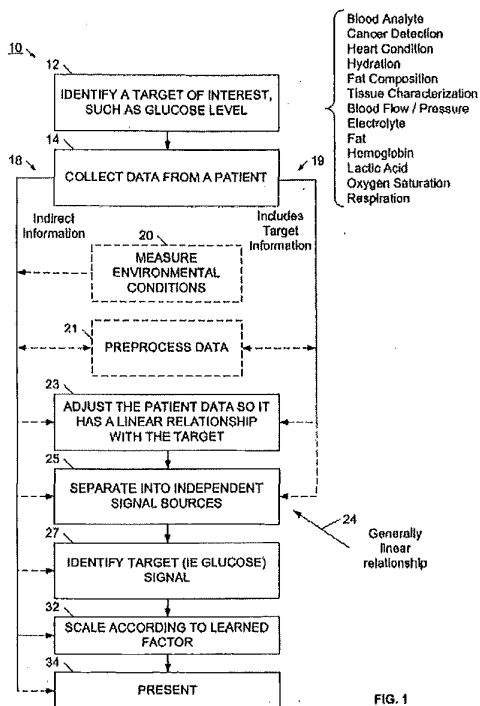

FIG. 1

(57) Abstract: The present invention provides a method and device for characterizing a physiological parameter. The method, in one application, uses one or more non-invasive sensors to collect patient data, and may also collect data on environmental conditions. At least some of the patient data has a direct relationship with the physiological parameter, that is, a change in the physiological parameter is reflected in the data set, although the magnitude of the physiological parameter may be masked by noise, interference, or other environmental or patient influences. The direct patient data preferably has a generally linear relationship with the physiological parameter, and if not, the patient data is linearized according to an algorithm, table, or other adjustment process. These linearizing processes may be predefined, and may adaptively learn or adjust. A blind signal source process is applied to the linearized data to generate separated signals, and the signal associated with the physiological parameter is identified. The identified signal is scaled or further processed, and the characterization result is presented. Although the method and device are described for use with a human, they may be advantageously used on animals.



**Declaration under Rule 4.17:**

— *of inventorship (Rule 4.17(iv))*

**Published:**

— *without international search report and to be republished upon receipt of that report*

**NON-INVASIVE CHARACTERIZATION OF A PHYSIOLOGICAL PARAMETER**Field of the Invention

[0001] Embodiments of the present invention relate to non-invasive devices and methods for characterizing a physiological parameter in a living being, such as a human. In one example, the present invention provides a device and process for estimating a blood analyte concentration level, such as a glucose level.

Description of the Related Art

[0002] Diabetes is a chronic disease that has no cure. About 20.8 million people (7 percent of the population) of people in the United States were estimated to have diabetes in 2005. As the sixth leading cause of death by disease in 2000, diabetes is costing the U.S. health care system an estimated \$132 billion annually. *See, National Diabetes Information Clearinghouse, NIH Publication No. 04-3892, November 2003.* More serious than the economic costs associated with diabetes is the decrease in the quality of life, serious health complications/consequences, and deaths associated with diabetes.

[0003] Diabetes is a group of diseases characterized by high blood glucose levels, which result from defects in insulin production, insulin action, or both. Carbohydrates from food are converted into monosaccharide glucose, which triggers beta cells to release insulin into the blood. Insulin allows for glucose absorption by other cells for energy, molecular conversion or storage. Insulin exhibits control over the conversion of glucose to glycogen for storage in the liver and in muscle cells. However, glucose may be improperly regulated if insulin is produced in insufficient amounts, if insulin is defective or if cells do not properly respond to insulin. This may result in high blood glucose levels, poor protein synthesis and other metabolic derangements.

[0004] Hyperglycemia in the diabetic is strongly suspected of being responsible for the long-term effects of diabetes which include cardiovascular disease, arteriosclerosis, blindness, cerebrovascular disease including stroke, hypertension, kidney failure, peripheral vascular disease and premature death. Severe hypoglycemia has similar drastic consequences. In a normal person, the blood glucose level may vary between 60 and 130 milligrams per

deciliter, a variance exceeding 100%; whereas, in a diabetic, the levels may vary from time to time from 40 to 500 milligrams per deciliter, a variance of 1150% for hyperglycemia. For hypoglycemia, 60 milligrams per deciliter indicates that treatment is necessary; the glucose may reach a dangerous level of 20 milligrams per deciliter. These large swings of glucose levels must be avoided to prevent the symptoms and complications of the disease. Ideally, the diabetic could conveniently monitor his blood glucose level, and then vary his or her caloric intake, diet and insulin to control the glucose level and thereby avoid the swings. For effective control, frequent blood glucose monitoring is necessary.

[0005] Currently, the preferred glucose monitoring technique includes blood sampling. Diabetics prick their epidermis with a needle or lance, usually in the finger, draws a drop of blood, and absorbs the blood on a chemically treated strip of paper. They can then read the glucose level by placing the strip in a glucometer (a spectrophotometer which reads glucose concentrations); or they can compare the color change of the strip with a calibrated color chart. Other methods include measuring the electrical resistance of the strip with a glucometer which is an ohmmeter calibrated in milligrams per deciliter. For effective control, some diabetics must utilize a finger prick four or more times a day.

[0006] However, blood extractions for such tests often become a real burden to the diabetic, so they fail to regularly monitor their glucose levels. Diabetic patients may be less likely to routinely monitor their glucose levels due to the invasiveness of the procedure, as well as due to the pain associated with continually pricking their finger. In addition, the chemical reagents used in the tests are quite expensive, particularly in view of the large number of tests required. Accordingly, diabetics may fail to adequately monitor their glucose levels.

[0007] Numerous less burdensome or less invasive approaches have been attempted to monitor levels of analytes such as glucose within the body. To date, none have been successful. For example, these approaches have proven not to be accurate enough, or have been so sensitive to environmental conditions that readings are not meaningful. In addition, those devices that produce reasonable data in human subjects typically require substantial calibration data, often involving multiple calibrations (e.g., >20 blood glucose values) over several days. Limitations aside, non-invasive monitoring of physiological



parameters, such as non-invasive glucose monitoring, remains the “holy grail” of diabetes management as well as cardiovascular diseases and other conditions that can be monitored or detected using one or more physiological parameters. For example, optical techniques to monitor physiological parameters such as blood analytes are truly noninvasive. The tissue is irradiated, the absorbed or scattered radiation is analyzed, and the information is processed, to provide a measure proportional to the concentration of the blood analyte in the dermal tissue. These techniques include near to far infrared and Raman spectroscopy, polarimetry, light scattering or absorption, and photoacoustic spectroscopy.

[0008] One non-invasive approach that has received much attention involves dielectric measurements, such as tissue (skin) electrical impedance measurements. In this approach, the complex impedance is measured over a broad (Hz to MHz to GHz to THz) frequency range. Impedance spectroscopy measures changes in the dielectric properties of the tissue induced by analyte variation. At lower frequencies the response is believed to result from ion rotation in water. This rotation can be affected by both electrolyte (such as NaCl) concentration and substances which alter the solvent viscosity (such as glucose or changes in tissue hydration). At higher frequencies the response is primarily attributed to changes in the dipole moment of the electrolyte constituents. However, the low specificity of pure impedance measurements makes this approach unlikely to succeed. To overcome these difficulties, data are usually obtained over a broad range of frequencies (so-called impedance spectroscopy) and often analyzed by complex statistical algorithms including partial least squares, principal component analysis and neural net analysis.

[0009] Non-invasive measurement of skin impedance is described in the literature, for example, in U.S. Pat. Nos. 5,890,489 and 6,517,482; and international patent application No. PCT/US 98/02037 to determine the level of a subject's blood glucose. Impedance based technology has been used for medical purposes since the early 1920's, but it was not until the last few decades that new instruments and methods have become available for various clinical applications – e.g. cardiopulmonary tomography (Metherall et al., *Nature* 1996; 380: 509-512), skin and tissue hydration (see, e.g., PCT App. No. WO 05/018432 and WO 06/029034, Tagami et al., *Invest Dermatol* 1980; 75:500-507), detection of dental decay (Longbottom et al., *Nat Med* 1996, 2:235-237), or of neoplasia (Brown et al., *Lancet* 2000, 355-892-895;

Åberg et al., IEEE Trans Biomed Eng 2004, 51:2097–2102; Åberg et al., Skin Res Technol, 2005, 11:281–286; Emtestam et al., Skin Res Technol 2007, 13:73-78; Hope & Iles, Breast Cancer Res, 2004: 6(2) 69-74) and various types of pathological findings in the skin (see., e.g., Emtestam & Nyrén, Am J Contact Dermatitis 1997, 8:202–206; Hagströmer et al., Skin Pharmacol Appl Skin Physiol 2001, 14:27-33; Nicander et al., Br J Dermatol 1996, 134:221–228; Emtestam et al., Dermatology 1998, 197:313–316, Nicander et al., Skin Res Technol 1997, 3:121–12510), each incorporated herein by reference. Investigations of the dielectric properties of analytes using electromagnetic waves allow one to obtain valuable information on the real-time detection and control of blood analytes. These investigations are also of interest for other applications (see also, e.g., provisional U.S. Pat. App. No. 2006/0025664, Siegel, P.H., IEEE Trans. Microwave Theory and Techniques, 2004; 52(10): 2438- 2447; Huo et. al., IEEE Trans. Biomed. Eng. 2004; 51(7): 1089- 1094 for RF signals in the micrometer-wave, millimeter/terahertz range).

[0010] Therefore, there is a need for a non-invasive but reliable method and apparatus for measuring or characterizing a physiological parameter, such as the concentration of analyte (e.g., glucose) in the body of a mammal.

#### Summary of the Invention

[0011] The present invention provides a method and device for characterizing a physiological parameter. The method, in one application, uses one or more non-invasive sensors to collect patient data, and may also collect data on environmental conditions. At least some of the patient data has a direct relationship with the physiological parameter, that is, a change in the physiological parameter is reflected in the data set, although the magnitude of the physiological parameter may be masked by noise, interference, or other environmental or patient influences. The direct patient data preferably has a generally linear relationship with the physiological parameter, and if not, the patient data is linearized according to an algorithm, table, or other adjustment process. These linearizing processes may be predefined, and may adaptively learn or adjust. A blind signal source process is applied to the linearized data to generate separated signals, and the signal associated with the physiological parameter is identified. The identified signal is scaled or further processed, and the characterization

result is presented. Although the method and device are described for use with a human, they may be advantageously used on animals.

[0012] In one example, the present invention provides a glucose monitoring device and method. The glucose monitor non-invasively collects a first set of data that has a direct relationship with the glucose level. The first set of data may be, for example, RF impedance data or infrared data, although many other types of data may be used. The glucose monitor also collects some other data from the patient or from the environment, and uses that data to more effectively process the first set of data. The other data may be, for example, skin temperature, skin humidity, pressure between the non-invasive sensor and the skin, or room temperature. The first set of data may be processed to reduce noise, for example, by processing through a band pass filter, and then linearized according to a predefined algorithm or table. In some examples the linearization process may learn or be otherwise adaptive. The linearized data is passed to an independent component analysis process, where the glucose signal is identified. The glucose signal is then scaled, for example, according to the other data, and presented to the patient as the current glucose level. In one example, the glucose device is a portable and battery powered device. In another example, the glucose monitor is an instrument for use in an office or hospital setting.

[0013] Advantageously, the new characterization method and device are relatively insensitive to fluctuating patient and environment conditions. This enables the method and process to more accurately characterize a physiological parameter, and to allow robust characterization in a much wider range of applications. In some applications, the method and device enable fully non-invasive measurements, allowing patients to avoid pain and dread. For example, a glucose monitor using this method is fully non-invasive, avoiding the pain of the needle prick and the mess of the resulting blood. And since the glucose monitor is relatively insensitive to patient or environmental conditions, the diabetic may confidently use the glucose monitor in a wide range of environments. For example, the glucose monitor may provide a good reading irrespective of whether the patient is cold, warm, resting, active, in a warm room, in a cold room, in a place with high humidity, in a dry place, measuring in the morning, or measuring later in the day.

### Brief Description of the Drawings

[0014] Figure 1 is a flowchart illustrating a process of characterizing a target physiological parameter in accordance with the present invention.

[0015] Figure 2 is a flowchart illustrating a process of characterizing a target physiological parameter in accordance with the present invention.

[0016] Figure 3 is a flowchart illustrating a process of estimating blood analyte concentration levels in accordance with the present invention.

[0017] Figure 4 is a block diagram illustrating components of a device for estimating blood analyte concentration levels in accordance with the present invention.

[0018] Figure 5 is a block diagram illustrating sub-components of the calculation component of Figure 4.

[0019] Figure 6 is a flowchart illustrating a process of characterizing glucose levels in a human in accordance with the present invention.

[0020] Figures 7, 8, and 9 are graphs illustrating data and results from an example using a process of characterizing glucose in accordance with the present invention.

[0021] Figure 10 is a flowchart illustrating a process of characterizing a target physiological parameter in accordance with the present invention.

### Detailed Description of the Preferred Embodiment

[0022] The following detailed description is directed to certain specific embodiments of the invention. However, the invention can be embodied in a multitude of different ways as defined and covered by the claims. In this description, reference is made to the drawings wherein like parts are designated with like numerals throughout.

[0023] Generally, the disclosed embodiments describe a process, and an associated device, that is capable of characterizing a target physiological parameter using non-invasive data. In most examples, the process and device are able to characterize the parameter using only non-invasive data, although other examples are discussed. Also, it will be understood that more than one target parameter may be selected, and that the selection of the target parameter may be static or adaptive, and may be manually or automatically chosen. In some embodiments, the present invention relates to a method or device for non-invasively

estimating the concentration level of a blood analyte. A plurality of variables may first be non-invasively measured, which may comprise at least one variable that depends on the blood analyte concentration level and/or at least one variable that does not depend on the blood analyte concentration level. The plurality of variables may be nonlinearly transformed and this transformed data may undergo a source separation method. In some embodiments, the blood analyte is glucose.

**[0024]** Definitions

**[0025]** The terms "physiological parameter" and "parameter" are applied to indicate any physiology related value or quantity or data that may be monitored to determine one or more quantitative physiological level and/or activities associated with an individual or subject. Collectively, a plurality of physiological parameters can be collected in a database, or such other stored or measured collection of parameters, over a time interval or period, or at one time point, or continuously to indicate a physiological state of a given subject. For example, physiological parameters that can be measured and indicated include analyte, hydration or moisture, fat or lipose, cardiac output, respiration, oxygen saturation, blood pressure, cellular or tissue characteristics such as cancers, temperature, or other such physiology related information. The general term "parameter" may also refer to an environmental value or data which may directly or indirectly affect or influence a physiological parameter such as ambient information (e.g., room temperature or moisture). The term "property" may be generically interchanged with the term "parameter".

**[0026]** The term "analyte" refers to a substance or chemical constituent in a biological fluid (e.g., blood or urine) that can be analyzed. In some embodiments, the analyte for measurement by the devices and methods of the present invention is glucose. In other embodiments, the analyte is one or more of lactate, pyruvate, glutamate, oxalate, D-aspartate, L-amino acid, D-amino acid, galactose, sarcosine, urate, ethanol, lysine, cholesterol, glycerol, pyruvate, choline, ascorbate, monoamine oxidases, triglycerides, and uric acid, or other electrolytes.

**[0027]** The term "blood-glucose condition" refers to a condition in which it is desirable to modulate a patient's glucose levels. In some embodiments, blood-glucose

conditions include conditions in which it is desirable to reduce blood-glucose levels. For example, high blood-glucose levels can be a blood-glucose condition. In other embodiments, blood-glucose conditions include conditions in which it is desirable to maintain blood-glucose levels at a specific value or within a range of values. In still other embodiments, blood-glucose conditions include conditions in which it is desirable to increase blood-glucose levels. In some embodiments, methods and compositions described herein can be used to first reduce blood-glucose levels and to then maintain the blood-glucose levels at a specific value or within a range of values. Blood-glucose conditions include conditions in which a patient is at risk of developing a blood-glucose condition. In one embodiment, insulin resistance is a blood-glucose condition. In another embodiment, diabetes is a blood-glucose condition.

**[0028]** Impaired glucose homeostasis (or metabolism) refers to a condition in which blood sugar levels are higher than normal but not high enough to be classified as diabetes. There are two categories that are considered risk factors for future diabetes and cardiovascular disease. Impaired glucose tolerance (IGT) occurs when the glucose levels following a 2-hour oral glucose tolerance test are between 140 and 199 mg/dl. IGT is a major risk factor for Type 2 diabetes and is present in about 11% of adults, or approximately 20 million Americans. About 40-45% of persons age 65 years or older have either Type 2 diabetes or IGT. Impaired fasting glucose (IFG) occurs when the glucose levels following an 8-hour fasting plasma glucose test are between 110 and 126 mg/dl.

**[0029]** The term "insulin" refers to a polypeptide hormone (molecular weight of approximately 5700) naturally produced by the pancreas (secreted by beta cells in the islets of Langerhans) of a mammal that controls the amounts of glucose present in the blood by stimulating the uptake of glucose by muscle and adipose tissue. Insulin can exist in various states, such as preproinsulin and proinsulin. The term "insulin" also refers to synthetic versions, such as Humulin® (available commercially from Eli Lilly).

**[0030]** The term "insulin resistance" refers to a condition or disorder in which the tissues of the body fail to respond normally to insulin. Insulin resistance manifests itself in pathologically elevated endogenous insulin and glucose levels and predisposes a mammal to the development of a cluster of abnormalities, including some degree of impaired glucose tolerance, an increase in plasma triglycerides and low density lipoprotein cholesterol (LDL)

levels, a decrease in high-density lipoprotein cholesterol (HDL) levels, high blood pressure, hyperuricemia, a decrease in plasma fibrinolytic activity, an increase in cardiovascular disease and atherosclerosis (Reaven, G. M. *Physiol Rev.* 75(3): 473-86, 1995). Decompensated insulin resistance is widely believed to be an underlying cause of non-insulin dependent diabetes mellitus (NIDDM). Hyperinsulinemia refers to the overproduction of insulin by pancreatic cells. Often, hyperinsulinemia occurs as a result of insulin resistance, which is a condition defined by cellular resistance to the action of insulin. Insulin resistance, as defined above, is a state/disorder in which a normal amount of insulin produces a subnormal biologic (metabolic) response. In insulin-treated patients with diabetes, insulin resistance is considered to be present whenever the therapeutic dose of insulin exceeds the secretory rate of insulin in normal person.

[0031] The term "non-invasive" means not requiring breaking the integrity of the body surface. Non-invasive blood analyte concentration level estimation techniques do not require, for example, breaking of the skin to collect blood for analysis, i.e., penetrating the dermis. It may be desirable and still non-invasive, however, to penetrate the outermost layer of the skin, the epidermis, particularly the stratum corneum.

[0032] Non-invasive Characterization of Physiological Parameters

[0033] As will be further described in this application, target physiological parameter(s) may be characterized by using data collected using non-invasive measurements of two or more patient or environmental conditions. The measurements may include data collected from each of multiple disparate physical properties, or data collected from multiple disparate measurements of a single physical property. Such target parameters include monitoring or measuring of blood analyte information (e.g., blood chemistry such as oxygen saturation, hemoglobin, glucose and lactate concentrations), body composition (such as lipid or fat composition/content), cellular/tissue characterization or physiological changes, hydration and fluid volumes, body mass or body water content, blood flow or pressure, pulse information, or cardiovascular information. Such information may be specific or generic, and may be collected or stored as further described herein.

[0034] In some cases, the disclosed characterization process takes advantage of the fact that improved results sometimes can be obtained by deriving the target physiological parameter from measuring the aggregate effect of changes in or on that parameter. The target physiological parameter can be derived from multiple disparate measurements of physiological or environmental properties. Disparate in this context means that the properties are physically different in nature. The measurements can be from the same parameter or from different parameters. For example, separate measurements can be made of the same parameter over different times or conditions or modalities, or separate measurements can be made of multiple parameters. Alternatively, the measurements can be combinations thereof. The physical properties should each be independently capable of measurement, and preferably have an identifiable relationship, which may or may not be initially obvious, with the character of the target physiological parameter. In this way, a final result may be predicted from the aggregate effect of changes in the physical properties.

[0035] For example, target parameter may be derived from measurements of that parameter utilizing different methods. One such example is that changes in hydration level simultaneously affect optical and bio-impedance properties of an animal subject. A particular hydration level implies a particular combination of the values for optical and bio-impedance properties. By deriving the hydration level from the aggregate effect on these properties, a more accurate result can be obtained than can be obtained from either of these properties alone or by merely attempting to compensate for inaccuracies introduced into the system, for example, by environmental changes. It will be understood in this application that the term animal refers to both human and non-human animals.

[0036] Alternatively, for example, target parameter can be derived from measurements of that parameter under different conditions or times. For example, a depth selective skin impedance spectrometer is ideal to measure impedance across different areas or layers of the skin. Electrical impedance of biological tissues varies with different settings and frequency. Different settings such as varying energies or frequency intervals contain different types of information. For example, impedance at lower frequencies is influenced by the extra-cellular environment and impedance at higher frequencies by the structure and shape of the cells and the cell membranes (*Foster & Schwan, Crit. Rev. Biomed. Eng. (1989) 17:25-104.*



[0037] Alternatively, for example, it may be desirable to combine measurements of several independent parameters to achieve a high-specificity composite measurement. For example, the method of utilizing bio-impedance information is not specific to any blood analyte and is dependent upon the presence of other biological molecules and electrolytes. In addition, the impedance values are highly dependent on temperature and the volume of tissue being analyzed. However, the combination of impedance with other glucose-dependent physiological variables such as skin temperature, sweat generation and monitoring of other hydrates, blood flow and other cardiovascular information, perfusion, as well as other physiological values may provide increased specificity of the desired analyte information.

[0038] In order to properly and reliably characterize the target parameter, the relationship between the measurable physical property and the target physiological parameter should be defined. This can be achieved, for example, by experimentally taking measurements and utilizing such information to obtain a parameter adjustment from a particular combination of results, or alternatively predicting the effects of changes in the physiological parameter on the properties using a mathematical model of animal physiology (see, e.g., T. Forst, T., et al., *Diabetes Tech. & Ther.*, 2006, 8(1): 94-101). In other examples, an algorithmic function may be defined. In other words, independent sources of information on body parameters may be used at the same time in order to obtain the complementary information on unknown parameters. In one embodiment measurements are taken as an independent source of information.

[0039] In a more specific example, the disclosed characterization process provides a method of non-invasively determining a target physiological parameter of a subject. The process detects and generates measurement data representing at least two disparate physical properties of the subject, each of the disparate physical properties having a value that varies in dependence on the target physiological parameter and is independently capable of giving a measurement thereof. The measure data is processed to isolate, identify, and characterize the physiological parameter from the aggregate effect of the target physiological parameter on the physical properties. It will be understood in this context that the measurement data may be generated in any manner that creates electrical signals representing the property that are suitable for further processing. They can, for example, be generated by transducer(s) that

actively generate(s) signal(s) from some physical phenomenon, such as pulse rate. Alternatively, the signals could also originate within the body and be, for example, ECG signals, which are merely detected by a passive pick-up.

[0040] More than one measurable component may be extracted from the signals during processing. For example, in the case of a complex bio-impedance the final result may depend on such values as aggregate impedance, aggregate phase, and aggregate maximum rate of change of impedance.

[0041] In another aspect, a non-invasive apparatus is provided for determining or characterizing a physiological parameter of a patient. The apparatus or device has at least two sensors for generating and/or detecting measurement signals representing disparate physical properties of the subject, each of the disparate physical properties having a value that varies in dependence on the target physiological parameter and is independently capable of giving a measurement thereof. A processor is configured to isolate, identify, and characterize the physiological parameter from the aggregate effect of the target physiological parameter on the physical properties. The processor may derive the physiological parameter from adaptation data stored in a memory or from a mathematical algorithm or model of the animal (human or non-human) physiology. It will be understood that the sensors may be optical, mechanical, or electrical, digital or analog, or other such modality. In a preferred embodiment, at least one of the sensors provides an RF or bio-impedance signal. Typical target physiological parameters that can be characterized include water, electrolyte, fat, analyte, glucose, hemoglobin, lactic acid, cardiac output, respiration, oxygen saturation, blood pressure, pulse, and the like.

[0042] The examples disclosed herein provide a device and method for performing non-invasive, accurate, measurement or characterization of physiological parameters of a living body, by combining seemingly disparate physiological parameters, such as dielectric characteristics (e.g., bio-impedance and/or bio/capacitance information), perfusion information, temperature, hydration information, cardiovascular information and such other such physiological information, each which in itself may not provide specific and selective information, to measure and analyze specific aspects of a patient's physiology, such as cardiac output, blood pressure, body composition (e.g. local and total body water, fat and electrolytes) and blood chemistry such as oxygen saturation, hemoglobin, glucose and lactate

concentrations. The use of multiple inputs from disparate sources gives more accurate results than can be obtained from a single source, or a single source that is merely compensated. Further, such devices and processes are more immune to changes in environmental and use conditions, and therefore are useable and practical in a wide range of applications and environments.

[0043] Referring now to Figure 1, a method of characterizing a physiological parameter is illustrated. Characterization method 10 advantageously enables a simplified and robust process for enabling the characterization of a physiological parameter using non-invasive data. In some example uses, this would enable a simple portable device to noninvasively measure and monitor blood analyte information, such as glucose levels. Such a device would have improved accuracy as well as less sensitivity to environmental conditions. In this way, a patient may easily and painlessly measure and monitor a physiological parameter such as glucose level. With the more patient-friendly processes enabled by method 10, patients are likely to more consistently monitor their physiological parameters, thereby increasing treatment effectiveness and improving an overall quality of life.

[0044] Characterization method 10 may characterize more than one physiological parameter, but in many cases will focus on one particular physiological parameter. The physiological parameter may include a blood analyte level, the detection of tissue abnormality, cancer detection, heart rate or heart tissue issue, fat composition, tissue characterization, characterization of blood flow pressure, electrolyte concentration or levels, blood content or hemoglobin levels, lactic acid level, oxygen saturation information, and respiration indicators. It will be appreciated that other physiological parameters may be characterized using method 10. The target physiological parameter is selected for the device as shown in block 12. In one example, the physiological parameter may be a glucose level, although additional or other physiological targets may be selected.

[0045] Block 14 shows that data is collected from a patient. Typically, the data is collected for patient using noninvasive sensors. The sensors may be, for example, electrical, RF or other electromagnetic, optical, mechanical, and may be integrated into a single device or may be separated into multiple interconnected devices. In some cases, other patient data may be collected using invasive sensors. For example, some blood information, flow rate

information, or blood pressure information may be obtained invasively. Also, it will be understood that some data may be collected and processed in real time, while other data may be collected and stored for later processing. In this way, data may be collected at one time, and then used at another time or other location to provide characterization results. In some cases only a single type of patient data may be collected, and in other processes multiple types of data may be collected. For example, it may be useful to capture RF impedance data for patient, as well as body temperature data. It will be appreciated that sensors for collecting patient data are well known, and will not be described in detail herein.

[0046] The data collected from the patient in block 14 generally falls into two categories. First, at least one of the sets of data collected from the patient has a known and direct relationship 19 with the target physiological parameter. This means, for example, that a change in the target physiological parameter causes a change in that set of data. It will be appreciated that the set of data may have other influences that affect the final values of the data set, but these other influences will be eliminated or reduced in other aspects of the characterization process 10. Second, the patient data may also include indirect information 18. Indirect information 18 is not used to directly measure the value for the target physiological parameter, but is used in other aspects of characterization process 10 to provide identification, filtering, or scaling functions. These indirect functions are useful to minimize environmental effects, and to account for the particular current situation of the patient. For example, some physiological parameters may be naturally higher and lower according to the body temperature of the patient. Accordingly, although measuring body temperature does not directly indicate the level of the target physiological parameter, using the body temperature will provide a normalization, calibrating or scaling process to provide more meaningful and consistent information.

[0047] Characterization process 10 also allows for the measurement of environmental conditions as shown in block 20. These environmental conditions also provide indirect information useful for providing filtering, identification, or scaling processes according to environmental conditions. For example, some physiological parameters may be naturally higher or lower according to the time of day. By accounting for time of day, characterization process 10 will provide a normalization or scaling process to provide more

meaningful and consistent information. It will be appreciated that the environmental conditions may be measured along with the patient data, or may come from other sensors and other devices. The environmental data 20 and the indirect data 18 may be used to drive data processes 21 for preprocessing patient data 19. The preprocessing of methods 21 may be relatively simple filtering processes, or may be configured as more sophisticated adaptive adjustment processes. However, in most cases preprocessing 21 may not be necessary, and if used, will be relatively simple preprocessing methods. For most effective use of characterization process 10, it is desirable that patient data 19 be provided to follow-on process steps with minimal information loss. Accordingly, many of the more complex filtering and processing algorithms, such as PCA, may be undesirable due to their large loss effects.

[0048] Through historical information or lab tests, the relationship between the target physiological parameter and the data collected from the patient 19 is understood. In some cases, the relationship may be generally linear, however in many cases the relationship is nonlinear. To increase the effectiveness of follow-on steps in characterization process 10, it is desirable that the patient data 19 have a generally linear relationship to the target physiological parameter. Accordingly, if the patient data is understood to have a generally linear relationship with the target physiological parameter, then the data 19 is passed to the separation process 25. However, if the patient data 19 has a more non-linear relationship, then the patient data 19 is passed to a linearization process 23. In linearization process 23, the patient data 19 is scaled or otherwise adjusted so that the embedded physiological target data has a more linear relationship with the physiological parameter. The linearization process may be implemented in an algorithmic form, as a lookup table, or other modeling or scaling process. Whether the patient data is received directly from block 14, or is first processed in linearization block 23, the data received 24 into the separation block 25 has a generally linear relationship between the data and the target physiological parameter.

[0049] In block 25, the linearized data 24 is processed using a blind signal source (BSS) separation process. In one example, the BSS is an independent component analysis (ICA) process. It will be appreciated that other signal separation processes may be used. The BSS process is used to separate the linearized data 24 into separate independent signal sources, with one of the signals directly relating to the target physiological parameter.

Independent component analysis (ICA) is a computational method for separating a multivariate signal into additive subcomponents supposing the mutual statistical independence of the non-Gaussian source signals. It is a special case of blind source separation. The statistical method finds the independent components (aka factors, latent variables or sources) by maximizing the statistical independence of the estimated components. ICA can identify linear subspaces of independent components from the signal. In its simplified form, ICA operates an "un-mixing" matrix of weights on the mixed signals, for example multiplying the matrix with the mixed signals, to produce separated signals. The weights are assigned initial values, and then adjusted to maximize joint entropy of the signals in order to minimize information redundancy. This weight-adjusting and entropy-increasing process is repeated until the information redundancy of the signals is reduced to a minimum. More generally, by applying signal separation techniques, linear components can be identified which are independent of each other. Since the invention signal separation techniques can extract original signal from multi-dimensional observation signals mixed with high noise, cleaner signals can be extracted or separated which show higher correlation with the desired physiological parameter. Algorithms for ICA include infomax, FastICA and JADE, but there are many others also.

[0050] Once independent signal sources have been identified in block 25, in block 27 the particular target signal is identified. The target signal may be identified due to its particular characteristics or relationship with other signals, or may be identified due to its relationship with other data, such as indirect information 18 or measured environmental conditions. Once the target signal has been identified, it may be scaled to give a consistent normalized result as shown in block 32. Scaling may be assisted with the use of the indirect information or environmental condition information 20. Once the scaled result has been determined, it may be presented as shown in block 34. The result may be indicated on a graphical display, printed, communicated to other devices, or used to set alarms. It will be appreciated that the particular type of presentation may be adjusted according to application needs.

[0051] Referring now to Figure 2, a characterization method 50 is illustrated. It will be appreciated that characterization methods 50 may be used to characterize a wide

variety of physiological parameters. It will also be understood that characterization process 50 may be used to characterize a single physiological parameter, or may be used to characterize multiple physiological parameters. Generally, characterization process 50 has four steps: first 52, data is collected from the patient and the environment using non-invasive techniques; second 54, a generally linear relationship is provided between the collected data and the target physiological parameter; third 56, a signal is identified from the data set that is indicative of the target physiological parameter; and fourth 58, the selected signal is scaled in process for presentation. These steps enable characterization process 50 to provide a highly accurate characterization of the target physiological parameter, even under changing patient or environmental conditions. In this way, process 50 may be implemented in a wider range of applications and environments, and may be used with greater confidence and less pain than previous devices or processes.

[0052] In step 52, noninvasive data is collected from the patient 61 or from the environment 63. Typically, data is collected from the patient using noninvasive skin-surface sensors. These sensors may be used to measure electrical, optical, temperature, or humidity characteristics, for example. Some of these characteristics may measure surface characteristics, while others may indicate characteristics of underlying tissue or fluids. Some of the sensors may be configured to measure an existing property, such as temperature, while other sensors may actively provide a stimulation. For example, some sensors may provide an RF frequency signal for measuring an RF impedance, while other sensors may provide a light signal for measuring an optical property. It will be understood that a wide range of noninvasive sensors may be used. At least some of the data collected from the patient 61 has information that has a known direct relationship with the target physiological parameter as shown by arrow 264. This means, for example, that a change in the target physiological parameter causes a change in that set of data. Other data from the patient and from the environment may have an indirect relationship as shown by arrow 62. The data 64, which has a known relationship with the target's physiological parameter, preferably has a generally linear relationship prior to use in the identification step 56. Accordingly, in step 66 the target data may be classified according to its linear or nonlinear relationship with the target parameter. In some cases, the determination may be predefined, and in other cases the

determination may be made during preprocessing steps. If the data has a linear relationship, then the data is passed to the identification step 56. If the data is not linear, the data is passed through an algorithmic, table, modeling, or other scaling process 65 to adjust the data for a more linear relationship. This linearized data is then passed to identification step 56.

[0053] In block 56, the data is first separated into independent sources as shown in block 67, and then the signal associated with the target physiological parameter is identified in block 69. Typically, the separation process will be a blind signal source process, for example, an independent component analysis, or may have another signal separation process applied. With the proper signal identified, the signal is scaled 71, typically using the indirect information 62. The scaled result is then presented as shown in block 73.

[0054] Figure 3 is a flowchart illustrating a process 100 of estimating a blood analyte concentration level. Depending on the embodiment, additional steps may be added, others removed, and the ordering of the steps rearranged.

[0055] Starting at step 105 of process 100, patient data may be obtained. The patient data may be collected using sensors, which may be mechanical, electrical, or optical. The data may be obtained by other input means and/or by measurement means, and the patient data may be obtained from one or more devices. The plurality of properties is preferably non-invasively measured. In preferred embodiments, data representing multiple physical properties are measured nearly simultaneously. In alternate preferred embodiments, the data from each physical property is measured sequentially or over a period of time. In some embodiments, no measurement is invasively made at approximately the same time as the non-invasive measurements are made. In some embodiments, both invasively measured and non-invasively measured properties are measured initially to determine relationship between the collected data and between the blood analyte concentration level, as described in greater detail below. The physical properties may be measured using any signals generated in any manner which represent the property(ies) that are suitable for further processing. They can be generated, for example, by transducer(s) that actively generate and record signals from some physical phenomenon. Alternatively, the signals could also originate within the body and be detected by active or passive pick-up.



[0056] In some embodiments, at least one of the measure physical properties depends on a blood analyte concentration level. One or more of the physical properties may be related to a patient. One or more of the physical properties may be measure using a dielectric measurement. The dielectric measurement may be an impedance spectroscopy measure. The impedance measure may be a radio-frequency (RF) or bio-impedance impedance measure. One or more of the physical properties may be measured using an optical sensor and detector (e.g., IR, Doppler, reflectance, Raman, polarization, fluorescence, etc.). One or more of the physical properties may be measured using a capacitance variable. One or more of the physical properties can be measured using audio or pulse wave measurements. One or more of the physical properties may be measured using a current variable. One or more of the physical properties may be measured using an imaging technique. One or more of the physical properties may be measured using an electromagnetic measurement. Other such methods will be known to those skilled in the art. The physical properties may be measured by a device positioned on and/or over the skin of a patient, and in some cases, may include an invasive device, such as an implant. In one embodiment, combinations of such measurements can be made.

[0057] In some embodiments, at least one of the types of patient data does not directly depend on a blood analyte concentration level. Without wishing to be bound to any particular theory, patient data that is insensitive to the blood analyte concentration level may still be useful for the estimation, as it may affect another physical property that is sensitive to the concentration level. Such physical properties include temperature (e.g., ambient, skin or internal), moisture such as sweat generation, perfusion or blood flow, internal or external pressure (e.g., blood pressure or device pressure), blood oximetry or pulse, as well as ECG or EEG values. In some embodiments, a patient data that does not directly depend on a blood analyte concentration level is estimated rather than measured. For example, the room temperature may be approximately known, so it may be estimated rather than measured. One or more of the measure data sets may be related to a patient, such as the body temperature of a patient. One or more of the measured data sets may be related to the environment, such as the room or ambient temperature. For example, block 108 shows that environmental data may be collected, such as time of day, humidity, temperature, ambient light, and the like. While in

some embodiments, one or more of the measured data sets are related to the time of day, in other embodiments, none of the measured data sets are related to the time of day. In some embodiments, one blood analyte concentration level may globally depend on another blood analyte concentration level but may not be sensitive to day-to-day fluctuations. To illustrate this concept, a diabetic patient may be more likely to have high blood pressure, but blood pressure readings may be uninformative as to the patient's instantaneous glucose concentration levels.

**[0058]** In one embodiment, RF impedance measurement data is collected as patient data. Electrical impedance of biological tissues varies with an applied frequency, current or voltage signal, and the impedance values may be measured and collected. Different frequency intervals contain different types of information. For example, impedance at lower frequencies is influenced by the extra-cellular environment and impedance at higher frequencies by the structure and shape of the cells and the cell membranes. In impedance spectra, this information is diffusely spread and overlapped in the whole frequency. The impedance can also be generated from the exchange of energy from an external power source, e.g., both alternating current and/or voltage and direct current and/or voltage. The alternating current and/or voltage can include alternating or a range of frequencies. A correct frequency needs to be chosen in order to develop a sensor based on impedance spectroscopy that will be sensitive to electrical changes in the blood, tissue or body. For example, glucose changes can be selected within the range of 10 Hz and 50 GHz, preferably between 1 KHz and 100 MHz. Other measurements of changes in tissue characteristics, such as tumor detection, can be selected from as low as 1 Hz to 50 GHz, preferably between 10 Hz and 200 KHz.

**[0059]** The measured data sets may include other physiological data that include but are not limited to one or more of a patient's skin temperature, a patient's body temperature or ambient temperature, a patient's skin moisture, a patient's blood flow or pressure or other vascular activity, a patient's skin/tissue hydration, an ECG variable, an EEG variable, an oxygen saturation variable, air temperature, humidity, atmospheric pressure, a skin-device pressure variable, and a device movement variable.

**[0060]** It is preferred that a plurality of measurements be taken from different and analogous sensors.

**[0061]** Pre-Processing

**[0062]** At step 110 of process 100, one or more data sets are pre-processed. As employed herein, pre-processing comprises preparing the input data (signals or information) for signal separation processing 120. In some embodiments, step 110 is not part of process 100. The one or more data sets may be measured variables and/or input variables. The pre-processing may include a variety of processes, including identifying, categorizing, filtering, transforming, calibrating, resampling, smoothing, transforming, normalizing, selecting, registration, quantization, and other similar processes, individually or in combination, such that relevant information is not lost. Preferably, the data will retain as much information, e.g., raw, to retain as much relevant or potentially relevant information as possible, contrary to steps such as normalizing or averaging, or other processes which remove information. For example, principal components analysis (PCA) is a technique for simplifying a data set by reducing multidimensional data sets to lower dimensions for analysis. Although such steps simplify processing, information which is important or potentially important is permanently lost. Pre-processing may be performed on each data set or an aggregate set of data, preferably such that the number of output components resulting from pre-processing step is equal to the number of input components.

**[0063]** Preferably, the pre-processing step 110 involves identifying and/or categorizing input information to determine whether further pre-processing is required. Information which identifies the input data sets as non-activity or static or null information, duplication, non-linearity, or other such characterization would improve processing. Filtering can include filters on each data signal or on the aggregate of signals, such as removal of non-relevant inputs. Pre-processing may be static or adaptive. For example, the output of the separation signal may influence the pre-processing step as a feed forward or feedback loop, or alternatively, the filter can be designed learned filters from prior knowledge or empirical data acquisition. Pre-processing may also include the combining of two or more measurements. For example, two or more impedance readings may be combined into a single variable if they are identical.

**[0064]** Nonlinear Transformations

**[0065]** At step 115 of process 110, one or data sets are nonlinearly transformed, if and when identified. The nonlinear transformation may be a nonlinear filtering, a look-up table, or an algorithm, for example. In some embodiments, one or more data sets that depend on a blood analyte concentration level are nonlinearly transformed while no data sets that do not depend on the blood analyte concentration level are nonlinearly transformed. For example, a data set derived from measuring an RF impedance may undergo a linearization process, whereas data regarding room temperature may not. In some embodiments, one or more data sets that do not depend on a blood analyte concentration level are nonlinearly transformed while no variables that depend on the blood analyte concentration level are nonlinearly transformed. In some embodiments, both one or more data sets that depend on a blood analyte concentration level and one or more data sets that do not depend on the blood analyte concentration level are nonlinearly transformed.

**[0066]** The nonlinear transformation may be a variety of transformations, including, without limitation, single variate transformation, polynomial transformations, e.g.,  $f(x) = a \cdot x^b + c$ , trigonometric transformations, e.g.,  $f(x) = \cosh(x)$ , exponential transformations, e.g.,  $f(x) = 1 / (1 + \exp(-x))$ , logarithmic transformations, e.g.,  $f(x) = \log(x)$ , and the like. It will be understood that if nonlinear transformations are applied to multiple variables, different or the same nonlinear transformations may be applied to the variables.

**[0067]** The specific nonlinear transformations may be determined by known relationships between a data set or physical property and another data set or between a data set and a known physiological parameter, such as blood analyte concentration level. For example, a known relationship between an impedance data set and a body temperature data set may be established and one or both of these data sets may be nonlinearly transformed based on this known relationship. In some embodiments, the nonlinear relationship is established using test data. The test data may include a set of non-invasively measured data sets and corresponding invasively measured data sets. In some embodiments, a variety of nonlinear transformations are performed on one or more non-invasively measured data sets and the estimated blood analyte concentration levels are compared to invasively measured data sets. The most accurate transformation may then be used to estimate the blood analyte

concentration levels when only the non-invasively measured data sets are measured. In some embodiments, a learning rule is used to estimate a nonlinear transformation based on the test data. The learning rule may be constrained. The learning rule may include a priori constraints and/or derived constraints. The learning rule may comprise a neural network.

[0068] In some embodiments, the nonlinear transformation step 115 is performed prior to any signal separation step 120, while in other embodiments a signal separation step 120 precedes the nonlinear transformation step 115. In some embodiments, the nonlinear transformation step 115 is performed after the pre-processing step 105. In some embodiments, the nonlinear transformation is at least partially adaptive.

[0069] Source Separation

[0070] In some embodiments, a linear mapping,  $z$ , is computed from variables,  $Y$ , such that the linear mapping,  $z$ , is correlated with the desired physiological parameter, such as a blood analyte concentration level.

$$[0071] \quad z = WY \quad \text{Eq.}$$

1

[0072] The variables,  $Y$ , may comprise non-invasively measured variables that may have been pre-processed, including transforming any  $Y$  that is nonlinear. Although the mapping may be substantially insensitive to personal and/or environmental changes, the goal is to have a system that is robust to such changes. Accordingly, the prediction weight,  $W$ , may be determined by a variety of methods. For example, test data may be used to establish a linear regression between invasively measured blood analyte concentration levels and the variables  $Y$ . However, preferably, a more complex regression model such as a neural network can be used to determine the prediction weight.

At step 120 of process 100, a source separation process is used to separate an independent signal from at least two data sets. In some embodiments, step 120 is not part of process 100. In one example, signal separation process(es) 120 includes signal separation or blind source extraction (BSE) techniques known to those skilled in the art, including non-orthogonal transformation methods. Each input data set is considered a channel of input signals to the transformation. The signal separation method is applied to the channels of input signals to

separate a multivariate signal into statistically substantially-independent components. In one specific implementation, a blind source separation (BSS) or an independent component analysis (ICA) or an independent vector analysis (IVA) method is used as the signal separation process. Blind source extraction (BSE) is a techniques that extracts a small subset of source signals from high-dimensional observed signals. See, for example: Cichocki, A., Amari, S., Adaptive Blind Signal and Image Processing: Learning Algorithms and Applications, John Wiley & Sons, New York (2002); Cichocki, A., et al.: A Blind Extraction of Temporally Correlated but Statistically Dependent Acoustic Signals, Proc. of the 2000 IEEE Signal Processing Society Workshop on Neural Networks for Signal Processing X (2000) 455-46; Smith, D., Lukasiak, J., Burnett, I.: Blind Speech Separation Using a Joint Model of Speech Production, IEEE Signal Processing Lett. 12 (11) (2005) 784-787; Zhang, Z.-L., Yi, Z.: Robust Extraction of Specific Signals with Temporal Structure, Neurocomputing 69 (7-9) (2006) 888-893; Barros, A.K., Cichocki, A.: Extraction of Specific Signals with Temporal Structure, Neural Computation 13 (9) (2001) 1995-2003; Cichocki, A., Thawonmas, R.: On-line Algorithm for Blind Signal Extraction of Arbitrarily Distributed, but Temporally Correlated Sources Using Second Order Statistics, Neural Processing Letters 12 (2000) 91-98; Mandic, D.P., Cichocki, A.: An Online Algorithm for Blind Extraction of Sources with Different Dynamical Structures, Proc. of the 4th Int. Conf. on Independent Component Analysis and Blind Signal Separation (ICA 2003) (2003) 645-650; Liu, W., Mandic, D.P., Cichocki, A.: A Class of Novel Blind Source Extraction Algorithms Based on a Linear Predictor, Proc. of ISCAS 2005, pp. 3599-3602; Liu, W., Mandic, D.P., Cichocki, A.: Blind Second-order Source Extraction of Instantaneous Noisy Mixtures, IEEE Trans. Circuits Syst. II 53 (9) (2006) 931-935.

**[0073]** Independent component analysis (ICA) is a computational method for separating a multivariate signal into additive subcomponents supposing the mutual statistical independence of the non-Gaussian source signals. It is a special case of blind source separation. The statistical method finds the independent components (aka factors, latent variables or sources) by maximizing the statistical independence of the estimated components. ICA can identify linear subspaces of independent components from the signal. In its simplified form, ICA operates an "un-mixing" matrix of weights on the mixed signals, for example

multiplying the matrix with the mixed signals, to produce separated signals. The weights are assigned initial values, and then adjusted to maximize joint entropy of the signals in order to minimize information redundancy. This weight-adjusting and entropy-increasing process is repeated until the information redundancy of the signals is reduced to a minimum. When applied to signal Y, the ICA method may identify a number of subspaces for which signals are independent of each other. More generally, by applying signal separation techniques, linear components can be identified which are independent of each other. Since the invention signal separation techniques can extract original signal from multi-dimensional observation signals mixed with high noise, cleaner signals can be extracted or separated which show higher correlation with the desired physiological parameter. Algorithms for ICA include infomax, FastICA and JADE, but there are many others also.

[0074] Although process 120 may use an ICA process, it will be understood that other signal separation processes may be used in accordance with this disclosure, including extensions of ICA. Many different algorithms for solving the separation can be found in the literature, including some of the better known algorithms such as JADE (Cardoso & Souloumiac (1993) *IKE proceedings-F*, 140(6); SOBI (Belouchrani et al. (1997) *IEEE transactions on signal processing* 45(2)); BLISS (Clarke, I.J. (1998) *EUSIPCO 1998*); Fast ICA (Hyvarinen & Oja (1997) *Neural Computation* 9:1483-92); and the like. A summary of the most widely used algorithms and techniques can be found in books and references therein about ICA and BSS (e.g., PCT Application Nos. WO 05/052848 and WO 03/073612; Girolami, M., *Advances in Independent Component Analysis*, Springer (December 2006); Stone, J.V., *Independent Component Analysis: A Tutorial Introduction*, MIT Press (Sept. 2004); Roberts and Everson, *Independent Component Analysis: Principles and Practice*, Cambridge University Press (March 2001); Hyvarinen et al., *Independent Component Analysis*, 1st edition (Wiley-Interscience, May 2001); Haykin, Simon. *Unsupervised Adaptive Filtering, Volume 1: Blind Source Separation*. Wiley-Interscience; (March 31, 2000); Haykin, Simon. *Unsupervised Adaptive Filtering Volume 2: Blind Deconvolution*. Wiley-Interscience (Mar. 2005); and Mark Girolami, *Self Organizing Neural Networks: Independent Component Analysis and Blind Source Separation (Perspectives in Neural Computing)* (Springer Verlag,

September 1999). Singular value decomposition algorithms have been disclosed in Adaptive Filter Theory by Simon Haykin (Third Edition, Prentice-Hall (NJ), (1996).

[0075] Also contemplated are extensions of ICA developed to allow ICA applicable to a wider range of data analysis area. These extensions include noisy ICA, independent subspace analysis, multidimensional ICA, (post-)nonlinear ICA, tree-dependent component analysis, subband decomposition ICA, independent vector analysis (IVA, PCT Application No. PCT/US2006/007496; U.S. Provisional App. Nos. 60/891,677, 60/777,900 and 60/777,920; Kim et al., Independent Vector Analysis: An Extension of ICA to Multivariate Components. ICA 2006: 165-172; Lee, et al., Complex FastIVA: A Robust Maximum Likelihood Approach of MICA for Convolutional BSS. ICA 2006: 625-632; Tacsu Kim, "Independent Vector Analysis," Ph. D. Thesis, KAIST, Feb., 2007; each incorporated herein by reference.

[0076] Other non-orthogonal transformation methods contemplated for source separation, such as Varimax, Promax, variational methods and so forth, can also be used. In one experiment, one-lead ECG signals are isolated and time-aligned into 5000 heartbeat cycles, and separated by an ICA method into 150 components. Although process 120 may use an ICA process, it will be understood that other signal separation processes may be used in accordance with this disclosure. The source separation process 120 may be a linear source separation process. In some embodiments, a first data set that depends on a blood analyte concentration level also depends on a second data set. A source separation process as described herein may be used to improve a correlation between the first variable and the blood analyte concentration level. The source separation process may be at least partially adaptive. The source separation process may comprise one or more constraints. The constraints may include a priori constraints and/or derived constraints. Parameters, equations and/or other properties related to the source separation process may be determined by a learning rule, such as a neural network.

[0077] Post-Processing

[0078] At step 125 of process 100, one or more outputs from the separation process described herein may undergo post-processing. In some embodiments, step 125 is not



part of process 100. In some embodiments, one or more signals that have been separated by the source separation process are post-processed. For example, the post processing steps may include identifying the signal source associate with the target physiological parameter. In other cases, the signal separation process may be adjusted to only pass the proper signal to post processing. In some embodiments, one or more variables that are estimated to be correlated to a known physiological parameter, such as a blood analyte concentration level, undergo post-processing.

[0079] The post-processing may include scaling and/or applying an offset. The scaling factor and/or the offset may be determined by a test data set, or may be responsive to another patient data set or environmental data set. The test data set may comprise both separated data derived from non-invasively measured variables and invasively measured data. The post-processing may include combining at least two of the separated variables. In some embodiments, the post-processing comprises linear processes. In some embodiments, the post-processing comprises non-linear processes. In some embodiments, the post-processing is at least partially adaptive. In some embodiments, the post-processing comprises constraints, which may include a priori constraints and/or derived constraints.

[0080] Output Variables

[0081] At step 130 of process 100, one or more characteristics of the target parameter are output. In some embodiments, step 130 is not part of process 100. A system and/or method described herein may estimate and may output a desired physiological parameter; a blood analyte concentration level, for example. In some embodiments, an output characteristic is a single estimated concentration level. In some embodiments, the output characteristic comprises a range of concentration levels, or a rate of change. The range of levels may indicate, for example, the confidence in the calculation. The range of levels may indicate that the level is within a specific physiological range. For example, after the concentration level is calculated, the system and/or method may simply indicate that it is within a range of levels deemed normal.

[0082] In some embodiments, the output variable indicates whether the estimated physiological parameter level is above or below a threshold value. For example, an output

variable may indicate that a blood analyte concentration level is too high, such that a counteracting drug such as insulin should be injected. In some embodiments, the output characteristic is not a number. The output characteristic may be an interpretation of a concentration level. For example, the output variables may comprise "below acceptable level", "acceptable level", and "above acceptable level". The output characteristic may provide instructions to the patient based on the blood analyte concentration level. The instructions may relate to the type, timing, and/or dosage of treatments to be administered, to dietary advice, and/or advice about seeking professional assistance, such as a doctor or an emergency unit. In some cases, the output may be an alarm. In some embodiments, the output variable comprises a concentration level relative to another concentration level. For example, the output variable may comprise a ratio of the blood analyte concentration level relative to the concentration level most recently measured or relative to the average concentration level deemed to be acceptable. In some embodiments, the output characteristic comprises a scaled version of the blood analyte concentration level. For example, the concentration level may be scaled to a 1-10 scale, such that a "1" indicates concentration levels far below acceptable values and a "10" indicates concentration levels far above acceptable values. In some embodiments, the output may be useful to the patient, to the primary care giver or physician, or the medical provider, including emergency personnel.

[0083] Post-processing components of methods and/or systems described herein may comprise conversion components to convert estimated blood analyte concentration levels to an output characteristic described herein. In some embodiments, the conversion depends on details of the concentration level calculations, such as when the output characteristic indicates the confidence in the estimate. In some embodiments, the conversion is a fixed conversion, such as implementing a fixed relationship between blood analyte concentration levels and output characteristic describing whether the levels are acceptable. In some embodiments, the conversion is customized to the patient. This customization may include incorporation of patient-specific variables, such as the patient's weight, to determine whether, for example, the blood analyte concentration level is within an acceptable range. The customization may include learning rules, for example, to determine how the blood analyte

concentration level relates to trends in the patient's concentration levels, the variability of the patient's concentration levels, and/or the mean of the patient's concentration levels.

[0084] The characteristic may be output by displaying a visual output. For example, the output may comprise a graph. The graph may indicate an acceptable range of blood analyte concentration values (for example by a bar graph or shaded region) and may also indicate the estimated concentration value (for example by an asterisk). The graph may indicate multiple estimated blood analyte concentration values. For example, the graph may comprise a bar graph, wherein each bar indicates an estimated concentration level of a different blood analyte. As another example, the graph may comprise a graph of an estimated blood analyte concentration level as a function of time. In the latter example, methods and/or system described herein may store estimated blood analyte concentration values. The output characteristic may comprise an average of estimated blood analyte concentration values. For example, all estimated concentration values for a given day may be averaged. As another example, estimated concentration values from a given time of day may be averaged across days.

[0085] In some embodiments, methods and/or systems may comprise components or may be used to identify potential causes of specific blood analyte concentration values. For example, by calculating the average estimated blood analyte concentration values for a given temperature range, it may be determined that, for example, high concentration values are more common during high temperatures. Additional components may allow for inputs by the user to estimate triggers of specific blood analyte concentration values. For example, the patient may enter food consumed and the output variables may indicate that a specific type of food or characteristic of food is likely to cause high blood analyte concentration values.

[0086] It will be understood that in some embodiments, a system and/or device described herein may display additional output characteristic. For example, in an instance in which the device is a watch, the device may also display the time of day. The system and/or device may include an alarm and/or timer component that may be used to indicate when an action is required or suggested by the patient. For example, in an embodiment in which the blood analyte concentration levels are estimated at regular intervals, an alarm may sound regularly throughout the day to alert the patient that the concentration levels should be

estimated. In such instances, an alert may be necessary if, for example, the device requires user input, requires a lack of motion by the user, or requires other situational characteristics. The alert may also or instead act as a mechanism to attract the patient's attention to the estimated blood analyte concentration level. As another example, in an embodiment in which the blood analyte concentration levels are continuously estimated or are estimated at regular intervals without requiring the patient's attention and/or input, an alarm may be used to alert the user if, for example, the estimated concentration levels are out of the range considered appropriate. The device may comprise an audio transducer, such as a speaker.

**[0087]** Test Data and Adaptation

**[0088]** In order to determine relationships between non-invasively measured data sets and/or between non-invasively measured data sets and a blood analyte concentration level, test or historical data may be used. In these instances, both invasively measured data and non-invasively measured data may be obtained. In preferred embodiments, the data sets are obtained nearly simultaneously. Such test data may be used to adjust or adapt a part of a method and/or system described herein. For example, the test data may be used to set or adapt parameters, equations, and/or other properties related to one or more of pre-processing, nonlinear transformations, source separation processes, and post-processing. In some embodiments, known parameters are used to calibrate a method and/or system described herein. For example, the patient's weight may be used to determine one or more parameters, equations and/or other properties.

**[0089]** In some embodiments, parameters, equations, and/or other properties are determined prior to analysis of the test data. The test data may then be used to verify the accuracy of the pre-determined parameters, equations and/or other properties and/or to alter the pre-determined parameters, equations, and/or other properties. In some embodiments, a plurality of parameters, equations, and/or other properties are identified prior to analysis of the test data. The test data may then be used to determine the preferred parameters, equations, and/or other properties. In some embodiments, parameters, equations, and/or other properties are not identified before analysis of the test data. The parameters, equations, and/or other properties may be identified by, for example, a learning rule.

[0090] In some embodiments, test data is used to determine which outputs of a source separation component of a method and/or system described herein is related to a blood analyte concentration level. For example, test data could be used to determine the number of outputs from the source separation component related to the concentration level. These outputs may later be combined. Test data may also be used to determine which of the separated variables is related to the concentration level. For example, test data may reveal that an output with a given variation, strength, auto-correlation and/or spectral property can be identified as related to the concentration level. The test data may be collected for every individual patient, such that, for example, parameters, equations, and/or other properties are optimized for the individual. Alternatively, test data may be collected from one or more individuals to determine appropriate parameters, equations and/or other properties to be used across patients.

[0091] In some embodiments, test data may first be collected and then a blood analyte concentration level may subsequently be estimated based on non-invasively measured data. In some embodiments, test data is collected periodically between estimations based only on non-invasively measured data. For example, initial parameters, equations and/or other properties related to one or more of pre-processing, nonlinear transformations, source separation processes, and post-processing may be determined by initial test data or another method. Blood analyte concentration levels may be estimated for a defined interval, such as a week. Test data may then be collected, and the parameters, equations and/or other properties may be adjusted. Alternatively, blood analyte concentration levels may be estimated until there is concern that the estimations are of a specific inaccuracy. For example, if the concentration levels are not varying as much as expected between estimations or are higher or lower than would normally be expected. Test data may then be collected, and the parameters, equations and/or other properties may be adjusted.

[0092] Devices

[0093] A system described herein may comprise a device, such as device 200 as shown in Figure 4. The device 200 may comprise a measuring component 205 configured to measure a plurality of physical properties or environmental conditions; a calculation

component 210 configured to pre-process at least one data set, nonlinearly transform at least one data set, separate data sets into independent signals, and/or post-process at least one signal; a display component 215 configured to display an output; an adaptation component 220 configured to perform an adaptation according to test data or historical evaluation; a data storage component 225 configured to store data or results; and/or an input component 230 configured to receive user and/or device input. Depending on the embodiment, additional components may be added, others removed, and connections between components may be added and/or removed.

[0094] In some embodiments, the device 200 comprises a measurement component 205 configured to measure a plurality of patient physical properties and environmental conditions. The patient physical properties and environmental conditions may comprise any herein. It will be appreciated that some of the measurement or sensor devices may be discreet devices that connect or couple to the device 200. In other cases the measurement or sensor devices may be in a single device 200.

[0095] In some embodiments, the measurement component 205 measures an impedance and/or a dielectric property of a patient. The measurement component 205 may comprise one or more electrodes. The one or more electrodes may comprise a capacitive fringing field electrode. The one or more electrodes may comprise two or more electrodes. The two or more electrodes may be spaced apart from each with a separation of, for example, between 200  $\mu\text{m}$  and 4 mm. In other embodiments, the electrodes may be inches or feet in separation. The electrodes may be used to generate electromagnetic fields into the skin and/or various tissue layers underneath the skin of a patient. A plurality of electromagnetic fields may be generated by the electrodes which may achieve different penetrations.

[0096] In some embodiments, the measurement component 205 measures a hydration property of a patient. The hydration property may comprise a skin and/or underlying tissue hydration level. The measurement component 205 may comprise a sweat/humidity sensor. The sweat/humidity sensor may comprise an electrode. The electrode may comprise an interdigitated electrode and may utilize a galvanic response based measuring technique.

[0097] In some embodiments, the measurement component 205 measures an optical property of a patient. The optical variable may comprise a variable related to the optical properties of the patient's skin. The optical property may be related to the visible spectrum. The measurement component 205 may comprise an optical sensor. The optical sensor may comprise one or more micro-spectrophotometers. The optical sensor may comprise two or more micro-spectrophotometers. The optical sensor may comprise an optical sensor head, which may comprise a fiber-optic transmitter and one, two or more receivers. In some embodiments, the device 200 comprises an input light source. The receivers may be at one, two or more separation distances from the input light source.

[0098] In some embodiments, the measurement component 205 measures a pressure property of a patient. The pressure property may comprise a variable indicating the pressure of the device on the patient's skin. The measurement component 205 may comprise a piezoelectric element. The piezoelectric element may be an integrated piezoelectric sensor. In some embodiments, the measurement component 205 measures a movement property of a patient. The movement property may comprise a variable indicating the movement of the device 200. The movement of the device 200 may be absolute or relative to, for example, a movement of the patient. The measurement component 205 may comprise an accelerometer. In some embodiments, the measurement component 205 measures a weather-related condition. The weather-related condition may comprise a temperature, a pressure variable and/or a humidity variable. The measurement component 205 may comprise a thermometer, barometer, psychrometer and/or hygrometer. In some embodiments, the measurement component 205 measures a capacitance property of a patient and/or a current property of a patient. In some embodiments, the measurement component 205 measures one or more of body temperature, skin temperature, blood flow, blood pressure, an ECG variable, an EEG variable, and an oxygen saturation variable. The measurement component 205 may include a component to measure any of these properties or conditions.

[0099] In some embodiments, the measurement component 205 measures both an analyte-sensitive physical property and an analyte-insensitive physical property. In other embodiments, the measurement component 205 measures either an analyte-sensitive physical property or an analyte-insensitive physical property. The device 200 may receive one or more

analyte-sensitive data sets and/or one or more analyte-insensitive data sets via the input component 230. In some embodiments, the measurement component 205 measures an analyte-sensitive physical property and the input component 230 receives an analyte-insensitive physical property or condition as an input.

[00100] In some embodiments, the device 200 includes a calculation component 210. The calculation component 210 may comprise one or more of a pre-processing component 305, a nonlinear calculation component 310, a source separation component 315, and a post-processing component 320, as shown in Figure 5. Depending on the embodiment, additional components may be added, others removed, and connections between components may be added and/or removed. For example, the pre-processing component 305 and/or the post-processing component 320 may be removed from the calculation component 210.

[00101] In some embodiments, the calculation component 210 includes a pre-processing component 305. The pre-processing component 305 may pre-process one or more measured data sets which may be provided by the measurement component 205 of the device 200 and/or one or more input data which may be provided by the input component 230 of the device 200. The pre-processing may include a variety of processes, such as a normalization process. Pre-processing may also include the combining data sets from two or more measurements. For example, two or more impedance readings may be combined into a single data set.

[00102] In some embodiments, the calculation component 210 includes a nonlinear calculation component 310 configured to nonlinearly transform at least one data set. The at least one data set may comprise data sets measured by the measurement component 205 of the device 200, data input via the input component 230 of the device 200, and/or a data processed by the pre-processing component 305 of the calculation component 210. The at least one data set may comprise an analyte-sensitive data set and/or an analyte-insensitive data set. The at least one data set may comprise a pre-processed data set and/or a data set that has not been pre-processed. The nonlinear calculation component 310 may include constraints that may comprise a priori constraints and/or derived constraints. The nonlinear calculation component 310 may include one or more learning rules.



[00103] In some embodiments, the calculation component 210 includes a linear calculation component. The linear calculation component may comprise a source separation component. The calculation component 310 may include a source separation component 315. The source separation component 315 may comprise a blind source separation module configured to separate at least two signals. The blind source separation module may comprise, for example, an ICA and/or an IVA module. The linear calculation component and/or the source separation component 315 may be configured to identify one or more signals related to a blood analyte concentration level. The linear calculation component and/or the source separation component 315 may receive as inputs one or more of measured data sets provided by the measurement component 205 of the device 200, input data provided by the input component 230 of the device 200, pre-processed data sets provided by the pre-processing component 305 of the calculation component 210, and nonlinearly transformed data sets provided by the nonlinear calculation component 310 of the calculation component 210.

[00104] In some embodiments, the calculation component 210 includes a post-processing component 320. The post-processing component 320 may be configured to scale and/or impose an offset to one or more signals from the separation process 315. The post-processing component 320 may be configured to combine signals and/or to identify a desired signal. The post-processing component 320 may be configured to calculate the confidence and/or error of a blood analyte concentration level estimate. The post-processing component 320 may be configured to convert a blood analyte concentration level estimate into an output form. The post-processing component 320 may act on one or more of measured data sets provided by the measurement component 205 of the device 200, input data provided by the input component 230 of the device 200, pre-processed data sets provided by the pre-processing component 305 of the calculation component 210, nonlinearly transformed data sets provided by the nonlinear calculation component 310 of the calculation component 210, and separated signals provided by the source separation component 315 of the calculation component 210. The post process 320 may also provide scaling, filtering, or other analytical functions.

[00105] In some embodiments, the device 200 may comprise multiple components on, near, adjacent or far from the other components. For example, the output component may be separate from the sensors. The different components can be connected wired or wireless.

[00106] In some embodiments, the device 200 comprises an output component that may output one or more output signals, results, or data. The output may be displayed on a display component 215. The display component 215 may display one or more of numbers, text, instructions, graphs, tables, charts and pictures. The display component 215 may display information related to a blood analyte concentration level and/or information unrelated to a blood analyte concentration level (e.g., the time of day). The display component 215 may display information provided by the calculation component 210. The display component 215 may display a history related to blood analyte concentration levels. The display component 215 may display estimated blood analyte concentration levels as a function of time.

[00107] In some embodiments, the device 200 comprises an adaptation component 220. The adaptation component 220 may comprise a test data component. The test data component may, for example, compare invasively measured or otherwise known blood analyte concentration levels with blood analyte concentration levels estimated from non-invasively measured data sets. The adaptation component 220 may determine parameters, equations and/or other properties related to other components (e.g., the calculation component 210) based on test data and/or information, for example, about the patient, such as the patient's weight. In some embodiments, the adaptation component 220 is only used during initial setup of the device. In some embodiments, the adaptation component 220 is used subsequent to the initial setup. The adaptation component 220 may be used on regular or irregular intervals. The adaptation component 220 may comprise, for example, learning rules.

[00108] In some embodiments, the device 200 comprises a data storage component 225. The data storage component 225 may store, for example, estimated blood analyte concentration levels which may be provided by the calculation component 210. The data storage component 225 may store one or more measured data sets, results, or interim values. The data storage component 225 may store one or more output signals or results. In some embodiments, the data storage component 225 may provide stored data to the calculation component 210. The calculation component 210 may, for example, use the stored data to

calculate average estimated blood analyte concentration levels or trends in the concentration levels. In some embodiments, the data storage component 225 may provide stored data to the display component 215. The display component 215 may, for example, use the stored data to show trends in the concentration levels as a function of time.

[00109] In some embodiments, the device 200 comprises an input component 230. The input component 230 may include a mouse, a keyboard, and/or one or more buttons. The input component 230 may include a responsive screen, such as a touch-sensitive screen. The input component 230 may include an input/output port or an electrical connection. For example, the input component 230 may comprise a USB port. The input component 230 may be configured to receive variables, such as variables measured by another device. The input component 230 may be configured to receive instruction or information from the user, such as a list of food eaten or the time of one or more previous treatments (e.g., insulin injections). The input component 230 may be configured to receive inputs related to the blood analyte concentration level estimations. For example, the inputs may be used to change a parameter and/or equation of a component of the calculation component 210. As another example, inputs may be used to identify concentration level estimates to be averaged (e.g., an input could indicate that all concentration levels within each day be averaged). Inputs may also indicate that it is time for an estimation to be made and/or time for the measurement component 205 to measure one or more physical properties or conditions. Inputs may be used to provide test data to the calibration component 220 comprising, for example, invasively measured variables to the device or may indicate that it is time for a calibration to be performed by the calibration component 220. Inputs may control display settings of the device 200. Inputs may control data stored in the memory of the device 200. In some embodiments, the device 200 comprises a computer.

[00110] In some embodiments, the device 200 can be worn by a patient. The device 200 may comprise, for example, a watch. The device 200 may comprise a band, such as a wrist band or an ankle band. The device 200 may comprise a glove. The device 200 may comprise a patch. In some embodiments, the device 200 continuously estimates a blood analyte concentration level. In some embodiments, the device 200 regularly estimates a blood

analyte concentration level. In some embodiments, the device 200 estimates a blood analyte concentration level after receiving a specific user input.

**[00111]** Computer Implementation

**[00112]** In some embodiments, a method described herein comprises a computer-implemented method. In some embodiments, a system and/or device described herein comprises a computer. In some embodiments, a calculation component of a system and/or device described herein comprises a computer. The computer may comprise a digital signal processor (DSP) or a central processing unit (CPU), one or more peripherals (e.g., RAM, ROM, PROM, or EPROM), and a program to be executed by the DSP or CPU. The computer may comprise an input device, which may be configured to receive data from another device and/or to receive input data from a user. The computer may comprise a user interface for receiving or displaying data and/or information. The computer may comprise an output device, which may be configured to display data and/or information. The program may comprise computer-readable medium comprising instructions for performing a method disclosed herein.

**[00113]** Referring now to Figure 6, a glucose characterization method 350 is illustrated. Generally, glucose characterization process 350 has four steps: first 352, data is collected from the patient and the environment using non-invasive techniques; second 354, a generally linear relationship is provided between the collected data and the glucose level; third 356, a glucose signal is identified from the data set that is indicative of the glucose level; and fourth 58, the glucose signal is scaled and processed for presentation. These steps enable glucose characterization process 350 to present a highly accurate glucose level, even under changing patient or environmental conditions. In this way, process 50 may be implemented in a wider range of applications and environments, and may be used with greater confidence and less pain than previous devices or processes.

**[00114]** In step 352, noninvasive data is collected from the patient 361 or from the environment 363. Typically, data is collected from the patient using noninvasive skin-surface sensors. These sensors may be used to measure electrical, optical, temperature, or humidity characteristics, for example. Some of these characteristics may measure surface

characteristics, while others may indicate characteristics of underlying tissue or fluids. Some of the sensors may be configured to measure an existing property, such as temperature, while other sensors may actively provide a stimulation. For example, some sensors may provide an RF frequency signal for measuring an RF impedance, while other sensors may provide a light signal for measuring an optical property. It will be understood that a wide range of noninvasive sensors may be used. At least some of the data collected from the patient 361 has information that has a known direct relationship with the target physiological parameter as shown by arrow 364. This means, for example, that a change in the glucose level causes a change in that set of data. Other data from the patient and from the environment may have an indirect relationship as shown by arrow 362.

[00115] In a specific example of process 350, RF Impedance data is collected from the patient using a non-invasive sensor. The RF data has a known direct relationship with the glucose level. Other patient data, such as the skin temperature and skin humidity is measured, as well as the pressure between the sensor and the skin. This latter data does not directly indicate any glucose level, but is used for adjusting other aspects of process 350 that provide scaling, calibration, or filtering, for example.

[00116] The RF data 364, which has a known non-linear relationship with the glucose level, is passed through an algorithmic, table, modeling, or other scaling process 365 to adjust the RF data for a more linear relationship. This linearized data is then passed to identification step 356. The linearization process 354 may be determined according to historical data, published data, or learned and adapted over time. In block 356, the linearized data is first separated into independent sources as shown in block 367, and then the signal associated with the glucose level is identified in block 369. Typically, the separation process will be a blind signal source process, for example, an independent component analysis, or may have another signal separation process applied. With the proper signal identified, the glucose signal is scaled 371, typically using the indirect information 362. The scaled glucose level is then presented as shown in block 373.

[00117] Patients

**[00118]** A method and/or system described herein may be used to determine a desired physiological parameter such as blood analyte concentration level of a patient. A system described herein may be provided to a patient. A patient may provide a third party, such as a physician, with a plurality of data sets. The physician may then use a method and/or system described herein to estimate a blood analyte concentration level of the patient. For example, the third party may apply a nonlinear transformation to at least one of the plurality of variables and then employ a source separation process and a post-processing technique to estimate the blood analyte concentration level. In this way, the patient may wear a smaller device constructed to measure and collect data sets of measured physical properties or environmental conditions. When analysis is desired, the data sets are loaded onto a processing device that applies the previously discussed processes. In some embodiments, a kit comprising instructions described herein of estimating a blood analyte concentration level is provided. Accordingly, the particular modules of device 200 may be found on multiple discrete devices.

**[00119]** In some embodiments, a method and/or system described herein estimates a pre-determined blood analyte concentration level, such as glucose. In some embodiments, a method and/or system described herein estimates a plurality of pre-determined blood analyte concentration levels, such as glucose and cholesterol. In some embodiments, a method and/or system described herein screens for potential conditions by estimating a plurality of blood analyte concentration levels. In some embodiments, the patient is healthy.

**[00120]** In some embodiments, the patient suffers from a known condition (e.g., a blood-glucose condition), while in other embodiments, the patient is at risk of suffering from the condition. The patient may be at risk of suffering from the condition due to, for example, a family history, a disease history, a glucose test history (e.g., impaired fasting glucose or impaired glucose tolerance), an insulin condition (e.g., insulin resistance), a weight condition (e.g., obesity), high blood pressure, a cholesterol condition (e.g., HDL cholesterol less than 35 mg/dL or triglyceride levels greater than 250 mg/dL), a metabolic disorder (e.g., polycystic ovary syndrome), being of a specific ethnicity, and/or a blood vessel condition. The condition may be related to a blood analyte concentration level. The condition may be related to an abnormal blood analyte concentration level. The condition may be related to glucose levels.

The condition may be insulin resistance. The condition may be diabetes. The condition may be impaired glucose homeostasis and/or impaired glucose tolerance. In other embodiments, the patient is unaware of a known condition, and the invention method and device is utilized to detect a particular condition.

[00121] The diabetes may be Type 1 or Type 2 diabetes. Type 1 (or insulin-dependent diabetes mellitus or juvenile-onset diabetes), develops when the body's immune system destroys pancreatic cells that make the hormone insulin, which regulates blood glucose levels. Type 1 diabetes usually occurs in children and young adults, although disease onset can occur at any age. Type 1 diabetes accounts for about 5 to 10 percent of all diagnosed cases of diabetes. Risk factors for Type 1 diabetes include autoimmune, genetic, and environmental factors. Type 2 (or Type II) diabetes (non-insulin-dependent diabetes mellitus (NIDDM) or adult-onset diabetes), is a metabolic disorder involving dysregulation of glucose metabolism and insulin resistance, which can result in long-term complications involving the eyes, kidneys, nerves, and blood vessels. Type 2 diabetes results from the body's inability to make either sufficient insulin (abnormal insulin secretion) or its inability to effectively use insulin (resistance to insulin action in target organs and tissues). This disease usually begins as insulin resistance, a disorder in which the cells do not use insulin properly, and as the need for insulin rises, the pancreas gradually loses its ability to produce insulin. Patients suffering from Type 2 diabetes have a relative insulin deficiency. That is, in these patients, plasma insulin levels are normal to high in absolute terms, although they are lower than predicted for the level of plasma glucose that is present. Type 2 diabetes is the most common form of the disease accounting for 90-95% of diabetes.

[00122] The patient may be of any age. The patient may be under the age of 18. The patient may be over the age of 65. The patient may be experiencing or may have experienced one or more of persistently elevated plasma glucose concentration (hyperglycemia); polyuria; polydipsia; polyphagia; chronic microvascular complications such as retinopathy, nephropathy and neuropathy; and macrovascular complications such as hyperlipidemia and hypertension. The patient may be experiencing or may have experienced blindness, end-stage renal disease, limb amputation and myocardial infarction. Any of these symptoms may be a symptom of diabetes.

[00123] The patient may be suffering from or at risk of suffering from gestational diabetes. Gestational diabetes refers to a form of glucose intolerance that is diagnosed in pregnant women. The patient may be pregnant. A percentage (5-10 percent) of women with gestational diabetes have Type 2 diabetes after pregnancy. Women who have had gestational diabetes also have a 20-50 percent chance of developing diabetes in the next 5-10 years. The patient may have recently or previously been pregnant. The patient may be receiving a treatment to treat a condition. The condition may be any condition described herein or any other condition. The treatment may comprise an insulin treatment. The treatment may be administered routinely or on an as-needed basis. The routinely administered treatment may be administered daily. A method and/or system described herein may be used to determine when a treatment should be administered and/or provided to the patient.

[00124] Kits

[00125] In some embodiments, a kit comprises a system and/or device described herein. In some embodiments, a kit comprises a set of instructions providing a method described herein. In some embodiments, a kit comprises a set of instructions related to use of a system and/or device described herein. In some embodiments, a kit comprises a set of instructions related to the interpretation of output from a system, device and/or method described herein. Instructions may indicate how frequently a system, device, and/or method described herein should be used. Instructions may indicate appropriate blood analyte concentration levels. The appropriate blood analyte concentration levels may be determined by standard healthcare knowledge. Instructions may suggest actions when high and/or low blood analyte concentration level estimates are provided by a system, device and/or method described herein. Instructions may indicate proper usage of a system and/or device described herein. For example, the instructions may indicate details related to preferred and/or necessary skin contact with the device. Instructions may suggest when the system and/or device should be calibrated.

[00126] Uses



[00127] In some embodiments, a device and/or a method described herein may be used as part of a treatment for a condition (e.g., diabetes). For example, the device and/or method could provide data useful in determining a dosage of a drug that should be administered or a time when a drug should be administered. In some embodiments, a device and/or a method described herein may be used as part of a dietary regimen and/or a weight loss program. The dietary regimen and/or the weight loss program may be related to a health-related condition. For example, the device and/or method may be used by a patient with high cholesterol. The device and/or method may then indicate when, for example, it is recommended that a patient intake or not intake a particular type of food. In some embodiments, a device and/or a method described herein may be used as an information source by a medical professional. For example, the device and/or method may provide a means by which a doctor can monitor a patient's glucose levels between visits. In such embodiments, estimated glucose levels may, for example, be sent to the medical professional via a network connection. As another example, estimated blood analyte concentration levels may be analyzed across patients. Such analysis may suggest particular causes of specific levels, pre-dispositions to specific levels, effective treatments, and/or trends in patients' health.

[00128] Example 1

[00129] *Data Measurement.* Various sensors to monitor different physiological properties were used to acquire information about patients by generating one or more data sets. Both healthy and patients with diabetes were tested, although other patients could be easily tested. Different information was acquired using multiple sensors on the skin, particularly the forearm. Although the forearm was tested, the sensors could be placed on different parts of the body or on one discrete point. Eventually, as non-contact sensors are developed, they can be placed adjacent to the skin, although direct contact with the skin is preferred. The measurement data included RF (radio frequency) impedance in conjunction with the temperature (skin and device), humidity and pressure between skin and device. The RF impedance is a primary signal of interest, but environmental conditions such as temperature and humidity also used to calibrate personal and environmental changes.

[00130] Information that was acquired at the point of contact(s) was the dielectric properties of the skin and the underlying tissue, pressure, temperature, moisture and blood perfusion, although other physiological measurements have been taken as well including pulse and other cardiovascular information, and the like. Impedance information was acquired using a depth selective electrical impedance spectrometer (e.g., dielectric spectroscopy based differential sensor, bioimpedance analyzers such as Quantum X™ (RJL Systems, Inc., Clinton Twp., MI), HYDRA ECF/ICF 4200 Bio-Impedance Spectrum Analyzer (Xitron Technologies, Inc., San Diego, CA), SciBase II spectrometer (SciBase AB, Huddinge, Sweden), Solianis spectrometer (Solianis AG, Zurich Switzerland), Fusion XS™ Spectrometer (Biopeak Corp, Ottawa, Canada), and the like). Other physiological signals were also acquired, for example, temperature from infrared temperature sensor, piezoelectric sensor to detect pressure and an optical sensor to measure perfusion or capillary blood flow (e.g., laser Doppler flowmetry – Periflux™ Pf2 (Perimed AB, Stockholm, Sweden)).

[00131] *Linear Processing.* Empirically it is found that the RF measurement data is in nonlinear relationship with the glucose level, and the nonlinearity needs to be reduced before linear prediction stage. This linear processing step nonlinearly transforms or adapts the RF data such that the transformed data set has a more linear relationship with the glucose level. For the purpose of providing a more linear relationship between the measured data and the glucose level, we use a 1D mapping function  $f(\cdot)$ , to compute preprocessed signal Y.

$$[00132] \quad y_i = f(x_i) \quad (\text{Eq. 2})$$

$$[00133] \quad \text{Where } X = [x_1, \dots, x_n], Y = [y_1, \dots, y_n]$$

[00134] Specifically in this example, we use a function that scales the signal nonlinearly in order to adjust the data set so that it has a more linear relationship with glucose levels. It will be understood that after the linearization process, the resulting relationship is not fully linear, but is a more linear relationship than prior to the transformation. As more data is collected and analyzed, other functions, tables, or algorithms may be used to provide enhanced linearity. Different mapping functions can be designed for each of data dimensions. Examples of such nonlinear scaling functions are:

- [00135]  $f(x) = a x^b + c$ ;
- [00136]  $f(x) = \cosh(x)$ ;
- [00137]  $f(x) = 1/(1+\exp(-x))$ ; and
- [00138]  $f(x) = \log(x)$ .

[00139] Another non-linear mapping function is illustrated in Figure 7. It will be appreciated that look-up tables, models, or other transformation processes may be used.

[00140] *Independent Source Separation.* From the transformed test data set, we can compute a linear mapping  $z$  which should be highly correlated with the glucose level and be robust to personal and environmental changes. ICA (Independent Component Analysis) is an algorithm that identifies linear subspace of independent components from a set of input signals. When applied to the transformed signal, ICA finds number of subspaces of which signals are independent of each other. ICA is able to identify linear components which are independent of each other. The pre-processed RF impedance signal is linearly correlated with the glucose level, but is highly contaminated with the other noisy factors. Since ICA can extract original signal from multi-dimensional observation signals mixed with high noise, we can find cleaner signals which shows higher correlation with the glucose level. The component 1(Z1) of the ICA source signals shows high correlation with the original glucose levels. Figure 9 (A) and (B) show the comparison of ICA source signal Z1 with the true glucose level measured by invasive method. The ICA source Z1 shows high correlation coefficient (0.87). While the input data X shows minimal correlation in Figure 8.

[00141] *Post-Processing.* After the glucose predictor is computed, we compensate the scale and offset of the value to be matched with standard glucose level by equation (3).

$$[00142] \quad G = c Z1 + \text{offset} \quad (\text{Eq. 3})$$

[00143] The calibration constant  $c$  and offset can be estimated using small number of actual glucose level measurements. Figure 9 (C) shows the final estimated glucose level  $G$  which shows high correlation with the true glucose level of figure 6 (A).

**[00144]** Example 2

**[00145]** In a second example, multiple sets of RF data were collected. Several sets of RF data were collected, with each set representing impedance at a different skin depth. In another example, each set represents RF impedance measured at a different frequency, or using a different signal shape, under different positions or placements of the sensors, or over a period of time. Several datapoints of blood analyte information can be analyzed over a period of time because gradual changes typically occur over several minutes. In this way, example 2 uses multiple sets of the same type of data, with each data set having a known direct relationship with glucose or another target physiological parameter. By using multiple sets of the same type of data, reliance on other indirect data may be eliminated or reduced.

**[00146]** Example 3

**[00147]** In a third example, multiple sets of direct data are collected. For example, a set of RF data may be collected, and a set of infrared data may be collected. In this way, example 3 uses multiple sets of different direct data, with each data set having a known direct relationship with glucose or another target physiological parameter. By using multiple sets of direct data, reliance on other indirect data may be eliminated or reduced. It will be understood that many different types of direct data sets may be substituted or used. For example, direct data may include RF impedance data, near infrared data, far infrared data, polarization data, or fluorescence data, for example. By using multiple direct data sets, increased accuracy and reliability may be obtained, while reducing reliance on other indirect data measurements. Figure 10 generally shows such a process. Process 450 is similar to processes 50 and 350 previously described, so will not be discussed in detail. In characterization process 450, only data having a direct relationship with the physiological parameter is collected, as shown in block 461. However, multiple sets are collected. In one example, the multiple sets represent different collections of the same type of data (eg all RF impedance data, but at different skin depths). In another example, the multiple sets each represent different types of data (eg, one set of RF impedance data and one set of infrared

data). In yet another example, some data sets may have different collections of the same type of data, and other data sets may have different types of data. It will be understood that a wide range of direct data types and collection specifics are possible. In block 466, it is determined if each data set has a linear relationship with the target physiological parameter. If so, the data is passed to the identification process, and if not, each non-linear data set is linearized using one or more algorithms/tables/models 465. The generally linear data is received into the separation process 467. It will be understood that a single separation process may be used, where each of the linear data sets becomes an input signal to a single process, or that multiple separation processes may be used. The identified signal or signals are scaled and presented.

**[00148]** While the above detailed description has shown, described, and pointed out novel features of the invention as applied to various embodiments, it will be understood that various omissions, substitutions, and changes in the form and details of the device or process illustrated may be made by those skilled in the art without departing from the spirit of the invention. The scope of the invention is indicated by the appended claims rather than by the foregoing description. All changes which come within the meaning and range of equivalency of the claims are to be embraced within their scope.

WHAT IS CLAIMED IS:

1. A method for estimating a concentration level of a blood analyte, comprising:  
non-invasively measuring a plurality of variables in a patient to obtain a set of input data;  
nonlinearly filtering at least part of the set of input data to obtain a set of filtered data;  
and  
applying a source separation method to the set of filtered data to obtain a set of output data,  
wherein at least one first variable of the plurality of variables depends on the patient's blood analyte concentration level, and  
wherein at least one second variable of the plurality of variables does not depend on the patient's blood analyte concentration level.
2. The method of Claim 1, wherein the blood analyte comprises glucose.
3. The method of Claim 1, wherein the source separation method is at least partially adaptive.
4. The method of Claim 1, wherein the nonlinearly filtering comprises an at least partially adaptive component.
5. The method of Claim 1, wherein the at least one first variable comprises a variable selected from electrical impedance variable, a capacitance variable, and a current variable.
6. The method of Claim 1, wherein the at least one first variable comprises an electrical impedance variable.
7. The method of Claim 1, wherein the at least one first variable comprises an impedance spectroscopy variable.

8. The method of Claim 1, wherein the at least one first variable comprises a skin capacitance variable.
9. The method of Claim 1, wherein the at least one first variable depends on the at least one second variable.
10. The method of Claim 1, wherein the plurality of variables comprises a variable selected from skin temperature, body temperature, air temperature, skin moisture, blood flow, blood pressure, a hydration variable, an ECG variable, an EEG variable, a skin-device pressure variable, device movement, atmospheric pressure, an oxygen saturation variable, and humidity.
11. The method of Claim 1, wherein the plurality of variables comprises the time of day.
12. The method of Claim 1, wherein the non-invasively measuring comprises emitting at least one pair of wavelengths from an energy source towards a first selected area of the patient and detecting energy emerging from a second selected area of the patient.
13. The method of Claim 12, wherein the at least one pair of wavelengths is within the range of about 600 to about 1 millimeter;
14. The method of Claim 1, further comprising invasively measuring a variable dependent on the blood analyte.
15. The method of Claim 14, further comprising comparing the invasively-measured variable to at least one of the plurality of variables.
16. The method of Claim 14, further comprising comparing the invasively-measured variable to at least one variable of the set of filtered data.
17. The method of Claim 14, further comprising comparing the invasively-measured variable to at least one variable of the set of output data.

18. The method of Claim 1, wherein the source separation method comprises at least one of an Independent Component Analysis (ICA) and an Independent Vector Analysis (IVA) method.
19. A non-invasive blood-analyte-monitoring apparatus, comprising:  
an analyte-sensitive measuring component configured to measure an analyte -sensitive variable related to a concentration level of the blood analyte in a patient;  
an analyte-insensitive measuring component configured to measure an analyte -insensitive variable not related to the concentration level of the blood analyte in the patient;  
an analyte calculation component comprising a nonlinear calculation component that is configured to nonlinearly filter at least one variable, and  
wherein the analyte calculation component is configured to receive the analyte-sensitive and analyte-insensitive variables as inputs and calculate the patient's estimated blood analyte concentration level.
20. The apparatus of Claim 19, wherein the blood analyte comprises glucose.
21. The apparatus of Claim 19, wherein the analyte calculation component is at least partially adaptive.
22. The apparatus of Claim 19, wherein the analyte-sensitive variable comprises a variable selected from electrical impedance variable, a capacitance variable, and a current variable
23. The apparatus of Claim 19, wherein the analyte-sensitive variable comprises an impedance variable.
24. The apparatus of Claim 19, wherein the analyte-insensitive variable comprises a variable selected from skin temperature, body temperature, air temperature, skin moisture, a hydration variable, a skin-device pressure variable, atmospheric pressure, device movement and humidity.



25. The apparatus of Claim 19, wherein the analyte-sensitive measuring component comprises at least one electrode.
26. The apparatus of Claim 19, further comprising a stimulus-delivering component.
27. The apparatus of Claim 19, further comprising a temperature-measuring component.
28. The apparatus of Claim 19, further comprising a pressure-measuring component.
29. The apparatus of Claim 19, further comprising an optical sensor.
30. The apparatus of Claim 24, wherein the stimulus-delivering component comprises at least one electrode.
31. The apparatus of Claim 19, wherein the nonlinearly filtering comprises taking the logarithm of the at least one variable.
32. The apparatus of Claim 19, wherein the analyte calculation component comprises a blind source separation module, configured to separate at least two signals.
33. The apparatus of Claim 32, wherein the blind source separation module comprises at least one of an Independent Component Analysis (ICA) module and an Independent Vector Analysis (IVA) module.
34. The apparatus of Claim 19, further comprising a display component.
35. The apparatus of Claim 31, wherein the display component is configured to display the patient's estimated blood analyte concentration level.
36. The apparatus of Claim 19, further comprising a data storage component.
37. The apparatus of Claim 36, wherein the data storage component stores estimated blood analyte concentration level data.

38. The apparatus of Claim 37, further comprising a display component configured to display the patient's estimated blood analyte concentration level as a function of time.
39. The apparatus of Claim 19, wherein the apparatus comprises a watch.
40. A method for estimating a blood-analyte concentration level in a patient, comprising:  
receiving a first set of input variables,  
wherein the first set of input variables do not comprise any invasively-measured variables,  
wherein at least one first variable of the first set of input variables is influenced by the patient's blood analyte concentration level, and  
wherein at least one second variable of the first set of input variables is not influenced by the patient's blood analyte concentration level;  
pre-processing at least one of the first set of input variables to produce a second set of variables; and  
applying a linear separation method to the second set of variables produce a third set of variables.
41. The method of Claim 40, wherein the blood analyte comprises glucose.
42. The method of Claim 40, wherein the pre-processing at least one of the first set of input variables comprises nonlinearly transforming at least one of the first set of input variables.
43. The method of Claim 40, wherein the pre-processing at least one of the first set of input variables is at least partially adaptive.
44. The method of Claim 40, wherein the linear separation method comprises a blind source separation method.
45. The method of Claim 40, wherein the linear separation method is at least partially adaptive.

46. The method of Claim 40, wherein the blind source separation method comprises at least one of an Independent Component Analysis (ICA) and an Independent Vector Analysis (IVA) method.
47. The method of Claim 40, further comprising post-processing at least one of the third set of variables.
48. The method of Claim 40, further comprising determining the nonlinear transform by using test data comprising both non-invasively measured variables and invasively measured variables.
49. The method of Claim 40, further comprising determining the nonlinear transform by using a neural network to relate test data comprising non-invasively measured variables to test data comprising invasively measured variables.
50. The method of Claim 40, further comprising determining parameters of the linear separation method by using test data comprising both non-invasively measured variables and invasively measured variables.
51. The method of Claim 40, further comprising determining parameters of the linear separation by using a neural network to relate test data comprising non-invasively measured variables to test data comprising invasively measured variables.
52. The method of Claim 40, wherein the method is a computer-implemented method.
53. A method for characterizing a target physiological parameter, comprising:  
collecting a first data set of data from a patient, the first data set having a direct relationship with the target physiological parameter;  
collecting a second data set;  
processing the first data set so that the processed first data set has a generally linear relationship with the target physiological parameter;  
separating the processed first data set into independent signals;

identifying a parameter signal having the target physiological parameter as its source;  
scaling the parameter signal according to the second data set; and  
presenting the scaled parameter.

54. The method according to claim 53, wherein collecting the first data set further comprises using an optical, electrical, RF, infrared sensor, or impedance sensor.
55. The method according to claim 53, wherein collecting the second data set is a set of data having a direct relationship with the target physiological parameter.
56. The method according to claim 53, wherein collecting the second data set is a set of data having an indirect relationship with the target physiological parameter.
57. The method according to claim 53, wherein collecting the second data set is a set of data having a direct relationship with the target physiological parameter.
58. The method according to claim 53, wherein collecting the second data set is from a patient and is indicative of a physiological parameter.
59. The method according to claim 53, wherein collecting the second data set is from a patient and is not indicative of a physiological parameter.
60. The method according to claim 53, wherein collecting the second data set is indicative of an environmental condition.
61. The method according to claim 53, wherein the first data set has a generally linear relationship with the target physiological parameter so that the processing step does not change data values in the first data set.
62. The method according to claim 53, wherein the processing step comprises determining that the first data set has a generally linear relationship with the first data set.

63. The method according to claim 53, wherein the processing step comprises determining that the first data set has a generally non-linear relationship with the first data set.
64. The method according to claim 53, wherein the processing step comprises applying an algorithm or table to the first data set to generate the processed data set.
65. The method according to claim 53, wherein the separation process is a blind signal separation process or an independent component analysis process.
65. The method according to claim 53, wherein the separation process is a blind signal separation process or an independent component analysis process.
66. The method according to claim 53, wherein the separation step is adapted according to the second data set.
67. The method according to claim 53, wherein the identification step is adapted according to the second data set.
68. The method according to claim 53, wherein the scaling step is adapted according to the second data set.
69. The method according to claim 53, wherein the presenting step comprises visually displaying, audibly projecting, setting an alarm, sounding an alarm, communicating a message, or activating another device.
70. The method according to claim 53, wherein the target physiological parameter is selected from the group consisting of: blood analyte, cancer detection, heart condition,

hydration, fat composition, tissue characterization, blood flow / pressure, electrolyte, fat, hemoglobin, lactic acid, oxygen saturation, and respiration

71. A glucose monitor, comprising:  
A housing;  
a non-invasive sensor collecting RF impedance data;  
another sensor collecting other patient data;  
a display in the housing for presenting a measured glucose level; and  
a processor in the housing for operating the steps of:  
receiving the set of RF impedance data;  
linearizing the RF impedance data to glucose;  
separating the linearized data using a blind signal source algorithm;  
identifying a glucose signal;  
scaling the glucose signal according to the other patient data; and  
presenting the scaled glucose signal as the measured glucose level.
72. The glucose monitor according to claim 71, wherein the non-invasive sensor is in the housing.
73. The glucose monitor according to claim 71, wherein the other sensor is in the housing.
74. The glucose monitor according to claim 71, wherein the non-invasive sensor is in the housing.

75. The glucose monitor according to claim 71, wherein the other data is skin temperature, skin humidity, pressure between the non-invasive sensor and the skin, or ambient temperature.

76. glucose monitor according to claim 71, wherein the processor further uses the other data to filter noise from the RF impedance data.

1/7

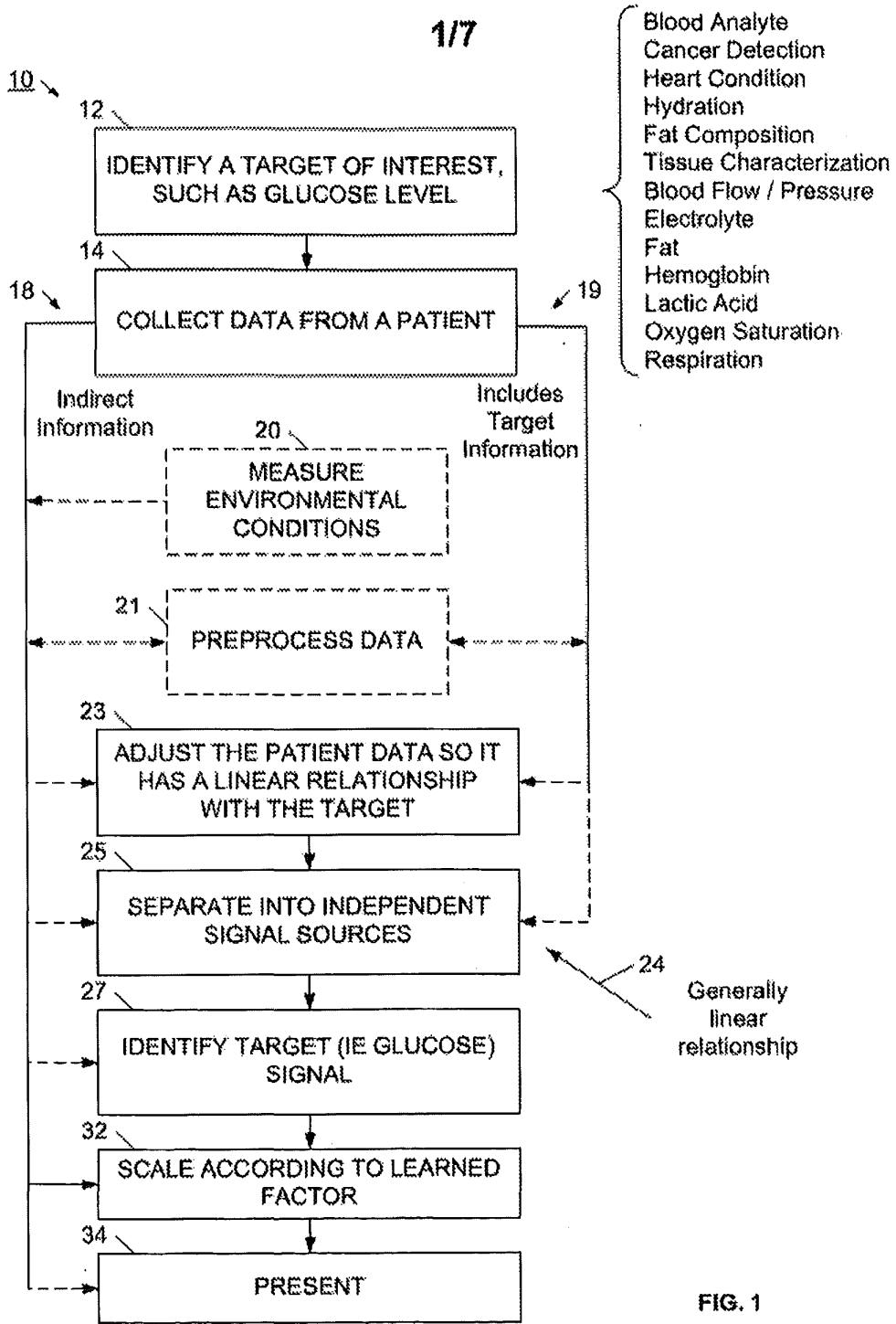

FIG. 1



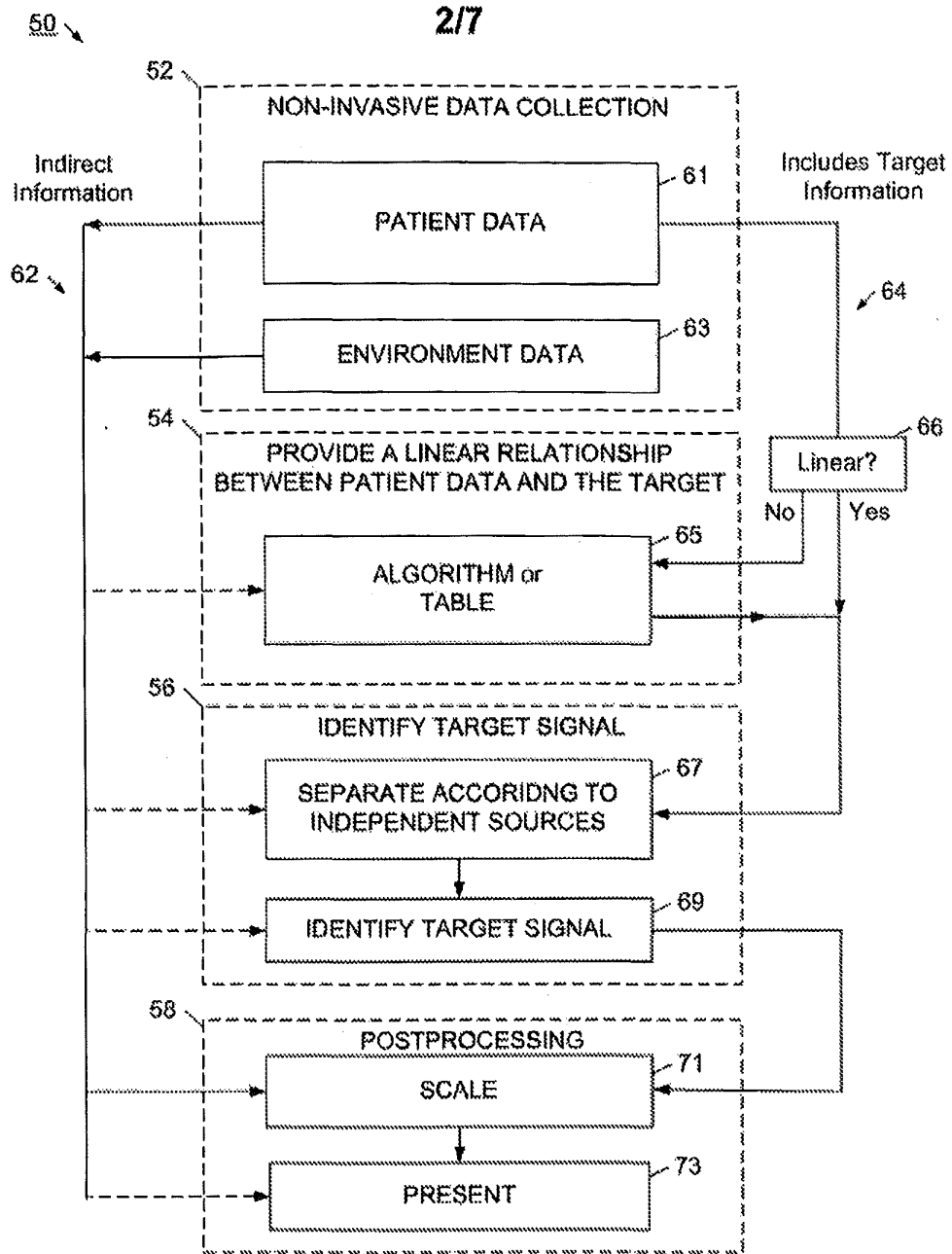

FIG. 2

3/7

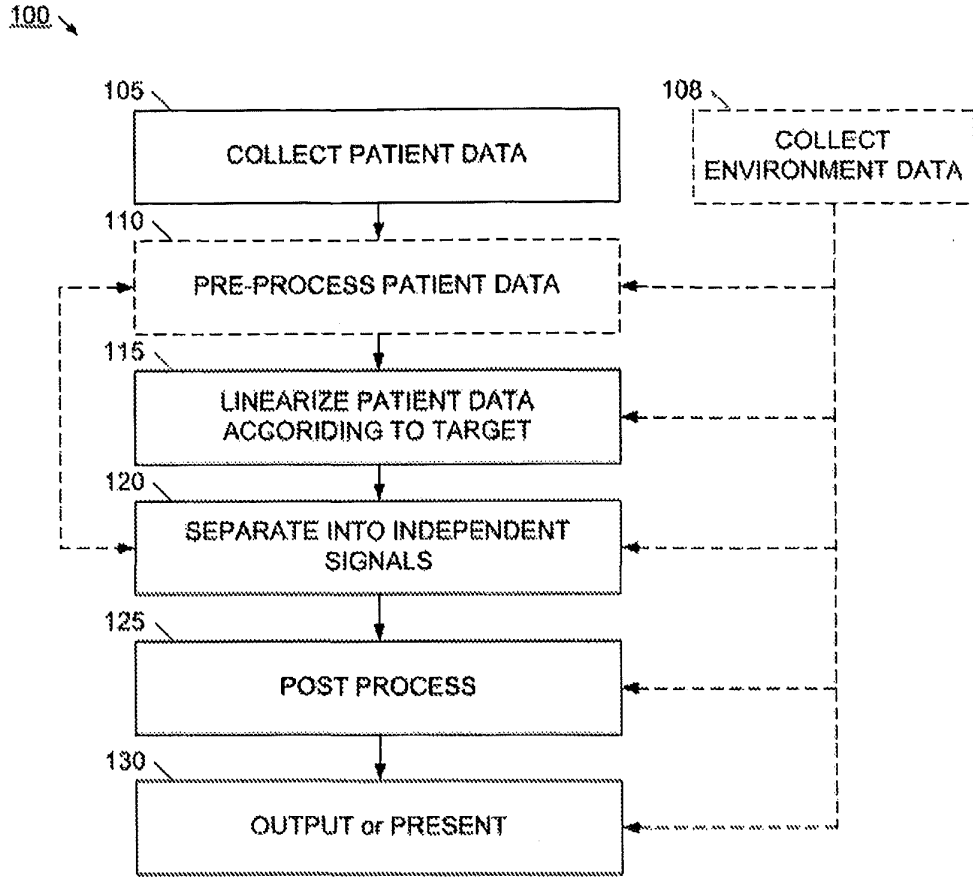

FIG. 3

4/7

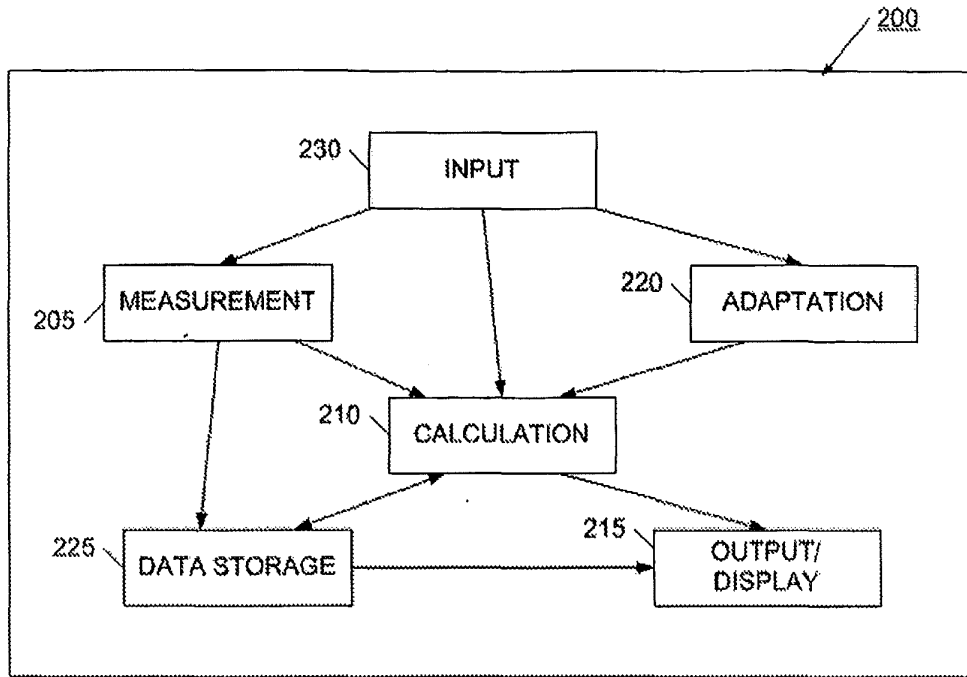

FIG. 4

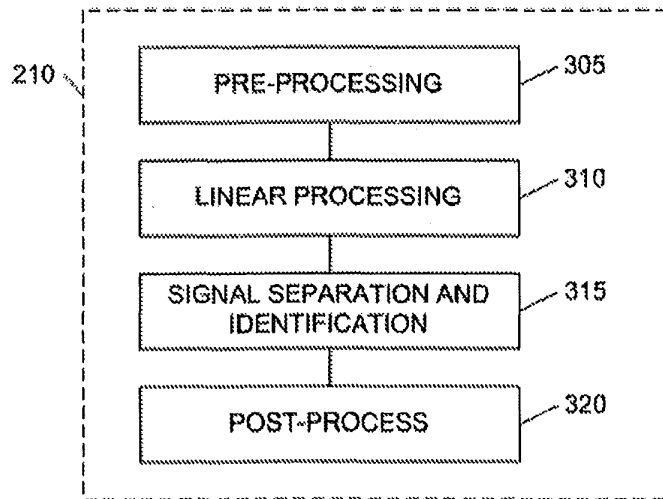

FIG. 5

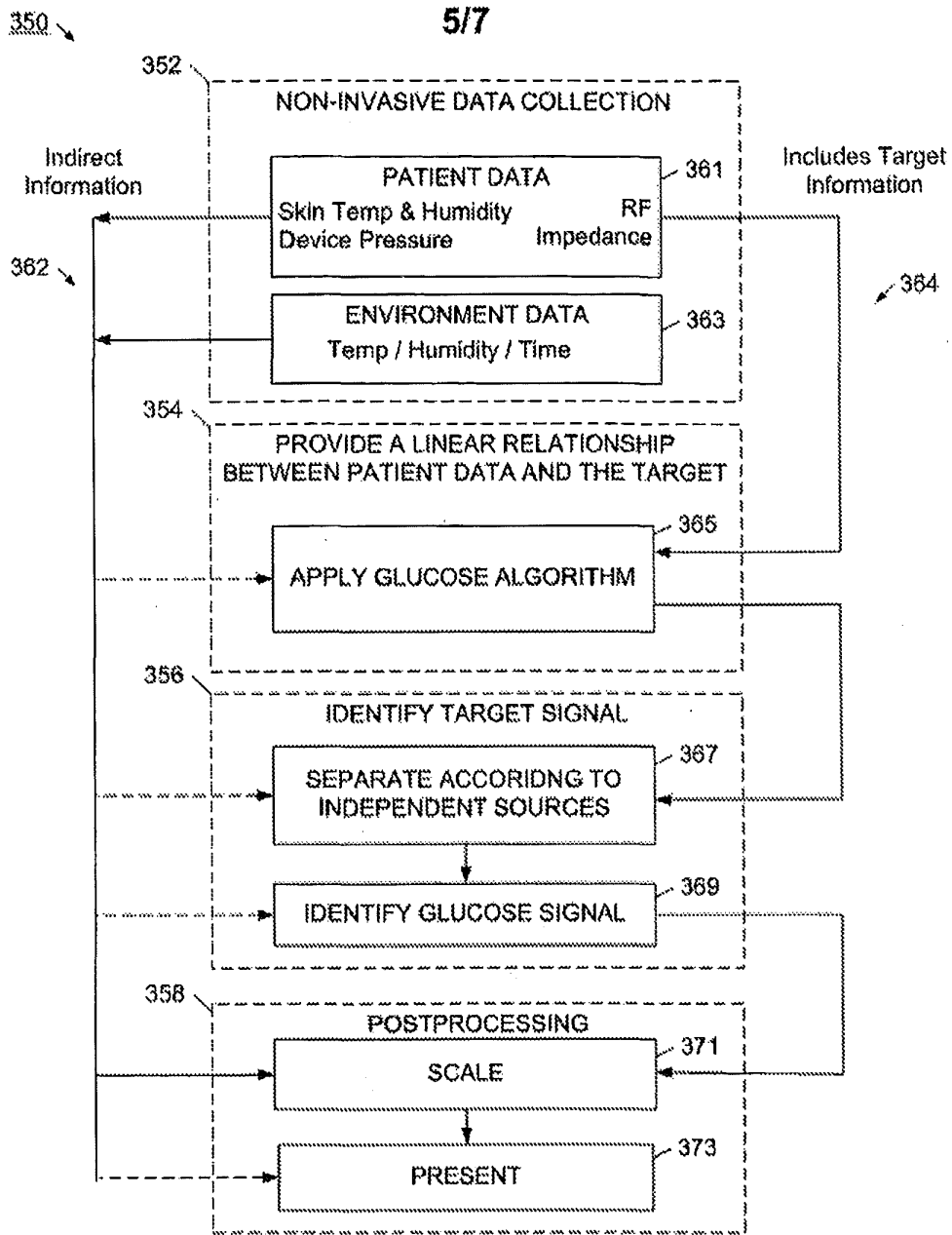

FIG. 6

6/7

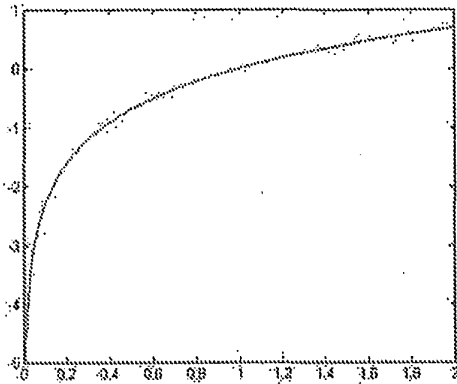

FIG. 7

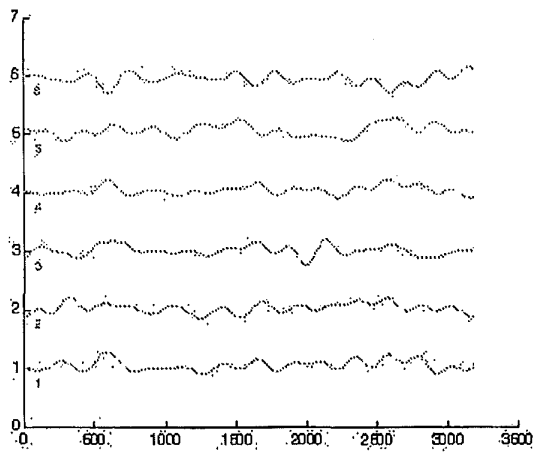
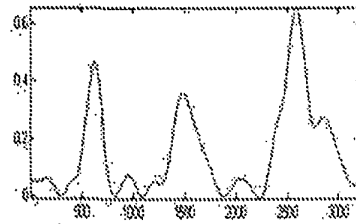
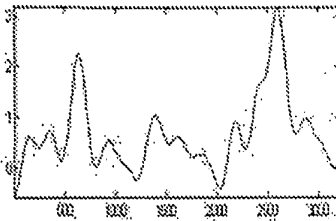

FIG. 8

(A) True Glucose Level



(B) Z<sub>1</sub>



(C) G

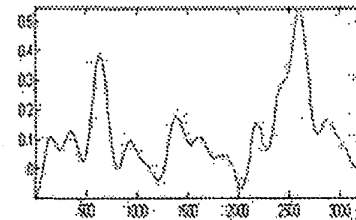

FIG. 9

450 ↙

717

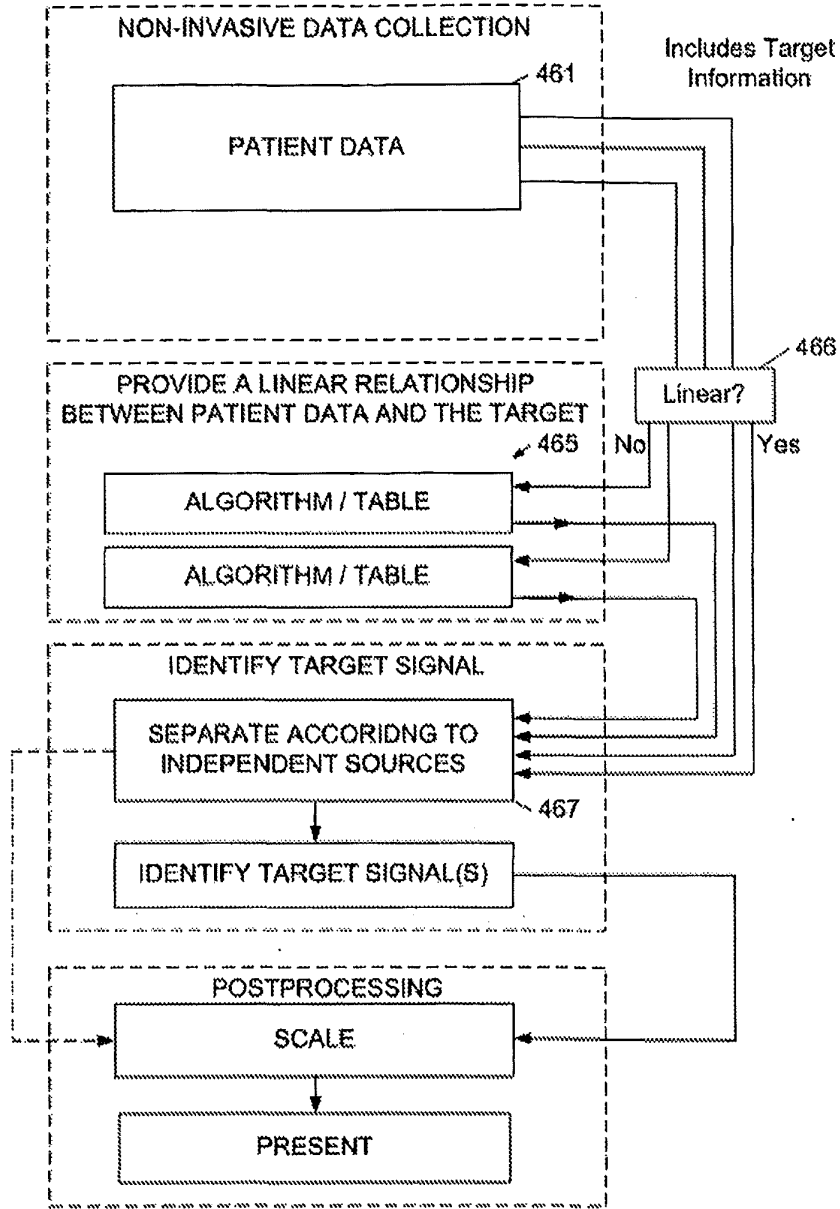

FIG. 10

(19) World Intellectual Property Organization  
International Bureau



(43) International Publication Date  
3 March 2005 (03.03.2005)

PCT

(10) International Publication Number  
WO 2005/020121 A1

- (51) International Patent Classification<sup>7</sup>: G06F 19/00
- (74) Agent: L & K PATENT FIRM; 701, Daekun Bldg., 822-5, Yeoksam-Dong, Kangnam-Gu, Seoul 135-080 (KR).
- (21) International Application Number: PCT/KR2003/001921
- (81) Designated States (national): AE, AG, AL, AM, AT, AU, AZ, BA, BB, BG, BR, BY, BZ, CA, CH, CN, CO, CR, CU, CZ, DE, DK, DM, DZ, EC, EE, EG, ES, FI, GB, GD, GE, GH, GM, HR, HU, ID, IL, IN, IS, JP, KE, KG, KP, KZ, LC, LK, LR, LS, LT, LU, LV, MA, MD, MG, MK, MN, MW, MX, MZ, NI, NO, NZ, OM, PG, PH, PL, PT, RO, RU, SC, SD, SE, SG, SK, SL, SY, TJ, TM, TN, TR, TT, TZ, UA, UG, US, UZ, VC, VN, YU, ZA, ZM, ZW.
- (22) International Filing Date: 19 September 2003 (19.09.2003)
- (25) Filing Language: Korean
- (26) Publication Language: English
- (30) Priority Data: 10-2003-0058062 21 August 2003 (21.08.2003) KR
- (84) Designated States (regional): ARIPO patent (GH, GM, KE, LS, MW, MZ, SD, SL, SZ, TZ, UG, ZM, ZW), Eurasian patent (AM, AZ, BY, KG, KZ, MD, RU, TJ, TM), European patent (AT, BE, BG, CH, CY, CZ, DE, DK, EE, ES, FI, FR, GB, GR, HU, IE, IT, LU, MC, NL, PT, RO, SE, SI, SK, TR), OAPI patent (BF, BJ, CF, CG, CI, CM, GA, GN, GQ, GW, ML, MR, NE, SN, TD, TG).
- (71) Applicant (for all designated States except US): HEALTHPIA CO., LTD. [KR/KR]; 2-102 Medical Instrument Industry Park, 1720-26 Taejang-dong, Wonju-si, Kangwon-do 220-120 (KR).
- (72) Inventor; and
- (75) Inventor/Applicant (for US only): LEE, Min-Hwa [KR/KR]; 11-105 Hyundai Apt., Apgujeong-Dong, Gangnam-Gu, Seoul 135-110 (KR).

Published: — with international search report

[Continued on next page]

(54) Title: HEALTH GAME APPARATUS AND METHOD USING VITAL SIGNS

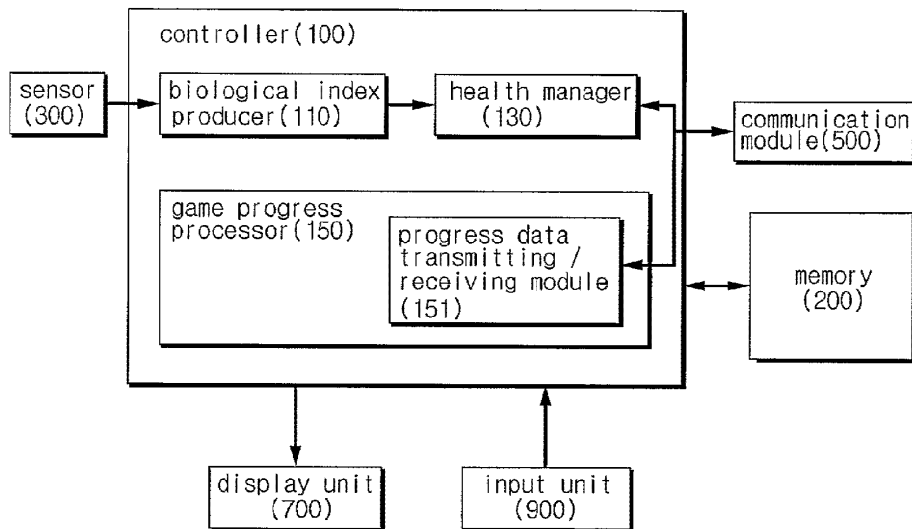

(57) Abstract: A health game apparatus produces, as a numerical value, a quantized biological index associated with a biological function or state from an electrical signal measured by a sensor detecting a biological signal, and considers the produced biological index to progress a game. The health game apparatus can conveniently perform a data input as data is directly inputted from the sensor and allow health management to be interestingly and continuously achieved through a game element coupled to the health management. The health game apparatus allows a host computer to manage the produced biological index and to manage game progress according to data inputted from a plurality of health game apparatuses. Thus, the health game apparatus enables persons having the same health problem to naturally form a community and enables health management to be interestingly performed in addition to an interest in the game.

WO 2005/020121 A1

**WO 2005/020121 A1**



---

*For two-letter codes and other abbreviations, refer to the "Guidance Notes on Codes and Abbreviations" appearing at the beginning of each regular issue of the PCT Gazette.*



## HEALTH GAME APPARATUS AND METHOD USING VITAL SIGNS

## Technical Field

5           The present invention relates to a game apparatus,  
and more particularly to a health game apparatus capable of  
being used to manage health of a user.

## Background Art

10

In the specification, the term "health" represents a  
generic concept including disease, beauty, etc. Furthermore,  
the term "health management" represents a generic concept  
including disease-related management such as blood glucose  
15 management, blood pressure management, liver function  
management, kidney function management, etc. and beauty-  
related management such as obesity management, skin  
management, etc.

20           When organs such as the liver, the kidney, etc. are  
damaged, it is not easy to prevent the damaged organs from  
deteriorating further. Thus, patients must continuously pay  
attention to their bodies while moderately dieting or  
exercising and monitoring their body states. Similarly,  
there is an interest in reducing a person's weight and  
25 maintaining a non-smoking habit as well as the blood glucose

management and the blood pressure management.

Patients can conveniently monitor their blood glucose levels using portable glucose meters. Further, they can conveniently monitor their blood pressure states through  
5 blood pressure monitors for use in a general home, or through advanced portable blood-pressure monitors for measuring blood pressure based on a speed of blood globules. In a case of reducing body weight, they can conveniently confirm their body states using an apparatus for measuring the amount of  
10 body fat using a bio-impedance analysis technique that is disclosed in Korean Patent Application No. 2002-0052994.

Health or beauty management may be continuously conducted through a monitoring or measurement operation. Furthermore, it is important that continuous stimulation be  
15 given to a user so that the user can perform rigid self-management according to the given continuous stimulation. The health or beauty management method is disclosed in "BACKGROUND OF THE INVENTION" of Korean Patent Publication No. 2002-54075 filed in name of Min-Hyuk Choi. According to  
20 technology disclosed in Korean Patent Publication No. 2002-54075, a diet program is interworked with an online game, and the online game is differently performed according to caloric intake and an amount of exercise inputted by the user.

This idea can improve diet management through  
25 interworking the diet management with an interesting online

game. However, there is a problem in that the user must manually input data of food intake and hence the user feels inconvenience of the manual data input. This technology is limited to the diet program. When the online game associated with the above-described technology is compared with the existing online game, only types of data are different. Consequently, the online game associated with the diet management is not technically improved in comparison with the existing online game. In other words, the above-described technology is only one type of online game.

The inventor has studied portable biological measuring devices such as an ultrasound scanner, a glucose meter, a bio-impedance analysis device, etc. for a long time. As a result, it has been found that self-health management can be effectively performed if a measuring device coupled to an online or offline game can be appropriately implemented.

#### Disclosure of the Invention

Therefore, the present invention has been made in view of the above background, and it is one object of the present invention to provide a health game apparatus and method using the same, which can interestingly and continuously promote health management.

It is another object of the present invention to

provide a health game apparatus and method using the same, which allows biological data necessary for health management to be conveniently inputted.

5                   Brief Description of the Drawings

The above and other objects, features and other advantages of the present invention will be more clearly understood from the following detailed description taken in  
10                   conjunction with the accompanying drawings, in which:

FIG. 1 is a schematic diagram illustrating a health game system including health game apparatuses 10-1, 10-2 and 10-3 and a host computer 30 in accordance with the present invention;

15                   FIG. 2 is a schematic block diagram illustrating the configuration of a health game apparatus in accordance with one embodiment of the present invention;

20                   FIG. 3 is a schematic flow chart illustrating a processing operation performed by the health game apparatus and a host computer communicating with the health game apparatus in accordance with another embodiment of the present invention;

25                   FIG. 4 is a schematic block diagram illustrating a health game apparatus in accordance with another embodiment of the present invention; and

FIG. 5 is a schematic flow chart illustrating a processing operation performed by the health game apparatus and a host computer communicating with the health game apparatus in accordance with another embodiment of the present invention.

#### Best Mode for Carrying Out the Invention

In accordance with an embodiment of the present invention, the above and other objects can be accomplished by the provision of a health game apparatus serving as a terminal based on an online or offline operation, which can produce, as a numerical value, a quantized biological index associated with a biological function or state from an electrical signal measured by a sensor detecting a biological signal or vital sign, and consider the produced biological index to progress a game.

In accordance with the present invention, the health game apparatus can conveniently perform a data input as data is directly inputted from the sensor and allow health management to be interestingly and continuously achieved through a game element coupled to the health management.

In accordance with another embodiment of the present invention, a health game apparatus communicates with a host computer and the host computer manages a biological index

produced from a measurement value. The host computer manages game progress according to data inputted from a plurality of health game apparatuses so that a game can be a multiparty game. The health game apparatus enables  
5 persons having the same health problem to naturally form a community and enables health management to be interestingly achieved in addition to an interest in a game.

In accordance with the present invention, the term "game" includes not only various games such as competition  
10 games, simulation games, etc. but also various contents having interesting elements such as Internet cafes, Internet meetings, etc.

Furthermore, the health game apparatus in accordance with the present invention allows users to form groups and  
15 its function can be extended to support a competition game between the groups. For example, where a user does not individually compete with another user but a user group competes with another user group in a game for reducing body weight, the spirit of teamwork within the group is  
20 naturally made to promote an active motive of reducing the body weight.

In accordance with another embodiment of the present invention, a game character is shown in a game, and the  
game character assigned on a user-by-user basis is  
25 differently displayed according to a measured biological

index. For example, if the health management is successfully and continuously achieved during a predetermined time, a good color of the face or good dress is assigned to the game character. Otherwise, a bad color of the face or bad dress is assigned to the game character. 5 Alternatively, if the health management is successfully and continuously achieved during a predetermined time, an item capable of being used in the game is assigned according to the degree of success, and hence a corresponding user 10 having the assigned item can be in an advantageous position in the game.

In accordance with the present invention, the health game apparatus can give an incentive to users so that rigid health management is promoted, and can visually display 15 health states of the users, such that the users can actively perform the health management.

Now, preferred embodiments of the present invention will be described in detail with reference to the annexed drawings so that those skilled in the art can easily 20 understand the present invention.

FIG. 1 is a schematic diagram illustrating a health game system including health game apparatuses 10-1, 10-2 and 10-3 and a host computer 30 in accordance with the present invention. The health game apparatuses 10-1, 10-2 25 and 10-3 and the host computer 30 communicate with each other

through a data communication network such as a mobile communication network as an example. However, the present invention is not limited to the data communication network. In place of the data communication network, the present invention can employ an Internet network coupled over a wireless local area network (LAN) access point or a Bluetooth access point as another example.

In accordance with one embodiment of the present invention, the health game apparatuses 10-1, 10-2 and 10-3 are portable health game apparatuses equipped with sensors used for measuring health data. In accordance with another embodiment of the present invention, the health game apparatus can include, for example, a battery pack in which a sensor for inputting health data is embedded and a mobile-phone main body interfaced with the battery pack. For example, the battery pack includes a printed circuit board in which a glucose meter circuit is embedded. The printed circuit board performs a communication operation through a recommended standard (RS)-232 or universal serial bus (USB) interface provided in the mobile-phone main body. As other elements, four electrodes necessary for measuring bio-impedance and a measuring circuit are embedded in the battery pack, and a controller for controlling the circuit is interfaced with the mobile-phone main body. The health game apparatuses utilize user interfaces of the mobile phone such



as a keypad, a liquid crystal display (LCD) and can provide various functions only through the replacement of the battery pack while reducing the economic burden.

5 The host computer 30 can be configured by one or more server computers. The host computer 20 includes a world wide web/Windows address book (WEB/WAB) server for processing user access, and a game progress sever interworked with the WEB/WAB server for progressing a game.

10 However, the present invention is not limited to the above-described server-based service. For example, the health game apparatus manages health data. Furthermore, the health game apparatus is interworked with the health data and can provide a game while considering biological data inputted from the sensor in real time.

15 FIG. 2 is a schematic block diagram illustrating the configuration of a health game apparatus in accordance with one embodiment of the present invention. As shown in FIG. 2, the health game apparatus in accordance with the one embodiment of the present invention includes a memory 200  
20 for storing a main program and data; a controller 100 for executing the main program stored in the memory 200 and controlling an overall operation of the health game apparatus; a sensor 300 for detecting a biological signal or vital sign; a display unit 700 for displaying game  
25 content and an operating state; and an input unit 900 for

receiving a biological data value and an operation command from a user.

In accordance with the one embodiment of the present invention, the controller 100 is implemented by a microprocessor. The sensor 300 can detect various biological signals or vital signs indicating a blood glucose level, a pulse rate, blood pressure, blood flow, bio-impedance, etc. In this embodiment, the sensor 300 measures a blood glucose level and can be replaced as a one-time sensor. The sensor 300 includes an electrode strip on which a pair of working electrodes and a reference electrode surrounded by a biological film is printed and a measuring circuit for measuring electric voltage across the electrode strip after electric current is applied to the electrode strip. In accordance with the one embodiment of the present invention, the display unit 700 is a liquid crystal display (LCD). The display unit 700 displays a charging/discharging state of a battery serving as a power supply, displays operating modes classified into a charging mode, a standby mode, a measurement mode, a game mode, etc., and displays a measurement data screen, a stored data query screen, a game progress screen, etc. The input unit 900 includes a joystick, a trackball or direction keys necessary for progressing a game. The input unit 900 includes a keypad necessary for receiving an operation

command and progressing the game.

The health game apparatus is a portable game apparatus not shown. The health game apparatus includes a battery and a power-supply stabilizing circuit. Where adopting a chargeable battery, the health game apparatus can further include a charging circuit.

In accordance with the present invention, the controller 100 includes a biological index producer for producing a quantized biological index associated with a biological function or state from a signal outputted by the sensor 300, and a game progress processor 150 for progressing a game according to a programmed game scenario in response to inputs of the produced biological index and the operation command.

In this embodiment, the biological index producer 110 digitally converts a signal value inputted from the sensor 300, i.e., a blood glucose measuring circuit, looks up a reference table, and produces a blood glucose level value. Since this operation is well known in relation to the conventional circuit and processing procedure provided in the existing blood glucose meter, a detailed description of the operation will be omitted.

The game progress processor 150 can process a competition game. The memory 200 stores a game program. The game program is executed so that the competition game based

on several steps can be performed along with one or more virtual opposite parties. In this case, the user's character has different features according to blood glucose level values produced by the biological index producer 110. For example, a history of blood glucose levels measured on a user-by-user basis is stored and managed in the memory 200. If a blood glucose level value of the user is good in comparison with an average glucose level value, energy of the user's character is increased and the character is expressed as a very bright color. On the other hand, if a blood glucose level value of the user is not good during a predetermined time in comparison with the average glucose level value, the user's character is expressed as a dark color. At this time, the user's character is in a disadvantageous position since the energy of the user's character is decreased. In another embodiment of the present invention, a weapon used in the competition game by the user's character, i.e., an item, is assigned according to a biological index produced by the biological index producer 110, i.e., a one-time measurement value indicating a blood glucose level or an average value accumulated during a predetermined time. In other words, when the good blood glucose level of the user is maintained during a predetermined time, a very powerful item is assigned to the user, and the user is in an advantageous position in the

competition game with virtual enemies.

When the game is progressed, the energy of the user's character can be interworked with a biological index in the form of an icon indicating the number. The energy of the user's character can be increased according to a game progress state or decreased where the user's character is damaged. For example, if the icon indicating an energy level is maintained as a good state of the blood glucose level, a kidney shape of a bright green color can be displayed. On the other hand, if the blood glucose level is in a bad state in comparison with a normal level, the kidney shape of a red color can be displayed.

In accordance with the present invention, the health game apparatus 10-1, 10-2 or 10-3 further includes a communication module 500 for communicating with a host computer through a network. The controller 100 further includes a health manager 130 for sending, to the host computer 30 through the communication module 500, biological state information after processing a biological index measured by the biological index producer 110 and a biological data value inputted through the input unit 900.

In accordance with this embodiment, the communication module 500 is a Bluetooth module, and is coupled to the Internet over a Bluetooth access point. The communication module 500 is not limited to the Bluetooth module. The

communication module 500 can be a mobile communication modem for supporting communication with the host computer 30 over a mobile communication network.

5 The health manager 130 sends a measured biological index, i.e., visual data indicating a blood glucose level, and user identification information to the host computer 30. The host computer 30 stores received data in a database on a user-by-user basis, and monitors the stored received data. For example, the host computer 30 sends a result of a  
10 processing operation performed by a professional system and sends an electronic mail to the professional computer connected by an online form, such that the professional computer sends a received opinion of the electronic mail to the user periodically or in case of emergency. In the mobile  
15 communication network, a response can be sent in the form of a short message. In the Bluetooth network, a response can be sent by means of an electronic mail or a messenger since two-way communication can be performed.

In accordance with another embodiment of the present  
20 invention, the game progress processor 150 further includes a progress data transmitting/receiving module 151 for performing game progress data communication with an opposite party coupled to the host computer 30 through the communication module 500. In other words, in accordance with  
25 the present invention, the competition game is not performed

between virtual characters provided from the program, but is performed between the user's character and an opposite party's character manipulated by another user of another health game apparatus connected over the network. Since this network-based game technology is well known, a detailed description of this network-based game technology will be omitted.

FIG. 3 is a schematic flow chart illustrating a processing operation performed by the health game apparatus and a host computer communicating with the health game apparatus in accordance with another embodiment of the present invention. As shown in FIG. 3, the health game apparatus produces a biological index and additionally performs a control operation for a graphic and a character in response to a control command from a server associated with game progress. The health game apparatus is used for a server-based game in which an operation for managing and controlling the game progress is performed by the host computer.

For example, the health game apparatus associated with obesity management will be described with reference to FIG. 3. As shown in FIG. 3, a method for processing health game data in accordance with the present invention produces a quantized biological index associated with a biological function or state from a signal inputted by the sensor

embedded in the health game apparatus at step 1110. For example, this procedure converts a received bio-impedance measurement signal into digital data and converts the digital data into a value indicating an amount of fat in a body by means of a bio-impedance measuring circuit. In the bio-impedance measurement operation, bio-impedance is measured in a state where a plurality of electrodes are in contact with a specified part of the body of the user by means of a conductor. In accordance with one embodiment of the present invention, measurement points can be both hands.

Next, the game apparatus sends the produced biological index to the host computer at step 1130. A signal indicating a blood glucose level value is periodically transmitted to the host computer by the health game apparatus or can be transmitted in response to a request from the host computer. Then, the host computer stores a received biological index on a user-by-user basis at step 1310. The host computer manages the stored biological index on the user-by-user basis. For example, the host computer monitors a variation state associated with a blood glucose level value sent from a game terminal on the user-by-user basis. If an abrupt variation is present, the host computer can send a text message as an alarm message.



In accordance with the present invention, the game apparatus receives biological data from the input unit 900 to perform a game on the basis of the received biological data at step 1150. For example, a biological data value is  
5 directly interfaced with the terminal in an obesity management game. The biological data value can be a weight or height value that cannot be frequently measured. An obesity degree can be correctly confirmed by comparing the inputted weigh and height values with the measured bio-  
10 impedance value. The inputted biological data value is sent to the host computer at step 1170. The host computer stores and manages the biological data value on the user-by-user basis as in the biological index at step 1330.

Then, if the user selects one game from a menu provided  
15 from the health game apparatus of the user, the health game apparatus accesses the host computer for game progress at step 1190. Then, the host computer progresses the game while taking into account an operation command from the health game apparatus, a stored biological index and additional  
20 biological data at step 1350.

In other words, the host computer stores biological indexes on the user-by-user basis and organizes a database. The host computer controls the game progress using the biological indexes stored in the organized database. The  
25 health game apparatus controls an output of a graphic for a

display unit or sound in response to a control command from the host computer.

For example, an obesity management game apparatus can be used for a cave adventure game. The user directly  
5 accesses the host computer or accesses the host computer over the network and progresses the game by fighting with monsters appearing in a cave in cooperation with other users joining the same game. At this time, a weapon or equipment for the game is provided as an item according to a game progress or  
10 biological index.

In accordance with the present invention, a form displaying the user's character joining the game can be different according to the produced biological index on the user-by-user basis. For example, the user's character is  
15 displayed in a fat form proportionate to the high obesity degree where the obesity degree of the user is high. A display control operation as a graphic processing operation can be easily implemented by those skilled in the art.

Additionally, in accordance with the present invention,  
20 a form of displaying the user's character for the game can be different according to biological data values stored in the host computer. In the case of the obesity management game, the character correctly indicates a current body state of the user, and the user can be stimulated through the character  
25 indicating the current body state and can feel the need for

obesity management.

In accordance with the present invention, an item capable of being used in a game or a level of the game character is assigned or differently assigned according to  
5 the produced biological index or stored inputted biological data.

FIG. 4 is a schematic block diagram illustrating a health game apparatus in accordance with another embodiment of the present invention. An example of the health game  
10 apparatus includes a circuit for detecting a biological signal or vital sign in addition to the above-described battery pack of the mobile phone.

As shown in FIG. 4, a battery pack 11 in accordance with the embodiment of the present invention includes a  
15 signal processor 310 for performing pre-processing operations such as a filtering operation and an amplifying operation for an analog signal from the sensor and performing a digital conversion operation; the first interface 190 for performing data communication with the  
20 mobile-phone main body; and a pack controller 180 for controlling an overall operation of the health game apparatus.

In accordance with this embodiment, a sensor 300 includes four electrodes necessary for measuring bio-  
25 impedance. The signal processor 310 includes a constant-

current drive circuit for supplying constant current to the four electrodes; a voltage measuring circuit for measuring voltage across the electrodes; an amplifying circuit; a filtering circuit; and an analog-digital conversion circuit for converting a filtered signal value into a digital value. The pack controller 180 communicates with the main body controller 100. Upon receiving a measurement initiation command, the pack controller 180 controls the signal processor 310 to measure bio-impedance and sends a measurement value of the bio-impedance to the mobile-phone main body through the first interface 190. In accordance with the embodiment, the first interface 190 is a USB interface. Alternatively, the first interface 190 can be directly connected to a USB interface of a signal jack for the mobile phone through a cable, and can be designed so that several terminals are added to an electrode coupled to the battery pack and the mobile-phone main body in a sliding manner and the several terminals can be in contact with the first interface 190.

The mobile-phone main body 13 includes a display unit 700, an input unit 900, a communication module 500, a memory 200, a main body controller 100 and the second interface 170. Since the display unit 700, the input unit 900, the communication module 500 and the memory 200 shown in FIG. 4 are identical to those shown in FIG. 2, and a

configuration of the second interface 170 corresponds to that of the first interface 190, a description of those elements will be omitted. In addition to an operation of the controller 100 shown in FIG. 2, the main body  
5 controller 100 communicates with a battery pack 11. The main body controller 100 acquires biological signal data or vital sign data through the second interface 170 and outputs, to the second interface 170, command data for commanding measurement initiation according to a  
10 predetermined protocol.

In accordance with this embodiment, a game progress processor 150 is directly interfaced with a health manager 130. The game progress processor 150 can be implemented by various programs and can be downloaded from a computer  
15 coupled to a wireless Internet or a cable. An interface of a game module is standardized according to the type of data to be processed by the health manager 130. When the user selects the execution of a downloaded game program, for example, a corresponding game is executed on the basis of a  
20 virtual machine of the mobile phone. A biological index producer 110 and the health manager 130 are provided as independent application programs, and are selectively mounted according to a type of the battery pack 11. In accordance with the preferred embodiment, the application  
25 programs configuring the biological index producer 110 and

the health manager 130 are downloaded from the battery pack 11 through the second interface, stored in a specified area of the main body 13 so that the application programs stored in the specified area of the main body 13 can be executed.

5           A method for processing health game data in accordance with another embodiment of the present invention includes the steps of: producing a quantized biological index associated with a biological function or state from a signal inputted by a sensor provided in a health game  
10 apparatus; allowing the game apparatus to send the produced biological index to a host computer and to store the produced biological index on a user-by-user basis; allowing the health game apparatus to access the host computer in response to a game selected by a user; allowing the host  
15 computer to receive and disclose request information for joining a group from the user and to process participation requests from game members to configure groups; allowing the host computer to select an opposite group from the configured groups; and allowing the host computer to  
20 progress the game according to the biological index stored on the user-by-user basis and an operation command from the health game apparatus.

          Preferably, the method for processing the health game data can further include the step of: making an agreement  
25 for a game progress rule between groups joining the game.

Preferably, the method for processing the health game data can further include the step of: giving notification indicating a game progress state to members belonging to the groups.

5           FIG. 5 is a schematic flow chart illustrating a method for processing health game data performed by a server serving as a host computer and a game client mounted in a terminal in accordance with another embodiment of the present invention. In accordance with this embodiment, a  
10           plurality of users configure groups, and a game is progressed in the form of a competition between groups. The method for processing the health game data will be described in detail with reference to FIG. 5.

          First, users individually perform a login operation  
15           to access the host computer at step 2010. When one of the users selects a group generation menu item, the host computer configures a new group, designates a leader of the group and stores information associated with the new group and its leader in a database at step 2020. Then, notice of  
20           the new group is given, for example, by posting to a bulletin board, and the group leader advertises his or her own group through detailed content of the bulletin board. In the login state, new users read group advertisement content of the bulletin board and select groups to  
25           participate in. In terms of special requirements on a

group-by-group basis, a current weight and height and a range of body fat measured from bio-impedance can be limited in the case of a weight reduction game.

If group members arrive at the predetermined number,  
5 a group formation is completed. Any group member cannot arbitrarily withdraw from the group if the group is formed as a characteristic of the game. The group leader listens to opinions from the group members and proposes the game to other groups. At this time, a plurality of games can be  
10 provided between the groups, and one of the games is selected. When the group selects one of other groups and the one of other groups accepts the selection, the selected group is set as an opposite group at step 2030.

At this time, an agreement for a detailed game  
15 progress rule is made at step 2040. For example, if notification indicating a sum of weights of all group members is made and a target weight sum is set, a time limit necessary for arriving at the target weight sum is designated. A victory or defeat in the game is basically  
20 determined according to whether or not the target weight sum is achieved within the time limit. A degree of game participation of the group members can be expressed as a numerical value. For example, an area of a city is assigned to each member in a city construction game and the city can  
25 be uniquely constructed on an area-by-area basis.



Furthermore, a target can be to optimally construct a road network and a communication network through mutual communication. At this time, the city constructed by a road simulation operation and a communication simulation operation can be evaluated in real time. Furthermore, a game score is calculated according to a ratio of buildings and spaces, the number of members joining the city construction game, a result of a defense operation against an assault for destroying an opposite city, etc. Since the above-described game is well known, a detailed description of the game will be omitted.

On the other hand, if users perform a login operation to access the host computer and select an item of a corresponding group game menu, a current game progress state is displayed. At this time, a user's weight and an amount of body fat are displayed on one side of a top area of the display unit, and a current weight sum, a target weight sum and an average body-fat amount associated with a group to which the user belongs are displayed on the other side of the top area of the display unit. Current weight values and fat amounts of the members are disclosed according to the user's selection, and a short message as an encouragement message can be sent to the group's members who are far away from their target values. An operation for exchanging the message is performed through a server, and

the exchanged message can be reflected in the game score.

In the case of the city construction game, an area of the city assigned to a user is indicated on a screen and game progress states of other users are monitored on the screen.

5 The user selects construction materials and performs a construction operation at step 2050. A game client performs a graphic processing operation and sends a data value indicating a result of the processing operation to the host computer. The host computer can receive the data value,  
10 organize a database storing information of an entire construction state and perform a synchronization operation associated with the game progress state. The synchronized game progress state can be periodically known to other members and confirmed at step 2060.

15 The host computer determines whether a predetermined score is obtained or a completion requirement is satisfied at step 2070. If the completion requirement is satisfied, the host computer searches for a winner group in the game competition and a best member of the winner group so that  
20 incentive such as congratulation messages, gifts, etc. is provided to the winner group and the best member of the winner group at step 2080. Then, the game is terminated at step 2090.

25 Industrial Applicability

As apparent from the above description, the present invention provides a health game apparatus and method using the same, which can provide a communication function to portable medical equipment for measuring a biological signal or vital sign associated with disease and beauty, execute a downloaded game program on the basis of measured biological data, such that continuous interest and stimulation in managing a user's health can be promoted.

Further, the present invention simplifies a data input operation in comparison with the conventional game apparatus, such that a user allows data to be easily and conveniently inputted.

Furthermore, the present invention allows persons having a similar disease or beauty problem to enjoy an online game, to exchange information over the same virtual space and to form a community through the promotion of close relations.

Still furthermore, the present invention allows the user's health state to be expressed as a character or icon and allows the user's health state to be shown to other users, such that health care can be further promoted.

Although the preferred embodiments of the present invention have been disclosed for illustrative purposes, those skilled in the art will appreciate that various modifications, additions and substitutions are possible,

without departing from the scope of the invention. Accordingly, the present invention is not limited to the above-described embodiments, but the present invention is defined by the claims which follow, along with their full  
5 scope of equivalents.

Claims:

1. A health game apparatus, comprising:

a sensor for detecting a biological signal;

5 an input unit for receiving an operation command from a user;

a controller comprising a biological index producer for producing, as a numerical value, a quantized biological index associated with a biological function or state on the basis of the biological signal detected by the sensor; and  
10 a game progress processor for progressing a game according to a programmed game scenario in response to the produced biological index and the operation command; and

a display unit for displaying game content and an  
15 operating state.

2. The health game apparatus as set forth in claim 1, further comprising:

a communication module for communicating with a host  
20 computer over a network,

wherein the controller further comprises:

a health manager for sending, to the host computer through the communication module, biological state information indicating a result of a processing operation  
25 for the biological index measured by the biological index

producer and a biological data value inputted through the input unit.

3. The health game apparatus as set forth in claim 2,  
5 wherein the game progress processor comprises:

a progress data transmitting/receiving module for performing game progress data communication with an opposite party coupled to the host computer through the communication module.

10

4. The health game apparatus as set forth in any one of claims 1, 2 and 3, wherein the game progress processor additionally progresses the game according to a biological data value inputted through the input unit.

15

5. A method for processing health game data, comprising the steps of:

(a) producing a quantized biological index associated with a biological function or state from a signal inputted  
20 by a sensor provided in a health game apparatus;

(b) allowing the game apparatus to send the produced biological index to a host computer and to store the produced biological index on a user-by-user basis;

(c) allowing the health game apparatus to access the  
25 host computer in response to a game selected by a user; and

(d) allowing the host computer to progress the game according to the biological index stored on the user-by-user basis and an operation command from the health game apparatus.

5

6. The method as set forth in claim 5, further comprising the steps of:

(e) allowing the game apparatus to receive a biological data value from an input unit provided in the health game apparatus and to transmit the received biological data value to the host computer; and

10

(f) allowing the host computer to store the biological data value on the user-by-user basis,

wherein the step (d) is carried out by progressing the game according to the stored biological data value in addition to the biological index and the operation command.

15

7. The method as set forth in claim 5, wherein the step (d) comprises the step of:

differently displaying a game character of a corresponding user on the user-by-user basis according to the produced biological index.

20

8. The method as set forth in claim 6, wherein the step (d) comprises the step of:

25

differently displaying a game character of a corresponding user on the user-by-user basis according to the produced biological index or the received biological data value.

5

9. The method as set forth in claim 5 or 7, wherein the step (d) comprises the step of:

assigning an item capable of being used in the game or differently assigning a level of a game character according to the produced biological index.

10

10. The method as set forth in claim 6 or 8, wherein the step (d) comprises the step of:

assigning an item capable of being used in the game or differently assigning a level of a game character according to the produced biological index or the received biological data value.

15

11. A health game apparatus, comprising:

a battery pack comprising a sensor for detecting a biological signal, a signal processor for pre-processing an analog signal from the sensor and converting the analog signal into a digital signal; a first interface for performing data communication with a mobile-phone main body; and a pack controller for controlling an overall

25



operation of the health game apparatus;

a second interface coupled to the first interface;

an input unit for receiving an operation command from  
a user;

5 a display unit for displaying game content and an  
operating state;

a main body controller for outputting command data  
for commanding measurement initiation to the second  
interface on the basis of a predetermined protocol, the  
10 main body controller comprising a biological index producer  
for producing, as a numerical value, a quantized biological  
index associated with a biological function or state from  
data inputted through the second interface; and a game  
progress processor for progressing a game according to a  
15 programmed game scenario in response to the produced  
biological index and the operation command; and

the mobile-phone main body capable of being coupled  
to or removed from the battery pack.

20 12. The health game apparatus as set forth in claim  
11, further comprising:

a communication module communicating with a host  
computer over a network,

wherein the controller further comprises:

25 a health manager for sending, to the host computer

through the communication module, biological state information indicating a result of a processing operation for the biological index measured by the biological index producer and a biological data value inputted through the input unit, and

5

wherein the game progress processor comprises:

a progress data transmitting/receiving module for performing game progress data communication with an opposite party coupled to the host computer through the communication module.

10

13. The health game apparatus as set forth in claim 12, wherein the biological index producer and the health manager are configured by one application program, respectively.

15

14. The health game apparatus as set forth in claim 13, wherein the game progress processor is downloaded from the host computer as one application program and is installed on the basis of the one application program.

20

15. A method for processing health game data, comprising the steps of:

(a) producing a quantized biological index associated with a biological function or state from a signal inputted

25

by a sensor provided in a health game apparatus;

(b) allowing the game apparatus to send the produced biological index to a host computer and to store the produced biological index on a user-by-user basis;

5 (c) allowing the health game apparatus to access the host computer in response to a game selected by a user;

(d) allowing the host computer to receive and disclose request information for joining a group from the user and to process participation requests from game  
10 members to configure groups;

(e) allowing the host computer to select an opposite group from the configured groups; and

(f) allowing the host computer to progress the game according to the biological index stored on the user-by-  
15 user basis and an operation command from the health game apparatus.

16. The method as set forth in claim 15, further comprising the step of:

20 (g) making an agreement for a game progress rule between groups joining the game.

17. The method as set forth in claim 15 or 16, further comprising the step of:

25 (h) giving notification indicating a game progress

state to members belonging to the groups.

FIG. 1

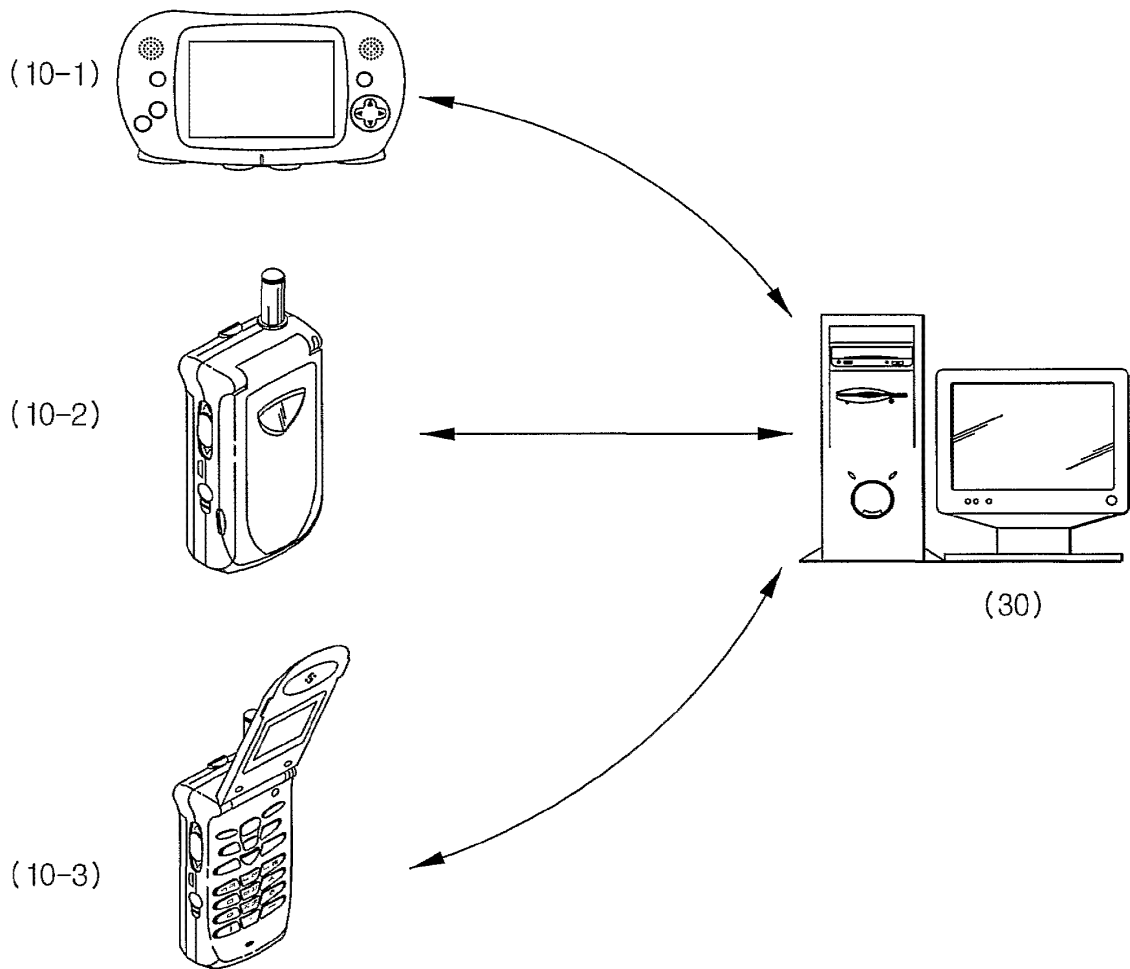

FIG. 2

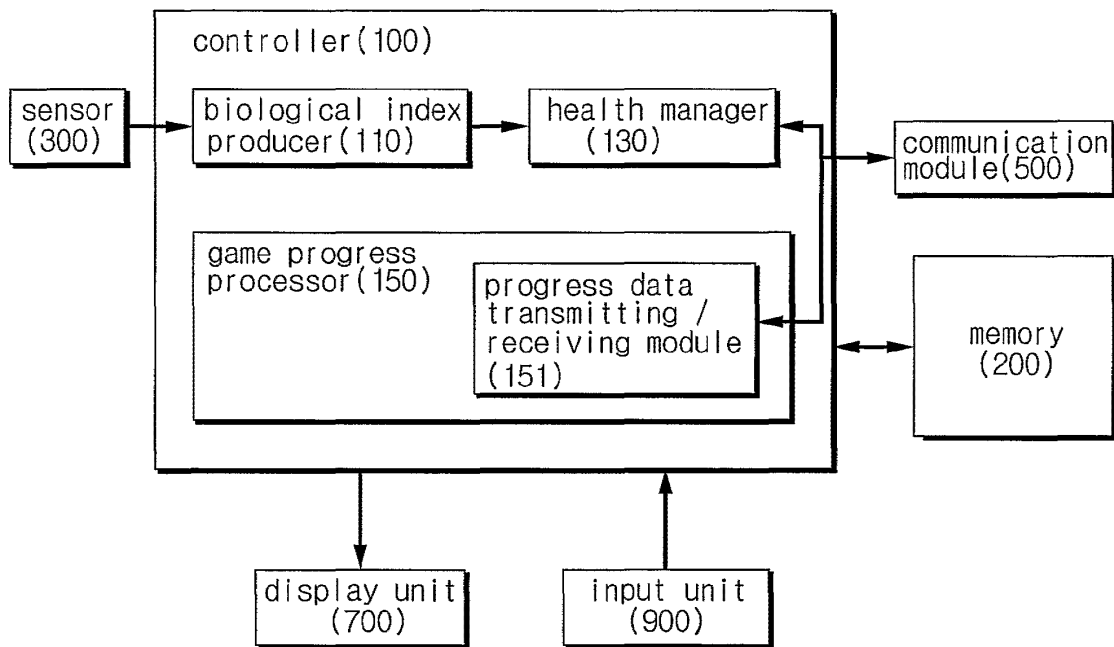

FIG. 3

3/5

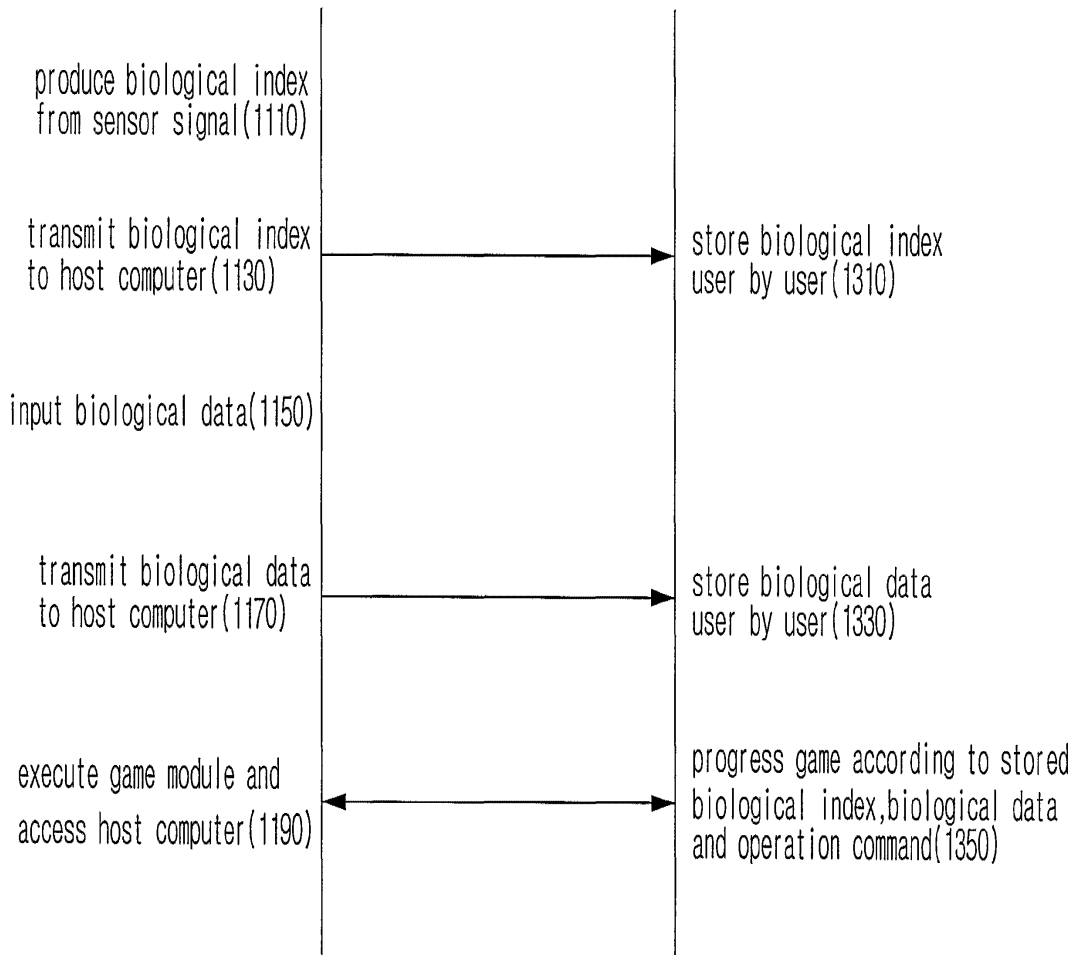

FIG.4

