

## CLOSED CAPTIONING WITH THE LINE 21 SYSTEM

Sharon Earley

NATIONAL CAPTIONING INSTITUTE, INC.

### ABSTRACT

Closed captioning has enabled the hearing impaired to enjoy television more fully over the past three years. Although over-the-air broadcasters have provided the bulk of closed-captioned programs, the participation of the cable industry is both growing and promising. The Line 21 system, with its proven transmission and reception strengths, is an ideally suited caption delivery system for cablecasters. The Line 21 signal passes intact over satellite and cable. It can be recorded in three-quarter and half-inch formats, and no special accommodations are required to retransmit it. Decoding devices, specifically designed for cable, are currently available, as is a system which enables a local operator to caption its own programming in a cost-effective manner. The National Captioning Institute sees the full participation of cablecasters in the provision of closed captions as an important step in increasing the access of the hearing impaired to television programming.

### CLOSED-CAPTION SERVICE

For the past three decades, television has been a primary medium of communication for most Americans. It has become our major source of information about the world and our principal source of entertainment. But for many years, television's voice remained distorted, muted or totally silent for some 16 million Americans with impaired hearing. The situation changed in March, 1980, when the Public Broadcasting Service and the ABC and NBC television networks began broadcasting 16 hours of predominantly prime-time programming with closed captions produced by the National Captioning Institute, Inc. (NCI).

Closed captioning involves representing the sound track of television programs in subtitles which are telecast as data in the vertical blanking interval and are visible only to those viewers whose sets are equipped with special decoding devices. While in theory closed captions can be provided by any teletext system, only one, currently known as the Line 21 system, is actually in use and delivering captions

nationally. At present, 300,000 viewers across the country who use Line 21 TeleCaption<sup>®</sup> decoding devices enjoy over 40 hours per week of predominantly prime-time network programming. More than 200 major advertisers caption their commercials and support the costs of captioning television specials and series.

Although the closed-caption service began three years ago primarily as a broadcast network service, it has expanded into many other delivery systems -- satellite syndication, videocassette, videodisk, local broadcast and cable.

### DEVELOPMENTS IN CABLE

The cable industry's first involvement in closed captioning was the delivery of closed-captioned network programs to subscribers. Since 1982, however, cable support and involvement in the closed-caption service has been active and growing rapidly.

In early 1982 Showtime became the first subscription service to offer its own closed-captioned programming -- the BIZARRE series. Shortly thereafter Showtime added selected movies to its closed-captioned fare. In mid 1982 Colormax Electronic Corporation began production of two closed-caption decoding devices designed specifically for the cable audience -- a combination converter/Line 21 decoder, and a Line 21 decoder module that attaches to a cable converter. Such units and the standard Sears (Sanyo) TeleCaption decoder are being acquired by operators such as Tampa Cable Television and American Cable Systems, whose specific commitments to provide closed-caption decoders were made in their franchise bids.

Cable subscribers can now obtain news and features of special interest to the hearing impaired via the KEYFAX National Teletext Magazine, a service provided cooperatively by NCI and KEYCOM Electronics Publishing. Most recently, Tribune Cable Communications, Inc., has agreed to provide funds to closed caption one movie every month for hearing-impaired subscribers. The first movie captioned under

this arrangement is POLTERGEIST, to appear on Showtime in June, 1983. Other MSO's are currently considering similar underwriting arrangements to provide closed-caption services for the benefit of their hearing-impaired subscribers.

While such activities generate enormous good will and demonstrate the cable industry's commitment to serve all facets of its market, they also make good business sense. NCI research indicates that while currently only 38% of all decoder households subscribe to cable television, 82% would subscribe to basic cable services if closed-captioned cable services were available. Under those circumstances, 68% would subscribe to pay cable compared to the 28% who currently do so. Further, of those who do not own a closed-caption decoder, approximately 78% would rent one from a cable company.

#### CLOSED-CAPTION SYSTEM DEVELOPMENT

The Line 21 system was designed specifically to provide closed captions to the hearing impaired. For this reason, fundamental to its specifications was that it require little investment in effort and hardware by the telecaster, that it be sufficiently rugged to pass unmodified through all television media, and that it be inexpensive for the consumer to access.

Development of the Line 21 closed-captioning system was conducted by the PBS Engineering Department with funds provided by the U.S. Department of Health, Education and Welfare (HEW). This work commenced in 1973 and was largely completed in 1979. The PBS task had three major components, each of which had to be completed successfully before a closed-captioning service could be implemented.

The first task was to evaluate the technique of closed captioning as a meaningful service for the hearing impaired. To measure this, PBS established an experimental closed-captioning capability and conducted controlled testing with the hearing-impaired community during 1974. PBS obtained the cooperation of 12 member stations across the country who demonstrated closed-captioned television programs to the hearing-impaired viewers and had them complete over 1,400 opinion forms. Gallaudet College, the world's foremost educational institution for the hearing impaired, analyzed the completed questionnaires. The major findings were that 90% of the audience said they could not have understood the TV programs shown to them had they not been captioned and 95% said they would purchase special equipment to receive closed captions.

During this same period and on into 1975, PBS was studying the various technical hurdles it faced in developing an approach to closed-captioned television. By November, 1975, sufficient work had been completed for PBS to file a petition with the Federal Communications Commission (FCC) requesting the allocation of Line 21 for the introduction of a closed-captioned service. In December, 1976, the FCC approved such an allocation. With the FCC approval obtained, PBS began fabrication of the caption editing console which enables caption preparation to be completed efficiently, secured agreements from manufacturers to produce the encoder which lays the Line 21 data stream into the vertical interval and the first consumer decoders -- a integrated 19" color television set and the add-on decoder -- which Sears Roebuck agreed to retail. Finally, the question of who would perform the actual captioning service was answered when the non-profit and private National Captioning Institute was incorporated in early 1979.

#### CAPTION CREATION AND ENCODING

NCI creates captions in three different ways, depending upon the nature of the program to be captioned. A recent advance in caption creation technology known as real-time captioning enables virtually every program type to be closed captioned. The three methods employed by NCI to caption, and a method available to local program suppliers, are described below.

Prerecorded Programming. NCI receives a time-coded videocassette dub of the program master and, if available, a script of the program. A caption editor works with the program in short sections, and composes each caption. The editor determines the caption content, its location on the screen, and the times at which it will appear and disappear. All of this data is entered onto an 8" floppy disk via the caption editing console, which has word processing capability to facilitate the process. Once all captions for a program have been prepared and entered, they are played back over video and checked for accuracy and quality.

The captions on disk are transferred to Line 21, Field 1 of the standard NTSC video signal in the encoding process. To encode captions a Simple Encoder, comprised basically of a microprocessor, a time code reader and a floppy disk reader, is utilized. Required inputs are SMPTE time code and program video from the master videotape. The microprocessor synchronizes the serial caption data with the time code and requests additional captions

from the disk reader when the encoder memory buffer is near depletion. The caption data is inserted into Line 21 of the video.

#### TAPE ENCODING

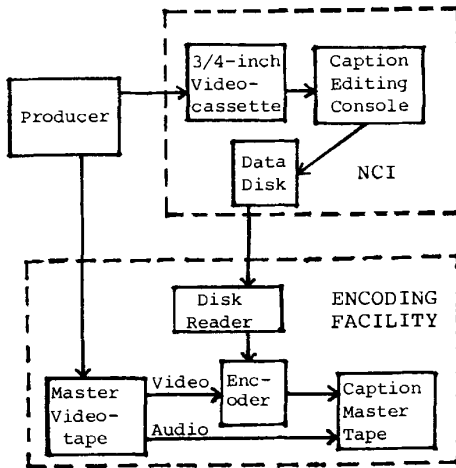

Prescribed Live Programs. Presidential addresses and other programs which are broadcast live are often accurately prescribed. With the cooperation of the White House or producer, NCI obtains the script in advance of broadcast. Without the benefit of video or audio, the editor must break the text into captions. These captions are entered onto the disk without preset display and erase times. As the live event occurs, the caption editor manually recalls the captions from the disk for display in sync with the audio.

Due to the nature of these programs, encoding must be done "live." The hardware which enables live encoding is a Smart Encoder. This device is resident at the program origination point and is capable of inserting caption data on Line 21 of the video being fed through it. NCI transmits the captions to the Smart Encoder at 1200 baud rate, asynchronously, over standard unconditioned telephone lines.

#### LIVE ENCODING

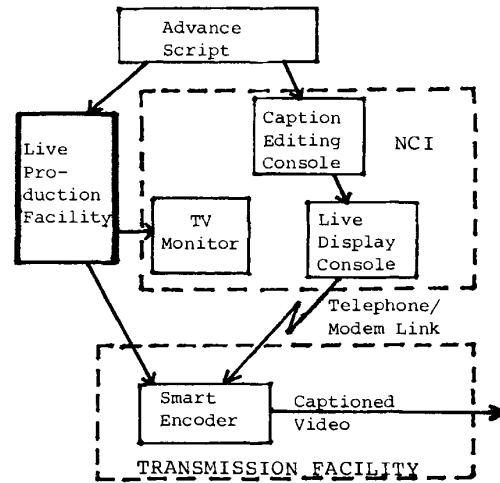

Live News and Events. For news and other programs, scripts are not available to NCI in advance of broadcast. Until last year, such programs were uncaptionable. In October, 1982, however, NCI began to employ its real-time captioning system on a daily basis to caption ABC-TV's WORLD NEWS TONIGHT. The system has been employed to caption space shuttle launches and the Academy Awards.

The trick to real-time captioning is that captions must not only be transmitted live, they must be created instantaneously. To accomplish this, NCI has borrowed and modified a technology employed by court reporters to speed the translation of machine shorthand to standard English. Stenographic translation is the computerized translation into real words and names of a stenotypist's machine shorthand "strokes" which are a phonetic representation of what the stenotypist hears.

NCI uses a stenographic translation system developed by Translation Systems, Inc., modified by TSI and NCI and known as InstaText. The heart of InstaText is its dictionary system, which translates the stenotypist's strokes into real English. The main dictionary is called the "universal" dictionary. This contains the many thousands of words in common usage. The universal dictionary is the permanent facet of the dictionary system, though updated and revised from time to time. Next is the "personal" dictionary peculiar to the individual stenotypist which contains special abbreviations, used only by him or her. The third dictionary to which the computer will turn to "look up" a word is

the "dope sheet," which contains entries appropriate to a specific task, such as the names and places likely to be mentioned in a given newscast.

In making translations, the computer checks each of these dictionaries and matches the stenographic outline entered on the stenotype machine with the corresponding English word or words. A skilled stenotypist will achieve accurate translation on better than 97% of all entries.

As translation takes place, the text is formatted into captions according to parameters which can be set either by the stenotypist or by an NCI editor operating the main computer keyboard. These parameters can be set in real time so that each line or word can be treated differently, include line length, indentation, upper or upper/lower case, and line justification for left, right, or center display and display rate.

The text must be then transmitted to a display system. In the case of NCI, that system is a Line 21 decoder via the Line 21 Smart Encoder as described above.

Local Programming. Although NCI has and will continue to caption programs for local markets, a very cost-effective system is available to local stations and cablecasters with which to caption programming they produce. This system utilizes a Beston Electronic Data-Prompter and an EEG Smart Encoder. The Data-Prompter is an electronic word processor which has a character-generated output that can be fed directly to a standard prompter monitor. As the text is being presented to the talent, it can also be sent to the Line 21 Smart Encoder, enabling closed captions to be transmitted simultaneously with the program.

KCMO-TV, the CBS affiliate in Kansas City, is currently utilizing this system to provide closed captions for its local newscasts, and many cable systems are showing interest in the system for use with their local access programs.

#### DATA-PROMPTER CAPTIONING

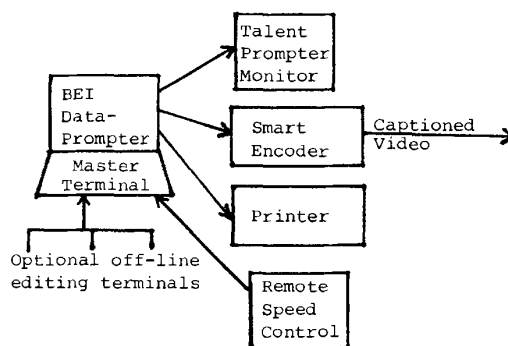

#### LINE 21 TRANSMISSION AND RECORDING

Once Line 21 closed captions are inserted into video they require no special accommodation by the broadcaster or cablecaster. All that is required is that video facilities be checked to insure that they are passing Line 21, Field 1 intact. The ease of retransmission is due to the relatively low data rate of the Line 21 signal which makes it very rugged.

The Line 21 waveform conforms to the standard Television Synchronizing Waveform for Color Transmission given in Subpart E, Part 73 of the FCC Rules and Regulations. The composite data signal contained within the active video portion of the line period carries a clock run-in (data synchronizing signal), and a start bit, followed by 16 data bits. The instantaneous data rate is thirty-two times horizontal line scanning frequency ( $32F_H$ ) for a nominal value of 0.5 mb/s. After allowance for the duty cycle of the Line 21 signal, and start bits, an average data transmission rate of 480 bits per second is obtained which translates into 60 characters (7 bit ASCII + 1 parity bit) per second.

Just as Line 21 closed captions pass without difficulty over existing transmission modes -- over-the-air, cable and satellite -- they are recordable in all existing video formats, including 3/4-inch, 1/2-inch (Beta and VHS), and video disk. When programming is transmitted on a 3/4-inch format, however, it is important to note that many 3/4-inch cassette machines do not have framing (field differentiating) servo systems and will randomly lock in the opposite field from a house reference sync. This will usually be the advanced vertical from a time base corrector when it is connected to the playback machine. As a result, Line 21, Field 1 information may flip to Field 2 on either

Line 20 or Line 21. The home decoder must see caption data on Line 21, Field 1 in order to decode and display captions. (The Sony BVU series, or its equivalent, that employs a framing servo does have this problem and can be used with a time base corrector without exhibiting field reversal providing the program was recorded on a machine with a framing servo.)

If a non-framing servo machine is used for playback with no time base correction and the signal that was recorded is at proper IRE levels, then Line 21, Field 1 information recorded on the tape will remain unaltered during playback, allowing captions to be decoded and displayed on the home receiver.

#### LINE 21 AND TELETEXT

The FCC decision last month to preserve Line 21 for closed captioning came as welcome support to hearing-impaired consumers who have made an investment of over 30 million dollars in home decoding equipment to date. The open-market approach to teletext standards, including the ruling by the Commissioners that cable television systems are not bound by the must-carry rule insofar as broadcast teletext services are concerned, and the adoption of incompatible teletext systems by broadcasters and cablecasters alike, will mean that for the foreseeable future the Line 21 system will remain the only national delivery system for program-related captions.

With the advent of teletext in the United States, NCI recognizes the practicality of making the Line 21 system compatible with the various teletext

systems so that hearing-impaired viewers who invest in teletext decoders do not also need Line 21 decoders. Toward that end NCI has been cooperating with World Standard and NABTS teletext equipment manufacturers to develop a black box which can transcode Line 21 captions to either teletext format. Such transcoders will enable captions to pass as usual on Line 21 and to be duplicated and transmitted simultaneously in the appropriate teletext format.

In November of 1982 such transcoding between Line 21 and World Standard teletext was successfully demonstrated in Washington, D.C. In March, 1983, a transcoder was installed at WNET-TV in New York with transcoded captions transmitted by Manhattan Cable. An NABTS transcoder is currently under development in Canada and is expected to be available this fall.

#### CONCLUSION

The Line 21 system for closed captioning has become widely accepted and utilized in the four years since it made its debut, and its growth continues at an exciting pace. Major support for the system is arising from the cable industry. The creation, transmission and reception of closed captions is reliable, straightforward and proven. For cable operators who wish to provide this valuable service to the hearing impaired, the Line 21-based system is a cost-effective and trouble-free way to do so. NCI has every expectation that the growth of cable television across the nation will lead to increasing access to television for the hearing impaired.