

- [54] **DIGITAL VIDEO COMPRESSION SYSTEM AND METHODS UTILIZING SCENE ADAPTIVE CODING WITH RATE BUFFER FEEDBACK**
- [75] Inventors: **Robert D. Widergren, Saratoga; Wen-Hsiung Chen, Sunnyvale; Stanley C. Fralick, Saratoga; Andrew G. Tescher, Claremont, all of Calif.**
- [73] Assignee: **Compression Labs, Inc., San Jose, Calif.**
- [21] Appl. No.: **969,991**
- [22] Filed: **Dec. 15, 1978**
- [51] Int. Cl.<sup>3</sup> ..... **H04N 7/12; H04N 9/32; G06F 15/20; G08C 9/00**
- [52] U.S. Cl. .... **358/136; 358/13; 340/347 DD; 364/514; 364/515; 364/582**
- [58] Field of Search ..... **364/514, 515, 576, 582; 358/12, 13, 133, 138, 260, 261; 340/347 DD**

- [56] **References Cited**
- U.S. PATENT DOCUMENTS**
- |           |         |                         |           |
|-----------|---------|-------------------------|-----------|
| 3,795,763 | 3/1974  | Golding et al. ....     | 358/135 X |
| 3,984,626 | 10/1976 | Mounts et al. ....      | 358/135   |
| 4,005,411 | 1/1977  | Morris ..... 340/347 DD |           |
| 4,047,221 | 9/1977  | Yasuda et al. ....      | 358/136   |
| 4,051,530 | 9/1977  | Kuroda et al. ....      | 358/136   |
| 4,054,909 | 10/1977 | Kojima et al. ....      | 358/13    |
| 4,060,797 | 11/1977 | Maxwell et al. ....     | 325/419 X |
| 4,125,861 | 11/1978 | Mounts et al. ....      | 358/133   |
| 4,168,513 | 9/1979  | Hains et al. ....       | 358/261   |
| 4,179,710 | 12/1979 | Ishiguro et al. ....    | 358/13 X  |

**OTHER PUBLICATIONS**

Image Data Compression by Predictive Coding II: Encoding Algorithms Bahl & Kobayashi: IBM J. Res. Develop., Mar. 1974, pp. 172-179.

Frame-to-Frame Coding of Television Pictures Using Two-Dimensional Fourier Transforms: Haskell: IEEE Transactions on Info. Theory: vol. IT-20, No. 1, pp. 119-120. Jan. 74.

Spahal Transform Coding of Color Images: Pratt: IEEE Transactions on Comm. Technology, vol. Com-19, No. 6, Dec. 71, pp. 980-992.

Goertzel et al., *Two-Dimensional Data Compression & Decompression System*; Aug. 7, 1979.

Application of Fourier-Hadamard Transformation to

Bandwidth Compression-Pratt & Andrews Proc. Polytechnic Institute of Brooklyn, 1969, pp. 56-68.

Hadamard Transform Image Coding, Pratt, Kane, Andrews, Proc. IEEE, vol. 57, No. 1, Jan. 69, pp. 58-68.

Television Bandwidth Reduction by Encoding Spatial Frequencies, Andrews & Pratt, Journal SMPTE, vol. 77, No. 12, Dec. 1968, pp. 1279-1281.

Television Bandwidth Reduction by Fourier Image Coding; Andrews & Pratt, Paper Delivered to 103rd Technical Conference SMPTE, May 5-10, 1968.

Transform Image Coding, Andrews & Pratt: Proc. Symposium on Computer Processing in Communications, Polytechnic Institute of Brooklyn, Apr. 8-10, 1969, pp. 63-84.

*Primary Examiner*—James W. Moffitt  
*Assistant Examiner*—Aristotelis M. Psitos  
*Attorney, Agent, or Firm*—David B. Harrison

[57] **ABSTRACT**

A digital video compression system and its methods for compressing digitalized video signals in real time at rates up to NTSC color broadcast rates are disclosed. The system compressor receives digitalized video frames divided into subframes, performs in a single pass a spatial domain to transform domain transformation in two dimensions of the picture elements of each subframe, normalizes the resultant coefficients by a normalization factor having a predetermined compression ratio component and an adaptive rate buffer capacity control component and an adaptive rate buffer capacity control feedback component, to provide compression, encodes the coefficients and stores them in a first rate buffer memory asynchronously at a high data transfer rate from which they are put out at a slower, synchronous rate. The compressor adaptively determines the rate buffer capacity control feedback component in relation to instantaneous data content of the rate buffer memory in relation to its capacity, and it controls the absolute quantity of data resulting from the normalization step so that the buffer memory is never completely emptied and never completely filled. In expansion, the system essentially mirrors the steps performed during compression. An efficient, high speed decoder forms an important aspect of the present invention. The compression system forms an important element of a disclosed color broadcast compression system.

7 Claims, 30 Drawing Figures

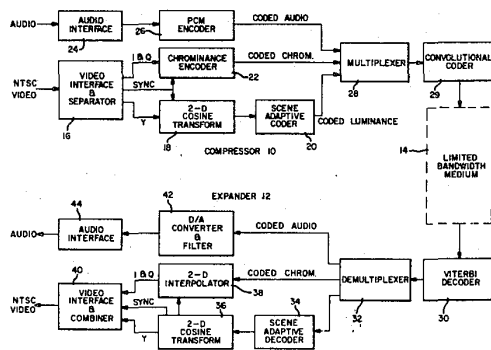

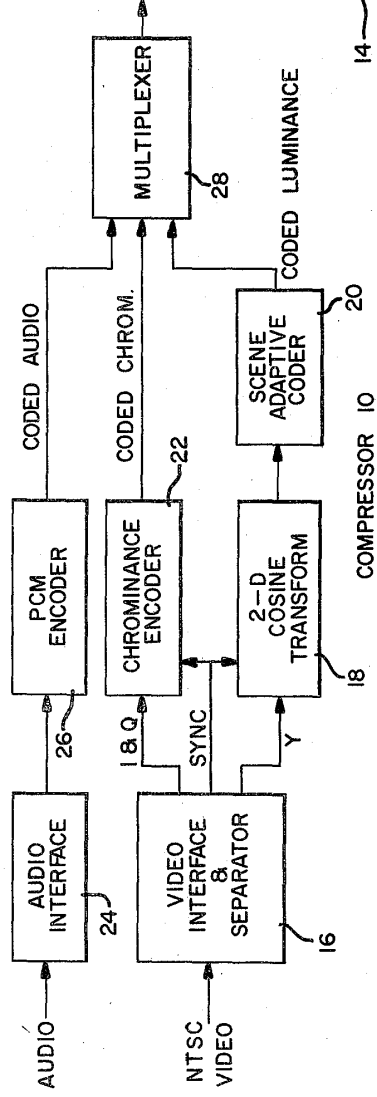
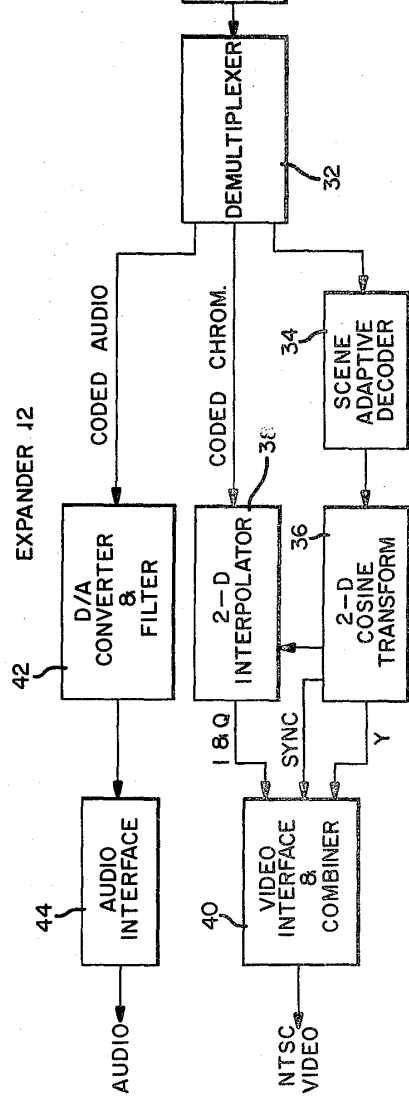

FIG. 1



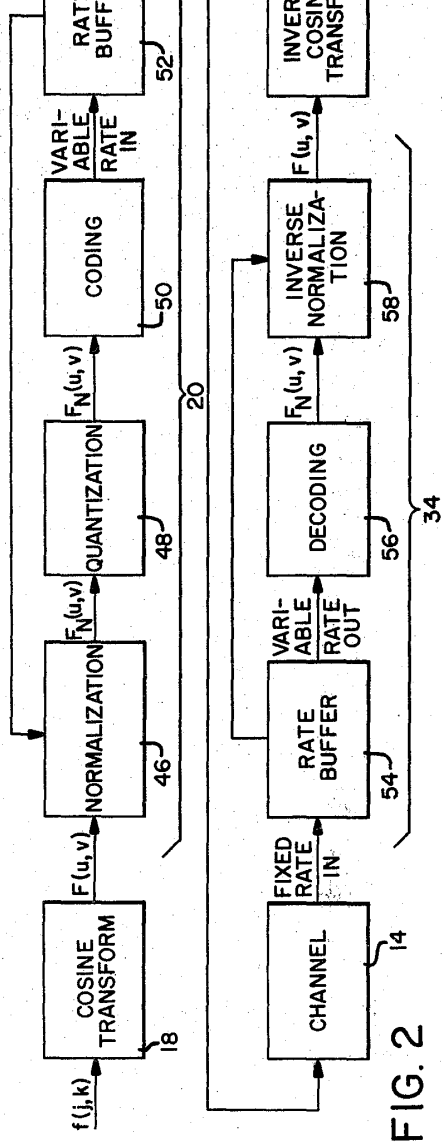

FIG. 2

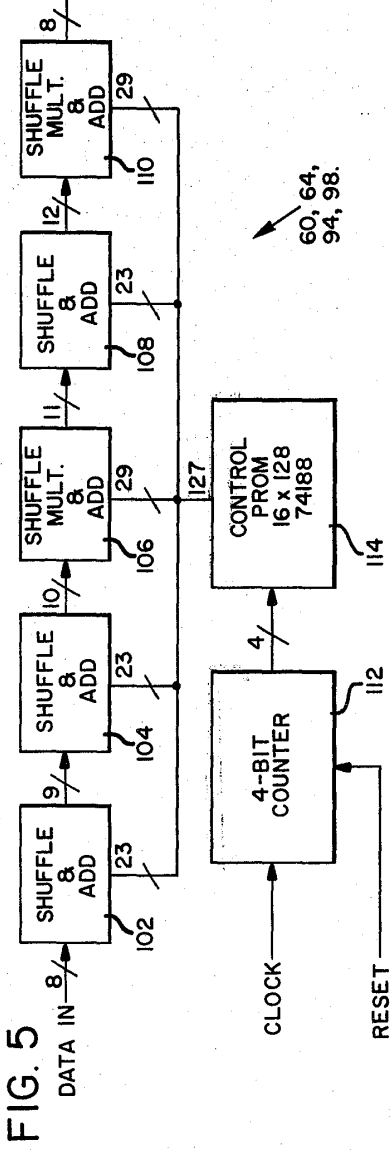

FIG. 5

60, 64, 94, 98.

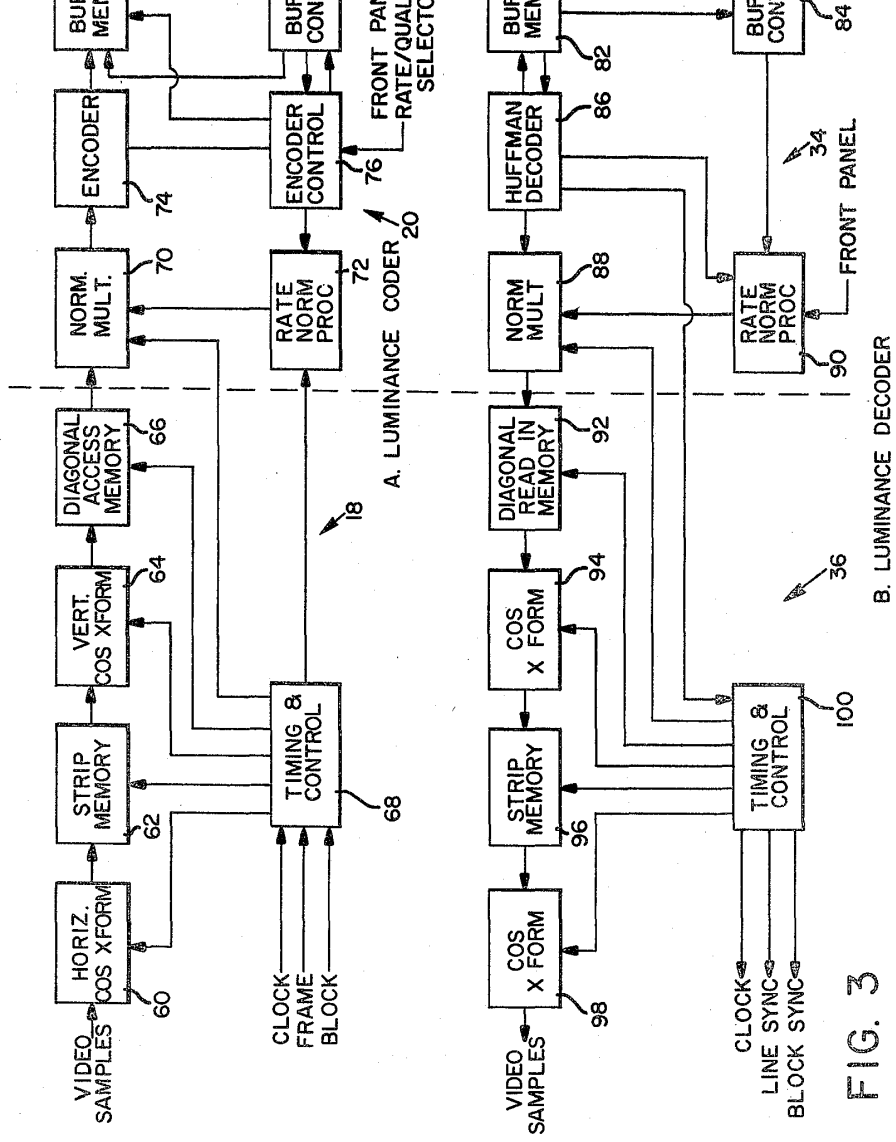
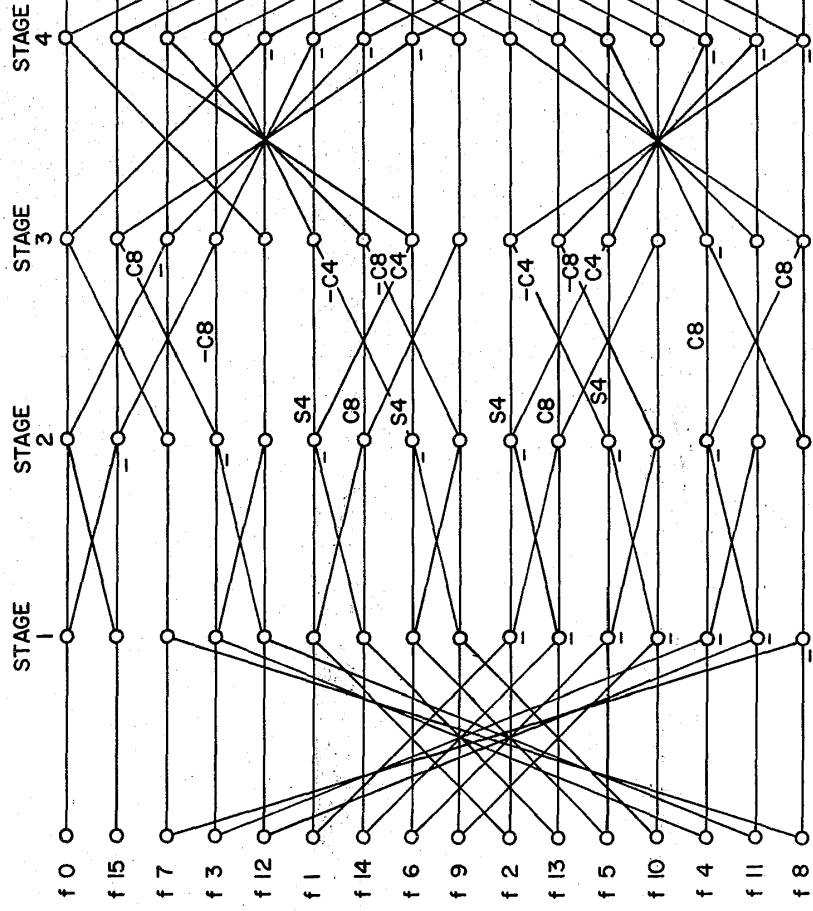

FIG. 3

FIG. 4



# Explore Litigation Insights

Docket Alarm provides insights to develop a more informed litigation strategy and the peace of mind of knowing you're on top of things.

## Real-Time Litigation Alerts



Keep your litigation team up-to-date with **real-time alerts** and advanced team management tools built for the enterprise, all while greatly reducing PACER spend.

Our comprehensive service means we can handle Federal, State, and Administrative courts across the country.

## Advanced Docket Research



With over 230 million records, Docket Alarm's cloud-native docket research platform finds what other services can't. Coverage includes Federal, State, plus PTAB, TTAB, ITC and NLRB decisions, all in one place.

Identify arguments that have been successful in the past with full text, pinpoint searching. Link to case law cited within any court document via Fastcase.

## Analytics At Your Fingertips



Learn what happened the last time a particular judge, opposing counsel or company faced cases similar to yours.

Advanced out-of-the-box PTAB and TTAB analytics are always at your fingertips.

## API

Docket Alarm offers a powerful API (application programming interface) to developers that want to integrate case filings into their apps.

## LAW FIRMS

Build custom dashboards for your attorneys and clients with live data direct from the court.

Automate many repetitive legal tasks like conflict checks, document management, and marketing.

## FINANCIAL INSTITUTIONS

Litigation and bankruptcy checks for companies and debtors.

## E-DISCOVERY AND LEGAL VENDORS

Sync your system to PACER to automate legal marketing.