

FOREWARD

The National Telecommunications Conference for 1976 takes place in Dallas, Texas. The Conference theme, "Communications and Knowledge: Partners in Progress" emphasizes the importance of communications and knowledge both in the progress of our society and within the conference. In providing these stimulating opportunities through their 2300+ communications technology. The technical program consists of 17 technical sessions and one session depicting professional activities directed by the IEEE. The technical sessions offer more than 200 papers including the wide area of an international communications community. Two panel discussions provide a range of views on subjects where public policy is involved.

The educational aspects of the conference are highlighted by the NTC '76 sponsored session, "A New 4000 Channel Undersea Cable System," which describes the system jointly developed by Great Britain, France and the USA, and by papers from 81 authors from outside the USA.

Conference Record

This conference record contains the proceedings of the 1976 National Telecommunications Conference (NTC '76). The record is published in two volumes, Volume I and Volume II. The record is published in two volumes, Volume I and Volume II. The record is published in two volumes, Volume I and Volume II.

Other sessions in the technical program include a focus on digital system performance, engineering, and economic considerations of the 4000 channel undersea cable system. The program also includes a focus on digital system performance, engineering, and economic considerations of the 4000 channel undersea cable system.

Other sessions in the technical program include a focus on digital system performance, engineering, and economic considerations of the 4000 channel undersea cable system. The program also includes a focus on digital system performance, engineering, and economic considerations of the 4000 channel undersea cable system.

Other sessions in the technical program include a focus on digital system performance, engineering, and economic considerations of the 4000 channel undersea cable system. The program also includes a focus on digital system performance, engineering, and economic considerations of the 4000 channel undersea cable system.

The NTC '76 Technical Program Committee, chaired by Mr. E. G. Raymond and assisted by Mr. A. J. Sussner, vice Chairman and the many Session Organizers, whose 1950 proposal is a testament to the success of the conference.

Volume I

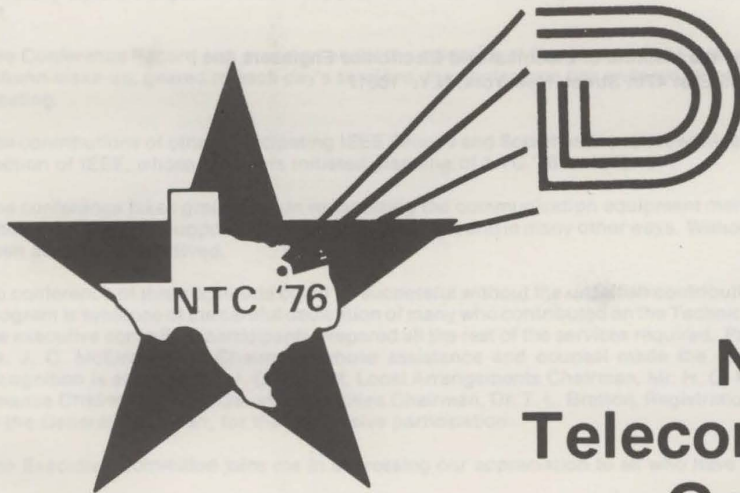

1976 National Telecommunications Conference

Communications and Knowledge,
Partners in Progress

Copyright © 1976 by the Institute of Electrical and Electronics Engineers, Inc.,
345 East 47th Street, New York, N.Y. 10017

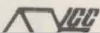

IEEE Catalog Number
78 CH 1149-4 CSCB

Conference Record

**Conference Record
1976 National Telecommunications Conference
(NTC 76)**

TK
5101
A1
N374
1976
v.1

Volume 1

Copyright © 1976 by the Institute of Electrical and Electronics Engineers, Inc.,
345 East 47th Street, New York, N.Y. 10017

1976
National
Telecommunications
Conference

Communications and Knowledge,
Partners in Progress

Library of Congress Catalog Card Number: 57-20724
IEEE Catalog Number 76CH1149-4 CSCB

COMPOSITE INTERFRAME CODING OF NTSC COLOR TELEVISION SIGNALS

Tatsuo Ishiguro, Kazumoto Iinuma, Yukihiro Iijima,
Toshio Koga, Shintaro Azami and Takayoshi Mune

Nippon Electric Company Ltd.

ABSTRACT

This paper describes an interframe codec which directly encodes composite NTSC color television signals at a transmission bit rate of 16 - 32 Mb/s for use as high quality television transmission. The coding principle is based on transmitting a higher order differential PCM signal of frame difference with a variable length coding. As methods of suppressing unwanted significant picture elements, a compensation for sub-carrier phase inversion between frames and a nonlinear function in the coding loop are adopted. For signals with large amount of motions, a sub-Nyquist sampling is used to reduce coding bit rate.

The codec is transparent for the composite video signal, providing high color fidelity no resolution loss and wide band (5 MHz) capability. A codec, which is named NETEC-22H, is constructed.

INTRODUCTION

Interframe coding is expected as a powerful method for realizing a television transmission with very low bit rate.¹⁻⁴ NETEC 6/16 system^{2,3} demonstrated that, although pictures were restricted to those with a little motions as conference television signals, NTSC color television signals could be transmitted at 6 Mbit/sec and that, at 16 Mbit/sec, most of broadcast television pictures could be transmitted with good picture quality. However, the coding performances were not sufficient in the sense

that a jerkiness was caused for violent motion and that the separate component coding produced small deteriorations in resolution and color fidelity. In order to avoid these deteriorations, a composite coding must be applied to interframe coding. The composite coding has an advantage of preserving strictly the waveform of the signals; video, sync, color burst, VITS, standard test signals, etc.

This paper presents a composite interframe coding system aiming at the very high quality with a relatively high bit rate of 16 to 32 Mbit/sec. An algorithm and coding performances are discussed. A codec, named NETEC-22H, is described briefly.

ENCODING ALGORITHM

System block diagram

NETEC-22H system block diagram is shown in Figure 1. An input composite NTSC color television signal is converted into an 8 bit PCM signal by an analog-to-digital converter. The PCM signal is encoded into a reduced rate coded words with 2 ~ 3 bits/sample on an average through a digital signal processing followed.

A pre-processing circuit makes compensation for sub-carrier phase inversion between frames, an interframe predictive coder removes redundancy from the signal, and a variable length coder removes redundancy from the codes representing the prediction error. The compressed data are once stored in a

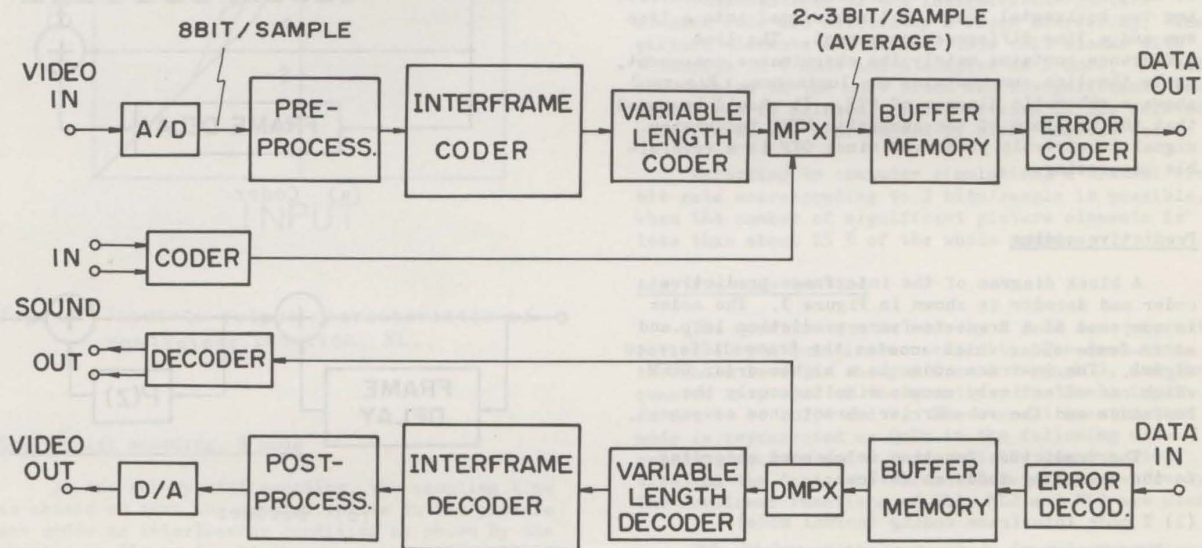

Fig. 1 NETEC-22H system block diagram.

buffer memory and then transmitted through an error correcting coder to a line. At the decoder, the compressed data is decoded into the PCM signal through the reverse process, and the PCM signal is converted into the analog composite NTSC color television signal by a digital-to-analog converter. Since the digital processing is designed principally to preserve the waveform, the codec is transparent for the composite video signal.

Sampling frequency

In the composite coding, the sampling frequency must be higher than double the NTSC television signal bandwidth of 4.2 MHz, and is chosen to be 10.76 MHz ($684 f_h$, f_h : horizontal sync frequency) in normal mode.

On the other hand, in interframe coding a sub-sampling, or halving the sampling frequency, is usually used to avoid the buffer overflow when pictures have a large amount of motions. However, the sub-sampling causes an apparent picture quality degradation, which will not be permitted in the high quality encoding system.

In NETEC-22H system, a sub-Nyquist encoding with a sampling rate of 7.16 MHz ($456 f_h$), about double the sub-carrier frequency, is adopted in stead of the sub-sampling. Aliasing components can be removed by means of a comb filtering, and the picture quality degradations are hardly seen.

Pre-processing, OTF

As long as frame-to-frame prediction is limited to the use of only one frame delay, the sub-carrier chrominance component remains in the frame difference signal because of the sub-carrier phase difference of 180° between succeeding frames. Compensation for the phase inversion is made by first separating the composite signal into luminance and chrominance components and then inverting the polarity of the chrominance component frame by frame.

In the pre-processing circuit, the separation is made by an orthogonal transformation, OTF converting two horizontal scanning lines signal into a line sum and a line difference component. The line difference contains mainly the chrominance component, while the line sum contains the luminance. Figure 2 shows a schematic diagram of OTF. It should be noted that the waveform of the composite NTSC television signal is strictly preserved since OTF is a reversible processing.

Predictive coding

A block diagram of the interframe predictive coder and decoder is shown in Figure 3. The coder is composed of a frame-to-frame prediction loop and an in-frame coder which encodes the frame difference signal. The in-frame coder is a higher order DPCM which can effectively encode simultaneously the luminance and the sub-carrier chrominance component.

The prediction function is changed according to the operating modes as follows:

- (1) T mode interframe coding (normal mode):
HO-DPCM of the frame difference ($P(z)=z^{-3}$).
- (2) T mode in-frame coding (refreshing or transient S/T) HO-DPCM ($P(z)=z^{-3}$)

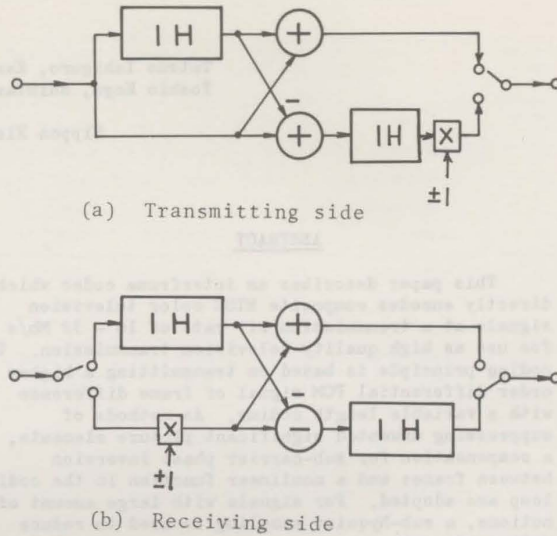

Fig. 2 Orthogonal transformation, OTF.

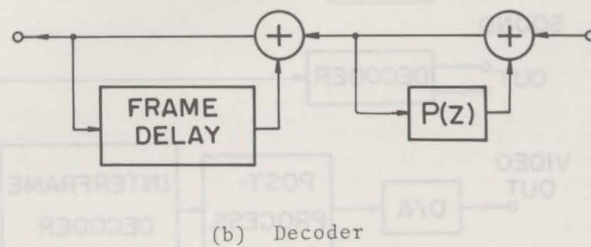
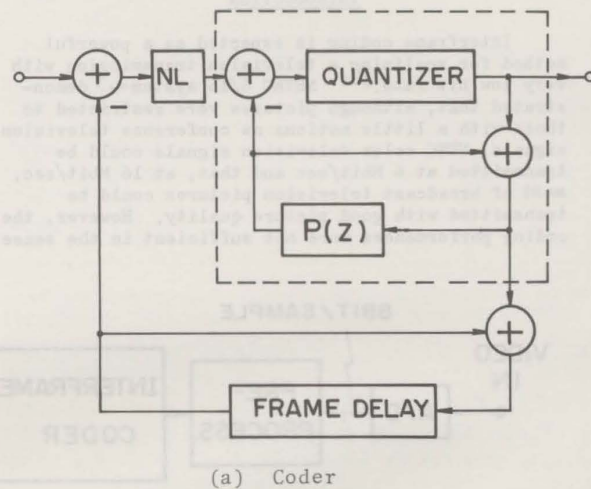

Fig. 3 Interframe predictive coder and decoder block diagram.

- (3) S mode in-frame coding,
 Sub-Nyquist HO-DPCM ($P(Z)=0.5z^{-1}+z^{-2}-0.5z^{-3}$).

A nonlinear function NL is placed into the frame difference path, taking a key role in improving the coding performances. The nonlinear function has an input-to-output relation as shown in Figure 4. The transfer gain is less than unity for the small input amplitude and unity for the large amplitude.

When the gain of the frame difference path is less than unity, the transfer function from the interframe predictive coder input to the quantizer has a recursive type low pass characteristic along the temporal axis. The low pass filtering suppresses feedbacked quantization noise which causes unwanted significant picture elements even for still pictures. Random noise in the input signal is also suppressed through the temporal low pass filtering. On the contrary, the temporal low pass filtering gives rise to a blurring of the moving objects in the picture.

The nonlinear characteristic as shown in Figure 4 is useful because small amplitude noises on still part of picture are suppressed through the temporal low pass filtering and large amplitude frame differences caused by motions are not almost affected.

The nonlinear function causes a blurring of moving picture edges with small brightness change. This effect is hardly perceived in NL1, but is occasionally seen in NL3.

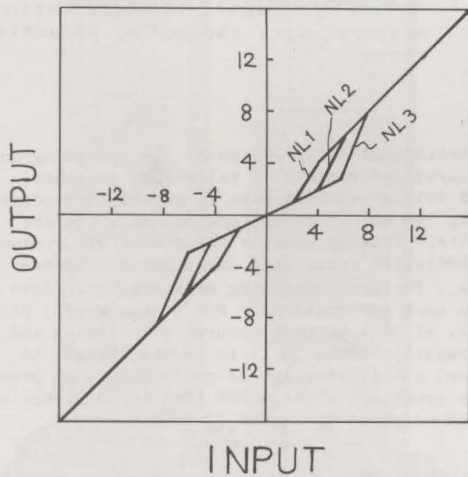
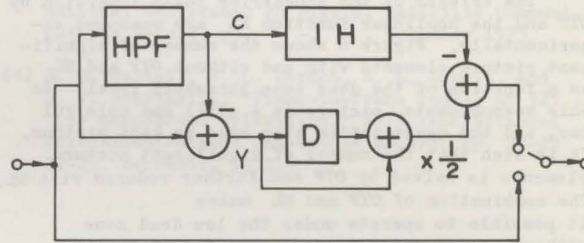
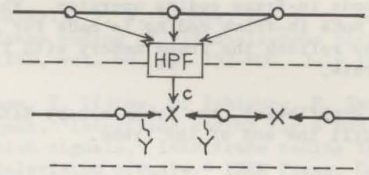

Fig. 4 Input-to-output characteristic of nonlinear function, NL.

Sub-Nyquist encoding, S mode

In the sub-Nyquist encoding, the sampling time is chosen so that the sampled points in the picture are under an interleaving condition as shown by the circles in Figure 5. At the receiving side, aliasing components removal is made by using a comb filtering as shown in Figure 5. The samples designated by x are interpolated from the adjacent samples.



INTERPOLATION COMB FILTER

Fig. 5 Sub-Nyquist encoding, S mode.

Variable length coding

In the interframe predictive coding, the prediction error is quantized and coded into 6 bits/sample code. The codes are transformed into reduced bit rate data through a variable length coder.

The code word length is from 1 through 12. The zero amplitude representing insignificant picture element is given by the unit bit code, and significant pels are given by 3 ~ 12 bits code.

Continuations of the insignificant picture element code are deleted by a block addressing. The picture elements are divided into unit blocks with 9 samples in T mode and 6 samples in S mode. If all the samples in the unit block are insignificant, the unit block is deleted. The positions of the deleted unit blocks are represented by block address codes.

According to computer simulation, a transmission bit rate corresponding to 2 bits/sample is possible, when the number of significant picture elements is less than about 25 % of the whole samples.

Adaptive mode control

The quantization is made by a dead zone circuit followed by a quantization circuit. The dead zone threshold level is changed from 1 through 3, and the quantum step size of the quantizer for small input is set to be 1,2,4 and 6. The overall quantization mode is represented as QmDn in the following discussion, where m and n represent the quantum step size and the dead zone threshold level, respectively. The nonlinear functions of NL1, NL2 and NL3 are used.

The choice of the parameters is made depending on the buffer memory occupancy. As the buffer occupancy increases, the quantization parameters is changed from the fine to the coarse ones.

Explore Litigation Insights

Docket Alarm provides insights to develop a more informed litigation strategy and the peace of mind of knowing you're on top of things.

Real-Time Litigation Alerts



Keep your litigation team up-to-date with **real-time alerts** and advanced team management tools built for the enterprise, all while greatly reducing PACER spend.

Our comprehensive service means we can handle Federal, State, and Administrative courts across the country.

Advanced Docket Research



With over 230 million records, Docket Alarm's cloud-native docket research platform finds what other services can't. Coverage includes Federal, State, plus PTAB, TTAB, ITC and NLRB decisions, all in one place.

Identify arguments that have been successful in the past with full text, pinpoint searching. Link to case law cited within any court document via Fastcase.

Analytics At Your Fingertips



Learn what happened the last time a particular judge, opposing counsel or company faced cases similar to yours.

Advanced out-of-the-box PTAB and TTAB analytics are always at your fingertips.

API

Docket Alarm offers a powerful API (application programming interface) to developers that want to integrate case filings into their apps.

LAW FIRMS

Build custom dashboards for your attorneys and clients with live data direct from the court.

Automate many repetitive legal tasks like conflict checks, document management, and marketing.

FINANCIAL INSTITUTIONS

Litigation and bankruptcy checks for companies and debtors.

E-DISCOVERY AND LEGAL VENDORS

Sync your system to PACER to automate legal marketing.