

Assumptions:

1. One-dimensional conduction in r .
2. Constant properties.

Analysis:

1. To determine whether the lumped capacitance method can be used, the Biot number is calculated. From Equation 5.10, with $L_c = r_o/3$,

$$Bi = \frac{h_a r_o}{3k} = \frac{10 \text{ W/m}^2 \cdot \text{K} \times 0.005 \text{ m}}{3 \times 20 \text{ W/m} \cdot \text{K}} = 8.33 \times 10^{-4}$$

Accordingly, the lumped capacitance method may be used, and the temperature is nearly uniform throughout the sphere. From Equation 5.5 it follows that

$$t_a = \frac{\rho V c}{h_a A_s} \ln \frac{\theta_i}{\theta_a} = \frac{\rho r_o c}{3 h_a} \ln \frac{T_i - T_\infty}{T_a - T_\infty}$$

where $V = (4/3)\pi r_o^3$ and $A_s = 4\pi r_o^2$. Hence

$$t_a = \frac{3000 \text{ kg/m}^3 \times 0.005 \text{ m} \times 1000 \text{ J/kg} \cdot \text{K}}{3 \times 10 \text{ W/m}^2 \cdot \text{K}} \ln \frac{400 - 20}{335 - 20} = 94 \text{ s}$$

2. To determine whether the lumped capacitance method may also be used for the second step of the cooling process, the Biot number is again calculated. In this case

$$Bi = \frac{h_w r_o}{3k} = \frac{6000 \text{ W/m}^2 \cdot \text{K} \times 0.005 \text{ m}}{3 \times 20 \text{ W/m} \cdot \text{K}} = 0.50$$

and the lumped capacitance method is not appropriate. However, to an excellent approximation, the temperature of the sphere is uniform at $t = t_a$ and the Heisler charts may be used for the calculations from $t = t_a$ to $t = t_a + t_w$. Using Figure 5.14 with

$$Bi^{-1} = \frac{k}{h_w r_o} = \frac{20 \text{ W/m} \cdot \text{K}}{6000 \text{ W/m}^2 \cdot \text{K} \times 0.005 \text{ m}} = 0.67$$

$$\frac{\theta_o}{\theta_i} = \frac{T_o - T_\infty}{T_i - T_\infty} = \frac{50 - 20}{335 - 20} = 0.095$$

it follows that $Fo \approx 0.80$, and

$$t_w = Fo \frac{r_o^2}{\alpha} \approx 0.80 \frac{(0.005 \text{ m})^2}{6.66 \times 10^{-6} \text{ m}^2/\text{s}} \approx 3.0 \text{ s}$$

Comments:

1. If the temperature distribution in the sphere at the conclusion of step 1 were not uniform, the Heisler chart could not be used for the calculations of step 2.
2. The surface temperature of the sphere at the conclusion of step 2 may be obtained from Figure 5.15. With

$$Bi^{-1} = 0.67 \quad \text{and} \quad \frac{r}{r_o} = 1$$

$$\frac{\theta(r_o)}{\theta_o} = \frac{T(r_o) - T_\infty}{T_o - T_\infty} \approx 0.52$$

Hence

$$T(r_o) \approx 20^\circ\text{C} + 0.52(50 - 20)^\circ\text{C} \approx 36^\circ\text{C}$$

The variation of the center and surface temperature with time is then as follows.

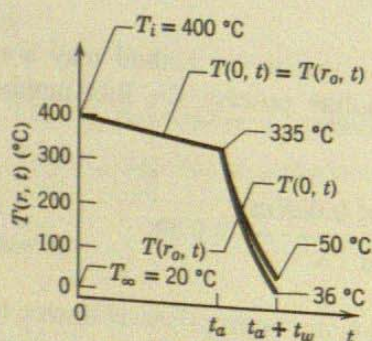

3. For the step 2 transient process in water, the one-term approximation is appropriate for determining the time t_w at which the center temperature reaches 50°C , that is, $T(0, t_w) = 50^\circ\text{C}$. Rearranging Equation 5.50c,

$$Fo = -\frac{1}{\zeta_1^2} \ln \left[\frac{\theta_o^*}{C_1} \right] = -\frac{1}{\zeta_1^2} \ln \left[\frac{1}{C_1} \times \frac{T(0, t_w) - T_\infty}{T_i - T_\infty} \right]$$

Using Table 5.1 to obtain the coefficients for $Bi = 1/0.67 = 1.50$ ($C_1 = 1.376$ and $\zeta_1 = 1.800$ rad) and substituting appropriate tempera-

tures, it follows that

$$Fo = -\frac{1}{(1.800 \text{ rad})^2} \ln \left[\frac{1}{1.376} \times \frac{(50 - 20)^\circ\text{C}}{(335 - 20)^\circ\text{C}} \right] = 0.82$$

Substituting for r_o and α , it follows that $t_w = 3.1$ s, which is within 3% of the value of 3.0 s obtained from the Heisler chart.

5.7 THE SEMI-INFINITE SOLID

Another simple geometry for which analytical solutions may be obtained is the *semi-infinite solid*. Since such a solid extends to infinity in all but one direction, it is characterized by a single identifiable surface (Figure 5.17). If a sudden change of conditions is imposed at this surface, transient, one-dimensional conduction will occur within the solid. The semi-infinite solid provides a *useful idealization* for many practical problems. It may be used to determine transient heat transfer near the surface of the earth or to approximate the transient response of a finite solid, such as a thick slab. For this second situation the approximation would be reasonable for the early portion of the transient, during which temperatures in the slab interior (well removed from the surface) are uninfluenced by the change in surface conditions.

The heat equation for transient conduction in a semi-infinite solid is given by Equation 5.26. The initial condition is prescribed by Equation 5.27, and the interior boundary condition is of the form

$$T(\infty, t) = T_i \tag{5.53}$$

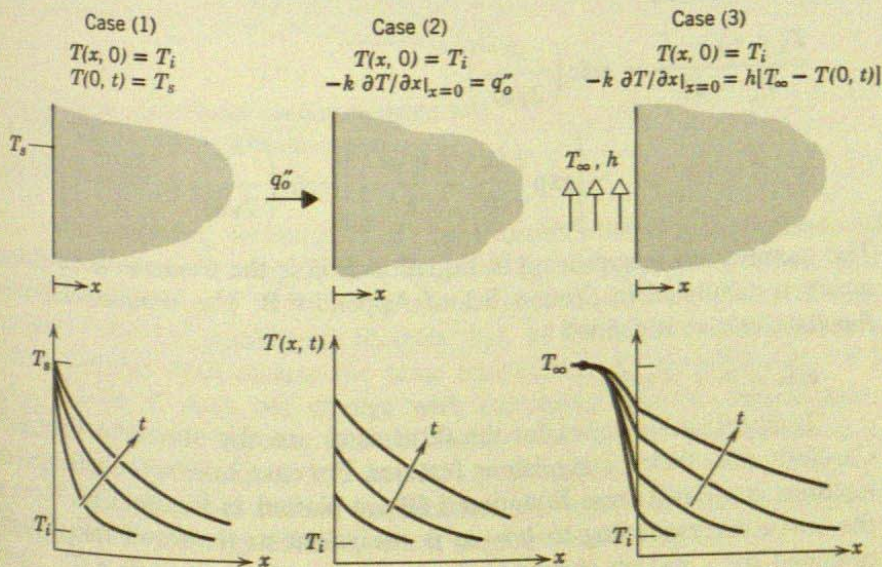

Figure 5.17 Transient temperature distributions in a semi-infinite solid for three surface conditions: constant surface temperature, constant surface heat flux, and surface convection.

LIBRARY U. OF I. URBANA-CHAMPAIGN

Closed-form solutions have been obtained for three important surface conditions, instantaneously applied at $t = 0$ [1, 2]. These conditions are shown in Figure 5.17. They include application of a constant surface temperature $T_s \neq T_i$, application of a constant surface heat flux q''_o , and exposure of the surface to a fluid characterized by $T_\infty \neq T_i$ and the convection coefficient h . The solutions are summarized as follows.

Case 1 Constant Surface Temperature

$$T(0, t) = T_s \quad (5.54)$$

$$\frac{T(x, t) - T_s}{T_i - T_s} = \operatorname{erf}\left(\frac{x}{2\sqrt{\alpha t}}\right) \quad (5.55)$$

$$q''_s(t) = -k \left. \frac{\partial T}{\partial x} \right|_{x=0} = \frac{k(T_s - T_i)}{\sqrt{\pi \alpha t}} \quad (5.56)$$

Case 2 Constant Surface Heat Flux

$$q''_s = q''_o \quad (5.57)$$

$$T(x, t) - T_i = \frac{2q''_o(\alpha t/\pi)^{1/2}}{k} \exp\left(\frac{-x^2}{4\alpha t}\right) - \frac{q''_o x}{k} \operatorname{erfc}\left(\frac{x}{2\sqrt{\alpha t}}\right) \quad (5.58)$$

Case 3 Surface Convection

$$-k \left. \frac{\partial T}{\partial x} \right|_{x=0} = h[T_\infty - T(0, t)] \quad (5.59)$$

$$\frac{T(x, t) - T_i}{T_\infty - T_i} = \operatorname{erfc}\left(\frac{x}{2\sqrt{\alpha t}}\right) - \left[\exp\left(\frac{hx}{k} + \frac{h^2 \alpha t}{k^2}\right) \right] \operatorname{erfc}\left(\frac{x}{2\sqrt{\alpha t}} + \frac{h\sqrt{\alpha t}}{k}\right) \quad (5.60)$$

The quantity $\operatorname{erf} w$ appearing in Equation 5.55 is the *Gaussian error function*, which is tabulated in Section B.1 of Appendix B. The *complementary error function*, $\operatorname{erfc} w$, is defined as

$$\operatorname{erfc} w \equiv 1 - \operatorname{erf} w$$

Temperature histories for the three cases are also shown in Figure 5.17. Carefully note their distinguishing features. For case 3 the specific temperature histories computed from Equation 5.60 are plotted in Figure 5.18. Note that the curve corresponding to $h = \infty$ is equivalent to the result that would be obtained for a sudden change in the *surface temperature* to $T_s = T_\infty$. That is, for $h = \infty$ the second term on the right-hand side of Equation 5.60 goes to zero, and the result is equivalent to Equation 5.55.

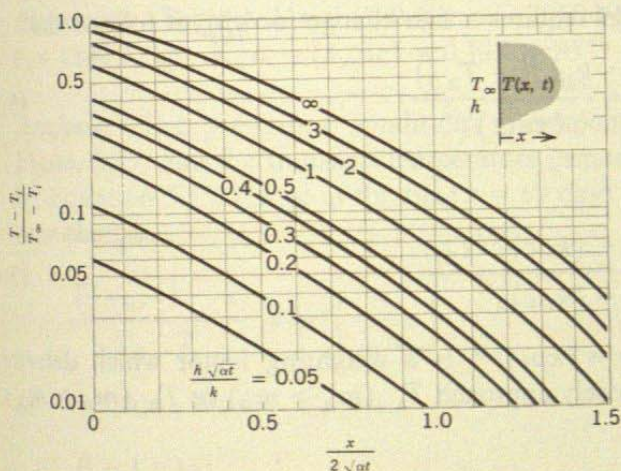

Figure 5.18 Temperature histories in a semi-infinite solid with surface convection [2]. Adapted with permission.

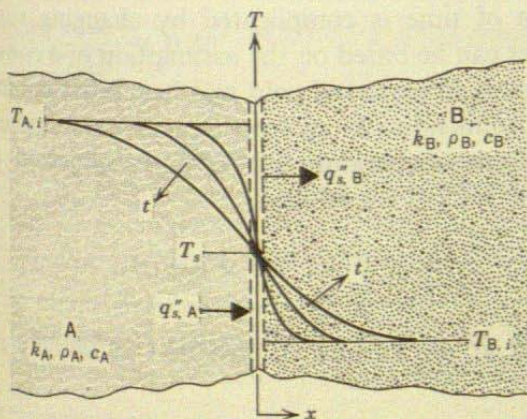

Figure 5.19 Interfacial contact between two semi-infinite solids at different initial temperatures.

An interesting permutation of case 1 results when two semi-infinite solids, initially at uniform temperatures $T_{A,i}$ and $T_{B,i}$, are placed in contact at their free surfaces (Figure 5.19). If the contact resistance is negligible, the requirement of thermal equilibrium dictates that, at the instant of contact ($t = 0$), both surfaces must assume the same temperature T_s , for which $T_{B,i} < T_s < T_{A,i}$. Since T_s does not change with increasing time, it follows that the transient thermal response and the surface heat flux of each of the solids is determined by Equations 5.55 and 5.56, respectively.

The equilibrium surface temperature of Figure 5.19 may be determined from a surface energy balance, which requires that

$$q''_{s,A} = q''_{s,B} \tag{5.61}$$

Substituting from Equation 5.56 for $q''_{s,A}$ and $q''_{s,B}$ and recognizing that the x

LIBRARY U. OF I. URBANA-CHAMPAIGN

coordinate of Figure 5.19 requires a sign change for $q''_{s,A}$, it follows that

$$\frac{-k_A(T_s - T_{A,i})}{(\pi\alpha_A t)^{1/2}} = \frac{k_B(T_s - T_{B,i})}{(\pi\alpha_B t)^{1/2}} \quad (5.62)$$

or, solving for T_s ,

$$T_s = \frac{(k\rho c)_A^{1/2}T_{A,i} + (k\rho c)_B^{1/2}T_{B,i}}{(k\rho c)_A^{1/2} + (k\rho c)_B^{1/2}} \quad (5.63)$$

Hence, the quantity $m \equiv (k\rho c)^{1/2}$ is a weighting factor which determines whether T_s will more closely approach $T_{A,i}$ ($m_A > m_B$) or $T_{B,i}$ ($m_B > m_A$).

EXAMPLE 5.4

In laying water mains, utilities must be concerned with the possibility of freezing during cold periods. Although the problem of determining the temperature in soil as a function of time is complicated by changing surface conditions, reasonable estimates can be based on the assumption of a constant surface temperature over a prolonged period of cold weather. What minimum burial depth x_m would you recommend to avoid freezing under conditions for which soil, initially at a uniform temperature of 20°C, is subjected to a constant surface temperature of -15°C for 60 days?

SOLUTION

Known: Temperature imposed at the surface of soil that is initially at 20°C.

Find: The depth x_m to which the soil has frozen after 60 days.

Schematic:

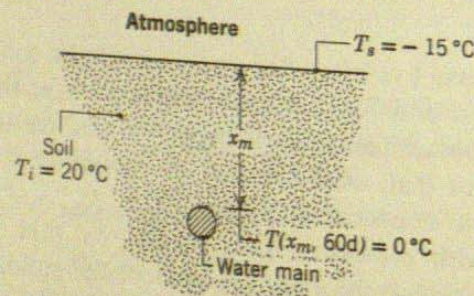

Assumptions:

1. One-dimensional conduction in x .
2. Soil is a semi-infinite medium.
3. Constant properties.

follows that

(5.62)

Properties: Table A.3, soil (300 K): $\rho = 2050 \text{ kg/m}^3$, $k = 0.52 \text{ W/m} \cdot \text{K}$, $c = 1840 \text{ J/kg} \cdot \text{K}$, $\alpha = (k/\rho c) = 0.138 \times 10^{-6} \text{ m}^2/\text{s}$.

Analysis: The prescribed conditions correspond to those of case 1 of Figure 5.17, and the transient temperature response of the soil is governed by Equation 5.55. Hence at the time $t = 60$ days after the surface temperature change,

(5.63)

$$\frac{T(x_m, t) - T_s}{T_i - T_s} = \text{erf}\left(\frac{x_m}{2\sqrt{\alpha t}}\right)$$

or

$$\frac{0 - (-15)}{20 - (-15)} = 0.429 = \text{erf}\left(\frac{x_m}{2\sqrt{\alpha t}}\right)$$

Hence from Appendix B.1

$$\frac{x_m}{2\sqrt{\alpha t}} = 0.40$$

and

$$x_m = 0.80\sqrt{\alpha t} = 0.80(0.138 \times 10^{-6} \text{ m}^2/\text{s} \times 60 \text{ days} \times 24 \text{ h/day} \times 3600 \text{ s/h})^{1/2} = 0.68 \text{ m} \quad \triangleleft$$

Comments: The properties of soil are highly variable, depending on the nature of the soil and its moisture content.

5.8 MULTIDIMENSIONAL EFFECTS

Transient problems are frequently encountered for which two- and even three-dimensional effects are significant. Solution to a class of such problems can be obtained from the one-dimensional results of Sections 5.6 and 5.7.

Consider immersing the *short* cylinder of Figure 5.20, which is initially at a uniform temperature T_i , in a fluid of temperature $T_\infty \neq T_i$. Because the length and diameter are comparable, the subsequent transfer of energy by conduction will be significant for both the r and x coordinate directions. The temperature within the cylinder will therefore depend on r , x , and t .

Assuming constant properties and no generation, the appropriate form of the heat equation is, from Equation 2.20,

$$\frac{1}{r} \frac{\partial}{\partial r} \left(r \frac{\partial T}{\partial r} \right) + \frac{\partial^2 T}{\partial x^2} = \frac{1}{\alpha} \frac{\partial T}{\partial t}$$

LIBRARY U. OF I. URBANA-CHAMPAIGN

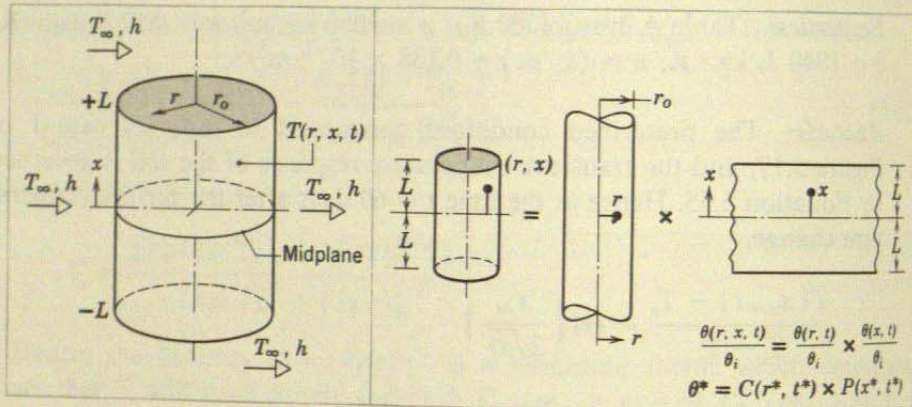

Figure 5.20 Two-dimensional, transient conduction in a short cylinder. (a) Geometry. (b) Form of the product solution.

where x has been used in place of z to designate the axial coordinate. A closed-form solution to this equation may be obtained by the separation of variables method. Although we will not consider the details of this solution, it is important to note that the end result may be expressed in the following form.

$$\frac{T(r, x, t) - T_\infty}{T_i - T_\infty} = \frac{T(x, t) - T_\infty}{T_i - T_\infty} \Big|_{\text{Plane wall}} \cdot \frac{T(r, t) - T_\infty}{T_i - T_\infty} \Big|_{\text{Infinite cylinder}}$$

That is, the two-dimensional solution may be expressed as a *product* of one-dimensional solutions that correspond to those for a plane wall of thickness $2L$ and an infinite cylinder of radius r_0 . These solutions are available from Figures 5.8 and 5.9 for the plane wall and Figures 5.11 and 5.12 for the infinite cylinder. They are also available from the one-term approximations given by Equations 5.40 and 5.49.

Results for other multidimensional geometries are summarized in Figure 5.21. In each case the multidimensional solution is prescribed in terms of a product involving one or more of the following one-dimensional solutions.

$$S(x, t) \equiv \frac{T(x, t) - T_\infty}{T_i - T_\infty} \Big|_{\text{Semi-infinite solid}} \quad (5.64)$$

$$P(x, t) \equiv \frac{T(x, t) - T_\infty}{T_i - T_\infty} \Big|_{\text{Plane wall}} \quad (5.65)$$

$$C(r, t) \equiv \frac{T(r, t) - T_\infty}{T_i - T_\infty} \Big|_{\text{Infinite cylinder}} \quad (5.66)$$

The x coordinate for the semi-infinite solid is measured from the surface.

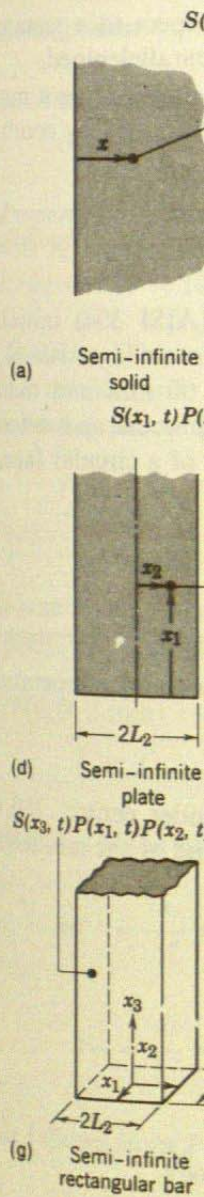

Figure 5.21 Solutions for multidimensional geometries.

whereas for the plate the coordinate x_2 is measured from the surface. The multidimensional temperature $T(x_1, x_2, x_3, t)$ is then, for a rectangular bar of thickness $2L_2$ in the x_2 direction and of length $2L_3$ in the x_3 direction,

$$\frac{T(x_1, x_2, x_3, t) - T_\infty}{T_i - T_\infty} = S(x_1, t) P(x_2, t) C(x_3, t)$$

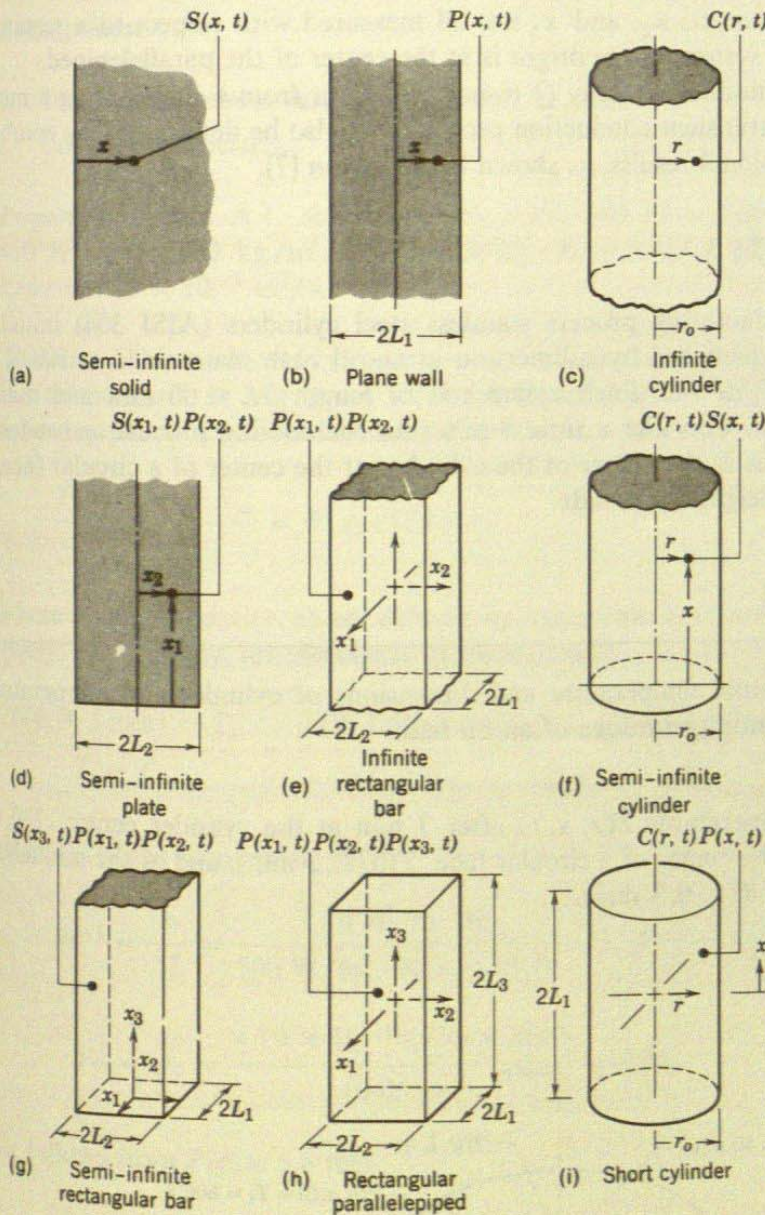

Figure 5.21 Solutions for multidimensional systems expressed as products of one-dimensional results.

whereas for the plane wall it is measured from the midplane. In using Figure 5.21 the coordinate origins should be carefully noted. The transient, three-dimensional temperature distribution in a rectangular parallelepiped, Figure 5.21h, is then, for example, the product of three one-dimensional solutions for plane walls of thicknesses $2L_1$, $2L_2$, and $2L_3$. That is,

$$\frac{T(x_1, x_2, x_3, t) - T_\infty}{T_i - T_\infty} = P(x_1, t) \cdot P(x_2, t) \cdot P(x_3, t)$$

LIBRARY U. OF I. URBANA-CHAMPAIGN

The distances x_1 , x_2 , and x_3 are all measured with respect to a rectangular coordinate system whose origin is at the center of the parallelepiped.

The amount of energy Q transferred to or from a solid during a multidimensional transient conduction process may also be determined by combining one-dimensional results, as shown by Langston [7].

EXAMPLE 5.5

In a manufacturing process stainless steel cylinders (AISI 304) initially at 600 K are quenched by submersion in an oil bath maintained at 300 K with $h = 500 \text{ W/m}^2 \cdot \text{K}$. Each cylinder is of length $2L = 60 \text{ mm}$ and diameter $D = 80 \text{ mm}$. Consider a time 3 min into the cooling process and determine temperatures at the center of the cylinder, at the center of a circular face, and at the midheight of the side.

SOLUTION

Known: Initial temperature and dimensions of cylinder and temperature and convection conditions of an oil bath.

Find: Temperatures $T(r, x, t)$ after 3 min at the cylinder center, $T(0, 0, 3 \text{ min})$, at the center of a circular face, $T(0, L, 3 \text{ min})$, and at the midheight of the side, $T(r_o, 0, 3 \text{ min})$.

Schematic:

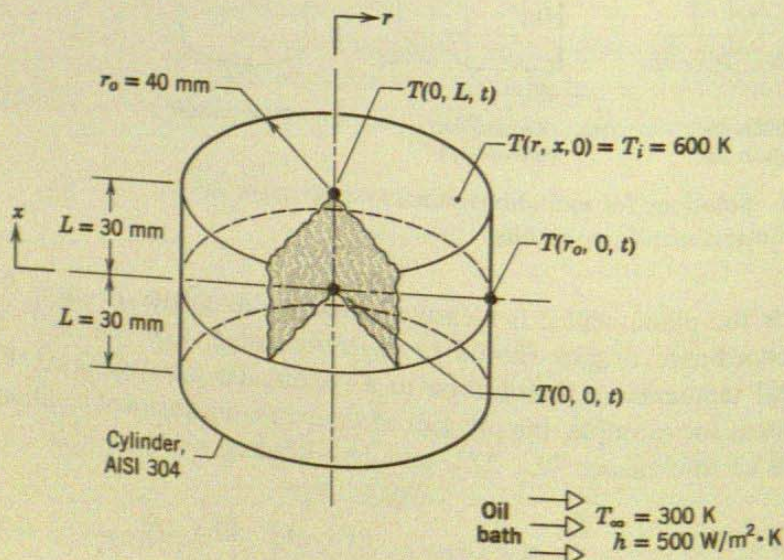

Assumptions:

1. Two-dimensional
2. Constant

Properties:

450 K]: $\rho =$
 $k/\rho c = 4.19$

Analysis: T
 the tempera
 following pr

$$\frac{T(r, x, t) - T_\infty}{T_i - T_\infty} = P(r_o, r) \cdot C(x, x_o) \cdot D(t)$$

where $P(x, t)$
 tively. Accor

$$\frac{T(0, 0, 3 \text{ min}) - T_\infty}{T_i - T_\infty} =$$

Hence, for t

$$Bi^{-1} =$$

$$Fo =$$

it follows fr

$$\frac{\theta_o}{\theta_i} = T$$

Similarly, fo

$$Bi^{-1} =$$

$$Fo =$$

Assumptions:

1. Two-dimensional conduction in r and x .
2. Constant properties.

Properties: Table A.1, stainless steel, AISI 304 [$T = (600 + 300)/2 = 450$ K]: $\rho = 7900$ kg/m³, $c = 526$ J/kg · K, $k = 17.4$ W/m · K, $\alpha = k/\rho c = 4.19 \times 10^{-6}$ m²/s.

Analysis: The solid steel cylinder corresponds to case i of Figure 5.21, and the temperature at any point in the cylinder may be expressed as the following product of one-dimensional solutions.

$$\frac{T(r, x, t) - T_\infty}{T_i - T_\infty} = P(x, t)C(r, t)$$

where $P(x, t)$ and $C(r, t)$ are defined by Equations 5.65 and 5.66, respectively. Accordingly, for the center of the cylinder,

$$\frac{T(0, 0, 3 \text{ min}) - T_\infty}{T_i - T_\infty} = \left. \frac{T(0, 3 \text{ min}) - T_\infty}{T_i - T_\infty} \right|_{\text{Plane wall}} \cdot \left. \frac{T(0, 3 \text{ min}) - T_\infty}{T_i - T_\infty} \right|_{\text{Infinite cylinder}}$$

Hence, for the plane wall, with

$$Bi^{-1} = \frac{k}{hL} = \frac{17.4 \text{ W/m} \cdot \text{K}}{500 \text{ W/m}^2 \cdot \text{K} \times 0.03 \text{ m}} = 1.16$$

$$Fo = \frac{\alpha t}{L^2} = \frac{4.19 \times 10^{-6} \text{ m}^2/\text{s} \times 180 \text{ s}}{(0.03 \text{ m})^2} = 0.84$$

it follows from Figure 5.8 that

$$\frac{\theta_o}{\theta_i} = \left. \frac{T(0, 3 \text{ min}) - T_\infty}{T_i - T_\infty} \right|_{\text{Plane wall}} \approx 0.64$$

Similarly, for the infinite cylinder, with

$$Bi^{-1} = \frac{k}{hr_o} = \frac{17.4 \text{ W/m} \cdot \text{K}}{500 \text{ W/m}^2 \cdot \text{K} \times 0.04 \text{ m}} = 0.87$$

$$Fo = \frac{\alpha t}{r_o^2} = \frac{4.19 \times 10^{-6} \text{ m}^2/\text{s} \times 180 \text{ s}}{(0.04 \text{ m})^2} = 0.47$$

it follows from Figure 5.11 that

$$\frac{\theta_o}{\theta_i} = \frac{T(0, 3 \text{ min}) - T_\infty}{T_i - T_\infty} \Big|_{\text{Infinite cylinder}} \approx 0.55$$

Hence, for the center of the cylinder,

$$\frac{T(0, 0, 3 \text{ min}) - T_\infty}{T_i - T_\infty} \approx 0.64 \times 0.55 \approx 0.35$$

$$T(0, 0, 3 \text{ min}) \approx 300 \text{ K} + 0.35(600 - 300) \text{ K} \approx 405 \text{ K}$$

The temperature at the center of a circular face may be obtained from the requirement that

$$\frac{T(0, L, 3 \text{ min}) - T_\infty}{T_i - T_\infty} = \frac{T(L, 3 \text{ min}) - T_\infty}{T_i - T_\infty} \Big|_{\text{Plane wall}} \cdot \frac{T(0, 3 \text{ min}) - T_\infty}{T_i - T_\infty} \Big|_{\text{Infinite cylinder}}$$

where, from Figure 5.9 with $(x/L) = 1$ and $Bi^{-1} = 1.16$,

$$\frac{\theta(L)}{\theta_o} = \frac{T(L, 3 \text{ min}) - T_\infty}{T(0, 3 \text{ min}) - T_\infty} \Big|_{\text{Plane wall}} \approx 0.68$$

Hence

$$\frac{T(L, 3 \text{ min}) - T_\infty}{T_i - T_\infty} \Big|_{\text{Plane wall}} = \frac{T(L, 3 \text{ min}) - T_\infty}{T(0, 3 \text{ min}) - T_\infty} \Big|_{\text{Plane wall}} \cdot \frac{T(0, 3 \text{ min}) - T_\infty}{T_i - T_\infty} \Big|_{\text{Plane wall}}$$

$$\frac{T(L, 3 \text{ min}) - T_\infty}{T_i - T_\infty} \Big|_{\text{Plane wall}} \approx 0.68 \times 0.64 \approx 0.44$$

Hence

$$\frac{T(0, L, 3 \text{ min}) - T_\infty}{T_i - T_\infty} \approx 0.44 \times 0.55 \approx 0.24$$

$$T(0, L, 3 \text{ min}) \approx 300 \text{ K} + 0.24(600 - 300) \text{ K} \approx 372 \text{ K}$$

The temperature at the midheight of the side may be obtained from the requirement that

$$\frac{T(r_o, 0, 3 \text{ min}) - T_\infty}{T_i - T_\infty} = \frac{T(0, 3 \text{ min}) - T_\infty}{T_i - T_\infty} \Big|_{\text{Plane wall}} \cdot \frac{T(r_o, 3 \text{ min}) - T_\infty}{T_i - T_\infty} \Big|_{\text{Infinite cylinder}}$$

where, from Fig

$$\frac{\theta(r_o)}{\theta_o} = \frac{T(r_o, 3 \text{ min}) - T_\infty}{T_i - T_\infty}$$

Hence

$$\frac{T(r_o, 3 \text{ min}) - T_\infty}{T_i - T_\infty}$$

$$\frac{T(r_o, 3 \text{ min}) - T_\infty}{T_i - T_\infty}$$

Hence

$$\frac{T(r_o, 0, 3 \text{ min}) - T_\infty}{T_i - T_\infty}$$

$$T(r_o, 0, 3 \text{ min}) - T_\infty$$

Comments:

1. Verify that $T(0, 0, 3 \text{ min}) \approx 405 \text{ K}$
2. The one-term approximation is less temperature error at midplane than at the center of the cylinder.

$$\theta_o^* = \frac{T(0, 0, 3 \text{ min}) - T_\infty}{T_i - T_\infty}$$

where, with $Fo = 0.1$
With $Fo = 0.1$

$$\frac{\theta_o}{\theta_i} \Big|_{\text{Plane wall}}$$

where, from Figure 5.12 with $(r/r_o) = 1$ and $Bi^{-1} = 0.87$,

$$\frac{\theta(r_o)}{\theta_o} = \frac{T(r_o, 3 \text{ min}) - T_\infty}{T(0, 3 \text{ min}) - T_\infty} \Bigg|_{\text{Infinite cylinder}} \approx 0.61$$

Hence

$$\frac{T(r_o, 3 \text{ min}) - T_\infty}{T_i - T_\infty} \Bigg|_{\text{Infinite cylinder}} = \frac{T(r_o, 3 \text{ min}) - T_\infty}{T(0, 3 \text{ min}) - T_\infty} \Bigg|_{\text{Infinite cylinder}} \cdot \frac{T(0, 3 \text{ min}) - T_\infty}{T_i - T_\infty} \Bigg|_{\text{Infinite cylinder}}$$

$$\frac{T(r_o, 3 \text{ min}) - T_\infty}{T_i - T_\infty} \Bigg|_{\text{Infinite cylinder}} \approx 0.61 \times 0.55 \approx 0.34$$

Hence

$$\frac{T(r_o, 0, 3 \text{ min}) - T_\infty}{T_i - T_\infty} \approx 0.64 \times 0.34 \approx 0.22$$

$$T(r_o, 0, 3 \text{ min}) \approx 300 \text{ K} + 0.22(600 - 300) \text{ K} \approx 366 \text{ K}$$

Comments:

1. Verify that the temperature at the edge of the cylinder is $T(r_o, L, 3 \text{ min}) \approx 345 \text{ K}$.
2. The one-term approximations can be used to calculate the dimensionless temperatures read from the Heisler charts. For the *plane wall*, the midplane temperature can be determined from Equation 5.41

$$\theta_o^* = \frac{\theta_o}{\theta_i} = C_1 \exp(-\zeta_1^2 Fo)$$

where, with $Bi = 0.862$, $C_1 = 1.109$ and $\zeta_1 = 0.814 \text{ rad}$ from Table 5.1. With $Fo = 0.84$,

$$\frac{\theta_o}{\theta_i} \Bigg|_{\text{Plane wall}} = 1.109 \exp[-(0.814 \text{ rad})^2 \times 0.84] = 0.636$$

LIBRARY U. OF I. URBANA-CHAMPAIGN

The surface temperature can be evaluated using Equation 5.40b

$$\frac{\theta^*}{\theta_o^*} = \frac{\theta}{\theta_o} = \cos(\zeta_1 x^*)$$

with $x^* = 1$ to give

$$\frac{\theta^*(1, Fo)}{\theta_o^*} = \frac{\theta(L, t)}{\theta_o} = \cos(0.814 \text{ rad} \times 1) = 0.687$$

For the *infinite cylinder*, the centerline temperature can be determined from Equation 5.49c.

$$\theta_o^* = \frac{\theta_o}{\theta_i} = C_1 \exp(-\zeta_1^2 Fo)$$

where, with $Bi = 1.15$, $C_1 = 1.227$ and $\zeta_1 = 1.307$ from Table 5.1. With $Fo = 0.47$,

$$\left. \frac{\theta_o}{\theta_i} \right|_{\text{Infinite cylinder}} = 1.109 \exp[-(1.307 \text{ rad})^2 \times 0.47] = 0.550$$

The surface temperature can be evaluated using Equation 5.49b

$$\frac{\theta^*}{\theta_o^*} = \frac{\theta}{\theta_o} = J_0(\zeta_1 r^*)$$

with $r^* = 1$ and the value of the Bessel function determined from Table B.4,

$$\frac{\theta^*(1, Fo)}{\theta_o^*} = \frac{\theta(L, t)}{\theta_o} = J_0(1.307 \text{ rad} \times 1) = 0.616$$

The one-term approximations are in good agreement with results from the Heisler charts.

5.9 FINITE-DIFFERENCE METHODS

Analytical solutions to transient problems are restricted to simple geometries and boundary conditions, such as those considered in the preceding sections. Extensive coverage of these and other solutions is treated in the literature [1-4]. However, in many cases the geometry and/or boundary conditions preclude the use of analytical techniques, and recourse must be made to

finite-difference methods. Such methods, introduced in Section 4.4 for steady-state conditions, are readily extended to transient problems. In this section we consider *explicit* and *implicit* forms of finite-difference solutions to transient conduction problems. More detailed treatments, as well as related algorithms, may be found in the literature [8–10].

5.9.1 Discretization of the Heat Equation: The Explicit Method

Once again consider the two-dimensional system of Figure 4.5. Under transient conditions with constant properties and no internal generation, the appropriate form of the heat equation, Equation 2.15, is

$$\frac{1}{\alpha} \frac{\partial T}{\partial t} = \frac{\partial^2 T}{\partial x^2} + \frac{\partial^2 T}{\partial y^2} \quad (5.67)$$

To obtain the finite-difference form of this equation, we may use the *central-difference* approximations to the spatial derivatives prescribed by Equations 4.31 and 4.32. Once again the m and n subscripts may be used to designate the x and y locations of *discrete nodal points*. However, in addition to being discretized in space, the problem must be discretized in time. The integer p is introduced for this purpose, where

$$t = p \Delta t \quad (5.68)$$

and the finite-difference approximation to the time derivative in Equation 5.67 is expressed as

$$\left. \frac{\partial T}{\partial t} \right|_{m,n} \approx \frac{T_{m,n}^{p+1} - T_{m,n}^p}{\Delta t} \quad (5.69)$$

The superscript p is used to denote the time dependence of T , and the time derivative is expressed in terms of the difference in temperatures associated with the *new* ($p + 1$) and *previous* (p) times. Hence calculations must be performed at successive times separated by the interval Δt , and just as a finite-difference solution restricts temperature determination to discrete points in space, it also restricts it to discrete points in time.

If Equation 5.69 is substituted into Equation 5.67, the nature of the finite-difference solution will depend on the specific time at which temperatures are evaluated in the finite-difference approximations to the spatial derivatives. In the *explicit method* of solution, these temperatures are evaluated at the *previous* (p) time. Hence Equation 5.69 is considered to be a *forward-difference* approximation to the time derivative. Evaluating terms on the right-hand side of Equations 4.31 and 4.32 at p and substituting into Equation 5.67, the explicit form of the finite-difference equation for the

interior node m, n is

$$\frac{1}{\alpha} \frac{T_{m,n}^{p+1} - T_{m,n}^p}{\Delta t} = \frac{T_{m+1,n}^p + T_{m-1,n}^p - 2T_{m,n}^p}{(\Delta x)^2} + \frac{T_{m,n+1}^p + T_{m,n-1}^p - 2T_{m,n}^p}{(\Delta y)^2} \quad (5.70)$$

Solving for the nodal temperature at the new $(p + 1)$ time and assuming that $\Delta x = \Delta y$, it follows that

$$T_{m,n}^{p+1} = Fo(T_{m+1,n}^p + T_{m-1,n}^p + T_{m,n+1}^p + T_{m,n-1}^p) + (1 - 4Fo)T_{m,n}^p \quad (5.71)$$

where Fo is a finite-difference form of the Fourier number

$$Fo = \frac{\alpha \Delta t}{(\Delta x)^2} \quad (5.72)$$

If the system is one-dimensional in x , the explicit form of the finite-difference equation for an interior node m reduces to

$$T_m^{p+1} = Fo(T_{m+1}^p + T_{m-1}^p) + (1 - 2Fo)T_m^p \quad (5.73)$$

Equations 5.71 and 5.73 are *explicit* because *unknown* nodal temperatures for the new time are determined exclusively by *known* nodal temperatures at the previous time. Hence calculation of the unknown temperatures is straightforward. Since the temperature of each interior node is known at $t = 0$ ($p = 0$) from prescribed initial conditions, the calculations begin at $t = \Delta t$ ($p = 1$), where Equation 5.71 or 5.73 is applied to each interior node to determine its temperature. With temperatures known for $t = \Delta t$, the appropriate finite-difference equation is then applied at each node to determine its temperature at $t = 2\Delta t$ ($p = 2$). In this way, the transient temperature distribution is obtained by *marching out in time*, using intervals of Δt .

The accuracy of the finite-difference solution may be improved by decreasing the values of Δx and Δt . Of course, the number of interior nodal points that must be considered increases with decreasing Δx , and the number of time intervals required to carry the solution to a prescribed final time increases with decreasing Δt . Hence, the computation time increases with decreasing Δx and Δt . The choice of Δx is typically based on a compromise between accuracy and computational requirements. Once this selection has been made, however, the value of Δt may not be chosen independently. It is, instead, determined by *stability* requirements.

An undesirable feature of the explicit method is that it is not unconditionally *stable*. In a transient problem, the solution for the nodal temperatures should continuously approach final (steady-state) values with increasing time. However, with the explicit method, this solution may be characterized by numerically induced oscillations, which are physically impossible. The oscillations may become *unstable*, causing the solution to diverge from the actual steady-state conditions. To prevent such erroneous results, the prescribed value of Δt must be maintained below a certain limit, which depends on Δx and other parameters of the system. This dependence is termed a *stability criterion*, which may be obtained mathematically [8] or demonstrated from a thermodynamic argument (see Problem 5.69). For the problems of interest in this text, *the criterion is determined by requiring that the coefficient associated with the node of interest at the previous time is greater than or equal to zero*. In general, this is done by collecting all terms involving $T_{m,n}^p$ to obtain the form of the coefficient. This result is then used to obtain a limiting relation involving Fo , from which the maximum allowable value of Δt may be determined. For example, with Equations 5.71 and 5.73 already expressed in the desired form, it follows that the stability criterion for a one-dimensional interior node is $(1 - 2Fo) \geq 0$, or

$$Fo \leq \frac{1}{2} \quad (5.74)$$

and for a two-dimensional node, it is $(1 - 4Fo) \geq 0$, or

$$Fo \leq \frac{1}{4} \quad (5.75)$$

For prescribed values of Δx and α , these criteria may be used to determine upper limits to the value of Δt .

Equations 5.71 and 5.73 may also be derived by applying the energy balance method of Section 4.4.3 to a control volume about the interior node. Accounting for changes in thermal energy storage, a general form of the energy balance equation may be expressed as

$$\dot{E}_{in} + \dot{E}_g = \dot{E}_{st} \quad (5.76)$$

In the interest of adopting a consistent methodology, it is again assumed that all heat flow is *into* the node.

To illustrate application of Equation 5.76, consider the surface node of the one-dimensional system shown in Figure 5.22. To more accurately determine thermal conditions near the surface, this node has been assigned a thickness which is one-half that of the interior nodes. Assuming convection transfer from an adjoining fluid and no generation, it follows from Equation 5.76 that

$$hA(T_\infty - T_0^p) + \frac{kA}{\Delta x}(T_1^p - T_0^p) = \rho cA \frac{\Delta x}{2} \frac{T_0^{p+1} - T_0^p}{\Delta t}$$

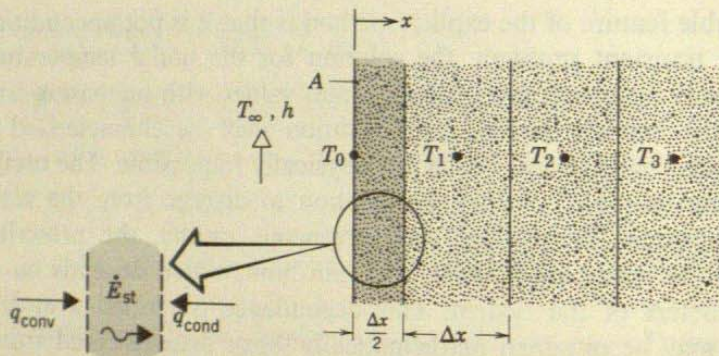

Figure 5.22 Surface node with convection and one-dimensional transient conduction.

or, solving for the surface temperature at $t + \Delta t$,

$$T_0^{p+1} = \frac{2h \Delta t}{\rho c \Delta x} (T_\infty - T_0^p) + \frac{2\alpha \Delta t}{\Delta x^2} (T_1^p - T_0^p) + T_0^p$$

Recognizing that $(2h \Delta t / \rho c \Delta x) = 2(h \Delta x / k)(\alpha \Delta t / \Delta x^2) = 2BiFo$ and grouping terms involving T_0^p , it follows that

$$T_0^{p+1} = 2Fo(T_1^p + BiT_\infty) + (1 - 2Fo - 2BiFo)T_0^p \quad (5.77)$$

The finite-difference form of the Biot number is

$$Bi = \frac{h \Delta x}{k} \quad (5.78)$$

Recalling the procedure for determining the stability criterion, we require that the coefficient for T_0^p be greater than or equal to zero. Hence

$$1 - 2Fo - 2BiFo \geq 0$$

or

$$Fo(1 + Bi) \leq \frac{1}{2} \quad (5.79)$$

Since the complete finite-difference solution requires the use of Equation 5.73 for the interior nodes, as well as Equation 5.77 for the surface node, Equation 5.79 must be contrasted with Equation 5.74 to determine which requirement is the more stringent. Since $Bi \geq 0$, it is apparent that the limiting value of Fo for Equation 5.79 is less than that for Equation 5.74. To ensure stability for all nodes, Equation 5.79 should therefore be used to select the maximum allowable value of Fo , and hence Δt , to be used in the calculations.

Forms of the explicit finite-difference equation for several common geometries are presented in Table 5.2. Each equation may be derived by applying the energy balance method to a control volume about the corresponding node. To develop confidence in your ability to apply this method, you should attempt to verify at least one of these equations.

Table 5.2 Summary of transient, two-dimensional finite-difference equations ($\Delta x = \Delta y$)

CONFIGURATION	FINITE-DIFFERENCE EQUATION	STABILITY CRITERION	IMPLICIT METHOD
$m, n + 1$ $T_{m,n}^{p+1} = Fo(T_{m,n}^p + \dots)$	EXPLICIT METHOD		

Table 5.2 Summary of transient, two-dimensional finite-difference equations ($\Delta x = \Delta y$)

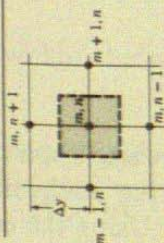
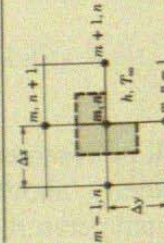
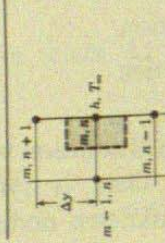
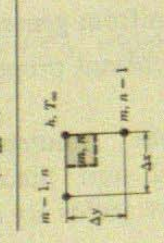
CONFIGURATION	EXPLICIT METHOD		IMPLICIT METHOD
	FINITE-DIFFERENCE EQUATION	STABILITY CRITERION	
	$T_{m,n}^{p+1} = Fo(T_{m+1,n}^p + T_{m-1,n}^p + T_{m,n+1}^p + T_{m,n-1}^p) + (1 - 4Fo)T_{m,n}^p$ <p>(5.71)</p> <p>1. Interior node</p>	$Fo \leq \frac{1}{4}$ <p>(5.75)</p>	$(1 + 4Fo)T_{m,n}^{p+1} - Fo(T_{m+1,n}^{p+1} + T_{m-1,n}^{p+1} + T_{m,n+1}^{p+1} + T_{m,n-1}^{p+1}) = T_{m,n}^p$ <p>(5.87)</p>
	$T_{m,n}^{p+1} = \frac{2}{3}Fo(T_{m+1,n}^p + 2T_{m,n-1}^p + 2T_{m,n+1}^p) + 2T_{m,n-1}^p + T_{m,n-1}^p + 2BiT_\infty + (1 - 4Fo - \frac{4}{3}BiFo)T_{m,n}^p$ <p>(5.80)</p> <p>2. Node at interior corner with convection</p>	$Fo(3 + Bi) \leq \frac{3}{4}$ <p>(5.81)</p>	$(1 + 4Fo(1 + \frac{1}{3}Bi))T_{m,n}^{p+1} - \frac{2}{3}Fo(T_{m+1,n}^{p+1} + 2T_{m,n-1}^{p+1} + 2T_{m,n+1}^{p+1} + T_{m,n-1}^{p+1}) = T_{m,n}^p + \frac{4}{3}BiFoT_\infty$ <p>(5.90)</p>
	$T_{m,n}^{p+1} = Fo(2T_{m-1,n}^p + T_{m,n+1}^p + T_{m,n-1}^p + 2BiT_\infty) + (1 - 4Fo - 2BiFo)T_{m,n}^p$ <p>(5.82)</p> <p>3. Node at plane surface with convection^a</p>	$Fo(2 + Bi) \leq \frac{1}{2}$ <p>(5.83)</p>	$(1 + 2Fo(2 + Bi))T_{m,n}^{p+1} - Fo(2T_{m-1,n}^{p+1} + T_{m,n+1}^{p+1} + T_{m,n-1}^{p+1} + T_{m,n-1}^{p+1}) = T_{m,n}^p + 2BiFoT_\infty$ <p>(5.91)</p>
	$T_{m,n}^{p+1} = 2Fo(T_{m-1,n}^p + T_{m,n-1}^p + 2BiT_\infty) + (1 - 4Fo - 4BiFo)T_{m,n}^p$ <p>(5.84)</p> <p>4. Node at exterior corner with convection</p>	$Fo(1 + Bi) \leq \frac{1}{4}$ <p>(5.85)</p>	$(1 + 4Fo(1 + Bi))T_{m,n}^{p+1} - 2Fo(T_{m-1,n}^{p+1} + T_{m,n-1}^{p+1}) = T_{m,n}^p + 4BiFoT_\infty$ <p>(5.92)</p>

^aTo obtain the finite-difference equation and/or stability criterion for an adiabatic surface (or surface of symmetry), simply set Bi equal to zero.

LIBRARY U. OF I. URBANA-CHAMPAIGN

EXAMPLE 5.6

A fuel element of a nuclear reactor is in the shape of a plane wall of thickness $2L = 20$ mm and is convectively cooled at both surfaces, with $h = 1100$ $\text{W/m}^2 \cdot \text{K}$ and $T_\infty = 250^\circ\text{C}$. At normal operating power, heat is generated uniformly within the element at a volumetric rate of $\dot{q}_1 = 10^7$ W/m^3 . A departure from the steady-state conditions associated with normal operation will occur if there is a change in the generation rate. Consider a sudden change to $\dot{q}_2 = 2 \times 10^7$ W/m^3 , and use the explicit finite-difference method to determine the fuel element temperature distribution after 1.5 s. The fuel element thermal properties are $k = 30$ $\text{W/m} \cdot \text{K}$ and $\alpha = 5 \times 10^{-6}$ m^2/s .

SOLUTION

Known: Conditions associated with heat generation in a rectangular fuel element with surface cooling.

Find: Temperature distribution 1.5 s after a change in operating power.

Schematic:

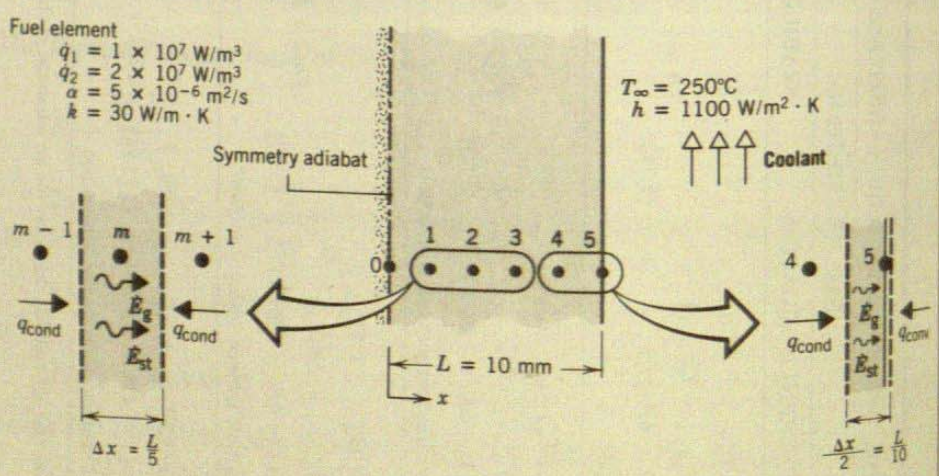

Assumptions:

1. One-dimensional conduction in x .
2. Uniform generation.
3. Constant properties.

Analysis: A numerical solution will be obtained using a space increment of $\Delta x = 2$ mm. Since there is symmetry about the midplane, the nodal network yields six unknown nodal temperatures. Using the energy balance

method, Equati
for any interior

$$kA \frac{T_m^p - T_{m-1}^p}{\Delta x} - \dot{q}_m V_m + hA(T_\infty - T_m^p) = \rho V_m c_p \frac{T_m^{p+1} - T_m^p}{\Delta t}$$

Solving for T_m^{p+1}

$$T_m^{p+1} = Fo(T_{m-1}^p + T_{m+1}^p) + (1 - 2Fo)T_m^p + \frac{Fo \dot{q}_m \Delta x^2}{k} + \frac{Fo h \Delta x^2}{k} (T_\infty - T_m^p)$$

This equation
nodes 1, 2, 3,
about node 5,

$$hA(T_\infty - T_5^p) = \rho V_5 c_p \frac{T_5^{p+1} - T_5^p}{\Delta t}$$

or

$$T_5^{p+1} = 2Fo(T_4^p + T_\infty) + (1 - 2Fo)T_5^p + \frac{Fo \dot{q}_5 \Delta x^2}{k}$$

Since the
2, we select Fo

$$Fo(1 + Bi) = \frac{c_p \Delta t}{\alpha}$$

Hence, with

$$Bi = \frac{h \Delta x}{k}$$

it follows that

$$Fo \leq 0.46$$

or

$$\Delta t = \frac{Fo(1 + Bi) \alpha}{c_p}$$

To be well w
sponds to

$$Fo = \frac{5 \times 10^{-6} \times 0.46}{1000 \times 2000} = 1.15 \times 10^{-6}$$

method, Equation 5.76, an explicit finite-difference equation may be derived for any interior node m .

$$kA \frac{T_{m-1}^p - T_m^p}{\Delta x} + kA \frac{T_{m+1}^p - T_m^p}{\Delta x} + \dot{q}A \Delta x = \rho A \Delta x c \frac{T_m^{p+1} - T_m^p}{\Delta t}$$

Solving for T_m^{p+1} and rearranging,

$$T_m^{p+1} = Fo \left[T_{m-1}^p + T_{m+1}^p + \frac{\dot{q}(\Delta x)^2}{k} \right] + (1 - 2Fo)T_m^p \quad (1)$$

This equation may be used for node 0, with $T_{m-1}^p = T_{m+1}^p$, as well as for nodes 1, 2, 3, and 4. Applying energy conservation to a control volume about node 5,

$$hA(T_\infty - T_5^p) + kA \frac{T_4^p - T_5^p}{\Delta x} + \dot{q}A \frac{\Delta x}{2} = \rho A \frac{\Delta x}{2} c \frac{T_5^{p+1} - T_5^p}{\Delta t}$$

or

$$T_5^{p+1} = 2Fo \left[T_4^p + BiT_\infty + \frac{\dot{q}(\Delta x)^2}{2k} \right] + (1 - 2Fo - 2BiFo)T_5^p \quad (2)$$

Since the most restrictive stability criterion is associated with Equation 2, we select Fo from the requirement that

$$Fo(1 + Bi) \leq \frac{1}{2}$$

Hence, with

$$Bi = \frac{h \Delta x}{k} = \frac{1100 \text{ W/m}^2 \cdot \text{K} (0.002 \text{ m})}{30 \text{ W/m} \cdot \text{K}} = 0.0733$$

it follows that

$$Fo \leq 0.466$$

or

$$\Delta t = \frac{Fo(\Delta x)^2}{\alpha} \leq \frac{0.466(2 \times 10^{-3} \text{ m})^2}{5 \times 10^{-6} \text{ m}^2/\text{s}} \leq 0.373 \text{ s}$$

To be well within the stability limit, we select $\Delta t = 0.3 \text{ s}$, which corresponds to

$$Fo = \frac{5 \times 10^{-6} \text{ m}^2/\text{s}(0.3 \text{ s})}{(2 \times 10^{-3} \text{ m})^2} = 0.375$$

... wall of thickness
s, with $h = 1100$
heat is generated
 $= 10^7 \text{ W/m}^3$. A
normal operation
a sudden change
ence method to
1.5 s. The fuel
 $\times 10^{-6} \text{ m}^2/\text{s}$.

rectangular fuel

ating power.

$n^2 \cdot K$

oolant

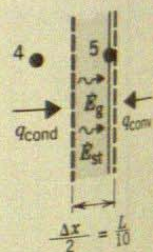

increment of
e, the nodal
energy balance

LIBRARY U. OF I. URBANA-CHAMPAIGN

Substituting numerical values, including $\dot{q} = \dot{q}_2 = 2 \times 10^7 \text{ W/m}^3$, the nodal equations become

$$T_0^{p+1} = 0.375(2T_1^p + 2.67) + 0.250T_0^p$$

$$T_1^{p+1} = 0.375(T_0^p + T_2^p + 2.67) + 0.250T_1^p$$

$$T_2^{p+1} = 0.375(T_1^p + T_3^p + 2.67) + 0.250T_2^p$$

$$T_3^{p+1} = 0.375(T_2^p + T_4^p + 2.67) + 0.250T_3^p$$

$$T_4^{p+1} = 0.375(T_3^p + T_5^p + 2.67) + 0.250T_4^p$$

$$T_5^{p+1} = 0.750(T_4^p + 19.67) + 0.195T_5^p$$

To begin the marching solution, the initial temperature distribution must be known. This distribution is given by Equation 3.42, with $\dot{q} = \dot{q}_1$. Obtaining $T_s = T_5$ from Equation 3.46,

$$T_5 = T_\infty + \frac{\dot{q}L}{h} = 250^\circ\text{C} + \frac{10^7 \text{ W/m}^3 \times 0.01 \text{ m}}{1100 \text{ W/m}^2 \cdot \text{K}} = 340.91^\circ\text{C}$$

it follows that

$$T(x) = 16.67 \left(1 - \frac{x^2}{L^2} \right) + 340.91^\circ\text{C}$$

Computed temperatures for the nodal points of interest are shown in the first row of the accompanying table.

Using the finite-difference equations, the nodal temperatures may be sequentially calculated with a time increment of 0.3 s until the desired final time is reached. The results are illustrated in rows 2 through 6 of the table and may be contrasted with the new steady-state condition (row 7), which was obtained by using Equations 3.42 and 3.46 with $\dot{q} = \dot{q}_2$.

Tabulated nodal temperatures

p	t (s)	T_0	T_1	T_2	T_3	T_4	T_5
0	0	357.58	356.91	354.91	351.58	346.91	340.91
1	0.3	358.08	357.41	355.41	352.08	347.41	341.41
2	0.6	358.58	357.91	355.91	352.58	347.91	341.88
3	0.9	359.08	358.41	356.41	353.08	348.41	342.35
4	1.2	359.58	358.91	356.91	353.58	348.89	342.82
5	1.5	360.08	359.41	357.41	354.07	349.37	343.27
∞	∞	465.15	463.82	459.82	453.15	443.82	431.82

Comments: It is evident that at 1.5 s, the wall is in the early stages of the transient process and that many additional calculations would have to be made to reach steady-state conditions with the finite-difference solution. The computation time could be slightly reduced by using the maximum allowable time increment ($\Delta t = 0.373$ s), but with some loss of accuracy. In the interest of maximizing accuracy, the time interval should be reduced until the computed results become independent of further reductions in Δt .

5.9.2 Discretization of the Heat Equation: The Implicit Method

In the *explicit* finite-difference scheme, the temperature of any node at $t + \Delta t$ may be calculated from knowledge of temperatures at the same and neighboring nodes for the *preceding time* t . Hence, determination of a nodal temperature at some time is *independent* of temperatures at other nodes for the *same time*. Although the method offers computational convenience, it suffers from limitations on the selection of Δt . For a given space increment, the time interval must be compatible with stability requirements. Frequently, this dictates the use of extremely small values of Δt , and a very large number of time intervals may be necessary to obtain a solution.

A reduction in the amount of computation time may often be realized by employing an *implicit*, rather than explicit, finite-difference scheme. The implicit form of a finite-difference equation may be derived by using Equation 5.69 to approximate the time derivative, while evaluating all other temperatures at the *new* ($p + 1$) time, instead of the previous (p) time. Equation 5.69 is then considered to provide a *backward-difference* approximation to the time derivative. In contrast to Equation 5.70, the implicit form of the finite-difference equation for the interior node of a two-dimensional system is then

$$\frac{1}{\alpha} \frac{T_{m,n}^{p+1} - T_{m,n}^p}{\Delta t} = \frac{T_{m+1,n}^{p+1} + T_{m-1,n}^{p+1} - 2T_{m,n}^{p+1}}{(\Delta x)^2} + \frac{T_{m,n+1}^{p+1} + T_{m,n-1}^{p+1} - 2T_{m,n}^{p+1}}{(\Delta y)^2} \quad (5.86)$$

Rearranging and assuming $\Delta x = \Delta y$, it follows that

$$(1 + 4Fo)T_{m,n}^{p+1} - Fo(T_{m+1,n}^{p+1} + T_{m-1,n}^{p+1} + T_{m,n+1}^{p+1} + T_{m,n-1}^{p+1}) = T_{m,n}^p \quad (5.87)$$

From Equation 5.87 it is evident that the *new* temperature of the m, n node depends on the *new* temperatures of its adjoining nodes, which are, in

LIBRARY U. OF I. URBANA-CHAMPAIGN

general, unknown. Hence, to determine the unknown nodal temperatures at $t + \Delta t$, the corresponding nodal equations must be *solved simultaneously*. Such a solution may be effected by using Gauss-Seidel iteration or matrix inversion, as discussed in Section 4.5. The *marching solution* would then involve simultaneously solving the nodal equations at each time $t = \Delta t, 2\Delta t, \dots$, until the desired final time was reached.

Although computations involving the implicit method are more complicated than those of the explicit method, the implicit formulation has the important advantage of being *unconditionally stable*. That is, the solution remains stable for all space and time intervals, in which case there are no restrictions on Δx and Δt . Since larger values of Δt may therefore be used with an implicit method, computation times may often be reduced, with little loss of accuracy. Nevertheless, to maximize accuracy, Δt should be sufficiently small to ensure that the results are independent of further reductions in its value.

The implicit form of a finite-difference equation may also be derived from the energy balance method. For the surface node of Figure 5.22, it is readily shown that

$$(1 + 2Fo + 2FoBi)T_0^{p+1} - 2FoT_1^{p+1} = 2FoBiT_\infty + T_0^p \quad (5.88)$$

For any interior node of Figure 5.22, it may also be shown that

$$(1 + 2Fo)T_m^{p+1} - Fo(T_{m-1}^{p+1} + T_{m+1}^{p+1}) = T_m^p \quad (5.89)$$

Forms of the implicit finite-difference equation for other common geometries are presented in Table 5.2. Each equation may be derived by applying the energy balance method.

EXAMPLE 5.7

A thick slab of copper initially at a uniform temperature of 20°C is suddenly exposed to radiation at one surface such that the net heat flux is maintained at a constant value of $3 \times 10^5 \text{ W/m}^2$. Using the explicit and implicit finite-difference techniques with a space increment of $\Delta x = 75 \text{ mm}$, determine the temperature at the irradiated surface and at an interior point that is 150 mm from the surface after 2 min have elapsed. Compare the results with those obtained from an appropriate analytical solution.

SOLUTION

Known: Thick slab of copper, initially at a uniform temperature, is subjected to a constant net heat flux at one surface.

Find:

1. Using the explicit method, determine the surface and interior temperatures at $t = 2 \text{ min}$.
2. Repeat the calculation using the implicit method.
3. Determine the error in the explicit method results.

Schematic:

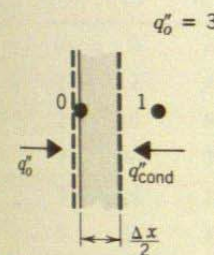

Assumptions:

1. One-dimensional conduction.
2. Thick slab approximation.
3. Constant properties.

Properties: Table A.1, $\alpha = 11.7 \times 10^{-6} \text{ m}^2/\text{s}$.

Analysis:

1. An explicit finite-difference method may be obtained by applying the energy balance method about the node at $x = 0$.

$$q_o''A + \dots$$

or

$$T_0^{p+1} = \dots$$

The finite-difference equation 5.73. B

Find:

1. Using the explicit finite-difference method, determine temperatures at the surface and 150 mm from the surface after an elapsed time of 2 min.
2. Repeat the calculations using the implicit finite-difference method.
3. Determine the same temperatures analytically.

Schematic:

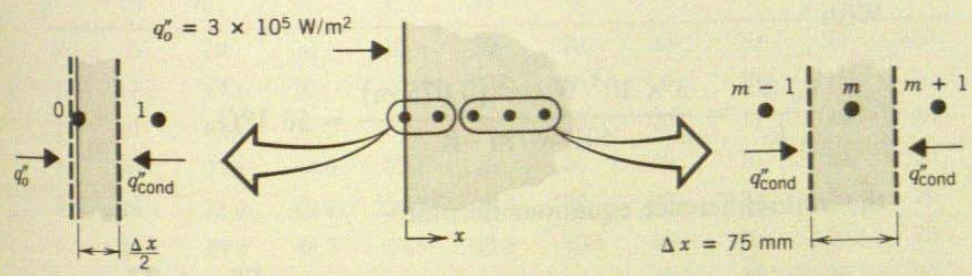

Assumptions:

1. One-dimensional conduction in x .
2. Thick slab may be approximated as a semi-infinite medium with constant surface heat flux.
3. Constant properties.

Properties: Table A.1, copper (300 K): $k = 401 \text{ W/m} \cdot \text{K}$, $\alpha = 117 \times 10^{-6} \text{ m}^2/\text{s}$.

Analysis:

1. An explicit form of the finite-difference equation for the surface node may be obtained by applying an energy balance to a control volume about the node.

$$q''_o A + kA \frac{T_1^p - T_0^p}{\Delta x} = \rho A \frac{\Delta x}{2} c \frac{T_0^{p+1} - T_0^p}{\Delta t}$$

or

$$T_0^{p+1} = 2Fo \left(\frac{q''_o \Delta x}{k} + T_1^p \right) + (1 - 2Fo) T_0^p$$

The finite-difference equation for any interior node is given by Equation 5.73. Both the surface and interior nodes are governed by the

LIBRARY U. OF I. URBANA-CHAMPAIGN

stability criterion

$$Fo \leq \frac{1}{2}$$

Noting that the finite-difference equations are simplified by choosing the maximum allowable value of Fo , we select $Fo = \frac{1}{2}$. Hence

$$\Delta t = Fo \frac{(\Delta x)^2}{\alpha} = \frac{1}{2} \frac{(0.075 \text{ m})^2}{117 \times 10^{-6} \text{ m}^2/\text{s}} = 24 \text{ s}$$

With

$$\frac{q_o'' \Delta x}{k} = \frac{3 \times 10^5 \text{ W/m}^2 (0.075 \text{ m})}{401 \text{ W/m} \cdot \text{K}} = 56.1^\circ\text{C}$$

the finite-difference equations become

$$T_0^{p+1} = 56.1^\circ\text{C} + T_1^p \quad \text{and} \quad T_m^{p+1} = \frac{T_{m+1}^p + T_{m-1}^p}{2}$$

for the surface and interior nodes, respectively. Performing the calculations, the results are tabulated as follows.

Explicit finite-difference solution for $Fo = \frac{1}{2}$

p	t (s)	T_0	T_1	T_2	T_3	T_4
0	0	20	20	20	20	20
1	24	76.1	20	20	20	20
2	48	76.1	48.1	20	20	20
3	72	104.2	48.1	34.1	20	20
4	96	104.2	69.1	34.1	27.1	20
5	120	125.3	69.1	48.1	27.1	20

After 2 min, the surface temperature and the desired interior temperature are $T_0 = 125.3^\circ\text{C}$ and $T_2 = 48.1^\circ\text{C}$.

Note that calculation of identical temperatures at successive times for the same node is an idiosyncrasy of using the maximum allowable value of Fo with the explicit finite-difference technique. The actual physical condition is, of course, one in which the temperature changes continuously with time. The idiosyncrasy is eliminated and the accuracy of the calculations is improved by reducing the value of Fo .

To determine the extent to which the accuracy may be improved by reducing Fo , let us redo the calculations for $Fo = \frac{1}{4}$ ($\Delta t = 12 \text{ s}$). The

finite-differ

$$T_0^{p+1}$$

$$T_m^{p+1}$$

and the re

Explicit fini

p	t (s)
0	0
1	12
2	24
3	36
4	48
5	60
6	72
7	84
8	96
9	108
10	120

After 2 m

44.4°C. C

is clear t

recurring

tration (t

ment in a

exact solu

2. Performin

node, the

$$q_o'' +$$

or,

$$(1 +$$

Arbitrari

$$2T_0^p$$

finite-difference equations are then of the form

$$T_0^{p+1} = \frac{1}{2}(56.1^\circ\text{C} + T_1^p) + \frac{1}{2}T_0^p$$

$$T_m^{p+1} = \frac{1}{4}(T_{m+1}^p + T_{m-1}^p) + \frac{1}{2}T_m^p$$

and the results of the calculations are tabulated as follows.

Explicit finite-difference solution for $Fo = 1/4$

$ p $	$ t \text{ (s)} $	$ T_0 $	$ T_1 $	$ T_2 $	$ T_3 $	$ T_4 $	$ T_5 $	$ T_6 $	$ T_7 $	$ T_8 $
0	0	20	20	20	20	20	20	20	20	20
1	12	48.1	20	20	20	20	20	20	20	20
2	24	62.1	27.0	20	20	20	20	20	20	20
3	36	72.6	34.0	21.8	20	20	20	20	20	20
4	48	81.4	40.6	24.4	20.4	20	20	20	20	20
5	60	89.0	46.7	27.5	21.3	20.1	20	20	20	20
6	72	95.9	52.5	30.7	22.6	20.4	20.0	20	20	20
7	84	102.3	57.9	34.1	24.1	20.8	20.1	20.0	20	20
8	96	108.1	63.1	37.6	25.8	21.5	20.3	20.0	20.0	20
9	108	113.7	68.0	41.0	27.6	22.2	20.5	20.1	20.0	20.0
10	120	118.9	72.6	44.4	29.6	23.2	20.8	20.2	20.0	20.0

After 2 min, the desired temperatures are $T_0 = 118.9^\circ\text{C}$ and $T_2 = 44.4^\circ\text{C}$. Comparing the above results with those obtained for $Fo = \frac{1}{2}$, it is clear that by reducing Fo we have eliminated the problem of recurring temperatures. We have also predicted greater thermal penetration (to node 6 instead of node 3). An assessment of the improvement in accuracy must await a comparison with results based on an exact solution.

- Performing an energy balance on a control volume about the surface node, the implicit form of the finite-difference equation is

$$q_o'' + k \frac{T_1^{p+1} - T_0^{p+1}}{\Delta x} = \rho \frac{\Delta x}{2} c \frac{T_0^{p+1} - T_0^p}{\Delta t}$$

or,

$$(1 + 2Fo)T_0^{p+1} - 2FoT_1^{p+1} = \frac{2\alpha q_o'' \Delta t}{k \Delta x} + T_0^p$$

Arbitrarily choosing $Fo = \frac{1}{2} (\Delta t = 24 \text{ s})$, it follows that

$$2T_0^{p+1} - T_1^{p+1} = 56.1 + T_0^p$$

LIBRARY U. OF I. URBANA-CHAMPAIGN

From Equation 5.89, the finite-difference equation for any interior node is then of the form

$$-T_{m-1}^{p+1} + 4T_m^{p+1} - T_{m+1}^{p+1} = 2T_m^p$$

Since we are dealing with a semi-infinite solid, the number of nodes is, in principle, infinite. In practice, however, the number may be limited to the nodes that are affected by the change in the boundary condition for the time period of interest. From the results of the explicit method, it is evident that we are safe in choosing nine nodes corresponding to T_0, T_1, \dots, T_8 . We are thereby assuming that, at $t = 120$ s, there has been no change in T_8 .

We now have a set of nine equations that must be solved simultaneously for each time increment. Using the matrix inversion method, we express the equations in the form $[A][T] = [C]$, where

$$[A] = \begin{bmatrix} 2 & -1 & 0 & 0 & 0 & 0 & 0 & 0 & 0 \\ -1 & 4 & -1 & 0 & 0 & 0 & 0 & 0 & 0 \\ 0 & -1 & 4 & -1 & 0 & 0 & 0 & 0 & 0 \\ 0 & 0 & -1 & 4 & -1 & 0 & 0 & 0 & 0 \\ 0 & 0 & 0 & -1 & 4 & -1 & 0 & 0 & 0 \\ 0 & 0 & 0 & 0 & -1 & 4 & -1 & 0 & 0 \\ 0 & 0 & 0 & 0 & 0 & -1 & 4 & -1 & 0 \\ 0 & 0 & 0 & 0 & 0 & 0 & -1 & 4 & -1 \\ 0 & 0 & 0 & 0 & 0 & 0 & 0 & -1 & 4 \end{bmatrix}$$

$$[C] = \begin{bmatrix} 56.1 + T_0^p \\ 2T_1^p \\ 2T_2^p \\ 2T_3^p \\ 2T_4^p \\ 2T_5^p \\ 2T_6^p \\ 2T_7^p \\ 2T_8^p + T_9^{p+1} \end{bmatrix}$$

Note that numerical values for the components of $[C]$ are determined from previous values of the nodal temperatures. Note also how the finite-difference equation for node 8 appears in matrices $[A]$ and $[C]$.

A table of nodal temperatures may be compiled, beginning with the first row ($p = 0$) corresponding to the prescribed initial condition. To obtain nodal temperatures for subsequent times, the inverse of the

coeffic
then mu
obtain
ing $[A]$

$[C]$

the sec
repeate
The de

Implicit fin

p	t (s)
0	0
1	24
2	48
3	72
4	96
5	120

3. Appro
analyti
to any

T

At the

$T(0, 120 \text{ s})$

or

T

coefficient matrix $[A]^{-1}$ must first be found. At each time $p + 1$, it is then multiplied by the column vector $[C]$, which is evaluated at p , to obtain the temperatures $T_0^{p+1}, T_1^{p+1}, \dots, T_8^{p+1}$. For example, multiplying $[A]^{-1}$ by the column vector corresponding to $p = 0$,

$$[C]_{p=0} = \begin{bmatrix} 76.1 \\ 40 \\ 40 \\ 40 \\ 40 \\ 40 \\ 40 \\ 40 \\ 60 \end{bmatrix}$$

the second row of the table is obtained. Updating $[C]$, the process is repeated four more times to determine the nodal temperatures at 120 s. The desired temperatures are $T_0 = 114.7^\circ\text{C}$ and $T_2 = 44.2^\circ\text{C}$.

Implicit finite-difference solution for $Fo = \frac{1}{2}$

p	t (s)	T_0	T_1	T_2	T_3	T_4	T_5	T_6	T_7	T_8
0	0	20.0	20.0	20.0	20.0	20.0	20.0	20.0	20.0	20.0
1	24	52.4	28.7	22.3	20.6	20.2	20.0	20.0	20.0	20.0
2	48	74.0	39.5	26.6	22.1	20.7	20.2	20.1	20.0	20.0
3	72	90.2	50.3	32.0	24.4	21.6	20.6	20.2	20.1	20.0
4	96	103.4	60.5	38.0	27.4	22.9	21.1	20.4	20.2	20.1
5	120	114.7	70.0	44.2	30.9	24.7	21.9	20.8	20.3	20.1

- Approximating the slab as a semi-infinite medium, the appropriate analytical expression is given by Equation 5.58, which may be applied to any point in the slab.

$$T(x, t) - T_i = \frac{2q_o''(at/\pi)^{1/2}}{k} \exp\left(-\frac{x^2}{4at}\right) - \frac{q_o''x}{k} \operatorname{erfc}\left(\frac{x}{2\sqrt{at}}\right)$$

At the surface, this expression yields

$$T(0, 120 \text{ s}) - 20^\circ\text{C} = \frac{2 \times 3 \times 10^5 \text{ W/m}^2}{401 \text{ W/m} \cdot \text{K}} (117 \times 10^{-6} \text{ m}^2/\text{s} \times 120 \text{ s}/\pi)^{1/2}$$

or

$$T(0, 120 \text{ s}) = 120.0^\circ\text{C}$$

LIBRARY U. OF I. URBANA-CHAMPAIGN

At the interior point ($x = 0.15$ m)

$$T(0.15 \text{ m}, 120 \text{ s}) - 20^\circ\text{C} = \frac{2 \times 3 \times 10^5 \text{ W/m}^2}{401 \text{ W/m} \cdot \text{K}} \times (117 \times 10^{-6} \text{ m}^2/\text{s} \times 120 \text{ s}/\pi)^{1/2} \times \exp\left[-\frac{(0.15 \text{ m})^2}{4 \times 117 \times 10^{-6} \text{ m}^2/\text{s} \times 120 \text{ s}}\right] - \frac{3 \times 10^5 \text{ W/m}^2 \times 0.15 \text{ m}}{401 \text{ W/m} \cdot \text{K}} \times \left[1 - \operatorname{erf}\left(\frac{0.15 \text{ m}}{2\sqrt{117 \times 10^{-6} \text{ m}^2/\text{s} \times 120 \text{ s}}}\right)\right] = 45.4^\circ\text{C}$$

Comments:

1. Comparing the exact results with those obtained from the three approximate solutions, it is clear that the explicit method with $Fo = 1/4$ provides the most accurate predictions.

METHOD	$T_0 = T(0, 120 \text{ s})$	$T_2 = T(0.15 \text{ m}, 120 \text{ s})$
Explicit ($ Fo = \frac{1}{2} $)	125.3	48.1
Explicit ($ Fo = \frac{1}{4} $)	118.9	44.4
Implicit ($ Fo = \frac{1}{2} $)	114.7	44.2
Exact	120.0	45.4

This is not unexpected, since the corresponding value of Δt is 50% smaller than that used in the other two methods.

2. Although computations are simplified by using the maximum allowable value of Fo in the explicit method, the accuracy of the results is seldom satisfactory.
3. Note that the coefficient matrix $[A]$ is *tridiagonal*. That is, all elements are zero except those which are on, or to either side of, the main diagonal. Tridiagonal matrices are associated with one-dimensional conduction problems. In such cases the problem of solving for the unknown temperatures is greatly simplified, and stock computer programs may readily be obtained for this purpose.
4. A more general radiative heating condition would be one in which the surface is suddenly exposed to large surroundings at an elevated temperature T_{sur} (Problem 5.84). The net rate at which radiation is transferred to the surface may then be calculated from Equation 1.7. Allowing for convection heat transfer to the surface, application of conservation of energy to the surface node yields an explicit finite-

5.10 S

Tran
imp
cert
tran
If th
met
How
be c
avai
infr
whe
form
finit
used

REFER

- 1.
- 2.
- 3.
- 4.

difference equation of the form

$$\epsilon\sigma [T_{\text{sur}}^4 - (T_0^p)^4] + h(T_\infty - T_0^p) + k \frac{T_1^p - T_0^p}{\Delta x} = \rho \frac{\Delta x}{2} c \frac{T_0^{p+1} - T_0^p}{\Delta t}$$

Use of this finite-difference equation in a numerical solution is complicated by the fact that it is *nonlinear*. However, the equation may be *linearized* by introducing the radiation heat transfer coefficient h_r , defined by Equation 1.9, and the finite-difference equation is

$$h_r^p (T_{\text{sur}} - T_0^p) + h(T_\infty - T_0^p) + k \frac{T_1^p - T_0^p}{\Delta x} = \rho \frac{\Delta x}{2} c \frac{T_0^{p+1} - T_0^p}{\Delta t}$$

The solution may proceed in the usual manner, although the effect of a radiative Biot number ($Bi_r \equiv h_r \Delta x / k$) must be included in the stability criterion and the value of h_r must be updated at each step in the calculations. If the implicit method is used, h_r is calculated at $p + 1$, in which case an iterative calculation must be made at each time step.

5.10 SUMMARY

Transient conduction occurs in numerous engineering applications, and it is important to appreciate the different methods for dealing with it. There is certainly much to be said for simplicity, in which case, when confronted with a transient problem, the first thing you should do is calculate the Biot number. If this number is much less than unity, you may use the lumped capacitance method to obtain accurate results with minimal computational requirements. However, if the Biot number is not much less than unity, spatial effects must be considered, and some other method must be used. Analytical results are available in convenient graphical and equation form for the plane wall, the infinite cylinder, the sphere, and the semi-infinite solid. You should know when and how to use these results. If geometrical complexities and/or the form of the boundary conditions preclude their use, recourse must be made to finite-difference methods. With the digital computer, such methods may be used to solve any conduction problem, regardless of complexity.

REFERENCES

1. Carslaw, H. S., and J. C. Jaeger, *Conduction of Heat in Solids*, 2nd ed., Oxford University Press, London, 1959.
2. Schneider, P. J., *Conduction Heat Transfer*, Addison-Wesley, Reading, MA, 1955.
3. Arpaci, V. S., *Conduction Heat Transfer*, Addison-Wesley, Reading, MA, 1966.
4. Özisik, M. N., *Heat Conduction*, Wiley, New York, 1980.

5. Heisler, M. P., "Temperature Charts for Induction and Constant Temperature Heating," *Trans. ASME*, **69**, 227-236, 1947. 5.3
6. Gröber, H., S. Erk, and U. Grigull, *Fundamentals of Heat Transfer*, McGraw-Hill, New York, 1961.
7. Langston, L. S., "Heat Transfer from Multidimensional Objects Using One-Dimensional Solutions for Heat Loss," *Int. J. Heat Mass Transfer*, **25**, 149-150, 1982.
8. Richtmyer, R. D., and K. W. Morton, *Difference Methods for Initial Value Problems*, Wiley-Interscience, New York, 1967.
9. Myers, G. E., *Analytical Methods in Conduction Heat Transfer*, McGraw-Hill, New York, 1971.
10. Adams, J. A., and D. F. Rogers, *Computer-Aided Heat Transfer Analysis*, McGraw-Hill, New York, 1973. 5.4

PROBLEMS

Qualitative Considerations

- 5.1 Consider a thin electrical heater attached to a plate and backed by insulation. Initially, the heater and plate are at the temperature of the ambient air, T_∞ . Suddenly, the power to the heater is switched on giving rise to a constant heat flux q_o'' (W/m^2) at the inner surface of the plate.

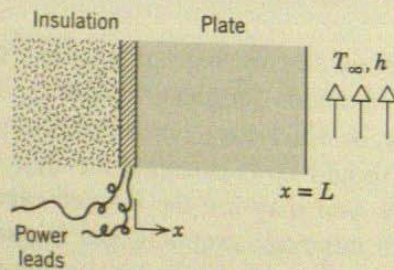

- (a) Sketch and label, on $T-x$ coordinates, the temperature distributions: initial, steady-state, and at two intermediate times.
 - (b) Sketch the heat flux at the outer surface $q_x''(L, t)$ as a function of time.
- 5.2 The inner surface of a plane wall is insulated while the outer surface is exposed to an airstream at T_∞ . The wall is at a uniform temperature corresponding to that of the airstream. Suddenly, a radiation heat source is switched on applying a uniform flux q_o'' to the outer surface. 5.6

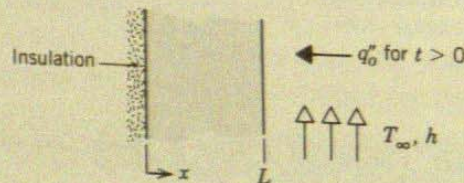

- (a) Sketch and label, on $T-x$ coordinates, the temperature distributions: initial, steady-state, and at two intermediate times.
- (b) Sketch the heat flux at the outer surface $q_x''(L, t)$ as a function of time. 5.7

- 5.3 A microwave oven operates on the principle that application of a high frequency field causes electrically polarized molecules in food to oscillate. The net effect is a *uniform generation* of thermal energy within the food, which enables it to be heated from refrigeration temperatures to 90°C in as short a time as 30 s.
- Consider the process of cooking a slab of beef of thickness $2L$ in a microwave oven and compare it with cooking in a conventional oven, where *each side* of the slab is *heated by radiation* for a period of approximately 30 min. In each case the meat is to be heated from 0°C to a *minimum* temperature of 90°C . Base your comparison on a sketch of the temperature distribution at selected times for each of the cooking processes. In particular consider the time t_0 at which heating is initiated, a time t_1 during the heating process, the time t_2 corresponding to the conclusion of heating, and a time t_3 well into the subsequent cooling process.
- 5.4 A plate of thickness $2L$, surface area A_s , mass M , and specific heat c_p , initially at a uniform temperature T_i , is suddenly heated on both surfaces by a convection process (T_{∞}, h) for a period of time t_o , following which the plate is insulated. Assume that the midplane temperature does not reach T_{∞} within this period of time.
- Assuming $Bi \gg 1$ for the heating process, sketch and label, on T - x coordinates, the following temperature distributions: initial, steady-state ($t \rightarrow \infty$), $T(x, t_o)$, and at two intermediate times between $t = t_o$ and $t \rightarrow \infty$.
 - Sketch and label, on T - t coordinates, the midplane and exposed surface temperature distributions.
 - Repeat parts a and b assuming $Bi \ll 1$ for the plate.
 - Derive an expression for the steady-state temperature $T(x, \infty) = T_f$, leaving your result in terms of plate parameters (M, c_p), thermal conditions (T_i, T_{∞}, h), the surface temperature $T(L, t)$, and the heating time t_o .

Lumped Capacitance Method

- 5.5 Steel balls 12 mm in diameter are annealed by heating to 1150 K and then slowly cooling to 400 K in an air environment for which $T_{\infty} = 325$ K and $h = 20$ $\text{W}/\text{m}^2 \cdot \text{K}$. Assuming the properties of the steel to be $k = 40$ $\text{W}/\text{m} \cdot \text{K}$, $\rho = 7800$ kg/m^3 , and $c = 600$ $\text{J}/\text{kg} \cdot \text{K}$, estimate the time required for the cooling process.
- 5.6 The heat transfer coefficient for air flowing over a sphere is to be determined by observing the temperature-time history of a sphere fabricated from pure copper. The sphere, which is 12.7 mm in diameter, is at 66°C before it is inserted into an airstream having a temperature of 27°C . A thermocouple on the outer surface of the sphere indicates 55°C 69 s after the sphere is inserted in the airstream. Assume, and then justify, that the sphere behaves as a spacewise isothermal object and calculate the heat transfer coefficient.
- 5.7 A solid steel sphere (AISI 1010), 300 mm in diameter, is coated with a dielectric material layer of thickness 2 mm and thermal conductivity 0.04 $\text{W}/\text{m} \cdot \text{K}$. The coated sphere is initially at a uniform temperature of 500°C and is suddenly quenched in a large oil bath for which $T_{\infty} = 100^{\circ}\text{C}$ and $h = 3300$ $\text{W}/\text{m}^2 \cdot \text{K}$. Estimate the time required for the coated sphere temperature to reach 140°C . *Hint:* Neglect the effect of energy storage in the dielectric material, since its thermal capacitance ($\rho c V$) is small compared to that of the steel sphere.

- 5.8 A spherical lead bullet of 6 mm diameter is moving at a Mach number of approximately 3. The resulting shock wave heats the air around the bullet to 700 K, and the average convection coefficient for heat transfer between the air and the bullet is $500 \text{ W/m}^2 \cdot \text{K}$. If the bullet leaves the barrel at 300 K and the time of flight is 0.4 s, what is its surface temperature on impact?
- 5.9 Carbon steel (AISI 1010) shafts of 0.1 m diameter are heat treated in a gas-fired furnace whose gases are at 1200 K and provide a convection coefficient of $100 \text{ W/m}^2 \cdot \text{K}$. If the shafts enter the furnace at 300 K, how long must they remain in the furnace to achieve a centerline temperature of 800 K?
- 5.10 A thermal energy storage unit consists of a large rectangular channel, which is well insulated on its outer surface and encloses alternating layers of the storage material and the flow passage.

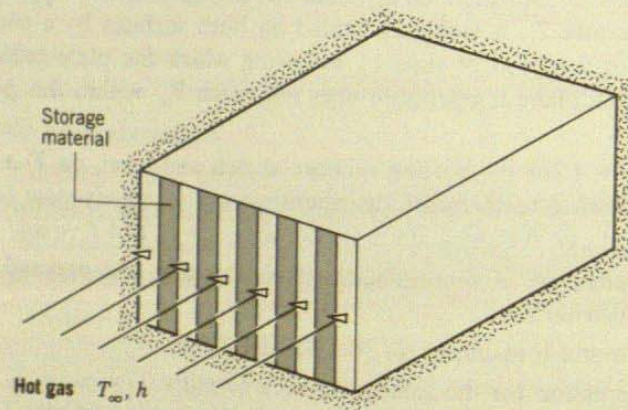

- Each layer of the storage material is an aluminum slab of width $W = 0.05 \text{ m}$, which is at an initial temperature of 25°C . Consider conditions for which the storage unit is charged by passing a hot gas through the passages, with the gas temperature and the convection coefficient assumed to have constant values of $T_\infty = 600^\circ\text{C}$ and $h = 100 \text{ W/m}^2 \cdot \text{K}$ throughout the channel. How long will it take to achieve 75% of the maximum possible energy storage? What is the temperature of the aluminum at this time?
- 5.11 A leaf spring of dimensions 32 mm by 10 mm by 1.1 m is sprayed with a thin anticorrosion coating which is heat treated by suspending the spring vertically in the lengthwise direction and passing it through a conveyor oven maintained at an air temperature of 175°C . Satisfactory coatings have been obtained on springs, initially at 25°C , with an oven residence time of 35 min. The coating supplier has specified that the coating should be treated for 10 min above a temperature of 140°C . How long should a spring of dimensions 76 mm by 35 mm by 1.6 m remain in the oven in order to properly heat treat the coating? The thermophysical properties of the spring material are $\rho = 8131 \text{ kg/m}^3$, $c_p = 473 \text{ J/kg} \cdot \text{K}$, and $k = 42 \text{ W/m} \cdot \text{K}$.
- 5.12 A 3-mm-thick panel of aluminum alloy ($k = 177 \text{ W/m} \cdot \text{K}$ and $\alpha = 73 \times 10^{-6} \text{ m}^2/\text{s}$) is finished on both sides with an epoxy coating that must be cured at or above 150°C for at least 5 min. The production line for the curing operation involves two steps: (1) heating in an oven with air at 175°C and a convection

coefficient of $20 \text{ W/m}^2 \cdot \text{K}$, and (2) cooling in an enclosure with air at 25°C and a convection coefficient of $10 \text{ W/m}^2 \cdot \text{K}$.

- (a) Assuming the panel is initially at 25°C , what is the minimum residence time for the panel in the oven?
- (b) What is the total elapsed time for the two-step curing operation if it is completed when the panel has been cured and cooled to the *safe-to-touch* temperature of 37°C ?
- 5.13 A plane wall of a furnace is fabricated from plain carbon steel ($k = 60 \text{ W/m} \cdot \text{K}$, $\rho = 7850 \text{ kg/m}^3$, $c = 430 \text{ J/kg} \cdot \text{K}$) and is of thickness $L = 10 \text{ mm}$. To protect it from the corrosive effects of the furnace combustion gases, one surface of the wall is coated with a thin ceramic film which, for a unit surface area, has a thermal resistance of $R''_{t,f} = 0.01 \text{ m}^2 \cdot \text{K/W}$. The opposite surface is well insulated from the surroundings.

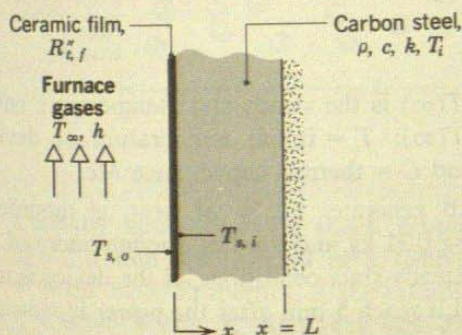

At furnace start-up the wall is at an initial temperature of $T_i = 300 \text{ K}$, and combustion gases at $T_\infty = 1300 \text{ K}$ enter the furnace, providing a convection coefficient of $h = 25 \text{ W/m}^2 \cdot \text{K}$ at the ceramic film. Assuming the film to have negligible thermal capacitance, how long will it take for the inner surface of the steel to achieve a temperature of $T_{s,i} = 1200 \text{ K}$? What is the temperature $T_{s,o}$ of the exposed surface of the ceramic film at this time?

- 5.14 In an industrial process requiring high dc currents, water-jacketed copper rods, 20 mm in diameter, are used to carry the current. The water, which flows continuously between the jacket and the rod, maintains the rod temperature at 75°C during normal operation at 1000 A. The electrical resistance of the rod is known to be $0.15 \Omega/\text{m}$. Problems would arise if the coolant water ceased to be available (e.g. because of a valve malfunction). In such a situation heat transfer from the rod surface would diminish greatly, and the rod would eventually melt. Estimate the time required for melting to occur.
- 5.15 A long wire of diameter $D = 1 \text{ mm}$ is submerged in an oil bath of temperature $T_\infty = 25^\circ\text{C}$. The wire has an electrical resistance per unit length of $R'_e = 0.01 \Omega/\text{m}$. If a current of $I = 100 \text{ A}$ flows through the wire and the convection coefficient is $h = 500 \text{ W/m}^2 \cdot \text{K}$, what is the steady-state temperature of the wire? From the time the current is applied, how long does it take for the wire to reach a temperature which is within 1°C of the steady-state value? The properties of the wire are $\rho = 8000 \text{ kg/m}^3$, $c = 500 \text{ J/kg} \cdot \text{K}$, and $k = 20 \text{ W/m} \cdot \text{K}$.
- 5.16 Consider the system of Problem 5.1 where the temperature of the plate is spacewise isothermal during the transient process.

- (a) Obtain an expression for the temperature of the plate as a function of time $T(t)$ in terms of q_o'', T_∞, h, L , and the plate properties ρ and c .
- (b) Determine the thermal time constant and the steady-state temperature for a 12-mm-thick plate of pure copper when $T_\infty = 27^\circ\text{C}$, $h = 50 \text{ W/m}^2 \cdot \text{K}$, and $q_o'' = 5000 \text{ W/m}^2$. Estimate the time required to reach steady-state conditions.
- 5.17 An electronic device, such as a power transistor mounted on a finned heat sink, can be modeled as a spatially isothermal object with internal heat generation and an external convection resistance.

- (a) Consider such a system of mass M , specific heat c , and surface area A_s , which is initially in equilibrium with the environment at T_∞ . Suddenly, the electronic device is energized such that a constant heat generation \dot{E}_g (W) occurs. Show that the temperature response of the device is

$$\frac{\theta}{\theta_i} = \exp\left(-\frac{t}{RC}\right)$$

where $\theta \equiv T - T(\infty)$ and $T(\infty)$ is the steady-state temperature corresponding to $t \rightarrow \infty$; $\theta_i = T_i - T(\infty)$; T_i = initial temperature of device; R = thermal resistance $1/\bar{h}A_s$; and C = thermal capacitance Mc .

- (b) An electronic device, which generates 60 W of heat, is mounted on an aluminum heat sink weighing 0.31 kg and reaches a temperature of 100°C in ambient air at 20°C under steady-state conditions. If the device is initially at 20°C , what temperature will it reach 5 min after the power is switched on?
- 5.18 Before being injected into a furnace, pulverized coal is preheated by passing it through a cylindrical tube whose surface is maintained at $T_{\text{sur}} = 1000^\circ\text{C}$. The coal pellets are suspended in an airflow and are known to move with a speed of 3 m/s. If the pellets may be approximated as spheres of 1-mm diameter and it may be assumed that they are heated by radiation transfer from the tube surface, how long must the tube be to heat coal entering at 25°C to a temperature of 600°C ? Is the use of the lumped capacitance method justified? 5.21
- 5.19 A metal sphere of diameter D , which is at a uniform temperature T_i , is suddenly removed from a furnace and suspended from a fine wire in a large room with air at a uniform temperature T_∞ and the surrounding walls at a temperature T_{sur} .
- (a) Neglecting heat transfer by radiation, obtain an expression for the time required to cool the sphere to some temperature T .
- (b) Neglecting heat transfer by convection, obtain an expression for the time required to cool the sphere to the temperature T . 5.22
- (c) How would you go about determining the time required for the sphere to cool to the temperature T if both convection and radiation are of the same order of magnitude?
- (d) Consider an anodized aluminum sphere ($\epsilon = 0.75$) 50 mm in diameter, which is at an initial temperature of $T_i = 800 \text{ K}$. Both the air and the surroundings are at 300 K, and the convection coefficient is $10 \text{ W/m}^2 \cdot \text{K}$. Calculate and compare the time it will take for the sphere to cool to 400 K using the results of parts a, b, and c.
- 5.20 As permanent space stations increase in size, there is an attendant increase in the amount of electrical power they dissipate. To keep station compartment temperatures from exceeding prescribed limits, it is necessary to transfer the dissipated

heat to space. A novel heat rejection scheme that has been proposed for this purpose is termed a Liquid Droplet Radiator (LDR). The heat is first transferred to a high vacuum oil, which is then injected into outer space as a stream of small droplets. The stream is allowed to traverse a distance L , over which it cools by radiating energy to outer space at absolute zero temperature. The droplets are then collected and routed back to the space station.

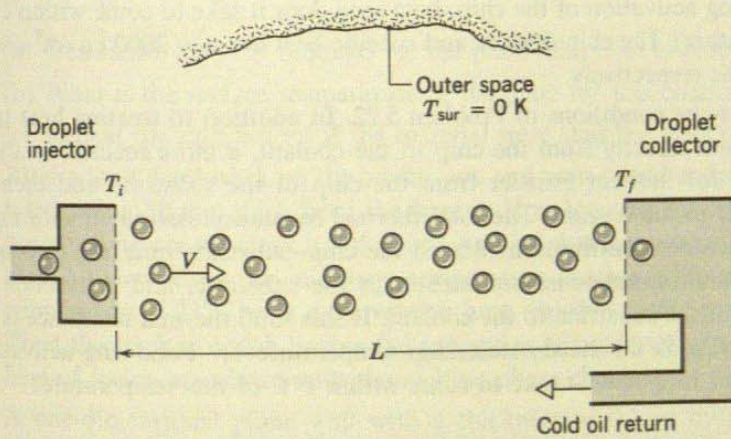

Consider conditions for which droplets of emissivity $\epsilon = 0.95$ and diameter $D = 0.5$ mm are injected at a temperature of $T_i = 500$ K and a velocity of $V = 0.1$ m/s. Properties of the oil are $\rho = 885$ kg/m³, $c = 1900$ J/kg · K, and $k = 0.145$ W/m · K. Assuming each drop to radiate to deep space at $T_{sur} = 0$ K, determine the distance L required for the droplets to impact the collector at a final temperature of $T_f = 300$ K. What is the amount of thermal energy rejected by each droplet?

- 5.21 Long metallic rods of circular cross section are heat treated by passing an electric current through the rods to provide uniform volumetric heat generation at a rate \dot{q} (W/m³). The rods are of diameter D and are placed in a large chamber whose walls are maintained at the same temperature T_∞ as the enclosed air. Convection from the surface of the rods to the air is characterized by the coefficient h .
- Obtain an expression that could be used to determine the steady-state temperature of the rod.
 - Neglecting radiation and prescribing an initial ($t = 0$) rod temperature of $T_i = T_\infty$, obtain the transient temperature response of the rod.
- 5.22 A chip that is of length $L = 5$ mm on a side and thickness $t = 1$ mm is encased in a ceramic substrate, and its exposed surface is convectively cooled by a dielectric liquid for which $h = 150$ W/m² · K and $T_\infty = 20^\circ\text{C}$.

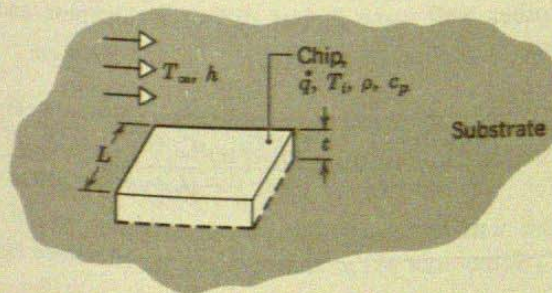

LIBRARY U. OF I. URBANA-CHAMPAIGN

In the off-mode the chip is in thermal equilibrium with the coolant ($T_i = T_\infty$). When the chip is energized, however, its temperature increases until a new steady-state is established. For purposes of analysis, the energized chip is characterized by uniform volumetric heating with $\dot{q} = 9 \times 10^6 \text{ W/m}^3$. Assuming an infinite contact resistance between the chip and substrate and negligible conduction resistance within the chip, determine the steady-state chip temperature T_f . Following activation of the chip, how long does it take to come within 1°C of this temperature? The chip density and specific heat are $\rho = 2000 \text{ kg/m}^3$ and $c = 700 \text{ J/kg} \cdot \text{K}$, respectively.

5.26

5.23 Consider the conditions of Problem 5.22. In addition to treating heat transfer by convection directly from the chip to the coolant, a more realistic analysis would account for indirect transfer from the chip to the substrate and then from the substrate to the coolant. The total thermal resistance associated with this indirect route includes contributions due to the chip-substrate interface (a contact resistance), multidimensional conduction in the substrate, and convection from the surface of the substrate to the coolant. If this total thermal resistance is $R_t = 200 \text{ K/W}$, what is the steady-state chip temperature T_f ? Following activation of the chip, how long does it take to come within 1°C of this temperature?

5.27

5.28

One-Dimensional Conduction: The Plane Wall

5.24 Consider the series solution, Equation 5.39, for the plane wall with convection. Calculate midplane ($x^* = 0$) and surface ($x^* = 1$) temperatures θ^* for $Fo = 0.1$ and 1, using $Bi = 0.1, 1,$ and 10. Consider only the first four eigenvalues. Based on these results discuss the validity of the approximate solutions, Equations 5.40 and 5.41.

5.29

5.25 Consider the one-dimensional wall shown in the sketch which is initially at a uniform temperature T_i and is suddenly subjected to the convection boundary condition with a fluid at T_∞ .

5.30

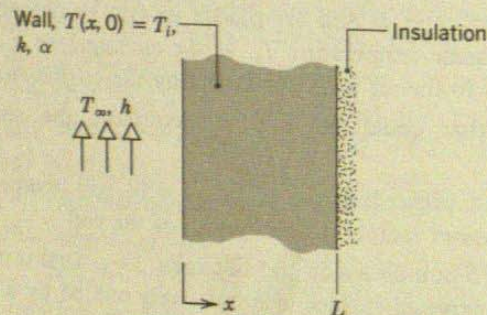

For a particular wall, case 1, the temperature at $x = L_1$ after $t_1 = 100 \text{ s}$ is $T_1(L_1, t_1) = 315^\circ\text{C}$. Another wall, case 2, has different thickness and thermal conditions as shown below.

CASE	L (m)	α (m^2/s)	k ($\text{W}/\text{m} \cdot \text{K}$)	T_i ($^\circ\text{C}$)	T_∞ ($^\circ\text{C}$)	h ($\text{W}/\text{m}^2 \cdot \text{K}$)
1	0.10	15×10^{-6}	50	300	400	200
2	0.40	25×10^{-6}	100	30	20	100

5.31

How long will it take for the second wall to reach 28.5°C at the position $x = L_2$? Use as the basis for analysis, the dimensionless functional dependence for transient temperature distribution as expressed in Equation 5.26.

- 5.26 A large aluminum (2024 alloy) plate of thickness 0.15 m , initially at a uniform temperature of 300 K , is placed in a furnace having an ambient temperature of 800 K for which the convection heat transfer coefficient is estimated to be $500\text{ W/m}^2 \cdot \text{K}$.
- Determine the time required for the plate midplane to reach 700 K .
 - What is the surface temperature of the plate for this condition?
 - Repeat the calculations if the material were stainless steel (type 304).
- 5.27 After a long, hard week on the books, you and your friend are ready to relax. You take a steak 50 mm thick from the freezer. How long do you have to let the good times roll before the steak has thawed? Assume that the steak is initially at -6°C , that it thaws when the midplane temperature reaches 4°C , and that the room temperature is 23°C with a convection heat transfer coefficient of $10\text{ W/m}^2 \cdot \text{K}$. Treat the steak as a slab having the properties of liquid water at 0°C . Neglect the heat of fusion associated with the melting phase change.
- 5.28 A one-dimensional plane wall with a thickness of 0.1 m initially at a uniform temperature of 250°C is suddenly immersed in an oil bath at 30°C . Assuming the convection heat transfer coefficient for the wall in the bath is $500\text{ W/m}^2 \cdot \text{K}$, calculate the surface temperature of the wall 9 min after immersion. The properties of the wall are $k = 50\text{ W/m} \cdot \text{K}$, $\rho = 7835\text{ kg/m}^3$, and $c = 465\text{ J/kg} \cdot \text{K}$.
- 5.29 Consider the thermal energy storage unit of Problem 5.10, but with a masonry material of $\rho = 1900\text{ kg/m}^3$, $c = 800\text{ J/kg} \cdot \text{K}$, and $k = 0.70\text{ W/m} \cdot \text{K}$ used in place of the aluminum. How long will it take to achieve 75% of the maximum possible energy storage? What are the maximum and minimum temperatures of the masonry at this time?
- 5.30 The wall of a rocket nozzle is of thickness $L = 25\text{ mm}$ and is made from a high alloy steel for which $\rho = 8000\text{ kg/m}^3$, $c = 500\text{ J/kg} \cdot \text{K}$, and $k = 25\text{ W/m} \cdot \text{K}$. During a test firing, the wall is initially at $T_i = 25^\circ\text{C}$ and its inner surface is exposed to hot combustion gases for which $h = 500\text{ W/m}^2 \cdot \text{K}$ and $T_\infty = 1750^\circ\text{C}$. The outer surface is well insulated.

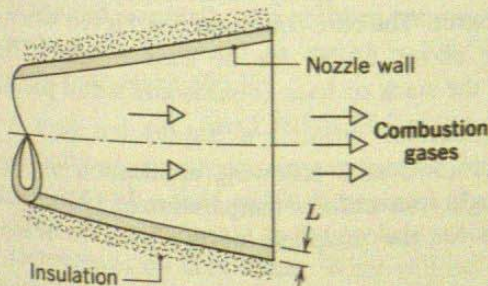

If the wall must be maintained at least 100°C below its melting point of $T_{\text{mp}} = 1600^\circ\text{C}$, what is the maximum allowable firing time t_f ? The diameter of the nozzle is much larger than its thickness L .

- 5.31 In a tempering process, glass plate, which is initially at a uniform temperature T_i , is cooled by suddenly reducing the temperature of both surfaces to T_s . The plate is

20 mm thick, and the glass has a thermal diffusivity of $6 \times 10^{-7} \text{ m}^2/\text{s}$.

- (a) How long will it take for the midplane temperature to achieve 50% of its maximum possible temperature reduction?
- (b) If $(T_i - T_s) = 300^\circ\text{C}$, what is the maximum temperature gradient in the glass at the above time?

One-Dim

5.34

- 5.32 Copper-coated, epoxy-filled fiberglass circuit boards are treated by heating a stack of them under high pressure as shown in the sketch. The purpose of the pressing-heating operation is to cure the epoxy which bonds the fiberglass sheets imparting stiffness to the boards. The stack, referred to as a *book*, is comprised of 10 *boards* and 11 *pressing plates* which prevent epoxy from flowing between the boards and impart a smooth finish to the cured boards. In order to perform simplified thermal analyses, it is reasonable to approximate the book as having an effective thermal conductivity (k) and an effective thermal capacitance (ρc_p). Calculate the effective properties if each of the boards and plates has a thickness of 2.36 mm and the following thermophysical properties: board (b) $\rho_b = 1000 \text{ kg/m}^3$, $c_{p,b} = 1500 \text{ J/kg} \cdot \text{K}$, $k_b = 0.30 \text{ W/m} \cdot \text{K}$; plate (p) $\rho_p = 8000 \text{ kg/m}^3$, $c_{p,p} = 480 \text{ J/kg} \cdot \text{K}$, $k_p = 12 \text{ W/m} \cdot \text{K}$.

5.35

5.36

5.37

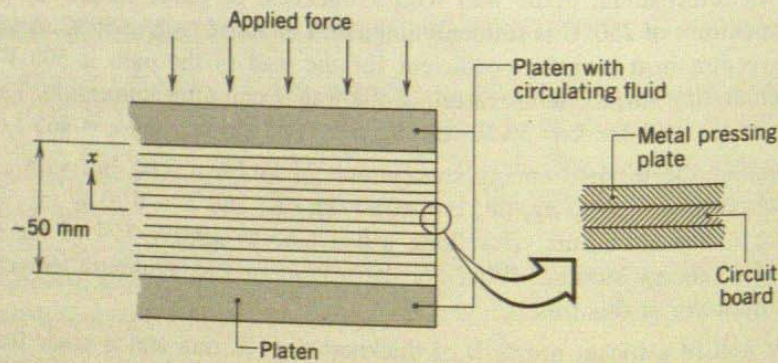

5.38

- 5.33 Circuit boards are treated by heating a stack of them under high pressure as illustrated in Problem 5.32. The platens at the top and bottom of the stack are maintained at a uniform temperature by a circulating fluid. The purpose of the pressing-heating operation is to cure the epoxy which bonds the fiberglass sheets and impart stiffness to the boards. The cure condition is achieved when the epoxy has been maintained at or above 170°C for at least 5 min. The effective thermophysical properties of the stack or *book* (boards and metal pressing plates) are $k = 0.613 \text{ W/m} \cdot \text{K}$ and $\rho c_p = 2.73 \times 10^6 \text{ J/m}^3 \cdot \text{K}$.

5.39

- (a) If the book is initially at 15°C and, following application of pressure, the platens are suddenly brought to a uniform temperature of 190°C , calculate the elapsed time t_e required for the midplane of the book to reach the cure temperature of 170°C .
- (b) If, at this instant of time, $t = t_e$, the platen temperature were reduced suddenly to 15°C , how much energy would have to be removed from the book by the coolant circulating in the platen, in order to return the stack to its initial uniform temperature?

5.40

One-Dimensional Conduction: The Long Cylinder

- 5.34 Cylindrical steel rods (AISI 1010), 50 mm in diameter, are heat treated by drawing them through an oven 5 m long in which air is maintained at 750°C. The rods enter at 50°C and achieve a centerline temperature of 600°C before leaving. For a convection coefficient of 125 W/m² · K, estimate the speed at which the rods must be drawn through the oven.
- 5.35 Estimate the time required to cook a hot dog in boiling water. Assume that the hot dog is initially at 6°C, that the convection heat transfer coefficient is 100 W/m² · K, and that the final temperature is 80°C at the centerline. Treat the hot dog as a long cylinder of 20-mm diameter having the properties: $\rho = 880 \text{ kg/m}^3$, $c = 3350 \text{ J/kg} \cdot \text{K}$, and $k = 0.52 \text{ W/m} \cdot \text{K}$.
- 5.36 A long rod of 60-mm diameter and thermophysical properties $\rho = 8000 \text{ kg/m}^3$, $c = 500 \text{ J/kg} \cdot \text{K}$ and $k = 50 \text{ W/m} \cdot \text{K}$ is initially at a uniform temperature and is heated in a forced convection furnace maintained at 750 K. The convection coefficient is estimated to be 1000 W/m² · K. At a certain time, the surface temperature of the rod is measured to be 550 K. What is the corresponding center temperature of the rod?
- 5.37 A long cylinder of 30-mm diameter, initially at a uniform temperature of 1000 K, is suddenly quenched in a large, constant-temperature oil bath at 350 K. The cylinder properties are $k = 1.7 \text{ W/m} \cdot \text{K}$, $c = 1600 \text{ J/kg} \cdot \text{K}$, and $\rho = 400 \text{ kg/m}^3$, while the convection coefficient is 50 W/m² · K. Calculate the time required for the surface of the cylinder to reach 500 K.
- 5.38 A long pyroceram rod of diameter 20 mm is clad with a very thin metallic tube for mechanical protection. The bonding between the rod and the tube has a thermal contact resistance of $R'_{t,c} = 0.12 \text{ m} \cdot \text{K/W}$.

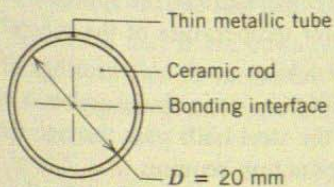

If the rod is initially at a uniform temperature of 900 K and is suddenly cooled by a fluid at $T_\infty = 300 \text{ K}$ and $h = 100 \text{ W/m}^2 \cdot \text{K}$, at what time will the rod centerline reach 600 K?

- 5.39 A long rod 40 mm in diameter, fabricated from sapphire (aluminum oxide) and initially at a uniform temperature of 800 K, is suddenly exposed to a cooling process with a fluid at 300 K having a heat transfer coefficient of 1600 W/m² · K. After 35 s of exposure to the cooling process, the rod is wrapped in insulation and experiences no heat losses. What will be the temperature of the rod after a long period of time?
- 5.40 A long bar of 70-mm diameter and initially at 90°C is cooled by immersing it in a water bath which is at 40°C and provides a convection coefficient of 20 W/m² · K. The thermophysical properties of the bar are $\rho = 2600 \text{ kg/m}^3$, $c = 1030 \text{ J/kg} \cdot \text{K}$, and $k = 3.50 \text{ W/m} \cdot \text{K}$.

LIBRARY U. OF I. URBANA-CHAMPAIGN

- (a) How long should the bar remain in the bath in order that, when it is removed and allowed to equilibrate while isolated from any surroundings, it achieves a uniform temperature of 55°C ?
- (b) What is the surface temperature of the bar when it is removed from the bath?
- 5.41 A long plastic rod of 30-mm diameter ($k = 0.3 \text{ W/m} \cdot \text{K}$ and $\rho c_p = 1040 \text{ kJ/m}^3 \cdot \text{K}$) is uniformly heated in an oven as preparation for a pressing operation. For best results, the temperature in the rod should not be less than 200°C . To what uniform temperature should the rod be heated in the oven if, for the worst case, the rod sits on a conveyor for 3 min while exposed to convection cooling with ambient air at 25°C and with a convection coefficient of $8 \text{ W/m}^2 \cdot \text{K}$? A further condition for good results is a maximum-minimum temperature difference of less than 10°C . Is this condition satisfied and, if not, what could you do to satisfy it?

One-Dimensional Conduction: The Sphere

- 5.42 In heat treating to harden steel ball bearings ($c = 500 \text{ J/kg} \cdot \text{K}$, $\rho = 7800 \text{ kg/m}^3$, $k = 50 \text{ W/m} \cdot \text{K}$), it is desirable to increase the surface temperature for a short time without significantly warming the interior of the ball. This type of heating can be accomplished by sudden immersion of the ball in a molten salt bath with $T_\infty = 1300 \text{ K}$ and $h = 5000 \text{ W/m}^2 \cdot \text{K}$. Assume that any location within the ball whose temperature exceeds 1000 K will be hardened. Estimate the time required to harden the outer millimeter of a ball of diameter 20 mm, if its initial temperature is 300 K .
- 5.43 A sphere of 80-mm diameter ($k = 50 \text{ W/m} \cdot \text{K}$ and $\alpha = 1.5 \times 10^{-6} \text{ m}^2/\text{s}$) is initially at a uniform, elevated temperature and is quenched in an oil bath maintained at 50°C . The convection coefficient for the cooling process is $1000 \text{ W/m}^2 \cdot \text{K}$. At a certain time, the surface temperature of the sphere is measured to be 150°C . What is the corresponding center temperature of the sphere?
- 5.44 A cold air chamber is proposed for quenching steel ball bearings of diameter $D = 0.2 \text{ m}$ and initial temperature $T_i = 400^\circ\text{C}$. Air in the chamber is maintained at -15°C by a refrigeration system, and the steel balls pass through the chamber on a conveyor belt. Optimum bearing production requires that 70% of the initial thermal energy content of the ball above -15°C be removed. Radiation effects may be neglected, and the convection heat transfer coefficient within the chamber is $1000 \text{ W/m}^2 \cdot \text{K}$. Estimate the residence time of the balls within the chamber, and recommend a drive velocity of the conveyor. The following properties may be used for the steel: $k = 50 \text{ W/m} \cdot \text{K}$, $\alpha = 2 \times 10^{-5} \text{ m}^2/\text{s}$, and $c = 450 \text{ J/kg} \cdot \text{K}$.

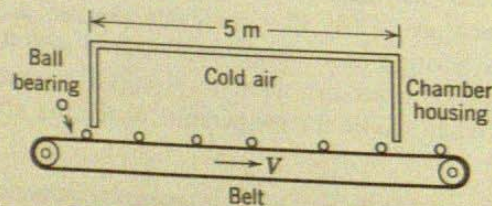

- 5.45 Stainless steel (AISI 304) ball bearings, which have been uniformly heated to 850°C , are hardened by quenching them in an oil bath that is maintained at 40°C . The ball diameter is 20 mm, and the convection coefficient associated with the oil bath is $1000 \text{ W/m}^2 \cdot \text{K}$.

- (a) If quenching is to occur until the surface temperature of the balls reaches 100°C , how long must the balls be kept in the oil? What is the center temperature at the conclusion of the cooling period?
- (b) If 10,000 balls are to be quenched per hour, what is the rate at which energy must be removed by the oil bath cooling system in order to maintain its temperature at 40°C ?
- 5.46 A spherical hailstone that is 5 mm in diameter is formed in a high altitude cloud at -30°C . If the stone begins to fall through warmer air at 5°C , how long will it take before the outer surface begins to melt? What is the temperature of the stone's center at this point in time, and how much energy (J) has been transferred to the stone? A convection heat transfer coefficient of $250 \text{ W/m}^2 \cdot \text{K}$ may be assumed, and the properties of the hailstone may be taken to be those of ice.
- 5.47 A sphere 30 mm in diameter initially at 800 K is quenched in a large bath having a constant temperature of 320 K with a convection heat transfer coefficient of $75 \text{ W/m}^2 \cdot \text{K}$. The thermophysical properties of the sphere material are: $\rho = 400 \text{ kg/m}^3$, $c = 1600 \text{ J/kg} \cdot \text{K}$, and $k = 1.7 \text{ W/m} \cdot \text{K}$.
- (a) Show, in a qualitative manner on $T-t$ coordinates, the temperatures at the center and at the surface of the sphere as a function of time.
- (b) Calculate the time required for the surface of the sphere to reach 415 K.
- (c) Determine the heat flux (W/m^2) at the outer surface of the sphere at the time determined in part b.
- (d) Determine the energy (J) that has been lost by the sphere during the process of cooling to the surface temperature of 415 K.
- (e) At the time determined by part b, the sphere is quickly removed from the bath and covered with perfect insulation, such that there is no heat loss from the surface of the sphere. What will be the temperature of the sphere after a long period of time has elapsed?
- 5.48 Spheres A and B are initially at 800 K, and they are simultaneously quenched in large constant temperature baths, each having a temperature of 320 K. The following parameters are associated with each of the spheres and their cooling processes.

	SPHERE A	SPHERE B
Diameter (mm)	300	30
Density (kg/m^3)	1600	400
Specific heat ($\text{kJ/kg} \cdot \text{K}$)	0.400	1.60
Thermal conductivity ($\text{W/m} \cdot \text{K}$)	170	1.70
Convection coefficient ($\text{W/m}^2 \cdot \text{K}$)	5	50

- (a) Show in a qualitative manner, on T versus t coordinates, the temperatures at the center and at the surface for each sphere as a function of time. Briefly explain the reasoning by which you determine the relative positions of the curves.
- (b) Calculate the time required for the surface of each sphere to reach 415 K.

LIBRARY U. OF I. URBANA-CHAMPAIGN

- (c) Determine the energy that has been gained by each of the baths during the process of the spheres cooling to 415 K.
- 5.49 The convection coefficient for flow over a solid sphere may be determined by submerging the sphere, which is initially at 25°C , into the flow, which is at 75°C , and measuring its surface temperature at some time during the transient heating process. The sphere has a diameter of 0.1 m, and its thermal conductivity and thermal diffusivity are $15 \text{ W/m}\cdot\text{K}$ and $10^{-5} \text{ m}^2/\text{s}$, respectively. If the convection coefficient is $300 \text{ W/m}^2\cdot\text{K}$, at what time will a surface temperature of 60°C be recorded?

Semi-infinite Media

- 5.50 Two large blocks of different materials, such as copper and concrete, have been sitting in a room (23°C) for a very long time. Which of the two blocks, if either, will feel colder to the touch? Assume the blocks to be semi-infinite solids and your hand to be at a temperature of 37°C .
- 5.51 Asphalt pavement may achieve temperatures as high as 50°C on a hot summer day. Assume that such a temperature exists throughout the pavement, when suddenly a rainstorm reduces the surface temperature to 20°C . Calculate the total amount of energy (J/m^2) that will be transferred from the asphalt over a 30-min period in which the surface is maintained at 20°C .
- 5.52 A furnace wall is fabricated from fireclay brick ($\alpha = 7.1 \times 10^{-7} \text{ m}^2/\text{s}$), and its inner surface is maintained at 1100 K during furnace operation. The wall is designed according to the criterion that, for an initial temperature of 300 K, its midpoint temperature will not exceed 325 K after 4 h of furnace operation. What is the minimum allowable wall thickness?
- 5.53 A block of material of thickness 20 mm with known thermophysical properties ($k = 15 \text{ W/m}\cdot\text{K}$ and $\alpha = 2.0 \times 10^{-5} \text{ m}^2/\text{s}$) is imbedded in the wall of a channel that is initially at 25°C and is suddenly subjected to a convection process with gases at 325°C . A thermocouple (TC) is installed 2 mm below the surface of the channel wall for the purpose of sensing the temperature–time history (following start-up of the hot gas flow) and thereby determining the transient heat flux. At an elapsed time of 10 s, the thermocouple indicates a temperature of 167°C .

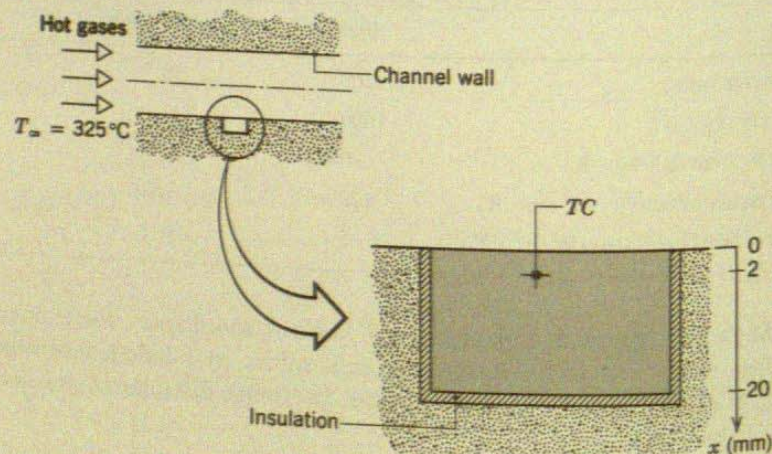

Calculate the corresponding surface convective heat flux assuming the block behaves as a semi-infinite solid. Compare this result with that obtained from the Heisler method of solution.

- 5.54 A tile-iron consists of a massive plate maintained at 150°C by an imbedded electrical heater. The iron is placed in contact with a tile to soften the adhesive, allowing the tile to be easily lifted from the subflooring. The adhesive will soften sufficiently if heated above 50°C for at least 2 min, but its temperature should not exceed 120°C to avoid deterioration of the adhesive. Assume the tile and subfloor to have an initial temperature of 25°C and to have equivalent thermophysical properties of $k = 0.15 \text{ W/m} \cdot \text{K}$ and $\rho c_p = 1.5 \times 10^6 \text{ J/m}^3 \cdot \text{K}$.

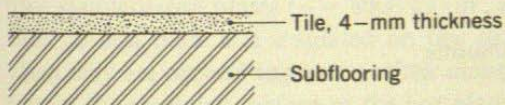

- (a) How long will it take a worker using the tile-iron to lift a tile? Will the adhesive temperature exceed 120°C ?
- (b) If the tile-iron has a square surface area 254 mm to the side, how much energy has been removed from it during the time it has taken to lift the tile?
- 5.55 The manufacturer of the heat flux gage of the type illustrated in Problem 1.8 claims the time constant for a 63.2% response to be $\tau = (4d^2\rho c_p)/\pi^2 k$, where ρ , c_p , and k are the thermophysical properties of the gage material and d is its thickness. Not knowing the origin of this relation, your task is to model the gage considering the two extreme cases illustrated below. In both cases, the gage, initially at a uniform temperature T_i , is exposed to a sudden change in surface temperature, $T(0, t) = T_s$. For case a the backside of the gage is insulated, and for case b the gage is imbedded in a semi-infinite solid having the same thermophysical properties as those of the gage.

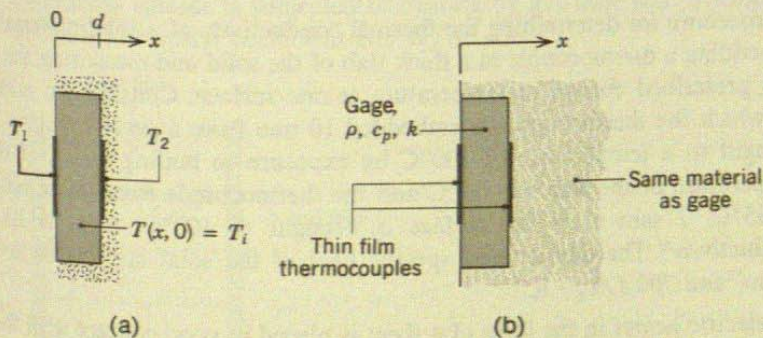

Develop relationships for predicting the time constant of the gage for the two cases and compare them to the manufacturer's relation. What conclusion can you draw from this analysis regarding the transient response of gages for different applications?

- 5.56 A simple procedure for measuring surface convection heat transfer coefficients involves coating the surface with a thin layer of material having a precise melting point temperature. The surface is then heated and, by determining the time required for melting to occur, the convection coefficient is determined. The

LIBRARY U. OF I. URBANA-CHAMPAIGN

following experimental arrangement uses the procedure to determine the convection coefficient for gas flow normal to a surface. Specifically, a long copper rod is encased in a super insulator of very low thermal conductivity, and a very thin coating is applied to its exposed surface.

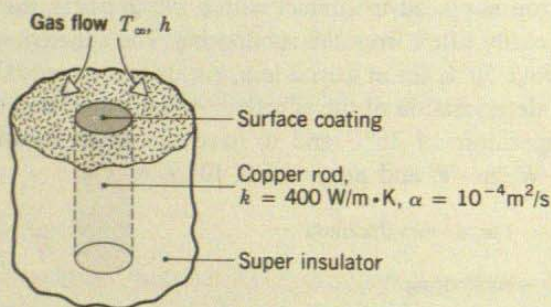

If the rod is initially at 25°C and gas flow for which $h = 200 \text{ W/m}^2 \cdot \text{K}$ and $T_{\infty} = 300^\circ\text{C}$ is initiated, what is the melting point temperature of the coating if melting is observed to occur at $t = 400 \text{ s}$?

- 5.57 An insurance company has hired you as a consultant to improve their understanding of burn injuries. They are especially interested in injuries induced when a portion of a worker's body comes into contact with machinery that is at elevated temperatures in the range of 50 to 100°C . Their medical consultant informs them that irreversible thermal injury (cell death) will occur in any living tissue that is maintained at $T \geq 48^\circ\text{C}$ for a duration $\Delta t \geq 10 \text{ s}$. They want information concerning the extent of irreversible tissue damage (as measured by distance from the skin surface) as a function of the machinery temperature and the time during which contact is made between the skin and the machinery. Can you help them? Assume that living tissue has a normal temperature of 37°C , is isotropic, and has constant properties equivalent to those of liquid water.
- 5.58 A procedure for determining the thermal conductivity of a solid material involves embedding a thermocouple in a thick slab of the solid and measuring the response to a prescribed change in temperature at one surface. Consider an arrangement for which the thermocouple is embedded 10 mm from a surface that is suddenly brought to a temperature of 100°C by exposure to boiling water. If the initial temperature of the slab was 30°C and the thermocouple measures a temperature of 65°C , 2 min after the surface is brought to 100°C , what is its thermal conductivity? The density and specific heat of the solid are known to be 2200 kg/m^3 and $700 \text{ J/kg}\cdot\text{K}$.
- 5.59 An electric heater in the form of a sheet is placed in good contact with the surface of a thick slab of Bakelite having a uniform temperature of 300 K . Determine the temperature of the slab at the surface and at a depth of 25 mm , 10 min after the heater has been energized and is providing a constant heat flux to the surface of 2500 W/m^2 .
- 5.60 A very thick slab with thermal diffusivity $5.6 \times 10^{-6} \text{ m}^2/\text{s}$ and thermal conductivity $20 \text{ W/m}\cdot\text{K}$ is initially at a uniform temperature of 325°C . Suddenly, the surface is exposed to a coolant at 15°C for which the convection heat transfer coefficient is $100 \text{ W/m}^2 \cdot \text{K}$. Determine the temperatures at the surface and at a depth of 45 mm after 3 min has elapsed.

- 5.61 A thick oak wall initially at 25°C , is suddenly exposed to combustion products at 800°C . Determine the time of exposure required for the surface to reach the ignition temperature of 400°C , assuming the convection heat transfer coefficient between the wall and products to be $20\text{ W/m}^2 \cdot \text{K}$.
- 5.62 It is well known that, although two materials are at the same temperature, one may feel cooler to the touch than the other. Consider thick plates of copper and glass, each at an initial temperature of 300 K . Assuming your finger to be at an initial temperature of 310 K and to have thermophysical properties of $\rho = 1000\text{ kg/m}^3$, $c = 4180\text{ J/kg} \cdot \text{K}$ and $k = 0.625\text{ W/m} \cdot \text{K}$, determine whether the copper or the glass will feel cooler to the touch.
- 5.63 Two stainless steel plates ($\rho = 8000\text{ kg/m}^3$, $c = 500\text{ J/kg} \cdot \text{K}$, $k = 15\text{ W/m} \cdot \text{K}$), each 20 mm thick and insulated on one surface, are initially at 400 and 300 K when they are pressed together at their uninsulated surfaces. What is the temperature of the insulated surface of the hot plate after 1 min has elapsed?

Multidimensional Conduction

- 5.64 A long steel (plain carbon) billet of square cross section 0.3 m by 0.3 m , initially at a uniform temperature of 30°C , is placed in a soaking oven having a temperature of 750°C . If the convection heat transfer coefficient for the heating process is $100\text{ W/m}^2 \cdot \text{K}$, how long must the billet remain in the oven before its center temperature reaches 600°C ?
- 5.65 Fireclay brick of dimensions $0.06\text{ m} \times 0.09\text{ m} \times 0.20\text{ m}$ is removed from a kiln at 1600 K and cooled in air at 40°C with $h = 50\text{ W/m}^2 \cdot \text{K}$. What is the temperature at the center and at the corners of the brick after 50 min of cooling?
- 5.66 A cylindrical copper pin 100 mm long and 50 mm in diameter is initially at a uniform temperature of 20°C . The end faces are suddenly subjected to an intense heating rate that raises them to a temperature of 500°C . At the same time, the cylindrical surface is subjected to heating by gas flow with a temperature 500°C and a heat transfer coefficient $100\text{ W/m}^2 \cdot \text{K}$.

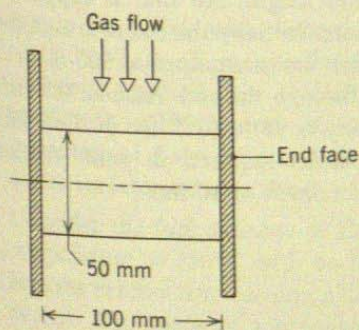

- (a) Determine the temperature at the center point of the cylinder 8 s after sudden application of the heat.
- (b) Considering the parameters governing the temperature distribution in transient heat diffusion problems, can any simplifying assumptions be justified in analyzing this particular problem? Explain briefly.
- 5.67 Recalling that your mother once said that meat should be cooked until every portion has attained a temperature of 80°C , how long will it take to cook a

LIBRARY U. OF I. URBANA-CHAMPAIGN

- 2.25-kg roast? Assume that the meat is initially at 6°C and that the oven temperature is 175°C with a convection heat transfer coefficient of $15\text{ W/m}^2 \cdot \text{K}$. Treat the roast as a cylinder with properties of liquid water, having a diameter equal to its length.
- 5.68 A long rod 20 mm in diameter is fabricated from alumina (polycrystalline aluminum oxide) and is initially at a uniform temperature of 850 K. The rod is suddenly exposed to fluid at 350 K with $h = 500\text{ W/m}^2 \cdot \text{K}$. Estimate the centerline temperature of the rod after 30 s at an exposed end and at an axial distance of 6 mm from the end.

Finite-Difference Solutions

- 5.69 The stability criterion for the explicit method requires that the coefficient of the T_m^p term of the one-dimensional, finite-difference equation be zero or positive. Consider the situation for which the temperatures at the two neighboring nodes (T_{m-1}^p, T_{m+1}^p) are 100°C while the center node (T_m^p) is at 50°C . Show that for values of $Fo > \frac{1}{2}$, the finite-difference equation will predict a value of T_m^{p+1} that violates the second law of thermodynamics.
- 5.70 A thin rod of diameter D is initially in equilibrium with its surroundings, a large vacuum enclosure at temperature, T_{sur} . Suddenly an electrical current I (A) is passed through the rod having an electrical resistivity ρ_e and emissivity ϵ . Other pertinent thermophysical properties are identified in the sketch. Derive the transient, finite-difference equation for node m .

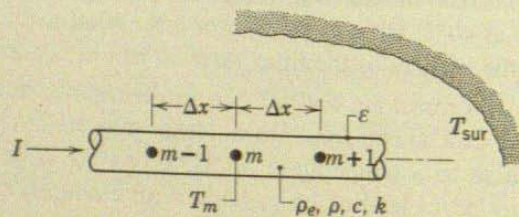

- 5.71 A tantalum rod of diameter 3 mm and length 120 mm is supported by two electrodes within a large vacuum enclosure. Initially the rod is in equilibrium with the electrodes and its surroundings, which are maintained at 300 K. Suddenly, an electrical current, $I = 80\text{ A}$, is passed through the rod. Assume the emissivity of the rod is 0.1 and the electrical resistivity is $95 \times 10^{-8}\ \Omega \cdot \text{m}$. Use Table A.1 to obtain the other thermophysical properties required in your solution. Use a finite-difference method with a space increment of 10 mm.

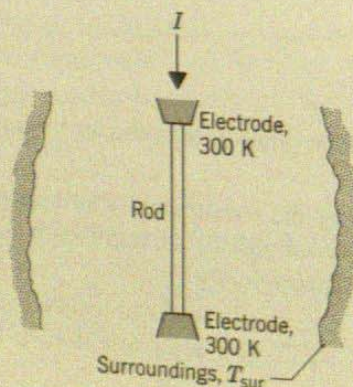

- (a) Estimate the time required for the midlength of the rod to reach 1000 K.
- (b) Determine the steady-state temperature distribution and estimate approximately how long it will take to reach this condition.

5.72 A one-dimensional slab of thickness $2L$ is initially at a uniform temperature T_i . Suddenly, electric current is passed through the slab causing a uniform volumetric heating \dot{q} (W/m^3). At the same time, both outer surfaces ($x = \pm L$) are subjected to a convection process at T_∞ with a heat transfer coefficient h .

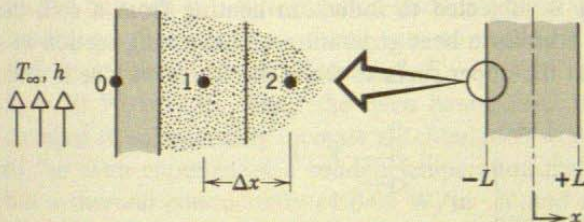

Write the finite-difference equation expressing conservation of energy for node 0 located on the outer surface at $x = -L$. Rearrange your equation and identify any important dimensionless coefficients.

- 5.73 A wall 0.12 m thick having a thermal diffusivity of $1.5 \times 10^{-6} \text{ m}^2/\text{s}$ is initially at a uniform temperature of 85°C . Suddenly one face is lowered to a temperature of 20°C , while the other face is perfectly insulated. Using a numerical method with space and time increments of 30 mm and 300 s, respectively, determine the temperature distribution within the wall after 45 min have elapsed.
- 5.74 A large plastic casting with thermal diffusivity $6.0 \times 10^{-7} \text{ m}^2/\text{s}$ is removed from its mold at a uniform temperature of 150°C . The casting is then exposed to a high-velocity airstream such that the surface experiences a sudden change in temperature to 20°C . Assuming the casting approximates a semi-infinite medium and using a finite-difference method with a space increment of 6 mm, estimate the temperature at a distance 18 mm from the surface after 3 min have elapsed. Verify your result by comparison with the appropriate analytical solution.
- 5.75 A very thick plate with thermal diffusivity $5.6 \times 10^{-6} \text{ m}^2/\text{s}$ and thermal conductivity $20 \text{ W}/\text{m} \cdot \text{K}$ is initially at a uniform temperature of 325°C . Suddenly, the surface is exposed to a coolant at 15°C for which the convection heat transfer coefficient is $100 \text{ W}/\text{m}^2 \cdot \text{K}$. Using the finite-difference method with a space increment of $\Delta x = 15 \text{ mm}$ and a time increment of 18 s, determine temperatures at the surface and at a depth of 45 mm after 3 min have elapsed.
- 5.76 Consider the fuel element of Example 5.6. Initially, the element is at a uniform temperature of 250°C with no heat generation. Suddenly, the element is inserted into the reactor core causing a uniform volumetric heat generation rate of $\dot{q} = 10^8 \text{ W}/\text{m}^3$. The surfaces are convectively cooled with $T_\infty = 250^\circ\text{C}$ and $h = 1100 \text{ W}/\text{m}^2 \cdot \text{K}$. Using the explicit method with a space increment of 2 mm, determine the temperature distribution 1.5 s after the element is inserted into the core.
- 5.77 A plane wall of thickness 100 mm with a uniform volumetric heat generation of $\dot{q} = 1.5 \times 10^6 \text{ W}/\text{m}^3$ is exposed to convection conditions of $T_\infty = 30^\circ\text{C}$ and $h = 1000 \text{ W}/\text{m}^2 \cdot \text{K}$ on both surfaces. The wall is maintained under steady-state conditions when, suddenly, the heat generation level (\dot{q}) is reduced to zero. The thermal diffusivity and thermal conductivity of the wall material are $1.6 \times 10^{-6} \text{ m}^2/\text{s}$ and $75 \text{ W}/\text{m} \cdot \text{K}$. A space increment of 10 mm is suggested.

LIBRARY U. OF I. URBANA-CHAMPAIGN

- (a) Estimate the midplane temperature 3 min after the generation has been switched off. 5.81
- (b) Plot on $T-x$ coordinates the temperature distribution obtained in part (a). Show also the initial and steady-state temperature distributions for the wall.
- 5.78 For the conditions described in Example 5.6, use the finite-difference method to estimate the temperature at the midplane ($x = 0$) 20 s after the power level has been changed from \dot{q}_1 to \dot{q}_2 . 5.82
- 5.79 A thin circular disk is subjected to induction heating from a coil, the effect of which is to provide a uniform heat generation within a ring section as shown. Convection occurs at the upper surface, while the lower surface is well insulated.

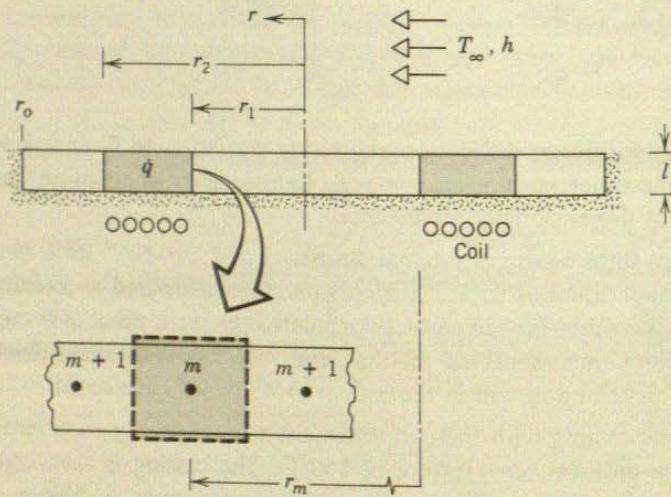

- (a) Derive the transient, finite-difference equation for node m , which is within the region subjected to induction heating.
- (b) On $T-r$ coordinates sketch, in a qualitative manner, the steady-state temperature distribution, identifying important features.
- 5.80 An electrical cable, experiencing a uniform volumetric generation \dot{q} , is half buried in an insulating material while the upper surface is exposed to a convection process (T_∞, h). 5.83

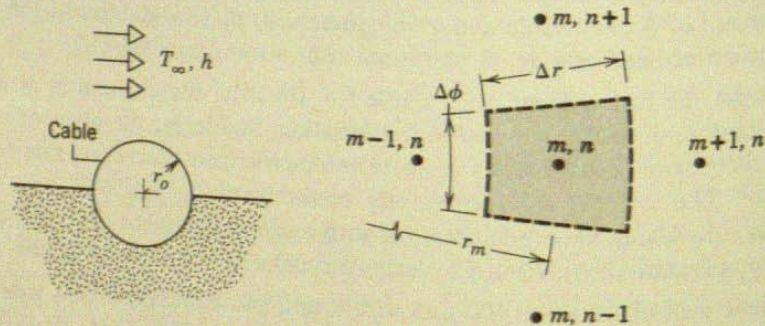

- (a) Derive the explicit, finite-difference equations for an interior node (m, n), the center node ($m = 0$), and the outer surface nodes (M, n) for the convection and insulated boundaries.
- (b) Obtain the stability criterion for each of the finite-difference equations. Identify the most restrictive criterion.

- 5.81 One end of a stainless steel (AISI 316) rod of diameter 10 mm and length 0.16 m is inserted into a fixture maintained at 200°C. The rod, covered with an insulating sleeve, reaches a uniform temperature throughout its length. When the sleeve is removed, the rod is subjected to ambient air at 25°C such that the convection heat transfer coefficient is 30 W/m² · K. Using a numerical technique, estimate the time required for the midlength of the rod to reach 100°C.
- 5.82 The cross section of an oven wall is composed of 30-mm-thick insulation sandwiched between two thin (1.5-mm-thick) stainless steel sheets. Under steady-state conditions, the oven is operating with an inside air temperature of $T_{\infty,i} = 150^\circ\text{C}$ and an ambient air temperature of $T_{\infty,o} = 20^\circ\text{C}$ with $h_i = 100 \text{ W/m}^2 \cdot \text{K}$ and $h_o = 10 \text{ W/m}^2 \cdot \text{K}$. When the oven heater level is changed and the fan speed changed to substantially increase air circulation within the oven, the inside surface of the oven experiences a sudden temperature change to 100°C. The insulation has a thermal conductivity of 0.03 W/m · K and a thermal diffusivity of $7.5 \times 10^{-7} \text{ m}^2/\text{s}$. In your finite-difference solution, use a space increment of 6 mm. Assume that the effect of the stainless steel sheets is negligible and that the outside convection heat transfer coefficient h_o remains unchanged. Estimate the time required for the oven wall to approximate steady-state conditions after the inner wall temperature is changed to 100°C.

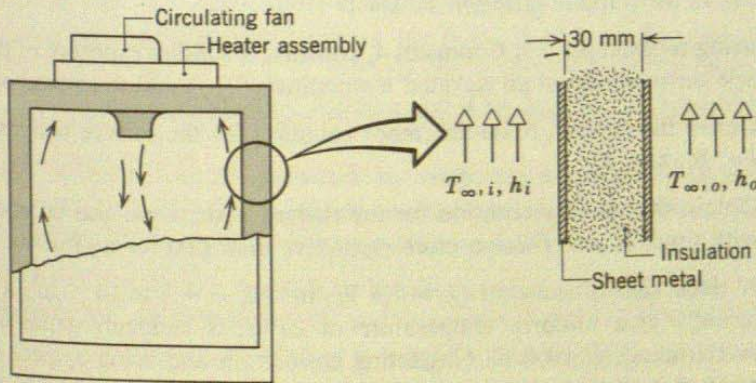

- 5.83 Two very long (in the direction normal to the page) bars having the prescribed initial temperature distributions are to be soldered together (see next page). At time $t = 0$, the $m = 3$ face of the copper (pure) bar contacts the $m = 4$ face of the steel (AISI 1010) bar. The solder and flux act as an interfacial layer of negligible thickness and effective contact resistance $R''_{t,c} = 2 \times 10^{-5} \text{ m}^2 \cdot \text{K/W}$.

Initial Temperatures (K)

n/m	1	2	3	4	5	6
1	700	700	700	1000	900	800
2	700	800	700	1000	900	800
3	700	700	700	1000	900	800

- (a) Derive the explicit, finite-difference equation in terms of Fo and $Bi_c = \Delta x/kR''_{t,c}$ for $T_{4,2}$ and determine the corresponding stability criterion.

LIBRARY U. OF I. URBANA-CHAMPAIGN

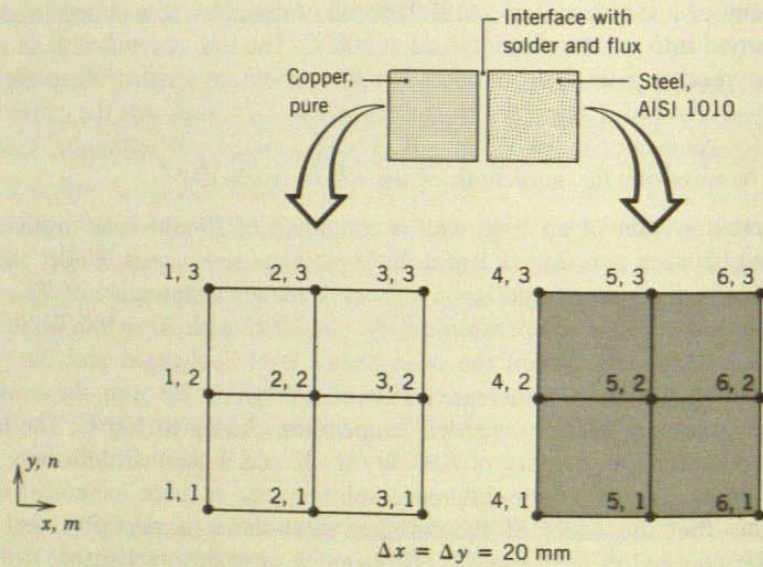

- (b) Using $Fo = 0.01$, determine $T_{4,2}$ one time step after contact is made. What is Δt ? Is the stability criterion satisfied?
- 5.84 Referring to Example 5.7, Comment 4, consider a sudden exposure of the surface to large surroundings at an elevated temperature (T_{sur}) and to convection (T_{∞}, h).
- Derive the explicit, finite-difference equation for the surface node in terms of Fo , Bi , and Bi_r .
 - Obtain the stability criterion for the surface node. Does this criterion change with time? Is the criterion more restrictive than that for an interior node?
 - A thick slab of material ($k = 1.5 \text{ W/m} \cdot \text{K}$, $\alpha = 7 \times 10^{-7} \text{ m}^2/\text{s}$, $\epsilon = 0.9$), initially at a uniform temperature of 27°C , is suddenly exposed to large surroundings at 1000 K . Neglecting convection and using a space increment of 10 mm , determine temperatures at the surface and 30 mm from the surface after an elapsed time of 1 min .
- 5.85 Consider the system of Problem 4.58. Initially with no flue gases flowing, the walls ($\alpha = 5.5 \times 10^{-6} \text{ m}^2/\text{s}$) are at a uniform temperature of 25°C . Using the implicit, finite-difference method with a time increment of 1 h , find the temperature distribution in the wall $1, 2, 5,$ and 20 h after introduction of the flue gases.
- 5.86 Consider the system of Problem 4.66. Initially, the ceramic plate ($\alpha = 1.5 \times 10^{-6} \text{ m}^2/\text{s}$) is at a uniform temperature of 30°C , and suddenly the electrical heating elements are energized. Using the implicit, finite-difference method, estimate the time required for the difference between the surface and initial temperatures to reach 95% of the difference for steady-state conditions. If you write a computer program, use a time increment of 2 s ; otherwise use 50 s .
- 5.87 Consider the bonding operation described in Problem 3.79, which was analyzed under steady-state conditions. In this case, however, the laser will be used to heat the film for a prescribed period of time, creating the transient heating situation shown in the sketch.

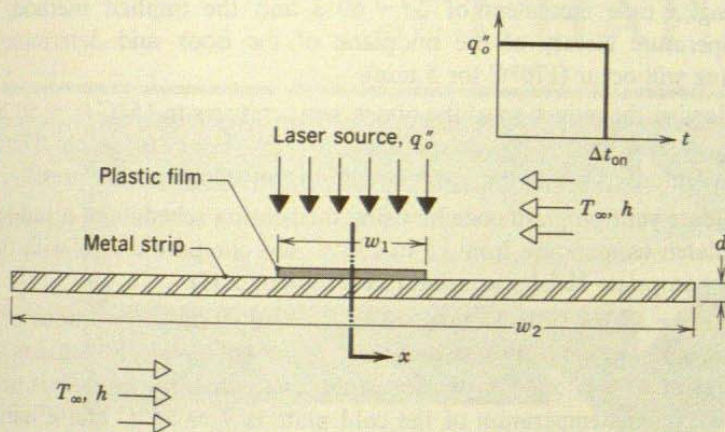

The strip is initially at 25°C and the laser provides a uniform flux of 85,000 W/m² over a time interval of $\Delta t_{on} = 10$ s. The system dimensions and thermo-physical properties remain the same, but the convection coefficient to the ambient air at 25°C is now 100 W/m² · K.

- (a) Using an implicit finite-difference method with $\Delta x = 4$ mm and $\Delta t = 1$ s, obtain temperature histories for $0 \leq t \leq 30$ s at the center and film edge, $T(0, t)$ and $T(w_1/2, t)$, respectively, to determine if the adhesive is satisfactorily cured above 90°C for 10 s and if its degradation temperature of 200°C is exceeded.
 - (b) Validate your program code by comparing it against the steady-state results of Problem 3.79. What type of analytical solution would you seek in order to test the proper transient behavior of your code?
- 5.88 Circuit boards are treated by heating a stack of them under high pressure as illustrated in Problem 5.32 and described further in Problem 5.33. A finite-difference method of solution is sought with two additional considerations. First, the book is to be treated as having distributed, rather than lumped characteristics, by using a grid spacing of $\Delta x = 2.36$ mm with nodes at the center of the individual circuit board or plate. Second, rather than bringing the platens to 190°C in one sudden change, the heating schedule $T_p(t)$ shown below is to be used in order to minimize excessive thermal stresses induced by rapidly changing thermal gradients in the vicinity of the platens.

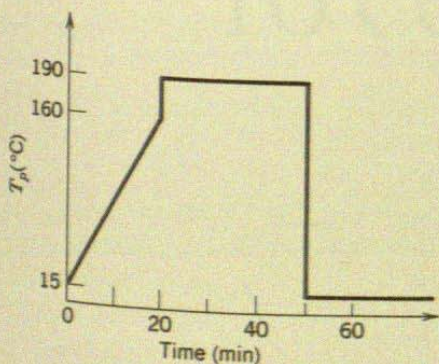

LIBRARY U. OF I. URBANA-CHAMPAIGN

- (a) Using a time increment of $\Delta t = 60$ s and the implicit method, find the temperature history of the midplane of the book and determine whether curing will occur (170°C for 5 min).
 - (b) Following the reduction of the platen temperatures to 15°C ($t = 50$ min), how long will it take for the midplane of the book to reach 37°C , a safe temperature at which the operator can begin unloading the press?
 - (c) Validate your program code by using the heating schedule of a sudden change of platen temperature from 15 to 190°C and compare results with those from an appropriate Heisler solution (see Problem 5.33).
- 5.89 Consider the thermal conduction module and operating conditions of Problem 4.71. To evaluate the transient response of the cold plate, which has a thermal diffusivity of $\alpha = 75 \times 10^{-6} \text{ m}^2/\text{s}$, assume that, when the module is activated at $t = 0$, the initial temperature of the cold plate is $T_i = 15^\circ\text{C}$ and a uniform heat flux of $q_o'' = 10^5 \text{ W/m}^2$ is applied at its base. Using the implicit finite-difference method and a time increment of $\Delta t = 0.1$ s, compute the designated nodal temperatures as a function of time. From the temperatures computed at a particular time, evaluate the ratio of the rate of heat transfer by convection to the water to the heat input at the base. Terminate the calculations when this ratio reaches 0.99. Print the temperature field at 5-s intervals and at the time for which the calculations are terminated.



Help Search History Titles Start Over

Public Catalog

Copyright Catalog (1978 to present)
Search Request: Left Anchored Title = fundamentals of heat and mass
Search Results: Displaying 7 of 8 entries

◀ previous next ▶

Labeled View

Fundamentals of heat and mass transfer / Frank P. Incropera, David P. DeWitt.

Type of Work: Text

Registration Number / Date: [TX0002807612 / 1990-05-14](#)

Title: Fundamentals of heat and mass transfer / Frank P. Incropera, David P. DeWitt.

Edition: 3rd ed.

Description: 1 v.

Copyright Claimant: John Wiley & Sons, Inc.

Date of Creation: 1989

Date of Publication: 1990-02-20

Previous Registration: Prev. reg. 1985, TX 1-590-503.

Basis of Claim: New Matter: compilation, additions, revisions.

Names: [Incropera, Frank P., 1939-](#)
[DeWitt, David P., 1934-](#)
[John Wiley & Sons, Inc.](#)

◀ previous next ▶

Save, Print and Email (Help Page)	
Select Download Format	Full Record <input type="button" value="Format for Print/Save"/>
Enter your email address:	<input type="text"/> <input type="button" value="Email"/>

[Help](#) [Search](#) [History](#) [Titles](#) [Start Over](#)



What happened to the Library Catalog?

Tell us what you think of the Library Catalog

Keyword Local Catalog Only Find

Login
Feedback

Advanced Search | Classic Search | Course Reserves | E-Reserves | Search History

< Back to Search Results Cite this Email this Add to favorites Staff view More Information Google Book Search

Fundamentals of heat and mass transfer /

Frank P. Incropera, David P. DeWitt.

Main Author: Incropera, Frank P.
Other Names: DeWitt, David P.
Published: New York : Wiley, c1990.
Edition: 3rd ed.
Topics: Mass transfer | Heat - Transmission
Tags: No Tags, Be the first to tag this record! Add

More Details	Location & Availability	Table of Contents	User Reviews	Published Reviews	Request Item
--------------	-------------------------	-------------------	--------------	-------------------	--------------

```

00000735nam a2200253 a 4500
0011652206
003UIUdb
00520020415162243.0
008890725s1990 nyua b 00110 eng
020|a0471612464
035|a(OCoLC)ocm20167416
035|9ANC-0675
040|aDLC|cDLC|dJFS
05000|aQC320|b.I45 1990
08200|a621.402/2|220
10010|aIncropera, Frank P.
24510|aFundamentals of heat and mass transfer /|cFrank P. Incropera, David P. DeWitt.
250|a3rd ed.
2600 |aNew York :|bWiley,|cc1990.
300|axvi, 919, [53] p. :|bill. ;|c24 cm.
504|aIncludes bibliographical references.
6500|aMass transfer
6500|aHeat|xTransmission
70010|aDeWitt, David P.,|d1934-

```

Keyword Local Catalog Only Find

Advanced Search | Classic Search | Course Reserves | E-Reserves | Search History



Vollanzeige des Titels

Anzeigeformat: [Standardformat](#) [Katalogkarte](#) [Zitierformat](#) [MARC](#)

FMT	BK
LDR	01373nam--2200361uu-4500
001	000601149
003	ETHICS
005	20121002103441.0
008	910906s1990----xxuu---[-----]00 eng d
010	a 89-38319
019	a DeWitt, David P. (1934-) / Library of Congress
020	a 0-471-61246-4
040	a EPF-BC b fre c ETH-BIB e ETHICS-ISBD
08200	a 621.4022
08200	a 621.402/2 2 20
08204	a 536.2 2 20
08204	a 621.4022076 b I5F8 1990 2 22
08204	a 621.402/2 2 20
08214	a 621.402 2 19
0821	a 536.2 2 22
090	a 000654470 b BHR n 0
090	a G144795 b GLIS
090	a HCI004649806 b EBI03
099	a WUIL c 19960521 E01 h 16:34:16
245	a Fundamentals of heat and mass transfer c Frank P. Incropera, David P. DeWitt
250	a Third ed.
260	a New York [etc.] b Wiley c cop. 1990
300	a 1 vol. (pag. mult.) c 25 cm b ill.
500	a andere Ausgabe: Fundamentals of heat and mass transfer
691E1	a WÄRMEÜBERGANG 9 ger 8 536.24
691E1	a THEORIE DES WÄRMEÜBERGANGS 9 ger 8 536.24.01
691E1	a WÄRMETRANSPORT (WÄRMELEHRE) 9 ger 8 536.2
691E1	a KONVEKTION (WÄRMELEHRE) 9 ger 8 536.25
691E1	a WÄRMEAUSTAUSCHER/GLEICH- UND GEGENSTROM-WÄRMEAUSTAUSCHER 9 ger 8 536.27
691E1	a WÄRMESTRAHLUNG (WÄRMELEHRE) 9 ger 8 536.3
691E1	a STOFFÜBERTRAGUNG (PHYSIKALISCHE CHEMIE) 9 ger 8 541.12*1
650Z	a Masse (Physik)
650Z	a Transportprozess
650Z	a Wärmeleitung
655Z	a Lehrbuch [Formschlagwort]
650 7	a Stoffübergang 1 (DE-588)4183410-0 2 gnd
650 7	a Stoffübertragung 1 (DE-588)4057696-6 2 gnd
650 7	a Wärmeübergang 1 (DE-588)4188877-7 2 gnd
650 7	a Wärmeübertragung 1 (DE-588)4064211-2 2 gnd
650 0	a Heat x Transmission
650 0	a Mass transfer
700	a DeWitt, David P.
7001	a Incropera, Frank P. 1 (DE-588)1089301553
940	a EM000005833807 c BOOK d 11 f E92 g E92LA j Dd - 4 : 90
CAT	a CONV b 00 c 19990819 EBI01 h 1114
CAT	c 20000930 EBI01 h 0351
CAT	c 20010915 EBI01 h 0438
CAT	a E01-WAHO b 20 c 20011221 EBI01 h 1145
CAT	a E02-FRSC b 20 c 20021016 EBI01 h 1621
CAT	c 20021104 EBI01 h 1805
CAT	a BATCH-UPD b 00 c 20040223 EBI01 h 2109
CAT	a E01-OLWE b 20 c 20040528 EBI01 h 1009
CAT	a BATCH-UPD b 20 c 20041116 EBI01 h 2059
CAT	a E01-CLAR b 20 c 20050425 EBI01 h 1452
CAT	a BATCH-UPD b 20 c 20060618 EBI01 h 0107
CAT	a imp_940_92 b c 20060706 EBI01 h 1715
CAT	c 20060707 EBI01 h 0922
CAT	a imp_940_92 b c 20060707 EBI01 h 1102
CAT	a BATCH-UPD b 00 c 20070306 EBI01 h 1831
CAT	a BATCH-UPD b 00 c 20070823 EBI01 h 2028
CAT	a BATCH-UPD b 00 c 20090110 EBI01 h 0158
CAT	a BATCH-UPD b 00 c 20090128 EBI01 h 2042
CAT	c 20090217 EBI01 h 1700
CAT	c 20090217 EBI01 h 1716
CAT	a BATCH-UPD b 00 c 20090218 EBI01 h 0530
CAT	a E02T-ALBO b 20 c 20121002 EBI01 h 1034
CAT	a 6xx_KOR b c 20140201 EBI01 h 1013
CAT	a BATCH-UPD b 00 c 20160407 EBI01 h 0419
CAT	a REKAT15 b 20 c 20160729 EBI01 h 2215
PST4	0 Z30 1 000601149000010 b E01 c 01 o BOOK d 01 f N r EHO60-000000000 n 4 j 424815 3 Buch/Monografie 4 ETH-BIB (Zürich) 5 Magazin 6 Ausleihe 4 Wochen
PST4	0 Z30 1 000601149000150 b E02 c E02MG o BOOK e DS f N r EHO60-000000000 n 4 j Dd - 4 /1990 3 Buch/Monografie 4 EPF-BIB (Lausanne) 5 Sous-sol zone B2.2 7 ausgeschieden
PST4	0 Z30 1 000601149000140 b E33 o BOOK d 15 f N r EHO60-000000000 n 4 j 349 E (115091) 3 Buch/Monografie 4 ETH-HCI (Zürich) 6 Ausleihe 2 Wochen
PST4	0 Z30 1 000601149000100 b E62 o BOOK d 11 f N r EHO60-000000000 n 4 j 15926 3 Buch/Monografie 4 HES-HEIG-VD (Yverdon) 6 Ausleihe 4 Wochen
PST4	0 Z30 1 000601149000130 b E62 o BOOK d 11 f N r EHO60-000000000 n 4 j 23627 3 Buch/Monografie 4 HES-HEIG-VD (Yverdon) 6 Ausleihe 4 Wochen
PST4	0 Z30 1 000601149000100 b E62 o BOOK d 11 f N r EHO60-000000000 n 4 j 536.2 INCR 3 Buch/Monografie 4 HES-HEIG-VD (Yverdon) 6 Ausleihe 4 Wochen

Attachment 1f: École Polytechnique Fédérale de Lausanne (EPFL) Library catalog record, in MARC format, for Incropera

PS 14	0 Z30 1 000601149000090 b E63 o BOOK d 11 f N r EHO60-000000000 n 4 j 536.2 INC/ed.3 3 Buch/Monografie 4 HES-HEVS-1 (Sion) 6 Ausleihe 4 wochen
PST4	0 Z30 1 000601149000120 b E68 o BOOK d 51 f N r EHO60-000000000 n 4 j 536 INCRO 3 Buch/Monografie 4 HES-EIARC-NE (Neuchâtel) 6 nur intern (1 Jahr)
PST4	0 Z30 1 000601149000120 b E68 o BOOK d 51 f N r EHO60-000000000 n 4 j 973.03 3 Buch/Monografie 4 HES-EIARC-NE (Neuchâtel) 6 nur intern (1 Jahr)
PST4	0 Z30 1 000601149000070 b Z01 c 03 o BOOK d 11 f N r EHO60-000000000 n 4 j GS 5026 3 Buch 4 ZB (Zürich) 5 Freihand 03 - frei zugänglich, 3.UG 6 Ausleihe 4 Wochen
SBL	a E01
SBL	a E02
SBL	a E33
SBL	a E62
SBL	a E63
SBL	a E68
SBL	a Z01
LOC4	b E01 c 01 j 424815 o BOOK
LOC4	b E02 c E02MG j Dd - 4 /1990 o BOOK
LOC4	b E33 j 349 E (115091) o BOOK
LOC4	b E62 j 15926 o BOOK
LOC4	b E62 j 23627 o BOOK
LOC4	b E62 j 536.2 INCR o BOOK
LOC4	b E63 j 536.2 INC/ed.3 o BOOK
LOC4	b E68 j 536 INCRO o BOOK
LOC4	b E68 j 973.03 o BOOK
LOC4	b Z01 c 03 j GS 5026 o BOOK
STS	a 01
STS	a 15
STS	a 11
STS	a 51
691E1	a HEAT TRANSFER 9 eng 8 536.24
691E1	a TRANSFERT DE CHALEUR 9 fre 8 536.24
691E1	a THÉORIE DU TRANSFERT DE CHALEUR 9 fre 8 536.24.01
691E1	a THEORY OF HEAT TRANSFER 9 eng 8 536.24.01
691E1	a HEAT TRANSPORT (THERMOPHYSICS) 9 eng 8 536.2
691E1	a TRANSPORT DE LA CHALEUR (CHALEUR) 9 fre 8 536.2
691E1	a CONVECTION (THERMOPHYSICS) 9 eng 8 536.25
691E1	a CONVECTION (CHALEUR) 9 fre 8 536.25
691E1	a HEAT EXCHANGERS/DIRECT FLOW AND COUNTER-FLOW 9 eng 8 536.27
691E1	a ÉCHANGEURS DE CHALEUR À COURANTS PARALLELES ET À COURANTS INVERSEES 9 fre 8 536.27
691E1	a HEAT RADIATION (THERMOPHYSICS) 9 eng 8 536.3
691E1	a RAYONNEMENT THERMIQUE (CHALEUR) 9 fre 8 536.3
691E1	a TRANSFERT DE MASSE (CHIMIE PHYSIQUE) 9 fre 8 541.12*1
691E1	a MASS TRANSFER (PHYSICAL CHEMISTRY) 9 eng 8 541.12*1
SYS	000601149

Bestellen:

- Klicken Sie auf *Alle Exemplare* oder den Namen der Bibliothek (rechte Spalte), um zu Exemplaren zu kommen und ggf. zu bestellen.
- Bei Reihen/Serien klicken Sie auf *Bandübersicht* oder *Ergebnisliste der Bände/Teile erstellen*, um zu den einzelnen Bänden zu kommen.
- Bei Zeitschriften können Sie auch den Bestand eines Jahres auswählen.

Klicken Sie auf einen unterstrichenen Begriff in der Titelanzeige, um zu den Suchdiensten zu gelangen.
 Klicken Sie auf *[i]*, um die Bibliotheksinfo zu sehen.

Feedback/Anregungen - FAQ



Search	Alerts	Lists	My Scopus
--------	--------	-------	-----------

REF ((1990) fundamentals of heat AND mass transfer) AND PUBYEAR < 1996 Edit Save Set alert Set feed

92 document results

View secondary documents | View 16531108 patent results | Analyze search results

Sort on: Date Cited by Date (Oldest) ...

Search within results...

All Text export Download View citation overview View Cited by Add to List More...

Show all abstracts

Refine					
Year	<input type="checkbox"/> Simultaneous measurements of thickness and temperature profile in a wavy liquid film falling freely on a heating wall	Lyu, T.-H., Mudawar, I.	1991	Experimental Heat Transfer	5
<input type="radio"/> 1995 (39)	Di cover full text View at Publisher				
<input type="radio"/> 1994 (23)	<input type="checkbox"/> Estimation of dissolved carbon dioxide concentrations in aerobic fermentations	Royce, P.N.C., Thornhill, N.F.	1991	AIChE Journal	60
<input type="radio"/> 1993 (17)	Di cover full text View at Publisher				
<input type="radio"/> 1992 (11)	<input type="checkbox"/> On the Action of Wetting Agents in the Extinction of Wood Fires	Jones, J.C., Hughes, K.C., Wearing, H.	1992	Journal of Fire Sciences	1
<input type="radio"/> 1991 (2)	Di cover full text View at Publisher				
Author Name	<input type="checkbox"/> Determination of thermal conductivity and diffusivity by transient heating of a thin slab	Tan, S.-A., Low, B.-H., Fwa, T.-F.	1992	Building and Environment	8
<input type="checkbox"/> Bejan, A. (4)	Di cover full text View at Publisher				
<input type="checkbox"/> Fwa, T.F. (3)	<input type="checkbox"/> Influence of pavement materials on the thermal environment of outdoor spaces	Tan, S.-A., Fwa, T.-F.	1992	Building and Environment	26
<input type="checkbox"/> Naterer, G.F. (3)	Di cover full text View at Publisher				
<input type="checkbox"/> Tan, S.A. (3)	<input type="checkbox"/> Heat Sink Optimization with Application to Microchannels	Knight, R.W., Goodling, J.S., Hall, D.J., Jaeger, R.C.	1992	IEEE Transactions on Components, Hybrids, and Manufacturing Technology 15 (5), pp. 832-842	290 Cited by
<input type="checkbox"/> Akyurt, M. (2)	Di cover full text View at Publisher				
<input type="checkbox"/> Goodling, J.S. (2)	<input type="checkbox"/> Two-Dimensional effects and design criteria for convective extended surfaces	Razelos, P., Georgiou, E.	1992	Heat Transfer Engineering 13 (3), pp. 38-48	42 Cited by
<input type="checkbox"/> Goudie, N.J. (2)	Di cover full text View at Publisher				
<input type="checkbox"/> Hubin, A. (2)	<input type="checkbox"/> Optimal Thermal Design of Air Cooled Forced Convection Finned Heat Sinks — Experimental Verification	Knight, R.W., Goodling, J.S., Gross, B.E.	1992	IEEE Transactions on Components, Hybrids, and Manufacturing Technology	34
<input type="checkbox"/> Kim, S.J. (2)	Di cover full text View at Publisher				
<input type="checkbox"/> Knight, R.W. (2)	<input type="checkbox"/> Prandtl number effects on laminar mixed convection heat transfer in a lid-driven cavity	Moallemi, M.K., Jang, K.S.	1992	International Journal of Heat and Mass Transfer	126
Subject Area	Di cover full text View at Publisher				
<input type="checkbox"/> Engineering (59)	<input type="checkbox"/> Evaluation of metal hydride compressors for applications in Joule-Thomson cryocoolers	Bowman Jr, R.C., Freeman, B.D., Phillips, J.R.	1992	Cryogenics	8
<input type="checkbox"/> Chemical Engineering (36)	Di cover full text View at Publisher				
<input type="checkbox"/> Physics and Astronomy (32)	<input type="checkbox"/> Film and transition boiling correlations for quenching of hot surfaces with water sprays	Klinzing, W.P., Rozzi, J.C., Mudawar, I.	1992	Journal of Heat Treating	40
<input type="checkbox"/> Energy (28)	Di cover full text View at Publisher				
<input type="checkbox"/> Materials Science (21)	<input type="checkbox"/> Dynamic optical property changes: Implications for reflectance feedback control of photocagulation	Jerath, M.R., Gardner, C.M., Rylander III, H.G., Welch, A.J.	1992	Journal of Photochemistry and Photobiology, B: Biology	26
Document Type	Di cover full text View at Publisher				
<input type="checkbox"/> Article (87)	<input type="checkbox"/> Analysis of heat and mass transfer to determine heat loss and the rate of condensation of the MVSTs off-gas ducts	Ebadian, M.A., Yang, G., Bigzadeh, E., Walker, J.F., Abraham, T.J.	1992	Nuclear Engineering and Design	0
<input type="checkbox"/> Conference Paper (4)	Di cover full text View at Publisher				
<input type="checkbox"/> Review (1)	<input type="checkbox"/> How to distribute a finite amount of insulation on a wall with nonuniform temperature	Bejan, A.	1993	International Journal of Heat and Mass Transfer 36 (1), pp. 49-56	21 Cited by
Source Title	Di cover full text View at Publisher				
<input type="checkbox"/> International Journal Of Heat And Mass Transfer (13)	<input type="checkbox"/> Modelling of the one-sided infra-red heating of polyurethane	Menezes, M., Watt, D.F.	1993	Journal of Plastic Film & Sheeting	3
<input type="checkbox"/> International Communications In Heat And Mass Transfer (4)	Di cover full text View at Publisher				
<input type="checkbox"/> International Journal Of Heat And Fluid Flow (4)	<input type="checkbox"/> Asymptotic analysis of the lumped-capacitance approximation	Shaw, B.D.	1993	International Journal of Heat and Mass Transfer	1
<input type="checkbox"/> Building And Environment (3)	Di cover full text View at Publisher				
<input type="checkbox"/> Canadian Metallurgical Quarterly (3)	<input type="checkbox"/> Heat-transfer effectivenesses of shrouded, rectangular-fin arrays	Baus-Haq, R.F., Probert, S.D., Taylor, C.R.	1993	Applied Energy	5
<input type="checkbox"/> Numerical Heat Transfer Part B Fundamentals (3)	Di cover full text View at Publisher				
<input type="checkbox"/> 30th Thermophysics Conference (2)	<input type="checkbox"/> The cooling of a heat-generating board inside a parallel-plate channel	Bejan, A., Morega, A.I.M., Lee, S.W., Kim, S.J.	1993	International Journal of Heat and Fluid Flow	5
<input type="checkbox"/> Applied Energy (2)	Di cover full text View at Publisher				
<input type="checkbox"/> Experimental Heat Transfer (2)	<input type="checkbox"/> A liquid velocity sensor based on the hot-wire principle	van der Wiel, A.J., Linder, C., de Rooij, N.F., Bezinge, A.	1993	Sensors and Actuators: A. Physical	25
<input type="checkbox"/> Heat Recovery Systems And Chp (2)	Di cover full text View at Publisher				
Keyword	<input type="checkbox"/> Experimental investigation on convective heat transfer of heated spinning sphere	Tieng, S.M., Yan, A.C.	1993	International Journal of Heat and Mass	9
Affiliation	Di cover full text View at Publisher				
Country/Territory					
Source Type					
Language					

Export refine

Di cover full text View at Publisher				
<input type="checkbox"/> Thermal resistance of 1.3 μ m InGaAsP vertical cavity lasers 21	Shimizu, M., Babić, D.I., Dudley, J.J., Jiang, W.B., Bowers, J.E.	1993	Microwave and Optical Technology Letters	4
Di cover full text View at Publisher				
<input type="checkbox"/> Study of the heat transfer behavior of a latent heat thermal energy storage unit with a 22 finned tube	Lacroix, M.	1993	International Journal of Heat and Mass Transfer	127
Di cover full text View at Publisher				
<input type="checkbox"/> Numerical study of laminar heat transfer with temperature dependent fluid viscosity in a 23 2:1 rectangular duct	Sehyun, S., Cho, Y.I., Gringrich, W.K., Shyy, W.	1993	International Journal of Heat and Mass Transfer	31
Di cover full text View at Publisher				
<input type="checkbox"/> Unsteady flow and heat transfer for cylinder pairs in a channel 24	Tatsutani, K., Devarakonda, R., Humphrey, J.A.C.	1993	International Journal of Heat and Mass Transfer	55
Di cover full text View at Publisher				
<input type="checkbox"/> Estimation of thermophysical properties of a film coated on a substrate using pulsed 25 transient analysis	Kim, S.W., Taylor, R.E.	1993	International Journal of Thermophysics	6
Di cover full text View at Publisher				
<input type="checkbox"/> Numerical modeling of two-dimensional smoldering processes 26	Moallemi, M.K., Zhang, H., Kumar, S.	1993	Combustion and Flame 95 (1-2), pp. 170-182	25 Cited by
Di cover full text View at Publisher Show abstract Related documents				
<input type="checkbox"/> Measurement of the temperature and cure dependence of the thermal conductivity of 27 epoxy resin	Chern, B.-C., Moon, T.J., Howell, J.R.	1993	Experimental Heat Transfer	4
Di cover full text View at Publisher				
<input type="checkbox"/> Removal of reactive gases at indoor surfaces: Combining mass transport and surface 28 kinetics	Cano-Ruiz, J.A., Kong, D., Balas, R.B., Nazaroff, W.W.	1993	Atmospheric Environment Part A, General Topics	99
Di cover full text View at Publisher				
<input type="checkbox"/> Thermal characterization of thin films by photothermally induced laser beam deflection 29	Machlab, H., McGahan, W.A., Wooliam, J.A., Cole, K.	1993	Thin Solid Films	11
Di cover full text View at Publisher				
<input type="checkbox"/> Temperature distribution in thermoluminescence experiments. II: Some calculations 30 models	Betts, D.S., Townsend, P.D.	1993	Journal of Physics D: Applied Physics	48
Di cover full text View at Publisher				
<input type="checkbox"/> Prediction of safe tip temperatures in uniform annular fins for the design of thermal 31 exchange equipment via symbolic mathematics	Campo, A., Harrison, L.	1994	International Communications in Heat and Mass Transfer	5
Di cover full text View at Publisher				
<input type="checkbox"/> A simple method to enhance thermal conductivity of charcoal using some additives 32	Eltom, O.M.M., Sayigh, A.A.M.	1994	Renewable Energy	9
Di cover full text View at Publisher				
<input type="checkbox"/> Simulation of packaged solar heat-pump water heaters 33	Morrison, G.L.	1994	Solar Energy	25
Di cover full text View at Publisher				
<input type="checkbox"/> Correlation of optimal sizes of bodies with external forced convection heat transfer 34	Fowler, A.J., Bejan, A.	1994	International Communications in Heat and Mass Transfer 21 (1), pp. 17-27	16 Cited by
Di cover full text View at Publisher Show abstract Related documents				
<input type="checkbox"/> Thermophysical relationships for waste heat recovery using looped heat pipes 35	Lamfon, N.J., Akyurt, M., Najjar, Y.S.H., Al-Rabghi, O.M.	1994	International Journal of Energy Research	7
Di cover full text View at Publisher				
<input type="checkbox"/> Thermal entrance length and Nusselt numbers in coiled tubes 36	Acharya, N., Sen, M., Hsueh-Chia, C.	1994	International Journal of Heat and Mass Transfer	18
Di cover full text View at Publisher				
<input type="checkbox"/> Design and eliminating the buoyancy effect of a heated circular jet 37	Chua, L.P., Goh, E.Y.	1994	International Communications in Heat and Mass Transfer	4
Di cover full text View at Publisher				
<input type="checkbox"/> Numerical modeling of the steady-state two-phase closed thermosyphon 38	Zuo, Z.J., Gunnerson, F.S.	1994	International Journal of Heat and Mass Transfer	22
Di cover full text View at Publisher				
<input type="checkbox"/> Mathematical modelling and experimental measurements on the horizontal ohno 39 continuous casting process for pure tin	Chabchoub, F., Argyropoulos, S.A., Mostaghimi, J.	1994	Canadian Metallurgical Quarterly	11
Di cover full text View at Publisher				
<input type="checkbox"/> Thermal stresses during cooling of prismatic bodies 40	Bradshaw, S., Ritter, B.	1994	Chemical Engineering Science	4
Di cover full text View at Publisher				
<input type="checkbox"/> Laser lithotripsy: the non-destructive measurement of calculus-surface optical absorption 41 coefficients	Jiang, Z.X., King, T.A.	1994	Lasers in Medical Science	0
Di cover full text View at Publisher				
<input type="checkbox"/> Steady-state and transient ampacity of bus bar 42	Coneybeer, R.T., Black, W.Z., Bush, R.A.	1994	IEEE Transactions on Power Delivery 9 (4), pp. 1822-1829	24 Cited by

Di cover full text View at Publisher Show abstract Related documents				
<input type="checkbox"/> Fabrication and packaging of a resonant infrared sensor integrated in silicon 43	Cabuz, C., Shoji, S., Fukatsu, K., (...), Minami, K., Esashi, M.	1994	Sensors and Actuators: A. Physical	33
Di cover full text View at Publisher				
<input type="checkbox"/> Thermomechanical simulation of a radial forging process 44	Tseng, A.A., Tong, S.X., Chen, T.C., Hashemi, J.	1994	Materials and Design	2
Di cover full text View at Publisher				
<input type="checkbox"/> An extended power law model for the calibration of hot-wire/hot-film constant temperature 45 probes	Wu, S., Bose, N.	1994	International Journal of Heat and Mass Transfer	5
Di cover full text View at Publisher				
<input type="checkbox"/> The effects of supercooling and freezing on natural convection in seawater 46	Brewster, R.A., Gebhart, B.	1994	International Journal of Heat and Mass Transfer	9
Di cover full text View at Publisher				
<input type="checkbox"/> Assessment of turbulence models for natural convection in an enclosure 47	Heindel, T.J., Ramadhyani, S., Incropera, F.P.	1994	Numerical Heat Transfer, Part B: Fundamentals 26 (2), pp. 147-172	26 Cited by
Di cover full text View at Publisher				
<input type="checkbox"/> Spray pyrolysis of YBCO precursors 48	Grader, G.S., Machado, D.R., Semiat, R.	1994	Journal of Materials Research	6
Di cover full text View at Publisher				
<input type="checkbox"/> Feasibility of the use of a Time-Temperature Integrator and a mathematical model to determine fluid-to-particle heat transfer coefficients 49	Maesmans, G.J., Hendrickx, M.E., De Cordt, S.V., Tobback, P.	1994	Food Research International	7
Di cover full text View at Publisher				
<input type="checkbox"/> Modeling the effect of mulch optical properties and mulch-soil contact resistance on soil heating under plastic mulch culture 50	Ham, J.M., Kluitenberg, G.J.	1994	Agricultural and Forest Meteorology	30
Di cover full text View at Publisher				
<input type="checkbox"/> Finite Element Computation of Field, Forces and Inductances in Underground SF6 Insulated Cables Using a Coupled Magneto-Thermal Formulation 51	Labridis, D., Hatzithanassiou, V.	1994	IEEE Transactions on Magnetics	31
Di cover full text View at Publisher				
<input type="checkbox"/> Copper-niobium and copper-tungsten composites as plasma torch cathodes 52	Szente, R.N., Munz, R.J., Drouet, M.G.	1994	Journal of Physics D: Applied Physics 27 (7), pp. 1443-1447	8 Cited by
Di cover full text View at Publisher Show abstract Related documents				
<input type="checkbox"/> The numerical solution of a non-linear boundary integral equation on smooth surfaces 53	Atkinson, K.E.	1994	IMA Journal of Numerical Analysis	19
Di cover full text View at Publisher				
<input type="checkbox"/> Transformer cooler performance: analysis and experiment 54	Lang, S.K., Bergles, A.E.	1995	Heat Transfer Engineering	0
Di cover full text View at Publisher				
<input type="checkbox"/> Heat transfers and pressure drops in rotating helical pipes 55	Yildiz, C., Biçer, Y., Pehlivan, D.	1995	Applied Energy	14
Di cover full text View at Publisher				
<input type="checkbox"/> The rate of drying of moisture from a metal surface and its implication for time of wetness 56	Cole, I.S., Holgate, R., Kao, P., Ganther, W.	1995	Corrosion Science	29
Di cover full text View at Publisher				
<input type="checkbox"/> Mixed convection in horizontal channels with discrete material and top exhaust 57	Bergman, T.L., Son, Y.S.	1995	International Journal of Heat and Mass Transfer	4
Di cover full text View at Publisher				
<input type="checkbox"/> Data reduction for k and α from transient heating of slab 58	Tan, S.-A., Low, B.-H., Fwa, T.-F.	1995	Building and Environment	0
Di cover full text View at Publisher				
<input type="checkbox"/> A Mathematical Model of a Solid Oxide Fuel Cell 59	Bessette, N.F., Wepfer, W.J., Winnick, J.	1995	Journal of the Electrochemical Society	135
Di cover full text View at Publisher				
<input type="checkbox"/> Design, construction and testing of a thermosiphon heat exchanger for medium temperature heat recovery in bakeries 60	Lukitobudi, A.R., Akbarzadeh, A., Johnson, P.W., Hendy, P.	1995	Heat Recovery Systems and CHP 15 (5), pp. 481-491	19 Cited by
Di cover full text View at Publisher Show abstract Related documents				
<input type="checkbox"/> Computer simulation of a combined cycle power plant 61	Seyedan, B., Dhar, P.L., Gaur, R.R., Bindra, G.S.	1995	Heat Recovery Systems and CHP	4
Di cover full text View at Publisher				
<input type="checkbox"/> Electrode Surface Control of the Transition from Micro-Arcs to High-Current Arcs in Atmospheric-Pressure Plasmas 62	Kumar, A.S., Okazaki, K.	1995	IEEE Transactions on Plasma Science	1
Di cover full text View at Publisher				
<input type="checkbox"/> Total heat transfer coefficients for canned foods during sterilization 63	Dincer, I., Varlik, C., Gun, H.	1995	International Journal of Energy Research	2
Di cover full text View at Publisher				
<input type="checkbox"/> Spectral-directional emittance of fully oxidized copper 64	Jones, P.D., Dorai-Raj, D.E., McLeod, D.G.	1995	ASME/AIAA National Heat Transfer Conference	0
Di cover full text View at Publisher				
<input type="checkbox"/> Performance, Wireability, and Cooling Tradeoffs for Planar and 3-D Packaging 65	George, G., Krusius, J.P.	1995	IEEE Transactions on Components	6

65	Architectures			Packaging and Manufacturing Technology Part B 18 (2), pp. 339-345	Cited by
		Di cover full text View at Publisher Show abstract Related documents			
66	Experimental study of dynamic and thermal conditions during binary dendritic solidification	Naterer, G.F., Schneider, G.E.	1995	30th Thermophysics Conference	0
		Di cover full text			
67	The development of a sampling system for the determination of odor emission rates from areal surfaces: Part II. Mathematical model	Bliss, P.J., Jiang, K., Schulz, T.J.	1995	Journal of the Air and Waste Management Association	41
		Di cover full text View at Publisher			
68	Electrically heated tube investigation of cooling channel geometry effects	Meyer, M.L.	1995	31st Joint Propulsion Conference and Exhibit	0
		Di cover full text			
69	Thermal response of composite building envelopes accounting for thermal radiation	Price, B.A., Smith, T.F.	1995	Energy Conversion and Management	17
		Di cover full text View at Publisher			
70	Temperature variations in drying of sulfuric acid solutions in sand beds Part I: Temperature variations in the bed during the drying of water	Yapar, S., Helvacı, Ş.Ş., Peker, S.	1995	International Communications in Heat and Mass Transfer 22 (4), pp. 575-583	0 Cited by
		Di cover full text View at Publisher			
71	Synthesis of titanium carbide by self-propagating powder reactions. 1. Enthalpy of formation of TiC	Vrel, D.L., Lihmann, J.-M., Petitet, J.-P.	1995	Journal of Chemical and Engineering Data	15
		Di cover full text View at Publisher			
72	Thermal performance of a pin-fin assembly	Babus'Haq, R.F., Akintunde, K., Probert, S.D.	1995	International Journal of Heat and Fluid Flow	40
		Di cover full text View at Publisher			
73	Technique for the estimation of thermal resistance at solid metal interfaces formed during solidification and melting	Goudie, N.J., Argyropoulos, S.A.	1995	Canadian Metallurgical Quarterly 34 (1), pp. 73-84	15 Cited by
		Di cover full text View at Publisher Show abstract Related documents			
74	Technique for the estimation of thermal resistance at solid metal interfaces formed during solidification and melting	Goudie, N.J., Argyropoulos, S.A.	1995	Canadian Metallurgical Quarterly	0
		Di cover full text View at Publisher			
75	Cooling of stacks of plates shielded by porous screens	Bejan, A., Kim, S.J., Morega, A.M., Lee, S.W.	1995	International Journal of Heat and Fluid Flow	9
		Di cover full text View at Publisher			
76	Phases model for binary-constituent solid-liquid phase transition, part 1: Numerical method	Naterer, G.F., Schneider, G.E.	1995	Numerical Heat Transfer, Part B: Fundamentals	17
		Di cover full text View at Publisher			
77	Gas transport processes in human airways	Martonen, T.B., Zhang, Z., Yang, Y., Bottei, G.	1995	Inhalation Toxicology	9
		Di cover full text View at Publisher			
78	Interspecies modeling of inhaled gases	Martonen, T., Zhang, Z., Yang, Y.	1995	Inhalation Toxicology 7 (8), pp. 1125-1139	5 Cited by
		Di cover full text View at Publisher Show abstract Related documents			
79	Phases model for binary-constituent solid-liquid phase transition, part 2: Applications	Naterer, G.F., Schneider, G.E.	1995	Numerical Heat Transfer, Part B: Fundamentals	3
		Di cover full text View at Publisher			
80	Modeling of diffusion in capillary porous materials during the drying process	Dietl, C., George, O.P., Bansal, N.K.	1995	Drying Technology	10
		Di cover full text View at Publisher			
81	Interaction of a water mist with a buoyant methane diffusion flame	Downie, B., Polymeropoulos, C., Gogos, G.	1995	Fire Safety Journal	60
		Di cover full text View at Publisher			
82	Modeling of waste heat recovery by looped water-in-steel heat pipes	Akyurt, M., Lamfon, N.J., Najjar, Y.S.H., Habeebullah, M.H., Alp, T.Y.	1995	International Journal of Heat and Fluid Flow	18
		Di cover full text View at Publisher			
83	An experimental investigation into forced, natural and combined forced and natural convective heat transfer from stationary isothermal circular disks	Kobus, C.J., Wedekind, G.L.	1995	International Journal of Heat and Mass Transfer	23
		Di cover full text View at Publisher			
84	Investigation of the Thermal Behavior of a RTP Furnace	Henda, R., Scheid, E., Bielle-Daspel, D.	1995	IEEE Transactions on Semiconductor Manufacturing	2
		Di cover full text View at Publisher			
85	A solar-electric vehicle simulation code	Craparo, J.C., Thacher, E.F.	1995	Solar Energy 55 (3), pp. 221-234	11 Cited by
		Di cover full text View at Publisher Show abstract Related documents			
86	Thermal venting to recover less-volatile hydrocarbons from the unsaturated zone, 1. Theory	Kaluarachchi, J.J., Mesbah-Ul Islam, K.M.	1995	Journal of Contaminant Hydrology	8
		Di cover full text View at Publisher			
87	Shock initiation of crystalline boron in oxygen and fluorine compounds	Krier, H., Burton, R.L., Pirman, S.R., Snaidino, M.J.	1995	30th Thermophysics Conference	0

Di cover full text					
<input type="checkbox"/>	The viscous air flow pattern in the Stefan diffusion tube - Application to the mutual diffusion in a porous media	Benkhalifa, M., Arnaud, G., Fohr, J.-P.	1995	Transport in Porous Media	1
Di cover full text	View at Publisher				
<input type="checkbox"/>	A wall-jet electrode reactor and its application to the study of electrode reaction mechanisms Part II: A general computational method for the mass transport problems involved	Laevers, P., Hubin, A., Terryn, H., Vereecken, J.	1995	Journal of Applied Electrochemistry	13
Di cover full text	View at Publisher				
<input type="checkbox"/>	A wall-jet electrode reactor and its application to the study of electrode reaction mechanisms Part I: Design and construction	Laevers, P., Hubin, A., Terryn, H., Vereecken, J.	1995	Journal of Applied Electrochemistry	17
Di cover full text	View at Publisher				
<input type="checkbox"/>	Analytical scaling model for hydrocarbon emissions from fuel absorption in oil layers in spark ignition engines	Linna, J.R., Hochgreb, S.	1995	Combustion Science and Technology 109 (1-6), pp. 205-226	8 Cited by
Di cover full text	View at Publisher Show abstract Related documents				
<input type="checkbox"/>	Design and performance of a high-temperature, high-speed scanning tunneling microscope	Kuipers, L., Loos, R.W.M., Neerings, H., (...), De Jongh, A.P., Frenken, J.W.M.	1995	Review of Scientific Instruments	37
Di cover full text	View at Publisher				
Display	100 results per page			< Page 1 >	Top of page

[About Scopus](#)
[What is Scopus](#)
[Content coverage](#)
[Scopus Blog](#)
[Scopus API](#)
[Privacy Matters](#)

Language
[日本語に切り替える](#)
[切换到简体中文](#)
[切换到繁體中文](#)

Customer Service
[Help and Contact](#)
[Live Chat](#)

ELSEVIER

[Terms and Conditions](#) [Privacy policy](#)
 Copyright © 2016 Elsevier B.V. All rights reserved. Scopus® is a registered trademark of Elsevier B.V.
 Cookies are set by this site. To decline them or learn more, visit our [Cookies page](#)

RELX Group™

Search

Alerts

Lists

My Scopus

Your default export setting has been saved for this session. To save this setting across sessions, please sign in.

Your text export was opened in a new window. Please check your browser windows for further details.

Back to results | < Previous 35 of 1,148 Next >

Di cover full text | Di cover full text | View at Publisher | Text export | Download | Add to List | More...

Experimental Heat Transfer

Volume 4, Issue 3, July-September 1991, Pages 217-233

Simultaneous measurements of thickness and temperature profile in a wavy liquid film falling freely on a heating wall (Article)

Lyu, T.-H., Mudawar, I.

Purdue University, West Lafayette, IN, 47907, United States

Abstract

A technique for measuring the thickness of liquid films was developed and successfully tested. The feasibility of this technique was demonstrated in stagnant liquid films as well as in liquid jets. A procedure for in-situ calibration of the thickness probe was developed, allowing the adaptation of the probe to measurements of wavy liquid films. The thickness probe was constructed from a platinum-rhodium wire that was stretched across the film. A constant DC current was supplied through the probe wire, and film thickness was determined from variations in the probe voltage drop resulting from the large differences in the electrical resistances of the wetted and unwetted segments of the wire. Unlike electrical admittance thickness probes, the new probe did not require dissolving an electrolyte in the liquid, making the new probe well suited to studies involving sensible heating of a film of pure dielectric liquid that is in duvet contact with a current-carrying wall. Also presented is a composite probe that facilitated simultaneous measurements of temperature profile across a wavy liquid film and film thickness. Experimental results demonstrate a strong influence of waviness on liquid temperature in a film of deionized water falling freely on the outside wall of a vertical, electrically heated tube for film Reynolds numbers smaller than 10,000. © 1991 Taylor & Francis Group, LLC.

View references (14)

Indexed keywords

Engineering controlled terms: Films - Thickness Measurement; Liquids - Thin Films

Engineering uncontrolled terms: Electrical Admittance Thickness Probe; Falling Freely Liquid Films; Stagnant Liquid Films; Thickness Probe Dynamic Calibration; Wavy Liquid Film

Engineering main heading: Liquids

ISSN: 08916152 Source Type: Journal Original language: English

DOI: 10.1080/08916159108946415 Document Type: Article

References (14)

View in search results format

All | Text export | Print | E-mail | Create bibliography

- Hewitt, G.F.
1 Measurement of Film Thickness
(1982) *Handbook of Multiphase Systems*, p. 10. Cited 4 times.
G. Hetsroni (ed.), McGraw-Hill, New York, chap
- Miya, M., Woodmansee, D.E., Hanratty, T.J.
2 **A model for roll waves in gas-liquid flow**
(1971) *Chemical Engineering Science*, 26 (11), pp. 1915-1931. Cited 86 times.
doi: 10.1016/0009-2509(71)86034-7
[Di cover full text](#) | [View at Publisher](#)
- Brown, R.C., Andreussi, P., Zanelli, S.
3 **The use of wire probes for the measurement of liquid film thickness in annular gas-liquid flows**
(1978) *The Canadian Journal of Chemical Engineering*, 56 (6), pp. 754-757. Cited 59 times.
doi: 10.1002/cjce.5450560618
[Di cover full text](#) | [View at Publisher](#)
- Karapantsios, T.D., Paras, S.V., Karabelas, A.J.
4 **Statistical characteristics of free falling films at high reynolds numbers**
(1989) *International Journal of Multiphase Flow*, 15 (1), pp. 1-21. Cited 71 times.
doi: 10.1016/0301-9322(89)90082-7
[Di cover full text](#) | [View at Publisher](#)
- Koskie, J.E., Mudawar, I., Tiederman, W.G.
5 **Parallel-wire probes for measurement of thick liquid films**
(1989) *International Journal of Multiphase Flow*, 15 (4), pp. 521-530. Cited 66 times.
doi: 10.1016/0301-9322(89)90051-7
[Di cover full text](#) | [View at Publisher](#)
- Akai, M., Inoue, A., Aoki, S.
6 Structure of a Co-current Stratified Two-Phase Flow with Wavy Interface

Cited by 5 documents

Statistical analysis of measured and computed thickness and interfacial temperature of free-falling turbulent liquid films
Mascarenhas, N., Mudawar, I.
(2014) *International Journal of Heat and Mass Transfer*

Study of the influence of interfacial waves on heat transfer in turbulent falling films
Mascarenhas, N., Mudawar, I.
(2013) *International Journal of Heat and Mass Transfer*

Investigation of eddy diffusivity and heat transfer coefficient for free-falling turbulent liquid films subjected to sensible heating
Mascarenhas, N., Mudawar, I.
(2013) *International Journal of Heat and Mass Transfer*

View all 5 citing documents

Inform me when this document is cited in Scopus:

Set citation alert | Set citation feed

Related documents

The development of a flush-wire probe and calibration method for measuring liquid film thickness
Kang, H.C., Kim, M.H.
(1992) *International Journal of Multiphase Flow*

Statistical investigation of the relationship between interfacial waviness and sensible heat transfer to a falling liquid film
Lyu, T.H., Mudawar, I.
(1991) *International Journal of Heat and Mass Transfer*

Measurement of three-dimensional wave form and interfacial area in an air-water stratified flow
Kang, H.C., Kim, M.H.
(1992) *Nuclear Engineering and Design*

View all related documents based on references

Find more related documents in Scopus based on:

Authors | Keywords

Metrics

5 Citations 30TH PERCENTILE

View all metrics

- ~ (1977) *Theor. Appl. Mech.*, 25, pp. 445-456. Cited 6 times.

- Barry, J.J.
7 (1987) *Effects of Interfacial Structure on Film Condensation*. Cited 2 times.
Ph.D. thesis, University of Wisconsin-Madison

- Incropera, F.P., Dewitt, D.P.
8 (1990) *Fundamentals of Heat and Mass Transfer*, pp. 411-412. Cited 11473 times.
Wiley, New York

- Patankar, S.V.
9 **Numerical heat transfer and fluid flow.**
(1980) . Cited 18617 times.
ISBN: 0 07 048740 5
[Di cover full text](#)

- Shmerler, J.A., Mudawwar, I.
10 **Local heat transfer coefficient in wavy free-falling turbulent liquid films undergoing uniform sensible heating**
(1988) *International Journal of Heat and Mass Transfer*, 31 (1), pp. 67-77. Cited 48 times.
doi: 10.1016/0017-9310(88)90223-2
[Di cover full text](#) [View at Publisher](#)

- Gimbutis, G.
11 **HEAT TRANSFER OF A TURBULENT VERTICALLY FALLING FILM.**
(1974) , pp. 85-89. Cited 9 times.
[Di cover full text](#)

- Thkahoma, H., Kato, S.
12 *Int. J. Multiphase Flow*

- Portalski, S.
13 **Studies of falling liquid film flow Film thickness on a smooth vertical plate**
(1963) *Chemical Engineering Science*, 18 (12), pp. 787-804. Cited 36 times.
[Di cover full text](#) [View at Publisher](#)

- H. Lyu And, T.
14 Mudawar, Statistical Investigation of the Relationship Between Interfacial Waviness and Sensible Heat Transfer to a Falling Liquid Film
Int. J. Heat Mass Transfer

© Copyright 2016 Elsevier B.V., All rights reserved.

[Back to results](#) | [< Previous](#) 35 of 1,148 [Next >](#)

[Top of page](#) ^

[About Scopus](#)
[What is Scopus](#)
[Content coverage](#)
[Scopus Blog](#)
[Scopus API](#)
[Privacy Matters](#)

[Language](#)
 日本語に切り替える
[切换到简体中文](#)
[切换到繁體中文](#)

[Customer Service](#)
[Help and Contact](#)
[Live Chat](#)

ELSEVIER

[Terms and Conditions](#) [Privacy policy](#)
 Copyright © 2016 Elsevier B.V. All rights reserved. Scopus® is a registered trademark of Elsevier B.V.
 Cookies are set by this site. To decline them or learn more, visit our [Cookies page](#)

RELX Group™