



US006059576C1

(12) **EX PARTE REEXAMINATION CERTIFICATE** (10541st)
United States Patent
Brann

(10) **Number:** **US 6,059,576 C1**

(45) **Certificate Issued:** **Mar. 17, 2015**

(54) **TRAINING AND SAFETY DEVICE, SYSTEM AND METHOD TO AID IN PROPER MOVEMENT DURING PHYSICAL ACTIVITY**

90/013,201, please refer to the USPTO's public Patent Application Information Retrieval (PAIR) system under the Display References tab.

(75) Inventor: **Theodore L. Brann**, Mission, TX (US)

Primary Examiner — Danton DeMille

(73) Assignee: **Logantree L P**, Boerne, TX (US)

Reexamination Request:

No. 90/013,201, Apr. 4, 2014

(57) **ABSTRACT**

Reexamination Certificate for:

Patent No.: **6,059,576**
Issued: **May 9, 2000**
Appl. No.: **08/976,228**
Filed: **Nov. 21, 1997**

An electronic device, system and method to monitor and train an individual on proper motion during physical movement. The system employs an electronic device which tracks and monitors an individual's motion through the use of an accelerometer capable of measuring parameters associated with the individual's movement. The device also employs a user-programmable microprocessor which receives, interprets, stores and responds to data relating to the movement parameters based on customizable operation parameters, a real-time clock connected to the microprocessor, memory for storing the movement data, a power source, a port for downloading the data from the device to other computation or storage devices contained within the system, and various input and output components. The downloadable, self-contained device can be worn at various positions along the torso or appendages being monitored depending on the specific physical task being performed. The device also detects the speed of movements made while the device is being worn. When a preprogrammed recordable event is recognized, the device records the time and date of the occurrence while providing feedback to the wearer via visual, audible and/or tactile warnings.

(51) **Int. Cl.**
A61B 5/11 (2006.01)
A63B 24/00 (2006.01)

(52) **U.S. Cl.**
CPC *A61B 5/1116* (2013.01); *A63B 2220/40* (2013.01); *Y10S 482/901* (2013.01)
USPC *434/247*; *600/595*; *482/8*; *482/901*; *702/101*; *601/34*

(58) **Field of Classification Search**
None
See application file for complete search history.

(56) **References Cited**

To view the complete listing of prior art documents cited during the proceeding for Reexamination Control Number

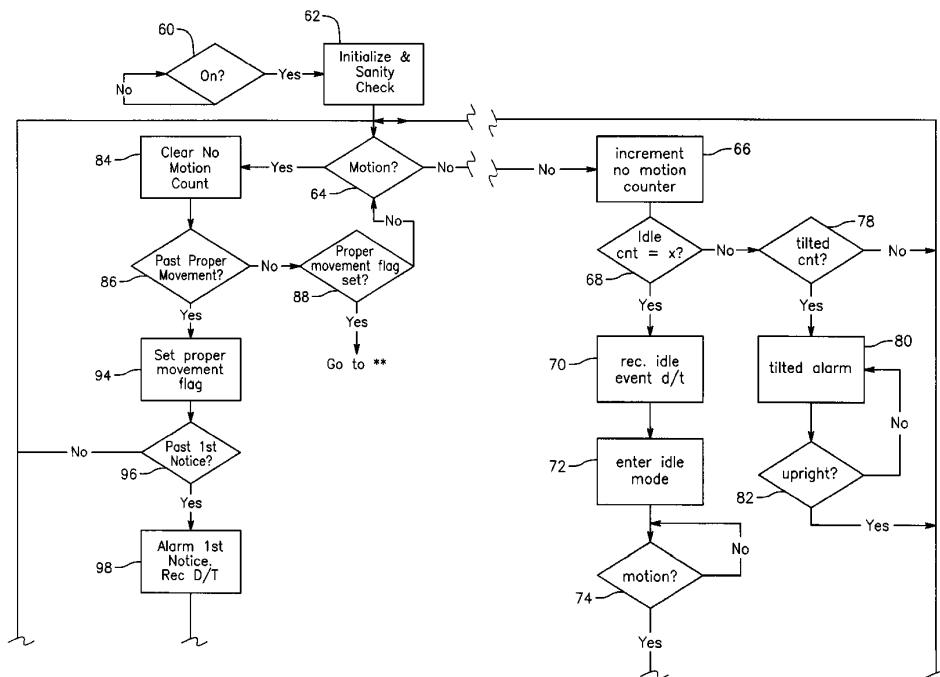

1
EX PARTE
REEXAMINATION CERTIFICATE
ISSUED UNDER 35 U.S.C. 307

THE PATENT IS HEREBY AMENDED AS
INDICATED BELOW.

Matter enclosed in heavy brackets [] appeared in the patent, but has been deleted and is no longer a part of the patent; matter printed in italics indicates additions made to the patent.

AS A RESULT OF REEXAMINATION, IT HAS BEEN DETERMINED THAT:

Claims **1, 13** and **20** are determined to be patentable as amended.

Claims **2-12, 14-19** and **21-29**, dependent on an amended claim, are determined to be patentable.

New claims **30-185** are added and determined to be patentable.

1. A portable, self-contained device for monitoring movement of body parts during physical activity, said device comprising:

a movement sensor capable of measuring data associated with unrestrained movement in any direction and generating signals indicative of said movement;

a power source;

a microprocessor connected to said movement sensor and to said power source, said microprocessor capable of receiving, interpreting, storing and responding to said movement data based on user-defined operational parameters, *detecting a first user-defined event based on the movement data and at least one of the user-defined operational parameters regarding the movement data, and storing first event information related to the detected first user-defined event along with first time stamp information reflecting a time at which the movement data causing the first user-defined event occurred;*

at least one user input connected to said microprocessor for controlling the operation of said device;

a real-time clock connected to said microprocessor; memory for storing said movement data; and

an output indicator connected to said microprocessor for signaling the occurrence of user-defined events; wherein said movement sensor measures the angle and velocity of said movement.

13. A system to aid in training and safety during physical activity, said system comprising

a portable, self-contained movement measuring device, said movement measuring device further comprising

a movement sensor capable of measuring data associated with unrestrained movement in any direction and generating signals indicative of said movement;

a power source;

a microprocessor connected to said power source, said microprocessor capable of receiving, interpreting, storing and responding to said movement data based on user-defined operational parameters, *detecting a first user-defined event based on the movement data and at least one of the user-defined operational parameters regarding the movement data, and storing first event information related to the detected first user-defined event along with first time stamp information*

2

mation reflecting a time at which the movement data causing the first user-defined event occurred;

at least one user input connected to said microprocessor for controlling the operation of said device;

a real-time clock connected to said microprocessor; memory for storing said movement data;

at least one input/output port connected to said microprocessor for downloading said data and uploading said operational parameters; and

an output indicator connected to said microprocessor; a computer running a program capable of interpreting and reporting said movement data based on said operational parameters; and

a download device electronically connected to said movement measuring device and said computer for transmitting said movement data and operational parameters between said movement measuring device and said computer for analysis, reporting and operation purposes; wherein said movement sensor measures the angle and velocity of said movement.

20. A method to monitor physical movement of a body part comprising the steps of:

attaching a portable, self-contained movement measuring device to said body part for measuring unrestrained movement in any direction;

measuring data associated with said physical movement; interpreting, *using a microprocessor included in the portable, self-contained movement measuring device,* said physical movement data based on user-defined operational parameters and a real-time clock; **[and]**

storing said data in memory;

detecting, using the microprocessor, a first user-defined event based on the movement data and at least one of the user-defined operational parameters regarding the movement data; and

storing, in said memory, first event information related to the detected first user-defined event along with first time stamp information reflecting a time at which the movement data causing the first user-defined event occurred.

30. The device of claim 1, wherein said microprocessor is configured to store, in said memory, date information associated with the first time stamp information.

31. The device of claim 1, wherein said microprocessor is configured to retrieve said first time stamp information from said real-time clock and associate the retrieved first time stamp information with said first user-defined event.

32. The device of claim 31, wherein said microprocessor is configured to retrieve said first time stamp information from said real-time clock based on the detection of the user-defined event.

33. The device of claim 1, wherein said memory is configured to continue to store said movement data in response to battery power being lost from said power source.

34. The device of claim 1, wherein said movement sensor is configured to continuously check for said movement.

35. The device of claim 34, wherein said microprocessor is configured to continuously interpret, based on the user-defined operational parameters, said movement data received from said movement sensor.

36. The device of claim 1, wherein said output indicator is configured to display information signaling the occurrence of the first user-defined event based on the detection of the first user-defined event.

3

37. The device of claim 36, wherein said output indicator is configured to display said information signaling the occurrence of the first user-defined event based on said first time stamp information.

38. The device of claim 1, wherein said output indicator is configured to display information signaling the occurrence of the first user-defined event based on the detection of the first user-defined event and the first time stamp information.

39. The device of claim 1, wherein said at least one of the user-defined operational parameters is a predetermined threshold, and said first user-defined event occurs when the movement data reaches the predetermined threshold.

40. The device of claim 39, wherein said output indicator is configured to display information signaling the occurrence of the first user-defined event when the movement data reaches the predetermined threshold.

41. The device of claim 39, wherein said memory is configured to store said first event information indicating that the predetermined threshold is met.

42. The device of claim 41, wherein said memory is configured to store the first time stamp information in association with said first event information.

43. The device of claim 1, wherein said output indicator is configured to indicate a low battery condition of the device.

44. The device of claim 9, wherein said output indicator is selected from the group consisting of single monochromatic LEDs, multiple colored lights, and liquid crystal displays.

45. The device of claim 1, wherein said movement data stored in the memory is configured to be downloaded to a computer.

46. The device of claim 45, further comprising:

software configured to communicate with external software, wherein the external software is configured to present the downloaded movement data to the user.

47. The device of claim 46, wherein said external software is configured to run on the computer.

48. The device of claim 47, wherein said downloaded movement data is configured to be analyzed by said user via said external software.

49. The device of claim 46, wherein said external software is configured to interpret said movement data and produce at least one report.

50. The device of claim 46, wherein said external software is configured to interpret said movement data and produce at least one history report.

51. The device of claim 50, wherein said at least one history report includes dates and times of said movement data.

52. The device of claim 46, wherein said external software is configured to allow the user to program additional reports and histories with respect to said movement data of said user.

53. The device of claim 45, wherein said movement data is configured to be downloaded to said computer via a wired connection.

54. The device of claim 45, wherein said movement data is configured to be downloaded to said computer via a wireless connection.

55. The device of claim 39, wherein the output indicator is configured to provide a visual indicator to the user regarding the predetermined threshold being reached.

56. The device of claim 1, wherein the memory is configured to store the user-defined operational parameters, the user-defined operational parameters comprising a plurality of thresholds respectively corresponding to a plurality of notifications, wherein each time the movement data reaches one of the plurality of the thresholds, the microprocessor is configured to detect that one of the user-defined events occurred.

4

57. The device of claim 56, wherein when the microprocessor detects that one of the user-defined events occurred based on the movement data reaching one of the plurality of the thresholds, the output indicator displays a corresponding one of the notifications indicating that one of the user-defined events has occurred.

58. The device of claim 56, wherein the plurality of thresholds are different from each other.

59. The device of claim 56, wherein the plurality of notifications are different visual indicators.

60. The device of claim 59, wherein at least one of the visual indicators includes a blinking indicator.

61. The device of claim 39, wherein said microprocessor is configured to detect occurrence of the first user-defined event by comparing said movement data to said predetermined threshold.

62. The device of claim 1, wherein said device is configured to be placed on said user's arm to monitor and record said movement data.

63. The device of claim 62, wherein said movement sensor is configured to measure movement of said user's arm.

64. The device of claim 1, wherein said movement sensor is configured to measure a walking distance.

65. The device of claim 64, wherein said device is configured to be wearable by the user, and said movement sensor is configured to measure said walking distance of said user.

66. The device of claim 1, wherein said microprocessor is configured to store, in said memory, date information associated with the first time stamp information,

wherein said movement sensor is configured to continuously check for said movement,

wherein said output indicator is configured to display information signaling the occurrence of the first user-defined event based on the detection of the first user-defined event and the first time stamp information,

wherein the device further comprises software configured to communicate with external software configured to run on a computer and present the downloaded movement data,

wherein said external software is configured to produce at least one report based on said movement data,

wherein the memory is configured to store the user-defined operational parameters, the user-defined operational parameters comprising a plurality of thresholds respectively corresponding to a plurality of notifications, wherein each time the movement data reaches one of the plurality of the thresholds, the microprocessor is configured to detect that one of the user-defined events occurred,

wherein said device is configured to be placed on said user's arm to monitor and record said movement data, wherein said movement sensor is configured to measure movement of said user's arm.

67. The system of claim 13, wherein said microprocessor is configured to store, in said memory, date information associated with the first time stamp information.

68. The system of claim 13, wherein said microprocessor is configured to retrieve said first time stamp information from said real-time clock and associate the retrieved first time stamp information with said first user-defined event.

69. The system of claim 68, wherein said microprocessor is configured to retrieve said first time stamp information from said real-time clock based on the detection of the first user-defined event.

70. The system of claim 13, wherein said memory is configured to continue to store said movement data in response to battery power being lost from said power source.

5

71. The system of claim 13, wherein said movement sensor is configured to constantly checks for said movement.

72. The system of claim 71, wherein said microprocessor is configured to continuously interpret, based on the user-defined operational parameters, said movement data received from said movement sensor.

73. The system of claim 13, wherein said output indicator is configured to display information signaling the occurrence of the first user-defined event based on the detection of the first user-defined event.

74. The system of claim 73, wherein said output indicator is configured to display said information signaling the occurrence of the first user-defined event based on said first time stamp information.

75. The system of claim 13, wherein said output indicator is configured to display information signaling the occurrence of the first user-defined event based on the detection of the first user-defined event and the first time stamp information.

76. The system of claim 13, wherein said at least one of the user-defined operational parameters is a predetermined threshold, and said first user-defined event occurs when the movement data reaches the predetermined threshold.

77. The system of claim 76, wherein said output indicator is configured to display information signaling the occurrence of the first user-defined event when the movement data reaches the predetermined threshold.

78. The system of claim 78, wherein said memory is configured to store said first event information indicating that the predetermined threshold is met.

79. The system of claim 78, wherein said memory is configured to store the first time stamp information in association with said first event information.

80. The system of claim 13, wherein said output indicator is configured to indicate a low battery condition of the device.

81. The system of claim 13, wherein said output indicator is visual, and said output indicator is selected from the group consisting of single monochromatic LEDs, multiple colored lights, and liquid crystal displays.

82. The system of claim 13, wherein said movement data stored in the memory is configured to be downloaded to the computer.

83. The system of claim 82, wherein the portable, self-contained movement measuring device further comprises: software configured to communicate with the program running on the computer, wherein the program is configured to present the downloaded movement data to the user.

84. The system of claim 83, wherein said downloaded movement data is configured to be analyzed by said user via said program.

85. The system of claim 83, wherein said program is configured to interpret said movement data and produce at least one report.

86. The system of claim 83, wherein said program is configured to interpret said movement data and produce at least one history report.

87. The system of claim 86, wherein said at least one history report includes dates and times of said movement data.

88. The system of claim 83, wherein said program is configured to allow the user to program additional reports and histories with respect to said movement data of said user.

89. The system of claim 82, wherein said movement data is configured to be downloaded to said computer, using the download device, via a wired connection.

90. The system of claim 82, wherein said movement data is configured to be downloaded to said computer, using the download device, via a wireless connection.

6

91. The system of claim 76, wherein the output indicator is configured to provide a visual indicator to the user regarding the predetermined threshold being reached.

92. The system of claim 13, wherein the memory is configured to store the user-defined operational parameters, the user-defined operational parameters comprising a plurality of thresholds respectively corresponding to a plurality of notifications, wherein each time the movement data reaches one of the plurality of the thresholds, the microprocessor is configured to detect that one of a plurality of user-defined events occurred.

93. The system of claim 92, wherein when the microprocessor detects that one of the user-defined events occurred based on the movement data reaching one of the plurality of the thresholds, the output indicator displays a corresponding one of the notifications indicating that one of the user-defined events has occurred.

94. The system of claim 92, wherein the plurality of thresholds are different from each other.

95. The system of claim 92, wherein the plurality of notifications are different visual indicators.

96. The system of claim 95, wherein at least one of the visual indicators includes a blinking indicator.

97. The system of claim 13, wherein said output indicator is configured to signal the occurrence of user-defined events.

98. The system of claim 76, wherein said microprocessor is configured to detect occurrence of the first user-defined event by comparing said movement data to said predetermined threshold.

99. The system of claim 13, wherein said device is configured to be placed on said user's arm to monitor and record said movement data.

100. The system of claim 99, wherein said movement sensor is configured to measure movement of said user's arm.

101. The system of claim 13, wherein said movement sensor is configured to measure a walking distance.

102. The system of claim 101, wherein said device is configured to be wearable by the user, and said movement sensor is configured to measure said walking distance of said user.

103. The system of claim 13, wherein said microprocessor is configured to store, in said memory, date information associated with the first time stamp information,

wherein said movement sensor is configured to continuously check for said movement,

wherein said output indicator is configured to display information signaling the occurrence of the first user-defined event based on the detection of the first user-defined event and the first time stamp information, wherein said movement data stored in the memory is configured to be downloaded to the computer,

wherein the device further comprises software configured to communicate with the program which presents the downloaded movement data,

wherein said program is configured to produce at least one report based on said movement data,

wherein the memory is configured to store the user-defined operational parameters, the user-defined operational parameters comprising a plurality of thresholds respectively corresponding to a plurality of notifications, wherein each time the movement data reaches one of the plurality of the thresholds, the microprocessor is configured to detect that one of the user-defined events occurred,

wherein said device is configured to be placed on said user's arm to monitor and record said movement data, wherein said movement sensor is configured to measure movement of said user's arm.

104. The method of claim 20, further comprising: storing, in said memory, date information associated with the first time stamp information.

105. The method of claim 20, further comprising: retrieving said first time stamp information from said real-time clock and associate the retrieved first time stamp information with said first user-defined event.

106. The method of claim 105, further comprising: retrieving said first time stamp information from said real-time clock based on the detection of the first user-defined event.

107. The method of claim 20, wherein said storing comprises continuously storing said movement data after battery power is lost from a power source of the portable, self-contained movement measuring device.

108. The method of claim 20, further comprising: continuously monitoring for said physical movement using a movement sensor of the portable, self-contained movement measuring device.

109. The method of claim 108, wherein said interpreting comprises: continuously interpreting, based on the user-defined operational parameters, said physical movement data.

110. The method of claim 20, further comprising: displaying, using an output indicator of the portable, self-contained movement measuring device, information signaling the occurrence of the first user-defined event based on the detection of the user-defined event.

111. The method of claim 110, wherein said output indicator displays said information signaling the occurrence of the first user-defined event based on said first time stamp information.

112. The method of claim 20, further comprising: displaying, using an output indicator included the portable, self-contained movement measuring device, information signaling the occurrence of the first user-defined event based on the detection of the first user-defined event and the first time stamp information.

113. The method of claim 20, wherein said at least one of the user-defined operational parameters is a predetermined threshold, and said first user-defined event occurs when the movement data reaches the predetermined threshold.

114. The method of claim 113, wherein an output indicator of the portable, self-contained movement measuring device displays information signaling the occurrence of the first user-defined event when the movement data reaches the predetermined threshold.

115. The method of claim 113, further comprising: storing, in said memory, said first event information indicating that the predetermined threshold is met.

116. The method of claim 115, further comprising: storing, in said memory, the first time stamp information in association with said first event information.

117. The method of claim 20, further comprising: indicating a low battery condition, using an output indicator of the portable, self-contained movement measuring device.

118. The method of claim 20, wherein said physical movement data stored in the memory is the interpreted physical movement data, and said stored physical movement data is configured to be downloaded to a computer.

119. The method of claim 118, further comprising: communicating with external software, wherein the external software is configured to present said interpreted physical movement data to the user.

120. The method of claim 119, wherein said external software is configured to run on a computer.

121. The method of 20, further comprising: producing a report based on said interpreted physical movement data.

122. The method of 119, further comprising: producing at least one report based on said interpreted physical movement data using the external software.

123. The method of claim 119, further comprising: producing at least one history report based on said interpreted physical movement data using the external software.

124. The method of claim 123, wherein said at least one history report includes dates and times of said physical movement data.

125. The method of claim 119, further comprising: providing additional reports and histories with respect to said interpreted physical movement data, wherein the additional reports and histories are programmed by the user via the external software.

126. The method of claim 118, wherein said physical movement data is configured to be downloaded to said computer via a wired connection.

127. The method of claim 118, wherein said movement data is configured to be downloaded to the computer via a wireless connection.

128. The method of claim 113, further comprising: providing, via an output indicator of the portable, self-contained movement measuring device, a visual indicator to the user regarding the predetermined threshold being reached.

129. The method of claim 20, further comprising: storing the user-defined operational parameters, the user-defined operational parameters comprising a plurality of thresholds respectively corresponding to a plurality of notifications, wherein the detecting comprises detecting occurrence of one of a plurality of user-defined events each time the movement data reaches one of the plurality of the thresholds.

130. The method of claim 129, wherein in response to detecting that one of the user-defined events occurred based on the movement data reaching one of the plurality of the thresholds, the method further comprises: displaying, via an output indicator of the portable, self-contained movement measuring device, a corresponding one of the notifications indicating that one of the user-defined events has occurred.

131. The method of claim 129, wherein the plurality of thresholds are different from each other.

132. The method of claim 129, wherein the plurality of notifications are different visual indicators.

133. The method of claim 132, wherein at least one of the visual indicators includes a blinking indicator.

134. The method of claim 20, further comprising: signaling, using an output indicator included in the portable, self-contained movement measuring device, the occurrence of user-defined events.

135. The method of claim 113, wherein the detecting comprises comparing said physical movement data to said predetermined threshold.

136. The method of claim 20, wherein said body part is a user's arm, and said measuring the data comprises monitoring and recording the physical movement of said user's arm.

137. The method of claim 136, wherein said measuring the data comprises measuring the data using a movement sensor of the portable, self-contained movement measuring device.

138. The method of claim 20, further comprising: measuring a walking distance based on the interpreted physical movement data.

139. The method of claim 20, further comprising:
 storing, in said memory, date information associated with
 the first time stamp information;
 continuously monitoring for said physical movement using
 a movement sensor of the portable, self-contained move- 5
 ment measuring device;
 displaying, using an output indicator included the por-
 table, self-contained movement measuring device, infor-
 mation signaling the occurrence of the first user-defined
 event based on the detection of the first user-defined 10
 event and the first time stamp information,
 wherein said physical movement data stored in the memory
 is the interpreted physical movement data, and said
 stored physical movement data is configured to be down-
 loaded to a computer;
 communicating with external software configured to run
 on the computer and present said interpreted physical
 movement data to the user;
 producing a report based on said interpreted physical
 movement data using the external software; and
 storing the user-defined operational parameters, the user-
 defined operational parameters comprising a plurality
 of thresholds respectively corresponding to a plurality of
 notifications, wherein the detecting comprises detecting
 occurrence of one of a plurality of user-defined events
 each time the movement data reaches one of the plurality
 of the thresholds,
 wherein said body part is a user's arm, and said measuring
 the data comprises monitoring and recording the physi-
 cal movement of said user's arm.

140. The device of claim 1, wherein the user-defined opera-
 tional parameters comprise a first predetermined threshold
 and a second predetermined threshold different from the first
 predetermined threshold,
 wherein the first user-defined event occurs when the move- 35
 ment data reaches the first predetermined threshold and
 a second user-defined event occurs when the movement
 data reaches the second predetermined threshold,
 wherein said microprocessor is configured to interpret said
 movement data to determine whether the movement data 40
 reaches the first predetermined threshold and whether
 the movement data reaches the second predetermined
 threshold.

141. The device of claim 140, wherein the output indicator
 is configured to display first information indicating occur- 45
 rence of the first user-defined event when it is determined
 that the first predetermined threshold is met, and configured
 to display second information indicating occurrence of the
 second user-defined event when it is determined that the
 second predetermined threshold is met.

142. The device of claim 141, wherein the displayed first
 information is different from the displayed second infor-
 mation.

143. The device of claim 1, wherein the first user-defined
 event is a movement exceeding a user-defined angle limit
 and the first time stamp information reflects a time at
 which the movement exceeded the user-defined angle limit.

144. The device of claim 1, wherein said first user-defined
 event is a predetermined type of movement.

145. The device of claim 144, wherein the predetermined 60
 type of movement is movement exceeding a predetermined
 angle limit.

146. The device of claim 144, wherein the predetermined
 type of movement is movement exceeding a predefined speed.

147. The device of claim 144, wherein the predetermined 65
 type of movement is no movement for a predetermined
 amount of time.

148. The device of claim 144, wherein the predetermined
 type of movement is a maximum number of incorrect move-
 ments allowed in a predetermined time period.

149. The device of claim 1, wherein said microprocessor is
 configured to detect a second event based on the movement
 data and at least one of the user-defined operational param-
 eters, and said microprocessor is configured to store, in
 said memory, second event information related to the
 detected second event along with second time stamp
 information reflecting a time at which the movement data
 causing the second event occurred.

150. The device of claim 149, wherein said second event is
 a predetermined type of movement.

151. The device of claim 150, wherein the predetermined
 type of movement is movement exceeding a predetermined
 angle limit.

152. The device of claim 150, wherein the predetermined
 type of movement is movement exceeding a predefined speed.

153. The device of claim 150, wherein the predetermined
 type of movement is no movement for a predetermined
 amount of time.

154. The device of claim 150, wherein the predetermined
 type of movement is a maximum number of incorrect move-
 ments allowed in a predetermined time period.

155. The system of claim 13, wherein the user-defined
 operational parameters comprise a first predetermined
 threshold and a second predetermined threshold different
 from the first predetermined threshold,
 wherein the first user-defined event occurs when the move-
 ment data reaches the first predetermined threshold and
 a second user-defined event occurs when the movement
 data reaches the second predetermined threshold,
 wherein said microprocessor is configured to interpret said
 movement data to determine whether the movement data
 reaches the first predetermined threshold and whether
 the movement data reaches the second predetermined
 threshold.

156. The system of claim 155, wherein the output indicator
 is configured to display first information indicating occur-
 rence of the first user-defined event when it is determined
 that the first predetermined threshold is met, and configured
 to display second information indicating occurrence of the
 second user-defined event when it is determined that the
 second predetermined threshold is met.

157. The system of claim 156, wherein the displayed first
 information is different from the displayed second infor-
 mation.

158. The system of claim 13, wherein the first user-defined
 event is a movement exceeding a user-defined angle limit
 and the first time stamp information reflects a time at
 which the movement exceeded the user-defined angle limit.

159. The system of claim 13, wherein said first user-defined
 event is a predetermined type of movement.

160. The system of claim 159, wherein the predetermined
 type of movement is movement exceeding a predetermined
 angle limit.

161. The system of claim 159, wherein the predetermined
 type of movement is movement exceeding a predefined speed.

162. The system of claim 159, wherein the predetermined
 type of movement is no movement for a predetermined
 amount of time.

163. The system of claim 159, wherein the predetermined
 type of movement is a maximum number of incorrect move-
 ments allowed in a predetermined time period.

164. The system of claim 13, wherein said microprocessor
 is configured to detect a second event based on the movement
 data and at least one of the user-defined operational param-

eters, and said microprocessor is configured to store, in said memory, second event information related to the detected second event along with second time stamp information reflecting a time at which the movement data causing the second event occurred.

165. The system of claim 164, wherein said second event is a predetermined type of movement.

166. The system of claim 165, wherein the predetermined type of movement is movement exceeding a predetermined angle limit.

167. The system of claim 165, wherein the predetermined type of movement is movement exceeding a predefined speed.

168. The system of claim 165, wherein the predetermined type of movement is no movement for a predetermined amount of time.

169. The system of claim 165, wherein the predetermined type of movement is a maximum number of incorrect movements allowed in a predetermined time period.

170. The system of claim 13, wherein said movement sensor comprises at least one accelerometer.

171. The method of claim 20, wherein the user-defined operational parameters comprise a first predetermined threshold and a second predetermined threshold different from the first predetermined threshold,

wherein the first user-defined event occurs when the movement data reaches the first predetermined threshold and a second user-defined event occurs when the movement data reaches the second predetermined threshold,

wherein said interpreting comprises interpreting said movement data to determine whether the movement data reaches the first predetermined threshold and whether the movement data reaches the second predetermined threshold.

172. The method of claim 171, further comprising: displaying, using an output indicator included in the portable, self-contained movement measuring device, first information indicating occurrence of the first user-defined event when it is determined that the first predetermined threshold is met and second information indicating occurrence of the second user-defined event when it is determined that the second predetermined threshold is met.

173. The method of claim 172, wherein the displayed first information is different from the displayed second information.

174. The method of claim 20, wherein the first user-defined event is a movement exceeding a user-defined angle limit and the first time stamp information reflects a time at which the movement exceeded the user-defined angle limit.

175. The method of claim 20, wherein said first user-defined event is a predetermined type of movement.

176. The method of claim 175, wherein the predetermined type of movement is movement exceeding a predetermined angle limit.

177. The method of claim 175, wherein the predetermined type of movement is movement exceeding a predefined speed.

178. The method of claim 175, wherein the predetermined type of movement is no movement for a predetermined amount of time.

179. The method of claim 175, wherein the predetermined type of movement is a maximum number of incorrect movements allowed in a predetermined time period.

180. The method of claim 20, further comprising: detecting, using the microprocessor, a second event based on the movement data and at least one of the user-defined operational parameters; and

storing, in said memory, second event information related to the detected second event along with second time stamp information reflecting a time at which the movement data causing the second event occurred.

181. The method of claim 180, wherein said second event is a predetermined type of movement.

182. The method of claim 181, wherein the predetermined type of movement is movement exceeding a predetermined angle limit.

183. The method of claim 181, wherein the predetermined type of movement is movement exceeding a predefined speed.

184. The method of claim 181, wherein the predetermined type of movement is no movement for a predetermined amount of time.

185. The method of claim 181, wherein the predetermined type of movement is a maximum number of incorrect movements allowed in a predetermined time period.

* * * * *

Please Enter
/DD/
01/31/2015

REEXAMINATION

IN THE UNITED STATES PATENT AND TRADEMARK OFFICE

In re Patent of

Docket No: A209779

Theodore L. Brann

Control No.: 90/013,201

Group Art Unit: 3993

Confirmation No.: 9930

Examiner: DEMILLE, DANTON D

Filed: April 4, 2014

For: TRAINING AND SAFETY DEVICE, SYSTEM AND METHOD TO AID IN PROPER
MOVEMENT DURING PHYSICAL ACTIVITY

RESPONSE TO *EX PARTE* REEXAMINATION FINAL OFFICE ACTION

MAIL STOP *Ex Parte* Reexam

Attn: Central Reexamination Unit
Commissioner for Patents
P.O. Box 1450
Alexandria, VA 22313-1450

Sir:

In response to the Office Action dated December 10, 2014, Patent Owner respectfully requests reconsideration of this reexamination application in light of the following amendments and remarks.

TABLE OF CONTENTS

I.	AMENDMENTS TO THE CLAIMS	2
II.	STATUS OF THE CLAIMS AND EXEMPLARY SUPPORT FOR CLAIM AMENDMENTS	41
III.	REMARKS	47



UNITED STATES PATENT AND TRADEMARK OFFICE

UNITED STATES DEPARTMENT OF COMMERCE
United States Patent and Trademark Office
Address: COMMISSIONER FOR PATENTS
P.O. Box 1450
Alexandria, Virginia 22313-1450
www.uspto.gov

Table with 5 columns: APPLICATION NO., FILING DATE, FIRST NAMED INVENTOR, ATTORNEY DOCKET NO., CONFIRMATION NO.
90/013,201 04/04/2014 6059576 A209779 9930

23373 7590 02/18/2015
SUGHRUE MION, PLLC
2100 PENNSYLVANIA AVENUE, N.W.
SUITE 800
WASHINGTON, DC 20037

Table with 1 column: EXAMINER

DEMILLE, DANTON D

Table with 2 columns: ART UNIT, PAPER NUMBER

3993

Table with 2 columns: MAIL DATE, DELIVERY MODE

02/18/2015

PAPER

Please find below and/or attached an Office communication concerning this application or proceeding.

The time period for reply, if any, is set in the attached communication.

Examiner-Initiated Interview Summary	Application No. 90/013,201	Applicant(s) 6059576	
	Examiner DANTON DE MILLE	Art Unit 3993	

All participants (applicant, applicant's representative, PTO personnel):

(1) Danton DeMille. (3)_____.

(2) Quadeer Ahmed. (4)_____.

Date of Interview: 30 January 2015.

Type: Telephonic Video Conference
 Personal [copy given to: applicant applicant's representative]

Exhibit shown or demonstration conducted: Yes No.
If Yes, brief description: _____.

Issues Discussed 101 112 102 103 Others
(For each of the checked box(es) above, please describe below the issue and detailed description of the discussion)

Claim(s) discussed: 1, 13 and 20.

Identification of prior art discussed: none.

Substance of Interview
(For each issue discussed, provide a detailed description and indicate if agreement was reached. Some topics may include: identification or clarification of a reference or a portion thereof, claim interpretation, proposed amendments, arguments of any applied references etc...)

Agreed to changes to the independent claims to more clearly define the invention over the prior art by setting forth that the microprocessor detects "a first user-defined event based on the movement data and at least one of the user-defined operational parameters regarding the movement data and storing first event information related to the detected first user-defined even along with first time stamp information reflecting a time at which the movement data causing the first user-defined event occurred".

Applicant recordation instructions: It is not necessary for applicant to provide a separate record of the substance of interview.

Examiner recordation instructions: Examiners must summarize the substance of any interview of record. A complete and proper recordation of the substance of an interview should include the items listed in MPEP 713.04 for complete and proper recordation including the identification of the general thrust of each argument or issue discussed, a general indication of any other pertinent matters discussed regarding patentability and the general results or outcome of the interview, to include an indication as to whether or not agreement was reached on the issues raised.

Attachment

/DANTON DE MILLE/ Primary Examiner, Art Unit 3993	
--	--

Notice of Intent to Issue Ex Parte Reexamination Certificate	Control No. 90/013,201	Patent Under Reexamination 6059576	
	Examiner DANTON DE MILLE	Art Unit 3993	AIA (First Inventor to File) Status No

-- The MAILING DATE of this communication appears on the cover sheet with the correspondence address --

1. Prosecution on the merits is (or remains) closed in this *ex parte* reexamination proceeding. This proceeding is subject to reopening at the initiative of the Office or upon petition. *Cf.* 37 CFR 1.313(a). A Certificate will be issued in view of
 - (a) Patent owner's communication(s) filed: 09 January 2015.
 - (b) Patent owner's failure to file an appropriate timely response to the Office action mailed: _____.
 - (c) Patent owner's failure to timely file an Appeal Brief (37 CFR 41.31).
 - (d) The decision on appeal by the Board of Patent Appeals and Interferences Court dated _____
 - (e) Other: _____.
2. The Reexamination Certificate will indicate the following:
 - (a) Change in the Specification: Yes No
 - (b) Change in the Drawing(s): Yes No
 - (c) Status of the Claim(s):
 - (1) Patent claim(s) confirmed: _____.
 - (2) Patent claim(s) amended (including dependent on amended claim(s)): 1-29
 - (3) Patent claim(s) canceled: _____.
 - (4) Newly presented claim(s) patentable: See Continuation Sheet.
 - (5) Newly presented canceled claims: See Continuation Sheet.
 - (6) Patent claim(s) previously currently disclaimed: _____
 - (7) Patent claim(s) not subject to reexamination: _____.
3. A declaration(s)/affidavit(s) under **37 CFR 1.130(b)** was/were filed on _____.
4. Note the attached statement of reasons for patentability and/or confirmation. Any comments considered necessary by patent owner regarding reasons for patentability and/or confirmation must be submitted promptly to avoid processing delays. Such submission(s) should be labeled: "Comments On Statement of Reasons for Patentability and/or Confirmation."
5. Note attached NOTICE OF REFERENCES CITED (PTO-892).
6. Note attached LIST OF REFERENCES CITED (PTO/SB/08 or PTO/SB/08 substitute).
7. The drawing correction request filed on _____ is: approved disapproved.
8. Acknowledgment is made of the priority claim under 35 U.S.C. § 119(a)-(d) or (f).
 - a) All b) Some* c) None of the certified copies have
 - been received.
 - not been received.
 - been filed in Application No. _____.
 - been filed in reexamination Control No. _____.
 - been received by the International Bureau in PCT Application No. _____.

* Certified copies not received: _____.
9. Note attached Examiner's Amendment.
10. Note attached Interview Summary (PTO-474).
11. Other: _____.

All correspondence relating to this reexamination proceeding should be directed to the **Central Reexamination Unit** at the mail, FAX, or hand-carry addresses given at the end of this Office action.

/Danton DeMille/
Primary Examiner
Art Unit: 3993

cc: Requester (if third party requester)

U.S. Patent and Trademark Office
PTOL-469 (Rev. 08-13)

Notice of Intent to Issue Ex Parte Reexamination Certificate

Part of Paper No 20150130

Continuation of (4) Newly presented claim(s) patentable: 31-33,35-56,58,60,61,64-66,68-73,75-77,79-99,101,103,104,107-116,118-120,122-142,144,146,147 and 150-204.

Continuation of (5) Newly presented canceled claims: 30,34,57,59,62,63,67,74,78,100,102,105,106,117,121,143,145,148 and 149.

The present application is being examined under the pre-AIA first to invent provisions.

EXAMINER'S AMENDMENT

An examiner's amendment to the record appears below. The changes made by this examiner's amendment will be reflected in the reexamination certificate to issue in due course.

Authorization for this examiner's amendment was given in a telephone interview with Quadeer Ahmed on 30 January 2015.

The patent has been amended as follows:

Claim 1. (currently amended): A portable, self-contained device for monitoring movement of body parts during physical activity, said device comprising:

- a movement sensor capable of measuring data associated with unrestrained movement in any direction and generating signals indicative of said movement; a power source; a microprocessor connected to said movement sensor and to said power source, said microprocessor capable of receiving, interpreting, storing and responding to said movement data based on user-defined operational parameters, detecting a first user-defined event based on the movement data and at least one of the user-defined operational parameters regarding the movement data, and storing first event information related to the detected first user-defined event along with first time stamp information reflecting a time at which the movement data causing the first user-defined event occurred:
- at least one user input connected to said microprocessor for controlling the operation of said device;

a real-time clock connected to said microprocessor; memory for storing said movement data; and

an output indicator connected to said microprocessor for signaling the occurrence of user-defined events;

wherein said movement sensor measures the angle and velocity of said movement.

Claim 13. (currently amended): A system to aid in training and safety during physical activity, said system comprising

a portable, self-contained movement measuring device, said movement measuring device further comprising

a movement sensor capable of measuring data associated with unrestrained movement in any direction and generating signals indicative of said movement; a power source; a microprocessor connected to said power source, said microprocessor capable of receiving, interpreting, storing and responding to said movement data based on user-defined operational parameters, detecting a first user-defined event based on the movement data and at least one of the user-defined operational parameters regarding the movement data, and storing first event information related to the detected first user-defined event along with first time stamp information reflecting a time at which the movement data causing the first user-defined event occurred;

at least one user input connected to said microprocessor for controlling the operation of said device;

a real-time clock connected to said microprocessor; memory for storing said movement data;

at least one input/output port connected to said microprocessor for downloading said data and uploading said operational parameters; and

an output indicator connected to said microprocessor;

a computer running a program capable of interpreting and reporting said movement data based on said operational parameters; and

a download device electronically connected to said movement measuring device and said computer for transmitting said movement data and operational parameters between said movement measuring device and said computer for analysis, reporting and operation purposes;

wherein said movement sensor measures the angle and velocity of said movement.

Claim 20. (currently amended): A method to monitor physical movement of a body part comprising the steps of:

attaching a portable, self-contained movement measuring device to said body part for measuring unrestrained movement in any direction;

measuring data associated with said physical movement;

interpreting, using a microprocessor included in the portable, self-contained movement measuring device, said physical movement data based on user-defined operational parameters and a real-time clock; [and]

storing said data in memory;

detecting, using the microprocessor, a first user-defined event based on the movement data and at least one of the user-defined operational parameters regarding the movement data;
and

storing, in said memory, first event information related to the detected first user-defined event along with first time stamp information reflecting a time at which the movement data causing the first user-defined event occurred.

STATEMENT OF REASONS FOR PATENTABILITY AND/OR CONFIRMATION

The following is an examiner's statement of reasons for patentability and/or confirmation of the claims found patentable in this reexamination proceeding:

While the prior art teaches a portable, self-contained device for monitoring movement of body parts during physical activity comprising a movement sensor, a power source, a user input, a real-time clock, memory, an output indicator and a microprocessor capable of receiving, interpreting, storing and responding to the movement data based on user-defined operational parameters. There is no teaching or fair suggestion for the microprocessor to detect a first user-defined event based on the movement data and at least one of the user-defined operational parameter regarding the movement data, and storing first event information related to the detected first user-defined event along with first time stamp information reflecting a time at which the movement data causing the first user-defined event occurred.

Additionally the prior art teaches a method to monitor physical movement of a body part comprising the steps of attaching a portable, self-contained movement measuring device to the body part, measuring data associated with the physical movement, storing data in memory,

interpreting, using a microprocessor, the physical movement data based on user-defined operational parameters and a real-time clock. However, there is no teaching or fair suggestion to detect, using the microprocessor, a first user-defined event based on the movement data and at least one user-defined operational parameters regarding the movement data and storing in memory first event information related to the detected first user-defined event along with first time stamp information reflecting a time at which the movement data causing the first user-defined event occurred.

Any comments considered necessary by PATENT OWNER regarding the above statement must be submitted promptly to avoid processing delays. Such submission by the patent owner should be labeled: "Comments on Statement of Reasons for Patentability and/or Confirmation" and will be placed in the reexamination file.

CONCLUSION

All correspondence relating to this *ex parte* reexamination proceeding should be directed:

By EFS: Registered users may submit via the electronic filing system EFS-Web, at <https://efs.uspto.gov/efile/myportal/efs-registered>.

By Mail to: Mail Stop *Ex Parte* Reexam
Central Reexamination Unit
Commissioner for Patents
United States Patent & Trademark Office
P.O. Box 1450 Alexandria, VA 22313-1450

By FAX to: (571) 273-9900
Central Reexamination Unit

By hand: Customer Service Window
Randolph Building
401 Dulany Street
Alexandria, VA 22314

For EFS-Web transmissions, 37 CFR 1.8(a)(1)(i) (C) and (ii) states that correspondence (except for a request for reexamination and a corrected or replacement request for reexamination) will be considered timely filed if (a) it is transmitted via the Office's electronic filing system in accordance with 37 CFR 1.6(a)(4), and (b) includes a certificate of transmission for each piece of correspondence stating the date of transmission, which is prior to the expiration of the set period of time in the Office action.

Any inquiry concerning this communication or earlier communications from the Examiner, or as to the status of this proceeding, should be directed to the Central Reexamination Unit at telephone number (571) 272-7705.

Telephone Number for reexamination inquiries:

Reexamination and Amendment Practice	(571) 272-7703
Central Reexam Unit (CRU)	(571) 272-7705
Reexamination Facsimile Transmission No.	(571) 273-9900

/Danton DeMille/
Patent Reexamination Specialist
Central Reexamination Unit 3993
(571) 272-4974
17 February 2015

Conferee: **/JGF/**

Conferee: **/EDL/**

Examiner-Initiated Interview Summary	Application No. 90/013,201	Applicant(s) 6059576	
	Examiner DANTON DE MILLE	Art Unit 3993	

All participants (applicant, applicant's representative, PTO personnel):

(1) Danton DeMille. (3)_____.

(2) Quadeer Ahmed. (4)_____.

Date of Interview: 30 January 2015.

Type: Telephonic Video Conference
 Personal [copy given to: applicant applicant's representative]

Exhibit shown or demonstration conducted: Yes No.
If Yes, brief description: _____.

Issues Discussed 101 112 102 103 Others
(For each of the checked box(es) above, please describe below the issue and detailed description of the discussion)

Claim(s) discussed: 1, 13 and 20.

Identification of prior art discussed: none.

Substance of Interview
(For each issue discussed, provide a detailed description and indicate if agreement was reached. Some topics may include: identification or clarification of a reference or a portion thereof, claim interpretation, proposed amendments, arguments of any applied references etc...)

Agreed to changes to the independent claims to more clearly define the invention over the prior art by setting forth that the microprocessor detects "a first user-defined event based on the movement data and at least one of the user-defined operational parameters regarding the movement data and storing first event information related to the detected first user-defined even along with first time stamp information reflecting a time at which the movement data causing the first user-defined event occurred".

Applicant recordation instructions: It is not necessary for applicant to provide a separate record of the substance of interview.

Examiner recordation instructions: Examiners must summarize the substance of any interview of record. A complete and proper recordation of the substance of an interview should include the items listed in MPEP 713.04 for complete and proper recordation including the identification of the general thrust of each argument or issue discussed, a general indication of any other pertinent matters discussed regarding patentability and the general results or outcome of the interview, to include an indication as to whether or not agreement was reached on the issues raised.

Attachment

/DANTON DE MILLE/ Primary Examiner, Art Unit 3993	
--	--



UNITED STATES PATENT AND TRADEMARK OFFICE

UNITED STATES DEPARTMENT OF COMMERCE
 United States Patent and Trademark Office
 Address: COMMISSIONER FOR PATENTS
 P.O. Box 1450
 Alexandria, Virginia 22313-1450
 www.uspto.gov

BIB DATA SHEET

CONFIRMATION NO. 9930

SERIAL NUMBER 90/013,201	FILING or 371(c) DATE 04/04/2014 RULE	CLASS 434	GROUP ART UNIT 3993	ATTORNEY DOCKET NO. A209779		
APPLICANTS INVENTORS 6059576, Residence Not Provided; LOGANTREE LP(OWNER), BOERNE, TX; PATENT OWNER, WASHINGTON, DC; ** CONTINUING DATA ***** This application is a REX of 08/976,228 11/21/1997 PAT 6059576 ** FOREIGN APPLICATIONS ***** ** IF REQUIRED, FOREIGN FILING LICENSE GRANTED **						
Foreign Priority claimed <input type="checkbox"/> Yes <input checked="" type="checkbox"/> No	35 USC 119(a-d) conditions met <input type="checkbox"/> Yes <input checked="" type="checkbox"/> No	<input type="checkbox"/> Met after Allowance	STATE OR COUNTRY	SHEETS DRAWINGS	TOTAL CLAIMS	INDEPENDENT CLAIMS
Verified and /DANTON D Acknowledge DEMILLE/ Examiner's Signature	Initials			29	3	
ADDRESS SUGHRUE MION, PLLC 2100 PENNSYLVANIA AVENUE, N.W. SUITE 800 WASHINGTON, DC 20037 UNITED STATES						
TITLE TRAINING AND SAFETY DEVICE, SYSTEM AND METHOD TO AID IN PROPER MOVEMENT DURING PHYSICAL ACTIVITY						
FILING FEE RECEIVED 12000	FEES: Authority has been given in Paper No. _____ to charge/credit DEPOSIT ACCOUNT No. _____ for following:		<input type="checkbox"/> All Fees <input type="checkbox"/> 1.16 Fees (Filing) <input type="checkbox"/> 1.17 Fees (Processing Ext. of time) <input type="checkbox"/> 1.18 Fees (Issue) <input type="checkbox"/> Other _____ <input type="checkbox"/> Credit			

Issue Classification 	Application/Control No. 90013201	Applicant(s)/Patent Under Reexamination 6059576
	Examiner DANTON DEMILLE	Art Unit 3993

CPC					Type	Version
Symbol						
A61B	5		1116		F	2013-01-01
A63B	2220		40		A	2013-01-01

CPC Combination Sets				
Symbol	Type	Set	Ranking	Version

NONE		Total Claims Allowed:	
(Assistant Examiner)	(Date)	185	
/DANTON DEMILLE/ Primary Examiner. Art Unit 3993	1/30/15	O.G. Print Claim(s)	O.G. Print Figure
(Primary Examiner)	(Date)	1	5A, 5B, 5C, 5D

Issue Classification 	Application/Control No. 90013201	Applicant(s)/Patent Under Reexamination 6059576
	Examiner DANTON DEMILLE	Art Unit 3993

US ORIGINAL CLASSIFICATION						INTERNATIONAL CLASSIFICATION							
CLASS		SUBCLASS				CLAIMED				NON-CLAIMED			
434		247				A	6	1	B	5 / 11 (2006.01.01)			
CROSS REFERENCE(S)						A	6	3	B	24 / 00 (2006.01.01)			
						CLASS		SUBCLASS (ONE SUBCLASS PER BLOCK)					
600	595												
482	8	901											
340	686*1												
702	101												
601	34												

NONE		Total Claims Allowed:	
		185	
(Assistant Examiner)	(Date)		
/DANTON DEMILLE/ Primary Examiner. Art Unit 3993	1/30/15	O.G. Print Claim(s)	O.G. Print Figure
(Primary Examiner)	(Date)	1	5A, 5B, 5C, 5D

Issue Classification 	Application/Control No. 90013201	Applicant(s)/Patent Under Reexamination 6059576
	Examiner DANTON DEMILLE	Art Unit 3993

<input checked="" type="checkbox"/> Claims renumbered in the same order as presented by applicant															<input type="checkbox"/> CPA		<input type="checkbox"/> T.D.		<input type="checkbox"/> R.1.47	
Final	Original	Final	Original	Final	Original	Final	Original	Final	Original	Final	Original	Final	Original	Final	Original					
1																				
2																				
3																				
4																				
5																				
6																				

NONE		Total Claims Allowed:	
(Assistant Examiner)	(Date)	185	
/DANTON DEMILLE/ Primary Examiner.Art Unit 3993	1/30/15	O.G. Print Claim(s)	O.G. Print Figure
(Primary Examiner)	(Date)	1	5A, 5B, 5C, 5D

Search Notes



Application/Control No.

90/013,201

Examiner

DANTON DE MILLE

Applicant(s)/Patent under Reexamination

6059576

Art Unit

3993

SEARCHED			
Class	Subclass	Date	Examiner

INTERFERENCE SEARCHED			
Class	Subclass	Date	Examiner

SEARCH NOTES (INCLUDING SEARCH STRATEGY)		
	DATE	EXMR
Reviewed patented file's prosecution history	1/30/2015	/DD/
See attached classification text search notes	1/30/2015	/DD/

EAST Search History

EAST Search History (Prior Art)

Ref #	Hits	Search Query	DBs	Default Operator	Plurals	Time Stamp
S11	8	("5636146" "6018705" "6266623").PN.	US-PGPUB; USPAT; USOCR; FPRS; EPO; JPO; DERWENT	OR	OFF	2014/04/14 11:37
S20	11555355	low battery	US-PGPUB; USPAT; USOCR; FPRS; EPO; JPO; DERWENT	OR	OFF	2014/04/14 14:20
S21	4	S20 and S11	US-PGPUB; USPAT; USOCR; FPRS; EPO; JPO; DERWENT	OR	OFF	2014/04/14 14:20
S22	23065	low battery	US-PGPUB; USPAT; USOCR; FPRS; EPO; JPO; DERWENT	ADJ	OFF	2014/04/14 14:21
S23	0	S22 and S11	US-PGPUB; USPAT; USOCR; FPRS; EPO; JPO; DERWENT	ADJ	OFF	2014/04/14 14:21
S24	4	(download remot\$4 transmi\$5) and S11	US-PGPUB; USPAT; USOCR; FPRS; EPO; JPO; DERWENT	OR	OFF	2014/04/14 14:42
S26	5	("5636146" "6018705" "6266623" "5348519" "4655928").PN.	USPAT	OR	OFF	2014/04/15 10:18
S27	2	dock\$5 and S26	USPAT	OR	OFF	2014/04/15 10:19
S28	2	(ir or infrared) and S26	USPAT	OR	OFF	2014/04/15 10:26
S29	5	("5636146" "6018705" "6266623" "5348519" "4655928").PN.	USPAT	OR	OFF	2014/04/15 15:47
S30	34126	(time or day) adj3 stamp	USPAT	OR	OFF	2014/04/15 16:47
S31	2067	(601/5,23-40).ccls.	USPAT	OR	OFF	2014/04/15 16:50
S32	3	S30 and S31	USPAT	OR	OFF	2014/04/15 16:50
S33	3231	(600/587-595).ccls.	USPAT	OR	OFF	2014/04/15 16:53
S34	52	S30 and S33	USPAT	OR	OFF	2014/04/15 16:53
S37	29796	"482".clas.	US-PGPUB; USPAT; USOCR	ADJ	ON	2014/04/15 17:00
S39	3166	702/33,41-44,56.ccls.	US-PGPUB; USPAT; USOCR	ADJ	ON	2014/04/15 17:32
S40	7	S30 and S39 and S35	US-PGPUB; USPAT; USOCR	ADJ	ON	2014/04/15 17:32
S41	4	("4665928").PN.	US-PGPUB; USPAT; USOCR; FPRS; EPO;	OR	OFF	2014/04/15 17:51

EAST Search History

			JPO; DERWENT			
S42	3	("5474088").PN.	US-PGPUB; USPAT; USOCR; FPRS; EPO; JPO; DERWENT	OR	OFF	2014/05/12: 14:17
S43	4	("5429140").PN.	US-PGPUB; USPAT; USOCR; FPRS; EPO; JPO; DERWENT	OR	OFF	2014/05/14: 11:01

1/31/2015 4:18:53 PM

C:\Users\ddemille\Documents\EAST\Workspaces\90013201.wsp

Reexamination 	Application/Control No.	Applicant(s)/Patent Under Reexamination
	90/013,201	6059576
	Certificate Date	Certificate Number
		C1

Requester	Correspondence Address:	<input checked="" type="checkbox"/> Patent Owner	<input type="checkbox"/> Third Party
<p>SUGHRUE MION, PLLC 2100 PENNSYLVANIA AVENUE, N.W. SUITE 800 WASHINGTON, DC 20037</p>			

LITIGATION REVIEW <input checked="" type="checkbox"/>	/DDD/	1/30/15
	(examiner initials)	(date)
Case Name		Director Initials
NONE		

COPENDING OFFICE PROCEEDINGS	
TYPE OF PROCEEDING	NUMBER
1. none	
2.	
3.	
4.	

IN THE UNITED STATES PATENT AND TRADEMARK OFFICE

In re *Ex Parte* Reexamination of

Docket No: A209779

Theodore L. Brann

Confirmation No.: 9930

Group Art Unit: 3993

Filed: April 4, 2014

Examiner: DEMILLE, DANTON D

Reexam Control No.: 90/013,201

Reexam Request Filed: April 4, 2014

For: TRAINING AND SAFETY DEVICE, SYSTEM AND METHOD TO AID IN PROPER
MOVEMENT DURING PHYSICAL ACTIVITY

NOTICE OF APPEAL

**MAIL STOP EX PARTE REEXAMINATION
ATTN: CENTRAL REEXAMINATION UNIT**

Commissioner for Patents
P.O. Box 1450
Alexandria, VA 22313-1450

Sir:

Patent Owner hereby appeal to the Board of Patent Appeals and Interferences from the
Final Office Action dated December 10, 2014.

The statutory fee of \$800.00 is being remitted. The USPTO is directed and authorized to
charge all required fees, except for the Issue Fee, to Deposit Account No. 19-4880. Please also
credit any overpayments to said Deposit Account

Respectfully yours,

/John M. Bird/ # 46,027, John M. Bird for

SUGHRUE, MION, PLLC
Telephone: 202.293.7060
Facsimile: 202.293.7860

Quadeer A. Ahmed
Registration No. 60,835

WASHINGTON OFFICE

23373

CUSTOMER NUMBER

Date: February 10, 2015

Electronic Patent Application Fee Transmittal

Application Number:	90013201			
Filing Date:	04-Apr-2014			
Title of Invention:	TRAINING AND SAFETY DEVICE, SYSTEM AND METHOD TO AID IN PROPER MOVEMENT DURING PHYSICAL ACTIVITY			
First Named Inventor/Applicant Name:	6059576			
Filer:	Quadeer A. Ahmed/Shanele Jones			
Attorney Docket Number:	A209779			
Filed as Large Entity				
Filing Fees for ex parte reexam				
Description	Fee Code	Quantity	Amount	Sub-Total in USD(\$)
Basic Filing:				
Pages:				
Claims:				
Miscellaneous-Filing:				
Petition:				
Patent-Appeals-and-Interference:				
Notice of Appeal	1401	1	800	800
Post-Allowance-and-Post-Issuance:				

Description	Fee Code	Quantity	Amount	Sub-Total in USD(\$)
Extension-of-Time:				
Miscellaneous:				
Total in USD (\$)				800

Electronic Acknowledgement Receipt

EFS ID:	21455109
Application Number:	90013201
International Application Number:	
Confirmation Number:	9930
Title of Invention:	TRAINING AND SAFETY DEVICE, SYSTEM AND METHOD TO AID IN PROPER MOVEMENT DURING PHYSICAL ACTIVITY
First Named Inventor/Applicant Name:	6059576
Customer Number:	23373
Filer:	Quadeer A. Ahmed/Shanele Jones
Filer Authorized By:	Quadeer A. Ahmed
Attorney Docket Number:	A209779
Receipt Date:	10-FEB-2015
Filing Date:	04-APR-2014
Time Stamp:	16:51:47
Application Type:	Reexam (Patent Owner)

Payment information:

Submitted with Payment	yes
Payment Type	Deposit Account
Payment was successfully received in RAM	\$800
RAM confirmation Number	3290
Deposit Account	194880
Authorized User	

The Director of the USPTO is hereby authorized to charge indicated fees and credit any overpayment as follows:

Charge any Additional Fees required under 37 C.F.R. Section 1.16 (National application filing, search, and examination fees)

Charge any Additional Fees required under 37 C.F.R. Section 1.17 (Patent application and reexamination processing fees)

Charge any Additional Fees required under 37 C.F.R. Section 1.19 (Document supply fees)

Charge any Additional Fees required under 37 C.F.R. Section 1.21 (Miscellaneous fees and charges)

File Listing:

Document Number	Document Description	File Name	File Size(Bytes)/ Message Digest	Multi Part /.zip	Pages (if appl.)
1	Notice of Appeal Filed	A209779ExParteReexamNotice ofAppealasfiled.pdf	16744 <small>258b396f2f715c3ac2b4ac1bfe5b9bf7e769150c</small>	no	1

Warnings:

Information:

2	Fee Worksheet (SB06)	fee-info.pdf	30610 <small>3335932d8884aa1f2f2de65420b375dd81c92e14</small>	no	2
---	----------------------	--------------	--	----	---

Warnings:

Information:

Total Files Size (in bytes): 47354

This Acknowledgement Receipt evidences receipt on the noted date by the USPTO of the indicated documents, characterized by the applicant, and including page counts, where applicable. It serves as evidence of receipt similar to a Post Card, as described in MPEP 503.

New Applications Under 35 U.S.C. 111

If a new application is being filed and the application includes the necessary components for a filing date (see 37 CFR 1.53(b)-(d) and MPEP 506), a Filing Receipt (37 CFR 1.54) will be issued in due course and the date shown on this Acknowledgement Receipt will establish the filing date of the application.

National Stage of an International Application under 35 U.S.C. 371

If a timely submission to enter the national stage of an international application is compliant with the conditions of 35 U.S.C. 371 and other applicable requirements a Form PCT/DO/EO/903 indicating acceptance of the application as a national stage submission under 35 U.S.C. 371 will be issued in addition to the Filing Receipt, in due course.

New International Application Filed with the USPTO as a Receiving Office

If a new international application is being filed and the international application includes the necessary components for an international filing date (see PCT Article 11 and MPEP 1810), a Notification of the International Application Number and of the International Filing Date (Form PCT/RO/105) will be issued in due course, subject to prescriptions concerning national security, and the date shown on this Acknowledgement Receipt will establish the international filing date of the application.

REEXAMINATION

IN THE UNITED STATES PATENT AND TRADEMARK OFFICE

In re Patent of

Docket No: A209779

Theodore L. Brann

Control No.: 90/013,201

Group Art Unit: 3993

Confirmation No.: 9930

Examiner: DEMILLE, DANTON D

Filed: April 4, 2014

For: TRAINING AND SAFETY DEVICE, SYSTEM AND METHOD TO AID IN PROPER
MOVEMENT DURING PHYSICAL ACTIVITY

RESPONSE TO *EX PARTE* REEXAMINATION FINAL OFFICE ACTION

MAIL STOP *Ex Parte* Reexam

Attn: Central Reexamination Unit
Commissioner for Patents
P.O. Box 1450
Alexandria, VA 22313-1450

Sir:

In response to the Office Action dated December 10, 2014, Patent Owner respectfully requests reconsideration of this reexamination application in light of the following amendments and remarks.

TABLE OF CONTENTS

I.	AMENDMENTS TO THE CLAIMS	2
II.	STATUS OF THE CLAIMS AND EXEMPLARY SUPPORT FOR CLAIM AMENDMENTS	41
III.	REMARKS	47

I. AMENDMENTS TO THE CLAIMS

This listing of claims will replace all prior versions and listings of claims in the proceeding:

LISTING OF CLAIMS:

1. (currently amended): A portable, self-contained device for monitoring movement of body parts during physical activity, said device comprising:

a movement sensor capable of measuring data associated with unrestrained movement in any direction and generating signals indicative of said movement;

a power source;

a microprocessor connected to said movement sensor and to said power source, said microprocessor capable of receiving, interpreting, storing and responding to said movement data based on user-defined operational parameters, detecting a first user-defined event based on the movement data and at least one of the user-defined operational parameters, and storing first event information related to the detected first user-defined event along with first time stamp information reflecting a time at which the movement data causing the first user-defined event occurred;

at least one user input connected to said microprocessor for controlling the operation of said device;

a real-time clock connected to said microprocessor;

memory for storing said movement data; and

an output indicator connected to said microprocessor for signaling the occurrence of user-defined events;

wherein said movement sensor measures the angle and velocity of said movement.

2. (original): The device of claim 1 further comprising at least one input/output port connected to said microprocessor for downloading said data and uploading said operational parameters to and from a computer.

3. (original): The device of claim 1 wherein said device is compact and weighs less than one pound.

4. (original): The device of claim 1 wherein said movement sensor comprises at least one accelerometer.

5. (original): The device of claim 1 wherein said movement sensor can simultaneously detect real time movement along at least two orthogonal axes.

6. (original): The device of claim 1 wherein said movement sensor is housed separately from said microprocessor.

7. (original): The device of claim 1 wherein said monitored body part movement is torso or limb movement.

8. (original): The device of claim 1 wherein said data measured by said movement sensor includes the distance of said movement.

9. (original): The device of claim 1 wherein said output indicator is visual.

10. (original): The device of claim 1 wherein said output indicator is audible.

11. (original): The device of claim 1 wherein said output indicator is tactile.

12. (original): The device of claim 1 wherein said user input is a switch.

13. (currently amended): A system to aid in training and safety during physical activity, said system comprising

a portable, self-contained movement measuring device, said movement measuring device further comprising

a movement sensor capable of measuring data associated with unrestrained movement in any direction and generating signals indicative of said movement;

a power source;

a microprocessor connected to said power source, said microprocessor capable of receiving, interpreting, storing and responding to said movement data based on user-defined operational parameters, detecting a first user-defined event based on the movement data and at least one of the user-defined operational parameters, and storing first event information related to

the detected first user-defined event along with first time stamp information reflecting a time at which the movement data causing the first user-defined event occurred;

at least one user input connected to said microprocessor for controlling the operation of said device;

a real-time clock connected to said microprocessor;

memory for storing said movement data;

at least one input/output port connected to said microprocessor for downloading said data and uploading said operational parameters; and

an output indicator connected to said microprocessor;

a computer running a program capable of interpreting and reporting said movement data based on said operational parameters; and

a download device electronically connected to said movement measuring device and said computer for transmitting said movement data and operational parameters between said movement measuring device and said computer for analysis, reporting and operation purposes;

wherein said movement sensor measures the angle and velocity of said movement.

14. (original): The system of claim 13 wherein said computer is a personal computer.

15. (original): The system of claim 13 wherein said computer is connected to a network of other computers.

16. (original): The system of claim 13 wherein said download device is a physical docking station.

17. (original): The system of claim 13 wherein said download device is a wireless device.

18. (original): The system of claim 17 wherein said wireless device uses radio frequency.

19. (original): The system of claim 17 wherein said wireless device uses infrared light.

20. (currently amended): A method to monitor physical movement of a body part comprising the steps of:

attaching a portable, self-contained movement measuring device to said body part for measuring unrestrained movement in any direction;

measuring data associated with said physical movement;

interpreting, using a microprocessor included in the portable, self-contained movement measuring device, said physical movement data based on user-defined operational parameters and a real-time clock; [and]

storing said data in memory;

detecting, using the microprocessor, a first user-defined event based on the movement data and at least one of the user-defined operational parameters; and

storing, in said memory, first event information related to the detected first user-defined event along with first time stamp information reflecting a time at which the movement data causing the first user-defined event occurred.

21. (original): The method of claim 20 wherein said physical movement data includes velocity data of said movement, angle measurement data taken along at least two orthogonal axes, and related date and time data.

22. (original): The method of claim 21 further comprising the step of defining said parameters for a specific physical movement prior to said interpreting step.

23. (original): The method of claim 21 further comprising the step of downloading said data from said movement measuring device to a computer for reporting and analysis purposes.

24. (original): The method of claim 21 wherein said interpreting step comprises teaching an individual how to properly perform said physical movement.

25. (original): The method of claim 20 wherein said movement measuring device is an accelerometer.

26. (original): The method of claim 20 further comprising the step of providing real time feedback regarding said movement.

27. (original): The method of claim 26 wherein said physical movement is physical labor.

28. (original): The method of claim 26 wherein said physical movement is an exercise related to medical treatment.

29. (original): The method of claim 26 wherein said physical movement is an exercise to improve technique related to an athletic skill.

Cancel claim 30.

31. (new): The device of claim 1, wherein said microprocessor is configured to store, in said memory, date information associated with the first time stamp information.

32. (new): The device of claim 1, wherein said microprocessor is configured to retrieve said first time stamp information from said real-time clock and associate the retrieved first time stamp information with said first user-defined event.

33. (new): The device of claim 32, wherein said microprocessor is configured to retrieve said first time stamp information from said real-time clock based on the detection of the user-defined event.

Cancel claim 34.

35. (new): The device of claim 1, wherein said memory is configured to continue to store said movement data in response to battery power being lost from said power source.

36. (new): The device of claim 1, wherein said movement sensor is configured to continuously check for said movement.

37. (new): The device of claim 36, wherein said microprocessor is configured to continuously interpret, based on the user-defined operational parameters, said movement data received from said movement sensor.

38. (new): The device of claim 1, wherein said output indicator is configured to display information signaling the occurrence of the first user-defined event based on the detection of the first user-defined event.

39. (new): The device of claim 38, wherein said output indicator is configured to display said information signaling the occurrence of the first user-defined event based on said first time stamp information.

40. (new): The device of claim 1, wherein said output indicator is configured to display information signaling the occurrence of the first user-defined event based on the detection of the first user-defined event and the first time stamp information.

41. (new): The device of claim 1, wherein said at least one of the user-defined operational parameters is a predetermined threshold, and said first user-defined event occurs when the movement data reaches the predetermined threshold.

42. (new): The device of claim 41, wherein said output indicator is configured to display information signaling the occurrence of the first user-defined event when the movement data reaches the predetermined threshold.

43. (new): The device of claim 41, wherein said memory is configured to store said first event information indicating that the predetermined threshold is met.

44. (new): The device of claim 43, wherein said memory is configured to store the first time stamp information in association with said first event information.

45. (new): The device of claim 1, wherein said output indicator is configured to indicate a low battery condition of the device.

46. (new): The device of claim 9, wherein said output indicator is selected from the group consisting of single monochromatic LEDs, multiple colored lights, and liquid crystal displays.

47. (new): The device of claim 1, wherein said movement data stored in the memory is configured to be downloaded to a computer.

48. (new): The device of claim 47, further comprising:

software configured to communicate with external software, wherein the external software is configured to present the downloaded movement data to the user.

49. (new): The device of claim 48, wherein said external software is configured to run on the computer.

50. (new): The device of claim 49, wherein said downloaded movement data is configured to be analyzed by said user via said external software.

51. (new): The device of claim 48, wherein said external software is configured to interpret said movement data and produce at least one report.

52. (new): The device of claim 48, wherein said external software is configured to interpret said movement data and produce at least one history report.

53. (new): The device of claim 52, wherein said at least one history report includes dates and times of said movement data.

54. (new): The device of claim 48, wherein said external software is configured to allow the user to program additional reports and histories with respect to said movement data of said user.

55. (new): The device of claim 47, wherein said movement data is configured to be downloaded to said computer via a wired connection.

56. (new): The device of claim 47, wherein said movement data is configured to be downloaded to said computer via a wireless connection.

Cancel claim 57.

58. (new): The device of claim 41, wherein the output indicator is configured to provide a visual indicator to the user regarding the predetermined threshold being reached.

Cancel claim 59.

60. (new): The device of claim 1, wherein the memory is configured to store the user-defined operational parameters, the user-defined operational parameters comprising a plurality of thresholds respectively corresponding to a plurality of notifications, wherein each time the movement data reaches one of the plurality of the thresholds, the microprocessor is configured to detect that one of the user-defined events occurred.

61. (new): The device of claim 60, wherein when the microprocessor detects that one of the user-defined events occurred based on the movement data reaching one of the plurality of the

thresholds, the output indicator displays a corresponding one of the notifications indicating that one of the user-defined events has occurred.

Cancel claim 62.

Cancel claim 63.

64. (new): The device of claim 60, wherein the plurality of thresholds are different from each other.

65. (new): The device of claim 60, wherein the plurality of notifications are different visual indicators.

66. (new): The device of claim 65, wherein at least one of the visual indicators includes a blinking indicator.

Cancel claim 67.

68. (new): The device of claim 41, wherein said microprocessor is configured to detect occurrence of the first user-defined event by comparing said movement data to said predetermined threshold.

69. (new): The device of claim 1, wherein said device is configured to be placed on said user's arm to monitor and record said movement data.

70. (new): The device of claim 69, wherein said movement sensor is configured to measure movement of said user's arm.

71. (new): The device of claim 1, wherein said movement sensor is configured to measure a walking distance.

72. (new): The device of claim 71, wherein said device is configured to be wearable by the user, and said movement sensor is configured to measure said walking distance of said user.

73. (new): The device of claim 1, wherein said microprocessor is configured to store, in said memory, date information associated with the first time stamp information,

wherein said movement sensor is configured to continuously check for said movement, wherein said output indicator is configured to display information signaling the occurrence of the first user-defined event based on the detection of the first user-defined event and the first time stamp information,

wherein the device further comprises software configured to communicate with external software configured to run on a computer and present the downloaded movement data,

wherein said external software is configured to produce at least one report based on said movement data.

wherein the memory is configured to store the user-defined operational parameters, the user-defined operational parameters comprising a plurality of thresholds respectively corresponding to a plurality of notifications, wherein each time the movement data reaches one of the plurality of the thresholds, the microprocessor is configured to detect that one of the user-defined events occurred,

wherein said device is configured to be placed on said user's arm to monitor and record said movement data,

wherein said movement sensor is configured to measure movement of said user's arm.

Cancel claim 74.

75. (new): The system of claim 13, wherein said microprocessor is configured to store, in said memory, date information associated with the first time stamp information.

76. (new): The system of claim 13, wherein said microprocessor is configured to retrieve said first time stamp information from said real-time clock and associate the retrieved first time stamp information with said first user-defined event.

77. (new): The system of claim 76, wherein said microprocessor is configured to retrieve said first time stamp information from said real-time clock based on the detection of the first user-defined event.

Cancel claim 78.

79. (new): The system of claim 13, wherein said memory is configured to continue to store said movement data in response to battery power being lost from said power source.

80. (new): The system of claim 13, wherein said movement sensor is configured to constantly checks for said movement.

81. (new): The system of claim 80, wherein said microprocessor is configured to continuously interpret, based on the user-defined operational parameters, said movement data received from said movement sensor.

82. (new): The system of claim 13, wherein said output indicator is configured to display information signaling the occurrence of the first user-defined event based on the detection of the first user-defined event.

83. (new): The system of claim 82, wherein said output indicator is configured to display said information signaling the occurrence of the first user-defined event based on said first time stamp information.

84. (new): The system of claim 13, wherein said output indicator is configured to display information signaling the occurrence of the first user-defined event based on the detection of the first user-defined event and the first time stamp information.

85. (new): The system of claim 13, wherein said at least one of the user-defined operational parameters is a predetermined threshold, and said first user-defined event occurs when the movement data reaches the predetermined threshold.

86. (new): The system of claim 85, wherein said output indicator is configured to display information signaling the occurrence of the first user-defined event when the movement data reaches the predetermined threshold.

87. (new): The system of claim 85, wherein said memory is configured to store said first event information indicating that the predetermined threshold is met.

88. (new): The system of claim 87, wherein said memory is configured to store the first time stamp information in association with said first event information.

89. (new): The system of claim 13, wherein said output indicator is configured to indicate a low battery condition of the device.

90. (new): The system of claim 13, wherein said output indicator is visual, and said output indicator is selected from the group consisting of single monochromatic LEDs, multiple colored lights, and liquid crystal displays.

91. (new): The system of claim 13, wherein said movement data stored in the memory is configured to be downloaded to the computer.

92. (new): The system of claim 91, wherein the portable, self-contained movement measuring device further comprises:

software configured to communicate with the program running on the computer, wherein the program is configured to present the downloaded movement data to the user.

93. (new): The system of claim 92, wherein said downloaded movement data is configured to be analyzed by said user via said program.

94. (new): The system of claim 92, wherein said program is configured to interpret said movement data and produce at least one report.

95. (new): The system of claim 92, wherein said program is configured to interpret said movement data and produce at least one history report.

96. (new): The system of claim 95, wherein said at least one history report includes dates and times of said movement data.

97. (new): The system of claim 92, wherein said program is configured to allow the user to program additional reports and histories with respect to said movement data of said user.

98. (new): The system of claim 91, wherein said movement data is configured to be downloaded to said computer, using the download device, via a wired connection.

99. (new): The system of claim 91, wherein said movement data is configured to be downloaded to said computer, using the download device, via a wireless connection.

Cancel claim 100.

101. (new): The system of claim 85, wherein the output indicator is configured to provide a visual indicator to the user regarding the predetermined threshold being reached.

Cancel claim 102.

103. (new): The system of claim 13, wherein the memory is configured to store the user-defined operational parameters, the user-defined operational parameters comprising a plurality of thresholds respectively corresponding to a plurality of notifications, wherein each time the

movement data reaches one of the plurality of the thresholds, the microprocessor is configured to detect that one of a plurality of user-defined events occurred.

104. (new): The system of claim 103, wherein when the microprocessor detects that one of the user-defined events occurred based on the movement data reaching one of the plurality of the thresholds, the output indicator displays a corresponding one of the notifications indicating that one of the user-defined events has occurred.

Cancel claim 105.

Cancel claim 106.

107. (new): The system of claim 103, wherein the plurality of thresholds are different from each other.

108. (new): The system of claim 103, wherein the plurality of notifications are different visual indicators.

109. (new): The system of claim 108, wherein at least one of the visual indicators includes a blinking indicator.

110. (new): The system of claim 13, wherein said output indicator is configured to signal the occurrence of user-defined events.

111. (new): The system of claim 85, wherein said microprocessor is configured to detect occurrence of the first user-defined event by comparing said movement data to said predetermined threshold.

112. (new): The system of claim 13, wherein said device is configured to be placed on said user's arm to monitor and record said movement data.

113. (new): The system of claim 112, wherein said movement sensor configured to measure movement of said user's arm.

114. (new): The system of claim 13, wherein said movement sensor configured to measure a walking distance.

115. (new): The system of claim 114, wherein said device is configured to be wearable by the user, and said movement sensor is configured to measure said walking distance of said user.

116. (new): The system of claim 13, wherein said microprocessor is configured to store, in said memory, date information associated with the first time stamp information,

wherein said movement sensor is configured to continuously check for said movement,
wherein said output indicator is configured to display information signaling the
occurrence of the first user-defined event based on the detection of the first user-defined event
and the first time stamp information,

wherein said movement data stored in the memory is configured to be downloaded to the
computer,

wherein the device further comprises software configured to communicate with the
program which presents the downloaded movement data,

wherein said program is configured to produce at least one report based on said
movement data,

wherein the memory is configured to store the user-defined operational parameters, the
user-defined operational parameters comprising a plurality of thresholds respectively
corresponding to a plurality of notifications, wherein each time the movement data reaches one
of the plurality of the thresholds, the microprocessor is configured to detect that one of the user-
defined events occurred,

wherein said device is configured to be placed on said user's arm to monitor and record
said movement data,

wherein said movement sensor configured to measure movement of said user's arm.

Cancel claim 117.

118. (new): The method of claim 20, further comprising:

storing, in said memory, date information associated with the first time stamp information.

119. (new): The method of claim 20, further comprising:
retrieving said first time stamp information from said real-time clock and associate the retrieved first time stamp information with said first user-defined event.

120. (new): The method of claim 119, further comprising:
retrieving said first time stamp information from said real-time clock based on the detection of the first user-defined event.

Cancel claim 121.

122. (new): The method of claim 20, wherein said storing comprises continuously storing said movement data after battery power is lost from a power source of the portable, self-contained movement measuring device.

123. (new): The method of claim 20, further comprising:
continuously monitoring for said physical movement using a movement sensor of the portable, self-contained movement measuring device.

124. (new): The method of claim 123, wherein said interpreting comprises:

continuously interpreting, based on the user-defined operational parameters, said physical movement data.

125. (new): The method of claim 20, further comprising:
displaying, using an output indicator of the portable, self-contained movement measuring device, information signaling the occurrence of the first user-defined event based on the detection of the user-defined event.

126. (new): The method of claim 125, wherein said output indicator displays said information signaling the occurrence of the first user-defined event based on said first time stamp information.

127. (new): The method of claim 20, further comprising:
displaying, using an output indicator included the portable, self-contained movement measuring device, information signaling the occurrence of the first user-defined event based on the detection of the first user-defined event and the first time stamp information.

128. (new): The method of claim 20, wherein said at least one of the user-defined operational parameters is a predetermined threshold, and said first user-defined event occurs when the movement data reaches the predetermined threshold.

129. (new): The method of claim 128, wherein an output indicator of the portable, self-contained movement measuring device displays information signaling the occurrence of the first user-defined event when the movement data reaches the predetermined threshold.

130. (new): The method of claim 128, further comprising:
storing, in said memory, said first event information indicating that the predetermined threshold is met.

131. (new): The method of claim 130, further comprising:
storing, in said memory, the first time stamp information in association with said first event information.

132. (new): The method of claim 20, further comprising:
indicating a low battery condition, using an output indicator of the portable, self-contained movement measuring device.

133. (new): The method of claim 20, wherein said physical movement data stored in the memory is the interpreted physical movement data, and said stored physical movement data is configured to be downloaded to a computer.

134. (new): The method of claim 133, further comprising:

communicating with external software, wherein the external software is configured to present said interpreted physical movement data to the user.

135. (new): The method of claim 134, wherein said external software is configured to run on a computer.

136. (new): The method of 20, further comprising:
producing a report based on said interpreted physical movement data.

137. (new): The method of 134, further comprising:
producing at least one report based on said interpreted physical movement data using the external software.

138. (new): The method of claim 134, further comprising:
producing at least one history report based on said interpreted physical movement data using the external software.

139. (new): The method of claim 138, wherein said at least one history report includes dates and times of said physical movement data.

140. (new): The method of claim 134, further comprising:

providing additional reports and histories with respect to said interpreted physical movement data, wherein the additional reports and histories are programmed by the user via the external software.

141. (new): The method of claim 133, wherein said physical movement data is configured to be downloaded to said computer via a wired connection.

142. (new): The method of claim 133, wherein said movement data is configured to be downloaded to the computer via a wireless connection.

Cancel claim 143.

144. (new): The method of claim 128, further comprising:
providing, via an output indicator of the portable, self-contained movement measuring device, a visual indicator to the user regarding the predetermined threshold being reached.

Cancel claim 145.

146. (new): The method of claim 20, further comprising:
storing the user-defined operational parameters, the user-defined operational parameters comprising a plurality of thresholds respectively corresponding to a plurality of notifications,

wherein the detecting comprises detecting occurrence of one of a plurality of user-defined events each time the movement data reaches one of the plurality of the thresholds.

147. (new): The method of claim 146, wherein in response to detecting that one of the user-defined events occurred based on the movement data reaching one of the plurality of the thresholds, the method further comprises:

displaying, via an output indicator of the portable, self-contained movement measuring device, a corresponding one of the notifications indicating that one of the user-defined events has occurred.

Cancel claim 148.

Cancel claim 149.

150. (new): The method of claim 146, wherein the plurality of thresholds are different from each other.

151. (new): The method of claim 146, wherein the plurality of notifications are different visual indicators.

152. (new): The method of claim 151, wherein at least one of the visual indicators includes a blinking indicator.

153. (new): The method of claim 20, further comprising:
signaling, using an output indicator included in the portable, self-contained movement
measuring device, the occurrence of user-defined events.

154. (new): The method of claim 128, wherein the detecting comprises comparing said
physical movement data to said predetermined threshold.

155. (new): The method of claim 20, wherein said body part is a user's arm, and said
measuring the data comprises monitoring and recording the physical movement of said user's
arm.

156. (new): The method of claim 155, wherein said measuring the data comprises
measuring the data using a movement sensor of the portable, self-contained movement
measuring device.

157. (new): The method of claim 20, further comprising:
measuring a walking distance based on the interpreted physical movement data.

158. (new): The method of claim 20, further comprising:
storing, in said memory, date information associated with the first time stamp
information;

continuously monitoring for said physical movement using a movement sensor of the portable, self-contained movement measuring device;

displaying, using an output indicator included the portable, self-contained movement measuring device, information signaling the occurrence of the first user-defined event based on the detection of the first user-defined event and the first time stamp information,

wherein said physical movement data stored in the memory is the interpreted physical movement data, and said stored physical movement data is configured to be downloaded to a computer;

communicating with external software configured to run on the computer and present said interpreted physical movement data to the user;

producing a report based on said interpreted physical movement data using the external software; and

storing the user-defined operational parameters, the user-defined operational parameters comprising a plurality of thresholds respectively corresponding to a plurality of notifications, wherein the detecting comprises detecting occurrence of one of a plurality of user-defined events each time the movement data reaches one of the plurality of the thresholds,

wherein said body part is a user's arm, and said measuring the data comprises monitoring and recording the physical movement of said user's arm.

159. (new): The device of claim 1, wherein the user-defined operational parameters comprise a first predetermined threshold and a second predetermined threshold different from the first predetermined threshold,

wherein the first user-defined event occurs when the movement data reaches the first predetermined threshold and a second user-defined event occurs when the movement data reaches the second predetermined threshold,

wherein said microprocessor is configured to interpret said movement data to determine whether the movement data reaches the first predetermined threshold and whether the movement data reaches the second predetermined threshold.

160. (new): The device of claim 159, wherein the output indicator is configured to display first information indicating occurrence of the first user-defined event when it is determined that the first predetermined threshold is met, and configured to display second information indicating occurrence of the second user-defined event when it is determined that the second predetermined threshold is met.

161. (new): The device of claim 160, wherein the displayed first information is different from the displayed second information.

162. (new): The device of claim 1, wherein the first user-defined event is a movement exceeding a user-defined angle limit and the first time stamp information reflects a time at which the movement exceeded the user-defined angle limit.

163. (new): The device of claim 1, wherein said first user-defined event is a predetermined type of movement.

164. (new): The device of claim 163, wherein the predetermined type of movement is movement exceeding a predetermined angle limit.

165. (new): The device of claim 163, wherein the predetermined type of movement is movement exceeding a predefined speed.

166. (new): The device of claim 163, wherein the predetermined type of movement is no movement for a predetermined amount of time.

167. (new): The device of claim 163, wherein the predetermined type of movement is a maximum number of incorrect movements allowed in a predetermined time period.

168. (new): The device of claim 1, wherein said microprocessor is configured to detect a second event based on the movement data and at least one of the user-defined operational parameters, and said microprocessor is configured to store, in said memory, second event information related to the detected second event along with second time stamp information reflecting a time at which the movement data causing the second event occurred.

169. (new): The device of claim 168, wherein said second event is a predetermined type of movement.

170. (new): The device of claim 169, wherein the predetermined type of movement is movement exceeding a predetermined angle limit.

171. (new): The device of claim 169, wherein the predetermined type of movement is movement exceeding a predefined speed.

172. (new): The device of claim 169, wherein the predetermined type of movement is no movement for a predetermined amount of time.

173. (new): The device of claim 169, wherein the predetermined type of movement is a maximum number of incorrect movements allowed in a predetermined time period.

174. (new): The system of claim 13, wherein the user-defined operational parameters comprise a first predetermined threshold and a second predetermined threshold different from the first predetermined threshold,

wherein the first user-defined event occurs when the movement data reaches the first predetermined threshold and a second user-defined event occurs when the movement data reaches the second predetermined threshold,

wherein said microprocessor is configured to interpret said movement data to determine whether the movement data reaches the first predetermined threshold and whether the movement data reaches the second predetermined threshold.

175. (new): The system of claim 174, wherein the output indicator is configured to display first information indicating occurrence of the first user-defined event when it is determined that the first predetermined threshold is met, and configured to display second information indicating occurrence of the second user-defined event when it is determined that the second predetermined threshold is met.

176. (new): The system of claim 175, wherein the displayed first information is different from the displayed second information.

177. (new): The system of claim 13, wherein the first user-defined event is a movement exceeding a user-defined angle limit and the first time stamp information reflects a time at which the movement exceeded the user-defined angle limit.

178. (new): The system of claim 13, wherein said first user-defined event is a predetermined type of movement.

179. (new): The system of claim 178, wherein the predetermined type of movement is movement exceeding a predetermined angle limit.

180. (new): The system of claim 178, wherein the predetermined type of movement is movement exceeding a predefined speed.

181. (new): The system of claim 178, wherein the predetermined type of movement is no movement for a predetermined amount of time.

182. (new): The system of claim 178, wherein the predetermined type of movement is a maximum number of incorrect movements allowed in a predetermined time period.

183. (new): The system of claim 13, wherein said microprocessor is configured to detect a second event based on the movement data and at least one of the user-defined operational parameters, and said microprocessor is configured to store, in said memory, second event information related to the detected second event along with second time stamp information reflecting a time at which the movement data causing the second event occurred.

184. (new): The system of claim 183, wherein said second event is a predetermined type of movement.

185. (new): The system of claim 184, wherein the predetermined type of movement is movement exceeding a predetermined angle limit.

186. (new): The system of claim 184, wherein the predetermined type of movement is movement exceeding a predefined speed.

187. (new): The system of claim 184, wherein the predetermined type of movement is no movement for a predetermined amount of time.

188. (new): The system of claim 184, wherein the predetermined type of movement is a maximum number of incorrect movements allowed in a predetermined time period.

189. (new): The system of claim 13, wherein said movement sensor comprises at least one accelerometer.

190. (new): The method of claim 20, wherein the user-defined operational parameters comprise a first predetermined threshold and a second predetermined threshold different from the first predetermined threshold,

wherein the first user-defined event occurs when the movement data reaches the first predetermined threshold and a second user-defined event occurs when the movement data reaches the second predetermined threshold,

wherein said interpreting comprises interpreting said movement data to determine whether the movement data reaches the first predetermined threshold and whether the movement data reaches the second predetermined threshold.

191. (new): The method of claim 190, further comprising:
displaying, using an output indicator included in the portable, self-contained movement measuring device, first information indicating occurrence of the first user-defined event when it

is determined that the first predetermined threshold is met and second information indicating occurrence of the second user-defined event when it is determined that the second predetermined threshold is met.

192. (new): The method of claim 191, wherein the displayed first information is different from the displayed second information.

193. (new): The method of claim 20, wherein the first user-defined event is a movement exceeding a user-defined angle limit and the first time stamp information reflects a time at which the movement exceeded the user-defined angle limit.

194. (new): The method of claim 20, wherein said first user-defined event is a predetermined type of movement.

195. (new): The method of claim 194, wherein the predetermined type of movement is movement exceeding a predetermined angle limit.

196. (new): The method of claim 194, wherein the predetermined type of movement is movement exceeding a predefined speed.

197. (new): The method of claim 194, wherein the predetermined type of movement is no movement for a predetermined amount of time.

198. (new): The method of claim 194, wherein the predetermined type of movement is a maximum number of incorrect movements allowed in a predetermined time period.

199. (new): The method of claim 20, further comprising:
detecting, using the microprocessor, a second event based on the movement data and at least one of the user-defined operational parameters; and
storing, in said memory, second event information related to the detected second event along with second time stamp information reflecting a time at which the movement data causing the second event occurred.

200. (new): The method of claim 199, wherein said second event is a predetermined type of movement.

201. (new): The method of claim 200, wherein the predetermined type of movement is movement exceeding a predetermined angle limit.

202. (new): The method of claim 200, wherein the predetermined type of movement is movement exceeding a predefined speed.

203. (new): The method of claim 200, wherein the predetermined type of movement is no movement for a predetermined amount of time.

RESPONSE TO *EX PARTE* REEXAMINATION FINAL OFFICE ACTION
Control No.: 90/013,201
Attorney Docket No.: A209779

204. (new): The method of claim 200, wherein the predetermined type of movement is a maximum number of incorrect movements allowed in a predetermined time period.

II. STATUS OF THE CLAIMS AND EXEMPLARY SUPPORT FOR CLAIM AMENDMENTS

Claim No.	Status	Support in Specification
1	Pending	col. 5, line 59 to col. 6, line 9
2	Pending	NA
3	Pending	NA
4	Pending	NA
5	Pending	NA
6	Pending	NA
7	Pending	NA
8	Pending	NA
9	Pending	NA
10	Pending	NA
11	Pending	NA
12	Pending	NA
13	Pending	col. 5, line 59 to col. 6, line 9
14	Pending	NA
15	Pending	NA
16	Pending	NA
17	Pending	NA
18	Pending	NA
19	Pending	NA
20	Pending	col. 5, line 59 to col. 6, line 9
21	Pending	NA
22	Pending	NA
23	Pending	NA
24	Pending	NA
25	Pending	NA
26	Pending	NA
27	Pending	NA
28	Pending	NA
29	Pending	NA
30	Canceled	NA
31	New	col. 6, lines 5-9
32	New	col. 5, line 44; col. 6, line 9
33	New	col. 5, line 44; col. 6, line 9
34	Canceled	NA
35	New	col. 5, lines 47-51
36	New	col. 5, lines 40-41
37	New	col. 6, lines 16-40

RESPONSE TO *EX PARTE* REEXAMINATION FINAL OFFICE ACTION

Control No.: 90/013,201

Attorney Docket No.: A209779

38	New	col. 4, lines 5-14 and col. 6, lines 6-15
39	New	col. 4, lines 5-14 and col. 6, lines 6-15
40	New	col. 4, lines 5-14 and col. 6, lines 6-15
41	New	col. 5, line 59 to col. 6, line 9 and col. 7, lines 6-30
42	New	col. 5, line 58 to col. 6, line 3 and col. 6, lines 41-43
43	New	col. 6, lines 6-9
44	New	col. 6, lines 6-9 and col. 6, lines 19-21
45	New	col. 6, lines 27-39
46	New	col. 5, lines 25-27
47	New	col. 8, lines 31-55
48	New	col. 8, lines 31-55
49	New	col. 8, lines 31-55
50	New	col. 8, lines 40-55
51	New	col. 8, lines 40-55
52	New	col. 8, lines 40-55
53	New	col. 8, lines 40-55
54	New	col. 8, lines 40-55
55	New	col. 8, lines 30-55
56	New	col. 8, lines 30-55
57	Canceled	NA
58	New	col. 4, lines 9-14
59	Canceled	NA
60	New	col. 5, line 58 to col. 6, line 15 and col. 7, lines 6-30
61	New	col. 5, line 58 to col. 6, line 15 and col. 7, lines 6-30
62	Canceled	NA
63	Canceled	NA
64	New	col. 5, line 58 to col. 6, line 15
65	New	col. 4, lines 5-14
66	New	col. 4, lines 5-14
67	Canceled	NA
68	New	col. 5, line 58 to col. 6, line 15 and col. 7, lines 6-30
69	New	col. 3, lines 59-62
70	New	col. 3, lines 59-62
71	New	col. 3, lines 45-47
72	New	col. 3, lines 45-47
73	New	col. 3, lines 59-62, col. 4, lines 5-14, col. 5, lines 40-41, col. 5, line 58 to col. 6, line 15, col. 7, lines 6-30, and col. 8, lines 30-55
74	Canceled	NA
75	New	col. 6, lines 5-9
76	New	col. 5, line 44; col. 6, line 9
77	New	col. 5, line 44; col. 6, line 9
78	Canceled	NA

RESPONSE TO *EX PARTE* REEXAMINATION FINAL OFFICE ACTION

Control No.: 90/013,201

Attorney Docket No.: A209779

79	New	col. 5, lines 47-51
80	New	col. 5, lines 40-41
81	New	col. 6, lines 16-40
82	New	col. 4, lines 5-14 and col. 6, lines 6-15
83	New	col. 4, lines 5-14 and col. 6, lines 6-15
84	New	col. 4, lines 5-14 and col. 6, lines 6-15
85	New	col. 5, line 59 to col. 6, line 9 and col. 7, lines 6-30
86	New	col. 5, line 58 to col. 6, line 3 and col. 6, lines 41-43
87	New	col. 6, lines 6-9
88	New	col. 6, lines 6-9 and col. 6, lines 19-21
89	New	col. 6, lines 27-39
90	New	col. 5, lines 25-27
91	New	col. 8, line 31-55
92	New	col. 8, line 31-55
93	New	col. 8, line 40-55
94	New	col. 8, line 40-55
95	New	col. 8, line 40-55
96	New	col. 8, line 40-55
97	New	col. 8, line 40-55
98	New	col. 8, line 30-45
99	New	col. 8, lines 30-55
100	Canceled	NA
101	New	col. 4, lines 9-14
102	Canceled	NA
103	New	col. 5, line 58 to col. 6, line 15 and col. 7, lines 6-30
104	New	col. 5, line 58 to col. 6, line 15 and col. 7, lines 6-30
105	Canceled	NA
106	Canceled	NA
107	New	col. 5, line 58 to col. 6, line 15
108	New	col. 4, lines 5-14
109	New	col. 4, lines 5-14
110	New	col. 4, lines 3-14
111	New	col. 5, line 58 to col. 6, line 15 and col. 7, lines 6-30
112	New	col. 3, lines 59-62
113	New	col. 3, lines 59-62
114	New	col. 3, lines 45-47
115	New	col. 3, lines 45-47
116	New	col. 3, lines 59-62, col. 4, lines 5-14, col. 5, lines 40-41, col. 5, line 58 to col. 6, line 15, col. 7, lines 6-30, and col. 8, lines 30-55
117	Canceled	NA
118	New	col. 6, lines 5-9
119	New	col. 5, line 44; col. 6, line 9

RESPONSE TO *EX PARTE* REEXAMINATION FINAL OFFICE ACTION

Control No.: 90/013,201

Attorney Docket No.: A209779

120	New	col. 5, line 44; col. 6, line 9
121	Canceled	NA
122	New	col. 5, lines 47-51
123	New	col. 5, lines 40-41
124	New	col. 6, lines 16-40
125	New	col. 4, lines 5-14 and col. 6, lines 6-15
126	New	col. 4, lines 5-14 and col. 6, lines 6-15
127	New	col. 4, lines 5-14 and col. 6, lines 6-15
128	New	col. 5, line 59 to col. 6, line 9 and col. 7, lines 6-30
129	New	col. 5, line 58 to col. 6, line 3 and col. 6, lines 41-43
130	New	col. 6, lines 6-9
131	New	col. 6, lines 6-9 and col. 6, lines 19-21
132	New	col. 6, lines 27-39
133	New	col. 8, line 31-55
134	New	col. 8, line 31-55
135	New	col. 8, line 31-55
136	New	col. 8, line 40-55
137	New	col. 8, line 40-55
138	New	col. 8, line 40-55
139	New	col. 8, line 40-55
140	New	col. 8, line 40-55
141	New	col. 8, line 30-45
142	New	col. 8, line 30-45
143	Canceled	NA
144	New	col. 4, lines 9-14
145	Canceled	NA
146	New	col. 5, line 58 to col. 6, line 15 and col. 7, lines 6-30
147	New	col. 5, line 58 to col. 6, line 15 and col. 7, lines 6-30
148	Canceled	NA
149	Canceled	NA
150	New	col. 5, line 58 to col. 6, line 15
151	New	col. 4, lines 5-14
152	New	col. 4, lines 5-14
153	New	col. 4, lines 3-14
154	New	col. 5, line 58 to col. 6, line 15 and col. 7, lines 6-30
155	New	col. 3, lines 59-62
156	New	col. 4, lines 38-45
157	New	col. 3, lines 45-47
158	New	col. 3, lines 59-62, col. 4, lines 5-14, col. 5, lines 40-41, col. 5, line 58 to col. 6, line 15, col. 7, lines 6-30, and col. 8, lines 30-55
159	New	col. 5, line 58 to col. 6, line 40 and col. 7, lines 6-30
160	New	col. 4, lines 5-14

RESPONSE TO *EX PARTE* REEXAMINATION FINAL OFFICE ACTION

Control No.: 90/013,201

Attorney Docket No.: A209779

161	New	col. 4, lines 5-14
162	New	col. 5, line 59 to col. 6, line 15
163	New	col. 6, lines 16-40 and col. 10, lines 50-54
164	New	col. 6, lines 19-26
165	New	col. 6, lines 19-40
166	New	col. 6, lines 19-40
167	New	paragraph bridging cols. 7-8
168	New	col. 5, line 59 to col. 6, line 9, and col. 7, lines 6-30
169	New	col. 6, lines 16-40 and col. 10, lines 50-54
170	New	col. 6, lines 19-26
171	New	col. 6, lines 19-40
172	New	col. 6, lines 19-40
173	New	paragraph bridging cols. 7-8
174	New	col. 5, line 58 to col. 6, line 40 and col. 7, lines 6-30
175	New	col. 4, lines 5-14
176	New	col. 4, lines 5-14
177	New	col. 5, line 59 to col. 6, line 15
178	New	col. 6, lines 16-40 and col. 10, lines 50-54
179	New	col. 6, lines 19-26
180	New	col. 6, lines 19-40
181	New	col. 6, lines 19-40
182	New	paragraph bridging cols. 7-8
183	New	col. 5, line 59 to col. 6, line 9, and col. 7, lines 6-30
184	New	col. 6, lines 16-40 and col. 10, lines 50-54
185	New	col. 6, lines 19-26
186	New	col. 6, lines 19-40
187	New	col. 6, lines 19-40
188	New	paragraph bridging cols. 7-8
189	New	col. 4, lines 38-45
190	New	col. 5, line 58 to col. 6, line 40 and col. 7, lines 6-30
191	New	col. 4, lines 5-14
192	New	col. 4, lines 5-14
193	New	col. 5, line 59 to col. 6, line 15
194	New	col. 6, lines 16-40 and col. 10, lines 50-54
195	New	col. 6, lines 19-26
196	New	col. 6, lines 19-40
197	New	col. 6, lines 19-40
198	New	paragraph bridging cols. 7-8
199	New	col. 5, line 59 to col. 6, line 9, and col. 7, lines 6-30
200	New	col. 6, lines 16-40 and col. 10, lines 50-54
201	New	col. 6, lines 19-26
202	New	col. 6, lines 19-40

RESPONSE TO *EX PARTE* REEXAMINATION FINAL OFFICE ACTION

Control No.: 90/013,201

Attorney Docket No.: A209779

203	New	col. 6, lines 19-40
204	New	paragraph bridging cols. 7-8

III. REMARKS

Claims 1, 13, 20, 21, 31-33, 35-56, 58, 60, 61, 64-66, 68-73, 75-77, 79-99, 101, 103, 104, 107-116, 118-120, 122-142, 144, 146, 147, and 150-204 are subject to reexamination. All the reexamined claims are rejected.

Claims 1, 13, and 20 are the independent claims.

By this Amendment, independent claims 1, 13, and 20 along with dependent claims 168, 183, and 199 have been amended.

Patentable claims

PO thanks the Examiner for confirming the patentability of claims 162, 164-167, 170-173, 177, 179-182, 185-188, 193, 195-198, and 201-204.

PO respectfully requests the Examiner to confirm the patentability of independent claims 1, 13, and 20 along with the remaining dependent claims in view of the claim amendments being made herein and the corresponding arguments submitted below.

Summary of claim amendments and response

As an initial matter, Patent Owner's (PO's) representatives would again like to thank Examiners Danton De Mille along with Eileen Lillis and Jimmy Foster for the courtesies extended during the personal interview conducted on December 18, 2014 (*see* Examiner's Interview Summary dated December 22, 2014 and Statement of Substance of Interview filed January 8, 2015).

During the interview, proposed clarifying amendments to independent claims 1, 13, and 20 were discussed in light of the Examiner's comments in the Office Action dated December 10, 2014. Further, differences between the claimed invention and the cited references were discussed in view of the proposed amendments to the claims.

In particular, clarifying amendments were discussed during the interview to tie the claimed first time stamp information such that it reflects a time at which the movement data causing the first user-defined event occurred.

Accordingly, along the lines of the discussion during the interview, independent claims 1, 13, and 20 have been amended to recite in some variation:

the microprocessor storing first event information related to the detected first user-defined event along with first time stamp information reflecting a time at which the movement data causing the first user-defined event occurred

For instance, upon detection of the event, such as when a user's measured movement passes a given angle (or some other type of movement threshold), time stamp information is recorded. This recorded time stamp information reflects a time at which the user's movement (e.g., passing the given angle) caused the event to occur (patent specification, col. 6, lines 15-40 *also see* col. 7, lines 32-43).

As discussed during the interview and explained below, the asserted combination of references (i.e., Flentov/Gaudet/Vock with Burdea) does not teach or suggest this feature.

For example, the alleged time stamp information in the Examiner's proposed combination of Flentov and Burdea would reflect the time at which the data captured during the skier's run down the hill (i.e., at the end of the session) is updated to a database, not a time at which the movement data causing the end of the run (alleged event) occurred.

The rejections based on Gaudet and Vock are similarly deficient, as explained below.

Dependent claims 168, 183, and 199 have been amended so they are consistent with the amendments made to independent claims 1, 13, and 20.

Accordingly, as discussed in further detail below, the instant Response places the claims in condition for immediate allowance. Consequently, PO respectfully requests the Examiner to issue a Notice of Intent to Issue *Ex Parte* Reexamination Certificate responsive to this Response.

Claim Rejections - 35 USC §103

Claims 1, 13, 20, 21, 31-33, 35-56, 58, 60, 61, 64-66, 68-73, 75-77, 79-99, 101, 103, 104, 107-116, 118-120, 122-142, 144, 146, 147, 150-161, 163, 168, 169, 174-176, 178, 183, 184, 189-192, 194, 199, and 200 are rejected under pre-AIA 35 U.S.C. 103(a) as allegedly being unpatentable over Flentov in view of Burdea.

Claims 20, 118-120, 123-142, 144, 153, 154, 157, 194, 199, and 200 are rejected under pre-AIA 35 U.S.C. 103(a) as allegedly being unpatentable over Gaudet in view of Burdea¹.

Claim 122 is rejected under pre-AIA 35 U.S.C. 103(a) as allegedly being unpatentable over Gaudet and Burdea, and further in view of Flentov.

Claims 1, 13, 20, 21, 31-33, 35-56, 58, 60, 61, 64-66, 68-73, 75-77, 79-99, 101, 103, 104, 107-116, 118-120, 122-142, 144, 146, 147, 150-161, 163, 168, 169, 174-176, 178, 183, 184, 189-192, 194, 199, and 200 are rejected under pre-AIA 35 U.S.C. 103(a) as allegedly being unpatentable over Vock in view of Burdea.

¹ Even though claim 122 is listed in the statement of rejection at page 29 of the Office Action, this claim is separately rejected at page 35.

For *at least* the following reasons, PO respectfully traverses these rejections.

As noted above, independent claims 1, 13, and 20 have been amended to recite, in some variation:

the microprocessor capable of...detecting a first user-defined event based on the movement data and at least one of the user-defined operational parameters, and storing first event information related to the detected first user-defined event along with first time stamp information reflecting a time at which the movement data causing the first user-defined event occurred;

As such, in the claimed invention, **the microprocessor detects the first user-defined event based on two pieces of information - the movement data** and the user-defined operational parameter. The first time stamp information **reflects a time at which the movement data causing the first user-defined event occurred**

It is respectfully submitted that the asserted combinations of the references do not teach or suggest the above-noted claim features.

Flentov and Burdea do not teach the subject claim features of independent claims 1, 13, and 20

First, in Flentov, the alleged detection of an event is not made by a microprocessor based on any movement data.

For example, in the Office Action, it is asserted that the alleged event in Flentov occurs when the user (skier) pushes a button 58 instructing the system to stop recording movement data (Office Action, paragraph bridging pages 7-8).

That is, the detection of the alleged event is solely based on the button 58 being pushed and *not based on any movement data*, let alone **a microprocessor** making the detection based on such movement data.

In particular, regardless of how long or short the run, the event is detected based on the user pushing the button 58 - the movement data of the run does not at all factor into the detection of the event. Moreover, the microprocessor does not detect the event. All that matters is when the user pushes the button.

During the interview, the Examiner seemed to suggest that the event in Flentov is detected based on the movement data apparently because the skier pushes the button 58 when the user's movement ends.

PO respectfully submits that even if Flentov is interpreted this way, it still does not teach the claimed detection operation because the Examiner is overlooking the fact that the claims require **the microprocessor** to detect a first user-defined event **based on the movement data** and at least one of the user-defined operational parameters.

That is, the event is detected by the microprocessor based on the movement data, not the user. On the other hand, in Flentov, even assuming *arguendo* that the skier's movement data is taken into account for detecting the end of the run, the movement data is taken into account by the user, not the microprocessor as claimed.

Therefore, Flentov does not and cannot teach the claimed microprocessor...detecting a first user-defined event based on the movement data and at least one of the user-defined operational parameters.

Second, Flentov alone or in combination with Burdea does not teach or suggest the claimed microprocessor capable of...storing first event information related to the detected first user-defined event along with first time stamp information reflecting a time at which the movement data causing the first user-defined event occurred.

As discussed during the interview, the alleged time stamp information in the Examiner's proposed combination of Flentov and Burdea would reflect the time at which the data captured during the skier's run down the hill (i.e., at the end of the session) is updated to a database, ***not a time at which the movement data causing the end of the run*** (alleged event) **occurred**.

In particular, as noted above, the alleged event in Flentov is detected when the skier pushes the button 58 instructing the system to stop recording movement data (e.g., at the end of a run down a hill).

Burdea, which is relied upon for allegedly teaching the claimed first time stamp information, discloses that "[p]atient data can be stored in database 114 for statistical purposes. Database 114 can include a time stamp for providing a time history of updates of the patient information" (Burdea, col. 6, lines 30-33). **That is, the time stamp described in Burdea is related to the update time at which the patient data is updated at the database 114.**

As such, if Burdea's teachings are incorporated into Flentov, then the proposed modification with Burdea would result in the ski data being downloaded by the skier to a computer along with a time stamp indicating the time at which the ski data was downloaded.

Since the time stamp in the proposed modification reflects the time at which the ski data was downloaded, this could occur shortly after the skier pushes the button or a day or two later.

Regardless of when the ski data is downloaded, the time stamp information in the proposed modification has no relationship to the ski data itself or the time at which the skier pushes the button (i.e., the Examiner's proposed event). Therefore, the proposed modification is substantially different from the invention as now claimed.

In view of the foregoing, it is respectfully submitted that Flentov alone, or in combination with Burdea, does not and cannot teach all the features of independent claims 1, 13, and 20.

PO respectfully submits that the remaining claims, namely claims 21, 31-33, 35-56, 58, 60, 61, 64-66, 68-73, 75-77, 79-99, 101, 103, 104, 107-116, 118-120, 122-142, 144, 146, 147, 150-161, 163, 168, 169, 174-176, 178, 183, 184, 189-192, 194, 199, and 200, are patentable over Flentov and Burdea *at least* by virtue of their dependency.

Gaudet and Burdea do not teach the subject claim features of independent claim 20

First, similar to Flentov, Gaudet does not teach detecting an event based on movement data as required by claim 20.

As the Examiner notes, Gaudet teaches detecting occurrence of positive/negative spike events based on which foot contact times can be measured (the foot contact time is measured as the time difference between each instance at which the foot impacts the surface and the following instance at which the foot leaves the surface) (Office Action, page 30 along with Gaudet, col. 2, lines 5-26 and col. 4, line 50 to col. 5, line 5).

Further, as noted by the Examiner, Gaudet discloses that certain parameters used in its software routine can be user-adjustable and this could be accomplished by “pushing of a button

both when the user starts and when the user finishes traversing a known distance” (Office Action, pages 29-30 and Gaudet, col. 16, lines 60-64).

As such, the alleged detection of an event in Gaudet is similar to the alleged detection of an event in Flentov. That is, the event detection in Gaudet is *not based on the movement data* but based on the user input alone.

For *at least* this reason, claim 20 is patentable over Gaudet and Burdea.

Moreover, the asserted combination of Gaudet and Burdea cannot and does not teach the claimed microprocessor which stores first event information related to the detected first user-defined event along with first time stamp information **reflecting a time at which the movement data causing the first user-defined event occurred.**

It is generally alleged in the Office Action that “[i]t would have been obvious to one of ordinary skill in the art to modify the timer of Gaudet to provide a time/date stamp as taught by Burdea to be associated **with the movement data** in order to maintain a time history of user information for statistical purposes” (Office Action, page 31, third paragraph, emphasis added).

However, similar to the flawed combination of Burdea with Flentov, if Burdea’s teachings are incorporated into Gaudet, then the proposed modification with Burdea would result in the user’s movement data captured during the “known distance” (session) traversed by the user (until the user pushes the button at the end) to be stored in a database at the end of the session along with a time stamp indicating the time at which the database was updated.

Since the time stamp in the proposed modification reflects the time at which the movement data captured during the “known distance” was stored in a database, this could occur shortly after the user pushes the button at the end of the session or a day or two later.

Consequently, the time stamp information in Gaudet would not reflect a time at which certain movement data causing the event occurred but would instead reflect a time at which the movement data captured during the entire session is updated to a database.

On the other hand, in the claimed invention, the first time stamp information **reflects the time at which the movement data causing the first user-defined event occurred.**

In view of the foregoing, it is respectfully submitted that Gaudet alone, or in combination with Burdea, does not and cannot teach all the features of independent claim 20.

PO respectfully submits that the remaining claims, namely claims 118-120, 123-142, 144, 153, 154, 157, 194, 199, and 200, are patentable over Gaudet and Burdea *at least* by virtue of their dependency.

Claim 122 depends from claim 20 and Flentov does not cure the above-noted deficient teachings of Gaudet and Burdea with respect to claim 20. Accordingly, claim 122 is patentable *at least* by virtue of its dependency.

Vock and Budea do not teach the subject claim features of independent claims 1, 13, and 20

Independent claims 1, 13, and 20 are patentable over the asserted combination of Vock and Burdea for *at least* reasons similar to those given above with respect to the rejection based on the asserted combination of Flentov and Burdea.

The Vock patent matured from a continuation-in-part application of the Flentov patent.

The Examiner relies on similar portions of Vock and Flentov for allegedly teaching the claimed microprocessor detecting an event and storing time stamp information reflecting a time at which movement data causing the event occurred.

For example, at pages 39-40, the Examiner cites Vock's teachings of a user pressing the start/stop button 58 to signal the end of a run (e.g., down a hill) as corresponding to the claimed event detection. Then, reasoning similar to that provided for combining Flentov and Burdea is provided for combining Vock and Burdea. *Id.*

As already noted above with respect to the asserted combination of Flentov and Burdea, the combined teachings of these references cannot and do not teach or suggest the claimed **microprocessor** capable of...detecting a first user-defined event **based on the movement data** and at least one of the user-defined operational parameters, and storing first event information related to the detected first user-defined event along with first time stamp information **reflecting a time at which the movement data causing the first user-defined event occurred.**

Therefore, for *at least* reasons similar to those given above with respect to the rejection based on the asserted combination of Flentov and Burdea, it is respectfully submitted that Vock alone, or in combination with Burdea, does not and cannot teach all the features of independent claims 1, 13, and 20.

PO respectfully submits that the remaining claims, namely claims 21, 31-33, 35-56, 58, 60, 61, 64-66, 68-73, 75-77, 79-99, 101, 103, 104, 107-116, 118-120, 122-142, 144, 146, 147, 150-161, 163, 168, 169, 174-176, 178, 183, 184, 189-192, 194, 199, and 200, are patentable over Vock and Burdea *at least* by virtue of their dependency.

RESPONSE TO *EX PARTE* REEXAMINATION FINAL OFFICE ACTION
Control No.: 90/013,201
Attorney Docket No.: A209779

Conclusion

In view of the above, reconsideration and issuance of a Notice of Intent to Issue *Ex Parte* Reexamination Certificate in this proceeding are now believed to be in order, and such actions are hereby solicited. If any points remain in issue which the Examiner feels may be best resolved through a personal or telephone interview, the Examiner is kindly requested to contact the undersigned at the telephone number listed below.

The USPTO is directed and authorized to charge all required fees, except for the Issue Fee and the Publication Fee, to Deposit Account No. 19-4880. Please also credit any overpayments to said Deposit Account.

Respectfully submitted,

/Abdul-Quadeer Ahmed/

SUGHRUE MION, PLLC
Telephone: 202.293.7060
Facsimile: 202.293.7860

WASHINGTON OFFICE

23373

CUSTOMER NUMBER

Date: January 9, 2015

Quadeer A. Ahmed
Registration No. 60,835

Electronic Acknowledgement Receipt

EFS ID:	21173061
Application Number:	90013201
International Application Number:	
Confirmation Number:	9930
Title of Invention:	TRAINING AND SAFETY DEVICE, SYSTEM AND METHOD TO AID IN PROPER MOVEMENT DURING PHYSICAL ACTIVITY
First Named Inventor/Applicant Name:	6059576
Customer Number:	23373
Filer:	Quadeer A. Ahmed/Shanele Jones
Filer Authorized By:	Quadeer A. Ahmed
Attorney Docket Number:	A209779
Receipt Date:	09-JAN-2015
Filing Date:	04-APR-2014
Time Stamp:	16:43:43
Application Type:	Reexam (Patent Owner)

Payment information:

Submitted with Payment	no
------------------------	----

File Listing:

Document Number	Document Description	File Name	File Size(Bytes)/ Message Digest	Multi Part /.zip	Pages (if appl.)
1		A209779ResponsetoFOAasfiled.pdf	204734 7d0ebef846b213b6e948536f10ef77dcc6a4363	yes	57

Multipart Description/PDF files in .zip description		
Document Description	Start	End
Reexam Response to Final Rejection	1	1
Claims	2	46
Applicant Arguments/Remarks Made in an Amendment	47	57

Warnings:

Information:

Total Files Size (in bytes):	204734
-------------------------------------	--------

This Acknowledgement Receipt evidences receipt on the noted date by the USPTO of the indicated documents, characterized by the applicant, and including page counts, where applicable. It serves as evidence of receipt similar to a Post Card, as described in MPEP 503.

New Applications Under 35 U.S.C. 111

If a new application is being filed and the application includes the necessary components for a filing date (see 37 CFR 1.53(b)-(d) and MPEP 506), a Filing Receipt (37 CFR 1.54) will be issued in due course and the date shown on this Acknowledgement Receipt will establish the filing date of the application.

National Stage of an International Application under 35 U.S.C. 371

If a timely submission to enter the national stage of an international application is compliant with the conditions of 35 U.S.C. 371 and other applicable requirements a Form PCT/DO/EO/903 indicating acceptance of the application as a national stage submission under 35 U.S.C. 371 will be issued in addition to the Filing Receipt, in due course.

New International Application Filed with the USPTO as a Receiving Office

If a new international application is being filed and the international application includes the necessary components for an international filing date (see PCT Article 11 and MPEP 1810), a Notification of the International Application Number and of the International Filing Date (Form PCT/RO/105) will be issued in due course, subject to prescriptions concerning national security, and the date shown on this Acknowledgement Receipt will establish the international filing date of the application.

PATENT APPLICATION

IN THE UNITED STATES PATENT AND TRADEMARK OFFICE

In re Patent of

Docket No: A209779

Theodore L. Brann

Control No.: 90/013,201

Group Art Unit: 3993

Confirmation No.: 9930

Examiner: DEMILLE, DANTON D

Filed: April 4, 2014

For: TRAINING AND SAFETY DEVICE, SYSTEM AND METHOD TO AID IN PROPER
MOVEMENT DURING PHYSICAL ACTIVITY

STATEMENT OF SUBSTANCE OF INTERVIEW

Commissioner for Patents
P.O. Box 1450
Alexandria, VA 22313-1450

Sir:

Please review and enter the following remarks summarizing the personal interview conducted on December 18, 2014.

As an initial matter, Patent Owner's representatives thank the Examiners for the courtesies extended during the personal interview.

During the interview, proposed clarifying amendment to independent claims 1, 13, and 20 were discussed in light of the Examiner's comments in the Office Action dated December 10, 2014. Further, differences between the claimed invention and the cited references were discussed in view of the proposed amendments to the claims (*see* Examiner's Interview Summary dated December 22, 2014).

Regarding the Examiner's position that the Flentov reference teaches detecting a first user-defined event based on (i) one of the user-defined operational parameters and (ii) the

STATEMENT OF SUBSTANCE OF INTERVIEW

Appln. No.: 90/013,201

Attorney Docket No.: A209779

movement data, PO's representative explained that the detection of the asserted event in Flentov is not based on the movement data.

Additional clarifying amendments were discussed to tie the claimed first time stamp information such that it reflects a time at which the movement data causing the first user-defined event occurred.

The Examiners agreed that if a formal response is filed with clarifying amendments along the lines discussed during the interview, the Examiners would reconsider their current position regarding the combination of references (i.e., Flentov/Vock with Burdea).

It is respectfully submitted that the instant STATEMENT OF SUBSTANCE OF INTERVIEW complies with the requirements of 37 C.F.R. §§1.2 and 1.133 and MPEP §713.04.

It is believed that no petition or fee is required. However, if the USPTO deems otherwise, Patent Owner hereby petitions for any extension of time which may be required to maintain the pendency of this case, and any required fee, except for the Issue Fee, for such extension is to be charged to Deposit Account No. 19-4880.

Respectfully submitted,

/Abdul-Quadeer Ahmed/

SUGHRUE MION, PLLC
Telephone: 202.293.7060
Facsimile: 202.293.7860

WASHINGTON OFFICE

23373

CUSTOMER NUMBER

Date: January 8, 2015

Quadeer A. Ahmed
Registration No. 60,835

Electronic Acknowledgement Receipt

EFS ID:	21156474
Application Number:	90013201
International Application Number:	
Confirmation Number:	9930
Title of Invention:	TRAINING AND SAFETY DEVICE, SYSTEM AND METHOD TO AID IN PROPER MOVEMENT DURING PHYSICAL ACTIVITY
First Named Inventor/Applicant Name:	6059576
Customer Number:	23373
Filer:	Quadeer A. Ahmed/Carolyn Tavernese
Filer Authorized By:	Quadeer A. Ahmed
Attorney Docket Number:	A209779
Receipt Date:	08-JAN-2015
Filing Date:	04-APR-2014
Time Stamp:	14:37:40
Application Type:	Reexam (Patent Owner)

Payment information:

Submitted with Payment	no
------------------------	----

File Listing:

Document Number	Document Description	File Name	File Size(Bytes)/ Message Digest	Multi Part /.zip	Pages (if appl.)
1	Applicant summary of interview with examiner	A209779StatementofSubstanceofInterview.pdf	21646 <small>2f4942697453ae0a3f51c5739ac562ff7578791f</small>	no	2

Warnings:

Information:

This Acknowledgement Receipt evidences receipt on the noted date by the USPTO of the indicated documents, characterized by the applicant, and including page counts, where applicable. It serves as evidence of receipt similar to a Post Card, as described in MPEP 503.

New Applications Under 35 U.S.C. 111

If a new application is being filed and the application includes the necessary components for a filing date (see 37 CFR 1.53(b)-(d) and MPEP 506), a Filing Receipt (37 CFR 1.54) will be issued in due course and the date shown on this Acknowledgement Receipt will establish the filing date of the application.

National Stage of an International Application under 35 U.S.C. 371

If a timely submission to enter the national stage of an international application is compliant with the conditions of 35 U.S.C. 371 and other applicable requirements a Form PCT/DO/EO/903 indicating acceptance of the application as a national stage submission under 35 U.S.C. 371 will be issued in addition to the Filing Receipt, in due course.

New International Application Filed with the USPTO as a Receiving Office

If a new international application is being filed and the international application includes the necessary components for an international filing date (see PCT Article 11 and MPEP 1810), a Notification of the International Application Number and of the International Filing Date (Form PCT/RO/105) will be issued in due course, subject to prescriptions concerning national security, and the date shown on this Acknowledgement Receipt will establish the international filing date of the application.



UNITED STATES PATENT AND TRADEMARK OFFICE

UNITED STATES DEPARTMENT OF COMMERCE
United States Patent and Trademark Office
Address: COMMISSIONER FOR PATENTS
P.O. Box 1450
Alexandria, Virginia 22313-1450
www.uspto.gov

APPLICATION NO.	FILING DATE	FIRST NAMED INVENTOR	ATTORNEY DOCKET NO.	CONFIRMATION NO.
90/013,201	04/04/2014	6059576	A209779	9930

23373 7590 12/22/2014
SUGHRUE MION, PLLC
2100 PENNSYLVANIA AVENUE, N.W.
SUITE 800
WASHINGTON, DC 20037

EXAMINER

DEMILLE, DANTON D

ART UNIT	PAPER NUMBER
3993	

MAIL DATE	DELIVERY MODE
12/22/2014	PAPER

Please find below and/or attached an Office communication concerning this application or proceeding.

The time period for reply, if any, is set in the attached communication.

Ex Parte Reexamination Interview Summary	Control No. 90/013,201	Patent Under Reexamination 6059576
	Examiner DANTON DE MILLE	Art Unit 3993

All participants (USPTO personnel, patent owner, patent owner's representative):

- | | |
|---------------------------|-----------------------------|
| (1) <u>Danton DeMille</u> | (4) <u>Quadeer Ahmed</u> |
| (2) <u>Eileen Lillis</u> | (5) <u>Carl Pelegrini</u> |
| (3) <u>Jimmy Foster</u> | (6) <u>William Mandir</u> |
| | (7) <u>Aiyda Ghahramani</u> |

Date of Interview: 18 December 2014

Type: a) Telephonic b) Video Conference
c) Personal (copy given to: 1) patent owner 2) patent owner's representative)

Exhibit shown or demonstration conducted: d) Yes e) No.
If Yes, brief description: _____

Agreement with respect to the claims f) was reached. g) was not reached. h) N/A.
Any other agreement(s) are set forth below under "Description of the general nature of what was agreed to..."

Claim(s) discussed: 1, 13 and 20.

Identification of prior art discussed: art of record.

Description of the general nature of what was agreed to if an agreement was reached, or any other comments:
See Continuation Sheet.

(A fuller description, if necessary, and a copy of the amendments which the examiner agreed would render the claims patentable, if available, must be attached. Also, where no copy of the amendments that would render the claims patentable is available, a summary thereof must be attached.)

A FORMAL WRITTEN RESPONSE TO THE LAST OFFICE ACTION MUST INCLUDE PATENT OWNER'S STATEMENT OF THE SUBSTANCE OF THE INTERVIEW. (See MPEP § 2281). IF A RESPONSE TO THE LAST OFFICE ACTION HAS ALREADY BEEN FILED, THEN PATENT OWNER IS GIVEN ONE MONTH FROM THIS INTERVIEW DATE TO PROVIDE THE MANDATORY STATEMENT OF THE SUBSTANCE OF THE INTERVIEW (37 CFR 1.560(b)). THE REQUIREMENT FOR PATENT OWNER'S STATEMENT CAN NOT BE WAIVED. EXTENSIONS OF TIME ARE GOVERNED BY 37 CFR 1.550(c).

/Danton DeMille/ Patent Reexamination Specialist Art Unit 3993	/JGF/	/EDL/
--	-------	-------

cc: Requester (if third party requester)

U.S. Patent and Trademark Office
PTOL-474 (Rev. 04-01)

Ex Parte Reexamination Interview Summary

Paper No. 20141218

Continuation of Description of the general nature of what was agreed to if an agreement was reached, or any other comments: Patent owner proposed an amendment, see attachment, based on the opinion that the examiner interpreted the claim language "detecting a first user-defined event based on at least one of the user-defined operational parameters and the movement data..." to mean "detecting a first user-defined event based on at least one of the user-defined operational parameters and/or the movement data". The user-defined event of the instant invention is based on the user-defined operational parameter and the movement data i.e., is a specific characteristic of the movement data.

The Office's interpretation of the claim language is that the detection was based on at least one user-defined operational parameter and the movement data. The user-defined event was the run down the mountain based on the user defined operational parameters which is when the user presses start button at the top of the run and presses the stop button at the end of the run. The movement data is what is being accumulated from the time the user pressed the start button until the user presses the stop button. Broadly, the user-defined event, as claimed, is based on a user-defined parameter such as pushing the start button at the beginning and pressing the stop button at the end to define the parameters of the movement data.

It was discussed that tying the time stamp to the movement (or to the sensing of the movement) of the user-defined event would mean that the time stamp is not interpreted to indicate the time of an entire activity within which the movement took place, but only that of the movement. Patent Owner asserted in the interview that the various art combinations applied in the Final rejection failed to suggest providing a time stamp to sensed movement in a user-defined event (which is based on user-defined operational parameters and the movement data).

Discussed changing the language to state "detecting a first user-defined event based on the movement data and at least one of the user-defined operational parameters". However, this still defines the event based on the parameters and the movement data. It was also discussed modifying "storing first event information related to the detected first user-defined event along with first time stamp information reflecting a time at which the first user-defined event occurred" to be "storing first event information related to the detected first user-defined event along with first time stamp information reflecting a time at which the movement data causing the first user defined event".

Formal amendment to follow.

FAX COVER SHEET

TO	(Manual Fax Entry)
COMPANY	Fax Recipient
FAX NUMBER	15712734974
FROM	SUGHRUE MION
DATE	2014-12-15 18:45:02 EST
RE	[12670] Agenda for the Personal Interview (Control No. 90/013,201; Attorney Docket No.: A209779)

COVER MESSAGE

Dear Examiner DeMille,
 Please find attached the agenda for the interview this Thursday.
 Best,
 Quadeer

Sughrue Mion, PLLC |, Office: | Fax:

Warning: In rare cases, our e-mail filtering software may eliminate legitimate email from clients unnoticed. Therefore, if your mail contains important instructions, please make sure that we acknowledge receipt of those instructions.
 This message is intended only for the designated recipient(s). It may contain confidential or proprietary information and may be subject to the attorney-client privilege or other confidentiality protections. If you are not a designated recipient, you may not review, copy or distribute this message. If you receive this in error, please notify the sender by reply e-mail to coordinate retrieval or deletion of this message. Thank you.

Control No.: 90/013,201
Atty. Docket No.: A209779

FORDISCUSSION ONLY, DO NOTENTER

Agenda for the Personal Interview

Date / time of Interview

December 18, 2014 at 10AM

Scheduled Participants

Applicant's representative(s):	William H. Mandir, Reg. No. 32,156 Carl J. Pellegrini, Reg. No. 40,766 Quadeer A. Ahmed, Reg. No. 60,835 Aiyda Ghahramani (202) 857-3207 (voice - Quadeer)
USPTO:	Examiner Danton DeMille Supervisor Eileen Lillis (571) 272-4974 (voice) (571) 273-4974 (fax)

It is Applicant's intention that such an interview will lead to an agreeable resolution of the rejected claims.

Claims 1, 13, 20, 21, 31-33, 35-56, 58, 60, 61, 64-66, 68-73, 75-77, 79-99, 101, 103, 104, 107-116, 118-120, 122-142, 144, 146, 147, and 150-204 are subject to reexamination.

During the interview, Patent Owner's representatives would appreciate the opportunity to discuss a proposed clarifying amendment to claim 1 in light of the Examiner's comments in the Office Action dated December 10, 2014.

The proposed amendment is shown in the attached Appendix.

In particular, the proposed amendment relates to the following portion of claim 1:
"detecting a first user-defined event based on at least one of the user-defined operational parameters and the movement data,..."

The Examiner appears to be interpreting this feature to mean that the detection of the event is based on (i) one of the user-defined operational parameters **and/or** (ii) the movement data.

The Examiner's interpretation appears to be based on the "at least one of" language in the claim.

However, the PO's intention is for the "at least one of" to qualify the plural user-defined operational parameters rather than qualifying the operational parameters and the movement data.

In other words, the PO's intention is for this claim to be interpreted to mean that the detection of the event is based on (i) one of the user-defined operational parameters **and**(ii) the movement data.

Accordingly, as shown in the attached Appendix, PO is proposing to amend claim 1 to recite:

Control No.: 90/013,201
Atty. Docket No.: A209779

FOR DISCUSSION ONLY, DO NOT ENTER

detecting a first user-defined event based on at least one of the user-defined operational parameters, and **based on** the movement data...

Similar amendments could be made to the other independent claims (namely, claims 13 and 20).

As such, in the claimed invention, the first user-defined event is detected based on two pieces of information - a user-defined operational parameter and the movement data.

On the other hand, as acknowledged in the Office Action, the alleged event in Flentov occurs when the user pushes a button 58 instructing the system to stop recording movement data (Office Action, paragraph bridging pages 7-8).

That is, the detection of the alleged event is solely based on the button 58 being pushed and *not based on any movement data*.

For example, regardless of how long or short the run is which would presumably correlate to the amount of movement data, the end of the event is detected based on the button 58 being pushed - the amount of movement data does not at all factor into the detection of the event.

Accordingly, based on the clarifying amendment discussed above, it is respectfully submitted that Flentov alone, or in combination with Burdea, does not and cannot teach all the features of claim 1.

In view of the foregoing, it is believed that the proposed arguments and amendments discussed above would overcome the relevant rejections of record and thus would confirm the patentability of the claims subject to this reexamination.

However, if the Examiners have any additional suggestions for further clarifying the claimed subject matter, Applicant's representatives would welcome such suggestions during the personal interview.

Control No.: 90/013,201
Atty. Docket No.: A209779

FORDISCUSSION ONLY, DO NOT ENTER

APPENDIX

PROPOSED AMENDMENT TO CLAIM 1

1. (currently amended): A portable, self-contained device for monitoring movement of body parts during physical activity, said device comprising:

a movement sensor capable of measuring data associated with unrestrained movement in any direction and generating signals indicative of said movement;

a power source;

a microprocessor connected to said movement sensor and to said power source, said microprocessor capable of receiving, interpreting, storing and responding to said movement data based on user-defined operational parameters, detecting a first user-defined event based on at least one of the user-defined operational parameters, and based on the movement data, and storing first event information related to the detected first user-defined event along with first time stamp information reflecting a time at which the first user-defined event occurred;

at least one user input connected to said microprocessor for controlling the operation of said device;

a real-time clock connected to said microprocessor;

memory for storing said movement data; and

an output indicator connected to said microprocessor for signaling the occurrence of user-defined events;

wherein said movement sensor measures the angle and velocity of said movement.



UNITED STATES PATENT AND TRADEMARK OFFICE

UNITED STATES DEPARTMENT OF COMMERCE
United States Patent and Trademark Office
Address: COMMISSIONER FOR PATENTS
P. O. Box 1450
Alexandria, Virginia 22313-1450
www.uspto.gov

Table with 5 columns: APPLICATION NO., FILING DATE, FIRST NAMED INVENTOR, ATTORNEY DOCKET NO., CONFIRMATION NO.
90/013,201 04/04/2014 6059576 A209779 9930

23373 7590 12/10/2014
SUGHRUE MION, PLLC
2100 PENNSYLVANIA AVENUE, N.W.
SUITE 800
WASHINGTON, DC 20037

Table with 1 column: EXAMINER

DEMILLE, DANTON D

Table with 2 columns: ART UNIT, PAPER NUMBER

3993

Table with 2 columns: MAIL DATE, DELIVERY MODE

12/10/2014

PAPER

Please find below and/or attached an Office communication concerning this application or proceeding.

The time period for reply, if any, is set in the attached communication.

Office Action in Ex Parte Reexamination	Control No. 90/013,201	Patent Under Reexamination 6059576	
	Examiner DANTON DE MILLE	Art Unit 3993	AIA (First Inventor to File) Status No

-- The MAILING DATE of this communication appears on the cover sheet with the correspondence address --

- a. Responsive to the communication(s) filed on 10/14/2014.
 A declaration(s)/affidavit(s) under 37 CFR 1.130(b) was/were filed on _____.
- b. This action is made FINAL.
- c. A statement under 37 CFR 1.530 has not been received from the patent owner.

A shortened statutory period for response to this action is set to expire 2 month(s) from the mailing date of this letter. Failure to respond within the period for response will result in termination of the proceeding and issuance of an *ex parte* reexamination certificate in accordance with this action. 37 CFR 1.550(d). **EXTENSIONS OF TIME ARE GOVERNED BY 37 CFR 1.550(c).** If the period for response specified above is less than thirty (30) days, a response within the statutory minimum of thirty (30) days will be considered timely.

Part I THE FOLLOWING ATTACHMENT(S) ARE PART OF THIS ACTION:

1. Notice of References Cited by Examiner, PTO-892. 3. Interview Summary, PTO-474.
2. Information Disclosure Statement, PTO/SB/08. 4. _____.

Part II SUMMARY OF ACTION

- 1a. Claims 1,13,20,21,31-33,35-56,58,60,61,64-66,68-73,75-77,79-99,101,103,104,107-116,118-120,122-142,144,146,147 and 150-204 are subject to reexamination.
- 1b. Claims 2-12,14-19 and 22-29 are not subject to reexamination.
2. Claims 30,34,57,59,62,63,67,74,78,100,102,105,106,117,121,143,145,148 and 149 have been canceled in the present reexamination proceeding.
3. Claims 162,164-167,170-173,177,179-182,185-188,193,195-198 and 201-204 are patentable and/or confirmed.
4. Claims 1,13,20,21,31-33,35-56,58,60,61,64-66,68-73,75-77,79-99,101,103,104,107-116,118-120,122-142,144,146,147,150-161,163,168,169,174-176,178,183,184,189-192,194,199 and 200 are rejected.
5. Claims _____ are objected to.
6. The drawings, filed on _____ are acceptable.
7. The proposed drawing correction, filed on _____ has been (7a) approved (7b) disapproved.
8. Acknowledgment is made of the priority claim under 35 U.S.C. § 119(a)-(d) or (f).
a) All b) Some* c) None of the certified copies have
1 been received.
2 not been received.
3 been filed in Application No. _____ .
4 been filed in reexamination Control No. _____ .
5 been received by the International Bureau in PCT application No. _____ .
* See the attached detailed Office action for a list of the certified copies not received.
9. Since the proceeding appears to be in condition for issuance of an *ex parte* reexamination certificate except for formal matters, prosecution as to the merits is closed in accordance with the practice under *Ex parte* Quayle, 1935 C.D. 11, 453 O.G. 213.
10. Other: _____

cc: Requester (if third party requester)

U.S. Patent and Trademark Office

PTOL-466 (Rev. 08-13)

Office Action in Ex Parte Reexamination

Part of Paper No. 20141021

Ex Parte Reexamination Office Action

Reexamination was requested and ordered for claims 1, 13, 20 and 21 of United States Patent Number 6,059,576 (hereinafter, “the ‘576 patent”). There were originally 29 claims in the patent. Patent owner also submitted new claims 30-158 at the time of filing. A non-final Office action was mailed out 13 August 2014. In response thereto, patent owner cancelled claims 30, 34, 57, 59, 62, 63, 67, 74, 78, 100, 102, 105, 106, 117, 121, 143, 145, 148, and 149 and added claims 159-204. Accordingly, claims 1, 13, 20, 21, 31-33, 35-56, 58, 60, 61, 64-66, 68-73, 75-77, 79-99, 101,103, 104, 107-116, 118-120, 122-142, 144, 146, 147, and 150-204 are all the claims pending in this proceeding. Claims 1, 13 and 20 are the independent claims.

Prior Art Relied Upon by the Requester

Flentov et al.	(U.S. Pat. No. 5,636,146) cited by requester
Gaudet et al.	(U.S. Pat. No. 6,018,705) cited by requester
Vock et al.	(U.S. Pat. No. 6,266,623) cited by requester
Burdea et al.	(U.S. Pat. No. 5,429,140) cited by examiner

Claim Rejections - 35 USC § 103

Claims 1, 13, 20, 21, 31-33, 35-56, 58, 60, 61, 64-66, 68-73, 75-77, 79-99, 101, 103, 104, 107-116, 118-120, 122-142, 144, 146, 147, 150-161, 163, 168, 169, 174-176, 178, 183, 184, 189-192, 194, 199, 200 are rejected under pre-AIA 35 U.S.C. 103(a) as being unpatentable over Flentov et al. in view of Burdea et al.

Regarding claims 1, 13, 20, 21, 130, 131, 189, Flentov teaches a portable, self-contained device 10 for monitoring movement of body parts 28 during physical activity, column 1, lines 6-10:

The invention relates generally to the measurement of the loft time and speed of a vehicle relative to the ground. Such measurements are particularly useful in sporting activities like skiing and mountain biking where users desire information relating to their speed and/or loft, or "air" time.

The device 10 comprising a movement sensor 18, 20, capable of measuring data associated with unrestrained movement in any direction and generating signals indicative of said movement. The device 10 is attached to the ski of the user which would generate signals indicative of the unrestrained movement as the user freely navigates over the downhill course. The device also includes a power source 22.

A microprocessor subsystem 12 is also capable of receiving, interpreting, storing and responding to said movement data based on user-defined operational parameters from user input 14. The device includes at least one user input 14 in the form of at least buttons 58, 60, 62, 66 and 67. Flentov teaches in column 2, lines 36-40, "a user interface for providing external inputs to the apparatus, including one or more of the following: a start/stop button for selectively starting and stopping the acquisition of data by the apparatus".

As noted above, the movement sensor 18, 20 send signals indicative of the unrestrained movement to the microprocessor subsystem 12. The microprocessor 12 interprets the signals from the sensor, column 6, lines 19-22:

The speed information and loft time information are processed by the microprocessor subsystem 12 to quantify actual speed, e.g., in miles per hour, and actual loft time, e.g., in seconds.

The microprocessor stores the information, column 6 in lines 22-25, “[t]he actual speed and loft time are thereafter stored in internal memory 13”.

The microprocessor responds to the movement data based on user-defined operational parameters from the user input 14. Figure 4 illustrates a graph 70 of a representative vibrational spectrum 72 that is stored into the microprocessor subsystem 12, column 10, lines 29-37:

The vibrational spectrum between t1 and t2 [FIG. 4] is comparatively smooth as compared to the spectrum outside this region because the user's sporting vehicle (e.g., the ski or mountain bike) is in the air and is not therefore subjected to the random vibrations of the road or ski slope. Accordingly, this relatively smooth spectrum between t1 and t2 can be readily discerned from the rest of the spectrum by the microprocessor subsystem 12 and evaluated for "air" time: specifically, "air" time is t2-t1.

The microprocessor subsystem 12 responds to the vibrational spectrum 72 of the movement data based on user-defined operational parameters such as loft or “air” time derived from the “relatively smooth spectrum” between t1 and t2. The information is then displayed on display 16.

Flentov teaches many different embodiments for the speed sensor and the loft sensor. In column 17 Flentov teaches a loft sensor that is accelerometer based. In column 17, lines 24-37:

FIG. 13 illustrates a speed sensor 200 constructed according to the invention and which includes a plurality of accelerometers 202a-202d. The accelerometers 202a-202d sense various accelerations in their respective axes (accelerometers sense acceleration along a predefined axis, translational or rotational), and each of the outputs from the accelerometers are input to the microprocessor subsystem 204, e.g., the subsystem 12 of FIG. 1, via communication lines 206a-206d. The orientation of the sensitive axis of each accelerometer 202a-202d is stored in the microprocessor subsystem 204 so that a particular acceleration in one axis is properly combined with acceleration values in other axes (as described in more detail below in connection with FIGS. 14 and 14a).

Additionally, Flentov teaches in lines 58-62 of column 17:

It should be clear to those skilled in the art that fewer, or greater, numbers of accelerometers are within the scope of the invention, so long as they collectively determine speed. In effect, the fewer number of accelerometers results in reduced accuracy; not reduced functionality. Rather, in an ideal situation, one accelerometer can be used to detect speed; which is the integral of the acceleration over time. Further, a double integration over the same period provides distance; and, therefore, the invention can also provide distance in at least one embodiment of the invention.

Flentov teaches that one accelerometer can be used to detect speed and distance.

Flentov also teaches in column 18, lines 17-20 of using six accelerometers:

Specifically, six accelerometers are connected with various sensitive orientations to collect pitch 207*a* yaw 207*b*, roll 207*c*, surge 207*d*, heave 207*e*, and sway 207*f* accelerations.

Flentov also teaches how to derive speed and direction in column 18, lines 52-61:

Also shown in FIG. 14A are translational integrators 209*a*-209*c* which convert the compensated accelerations from inputs 207*d*-207*f* to translational velocities by integration. Integrators 210*a*-210*c* likewise integrate inputs of pitch 207*a*, yaw 207*b*, and roll 207*c* to angular velocity while integrators 211*a*-211*c* provide a further integration to convert the angular velocities to angular position. The angular positional information and translational velocity information is combined and processed at the speed and direction resolution section 212 to derive speed and direction.

Therefore, the movement sensor 200 measures the speed, angle and velocity of the movement. Speed and direction are calculated using the signals from the plural accelerometers of the speed sensor 200. The direction is an angle of the movement of the device in at least two axes i.e., horizontal and vertical.

Therefore, Flentov teaches speed sensor 200 provides a movement sensor that measures the angular position and translational velocity.

Flentov teaches the microprocessor subsystem 12 includes a clock element in column 9, lines 28-34:

the microprocessor subsystem 12 of FIG. 1 preferably includes a [clock] element (readily known to those skilled in the art) for indicating processed time over a selectable period (the microprocessor subsystem 12 can in fact include a 24-hour clock element, much the way a digital wrist-watch includes 24-hour information).

While the 24-hour clock element of Flentov is not recited as "a real-time clock" however, it is a computer clock that keeps track of the current time in order to determine loft time for example. Therefore it would appear that the 24-hour clock element recited by Flentov is "a real-time clock" for purposes of storing time in human units. This is different from hardware clocks which are only signals that govern digital electronics.

The instant invention defines the "real-time clock" in column 5, lines 33-37:

The microprocessor 32 is connected to a clock 46 which is used as an internal clock for coordinating the functioning of the microprocessor 32. The clock 46 also serves as a real time clock to provide date and time information to the microprocessor 32.

There does not appear to be any special definition for the term "real-time clock" as long as the clock serves to provide date and time information reflecting a time at which the first user-defined event occurs to be stored with the first event information. Flentov teaches storing the information in memory, 6:14-25:

During motion of the ski or mountain bike, the speed sensor 18 sends velocity information (over communication line 11a) to the microprocessor subsystem 12; while the loft sensor 20 sends loft or "air" time information (over communication line 11b) to the microprocessor subsystem 12. The speed information and loft time information are processed by the microprocessor subsystem 12 to quantify actual speed, e.g., in miles per hour, and actual loft time, e.g., in seconds. The actual speed and loft time are thereafter stored in internal memory 13 until, at least, the speed and time data are accessed by a user of the system 10.

Flentov teaches the microprocessor processes velocity information from the speed sensor and the loft information from the loft sensor and converts the speed into miles per hour and the loft into seconds and stores the information in memory 13.

Burdea also teaches a method to monitor physical movement of a body part. The system employs an electronic device which tracks and monitors an individual's motion through the use of sensors capable of measuring parameters associated with the individual's movement. In column 6, lines 30-33,

Patient data can be stored in database 114 for statistical purposes. Database 114 can include a time stamp for providing a time history of updates of the patient information.

Burdea teaches the convention of storing performance data over time that includes a time stamp for providing a time history of updates. A clock would be required in order to associate a specific time and day with each piece of performance data, in order to evaluate the user's history of performance data over many days. It would have been obvious to one of ordinary skill in the art to modify the clock of Flentov to provide a time stamp as taught by Burdea in order to maintain a time history of patient information for statistical purposes.

Regarding the new claim language added in the last amendment, the Flentov device is for "detecting a first user-defined event [such as a first run down the mountain] based on at least one of the user-defined operation parameters and the movement data" that records the physical activity that occurs from the top of the run to the bottom of the run. Flentov teaches 7:38-44:

A user presses the start/stop button 58 at the start of activity--such as at the start of skiing down a slope or biking down a trail--and presses the button 58 at the completion of activity to cease the acquisition of data

The at least one user-defined operational parameter is a predetermined threshold when the user is at the top of the run. The user predetermines at least one thresholds is when the user-defined event ends at the end of the run. At the end of the run, the user pushes button 58 a second time to stop recording movement data. When the user stops recording movement data,

the microprocessor stores the movement data along with the time stamp as taught by Burdea. The time stamp accurately stores the time and date in which the user-defined event occurred at the end of the run. Therefore, the modified Flentov device is for "storing first event information related to the detected first user-defined event along with first time stamp information reflecting a time at which the first user-defined event occurred" as claimed.

Regarding claim 13, in addition to the limitations of claim 1, claim 13 also recites an input/output port, a computer capable of interpreting and reporting the movement data based on operational parameters, and a download device connected to the movement measuring device and the computer for transmitting the movement data and operational parameters between the movement measuring device and the computer for analysis, reporting and operation purposes. Flentov already teaches an output indicator 16.

Burdea shows in figure 1, network 22 is capable of transmitting the movement data and operational parameters between the movement measuring device or sensing glove 30 and the remote computer 20. The remote workstation 20 is used for receiving diagnostic information and communicating rehabilitation instructions to the movement measuring device. Burdea column 4, lines 46-50:

Remote workstation 20 can be coupled over network 22 to computer workstation 14. Remote workstation 20 can be used at a medical specialist location for receiving diagnostic information and communicating rehabilitation instructions to computer workstation 14.

Broadly, the network 22 includes the input/output port and the network card is the download device electronically connected to said movement measuring device 30 and a remote computer 20 for transmitting and receiving information. It would have been obvious to one of ordinary skill in the art to further modify Flentov to include an input/output port, computer and

download device as taught by Burdea so that a remote specialist can review historical data and suggest new instructions.

Regarding claim 20, Flentov teaches a method of monitoring physical movement of a body part comprising the steps of attaching a portable, self-contained movement measuring device 10 to the body part for measuring unrestrained movement in any direction. The movement measuring device 10 measures data associated with the physical movement. The microprocessor 13 within the movement measuring device 10 interprets the physical movement data based on user-defined operational parameters.

Burdea teaches using a “real-time clock” for adding a time stamp to the movement data so that the user movement data can be stored in memory for statistical purposes.

Regarding the new claim language added in the last amendment, the Flentov device includes a microprocessor 13 for “detecting a first user-defined event [such as a first run down the mountain] based on at least one of the user-defined operation parameters and the movement data” that records the physical activity that occurs from the top of the run to the bottom of the run. Flentov teaches 7:38-44:

A user presses the start/stop button 58 at the start of activity--such as at the start of skiing down a slope or biking down a trail--and presses the button 58 at the completion of activity to cease the acquisition of data

The at least one user-defined operational parameter is a predetermined threshold when the user at the top of the run predetermines when the user-defined event occurs at the end of the run. At the end of the run, the user pushes button 58 a second time to stop recording movement data. When the user stops recording movement data, the microprocessor stores the movement data along with the time/date stamp from the “real-time clock” as taught by Burdea. The time

stamp accurately stores the time/date in which the user-defined event occurred at the end of the run. Therefore, the modified Flentov device is for "storing first event information related to the detected first user-defined event along with first time stamp information reflecting a time at which the first user-defined event occurred" as claimed.

It would have been obvious to one of ordinary skill in the art to modify Flentov to include a "real-time clock" for adding a time stamp to the movement data as taught by Burdea to be stored in memory for storing data for statistical purposes thereby providing historical progress, see column 6, lines 30-33. Any conventional means to tag a date and time stamp to the movement data for providing statistical information over time would have been obvious to one of ordinary skill. A real-time clock is a well-known example of a means to provide a date and time stamp. It would have been obvious to one of ordinary skill in the art to modify Flentov to include a time/date stamp as taught by Burdea such as real-time clock in order to track the movement data over time thereby compare the previous movement data to the current movement data.

Regarding claim 21, as set forth above in rejection of claim 1, Flentov also teaches how to derive speed and direction in column 18, lines 52-61:

Also shown in FIG. 14A are translational integrators 209a-209c which convert the compensated accelerations from inputs 207d-207f to translational velocities by integration. Integrators 210a-210c likewise integrate inputs of pitch 207a, yaw 207b, and roll 207c to angular velocity while integrators 211a-211c provide a further integration to convert the angular velocities to angular position. The angular positional information and translational velocity information is combined and processed at the speed and direction resolution section 212 to derive speed and direction.

Flentov already teaches the movement sensor measures the velocity and direction.

Regarding claim 31, the microprocessor also stores in memory the date associated with the time stamp.

Regarding claim 32, the microprocessor 13 retrieves the time stamp, as taught by Burdea, with the date from the “real-time clock” to associate the time stamp with the first user-defined event.

Regarding claim 33, the microprocessor 13 retrieves the time stamp, as taught by Burdea, from the “real-time clock” based on the occurrence of the user defined event.

Regarding claim 35, Flentov teaches “[t]he memory may be nonvolatile such as battery backed RAM or Electrically Erasable Programmable Read Only Memory (EEPROM)” column 14, lines 33-35. Therefore, the memory continues to store movement data in response to battery power being lost from said power source.

Regarding claims 36, 37, Flentov teaches in column 2, lines 36-40, “a user interface for providing external inputs to the apparatus, including one or more of the following: a start/stop button for selectively starting and stopping the acquisition of data by the apparatus”. The movement sensor continuously checks for movement when the user presses the start button. It will continue to check for movement data until the user presses the start/stop button to stop the microprocessor from processing movement data.

Regarding claims 38-40, the output indicator 16 displays information signaling the occurrence of the first user-defined event based on the detection of the first user-defined event. The first user-defined event would be defined when the user presses the start/stop button 58 to stop processing movement data. The first user-defined event would be completed at that point. The movement data and the time stamp would be stored in memory. The output indicator would

then signal the occurrence of the first user-defined event. The first user-defined event can be indexed by the type of event and/or by the time stamp associated with the data. Such details are well within the realm of the artisan of ordinary skill in the art of data storage and retrieval when recording data and retrieving the data.

Regarding claims 41, 85 and 128, as noted above, Flentov teaches “detecting a first user-defined event [such as a first run down the mountain] based on at least one of the user-defined operation parameters and the movement data”. The device records the physical activity that occurs from the top of the run to the bottom of the run. The at least one user-defined operational parameter is a predetermined threshold when the user, at the top of the run, predetermines when at least one of the user-defined operational parameters at the end of the run. At the end of the run, the user pushes button 58 a second time to stop recording movement data. The first user-defined event occurs when the movement data reaches the predetermined threshold at the end of the run. When the movement data reaches the predetermined threshold, the microprocessor stores the movement data along with the time stamp as taught by Burdea. The time stamp accurately stores the time in which the user-defined event occurred at the end of the run. The Merriam-Webster Dictionary defines THRESHOLD as “END, BOUNDARY”. The predetermined threshold is the END or BOUNDARY of the movement data.

Regarding claim 42, the output indicator 16 is configured to display information signaling the occurrence of the first user-defined event [run down the mountain] when the movement data reaches the predetermined threshold. The output indicator or display 16 is configured to display speed and loft information for example.

Regarding claim 43, the memory 13 is configured to store the first event information indicating that the predetermined threshold is met.

Regarding claim 44, as taught by Burdea, as noted above, the microprocessor associates the time/date stamp with the movement data in association with the first event information.

Regarding claim 45, one of ordinary skill in the art having devices that include batteries would require some form of output indication to let the user know when the batteries are about to die. Such is well within the realm of the artisan of ordinary skill.

Regarding claim 46, Flentov teaches at the top of column 2, the display can be a LCD or LED display.

Regarding claim 47, Burdea shows in figure 1, network 22 is capable of transmitting the movement data and operational parameters between the movement measuring device or sensing glove 30 and the remote computer 20. The remote workstation is used for receiving diagnostic information and communicating rehabilitation instructions to the movement measuring device.

Burdea column 4, lines 46-50:

Remote workstation 20 can be coupled over network 22 to computer workstation 14. Remote workstation 20 can be used at a medical specialist location for receiving diagnostic information and communicating rehabilitation instructions to computer workstation 14.

Broadly, the network 22 includes the input/output port and the network card is the download device electronically connected to said movement measuring device 30 and a remote computer 20 for transmitting and receiving information. It would have been obvious to one of ordinary skill in the art to further modify Flentov to include an input/output port, computer and download device as taught by Burdea so that a remote specialist can review historical data and suggest new instructions.

Regarding claims 48, 49, as noted above, Burdea teaches remote workstation 20 can be coupled over network 22 to computer workstation 14. Obviously, computer workstation 14 has software configured to communicate with external software in the remote workstation 20 wherein the external software is configured to present the downloaded movement data to the user in the display. It would have been obvious to one of ordinary skill in the art to further modify Flentov to be able to download the physical activity from the local microprocessor to an external computer over a network as taught by Burdea in order to have the information saved at a different location so the information can be analyzed by a specialist and processed for improving the user's performance.

Regarding claim 50, Burdea teaches the downloaded movement data is analyzed by a specialist and therefore is capable of being analyzed by the user via said external software.

Regarding claims 51-54, 136-140, the external software is configured to interpret the movement data and produce at least one report. Burdea teaches producing a hard copy of diagnostic information including progress charts 4:43-50. The purpose of the external computer is to analyze the data and to communicate new instructions for the user. Producing history reports on the time-stamped, movement data would be obvious to one of ordinary skill in the art in order to produce historical data for developing new instructions for the user. Such would have been an obvious provision in Flentov.

Regarding claims 55, 141, the movement data is configured to be downloaded to the computer via a wired connection. Burdea's network 22 is a wired connection.

Regarding claims 56, 142, wireless connections are old and well known and an obvious equivalent means of communicating information from one computer to another.

Regarding claim 58, the output indicator 52 is configured to provide a visual indicator to the user regarding the threshold being met. The output indicator 52 would display the results.

Regarding claims 60, 61, 130, 146, 147, the memory stores the user-defined operational parameters comprising a plurality of thresholds respectively corresponding to a plurality of notifications. One type of operational parameters occurs each time the loft or “air” time event happens. It includes the smooth vibrational spectrum threshold between t1 and t2 as shown in figure 4. Each time the movement data reaches this threshold, the microprocessor is configured to detect that the loft or “air” time user-defined event has occurred. The microprocessor is configured to calculate the actual loft or “air” and will send the information to the output indicator to display the loft or “air” time data indicating that the user-defined loft or “air” time event has occurred.

Regarding claim 64, the plurality of loft or “air” time thresholds are different from each other because they occur at different times and the loft or “air” time data itself will also be different.

Regarding claim 65, the plurality of notifications have different visual indicators because the notification will have to distinguish the first loft or “air” time event from the second loft or “air” time event and so on.

Regarding claim 66, the prior art has already established the user of using visual indicators and including a blinking indicator is old and well known and an obvious provision in the art of displaying information on a display screen. Blinking indicators is well known to draw the user’s attention to the information displayed because it has a particular importance above other information that is being displayed. Where the general conditions of a claim are disclosed

in the prior art, it is not inventive to discover the optimum or workable ranges by routine experimentation. *In re Swain et al.*, 33 CCPA (Patents) 1250, 156 F.2d 239, 70 USPQ 412; *Minnesota Mining and Mfg. Co. v. Coe*, 69 App. D.C. 217, 99 F.2d 986, 38 USPQ 213; *Allen et al. v. Coe*, 77 App. D.C. 324, 135 F.2d 11, 57 USPQ 136. Providing blinking lights to highlight a portion of the display is well within the realm of the artisan of ordinary skill in the art at the time of the invention for displaying information on a display screen.

Regarding claims 68, 128, 154, the microprocessor is configured to detect occurrence of the first user-defined even by comparing the movement data to the predetermined threshold which is when the user stops the collection of movement data.

Regarding claims 69, 155, Flentov teaches in column 19, lines 12-16:

It should be apparent to those in the art that the accelerometers of FIG. 13-14 provide sufficiently detailed information such that the whole of the system according to the invention can be mounted to a user of the system directly, rather than directly to a vehicle.

The sensor can be mounted on the user of the system directly.

Regarding claims 70, 155, the sensor can be mounted on the arm of the user and therefore measures movement of the user's arm.

Regarding claims 71, 72, as noted above, Flentov measures distance as well as speed. Flentov teaches in column 17, lines 63-66, "one accelerometer can be used to detect speed; which is the integral of the acceleration over time. Further, a double integration over the same period provides distance". Therefore, the movement sensor of Flentov would also measure distance regardless if user is walking, skiing or biking.

Regarding claims 73, 116, 158, as noted above, Burdea teaches including a time stamp for storing the time/date stamp with the movement data for providing a time history of updates of

the user performance. The microprocessor stores in memory the movement data associated with the time stamp.

The movement sensor continuously checks for movement as long as the device is turned on. Flentov teaches 6:14-25:

During motion of the ski or mountain bike, the speed sensor 18 sends velocity information (over communication line 11a) to the microprocessor subsystem 12; while the loft sensor 20 sends loft or "air" time information (over communication line 11b) to the microprocessor subsystem 12. The speed information and loft time information are processed by the microprocessor subsystem 12 to quantify actual speed, e.g., in miles per hour, and actual loft time, e.g., in seconds. The actual speed and loft time are thereafter stored in internal memory 13 until, at least, the speed and time data are accessed by a user of the system 10.

The output indicator displays information indicating the occurrence of the first user-defined event based on the detection of the first user-defined event and the first time stamp information. The first user-defined event is based on all of the movement data that was processed during the run down the mountain and stored in memory. The output indicator would display information signaling the occurrence of the first user-defined event based movement data such as loft or "air" time and speed.

The physical movement data is stored along with the time stamp where the microprocessor interprets the physical movement data.

Burdea teaches the physical movement data is configured to be downloaded to a computer 14, 20.

Burdea teaches communicating with external software configured to run on the computer 14, 20 and present the interpreted physical movement data to the user.

The purpose of the computers is to analyze the data to produce reports based on the movement data in order to be presented to the user to improve their physical movement.

The memory stores the user-defined operational parameters such as loft or “air” time. The user-defined operational parameters comprise a plurality of thresholds respectively corresponding to a plurality of notifications such as loft or “air” time or speed. Each time the movement data reaches one of the plurality of thresholds, the microprocessor is configured to detect that one of the user-defined events occurred.

The sensor can be mounted on the user (Flentov 19:12-16). The arm of the user is part of the user and therefore measures movement of the user’s arm.

Regarding claim 75, as noted above, Burdea teaches storing a time stamp for associating the time/date stamp with the movement data for providing a time history of updates of the user performance.

Regarding claim 76, the microprocessor retrieves the time stamp from the real-time clock and associate the retrieved first time stamp with the received movement data as taught by Burdea.

Regarding claim 77, the microprocessor is configured to retrieve the time stamp from the real-time clock based on the occurrence of at least one of the user-defined events.

Regarding claims 79, 122, memory is configured to continuously store movement data in response to battery power being lost from the power source because the memory is nonvolatile such as battery backed RAM or Electrically Erasable Programmable Read Only Memory (EEPROM)”, Flentov column 14, lines 33-35.

Regarding claims 80, 81, 123, 124, the movement sensor continuously checks for movement and the microprocessor continuously interprets the movement data received from the movement sensor as long as the user presses the start button and the device is on 6:14-25.

Regarding claims 82, 83 and 84, the output indicator displays information signally the occurrence of the first user-defined event based on the detection of the first user-defined event and/or the first time stamp. Once the threshold has been met, the first user-defined event has been detected. The movement data is stored along with the time stamp. The output indicator will then display information indicating the first user-defined event such as speed and loft or “air” time.

Regarding claims 85 and 86, at least one of the user-defined operational parameters is a predetermined threshold such as when the user presses the button to stop processing the movement data. The user-defined event occurs when the movement data reaches the predetermined threshold. The output indicator is configured to display information signaling the occurrence of the first user-defined event e.g., loft time, when the movement data reaches the predetermined threshold, 8:20-21.

Regarding claim 87, memory is configured to store the information indicating that the threshold is met when the user stops processing movement data.

Regarding claim 88, memory stores the information indicating that the threshold is met including a time stamp in association with the first event information.

Regarding claims 89, 132, one of ordinary skill in the art having devices that include batteries would require some form of output to let the user know when the batteries are about to die.

Regarding claim 90, Flentov teaches at the top of column 2, the display can be a LCD or LED display.

Regarding claim 91, Burdea teaches the movement data stored in the memory is configured to be downloaded to the remote workstation 20.

Regarding claims 92, 93, as noted above, Burdea teaches remote workstation 20 can be coupled over network 22 to computer workstation 14. Obviously, computer workstation 14 has software configured to communicate with external software in the remote workstation 20 wherein the external software is configured to present the downloaded movement data to the user to be analyzed.

Regarding claim 94, the purpose of the external computer is for a specialist to analyze the data and to communicate new instructions for the user to the local workstation 14. Producing reports on the movement data including historical data would be obvious to one of ordinary skill in the art in order to properly analyze the data to develop new instructions for the user. Burdea teaches, column 4, lines 43-50, the workstation 14 is coupled to hard copy device 18 for producing a hard copy of diagnostic information including rehabilitation progress charts. Such can also be applied to the external computer 20.

Regarding claim 95, the external software is configured to interpret the movement data and produce at least one history report. The purpose of the external computer is to analyze the historical data. Producing reports on the movement data including historical data would be obvious to one of ordinary skill in the art in order to develop new instructions for the user.

Regarding claim 96, the history report obviously includes dates and time of the movement data. This is how one can analyze the progress of the user.

Regarding claim 97, the external software is configured to allow the user to program additional reports and histories as needed with respect to the movement data.

Regarding claim 98, the movement data is configured to be downloaded to the computer via a wired connection. Network 22 is a wired connection.

Regarding claim 99, wireless connections are old and well known and an obvious equivalent means of communicating information wirelessly.

Regarding claim 101, the output indicator 16 provides a visual indicator to the user regarding the threshold being met such as speed and “air” time.

Regarding claim 103, memory is configured to store the user-defined operational parameters and a plurality of thresholds respectively corresponding to a plurality of notifications. Each time the movement data reaches one of the thresholds such as loft or “air” time, the microprocessor is configured to detect that one of a plurality of user-defined events occurred.

Regarding claim 104, the microprocessor detects that one of the user-defined events occurred based on the movement data reaching one of the plurality of thresholds, the output indicator displays a corresponding one of the notifications indicating that one of the user-defined events has occurred such as loft or “air” time. The threshold is the smooth vibrational spectrum as shown in figure 4.

Regarding claims 107, 150, the plurality of thresholds are different from each other because each loft or “air” time would be different in duration.

Regarding claims 108, 151, 152, the plurality of notifications are different visual indicators because the speed measures miles per hour, “air” time measures in seconds. Additionally display 64 will display “S” to indicate speed information.

Regarding claims 109, 152, the prior art has already established the use of visual indicators to communicate different kinds of movement information to the user. A blinking

indicator is old and well known and an obvious provision in the art in order to highlight a particular piece of information on a display screen. Where the general conditions of a claim are disclosed in the prior art, it is not inventive to discover the optimum or workable ranges by routine experimentation. *In re Swain et al.*, 33 CCPA (Patents) 1250, 156 F.2d 239, 70 USPQ 412; *Minnesota Mining and Mfg. Co. v. Coe*, 69 App. D.C. 217, 99 F.2d 986, 38 USPQ 213; *Allen et al. v. Coe*, 77 App. D.C. 324, 135 F.2d 11, 57 USPQ 136. Providing blinking lights to highlight a portion of the display is well within the realm of the artisan of ordinary skill in the art of displaying information on a display screen.

Regarding claim 110, the output indicator is configured to signal the occurrence of user-defined events such as loft or “air” time.

Regarding claim 111, the microprocessor is configured to detect occurrence of the first user-defined even by comparing the movement data to the predetermined threshold which is when the user pressed the start/stop button to stop the collection of movement data.

Regarding claims 112, 113, 155, Flentov teaches in column 19, lines 12-16:

It should be apparent to those in the art that the accelerometers of FIG. 13-14 provide sufficiently detailed information such that the whole of the system according to the invention can be mounted to a user of the system directly, rather than directly to a vehicle.

The sensor can be mounted on the user of the system directly e.g., the arm of the user. Flentov teaches that the whole of the system can be mounted to a user of the system directly, rather than directly to a vehicle. When attached to the arm of the user it will measure movement of the arm as well as the whole of the body. The system will still measure movement of the body and the ski as a whole.

Regarding claim 114, the system of Flentov measures distance as noted above regardless of whether the user is skiing, biking, running or walking.

Regarding claim 115, as noted above, the whole of the system 10 can be mounted to the user and therefore is wearable and measures distances including walking, running, skiing or biking.

Regarding claims 118-120, as set forth above, Burdea teaches storing the time/date stamp to the first time stamp information.

Burdea also teaches retrieving the first time stamp information from the real-time clock and associate the retrieved first time stamp information with the first user-defined event.

Likewise, Burdea teaches retrieving the first time stamp information from the real-time clock based on the detection of the first user-defined event.

Regarding claim 122, Flentov teaches that memory can be EEPROM.

Regarding claim 123, the movement sensor continuously checks for movement once the user presses the start button, Flentov 7:38-42.

Regarding claim 124, Flentov teaches 6:14-22:

During motion of the ski or mountain bike, the speed sensor 18 sends velocity information (over communication line 11a) to the microprocessor subsystem 12; while the loft sensor 20 sends loft or "air" time information (over communication line 11b) to the microprocessor subsystem 12. The speed information and loft time information are processed by the microprocessor subsystem 12 to quantify actual speed, e.g., in miles per hour, and actual loft time, e.g., in seconds.

Regarding claims 125-127, displaying information signaling the occurrence of the first user-defined event based on the detection of the user-defined event and/or by the first time stamp information. The first user-defined event is the run down the mountain. In response to detecting the first user-defined event has occurred, the output indicator would display information

signaling the occurrence of the first user-defined event which would be loft or “air” time or speed.

Regarding claim 128, one of the user-defined operational parameters is a predetermined threshold such as loft or “air” time or speed. The first user-defined event occurs when the movement data reaches the predetermined threshold at the end of the run.

Regarding claim 129, the output indicator displays loft or “air” time information signaling the occurrence of the first user-defined event when the movement data reaches the predetermined threshold at the end of the run.

Regarding claims 130, 131, the device stores in memory said first event information and the time stamp information, as taught by Burdea, indicating that the predetermined threshold is met.

Regarding claims 133, 134, 135, Vock teaches in 8:11-15:

The speed information and loft time information are processed by the microprocessor subsystem 12 to quantify actual speed, e.g., in miles per hour, and actual loft time, e.g., in seconds. The actual speed and loft time are thereafter stored in internal memory 13

The physical movement data stored in memory is the interpreted physical movement data such as speed and loft time, and the stored physical movement data is configured to be downloaded to a computer as taught by Burdea. The external software is configured to run on the computer.

Regarding claims 137-140, Burdea teaches producing at least one report based on the interpreted physical movement data using the external software, Burdea 4:43-45. Additional reports would have been an obvious provision in order to maximize the ability of the specialist to develop the best set of instructions for the user.

Regarding claims 144, 153, Flentov teaches in column 8, lines 32-33, when the microprocessor determines when a threshold has been met, the display will signal the occurrence that the user-defined threshold has been met by displaying the loft time, for example.

Regarding claim 146, Flentov teaches in figure 4 a graph 70 of a representative vibrational spectrum 72 that is stored into the microprocessor subsystem 12. In column 10, lines 29-37:

The vibrational spectrum between t1 and t2 [in figure 4] is comparatively smooth as compared to the spectrum outside this region because the user's sporting vehicle (e.g., the ski or mountain bike) is in the air and is not therefore subjected to the random vibrations of the road or ski slope. Accordingly, this relatively smooth spectrum between t1 and t2 can be readily discerned from the rest of the spectrum by the microprocessor subsystem 12 and evaluated for "air" time: specifically, "air" time is t2-t1.

The user-defined operational parameters comprising a plurality of thresholds respectively corresponding to a plurality of notifications for determining the loft "air" time includes a relatively smooth vibrational spectrum between t1 and t2 readily discerned from the rest of the vibration spectrum. Detecting comprises detecting occurrence of one of a plurality of user-defined events each time the movement data reaches one of the plurality of these thresholds.

Regarding claim 147, the method further comprises displaying, via an output indicator a corresponding one of the notifications indicating that one of the user-defined events has occurred. The output indicator would display the loft or "air" time.

Regarding claim 150, the plurality of thresholds are different from each other. The many different loft or "air" times would indicate different loft or "air" time. Each user-defined event or "air" time would be different for each jump.

Regarding claim 151, the plurality of notifications are different visual indicators.

Flentov 8:30-35 states:

A display portion 68 of the display 52 shows a number corresponding to the sequential information on display. For example, the illustrated "1" number means that the highest "air" time record is currently being displayed; while a number greater than one means that a loft time other than the highest loft time is being displayed.

Each loft or "air" time would be ranked based on the highest "air" time record receiving the number "1". The next highest "air" time would be ranked number "2" and so on.

Regarding claim 152, the prior art has already established the convention of using visual indicators to display different results. Using a blinking indicator is old and well known and an obvious provision in the art of displaying information on a display screen in order to highlight one particular piece of data. Where the general conditions of a claim are disclosed in the prior art, it is not inventive to discover the optimum or workable ranges by routine experimentation. *In re Swain et al.*, 33 CCPA (Patents) 1250, 156 F.2d 239, 70 USPQ 412; *Minnesota Mining and Mfg. Co. v. Coe*, 69 App. D.C. 217, 99 F.2d 986, 38 USPQ 213; *Allen et al. v. Coe*, 77 App. D.C. 324, 135 F.2d 11, 57 USPQ 136. Providing blinking lights to highlight a portion of the display is well within the realm of the artisan of ordinary skill in the art of displaying information on a display screen.

Regarding claim 153, as noted above, the output indicator or display would signal the occurrence of the user-defined events such as loft or "air" time or speed.

Regarding claim 154, detecting comprises comparing said physical movement data to the predetermined threshold. As noted above, the smooth spectrum is the threshold for determining the loft or "air" time.

Regarding claim 156, measuring the data comprises measuring the data using an accelerometer of the portable, self-contained movement measuring device.

Regarding claims 159, 174 and 190, one of the user-defined operational parameters comprise a first predetermined threshold which is when the user has set the predetermined threshold for the loft or “air” time. A second predetermined threshold different from the first predetermined threshold is the speed.

The microprocessor is configured to interpret said movement data to determine whether the movement data reaches the first predetermined threshold which is the smooth portion 72 of the vibrational spectrum shown in figure 4 and whether the movement data reaches the second predetermined threshold when it determines whether a third condition is met. Flentov teaches 2:15-20:

One preferred aspect of the invention includes a speed sensor, connected to the microprocessor subsystem, which senses a third condition that is indicative of a velocity of the vehicle. In this aspect, the microprocessor subsystem includes means for converting the third condition to information representative of a speed of the vehicle.

Flentov teaches speed parameters in “a third condition that is indicative of a velocity of the vehicle.” “[T]he microprocessor subsystem includes means for converting the third condition to information representative of a speed of the vehicle.”

Regarding claim 160, the output indicator is configured to display first information indicating the occurrence of the first user-defined event when it is determined that the first predetermined threshold is met.

The output indicator is also configured to display second information indicating occurrence of the second user-defined event when it is determined that the second predetermined threshold is met such as speed of the user.

Regarding claim 161, the displayed first information, i.e., loft or “air” time, is different from the displayed second information i.e., speed.

Regarding claim 163, the first user-defined event is a predetermined type of movement such as the run down the mountain.

Regarding claims 168, 169, 183, 184, 199, 200, the microprocessor of Flentov is configured to detect a second event or run down the mountain, based on at least one of the user-defined operational parameters where the user stops collection and the movement data at the end of the run. The microprocessor is configured to store, in said memory, second event information related to the detected second event along with second time stamp information reflecting a time at which the second event occurred.

Regarding claims 175, 191, the output indicator is configured to display first information such as loft, indicating occurrence of the first user-defined event when it is determined that the first predetermined threshold is met and configured to display second information, such as speed, indicating occurrence of the second user-defined event when it is determined that the second predetermined threshold or “a third condition” is met. Flentov teaches 2:15-22:

One preferred aspect of the invention includes a speed sensor, connected to the microprocessor subsystem, which senses a third condition that is indicative of a velocity of the vehicle. In this aspect, the microprocessor subsystem includes means for converting the third condition to information representative of a speed of the vehicle.

Flentov teaches a third condition or threshold for speed that the microprocessor converts to information representative of speed.

Regarding claims 176, 192, the displayed first information is in seconds and the displayed second information is in miles per hour.

Regarding claims 178, 194, the first user-defined event is a predetermined type of movement skiing down a mountain.

Claims 20 and 118-120, 122-142, 144, 153, 154, 157, 194, 199, 200 are rejected under pre-AIA 35 U.S.C. 103(a) as being unpatentable over Gaudet et al. in view of Burdea et al.

Regarding claims 20, 118-120, Gaudet teaches a method of monitoring physical movement of body parts comprising attaching a portable, self-contained movement measuring device 20 to the body of the user for measuring unrestrained movement in any direction. The user is capable of moving unrestrained in any direction.

The method includes measuring data associated with the physical movement using the portable, self-contained movement measuring device 20.

The method includes interpreting, using a microprocessor 40 included in the portable, self-contained movement measuring device 20. Gaudet teaches 5:32-37:

FIG. 4 shows an exemplary embodiment of the foot contact time/foot loft time generator 20 shown in FIG. 3. As shown, foot contact time/foot loft time generator 20 includes an accelerometer 34, an amplifier circuit 38 (which has a high-pass filter 36 included within it), and a micro-controller 40.

The physical movement data is based on user-defined operational parameters. Gaudet teaches user-defined operational parameters in 16:60-64:

Alternatively, the parameters or variables could be adjusted automatically via software, based upon information input by the user (such as the pushing of a button both when the user starts and when the user finishes traversing a known distance).

Gaudet also teaches using timers, column 5, lines 12-14 (emphasis added):

According to one embodiment, foot contact time/foot loft time generator 20 includes a micro-controller [40] having virtually all circuitry, e.g., memory, **timers** and analog-to-digital (A/D) converters, on board, so that memory unit 54 need only be used to perform functions such as **permanently** storing data produced by foot contact time/foot loft time generator 20.

The timers are used to measure "air time" (Ta) and "contact time" (Tc). The method includes storing data in said memory 54.

Gaudet teaches 9:8-15:

The occurrence of a negative spike event causes an "air time" (Ta) timer in micro-controller 40 to stop and a "contact time" (Tc) timer to start. The time measured by the air time (Ta) timer represents the time difference between the last "positive spike event" (defined below) and the negative spike event just detected. When a negative spike event occurs, a "StepCount" value, i.e., a counted number of footsteps of the user, also is increment.

Likewise Gaudet teaches 9:46-51:

The occurrence of a positive spike event causes the contact time (Tc) timer to stop and causes the air time (Ta) timer to start. The time measured by the contact time (Tc) timer represents the time difference between the last negative spike event and the positive spike event just detected.

By measuring time intervals between these positive and negative spikes, average "foot contact times" (Tc) and "foot loft times" (Ta) of the user may be calculated. To derive the pace of the user, the average foot contact time is multiplied by a first constant if it is less than 400 milli-seconds (ms) and is multiplied by a second constant if it is greater than 400 ms. This pace value may, in turn, be used to calculate the distance traveled by the user.

The only difference between Gaudet and the claimed invention is using the timer of Gaudet to provide time stamp information to be added to the recorded movement data in order to keep track of the user's performance over time.

Burdea teaches a method to monitor physical movement of a body part. The system employs an electronic device which tracks and monitors an individual's motion through the use of sensors capable of measuring parameters associated with the individual's movement. In column 6, lines 30-33,

Patient data can be stored in database 114 for statistical purposes. Database 114 can include a time stamp for providing a time history of updates of the patient information.

Burdea teaches the convention of storing performance data over time including a time stamp with the data for providing a time history of updates. Gaudet already teaches a timer. A clock such as a real-time clock would be required in order to associate a specific time and day with each piece of performance data in order to evaluate the user's performance over many days. Any conventional means to tag a date and time stamp to the performance data for providing statistical information over time would have been obvious to one of ordinary skill. It would have been obvious to one of ordinary skill in the art to modify the timer of Gaudet to provide a time/date stamp as taught by Burdea to be associated with the movement data in order to maintain a time history of user information for statistical purposes.

Regarding claim 118, as noted above, Burdea teaches the convention of storing, in the memory, date information associated with the first time stamp information.

Regarding claims 119, 120, as noted above, the microprocessor a real-time clock is a conventional means to provide time and date information for storing with the movement data based on the detection of the first user-defined event.

Regarding claims 123, 124, Gaudet teaches in column 8, lines 54-59:

Essentially, continuous-loop portion 101 continuously monitors the voltage across inputs 46 and 48 of micro-controller 40 to determine when negative and positive voltages differences (between inputs 46 and 48) in excess of predetermined thresholds occur. These negative and positive voltage differences are indicative, respectively, of the foot of a user impacting with and leaving the ground.

In figure 5 of Gaudet, the output of accelerometer 32 is fed into the amplifier circuit 38 whose output is input to the microcontroller 40. Therefore the microcontroller has a continuous-loop algorithm 101 that continuously monitors the voltage across amplified signals from the accelerometer.

Regarding claim 125, Gaudet teaches displaying, using an output indicator 26A of the portable, self-contained movement measuring device, information signaling the occurrence of the first user-defined event based on the detection of the user-defined event. Gaudet teaches the user has defined the operational parameters of the event 16:60-64:

Alternatively, the parameters or variables could be adjusted automatically via software, based upon information input by the user (such as the pushing of a button both when the user starts and when the user finishes traversing a known distance).

The parameters are based upon information input by the user when the user starts and when the user finishes traversing a known distance.

Regarding claim 126, because the user has defined the first user-defined event, the microprocessor simultaneously retrieves the time and date information from the clock to associate it with the movement information and display the results.

Regarding claim 127, as noted above, the first user-defined event is based on the parameters set by the user and the time and date are automatically associated with the movement information. Therefore the display signaling the occurrence of the first user-defined event is based on both the detection of the user-defined event and the first time stamp information.

Regarding claim 128, the user-defined event is based on the parameters input by the user when the user starts and when the user finishes traversing a known distance. The user-defined event occurs when the movement data reaches the predetermined threshold.

Regarding claim 129, the display will signal the occurrence of the first-user defined event when the movement data reaches the predetermined threshold by displaying the results.

Regarding claim 130, as noted above, the microprocessor will store the first even information that indicates the predetermined threshold is met.

Regarding claim 131, as noted above, the microprocessor will store the first time stamp information in association with the first even information.

Regarding claim 132, in the art of portable battery operated devices, it is well-known to an artisan of ordinary skill to provide some indication that the battery power is getting low.

Regarding claim 133, “memory 54 need only be used to perform functions such as permanently storing data produced by foot contact time/foot loft time generator 20” Gaudet, 5:15-18.

Regarding claims 134, 135, as noted above, Burdea teaches remote workstation 20 can be coupled over network 22 to computer workstation 14. Obviously, computer workstation 14 has software configured to communicate with external software in the remote workstation 20 wherein the external software is configured to present the downloaded movement data to the user

in the display. Remote workstation 20 is for receiving performance data, analyze data and communicate new rehabilitation instructions to computer workstation 14.

Regarding claims 136-140, the external software is configured to interpret the movement data and produce at least one report. The purpose of the external computer is to analyze the data and to communicate new instructions for the user to the local workstation 14. Producing reports on the movement data including historical data would be obvious to one of ordinary skill in the art in order to develop new instructions for the user. Burdea teaches, column 4, lines 43-50, the workstation 14 is coupled to hard copy device 18 for producing a hard copy of diagnostic information including rehabilitation progress charts.

Regarding claim 141, the movement data is configured to be downloaded to the computer via a wired connection. Burdea's network 22 is a wired connection.

Regarding claim 142, wireless connections are old and well known and an obvious equivalent means of communicating information from one computer to another.

Regarding claim 144, the user-defined event is based on the parameters input by the user when the user starts and when the user finishes traversing a known distance, Gaudet;16:60-64. The user-defined event occurs when the movement data reaches the predetermined threshold set forth by the user. The output indicator will indicate the predetermined threshold being reached by displaying the results.

Regarding claims 153, 154, Gaudet teaches displaying, using an output indicator 26A of the portable, self-contained movement measuring device, information signaling the occurrence of the first user-defined event based on the detection of the user-defined event. Gaudet teaches the user has defined the operational parameters of the event 16:60-64:

Alternatively, the parameters or variables could be adjusted automatically via software, based upon information input by the user (such as the pushing of a button both when the user starts and when the user finishes traversing a known distance).

The parameters are based upon information input by the user when the user starts and when the user finishes traversing a known distance.

Regarding claim 157, as noted above, distance is one of the parameters that is measured and displayed.

Regarding claim 194, the first user-defined event is a predetermined type of movement i.e., walking.

Regarding claims 199 and 200, the microprocessor detects a second event based on at least one of the user-defined operational parameters and the movement data and storing in memory the second event information related to the detected second event along with second time stamp information reflecting a time at which the second event occurred. The second event would be when the user uses the portable, self-contained device a second time to record the walking activities.

Claim 122 is rejected under pre-AIA 35 U.S.C. 103(a) as being unpatentable over Gaudet and Burdea as applied to claim 20 above, and further in view of Flentov.

Regarding claim 122, Flentov teaches “[t]he memory may be nonvolatile such as battery backed RAM or Electrically Erasable Programmable Read Only Memory (EEPROM)” column 14, lines 33-35. Therefore, the memory continues to store movement data in response to battery power being lost from said power source. It would have been obvious to one of ordinary skill in

the art to further modify Gaudet to use EEPROM memory as taught by Flentov to store the information so that the information stored is not lost in the event of a power loss.

Claims 1, 13, 20 and 21, 31-33, 35-56, 58, 60, 61, 64-66, 68-73, 75-77, 79-99, 101, 103, 104, 107-116, 118-120, 122-142, 144, 146, 147, 150-161, 163, 168, 169, 174-176, 178, 183, 184, 189-192, 194, 199, 200 are rejected under pre-AIA 35 U.S.C. 103(a) as being unpatentable over Vock et al. in view of Burdea et al.

Regarding claims 1, 13, 20, 21, 31-33, 189, Vock teaches a portable, self-contained device 10 comprising a movement sensor 18, 20, a power source 22, a microprocessor 12, a user input 14, memory 13 and an output indicator 16 or display.

The movement sensor 18, 20 measures data associated with unrestrained movement in any direction and generating signals indicative of said movement. As shown in figure 2 the portable, self-contained device 10 is mounted to the ski of the user. The user can manipulate the skis in an unrestrained movement in any direction. The sensor 18, 20 generates signals indicative of the unrestrained movement.

The microprocessor 12 is connected to the movement sensor 18, 20 and the power source 22 and is capable of receiving, interpreting, storing and responding to the movement data based on user-defined operational parameters. Vock teaches in column 8, lines 3-22:

Briefly, the invention shown in FIG. 1 operates as follows. The housing 24 is attached or mounted to a sporting device, such as a ski or mountain bike, such that a user of the ski or mountain bike can access the system 10. During motion of the ski or mountain bike, the speed sensor 18 sends velocity information (over communication line 11a) to the microprocessor subsystem 12; while the loft sensor 20 sends loft or "air" time information (over communication line 11b) to the microprocessor subsystem 12. The speed information and loft time information are processed by the microprocessor subsystem 12 to quantify actual

speed, e.g., in miles per hour, and actual loft time, e.g., in seconds. The actual speed and loft time are thereafter stored in internal memory 13 until, at least, the speed and time data are accessed by a user of the system 10. Upon access through the user interface 14 (communicating with the microprocessor subsystem 12 via communication line 11c), a user of the system 10 can command the display of the speed and loft time data (sent across communication line 11d) on the display 16 in order to evaluate his or her performance in the sporting activity.

The user, through the user interface 14, commands the microprocessor 12 to display the speed and loft time data on the display 16 in order to evaluate his or her performance in the sporting activity.

Vock also teaches a clock element in column 3, lines 17-21:

Preferably, the microprocessor subsystem of the invention includes a [clock] element, e.g., a 24-hour clock, for providing information convertible to an elapsed time. Accordingly, the subsystem can perform various calculations, e.g., dead time, on the data acquired by the apparatus for display to a user.

The clock of Vock is used for calculating the various elapsed times however, providing a clock that can also associate dates as well as time of day to the movement data, the user can thereby collect data over days, weeks or months to track performance over time. Such would have been an obvious provision to one of ordinary skill in the art as exemplified by Burdea.

Burdea is cited to teach the convention of storing data for statistical purposes by including a time stamp associated with the data thereby providing historical progress, see column 6, lines 30-33. Any conventional means to tag a date and time stamp to the movement data for providing statistical information over time would have been obvious to one of ordinary skill. A real-time clock is a well-known example of a means to provide a date and time stamp. It would have been obvious to one of ordinary skill in the art to modify Vock to include a time/date stamp as taught by Burdea such as real-time clock in order to track the movement data over time.

Vock teaches many different embodiments for the speed sensor and the loft sensor. In column 20, lines 27-30, six accelerometers are used:

Specifically, six accelerometers are connected with various sensitive orientations to collect pitch 207a yaw 207b, roll 207c, surge 207d, heave 207e, and sway 207f accelerations.

Vock also teaches how to derive speed and direction in column 20, line 62 to column 21, lines 1-5:

Also shown in FIG. 14A are translational integrators 209a-209c which convert the compensated accelerations from inputs 207d-207f to translational velocities by integration. Integrators 210a-210c likewise integrate inputs of pitch 207a, yaw 207b, and roll 207c to angular velocity while integrators 211a-211c provide a further integration to convert the angular velocities to angular position. The angular positional information and translational velocity information is combined and processed at the speed and direction resolution section 212 to derive speed and direction.

The accelerometers 207d-207f are used to determine the angular positional information and translational velocity information. The angular positional information and the velocity information is combined and processed at the speed and direction resolution section 212 to derive speed and direction.

Additionally, Vock teaches in lines 58-62 of column 17:

It should be clear to those skilled in the art that fewer, or greater, numbers of accelerometers are within the scope of the invention, so long as they collectively determine speed. In effect, the fewer number of accelerometers results in reduced accuracy; not reduced functionality. Rather, in an ideal situation, one accelerometer can be used to detect speed; which is the integral of the acceleration over time. Further, a double integration over the same period provides distance; and, therefore, the invention can also provide distance in at least one embodiment of the invention.

The movement data of any one accelerometer can be used to determine speed and distance through integration and double integration, respectively.

Sensor 20 is a loft sensor that detects when the skier is in the air during a jump. The loft sensor 20 may be constructed by several known components. Preferably, the sensor 20 is either an accelerometer or a microphone assembly. FIG. 4 illustrates a graph 70 of a representative vibrational spectrum 72 that is stored into the microprocessor subsystem 12. Vock 12:22-30:

The vibrational spectrum between t_1 and t_2 [in FIG. 4] is comparatively smooth as compared to the spectrum outside this region because the user's sporting vehicle (e.g., the ski or mountain bike) is in the air and is not therefore subjected to the random vibrations of the road or ski slope. Accordingly, this relatively smooth spectrum between t_1 and t_2 can be readily discerned from the rest of the spectrum by the microprocessor subsystem 12 and evaluated for "air" time: specifically, "air" time is t_2-t_1 .

Regarding the new claim language added in the last amendment, the Vock device is for "detecting a first user-defined event [such as a first run down the mountain] based on at least one of the user-defined operation parameters and the movement data" that records the physical activity that occurs from the top of the run to the bottom of the run. Vock teaches 9:30-34:

A user presses the start/stop button 58 at the start of activity--such as at the start of skiing down a slope or biking down a trail--and presses the button 58 at the completion of activity to cease the acquisition of data

The at least one user-defined operational parameter is a predetermined threshold when the user at the top of the run predetermines when the threshold occurs at the end of the run. At the end of the run, the user pushes button 58 a second time to stop recording movement data. When the user stops recording movement data, the microprocessor, in response thereto, stores the movement data along with the time stamp as taught by Burdea. The time stamp accurately stores the time in which the user-defined event occurred at the end of the run. Therefore, the modified Vock device is for "storing first event information related to the detected first user-

defined event along with first time stamp information reflecting a time at which the first user-defined event occurred” as claimed.

Claim 13, recites, in addition to the limitations of claim 1, an input/output port, a computer capable of interpreting and reporting the movement data based on operational parameters, and a download device connected to the movement measuring device and the computer for transmitting the movement data and operational parameters between the movement measuring device and the computer for analysis, reporting and operation purposes.

Vock teaches at least one user input 14 connected to the microprocessor 12 for controlling the operation of the device.

Vock teaches an output indicator 16.

Burdea teaches 4:47-50:

Remote workstation 20 can be used at a medical specialist location for receiving diagnostic information and communicating rehabilitation instructions to computer workstation 14.

The remote workstation 20 is a computer running a program capable of interpreting and reporting said movement data based on the operational parameters. The program can generate reports of the user’s progress for analysis.

Burdea teaches network 22 that provides communication between the workstation 14 and the remote workstation 20. Obviously, the workstation 14 and workstation 20 include input/output ports in order to communicate with each other. The download device is the network interface card which allows transmitting the movement data and operational parameters between the movement measuring device and the remote computer for analysis, reporting and operation purposes.

Vock teaches the pressure sensor 221 determines the speed of vertical descent and the inclinometer 222 determines the angle. Since the angle of descent is known, and the rate of descent is known, the true speed is determined and displayed.

Regarding claim 20, Vock teaches a method to monitor physical movement of a body part comprising the steps of attaching a portable, self-contained movement measuring device 10 to the body part of the skis for measuring unrestrained movement in any direction. The sensors 221 and 222 measure data associated with the physical movement. The microprocessor 12 interprets the physical movement data based on user-defined operational parameters. As noted in claim 1, Vock teaches when the user stops recording movement data, the microprocessor, in response to the button 58 being pushed a second time, stores the movement data along with the time stamp as taught by Burdea. The time stamp accurately stores the time in which the user-defined event occurred at the end of the run.

As noted above in claim 1, Vock teaches a clock element for measuring elapsed time. Burdea teaches a method of storing the movement data along with time stamp information in memory. Burdea would inherently include a clock element in order to provide time and date information to be stored along with the movement data in memory 13 for developing historical data for a person to analyze. The modified Vock device would store in memory the first event information related to the detected first user-defined event along with first time stamp information reflecting a time at which the first user-defined event occurred.

The method further includes a microprocessor for detecting a first user-defined event based on at least one of the user-defined operational parameters and the movement data that

records the physical activity that occurs from the top of the run to the bottom of the run, see Vock 9:30-34.

Regarding claim 21, Vock teaches using pressure sensors 221 to determine speed and inclinometers 222 to determine the angle. The angle data would be taken along two orthogonal axes i.e., horizontal and vertical.

Regarding claim 31, the microprocessor stores in memory the date associated with the first time stamp.

Regarding claim 32, the microprocessor 12 retrieves the time stamp, as taught by Burdea, with the date from the “real-time clock” to associate the time stamp with the first user-defined event.

Regarding claim 33, the microprocessor 12 retrieves the time stamp, as taught by Burdea, from the “real-time clock” based on the occurrence of the user defined event.

Regarding claims 35, 79, 122, Vock teaches 16:25-29:

The subsystem 150 stores information about the user's activity in memory. This memory may be external to the CPU 152, such as shown as memory 154, but preferably resides in the RAM 152c. The memory may be nonvolatile such as battery backed RAM or Electrically Erasable Programmable Read Only Memory (EEPROM).

Vock teaches conventional memory includes nonvolatile memory such as battery backed RAM or Electrically Erasable Programmable Read Only Memory (EEPROM). Such is well-known to the artisan of ordinary skill. EEPROM is a well-known form of Read Only Memory used to store data that must be saved when power is removed. Therefore, the memory continues to store movement data in response to battery power being lost from said power source.

Regarding claims 36, 37, 80, 81, 123, 124, Vock teaches in column 8, lines 6-17:

During motion of the ski or mountain bike, the speed sensor 18 sends velocity information (over communication line 11a) to the microprocessor subsystem 12; while the loft sensor 20 sends loft or "air" time information (over communication line 11b) to the microprocessor subsystem 12. The speed information and loft time information are processed by the microprocessor subsystem 12 to quantify actual speed, e.g., in miles per hour, and actual loft time, e.g., in seconds. The actual speed and loft time are thereafter stored in internal memory 13 until, at least, the speed and time data are accessed by a user of the system 10.

The movement sensors 18 and 20 will continuously transmit movement data to the microprocessor 12. The speed and loft time information are processed by the microprocessor 12 to quantify actual speed in miles per hour and actual loft time in seconds where the actual speed and loft times are thereafter stored in internal memory 13.

Regarding claims 38, 82, 125, 129, the output indicator 16 is configured to display the results of the first user-defined event or run including speed and loft or "air" time based on the detection of the first user-defined event as predetermined by the user, 9:30-34.

Regarding claims 39, 40, 83, 84, 126, 127, the same display 16 would display information signaling the occurrence of the first user-defined event based on the detection of the first user-defined event and the first time stamp information. As set forth in claim 1, when the microprocessor detect the parameter that determines the end of the physical activity Burdea teaches storing a time/date stamp with the physical activity data and displaying the results.

Regarding claims 41, 85, 128, Vock teaches in column 9, lines 30-33:

A user presses the start/stop button 58 at the start of activity--such as at the start of skiing down a slope or biking down a trail--and presses the button 58 at the completion of activity to cease the acquisition of data

One of the user-defined operational parameters is a predetermined threshold when the user stops the acquisition of data. The microprocessor detects this predetermined threshold when

the button 58 being pressed a second time signaling the occurrence of the first user-defined event when the movement data reaches the predetermined threshold.

Regarding claims 42, 86, Vock teaches in column 2, line 66 to column 3, line 3:

a user interface for providing external inputs to the apparatus, including one or more of the following: a start/stop button for selectively starting and stopping the acquisition of data by the apparatus

The predetermined threshold is met when the user presses the start/stop button a second time to stop the acquisition of data. The output indicator 16 is configured to display the results of the run such as speed and loft time.

Regarding claims 43, 87, 130, Vock teaches in 8:11-15:

The speed information and loft time information are processed by the microprocessor subsystem 12 to quantify actual speed, e.g., in miles per hour, and actual loft time, e.g., in seconds. The actual speed and loft time are thereafter stored in internal memory 13

Memory 13 stores the first event information indicating the threshold is met.

Regarding claims 44, 75, 76, 88, 131, Burdea teaches adding a time/date stamp with the first event information where the microprocessor retrieves the time/date stamp and stores it with the first user-defined event information in memory 13. The microprocessor obviously has to retrieve the time/date from the “real-time clock”.

Regarding claims 45, 89, 132, in the art of portable battery operated devices, it is well-known to an artisan of ordinary skill to provide some indication that the battery power is getting low.

Regarding claims 46, 90, the output indicator can include LCD and LED displays, see Vock, column 2, lines 30-31.

Regarding claims 47, 91, the movement data stored in memory is configured to be downloaded to a computer as shown in figure 22. The information is downloaded to the base 608 that includes a computer, 26:18.

Regarding claims 48, 92, as noted above, Burdea teaches remote workstation 20 can be coupled over network 22 to computer workstation 14. Obviously, computer workstation 14 has software configured to communicate with external software in the remote workstation 20 wherein the external software is configured to present the downloaded movement data to the user in the display. It would have been obvious to modify Vock to download the physical activity from the local microprocessor to an external computer over a network as taught by Burdea in order to have the information saved at a different location so the information can be analyzed and processed for improving the user's performance.

Regarding claims 49, 50, 93, as noted above, Burdea taught the external software in the remote computer 20 is configured to run on the external computer where it can be analyzed by the user.

Regarding claims 51, 94, 136, 137, 138, 139, 140, the external software is configured to interpret the movement data and produce at least one report. The purpose of the external computer is to analyze the data and to communicate new instructions for the user to the local workstation 14. Producing reports using the movement data including historical data would be obvious to one of ordinary skill in the art in order to enhance the performance of the user. Burdea teaches, column 4, lines 43-50, the workstation 14 is coupled to hard copy device 18 for producing a hard copy of diagnostic information including rehabilitation progress charts. The

external computer would also be capable of generating reports. Such would have been an obvious provision in Vock.

Regarding claims 52, 95, 140, the external software is configured to interpret the movement data and produce at least one history report. The purpose of the external computer is to analyze the historical data. Producing reports on the movement data including historical data would be obvious to one of ordinary skill in the art in order to develop new instructions for the user.

Regarding claims 53, 96, the history report obviously includes dates and time of the movement data. It is important to include the dates and times in order to view historical changes in the user's development in order to generate a new training program for the user.

Regarding claims 54, 97, the external software is configured to allow the user to program additional reports and histories with respect to the movement data. If it can generate one report and one history report, it can generate a plurality of reports and histories.

Regarding claims 55, 98, 141, the movement data is configured to be downloaded to the computer via a wired connection. Burdea teaches network 22 is a wired connection.

Regarding claims 56, 99, 142, wireless connections are old and well known and an obvious equivalent means of communicating information over air waves.

Regarding claims 58, 101, 144, the output indicator provides a visual indicator to the user regarding the threshold being met. Displays 16, 52, 162, 630 would display the loft or "air" time, speed of the user, distance traveled, etc. based on the microprocessor determining that the threshold is met.

Regarding claims 60, 61, 104, 146, 147, the memory stores the user-defined operational parameters comprising a plurality of thresholds respectively corresponding to a plurality of notifications. One type of operational parameters occurs each time the loft or “air” time event happens. It includes the smooth vibrational spectrum threshold between t1 and t2 as shown in figure 4. Each time the movement data reaches this threshold, the microprocessor is configured to detect that the loft or “air” time user-defined event has occurred. The microprocessor is configured to calculate the actual loft or “air” and store it in memory and will send the information to the output indicator to display the loft or "air" time data indicating that the user-defined loft or “air” time event has occurred.

Regarding claims 64, 107, 150, the plurality of thresholds are different from each other because they are collected at different times and represent different jumps. Moreover, the plurality of thresholds would also include speed.

Regarding claims 65, 108, 151, the plurality of notifications have different visual indicators because one measures speed and another measures loft time.

Regarding claims 66, 109, 152, the prior art has already established the convention of using visual indicators to display different results. Using a blinking indicator is old and well known and an obvious provision in the art of displaying information on a display screen in order to highlight one particular piece of data. Where the general conditions of a claim are disclosed in the prior art, it is not inventive to discover the optimum or workable ranges by routine experimentation. *In re Swain et al.*, 33 CCPA (Patents) 1250, 156 F.2d 239, 70 USPQ 412; *Minnesota Mining and Mfg. Co. v. Coe*, 69 App. D.C. 217, 99 F.2d 986, 38 USPQ 213; *Allen et al. v. Coe*, 77 App. D.C. 324, 135 F.2d 11, 57 USPQ 136. Providing blinking lights to highlight

a portion of the display is well within the realm of the artisan of ordinary skill in the art of displaying information on a display screen.

Regarding claims 68, 111, the microprocessor is configured to detect occurrence of the first user-defined event by comparing the movement data to the predetermined threshold which occurred when the user pressed the start/stop button 58 a second time.

Regarding claims 69, 112, 155, Vock teaches in column 21, lines 31-35, the device can be mounted to the user. Therefore, the device is capable of being placed on the user's arm and still be able to perform the function of recording the speed of the user, for example.

Regarding claims 70, 113, 155, with the device attached to the user's arm the sensor measures movement of the user's arm along with the user's body which will measure the speed of the user.

Regarding claims 71, 72, 114, 115, the movement sensor measures distance as well as speed. Vock teaches in column 20, lines 6-9, "one accelerometer can be used to detect speed; which is the integral of the acceleration over time. Further, a double integration over the same period provides distance". Therefore, the movement sensor of Vock would also measure distance. The distance is the same whether the user is walking, skiing or biking.

Regarding claims 73, 116, 118-120, 123, 124, 134, 135, 158, as noted above, Burdea teaches including a time stamp for associating the time/date stamp with the movement data and user-defined events for providing a time history of updates of the user performance for storing in memory. The microprocessor also stores in memory the date associated with the time stamp.

The microprocessor also continuously checks movement data received from the movement sensor after the user presses the start button, Vock 8:6-17.

The output indicator is configured to display information signaling the occurrence of the first user-defined event based on the detection of the first user-defined event and the first time stamp information.

The movement data stored in memory is configured to be downloaded to the computer 14, 20.

Software is configured to communicate with external software configured to run on a computer 14, 20 and present the downloaded movement data.

The external software is configured to produce at least one report based on the movement data.

The memory stores a plurality of user-defined thresholds for the loft or “air” time and speed, for example. The plurality of thresholds corresponds to a plurality of notifications such as loft or “air” time and speed. Each time the movement data reaches one of the plurality of thresholds, the microprocessor is configured to detect that one of the user-defined events occurred.

The sensor can be mounted on the arm of the user and measures the movement of the user’s arm to determine the speed of the user.

Regarding claim 77, as noted above, Burdea teaches including a time stamp for associating the time/date stamp with the movement data so as to provide a time history of the user performance to be stored in memory.

Regarding claim 103, memory is configured to store the user-defined operational parameters and a plurality of thresholds respectively corresponding to a plurality of notifications.

Each time the movement data reaches one of the thresholds such as loft or "air" time, the microprocessor is configured to detect that one of a plurality of user-defined events occurred.

Regarding claim 104, the output indicator 16, 52, 162, 274, 630, 744a, is configured to display a corresponding notification indicating that one of the user-defined events has occurred such as loft time.

Regarding claim 110, the output indicator 16, 52, 162, 274, 630, 744a, is configured to signal the occurrence of user-defined events such as loft time and speed.

Regarding claims 125-128, as noted above, Burdea teaches including a time stamp for associating the time/date stamp with the movement data so as to provide a time history of the user performance to be stored in memory. The output indicator or displays 16, 52, 162, 630 are configured to signal the occurrence of user-defined events such as speed and loft time which is based on movement data.

Regarding claim 129, the output indicator will signal the occurrence of the first user-defined event when the movement data reaches the predetermined threshold at the end of the run. At least one of the plurality of thresholds set by the user such as loft or "air" time or speed which the output indicator will display.

Regarding claim 130, memory stores the first event information indicating that the predetermined threshold is met at the end of the physical activity.

Regarding claim 131, the microprocessor records the time and date of the threshold being met. The microprocessor records the time and date for all movement data.

Regarding claims 133-135, Vock teaches in 8:11-15:

The speed information and loft time information are processed by the microprocessor subsystem 12 to quantify actual speed, e.g., in miles per hour, and

actual loft time, e.g., in seconds. The actual speed and loft time are thereafter stored in internal memory 13

The physical movement data stored in memory is the interpreted physical movement data such as speed and loft time, and the stored physical movement data is configured to be downloaded to a computer as taught by Burdea. The external software is configured to run on the computer.

Regarding claims 136-140, Burdea teaches 4:43-50 producing reports based on the interpreted physical movement data using external software. Since the movement data includes time/date stamps, history reports can also be generated. Additional reports and histories with respect to the interpreted physical movement data can be generated. The additional reports and histories can be programmed by the user via external software. All of the means to generate reports are taught by the prior art. Whether the reports are created by a specialist in the art or by a user is well within the realm of the artisan of ordinary skill.

Regarding claim 153, Vock teaches signaling the occurrence of a user-defined event such as speed or loft time which is based on the threshold being met.

Regarding claim 154, Vock teaches at least one of the user-defined operational parameters is a predetermined threshold for determining speed and loft time, and the first user-defined event occurs when the movement data reaches the predetermined threshold as set forth at the end of the run. The detecting comprises comparing the physical movement data to the predetermined threshold at the end of the run.

Regarding claim 156, Vock teaches measuring the movement data to determine the speed or loft time of the portable, self-contained movement measuring device.

Regarding claims 159, 174 and 190, the user-defined operational parameters comprise a first predetermined threshold which is when the user has set the predetermined threshold for the first user-defined event e.g., when the user makes a jump. The first predetermined threshold is when the user leaves the ground where the movement data is relatively smooth as shown in figure 4 at 72. The microprocessor interprets the smooth portion of the movement data as the first user-defined event.

A second predetermined threshold different from the first predetermined threshold is speed. The second user-defined event occurs when the movement data reaches the second predetermined threshold. Vock teaches 2:45-50:

One preferred aspect of the invention includes a speed sensor, connected to the microprocessor subsystem, which senses a third condition that is indicative of a velocity of the vehicle. In this aspect, the microprocessor subsystem includes means for converting the third condition to information representative of a speed of the vehicle.

The microprocessor is configured to interpret said movement data to determine whether the movement data reaches the first predetermined threshold which is when the movement data is relatively smooth as noted above and to determine whether it senses a third condition that is indicative of the velocity.

Regarding claims 160, 175, 176, 191, 192, the output indicator is configured to display first information indicating the occurrence of the first user-defined event when it is determined that the first predetermined threshold is met such as loft or “air” time.

The output indicator is also configured to display second information indicating the occurrence of the second user-defined event when is determined that the second predetermined threshold is met such as speed of the user.

Regarding claims 161, the displayed first information, i.e., loft or “air” time, is different from the displayed second information i.e., speed.

Regarding claims 163, 178, 194, the first user-defined event is a predetermined type of movement such as a run down the mountain.

Regarding claims 168, 183, 199, the microprocessor of Vock is configured to detect a second event or run down the mountain based on at least one of the user-defined operational parameters, where the user stops collection of movement data, and the movement data at the end of the run. The microprocessor is configured to store, in said memory, second event information related to the detected second event along with second time stamp information reflecting a time at which the second event occurred at the end of the run.

Regarding claims 169, 184, 200, the second event is a predetermined type of movement such as a second run down the mountain.

THIS ACTION IS MADE FINAL.

Patent owner’s amendment filed 14 October 2014 necessitated the new grounds of rejection presented in this Office action. Accordingly, **THIS ACTION IS MADE FINAL**. See MPEP § 706.07(a).

A shortened statutory period for response to this action is set to expire 2 Months from the mailing date of this action.

Extensions of time under 37 CFR 1.136(a) do not apply in reexamination proceedings. The provisions of 37 CFR 1.136 apply only to “an applicant” and not to parties in a reexamination proceeding. Further, in 35 U.S.C. 305 and in 37 CFR 1.550(a), it is required that reexamination proceedings “will be conducted with special dispatch within the Office.”

Extensions of time in reexamination proceedings are provided for in 37 CFR 1.550(c). A request for extension of time must specify the requested period of extension and it must be accompanied by the petition fee set forth in 37 CFR 1.17(g). Any request for an extension in a third party requested *ex parte* reexamination must be filed on or before the day on

which action by the patent owner is due, and the mere filing of a request will not effect any extension of time. A request for an extension of time in a third party requested *ex parte* reexamination will be granted only for sufficient cause, and for a reasonable time specified. Any request for extension in a patent owner requested *ex parte* reexamination for up to two months from the time period set in the Office action must be filed no later than two months from the expiration of the time period set in the Office action. A request for an extension in a patent owner requested *ex parte* reexamination for more than two months from the time period set in the Office action must be filed on or before the day on which action by the patent owner is due, and the mere filing of a request for an extension for more than two months will not effect the extension. The time for taking action in a patent owner requested *ex parte* reexamination will not be extended for more than two months from the time period set in the Office action in the absence of sufficient cause or for more than a reasonable time.

The filing of a timely first response to this final rejection will be construed as including a request to extend the shortened statutory period for an additional month, which will be granted even if previous extensions have been granted. In no event, however, will the statutory period for response expire later than SIX MONTHS from the mailing date of the final action. See MPEP § 2265.

Amendment in Reexamination Proceedings

In any reexamination proceeding under this chapter, the patent owner will be permitted to propose any amendment to his patent and a new claim or claims thereto, in order to distinguish the invention as claimed from the prior art cited under the provisions of section 301 of this title, or in response to a decision adverse to the patentability of a claim of a patent. See 35 U.S.C. 305. **For this reason, patent owner is notified that *any* amendment to a claim not involved in the reexamination proceeding may not be entered, and if entered, will bring that claim into the reexamination proceeding.** See 37 CFR 1.104.

Patent owner is also notified that any proposed amendment to the specification and/or claims in this reexamination proceeding must comply with 37 C.F.R. 1.530(d)-(j), must be formally presented pursuant to 37 C.F.R. 1.52(a) and (b), and must contain any fees required by 37 C.F.R. 1.20(c). See MPEP § 2250(IV) for examples to assist in the preparation of proper proposed amendments in reexamination proceedings. Also, in accordance with 37 CFR 1.530(e), each claim amendment must be accompanied by an explanation of the support in the disclosure of the patent for the amendment (i.e., support for the changes made in the claim(s), support for any insertions and deletions). The failure to submit an explanation will generally result in a noncompliant response since the failure to set forth the support in the disclosure goes to the merits of the case (see MPEP § 2266.01). Such an amendment submitted after final rejection will not be entered.

Notification of Concurrent Proceedings

The patent owner is reminded of the continuing responsibility under 37 C.F.R. 1.565(a) to apprise the Office of any litigation activity, or other prior or concurrent proceeding, involving the patent throughout the course of this reexamination proceeding. Likewise, if present, the third party requester is also reminded of the ability to similarly apprise the Office of any such activity or proceeding throughout the course of this reexamination proceeding. See MPEP §§ 2207, 2282 and 2286.

Service of Papers

After filing of a request for *ex parte* reexamination by a third party requester, any document filed by either the patent owner or the third party requester must be served on the other party (or parties where two or more third party requester proceedings are merged) in the reexamination proceeding in the manner provided in 37 CFR 1.248. The document must reflect service or the document may be refused consideration by the Office. See 37 CFR 1.550(f).

Conclusion

All correspondence relating to this *ex parte* reexamination proceeding should be directed:

By EFS: Registered users may submit via the electronic filing system EFS-Web, at <https://efs.uspto.gov/efile/myportal/efs-registered>.

By Mail to: Mail Stop *Ex Parte* Reexam
Central Reexamination Unit
Commissioner for Patents
United States Patent & Trademark Office
P.O. Box 1450 Alexandria, VA 22313-1450

By FAX to: (571) 273-9900
Central Reexamination Unit

By hand: Customer Service Window
Randolph Building
401 Dulany Street
Alexandria, VA 22314

For EFS-Web transmissions, 37 CFR 1.8(a)(1)(i) (C) and (ii) states that correspondence (except for a request for reexamination and a corrected or replacement request for reexamination) will be considered timely filed if (a) it is transmitted via the Office's electronic- filing system in accordance with 37 CFR 1.6(a)(4), and (b) includes a certificate of transmission for each piece of correspondence stating the date of transmission, which is prior to the expiration of the set period of time in the Office action.

Any inquiry concerning this communication or earlier communications from the Examiner, or as to the status of this proceeding, should be directed to the Central Reexamination Unit at telephone number (571) 272-7705.

Telephone Number for reexamination inquiries:

Reexamination and Amendment Practice	(571) 272-7703
Central Reexam Unit (CRU)	(571) 272-7705
Reexamination Facsimile Transmission No.	(571) 273-9900

/Danton DeMille/
Patent Reexamination Specialist
Central Reexamination Unit 3993
(571) 272-4974
9 December 2014

Conferee: /RMF/

Conferee: /EDL/

Office Action in Ex Parte Reexamination	Control No. 90/013,201	Patent Under Reexamination 6059576	
	Examiner DANTON DE MILLE	Art Unit 3993	AIA (First Inventor to File) Status No

-- The MAILING DATE of this communication appears on the cover sheet with the correspondence address --

- a. Responsive to the communication(s) filed on 10/14/2014.
 A declaration(s)/affidavit(s) under 37 CFR 1.130(b) was/were filed on _____.
- b. This action is made FINAL.
- c. A statement under 37 CFR 1.530 has not been received from the patent owner.

A shortened statutory period for response to this action is set to expire 2 month(s) from the mailing date of this letter. Failure to respond within the period for response will result in termination of the proceeding and issuance of an *ex parte* reexamination certificate in accordance with this action. 37 CFR 1.550(d). **EXTENSIONS OF TIME ARE GOVERNED BY 37 CFR 1.550(c).** If the period for response specified above is less than thirty (30) days, a response within the statutory minimum of thirty (30) days will be considered timely.

Part I THE FOLLOWING ATTACHMENT(S) ARE PART OF THIS ACTION:

- | | |
|--|---|
| 1. <input type="checkbox"/> Notice of References Cited by Examiner, PTO-892. | 3. <input type="checkbox"/> Interview Summary, PTO-474. |
| 2. <input type="checkbox"/> Information Disclosure Statement, PTO/SB/08. | 4. <input type="checkbox"/> _____. |

Part II SUMMARY OF ACTION

- 1a. Claims 1,13,20,21,31-33,35-56,58,60,61,64-66,68-73,75-77,79-99,101,103,104,107-116,118-120,122-142,144,146,147 and 150-204 are subject to reexamination.
- 1b. Claims 2-12,14-19 and 22-29 are not subject to reexamination.
2. Claims 30,34,57,59,62,63,67,74,78,100,102,105,106,117,121,143,145,148 and 149 have been canceled in the present reexamination proceeding.
3. Claims 162,164-167,170-173,177,179-182,185-188,193,195-198 and 201-204 are patentable and/or confirmed.
4. Claims 1,13,20,21,31-33,35-56,58,60,61,64-66,68-73,75-77,79-99,101,103,104,107-116,118-120,122-142,144,146,147,150-161,163,168,169,174-176,178,183,184,189-192,194,199 and 200 are rejected.
5. Claims _____ are objected to.
6. The drawings, filed on _____ are acceptable.
7. The proposed drawing correction, filed on _____ has been (7a) approved (7b) disapproved.
8. Acknowledgment is made of the priority claim under 35 U.S.C. § 119(a)-(d) or (f).
a) All b) Some* c) None of the certified copies have
1 been received.
2 not been received.
3 been filed in Application No. _____ .
4 been filed in reexamination Control No. _____ .
5 been received by the International Bureau in PCT application No. _____ .
* See the attached detailed Office action for a list of the certified copies not received.
9. Since the proceeding appears to be in condition for issuance of an *ex parte* reexamination certificate except for formal matters, prosecution as to the merits is closed in accordance with the practice under *Ex parte* Quayle, 1935 C.D. 11, 453 O.G. 213.
10. Other: _____

cc: Requester (if third party requester)

U.S. Patent and Trademark Office

PTOL-466 (Rev. 08-13)

Office Action in Ex Parte Reexamination

Part of Paper No. 20141021

Reexamination 	Application/Control No.	Applicant(s)/Patent Under Reexamination
	90/013,201	6059576
	Certificate Date	Certificate Number

Requester	Correspondence Address:	<input checked="" type="checkbox"/> Patent Owner	<input type="checkbox"/> Third Party
<p>SUGHRUE MION, PLLC 2100 PENNSYLVANIA AVENUE, N.W. SUITE 800 WASHINGTON, DC 20037</p>			

LITIGATION REVIEW <input checked="" type="checkbox"/>	/DDD/	12/3/2014
	(examiner initials)	(date)
Case Name		Director Initials
NONE		

COPENDING OFFICE PROCEEDINGS	
TYPE OF PROCEEDING	NUMBER
1. NONE	
2.	
3.	
4.	

Search Notes 	Application/Control No. 90013201	Applicant(s)/Patent Under Reexamination 6059576
	Examiner DANTON DEMILLE	Art Unit 3993

CPC- SEARCHED		
Symbol	Date	Examiner

CPC COMBINATION SETS - SEARCHED		
Symbol	Date	Examiner

US CLASSIFICATION SEARCHED			
Class	Subclass	Date	Examiner

SEARCH NOTES		
Search Notes	Date	Examiner
See Attached Search Notes	12/2/14	/DDD/
Reviewed Patented File's Prosecution History	12/2/14	/DDD/

INTERFERENCE SEARCH			
US Class/ CPC Symbol	US Subclass / CPC Group	Date	Examiner

--	--

EAST Search History

EAST Search History (Prior Art)

Ref #	Hits	Search Query	DBs	Default Operator	Plurals	Time Stamp
S11	8	("5636146" "6018705" "6266623").PN.	US-PGPUB; USPAT; USOCR; FPRS; EPO; JPO; DERWENT	OR	OFF	2014/04/14 11:37
S20	11555355	low battery	US-PGPUB; USPAT; USOCR; FPRS; EPO; JPO; DERWENT	OR	OFF	2014/04/14 14:20
S21	4	S20 and S11	US-PGPUB; USPAT; USOCR; FPRS; EPO; JPO; DERWENT	OR	OFF	2014/04/14 14:20
S22	23065	low battery	US-PGPUB; USPAT; USOCR; FPRS; EPO; JPO; DERWENT	ADJ	OFF	2014/04/14 14:21
S23	0	S22 and S11	US-PGPUB; USPAT; USOCR; FPRS; EPO; JPO; DERWENT	ADJ	OFF	2014/04/14 14:21
S24	4	(download remot\$4 transmi\$5) and S11	US-PGPUB; USPAT; USOCR; FPRS; EPO; JPO; DERWENT	OR	OFF	2014/04/14 14:42
S26	5	("5636146" "6018705" "6266623" "5348519" "4655928").PN.	USPAT	OR	OFF	2014/04/15 10:18
S27	2	dock\$5 and S26	USPAT	OR	OFF	2014/04/15 10:19
S28	2	(ir or infrared) and S26	USPAT	OR	OFF	2014/04/15 10:26
S29	5	("5636146" "6018705" "6266623" "5348519" "4655928").PN.	USPAT	OR	OFF	2014/04/15 15:47
S30	34126	(time or day) adj3 stamp	USPAT	OR	OFF	2014/04/15 16:47
S31	2067	(601/5,23-40).ccls.	USPAT	OR	OFF	2014/04/15 16:50
S32	3	S30 and S31	USPAT	OR	OFF	2014/04/15 16:50
S33	3231	(600/587-595).ccls.	USPAT	OR	OFF	2014/04/15 16:53
S34	52	S30 and S33	USPAT	OR	OFF	2014/04/15 16:53
S37	29796	"482".clas.	US-PGPUB; USPAT; USOCR	ADJ	ON	2014/04/15 17:00
S39	3166	702/33,41-44,56.ccls.	US-PGPUB; USPAT; USOCR	ADJ	ON	2014/04/15 17:32

12/ 2/ 2014 4:36:17 PM

C:\Users\ddemille\Documents\EAST\Workspaces\90013201.wsp

REEXAMINATION

IN THE UNITED STATES PATENT AND TRADEMARK OFFICE

In re Patent of

Docket No: A209779

Theodore L. Brann

Control No.: 90/013,201

Group Art Unit: 3993

Confirmation No.: 9930

Examiner: DEMILLE, DANTON D

Filed: April 4, 2014

For: TRAINING AND SAFETY DEVICE, SYSTEM AND METHOD TO AID IN PROPER
MOVEMENT DURING PHYSICAL ACTIVITY

RESPONSE TO EX PARTE REEXAMINATION OFFICE ACTION

MAIL STOP *Ex Parte* Reexam

Attn: Central Reexamination Unit

Commissioner for Patents

P.O. Box 1450

Alexandria, VA 22313-1450

Sir:

In response to the Office Action dated August 13, 2014, Patent Owner respectfully requests reconsideration of this reexamination application in light of the following amendments and remarks.

It is noted that October 13, 2014 was a federal holiday and thus the USPTO was closed. Accordingly, this Response is being timely filed on October 14, 2014, within the shortened statutory period for responding within two months from the mailing date of August 13, 2014.

TABLE OF CONTENTS

I.	AMENDMENTS TO THE CLAIMS	2
II.	STATUS OF THE CLAIMS AND EXEMPLARY SUPPORT FOR CLAIM AMENDMENTS	41
III.	REMARKS	47

I. AMENDMENTS TO THE CLAIMS

This listing of claims will replace all prior versions and listings of claims in the proceeding:

LISTING OF CLAIMS:

1. (currently amended): A portable, self-contained device for monitoring movement of body parts during physical activity, said device comprising:

a movement sensor capable of measuring data associated with unrestrained movement in any direction and generating signals indicative of said movement;

a power source;

a microprocessor connected to said movement sensor and to said power source, said microprocessor capable of receiving, interpreting, storing and responding to said movement data based on user-defined operational parameters, detecting a first user-defined event based on at least one of the user-defined operational parameters and the movement data, and storing first event information related to the detected first user-defined event along with first time stamp information reflecting a time at which the first user-defined event occurred;

at least one user input connected to said microprocessor for controlling the operation of said device;

a real-time clock connected to said microprocessor;

memory for storing said movement data; and

an output indicator connected to said microprocessor for signaling the occurrence of user-defined events;

wherein said movement sensor measures the angle and velocity of said movement.

RESPONSE TO *EX PARTE* REEXAMINATION OFFICE ACTION

Control No.: 90/013,201

Attorney Docket No.: A209779

2. (original): The device of claim 1 further comprising at least one input/output port connected to said microprocessor for downloading said data and uploading said operational parameters to and from a computer.

3. (original): The device of claim 1 wherein said device is compact and weighs less than one pound.

4. (original): The device of claim 1 wherein said movement sensor comprises at least one accelerometer.

5. (original): The device of claim 1 wherein said movement sensor can simultaneously detect real time movement along at least two orthogonal axes.

6. (original): The device of claim 1 wherein said movement sensor is housed separately from said microprocessor.

7. (original): The device of claim 1 wherein said monitored body part movement is torso or limb movement.

8. (original): The device of claim 1 wherein said data measured by said movement sensor includes the distance of said movement.

RESPONSE TO *EX PARTE* REEXAMINATION OFFICE ACTION

Control No.: 90/013,201

Attorney Docket No.: A209779

9. (original): The device of claim 1 wherein said output indicator is visual.

10. (original): The device of claim 1 wherein said output indicator is audible.

11. (original): The device of claim 1 wherein said output indicator is tactile.

12. (original): The device of claim 1 wherein said user input is a switch.

13. (currently amended): A system to aid in training and safety during physical activity, said system comprising

a portable, self-contained movement measuring device, said movement measuring device

further comprising

a movement sensor capable of measuring data associated with unrestrained movement in any direction and generating signals indicative of said movement;

a power source;

a microprocessor connected to said power source, said microprocessor capable of receiving, interpreting, storing and responding to said movement data based on user-defined

operational parameters, detecting a first user-defined event based on at least one of the user-defined operational parameters and the movement data, and storing first event information

related to the detected first user-defined event along with first time stamp information reflecting a time at which the first user-defined event occurred;

RESPONSE TO *EX PARTE* REEXAMINATION OFFICE ACTION

Control No.: 90/013,201

Attorney Docket No.: A209779

at least one user input connected to said microprocessor for controlling the operation of said device;

a real-time clock connected to said microprocessor;

memory for storing said movement data;

at least one input/output port connected to said microprocessor for downloading said data and uploading said operational parameters; and

an output indicator connected to said microprocessor;

a computer running a program capable of interpreting and reporting said movement data based on said operational parameters; and

a download device electronically connected to said movement measuring device and said computer for transmitting said movement data and operational parameters between said movement measuring device and said computer for analysis, reporting and operation purposes;

wherein said movement sensor measures the angle and velocity of said movement.

14. (original): The system of claim 13 wherein said computer is a personal computer.

15. (original): The system of claim 13 wherein said computer is connected to a network of other computers.

16. (original): The system of claim 13 wherein said download device is a physical docking station.

RESPONSE TO *EX PARTE* REEXAMINATION OFFICE ACTION

Control No.: 90/013,201

Attorney Docket No.: A209779

17. (original): The system of claim 13 wherein said download device is a wireless device.

18. (original): The system of claim 17 wherein said wireless device uses radio frequency.

19. (original): The system of claim 17 wherein said wireless device uses infrared light.

20. (currently amended): A method to monitor physical movement of a body part comprising the steps of:

attaching a portable, self-contained movement measuring device to said body part for measuring unrestrained movement in any direction;

measuring data associated with said physical movement;

interpreting, using a microprocessor included in the portable, self-contained movement measuring device, said physical movement data based on user-defined operational parameters and a real-time clock; [and]

storing said data in memory;

detecting, using the microprocessor, a first user-defined event based on at least one of the user-defined operational parameters and the movement data; and

storing, in said memory, first event information related to the detected first user-defined event along with first time stamp information reflecting a time at which the first user-defined event occurred.

RESPONSE TO *EX PARTE* REEXAMINATION OFFICE ACTION

Control No.: 90/013,201

Attorney Docket No.: A209779

21. (original): The method of claim 20 wherein said physical movement data includes velocity data of said movement, angle measurement data taken along at least two orthogonal axes, and related date and time data.

22. (original): The method of claim 21 further comprising the step of defining said parameters for a specific physical movement prior to said interpreting step.

23. (original): The method of claim 21 further comprising the step of downloading said data from said movement measuring device to a computer for reporting and analysis purposes.

24. (original): The method of claim 21 wherein said interpreting step comprises teaching an individual how to properly perform said physical movement.

25. (original): The method of claim 20 wherein said movement measuring device is an accelerometer.

26. (original): The method of claim 20 further comprising the step of providing real time feedback regarding said movement.

27. (original): The method of claim 26 wherein said physical movement is physical labor.

RESPONSE TO *EX PARTE* REEXAMINATION OFFICE ACTION
Control No.: 90/013,201
Attorney Docket No.: A209779

28. (original): The method of claim 26 wherein said physical movement is an exercise related to medical treatment.

29. (original): The method of claim 26 wherein said physical movement is an exercise to improve technique related to an athletic skill.

Cancel claim 30.

31. (new): The device of claim 1, wherein said microprocessor is configured to store, in said memory, date information associated with the first time stamp information.

32. (new): The device of claim 1, wherein said microprocessor is configured to retrieve said first time stamp information from said real-time clock and associate the retrieved first time stamp information with said first user-defined event.

33. (new): The device of claim 32, wherein said microprocessor is configured to retrieve said first time stamp information from said real-time clock based on the detection of the user-defined event.

Cancel claim 34.

35. (new): The device of claim 1, wherein said memory is configured to continue to store said movement data in response to battery power being lost from said power source.

36. (new): The device of claim 1, wherein said movement sensor is configured to continuously check for said movement.

37. (new): The device of claim 36, wherein said microprocessor is configured to continuously interpret, based on the user-defined operational parameters, said movement data received from said movement sensor.

38. (new): The device of claim 1, wherein said output indicator is configured to display information signaling the occurrence of the first user-defined event based on the detection of the first user-defined event.

39. (new): The device of claim 38, wherein said output indicator is configured to display said information signaling the occurrence of the first user-defined event based on said first time stamp information.

40. (new): The device of claim 1, wherein said output indicator is configured to display information signaling the occurrence of the first user-defined event based on the detection of the first user-defined event and the first time stamp information.

41. (new): The device of claim 1, wherein said at least one of the user-defined operational parameters is a predetermined threshold, and said first user-defined event occurs when the movement data reaches the predetermined threshold.

42. (new): The device of claim 41, wherein said output indicator is configured to display information signaling the occurrence of the first user-defined event when the movement data reaches the predetermined threshold.

43. (new): The device of claim 41, wherein said memory is configured to store said first event information indicating that the predetermined threshold is met.

44. (new): The device of claim 43, wherein said memory is configured to store the first time stamp information in association with said first event information.

45. (new): The device of claim 1, wherein said output indicator is configured to indicate a low battery condition of the device.

46. (new): The device of claim 9, wherein said output indicator is selected from the group consisting of single monochromatic LEDs, multiple colored lights, and liquid crystal displays.

47. (new): The device of claim 1, wherein said movement data stored in the memory is configured to be downloaded to a computer.

48. (new): The device of claim 47, further comprising:

software configured to communicate with external software, wherein the external software is configured to present the downloaded movement data to the user.

49. (new): The device of claim 48, wherein said external software is configured to run on the computer.

50. (new): The device of claim 49, wherein said downloaded movement data is configured to be analyzed by said user via said external software.

51. (new): The device of claim 48, wherein said external software is configured to interpret said movement data and produce at least one report.

52. (new): The device of claim 48, wherein said external software is configured to interpret said movement data and produce at least one history report.

53. (new): The device of claim 52, wherein said at least one history report includes dates and times of said movement data.

54. (new): The device of claim 48, wherein said external software is configured to allow the user to program additional reports and histories with respect to said movement data of said user.

55. (new): The device of claim 47, wherein said movement data is configured to be downloaded to said computer via a wired connection.

56. (new): The device of claim 47, wherein said movement data is configured to be downloaded to said computer via a wireless connection.

Cancel claim 57.

58. (new): The device of claim 41, wherein the output indicator is configured to provide a visual indicator to the user regarding the predetermined threshold being reached.

Cancel claim 59.

60. (new): The device of claim 1, wherein the memory is configured to store the user-defined operational parameters, the user-defined operational parameters comprising a plurality of thresholds respectively corresponding to a plurality of notifications, wherein each time the movement data reaches one of the plurality of the thresholds, the microprocessor is configured to detect that one of the user-defined events occurred.

61. (new): The device of claim 60, wherein when the microprocessor detects that one of the user-defined events occurred based on the movement data reaching one of the plurality of the

thresholds, the output indicator displays a corresponding one of the notifications indicating that one of the user-defined events has occurred.

Cancel claim 62.

Cancel claim 63.

64. (new): The device of claim 60, wherein the plurality of thresholds are different from each other.

65. (new): The device of claim 60, wherein the plurality of notifications are different visual indicators.

66. (new): The device of claim 65, wherein at least one of the visual indicators includes a blinking indicator.

Cancel claim 67.

68. (new): The device of claim 41, wherein said microprocessor is configured to detect occurrence of the first user-defined event by comparing said movement data to said predetermined threshold.

69. (new): The device of claim 1, wherein said device is configured to be placed on said user's arm to monitor and record said movement data.

70. (new): The device of claim 69, wherein said movement sensor is configured to measure movement of said user's arm.

71. (new): The device of claim 1, wherein said movement sensor is configured to measure a walking distance.

72. (new): The device of claim 71, wherein said device is configured to be wearable by the user, and said movement sensor is configured to measure said walking distance of said user.

73. (new): The device of claim 1, wherein said microprocessor is configured to store, in said memory, date information associated with the first time stamp information,

wherein said movement sensor is configured to continuously check for said movement, wherein said output indicator is configured to display information signaling the occurrence of the first user-defined event based on the detection of the first user-defined event and the first time stamp information,

wherein the device further comprises software configured to communicate with external software configured to run on a computer and present the downloaded movement data,

wherein said external software is configured to produce at least one report based on said movement data.

wherein the memory is configured to store the user-defined operational parameters, the user-defined operational parameters comprising a plurality of thresholds respectively corresponding to a plurality of notifications, wherein each time the movement data reaches one of the plurality of the thresholds, the microprocessor is configured to detect that one of the user-defined events occurred,

wherein said device is configured to be placed on said user's arm to monitor and record said movement data,

wherein said movement sensor is configured to measure movement of said user's arm.

Cancel claim 74.

75. (new): The system of claim 13, wherein said microprocessor is configured to store, in said memory, date information associated with the first time stamp information.

76. (new): The system of claim 13, wherein said microprocessor is configured to retrieve said first time stamp information from said real-time clock and associate the retrieved first time stamp information with said first user-defined event.

77. (new): The system of claim 76, wherein said microprocessor is configured to retrieve said first time stamp information from said real-time clock based on the detection of the first user-defined event.

Cancel claim 78.

79. (new): The system of claim 13, wherein said memory is configured to continue to store said movement data in response to battery power being lost from said power source.

80. (new): The system of claim 13, wherein said movement sensor is configured to constantly checks for said movement.

81. (new): The system of claim 80, wherein said microprocessor is configured to continuously interpret, based on the user-defined operational parameters, said movement data received from said movement sensor.

82. (new): The system of claim 13, wherein said output indicator is configured to display information signaling the occurrence of the first user-defined event based on the detection of the first user-defined event.

83. (new): The system of claim 82, wherein said output indicator is configured to display said information signaling the occurrence of the first user-defined event based on said first time stamp information.

84. (new): The system of claim 13, wherein said output indicator is configured to display information signaling the occurrence of the first user-defined event based on the detection of the first user-defined event and the first time stamp information.

85. (new): The system of claim 13, wherein said at least one of the user-defined operational parameters is a predetermined threshold, and said first user-defined event occurs when the movement data reaches the predetermined threshold.

86. (new): The system of claim 85, wherein said output indicator is configured to display information signaling the occurrence of the first user-defined event when the movement data reaches the predetermined threshold.

87. (new): The system of claim 85, wherein said memory is configured to store said first event information indicating that the predetermined threshold is met.

88. (new): The system of claim 87, wherein said memory is configured to store the first time stamp information in association with said first event information.

89. (new): The system of claim 13, wherein said output indicator is configured to indicate a low battery condition of the device.

90. (new): The system of claim 13, wherein said output indicator is visual, and said output indicator is selected from the group consisting of single monochromatic LEDs, multiple colored lights, and liquid crystal displays.

91. (new): The system of claim 13, wherein said movement data stored in the memory is configured to be downloaded to the computer.

92. (new): The system of claim 91, wherein the portable, self-contained movement measuring device further comprises:

software configured to communicate with the program running on the computer, wherein the program is configured to present the downloaded movement data to the user.

93. (new): The system of claim 92, wherein said downloaded movement data is configured to be analyzed by said user via said program.

94. (new): The system of claim 92, wherein said program is configured to interpret said movement data and produce at least one report.

95. (new): The system of claim 92, wherein said program is configured to interpret said movement data and produce at least one history report.

RESPONSE TO *EX PARTE* REEXAMINATION OFFICE ACTION

Control No.: 90/013,201

Attorney Docket No.: A209779

96. (new): The system of claim 95, wherein said at least one history report includes dates and times of said movement data.

97. (new): The system of claim 92, wherein said program is configured to allow the user to program additional reports and histories with respect to said movement data of said user.

98. (new): The system of claim 91, wherein said movement data is configured to be downloaded to said computer, using the download device, via a wired connection.

99. (new): The system of claim 91, wherein said movement data is configured to be downloaded to said computer, using the download device, via a wireless connection.

Cancel claim 100.

101. (new): The system of claim 85, wherein the output indicator is configured to provide a visual indicator to the user regarding the predetermined threshold being reached.

Cancel claim 102.

103. (new): The system of claim 13, wherein the memory is configured to store the user-defined operational parameters, the user-defined operational parameters comprising a plurality of thresholds respectively corresponding to a plurality of notifications, wherein each time the

movement data reaches one of the plurality of the thresholds, the microprocessor is configured to detect that one of a plurality of user-defined events occurred.

104. (new): The system of claim 103, wherein when the microprocessor detects that one of the user-defined events occurred based on the movement data reaching one of the plurality of the thresholds, the output indicator displays a corresponding one of the notifications indicating that one of the user-defined events has occurred.

Cancel claim 105.

Cancel claim 106.

107. (new): The system of claim 103, wherein the plurality of thresholds are different from each other.

108. (new): The system of claim 103, wherein the plurality of notifications are different visual indicators.

109. (new): The system of claim 108, wherein at least one of the visual indicators includes a blinking indicator.

110. (new): The system of claim 13, wherein said output indicator is configured to signal the occurrence of user-defined events.

111. (new): The system of claim 85, wherein said microprocessor is configured to detect occurrence of the first user-defined event by comparing said movement data to said predetermined threshold.

112. (new): The system of claim 13, wherein said device is configured to be placed on said user's arm to monitor and record said movement data.

113. (new): The system of claim 112, wherein said movement sensor configured to measure movement of said user's arm.

114. (new): The system of claim 13, wherein said movement sensor configured to measure a walking distance.

115. (new): The system of claim 114, wherein said device is configured to be wearable by the user, and said movement sensor is configured to measure said walking distance of said user.

116. (new): The system of claim 13, wherein said microprocessor is configured to store, in said memory, date information associated with the first time stamp information,

RESPONSE TO *EX PARTE* REEXAMINATION OFFICE ACTION

Control No.: 90/013,201

Attorney Docket No.: A209779

wherein said movement sensor is configured to continuously check for said movement,

wherein said output indicator is configured to display information signaling the occurrence of the first user-defined event based on the detection of the first user-defined event and the first time stamp information,

wherein said movement data stored in the memory is configured to be downloaded to the computer,

wherein the device further comprises software configured to communicate with the program which presents the downloaded movement data,

wherein said program is configured to produce at least one report based on said movement data,

wherein the memory is configured to store the user-defined operational parameters, the user-defined operational parameters comprising a plurality of thresholds respectively corresponding to a plurality of notifications, wherein each time the movement data reaches one of the plurality of the thresholds, the microprocessor is configured to detect that one of the user-defined events occurred,

wherein said device is configured to be placed on said user's arm to monitor and record said movement data,

wherein said movement sensor configured to measure movement of said user's arm.

Cancel claim 117.

118. (new): The method of claim 20, further comprising:

storing, in said memory, date information associated with the first time stamp information.

119. (new): The method of claim 20, further comprising:
retrieving said first time stamp information from said real-time clock and associate the retrieved first time stamp information with said first user-defined event.

120. (new): The method of claim 119, further comprising:
retrieving said first time stamp information from said real-time clock based on the detection of the first user-defined event.

Cancel claim 121.

122. (new): The method of claim 20, wherein said storing comprises continuously storing said movement data after battery power is lost from a power source of the portable, self-contained movement measuring device.

123. (new): The method of claim 20, further comprising:
continuously monitoring for said physical movement using a movement sensor of the portable, self-contained movement measuring device.

124. (new): The method of claim 123, wherein said interpreting comprises:

continuously interpreting, based on the user-defined operational parameters, said physical movement data.

125. (new): The method of claim 20, further comprising:
displaying, using an output indicator of the portable, self-contained movement measuring device, information signaling the occurrence of the first user-defined event based on the detection of the user-defined event.

126. (new): The method of claim 125, wherein said output indicator displays said information signaling the occurrence of the first user-defined event based on said first time stamp information.

127. (new): The method of claim 20, further comprising:
displaying, using an output indicator included the portable, self-contained movement measuring device, information signaling the occurrence of the first user-defined event based on the detection of the first user-defined event and the first time stamp information.

128. (new): The method of claim 20, wherein said at least one of the user-defined operational parameters is a predetermined threshold, and said first user-defined event occurs when the movement data reaches the predetermined threshold.

129. (new): The method of claim 128, wherein an output indicator of the portable, self-contained movement measuring device displays information signaling the occurrence of the first user-defined event when the movement data reaches the predetermined threshold.

130. (new): The method of claim 128, further comprising:
storing, in said memory, said first event information indicating that the predetermined threshold is met.

131. (new): The method of claim 130, further comprising:
storing, in said memory, the first time stamp information in association with said first event information.

132. (new): The method of claim 20, further comprising:
indicating a low battery condition, using an output indicator of the portable, self-contained movement measuring device.

133. (new): The method of claim 20, wherein said physical movement data stored in the memory is the interpreted physical movement data, and said stored physical movement data is configured to be downloaded to a computer.

134. (new): The method of claim 133, further comprising:

communicating with external software, wherein the external software is configured to present said interpreted physical movement data to the user.

135. (new): The method of claim 134, wherein said external software is configured to run on a computer.

136. (new): The method of 20, further comprising:
producing a report based on said interpreted physical movement data.

137. (new): The method of 134, further comprising:
producing at least one report based on said interpreted physical movement data using the external software.

138. (new): The method of claim 134, further comprising:
producing at least one history report based on said interpreted physical movement data using the external software.

139. (new): The method of claim 138, wherein said at least one history report includes dates and times of said physical movement data.

140. (new): The method of claim 134, further comprising:

providing additional reports and histories with respect to said interpreted physical movement data, wherein the additional reports and histories are programmed by the user via the external software.

141. (new): The method of claim 133, wherein said physical movement data is configured to be downloaded to said computer via a wired connection.

142. (new): The method of claim 133, wherein said movement data is configured to be downloaded to the computer via a wireless connection.

Cancel claim 143.

144. (new): The method of claim 128, further comprising:
providing, via an output indicator of the portable, self-contained movement measuring device, a visual indicator to the user regarding the predetermined threshold being reached.

Cancel claim 145.

146. (new): The method of claim 20, further comprising:
storing the user-defined operational parameters, the user-defined operational parameters comprising a plurality of thresholds respectively corresponding to a plurality of notifications,

RESPONSE TO *EX PARTE* REEXAMINATION OFFICE ACTION

Control No.: 90/013,201

Attorney Docket No.: A209779

wherein the detecting comprises detecting occurrence of one of a plurality of user-defined events each time the movement data reaches one of the plurality of the thresholds.

147. (new): The method of claim 146, wherein in response to detecting that one of the user-defined events occurred based on the movement data reaching one of the plurality of the thresholds, the method further comprises:

displaying, via an output indicator of the portable, self-contained movement measuring device, a corresponding one of the notifications indicating that one of the user-defined events has occurred.

Cancel claim 148.

Cancel claim 149.

150. (new): The method of claim 146, wherein the plurality of thresholds are different from each other.

151. (new): The method of claim 146, wherein the plurality of notifications are different visual indicators.

152. (new): The method of claim 151, wherein at least one of the visual indicators includes a blinking indicator.

153. (new): The method of claim 20, further comprising:
signaling, using an output indicator included in the portable, self-contained movement
measuring device, the occurrence of user-defined events.

154. (new): The method of claim 128, wherein the detecting comprises comparing said
physical movement data to said predetermined threshold.

155. (new): The method of claim 20, wherein said body part is a user's arm, and said
measuring the data comprises monitoring and recording the physical movement of said user's
arm.

156. (new): The method of claim 155, wherein said measuring the data comprises
measuring the data using a movement sensor of the portable, self-contained movement
measuring device.

157. (new): The method of claim 20, further comprising:
measuring a walking distance based on the interpreted physical movement data.

158. (new): The method of claim 20, further comprising:
storing, in said memory, date information associated with the first time stamp
information;

RESPONSE TO *EX PARTE* REEXAMINATION OFFICE ACTION

Control No.: 90/013,201

Attorney Docket No.: A209779

continuously monitoring for said physical movement using a movement sensor of the portable, self-contained movement measuring device;

displaying, using an output indicator included the portable, self-contained movement measuring device, information signaling the occurrence of the first user-defined event based on the detection of the first user-defined event and the first time stamp information,

wherein said physical movement data stored in the memory is the interpreted physical movement data, and said stored physical movement data is configured to be downloaded to a computer;

communicating with external software configured to run on the computer and present said interpreted physical movement data to the user;

producing a report based on said interpreted physical movement data using the external software; and

storing the user-defined operational parameters, the user-defined operational parameters comprising a plurality of thresholds respectively corresponding to a plurality of notifications, wherein the detecting comprises detecting occurrence of one of a plurality of user-defined events each time the movement data reaches one of the plurality of the thresholds,

wherein said body part is a user's arm, and said measuring the data comprises monitoring and recording the physical movement of said user's arm.

159. (new): The device of claim 1, wherein the user-defined operational parameters comprise a first predetermined threshold and a second predetermined threshold different from the first predetermined threshold,

RESPONSE TO *EX PARTE* REEXAMINATION OFFICE ACTION

Control No.: 90/013,201

Attorney Docket No.: A209779

wherein the first user-defined event occurs when the movement data reaches the first predetermined threshold and a second user-defined event occurs when the movement data reaches the second predetermined threshold,

wherein said microprocessor is configured to interpret said movement data to determine whether the movement data reaches the first predetermined threshold and whether the movement data reaches the second predetermined threshold.

160. (new): The device of claim 159, wherein the output indicator is configured to display first information indicating occurrence of the first user-defined event when it is determined that the first predetermined threshold is met, and configured to display second information indicating occurrence of the second user-defined event when it is determined that the second predetermined threshold is met.

161. (new): The device of claim 160, wherein the displayed first information is different from the displayed second information.

162. (new): The device of claim 1, wherein the first user-defined event is a movement exceeding a user-defined angle limit and the first time stamp information reflects a time at which the movement exceeded the user-defined angle limit.

163. (new): The device of claim 1, wherein said first user-defined event is a predetermined type of movement.

164. (new): The device of claim 163, wherein the predetermined type of movement is movement exceeding a predetermined angle limit.

165. (new): The device of claim 163, wherein the predetermined type of movement is movement exceeding a predefined speed.

166. (new): The device of claim 163, wherein the predetermined type of movement is no movement for a predetermined amount of time.

167. (new): The device of claim 163, wherein the predetermined type of movement is a maximum number of incorrect movements allowed in a predetermined time period.

168. (new): The device of claim 1, wherein said microprocessor is configured to detect a second event based on at least one of the user-defined operational parameters and the movement data, and said microprocessor is configured to store, in said memory, second event information related to the detected second event along with second time stamp information reflecting a time at which the second event occurred.

169. (new): The device of claim 168, wherein said second event is a predetermined type of movement.

170. (new): The device of claim 169, wherein the predetermined type of movement is movement exceeding a predetermined angle limit.

171. (new): The device of claim 169, wherein the predetermined type of movement is movement exceeding a predefined speed.

172. (new): The device of claim 169, wherein the predetermined type of movement is no movement for a predetermined amount of time.

173. (new): The device of claim 169, wherein the predetermined type of movement is a maximum number of incorrect movements allowed in a predetermined time period.

174. (new): The system of claim 13, wherein the user-defined operational parameters comprise a first predetermined threshold and a second predetermined threshold different from the first predetermined threshold,

wherein the first user-defined event occurs when the movement data reaches the first predetermined threshold and a second user-defined event occurs when the movement data reaches the second predetermined threshold,

wherein said microprocessor is configured to interpret said movement data to determine whether the movement data reaches the first predetermined threshold and whether the movement data reaches the second predetermined threshold.

RESPONSE TO *EX PARTE* REEXAMINATION OFFICE ACTION

Control No.: 90/013,201

Attorney Docket No.: A209779

175. (new): The system of claim 174, wherein the output indicator is configured to display first information indicating occurrence of the first user-defined event when it is determined that the first predetermined threshold is met, and configured to display second information indicating occurrence of the second user-defined event when it is determined that the second predetermined threshold is met.

176. (new): The system of claim 175, wherein the displayed first information is different from the displayed second information.

177. (new): The system of claim 13, wherein the first user-defined event is a movement exceeding a user-defined angle limit and the first time stamp information reflects a time at which the movement exceeded the user-defined angle limit.

178. (new): The system of claim 13, wherein said first user-defined event is a predetermined type of movement.

179. (new): The system of claim 178, wherein the predetermined type of movement is movement exceeding a predetermined angle limit.

180. (new): The system of claim 178, wherein the predetermined type of movement is movement exceeding a predefined speed.

RESPONSE TO *EX PARTE* REEXAMINATION OFFICE ACTION

Control No.: 90/013,201

Attorney Docket No.: A209779

181. (new): The system of claim 178, wherein the predetermined type of movement is no movement for a predetermined amount of time.

182. (new): The system of claim 178, wherein the predetermined type of movement is a maximum number of incorrect movements allowed in a predetermined time period.

183. (new): The system of claim 13, wherein said microprocessor is configured to detect a second event based on at least one of the user-defined operational parameters and the movement data, and said microprocessor is configured to store, in said memory, second event information related to the detected second event along with second time stamp information reflecting a time at which the second event occurred.

184. (new): The system of claim 183, wherein said second event is a predetermined type of movement.

185. (new): The system of claim 184, wherein the predetermined type of movement is movement exceeding a predetermined angle limit.

186. (new): The system of claim 184, wherein the predetermined type of movement is movement exceeding a predefined speed.

187. (new): The system of claim 184, wherein the predetermined type of movement is no movement for a predetermined amount of time.

188. (new): The system of claim 184, wherein the predetermined type of movement is a maximum number of incorrect movements allowed in a predetermined time period.

189. (new): The system of claim 13, wherein said movement sensor comprises at least one accelerometer.

190. (new): The method of claim 20, wherein the user-defined operational parameters comprise a first predetermined threshold and a second predetermined threshold different from the first predetermined threshold,

wherein the first user-defined event occurs when the movement data reaches the first predetermined threshold and a second user-defined event occurs when the movement data reaches the second predetermined threshold,

wherein said interpreting comprises interpreting said movement data to determine whether the movement data reaches the first predetermined threshold and whether the movement data reaches the second predetermined threshold.

191. (new): The method of claim 190, further comprising:
displaying, using an output indicator included in the portable, self-contained movement measuring device, first information indicating occurrence of the first user-defined event when it

is determined that the first predetermined threshold is met and second information indicating occurrence of the second user-defined event when it is determined that the second predetermined threshold is met.

192. (new): The method of claim 191, wherein the displayed first information is different from the displayed second information.

193. (new): The method of claim 20, wherein the first user-defined event is a movement exceeding a user-defined angle limit and the first time stamp information reflects a time at which the movement exceeded the user-defined angle limit.

194. (new): The method of claim 20, wherein said first user-defined event is a predetermined type of movement.

195. (new): The method of claim 194, wherein the predetermined type of movement is movement exceeding a predetermined angle limit.

196. (new): The method of claim 194, wherein the predetermined type of movement is movement exceeding a predefined speed.

197. (new): The method of claim 194, wherein the predetermined type of movement is no movement for a predetermined amount of time.

198. (new): The method of claim 194, wherein the predetermined type of movement is a maximum number of incorrect movements allowed in a predetermined time period.

199. (new): The method of claim 20, further comprising:
detecting, using the microprocessor, a second event based on at least one of the user-defined operational parameters and the movement data; and
storing, in said memory, second event information related to the detected second event along with second time stamp information reflecting a time at which the second event occurred.

200. (new): The method of claim 199, wherein said second event is a predetermined type of movement.

201. (new): The method of claim 200, wherein the predetermined type of movement is movement exceeding a predetermined angle limit.

202. (new): The method of claim 200, wherein the predetermined type of movement is movement exceeding a predefined speed.

203. (new): The method of claim 200, wherein the predetermined type of movement is no movement for a predetermined amount of time.

RESPONSE TO *EX PARTE* REEXAMINATION OFFICE ACTION
Control No.: 90/013,201
Attorney Docket No.: A209779

204. (new): The method of claim 200, wherein the predetermined type of movement is a maximum number of incorrect movements allowed in a predetermined time period.

RESPONSE TO *EX PARTE* REEXAMINATION OFFICE ACTION

Control No.: 90/013,201

Attorney Docket No.: A209779

II. STATUS OF THE CLAIMS AND EXEMPLARY SUPPORT FOR CLAIM AMENDMENTS

Claim No.	Status	Support in Specification
1	Pending	col. 5, line 59 to col. 6, line 9
2	Pending	NA
3	Pending	NA
4	Pending	NA
5	Pending	NA
6	Pending	NA
7	Pending	NA
8	Pending	NA
9	Pending	NA
10	Pending	NA
11	Pending	NA
12	Pending	NA
13	Pending	col. 5, line 59 to col. 6, line 9
14	Pending	NA
15	Pending	NA
16	Pending	NA
17	Pending	NA
18	Pending	NA
19	Pending	NA
20	Pending	col. 5, line 59 to col. 6, line 9
21	Pending	NA
22	Pending	NA
23	Pending	NA
24	Pending	NA
25	Pending	NA
26	Pending	NA
27	Pending	NA
28	Pending	NA
29	Pending	NA
30	Canceled	NA
31	New	col. 6, lines 5-9
32	New	col. 5, line 44; col. 6, line 9
33	New	col. 5, line 44; col. 6, line 9
34	Canceled	NA
35	New	col. 5, lines 47-51
36	New	col. 5, lines 40-41
37	New	col. 6, lines 16-40

RESPONSE TO *EX PARTE* REEXAMINATION OFFICE ACTION

Control No.: 90/013,201

Attorney Docket No.: A209779

38	New	col. 4, lines 5-14 and col. 6, lines 6-15
39	New	col. 4, lines 5-14 and col. 6, lines 6-15
40	New	col. 4, lines 5-14 and col. 6, lines 6-15
41	New	col. 5, line 59 to col. 6, line 9 and col. 7, lines 6-30
42	New	col. 5, line 58 to col. 6, line 3 and col. 6, lines 41-43
43	New	col. 6, lines 6-9
44	New	col. 6, lines 6-9 and col. 6, lines 19-21
45	New	col. 6, lines 27-39
46	New	col. 5, lines 25-27
47	New	col. 8, lines 31-55
48	New	col. 8, lines 31-55
49	New	col. 8, lines 31-55
50	New	col. 8, lines 40-55
51	New	col. 8, lines 40-55
52	New	col. 8, lines 40-55
53	New	col. 8, lines 40-55
54	New	col. 8, lines 40-55
55	New	col. 8, lines 30-55
56	New	col. 8, lines 30-55
57	Canceled	NA
58	New	col. 4, lines 9-14
59	Canceled	NA
60	New	col. 5, line 58 to col. 6, line 15 and col. 7, lines 6-30
61	New	col. 5, line 58 to col. 6, line 15 and col. 7, lines 6-30
62	Canceled	NA
63	Canceled	NA
64	New	col. 5, line 58 to col. 6, line 15
65	New	col. 4, lines 5-14
66	New	col. 4, lines 5-14
67	Canceled	NA
68	New	col. 5, line 58 to col. 6, line 15 and col. 7, lines 6-30
69	New	col. 3, lines 59-62
70	New	col. 3, lines 59-62
71	New	col. 3, lines 45-47
72	New	col. 3, lines 45-47
73	New	col. 3, lines 59-62, col. 4, lines 5-14, col. 5, lines 40-41, col. 5, line 58 to col. 6, line 15, col. 7, lines 6-30, and col. 8, lines 30-55
74	Canceled	NA
75	New	col. 6, lines 5-9
76	New	col. 5, line 44; col. 6, line 9
77	New	col. 5, line 44; col. 6, line 9
78	Canceled	NA

RESPONSE TO *EX PARTE* REEXAMINATION OFFICE ACTION

Control No.: 90/013,201

Attorney Docket No.: A209779

79	New	col. 5, lines 47-51
80	New	col. 5, lines 40-41
81	New	col. 6, lines 16-40
82	New	col. 4, lines 5-14 and col. 6, lines 6-15
83	New	col. 4, lines 5-14 and col. 6, lines 6-15
84	New	col. 4, lines 5-14 and col. 6, lines 6-15
85	New	col. 5, line 59 to col. 6, line 9 and col. 7, lines 6-30
86	New	col. 5, line 58 to col. 6, line 3 and col. 6, lines 41-43
87	New	col. 6, lines 6-9
88	New	col. 6, lines 6-9 and col. 6, lines 19-21
89	New	col. 6, lines 27-39
90	New	col. 5, lines 25-27
91	New	col. 8, line 31-55
92	New	col. 8, line 31-55
93	New	col. 8, line 40-55
94	New	col. 8, line 40-55
95	New	col. 8, line 40-55
96	New	col. 8, line 40-55
97	New	col. 8, line 40-55
98	New	col. 8, line 30-45
99	New	col. 8, lines 30-55
100	Canceled	NA
101	New	col. 4, lines 9-14
102	Canceled	NA
103	New	col. 5, line 58 to col. 6, line 15 and col. 7, lines 6-30
104	New	col. 5, line 58 to col. 6, line 15 and col. 7, lines 6-30
105	Canceled	NA
106	Canceled	NA
107	New	col. 5, line 58 to col. 6, line 15
108	New	col. 4, lines 5-14
109	New	col. 4, lines 5-14
110	New	col. 4, lines 3-14
111	New	col. 5, line 58 to col. 6, line 15 and col. 7, lines 6-30
112	New	col. 3, lines 59-62
113	New	col. 3, lines 59-62
114	New	col. 3, lines 45-47
115	New	col. 3, lines 45-47
116	New	col. 3, lines 59-62, col. 4, lines 5-14, col. 5, lines 40-41, col. 5, line 58 to col. 6, line 15, col. 7, lines 6-30, and col. 8, lines 30-55
117	Canceled	NA
118	New	col. 6, lines 5-9
119	New	col. 5, line 44; col. 6, line 9

RESPONSE TO *EX PARTE* REEXAMINATION OFFICE ACTION

Control No.: 90/013,201

Attorney Docket No.: A209779

120	New	col. 5, line 44; col. 6, line 9
121	Canceled	NA
122	New	col. 5, lines 47-51
123	New	col. 5, lines 40-41
124	New	col. 6, lines 16-40
125	New	col. 4, lines 5-14 and col. 6, lines 6-15
126	New	col. 4, lines 5-14 and col. 6, lines 6-15
127	New	col. 4, lines 5-14 and col. 6, lines 6-15
128	New	col. 5, line 59 to col. 6, line 9 and col. 7, lines 6-30
129	New	col. 5, line 58 to col. 6, line 3 and col. 6, lines 41-43
130	New	col. 6, lines 6-9
131	New	col. 6, lines 6-9 and col. 6, lines 19-21
132	New	col. 6, lines 27-39
133	New	col. 8, line 31-55
134	New	col. 8, line 31-55
135	New	col. 8, line 31-55
136	New	col. 8, line 40-55
137	New	col. 8, line 40-55
138	New	col. 8, line 40-55
139	New	col. 8, line 40-55
140	New	col. 8, line 40-55
141	New	col. 8, line 30-45
142	New	col. 8, line 30-45
143	Canceled	NA
144	New	col. 4, lines 9-14
145	Canceled	NA
146	New	col. 5, line 58 to col. 6, line 15 and col. 7, lines 6-30
147	New	col. 5, line 58 to col. 6, line 15 and col. 7, lines 6-30
148	Canceled	NA
149	Canceled	NA
150	New	col. 5, line 58 to col. 6, line 15
151	New	col. 4, lines 5-14
152	New	col. 4, lines 5-14
153	New	col. 4, lines 3-14
154	New	col. 5, line 58 to col. 6, line 15 and col. 7, lines 6-30
155	New	col. 3, lines 59-62
156	New	col. 4, lines 38-45
157	New	col. 3, lines 45-47
158	New	col. 3, lines 59-62, col. 4, lines 5-14, col. 5, lines 40-41, col. 5, line 58 to col. 6, line 15, col. 7, lines 6-30, and col. 8, lines 30-55
159	New	col. 5, line 58 to col. 6, line 40 and col. 7, lines 6-30
160	New	col. 4, lines 5-14

RESPONSE TO *EX PARTE* REEXAMINATION OFFICE ACTION

Control No.: 90/013,201

Attorney Docket No.: A209779

161	New	col. 4, lines 5-14
162	New	col. 5, line 59 to col. 6, line 15
163	New	col. 6, lines 16-40 and col. 10, lines 50-54
164	New	col. 6, lines 19-26
165	New	col. 6, lines 19-40
166	New	col. 6, lines 19-40
167	New	paragraph bridging cols. 7-8
168	New	col. 5, line 59 to col. 6, line 9, and col. 7, lines 6-30
169	New	col. 6, lines 16-40 and col. 10, lines 50-54
170	New	col. 6, lines 19-26
171	New	col. 6, lines 19-40
172	New	col. 6, lines 19-40
173	New	paragraph bridging cols. 7-8
174	New	col. 5, line 58 to col. 6, line 40 and col. 7, lines 6-30
175	New	col. 4, lines 5-14
176	New	col. 4, lines 5-14
177	New	col. 5, line 59 to col. 6, line 15
178	New	col. 6, lines 16-40 and col. 10, lines 50-54
179	New	col. 6, lines 19-26
180	New	col. 6, lines 19-40
181	New	col. 6, lines 19-40
182	New	paragraph bridging cols. 7-8
183	New	col. 5, line 59 to col. 6, line 9, and col. 7, lines 6-30
184	New	col. 6, lines 16-40 and col. 10, lines 50-54
185	New	col. 6, lines 19-26
186	New	col. 6, lines 19-40
187	New	col. 6, lines 19-40
188	New	paragraph bridging cols. 7-8
189	New	col. 4, lines 38-45
190	New	col. 5, line 58 to col. 6, line 40 and col. 7, lines 6-30
191	New	col. 4, lines 5-14
192	New	col. 4, lines 5-14
193	New	col. 5, line 59 to col. 6, line 15
194	New	col. 6, lines 16-40 and col. 10, lines 50-54
195	New	col. 6, lines 19-26
196	New	col. 6, lines 19-40
197	New	col. 6, lines 19-40
198	New	paragraph bridging cols. 7-8
199	New	col. 5, line 59 to col. 6, line 9, and col. 7, lines 6-30
200	New	col. 6, lines 16-40 and col. 10, lines 50-54
201	New	col. 6, lines 19-26
202	New	col. 6, lines 19-40

RESPONSE TO *EX PARTE* REEXAMINATION OFFICE ACTION

Control No.: 90/013,201

Attorney Docket No.: A209779

203	New	col. 6, lines 19-40
204	New	paragraph bridging cols. 7-8

III. REMARKS

Claims 1, 13, 20, 21, and 30-158 are subject to reexamination. All the reexamined claims are rejected.

By this Amendment, previously added claims 30, 34, 57, 59, 62, 63, 67, 74, 78, 100, 102, 105, 106, 117, 121, 143, 145, 148, and 149 have been canceled without prejudice or disclaimer.

New claims 159-204 have been added.

Accordingly, claims 1-29, 31-33, 35-56, 58, 60, 61, 64-66, 68-73, 75-77, 79-99, 101, 103, 104, 107-116, 118-120, 122-142, 144, 146, 147, and 150-204 are all the claims pending in the proceeding.

Claims 1, 13, and 20 are the independent claims.

Summary or claim amendments and response

As an initial matter, Patent Owner's (PO's) representatives would again like to thank Examiners Danton De Mille along with Eileen Lillis and Robert Fetsuga for the courtesies extended during the personal interview conducted on September 3, 2014 (*see* Examiner's Interview Summary dated September 12, 2014 and Statement of Substance of Interview filed October 3, 2014).

During the interview, differences between the claimed invention and the cited references (primarily Flentov, Vock, and Burdea) were highlighted by the PO's representatives.

With respect to the "time stamp" feature set forth in claims 30, 32, and 33, the Examiners indicated that the claims, as currently drafted, may not reflect the feature as intended to be interpreted by the PO. Some proposed clarifying amendments were discussed in this regard.

RESPONSE TO *EX PARTE* REEXAMINATION OFFICE ACTION

Control No.: 90/013,201

Attorney Docket No.: A209779

There was a similar discussion regarding claims 60, 61, and 67 relating to the storage of a plurality of thresholds corresponding to a plurality of notifications, and how the threshold relates to a user-defined event in the claims. The Examiners thought that the claims broadly read on a certain interpretation of the cited reference(s). Again, some possibly clarifying amendments were generally discussed that would preclude the claims from being read on the cited reference(s).

The Examiners agreed that if a formal response is filed with clarifying amendments along the lines discussed during the interview, the Examiners would reconsider their current position regarding the combination of Flentov/Vock with Burdea.

Accordingly, by way of this Amendment, independent claims 1, 13, and 20 have been amended to recite, in some variation, that the microprocessor detects a first user-defined event based on at least one of the user-defined operational parameters and the movement data, and stores first event information related to the detected first user-defined event along with first time stamp information reflecting a time at which the first user-defined event occurred.

For example, in a non-limiting embodiment of the claimed invention, a user can define certain operational parameters such as angle limits in the device 12, and the microprocessor 32 detects whether the user's movement has passed the given angle limit(s) (an example of detecting a user-defined event) based on the given angle and the movement data received from the movement sensor 30 (patent specification, col. 5, line 59 to col. 6, line 9). The microprocessor 32 obtains time stamp information from a clock 46 and stores the obtained time stamp information along with information about the angle limit that was exceeded into memory 50. *Id.*

As discussed below in further detail, the cited references do not teach or suggest the features set forth in the amended independent claims.

Further, additional new claims have been added (see claims 159-204) which are necessarily patentable *at least* by virtue of their dependency. Moreover, these claims recite features that are in and of themselves novel and non-obvious.

For example, claims 159, 174, and 190 specify that the user-defined operational parameters comprise a first predetermined threshold and a second predetermined threshold different from the first predetermined threshold, and that the first user-defined event occurs when the movement data reaches the first predetermined threshold and a second user-defined event occurs when the movement data reaches the second predetermined threshold. That is, in the claimed invention, at least two different events can be detected based on different predetermined thresholds. For instance, in the non-limiting embodiment(s), a plurality of angular levels at which notices will be generated are stored in the device 12, and this way, the user may choose the angular positions at which the user wants to be warned (i.e., when the angular levels are exceeded) (e.g., patent specification, col. 5, line 58 to col. 6, line 40 and col. 7, lines 6-30).

Similarly, claims 162, 176, and 193 recite in some variation that the first user-defined event is a movement exceeding a user-defined angle limit and the first time stamp information reflects a time at which the movement exceeded the user-defined angle limit.

Further, new claims 163-167 and 169-173 specify the first and second events as predetermined types of movements (e.g., movement exceeding a predetermined angle limit, movement exceeding a predefined speed, no movement for a predetermined amount of time, or a maximum number of incorrect movements allowed in a predetermined time period).

These features are not disclosed or suggested by the cited references.

Accordingly, as discussed in further detail below, the instant Amendment places the claims in condition for immediate allowance. Consequently, PO respectfully requests the Examiner to issue a Notice of Intent to Issue *Ex Parte* Reexamination Certificate responsive to this Amendment.

Claim Rejections - 35 USC § 112

Claims 93, 123, 149 are rejected under 35 U.S.C. 112(b) or 35 U.S.C. 112 (pre-AIA), second paragraph, as allegedly being indefinite.

In view of the clarifying amendments to claims 93 and 123 being made herein, withdrawal of the rejections thereto is respectfully requested.

Since claim 149 has been canceled, the rejection thereto is rendered moot.

Claim Rejections - 35 USC §102

Claims 1 and 20 are rejected under pre-AIA 35 U.S.C. 102(b) as allegedly being anticipated by Flentov et al.

Claims 1 and 20 are rejected under 35 U.S.C. 102(e) as allegedly being anticipated by Gaudet et al.

Claims 1 and 20 are rejected under 35 U.S.C. 102(e) as allegedly being anticipated by Vock et al.

As discussed above, claims 1 and 20 have been amended to recite, in some variation, that the microprocessor detects a first user-defined event based on at least one of the user-defined

operational parameters and the movement data, and stores first event information related to the detected first user-defined event along with first time stamp information reflecting a time at which the first user-defined event occurred.

Flentov, Gaudet, and Vock do not disclose these features in as complete detail as set forth in the claims.

Accordingly, these rejections are rendered moot.

Claim Rejections - 35 USC §103

Claims 1, 13, 20, 21, and 30-158 are rejected under pre-AIA 35 U.S.C. 103(a) as allegedly being unpatentable over Flentov et al. in view of Burdea et al.

Claims 1, 13, 20, 21, 30-40, 45-56, 69-72, 74-84, 89-99, 109, 112-115, 117-127, 132-142, and 155-157 are rejected under pre-AIA 35 U.S.C. 103(a) as allegedly being unpatentable over Gaudet et al. in view of Burdea et al.

Claims 1, 13, 20, 21, and 30-158 are rejected under pre-AIA 35 U.S.C. 103(a) as allegedly being unpatentable over Vock et al. in view of Burdea et al.

For *at least* the following reasons, PO respectfully traverses these rejections.

As discussed above, claims 1, 13, and 20 have been amended to recite, in some variation, that the microprocessor detects a first user-defined event based on at least one of the user-defined operational parameters and the movement data, and stores first event information related to the detected first user-defined event along with first time stamp information reflecting a time at which the first user-defined event occurred.

These claim amendments have been made by the PO in light of the Examiners' suggestions during the aforementioned interview.

In particular, based on the Examiner's comments in the Office Action and the explanation provided by the Examiner during the personal interview, it is understood that the Examiner is primarily relying on the air time or loft time in Flentov and Vock for allegedly teaching the claimed user-defined event. It is acknowledged that Flentov and Vock do not teach or suggest the claimed time stamp information (e.g., see Office Action, page 15 and Examiner's Interview Summary dated September 12, 2014, page 3). However, Burdea is relied upon for allegedly curing these deficient teachings of Flentov and Vock. *Id.*

PO respectfully submits that even if the teachings of Flentov/Vock are combined with Burdea, the proposed combination of the references still does not teach or suggest the features set forth in independent claims 1, 13, and 20, which were amended along the lines discussed during the personal interview.

For example, in the claimed invention, the microprocessor detects a first user-defined event based on at least one of the user-defined operational parameters and the movement data and stores first event information related to the detected first user-defined event along with first time stamp information reflecting a time at which the first user-defined event occurred.

Assuming *arguendo* that the air time or loft time in Flentov/Vock correspond to the claimed user-defined event, then the proposed modification with Burdea would result in the user's air times or loft times for their entire skiing session to be stored in a database at the end of the session along with a time stamp indicating the time at which the database was updated.

RESPONSE TO *EX PARTE* REEXAMINATION OFFICE ACTION

Control No.: 90/013,201

Attorney Docket No.: A209779

As such, the stored time stamp in the proposed modification would not result in the storing of the claimed first time stamp information reflecting a time at which the first user-defined event (air time or loft time) occurred, as required by independent claims 1, 13, and 20. Rather, if Burdea's teachings are incorporated into Flentov/Vock or *vice versa*, then in the modified system, the time stamp associated with the stored air/loft time data would reflect the time at which the air/loft time data are stored in the database - not the time at which the air/loft time occurred.

In further detail, Burdea discloses that "[p]atient data can be stored in database 114 for statistical purposes. Database 114 can include a time stamp for providing a time history of updates of the patient information" (Burdea, col. 6, lines 30-33). That is, the time stamp described in Burdea is related to the update time at which the patient data (allegedly interchangeable with the air/loft time data in Flentov/Vock) is updated at the database 114.

On the other hand, in the claimed invention, the first time stamp information reflects the time at which the first user-defined vent occurred.

Gaudet does not cure the above-noted deficient teachings of Flentov, Vock, and Burdea.

Accordingly, PO respectfully submits that claims 1, 13, and 20 are patentable over the asserted combinations of Flentov, Vock, or Gaudet with Burdea.

PO respectfully submits that the remaining claims are patentable *at least* by virtue of their dependency.

Moreover, PO respectfully submits that claims 41, 85, and 128 are patentable for reasons in addition to their dependency, as discussed below.

Claims 41, 85, and 128

Claims 41, 85, and 128, in view of clarifying amendments being made herein, recite that at least one of the user-defined operational parameters is a predetermined threshold, and said first user-defined event occurs when the movement data reaches the predetermined threshold¹.

Flentov and/or Vock appear to be generally relied upon in the Office Action to teach a threshold (e.g., see pages 21-22 and 49 of Office Action).

For example, at pages 21-22 of the Office Action, it is asserted that Flentov discloses the threshold feature because allegedly, "[w]hen the user starts and stops the collection of movement data, the user has set the threshold amount of movement data to collect to determine the total number of jumps during that period of time. The peak "air" time and the peak speed are additional thresholds that are saved in memory..."

However, it is unclear how the user's starting and stopping of the movement data collection corresponds to a predetermined threshold stored in memory. Also, the peak "air" time and peak speed in Flentov are naturally not stored in advance since they are only obtained after analyzing the data collected from the sensor.

To expedite prosecution, claim 41 has been amended to recite that at least one of the user-defined operational parameters is a *predetermined* threshold, and that the user-defined event occurs when the movement data reaches the *predetermined* threshold, as noted above.

The start and stop signals or the peak air time/peak speed are not compatible with the plain and ordinary meaning of a predetermined threshold, as claimed.

¹ Supported by *at least* col. 5, lines 59-66 and col. 7, lines 5-43 of U.S. Patent No. 6,059,576.

RESPONSE TO *EX PARTE* REEXAMINATION OFFICE ACTION

Control No.: 90/013,201

Attorney Docket No.: A209779

Moreover, the cited references do not and cannot teach or suggest that the air time or loft time (alleged user-defined events) occur when the movement data reaches the start/stop signals or the peak air time/peak speed (alleged thresholds).

Therefore, PO respectfully submits that claims 41, 85, and 128 are patentable over the cited references alone, or in combination.

New claims

It is noted that new claims 30-158 were proposed as new claims in the Request for *Ex Parte* Reexamination filed April 4, 2014.

By way of this Amendment, some of these claims have been canceled without prejudice or disclaimer while other claims have been revised to maintain consistency with the amendments to the independent claims. Support for the revised new claims is shown in Section II above.

PO submits that the above statement complies with MPEP 2250, Section IV(E), which states that "[a]lthough the presentation of the amended claim does not contain any indication of what is changed from a previous version of the [new] claim, patent owner must point out what is changed, in the "Remarks" portion of the amendment."

It is respectfully submitted that new claims 159-204 are patentable *at least* by virtue of their dependency. Moreover, the cited references do not teach or suggest the features set forth therein.

For example, the cited references do not teach or suggest that:

the user-defined operational parameters comprise a first predetermined threshold and a second predetermined threshold, wherein the first user-defined event occurs when the movement data reaches the first predetermined threshold and a second

RESPONSE TO *EX PARTE* REEXAMINATION OFFICE ACTION

Control No.: 90/013,201

Attorney Docket No.: A209779

user-defined event occurs when the movement data reaches the second predetermined threshold, wherein said microprocessor is configured to interpret said movement data to determine whether the movement data reaches the first predetermined threshold and whether the movement data reaches the second predetermined threshold (claims 159, 174, and 190);

the output indicator is configured to display first information indicating occurrence of the first user-defined event when it is determined that the first predetermined threshold is met, and configured to display second information indicating occurrence of the second user-defined event when it is determined that the second predetermined threshold is met (claims 161, 176, and 192);

the user-defined event is a movement exceeding a user-defined angle limit and the first time stamp information reflects a time at which the movement exceeded the user-defined angle limit (claims 162, 177, and 193);

said first user-defined event is a predetermined type of movement (claims 163, 178, and 194);

the predetermined type of movement is movement exceeding a predetermined angle limit (claims 164, 179, and 195);

the predetermined type of movement is movement exceeding a predefined speed (claims 165, 180, and 196);

the predetermined type of movement is no movement for a predetermined amount of time (claims 166, 181, and 197);

the predetermined type of movement is a maximum number of incorrect movements allowed in a predetermined time period (claims 167, 182, and 198);
and

said microprocessor is configured to detect a second event based on at least one of the user-defined operational parameters and the movement data, and said microprocessor is configured to store, in said memory, second event information related to the detected second event along with second time stamp information reflecting a time at which the second event occurred (claims 168, 183, and 199).

Take, for example, claims 168, 183, and 199.

As noted above, these claims recite in some variation that said microprocessor is configured to detect a second event based on at least one of the user-defined operational parameters and the movement data, and said microprocessor is configured to store, in said

RESPONSE TO *EX PARTE* REEXAMINATION OFFICE ACTION

Control No.: 90/013,201

Attorney Docket No.: A209779

memory, second event information related to the detected second event along with second time stamp information reflecting a time at which the second event occurred.

That is, in the claimed invention, in addition to storing a detected first user-defined event along with first time stamp information reflecting a time at which the first user-defined event occurred, the microprocessor additionally detects a second event based on the movement data, and stores, in said memory, second time stamp information in association with said second event. The second time stamp information reflects a time at which the second event occurred.

So *at least* two different events are detected and corresponding time stamp information reflecting the time at which these events occurred is stored in the claimed invention (*also see* claims 159, 174, and 190).

Flentov, Gaudet, and Vock do not disclose or even suggest storing time stamp information in association with the time at which the alleged events in those references occur (e.g., air time in Flentov). As discussed above, Burdea does not cure these deficient teachings of Flentov, Gaudet, and Vock because the time stamp in Burdea reflects the time at which the patient data is updated in the database, not the time at which an event detected based on movement data occurred.

Therefore, it is respectfully submitted that claims 168, 183, and 199 are patentable over the cited references, alone or in combination.

Moreover, it is noted that in the claimed invention, the first user-defined event and second event could be predetermined types of movement (e.g., claims 163 and 169). The predetermined types of movement could be movement exceeding a predetermined angle limit

RESPONSE TO *EX PARTE* REEXAMINATION OFFICE ACTION

Control No.: 90/013,201

Attorney Docket No.: A209779

(e.g., claims 164 and 170), or movement exceeding a predefined speed (e.g., claims 165 and 171), no movement for a predetermined amount of time (e.g., claims 166 and 172), and a maximum number of incorrect movements allowed in a predetermined time period (e.g., claims 167 and 173).

There is no disclosure or suggestion in the cited references regarding detecting such predetermined types of movement, let alone detecting such predetermined types of movement and associating with the detected events time stamp information reflecting a time at which the subject events occurred, in as complete detail as set forth in the claims.

Conclusion

In view of the above, reconsideration and issuance of a Notice of Intent to Issue *Ex Parte* Reexamination Certificate in this proceeding are now believed to be in order, and such actions are hereby solicited. If any points remain in issue which the Examiner feels may be best resolved through a personal or telephone interview, the Examiner is kindly requested to contact the undersigned at the telephone number listed below.

RESPONSE TO *EX PARTE* REEXAMINATION OFFICE ACTION
Control No.: 90/013,201
Attorney Docket No.: A209779

The USPTO is directed and authorized to charge all required fees, except for the Issue Fee and the Publication Fee, to Deposit Account No. 19-4880. Please also credit any overpayments to said Deposit Account.

Respectfully submitted,

/Abdul-Quadeer Ahmed/

SUGHRUE MION, PLLC
Telephone: 202.293.7060
Facsimile: 202.293.7860

WASHINGTON OFFICE

23373

CUSTOMER NUMBER

Date: October 14, 2014

Quadeer A. Ahmed
Registration No. 60,835

Electronic Patent Application Fee Transmittal

Application Number:	90013201			
Filing Date:	04-Apr-2014			
Title of Invention:	TRAINING AND SAFETY DEVICE, SYSTEM AND METHOD TO AID IN PROPER MOVEMENT DURING PHYSICAL ACTIVITY			
First Named Inventor/Applicant Name:	6059576			
Filer:	Quadeer A. Ahmed/Shanele Jones			
Attorney Docket Number:	A209779			
Filed as Large Entity				
ex parte reexam Filing Fees				
Description	Fee Code	Quantity	Amount	Sub-Total in USD(\$)
Basic Filing:				
Pages:				
Claims:				
Reexamination claims in excess of 20	1822	27	80	2160
Miscellaneous-Filing:				
Petition:				
Patent-Appeals-and-Interference:				
Post-Allowance-and-Post-Issuance:				
Extension-of-Time:				

Description	Fee Code	Quantity	Amount	Sub-Total in USD(\$)
Miscellaneous:				
Total in USD (\$)				2160

Electronic Acknowledgement Receipt

EFS ID:	20412812
Application Number:	90013201
International Application Number:	
Confirmation Number:	9930
Title of Invention:	TRAINING AND SAFETY DEVICE, SYSTEM AND METHOD TO AID IN PROPER MOVEMENT DURING PHYSICAL ACTIVITY
First Named Inventor/Applicant Name:	6059576
Customer Number:	23373
Filer:	Quadeer A. Ahmed/Shanele Jones
Filer Authorized By:	Quadeer A. Ahmed
Attorney Docket Number:	A209779
Receipt Date:	14-OCT-2014
Filing Date:	04-APR-2014
Time Stamp:	16:54:05
Application Type:	Reexam (Patent Owner)

Payment information:

Submitted with Payment	yes
Payment Type	Deposit Account
Payment was successfully received in RAM	\$2160
RAM confirmation Number	3891
Deposit Account	194880
Authorized User	

The Director of the USPTO is hereby authorized to charge indicated fees and credit any overpayment as follows:

Charge any Additional Fees required under 37 C.F.R. Section 1.16 (National application filing, search, and examination fees)

Charge any Additional Fees required under 37 C.F.R. Section 1.17 (Patent application and reexamination processing fees)

Charge any Additional Fees required under 37 C.F.R. Section 1.19 (Document supply fees)

Charge any Additional Fees required under 37 C.F.R. Section 1.21 (Miscellaneous fees and charges)

File Listing:

Document Number	Document Description	File Name	File Size(Bytes)/ Message Digest	Multi Part /.zip	Pages (if appl.)
1	Response after non-final action-owner timely	A209779Amendmentasfiled.pdf	206140 9e1533469f71bbb3083ed5b526a84e00cd231ee	no	59

Warnings:

Information:

2	Fee Worksheet (SB06)	fee-info.pdf	30510 a5e3146bdd66e6f3da080f5658f418a33a391f0	no	2
---	----------------------	--------------	--	----	---

Warnings:

Information:

Total Files Size (in bytes): 236650

This Acknowledgement Receipt evidences receipt on the noted date by the USPTO of the indicated documents, characterized by the applicant, and including page counts, where applicable. It serves as evidence of receipt similar to a Post Card, as described in MPEP 503.

New Applications Under 35 U.S.C. 111

If a new application is being filed and the application includes the necessary components for a filing date (see 37 CFR 1.53(b)-(d) and MPEP 506), a Filing Receipt (37 CFR 1.54) will be issued in due course and the date shown on this Acknowledgement Receipt will establish the filing date of the application.

National Stage of an International Application under 35 U.S.C. 371

If a timely submission to enter the national stage of an international application is compliant with the conditions of 35 U.S.C. 371 and other applicable requirements a Form PCT/DO/EO/903 indicating acceptance of the application as a national stage submission under 35 U.S.C. 371 will be issued in addition to the Filing Receipt, in due course.

New International Application Filed with the USPTO as a Receiving Office

If a new international application is being filed and the international application includes the necessary components for an international filing date (see PCT Article 11 and MPEP 1810), a Notification of the International Application Number and of the International Filing Date (Form PCT/RO/105) will be issued in due course, subject to prescriptions concerning national security, and the date shown on this Acknowledgement Receipt will establish the international filing date of the application.

PATENT APPLICATION

IN THE UNITED STATES PATENT AND TRADEMARK OFFICE

In re application of

Docket No: A209779

Theodore L. Brann

Appln. No.: 90/013,201

Group Art Unit: 3993

Confirmation No.: 9930

Examiner: DEMILLE, DANTON D

Filed: April 4, 2014

For: TRAINING AND SAFETY DEVICE, SYSTEM AND METHOD TO AID IN PROPER
MOVEMENT DURING PHYSICAL ACTIVITY

STATEMENT OF SUBSTANCE OF INTERVIEW

Commissioner for Patents
P.O. Box 1450
Alexandria, VA 22313-1450

Sir:

Please review and enter the following remarks summarizing the personal interview conducted on September 3, 2014.

As an initial matter, Applicant's representatives thank the Examiners for the courtesies extended during the personal interview.

During the interview, differences between dependent claims 30, 32, 33, 60, 61, and 67 and the cited references (primarily Flentov, Vock, and Burdea) were discussed.

The Examiner's Interview Summary dated September 12, 2014 additionally lists claims 76, 77, 103, 119, 120, and 146 as being discussed during the interview. It is noted that these claims recite features similar to *at least* some of the dependent claims listed above.

With respect to the "time stamp" feature set forth in claims 30, 32, and 33, the Examiners indicated that the claims, as currently drafted, may not reflect the feature as intended to be

interpreted by the Patent Owner. Some proposed clarifying amendments were discussed in this regard.

There was a similar discussion regarding claims 60, 61, and 67 relating to the storage of a plurality of thresholds corresponding to a plurality of notifications, and how the threshold relates to a user-defined event in the claims. The Examiners thought that the claims broadly read on a certain interpretation of the cited reference(s). Again, some possibly clarifying amendments were generally discussed that would preclude the claims from being read on the cited reference(s).

The Examiners agreed that if a formal response is filed with clarifying amendments along the lines discussed during the interview, the Examiners would reconsider their current position regarding the combination of Flentov/Vock with Burdea.

It is respectfully submitted that the instant STATEMENT OF SUBSTANCE OF INTERVIEW complies with the requirements of 37 C.F.R. §§1.2 and 1.133 and MPEP §713.04.

It is believed that no petition or fee is required. However, if the USPTO deems otherwise, Patent Owner hereby petitions for any extension of time which may be required to maintain the pendency of this case, and any required fee, except for the Issue Fee, for such extension is to be charged to Deposit Account No. 19-4880.

Respectfully submitted,

/Abdul-Quadeer Ahmed/

SUGHRUE MION, PLLC
Telephone: 202.293.7060
Facsimile: 202.293.7860

WASHINGTON OFFICE

23373

CUSTOMER NUMBER

Date: October 3, 2014

Quadeer A. Ahmed
Registration No. 60,835

Electronic Acknowledgement Receipt

EFS ID:	20321319
Application Number:	90013201
International Application Number:	
Confirmation Number:	9930
Title of Invention:	TRAINING AND SAFETY DEVICE, SYSTEM AND METHOD TO AID IN PROPER MOVEMENT DURING PHYSICAL ACTIVITY
First Named Inventor/Applicant Name:	6059576
Customer Number:	23373
Filer:	Quadeer A. Ahmed/Shanele Jones
Filer Authorized By:	Quadeer A. Ahmed
Attorney Docket Number:	A209779
Receipt Date:	03-OCT-2014
Filing Date:	04-APR-2014
Time Stamp:	12:10:05
Application Type:	Reexam (Patent Owner)

Payment information:

Submitted with Payment	no
------------------------	----

File Listing:

Document Number	Document Description	File Name	File Size(Bytes)/ Message Digest	Multi Part /.zip	Pages (if appl.)
1	Applicant summary of interview with examiner	A209779StatementofSubstanc eofInterviewasfiled.pdf	22333 <small>7e7facfa626ee54dd3a4a1cfc9e37451ff4afc a7</small>	no	2

Warnings:

Information:

This Acknowledgement Receipt evidences receipt on the noted date by the USPTO of the indicated documents, characterized by the applicant, and including page counts, where applicable. It serves as evidence of receipt similar to a Post Card, as described in MPEP 503.

New Applications Under 35 U.S.C. 111

If a new application is being filed and the application includes the necessary components for a filing date (see 37 CFR 1.53(b)-(d) and MPEP 506), a Filing Receipt (37 CFR 1.54) will be issued in due course and the date shown on this Acknowledgement Receipt will establish the filing date of the application.

National Stage of an International Application under 35 U.S.C. 371

If a timely submission to enter the national stage of an international application is compliant with the conditions of 35 U.S.C. 371 and other applicable requirements a Form PCT/DO/EO/903 indicating acceptance of the application as a national stage submission under 35 U.S.C. 371 will be issued in addition to the Filing Receipt, in due course.

New International Application Filed with the USPTO as a Receiving Office

If a new international application is being filed and the international application includes the necessary components for an international filing date (see PCT Article 11 and MPEP 1810), a Notification of the International Application Number and of the International Filing Date (Form PCT/RO/105) will be issued in due course, subject to prescriptions concerning national security, and the date shown on this Acknowledgement Receipt will establish the international filing date of the application.



UNITED STATES PATENT AND TRADEMARK OFFICE

UNITED STATES DEPARTMENT OF COMMERCE
United States Patent and Trademark Office
Address: COMMISSIONER FOR PATENTS
P.O. Box 1450
Alexandria, Virginia 22313-1450
www.uspto.gov

APPLICATION NO.	FILING DATE	FIRST NAMED INVENTOR	ATTORNEY DOCKET NO.	CONFIRMATION NO.
-----------------	-------------	----------------------	---------------------	------------------

90/013,201	04/04/2014	6059576	A209779	9930
------------	------------	---------	---------	------

23373 7590 09/12/2014
 SUGHRUE MION, PLLC
 2100 PENNSYLVANIA AVENUE, N.W.
 SUITE 800
 WASHINGTON, DC 20037

EXAMINER

DEMILLE, DANTON D

ART UNIT	PAPER NUMBER
----------	--------------

3993

MAIL DATE	DELIVERY MODE
-----------	---------------

09/12/2014

PAPER

Please find below and/or attached an Office communication concerning this application or proceeding.

The time period for reply, if any, is set in the attached communication.

Ex Parte Reexamination Interview Summary	Control No. 90/013,201	Patent Under Reexamination 6059576
	Examiner DANTON DE MILLE	Art Unit 3993

All participants (USPTO personnel, patent owner, patent owner's representative):

- | | |
|----------------------------|----------------------------|
| (1) <u>Danton De Mille</u> | (4) <u>Quadeer Ahmed</u> |
| (2) <u>Eileen Lillis</u> | (5) <u>Carl Pellegrini</u> |
| (3) <u>Robert Fetsuga</u> | (6) <u>William Mandir</u> |

Date of Interview: 03 September 2014

Type: a) Telephonic b) Video Conference
c) Personal (copy given to: 1) patent owner 2) patent owner's representative)

Exhibit shown or demonstration conducted: d) Yes e) No.
If Yes, brief description: _____

Agreement with respect to the claims f) was reached. g) was not reached. h) N/A.
Any other agreement(s) are set forth below under "Description of the general nature of what was agreed to..."

Claim(s) discussed: 32,33,60,76,77,103,119,120 and 146.

Identification of prior art discussed: art of record.

Description of the general nature of what was agreed to if an agreement was reached, or any other comments:
See Continuation Sheet.

(A fuller description, if necessary, and a copy of the amendments which the examiner agreed would render the claims patentable, if available, must be attached. Also, where no copy of the amendments that would render the claims patentable is available, a summary thereof must be attached.)

A FORMAL WRITTEN RESPONSE TO THE LAST OFFICE ACTION MUST INCLUDE PATENT OWNER'S STATEMENT OF THE SUBSTANCE OF THE INTERVIEW. (See MPEP § 2281). IF A RESPONSE TO THE LAST OFFICE ACTION HAS ALREADY BEEN FILED, THEN PATENT OWNER IS GIVEN **ONE MONTH FROM THIS INTERVIEW DATE TO PROVIDE THE MANDATORY STATEMENT OF THE SUBSTANCE OF THE INTERVIEW (37 CFR 1.560(b)). THE REQUIREMENT FOR PATENT OWNER'S STATEMENT CAN NOT BE WAIVED. **EXTENSIONS OF TIME ARE GOVERNED BY 37 CFR 1.550(c).****

/Danton De Mille/
Primary Examiner, Art Unit 3993

/RMF/

/EDL/

cc: Requester (if third party requester)

Continuation of Description of the general nature of what was agreed to if an agreement was reached, or any other comments:

Patent owner argued that the time stamp taught by Burdea is related to the update time at which point the patient data is updated at the database 114. Burdea's time stamp is associated with the entire physical therapy session when stored in database 114 and not when the movement data is stored. The instant invention's time stamp is related to the movement time at which the movement sensor senses the movement.

The Office's position is that the claims recite the time stamp is associated with the received movement data which is equivalent to the loft or "air" time recorded in Flentov. Flentov's invention is designed to record a plurality of movement data such as loft or "air" time which is recorded and stored. Burdea teaches storing patient data in database 114. Flentov's patent data would be the "air" time recorded and stored with the time stamp in order to provide a time history of patent information.

Discussed changes to better define the time stamp is associated with the time the user defined event occurs. Also discussed changes to better define the difference between the threshold and user defined events. No agreement was reached. Formal amendment will follow.

FAX COVER SHEET

TO	(Manual Fax Entry)
COMPANY	Fax Recipient
FAX NUMBER	15712734974
FROM	SUGHRUE MION
DATE	2014-08-29 17:51:08 EDT
RE	[9253] Agenda for Personal Interview (Control No. 90/013,201; Attorney Docket: A209779)

COVER MESSAGE

Dear Examiner DeMille,

Please find attached the agenda for the personal interview scheduled for September 3, 2014 at 1pm.

Looking forward to the meeting,

Best Regards,
Quadeer A. Ahmed

Sughrue Mion, PLLC | , Office: | Fax:

Warning: In rare cases, our e-mail filtering software may eliminate legitimate email from clients unnoticed. Therefore, if your mail contains important instructions, please make sure that we acknowledge receipt of those instructions.

This message is intended only for the designated recipient(s). It may contain confidential or proprietary information and may be subject to the attorney-client privilege or other confidentiality protections. If you are not a designated recipient, you may not review, copy or distribute this message. If you receive this in error, please notify the sender by reply e-mail to coordinate retrieval or deletion of this message. Thank you.

Control No.: 90/013,201
Atty. Docket No.: A209779

FOR DISCUSSION ONLY, DONOTENTER

Agenda for the Personal Interview

Date / time of Interview

September 3, 2014 at 1 PM

Scheduled Participants

Applicant's representative(s):	William H. Mandir, Reg. No. 32,156 Carl J. Pellegrini, Reg. No. 40,766 Chandran B. Iyer, Reg. No. 48,434 Quadeer A. Ahmed, Reg. No. 60,835 (202) 857-3207 (voice - Quadeer)
USPTO:	Examiner Danton DeMille (571) 272-4974 (voice) (571) 273-4974 (fax)

It is Applicant's intention that such an interview will lead to an agreeable resolution of the rejected claims.

Claims 1, 13, 20, 21, and 30-158 are all the claims subject to this reexamination. Claims 1, 13, and 20 are the independent claims.

During the interview, Applicant's representatives would appreciate the opportunity to primarily highlight the differences between some of the dependent claims and the cited references, as briefly discussed below.

Proposed amendments to overcome the rejections under 35 U.S.C. 112, second paragraph will also be discussed.

I. Burdea does not cure the deficient teachings of Flentov, Gaudet, and Vock with respect to the dependent claims

Burdea is cited for allegedly curing the deficient teachings of Flentov, Gaudet, and Vock with respect to many of the dependent claims 30-158. However, as discussed below in the context of some representative dependent claims, the dependent claims are patentable over the asserted combination of Burdea with Flentov, Gaudet, or Vock.

Claims 32, 76, and 119

Claims 32, 76, and 119 recite, in some variation, that the microprocessor retrieves said at least one time stamp from said real-time clock and associates the retrieved time stamp with said received movement data.

Claim 32 appears to be addressed at page 17 of the Office Action, but it is unclear here how the reference(s) are being applied to claim 32.

Control No.: 90/013,201
Atty. Docket No.: A209779

FOR DISCUSSION ONLY, DONOTENTER

Based on the discussion at page 15 of the Office Action, it appears that Burdea's col. 6, lines 30-33 are relied upon to teach the above-noted features. It is believed, however, that the Examiner is misinterpreting and/or misapplying the teachings of Burdea in this regard.

For instance, the cited portion of Burdea discloses that "[p]atient data can be stored in database 114 for statistical purposes. Database 114 can include a time stamp for providing a time history of updates of the patient information."

That is, the time stamp described in Burdea is related to the update time at which the patient data (allegedly the claimed movement data) is updated at the database 114.

On the other hand, in the claimed invention, the time stamp is related to the movement time at which the movement sensor senses the movement.

For example, as described at col. 6, lines 15-19 of the subject patent, "[a] significant feature of the device 12 of the present invention is that it gives instant information to the wearer at the moment of incorrect movement and also records the information for future reference and analysis. The device 12 monitors a wide variety of "events" and records each event with a date/time stamp..."

As such, rather than maintaining time stamps with respect to the times at which movement data is updated in a database (as disclosed by Burdea), in the claimed invention, the microprocessor (which is included in the claimed portable, self-contained device) retrieves at least one time stamp from the real-time clock and associates the retrieved time stamp with the received movement data.

Claims 33, 77, and 120

Claims 33, 77, and 120 recite, in some variation, that the microprocessor retrieves at least one time stamp from the real-time clock based on the occurrence of at least one of the user-defined events.

For example, as described at col. 6, lines 19-40, "[m]any different types of "events" may be defined to be monitored by the device 12. As previously stated, any movement which surpasses any identified angle limit of movement (based on the specific physical task being accomplished and the range of motion needed to execute the task properly) is a standard recordable event. In addition, the device will record when no discernable movement has occurred for a predetermined amount of time (idle function), when the wearer has pressed the MUTE switch in response to an alarm (MUTE function), when the wearer's speed of movement exceeds a predefined speed (quickness function),..."

So in the claimed invention, the occurrence of a user-defined event triggers the microprocessor to retrieve the time stamp from the real-time clock.

It is unclear from the Office Action how the Examiner intends to apply the reference(s) to these claim features (e.g., see page 17 of Office Action).

It appears that the Examiner is referring to "the speed and loft time" of Flentov as the user-defined events. However, the Examiner already seems to acknowledge that Flentov does not teach retrieval of any time stamps in relation to the movement data.

Moreover, it has been shown above that Burdea also does not teach this feature.

As such, it is believed that claims 33, 77, and 120 are patentable over the cited references.

Control No.: 90/013,201
Atty. Docket No.: A209779

FOR DISCUSSION ONLY, DONOTENTER

Claims 60, 103, and 146

Claims 60, 103, and 146 recite, in some variation, that the memory stores a plurality of thresholds respectively corresponding to a plurality of notifications.

For example, as disclosed with respect to a non-limiting embodiment at col. 7, lines 5-43 of the subject patent:

"... The user may program the microprocessor 32 with an array of functions for the device 12 to perform. Primary among these is the ability to change the angular levels at which notices will be generated in order to fulfill particular application needs. In this way, the user may choose the angular positions at which he wants to be warned when they are exceeded. In the preferred device, up to three angle limits may be monitored by the device; however, any number of angles may be tracked depending upon the application....

As mentioned above, once a wearer of the device 12 exceeds the first defined angle limit, a notice for that limit is given to the wearer. The notice may be a combination of a visual warning, a tactile warning, and/or an audible warning. The microprocessor 32 also stores the specific angle limit which was exceeded along with the date/time stamp. Upon exceeding the second defined angle, the wearer is issued a second notice which may be the same as or different from the first notice. These different notice characteristics may include a change in pitch for audible alarms, a difference in duration for tactile alarms, and/or a blinking, different colored, or other visual warning."

So an example of a threshold is an angular level/angle limit and an example of a corresponding notification is a visual warning. As discussed in the above-noted portion of the patent, multiple angle limits can be stored and upon exceeding each angle limit, the same or different notices can be given to the user (*see also*: claims 64 and 65).

At pages 21-22, it is asserted that **Flentov** discloses this feature because allegedly, "[w]hen the user starts and stops the collection of movement data, the user has set the threshold amount of movement data to collect to determine the total number of jumps during that period of time. The peak "air" time and the peak speed are additional thresholds that are saved in memory. Each of these threshold data points correspond to a plurality of notifications on the display."

However, it is unclear how the user's starting and stopping of the movement data collection corresponds to the plurality of thresholds stored in memory. Also, the peak "air" time and peak speed in Flentov are naturally not stored in advance since they are only obtained after analyzing the data collected from the sensor.

The start and stop signals or the peak air time/peak speed are not compatible with the plain and ordinary meaning of a threshold (e.g., see claim 61, which recites that "*when one of the plurality of thresholds is met*, the output indicator displays a corresponding one of the notifications").

Therefore, Flentov does not disclose storing a plurality of thresholds, let alone storing a plurality of thresholds respectively corresponding to a plurality of notifications.

Control No.: 90/013,201
Atty. Docket No.: A209779

FOR DISCUSSION ONLY, DONOTENTER

At page 49, it is asserted that **Vock** discloses storing "a plurality of thresholds respectively corresponding to a plurality of notifications such as peak speed and peak loft time. Each time the user sets the threshold, a new set of notifications would be stored along with the thresholds."

As noted above with respect to Flentov, the peak speed and peak loft time are naturally not stored in advance. Nor are they consistent with the plain and ordinary meaning of the term "threshold".

Therefore, Vock does not disclose storing a plurality of thresholds, let alone storing a plurality of thresholds respectively corresponding to a plurality of notifications.

II. Proposed amendments in relation to rejections under 35 U.S.C. 112

As shown in the attached Appendix, amendments are proposed to claims 93, 123, and 149 to address the rejections under 35 U.S.C. 112, second paragraph.

Further, with respect to claim 149, it is noted that this claim is directed to a method and thus it does not seem necessary to specify *what* is "receiving at least one of the plurality of the thresholds from a user." The Examiner questions "[i]s it the memory, the microprocessor, the external computer, etc.?" (Office Action, page 3).

It is noted, however, that the claims from which claim 149 depends do not introduce any of these components since these are method claims.

Nonetheless, to expedite prosecution, the proposed amendment to claim 149 recites "receiving, via the portable, self-contained movement measuring device, at least one of..."

III. Conclusion

In view of the foregoing, it is believed that the proposed arguments and amendments discussed above would overcome the relevant rejections of record and thus would place the subject claims in allowable condition.

However, if the Examiners have any additional suggestions for further clarifying the claimed subject matter and to advance prosecution, Applicant's representatives would welcome such suggestions during the personal interview.

Control No.: 90/013,201
Atty. Docket No.: A209779

FOR DISCUSSION ONLY, DONOTENTER

APPENDIX

PROPOSED AMENDMENTS TO THE CLAIMS

93. (PROPOSED AMENDMENT): The system of claim 92, wherein said downloaded movement data is configured to be analyzed by said user via said program.

123. (PROPOSED AMENDMENT): The method of claim 20, further comprising: continuously monitoring for said physical movement using a movement sensor of the portable, self-contained movement measuring device.

149. (PROPOSED AMENDMENT): The method of claim 146, further comprising: receiving, via the portable, self-contained movement measuring device, at least one of the plurality of the thresholds from a user.



UNITED STATES PATENT AND TRADEMARK OFFICE

UNITED STATES DEPARTMENT OF COMMERCE
United States Patent and Trademark Office
Address: COMMISSIONER FOR PATENTS
P.O. Box 1450
Alexandria, Virginia 22313-1450
www.uspto.gov

APPLICATION NO.	FILING DATE	FIRST NAMED INVENTOR	ATTORNEY DOCKET NO.	CONFIRMATION NO.
-----------------	-------------	----------------------	---------------------	------------------

90/013,201	04/04/2014	6059576	A209779	9930
------------	------------	---------	---------	------

23373 7590 08/13/2014
 SUGHRUE MION, PLLC
 2100 PENNSYLVANIA AVENUE, N.W.
 SUITE 800
 WASHINGTON, DC 20037

EXAMINER

DEMILLE, DANTON D

ART UNIT	PAPER NUMBER
----------	--------------

3993

MAIL DATE	DELIVERY MODE
-----------	---------------

08/13/2014

PAPER

Please find below and/or attached an Office communication concerning this application or proceeding.

The time period for reply, if any, is set in the attached communication.



DO NOT USE IN PALM PRINTER

(THIRD PARTY REQUESTER'S CORRESPONDENCE ADDRESS)

SUGHRUE MION, PLLC
2100 PENNSYLVANIA AVENUE, N.W.
SUITE 800
WASHINGTON, DC 20037

EX PARTE REEXAMINATION COMMUNICATION TRANSMITTAL FORM

REEXAMINATION CONTROL NO. 90/013,201.

PATENT NO. 6059576.

ART UNIT 3993.

Enclosed is a copy of the latest communication from the United States Patent and Trademark Office in the above identified *ex parte* reexamination proceeding (37 CFR 1.550(f)).

Where this copy is supplied after the reply by requester, 37 CFR 1.535, or the time for filing a reply has passed, no submission on behalf of the *ex parte* reexamination requester will be acknowledged or considered (37 CFR 1.550(g)).

Office Action in Ex Parte Reexamination	Control No. 90/013,201	Patent Under Reexamination 6059576	
	Examiner DANTON DE MILLE	Art Unit 3993	AIA (First Inventor to File) Status No

-- The MAILING DATE of this communication appears on the cover sheet with the correspondence address --

- a. Responsive to the communication(s) filed on _____.
 A declaration(s)/affidavit(s) under 37 CFR 1.130(b) was/were filed on _____.
- b. This action is made FINAL.
- c. A statement under 37 CFR 1.530 has not been received from the patent owner.

A shortened statutory period for response to this action is set to expire 2 month(s) from the mailing date of this letter. Failure to respond within the period for response will result in termination of the proceeding and issuance of an *ex parte* reexamination certificate in accordance with this action. 37 CFR 1.550(d). **EXTENSIONS OF TIME ARE GOVERNED BY 37 CFR 1.550(c).** If the period for response specified above is less than thirty (30) days, a response within the statutory minimum of thirty (30) days will be considered timely.

Part I THE FOLLOWING ATTACHMENT(S) ARE PART OF THIS ACTION:

- | | |
|---|---|
| 1. <input checked="" type="checkbox"/> Notice of References Cited by Examiner, PTO-892. | 3. <input type="checkbox"/> Interview Summary, PTO-474. |
| 2. <input checked="" type="checkbox"/> Information Disclosure Statement, PTO/SB/08. | 4. <input type="checkbox"/> _____. |

Part II SUMMARY OF ACTION

- 1a. Claims 1,13,20,21 and 30-158 are subject to reexamination.
- 1b. Claims 2-12,14-19 and 22-29 are not subject to reexamination.
2. Claims _____ have been canceled in the present reexamination proceeding.
3. Claims _____ are patentable and/or confirmed.
4. Claims 1,13,20,21 and 30-158 are rejected.
5. Claims _____ are objected to.
6. The drawings, filed on _____ are acceptable.
7. The proposed drawing correction, filed on _____ has been (7a) approved (7b) disapproved.
8. Acknowledgment is made of the priority claim under 35 U.S.C. § 119(a)-(d) or (f).
a) All b) Some* c) None of the certified copies have
1 been received.
2 not been received.
3 been filed in Application No. _____ .
4 been filed in reexamination Control No. _____ .
5 been received by the International Bureau in PCT application No. _____ .
- * See the attached detailed Office action for a list of the certified copies not received.
9. Since the proceeding appears to be in condition for issuance of an *ex parte* reexamination certificate except for formal matters, prosecution as to the merits is closed in accordance with the practice under *Ex parte* Quayle, 1935 C.D. 11, 453 O.G. 213.
10. Other: _____

cc: Requester (if third party requester)

Ex Parte Reexamination Office Action

Reexamination was requested and ordered for claims 1, 13, 20 and 21 of United States Patent Number 6,059,576 (hereinafter, “the ‘576 patent”). Patent owner also submitted new claims 30-158 at the time of filing. Therefore, this reexamination will be over claims 1, 13, 20, 21 and 30-158.

Prior Art Relied Upon by the Requester

Flentov et al.	(U.S. Pat. No. 5,636,146) cited by requester
Gaudet et al.	(U.S. Pat. No. 6,018,705) cited by requester
Vock et al.	(U.S. Pat. No. 6,266,623) cited by requester
Burdea et al.	(U.S. Pat. No. 5,429,140) cited by examiner

Claim Rejections

Claim Rejections - 35 USC § 112

Claims 93, 123, 149 are rejected under 35 U.S.C. 112(b) or 35 U.S.C. 112 (pre-AIA), second paragraph, as being indefinite for failing to particularly point out and distinctly claim the subject matter which the inventor or a joint inventor, or for pre-AIA the applicant regards as the invention.

Claim 93 fails to further limit the system that has already been set forth. Claim 93 merely recites that the downloaded movement data is analyzed by the user via said program. This does not further restrict the system already claimed. This merely describes the action of the user.

Regarding claim 123, there is no clear antecedent basis for “the portable, self-contained movement”.

Regarding claim 149, it is not clear *what* is “receiving at least one of the plurality of the thresholds from a user.” Is it the memory, the microprocessor, the external computer, etc.?

Claim Rejections - 35 USC § 102

Claims 1 and 20 are rejected under pre-AIA 35 U.S.C. 102(b) as being anticipated by Flentov et al.

Flentov teaches a portable, self-contained device 10 for monitoring movement of body parts 28 during physical activity, column 1, lines 6-10:

The invention relates generally to the measurement of the loft time and speed of a vehicle relative to the ground. Such measurements are particularly useful in sporting activities like skiing and mountain biking where users desire information relating to their speed and/or loft, or "air" time.

The device 10 comprising a movement sensor 18, 20, capable of measuring data associated with unrestrained movement in any direction and generating signals indicative of said movement. The device 10 is attached to the ski of the user which would generate signals indicative of the unrestrained movement as the user freely navigates over the downhill course. The device also includes a power source 22.

A microprocessor subsystem 12 is also taught capable of receiving, interpreting, storing and responding to said movement data based on user-defined operational parameters from user input 14. The device includes at least one user input 14 in the form of at least buttons 58, 60, 62, 66 and 67. Flentov teaches in column 2, lines 36-40, “a user interface for providing external

inputs to the apparatus, including one or more of the following: a start/stop button for selectively starting and stopping the acquisition of data by the apparatus”.

As noted above, the movement sensor 18, 20 send signals indicative of the unrestrained movement to the microprocessor subsystem 12. The microprocessor 12 interprets the signals from the sensor, column 6, lines 19-22:

The speed information and loft time information are processed by the microprocessor subsystem 12 to quantify actual speed, e.g., in miles per hour, and actual loft time, e.g., in seconds.

The microprocessor stores the information, column 6 in lines 22-25, “[t]he actual speed and loft time are thereafter stored in internal memory 13”.

The microprocessor responds to the movement data based on user-defined operational parameters from the user input 14. Figure 4 illustrates a graph 70 of a representative vibrational spectrum 72 that is stored into the microprocessor subsystem 12, column 10, lines 29-37:

The vibrational spectrum between t1 and t2 [FIG. 4] is comparatively smooth as compared to the spectrum outside this region because the user's sporting vehicle (e.g., the ski or mountain bike) is in the air and is not therefore subjected to the random vibrations of the road or ski slope. Accordingly, this relatively smooth spectrum between t1 and t2 can be readily discerned from the rest of the spectrum by the microprocessor subsystem 12 and evaluated for "air" time: specifically, "air" time is t2-t1.

The microprocessor subsystem 12 responds to the vibrational spectrum 72 of the movement data based on user-defined operational parameters such as loft or “air” time derived from the “relatively smooth spectrum” between t1 and t2. The information is then displayed on display 16.

Flentov teaches many different embodiments for the speed sensor and the loft sensor. In column 17 Flentov teaches a loft sensor that is accelerometer based. In column 17, lines 24-37:

FIG. 13 illustrates a speed sensor 200 constructed according to the invention and which includes a plurality of accelerometers 202a-202d. The accelerometers 202a-202d sense various accelerations in their respective axes (accelerometers sense acceleration along a predefined axis, translational or rotational), and each of the outputs from the accelerometers are input to the microprocessor subsystem 204, e.g., the subsystem 12 of FIG. 1, via communication lines 206a-206d. The orientation of the sensitive axis of each accelerometer 202a-202d is stored in the microprocessor subsystem 204 so that a particular acceleration in one axis is properly combined with acceleration values in other axes (as described in more detail below in connection with FIGS. 14 and 14a).

Additionally, Flentov teaches in lines 58-62 of column 17:

It should be clear to those skilled in the art that fewer, or greater, numbers of accelerometers are within the scope of the invention, so long as they collectively determine speed. In effect, the fewer number of accelerometers results in reduced accuracy; not reduced functionality. Rather, in an ideal situation, one accelerometer can be used to detect speed; which is the integral of the acceleration over time. Further, a double integration over the same period provides distance; and, therefore, the invention can also provide distance in at least one embodiment of the invention.

Flentov teaches that one accelerometer can be used to detect speed and distance.

Flentov also teaches in column 18, lines 17-20 of using six accelerometers:

Specifically, six accelerometers are connected with various sensitive orientations to collect pitch 207a yaw 207b, roll 207c, surge 207d, heave 207e, and sway 207f accelerations.

Flentov also teaches how to derive speed and direction in column 18, lines 52-61:

Also shown in FIG. 14A are translational integrators 209a-209c which convert the compensated accelerations from inputs 207d-207f to translational velocities by integration. Integrators 210a-210c likewise integrate inputs of pitch 207a, yaw 207b, and roll 207c to angular velocity while integrators 211a-211c provide a further integration to convert the angular velocities to angular position. The angular positional information and translational velocity information is combined and processed at the speed and direction resolution section 212 to derive speed and direction.

Therefore, the movement sensor 200 measures the speed, angle and velocity of the movement. Speed and direction are calculated using the signals from the plural accelerometers of

the speed sensor 200. The direction is an angle of the movement of the device in at least two axes i.e., horizontal and vertical.

Therefore, Flentov teaches speed sensor 200 provides a movement sensor that measures the angular position and translational velocity.

Flentov teaches the microprocessor subsystem 12 includes a clock element in column 9, lines 28-34:

the microprocessor subsystem 12 of FIG. 1 preferably includes a clock element (readily known to those skilled in the art) for indicating processed time over a selectable period (the microprocessor subsystem 12 can in fact include a 24-hour clock element, much the way a digital wrist-watch includes 24-hour information).

While the 24-hour clock element of Flentov is not recited as “a real-time clock” however, it is a computer clock that keeps track of the current time in order to determine loft time.

Therefore it would appear that the 24-hour clock element recited by Flentov is “a real-time clock” for purposes of storing time in human units. This is different from hardware clocks which are only signals that govern digital electronics.

Flentov teaches an output indicator 16.

Therefore, it would appear that Flentov anticipates the invention as broadly claimed.

Claims 1 and 20 are rejected under 35 U.S.C. 102(e) as being clearly anticipated by Gaudet et al.

Gaudet teaches a portable, self-contained device and method of monitoring physical movement of a body part comprising attaching a portable, self-contained movement measuring device 20, for example, to the body for measuring unrestrained movement in any direction. The movement measuring device 20 is attached to the body of the user. The user

moves unrestrained in any direction. The movement measuring device 20 measures acceleration in any direction the user moves.

Gaudet teaches in column 4, lines 51-53, “[e]ach of devices 20A-20C shown in FIG. 2 has a particular axis in which it senses acceleration, i.e., an acceleration sensing axis.” However, because the device 20A-20C is attached to the body of the user, the movement of the device has unrestrained movement in any direction as the user moves in any direction and therefore, the acceleration sensing axis will also move unrestrained in any direction. The foot contact time/foot loft time generators 20A-20C will generate acceleration signals along that axis. The axis of the device is oriented substantially parallel to a bottom surface of the foot of the user. The rate of travel is the speed of travel along the acceleration sensing axis. Therefore, the movement sensor 20A-20C measures the angle and velocity of the movement.

Gaudet teaches in column 2, lines 16-20:

By calculating an average of these several measured foot contact times, an average foot contact time may be determined, from which information such as the pace of the user, rate of travel, distance traveled, etc., may be calculated.

The pace of the user, rate of travel and the distance traveled by the user are determined from the “foot contact times” and the “foot loft times”.

Column 4, lines 10-22, figure 1 shows a:

network 70 includes network processing circuitry 30, a memory unit 28, a user interface 32, a display 26A, and an audio or vibrational indicator 26B. Network processing circuitry 30 also is coupled to receive inputs from one or more monitoring devices, such as foot contact time/foot loft time generators 20A and 20B, heart rate monitor 22, and respiratory monitor 24. The devices shown in FIG. 1 may be linked together, for example, via direct wiring or capacitive coupling, by using radio-frequency (RF) or infra-red (IR) transmitters/receivers, or by any other information transmission medium known to those skilled in the art.

The monitoring devices include movement sensors or foot contact time/foot loft time generators 20A and 20B. The movement sensors 20A, 20B transmit movement data using transmitters/receivers. Transmitters/receivers require power to transfer and receive data. Obviously there is a power source within the movement sensors 20A and 20B in order to transmit data.

The network processing circuitry 30 interprets the movement data based on user-defined operational parameters, column 4, lines 28-33:

User interface 32 also is coupled to network processing circuitry 30 and permits a user, e.g., a walker, jogger or runner, to select a particular feature implemented by operation of a software routine, to input particular operating parameters, or to select particular outputs for display 26A and/or audio or vibrational indicator 26B.

Gaudet also teaches in column 4, lines 22-27:

Network processing circuitry 30 may include a personal computer, or any other device capable of processing information from the various inputs of network 70. Memory unit 28 is coupled to network processing circuitry 30 and is used to store programming and data for network processing circuitry 30 and/or to log data processed by circuitry 30.

Gaudet teaches a memory unit 28 is coupled to network processing circuitry 30 and is used to store programming and data for network processing circuitry 30 and/or to log data processed by circuitry 30.

Gaudet also teaches using timers, column 5, lines 12-14 (emphasis added):

According to one embodiment, foot contact time/foot loft time generator 20 includes a micro-controller having virtually all circuitry, e.g., memory, *timers* and analog-to-digital (A/D) converters, on board, so that memory unit 54 need only be used to perform functions such as permanently storing data produced by foot contact time/foot loft time generator 20.

Gaudet teaches a timer is part of the movement measuring device 20. The timers are used to measure time periods in seconds. Gaudet teaches in column 9, lines 10-15:

The time measured by the air time (Ta) timer represents the time difference between the last "positive spike event" (defined below) and the negative spike event just detected. When a negative spike event occurs, a "StepCount" value, i.e., a counted number of footsteps of the user, also is increment.

Air time timer Ta measure the time difference between the last positive spike event to the negative spike event. Therefore as defined by the instant invention, Gaudet records in real-time the time between the negative spike event and the positive spike event. This timer would appear to be a real-time clock because the timer records the time. It would appear that Gaudet anticipates the invention as broadly claimed.

Claims 1 and 20 are rejected under 35 U.S.C. 102(e) as being clearly anticipated by Vock et al.

Vock teaches a self-contained device 10 comprising a movement sensor 18, a power source 22, a microprocessor 12, a user input 14, memory 13 and an output indicator 16 or display.

The movement sensor 18 measures data associated with unrestrained movement in any direction and generating signals indicative of said movement. As shown in figure 2 the portable, self-contained device 10 is mounted to the ski of the user. The user can manipulate the skis in an unrestrained movement in any direction. The sensor 18 generates signals indicative of the unrestrained movement.

The microprocessor 12 is connected to the movement sensor 18 and the power source 22 and is capable of receiving, interpreting, storing and responding to the movement data based on user-defined operational parameters. Vock teaches in column 8, lines 3-22:

Briefly, the invention shown in FIG. 1 operates as follows. The housing 24 is attached or mounted to a sporting device, such as a ski or mountain bike, such that a user of the ski or mountain bike can access the system 10. During motion of the ski or mountain bike, the speed sensor 18 sends velocity information (over communication line 11a) to the microprocessor subsystem 12; while the loft sensor 20 sends loft or "air" time information (over communication line 11b) to the microprocessor subsystem 12. The speed information and loft time information are processed by the microprocessor subsystem 12 to quantify actual speed, e.g., in miles per hour, and actual loft time, e.g., in seconds. The actual speed and loft time are thereafter stored in internal memory 13 until, at least, the speed and time data are accessed by a user of the system 10. Upon access through the user interface 14 (communicating with the microprocessor subsystem 12 via communication line 11c), a user of the system 10 can command the display of the speed and loft time data (sent across communication line 11d) on the display 16 in order to evaluate his or her performance in the sporting activity.

The user, through the user interface 14, commands the microprocessor 12 to display the speed and loft time data on the display 16 in order to evaluate his or her performance in the sporting activity.

Vock also teaches a clock element in column 3, lines 17-21:

Preferably, the microprocessor subsystem of the invention includes a [clock] element, e.g., a 24-hour clock, for providing information convertible to an elapsed time. Accordingly, the subsystem can perform various calculations, e.g., dead time, on the data acquired by the apparatus for display to a user.

The clock of Vock appears to be used for calculating the various elapsed times. These elapsed times would be real-time because it is measuring time in human terms and therefore would appear to comprehend the claimed real-time clock.

Vock teaches many different types of speed and loft sensors for acquiring velocity and loft or "air" time. In one embodiment of column 21 the speed sensor is pressure based. In this embodiment the speed sensor of Vock measures the angle and velocity of the movement. In column 21, lines 47-59:

Pressure sensors according to the invention convert air pressure to an analog voltage. When mounted to a snowboard 220, such as shown in FIGS. 15 and 15A, the pressure sensor 221 is used to determine the altitude of the snowboarder. This voltage is read by the microprocessor subsystem (e.g., the subsystem 12 of FIG. 1) at a fixed rate and differentiated to determine rate of descent or speed in the vertical direction. This may be converted to speed along the path by knowing the grade or angle of descent. Angle of descent is known by predetermining the geometry of the ski path or by the addition of an inclinometer 222 which gives a voltage dependent upon the angle, with respect to vertical, of the platform. The inclinometer 222 measures zero when the ski is traveling along a level path and the pressure sensor is showing a constant pressure. When the ski moves downhill, for example, the inclinometer 222 measures the angle of descent and the pressure sensor measures ever increasing pressure. Since the angle of descent is known, as is the rate of descent, the true speed is determined and displayed.

Vock teaches the speed sensor includes a pressure sensor 221 to determine the altitude of the user and inclinometer 222 gives a voltage dependent upon the angle with respect to vertical. The pressure sensor 221 determines the speed of vertical descent and the inclinometer 222 determines the angle. Since the angle of descent is known, and the rate of descent is known, the true speed is determined and displayed. Therefore, it would appear that Vock anticipates the invention as broadly recited.

Claims 1, 13, 20, 21, 30-158 are rejected under pre-AIA 35 U.S.C. 103(a) as being unpatentable over Flentov et al. in view of Burdea et al.

Regarding claims 1, 13, 20, 21, 125-128 Flentov teaches a portable, self-contained device 10 for monitoring movement of body parts 28 during physical activity, column 1, lines 6-10:

The invention relates generally to the measurement of the loft time and speed of a vehicle relative to the ground. Such measurements are particularly useful in sporting activities like skiing and mountain biking where users desire information relating to their speed and/or loft, or "air" time.

The device 10 comprising a movement sensor 18, 20, capable of measuring data associated with unrestrained movement in any direction and generating signals indicative of said movement. The device 10 is attached to the ski of the user which would generate signals indicative of the unrestrained movement as the user freely navigates over the downhill course. The device also includes a power source 22.

A microprocessor subsystem 12 is also taught capable of receiving, interpreting, storing and responding to said movement data based on user-defined operational parameters from user input 14. The device includes at least one user input 14 in the form of at least buttons 58, 60, 62, 66 and 67. Flentov teaches in column 2, lines 36-40, "a user interface for providing external inputs to the apparatus, including one or more of the following: a start/stop button for selectively starting and stopping the acquisition of data by the apparatus".

As noted above, the movement sensor 18, 20 send signals indicative of the unrestrained movement to the microprocessor subsystem 12. The microprocessor 12 interprets the signals from the sensor, column 6, lines 19-22:

The speed information and loft time information are processed by the microprocessor subsystem 12 to quantify actual speed, e.g., in miles per hour, and actual loft time, e.g., in seconds.

The microprocessor stores the information, column 6 in lines 22-25, "[t]he actual speed and loft time are thereafter stored in internal memory 13".

The microprocessor responds to the movement data based on user-defined operational parameters from the user input 14. Figure 4 illustrates a graph 70 of a representative vibrational spectrum 72 that is stored into the microprocessor subsystem 12, column 10, lines 29-37:

The vibrational spectrum between t1 and t2 [FIG. 4] is comparatively smooth as compared to the spectrum outside this region because the user's sporting vehicle

(e.g., the ski or mountain bike) is in the air and is not therefore subjected to the random vibrations of the road or ski slope. Accordingly, this relatively smooth spectrum between t_1 and t_2 can be readily discerned from the rest of the spectrum by the microprocessor subsystem 12 and evaluated for "air" time: specifically, "air" time is $t_2 - t_1$.

The microprocessor subsystem 12 responds to the vibrational spectrum 72 of the movement data based on user-defined operational parameters such as loft or "air" time derived from the "relatively smooth spectrum" between t_1 and t_2 . The information is then displayed on display 16.

Flentov teaches many different embodiments for the speed sensor and the loft sensor. In column 17 Flentov teaches a loft sensor that is accelerometer based. In column 17, lines 24-37:

FIG. 13 illustrates a speed sensor 200 constructed according to the invention and which includes a plurality of accelerometers 202a-202d. The accelerometers 202a-202d sense various accelerations in their respective axes (accelerometers sense acceleration along a predefined axis, translational or rotational), and each of the outputs from the accelerometers are input to the microprocessor subsystem 204, e.g., the subsystem 12 of FIG. 1, via communication lines 206a-206d. The orientation of the sensitive axis of each accelerometer 202a-202d is stored in the microprocessor subsystem 204 so that a particular acceleration in one axis is properly combined with acceleration values in other axes (as described in more detail below in connection with FIGS. 14 and 14a).

Additionally, Flentov teaches in lines 58-62 of column 17:

It should be clear to those skilled in the art that fewer, or greater, numbers of accelerometers are within the scope of the invention, so long as they collectively determine speed. In effect, the fewer number of accelerometers results in reduced accuracy; not reduced functionality. Rather, in an ideal situation, one accelerometer can be used to detect speed; which is the integral of the acceleration over time. Further, a double integration over the same period provides distance; and, therefore, the invention can also provide distance in at least one embodiment of the invention.

Flentov teaches that one accelerometer can be used to detect speed and distance.

Flentov also teaches in column 18, lines 17-20 of using six accelerometers:

Specifically, six accelerometers are connected with various sensitive orientations to collect pitch 207a yaw 207b, roll 207c, surge 207d, heave 207e, and sway 207f accelerations.

Flentov also teaches how to derive speed and direction in column 18, lines 52-61:

Also shown in FIG. 14A are translational integrators 209a-209c which convert the compensated accelerations from inputs 207d-207f to translational velocities by integration. Integrators 210a-210c likewise integrate inputs of pitch 207a, yaw 207b, and roll 207c to angular velocity while integrators 211a-211c provide a further integration to convert the angular velocities to angular position. The angular positional information and translational velocity information is combined and processed at the speed and direction resolution section 212 to derive speed and direction.

Therefore, the movement sensor 200 measures the speed, angle and velocity of the movement. Speed and direction are calculated using the signals from the plural accelerometers of the speed sensor 200. The direction is an angle of the movement of the device in at least two axes i.e., horizontal and vertical.

Therefore, Flentov teaches speed sensor 200 provides a movement sensor that measures the angular position and translational velocity.

Flentov teaches the microprocessor subsystem 12 includes a clock element in column 9, lines 28-34:

the microprocessor subsystem 12 of FIG. 1 preferably includes a clock element (readily known to those skilled in the art) for indicating processed time over a selectable period (the microprocessor subsystem 12 can in fact include a 24-hour clock element, much the way a digital wrist-watch includes 24-hour information).

While the 24-hour clock element of Flentov is not recited as “a real-time clock” however, it is a computer clock that keeps track of the current time in order to determine loft time.

Therefore it would appear that the 24-hour clock element recited by Flentov is “a real-time

clock” for purposes of storing time in human units. This is different from hardware clocks which are only signals that govern digital electronics.

The instant invention defines the “real-time clock” in column 5, lines 33-37:

The microprocessor 32 is connected to a clock 46 which is used as an internal clock for coordinating the functioning of the microprocessor 32. The clock 46 also serves as a real time clock to provide date and time information to the microprocessor 32.

There does not appear to be any special definition for the term “real-time clock” as long as the clock serves to provide date and time information to the microprocessor.

Burdea teaches a method to monitor physical movement of a body part. The system employs an electronic device which tracks and monitors an individual’s motion through the use of sensors capable of measuring parameters associated with the individual’s movement. In column 6, lines 30-33,

Patient data can be stored in database 114 for statistical purposes. Database 114 can include a time stamp for providing a time history of updates of the patient information.

Burdea teaches the convention of storing performance data over time that includes a time stamp for providing a time history of updates. A clock would be required in order to associate a specific time and day with each piece of performance data, in order to evaluate the user’s progress over time. It would have been obvious to one of ordinary skill in the art to modify Flentov to include a date and time stamp as taught by Burdea in order to provide a time history of user’s performances to evaluate user's progress.

Regarding claims 13, 133-135, in addition to the limitations of claim 1, claim 13 also recites an input/output port, a computer capable of interpreting and reporting the movement data based on operational parameters, and a download device connected to the movement measuring

device and the computer for transmitting the movement data and operational parameters between the movement measuring device and the computer for analysis, reporting and operation purposes.

Burdea shows in figure 1, network 22 is capable of transmitting the movement data and operational parameters between the movement measuring device or sensing glove 30 and the remote computer 20. The remote workstation is used for receiving diagnostic information and communicating rehabilitation instructions to the movement measuring device. Burdea column 4, lines 46-50:

Remote workstation 20 can be coupled over network 22 to computer workstation 14. Remote workstation 20 can be used at a medical specialist location for receiving diagnostic information and communicating rehabilitation instructions to computer workstation 14.

Broadly, the network 22 includes the input/output port and the network card is the download device electronically connected to said movement measuring device 30 and a remote computer 20 for transmitting and receiving information. It would have been obvious to one of ordinary skill in the art to further modify Flentov to include an input/output port, computer and download device as taught by Burdea so that a remote specialist can review historical data and suggest new instructions.

Regarding claim 20, Flentov teaches a method of monitoring physical movement of a body part comprising the steps of attaching a portable, self-contained movement measuring device 10 to the body part of the ski 26 for measuring unrestrained movement in any direction. The sensor 200 measures data associated with physical movement and the microprocessor 13 interprets the physical movement data based on user-defined operational parameters from user input 14. Burdea teaches using a “real-time clock” for adding a time stamp to the movement data so that the user movement data can be stored for statistical purposes. It would have been

obvious to one of ordinary skill in the art to modify Flentov to include a "real-time clock" for adding a time stamp to the movement data as taught by Burdea to be stored in memory for statistical purposes.

Regarding claim 21, as set forth above in rejection of claim 1, Flentov teaches velocity data and angular movement data along with related date and time data as provided by Burdea. Flentov was modified to include the date and time stamp taught by Burdea.

Regarding claim 30, as noted above, Burdea teaches including a time stamp for associating the time/date stamp with the movement data for providing a time history of updates of the user performance for storing in memory.

Regarding claim 31, the microprocessor also stores in memory the date associated with the time stamp.

Regarding claim 32, the microprocessor retrieves the time stamp with the date from the real-time clock to associate the time stamp with the retrieved movement data.

Regarding claim 33, the microprocessor retrieves the time stamp from the real-time clock based on the occurrence of the user defined events which are the speed and loft time.

Regarding claim 34, the microprocessor identifies the user defined event based on interpretation of the movement data such as the fastest speed or the longest loft time.

Regarding claim 35, Flentov teaches "[t]he memory may be nonvolatile such as battery backed RAM or Electrically Erasable Programmable Read Only Memory (EEPROM)" column 14, lines 33-35. Therefore, the memory continues to store movement data in response to battery power being lost from said power source.

Regarding claim 36, Flentov teaches in column 2, lines 36-40, “a user interface for providing external inputs to the apparatus, including one or more of the following: a start/stop button for selectively starting and stopping the acquisition of data by the apparatus”. The movement sensor continuously checks for movement when the user presses the start button. It will stop checking for movement when the stop button is pushed.

Regarding claim 37, the microprocessor also continuously interprets movement data received from the movement sensor when the user presses the start button which is a user-defined operational parameter.

Regarding claim 38, the output indicator displays information based on the movement data. When the user requests speed data, the output indicator displays speed data.

Regarding claim 39, the output indicator displays the movement data and the time stamp associated with the movement data.

Regarding claim 40, the output indicator displays information based on movement data and the time stamp associated with the movement data.

Regarding claim 41, Flentov teaches in column 2, lines 38-40:

a start/stop button for selectively starting and stopping the acquisition of data by the apparatus;

The threshold of the movement data is met when the user stops the acquisition of data. The threshold limit is reached when the user hits the stop button. The output indicator displays the results such as speed and loft time.

Flentov also teaches in column 2, lines 40-45:

a display-operate button for activating the display means selectively; a speed/loft toggle button for alternatively commanding a display of loft time information and speed information of the vehicle

The output indicator displays information indicating that a threshold is met based on the movement data such as speed and loft time.

Regarding claim 42, the threshold is based on information provided by the user when the user starts the acquisition of data and continues until the user stops the acquisition of data.

Regarding claim 43, the microprocessor stores in memory all of the movement data including the peak threshold speed achieved during a given activity.

Regarding claim 44, as taught by Burdea, the microprocessor associates the time/date stamp with each piece of movement data, including the peak threshold, in order to store the user's performance data for statistical purposes.

Regarding claim 45, one of ordinary skill in the art having devices that include batteries would require some form of output to let the user know when the batteries are about to die.

Regarding claim 46, Flentov teaches at the top of column 2, the display can be a LCD or LED display.

Regarding claim 47, the movement data stored in memory is configured to be downloaded to a computer. Any data stored in memory can be downloaded to a computer.

Regarding claim 48, as noted above, Burdea teaches remote workstation 20 can be coupled over network 22 to computer workstation 14. Obviously, computer workstation 14 has software configured to communicate with external software in the remote workstation 20 wherein the external software is configured to present the downloaded movement data to the user in the display. It would have been obvious to download the physical activity from the local microprocessor to an external computer over a network as taught by Burdea in order to have the

information saved at a different location so the information can be analyzed and processed for improving the user's performance.

Regarding claim 49, the external software is configured to run on the external computer.

Regarding claim 50, the downloaded movement data is analyzed by said user via said external software.

Regarding claims 51, 136, 137, 138, 139, 140, the external software is configured to interpret the movement data and produce at least one report. The purpose of the external computer is to analyze the data and to communicate new instructions for the user to the local workstation 14. Producing reports on the movement data including historical data would be obvious to one of ordinary skill in the art in order to develop new instructions for the user. Burdea teaches, column 4, lines 43-50, the workstation 14 is coupled to hard copy device 18 for producing a hard copy of diagnostic information including rehabilitation progress charts. The external computer would be better adapted to generate reports. Such would have been an obvious provision in Vock.

Regarding claims 52, 140, the external software is configured to interpret the movement data and produce at least one history report. The purpose of the external computer is to analyze the historical data. Producing reports on the movement data including historical data would be obvious to one of ordinary skill in the art in order to develop new instructions for the user.

Regarding claim 53, the history report obviously includes dates and time of the movement data. This is how one can analyze the data over time in order to develop improved physical activity.

Regarding claim 54, the external software is configured to allow the user to program additional reports and histories with respect to the movement data.

Regarding claims 55, 141, the movement data is configured to be downloaded to the computer via a wired connection. Network 22 is a wired connection.

Regarding claims 56, 142, wireless connections are old and well known and an obvious equivalent means of communicating information from one computer to another.

Regarding claim 57, the microprocessor records, based on a threshold being met, the time and date of the threshold being met. As noted above regarding claim 41, the threshold is the peak speed during an activity. The microprocessor records, based on the peak speed being met, the time and date of the peak threshold being met. The microprocessor records the time and date for all movement data.

Regarding claim 58, the output indicator 52 provides a visual indicator to the user regarding the threshold being met in display 52 of Flentov.

Regarding claims 59, 129, Flentov teaches in column 8, lines 35-39:

In addition, the highest number displayed within the portion 68 refers to the total number of "air" times for the selected activity period (thus for example a user can determine the total number of jumps achieved for a given day).

The user would press the start/stop button to start recording the movement data and press the start/stop button again to complete the acquisition of data. The user has thus set the threshold of how much data to collect to determine the total number of jumps achieved for a given period of time.

Regarding claims 60, 130, 146, 147, the memory stores a plurality of thresholds respectively corresponding to a plurality of notifications. When the user starts and stops the

collection of movement data, the user has set the threshold amount of movement data to collect to determine the total number of jumps during that period of time. The peak “air” time and the peak speed are additional thresholds that are saved in memory. Each of these threshold data points correspond to a plurality of notifications on the display.

Regarding claims 61, 145, 147, when one of the plurality of thresholds is met, the output indicator displays a corresponding one of the notifications such as the peak “air” time or peak speed during a run.

Regarding claims 62, 148, the microprocessor determines whether any of the thresholds are met by interpreting the movement data with respect to the thresholds. After the microprocessor determines the speed of the user, it compares the speed with the highest speed recorded so far. The threshold at any point in time is the highest speed recorded so far. As the microprocessor collects more and more speed data points it is comparing the current speed with the threshold speed recorded so far. Therefore as the microprocessor is interpreting the movement data with respect to the highest threshold at that time and if the movement data exceeds the highest threshold it will replace the highest threshold with the new threshold. At the end of the collection of movement data, the microprocessor has determined the threshold.

Regarding claim 63, as set forth above regarding claim 59, the user would press the start/stop button to start recording the movement data and press the start/stop button again to complete the acquisition of data. The user has thus set the threshold of how much data to collect to determine the total number of jumps achieved for a given period of time.

Regarding claim 64, as noted above regarding claim 62, the plurality of thresholds are different from each other until the final maximum threshold is recorded.

Regarding claim 65, the plurality of notifications are different visual indicators. The peak “air” time and the peak speed are two different notifications would be two different indicators in the display.

Regarding claim 66, the prior art has already established the user of using visual indicators and including a blinking indicator is old and well known and an obvious provision in the art of displaying information on a display screen. Where the general conditions of a claim are disclosed in the prior art, it is not inventive to discover the optimum or workable ranges by routine experimentation. *In re Swain et al.*, 33 CCPA (Patents) 1250, 156 F.2d 239, 70 USPQ 412; *Minnesota Mining and Mfg. Co. v. Coe*, 69 App. D.C. 217, 99 F.2d 986, 38 USPQ 213; *Allen et al. v. Coe*, 77 App. D.C. 324, 135 F.2d 11, 57 USPQ 136. Providing blinking lights to highlight a portion of the display is well within the realm of the artisan of ordinary skill in the art of displaying information on a display screen.

Regarding claims 67, 131, 144, 153, Flentov teaches in column 8, lines 32-33, when the microprocessor determines when a threshold has been met, the display will signal the occurrence that the user-defined threshold has been met by illustrating “1” as meaning that the threshold peak “air” time has been met.

Regarding claims 68, 154, as the microprocessor compares the movement data with the current speed threshold it will update the current speed threshold if the movement data is greater than the current speed threshold.

Regarding claims 69, 155, Flentov teaches in column 19, lines 12-16:

It should be apparent to those in the art that the accelerometers of FIG. 13-14 provide sufficiently detailed information such that the whole of the system according to the invention can be mounted to a user of the system directly, rather than directly to a vehicle.

The sensor can be mounted on the user of the system directly.

Regarding claims 70, 156, the sensor can be mounted on the arm of the user and therefore measures movement of the user's arm.

Regarding claims 71, 72, 157, as noted above, Flentov measures distance as well as speed. Flentov teaches in column 17, lines 63-66, "one accelerometer can be used to detect speed; which is the integral of the acceleration over time. Further, a double integration over the same period provides distance". Therefore, the movement sensor of Flentov would also measure walking distance if one so chooses.

Regarding claims 73, 116, 143, 158, as noted above, Burdea teaches including a time stamp for associating the time/date stamp with the movement data for providing a time history of updates of the user performance for storing in memory. The microprocessor also stores in memory the date associated with the time stamp. The microprocessor also continuously checks movement data received from the movement sensor when the user presses the start button which is a user-defined operational parameter. The output indicator displays information based on the movement data indicating that a threshold has been met such as the peak speed data or peak "air" time. The movement data stored in memory is configured to be downloaded to a computer. Any data stored in memory can be downloaded to a computer. The device comprises software configured to communicate with external software configured to run on a computer and present the downloaded movement data. The purpose of the external computer is to analyze the historical data. Producing reports on the movement data including historical data would be obvious to one of ordinary skill in the art in order to develop new instructions for the user. The memory stores a plurality of thresholds respectively corresponding to a plurality of notifications

such as peak speed and peak “air” time including the time/date of the movement data. The sensor can be mounted on the arm of the user and therefore measures movement of the user’s arm. A speed sensor on the arm of the user would be able to measure the speed of the user.

Regarding claims 74, 75, 143, as noted above, Burdea teaches including a time stamp for associating the time/date stamp with the movement data for providing a time history of updates of the user performance for storing in memory.

Regarding claim 76, the microprocessor retrieves the time stamp from the real-time clock and associates the time stamp with the received movement data as taught by Burdea.

Regarding claim 77, the output indicator is configured to signal the occurrence of user-defined events such as peak speed and peak “air” time, and the microprocessor retrieves the time stamp from the real-time clock based on the occurrence of at least one of the user-defined events.

Regarding claim 78, the microprocessor identifies the user-defined events such as peak speed and peak “air” time based on interpretation of the movement data.

Regarding claims 79, 122, memory continues to store movement data in response to battery power being lost from the power source because the memory is nonvolatile such as battery backed RAM or Electrically Erasable Programmable Read Only Memory (EEPROM)”, Flentov column 14, lines 33-35.

Regarding claims 80, 81, 123, 124, the microprocessor also continuously interprets movement data received from the movement sensor when the user presses the start button which is a user-defined operational parameter.

Regarding claim 82, the output indicator displays information based on movement data such as peak speed and peak “air” time.

Regarding claims 83 and 84, the output indicator displays information based on movement data such as peak speed and peak “air” time.

Regarding claims 85 and 86, the output indicator displays information indicating that a threshold is met such as peak speed and peak “air” time.

Regarding claim 87, memory stores the information indicating that the threshold is met such as peak speed and peak “air” time.

Regarding claim 88, memory stores the information indicating that the threshold is met such as peak speed and peak “air” time including a time stamp.

Regarding claims 89, 132, one of ordinary skill in the art having devices that include batteries would require some form of output to let the user know when the batteries are about to die.

Regarding claim 90, Flentov teaches at the top of column 2, the display can be a LCD or LED display.

Regarding claim 91, the movement data stored in the memory is configured to be downloaded to the computer as is any data stored in memory.

Regarding claims 92, 93, as noted above, Burdea teaches remote workstation 20 can be coupled over network 22 to computer workstation 14. Obviously, computer workstation 14 has software configured to communicate with external software in the remote workstation 20 wherein the external software is configured to present the downloaded movement data to the user in the display to be analyzed.

Regarding claim 94, the purpose of the external computer is to analyze the data and to communicate new instructions for the user to the local workstation 14. Producing reports on the

movement data including historical data would be obvious to one of ordinary skill in the art in order to properly analyze the data to develop new instructions for the user. Burdea teaches, column 4, lines 43-50, the workstation 14 is coupled to hard copy device 18 for producing a hard copy of diagnostic information including rehabilitation progress charts. Such can also be applied to the external computer 20.

Regarding claim 95, the external software is configured to interpret the movement data and produce at least one history report. The purpose of the external computer is to analyze the historical data. Producing reports on the movement data including historical data would be obvious to one of ordinary skill in the art in order to develop new instructions for the user.

Regarding claim 96, the history report obviously includes dates and time of the movement data. This is how one can analyze the data.

Regarding claim 97, the external software is configured to allow the user to program additional reports and histories with respect to the movement data.

Regarding claim 98, the movement data is configured to be downloaded to the computer via a wired connection. Network 22 is a wired connection.

Regarding claim 99, wireless connections are old and well known and an obvious equivalent means of communicating information over air waves.

Regarding claim 100, the microprocessor records, based on a threshold being met, the time and date of the threshold being met. As noted above regarding claim 41, the threshold is the peak speed during an activity. The microprocessor records, based on the peak speed being met, the time and date of the peak threshold being met. The microprocessor records the time and date for all movement data.

Regarding claim 101, the output indicator 16 provides a visual indicator to the user regarding the threshold being met such as peak speed and peak “air” time.

Regarding claims 102, 149, Flentov teaches in column 8, lines 35-39:

In addition, the highest number displayed within the portion 68 refers to the total number of “air” times for the selected activity period (thus for example a user can determine the total number of jumps achieved for a given day).

The user would press the start/stop button to start recording the movement data and press the start/stop button again to complete the acquisition of data. The user has thus set the threshold of how much data to collect to determine the total number of jumps achieved for a given period of time.

Regarding claim 103, memory stores a plurality of thresholds respectively corresponding to a plurality of notifications. Each of the thresholds of peak speed and peak “air” time would be store in memory.

Regarding claim 104, when one of the thresholds is met such as peak speed, the output indicator displays a corresponding notification of peak speed.

Regarding claim 105, the microprocessor determines whether any of the thresholds are met by interpreting the movement data with respect to the thresholds. After the microprocessor determines the speed of the user, it compares the speed with the highest speed recorded so far. The threshold at any point in time is the highest speed recorded so far. As the microprocessor collects more and more speed data points, it is comparing the current speed with the threshold speed recorded so far. Therefore, the microprocessor is interpreting the movement data with respect to the highest threshold at that time. If the movement data exceeds the highest threshold

it will replace the highest threshold with the new threshold. At the end of the collection of movement data, the microprocessor has determined the threshold.

Regarding claim 106, the user would press the start/stop button to start recording the movement data and press the start/stop button again to complete the acquisition of data. The user has thus set the threshold of how much data to collect to determine the total number of jumps achieved for a given period of time.

Regarding claims 107, 150, the plurality of thresholds are different from each other because peak speed is different from peak “air” time.

Regarding claims 108, 151, 152, the plurality of notifications are different visual indicators because the peak speed measures miles per hour, peak “air” time measures in seconds.

Regarding claims 109, 152, the prior art has already established the user of using visual indicators and including a blinking indicator is old and well known and an obvious provision in the art of displaying information on a display screen. Where the general conditions of a claim are disclosed in the prior art, it is not inventive to discover the optimum or workable ranges by routine experimentation. *In re Swain et al.*, 33 CCPA (Patents) 1250, 156 F.2d 239, 70 USPQ 412; *Minnesota Mining and Mfg. Co. v. Coe*, 69 App. D.C. 217, 99 F.2d 986, 38 USPQ 213; *Allen et al. v. Coe*, 77 App. D.C. 324, 135 F.2d 11, 57 USPQ 136. Providing blinking lights to highlight a portion of the display is well within the realm of the artisan of ordinary skill in the art of displaying information on a display screen.

Regarding claim 110, the microprocessor processes the movement data to determine whether a threshold is met e.g., maximum speed or maximum “air” time. The output indicator is configured to signal the occurrence of the user-defined events such as peak “air” time with “the

illustrated '1' number means the highest 'air' time record is currently being displayed", column 8, lines 32-34.

Regarding claim 111, the microprocessor interprets the movement data to determine whether the threshold is met by comparing the movement data to the threshold. The threshold is the highest or peak "air" time the microprocessor has determined so far. The microprocessor continually compares the current "air" time with the peak "air" time.

Regarding claim 112, Flentov teaches in column 19, lines 12-16:

It should be apparent to those in the art that the accelerometers of FIG. 13-14 provide sufficiently detailed information such that the whole of the system according to the invention can be mounted to a user of the system directly, rather than directly to a vehicle.

The sensor can be mounted on the user of the system directly e.g., the arm of the user.

Regarding claim 113, as quoted above, Flentov teaches that the whole of the system can be mounted to a user of the system directly, rather than directly to a vehicle. When attached to the arm of the user it will measure movement of the arm as well as the whole of the body. The system will still measure movement of the body and the ski as a whole.

Regarding claim 114, the system of Flentov measures distance as noted above regardless of whether the user is walking, running, skiing or biking.

Regarding claim 115, as noted above, the whole of the system 10 can be mounted to the use and therefore is wearable and measures distances including walking, running, skiing or biking.

Regarding claims 117, 118, 119, 120, as set forth above, Burdea teaches adding a time/date stamp to movement data that is stored in memory in order to create a time history of movement data.

Regarding claim 121, the microprocessor identifies the occurrence of at least one user-defined event such as "air" time that occurs between t1 and t2 in figure 4.

Claims 1, 13, 20, 21 and 30-40, 45-56, 69-72, 74-84, 89-99, 109, 112-115, 117-127, 132-142, 155-157 are rejected under pre-AIA 35 U.S.C. 103(a) as being unpatentable over Gaudet et al. in view of Burdea et al.

Regarding claims 1, 13, 30-34, 38, 39, 117-120, Gaudet teaches a method of monitoring physical movement of a body part comprising attaching a portable, self-contained movement measuring device 20, for example, to the body for measuring unrestrained movement in any direction. The movement measuring device 20 is attached to the body of the user. The user moves unrestrained in any direction. The movement measuring device 20 measures acceleration in any direction the user moves.

Gaudet teaches in column 4, lines 51-53, "[e]ach of devices 20A-20C shown in FIG. 2 has a particular axis in which it senses acceleration, i.e., an acceleration sensing axis." However, because the device 20A-20C is attached to the body of the user, the movement of the device has unrestrained movement in any direction as the user moves in any direction and therefore, the acceleration sensing axis will also move unrestrained in any direction. The foot contact time/foot loft time generators 20A-20C will generate acceleration signals along that axis. The axis of the device is oriented substantially parallel to a bottom surface of the foot of the user. The rate of travel is the speed of travel along the acceleration sensing axis. Therefore, the movement sensor 20A-20C measures the angle and velocity of the movement.

Gaudet teaches in column 2, lines 16-20:

By calculating an average of these several measured foot contact times, an average foot contact time may be determined, from which information such as the pace of the user, rate of travel, distance traveled, etc., may be calculated.

The pace of the user, rate of travel and the distance traveled by the user are determined from the “foot contact times” and the “foot loft times”.

Column 4, lines 10-22, figure 1 shows a:

network 70 includes network processing circuitry 30, a memory unit 28, a user interface 32, a display 26A, and an audio or vibrational indicator 26B. Network processing circuitry 30 also is coupled to receive inputs from one or more monitoring devices, such as foot contact time/foot loft time generators 20A and 20B, heart rate monitor 22, and respiratory monitor 24. The devices shown in FIG. 1 may be linked together, for example, via direct wiring or capacitive coupling, by using radio-frequency (RF) or infa-red (IR) transmitters/receivers, or by any other information transmission medium known to those skilled in the art.

The monitoring devices include movement sensors or foot contact time/foot loft time generators 20A and 20B. The movement sensors 20A, 20B transmit movement data using transmitters/receivers. Transmitters/receivers require power to transfer and receive data. Obviously there is a power source within the movement sensors 20A and 20B in order to transmit data.

The network processing circuitry 30 interprets the movement data based on user-defined operational parameters, column 4, lines 28-33:

User interface 32 also is coupled to network processing circuitry 30 and permits a user, e.g., a walker, jogger or runner, to select a particular feature implemented by operation of a software routine, to input particular operating parameters, or to select particular outputs for display 26A and/or audio or vibrational indicator 26B.

Gaudet also teaches in column 4, lines 22-27:

Network processing circuitry 30 may include a personal computer, or any other device capable of processing information from the various inputs of network 70. Memory unit 28 is coupled to network processing circuitry 30 and is used to store

programming and data for network processing circuitry 30 and/or to log data processed by circuitry 30.

Gaudet teaches a memory unit 28 is coupled to network processing circuitry 30 and is used to store programming and data for network processing circuitry 30 and/or to log data processed by circuitry 30.

Gaudet also teaches using timers, column 5, lines 12-14 (emphasis added):

According to one embodiment, foot contact time/foot loft time generator 20 includes a micro-controller having virtually all circuitry, e.g., memory, **timers** and analog-to-digital (A/D) converters, on board, so that memory unit 54 need only be used to perform functions such as permanently storing data produced by foot contact time/foot loft time generator 20.

Gaudet teaches a timer is part of the movement measuring device 20. Gaudet appears silent with the exact details of what type of timer is used however, Gaudet does teach "**permanently** storing data produced by the foot contact time/foot loft time generator 20" (emphasis added). If the information is **permanently** stored, the data would have to include date attributes to distinguish one day's data from another day's data. A real-time clock would be able to attribute a date and time to the data in order to differentiate data from different days.

Burdea is cited to teach the convention of storing data for statistical purposes by including a time stamp associated with the data thereby providing historical progress, see column 6, lines 30-33. Any conventional means to tag a date and time stamp to the movement data for providing statistical information over time would have been obvious to one of ordinary skill. A real-time clock is a well-known example of a means to provide a date and time stamp. It would have been obvious to one of ordinary skill in the art to modify Gaudet to associate a time stamp with the user data as taught by Burdea such as real-time clock in order to track the movement data over time.

Regarding claims 13, in addition to the limitations of claim 1, claim 13 also recites an input/output port, a computer capable of interpreting and reporting the movement data based on operational parameters, and a download device connected to the movement measuring device and the computer for transmitting the movement data and operational parameters between the movement measuring device and the computer for analysis, reporting and operation purposes.

Burdea shows in figure 1, network 22 is capable of transmitting the movement data and operational parameters between the movement measuring device or sensing glove 30 and the remote computer 20. The remote workstation is used for receiving diagnostic information and communicating rehabilitation instructions to the movement measuring device. Burdea column 4, lines 46-50:

Remote workstation 20 can be coupled over network 22 to computer workstation 14. Remote workstation 20 can be used at a medical specialist location for receiving diagnostic information and communicating rehabilitation instructions to computer workstation 14.

Broadly, the network 22 includes the input/output port and the network card is the download device electronically connected to said movement measuring device 30 and a remote computer 20 for transmitting and receiving information. It would have been obvious to one of ordinary skill in the art to further modify Gaudet to include an input/output port, computer and download device as taught by Burdea so that a remote specialist can review historical data and suggest new instructions.

Regarding claim 20, Gaudet teaches attaching a portable, self-contained movement measuring device 20A, 20B to the body part, measuring data associated with the physical movement where the networking processing circuitry 30 interprets the physical movement data

based on user-defined operational parameters and a real-time clock, as taught by Burdea. The data is then stored in memory 28.

Regarding claims 21, 39, Gaudet teaches “[e]ach of devices 20A-20C shown in FIG. 2 has a particular axis in which it senses acceleration, i.e., an acceleration sensing axis.” The speed or acceleration is along this “acceleration sensing axis”. Gaudet was modified to associate the date and time stamp taught by Burdea.

Regarding claim 35, conventional memory includes nonvolatile memory such as battery backed RAM or Electrically Erasable Programmable Read Only Memory (EEPROM). Such is well-known to the artisan of ordinary skill. EEPROM is a well-known form of Read Only Memory used to store small amounts of data that must be saved when power is removed. Therefore, the memory continues to store movement data in response to battery power being lost from said power source.

Regarding claims 36, 37, Gaudet teaches in column 8, lines 54-59:

Essentially, continuous-loop portion 101 continuously monitors the voltage across inputs 46 and 48 of micro-controller 40 to determine when negative and positive voltages differences (between inputs 46 and 48) in excess of predetermined thresholds occur. These negative and positive voltage differences are indicative, respectively, of the foot of a user impacting with and leaving the ground.

In figure 5 of Gaudet, the output of accelerometer 32 is fed into the amplifier circuit 38 whose output is input to the microcontroller 40. Therefore the microcontroller has a continuous-loop portion 101 that continuously monitors the voltage across amplified signals from the accelerometer.

Regarding claim 40, Gaudet teaches in column 1, lines 7-10:

It is known that useful information may be derived from the measurement of the "foot contact time" of a person in locomotion, wherein "foot contact time" refers

to the period of time that a foot of a person is in contact with the ground during a stride taken by the person. Once the foot contact time of a person is known, other information, such as rate of travel, distance traveled and ambulatory expended energy may be calculated based upon this measured foot contact time.

Additionally, Gaudet teaches in column 4, lines 29-34:

User interface 32 also is coupled to network processing circuitry 30 and permits a user, e.g., a walker, jogger or runner, to select a particular feature implemented by operation of a software routine, to input particular operating parameters, or to select particular outputs for display 26A and/or audio or vibrational indicator 26B.

When the user selects useful information that can be derived from the measurement of the “foot contact time”, it is displayed from the output indicator which is based on movement data and the time stamp provided by Burdea.

Regarding claims 45, 132, Gaudet teaches the foot contact time/foot loft time generators 20 include a battery in column 6, lines 3-4. One of ordinary skill in the art having battery operated devices would require some form of output to let the user know when the batteries are about to die.

Regarding claims 46, 90, Gaudet appears silent with regard to exactly what type of displays 26A, 56A are used. Any conventional display would have been obvious to anyone of ordinary skill in the art. LEDs and LCDs are well-known examples of displays to display information to the user. Such would have been an obvious provision in the modification of Gaudet.

Regarding claims 47, 91, 133, the movement data stored in memory is configured to be downloaded to a computer. Any data stored in memory can be downloaded to a computer.

Regarding claims 48, 92, 93, 134, as noted above, Burdea teaches remote workstation 20 can be coupled over network 22 to computer workstation 14. Obviously, computer workstation

14 has software configured to communicate with external software in the remote workstation 20 wherein the external software is configured to present the downloaded movement data to the user in the display. Remote workstation 20 is for receiving performance data, analyze data and communicate new rehabilitation instructions to computer workstation 14.

Regarding claims 49, 135, the external software is configured to run on the external computer.

Regarding claims 50, the downloaded movement data is displayed by said external software and can be analyzed by the user.

Regarding claims 51, 136-140, the external software is configured to interpret the movement data and produce at least one report. The purpose of the external computer is to analyze the data and to communicate new instructions for the user to the local workstation 14. Producing reports on the movement data including historical data would be obvious to one of ordinary skill in the art in order to develop new instructions for the user. Burdea teaches, column 4, lines 43-50, the workstation 14 is coupled to hard copy device 18 for producing a hard copy of diagnostic information including rehabilitation progress charts.

Regarding claims 52, 140, the external software is configured to interpret the movement data and produce at least one history report. The purpose of the external computer is to analyze the historical data. Producing reports on the movement data including historical data would be obvious to one of ordinary skill in the art in order to develop new instructions for the user.

Regarding claims 53, 139, the history report obviously includes dates and time of the movement data. This is how one can analyze the data in order to develop instructions to improve the user's physical ability.

Regarding claims 54, 140, the external software is configured to allow the user to program additional reports and histories with respect to the movement data.

Regarding claims 55, 141, the movement data is configured to be downloaded to the computer via a wired connection. Network 22 is a wired connection.

Regarding claims 56, 142, wireless connections are old and well known and an obvious equivalent means of communicating information.

Regarding claims 109, the prior art has already established the convention of using visual indicators to display different results. Using a blinking indicator is old and well known and an obvious provision in the art of displaying information on a display screen in order to highlight one particular piece of data. Where the general conditions of a claim are disclosed in the prior art, it is not inventive to discover the optimum or workable ranges by routine experimentation. *In re Swain et al.*, 33 CCPA (Patents) 1250, 156 F.2d 239, 70 USPQ 412; *Minnesota Mining and Mfg. Co. v. Coe*, 69 App. D.C. 217, 99 F.2d 986, 38 USPQ 213; *Allen et al. v. Coe*, 77 App. D.C. 324, 135 F.2d 11, 57 USPQ 136. Providing blinking lights to highlight a portion of the display is well within the realm of the artisan of ordinary skill in the art of displaying information on a display screen.

Regarding claims 69, 112, 155, Gaudet teaches the sensors 20A-20C are placed on the body. The sensors can also be placed on the arm and record said movement data such as acceleration of the user.

Regarding claims 70, 113, 156, the movement sensor measures movement of the user's upper arm which also measures the acceleration of the user.

Regarding claims 71, 72, 114, 115, 157, the distance traveled is measured by sensors 20A-20C which can be the walking distance, the jogging distance or the running distance.

Regarding claims 74, 75, 76, as noted above, Burdea teaches the convention of associating a time/date stamp to movement data in order to record over time the performance of the user. The time/date stamp would necessarily be retrieved from a real-time clock in order to associate an accurate time and date stamp.

Regarding claims 77, the output indicator is configured to signal the occurrence of user-defined events such as pace of the user, rate of travel, distance traveled, etc. The microprocessor retrieves the time/date stamp from the real-time clock based on the occurrence of the user defined events such as pace of the user, rate of travel, distanced traveled, etc.

Regarding claims 78, 121, the microprocessor identifies the user-defined events based on interpretation of the movement data. The microprocessor has to interpret the acceleration data in order to identify the pace of the user, rate of travel, distance traveled, etc.

Regarding claims 79, 122, conventional memory includes nonvolatile memory such as battery backed RAM or Electrically Erasable Programmable Read Only Memory (EEPROM). Such is well-known to the artisan of ordinary skill. EEPROM is a well-known form of Read Only Memory used to store data that must be saved when power is removed. Therefore, the memory continues to store movement data in response to battery power being lost from said power source.

Regarding claims 80, 81, 123, 124, Gaudet teaches in column 8, lines 54-59:

Essentially, continuous-loop portion 101 continuously monitors the voltage across inputs 46 and 48 of micro-controller 40 to determine when negative and positive voltages differences (between inputs 46 and 48) in excess of predetermined

thresholds occur. These negative and positive voltage differences are indicative, respectively, of the foot of a user impacting with and leaving the ground.

In figure 5 of Gaudet, the output of accelerometer 32 is fed into the amplifier circuit 38 whose output is input to the microcontroller 40. Therefore the microcontroller has a continuous-loop algorithm 101 that continuously monitors the voltage across amplified signals from the accelerometer.

Regarding claims 82, 83, 84, 125, 126, 127, the output indicator displays the occurrence of user-defined events such as pace of the user, rate of travel, distance traveled, etc. which is based on movement data. The display also displays the time/date stamp from the real-time clock based on the occurrence of the user defined events such as pace of the user, rate of travel, distanced traveled, etc.

Regarding claim 89, Gaudet teaches the foot contact time/foot loft time generators 20 include a battery in column 6, lines 3-4. One of ordinary skill in the art having battery operated devices would require some form of output to let the user know when the batteries are about to die.

Regarding claims 94-97, Gaudet teaches in column 4, lines 43-46:

Workstation 14 can be coupled to hard copy device 18 for producing a hard copy of diagnostic information and rehabilitation instructions or rehabilitation progress charts. Remote workstation 20 can be coupled over network 22 to computer workstation 14. Remote workstation 20 can be used at a medical specialist location for receiving diagnostic information and communicating rehabilitation instructions to computer workstation 14.

Gaudet teaches producing hard copies of diagnostic information and rehabilitation instructions or rehabilitation progress charts. The diagnostic information and rehabilitation progress charts are reports of the physical activity. Progress charts are history reports. Progress

charts would necessarily include dates and times in order to compare past performances to present performance.

Regarding claim 98, Burdea teaches using a network 22 to communicate with a remote computer 20. A well-known means to communicate with a remote computer is a wired connection such as Ethernet using a download device e.g., a network interface card.

Regarding claim 99, wireless connection between computers is also obvious and well-known means to communicate between computers. Such would have been an obvious provision.

Claims 1, 13, 20 and 21, 30-158 are rejected under pre-AIA 35 U.S.C. 103(a) as being unpatentable over Vock et al. in view of Burdea et al.

Regarding claims 1, 13, 20, 21, 30-34, Vock teaches a self-contained device 10 comprising a movement sensor 18, a power source 22, a microprocessor 12, a user input 14, memory 13 and an output indicator 16 or display.

The movement sensor 18 measures data associated with unrestrained movement in any direction and generating signals indicative of said movement. As shown in figure 2 the portable, self-contained device 10 is mounted to the ski of the user. The user can manipulate the skis in an unrestrained movement in any direction. The sensor 18 generates signals indicative of the unrestrained movement.

The microprocessor 12 is connected to the movement sensor 18 and the power source 22 and is capable of receiving, interpreting, storing and responding to the movement data based on user-defined operational parameters. Vock teaches in column 8, lines 3-22:

Briefly, the invention shown in FIG. 1 operates as follows. The housing 24 is attached or mounted to a sporting device, such as a ski or mountain bike, such that

a user of the ski or mountain bike can access the system 10. During motion of the ski or mountain bike, the speed sensor 18 sends velocity information (over communication line 11a) to the microprocessor subsystem 12; while the loft sensor 20 sends loft or "air" time information (over communication line 11b) to the microprocessor subsystem 12. The speed information and loft time information are processed by the microprocessor subsystem 12 to quantify actual speed, e.g., in miles per hour, and actual loft time, e.g., in seconds. The actual speed and loft time are thereafter stored in internal memory 13 until, at least, the speed and time data are accessed by a user of the system 10. Upon access through the user interface 14 (communicating with the microprocessor subsystem 12 via communication line 11c), a user of the system 10 can command the display of the speed and loft time data (sent across communication line 11d) on the display 16 in order to evaluate his or her performance in the sporting activity.

The user, through the user interface 14, commands the microprocessor 12 to display the speed and loft time data on the display 16 in order to evaluate his or her performance in the sporting activity.

Vock also teaches a clock element in column 3, lines 17-21:

Preferably, the microprocessor subsystem of the invention includes a [clock] element, e.g., a 24-hour clock, for providing information convertible to an elapsed time. Accordingly, the subsystem can perform various calculations, e.g., dead time, on the data acquired by the apparatus for display to a user.

The clock of Vock appears to be used for calculating the various elapsed times however, providing a clock that can also associate dates as well as times to the movement data, the user can thereby collect data over days, weeks or months to track performance over time. Such would have been an obvious provision to one of ordinary skill in the art as exemplified by Burdea.

Burdea is cited to teach the convention of storing data for statistical purposes by including a time stamp associated with the data thereby providing historical progress, see column 6, lines 30-33. Any conventional means to tag a date and time stamp to the movement data for providing statistical information over time would have been obvious to one of ordinary skill. A real-time clock is a well-known example of a means to provide a date and time stamp. It would

have been obvious to one of ordinary skill in the art to modify Vock to include a time/date stamp as taught by Burdea such as real-time clock in order to track the movement data over time.

Vock teaches many different types of speed and loft sensors for acquiring velocity and loft or “air” time. In one embodiment of column 21 the speed sensor is pressure based. In this embodiment the speed sensor of Vock measures the angle and velocity of the movement. In column 21, lines 47-59:

Pressure sensors according to the invention convert air pressure to an analog voltage. When mounted to a snowboard 220, such as shown in FIGS. 15 and 15A, the pressure sensor 221 is used to determine the altitude of the snowboarder. This voltage is read by the microprocessor subsystem (e.g., the subsystem 12 of FIG. 1) at a fixed rate and differentiated to determine rate of descent or speed in the vertical direction. This may be converted to speed along the path by knowing the grade or angle of descent. Angle of descent is known by predetermining the geometry of the ski path or by the addition of an inclinometer 222 which gives a voltage dependent upon the angle, with respect to vertical, of the platform. The inclinometer 222 measures zero when the ski is traveling along a level path and the pressure sensor is showing a constant pressure. When the ski moves downhill, for example, the inclinometer 222 measures the angle of descent and the pressure sensor measures ever increasing pressure. Since the angle of descent is known, as is the rate of descent, the true speed is determined and displayed.

Vock teaches the speed sensor includes a pressure sensor 221 to determine the altitude of the user and inclinometer 222 gives a voltage dependent upon the angle with respect to vertical. The pressure sensor 221 determines the speed of vertical descent and the inclinometer 222 determines the angle. Since the angle of descent is known, and the rate of descent is known, the true speed is determined and displayed.

Claim 13, recites, in addition to the limitations of claim 1, an input/output port, a computer capable of interpreting and reporting the movement data based on operational parameters, and a download device connected to the movement measuring device and the

computer for transmitting the movement data and operational parameters between the movement measuring device and the computer for analysis, reporting and operation purposes.

Burdea shows in figure 1, network 22 is capable of transmitting the movement data and operational parameters between the movement measuring device 14 and the remote computer 20. The remote computer 20 is used for receiving diagnostic information and communicating rehabilitation instructions to the movement measuring device. Burdea column 4, lines 46-50:

Remote workstation 20 can be coupled over network 22 to computer workstation 14. Remote workstation 20 can be used at a medical specialist location for receiving diagnostic information and communicating rehabilitation instructions to computer workstation 14.

Broadly, the network 22 is the input/output port and the network interface card is the download device electronically connected to the movement measuring device and a remote computer for transmitting and receiving information.

It would have been obvious to one of ordinary skill in the art to further modify Vock to use the input/output port of the network 22, and the network card as a download device and remote computer as taught by Burdea for communicating movement data and operational parameters with a person for analysis.

Regarding claim 20, Vock teaches attaching a portable, self-contained movement measuring device 10 to the body part of the skis for measuring unrestrained movement in any direction. The sensors 221 and 222 measure data associated with the physical movement. The processor 12 interprets the physical movement data based on user-defined operational parameters and with the real-time clock, as taught by Burdea above, storing the data in memory 13 for storing historical data for a person to analyze.

Regarding claim 21, Vock teaches using pressure sensors 221 to determine speed and inclinometers 222 to determine the angle. The angle data would be taken along two orthogonal axes i.e., horizontal and vertical.

Regarding claims 33, 34, the microprocessor interprets the movement data based on the user-defined operational parameters to identify at least one user-defined event and retrieve the time stamp.

Regarding claims 35, 79, 122, 132, conventional memory includes nonvolatile memory such as battery backed RAM or Electrically Erasable Programmable Read Only Memory (EEPROM). Such is well-known to the artisan of ordinary skill. EEPROM is a well-known form of Read Only Memory used to store data that must be saved when power is removed. Therefore, the memory continues to store movement data in response to battery power being lost from said power source.

Regarding claims 36, 37, 80, 81, Vock teaches in column 26, lines 20-23:

The meters 600 start transmitting data at the starting gate 610 and continue to give data to the base 608 during the whole run on the slope 612.

The meters 600 continue to transmit movement data from the starting gate during the whole run on the slope. If the meters 600 continue to transmit movement data, then the microprocessor continuously interprets the movement data received from the movement sensor.

Regarding claims 38, 82, meters 600 include an output indicator display 630 for displaying information based on the movement data.

Regarding claims 39, 40, 83, 84, the same display 630 would display at least one time stamp associated with the movement data. As set forth in claim 1, Burdea teaches including a time/date stamp for each piece of movement data.

Regarding claims 41, 85, Vock teaches in column 9, lines 30-33:

A user presses the start/stop button 58 at the start of activity--such as at the start of skiing down a slope or biking down a trail--and presses the button 58 at the completion of activity to cease the acquisition of data

The threshold of the movement data is met when the user stops the acquisition of data. That is the limit of data collected. The output indicator displays the information such as speed and loft time.

Vock also teaches in column 9, lines 35-37:

A user pressed the display-operate button 60 to activate the display 52 so that a user can view recorded information from the sporting activity on the display 52.

The output indicator displays information indicating that a threshold is met based on the movement data such as peak speed and peak loft time.

Regarding claims 42, 86, Vock in column 2, line 66 to column 3, line 3, “a user interface for providing external inputs to the apparatus, including one or more of the following: a start/stop button for selectively starting and stopping the acquisition of data by the apparatus”. The threshold is met when the user stops the acquisition of data. That is the threshold of data collected. The output indicator displays the information such as speed and loft time.

Regarding claims 43, 44, 87, 88, memory stores the information indicating the threshold is met including the time/date stamp.

Regarding claims 45, 89, one of ordinary skill in the art having devices that include batteries would require some form of output to let the user know when the batteries are about to die.

Regarding claims 46, 90, the output indicator can include LCD and LED displays, see Vock, column 2, lines 30-31.

Regarding claims 47, 91, the movement data stored in memory is configured to be downloaded to a computer.

Regarding claims 48, 92, as noted above, Burdea teaches remote workstation 20 can be coupled over network 22 to computer workstation 14. Obviously, computer workstation 14 has software configured to communicate with external software in the remote workstation 20 wherein the external software is configured to present the downloaded movement data to the user in the display. It would have been obvious to download the physical activity from the local microprocessor to an external computer over a network as taught by Burdea in order to have the information saved at a different location so the information can be analyzed and processed for improving the user's performance.

Regarding claim 49, the external software is configured to run on the external computer.

Regarding claims 50, 93, the downloaded movement data is analyzed using the external software. The information on the remote workstation can be analyzed by the user.

Regarding claims 51, 94, 136, 137, 138, 139, 140, the external software is configured to interpret the movement data and produce at least one report. The purpose of the external computer is to analyze the data and to communicate new instructions for the user to the local workstation 14. Producing reports on the movement data including historical data would be obvious to one of ordinary skill in the art in order to develop new instructions for the user. Burdea teaches, column 4, lines 43-50, the workstation 14 is coupled to hard copy device 18 for producing a hard copy of diagnostic information including rehabilitation progress charts. The external computer would be better adapted to generate reports. Such would have been an obvious provision in Vock.

Regarding claims 52, 95, 140, the external software is configured to interpret the movement data and produce at least one history report. The purpose of the external computer is to analyze the historical data. Producing reports on the movement data including historical data would be obvious to one of ordinary skill in the art in order to develop new instructions for the user.

Regarding claims 53, 96, the history report obviously includes dates and time of the movement data. It is important to include the dates and times in order to develop a new training program for the user.

Regarding claims 54, 97, the external software is configured to allow the user to program additional reports and histories with respect to the movement data.

Regarding claims 55, 98, 141, the movement data is configured to be downloaded to the computer via a wired connection. Network 22 is a wired connection.

Regarding claims 56, 99, 142, wireless connections are old and well known and an obvious equivalent means of communicating information over air waves.

Regarding claim 57, 100, 131, 143, the microprocessor records the time and date of the threshold being met. The microprocessor records the time and date for all movement data.

Regarding claim 58, 101, 144, the output indicator provides a visual indicator to the user regarding the threshold being met. Displays 16, 52, 162, 630 would display the speed of the user, distance traveled, etc. based on the microprocessor determining that the threshold is met.

Regarding claim 59, 102, 145, 149, the threshold is met when the user stops the acquisition of data. This sets the threshold for the amount of movement data to collect.

Regarding claim 60, 103, 106, 130, 146, memory stores a plurality of thresholds respectively corresponding to a plurality of notifications such as peak speed and peak loft time. Each time the user sets the threshold, a new set of notifications would be stored along with the thresholds.

Regarding claims 61, 104, 147, each time the user sets the threshold, the plurality of user-defined events would be displayed with a corresponding notification.

Regarding claims 62, 105, 148, the microprocessor interprets the movement data to determine whether a threshold is met such as peak speed or peak loft time. The microprocessor compares one movement data for the speed and compares it to the next movement data for the speed to determine which is the maximum or peak speed value. It continues to compare the current peak speed to the next movement data speed value until all of the movement data values has been compared. The threshold has been met when the microprocessor has determined the threshold peak speed or loft time from all of the movement data during the physical activity. The output indicator signals the occurrence of at least one of the user-defined events such as peak speed and peak loft based on the microprocessor determining that the maximum threshold is met.

Regarding claims 63, 129, 149, at least one of the plurality of thresholds is set by the user when they stop collecting the movement data. This sets the threshold for the amount of movement data to collect.

Regarding claims 64, 150, the plurality of thresholds are different from each other because they are collected at different times or different physical activities plus.

Regarding claims 65, 107, 108, 151, the plurality of notifications have different visual indicators because one measures speed and another measures loft time.

Regarding claims 66, 109, 152, the prior art has already established the convention of using visual indicators to display different results. Using a blinking indicator is old and well known and an obvious provision in the art of displaying information on a display screen in order to highlight one particular piece of data. Where the general conditions of a claim are disclosed in the prior art, it is not inventive to discover the optimum or workable ranges by routine experimentation. *In re Swain et al.*, 33 CCPA (Patents) 1250, 156 F.2d 239, 70 USPQ 412; *Minnesota Mining and Mfg. Co. v. Coe*, 69 App. D.C. 217, 99 F.2d 986, 38 USPQ 213; *Allen et al. v. Coe*, 77 App. D.C. 324, 135 F.2d 11, 57 USPQ 136. Providing blinking lights to highlight a portion of the display is well within the realm of the artisan of ordinary skill in the art of displaying information on a display screen.

Regarding claims 67, 68, 110, 111, the microprocessor interprets the movement data to determine whether a threshold is met such as peak speed or peak loft time. The microprocessor compares one movement data for the speed and compares it to the speed of the next movement data to determine which is the maximum or peak speed value. It continues to compare the current peak speed to the next movement data speed value until all of the movement data values has been compared. The threshold has been met when the microprocessor has determined the threshold peak speed or loft time from all of the movement data during the physical activity. The output indicator signals the occurrence of at least one of the user-defined events such as peak speed and peak loft based on the microprocessor determining that the maximum threshold is met.

Regarding claims 69, 112, 155, Vock teaches in column 19, line 15 that the device can be mounted to the user. Therefore, the device is capable of being placed on the user's arm and still be able to perform the function of recording the speed of the user, for example.

Regarding claims 70, 72, 113, 155, with the device attached to the user's arm the sensor measures movement of the user's arm which will measure the speed of the user.

Regarding claims 71, 72, 114, 115, 157, the movement sensor measures distance as well as speed. Vock teaches in column 20, lines 6-9, "one accelerometer can be used to detect speed; which is the integral of the acceleration over time. Further, a double integration over the same period provides distance". Therefore, the movement sensor of Vock would also measure walking distance if one so chooses.

Regarding claims 73, 116-121, 123, 124, 134-138, 140, 158, as noted above, Burdea teaches including a time stamp for associating the time/date stamp with the movement data and user-defined events for providing a time history of updates of the user performance for storing in memory. The microprocessor also stores in memory the date associated with the time stamp. The microprocessor also continuously checks movement data received from the movement sensor after the user presses the start button which is a user-defined operational parameter. The output indicator displays information based on the movement data indicating that a threshold has been met such as the peak speed data or peak "air" time. The movement data stored in memory is configured to be downloaded to an external computer. Any data stored in memory can be downloaded to an external computer. The device comprises software configured to communicate with external software configured to run on a computer and present the downloaded movement data. The purpose of the external computer is to analyze the historical data. Producing reports on the movement data including historical data would be obvious to one of ordinary skill in the art in order to develop new instructions for the user. The memory stores a plurality of thresholds on different days respectively corresponding to a plurality of notifications

such as peak speed and peak “air” time including the time/date of the movement data. The sensor can be mounted on the arm of the user and measures the movement of the user’s arm to determine the speed of the user. A sensor on the arm of the user would be able to measure the speed of the user.

Regarding claims 74-78, 125-128, 139, as noted above, Burdea teaches including a time stamp for associating the time/date stamp with the movement data so as to provide a time history of the user performance to be stored in memory. The output indicator or displays 16, 52, 162, 630 are configured to signal the occurrence of user-defined events such as peak speed and peak loft time which is based on movement data. The microprocessor retrieves the time/date stamp from the real-time clock based on the user-defined events.

Regarding claim 133, the physical movement data stored in memory is the interpreted physical movement data such as speed and loft time, and the stored physical movement data is configured to be downloaded to a computer as taught by Burdea.

Regarding claim 153, Vock teaches signaling the occurrence of a user-defined event such as peak speed or peak loft time which is based on the threshold being met.

Regarding claim 154, Vock teaches using the output indicator to signal the occurrence of a user-defined event such as peak speed and peak loft time which is based on determining of whether the threshold is met. The physical movement data is compared to the peak speed or peak loft time which when all of the movement data has been processed, the threshold for the peak speed and peak loft time has been met.

Regarding claim 156, Vock teaches measuring the movement data to determine the speed or loft time of the portable, self-contained movement measuring device.

Amendment in Reexamination Proceedings

In any reexamination proceeding under this chapter, the patent owner will be permitted to propose any amendment to his patent and a new claim or claims thereto, in order to distinguish the invention as claimed from the prior art cited under the provisions of section 301 of this title, or in response to a decision adverse to the patentability of a claim of a patent. See 35 U.S.C. 305. **For this reason, patent owner is notified that *any* amendment to a claim not involved in the reexamination proceeding may not be entered, and if entered, will bring that claim into the reexamination proceeding.** See 37 CFR 1.104.

Patent owner is also notified that any proposed amendment to the specification and/or claims in this reexamination proceeding must comply with 37 C.F.R. 1.530(d)-(j), must be formally presented pursuant to 37 C.F.R. 1.52(a) and (b), and must contain any fees required by 37 C.F.R. 1.20(c). See MPEP § 2250(IV) for examples to assist in the preparation of proper proposed amendments in reexamination proceedings. Also, in accordance with 37 CFR 1.530(e), each claim amendment must be accompanied by an explanation of the support in the disclosure of the patent for the amendment (i.e., support for the changes made in the claim(s), support for any insertions and deletions). The failure to submit an explanation will generally result in a noncompliant response since the failure to set forth the support in the disclosure goes to the merits of the case (see MPEP § 2266.01). Such an amendment submitted after final rejection will not be entered.

Extensions of Time

Extensions of time under 37 C.F.R. 1.136(a) will not be permitted in these proceedings because the provisions of 37 C.F.R. 1.136 apply only to “an applicant” and not to parties in a reexamination proceedings. Additionally, 35 U.S.C. 305 requires that *ex parte* reexamination proceedings “will be conducted with special dispatch” (37 C.F.R. 1.550(a)). Extensions of time in *ex parte* reexamination proceedings are provided for in 37 C.F.R. 1.550(c).

Notification of Concurrent Proceedings

The patent owner is reminded of the continuing responsibility under 37 C.F.R. 1.565(a) to apprise the Office of any litigation activity, or other prior or concurrent proceeding, involving the patent throughout the course of this reexamination proceeding. Likewise, if present, the third party requester is also reminded of the ability to similarly apprise the Office of any such activity or proceeding throughout the course of this reexamination proceeding. See MPEP §§ 2207, 2282 and 2286.

Service of Papers

After filing of a request for *ex parte* reexamination by a third party requester, any document filed by either the patent owner or the third party requester must be served on the other party (or parties where two or more third party requester proceedings are merged) in the reexamination proceeding in the manner provided in 37 CFR 1.248. The document must reflect service or the document may be refused consideration by the Office. See 37 CFR 1.550(f).

Conclusion

All correspondence relating to this *ex parte* reexamination proceeding should be directed:

By EFS: Registered users may submit via the electronic filing system EFS-Web, at <https://efs.uspto.gov/efile/myportal/efs-registered>.

By Mail to: Mail Stop *Ex Parte* Reexam
Central Reexamination Unit
Commissioner for Patents
United States Patent & Trademark Office
P.O. Box 1450 Alexandria, VA 22313-1450

By FAX to: (571) 273-9900
Central Reexamination Unit

By hand: Customer Service Window
Randolph Building
401 Dulany Street
Alexandria, VA 22314

For EFS-Web transmissions, 37 CFR 1.8(a)(1)(i) (C) and (ii) states that correspondence (except for a request for reexamination and a corrected or replacement request for reexamination) will be considered timely filed if (a) it is transmitted via the Office's electronic filing system in accordance with 37 CFR 1.6(a)(4), and (b) includes a certificate of transmission for each piece of correspondence stating the date of transmission, which is prior to the expiration of the set period of time in the Office action.

Any inquiry concerning this communication or earlier communications from the Examiner, or as to the status of this proceeding, should be directed to the Central Reexamination Unit at telephone number (571) 272-7705.

Telephone Number for reexamination inquiries:

Reexamination and Amendment Practice	(571) 272-7703
Central Reexam Unit (CRU)	(571) 272-7705
Reexamination Facsimile Transmission No.	(571) 273-9900

/Danton DeMille/
Patent Reexamination Specialist
Central Reexamination Unit 3993
(571) 272-4974
12 August 2014

Conferee: /RMF/

Conferee: /EDL/

Notice of References Cited	Application/Control No. 90/013,201	Applicant(s)/Patent Under Reexamination 6059576	
	Examiner DANTON DE MILLE	Art Unit 3993	Page 1 of 1

U.S. PATENT DOCUMENTS

*		Document Number Country Code-Number-Kind Code	Date MM-YYYY	Name	Classification
*	A	US-5,429,140	07-1995	Burdea et al.	600/587
	B	US-			
	C	US-			
	D	US-			
	E	US-			
	F	US-			
	G	US-			
	H	US-			
	I	US-			
	J	US-			
	K	US-			
	L	US-			
	M	US-			

FOREIGN PATENT DOCUMENTS

*		Document Number Country Code-Number-Kind Code	Date MM-YYYY	Country	Name	Classification
	N					
	O					
	P					
	Q					
	R					
	S					
	T					

NON-PATENT DOCUMENTS

*		Include as applicable: Author, Title Date, Publisher, Edition or Volume, Pertinent Pages)
	U	
	V	
	W	
	X	

*A copy of this reference is not being furnished with this Office action. (See MPEP § 707.05(a).)
Dates in MM-YYYY format are publication dates. Classifications may be US or foreign.

INFORMATION DISCLOSURE STATEMENT BY APPLICANT (Not for submission under 37 CFR 1.99)	Application Number	Not Yet Assigned
	Confirmation Number	Not Yet Assigned
	Filing Date	April 4, 2014
	First Named Inventor	Theodore L. Brann
	Art Unit	Not Yet Assigned
	Examiner Name	Not Yet Assigned
Attorney Docket Number		A209779

U.S. PATENTS						
Examiner Initials	Cite No	Patent Number	Kind Code	Issue Date	Name of Patentee or Applicant of cited Document	Pages, Columns, Lines, Where Relevant Passages or Relevant Figures Appear
	1.	5636146		1997-06-03	Flentov et al.	
	2.	6018705		2000-01-25	Gaudet et al.	
	3.	6266623	B1	2001-07-24	Vock et al.	

U.S. PATENT APPLICATION PUBLICATIONS						
Examiner Initials	Cite No	Publication Number	Kind Code	Publication Date	Name of Patentee or Applicant of cited Document	Pages, Columns, Lines, Where Relevant Passages or Relevant Figures Appear

FOREIGN PATENT DOCUMENTS								
Examiner Initials	Cite No	Foreign Document Number	Country Code	Kind Code	Publication Date	Name of Patentee or Applicant of cited Document	Pages, Columns, Lines, Where Relevant Passages or Relevant Figures Appear	T

NON-PATENT LITERATURE DOCUMENTS			
Examiner Initials	Cite No	Include name of the author (in CAPITAL LETTERS), title of the article (when appropriate), title of the item (book, magazine, journal, serial, symposium, catalog, etc.), date, page(s), volume-issue number(s), publisher, city, and/or country where published.	T

EXAMINER SIGNATURE			
Examiner Signature	/Danton DeMille/ (05/20/2014)		Date Considered

ALL REFERENCES CONSIDERED EXCEPT WHERE LINED THROUGH. /DD/

*EXAMINER: Initial if reference considered, whether or not citation is in conformance with MPEP 609. Draw line through a citation if not in conformance and not considered. Include copy of this form with next communication to applicant.

1 See Kind Codes of USPTO Patent Documents at www.USPTO.GOV or MPEP 901.04. 2 Enter office that issued the document, by the two-letter code (WIPO Standard ST.3). 3 For Japanese patent documents, the indication of the year of the reign of the Emperor must precede the serial number of the patent document. 4 Kind of document by the appropriate symbols as indicated on the document under WIPO Standard ST.16 if possible. 5 Applicant is to place a check mark here if English language translation is attached.



UNITED STATES PATENT AND TRADEMARK OFFICE

UNITED STATES DEPARTMENT OF COMMERCE
United States Patent and Trademark Office
Address: COMMISSIONER FOR PATENTS
P.O. Box 1450
Alexandria, Virginia 22313-1450
www.uspto.gov

APPLICATION NO.	FILING DATE	FIRST NAMED INVENTOR	ATTORNEY DOCKET NO.	CONFIRMATION NO.
90/013,201	04/04/2014	6059576	A209779	9930
23373	7590	06/03/2014	EXAMINER	
SUGHRUE MION, PLLC 2100 PENNSYLVANIA AVENUE, N.W. SUITE 800 WASHINGTON, DC 20037			DEMILLE, DANTON D	
			ART UNIT	PAPER NUMBER
			3993	
			MAIL DATE	DELIVERY MODE
			06/03/2014	PAPER

Please find below and/or attached an Office communication concerning this application or proceeding.

The time period for reply, if any, is set in the attached communication.

Order Granting / Denying Request For Ex Parte Reexamination	Control No. 90/013,201	Patent Under Reexamination 6059576
	Examiner DANTON DE MILLE	Art Unit 3993

--The MAILING DATE of this communication appears on the cover sheet with the correspondence address--

The request for *ex parte* reexamination filed 04 April 2014 has been considered and a determination has been made. An identification of the claims, the references relied upon, and the rationale supporting the determination are attached.

Attachments: a) PTO-892, b) PTO/SB/08, c) Other: IDS

1. The request for *ex parte* reexamination is GRANTED.

RESPONSE TIMES ARE SET AS FOLLOWS:

For Patent Owner's Statement (Optional): TWO MONTHS from the mailing date of this communication (37 CFR 1.530 (b)). **EXTENSIONS OF TIME ARE GOVERNED BY 37 CFR 1.550(c).**

For Requester's Reply (optional): TWO MONTHS from the **date of service** of any timely filed Patent Owner's Statement (37 CFR 1.535). **NO EXTENSION OF THIS TIME PERIOD IS PERMITTED.** If Patent Owner does not file a timely statement under 37 CFR 1.530(b), then no reply by requester is permitted.

2. The request for *ex parte* reexamination is DENIED.

This decision is not appealable (35 U.S.C. 303(c)). Requester may seek review by petition to the Commissioner under 37 CFR 1.181 within ONE MONTH from the mailing date of this communication (37 CFR 1.515(c)). **EXTENSION OF TIME TO FILE SUCH A PETITION UNDER 37 CFR 1.181 ARE AVAILABLE ONLY BY PETITION TO SUSPEND OR WAIVE THE REGULATIONS UNDER 37 CFR 1.183.**

In due course, a refund under 37 CFR 1.26 (c) will be made to requester:

- a) by Treasury check or,
b) by credit to Deposit Account No. _____, or
c) by credit to a credit card account, unless otherwise notified (35 U.S.C. 303(c)).

/D. D./ Primary Examiner, Art Unit 3993		
--	--	--

cc:Requester (if third party requester)

DECISION GRANTING *EX PARTE* REEXAMINATION

A substantial new Question (SNQ) of patentability affecting claims 1, 13, 20 and 21 of US Patent No. 6,059,576 (hereinafter “the ‘576 patent”) is raised by the patent owner for *ex parte* reexamination.

Prosecution History for the ‘576 Patent

The ‘576 patent issued from Application Serial No. 08/976,228 (“the ‘228 Application”), which was filed on 21 November 1997. A first Office action rejection was made applying Stark (U.S. Pat. No. 5,052,375) alone and with secondary references. An amendment was filed which cancelled claim 8 and further defined a “port” to an “input/output” port. The rejection was made final. After an interview, the patent owner filed a Continued Prosecution Application with amendments to the first two independent claims that further limited the device to a “portable, self-contained” device for “monitoring” movement where the movement sensor is capable of measuring “unrestrained” movement “in any direction”. These claims were also amended to include a wherein clause “wherein said movement sensor measures the angle and velocity of said movement”. The third independent claim was amended to further define the method of attaching a “portable, self-contained” movement measuring device “for measuring unrestrained movement in any direction”. The following Office action was an allowance.

On 06 December 1999, the Examiner issued a Notice of Allowability which included reasons for allowance as follows:

None of the prior art of record shows the combination of the structure of the claimed portable self-contained device and method for monitoring physical movement of body parts during physical activity comprising the movement sensor

capable of measuring data associated with unrestrained movement in any direction and generating signals indicative of the movement, which are the angle and velocity of the movement, the power source, the microprocessor capable of receiving, interpreting, storing and responding to the movement data based on the user-defined operational parameters, at least one user input connected to the microprocessor for controlling the operation of the portable self-contained device, the real-time clock connected to the microprocessor, memory for storing the movement data, and the output indicator connected to the microprocessor for signaling the occurrence of user-defined events, or the combination of the structure of the claimed system to aid in training and safety during physical activity comprising the portable self-contained movement measuring device which comprising the movement sensor capable of measuring data associated with unrestrained movement in any direction and generating signals indicative of the movement, which are the angle and velocity of the movement, the power source, the microprocessor capable of receiving, interpreting, storing and responding to the movement data based on the user-defined operational parameters, at least one user input connected to the microprocessor for controlling the operation of the portable self-contained device, the real-time clock connected to the microprocessor, memory for storing the movement data, at least one input/output port connected to the microprocessor for downloading the data and uploading the operational parameters and the output indicator connected to the microprocessor, the computer running a program capable of interpreting and reporting the movement data based on the operational parameters, and the download device electronically connecting to the movement measuring device and the computer for transmitting the movement data and operational parameters between the movement measuring device and the computer for analysis, reporting and operation purposes.

Discussion of Prior Art

Flentov et al. U.S. Patent No. 5,636,146, issued 03 June 1997. Flentov et al. was not considered during the previous examination. Flentov et al. is prior art under 35 USC § 102(e) filed 21 November 1994.
A detailed explanation regarding the applicability of Flentov et al. to the above identified claims of the '576 patent is provided in the Request on pages 41-44 and 50-63.

Gaudet U.S. Patent No. 6,018,705, issued 25 January 2000. Gaudet was not considered during the previous examination. Gaudet is prior art under 35 USC § 102(e) filed 02 October 1997.

A detailed explanation regarding the applicability of Gaudet to claims 1, 13 and 20 of the '576 patent is provided on pages 45-46 and 64-83.

Vock et al. U.S. Patent No. 6,266,623, issued 24 July 2001. Vock et al. was not considered during the previous examination. Vock et al. is prior art under 35 USC § 102(e) filed 02 June 1997.

A detailed explanation regarding the applicability of Vock et al. to claims 1, 13 and 20 of the '576 patent is provided on pages 47-48 and 84-98.

Substantial New Questions of Patentability Proposed by Patent Owner

The Patent Owner requested reexamination of claims 1, 13, 20 and 21 of the '576 patent based upon the following proposed rejections supported by alleged substantial new questions of patentability (SNQs):

1. Flentov raises a substantial new question of patentability for independent claims 1, 13 and 20.
2. Flentov raises a substantial new question of patentability for claim 21.
3. Gaudet raises a substantial new question of patentability for independent claims 1, 13 and 20.
4. Vock raises a substantial new question of patentability for independent claims 1, 13 and 20.

Analysis of proposed SNQs

Proposed SNQs 1 and 2: Flentov

It is agreed that Flentov teaches a portable, self-contained device 10 for monitoring movement of body parts during physical activity. Flentov discloses that "[t]he invention provides... [an] apparatus for determining the loft time of a moving vehicle off of a surface. A

loft sensor senses a first condition that is indicative of the vehicle leaving the surface, and further senses a second condition indicative of the vehicle returning to the surface", where the moving vehicle could be the user (human) (col. 3, lines 64-65 and col. 19, lines 12-16). The loft sensor is capable of measuring data associated with unrestrained movement in any direction because it is within housing 24 that is mounted on ski 26 as shown in figure 2. The user is able to move unrestrained in any direction on skis 26.

A power source or battery 22 is taught, along with a microprocessor 12, a user input 14, a 24-hour time clock, column 9, lines 29-34:

the microprocessor subsystem 12 of FIG. 1 preferably includes a clock element (readily known to those skilled in the art) for indicating processed time over a selectable period (the microprocessor subsystem 12 can in fact include a 24-hour clock element, much the way a digital wrist-watch includes 24-hour information)

The microprocessor subsystem 12 is capable of receiving sensory input, interpreting the information, storing the information in memory 13 and responding to the movement data by displaying the information on display 16 based on user-defined operations parameters between when "[a] user presses the start/stop button 58 at the start of activity – such as at the start of skiing down a slope or biking down a trail – and presses the button 58 at the completion of the activity to cease the acquisition of data", column 7, lines 38-41. Flentov teaches the system can include "pressure sensor 221 is used to determine the altitude of the snowboarder. This voltage is read by the microprocessor subsystem (e.g., the subsystem 12 of FIG. 1) at a fixed rate and differentiated to determine rate of descent or speed in the vertical direction. This may be converted to speed along the path by knowing the grade or angle of descent. Angle of descent is known by predetermining the geometry of the ski path or by the addition of a inclinometer 222 which gives a voltage dependent upon the angle, with respect to vertical, of the platform",

column 19, lines 30-39. Therefore the Flentov system teaches measuring the angle and velocity of the movement of the portable, self-contained device.

Therefore, Flentov appears to have teachings relevant to the limitations determined allowable in the prosecution of the '576 patent. Further, there is a substantial likelihood that a reasonable examiner would consider these teachings important in deciding whether or not claims 1, 13, 20 and 21 are patentable. Accordingly, Flentov raises an SNQ as to claims 1, 13, 20, which has not been decided in a previous examination of the '576 patent.

Proposed SNQ 3: Gaudet

It is agreed that Gaudet teaches a portable, self-contained “device for analyzing motion of a foot of a person relative to a surface, comprising an accelerometer supported in relation to the foot, the accelerometer being configured and arranged to provide an output signal indicative of motion of the foot during at least one footstep taken by the person” (col. 19, lines 41-46). The accelerometer is a motion sensor capable of measuring data associated with unrestrained movement in any direction. A “power source” is mentioned in column 12, lines 41-44. In the abstract the microprocessor is mentioned:

The output of the accelerometer is high-pass filtered, amplified, and fed to the input of a micro-controller, which monitors the signal for positive and negative signal spikes that are indicative, respectively, of the moment that the foot of the user leaves the ground and the moment that the foot impacts with the ground. By measuring time intervals between these positive and negative spikes, average ‘foot contact times’ and ‘foot loft times’ of the user may be calculated. To derive the pace of the user, the average foot contact time is multiplied by a first constant if it is less than 400 milli-seconds (ms) and is multiplied by a second constant if it is greater than 400 ms. This pace value may, in turn, be used to calculate the distance traveled by the user.

The microprocessor receives input from the accelerometer from each foot contact time/foot loft time generator and calculates the pace and distance traveled. The “timers” are used to measure the real time between positive and negative spikes to determine pace and distance.

In column 5, lines 7-18 Gaudet teaches an output indicator:

the system 72 includes a foot contact time/foot loft time generator 20 (which could correspond to either of foot contact time/foot loft time generators 20A and 20B in FIG. 1), a memory unit 54, a user interface 58, a display 56A, and an audio or vibrational indicator 56B. According to one embodiment, foot contact time/foot loft time generator 20 includes a micro-controller having virtually all circuitry, e.g., memory, timers and analog-to-digital (A/D) converters, on board, so that memory unit 54 need only be used to perform functions such as permanently storing data produced by foot contact time/foot loft time generator 20.

Gaudet teaches the “foot contact time/foot loft time generator 20 includes a micro-controller having virtually all circuitry, e.g., memory, timers... to perform functions such as permanently storing data produced by foot contact time/foot loft time generator 20”.

Regarding claim 13, Gaudet discloses that the computer and other system components "may be linked together, for example, via direct wiring or capacitive coupling, by using radio-frequency (RF) or infra-red (IR) transmitters/receivers, or by any other information transmission medium known to those skilled in the art." (col. 4, lines 17-21). As such, the disclosure of the possible use of a personal computer to process information from various components of the system (col. 4, lines 23-25) would appear to require the I/O port, as claimed. The personal computer would appear to require a download device to transfer information.

Therefore, Gaudet appears to have teachings relevant to the limitations determined allowable in the prosecution of the ‘576 patent. Further, there is a substantial likelihood that a reasonable examiner would consider these teachings important in deciding whether or not claims

1, 13 and 20 are patentable. Accordingly, Gaudet raises an SNQ as to claims 1, 13 and 20, which has not been decided in a previous examination of the '576 patent.

Proposed SNQ 4: Vock

As set forth in the request, Vock teaches a portable, self-contained device 10, 24 for monitoring movement of body parts during physical activity in column 1, lines 15-17:

The invention relates generally to the measurement of the loft time, power absorbed and speed of a vehicle relative to the ground.

The device include a movement sensor 18, 20 capable of measuring data associated with unrestrained movement in any direction and generating signals indicative of said movement,

Column 8, lines 4-11:

The housing 24 is attached or mounted to a sporting device, such as a ski or mountain bike, such that a user of the ski or mountain bike can access the system 10. During motion of the ski or mountain bike, the speed sensor 18 sends velocity information (over communication line 11a) to the microprocessor subsystem 12; while the loft sensor 20 sends loft or "air" time information (over communication line 11b) to the microprocessor subsystem 12. The speed information and loft time information are processed by the microprocessor subsystem 12 to quantify actual speed, e.g., in miles per hour, and actual loft time, e.g., in seconds.

The device includes a power source 22. A user interface 14 for controlling the operation of the device.

Vock teaches a real-time clock in column 11, lines 20-25:

the microprocessor subsystem 12 of FIG. 1 preferably includes a [clock] element (readily known to those skilled in the art) for indicating processed time over a selectable period (the microprocessor subsystem 12 can in fact include a 24-hour clock element, much the way a digital wrist-watch includes 24-hour information).

The clock element keeps real-time.

Vock teaches the invention includes memory in column 2, lines 37-43:

the invention includes memory for storing information representative of at least one of the following: (i) the first and second conditions, (ii) the loft time, (iii) a speed of the vehicle, (iv) successive records of loft time, (v) an average loft time, (vi) a total loft time, (vii) a dead time, (viii) a real activity time, and (ix) a numerical ranking of successive records.

Vock also teaches an output indicator 16 for displaying selective information including one or more of successive records of speed information, distance traveled and an indication of a number of a successive record relative to all successive records.

The system also measures the angle and velocity or speed of movement in column 21, lines 46-59 (emphasis added):

Pressure sensors according to the invention convert air pressure to an analog voltage. When mounted to a snowboard 220, such as shown in FIGS. 15 and 15A, the pressure sensor 221 is used to determine the altitude of the snowboarder. This voltage is read by the microprocessor subsystem (e.g., the subsystem 12 of FIG. 1) at a fixed rate and differentiated to determine rate of descent or speed in the vertical direction. This may be converted to **speed** along the path by knowing the grade or **angle of descent**. **Angle of descent** is known by predetermining the geometry of the ski path.

Vock teaches an RF transmitter and receiver that is used for transferring data to and from the remote base 608.

Therefore, Vock appears to have teachings relevant to the limitations determined allowable in the prosecution of the '576 patent. Further, there is a substantial likelihood that a reasonable examiner would consider these teachings important in deciding whether or not claims 1, 13 and 20 are patentable. Accordingly, Vock raises an SNQ as to claims 1, 13 and 20, which has not been decided in a previous examination of the '576 patent.

Extensions of Time

Extensions of time under 37 C.F.R. 1.136(a) will not be permitted in these proceedings because the provisions of 37 C.F.R. 1.136 apply only to "an applicant" and not to

parties in a reexamination proceedings. Additionally, 35 U.S.C. 305 requires that *ex parte* reexamination proceedings “will be conducted with special dispatch” (37 C.F.R. 1.550(a)). Extensions of time in *ex parte* reexamination proceedings are provided for in 37 C.F.R. 1.550(c).

Notification of Concurrent Proceedings

The patent owner is reminded of the continuing responsibility under 37 C.F.R. 1.565(a) to apprise the Office of any litigation activity, or other prior or concurrent proceeding, involving the patent throughout the course of this reexamination proceeding. Likewise, if present, the third party requester is also reminded of the ability to similarly apprise the Office of any such activity or proceeding throughout the course of this reexamination proceeding. See MPEP §§ 2207, 2282 and 2286.

Service of Papers

After filing of a request for *ex parte* reexamination by a third party requester, any document filed by either the patent owner or the third party requester must be served on the other party (or parties where two or more third party requester proceedings are merged) in the reexamination proceeding in the manner provided in 37 CFR 1.248. The document must reflect service or the document may be refused consideration by the Office. See 37 CFR 1.550(f).

Conclusion

All correspondence relating to this *ex parte* reexamination proceeding should be directed:

By EFS: Registered users may submit via the electronic filing system EFS-Web, at <https://efs.uspto.gov/efile/myportal/efs-registered>.

By Mail to: Mail Stop *Ex Parte* Reexam
Central Reexamination Unit
Commissioner for Patents
United States Patent & Trademark Office
P.O. Box 1450 Alexandria, VA 22313-1450

By FAX to: (571) 273-9900
Central Reexamination Unit

By hand: Customer Service Window
Randolph Building
401 Dulany Street
Alexandria, VA 22314

For EFS-Web transmissions, 37 CFR 1.8(a)(1)(i) (C) and (ii) states that correspondence (except for a request for reexamination and a corrected or replacement request for reexamination) will be considered timely filed if (a) it is transmitted via the Office's electronic filing system in accordance with 37 CFR 1.6(a)(4), and (b) includes a certificate of transmission for each piece of correspondence stating the date of transmission, which is prior to the expiration of the set period of time in the Office action.

Any inquiry concerning this communication or earlier communications from the Examiner, or as to the status of this proceeding, should be directed to the Central Reexamination Unit at telephone number (571) 272-7705.

Telephone Number for reexamination inquiries:

Reexamination and Amendment Practice	(571) 272-7703
Central Reexam Unit (CRU)	(571) 272-7705
Reexamination Facsimile Transmission No.	(571) 273-9900

/Danton DeMille/
Patent Reexamination Specialist
Central Reexamination Unit 3993
(571) 272-4974
2 June 2014

Conferee: /JGF/

Conferee:/EDL/

Reexamination 	Application/Control No.	Applicant(s)/Patent Under Reexamination
	90/013,201	6059576
	Certificate Date	Certificate Number

Requester	Correspondence Address:	<input checked="" type="checkbox"/> Patent Owner	<input type="checkbox"/> Third Party
<p>SUGHRUE MION, PLLC 2100 PENNSYLVANIA AVENUE, N.W. SUITE 800 WASHINGTON, DC 20037</p>			

LITIGATION REVIEW <input checked="" type="checkbox"/>	/DDD/ (examiner initials)	5/9/14 (date)
Case Name		Director Initials
NONE		

COPENDING OFFICE PROCEEDINGS	
TYPE OF PROCEEDING	NUMBER
1. NONE	
2.	
3.	
4.	

INFORMATION DISCLOSURE STATEMENT BY APPLICANT (Not for submission under 37 CFR 1.99)	Application Number	Not Yet Assigned
	Confirmation Number	Not Yet Assigned
	Filing Date	April 4, 2014
	First Named Inventor	Theodore L. Brann
	Art Unit	Not Yet Assigned
	Examiner Name	Not Yet Assigned
	Attorney Docket Number	A209779

U.S. PATENTS						
Examiner Initials	Cite No	Patent Number	Kind Code	Issue Date	Name of Patentee or Applicant of cited Document	Pages, Columns, Lines, Where Relevant Passages or Relevant Figures Appear
	1.	5636146		1997-06-03	Flentov et al.	
	2.	6018705		2000-01-25	Gaudet et al.	
	3.	6266623	B1	2001-07-24	Vock et al.	

U.S. PATENT APPLICATION PUBLICATIONS						
Examiner Initials	Cite No	Publication Number	Kind Code	Publication Date	Name of Patentee or Applicant of cited Document	Pages, Columns, Lines, Where Relevant Passages or Relevant Figures Appear

FOREIGN PATENT DOCUMENTS								
Examiner Initials	Cite No	Foreign Document Number	Country Code	Kind Code	Publication Date	Name of Patentee or Applicant of cited Document	Pages, Columns, Lines, Where Relevant Passages or Relevant Figures Appear	T

NON-PATENT LITERATURE DOCUMENTS			
Examiner Initials	Cite No	Include name of the author (in CAPITAL LETTERS), title of the article (when appropriate), title of the item (book, magazine, journal, serial, symposium, catalog, etc.), date, page(s), volume-issue number(s), publisher, city, and/or country where published.	T

EXAMINER SIGNATURE			
Examiner Signature	/Danton DeMille/ (05/20/2014)		Date Considered

ALL REFERENCES CONSIDERED EXCEPT WHERE LINED THROUGH. /DD/

*EXAMINER: Initial if reference considered, whether or not citation is in conformance with MPEP 609. Draw line through a citation if not in conformance and not considered. Include copy of this form with next communication to applicant.

1 See Kind Codes of USPTO Patent Documents at www.USPTO.GOV or MPEP 901.04. 2 Enter office that issued the document, by the two-letter code (WIPO Standard ST.3). 3 For Japanese patent documents, the indication of the year of the reign of the Emperor must precede the serial number of the patent document. 4 Kind of document by the appropriate symbols as indicated on the document under WIPO Standard ST.16 if possible. 5 Applicant is to place a check mark here if English language translation is attached.



UNITED STATES PATENT AND TRADEMARK OFFICE

UNITED STATES DEPARTMENT OF COMMERCE
United States Patent and Trademark Office
Address: COMMISSIONER FOR PATENTS
P.O. Box 1450
Alexandria, Virginia 22313-1450
www.uspto.gov

APPLICATION NO.	FILING DATE	FIRST NAMED INVENTOR	ATTORNEY DOCKET NO.	CONFIRMATION NO.
-----------------	-------------	----------------------	---------------------	------------------

90/013,201	04/04/2014	6059576	A209779	9930
------------	------------	---------	---------	------

23373 7590 04/15/2014
 SUGHRUE MION, PLLC
 2100 PENNSYLVANIA AVENUE, N.W.
 SUITE 800
 WASHINGTON, DC 20037

EXAMINER

DEMILLE, DANTON D

ART UNIT	PAPER NUMBER
----------	--------------

3993

MAIL DATE	DELIVERY MODE
-----------	---------------

04/15/2014	PAPER
------------	-------

Please find below and/or attached an Office communication concerning this application or proceeding.

The time period for reply, if any, is set in the attached communication.

Ex Parte Reexamination Interview Summary – Pilot Program for Waiver of Patent Owner’s Statement	Control No.	Patent Under Reexamination is Requested
	90/013,201	6059576
	Examiner	Art Unit
	DANTON DEMILLE	3993

-- The MAILING DATE of this communication appears on the cover sheet with the correspondence address. --

All participants (USPTO official and patent owner):

- | | |
|------------------------------|---------------------------|
| (1) Patricia Volpe, CRU | (3) Quadeer Ahmed, 60,835 |
| (2) William H. Mandir, 32153 | (4) |

Date of Telephonic Interview:04/14/2014.

A. The USPTO official requested waiver of the patent owner’s statement pursuant to the pilot program for waiver of patent owner’s statement in ex parte reexamination proceedings.*

- The patent owner **agreed** to waive its right to file a patent owner’s statement under 35 U.S.C. 304 in the event reexamination is ordered for the above-identified patent.
- The patent owner **did not agree** to waive its right to file a patent owner’s statement under 35 U.S.C. 304 at this time.
- USPTO personnel were unable to reach the patent owner.**

B. The Patent Owner of record telephoned the Office and indicated they would like to participate in the pilot program for waiver of patent owner’s statement in ex parte reexamination proceedings.*

- The Patent owner of record telephoned the Office and **agreed** to waive its right to file a patent owner’s statement under 35 U.S.C. 304 in the event reexamination is ordered for the above-identified patent.

The patent owner is not required to file a written statement of this telephone communication under 37 CFR 1.560(b) or otherwise. However, any disagreement as to this interview summary must be brought to the immediate attention of the USPTO, and no later than one month from the mailing date of this interview summary. Extensions of time are governed by 37 CFR 1.550(c).

*For more information regarding this pilot program, see *Pilot Program for Waiver of Patent Owner’s Statement in Ex Parte Reexamination Proceedings*, 75 Fed. Reg. 47269 (August 5, 2010), available on the USPTO Web site at <http://www.uspto.gov/patents/law/notices/2010.jsp>.

**The patent owner may contact the USPTO personnel at (571) 272-7705 or at the telephone number provided below if the patent owner decides to waive the right to file a patent owner’s statement under 35 U.S.C. 304.

/Patricia Volpe/ (571)272-6825
Signature and telephone number of the USPTO official, who contacted, was contacted by, or attempted to contact the patent owner.



UNITED STATES PATENT AND TRADEMARK OFFICE

UNITED STATES DEPARTMENT OF COMMERCE
United States Patent and Trademark Office
Address: COMMISSIONER FOR PATENTS
P.O. Box 1450
Alexandria, Virginia 22313-1450
www.uspto.gov

REEXAM CONTROL NUMBER	FILING OR 371 (c) DATE	PATENT NUMBER
90/013,201	04/04/2014	6059576

23373
SUGHRUE MION, PLLC
2100 PENNSYLVANIA AVENUE, N.W.
SUITE 800
WASHINGTON, DC 20037

**CONFIRMATION NO. 9930
REEXAM ASSIGNMENT NOTICE**



Date Mailed: 04/09/2014

NOTICE OF ASSIGNMENT OF REEXAMINATION REQUEST

The above-identified request for reexamination has been assigned to Art Unit 3993. All future correspondence to the proceeding should be identified by the control number listed above and directed to the assigned Art Unit.

A copy of this Notice is being sent to the latest attorney or agent of record in the patent file or to all owners of record. (See 37 CFR 1.33(c)). If the addressee is not, or does not represent, the current owner, he or she is required to forward all communications regarding this proceeding to the current owner(s). An attorney or agent receiving this communication who does not represent the current owner(s) may wish to seek to withdraw pursuant to 37 CFR 1.36 in order to avoid receiving future communications. If the address of the current owner(s) is unknown, this communication should be returned within the request to withdraw pursuant to Section 1.36.

/sdstevenson/

Legal Instruments Examiner
Central Reexamination Unit 571-272-7705; FAX No. 571-273-9900



UNITED STATES PATENT AND TRADEMARK OFFICE

UNITED STATES DEPARTMENT OF COMMERCE
United States Patent and Trademark Office
Address: COMMISSIONER FOR PATENTS
P.O. Box 1450
Alexandria, Virginia 22313-1450
www.uspto.gov

Table with 3 columns: REEXAM CONTROL NUMBER (90/013,201), FILING OR 371 (c) DATE (04/04/2014), PATENT NUMBER (6059576)

23373
SUGHRUE MION, PLLC
2100 PENNSYLVANIA AVENUE, N.W.
SUITE 800
WASHINGTON, DC 20037

CONFIRMATION NO. 9930
REEXAMINATION REQUEST
NOTICE



Date Mailed: 04/09/2014

NOTICE OF REEXAMINATION REQUEST FILING DATE
(Patent Owner Requester)

Requester is hereby notified that the filing date of the request for reexamination is 04/04/2014, the date the required fee of \$2,520 was received. (See CFR 1.510(d)).

A decision on the request for reexamination will be mailed within three months from the filing date of the request for reexamination. (See 37 CFR 1.515(a)).

Pursuant to 37 CFR 1.33(c), future correspondence in this reexamination proceeding will be with the latest attorney or agent of the record in the patent file.

The paragraphs checked below are part of this communication:

- 1. The party receiving the courtesy copy is the latest attorney or agent of record in the patent file.
2. The person named to receive the correspondence in this proceeding has not been made the latest attorney or agent of record in the patent file because:
A. Requester's claim of ownership of the patent is not verified by the record.
B. The request papers are not signed with a real or apparent binding signature.
C. The mere naming of a correspondence addressee does not result in that person being appointed as the latest attorney or agent of record in the patent file.
3. Addressee is the latest attorney or agent of record in the patent file.
4. Other

/sdstevenson/

Legal Instruments Examiner
Central Reexamination Unit 571-272-7705; FAX No. 571-273-9900

Litigation Search Report CRU 3999

Reexam Control No. 90/013,201

TO: Danton Demille
Location: CRU
Art Unit: 3993
Date: 04/09/2014

From: Patricia Volpe
Location: CRU 3999
MDE 4B21
Phone: (571) 272-6825
Patricia.volpe@uspto.gov

Search Notes

Litigation search for U.S. Patent Number: 6,059,576

- 1) I performed a KeyCite Search in Westlaw, which retrieves all history on the patent including any litigation.
- 2) I performed a search on the patent in Lexis CourtLink for any open dockets or closed cases.
- 3) I performed a search in Lexis in the Federal Courts and Administrative Materials databases for any cases found.
- 4) I performed a search in Lexis in the IP Journal and Periodicals database for any articles on the patent.
- 5) I performed a search in Lexis in the news databases for any articles about the patent or any articles about litigation on this patent.

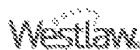

Date of Printing: Apr 09, 2014

KEYCITE

US PAT 6059576 TRAINING AND SAFETY DEVICE, SYSTEM AND METHOD TO AID IN PROPER MOVEMENT DURING PHYSICAL ACTIVITY, (May 09, 2000)

History**Direct History**

=> 1 **TRAINING AND SAFETY DEVICE, SYSTEM AND METHOD TO AID IN PROPER MOVEMENT DURING PHYSICAL ACTIVITY**, US PAT 6059576, 2000 WL 924492 (U.S. PTO Utility May 09, 2000)

Patent Family

2 APPARATUS FOR DETECTING MOVEMENT OF BODY PARTS DURING PHYSICAL ACTIVITY USING MOVEMENT SENSOR MEASURING DATA ASSOCIATED WITH MOVEMENT OF APPARATUS AND GENERATING SIGNALS INDICATIVE OF MOVEMENTS, Derwent World Patents Legal 1999-385180

Assignments

3 Action: ASSIGNMENT OF ASSIGNORS INTEREST (SEE DOCUMENT FOR DETAILS).
Number of Pages: 002, (DATE RECORDED: Aug 08, 2002)

Patent Status Files

.. Delayed Payment of Maintenance Fees, (OG DATE: Jun 20, 2006)
.. Expiration of Patent due to Failure to Pay Required Maintenance Fees,

Prior Art (Coverage Begins 1976)

- 6 APPARATUS AND METHOD FOR DETERMINING ANGLE OF INCLINATION AND RANGE OF MOTION OF VARIOUS HUMAN JOINTS THEREFROM, US PAT 5373858 Assignee: Technostix, Inc., (U.S. PTO Utility 1994)
- 7 APPARATUS FOR THE FUNCTIONAL ASSESSMENT OF HUMAN ACTIVITY, US PAT 5375610 Assignee: University of New Hampshire, (U.S. PTO Utility 1994)
- 8 APPARATUS FOR MONITORING SPINAL MOTION, US PAT 5398697 (U.S. PTO Utility 1995)
- 9 ARTHROMETER WITH GRAVITY SWITCHES AND ADJUSTABLE LIMIT SIGNALING, US PAT 5394888 (U.S. PTO Utility 1995)
- 10 BIOFEEDBACK LIFTING MONITOR, US PAT 4912638 (U.S. PTO Utility 1990)
- 11 COMPUTER CONTROLLED EXERCISE SYSTEM, US PAT 4934694 (U.S. PTO Utility 1990)

© 2014 Thomson Reuters. All rights reserved.

- 12 DEVICE FOR MEASURING MOTION CHARACTERISTICS OF A HUMAN JOINT, US PAT 5474088 Assignee: The Research Foundation of State, (U.S. PTO Utility 1995)
- 13 ELECTRONIC ANGULAR POSITION AND RANGE OF MOTION MEASURING DEVICE AND METHOD, US PAT 5042505 (U.S. PTO Utility 1991)
- 14 EXERCISE AND DIAGNOSTIC APPARATUS AND METHOD, US PAT 5348519 Assignee: Loredan Biomedical, Inc., (U.S. PTO Utility 1994)
- 15 EXERCISE AND TRAINING MACHINE WITH MICROCOMPUTER-ASSISTED TRAINING GUIDE, US PAT 4911427 Assignee: Sharp Kabushiki Kaisha, (U.S. PTO Utility 1990)
- 16 FLEXION MONITORING DEVICE, US PAT 5128655 (U.S. PTO Utility 1992)
- 17 HUMAN RANGE OF MOTION MEASUREMENT SYSTEM, US PAT 5588444 (U.S. PTO Utility 1996)
- 18 INSTRUMENTED ORTHOPEDIC RESTRAINING DEVICE AND METHOD OF USE, US PAT 5052375 Assignee: Stark, John G., (U.S. PTO Utility 1991)
- 19 INTEGRATED MOVEMENT ANALYZING SYSTEM, US PAT 5462065 (U.S. PTO Utility 1995)
- 20 INTEGRATED MOVEMENT ANALYZING SYSTEM, US PAT 5513651 (U.S. PTO Utility 1996)
- 21 JOINT DISPLACEMENT MEASUREMENT APPARATUS, US PAT 5435321 Assignee: E.V.C., (U.S. PTO Utility 1995)
- 22 LIFT TASK ANALYSIS SYSTEM, US PAT 5621667 Assignee: The United States of America as, (U.S. PTO Utility 1997)
- 23 MOTION CONTROL EVALUATION EMPLOYING A FOURIER TRANSFORM, US PAT 5715160 (U.S. PTO Utility 1998)
- 24 RANGE OF MOTION ANALYSIS SYSTEM, US PAT 5469862 Assignee: N.K. Biotechnical Engineering Company, (U.S. PTO Utility 1995)
- 25 RANGE OF MOTION MEASURING AND DISPLAYING DEVICE, US PAT 4665928 Assignee: Orthotronics, Inc., (U.S. PTO Utility 1987)
- 26 SYSTEM AND METHOD FOR SKILL ENHANCEMENT AND BEHAVIOR MODIFICATION, US PAT 4571682 Assignee: Computerized Sports Equipment, Inc., (U.S. PTO Utility 1986)

Copyright 2014 Newstex LLC
All Rights Reserved
National Law Review

April 7, 2014 Monday 5:35 PM EST

LENGTH: 676 words

HEADLINE: PTO Litigation Center Report - April 7, 2014

BYLINE: Sterne, Kessler, Goldstein Fox P.L.L.C.

BODY:

... Inc., United States District Court for the District of Connecticut Civil Action No. 3:12-CV-00198-SRU

Control # - 90/013,201

Date - 4/4/2014

Patent # - **6,059,576**

Inventor - BRANN, Theodore L.

Assignee - LOGANTREE LP

Title - TRAINING AND SAFETY DEVICE, SYSTEM AND METHOD TO AID IN PROPER MOVEMENT DURING PHYSICAL ACTIVITY

Co-pending Litigation - No documents ...

Source: **Combined Source Set 3**  - English Language News (Most recent Two Years)

Terms: **6059576 OR 6,059,576** (Suggest Terms for My Search)

View: KWIC

Date/Time: Wednesday, April 9, 2014 - 4:04 PM EDT



LexisNexis®

[About LexisNexis](#) | [Privacy Policy](#) | [Terms & Conditions](#) | [Contact Us](#)

Copyright © 2014 LexisNexis, a division of Reed Elsevier Inc. All rights reserved.

976228 (08) 6059576 May 9, 2000

UNITED STATES PATENT AND TRADEMARK OFFICE GRANTED PATENT

6059576

Get Drawing Sheet 1 of 9
Access PDF of Official Patent *
Order Patent File History / Wrapper from REEDFAX@
Link to Claims Section

May 9, 2000

Training and safety device, system and method to aid in proper movement during physical activity

EXPIRATION:

May 9, 2004 - due to failure to pay maintenance fees. , (O.G. July 6, 2004)
May 9, 2004 - due to failure to pay maintenance fees. , (O.G. July 6, 2004)
May 24, 2006 - REINSTATED due to acceptance of delayed payment of maintenance fee. , (O.G. June 20, 2006)
May 24, 2006 - REINSTATED due to acceptance of delayed payment of maintenance fee. , (O.G. June 20, 2006)

INVENTOR: BRANN THEODORE L -

APPL-NO: 976228 (08)

FILED-DATE: November 21, 1997

GRANTED-DATE: May 9, 2000

ASSIGNEE-AT-ISSUE:
BRANN; THEODORE L.

ASSIGNEE-AFTER-ISSUE:
August 8, 2002 - ASSIGNMENT OF ASSIGNORS INTEREST (SEE DOCUMENT FOR DETAILS)., LOGANTREE L P PO BOX 2345BOERNE, TEXAS, 78006, Reel and Frame Number: 013169/0942

LEGAL-STATUS:

August 8, 2002 - ASSIGNMENT
November 26, 2003 - MAINTENANCE FEE REMINDER MAILED
May 10, 2004 - REINSTATEMENT AFTER MAINTENANCE FEE PAYMENT CONFIRMED
July 6, 2004 - EXPIRED DUE TO FAILURE TO PAY MAINTENANCE FEE
May 5, 2006 - FEE PAYMENT
May 5, 2006 - SURCHARGE FOR LATE PAYMENT
May 22, 2006 - PATENT REINSTATED DUE TO THE ACCEPTANCE OF A LATE MAINTENANCE FEE
November 19, 2007 - MAINTENANCE FEE REMINDER MAILED
May 7, 2008 - FEE PAYMENT
May 7, 2008 - SURCHARGE FOR LATE PAYMENT
November 9, 2011 - FEE PAYMENT
November 26, 2003 - Maintenance Fee Reminder Mailed.
May 10, 2004 - Patent Reinstated After Maintenance Fee Payment Confirmed.
May 5, 2006 - Surcharge, Petition to Accept Pymt After Exp, Unintentional.
May 5, 2006 - Payment of Maintenance Fee, 4th Yr, Small Entity.

May 5, 2006 - Petition Related to Maintenance Fees Filed.
May 24, 2006 - Petition Related to Maintenance Fees Granted.
November 19, 2007 - Maintenance Fee Reminder Mailed.
May 7, 2008 - 7.5 yr surcharge - late pmt w/in 6 mo, Small Entity.
May 7, 2008 - Payment of Maintenance Fee, 8th Yr, Small Entity.
May 20, 2008 - Payor Number Assigned.
November 9, 2011 - Payment of Maintenance Fee, 12th Yr, Small Entity.

PRIM-EXMR: Cheng; Joe H.

CORE TERMS: microprocessor, wearer, battery, user, sensor, alarm, exceeded, monitor, memory, detected, reset, clock, indicator, flag, computer, warning, visual, idle, power source, monitoring, monitored, audible, detect, measuring device, threshold, worn, programmed, download, angular, input

NO-OF-CLAIMS: 29

NO-OF-FIGURES: 9

Source: [Legal > / . . . / > Utility, Design and Plant Patents](#) 

Terms: **PATNO= 6059576** (Suggest Terms for My Search)

View: Custom

Segments: Appl-no, Assignee, Cert-correction, Date, Exmr, Expiration-date, Filed, Inventor, Legal-status, Lit-reex, No-of-claims, No-of-figures, Patno, Prim-exmr, Reexam-litigate, Ref-patno, Reissue, Rel-patno, Title

Date/Time: Wednesday, April 9, 2014 - 4:04 PM EDT

LexisNexis® CourtLink®

Switch Client | My Briefcase | Order Runner Documents | Lexis.com | Sign Out |
Welcome, Patricia Velpe

Single Search - with Terms and Connectors

Enter keywords - Search multiple dockets & documents Info

 [Search](#) > [Patent Search](#) > [Searching](#)

Patent Search 6059576 4/9/2014

No cases found.

(Charges for search still apply)

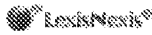
 [About LexisNexis](#) | [Terms & Conditions](#) | [Pricing](#) | [Privacy](#) | [Customer Support - 1-888-311-1966](#) | Copyright © 2014 LexisNexis®. All rights reserved.

Patent Assignment Abstract of Title

Total Assignments: 1

Application #: 08976228

Filing Dt: 11/21/1997

Patent #: 6059576

Issue Dt: 05/09/2000

PCT #: NONE

Publication #: NONE

Pub Dt:

Inventor: THEODORE L. BRANN

Title: TRAINING AND SAFETY DEVICE, SYSTEM AND METHOD TO AID IN PROPER MOVEMENT DURING PHYSICAL ACTIVITY

Assignment: 1

Reel/Frame: 013169 / 0942

Received: 08/14/2002

Recorded: 08/08/2002

Mailed: 10/17/2002

Pages: 2

Conveyance: ASSIGNMENT OF ASSIGNORS INTEREST (SEE DOCUMENT FOR DETAILS).

Assignor: BRANN, THEODORE L.

Exec Dt: 08/07/2002

Assignee: LOGANTREE L P

PO BOX 2345
BOERNE, TEXAS 78006

Correspondent: LOGANTREE L P

THEODORE L. BRANN
PO BOX 2345
BOERNE, TX 78006

Search Results as of: 04/08/2014 10:37 AM

If you have any comments or questions concerning the data displayed, contact PRD / Assignments at 571-272-3350. v.2.2.4
Web interface last modified: Jul 8, 2013 v.2.2.4

INFORMATION DISCLOSURE STATEMENT BY APPLICANT (Not for submission under 37 CFR 1.99)	Application Number	Not Yet Assigned
	Confirmation Number	Not Yet Assigned
	Filing Date	April 4, 2014
	First Named Inventor	Theodore L. Brann
	Art Unit	Not Yet Assigned
	Examiner Name	Not Yet Assigned
	Attorney Docket Number	A209779

U.S. PATENTS						
Examiner Initials	Cite No	Patent Number	Kind Code	Issue Date	Name of Patentee or Applicant of cited Document	Pages, Columns, Lines, Where Relevant Passages or Relevant Figures Appear
	1.	5636146		1997-06-03	Flentov et al.	
	2.	6018705		2000-01-25	Gaudet et al.	
	3.	6266623	B1	2001-07-24	Vock et al.	

U.S. PATENT APPLICATION PUBLICATIONS						
Examiner Initials	Cite No	Publication Number	Kind Code	Publication Date	Name of Patentee or Applicant of cited Document	Pages, Columns, Lines, Where Relevant Passages or Relevant Figures Appear

FOREIGN PATENT DOCUMENTS								
Examiner Initials	Cite No	Foreign Document Number	Country Code	Kind Code	Publication Date	Name of Patentee or Applicant of cited Document	Pages, Columns, Lines, Where Relevant Passages or Relevant Figures Appear	T

NON-PATENT LITERATURE DOCUMENTS			
Examiner Initials	Cite No	Include name of the author (in CAPITAL LETTERS), title of the article (when appropriate), title of the item (book, magazine, journal, serial, symposium, catalog, etc.), date, page(s), volume-issue number(s), publisher, city, and/or country where published.	T

EXAMINER SIGNATURE			
Examiner Signature			Date Considered

*EXAMINER: Initial if reference considered, whether or not citation is in conformance with MPEP 609. Draw line through a citation if not in conformance and not considered. Include copy of this form with next communication to applicant.

1 See Kind Codes of USPTO Patent Documents at www.USPTO.GOV or MPEP 901.04. 2 Enter office that issued the document, by the two-letter code (WIPO Standard ST.3). 3 For Japanese patent documents, the indication of the year of the reign of the Emperor must precede the serial number of the patent document. 4 Kind of document by the appropriate symbols as indicated on the document under WIPO Standard ST.16 if possible. 5 Applicant is to place a check mark here if English language translation is attached.

**INFORMATION DISCLOSURE
STATEMENT BY APPLICANT**

(Not for submission under 37 CFR 1.99)

Application Number	Not Yet Assigned
Confirmation Number	Not Yet Assigned
Filing Date	April 4, 2014
First Named Inventor	Theodore L. Brann
Art Unit	Not Yet Assigned
Examiner Name	Not Yet Assigned
Attorney Docket Number	A209779

CERTIFICATION STATEMENT

Please see 37 CFR 1.97 and 1.98 to make the appropriate selection(s):

- That each item of information contained in the information disclosure statement was first cited in any communication from a foreign patent office in a counterpart foreign application not more than three months prior to the filing of the information disclosure statement. See 37 CFR 1.97(e)(1).

OR

- That no item of information contained in the information disclosure statement was cited in a communication from a foreign patent office in a counterpart foreign application, and, to the knowledge of the person signing the certification after making reasonable inquiry, no item of information contained in the information disclosure statement was known to any individual designated in 37 CFR 1.56(c) more than three months prior to the filing of the information disclosure statement. See 37 CFR 1.97(e)(2).

- That each item of information contained in the Information Disclosure Statement filed concurrently herewith: (i) was first cited in any communication from a patent office in a counterpart foreign or international application or from the Office, and this communication was not received by any individual designated in § 1.56(c) more than thirty days prior to the filing of the Information Disclosure Statement; or (ii) is a communication that was issued by a patent office in a counterpart foreign or international application or by the Office, and this communication was not received by any individual designated in § 1.56(c) more than thirty days prior to the filing of the Information Disclosure Statement. See 37 CFR 1.704(d).
- Fee set forth in 37 CFR 1.17 (p) has been submitted herewith.
- The USPTO is directed and authorized to charge all required fees, except for the Issue Fee and the Publication Fee, to Deposit Account No. 19-4880. Please also credit any overpayments to said Deposit Account.
- None

WASHINGTON OFFICE
23373
CUSTOMER NUMBER

SIGNATURE

A signature of the applicant or representative is required in accordance with CFR 1.33, 10.18. Please see CFR 1.4(d) for the form of the signature.

Signature	/William H. Mandir/	Date (YYYY-MM-DD)	2014-04-04
Name/Print	William H. Mandir	Registration Number	32,156

*EXAMINER: Initial if reference considered, whether or not citation is in conformance with MPEP 609. Draw line through a citation if not in conformance and not considered. Include copy of this form with next communication to applicant.

1 See Kind Codes of USPTO Patent Documents at www.USPTO.GOV or MPEP 901.04. 2 Enter office that issued the document, by the two-letter code (WIPO Standard ST.3). 3 For Japanese patent documents, the indication of the year of the reign of the Emperor must precede the serial number of the patent document. 4 Kind of document by the appropriate symbols as indicated on the document under WIPO Standard ST.16 if possible. 5 Applicant is to place a check mark here if English language translation is attached.



US006266623B1

(12) **United States Patent**
Vock et al.

(10) **Patent No.:** **US 6,266,623 B1**
(45) **Date of Patent:** **Jul. 24, 2001**

(54) **SPORT MONITORING APPARATUS FOR DETERMINING LOFT TIME, SPEED, POWER ABSORBED AND OTHER FACTORS SUCH AS HEIGHT**

(75) Inventors: **Curtis A. Vock**, Charlestown; **Dennis Darcy**, Dracut; **Peter Flentov**, Carlisle, all of MA (US)

(73) Assignee: **PhatRat Technology, Inc.**, Longmont, CO (US)

(*) Notice: Subject to any disclaimer, the term of this patent is extended or adjusted under 35 U.S.C. 154(b) by 0 days.

(21) Appl. No.: **08/867,083**

(22) Filed: **Jun. 2, 1997**

Related U.S. Application Data

(63) Continuation-in-part of application No. 08/344,485, filed on Nov. 21, 1994, now Pat. No. 5,636,146.

(51) **Int. Cl.**⁷ **G01L 5/00**

(52) **U.S. Cl.** **702/44; 702/41; 702/56; 73/862.53; 73/379.01**

(58) **Field of Search** 702/41-44, 60-62, 702/68, 77, 79, 144, 150, 158, 160, 94-97, 139, 141, 142, 149, 165, 166, 175-178, 180, 182, 183, 187, 188, 191, 195, 198, 46, FOR 151, 145; 235/105; 364/528.26; 73/597, 384, 387, 488-493, 495, 503, 1.15, 1.37, 1.42, 1.43, 1.79, 1.81, 781, 782, 789-491, 795, 802, 862.02, 862.03, 862.044-862.046, 862.391, 474, 862.393, 862.53, 862.571, 379.01-379.05, 379.08, 382 R, 382 G, 383, 726, 720, 865.1, 2, 4, DIG. 1, 494, 596, 570, 581-584, 587, 588, 602, 646-648, 660; 73/669, 11.04, 11.05, 11.07, 11.08, 1.82; 340/232 R, 988, 989; 368/10, 14; 324/140 R, 151, 142, 140 D, 113, 114, 116, 76.21, 160, 162, 178; 377/3, 16, 17, 20, 23, 24.1, 24.2; 701/213, 216, 37, 45-48, 70, 91; 346/33 R, 37, 40, 33 D, 45, 55, 57, 64; 280/DIG. 13; 441/69, 70; 482/70, 74; 342/357

(56) **References Cited**

U.S. PATENT DOCUMENTS

3,978,725	9/1976	Hadtke	73/182
4,089,057	5/1978	Eriksson	364/562
4,371,188	* 2/1983	Hull	73/862.045
4,371,945	2/1983	Karr et al.	364/561
4,423,630	* 1/1984	Morrison	73/379.01
4,516,110	* 5/1985	Overmyer	73/862.02
4,694,694	* 9/1987	Vlakancic	367/14
4,722,222	2/1988	Purdy et al.	73/597
4,757,453	* 7/1988	Nasiff	73/379.01
4,757,714	7/1988	Purdy et al.	73/597
4,763,275	* 8/1988	Carlin	73/11.04
4,774,679	* 9/1988	Carlin	73/862.53
4,873,867	* 10/1989	McPherson et al.	73/493

(List continued on next page.)

Primary Examiner—Hal Wachsmann

(74) *Attorney, Agent, or Firm*—Lathrop & Gage, L.C.

(57) **ABSTRACT**

The invention detects the loft time and/or speed of a vehicle, such as a sporting vehicle, during activities of moving and jumping. A loft sensor detects when the vehicle leaves the ground and when the vehicle returns to the ground. A microprocessor subsystem converts the sensed information to determine a loft time. A display shows the recorded loft time to a user of the system. In addition, a speed sensor can detect the vehicle's speed for selective display to the user. The invention could be used in sporting activities such as snowboarding where users loft into the air on ski jumps and catch "air" time but have no quantitative measure of the actual time lapse in the air. Therefore, users in skiing can use invention to record, store, and playback selected information relating to their sporting day, including the total amount of "air" time for the day and information such as dead time, i.e., time not spent on the slopes. The invention can also measure power absorbed by a user over a predetermined time interval.

42 Claims, 23 Drawing Sheets

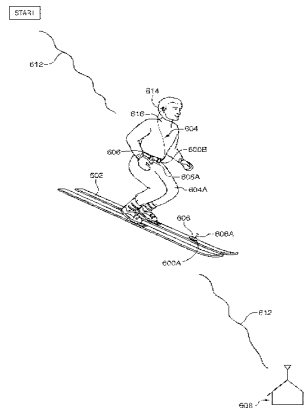

US 6,266,623 B1

Page 2

U.S. PATENT DOCUMENTS

5,036,467	*	7/1991	Blackburn et al.	701/47	5,452,269	9/1995	Cherdak	368/10	
5,144,226	*	9/1992	Rapp	702/198	5,471,405	11/1995	Marsh	364/556	
5,162,828		11/1992	Furness et al.	353/122	5,546,307	*	8/1996	Mazur et al.	701/46
5,295,085		3/1994	Hoffacker	364/558	5,618,995	*	4/1997	Otto et al.	73/669
5,343,445		8/1994	Cherdak	368/10	5,646,857	*	7/1997	McBurney et al.	701/213
5,436,838	*	7/1995	Miyamori	701/46					

* cited by examiner

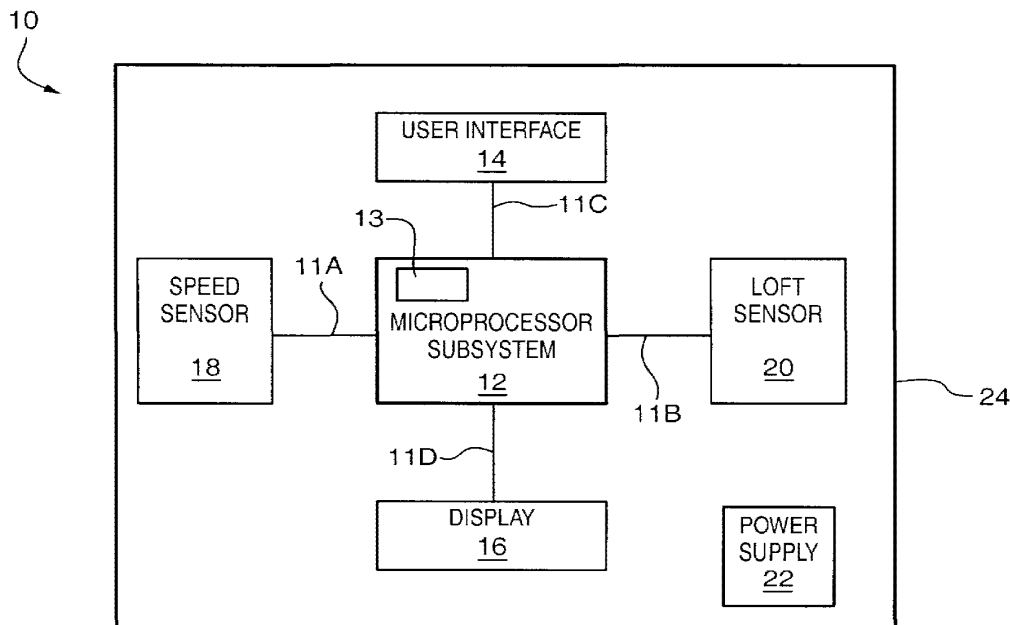

FIG. 1

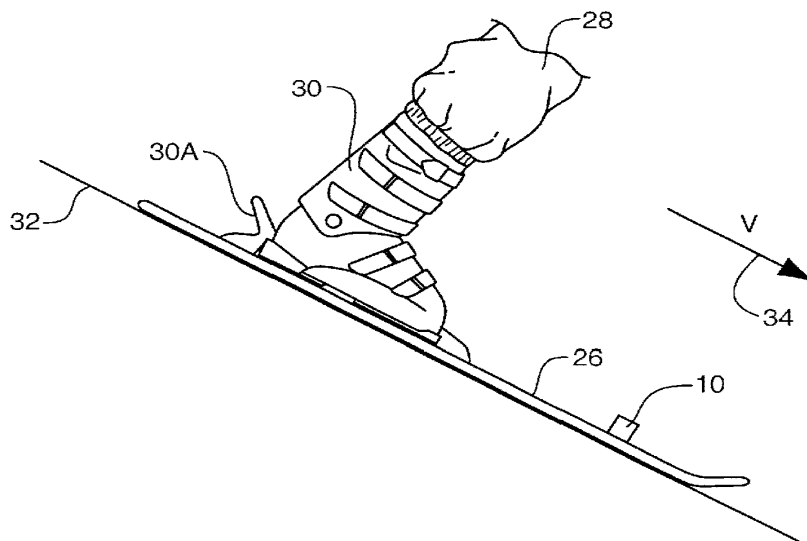

FIG. 2

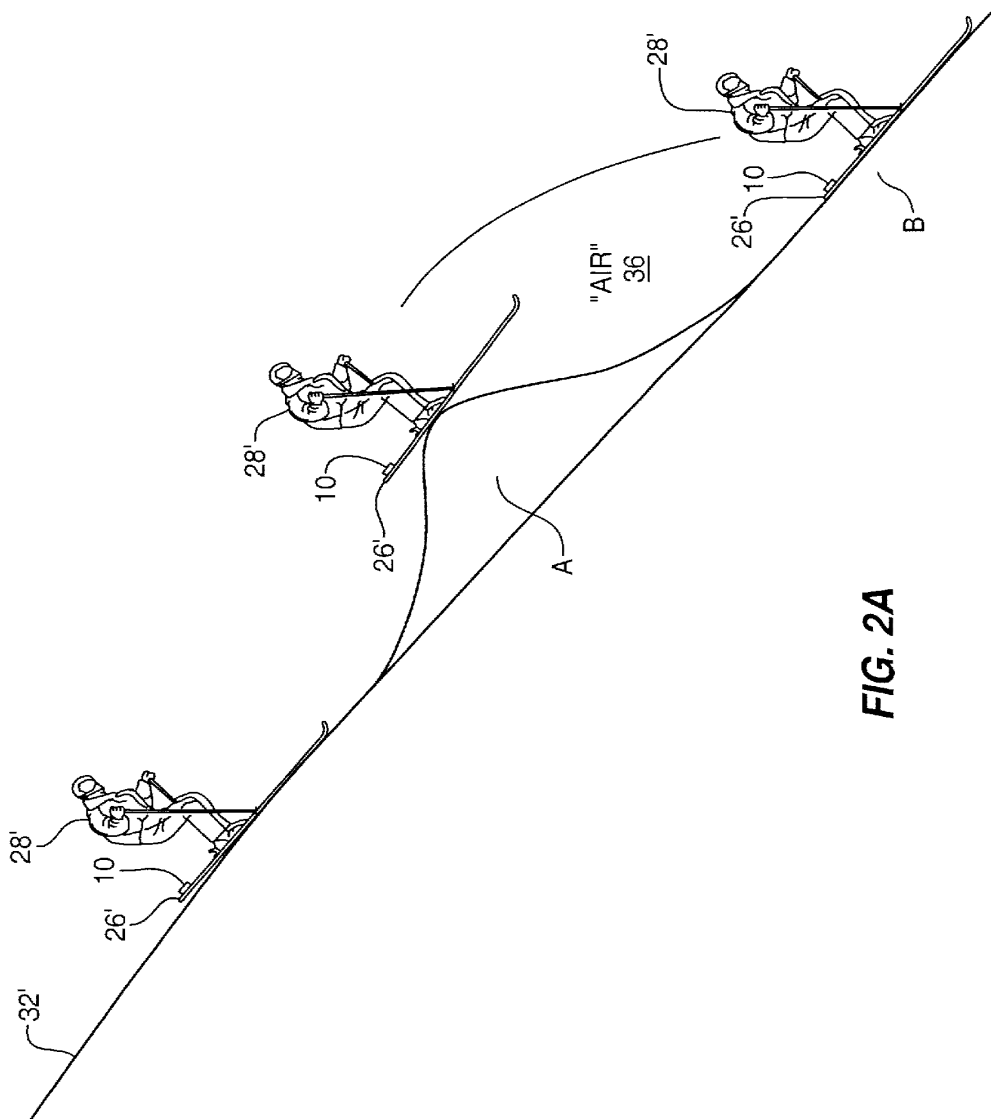

FIG. 2A

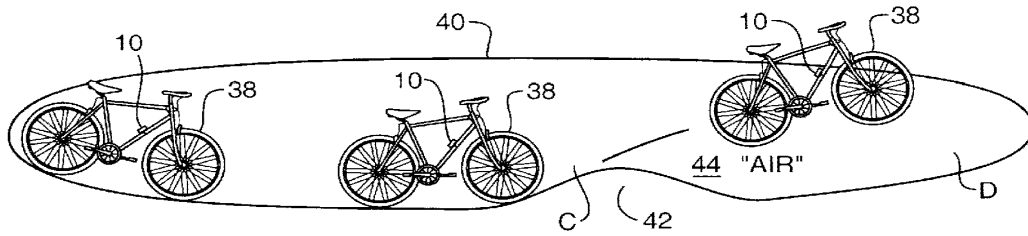

FIG. 2B

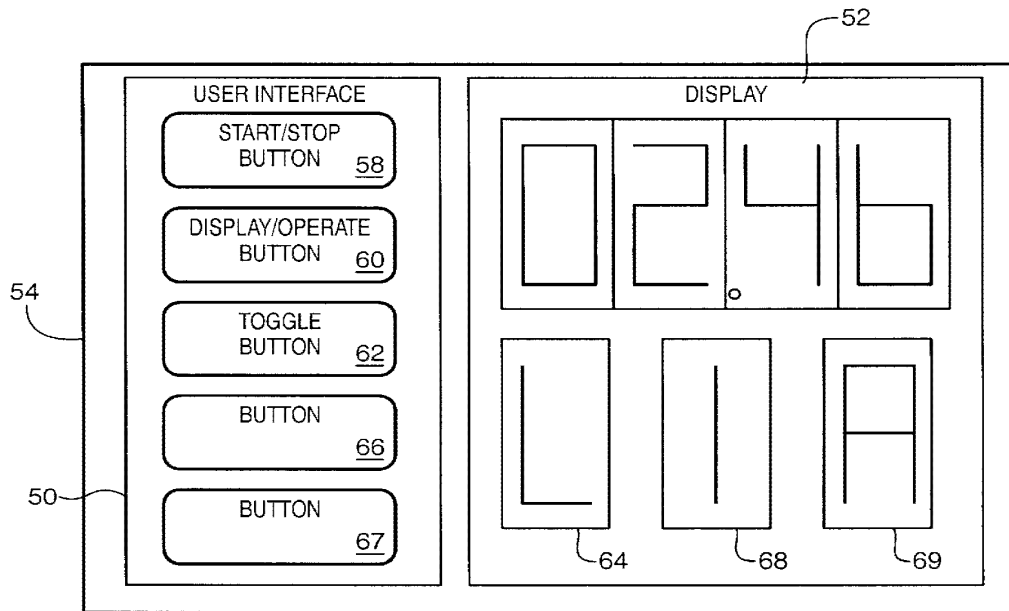

FIG. 3

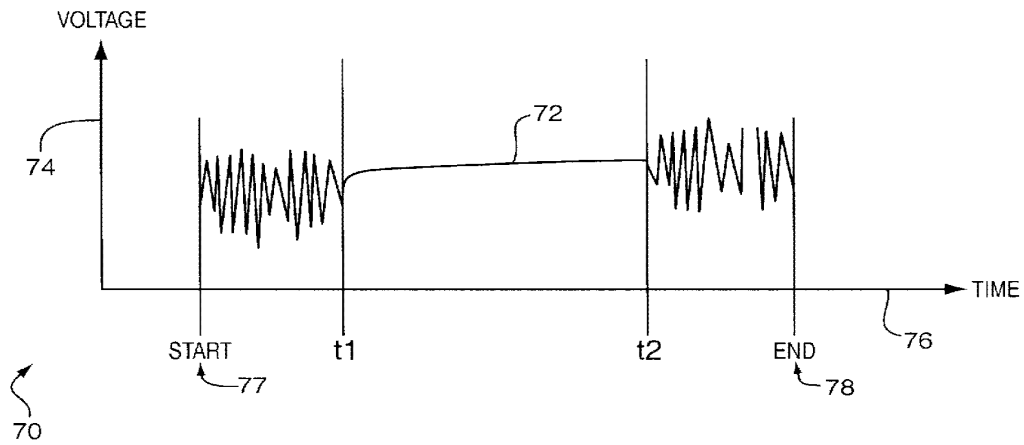

FIG. 4



FIG. 5

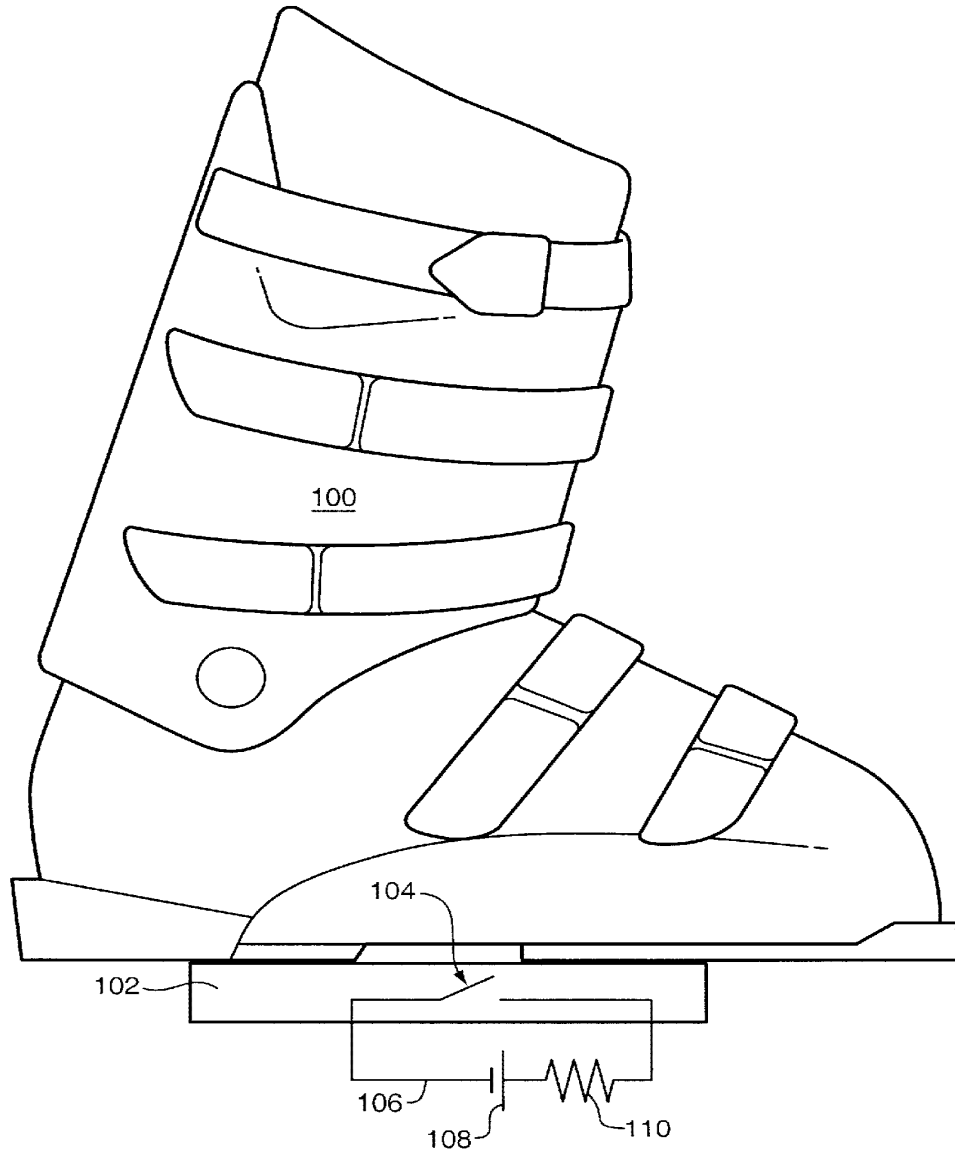

FIG. 6

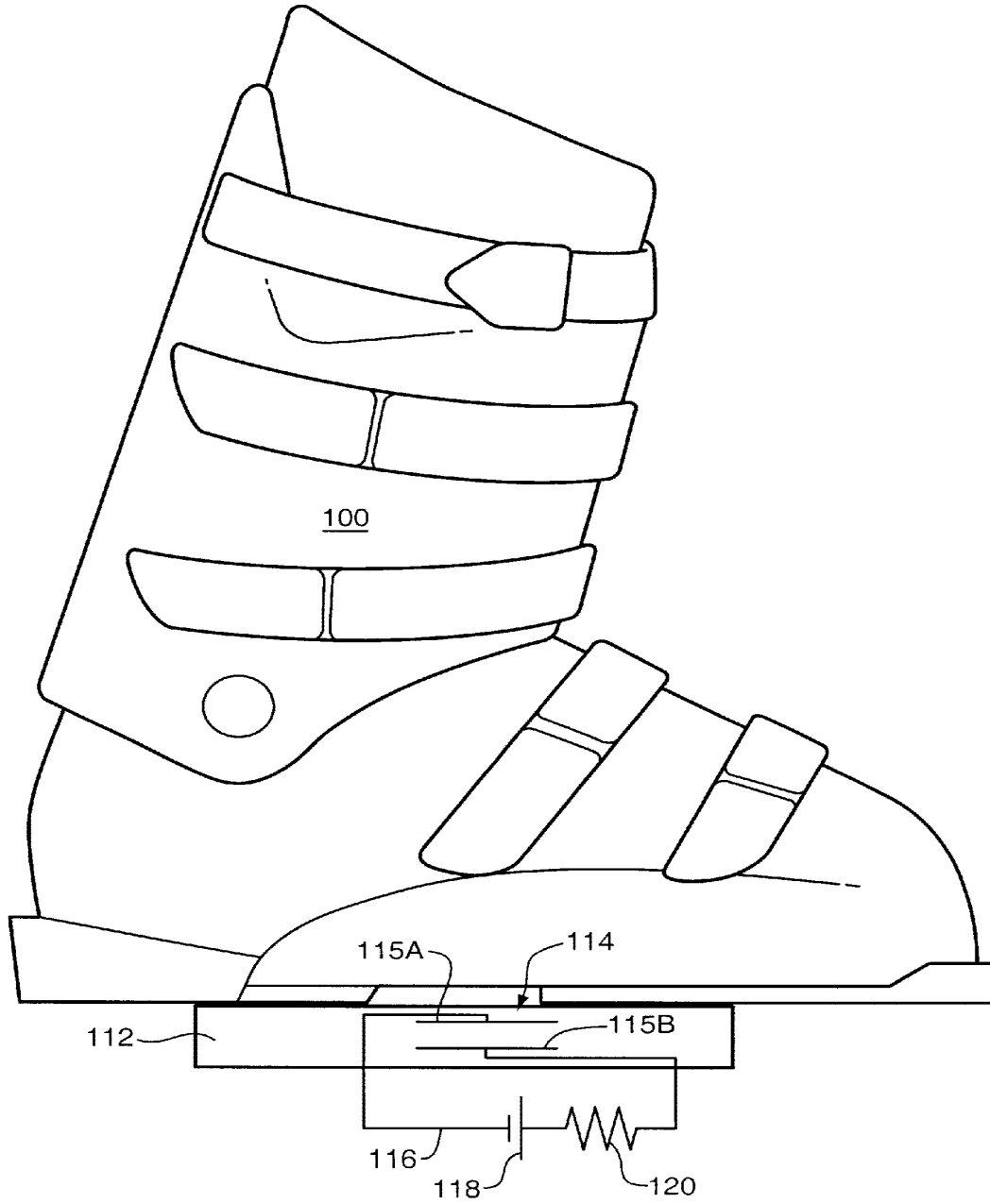

FIG. 7

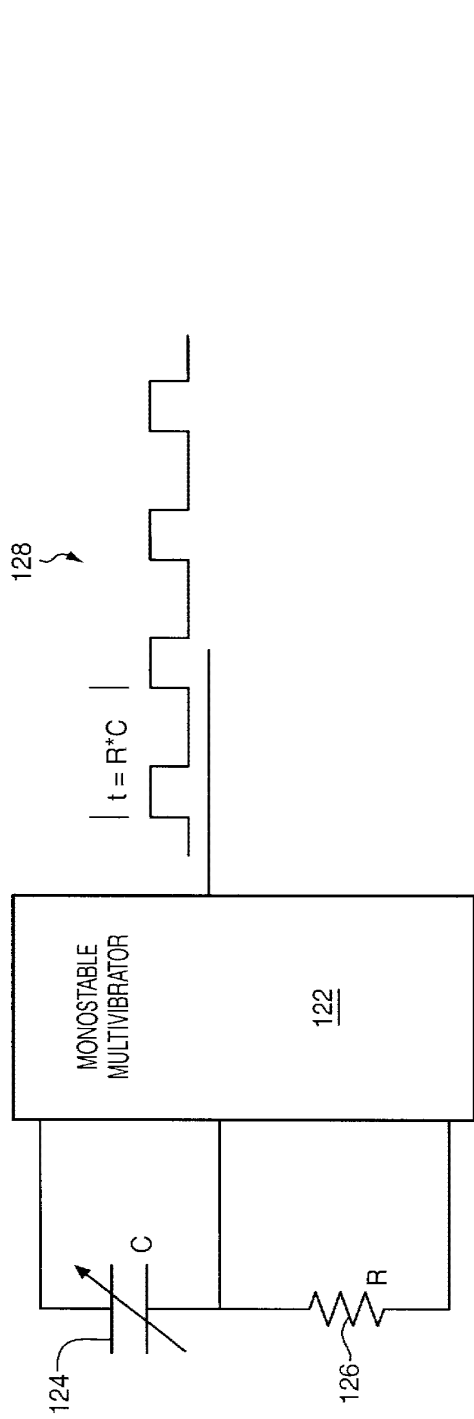

FIG. 8

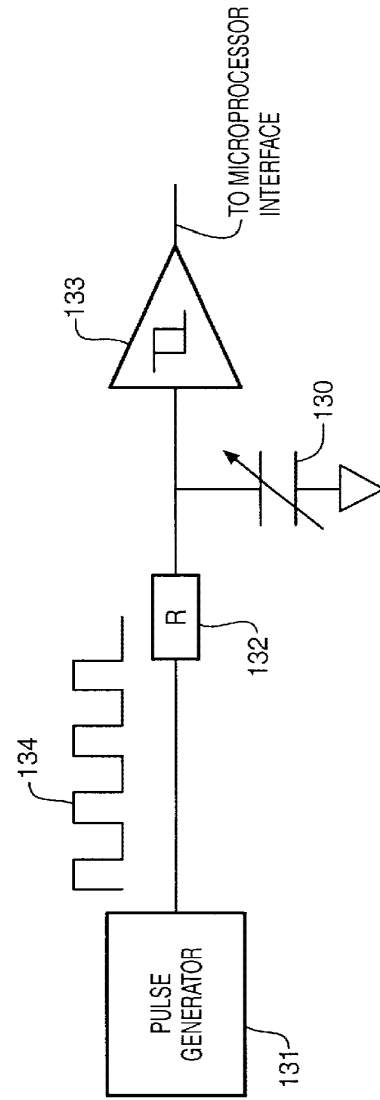

FIG. 9

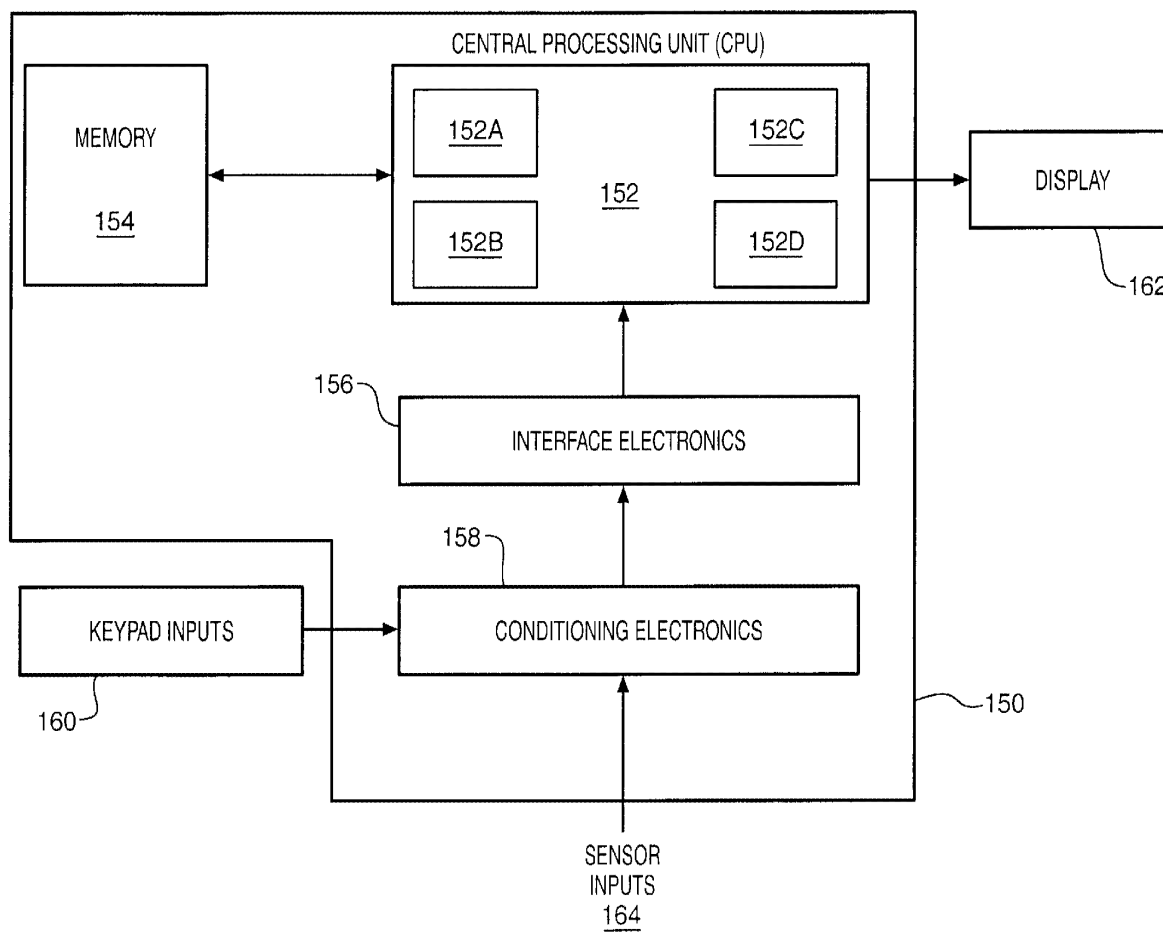

FIG. 10

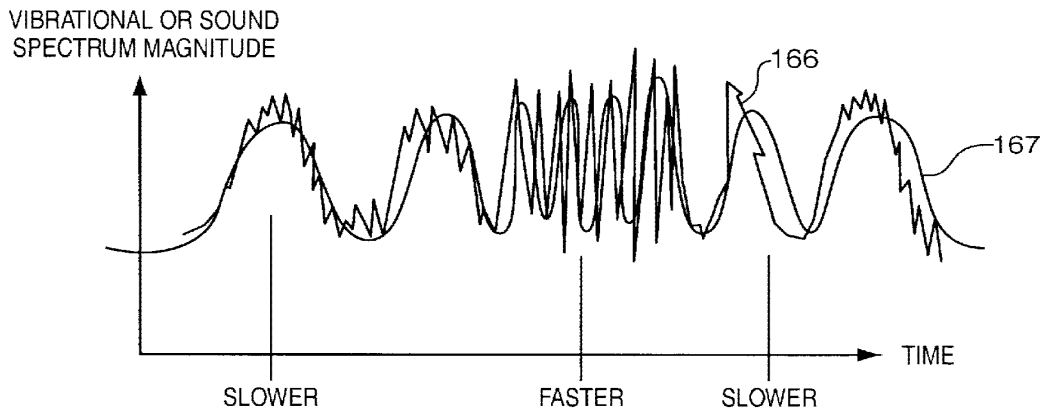

FIG. 11

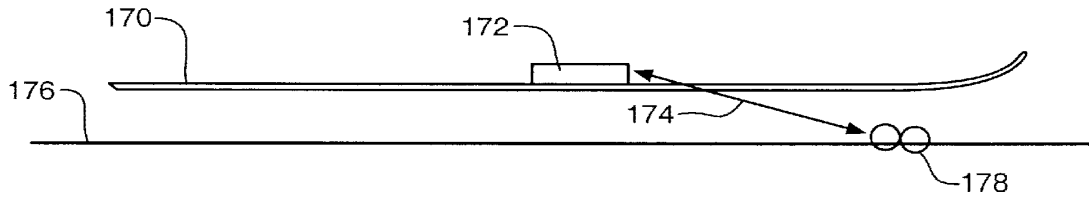

FIG. 12

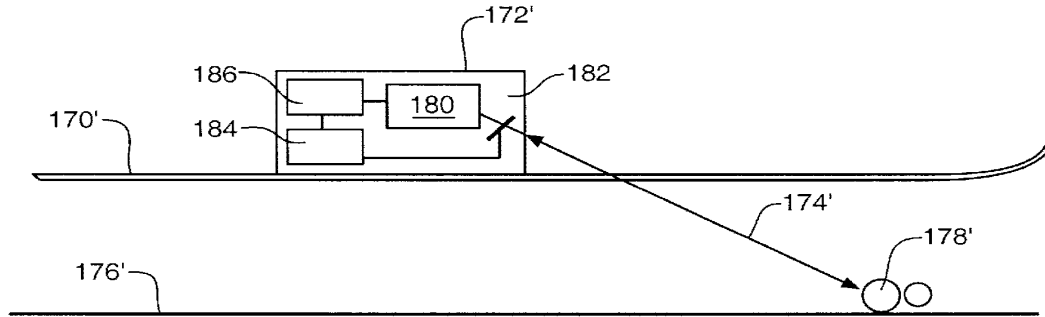

FIG. 12A

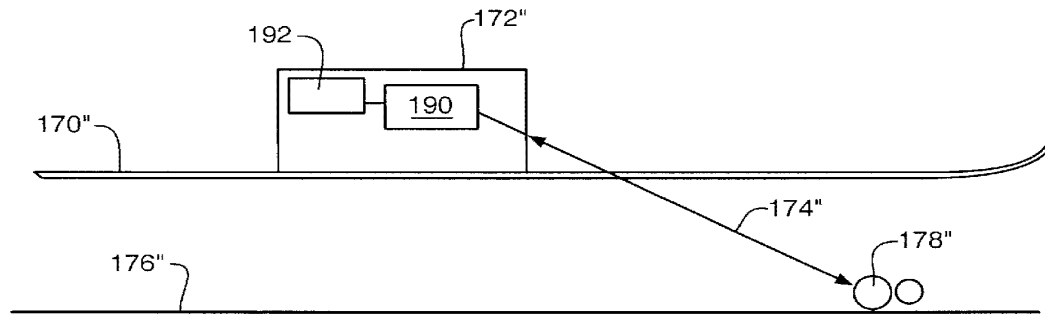

FIG. 12B

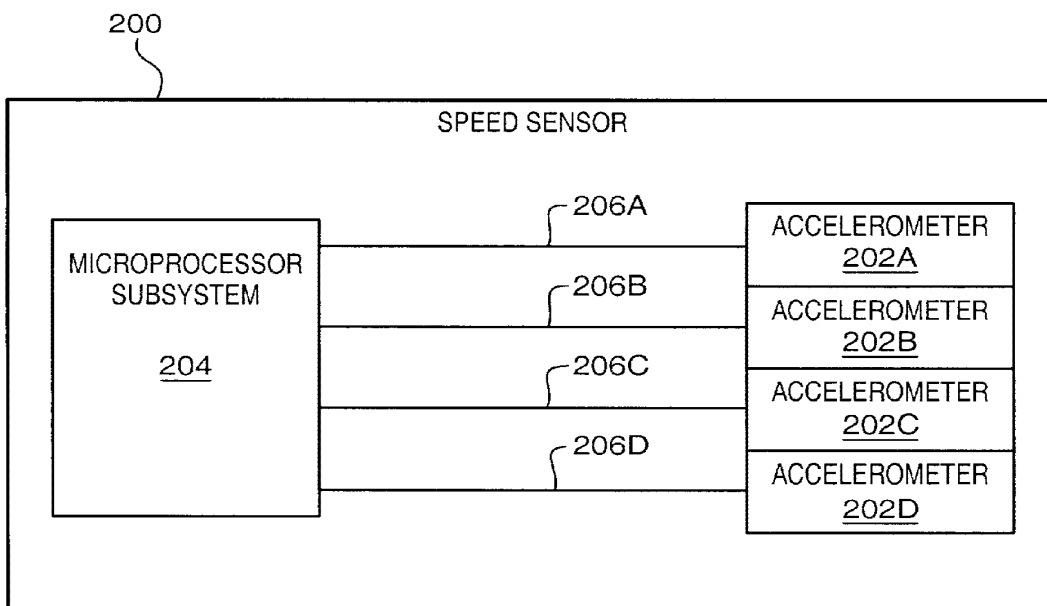

FIG. 13

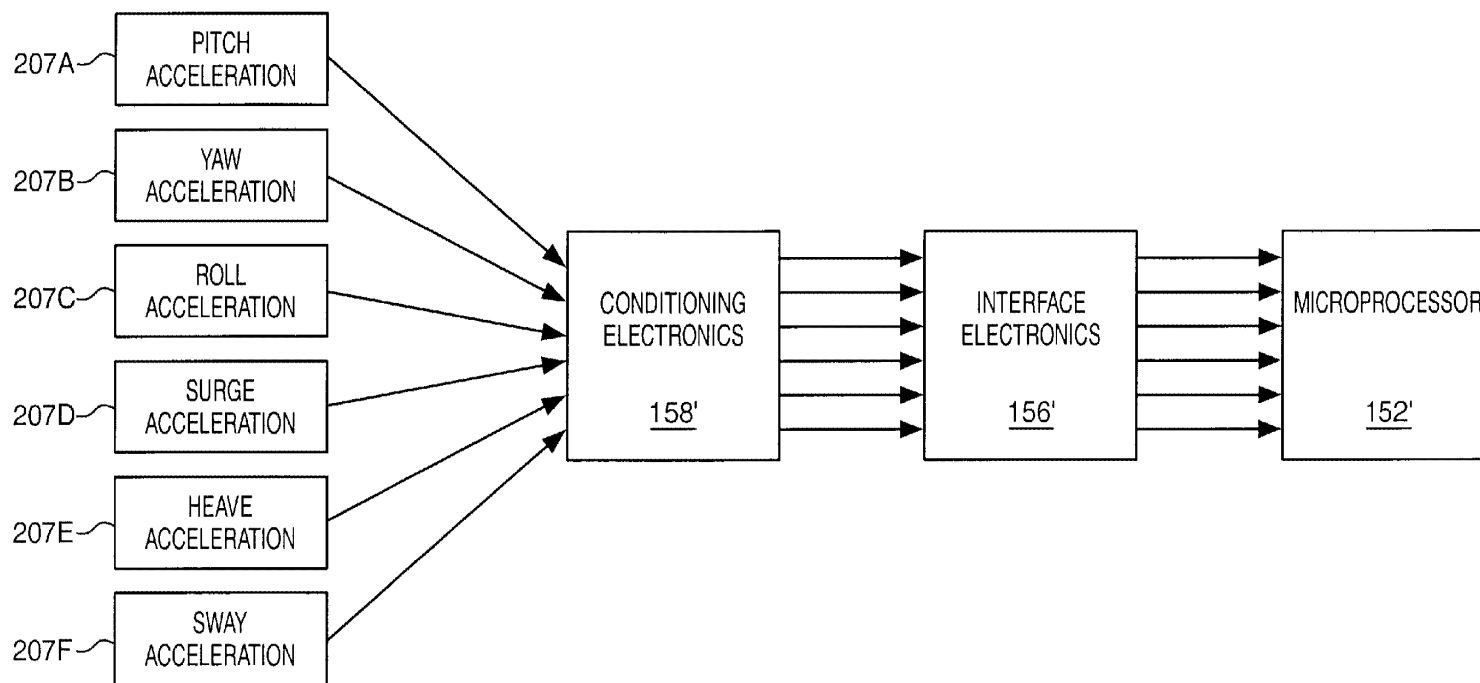

FIG. 14

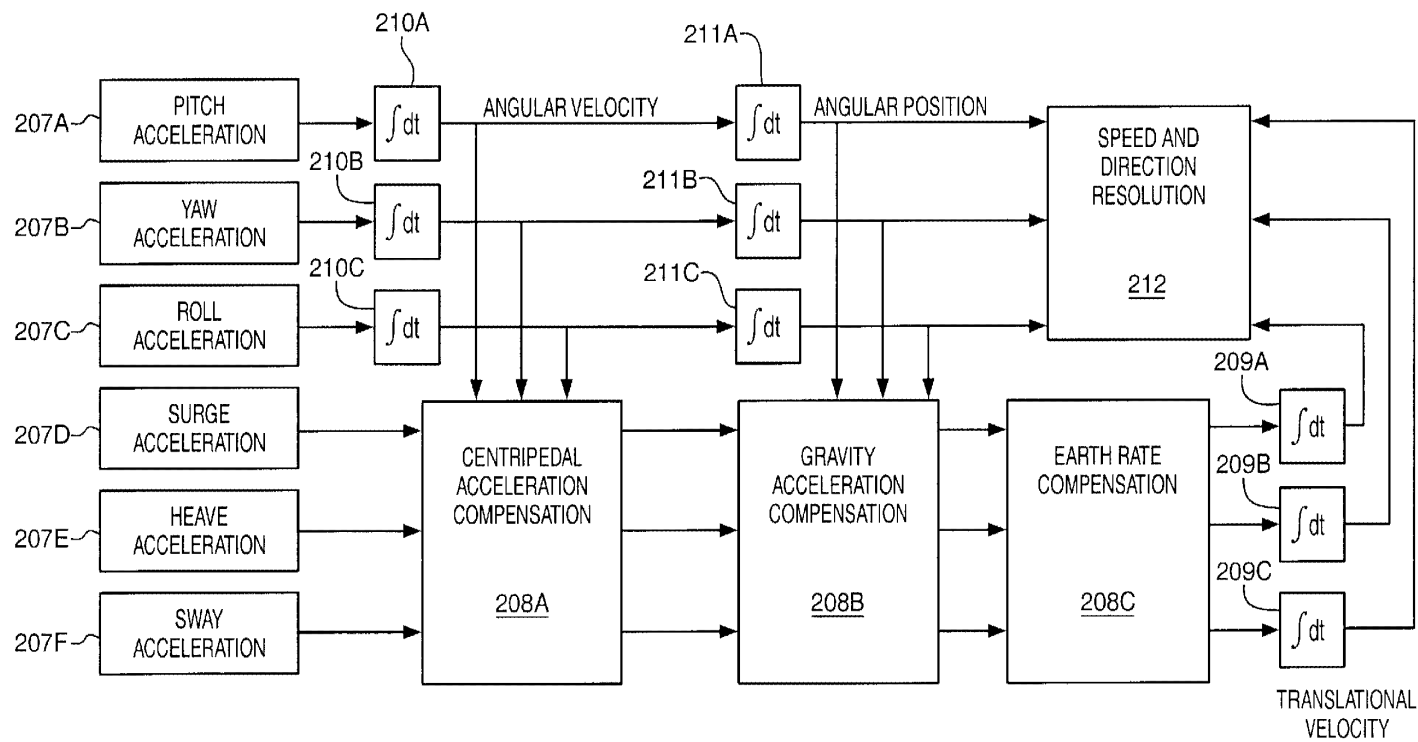

FIG. 14A

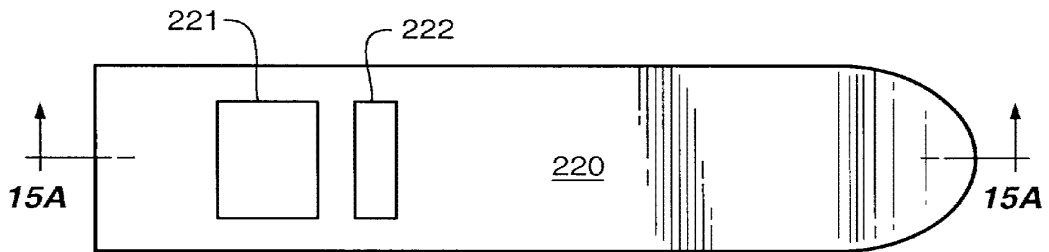

FIG. 15

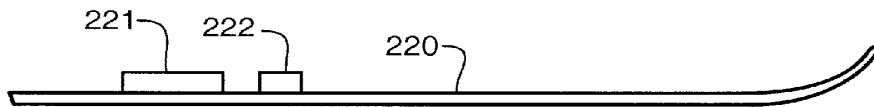

FIG. 15A

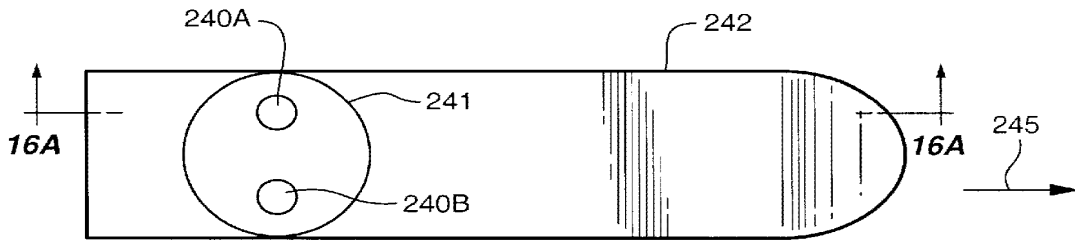

FIG. 16

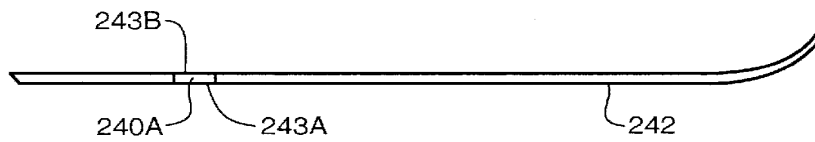

FIG. 16A

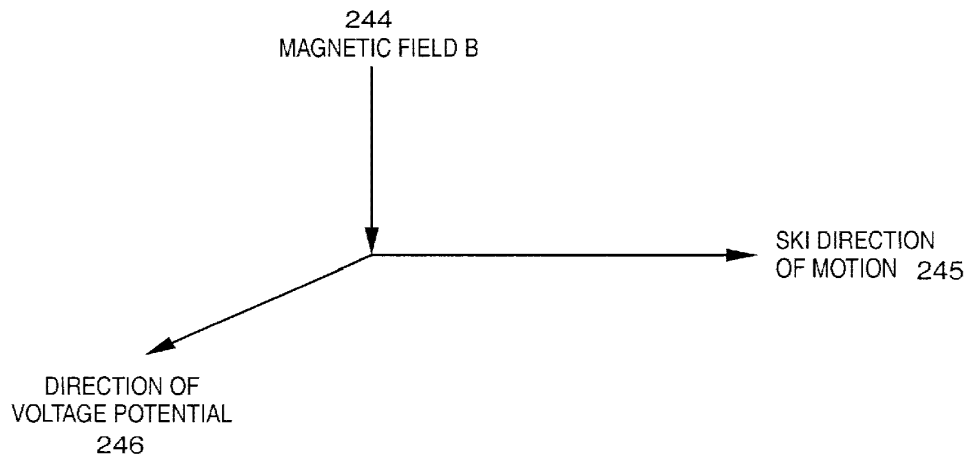

FIG. 16B

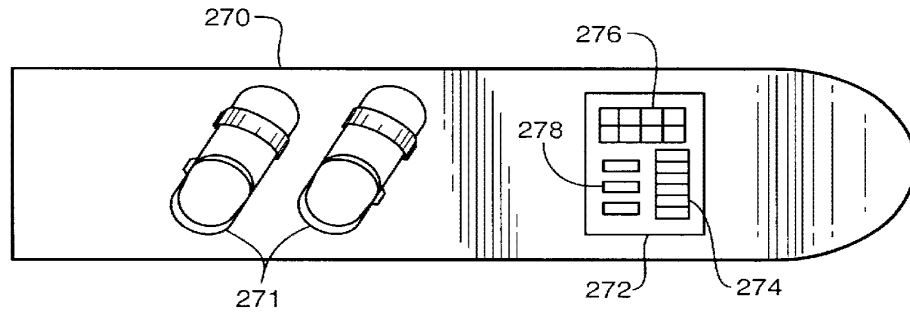

FIG. 17

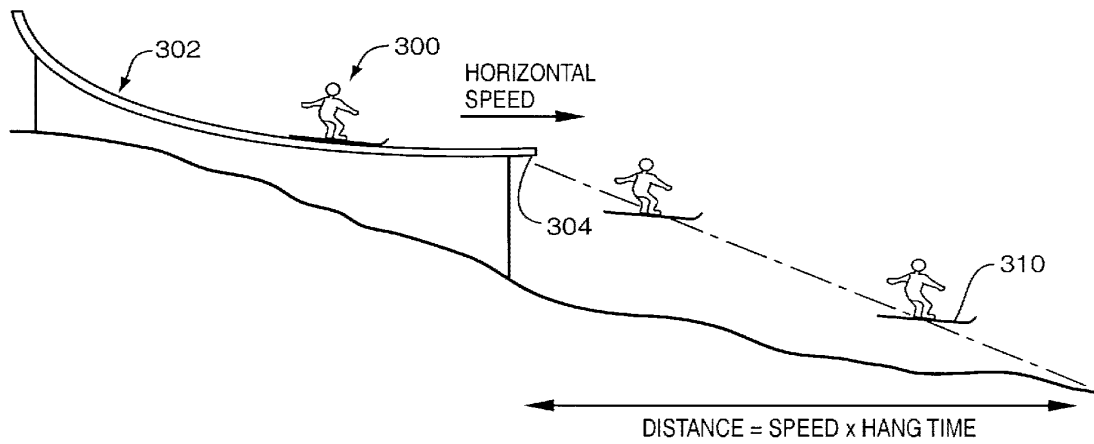

FIG. 18

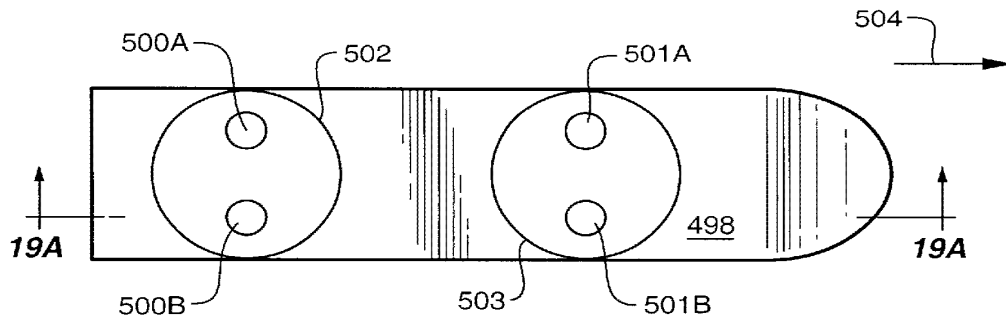

FIG. 19

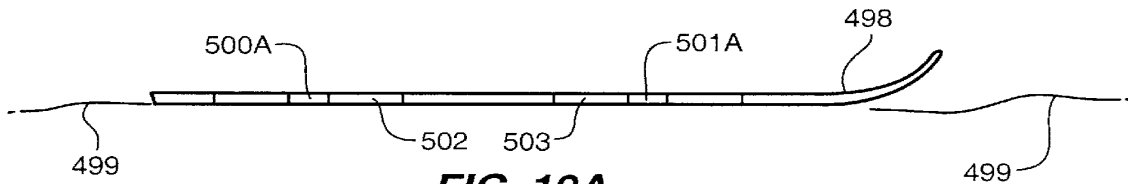
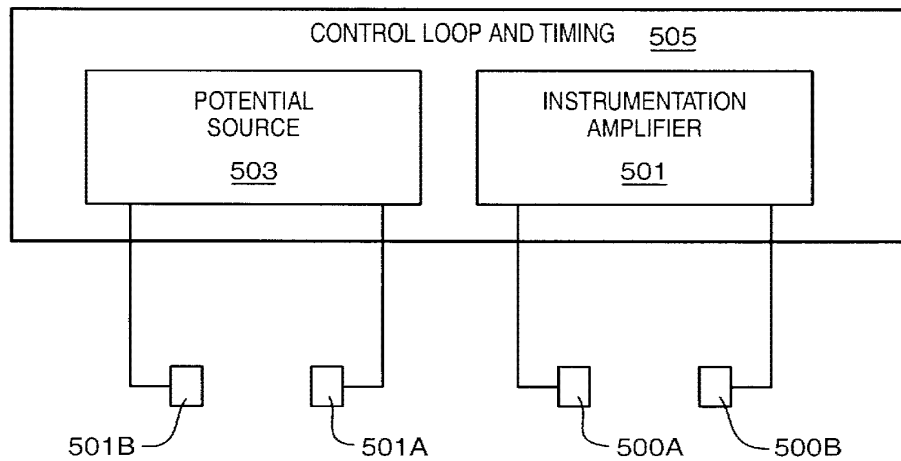

FIG. 19A

FIG. 19B



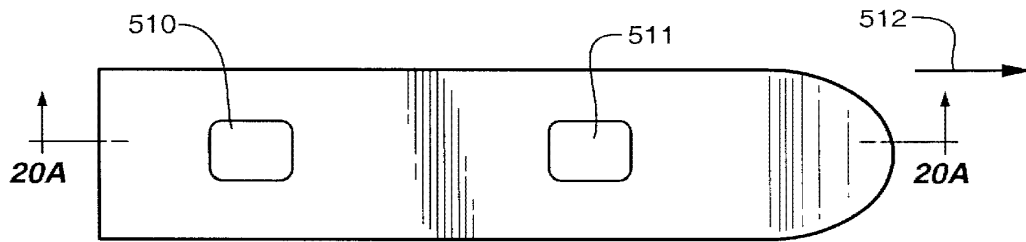

FIG. 20



FIG. 20A

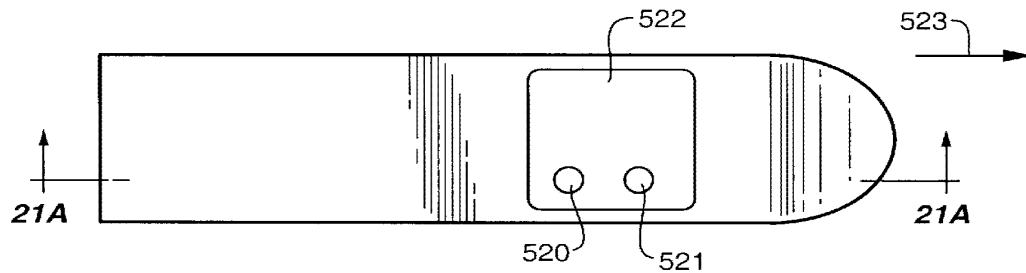

FIG. 21

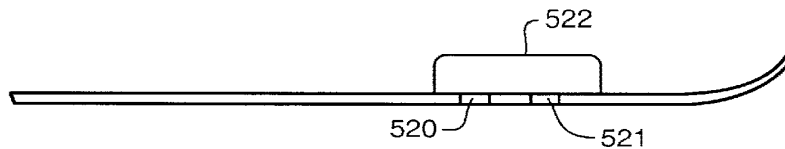

FIG. 21A

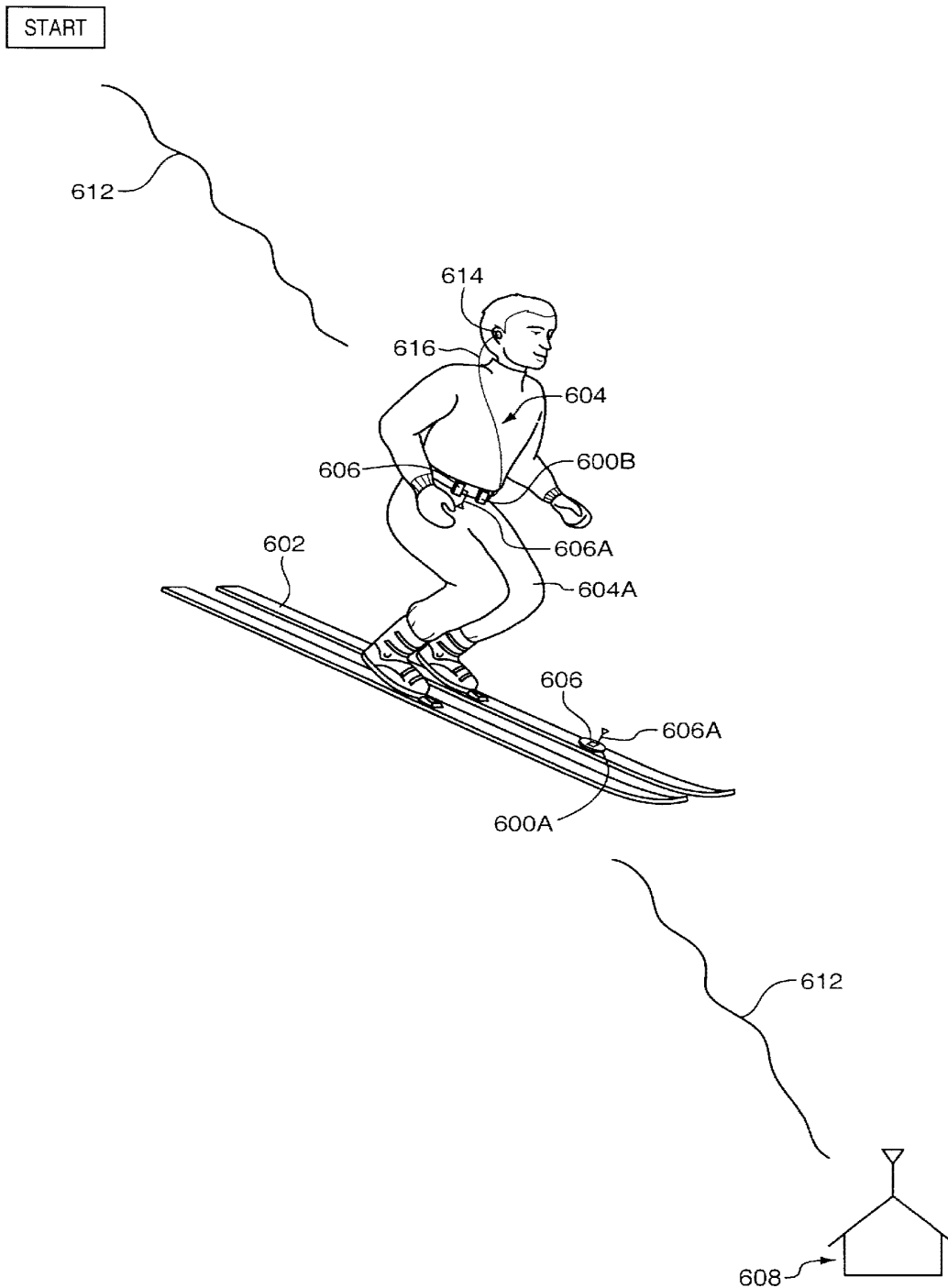

FIG. 22

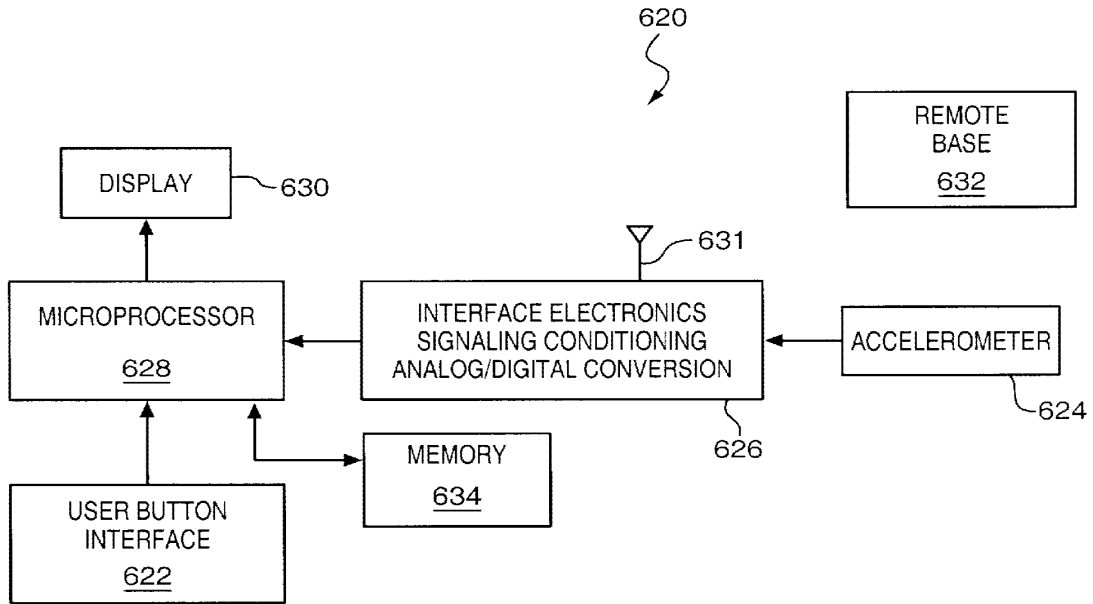

FIG. 23

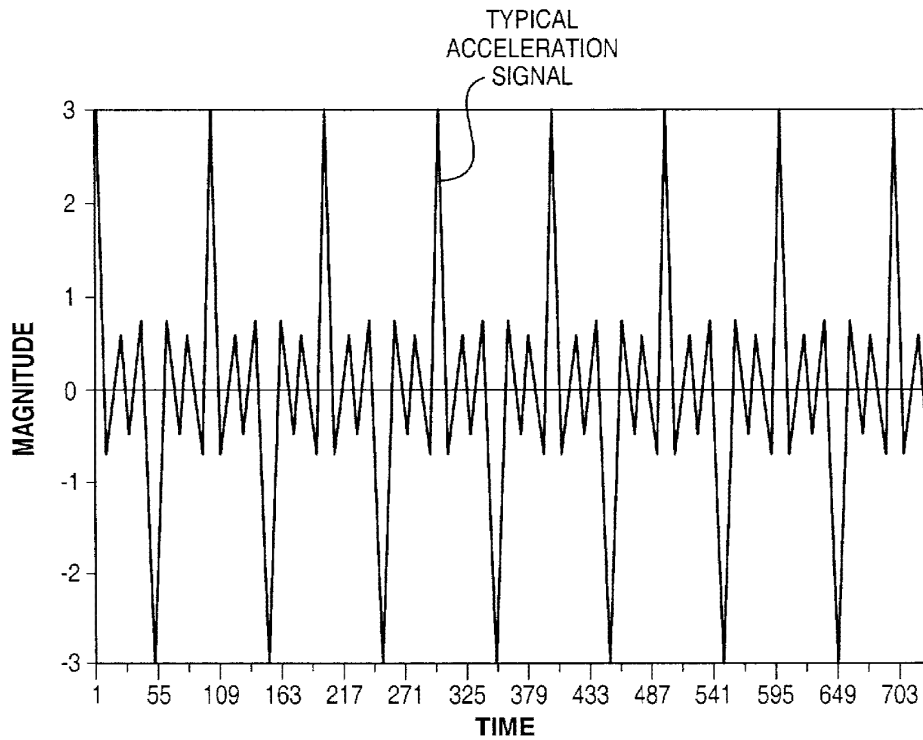

FIG. 24

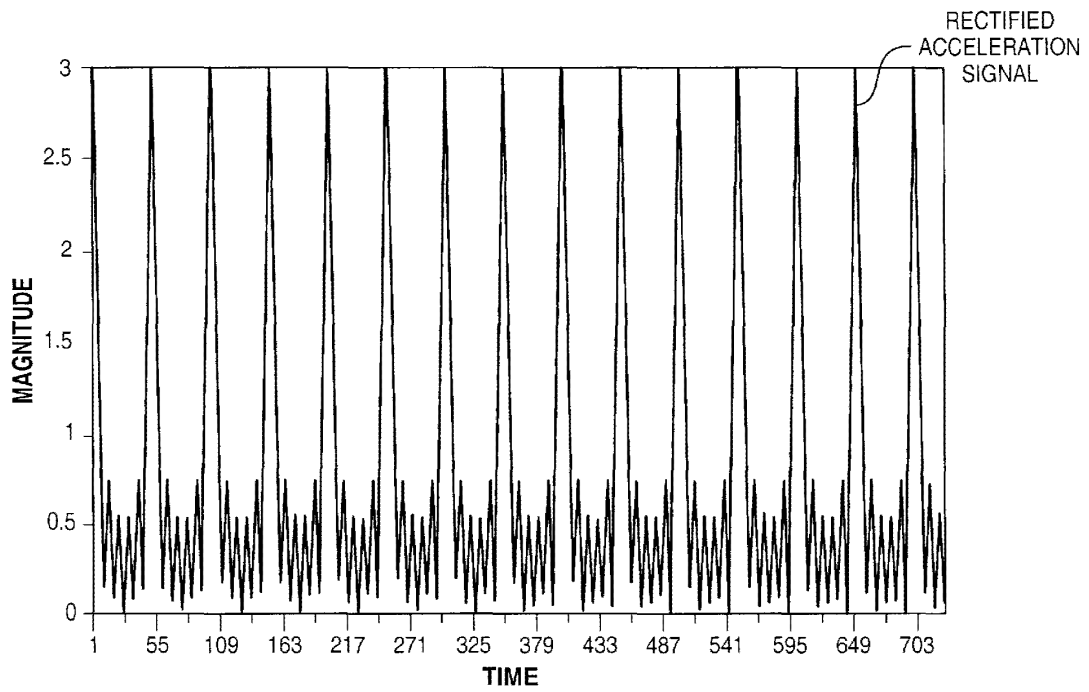

FIG. 25

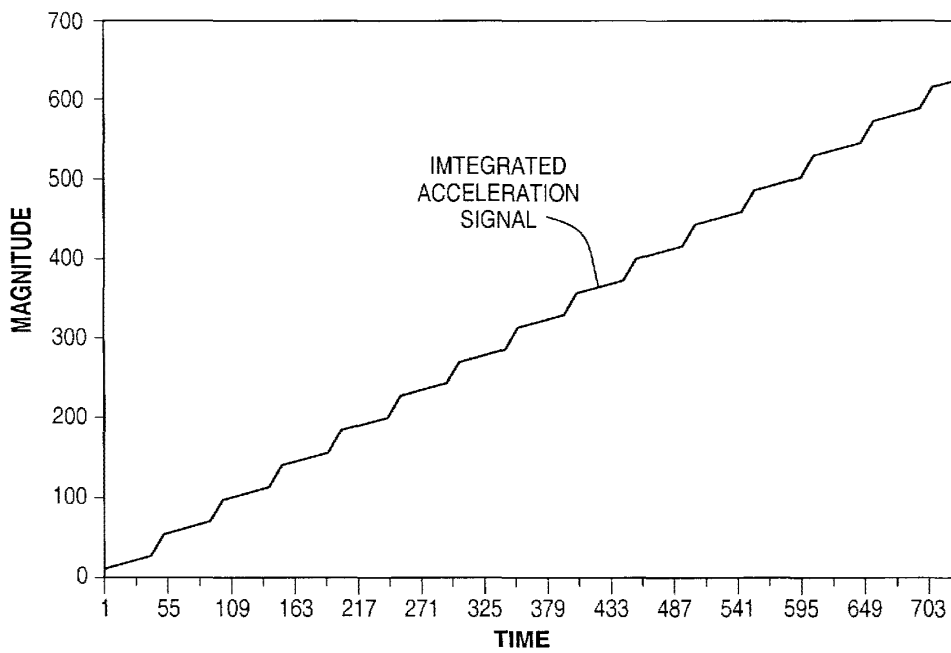

FIG. 26

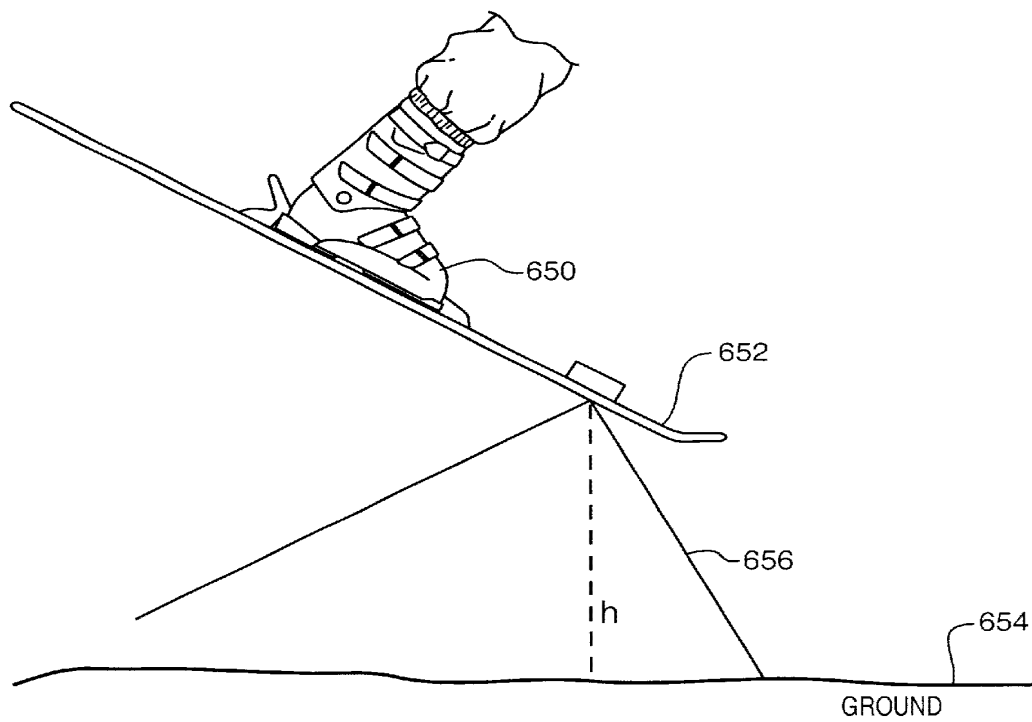

FIG. 27

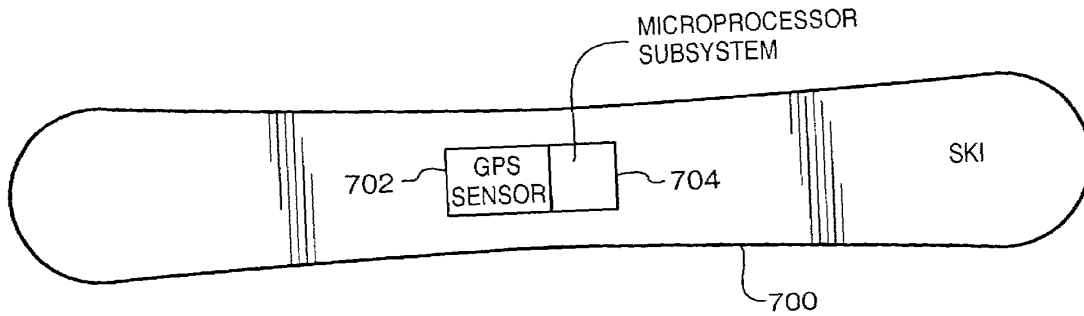

FIG. 28

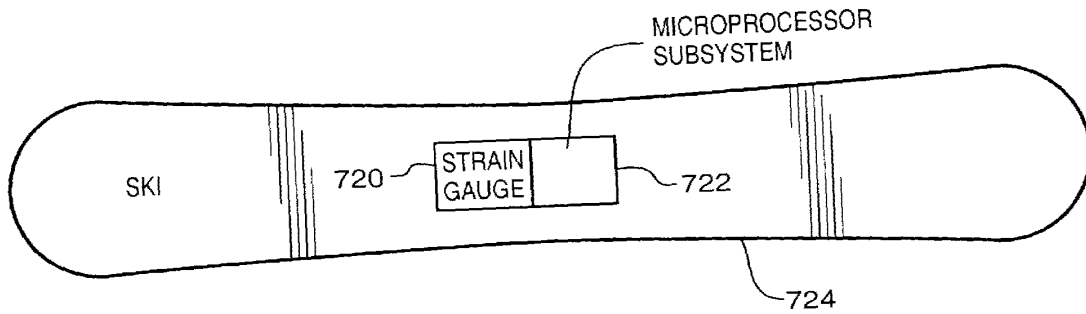

FIG. 29

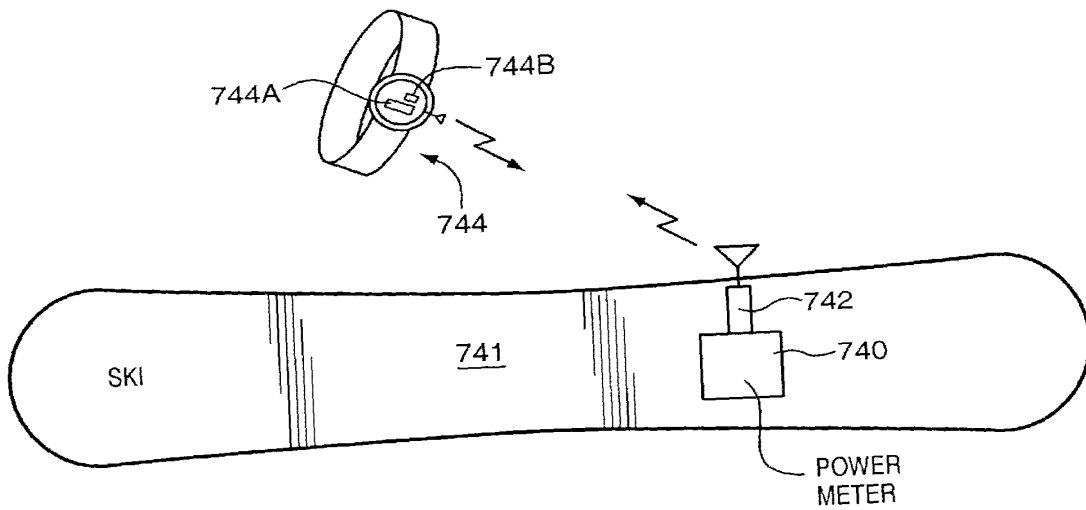

FIG. 30

1

**SPORT MONITORING APPARATUS FOR
DETERMINING LOFT TIME, SPEED,
POWER ABSORBED AND OTHER FACTORS
SUCH AS HEIGHT**

RELATED APPLICATIONS

This application is a continuation-in-part of commonly-owned U.S. application Ser. No. 08/344,485, filed on Nov. 21, 1994 now U.S. Pat. No. 5,636,146 which is hereby incorporated by reference. This application is related to U.S. application Ser. Nos. 08/764,758, now U.S. Pat. No. 5,960,380 and 09/089,232 pending.

FIELD OF THE INVENTION

The invention relates generally to the measurement of the loft time, power absorbed and speed of a vehicle relative to the ground. Such measurements are particularly useful in sporting activities like skiing, snowboarding and mountain biking where users desire information relating to their speed and/or loft, or "air" time.

BACKGROUND OF THE INVENTION

It is well known that many skiers enjoy high speeds and jumping motions while traveling down the slope. High speeds refer to the greater and greater velocities which skiers attempt in navigating the slope successfully (and sometimes unsuccessfully). The jumping motions, on the other hand, include movements which loft the skier into the air. Generally, the greater the skier's speed, the higher the skier's loft into the air.

The interest in high speed skiing is apparent simply by observing the velocity of skiers descending the mountain. The interest in the loft motion is less apparent; although it is known that certain enthusiastic skiers regularly exclaim "let's catch some air" and other assorted remarks when referring to the amount and altitude of the lofting motion.

The sensations of speed and jumping are also readily achieved in other sporting activities, such as in mountain biking. Many mountain bikers, like the aforementioned skiers, also crave greater speeds and "air" time.

However, persons in such sporting activities typically only have a qualitative sense as to speed and loft or "air" time. For example, a typical snowboarding person might regularly exclaim after a jump that she "caught" some "big sky," "big air" or "phat air" without ever quantitatively knowing how much time really elapsed in the air.

There are also other factors that persons sometimes assess qualitatively. For example, suppose a snowboarder goes down a double-diamond ski slope while a friend goes down a green, easy slope. When they both reach the bottom, the double-diamond snowboarder will have expended more energy than the other, generally, and will have worked up a sweat; while the green snowboarder will have had a relatively inactive ride down the slope. Currently, they cannot quantitatively compare how rough their journeys were relative to one another.

It is, accordingly, an object of the invention to provide apparatus and methods for determining the "air" time of participants in sporting activities such as skiing and mountain biking.

It is another object of the invention to provide apparatus and methods for determining the speed of participants in sporting activities such as skiing and mountain biking.

It is yet another object of the invention to provide improvements to sporting devices which are ridden by

2

sporting participants, and which provide a determination of speed and/or loft time of the device.

Still another object of the invention is to provide apparatus and methods for determining the amount of "power" or energy absorbed by a person during sporting activities.

These and other objects of the invention will become apparent in the description which follows.

SUMMARY OF THE INVENTION

The following U.S. patents provide useful background for the invention and are herein incorporated by reference: U.S. Pat. No. 5,343,445; U.S. Pat. No. 4,371,945; U.S. Pat. No. 4,757,714; U.S. Pat. No. 4,089,057; U.S. Pat. No. 3,978,725; and U.S. Pat. No. 5,295,085.

The invention concerns the detection and display of loft, or "air" time and/or speed of vehicles such as sporting vehicles, including skis, bikes, and snowboards. The invention thus provides a visual and quantitative measure of how much "air" time and, in certain aspects, how fast a user moves in a particular activity.

The invention provides, in one aspect, apparatus for determining the loft time of a moving vehicle off of a surface. A loft sensor senses a first condition that is indicative of the vehicle leaving the surface, and further senses a second condition indicative of the vehicle returning to the surface. A microprocessor subsystem, e.g., a microcontroller, determines a loft time that is based upon the first and second conditions, and the loft time is thereafter displayed to a user of the apparatus by a display, e.g., a LCD or LED display. Preferably, a power module such as a battery is included in the apparatus to power the several components. In addition, a housing preferably connects and protects the microprocessor subsystem and the user interface; and further such that the housing is attachable to the vehicle.

According to another aspect, the invention includes memory for storing information representative of at least one of the following: (i) the first and second conditions, (ii) the loft time, (iii) a speed of the vehicle, (iv) successive records of loft time, (v) an average loft time, (vi) a total loft time, (vii) a dead time, (viii) a real activity time, and (ix) a numerical ranking of successive records.

One preferred aspect of the invention includes a speed sensor, connected to the microprocessor subsystem, which senses a third condition that is indicative of a velocity of the vehicle. In this aspect, the microprocessor subsystem includes means for converting the third condition to information representative of a speed of the vehicle. Accordingly, the apparatus provides a user with both loft time, e.g., "air" time, and a speed of the vehicle.

In yet another aspect, the display of the invention can display selective information, including one or more of the following: the loft time; a speed of the vehicle; a peak loft time; an average loft time; a total loft time; a dead time; a real activity time; an average speed; an indication that loft time is being displayed; an indication that speed is being displayed; an indication that dead time is being displayed; an indication that real activity time is being displayed; successive records of loft information; successive records of speed information; a distance traveled by the vehicle; a height achieved by the vehicle off of the surface; and an indication of a number of a successive record relative to all successive records.

In still another aspect, the invention includes a user interface for providing external inputs to the apparatus,

3

including one or more of the following: a start/stop button for selectively starting and stopping the acquisition of data by the apparatus; a display-operate button for activating the display means selectively; a speed/loft toggle button for alternatively commanding a display of loft time information and speed information of the vehicle; means for commanding a display of successive records of loft time information selectively; means for commanding a display of successive records of speed information selectively; means for commanding a display of information corresponding to average loft time; means for commanding a display of information corresponding to average speed; means for commanding a display of dead time; means for commanding a display of distance traveled by the vehicle; means for commanding a display of height achieved by the vehicle off of the surface; and means for commanding a display of real activity time.

Preferably, the microprocessor subsystem of the invention includes a dock element, e.g., a 24-hour clock, for providing information convertible to an elapsed time. Accordingly, the subsystem can perform various calculations, e.g., dead time, on the data acquired by the apparatus for display to a user.

In another aspect, the loft sensor is constructed with one of the following technologies: (i) an accelerometer that senses a vibrational spectrum; (ii) a microphone assembly that senses a noise spectrum; (iii) a switch that is responsive to a weight of a user of the vehicle; (iv) a voltage-resistance sensor that generates a voltage indicative of a speed of the vehicle; and (v) a plurality of accelerometers connected for evaluating a speed of the vehicle.

In a preferred aspect, the loft sensor of the invention senses a spectrum of information, e.g., a vibrational or sound spectrum, and the microprocessor subsystem determines the first and second conditions relative to a change in the spectrum of information. Further, the microprocessor subsystem interprets the change in the spectrum to determine the loft time.

For example, one aspect of a loft sensor according to the invention includes one or more accelerometers that generate a vibrational spectrum of the vehicle. In such an aspect, the first and second conditions correspond to a change in the vibrational spectrum. By way of another example, one loft sensor of the invention includes a microphone subassembly that generates a noise spectrum of the vehicle; and, in this aspect, the first and second conditions correspond to a change in the detected noise spectrum. Because these spectrums are influenced by the particular activity of a user, e.g., standing in a ski line, a microprocessor subsystem of the invention preferably includes means for assessing boundary conditions of the spectrum and for excluding certain conditions from the determination of loft time. Accordingly, if a skier is in a lift line, such conditions are effectively ignored. One boundary condition, therefore, according to an aspect of the invention, includes an elapsed time between the first condition and the second condition that is less than approximately 500 ms; such that events that are within this boundary condition are excluded from the determination of loft time. One other boundary condition, in another aspect, includes an elapsed time between the first condition and the second condition that is greater than approximately five seconds; such that events that are outside this boundary condition are excluded from the determination of loft time. Because these boundary conditions are important in the aspects of the invention which utilize a spectrum of information, the apparatus preferably utilizes a user interface for providing selective external inputs to the microprocessor subsystem and for adjusting the boundary conditions selectively.

4

In still another aspect of the invention, the microprocessor subassembly includes means for determining a pitch of the spectrum by determining a best-fit sine wave to a primary frequency of at least part of the spectrum and means for correlating the pitch to a vehicle speed. Accordingly, the invention can detect spectrum information and correlate that information to a speed of the vehicle. Typically, a higher pitch frequency corresponds to a higher vehicle speed and a lower pitch frequency corresponds to a lower vehicle speed. However, in another aspect, the selected pitch frequency can be calibrated relative to a selected vehicle and speed.

The invention also provides, in another aspect, means for storing information including look-up tables with pitch-to-speed conversions for a plurality of vehicles. This is useful because different vehicles have different associated noise and/or sound spectrums associated with the vehicle. Accordingly, the invention in this aspect includes memory for storing the respective calibration information of the different vehicles (typically in a look-up table format) so that a user can utilize the invention on different vehicles and still determine speed accurately. Specifically, a particular pitch is associated with a particular speed for a particular vehicle; and that association is selectively made by the user.

The vehicles which are preferably used, according to the invention, include (i) a snowboards, (ii) snow skis, (iii) water skis, (iv) skis for ski jumping, and (v) skis for ski flying. However, in certain aspects of the invention, a human vehicle can be used; although the processing power required to accurately process speed and/or loft information in this aspect is significantly increased.

In several aspects of the invention, the microprocessor subassembly includes one or more of the following: means for selectively starting and stopping the acquisition of data by the apparatus; means for responding to an external request to activate the display means; means for responding to an external request to alternatively display the loft time and a speed of the vehicle; means for calculating a speed of the vehicle; means for responding to an external request to display successive records of loft time information; means for responding to an external request to display successive records of speed information; means for determining an average speed; means for determining a total loft time; means for determining a dead time; means for responding to an external request to display information corresponding to an average loft time; means for responding to an external request to display information corresponding to an average speed; means for responding to an external request to display a total loft time; means for responding to an external request to display a dead time; means for responding to an external request to display a distance traveled by the vehicle; means for responding to an external request to display a height achieved by the vehicle off of the surface; and means for responding to an external request to display a real activity time.

The invention also provides certain improvements to sporting vehicles of the type ridden by a user on a surface (e.g., sporting vehicle such as (i) snowboards, (ii) snow skis, (iii) water skis, (iv) skis for ski jumping, and (v) skis for ski flying). The improvements include, in one aspect, a speed sensor having (i) a voltage-measuring circuit including a pair of conductors arranged to contact the surface so that the surface is part of the circuit, and (ii) an electromagnet for selectively generating a magnetic field on the circuit, wherein a voltage generated by the circuit is proportional to a speed of the vehicle. In such an aspect, the microprocessor subsystem determines a speed of the vehicle that is based upon the voltage, and that speed is displayed to a user.

5

The invention also provides certain methodologies. For example, in one aspect, the invention provides a method for determining the loft time of a moving vehicle off of a surface, comprising the steps of: (1) sensing the vehicle leaving the surface at a first time; (2) sensing the vehicle returning to the surface at a second time; (3) determining a loft time from the first and second times, and (4) displaying the loft time to a user of the apparatus.

In still another aspect, the invention provides a method of measuring the amount of "power" a user absorbs during the day. A motion sensor, e.g., a microphone or accelerometer, attaches to the vehicle, preferably pointing perpendicular to the top of the vehicle (e.g., perpendicular to the top surface of the snowboard) so that a measure of acceleration or "force" jarring the user can be made. The data from the motion sensor is integrated over a selected time—e.g., over the time of the skiing day—so that an integrated measure of motion is acquired. By way of example, if the motion sensor is an accelerometer positioned with a sensitive axis arranged perpendicular to the top snowboard surface, then, through integration, an integrated measure of "power" is obtained.

Those skilled in the art should appreciate that the measure can be converted to actual power or similar units—e.g., watts or joules or ergs or Newtons—though the actual unit is not as important as having a constant, calibrated measure of "power" for each user. That is, suppose two snowboarders have such motion sensors on their respective snowboards. If one person goes down a green slope and another down a double-diamond, then the integrated value out of the double-diamond snowboarder will be greater. The units are therefore set to a reasonably useful value, e.g., generic power "UNITS." In one aspect, the power units are set such that a value of "100" indicates a typical snowboarder who skies eight hours per day and on maximum difficult terrain. At the same time, a snowboarder who rides nothing but green beginner slopes, all day, achieves something far less, e.g., a value of "1". In this manner, average skiers on blue, intermediate slopes will achieve intermediate values, e.g., "20" to "50". Other scales and units are of course within the scope of the invention.

The measure of power according to the invention thus provides significant usefulness in comparing how strenuous one user is to another. For example, suppose two users ski only blue, intermediate slopes with the exact same skill and aggressiveness except that one user chooses to sit in the bar for three hours having a couple of cocktails. At the end of an eight hour day—providing the power sensor is activated for the whole day—the skier who skied all eight hours will have a power measurement that is 8/5 that of his cocktail-drinking companion. They can thereafter quantitatively talk about how easy or how difficult their ski day was. As for another example, suppose a third friend skis only double-diamond slopes and he takes four hours out to drink beer. At the end of the day, his power measure may still be greater than his friends depending upon how hard he skied during his active time. He could therefore boast—with quantitative power data to back him up—that he had more exercise than either of his friends even though he was drinking half the day.

The measure of air time, according to the invention, can also be used in a negative sense. That is, speed skiers try to maintain contact with the ground as air time decreases their speed. By monitoring their air time with the invention, they are better able to assess their maneuvers through certain terrain so as to better maintain ground contact, thereby increasing their time.

The measurement of air, speed and power, in accord with the invention, is preferably made via a sensor located on the

6

vehicle, e.g., on the snowboard or ski on which the person rides. As such, it is difficult to see the sensor; so in one aspect the invention provides an RF transmitter in the sensor and a watch, with an RF receiver, located on the wrist of the person. The data—e.g., air, power and speed—is transmitted to the person for easy viewing on the watch. In still other aspects, a memory element in the watch provides for storing selected parameters such as successive records of speed, air and power, or the average "power" spent during the day.

The invention is next described further in connection with preferred embodiments, and it will be apparent that various additions, subtractions, and modifications can be made by those skilled in the art without departing from the scope of the invention

BRIEF DESCRIPTION OF THE DRAWINGS

A more complete understanding of the invention may be obtained by reference to the drawings, in which:

FIG. 1 illustrates a system constructed according to the invention for determining loft and speed of a sporting vehicle carrying the system;

FIGS. 2, 2A and 2B show illustrative uses for the system 10 shown in FIG. 1;

FIG. 3 illustrates a user interface and display suitable for use in the system of FIG. 1;

FIG. 4 is a representative vibrational spectrum, shown illustratively, for calculating "air" or loft time in accord with the invention;

FIG. 5 shows a microphone-based loft sensor constructed according to the invention and which is suitable for use in the system of FIG. 1;

FIG. 6 shows a switch-based loft sensor constructed according to the invention and which is suitable for use in the system of FIG. 1;

FIG. 7 shows a capacitance-based loft sensor constructed according to the invention and which is suitable for use in the system of FIG. 1;

FIG. 8 schematically illustrates electronics, constructed according to the invention, for converting a varying capacitance, e.g., the capacitance derived from the loft sensor of FIG. 7, to information suitable for calculating "air" time;

FIG. 9 schematically illustrates alternative electronics, constructed according to the invention, for converting a varying capacitance, e.g., the capacitance derived from the loft sensor of FIG. 7, to information suitable for calculating "air" time;

FIG. 10 schematically illustrates a microprocessor sub-system constructed according to the invention and which is suitable for use in the system of FIG. 1;

FIG. 11 illustrates one exemplary pitch-detection process, in accordance with the invention, which is used to determine the speed of a vehicle;

FIG. 12 illustrates a Doppler-based approach to sensing speed in accordance with the invention;

FIG. 12A shows a laser-based Doppler speed sensor constructed according to the invention;

FIG. 12B shows an ultrasonic-based Doppler speed sensor constructed according to the invention;

FIG. 13 illustrates an accelerometer-based speed sensor constructed according to the invention and which is suitable for use as both the speed and loft sensors of FIG. 1;

FIG. 14 schematically illustrates process methodology of converting a plurality of acceleration values to speed, in accord with the invention;

7

FIG. 14A schematically illustrates a process methodology of calculating speed, direction, and vehicle height, in accord with the invention, by utilizing the accelerometer-based sensors of the invention;

FIGS. 15 and 15A illustrate a pressure-based speed sensor constructed according to the invention;

FIGS. 16 and 16A illustrate a magnetic/voltage-based speed sensor constructed according to the invention;

FIG. 16B shows relative motions, magnetic field directions, and voltages associated with the sensor of FIGS. 16 and 16A;

FIG. 17 illustrates an improvement to a snowboard in accord with the invention; and

FIG. 18 illustrates one use of the invention for detecting speed, "air," and distance in the sport of ski flying (or ski jumping) in accord with the invention.

FIGS. 19, 19A show one embodiment of the invention for determining speed through charge cookies; and FIG. 19B shows a circuit for coupling with the apparatus of FIGS. 19-19A;

FIGS. 20, 20A show another embodiment of the invention for determining speed through magnetic cookies;

FIGS. 21, 21A show yet another embodiment of determining speed through optical windows, according to the invention;

FIG. 22 shows a schematic view—not to scale—of a skier skiing down a mogul course and of system constructed according to the invention for monitoring two power meters to quantitatively measure mogul skiing performance relative to other skiers;

FIG. 23 shows a power meter constructed according to the invention for measuring activity energy for various sportsmen;

FIGS. 24-26 illustrate various, exemplary signals obtainable the power meter of FIG. 23;

FIG. 27 shows a technique for measuring height, in accord with the invention, such as for a skier's height;

FIGS. 28, 29 show alternative "air" measuring techniques, according to the invention; and

FIG. 30 shows a ski-to-watch transmitting system, constructed according to the invention, for informing a skier of performance factors at a watch rather than on the ski.

DETAILED DESCRIPTION OF ILLUSTRATED EMBODIMENTS

FIG. 1 illustrates a system 10 constructed according to the invention. A microprocessor subsystem 12 controls the system 10 and connects to a user interface 14, a display 16, speed sensor 18 and loft sensor 20. A power supply 22, e.g., a battery, provides power to the system 10 and connects to the components 12, 14, 16, 18 and 20 via appropriate electrical interconnections (not shown). The microprocessor subsystem 12 includes memory 13 for storing data acquired by the system 10.

The system 10 is incorporated into a relatively small housing, shown by the outline 24. The housing 24 is preferably arranged to protect the components 12, 14, 16, 18 and 20 from the elements of nature—such as rain, snow, sand and dust, each of which is expected during the ordinary course of usage on a ski slope and/or mountain bike trail. In addition, the housing 24 is attachable to a vehicle, such as a ski or mountain bike, by means such as a glue or a mechanical mount, e.g., screws. Alternatively, the housing (and hence the system 10) is incorporated integrally with the

8

vehicle, such as inside a ski, such that only the display 16 and user interface 14 are visible and accessible.

Briefly, the invention shown in FIG. 1 operates as follows. The housing 24 is attached or mounted to a sporting device, such as a ski or mountain bike, such that a user of the ski or mountain bike can access the system 10. During motion of the ski or mountain bike, the speed sensor 18 sends velocity information (over communication line 11a) to the microprocessor subsystem 12; while the loft sensor 20 sends loft or "air" time information (over communication line 11b) to the microprocessor subsystem 12. The speed information and loft time information are processed by the microprocessor subsystem 12 to quantify actual speed, e.g., in miles per hour, and actual loft time, e.g., in seconds. The actual speed and loft time are thereafter stored in internal memory 13 until, at least, the speed and time data are accessed by a user of the system 10. Upon access through the user interface 14 (communicating with the microprocessor subsystem 12 via communication line 11c), a user of the system 10 can command the display of the speed and loft time data (sent across communication line 11d) on the display 16 in order to evaluate his or her performance in the sporting activity.

In an alternative embodiment, the speed and loft information can be stored prior to processing by the microprocessor subsystem 12; and later post-processed for display on the display 16 when commanded by a user of the system 10. Such an embodiment may be useful to conserve energy and to perform calculations to quantify the speed and loft data in a "batch" mode, such as known to those skilled in the art.

The system 10 of FIG. 1 preferably includes both of the speed sensor 18 and loft sensor 20; although it is not necessary for both sensors to be present in accord with the invention. Rather, in certain embodiments of the invention, only the loft sensor 20 is present within the system 10; and in certain other embodiments of the invention, only the speed sensor 18 is present within the system 10. Accordingly, in these embodiments, only the loft data or speed data, respectively, are available to a user of the system because the sensor which measures the information is absent.

FIGS. 2, 2A and 2B show typical uses of the system 10 illustrated in FIG. 1. In particular, FIG. 2 shows the system 10 mounted onto a ski 26. As is normal, the ski 26 is mounted to a skier 28 (for illustrative purposes, the skier 28 is only partially illustrated), via a ski boot 30 and binding 30a, and generally descends down a ski slope 32 with a velocity 34. Accordingly, one use of the system 10 is to calculate the peak speed of the ski 26 (and hence the skier 28) over a selectable period of time, e.g., during the time of descent down the slope 32.

Another use of the system 10 of FIG. 1 is to calculate the loft, or "air" time of the ski 26 (and hence the user 28) during the descent down the slope 32. Consider, for example, FIG. 2A, which illustrates the positions of the ski 26' and skier 28' during a lofting maneuver on the slope 32'. The ski 26' and skier 28' speed down the slope 32' and launch into the air 36 at position "a," and later land at position "b" in accord with the well-known Newtonian laws of physics. The system 10 calculates and stores the total "air" time that the ski 26' (and hence the skier 28') experience between the positions "a" and "b" so that the skier 28' can access and assess the "air" time information.

FIG. 2B illustrates the system 10 mounted onto a mountain bike 38. FIG. 2B also shows the mountain bike 38 in various positions during movement along a mountain bike race course 40 (for illustrative purposes, the bike 38 is

shown without a rider). At one location "c" on the race course 40, the bike 38 hits a dirt mound 42 and catapults into the air 44. The bike 38 thereafter lands at location "d." As above, the system 10 provides information to a rider of the bike 38 about the speed attained during the ride around the race course 40; as well as information about the "air" time between location "c" and "d."

USER INTERFACE AND DISPLAY

With further reference to FIG. 1, the display 16 can be one of any assortment of displays known to those skilled in the art. For example, liquid crystal displays (LCDs) are preferred because of their low power draw (for example, LCDs utilized in digital watches and portable computers are appropriate for use with the invention). Other suitable displays can include an array of light emitting diodes (LEDs) arranged to display numbers.

FIG. 3 illustrates a user interface 50 and display 52 constructed according to the invention and which are suitable for use, respectively, as the interface 14 and display 16 of FIG. 1. Outline 54 illustrates the outline of a system constructed according to the invention, e.g., the housing outline 24 of the system 10 of FIG. 1. In order for a user of the system to access information within the system, user interface 50 includes control buttons. For example, with reference to FIG. 3, one embodiment of the user interface 50 includes a start/stop button 58, a display-operate button 60, and a speed/loft toggle button 62. These buttons operate as follows:

A user presses the start/stop button 58 at the start of activity—such as at the start of skiing down a slope or biking down a trail—and presses the button 58 at the completion of activity to cease the acquisition of data (as described in more detail below).

A user pressed the display-operate button 60 to activate the display 52 so that a user can view recorded information from the sporting activity on the display 52. Accordingly, the display 52 is normally OFF—and not drawing power from the associated power source (e.g., the power source 22 of FIG. 1)—and is turned ON only when a user activates the display-operate button 52. The ON and OFF display conditions are preferably obtained in one of two ways: in one embodiment of the invention, the display 52 automatically turns OFF after a preselected time through the control of the microprocessor subsystem 12 of FIG. 1; or, in an alternative embodiment, the display 52 remains activated until a user again presses the display-operate button 60.

A user presses the speed/loft toggle button 62 to sequentially command the display, respectively, of information about speed and loft time. For example, if the display 52 currently displays speed information, a user can instead command the display of loft time information by pressing the speed/loft toggle button 62 once. If, on the other hand, the display 52 currently displays loft information, a user can instead command the display of speed information by pressing the speed/loft toggle button 62 once. Preferably, one portion 64 of the display denotes whether speed or loft information is being displayed. For example, as illustrated, a "L" letter denotes that loft information is being displayed. An "S" letter likewise denotes that speed information is being displayed. For illustrative purposes, the "air" time is also displayed in FIG. 3 as 2.46 seconds, which represents the "air" time of a typical ski jump.

It is important to note that one embodiment of the invention does not include the speed/loft toggle button 62

because, as noted earlier, certain embodiments of the invention do not include both the speed sensor and loft sensor. In such an embodiment, it is unnecessary to include a toggle button 62.

The display 52 of FIG. 3 also shows another feature of the invention, namely that a system constructed according to the invention preferably calculates and stores successive records relating to speed and loft information relative to a user's activity. For example, a skier may catch "air" time more than once during a given activity; and the system of the invention can store successive loft times for access by the user. Most often, the peak "air" time is displayed, by default. However, certain users wish to evaluate successive loft time information and, accordingly, the system 10 of FIG. 1 preferably determines and stores the successive information (described in greater detail below). A user can access the successive loft time information by toggling a combination of the buttons 58–62, such as known to those skilled in the art (e.g., a combination of holding one button down while pressing another button); or by including yet another button 66 on the user interface 50. A display portion 68 of the display 52 shows a number corresponding to the sequential information on display. For example, the illustrated "1" number means that the highest "air" time record is currently being displayed; while a number greater than one means that a loft time other than the highest loft time is being displayed. In addition, the highest number displayed within the portion 68 refers to the total number of "air" times for the selected activity period (thus for example a user can determine the total number of jumps achieved for a given day).

In still another embodiment of the invention, successive speed information can be displayed much the way successive "air" time information is stored and displayed, described above. To view the speed information, the speed/loft toggle button 62 is pressed once to display "S" in the display portion 64, and a user can toggle button 66 to view the successive speed records as denoted by the number in display portion 68. However, this information is not deemed very useful except under a very few circumstances—since a user generally moves with some velocity during a given activity—and thus, generally, the peak speed achieved during a given activity is normally displayed on the display 52 when commanded by the speed/loft toggle button 62.

In an alternative embodiment, a button 67 is used to alter the modes of the system so that other information such as average "air" time may be calculated and displayed by the invention. For example, FIG. 3 illustrates a display portion 69 that shows a letter "A," corresponding to information relating to averages. Thus, for a particular sporting activity, a user can press button 69 to display "air" time as a running average of all the successive "air" times (in such an embodiment, the display portion 68 is preferably OFF because the information displayed in portion 68 refers to successive peak information). To access the peak "air" time information, the button 67 is pressed once again, causing the microprocessor subsystem 12 to change the display information from integrated average values to peak values (accordingly, the display portion 69 preferably shows a "P" to identify to the user that peak information is being displayed; and the display portion 68 is preferably ON in this "peak" mode to denote which successive record is being displayed). To access integrated information—e.g., the total "air" time for a given day—the button 67 is pressed once again, causing the microprocessor subsystem 12 to show the integrated "air" or speed information (depending on the toggle of the speed/loft toggle button 62). Integrated values are preferably displayed by indicating to the user a "T" (for total) in the display portion 69.

11

It should be dear to those skilled in the art that other buttons and/or combinations of buttons can be incorporated within the user interface 50 within the scope of the invention. The microprocessor subsystem 12 of FIG. 1 stores much information during the sporting activity and which can be converted to different forms, e.g., averages, peaks, and totals. In accord with the invention, different buttons and combinations of buttons can be used to access all of the available information. In addition, other information can be denoted, for example, within the display portion 69 to identify the different types of information available within the system.

For example, yet another form of information which may be of interest to sporting persons is the "dead" time, i.e., the time that the person is not skiing or biking during the day. For example, a person who hangs out in the bar during part of the afternoon will not have a high efficiency factor for actual ski time as compared to the available ski time. This efficiency information is available in accord with the invention because the microprocessor subsystem 12 of FIG. 1 preferably includes a dock element (readily known to those skilled in the art) for indicating processed time over a selectable period (the microprocessor subsystem 12 can in fact include a 24-hour clock element, much the way a digital wrist-watch includes 24-hour information). Accordingly, a user can start the system 10 of FIG. 1 at the beginning of the day by pressing the start/stop button 58, and stop the collection of data at the end of the day by again pressing the start/stop button 58. The microprocessor subsystem 12 keeps track of the elapsed time between the start and stop of the system (i.e., the selectable time period), thereby providing means for determining the user's "dead" time for the day. That is, the microprocessor subsystem 12 calculates "dead" time by intelligently calculating the total time lapse within which a vibrational noise spectrum (described in more detail below in connection with FIG. 4) is present within the selectable time period; and dividing that total time lapse by the selectable time period to obtain a ratio of the real activity time versus the user's dead time (for example, a ratio of 80% means that the sporting person skied for 80% of the day). Dead time information is thereafter easily determined by subtracting 80% from 100%, to get 20% dead time. The dead time information is shown, for example, by toggling the button 67 to a dead time mode, denoted as "D," in the display portion 69, and displaying the dead time as a percentage in the display 52. Alternatively, the real activity time is displayed as a percentage in the display 52 by toggling the button 69 until "R" shows up in the display portion 69.

LOFT SENSOR

With further reference to FIG. 1, the loft sensor 20 may be constructed by several known components. Preferably, the sensor 20 is either an accelerometer or a microphone assembly. Alternatively, the sensor 20 may be constructed as a mechanical switch that detects the presence and absence of weight onto the switch. Each of these alternatives is described below.

Loft Sensor: Accelerometer Embodiment

An accelerometer, well known to those skilled in the art, detects acceleration and provides a voltage output that is proportional to the detected acceleration. Accordingly, the accelerometer senses vibration—particularly the vibration of a vehicle such as a ski or mountain bike—moving along a surface, e.g., a ski slope or mountain bike trail. This

12

voltage output provides an acceleration spectrum over time; and information about loft time can be ascertained by performing calculations on that spectrum. Specifically, the microprocessor subsystem 12 of FIG. 1 stores the spectrum into memory 13 and processes the spectrum information to determine "air" time.

FIG. 4 illustrates a graph 70 of a representative vibrational spectrum 72 that is stored into the microprocessor subsystem 12 (FIG. 1). The vertical axis 74 of the graph 70 represents voltage; while the horizontal axis 76 represents time. At the beginning of activity 77—such as when a user of a system constructed according to the invention presses the start/stop button 58 (see FIG. 3)—the loft sensor 20 of FIG. 1 begins acquiring data and transferring that data to the microprocessor subsystem 12 via communication lines 11b. This data appears highly erratic and random, corresponding to the randomness of the surface underneath the vehicle (e.g., ski or vehicle). At time "t1," the user of the system lofts into the air, such as illustrated as location "a" in FIG. 2A and as location "c" in FIG. 2B; and lands some time later at time "t2," such as illustrated as location "b" in FIG. 2A and as location "d" in FIG. 2B. The vibrational spectrum between t1 and t2 is comparatively smooth as compared to the spectrum outside this region because the user's sporting vehicle (e.g., the ski or mountain bike) is in the air and is not therefore subjected to the random vibrations of the road or ski slope. Accordingly, this relatively smooth spectrum between t1 and t2 can be readily discerned from the rest of the spectrum by the microprocessor subsystem 12 and evaluated for "air" time: specifically, "air" time is t2-t1.

FIG. 4 also shows that the spectrum stops at the end 78 of the sporting activity, such as when the user of the system again presses the start/stop button 58, FIG. 3.

In one embodiment of the invention, a user can simply start the system 10 of FIG. 1 at the beginning of the day, by toggling the start/stop button 58, and stop the system 10 at the end of the day, by again toggling the start/stop button 58. The issue here, however, is that there may be apparent "air" times between the starting and stopping of the system which is not, in fact, the "air" time of interest. For example, standing in line at a ski lift represents a period within which the spectrum 72 appears smooth, and might be mistaken for "air" time. Accordingly, the microprocessor subsystem 12 of the invention preferably includes process boundary conditions within which "air" time will be excluded. For example, one practical boundary condition is: if the spectrum between any given "t1" and "t2" time (FIG. 4) is greater than five seconds, then exclude that time from memory as actual "air" time. Thus, each time the skier stands in line, that smooth spectrum which is being processed by the system is ignored.

Another boundary condition, for example, concerns the type of skier using the system. Some skiers often make quick jump turns down the mountain. These would normally show up as mini "air" times. Thus, in accord with another aspect of the invention, another boundary condition is: if the spectrum between any given "t1" time and "t2" time (FIG. 4) is less than 500 ms, then exclude that time from memory as actual "air" time. Accordingly, each jump turn will not be included in the total "air" time for the day, as is expected by users of the system.

The invention preferably includes an adjustment mechanism to adjust these boundary conditions (e.g., the five seconds maximum and the 0.5 second minimum) so that such conditions can be adjusted and optimized to individual users. Accordingly, in one embodiment of the invention, certain of the buttons 58-67 of FIG. 3 can be used in

13

combination to set the maximum and minimum boundary conditions. Alternatively, one or more additional buttons can be included within the user interface of FIG. 3 to provide the adjustment mechanism.

Another embodiment of the invention internally resets the start/stop button 58 when the system senses the lack of spectral information for a preselected period of time. Thus, after the preselected period, the system has an automatic time-out, resulting in the microprocessor subsystem 12 resetting itself as if the start/stop button 58 were pushed.

Accelerometers are commercially available and are relatively cheap items. They are also small, so that all of the components 12, 14, 16 and 20 may easily fit within a small, lightweight housing. Suitable accelerometers include those accelerometers shown and described in connection with FIGS. 13, 14 and 14A.

Loft Sensor: Microphone Embodiment

A microphone, also well known to those skilled in the art, detects sound waves and provides a voltage output that is responsive to the detected sound waves. Accordingly, a microphone, like the accelerometer, senses the vibration of a vehicle, such as a ski or mountain bike, moving along a surface, e.g., a ski slope or mountain bike trail. By way of analogy, consider putting one's ear flat onto a desk and running an object across the desk. As one can readily determine, the movement of the object on the desk is readily heard in the ear. Likewise, a microphone as the loft sensor 20 readily "hears" the vibrational movements of the vehicle on the surface. Therefore, like the aforementioned accelerometer, a vibrational spectrum such as shown in FIG. 4 is generated by the microphone loft sensor during a user's sporting activity. As above, the microprocessor subsystem 12 utilizes the spectrum to determine "air" time.

Like accelerometers, microphones are also commercially available and are relatively cheap. They are also small, so that all of the components 12, 14, 16 and 20 may easily fit within a small, lightweight housing.

FIG. 5 illustrates one embodiment of a microphone assembly 80 suitable for use with the invention. Specifically, a system 82 constructed according to the invention mounts, for example, to a ski 84 (for illustrative purposes, only the loft sensor portion 80 and microprocessor subsystem 81 are shown as part of the system 82 even though other components such as the display and user interface are present within the system 82). The microphone assembly 80 preferably includes a tube portion 86 to funnel the sound waves 88 coming from the ski surface 90 to the microphone element 92, e.g., a piezoelectric element known to those skilled in the art. During operation, the vibrational motion caused by the ski's interaction with the surface underneath the ski generates the sound waves 88 detected by the element 92, which converts the sound waves to voltages. These voltages are sampled and stored in the microprocessor subsystem 12 so that the information can be processed to extract the "air" information.

Depending on the sensitivity of the accelerometers and microphone assemblies, described above, it is feasible to attach the system of the invention directly to a user of the system as opposed to the vehicle. The vibrational or sound information is transmitted through the user to some degree while the user is on the ground, and such information can be used, as above, to calculate "air" time. Accordingly, one embodiment of the invention includes a system which measures "air" time that mounts directly to a user rather than to the vehicle, e.g., a ski.

14

Loft Sensor: Weight Switch Embodiment

In still another embodiment of the invention, the sensor 80 of FIG. 1 can be a switch that rests below the boot of the ski, e.g., the boot 30 of FIG. 2, and that senses pressure caused by the weight of the user within the boot. That is, when the skier is on the ground, the boot squeezes the switch, thereby closing the switch. The closed switch is detected by the microprocessor subsystem 12 (FIG. 1) as a discrete input. When a skier jumps into the air, the switch opens up by virtue of the fact that relatively no weight is on the switch; and this opened switch is also detected and input into microprocessor subsystem 12. The microprocessor subsystem 12 will count at known time intervals (clock rates) for the duration of the opened switch, corresponding to the jump, and will record how long the jump lasts.

As described in connection with FIG. 3, the "air" time may be recorded as a single jump, or recorded as a successive list of jumps. In addition, the "air" time can be summed or integrated into a running total, such as described above.

FIG. 6 illustrates the manner in which one switch is formed, in accord with the invention (for illustrative purposes, the drawing of FIG. 6, like most of the drawings herein, are not to scale; and further shows disproportionate sizes of elements of the invention at least). A boot 100 (e.g., the ski boot 30 of FIG. 2) rests on top of a compressible material 102, e.g., foam, that includes a switch 104. When the user steps on the compressible material 102, the compressible material 102 compresses and causes the switch 104 to close, completing the circuit 106 (for illustrative purposes, the circuit 106 is shown simply as a switch 104, battery 108 and resistor 110; and the circuit 106 is shown externally when in fact the circuit is within the system of the invention and in communication with the microprocessor subsystem 12). When the switch 104 is closed, the circuit is in an ON condition, and when the switch 104 is not closed, the system is in an OFF condition. Accordingly, the microprocessor subsystem 12 senses the ON and OFF conditions to calculate "air" time. Specifically, the time between an OFF condition and an ON condition can be used to determine "air" time.

Another embodiment of the invention which is suitable for use as the loft sensor 20, FIG. 1, includes a pad that is placed under the skier's boot and that changes capacitance as a function of a change of applied pressure. For example, consider FIG. 7 (again with illustrative ski boot 100) which shows a compressible material 112 and a capacitance-changing element 114 that changes capacitance under varying applied pressures. This capacitance-changing element 112 is connected in circuit 116, including the illustrative battery element 118 and resistor 120, with the system of the invention such that its capacitance is converted to a digital signal by conditioning electronics, such as shown in FIG. 8. As above, the circuit of FIG. 7 is shown illustratively and without the other necessary components (e.g., the microprocessor subsystem) of the invention. Those skilled in the art understand that the components 112, 114, 115, 116, 118 and 120 connect integrally with a system (e.g., the system 10 of FIG. 1) constructed according to the invention.

By way of background, a capacitor consists of two parallel plates separated by a dielectric material. The capacitance is directly proportional to the cross sectional area of the plates and inversely proportional to the distance between the plates. When the dielectric is the compressible material 112, FIG. 7, then the pressure applied to the material 112 changes the distance between the plates 115a, 115b of the capacitance-changing element 114, thereby proportionately increasing the capacitance.

15

FIG. 8 shows a monostable multivibrator 122, e.g., a NE555, in accord with the invention which converts the varying capacitance (illustrated as portion 124) from the capacitance-changing element 114 of FIG. 7 to information suitable for calculating "air" time. A resistor 126 connects in circuit with the portion 124 and the multivibrator 122. The output pulse train 128 is directly dependent on the product of the resistance "R" and variable capacitance "C". The resistance R may be fixed while the capacitance C is dependent on the pressure exerted on the pad 112 thus shifting the frequency of a pulse train 128. The pulse train 128 repetition rate is indicative of the value of capacitance of 124. When the pulse train 128 repetition rate increases the value of C 124 has decreased and the skier's boot is applying less pressure on the pad 112. This event marks the beginning of the "air time" measurement. When the pulse train 128 repetition rate decreases, meaning a sudden increase of capacitance, the boot is now applying greater pressure on the ski, signifying the end of the "air" time measurement. The length of time that the pulse train 128 remains at the higher repetition rate is equal to the amount of time the ski is off the ground. That amount of time is the loft or "air" time.

Alternatively, and such as shown in FIG. 9, the change in capacitance can be used in a filter which passes a pulse train during low capacitance levels (no boot pressure) and which filters out the pulse train during high capacitance events (high boot pressure). For example, a capacitance-changing element 130 (e.g., the capacitance-changing circuit 116 of FIG. 7) connects to the input of a Schmidt Trigger CMOS gate 133 and ground. A pulse generator 131 connects through a fixed resistor R 132 to the capacitance-changing element 133 and the Schmidt Trigger CMOS gate 133. The pulse generator 131 produces a steady pulse train 134. When the capacitance changing element 130 is at a high capacitance, corresponding to a high boot pressure meaning that the ski is on the ground, the combination of the fixed resistance R 132 and the capacitance of the capacitance-changing element 130 absorbs the pulse train and the output of the Schmidt Trigger CMOS gate 133 is constant. On the other hand, when the skier takes flight, the capacitance of the capacitance-changing element 130 is low, thus allowing the pulse train 134 to pass through to the Schmidt Trigger CMOS gate 133 input. The output of the Schmidt Trigger CMOS gate 133 in this latter case toggles at the same rate as the pulse train 131, thereby identifying a condition of "air" time. A discrete input is thus used by the processor to sample for the existence of the pulse train to calculate "air" time.

MICROPROCESSOR SUBSYSTEM

The microprocessor subsystem 10 of FIG. 1 can include a microcontroller element, a microcontroller element with reduced functionality to conserve power, or a microprocessor element with associated memory and logic to perform the requisite calculations of the invention, including the processing power to drive the display 16 and user interface 14.

Preferably, however, the microprocessor subsystem 12 is constructed by several known components, such as shown in FIG. 10. FIG. 10 shows microprocessor subsystem 150 constructed according to the invention and including a Central Processing Unit (CPU) 152, memory 154, interface electronics 156, and conditioning electronics 158. The user interface 160, such as the interface 14 of FIG. 1, and including the button inputs of FIG. 3, connects to the subsystem such as shown and directly to the conditioning electronics 158. The display 162, such as the display 16 of

16

FIG. 1, preferably connects to the subsystem such as shown and directly to the CPU 152.

The CPU 152 includes a microprocessor 152a, Read Only Memory (ROM) 152b (used to store instructions that the processor may fetch in executing its program), Random Access Memory (RAM) 152c (used by the processor to store temporary information such as return addresses for subroutines and variables and constant values defined in a processor program), and a master dock 152d. The microprocessor 152a is controlled by the master clock 152d that provides a master timing signal used to sequence the microprocessor 152a through its internal states in its execution of each processed instruction. The dock 152d is the master time source through which time may be deduced in measuring velocity or air time (for example, to determine the elapsed time from one event to another, such as the lapsed time "t1" to "t2" of FIG. 4, the clock rate provides a direct measure of time lapse).

The microprocessor subsystem 150, and especially the CPU 152, are preferably low power devices, such as CMOS; as is the necessary logic used to implement the processor design.

The subsystem 150 stores information about the user's activity in memory. This memory may be external to the CPU 152, such as shown as memory 154, but preferably resides in the RAM 152c. The memory may be nonvolatile such as battery backed RAM or Electrically Erasable Programmable Read Only Memory (EEPROM). External signals 164 from the speed and/or loft sensors, e.g., the speed sensor 18 and loft sensor 20 of FIG. 1, are connected to the conditioning electronics 158 which filters, scales, and, in some cases, senses the presence of certain conditions, such as zero crossings. This conditioning essentially cleans the signal up for processing by the CPU 152 and in some cases preprocesses the information. These signals are then passed to the interface electronics 156, which converts the analog voltage or currents to binary ones and zeroes understood by the CPU 152.

The invention also provides for intelligence in the signal processing, such as achieved by the CPU 152 in evaluating historical data. For example, "air" time may be determined by the noise spectra that changes abruptly, such as indicating a leap, instead of a noise spectra representing a more gradual change that would occur for example when a skier slows to a stop. As previously noted, a minimum quiet time is required, in certain embodiments of the invention, to differentiate between "air" time and the natural motions associated with turning and skiing (e.g., jump skiing). Further, in other certain embodiments, a maximum time is also programmed to differentiate "air" time from an abrupt stop, such as standing in a lift line.

SPEED SENSOR

In accord with the invention, if speed is calculated within the system, the speed sensor 118 of FIG. 1 can take one of several forms, including: (1) a pitch detection system that detects the "pitch" of the vibrational spectrum and that converts the pitch to an equivalent speed; (2) a laser-based or sound-based Doppler-shift sensor; (3) an accelerometer-based speed sensor; (4) a pressure-based speed sensor; and (5) a voltage-resistance sensor

It should be noted that in either of the speed or loft sensors, it may be preferable to incorporate state machine logic within the sensor in order to pre-process the data for the microprocessor subsystem. Thus, in accord with the invention, processing logic such as described herein in

17

connection with the microprocessor subsystem can be incorporated, at least in part, within one or both of the speed and loft sensors. Because of the complexity of the speed sensor, such preprocessing power is more appropriately within the speed sensor.

Speed Sensor: Pitch Detection

In accord with this embodiment, no separate speed sensor element, e.g., the sensor **18** of FIG. **1**, is required. Rather, the vibrational spectrum that is generated by the loft sensor **20**, and particularly the accelerometer or microphone embodiment discussed in connection with FIG. **4**, will be used to determine the pitch of the vibration and, thereby, the equivalent speed. By way of example, note that a skier generates a scraping sound on hard-packed snow and ice. When the skier changes velocity, that scraping sound changes in pitch. The spectrum shown in FIG. **4** outside the $t1/t2$ region (but within the "start" and "end" region) is, effectively, that pitch. By calibrating the microprocessor subsystem **12** to associate one pitch as one velocity, and so on, the speed of the vehicle (e.g., ski and mountain bike) may be determined by spectral content.

In accord with the invention, one method for determining the "pitch" of the spectrum outside the $t1/t2$ loft region of FIG. **4** (and within the start/stop time) is to determine the "best fit" sine wave to the vibrational spectrum data. This sine wave will have a frequency, or "pitch" that may be quantified and used to correlate velocity.

This spectral content may be determined, in part, by the conditioning electronics **158** of FIG. **10** such to determining rise times to infer a bandwidth of the information. The conditioning electronics **158** and/or CPU **152** can also measure the time between successive zero crossings, which also determines spectral content.

For example, FIG. **11** illustrates a spectrum **166** generated from a sensor such as a sensor **18** or **20** (FIG. **1**), or **82** (FIG. **5**), or **202a-202d** (FIG. **13** below). The spectrum **166** thus represents an acceleration spectrum or sound spectrum such as described herein. The microprocessor subsystem **12** of FIG. **1** evaluates the spectrum **166** and generates a best-fit sine wave **167** to match the primary frequency of the spectrum **166** over time. FIG. **11** shows illustratively a situation where a vehicle, such as a ski, moves slowly at first, corresponding to a lower sine-wave frequency, then faster, corresponding to a higher frequency sine wave, and then slower again. This pitch transition is interpreted by the microprocessor subsystem (e.g., the subsystem **12** of FIG. **1**) as a change of speed. Specifically, the microprocessor subsystem of the invention is calibrated in this embodiment to associate a certain frequency with a certain speed; and speed is thus known for the variety of pitches observed during an activity, such as illustrated in FIG. **11**.

It should be noted that the pitch information is surface dependent (and vehicle dependent). That is, a ski-over-snow-speed-spectrum has a different spectrum than a bicycle-over-ground-spectrum. Accordingly, different calibrations must be made for different vehicles and speeds, in accord with the invention. Further, certain spectrums may actually decrease in frequency as speed increases; which also must be calibrated to obtain the correct speed information. These calibrations are typically programmed into the microprocessor subsystem memory, e.g., the memory **13** of subsystem **12** of FIG. **1**. Further, in certain embodiments of the invention, the system stores different spectrum calibrations for different activities so that a user can move the system from one sport to another. Accordingly, one or more

18

buttons such as the buttons **58-67** of FIG. **3** are introduced to the user interface, such as known to those skilled in the art, in order to selectively access the different spectrum calibrations.

Seed Sensor: Doppler-based

It is well known that Doppler radar is used by police vehicles to detect speed. In accord with this embodiment of the invention, the same principles apply to the measurement of speed of the sporting vehicle. For example, consider FIG. **12**.

FIG. **12** shows a representative ski **170** (partially shown) with a Doppler-based sensor **172** mounted thereon (for illustrative purposes, the Doppler-based sensor is shown without the other elements of the system, such as the user interface and microprocessor). The sensor generates an electromagnetic beam **174**, such as a laser beam, to bounce off the ground **176** (e.g., the ski slope) while the user of the system conducts the activity (e.g., skiing). The electromagnetic beam **174** is reflected off the ground by particles **178** which scatter at least a portion of the energy back to the sensor **172** along approximately the same path. Because the ski **170** is in motion, the returned energy is at a slightly different frequency from the outgoing frequency; hence the Doppler shift, which is a measurable quantity. Note that the sensor **172** must be arranged to generate a beam along the side (or in front or back of) the ski in order to "see" the ground **176**.

The energy beam **174** is generated in one of two general ways: by a laser diode (to generate a laser beam) or by a piezoelectric transducer (to produce an ultrasonic beam). FIG. **12a**, for example, shows a sensor **172'** comprising a laser diode **180**. The diode **180** generates a laser beam **174'** which is reflected by the particles **178'** back to the sensor **172'**. A small beam-splitting mirror **182** reflects part of the returned beam to a detector **184** which is connected under the overall control of the microprocessor subsystem **186**, e.g., the subsystem **12** of FIG. **1** (for illustrative purposes, the other elements of the system of the invention, e.g., the user interface, are not shown in FIG. **12a**). The subsystem **186** evaluates the frequency difference between the outgoing beam from the diode **180** and the returned frequency from the detector **184**. The frequency difference is readily converted to speed that is displayed on the display, e.g., the display **16** of FIG. **1**.

Likewise, FIG. **12b** shows a sensor **172"** comprising a piezoelectric transducer **190** which generates an ultrasonic beam **174"** that reflects from particles **178"** back to the piezo transducer **190**, which is connected under the overall control of the microprocessor subsystem **192**, e.g., the subsystem **12** of FIG. **1** (for illustrative purposes, the other elements of the system of the invention, e.g., the user interface, are not shown in FIG. **12b**). The microprocessor subsystem **192** generates a voltage at a set frequency to drive the piezoelectric transducer **190**, to thereby generate the beam **174"**. The reflected Doppler-shifted beam returns through the transducer **190** (alternatively, through another piezo transducer (not shown)) and generates a voltage at the frequency of the reflected beam. The subsystem **192** evaluates the frequency difference between the outgoing ultrasonic beam **174"** and the returned frequency. As above, the frequency difference is readily converted to speed (via a conversion technique that is known to those skilled in the art) that is displayed on the display, e.g., the display **16** of FIG. **1**.

A Doppler system such as described can additionally provide height information. That is, by sweeping the fre-

quency through various frequencies, the signal frequency mix can be monitored to determine altitude relative to the direction of the antenna lobes. Preferably, therefore, there are two antennas: one to perform Doppler speed, with high spatial accuracy in the antenna lobe so that speed is achieved, and another antenna to provide a lobe that roughly covers the ground area in about a 60 degree cone under the user so as to achieve first-return distance measurement. That is, with reference to FIG. 27, a doppler system 648 placed relative to a skier 650 on a ski 652 should adequately cover the ground 654 so as to provide the correct measure of height "h." A cone 656 of adequate angle \hat{O} (e.g., 25–70 degrees in solid angle) provides such a coverage. The Doppler antenna signal lobe fills the cone 656 so as to determine first return height "h" from the correct orientation of the ski 652.

Loft Sensor: Accelerometer Based

Modern navigation systems utilize a plurality of accelerometers to determine speed and direction. Particularly complex military systems, for example, utilize three translational and three rotational accelerometers to track direction and speed even during complex angular movements and at extremely high velocities.

In accord with the invention, a similar plurality of accelerometers is used to determine speed. However, unlike military systems, one goal of the invention is to track speeds of sporting vehicles (e.g., a ski) that generally travel in one direction, namely forward. Therefore, the complexity of the accelerometer package is reduced since the orientation of the sensor may be fixed to the vehicle; and fewer than six accelerometers can be used to determine speed.

Accelerometers are well-known to those skilled in the art. They include, for example, translational and rotational accelerometers. FIG. 13 illustrates a speed sensor 200 constructed according to the invention and which includes a plurality of accelerometers 202a–202d. The accelerometers 202a–202d sense various accelerations in their respective axes (accelerometers sense acceleration along a predefined axis, translational or rotational), and each of the outputs from the accelerometers are input to the microprocessor subsystem 204, e.g., the subsystem 12 of FIG. 1, via communication lines 206a–206d. The orientation of the sensitive axis of each accelerometer 202a–202d is stored in the microprocessor subsystem 204 so that a particular acceleration in one axis is properly combined with acceleration values in other axes (as described in more detail below in connection with FIGS. 14 and 14a).

One key point that must be addressed with the accelerometer-based approach: gravity has a huge effect on the accelerometer signals; and gravity must be compensated for in order to achieve reasonable speed accuracy. Therefore, one or more of the accelerometers 202a–202d are used to determine and measure the force or gravity relative to the angle of the vehicle (e.g., the ski) so that gravity may be compensated for by the subsystem 204. Specifically, when the sensor 200 is pointed either downhill or uphill, gravity tends to reduce or increase the measured acceleration output; and that reduction or increase must be adjusted for or else the conversion from acceleration to speed (i.e., the integral of acceleration over time) will be next to useless. Accordingly, the orientations of the accelerometers 202a–202d relative to their respective sensitive axes must be known by the subsystem 204 in order to compensate for the acceleration of gravity, which is generally perpendicular to the motion of the vehicle, but which has a component acceleration in the direction of movement when the vehicle is pointed downwards or upwards.

It should be dear to those skilled in the art that fewer, or greater, numbers of accelerometers are within the scope of the invention, so long as they collectively determine speed. In effect, the fewer number of accelerometers results in reduced accuracy; not reduced functionality. Rather, in an ideal situation, one accelerometer can be used to detect speed; which is the integral of the acceleration over time. Further, a double integration over the same period provides distance; and, therefore, the invention can also provide distance in at least one embodiment of the invention.

It should also be noted that any of the accelerometers 202a–202d of FIG. 13 can be used, in accord with the invention, as the loft sensor 20 of FIG. 1 and without a separate component to measure "air" time. This is because each of the accelerometers 202a–202d generate a spectrum such as described in connection with FIG. 4. Accordingly, one or more of the accelerometers 202a–202d can be used to determine "air" time, described above, without the need for a separate loft sensor.

FIG. 14 schematically illustrates process methodology, according to the invention, which converts a plurality of acceleration inputs to speed. For example, when a plurality of six accelerometers (e.g., similar to the accelerometers 202a–202d of FIG. 13) are connected to a microprocessor subsystem such as the subsystem 150 of FIG. 10, the process methodology of the invention is preferably shown in FIG. 14. Specifically, six accelerometers are connected with various sensitive orientations to collect pitch 207a, yaw 207b, roll 207c, surge 207d, heave 207e, and sway 207f accelerations. These accelerations are conditioned by the conditioning electronics 158' through the interface electronics 156' and CPU 152' to calculate speed, such as known to those skilled in the art of navigational engineering (for example, *Gyroscopic Theory, Design, and Instrumentation* by Wrigley et al., MIT Press (1969); *Handbook of Measurement and Control* by Herceg et al, Schaevitz Engineering, Pensauker, N.J., Library of Congress 76-24971 (1976); and *Inertial Navigation Systems* by Broxmeyer, McGraw-Hill (1964) describe such calculations and are hereby incorporated herein by reference). The elements 158, 156' and 152' are similar in construction to the elements 158, 156 and 152 described in connection with FIG. 10.

FIG. 14A schematically illustrates further process methodologies according to the invention wherein the six acceleration inputs 207a–207f are processed by the microprocessor subsystem of the invention (e.g., subsystem 12 of FIG. 1) such that centripetal, gravitational, and earth rate compensations are performed so that the various accelerations are properly integrated and compensated to derive speed (and even direction and distance). Specifically, a microprocessor subsystem of the FIG. 14A embodiment includes a centripetal acceleration compensation section 208a which compensates for motions of centripetal accelerations via inputs of surge 207d, heave 207e, and sway 207f. A gravity acceleration compensation section 208b in the subsystem further processes these inputs 207d–207f to compensate for the acceleration of gravity, while a earth rate compensation section 208c thereafter compensates for the accelerations induced by the earth's rotation (e.g., the earth rate acceleration at the equator is approximately opposite in direction to the force of gravity).

Also shown in FIG. 14A are translational integrators 209a–209c which convert the compensated accelerations from inputs 207d–207f to translational velocities by integration. Integrators 210a–210c likewise integrate inputs of pitch 207a, yaw 207b, and roll 207c to angular velocity while integrators 211a–211c provide a further integration to

21

convert the angular velocities to angular position. The angular positional information and translational velocity information is combined and processed at the speed and direction resolution section 212 to derive speed and direction. Preferably, the subsystem with the components 208, 209, 210, 211 and 212 is calibrated prior to use; and such calibration includes a calibration to true North (for a calibration of earth rate).

It should be noted that fewer of the inputs 207a–207f may be used in accord with the invention. For example, certain of the inputs 207a–207f can be removed with the section 208a so that centripetal acceleration is not compensated for. This results in an error in the calculated speed and direction; but this error is probably small so the reduced functionality is worth the space saved by the removed elements. However, with the increased functionality of the several inputs 207a–207f, it is possible to calculate loft height in addition to speed because distance in three axes is known. Therefore, the invention further provides, in one embodiment, information for displaying height achieved during any given “air” time, as described above.

The system of FIG. 14A can additionally measure skier height, off of the ground, through integration of appropriate acceleration vectors indicative of a user’s movement perpendicular to the ground. Snowboarders, skiers and windsurfers (and others) have a desire to know such quantities. A double integration of accelerometers in the direction perpendicular to ground (or thereabouts) during a “loft” time measurement provides the correct signals to determine skier height.

It should be apparent to those in the art that the accelerometers of FIGS. 13–14 provide sufficiently detailed information such that the whole of the system according to the invention can be mounted to a user of the system directly, rather than directly to a vehicle. With the scope of the compensations described in connection with FIG. 14A, for example, movements of the human body, e.g., centripetal motions, may be compensated for to derive speed and/or loft time information that is uncorrupted by the user’s movements. Such compensations, however, require powerful processing power.

Speed Sensor: Pressure Based

Pressure of the air is used in aviation to determine how high an aircraft is. The higher the altitude the lower the air pressure. Pressure sensors according to the invention convert air pressure to an analog voltage. When mounted to a snowboard 220, such as shown in FIGS. 15 and 15A, the pressure sensor 221 is used to determine the altitude of the snowboarder. This voltage is read by the microprocessor subsystem (e.g., the subsystem 12 of FIG. 1) at a fixed rate and differentiated to determine rate of descent or speed in the vertical direction. This may be converted to speed along the path by knowing the grade or angle of descent. Angle of descent is known by predetermining the geometry of the ski path or by the addition of an inclinometer 222 which gives a voltage dependent upon the angle, with respect to vertical, of the platform. The inclinometer 222 measures zero when the ski is traveling along a level path and the pressure sensor is showing a constant pressure. When the ski moves downhill, for example, the inclinometer 222 measures the angle of descent and the pressure sensor measures ever increasing pressure. Since the angle of descent is known, as is the rate of descent, the true speed is determined and displayed.

Those skilled in the art should understand that the elements 221 and 222 are connected in circuit with the further

22

elements of the invention, e.g., the microprocessor subsystem 12 of FIG. 1; and that elements 221 and 222 are shown in FIG. 15 for illustrative purposes only when in fact they exist integrally with the system of the invention, e.g., the system 10 of FIG. 1.

Speed Sensor: Voltage-Resistance Based

Under-water vehicles and many oceanographic instruments measure water velocity by taking advantage of the principle discovered by Faraday that a conductor moving through a magnetic field produces a voltage across the conductor. The voltage produced is greatest when the conductor is orthogonal to the magnetic field and orthogonal to the direction of motion. This principal is used, in accord with the invention, to determine the speed that a skier moves over the snow in winter skiing or over the water in water skiing. As shown in FIGS. 16 and 16A, an electromagnet 241 is mounted to a snowboard 242. Two contacts 240a, 240b are mounted to the snowboard 242 such that the bottom 243a makes contact with the snow and the top 243b of the contacts are connected to a voltage-measuring circuit within the conditioning electronics (such as the electronics 158 of FIG. 10 and such as known to those skilled in the art). When the snowboard 242 is flat on the snow, a conduction path is set up between the two contacts 240a, 240b and through the snow. When the electromagnet 241 is energized, a magnetic field 244 is imposed on the conduction path. As the snowboard 242 moves in the forward direction 245, the conduction path through the snow moves with the snowboard 242. This represents a moving conductor in a magnetic field; and as Faraday’s theorem requires, a voltage 246 across the two terminals 240a, 240b will be generated that is proportional to the snowboarder’s speed. This voltage 246 is read by the microprocessor subsystem (e.g., the subsystem 12 of FIG. 1). When the voltage abruptly goes to zero, and thereafter returns to a high voltage, the microprocessor subsystem determines that the gap in voltage is “air” time. Accordingly, in such an embodiment, no separate sensor 20 is required to measure “air” time (such as described above).

Those skilled in the art will appreciate that the elements of FIGS. 16–16B are shown illustratively for ease of understanding and without the further necessary elements of the invention, e.g., the microprocessor subsystem 12 of FIG. 1.

It should be dear to those skilled in the art that certain modifications can be made to the invention as described without departing from the scope of the invention. For example, vehicles other than skis and mountain bikes may be used with the invention. One vehicle, the snowboard, used in the ever popular snowboarding sport, is particularly well-suited for the invention (e.g., there is no jump skiing). The snowboard also has a wide body and a system constructed according to the invention can be incorporated within the body with the user interface, display, and associated buttons at the snowboard surface, for easy access. FIG. 17 shows such an improvement to a snowboard in accord with the invention. Specifically, a snowboard 270, with boot holder 271, incorporates a system 272 constructed according to the invention. The system 272, like the system 10 of FIG. 1, has a display 274, a user interface 276 that provides a user with buttons to selectively access speed and loft time, as described above, and one or more display portions 278 to display identification information about the displayed times (such as described in connection with FIG. 3).

FIG. 18 shows yet another use of the invention. Specifically, a further application of the invention is found

23

in the sport of ski jumping and ski flying. Ski flying is similar to ski jumping except that ski jumping uses special, extra-long skis, while ski flying uses standard alpine skis. The participant **300** skis down the long ramp **302**, which may be as high as twenty-five stories, and launches horizontally into the air at the end **304** of the ramp **302**. The objective of the sport is for the participant **300** to “jump” or “fly” through the air for as long as possible, and covering the greatest distance as possible. A system constructed according to the invention (not shown) is attached to the ski **310** to measure “air” time, speed, and distance, as described herein. In particular, the speed at the end **304** is used to predict distance by well-known Newtonian physics so that the participant’s overall jump distance is calculated. This removes the necessity of having judges and/or other expensive equipment monitor the event, as the recorded “air” and jump distance is readily displayed by the system of the invention.

Speed Sensor by “Cookie” Measurements

As used herein, “cookie” measurements refer to one technique of the invention for measuring speed. In this method, for example, the sensor drops a measurable entity—e.g., electronic charge—into the snow and then picks it up later at a known distance away to determine the speed. The “charge” in this example is the “cookie.”

In skiing, therefore, this method involves dropping a cookie as the ski travels and then detecting the cookie at a known distance down the length of the ski. The time between placement and detection given a known length between the two occurrences will determine the speed. A cookie therefore represents the placement of some measurable characteristic into the snow underneath. This characteristic may be electrical charge, magnetic moments, a detectable material such as ink, perfume, or a radiation source. The cookies may be dropped at a constant rate, i.e. cookies per second, or at a fixed distance between cookies. In such cases the cookies are said to be dropped in a closed loop fashion. Also the amount of charge, magnetic moment, or detectable material may be controlled so that the detection occurs just above threshold. This will tend to minimize the amount of electrical power used and minimize the amount of material dispensed.

In FIGS. **19** and **19A**, a snowboard **498** traveling in a direction **504** has two sets of electrodes attached to the ski. The first set of electrodes **503** is used to charge a small amount of snow **499** by applying an electric potential across terminals **501a** and **501b**. The potential in that snow **499** is then read by the set of electrodes **502**, accomplished by sampling the potential between terminals **500a** and **500b**.

Since the level of charge in the snow **499** will be quite low, an instrumentation amplifier may be used to condition the signal, such as known to those skilled in the art. FIG. **19B** shows the charge and detection loop according to the preferred embodiment. A potential source—e.g., a battery **499**—is used to charge the first electrodes **503**. When the output of the instrumentation amplifier **501** is above a predetermined threshold, the control and timing circuit **505** triggers a flip-flop (not shown) that notifies the microprocessor that the charge is detected. The time that transpired between placing the charge at **503** to detecting the charge at **502** is used to determine the speed the ski is traveling. The speed is simply the distance between the two sets of electrodes **503** to **502** divided by the time between setting and receiving the charge. The functionality of the timing and control circuit **505** can be separate or, alternatively, can be within the microprocessor such as described herein.

24

The second set of electrodes **502** that is used to detect the charge may also be used to clear the charge such as by driving a reverse voltage (from the control and timing circuit **505** and through direct circuitry to the electrodes **502**). In this manner to total charge resulting from the ski traversing the field of snow will be zero so that there will be no charge pollution. Also it will not confuse another ski speed detection system according to the invention.

The situation described above is also applicable to magnetic moment cookies. In FIG. **20**, for example, a ski **507** shown traveling in a direction **512** has an electromagnet **511** mounted on top of the ski **507** and a magnetic sensor **510**. As the skier skis along the electromagnet is used to impress a magnetic moment into the snow and water that resides under the ski **507**. This is done by asserting a strong magnetic field from the electromagnet **511** and through the ski for a short period of time. This polarization may then be detected by the magnetic sensor **510**. The period of time it takes from creating the magnetic moment at **511** to detecting it at **510** may be used in determining the speed of the ski **507** (such as through control and timing circuitry such as described in connection with FIG. **19B**). The magnetic sensor **510** may also be used to cancel the magnetic moment so that the total magnetic moment will be zero after the ski travels from placement through detection and removal.

One other speed measurement system is shown in FIG. **21**. Specifically, an optical correlation system is shown in FIG. **21** and includes a laser source and receiver contained in package **522**. The laser is directed through two windows **520** and **521**. The laser backscatter is cross correlated over time between the two windows **520**, **521**. This means that the two time signals are multiplied and integrated over all time with a fixed time delay between the two signals. The time delay between the two backscatter signals that yields the highest cross correlation is the period of time the ski took to travel the distance of the two windows. The speed of the ski may then be determined knowing the window separation. The source that is used does not have to be a laser but can be noncoherent visible light, infrared or any high frequency electromagnetic radiation.

The invention thus provides a series of unique sensing technologies which are appropriate for sporting activities such as skiing, snowboarding, windsurfing, skate-boarding, mountain biking, and roller-blading. Specifically, the invention is used to “sense,” quantify and communicate to the user selected motions for various sporting activities. These motions include (A)–(C) below:

(A) Air Time

One embodiment of the invention—appropriately called the “airmeter” measures “air” time, i.e., the time for which a person such as a skier is off the ground, such as during a jump. The airmeter is battery-powered and includes a microprocessor and a low-powered liquid crystal display (LCD) to communicate the “air” time to the user. There are many ways the airmeter can “detect” the loft times associated with measuring “air” time; and certain techniques are better than others for various different sports. By way of example, certain of these airtime devices utilize accelerometers and/or microphone technology as part of the microprocessor circuit. All of the components for this device are cheap and plentiful; and are conveniently packaged within a single integrated circuit such as an ASIC.

The airmeter provides several features, including:

- total and peak air time for the day
- total dead time for the day
- air time for any particular jump

25

successive jump records of air time averages and totals, selectable by the user rankings of records logic to reject activities which represents false "air" time toggle to other device functionality user interface to control parameters

(2) Speed

Certain of the sporting activities described above also benefit by the measurement of vehicle speed. Again, in the detection of this motion, one embodiment of the invention utilizes relatively simple and inexpensive technologies to sense, quantify and display vehicle speed. This device can be stand-alone, or it is incorporated within several of the other devices discussed herein. For example, one combination device will provide both "air" time and speed to the user of the device.

One method of determining speed utilizes the Doppler effect of microwave energy wherein energy transmits right through the vehicle, e.g., a ski or snowboard, and reflects off the moving ground to generate a Doppler signal. The absence of this signal is also used by PhatRat—in certain embodiments—to sense air time.

The speed measuring device of the invention provides several features, including:

- total average speed for the day
- peak speeds
- successive speed records
- averages and totals, selectable by the user
- rankings of records
- logic to reject activities which contaminate speed measurements
- toggle to other device functionality
- user interface to control parameters

(3) "Power"

One embodiment of the invention also measures user "power," i.e., the amount of energy absorbed or experienced by a user during the day. By way of example, this "power" meter is useful for a kayaker in that it would assess and quantify the power or forces experienced by a white-water ride. One output of the power meter of the invention is the number of "g's" absorbed by the user.

Again, in the detection of power, the power meter utilizes relatively simple and inexpensive technologies to sense, quantify and display "g's" and/or other measures of how "hard" a user played in a particular activity. As above, this device can be stand-alone, or it is incorporated within several of the other devices discussed herein. For example, one combination device will provide "air" time, power and speed to the user of the device.

The power meter measuring device provides several features, including:

- average absorbed power
- peak power for the activity
- successive power records
- averages and totals, selectable by the user
- rankings of records
- logic to reject activities which contaminate power measurements
- toggle to other device functionality
- user interface to control parameters
- units control such as to display "g's" and/or other measures

As shown in FIG. 22, a pair of power meters 600 is also used to quantify competitions such as mogul competitions.

26

One power meter 600A mounts to the ski 602, and another power meter 600B mounts or attaches to the user's upper body 604; and an RF signal generator 606 communicates (via antenna 606a) the power information to a controller at a base facility 608 (e.g., a judges center for judging the mogul skiers). Those skilled in the art should appreciate that one or both power meters 600 can communicate the information to the base, as shown; however, one power meter can also communicate to the other power meter so that one communicates to the base. However, in either case, an RF transmitter and receiver is needed at each meter. Alternatively, other inter-power meter communication paths are needed, e.g., wiring, laser or IR data paths, and other techniques known to those in the art.

The combined signals from the meters 600 assess the force differential between the lower legs 604a and the upper body 604, giving an actual assessment of a competitor's performance. A computer at the base station 608 can easily divide one signal by the other to get a ratio of the two meters 600 during the run. The meters 600 start transmitting data at the starting gate 610 and continue to give data to the base 608 during the whole run on the slope 612. The meters can also be coupled to the user via a microphone 614 (and wire 616) to provide a hum or pitch which tells that user how effective his/her approach is. Although it is not shown, one or both meters have the microprocessor within so as to enable the features described in connection with the power meters. For example, the microprocessor can be used to provide a power measurement in "Gs" for the competitor once she reaches the base 608.

Other features can also be determined in accord with the invention such as through measurements with the system of FIG. 14A. For example, once you know your starting velocity, you can measure distance traveled and height above the ground by knowing the air time for a given jump.

Other ways of doing this are by using accelerometers to integrate the height distance. The preferred way of determining distance is to know your velocity at the jump start location, such as described herein, and to use the air time to establish a distance traveled, since distance is equal to velocity times time (or air time).

For height, you can also determine the height traveled by looking at the time to reach the ground. That is, once in the air, you are accelerating towards the ground at 9.81 meters per second². So, you first determine the time for which there is no more upwards movement (such as by using an accelerometer that knows gravity direction and which changes directions at the peak, or by using circuitry which establishes this movement), and then calculate the distance traveled (in height) by knowing that the height is equal to $\frac{1}{2} a t^2$, where a is the acceleration of gravity (9.81 m/s²) and t is the air time after the peak height is reached. If the person does not travel UP at any time during the jump, then the height is simply $\frac{1}{2} a t^2$ where t is the complete air time.

An accelerometer-based vibration and shock measurement system 620 is shown in FIG. 23. This system 620 measures and processes accelerations associated with various impact sports and records the movement so that the user can determine how much shock and vibration was endured for the duration of the event. The duration is determined with a simple start stop button 622, although duration can alternatively start with an automatic recording that is based on the measured acceleration floor.

The vibrations and shock associated with skiing or exercise are measured by the use of an accelerometer 624 (or other motion device, e.g., a microphone or piezoelectric device) and conditioning electronics 626 as shown in FIG.

23. The accelerometer 624 typically is AC-coupled so that low frequency accelerations, or the acceleration due to gravity, may be ignored. The accelerometer output is then conditioned by passing the signal through a band pass filter within the electronics 626 to filter out the low frequency outputs, such as the varying alignment to the gravity vector, as well as the high frequency outputs due to electrical noise at a frequency outside the performance of the accelerometer 624. The resulting signal is one that has no DC component and that is bipolar such as the waveform shown in FIG. 24.

The system 620 thus conditions the signal and remove the negative components of the waveform in FIG. 24. This is done, for example, by rectifying the output of the bandpass signal. Since a positive acceleration is likely to be accompanied by a negative of the same area, the area of the positive may be doubled to obtain the area of the positive and negative. The signal may also be processed by an absolute value circuit. This can be done via an Operational Amplifier circuit such as the one shown in the *National Semiconductor Linear Applications Data Book Application Note AN-31.*, which is herein incorporated by reference. In accord with certain processes, known to those skilled in the art, positive values become positive; and negative values become positive. By way of example, the waveform of FIG. 24 is processed, for example, to the waveform of FIG. 25.

A unipolar waveform like the one shown in FIG. 25 is then integrated over time by the system 620 so that the total acceleration is accumulated. This can also be averaged to determine average shock. The signal of FIG. 25 is therefore processed through an integrator (within the electronics 626 or the microprocessor 628) which will result in the signal shown in FIG. 26. A value of "power" can then be displayed to a user via the display 630.

The period of integration may be a day or simply a single run down a slope; or it may be manually started and stopped at the beginning and end of a workout. The output is then be fed into a logarithmic amplifier so that the dynamic range may be compressed. The logarithmic amplifier can be accomplished within the microprocessor 628.

At any stage, the system 620 can be fed into an analog-to-digital converter (such as within the electronics 626) where the signal processing is done digitally. The output of the accelerometer 624 should anyway pass through an antialiasing filter before being read by a microprocessor 628. This filter is a low pass filter that will ensure that the highest frequency component in the waveform is less than half the sampling rate as determined by the Nyquist criteria.

The accelerometer 624 output can also be processed through an RMS circuit. The Root Mean Square acceleration is then determined from the following formula:

$$A_{\text{RMS}} = \frac{1}{T} \left[\int_0^T A^2(t) dt \right]^{\frac{1}{2}}$$

where T is the period of the measurement and A (t) is the instantaneous accelerometer output at any time t. The period T may be varied by the user and the output is a staircase where each staircase is of width T. This is then peak-detected and the highest RMS acceleration stored; and an average acceleration and a histogram are stored showing a distribution of RMS accelerations. These histograms are displayed on a Liquid Crystal graphical display 630, for example, as a bargraph.

An alternate embodiment is to record the signal in time and transform the signal to the frequency domain by performing a Fourier transformation to the data (such as within

the electronics 626 or the microprocessor 628). The result would be distribution of the accelerations as a function of frequency which is then integrated to determine the total signal energy contained. The distribution is, again, plotted on the LCD display 630.

Data may also be acquired by the accelerometer and telemetered to the electronics 626 via an RF link 631 back to a remote location 632 for storage and processing. This enables ski centers to rent the accelerometer system 620 so as to be placed on the ski to record a day of runs and to give a printout at the end of the day.

A separate memory module or data storage device 634 can also be used to store a selected amount of time data which can be uploaded at the end of the day. The data can be uploaded itself via a Infrared link readily available off the shelf, as well as through a wire interface or through an RF link 631.

The system 620 is particularly useful in impact sports that include mountain biking, football, hockey, jogging and any aerobic activity. Low impact aerobics have become an important tool in the quest for physical fitness while reducing damage to the joints, feet and skeletal frames of the exerciser. The system 620 may also be used by a jogger to evaluate different running shoes. Alternatively, when calibrated, the system 620 is useful to joggers who can gate it to serve as a pedometer. The addition of a capacitor sensor in the heel electronics helps determine average weight. A sensor for skin resistivity may additionally be used to record pulse. The shoe can record the state of aerobic health for the jogger which is of significant interest to a person involved in regular exercise. The system 620 can also be used to indicate the gracefulness of a dancer while they develop a particular dance routine. A football coach may place these systems 620 in the helmets of the players to record vibration and shock and use it as an indicator of effort.

In skiing, the system 620 has other uses since a skier glides down a mountain slope and encounters various obstructions to a smooth flight. Obstructions such as moguls cause the skier to bump and induce a shock. This shock can be measured by the accelerometer 624 and accumulated in a memory 634 to keep a record of how much shock was encountered on a particular ski run. Exercisers may use such a system 620 to grade their ability to avoid impact. A jogger may use the system 620 to evaluate their gate and determine their running efficiency. This becomes important with a greater emphasis being placed on low impact aerobics.

Those skilled in the art should appreciate that other improvements are possible and envisioned; and fall within the scope of the invention. For example, an accelerometer-based system 620 mounted on a ski may be used to determine the total shock and vibration encountered by a skier traveling down a slope. Mounting an additional accelerometer 624 above the skier's hip allows a measurement of the isolation the skier provides between upper torso and ski. This can be used to determine how well a trained skier has become in navigating moguls. This measurement of the isolation is made by taking an average of the absolute value of the accelerations from both accelerometers 624. The ratio of the two accelerations is used as a figure of merit or the isolation index (i.e., the ratio between two measurements such as on the ski and the torso, indicating how well the mogul skier is skiing and isolating knee movement from torso movement).

To avoid the complications of gravity affecting the measurements of system 620, a high pass filter should be placed on the accelerometer output or within the digital processor sampling of the output. All analog signals should have

29

antialiasing filters on their outputs whose bandwidth is half the sampling frequency. Data from the accelerometers 624 can sampled continuously while the circuits are enabled. The processor 628 may determine that a ski run has started by a rise in the acceleration noise floor above a preset trigger for a long enough duration. In another embodiment, a table is generated within the processor of each sufficiently high acceleration recorded from the ski. The corresponding upper torso measurement may also be recorded along with the ratio of the two measurements. The user can additionally display the n-bumpiest measurements taken from the skis and display the isolation index.

FIG. 28 shows a ski 700 mounted with a GPS sensor 702 that is coupled to a microprocessor subsystem 704 such as described herein. The GPS sensor 702 tells absolute position in terms of height and earth location. By monitoring the signal from the GPS sensor 702, speed, height and loft time can be determined. That is, at each signal measurement, a difference is calculated to determine movement of the ski 700; and that difference can be integrated to determine absolute height off of the ground, distance traveled, speed (i.e., the distance traveled per sample period), and loft time.

FIG. 29 shows a strain gauge 720 connected to a microprocessor subsystem 722 such as described above. The gauge 720 senses when there is little or now stress on the ski 724, such as when the ski 724 is in the "air"; and the subsystem 722 thus determines loft time from that relatively quiescent period.

Alternatively, the element 720 can be a temperature gauge that senses the change in temperature when the ski 724 leaves the ground. This change of temperature is monitored for duration until it again returns to "in contact" temperature. The duration is then equated to "loft time" or some calibrated equivalent (due to thermal impedence). Note that the impedence of air will be different from snow; and hence that change can be measured by the gauge 720 in this embodiment.

FIG. 30 shows one speed, loft and power meter 740, constructed according to the teachings herein and mounted to the ski 741, that additionally has an RF transmitter 742 to communicate signals from the meter 740 to a watch 744 worn by the user (not shown). In this manner, the user can easily look at the watch 744 (nearly during some sporting activities) to monitor the measured characteristics in near-real time. A small watch display 744a and internal memory 744b provide both display and storage for future review.

The devices for measuring speed, loft time and power as described herein can oftentimes be placed within another component such as a user's watch or a ski pole. For example, the power meter system 620 of FIG. 23 can easily be placed within a watch such as watch 744, and without the sensor 740, since power integration can be done from almost anywhere connected to the user. Likewise, loft time measurement through the absence of a spectrum, such as shown in FIG. 4, can also be done in a watch or a ski pole. Speed measurements, however, are much more difficult if not impossible to do at these locations because of the lack of certainty of the direction of movement. However, with the increased performance and size reductions of guidance systems with accelerometers (see FIGS. 14 and 14A), even this can be done.

It is accordingly intended that all matter contained in the above description or shown in the accompanying drawings be interpreted as illustrative rather than in a limiting sense.

It is also intended that the following claims cover all of the generic and specific features of the invention as described herein, and all statements of the scope of the

30

invention which, as a matter of language, might be said to fall there between.

Having described the invention, what is claimed as new and secured by Letters Patent is:

1. A system for measuring a power absorbed by a user on a moving vehicle over a surface and over a predetermined time interval, the system comprising:

a sensor for detecting vibration of the moving vehicle and for generating signals indicative of the vibration, the vibration being substantially perpendicular to the surface;

a microprocessor for processing the signals to determine the absorbed power over the predetermined time interval, the predetermined time interval being greater than about 500 milliseconds and less than about eight hours; and

means for informing the user of the absorbed power.

2. A system according to claim 1, further comprising means for determining average absorbed power.

3. A system according to claim 2, further comprising means for storing the average absorbed power and for informing the user of the average absorbed power.

4. A system according to claim 1, further comprising means for determining peak power for user activity.

5. A system according to claim 4, further comprising means for storing peak power information and for informing the user of the peak power information.

6. A system according to claim 1, further comprising means for storing successive power records and for informing the user of the records, selectively, upon user command.

7. A system according to claim 1, further comprising means for averaging power data and for informing the user of average power data.

8. A system according to claim 1, further comprising means for ranking power records and for informing the user of the ranking.

9. A system according to claim 1, further comprising logic for rejecting user activities which contaminate power measurements.

10. A system according to claim 1, further comprising means for determining g-forces imposed on the user through the moving vehicle.

11. A system according to claim 1, further comprising a loft sensor for determining air time of the moving vehicle off of the surface.

12. A system according to claim 1, further comprising a speed sensor for determining the speed of the moving vehicle.

13. A system according to claim 1, further comprising a height sensor for determining a height of the user above the ground during a jump.

14. A system according to claim 13, further comprising means for determining a peak height of the user above the ground.

15. A system according to any one of claims 11, 12 or 13, further comprising toggle means for facilitating user control of power measurement and other sensor functionality.

16. A system according to claim 1, further comprising an RF transmitter for communicating data to and from the system.

17. A system according to claim 1, further comprising a user interface.

18. A system according to claim 1, further comprising a display for displaying power data to the user.

19. A system according to claim 1, further comprising one or more user interface buttons to enable user control of the system.

31

- 20. A system according to claim 1, further comprising AC-coupling means for rejecting unwanted signals.
- 21. A system according to claim 1, further comprising rectification means for rectifying power signals.
- 22. A system according to claim 1, further comprising an integrator for integrating power signals in connection with determining power.
- 23. A system according to claim 22, further comprising means for integrating power data over a day.
- 24. A system according to claim 22, further comprising means for integrating power data over a run down a slope.
- 25. A system according to claim 22, further comprising manual start and stop means for integrating power data between start and stop.
- 26. A system according to claim 22, further comprising means for integrating power data over a workout period.
- 27. A system according to claim 1, further comprising a logarithmic amplifier for compressing data dynamic range.
- 28. A system according to claim 1, further comprising analog to digital converter means for converting analog power data to digital data, for processing by the microprocessor.
- 29. A system according to claim 1, wherein the sensor comprises an accelerometer.
- 30. A system according to claim 1, further comprising an RMS circuit to provide RMS power data to the user.
- 31. A system according to claim 30, wherein the RMS circuit comprises means for determining RMS acceleration.
- 32. A system according to claim 1, further comprising histogram means for displaying histogram power data to the user.
- 33. A system according to claim 32, further comprising bar graph means for presenting histogram data as a bar graph to the user.
- 34. A system according to claim 1, further comprising means for recording motion signals, for transforming the signals to a frequency domain through a Fourier transformation, and for integrating the transformed signals to provide a total signal energy to the user.

32

- 35. A system according to claim 1, further comprising a remote base station, means for connecting the remote base station datawise with the microprocessor via RF communications, and means for storing power data wherein the user can receive a print-out of power data.
- 36. A system according to claim 1, further comprising memory for storing selected power data for subsequent retrieval by the user.
- 37. A system according to claim 36, further comprising an infrared data link to communicate data stored in the memory to the user.
- 38. A system according to claim 1, further comprising means for determining average weight of the user.
- 39. A system according to claim 1, further comprising anti-aliasing means to suppress undesirable signals from the determination of power.
- 40. A system according to claim 1, further comprising means for determining signal strength above a certain noise floor.
- 41. A system according to claim 40, further comprising means for determining the occurrence of signal strength over the noise floor for a selected duration.
- 42. A system for measuring power of a moving vehicle operated by a user over a surface and over a predetermined time interval, the system comprising:
 - a sensor for detecting a vibration of the moving vehicle and for generating a first set of signals indicative of the vibration, the vibration being generated substantially perpendicular to the surface;
 - signal conditioning electronics for transforming the first set of signals into a second set of signals
 - a microprocessor for processing the second set of signals to determine the absorbed power over the predetermined time interval, the predetermined time interval being greater than about 500 milliseconds and less than about eight hours; and
 - means for informing the user of the absorbed power.

* * * * *



US006018705A

United States Patent [19]
Gaudet et al.

[11] **Patent Number:** **6,018,705**
[45] **Date of Patent:** **Jan. 25, 2000**

- [54] **MEASURING FOOT CONTACT TIME AND FOOT LOFT TIME OF A PERSON IN LOCOMOTION**
- [75] Inventors: **Paul J. Gaudet**, Tewksbury; **Thomas P. Blackadar**, Natick; **Steven R. Oliver**, Attleboro, all of Mass.
- [73] Assignee: **Personal Electronic Devices, Inc.**, Wellesley Hills, Mass.
- [21] Appl. No.: **08/942,802**
- [22] Filed: **Oct. 2, 1997**
- [51] **Int. Cl.⁷** **G01C 22/00; G04F 10/00**
- [52] **U.S. Cl.** **702/176; 702/141; 702/160; 702/142; 368/10; 235/105**
- [58] **Field of Search** **702/160, 176, 702/144, 141, 142, 149; 368/10; 235/105**

5,323,650	6/1994	Fullen et al.	73/172
5,343,445	8/1994	Cherdak	368/10
5,357,696	10/1994	Gray et al.	36/136
5,361,778	11/1994	Seitz	128/779
5,422,628	6/1995	Rodgers	340/573
5,437,289	8/1995	Liverance et al.	128/779
5,452,269	9/1995	Cherdak	368/10
5,485,402	1/1996	Smith et al.	364/566
5,526,290	6/1996	Kanzaki	364/565
5,541,860	7/1996	Takei et al.	364/566
5,583,776	12/1996	Levi et al.	364/450
5,623,944	4/1997	Nashner	128/779
5,636,146	6/1997	Flentovet al.	364/569
5,720,200	2/1998	Anderson et al.	73/172
5,724,265	3/1998	Hutchings	364/565

Primary Examiner—Marc S. Hoff
Assistant Examiner—Hien Vo
Attorney, Agent, or Firm—Wolf, Greenfield & Sacks, P.C.

- [56] **References Cited**
- U.S. PATENT DOCUMENTS**
- 3,972,038 7/1976 Fletcher et al. 340/189
- 3,974,491 8/1976 Sipe
- 4,408,183 10/1983 Wills
- 4,409,992 10/1983 Sidorenko et al. 128/782
- 4,499,394 2/1985 Koal
- 4,578,769 3/1986 Frederick
- 4,649,552 3/1987 Yukawa
- 4,651,446 3/1987 Yukawa et al. 36/132
- 4,745,564 5/1988 Tenmes et al. 364/566
- 4,763,287 8/1988 Gerhaeuser et al. 364/561
- 4,771,394 9/1988 Cavanagh
- 4,774,679 9/1988 Carlin
- 4,814,661 3/1989 Ratzlaff et al. 310/328
- 4,830,021 5/1989 Thornton
- 4,855,942 8/1989 Bianco
- 4,956,628 9/1990 Furlong
- 5,033,013 7/1991 Kato et al. 364/561
- 5,186,062 2/1993 Roost
- 5,269,081 12/1993 Gray
- 5,285,586 2/1994 Goldston et al. 36/137

[57] **ABSTRACT**

The time period that a foot is in contact with the ground during a stride taken by a user, and the period that the foot is not in contact with the ground between strides taken by the user are determined by processing and analyzing the output signal of an accelerometer. The accelerometer is mounted on the user such that its acceleration sensing axis senses acceleration in a direction substantially parallel to the bottom of the user's foot. The output of the accelerometer is high-pass filtered, amplified, and fed to the input of a micro-controller, which monitors the signal for positive and negative signal spikes that are indicative, respectively, of the moment that the foot of the user leaves the ground and the moment that the foot impacts with the ground. By measuring time intervals between these positive and negative spikes, average "foot contact times" and "foot loft times" of the user may be calculated. To derive the pace of the user, the average foot contact time is multiplied by a first constant if it is less than 400 milli-seconds (ms) and is multiplied by a second constant if it is greater than 400 ms. This pace value may, in turn, be used to calculate the distance traveled by the user.

38 Claims, 13 Drawing Sheets

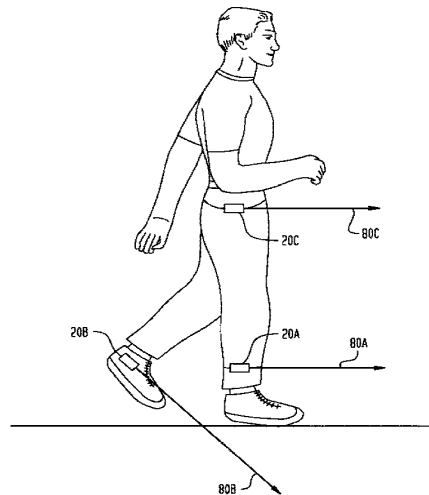

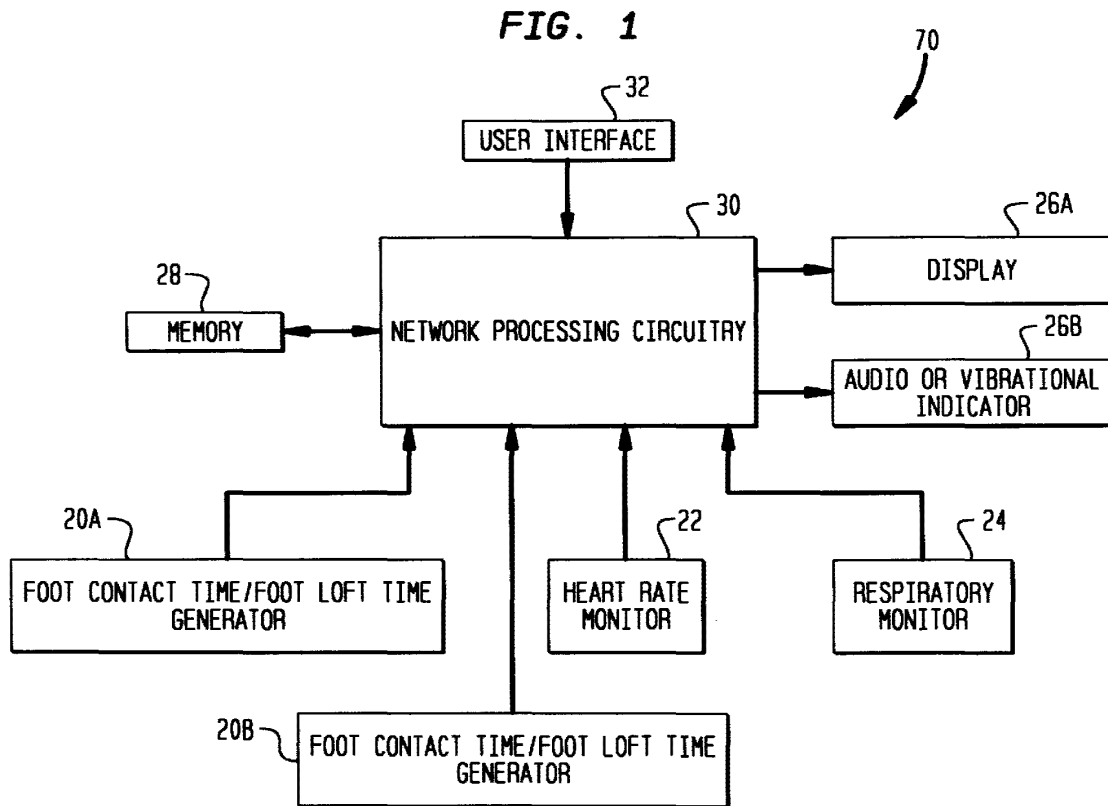

FIG. 2

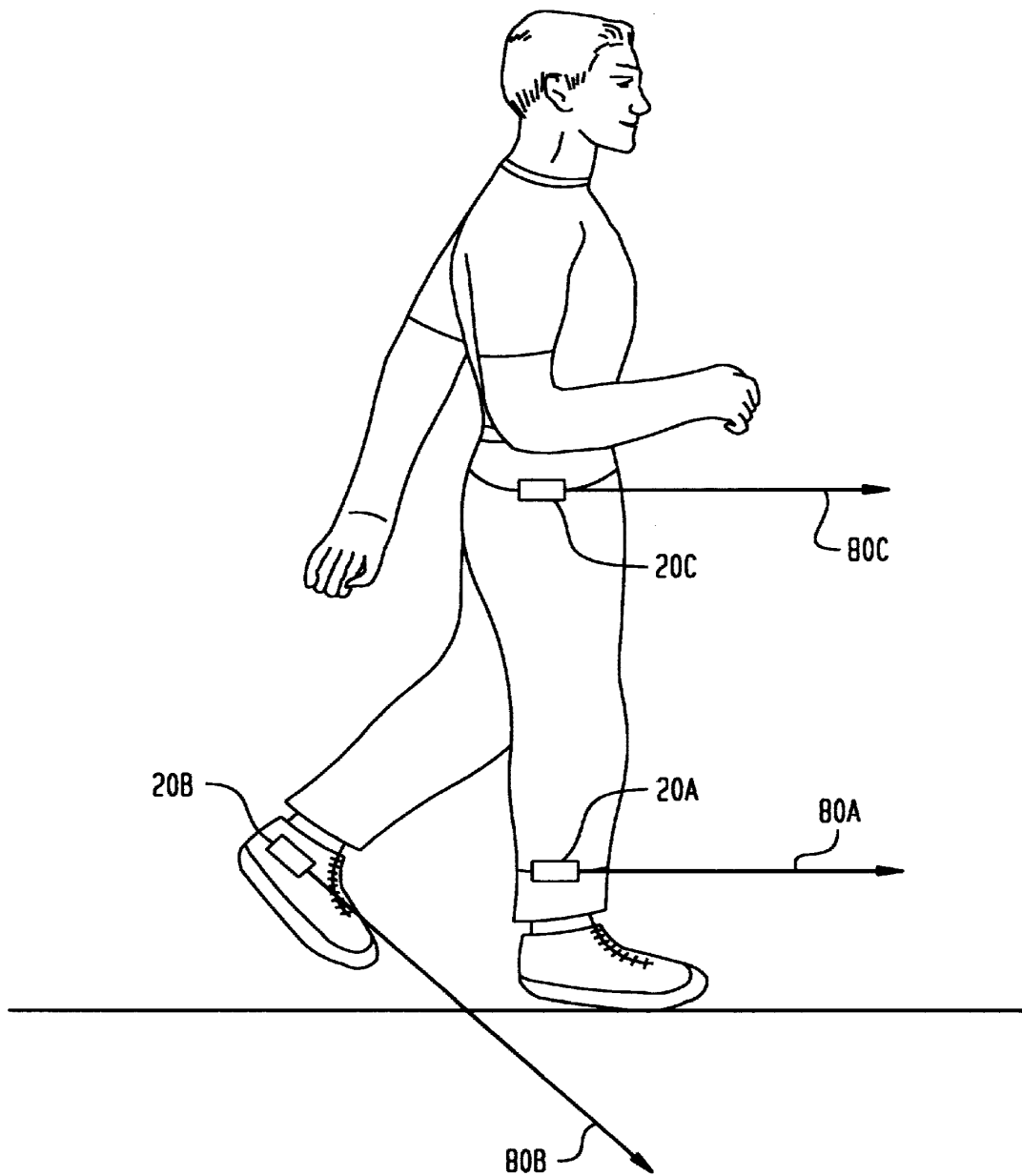

FIG. 3

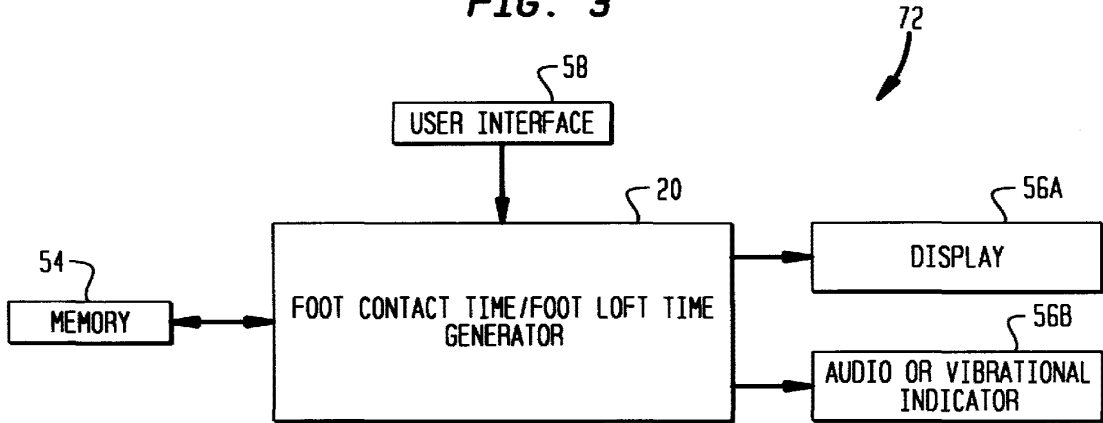

FIG. 4

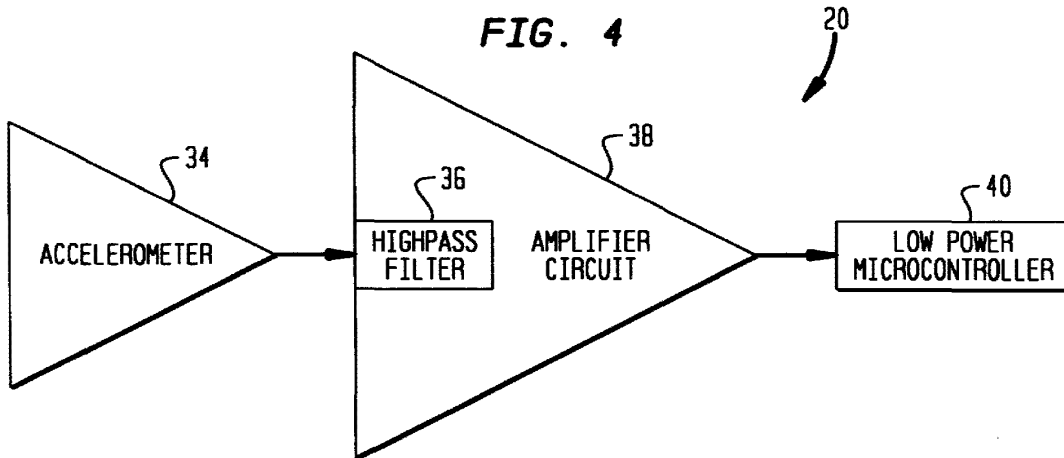

FIG. 5

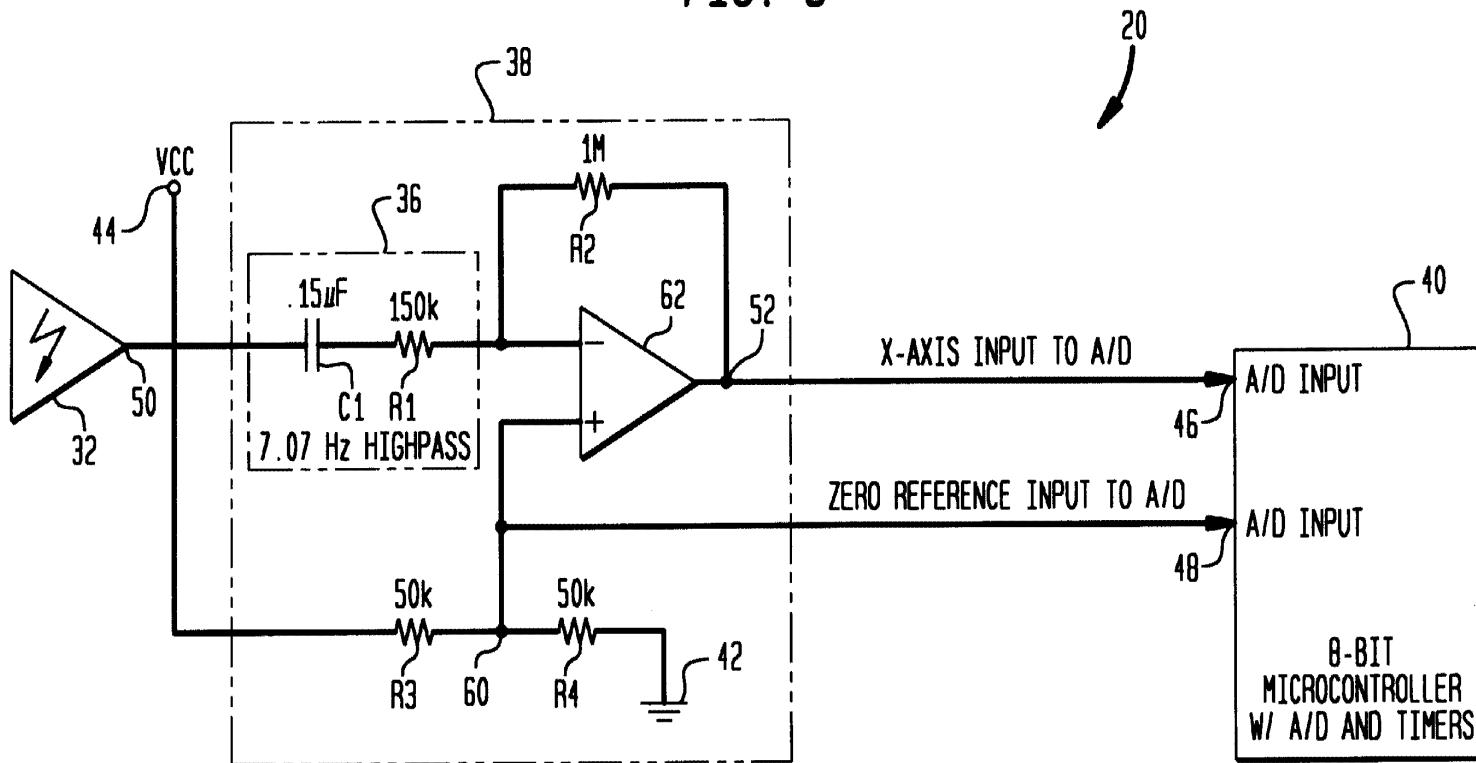

FIG. 6

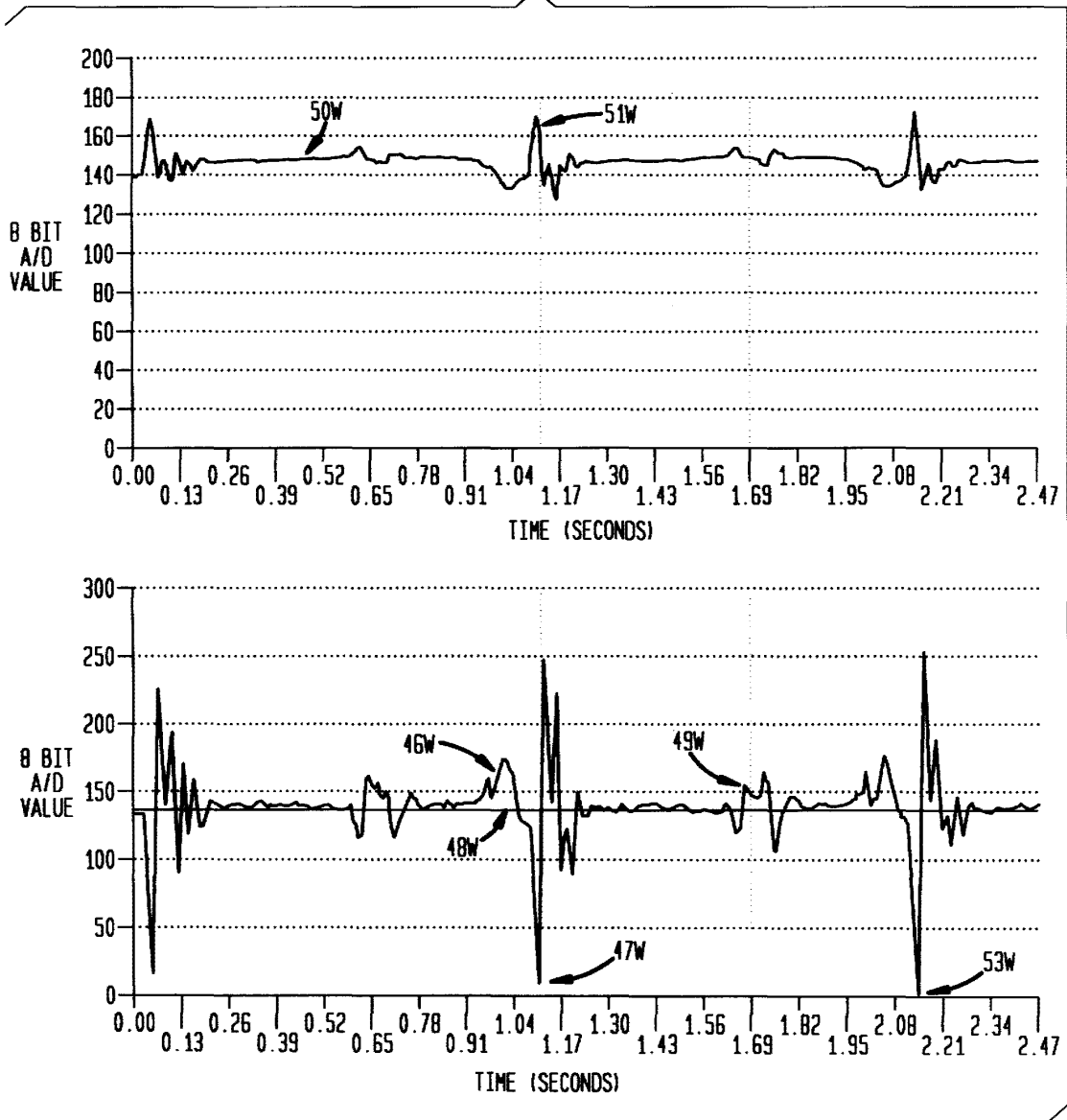

FIG. 7

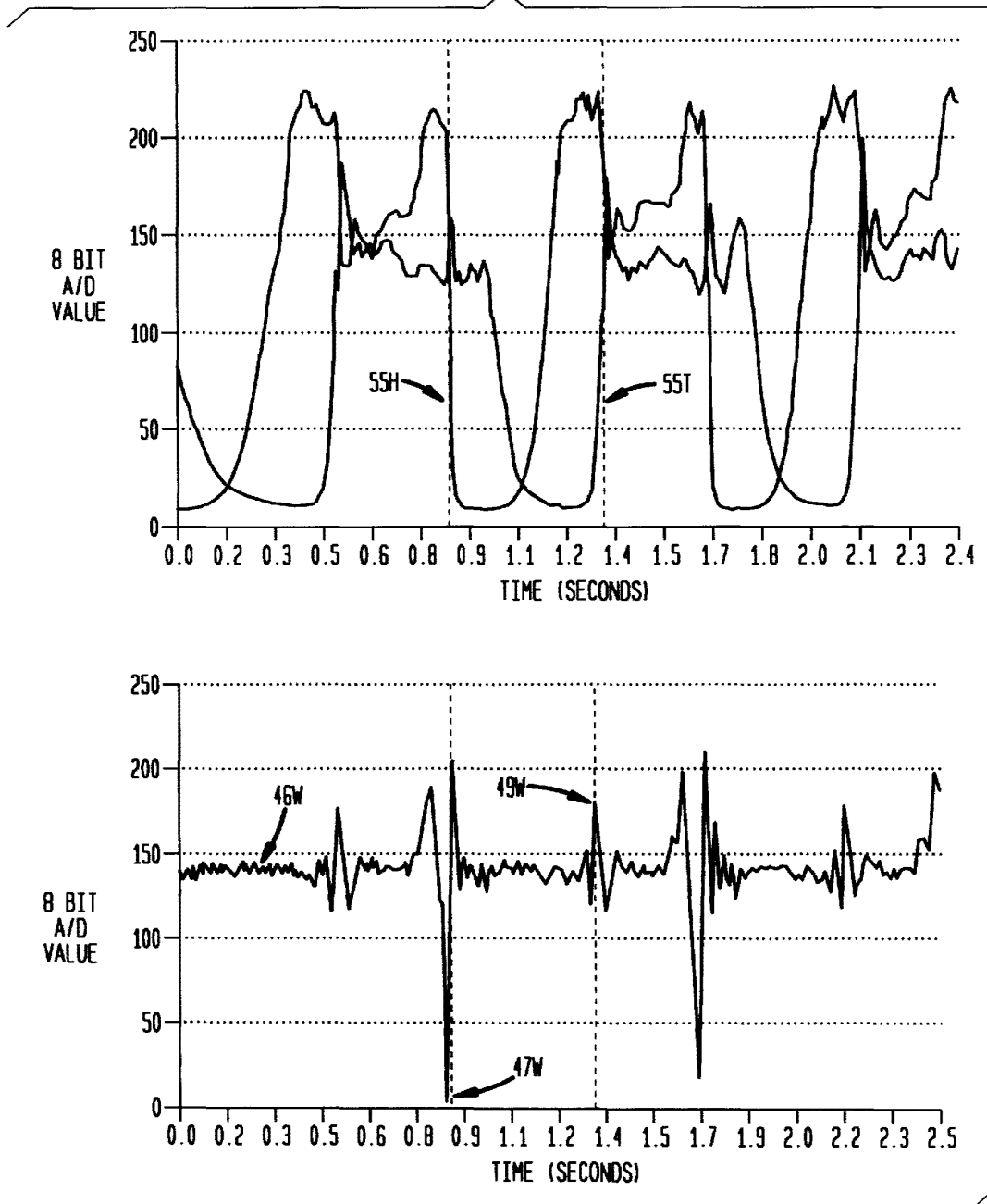

FIG. 8

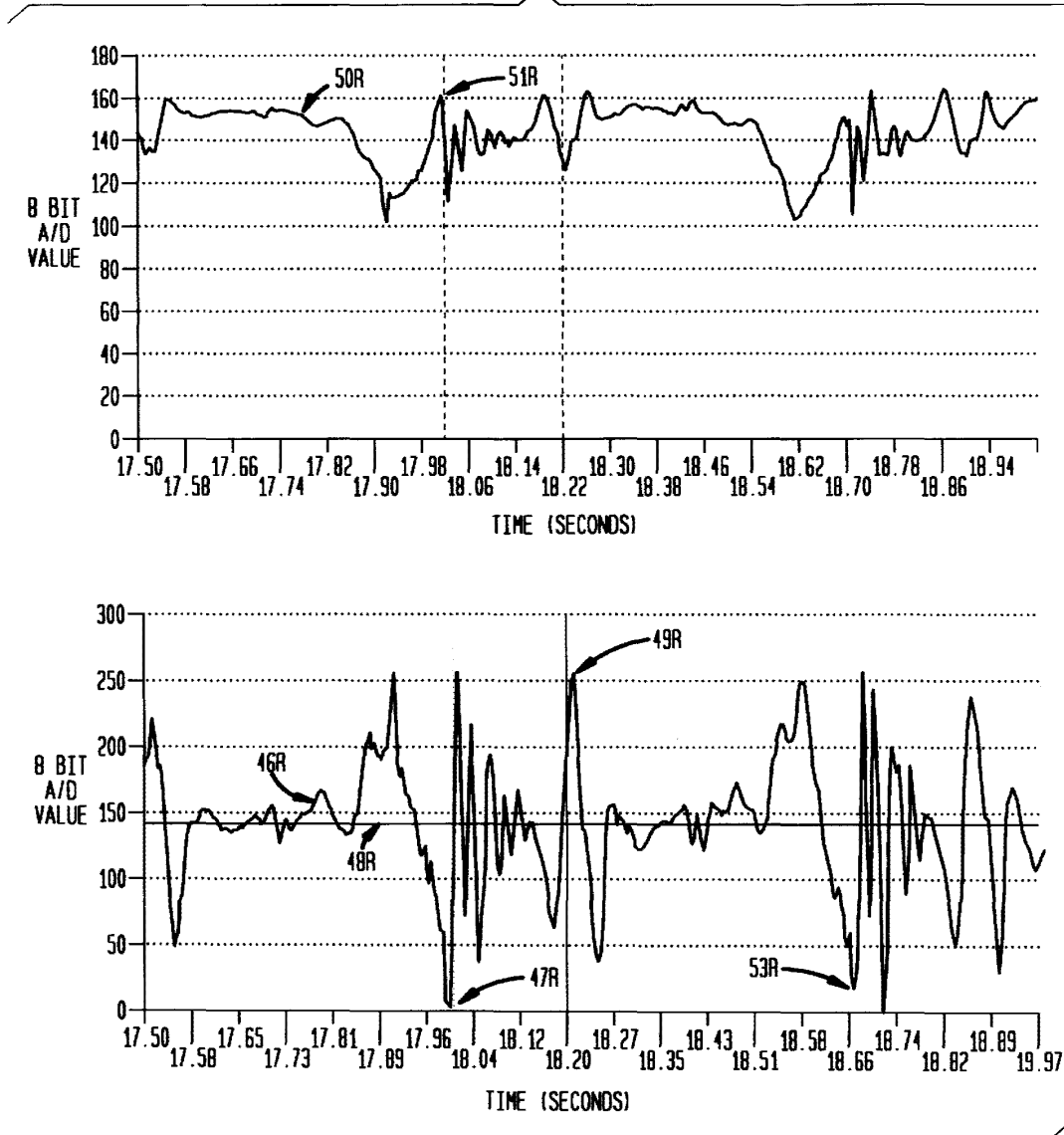

FIG. 9

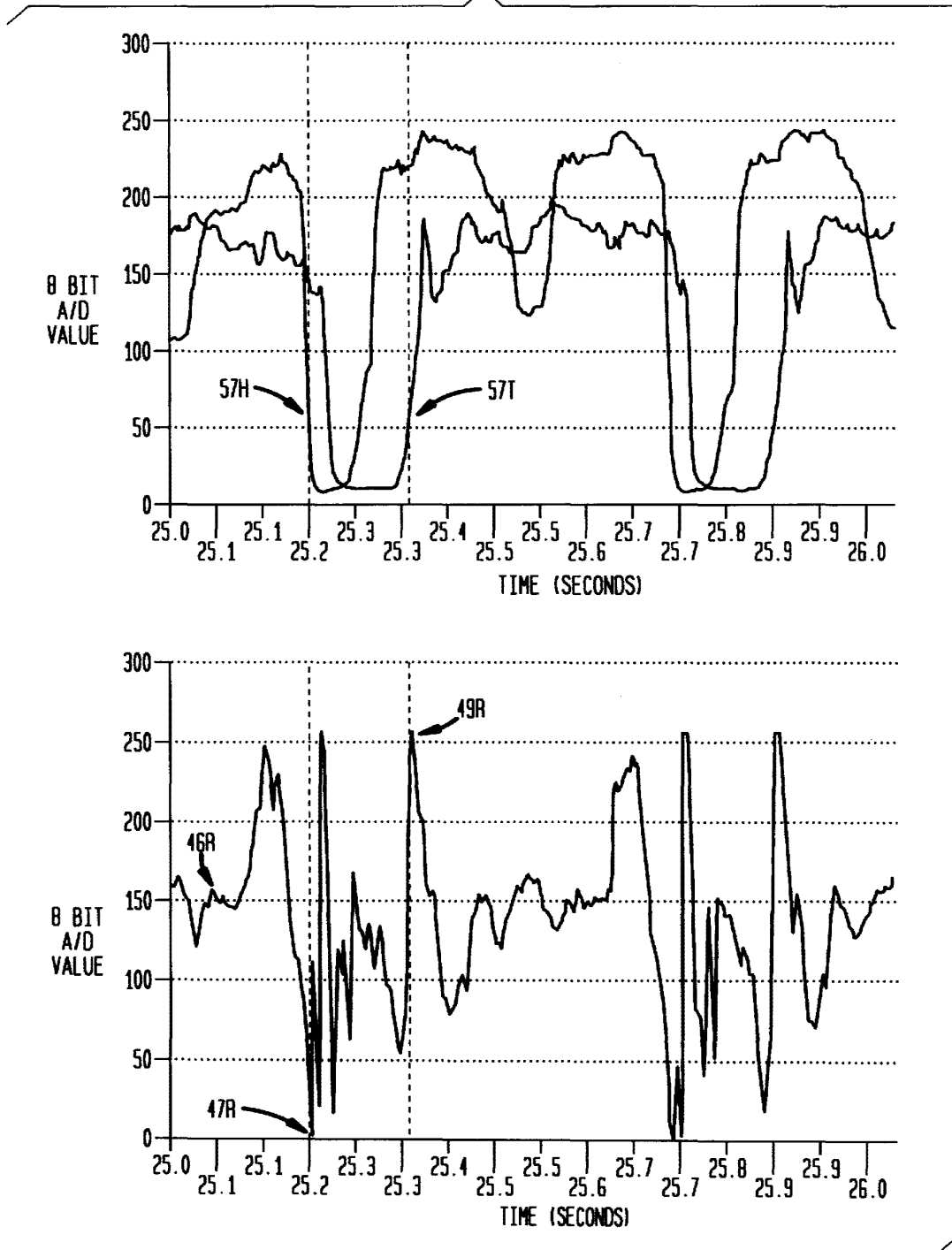

FIG. 10

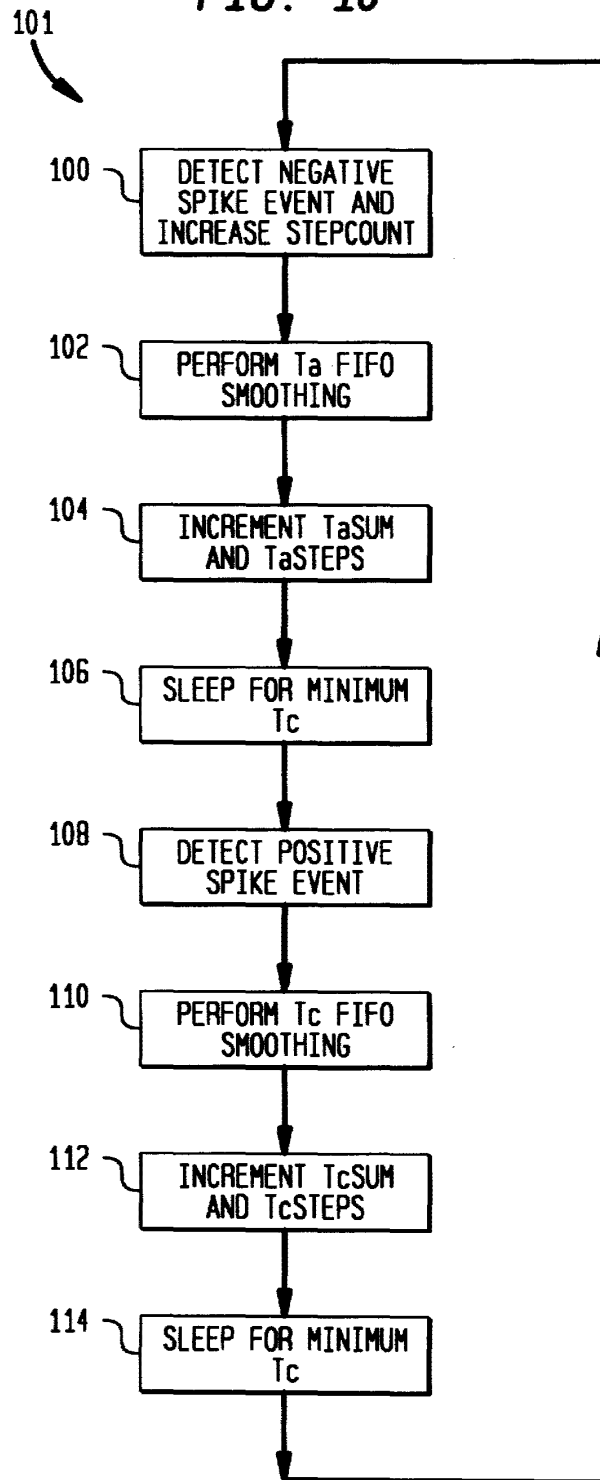

FIG. 11

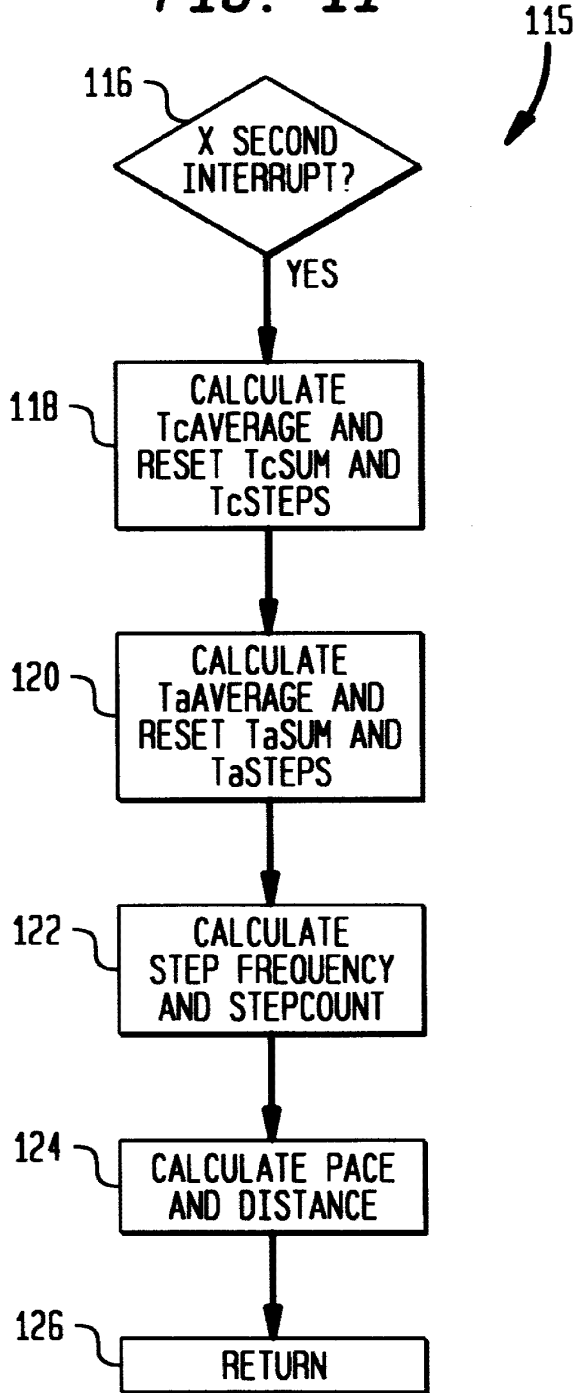

FIG. 12

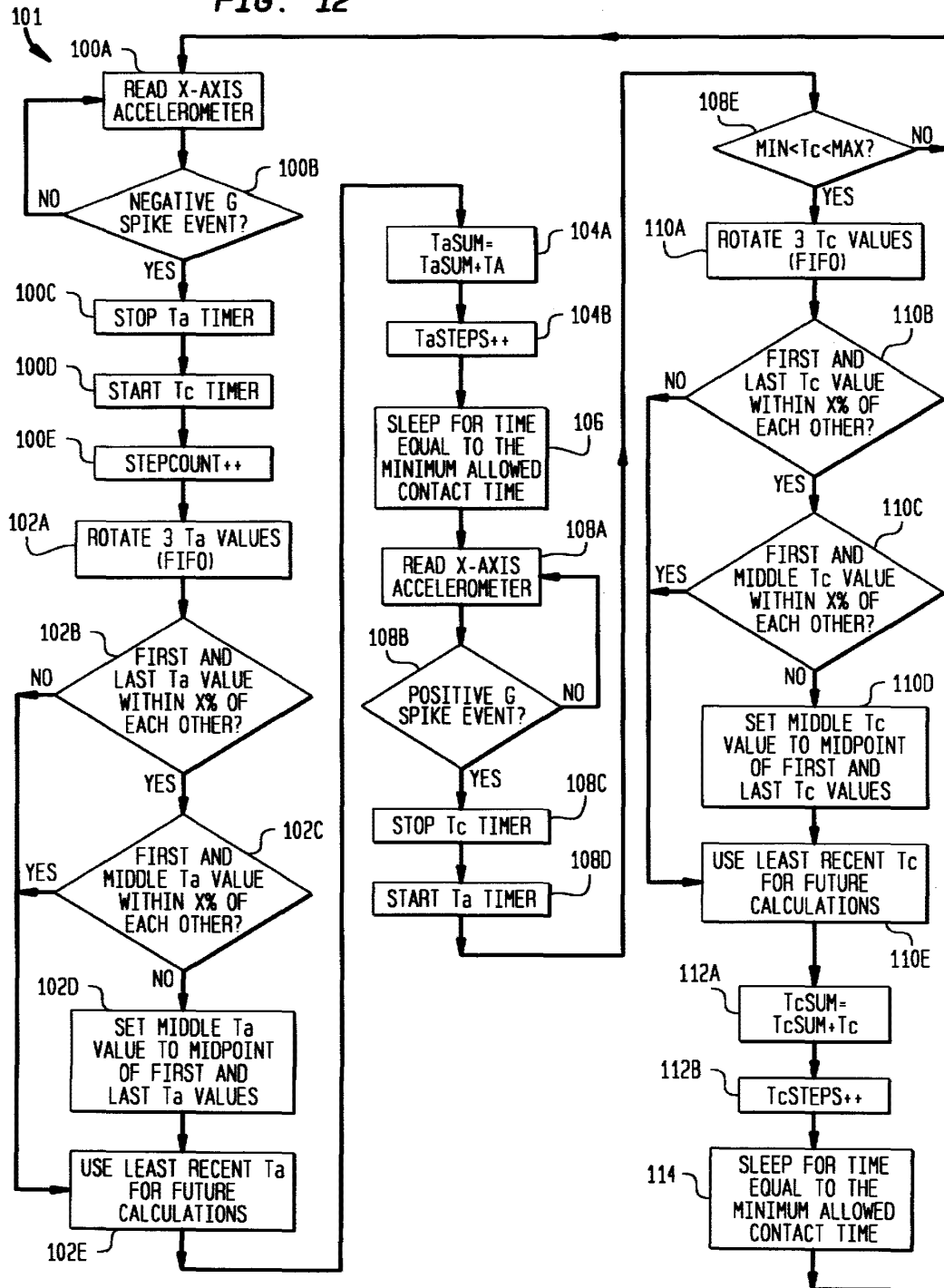

FIG. 13

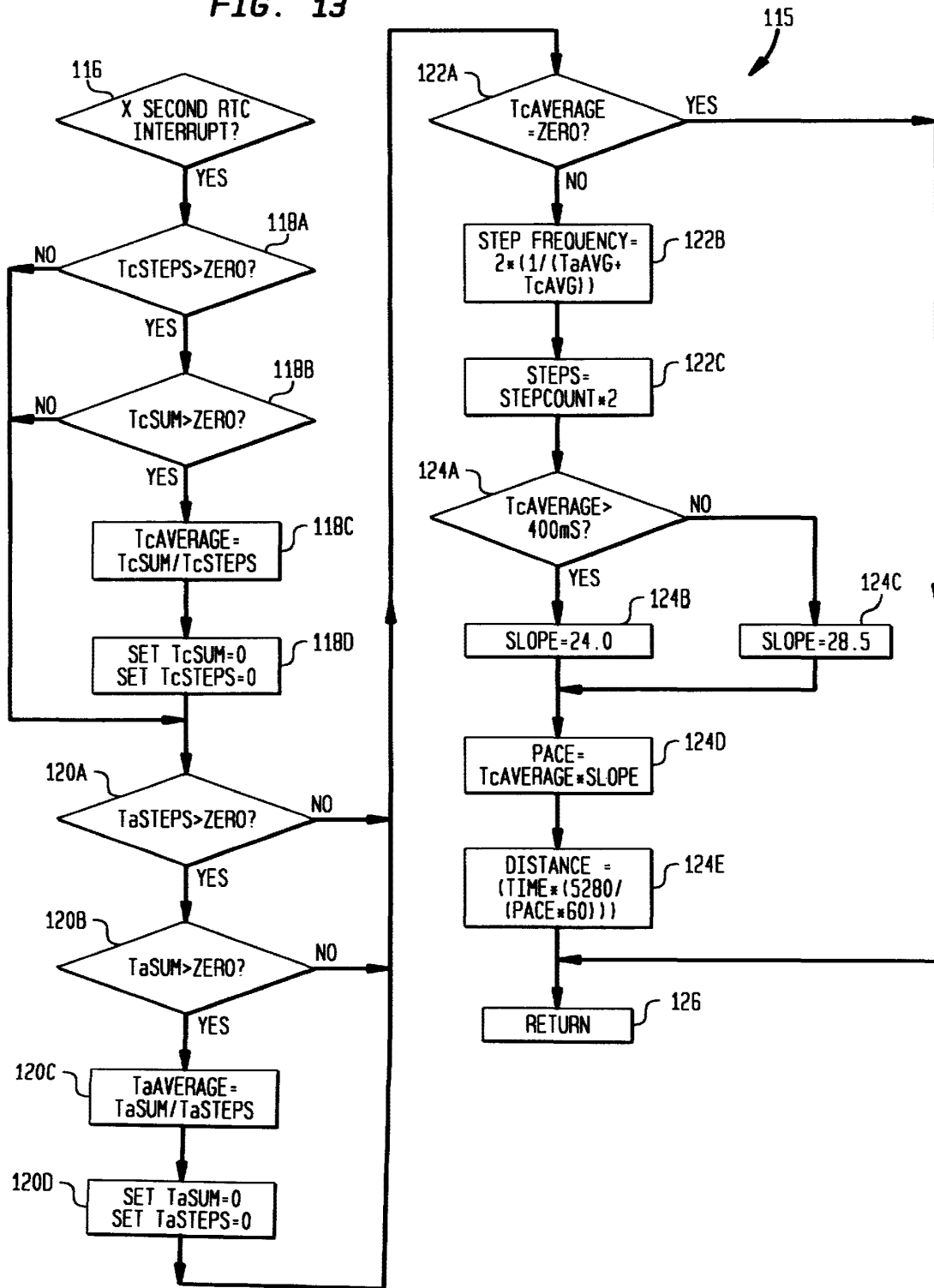
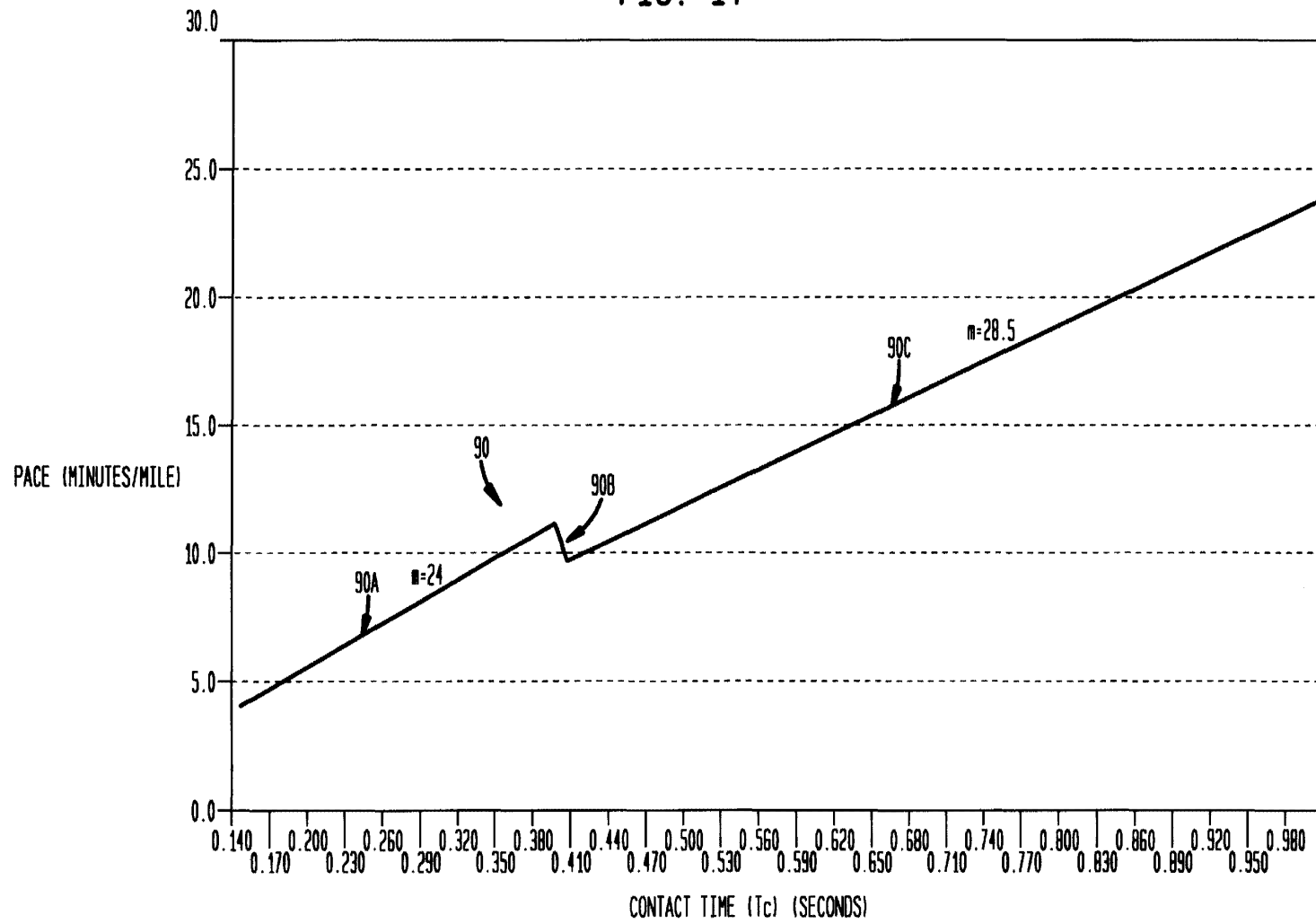

FIG. 14



1

MEASURING FOOT CONTACT TIME AND FOOT LOFT TIME OF A PERSON IN LOCOMOTION

BACKGROUND OF THE INVENTION

1. Field of the Invention

The present invention relates to the monitoring of the orthopedic motion of a person and, more particularly, to the measuring of foot contact time, foot loft time, speed and/or pace of a person in locomotion.

2. Discussion of the Related Art

It is known that useful information may be derived from the measurement of the "foot contact time" of a person in locomotion, wherein "foot contact time" refers to the period of time that a foot of a person is in contact with the ground during a stride taken by the person. Once the foot contact time of a person is known, other information, such as rate of travel, distance traveled and ambulatory expended energy may be calculated based upon this measured foot contact time.

In the past, foot contact time has been measured by placing pressure-sensitive sensors or switches, such as resistive sensors, in both the heel and toe portions of the sole of a shoe, and measuring a time difference between a first signal output by the heel sensor (which indicates that the foot has made physical contact with the ground) and a second signal output by the toe sensor (which indicates that the foot has left the ground). These sensors, however, are subjected to a high-impact environment inside of the shoe, and therefore fail frequently. In addition, inaccurate foot contact time measurements may result when a user is taking strides during which either the heel sensor or the toe sensor is not activated, for example, when a user is running on his or her toes.

Another device well-known in the art is a pedometer. A pedometer typically is mounted on the waist of a user and is configured to count the footsteps of the user by measuring the number of times the user's body moves up and down during footsteps taken by the user. A well-known prior art pedometer design uses a weight mounted on a spring to count the number of times that the user's body moves up and down as the user is walking. By properly calibrating the pedometer according to a previously measured stride length of the user, the distance traveled by the user may be measured by this device. These "weight-on-a-spring" pedometers, however, generally cannot measure the distance traveled by a runner because the weight experiences excessive bouncing during running and footsteps are often "double-counted" because of this bouncing, causing the pedometer to produce inaccurate results. These devices, therefore, may not be used across different training regimes (e.g., walking, jogging, and running).

Another prior art pedometer device uses an accelerometer to measure the number of times that a foot impacts the ground when a user is in locomotion. That is, an accelerometer is mounted on a shoe so as to produce a signal having pronounced downward going peaks that are indicative of moments that the foot impacts the ground. These devices therefore produce results similar to the prior art weight-on-a-spring pedometer devices in that they merely count the number of footsteps of a user, and must be calibrated according to the stride length of the user in order to calculate the distance traveled by the user. Thus, these accelerometer-based devices are subject to similar limitations as are the weight-on-a-spring devices, and are not able to measure the foot contact time of a user in locomotion.

2

It is therefore a general object of the present invention to provide a new approach to pedometry that is affordable, reliable, easy to use and accurate.

SUMMARY OF THE INVENTION

According to the invention, a method and an apparatus are disclosed in which an output of an accelerometer is used to determine: (1) instances at which a foot of a user in locomotion leaves a surface, and (2) instances at which the foot of the user impacts the surface. By measuring the time difference between each instance at which the foot impacts the surface and the following instance at which the foot leaves the surface, several periods of time that the foot was in contact with the surface during strides taken by the user, i.e., several foot contact times, may be measured accurately and reliably. By calculating an average of these several measured foot contact times, an average foot contact time may be determined, from which information such as the pace of the user, rate of travel, distance traveled, etc., may be calculated. Additionally, by measuring time differences between the instances at which the foot of the user leaves the surface and the following instances at which the foot impacts the surface, the average period of time that the foot was not in contact with the surface, i.e., the average foot loft time, between strides taken by the user also may be calculated.

According to one aspect of the present invention, a method for analyzing the motion of a foot relative to a surface includes using an output of an accelerometer to determine a moment that the foot leaves the surface.

According to another aspect of the invention, the output signal of the accelerometer, which is indicative of the acceleration of the foot, is fed to a signal processing circuit configured to analyze the signal to determine a moment that the foot leaves the surface.

According to another aspect, the output of the accelerometer also is used to determine a moment that the foot comes into contact with the surface.

According to yet another aspect, a foot contact time may be determined based upon a difference between the moment that the foot comes into contact with the surface and the moment that the foot leaves the surface, or a foot loft time may be determined based upon a time difference between the moment that the foot leaves the surface and the moment that the foot comes into contact with the surface.

According to yet another aspect of the invention, the measured foot contact time is used to determine the rate at which a user is moving relative to the surface. Further, by measuring the time interval that the user is in locomotion, the distance that the user has traveled may be determined by multiplying the rate at which the user is moving by the time interval during which the rate measurement was determined.

According to another aspect, a method for determining a rate that a user is moving on foot relative to a surface includes the steps of: (a) determining a foot contact time of a user in locomotion; (b) if the foot contact time is less than a first amount of time, then deriving the rate at which the user is moving according to a first equation in which the foot contact time is a factor; and (c) if the foot contact time is greater than a second amount of time, which is greater than the first amount of time, then deriving the rate at which the user is moving according to a second equation in which the foot contact time is a factor.

According to another aspect of the invention, a device for analyzing the motion of a foot relative to a surface includes an accelerometer and a signal processing circuit. The accel-

3

erometer is supported in relation to the foot and is configured and arranged to provide an output signal indicative of the acceleration of the foot. The signal processing circuit is coupled to the accelerometer to receive the output signal from it, and is configured to analyze the output signal to determine at least one moment that the foot leaves the surface.

According to another aspect of the invention, the processing circuit also is configured to analyze the output signal to determine at least one moment that the foot makes contact with the surface. Additionally, according to yet another aspect, the processing circuit is configured to: (1) analyze the output signal to determine at least one time period that the foot was in contact with the surface during at least one stride taken by the foot; and/or (2) analyze the output signal to determine at least one time period that the foot was not in contact with the surface between strides taken by the foot.

According to another aspect, a device for determining the rate at which a user in locomotion is moving includes processing circuitry adapted to receive information regarding a foot contact time. The processing circuitry is configured such that if the foot contact time is less than a first amount of time, then the processing circuitry derives the rate at which the user is moving according to a first equation in which the foot contact time is a factor, and if the foot contact time is greater than a second amount of time, which is greater than or equal to the first amount of time, then the processing circuitry derives the rate at which the user is moving according to a second equation in which the foot contact time is a factor.

BRIEF DESCRIPTION OF THE DRAWINGS

FIG. 1 is a block diagram of a network in which the present invention may be used;

FIG. 2 is an illustration showing how the invention may be mounted with respect to a user;

FIG. 3 is a block diagram of a system in which the invention may be used;

FIG. 4 is a block diagram of one embodiment of a circuit according to the present invention;

FIG. 5 is a schematic diagram of the circuit shown in FIG. 4;

FIG. 6 is a pair of graphs showing signals at two nodes of the circuit shown in FIG. 5 during a period in which a user is walking;

FIG. 7 is a pair of graphs that compare the amplified/filtered output of the accelerometer according to the invention with data obtained using prior art resistive sensors during a period that a user is walking;

FIG. 8 is a pair of graphs showing signals at two nodes of the circuit shown in FIG. 5 during a period in which a user is running;

FIG. 9 is a pair of graphs that compare the amplified/filtered output of the accelerometer according to the invention with data obtained using prior art resistive sensors during a period that a user is running;

FIG. 10 is a high-level flow diagram of a continuous-loop portion of a method for measuring foot contact time according to the invention;

FIG. 11 is a high-level flow diagram of an interrupt portion of the method for measuring foot contact time according to the invention;

FIG. 12 is a more detailed flow diagram of the continuous-loop portion of the method shown in FIG. 10;

4

FIG. 13 is a more detailed flow diagram of the interrupt portion of the method shown in FIG. 11; and

FIG. 14 is a graph illustrating how the pace of a user in locomotion may be determined based upon the average measured foot contact time of a foot of the user.

DETAILED DESCRIPTION OF THE INVENTION

FIG. 1 shows a block diagram of a network 70 in which the present invention may be used. As shown, network 70 includes network processing circuitry 30, a memory unit 28, a user interface 32, a display 26A, and an audio or vibrational indicator 26B. Network processing circuitry 30 also is coupled to receive inputs from one or more monitoring devices, such as foot contact time/foot loft time generators 20A and 20B, heart rate monitor 22, and respiratory monitor 24. The devices shown in FIG. 1 may be linked together, for example, via direct wiring or capacitive coupling, by using radio-frequency (RF) or infra-red (IR) transmitters/receivers, or by any other information transmission medium known to those skilled in the art.

Network processing circuitry 30 may include a personal computer, or any other device capable of processing information from the various inputs of network 70. Memory unit 28 is coupled to network processing circuitry 30 and is used to store programming and data for network processing circuitry 30 and/or to log data processed by circuitry 30. User interface 32 also is coupled to network processing circuitry 30 and permits a user, e.g., a walker, jogger or runner, to select a particular feature implemented by operation of a software routine, to input particular operating parameters, or to select particular outputs for display 26A and/or audio or vibrational indicator 26B. Heart rate monitor 22 and respiratory monitor 24 operate according to known methods and supply inputs to network processing circuitry 30.

Each one of foot contact time/foot loft time generators 20A and 20B operates according to the present invention and supplies a separate input to network processing circuitry 30. By receiving information from the outputs of foot contact time/foot loft time generators 20A and 20B, heart rate monitor 22, and respiratory monitor 24, as well as inputs from any other type of electronic health monitoring device, network processing circuitry 30 is able to process all such information and provide a user with a fitness metric, to help the user attain a peak fitness level in the most efficient manner possible, or other health related information, useful for physical therapy, recovery, etc.

FIG. 2 illustrates how a device according to the invention may be mounted on a user. Each of devices 20A-20C shown in FIG. 2 has a particular axis in which it senses acceleration, i.e., an acceleration sensing axis. According to one embodiment of the invention, each of the devices should be mounted such that the acceleration sensing axis of the device is oriented substantially parallel to a bottom surface of the foot of the user. For example, device 20A is mounted on the ankle of the user, device 20B is mounted on or within the shoe of the user, and device 20C is mounted on the waist of the user, with the acceleration sensing axes of the devices being oriented as indicated by arrows 80A, 80B and 80C, respectively. In each case, this positioning of the acceleration sensing axis has been found to produce an output signal that is most strongly indicative of both: (1) the moment at which the foot of the user leaves the surface, and (2) the moment at which the foot of the user comes into contact with the surface. It is hypothesized that this is true because a large

5

portion of the change in acceleration sensed by the device is caused by the friction between the shoe of the user and the surface, rather than being caused primarily by the impact of the shoe with the surface, as is the case with prior art accelerometer-based pedometers.

FIG. 3 shows a system 72 according to the present invention. As shown, the system 72 includes a foot contact time/foot loft time generator 20 (which could correspond to either of foot contact time/foot loft time generators 20A and 20B in FIG. 1), a memory unit 54, a user interface 58, a display 56A, and an audio or vibrational indicator 56B. According to one embodiment, foot contact time/foot loft time generator 20 includes a micro-controller having virtually all circuitry, e.g., memory, timers and analog-to-digital (A/D) converters, on board, so that memory unit 54 need only be used to perform functions such as permanently storing data produced by foot contact time/foot loft time generator 20.

User interface 58 may be activated conventionally by means of buttons, switches or other physically actuated devices, or may be voice activated using a commercially available voice activation device. As discussed in more detail below, user interface 58 may be used, for example: (1) to adjust any of several parameters used in a software routine according to the invention, (2) to select any of several possible outputs for the user, e.g., outputs could be displayed on display 56A or could provide a user with an audio or vibrational indication via audio or vibrational indicator 56B, or (3) to select features which are implemented through software routines called automatically responsive to user inputs.

FIG. 4 shows an exemplary embodiment of the foot contact time/foot loft time generator 20 shown in FIG. 3. As shown, foot contact time/foot loft time generator 20 includes an accelerometer 34, an amplifier circuit 38 (which has a high-pass filter 36 included within it), and a micro-controller 40. An output of accelerometer 34 is connected to an input of amplifier circuit 38, and an output of amplifier circuit 38 is connected to an input of micro-controller 40.

FIG. 5 shows the foot contact time/foot loft time generator 20 shown in FIG. 4 in more detail. As shown in FIG. 5, output 50 of accelerometer 32 is provided to an input capacitor C1 included in amplifier circuit 38. Amplifier circuit 38 further includes operational amplifier 62 and resistors R1-R4. According to one embodiment, accelerometer 32 may comprise part number ADXL250, manufactured by Analog Devices, Inc., and operational amplifier 62 may comprise part number MAX418 produced by MAXIM, Inc.

As shown in FIG. 5, resistor R1 is connected between input capacitor C1 and the inverting input of operational amplifier 62, and resistor R2 is connected in feedback between the inverting input terminal and output 52 of operational amplifier 62. Thus, the combination of input capacitor C1 and resistor R1 form a high-pass filter, and the position of resistors R1 and R2 place the amplifier circuit in an inverting configuration with a gain-factor dependent on the relative values of resistors R1 and R2. In the embodiment shown, resistor R1 has a value of one mega-ohm and resistor R2 has a value of 150 kili-ohms, so that the gain factor of the amplifier is approximately (-6.6). In addition, according to the embodiment shown, capacitor C1 has a value of 0.15 microfarads, so that high-pass filter section 36 of amplifier circuit 38 cuts off input signal frequencies that are less than approximately 7.07 hertz.

Resistor R3 is connected between VCC supply node 44 and the non-inverting input 60 of operational amplifier 62,

6

and resistor R4 is hconnected between non-inverting input 60 and ground node 42. VCC supply node 44 is maintained at approximately 5 volts (e.g., regulated from a six-volt battery) in relation to ground node 42, and resistors R3 and R4 are of equal values (e.g., 50 kili-ohms each) so that the voltage at non-inverting input node 60 is maintained approximately midway between the voltage at VCC supply node 44 and ground (i.e., approximately 2.5 volts).

Output 52 of amplifier circuit 38 is connected to a first A/D input 46 of low-power micro-controller 40, and node 60 of amplifier circuit 38 is connected to a second A/D input 48 of micro-controller 40. According to one embodiment, micro-controller 40 may comprise part number PIC16C73 manufactured by Microchip, Inc. This micro-controller includes on-board memory, A/D converters, and timers. A/D input 48 of micro-controller 40 serves as a zero-reference that is maintained at approximately 2.5 volts (as described above), and input 46 of micro-controller 40 serves as a variable input that fluctuates between 0 and 5 volts. Micro-controller 40 samples the voltages at inputs 46 and 48 at a rate of approximately 500 samples-per-second, converts these samples into 8-bit unsigned digital values, and calculates the difference between the voltages at the two inputs, which difference is used during operation of software routines described in more detail below.

FIG. 6 shows two curves along the same time axis. These curves represent the 8-bit unsigned digital values of the voltages at nodes 50 and 52 of the circuit shown in FIG. 5 during a period when a user is walking. That is, curve 50W in FIG. 6 represents (digitally) the voltage at output 50 of accelerometer 32 before it is filtered and amplified, and curves 46W and 48W, respectively, represent (digitally) the voltages at inputs 46 and 48 of micro-controller 40 during the period when the user is walking. While each of curves 46W, 48W and 50W shares a common time axis, the voltage-magnitude axis of curves 46W and 48W is distinct from the voltage-magnitude axis of curve 50W. Therefore, the placement of curve 50W above curves 46W and 48W is not intended to signify that curve 50W attains a higher amplitude than do curves 46W and 48W.

As shown in FIG. 6, because amplifier circuit 38 is configured to have a negative gainfactor, high peak 51W of curve 50W corresponds with low peak 47W of curve 46W. High peak 49W of curve 46W, however, does not appear to correspond to a low peak of curve 50W. That is, high peak 49W is ascertainable only after the output of accelerometer 34 has been high-pass filtered and amplified by amplifier circuit 38. It is high peak 49W in curve 46W that indicates the moment that the foot of the user has left the surface when the user is in locomotion.

Similarly, low peak 47W in curve 46W indicates the moment that the foot of the user has impacted with the surface when the user is in locomotion. By measuring the time difference between peak 47W and peak 49W of curve 46W, the foot contact time of the user when the user is in locomotion may be ascertained. As used herein, "foot contact time" refers to the period of time between when a foot of a user impacts a surface and when the foot next leaves the surface.

In a similar manner, the foot loft time of a user in locomotion may be determined. That is, by measuring the time difference between high peak 49W and low peak 53W in curve 46W, the foot loft time of the user is ascertainable. As used herein, "foot loft time" refers to the period of time between when a foot of a user leaves a surface and when the foot next comes into contact with the surface.

FIG. 7 shows the correspondence, when a user is walking, between (1) two curves 55H and 55T produced by resistive sensors mounted in the heel and toe, respectively, of a shoe and (2) the amplified and filtered output of the accelerometer according to the invention. That is, curve 55H represents the output of a resistive sensor mounted in the heel of a shoe, curve 55T represents the output of a resistive sensor mounted in the toe of the shoe, and curve 46W represents the voltage at node 52 of circuit 20 (shown in FIG. 5). All of these measurements were taken while a user was walking. While each of curves 55H, 55T and 46W shares a common time axis, the voltage-magnitude axis of curves 55H and 55T is distinct from the voltage-magnitude axis of curve 46W. Therefore, the placement of curves 55H and 55T above curve 46W is not intended to signify that curves 55H and 55T attain higher amplitudes than does curve 46W.

As shown by the dashed lines in FIG. 7, the high to low transition of curve 55H (which indicates that the shoe of the user has impacted with the ground) corresponds with low peak 47W of curve 46W, and the low-to-high transition of curve 55T (which indicates that the shoe of the user has left the ground) corresponds with high peak 49W of curve 46W. Thus, the foot contact time and foot loft time measurements that are obtained, when a user is walking, by measuring time differences between high and low peaks, and vice-versa, of the high-pass filtered/amplified output of an accelerometer (mounted as described above) appear to produce results that are at least as accurate as those produced by prior art resistive sensors.

FIG. 8 shows two curves representing the 8-bit unsigned digital values of the voltages at nodes 50 and 52 of the circuit shown in FIG. 5 during a period when a user is running. That is, curve 50R in FIG. 8 represents the voltage at output 50 of accelerometer 32 before it is filtered and amplified, and curves 46R and 48R, respectively, represent the voltages at inputs 46 and 48 of micro-controller 40 during the period when the user is running. While each of curves 46R, 48R and 50R shares a common time axis, the voltage-magnitude axis of curves 46R and 48R is distinct from the voltage-magnitude axis of curve 50R. Therefore, the placement of curve 50R above curves 46R and 48R is not intended to signify that curve 50R attains a higher amplitude than do curves 46R and 48R.

As shown in FIG. 8, because amplifier circuit 38 is configured to have a negative gain-factor, high peak 51R of curve 50R corresponds with low peak 47R of curve 46R. High peak 49R of curve 46R, however, does not appear to correspond to a low peak of curve 50R. That is, high peak 49R is ascertainable only after the output of accelerometer 34 has been high-pass filtered and amplified by amplifier circuit 38. It is high peak 49R in curve 46R that indicates the moment that the foot of the user has left the ground when the user running.

Similarly, low peak 47R in curve 46R indicates the moment that the foot of the user has impacted with the ground when the user is running. By measuring the time difference between low peak 47R and high peak 49R of curve 46R, the foot contact time of the user, when the user is running, may be ascertained. In a similar manner, the foot loft time of the user may be determined. That is, by measuring the time difference between high peak 49R and low peak 53R in curve 46R, the foot loft time of the user, when the user is running, may be ascertained.

FIG. 9 shows the correspondence, when a user is running, between (1) two curves 57H and 57T produced by resistive sensors mounted in the heel and toe, respectively, of a shoe

and (2) the amplified and filtered output of the accelerometer according to the invention. That is, curve 57H represents the output of a resistive sensor mounted in the heel of a shoe, curve 57T represents the output of a resistive sensor mounted in the toe of the shoe, and curve 46R represents the voltage at node 52 of circuit 20 (shown in FIG. 5). All of these measurements were taken while a user was running. While each of curves 57H, 57T and 46R shares a common time axis, the voltage-magnitude axis of curves 57H and 57T is distinct from the voltage-magnitude axis of curve 46R. Therefore, the placement of curves 57H and 57T above curve 46R is not intended to signify that curves 57H and 57T attain higher amplitudes than does curve 46R.

As shown by the dashed lines in FIG. 9, the high-to-low transition of curve 57H (which indicates that the shoe of the user has impacted with the ground) corresponds with low peak 47R of curve 46R, and the low-to-high transition of curve 57T (which indicates that the shoe of the user has left the ground) corresponds with high peak 49R of curve 46R. Thus, the foot contact time and foot loft time measurements that are obtained, when a user is running, by measuring time differences between high and low peaks, and vice-versa, of the high-pass filtered/amplified output of an accelerometer (mounted as described above) appear to produce results that are at least as accurate as those produced by prior art resistive sensors.

The output signal from accelerometer 34 (shown in FIGS. 4 and 5) is analyzed by microcontroller 40 using two primary software routines: (1) a continuous-loop routine that accumulates data, e.g., foot contact times and foot loft times, pursuant to each iteration of the loop, and (2) an interrupt routine that interrupts the continuous-loop routine and analyzes the data that has been accumulated by the continuous-loop routine at the time the interrupt is initiated. These routines may be written in any software language and preferably are stored in the on-board memory (not shown) of micro-controller 40 (shown in FIGS. 4 and 5). These routines could be user initiated or, preferably, are initiated automatically upon power-up of micro-controller 40. The particular steps performed by each of these primary software routines are described in detail below.

Referring briefly back to FIG. 5, because the voltage at each of inputs 46 and 48 of microcontroller 40 is converted to an 8-bit digital word, the amplitude of the voltage at each input will be represented as one of 256 discrete levels. Also, because resistors R3 and R4 create a voltage at node 60 that is approximately half-way between the high-supply voltage of five volts and the ground, i.e., approximately 2.5 volts, the zero reference at input 48 will remain near the midpoint of the 256 levels, i.e., at approximately level 128.

Referring now to FIG. 10, a high-level flow chart of the continuous-loop routine performed by micro-controller 40 (shown in FIG. 5) is shown. Essentially, continuous-loop portion 101 continuously monitors the voltage across inputs 46 and 48 of micro-controller 40 to determine when negative and positive voltages differences (between inputs 46 and 48) in excess of predetermined thresholds occur. These negative and positive voltage differences are indicative, respectively, of the foot of a user impacting with and leaving the ground.

As shown in FIG. 10, continuous-loop 101 includes steps 100, 102, 104, 106, 108, 110, 112 and 114. Many of these high-level steps include several lower-level sub-steps, which will be described in detail below in connection with the description of FIG. 12.

During step 100 of loop 101, micro-controller 40 continuously monitors the voltages at inputs 46 and 48 to

determine when the voltage at input **46** falls to more than a particular voltage below the voltage at input **48**. According to one embodiment, a voltage at input **46** that is more than 50 levels (of the 256 possible voltage levels) lower than the zero reference level at input **48** is considered a “negative spike event” and the software assumes that the user’s foot has impacted with the ground at the moment the negative spike event occurs. The occurrence of a negative spike event causes an “air time” (Ta) timer in micro-controller **40** to stop and a “contact time” (Tc) timer to start. The time measured by the air time (Ta) timer represents the time difference between the last “positive spike event” (defined below) and the negative spike event just detected. When a negative spike event occurs, a “StepCount” value, i.e., a counted number of footsteps of the user, also is incremented.

Next, during step **102**, the three most recent air times (i.e., air time (Ta) values), which were calculated previously and stored in memory, are subjected to a technique known as FIFO smoothing, which serves to eliminate air time (Ta) measurements that appear to be erroneous. The routine used to perform this FIFO smoothing is described in detail below.

During step **104**, a running total of air time (Ta) values (TaSum) is incremented by the most recently available air time (Ta) value and the total number of air time (Ta) values included in the current TaSum value (TaSteps) is incremented by one. These values are maintained so that an average air time (Ta) value (TaAverage) may eventually be calculated by dividing the TaSum value by the TaSteps value.

During step **106**, which is performed after steps **100**, **102** and **104** are performed, the system “sleeps” for a period of time equal to a minimum possible foot contact time (Tc) for a user, e.g., **122** milli-seconds (ms), so that the system will not think that any positive spikes occurring during this sleep period are a positive spike event (defined below).

Steps **108**, **110**, **112** and **114** are similar to steps **100**, **102**, **104**, and **106**, respectively, except that a foot contact time (Tc), rather than an air time (Ta), is determined.

During step **108** of loop **101**, micro-controller **40** continuously monitors inputs **46** and **48** for a particular voltage difference therebetween. According to one embodiment, a positive voltage at input **46** that is more than 10 levels (of the 256 possible voltage levels) greater than the zero reference level at input **48** is considered a “positive spike event” and the software assumes that the users foot has left the ground at the moment the positive spike event occurs. The occurrence of a positive spike event causes the contact time (Tc) timer to stop and causes the air time (Ta) timer to start. The time measured by the contact time (Tc) timer represents the time difference between the last negative spike event and the positive spike event just detected.

During step **110**, the three most recent contact time (Tc) times, which were calculated previously and stored in memory, are subjected to FIFO smoothing, which serves to eliminate foot contact time (Tc) measurements that appear to be erroneous.

During step **112**, a running total of contact time (Tc) values (TcSum) is incremented by the most recently available contact time (Tc) value and the total number of contact time (Tc) values included in the current TcSum value (TcSteps) is incremented by one. These values are maintained so that an average contact time (Tc) value (TcAverage) may be calculated eventually by dividing the TcSum value by the TcSteps value.

During step **114**, which is performed after steps **108**, **110** and **112** are performed, the system “sleeps” for a period of

time equal to a minimum possible foot contact time for a user so that the system will not think that any negative spikes occurring during this sleep period constitute a negative spike event. After the sleep period of step **114**, the routine returns to step **100** and loop **101** repeats continuously until an interrupt (discussed below) is detected.

Referring now to FIG. **11**, a high-level interrupt routine **1115** now will be briefly explained, with a more detailed description of each high-level step and its associated lower-level sub-steps following below in connection with the description of FIG. **13**.

Interrupt routine **1115** may programmed to run at any given time interval, but preferably should not be run any more frequently than once every two seconds so that meaningful data may be gathered by loop **101** before such data is evaluated by routine **1115**.

Step **1116** of interrupt routine **1115** causes the routine to interrupt continuous-loop **101**. Next, step **1118** calculates the average contact time (Tc) value (TcAverage) over several steps of a user and resets the TcSum and TcSteps values in loop **101** to zero. Similarly, step **1120** calculates the average air time (Ta) value (TaAverage) and resets the TaSum and TaSteps values in loop **101** to zero.

In step **1122**, the step frequency of the user is determined (in a manner described below) based on the calculated TcAverage and TaAverage values, and the total number of steps of the user is calculated by multiplying the StepCount value from loop **101** by two.

Next, in step **1124**, the pace of the user is calculated according to an algorithm described below, and the distance traveled by the user is calculated according to an equation (described below) that uses both the calculated pace value and the time period in which the pace value was determined as variables. This distance measurement could be cumulative of past distance measurements to determine a total distance traveled. The cumulative distance value therefore would be resettable by the user so that the user could measure distance traveled from a zero reference point.

Finally, after the calculations in step **1124**, or any other desired calculations, are performed, step **1126** returns interrupt routine **1115** to the continuous-loop **101** for further measurements of contact time (Tc) and air time (Ta) values.

FIG. **12** shows a lower-level flow chart of continuous-loop **101**. As shown, high-level step **100** (shown in FIG. **10**) includes five lower-level sub-steps **100A–100E**.

In steps **100A** and **100B**, the analog voltages at inputs **46** and **48** of micro-controller **40** are sampled (in step **100A**) until a negative spike event is detected (in step **100B**) in the voltage at input **46** that is indicative of the foot of a user impacting with the ground. According to one embodiment, the analog voltages at inputs **46** and **48** are sampled until the voltage at input **46** falls to less than 50 levels (of a possible 256 discrete voltage levels) below the level of reference input **48**, which should remain approximately at level **128** (i.e., at approximately 2.5 volts on a 5-volt scale). 50 levels corresponds to approximately 0.98 volts on a 5-volt scale. This sampling is done at a rate of 500 samples per second.

The reference level at input **48** may float up or down slightly due to temperature variations of the amplifier circuit, etc. But, because any changes in the reference level at input **48** caused by external factors (such as temperature variations) likely will correspond to changes in the signal level at input **46** due to these factors, the difference between the voltages at nodes **46** and **48** should be affected only by the fluctuating signal generated by the accelerometer, and should not be affected by changes in the operating conditions of the circuit.

11

Once a negative spike event is detected in step 100B, an air time (Ta) timer is stopped (in step 100C) and a foot contact time (Tc) timer is started (in step 100D). The air time (Ta) timer would have been started responsive to the detection of a positive spike event (described below), which is indicative of the foot of the user leaving the ground, during a previous loop of continuous-loop routine 101. Thus, the air time (Ta) timer, when stopped in step 100C, provides a measurement of the air time between footsteps of the user, i.e., the time period between when the foot of the user last left the ground (i.e., the last positive spike event) and when the foot most recently impacted with the ground (i.e., the negative spike event just detected).

In addition, in response to the detection of the negative spike event, the value of the variable StepCount is increased by one (in step 100E). The variable StepCount is reset prior to the user beginning a training regime so that its running total accurately measures the number of footsteps taken by one foot of the user during the training period.

After updating the variable StepCount (in step 100E), continuous-loop 101 proceeds to steps 102A–102E, which are included in “FIFO smoothing” step 100 of the high-level routine shown in FIG. 10. During steps 102A–102E, the three most recent values of air time, i.e., the three most recent air time (Ta) values, which have been stored in memory, are analyzed as follows.

First, during step 102A, the three most recent air time (Ta) values (from prior iterations of loop 101) are shifted to account for the newly-acquired air time (Ta) value (in step 100C). Specifically, the existing third most recent air time (Ta) value is discarded, the existing second most recent air time (Ta) value becomes the new third most recent value, the existing first most recent value becomes the new second most recent value, and the newly-acquired air time (Ta) value becomes the new first most recent air time (Ta) value.

Next, in steps 102B and 102C, the three most recent air time (Ta) values (after being shifted in step 102A) are compared, as described below, to ascertain whether the middle air time (Ta) value (i.e., the second most recent air time (Ta) value) appears to be anomalous. An anomalous air time (Ta) measurement (i.e., an anomalous air time (Ta) value) might occur, for example, when a user steps on a rock or slips on water or ice during a footstep. If the second most recent air time (Ta) value appears to be the result of an erroneous measurement, then (in step 102D) it is replaced with an average of the first and third most recent air time (Ta) values. Thus, because only the third most recent air time (Ta) value is used for all future calculations (according to step 102E), the replacement of anomalous second most recent air time (Ta) values serves to filter or smooth out occasional anomalous measurements.

Specifically, in step 102B, the first and third most recent air time (Ta) values are compared. If these values are within a particular percentage of one another (e.g., if the first most recent air time (Ta) value is 5% greater than or less than the third most recent air time (Ta) value), then the routine proceeds to step 102C. If the first and third air time (Ta) values are not within the particular percentage of one another, then the routine proceeds directly to step 102E. That is, if there is too great a difference between the first and third most recent air time (Ta) measurements, then it is assumed that the user has changed speeds between those two measurements, and to reset the second most recent air time (Ta) value in such a situation likely would result in inaccurate air time (Ta) values, rather than the smoothed values obtained when the first and third most recent air time (Ta) measurements are similar.

12

If step 102C is reached, then the first and second most recent air time (Ta) values are compared. If the first most recent air time (Ta) value is not within a particular percentage of the second most recent air time (Ta) value (e.g., if the first most recent air time (Ta) value is not 5% greater than or less than the second most recent air time (Ta) value), then (in step 102D) the second most recent air time (Ta) value is replaced with an average of the first and third most recent air time (Ta) values, thereby eliminating the apparently anomalous second most recent air time (Ta) measurement.

Finally, according to step 102E, the third most recent air time (Ta) value is used for all future calculations involving air time (Ta) measurements. Thus, because this third most recent air time (Ta) value was a second most recent air time (Ta) value in a previous iteration of loop 101, it would have been “smoothed” during that iteration had it appeared anomalous based upon the comparisons done in steps 102B and 102C above.

High-level step 104 (shown in FIG. 10) includes sub-steps 104A and 104B. As shown in FIG. 12, in step 104A, a cumulative total of air time (Ta) measurements (TaSum) from past iterations of loop 101 is updated with the third most recent air time (Ta) value from step 102E to obtain an updated value of TaSum (i.e., $TaSum = TaSum + Ta$).

Next, in step 104B, a running total of the number of air time (Ta) steps (TaSteps) is incremented by one (i.e., $TaSteps = TaSteps + 1$). An air time step occurs each time that a positive spike event (identified in step 108B, described below) is followed by a negative spike event (identified in step 100B).

In step 106 of loop 101, the system is put in a sleep-mode for a particular amount of time before proceeding to step 108A. According to one embodiment, this sleep mode lasts for a time equal to the minimum foot contact time (Tc) that might occur when a user is running at a maximum rate of speed (e.g., 122 milliseconds (ms)). This sleep period is used to prevent the micro-controller from falsely identifying the ringing that occurs in the accelerometer output signal immediately following a detected negative spike event as a subsequent positive spike event. In addition, the power supply to non-critical components in the circuit may be lowered or eliminated during the sleep period to conserve power in the system.

After the sleep period of step 106, loop 101 proceeds to steps 108A–108E, which constitute high-level step 108 (shown in FIG. 10). In steps 108A and 108B, the analog voltages at inputs 46 and 48 of micro-controller 40 are sampled (in step 108A) until a positive spike event is detected (in step 108B) in the voltage at input 46 that is indicative of the foot of a user leaving the ground. According to one embodiment, the analog voltages at inputs 46 and 48 are sampled until the voltage at input 46 rises to greater than 10 levels (of a possible 256 discrete voltage levels) above the level of reference input 48, which should remain approximately at level 128 (i.e., at approximately 2.5 volts on a 5-volt scale). 10 levels corresponds to approximately 0.20 volts on a 5-volt scale. This sampling is done at a rate of 500 samples per second.

Once a positive spike event is detected in step 108B, the foot contact time (Tc) timer is stopped (in step 108C) and the foot air time (Ta) timer is started (in step 108D). The contact time (Tc) timer would have been started (in step 100D) responsive to the detection of a negative spike event (in step 110B) during a previous loop of continuous-loop routine 101. Thus, the contact time (Tc) timer, when stopped in step 108C, provides a measurement of the foot contact time of a

13

user during a footstep of the user, i.e., the time period during which the foot of the user is in physical contact with the ground during a footstep.

In step 108E, the time measured by the contact time (Tc) timer is evaluated to determine whether it falls within an acceptable range of foot contact times. If the measured contact time (Tc) value is not within this acceptable range, then the routine returns to step 100A for the identification of another negative spike event. According to one embodiment, an acceptable range of foot contact times is between 140 and 900 ms.

After evaluating the measured contact time (Tc) value (in step 108E), continuous-loop 101 proceeds to steps 110A–110E, which are included in “FIFO smoothing” step 110 of the high-level routine shown in FIG. 10. During steps 110A–110E, the three most recent foot contact time values, i.e., the three most recent contact time (Tc) values, which have been stored in memory, are analyzed as follows.

First, during step 110A, the three most recent contact time (Tc) values (from prior iterations of loop 101) are shifted to account for the newly-acquired contact time (Tc) value (in step 108C). Specifically, the existing third most recent contact time (Tc) value is discarded, the existing second most recent contact time (Tc) value becomes the new third most recent value, the existing first most recent value becomes the new second most recent contact time (Tc) value, and the newly-acquired contact time (Tc) value becomes the new first most recent contact time (Tc) value.

Next, in steps 110B and 110C, the three most recent contact time (Tc) values (after being shifted in step 110A) are compared, as described below, to ascertain whether the middle contact time (Tc) value (i.e., the second most recent contact time (Tc) value) appears to be anomalous. An anomalous contact time (Tc) measurement (i.e., an anomalous contact time (Tc) value) might occur, for example, when a user steps on a rock or slips on water or ice during a footstep. If the second most recent contact time (Tc) value appears to be the result of an erroneous measurement, then (in step 110D) it is replaced with an average of the first and third most recent contact time (Tc) values. Thus, because only the third most recent contact time (Tc) value is used for all future calculations (according to step 110E), the replacement of anomalous second most recent contact time (Tc) values serves to filter or smooth out occasional anomalous measurements.

Specifically, in step 110B, the first and third most recent contact time (Tc) values are compared. If these values are within a particular percentage of one another (e.g., if the first most recent contact time (Tc) value is 5% greater than or less than the third most recent contact time (Tc) value), then the routine proceeds to step 110C. If the first and third most recent contact time (Tc) values are not within the particular percentage of one another, then the routine proceeds directly to step 110E. That is, if there is too great a difference between the first and third most recent contact time (Tc) measurements, then it is assumed that the user has changed pace between those two measurements, and to reset the second most recent contact time (Tc) value in such a situation likely would result in an inaccuracy, rather than the smoothed values obtained when the first and third most recent contact time (Tc) measurements are similar.

If step 110C is reached, then the first and second most recent contact time (Tc) values are compared. If the first most recent contact time (Tc) value is not within a particular percentage of the second most recent contact time (Tc) value (e.g., if the first most recent contact time (Tc) value is not 5%

14

greater than or less than the second most recent contact time (Tc) value), then (in step 110D) the second most recent contact time (Tc) value is replaced with an average of the first and third most recent contact time (Tc) values, thereby eliminating the apparently anomalous second most recent contact time (Tc) measurement.

Finally, according to step 110E, the third most recent contact time (Tc) value is used for all future calculations involving foot contact time (Tc) measurements. Thus, because this third most recent contact time (Tc) value was a second most recent contact time (Tc) value in a previous iteration of loop 101, it would have been “smoothed” during that iteration had it appeared anomalous based upon the comparisons done in steps 110B and 110C above.

Although not shown in FIG. 12, the measured foot contact time also could be used to determine a moment that the user’s foot is in its “zero position” during each stride taken by the user, i.e., a moment that the bottom surface of the user’s foot is parallel to the surface on which the user is walking, jogging or running. This moment could be determined, for example, by assuming that the user’s foot is in its zero position mid-way (or a particular percentage-way) through the measured foot contact time for each stride.

High-level step 112 (shown in FIG. 10) includes sub-steps 112A and 112B. As shown in FIG. 12, in step 112A, a cumulative total of contact time (Tc) measurements (TcSum) from past iterations of loop 101 is updated with the third most recent contact time (Tc) measurement from step 110E to obtain an updated value of the variable TcSum (i.e., $TcSum = TcSum + Tc$).

Next, in step 112B, a running total of the number of foot contact time (Tc) steps (TcSteps) is incremented by one (i.e., $TcSteps = TcSteps + 1$). An foot contact time step (TcStep) occurs each time that a negative spike event (identified in step 100B) is followed by a positive spike event (identified in step 108B), described above.

In step 114 of loop 101, the system is put in a sleep-mode for a particular amount of time before returning to step 100A. According to one embodiment, this sleep mode lasts for a time equal to the minimum foot contact time (Tc) that might occur when a user is running at a maximum rate of speed (e.g., 122 ms). This sleep period is used to prevent the micro-controller from falsely identifying the ringing that occurs in the accelerometer output signal immediately following a detected positive spike event as a subsequent negative spike event. In addition, the power supply to non-critical components in the circuit may be lowered or eliminated during the sleep period to conserve power in the system.

FIG. 13 shows a lower-level flow chart of interrupt routine 115. As mentioned previously, interrupt routine 115 periodically interrupts continuous-loop 101 so that it may evaluate and analyze the data accumulated by multiple iterations of the loop, e.g., foot contact times and foot lift times. Interrupt routine 115 may be programmed to run at any given time interval, but preferably should not be run any more frequently than once every two seconds so that meaningful data may be gathered by loop 101 before such data is analyzed and evaluated by routine 115.

Step 116 of interrupt routine 115 causes the routine to interrupt continuous-loop 101. Next, steps 118A–118D, which constitute high-level step 118 in FIG. 11, calculate the average contact time (Tc) value (TcAverage) over several steps of a user and reset the TcSum and TcSteps values in loop 101 to zero. Specifically, steps 118A and 118B, respectively, evaluate the current values of TcSteps and

15

TcSum to make sure that each of them is greater than zero. This is done to prevent the micro-controller from performing any divisions by a value of zero. Next, in step 118C, an average foot contact time value (TcAverage) is calculated by dividing the value of TcSum by the value of TcSteps (i.e., $TcAverage = TcSum / TcSteps$, wherein “/” is the division operator). Finally, the values of TcSum and TcSteps are reset to zero (in step 118D) so that fresh measurements of foot contact times may be made upon return to continuous-loop 101.

Similarly, steps 120A–120D, which constitute high-level step 120 in FIG. 11, calculate the average air time (Ta) value (TaAverage) over several steps of a user and reset the TaSum and TaSteps values in loop 101 to zero. Specifically, steps 120A and 120B, respectively, evaluate the current values of TaSteps and TaSum to make sure that each of them is greater than zero. Next, in step 120C, an average foot air time value (TaAverage) is calculated by dividing the value of TaSum by the value of TaSteps (i.e., $TaAverage = TaSum / TaSteps$). Finally, the values of TaSum and TaSteps are reset to zero (in step 120D) so that fresh measurements of foot air times may be made upon return to continuous-loop 101.

In steps 122A–122C, which constitute high-level step 122 in FIG. 11, the step frequency of the user is determined based on the calculated TcAverage and TaAverage values, and the total number of steps of the user is calculated by multiplying the StepCount value from loop 101 by two. Specifically, step 122A evaluates the current value of TcAverage to make sure that it is greater than zero. This is done to prevent the micro-controller from performing any divisions by a value of zero. Next, in step 122B, the step frequency of the user is calculated by taking the inverse of two times the average air time value (TaAverage) plus the average foot contact time value (TcAverage) (i.e., $Step\ Frequency = 2 * (1 / (TaAverage + TcAverage))$, wherein “*” is the multiplication operator).

Next, in steps 124A–124E, the pace of the user (Pace) is calculated according to a known algorithm (described below), and the distance traveled by the user is calculated by multiplying the time period in which the pace was determined by the rate at which the user is moving. The rate of the user (in feet-per-second) is equal to the quantity $(5280 / (Pace * 60))$. This distance measurement could be cumulative of past distance measurements to determine a total distance traveled. The cumulative distance value, therefore, would be resettable by a user so the user could measure distance traveled from a zero reference point.

Specifically, in step 124A, the average foot contact time value (TcAverage), which was calculated in step 118C, is evaluated to determine whether it is greater than or less than 400 ms. If TcAverage is less than 400 ms, then a variable “Slope” is set (in step 124B) to a value of 24, and if TcAverage is greater than 400 ms, then the variable Slope is set (in step 124C) to a value of 28.5. Next, in step 124D, the pace of the user (Pace) is calculated by multiplying the value TcAverage by the variable Slope (i.e., $Pace = TcAverage * Slope$).

The present inventors have discovered that it is advantageous to use at least two distinct equations to derive the pace of the user based upon the measured foot contact time. That is, for a measured foot contact time that is less than a particular value (e.g., 400 ms), a first equation should be used to derive the pace of the user therefrom, while for a measured foot contact time that is greater than the particular value (e.g., 400 ms), a second equation should be used.

Referring to FIG. 14, a graph showing the discovered relationship between foot contact time (Tc) and the pace of

16

a user (Pace) is provided. As shown, curve 90 has distinct segments 90A, 90B and 90C. Each of line segments 90A and 90C has a different slope, but both share a common y-intercept value at zero minutes-per-mile. It has been discovered that the average foot contact time of a user does not tend to fall within the range covered by line segment 90B, regardless of whether the user is walking, jogging or running. Therefore, one of line segments 90A or 90C may always be used to determine a pace of the user based upon the measured foot contact time. As shown in FIG. 14, the slope of line segment 90A is 24. This slope is used as the variable Slope (in Step 124B of FIG. 13) when the average measured foot contact time falls under line segment 90A, i.e., when TcAverage is less than 400 ms. Similarly, the slope of line segment 90C is 28.5, and this slope is used as the variable Slope (in step 124C of FIG. 13) when the average measured foot contact time falls under line segment 90C, i.e., when TcAverage is greater than 400 ms.

Referring again to FIG. 13, in step 124E, the distance traveled by a user in locomotion (Distance), as mentioned above, is calculated using the following equation: $Distance = (time * (5280 / (Pace * 60)))$, wherein “time” is the interrupt period of interrupt routine 115 (e.g., two or more seconds).

Finally, after the calculations in steps 124A–E, and/or any other desired calculations, are performed, step 126 returns interrupt routine 115 to continuous-loop 101 for further measurements of contact time (Tc) and air time (Ta) values.

In addition to calculating a user’s pace, rate of travel, and distance traveled, metabolic energy expenditure may also be calculated based upon the measured foot contact time of a user. One approach to measuring metabolic energy expenditure based upon foot contact time is described by two of the inventors of the present invention in co-pending U.S. patent application Ser. No. 08/255,820, filed on Apr. 11, 1994, which is incorporated herein by reference.

Referring briefly back to FIGS. 1 and 3, according to one embodiment, several variables or parameters could be input by the user for use by the software routine described above. These variables or parameters could be input, for example, via user interface 32 in FIG. 1 or user interface 58 in FIG. 3. Although the present invention is intended to be completely self-adjusting and ideally should not require the input of any user-specific data, it is envisioned that certain parameters and variables may be user-adjustable to accommodate individual users. For example: (1) the threshold values for the positive and negative spike events (identified in steps 108B and 100B, respectively, of FIG. 12) could be adjusted, (2) the sleep times of steps 106 and 114 of FIG. 12 could be adjusted, (3) the slopes of the various portions of line segment 90 (in FIG. 14) could be adjusted or additional line segments could be added or alternative contact time/pace equations could be employed in their stead, or (4) the acceptable range of foot contact time (Tc) values determined in step 108E of FIG. 12 could be altered.

Such parameters or variables could have default values pre-programmed into the system, which default values could then be adjusted by the user according to certain user-specific criteria such as height, weight, or shoe hardness. Alternatively, the parameters or variables could be adjusted automatically via software, based upon information input by the user (such as the pushing of a button both when the user starts and when the user finishes traversing a known distance).

It should be understood that while the invention has been described herein as using a particular accelerometer and a particular micro-controller to perform its various functions,

17

any devices performing similar functions, including hard-wired circuitry, could equivalently be employed without departing from the intended scope of the invention. Additionally, while a specific embodiment of a high-pass filter/amplifier circuit is described herein, the scope of the invention is not intended to be limited by the particular characteristics of this embodiment. Further, while a highly-specific software routine has been described herein, the particular characteristics of this routine should also not be regarded as limiting the scope of the invention.

Having thus described at least one illustrative embodiment of the invention, various alterations, modifications and improvements will readily occur to those skilled in the art. Such alterations, modifications and improvements are intended to be within the spirit and scope of the invention. Accordingly, the foregoing description is by way of example only and is not intended as limiting. The invention is limited only as defined in the following claims and the equivalents thereto.

What is claimed is:

1. A method for analyzing motion of a foot of a person relative to a surface, comprising steps of:
 - (a) using an accelerometer that does not require compression forces thereon to sense acceleration to sense an acceleration of the foot and to provide a signal indicative of the acceleration of the foot;
 - (b) providing the signal from the accelerometer to a signal processor; and
 - (c) using the signal processor to analyze the signal to determine a moment that the foot leaves the surface during a footstep taken by the person.
2. The method as recited in claim 1, wherein the accelerometer has an acceleration sensing direction, and wherein the step (a) includes a step of:
 - (a1) orienting the accelerometer with respect to the foot such that the acceleration sensing direction of the accelerometer is not oriented perpendicular to a bottom surface of the foot.
3. The method as recited in claim 2, wherein the step (a1) includes a step of orienting the accelerometer with respect to the foot such that the acceleration sensing direction of the accelerometer is substantially parallel to the bottom surface of the foot.
4. The method as recited in claim 1, wherein the step (c) includes a step of:
 - (c1) using the signal processor to identify a characteristic in the signal that is indicative of the foot leaving the surface.
5. The method as recited in claim 4, wherein the step (c1) includes a step of using the signal processor to identify a high level or a low level in the signal that is indicative of the foot leaving the surface.
6. The method as recited in claim 5, further comprising a step of frequency-filtering the signal prior to identifying the high level or the low level.
7. The method as recited in claim 6, further comprising a step of amplifying the signal prior to identifying the high level or the low level.
8. The method as recited in claim 4, further comprising a step of high-pass frequency-filtering the signal prior to identifying the characteristic in the signal.
9. A method for analyzing motion of a foot of a person relative to a surface, comprising steps of:
 - (a) using an output of an accelerometer that does not require compression forces thereon to sense acceleration to determine a moment that the foot of the person leaves the surface during a footstep taken by the person; and

18

(b) using the output of the accelerometer to determine a moment that the foot comes into contact with the surface.

10. The method as recited in claim 9, further comprising a step of:
 - (c) determining a foot contact time based upon a time difference between the moment that the foot comes into contact with the surface determined in the step (b) and the moment that the foot leaves the surface determined in the step (a).
11. The method as recited in claim 10, wherein the step (c) includes a step of waiting for a predetermined period of time after step (b) is performed to perform step (a).
12. The method as recited in claim 10, further comprising steps of:
 - (d) repeating the steps (a), (b) and (c) to determine a plurality of foot contact times; and
 - (e) averaging the plurality of foot contact times determined in the step (d) to determine an average foot contact time.
13. The method as recited in claim 12, wherein the step (d) includes a step of:
 - (d1) ignoring any of the plurality of foot contact times that are not within a predetermined range of acceptable foot contact times.
14. The method as recited in claim 12, further comprising a step of:
 - (f) using the average foot contact time determined in the step (e) to determine a rate at which the person is moving relative to the surface.
15. The method as recited in claim 14, wherein the step (f) includes steps of:
 - (f1) if the average foot contact time is less than a first amount of time, then deriving the rate at which the person is moving according to a first equation in which the average foot contact time is a factor; and
 - (f2) if the average foot contact time is greater than a second amount of time, then deriving the rate at which the person is moving according to a second equation in which the average foot contact time is a factor.
16. The method as recited in claim 14, further comprising steps of:
 - (g) measuring a time interval that the person is in locomotion; and
 - (h) determining a distance that the person has traveled by multiplying the rate at which the person is moving determined in the step (f) by the time interval measured in the step (g).
17. The method as recited in claim 10, further comprising steps of:
 - (d) repeating the steps (a), (b) and (c) to determine and store in memory a plurality of most recent foot contact times, including a first most recent contact time, a second most recent contact time and a third most recent contact time; and
 - (e) if the first most recent contact time is within a first percentage range greater than or less than the third most recent contact time, and if the first most recent contact times is not within a second percentage range greater than or less than the second most recent contact time, then setting the second most recent contact time to an average of the first most recent contact time and the third most recent contact time.
18. The method as recited in claim 9, further comprising a step of:

19

(a) determining a foot loft time based upon a time difference between the moment that the foot leaves the surface determined in the step (a) and the moment that the foot comes into contact with the surface determined in the step (b).

19. The method as recited in claim 18, wherein the step (c) includes a step of waiting for a predetermined period of time after step (a) is performed to perform step (b).

20. The method as recited in claim 18, further comprising steps of:

(d) repeating the steps (a), (b) and (c) to determine a plurality of foot loft times; and

(e) averaging the plurality of foot loft times determined in the step (d) to determine an average foot loft time.

21. The method as recited in claim 18, further comprising steps of:

(d) repeating the steps (a), (b) and (c) to determine and store in memory a plurality of most recent foot loft times, including a first most recent loft time, a second most recent loft time and a third most recent loft time;

(e) if the first most recent loft time is within a first percentage range greater than or less than the third most recent loft time, and if the first most recent loft times is within a second percentage range greater than or less than the second most recent loft time, then setting the second most recent loft time to an average of the first most recent loft time and the third most recent loft time.

22. A method for determining a rate that a person is moving on foot relative to a surface comprising steps of:

(a) determining a foot contact time of the person in locomotion; and

(b) if the foot contact time is less than a first amount of time, then deriving the rate at which the person is moving according to a first equation in which the foot contact time is a factor; and

(c) if the foot contact time is greater than a second amount of time, which is greater than the first amount of time, then deriving the rate at which the person is moving according to a second equation in which the foot contact time is a factor.

23. A device for analyzing motion of a foot of a person relative to a surface, comprising:

an accelerometer supported in relation to the foot, the accelerometer being configured and arranged to provide an output signal indicative of motion of the foot during at least one footstep taken by the person without requiring compression forces thereon to sense motion; and

a signal processor coupled to the accelerometer to receive the output signal therefrom, the signal processor being configured to analyze the output signal of the accelerometer to determine at least one moment that the foot leaves the surface during the at least one footstep.

24. The device for analyzing motion of a foot relative to a surface as claimed in claim 23, wherein the signal processor is configured to analyze the output signal of the accelerometer to determine at least one moment that the foot makes contact with the surface.

25. The device for analyzing motion of a foot relative to a surface as claimed in claim 24, wherein the signal processor is configured to analyze the output signal of the accelerometer to determine at least one time period that the foot was in contact with the surface during at least one stride taken by the foot based upon a time difference between the at least one moment that the foot came into contact with the surface and the at least one moment that the foot left the surface.

20

26. The device for analyzing motion of a foot relative to a surface as claimed in claim 24 wherein, the signal processor is configured to analyze the output signal of the accelerometer to determine at least one time period that the foot was not in contact with the surface between strides taken by the foot based upon a time difference between the at least one moment that the foot left the surface and the at least one moment that the foot came into contact with the surface.

27. The device for analyzing motion of a foot relative to a surface as claimed in claim 23, wherein the signal processor is configured to analyze the output signal of the accelerometer to determine time periods that the foot was in contact with the surface during strides taken by the foot or to determine time periods that the foot was not in contact with the surface between strides taken by the foot.

28. The device for analyzing motion of a foot relative to a surface as claimed in claim 23, wherein the signal processor includes a high-pass filter arranged to filter the output signal of the accelerometer before the output signal is analyzed.

29. The device for analyzing motion of a foot relative to a surface as claimed in claim 28, wherein the signal processor includes an amplifier arranged to amplify the output signal before the output signal is analyzed.

30. A device for determining a rate at which a person in locomotion is moving on foot, comprising:

a signal processor adapted to receive information regarding at least one foot contact time, the signal processor being configured such that:

if the at least one foot contact time is less than a first amount of time, then the signal processor derives the rate at which the person is moving according to a first equation in which the at least one foot contact time is a factor; and

if the at least one foot contact time is greater than a second amount of time, which is greater than the first amount of time, then the signal processor derives the rate at which the user is moving according to a second equation in which the at least one foot contact time is a factor.

31. A method for monitoring activity of a person in locomotion on foot, comprising steps of:

(a) using a first electronic device to determine at least one foot contact time of the person;

(b) using the first electronic device to calculate a rate at which the person is moving relative to a surface based upon the at least one foot contact time determined in the step (a); and

(c) transmitting information, which is based upon the rate calculated in the step (b), from the first electronic device to a second electronic device via a wireless communication channel.

32. The method as claimed in claim 31, further comprising a step of:

(d) using the second electronic device to display a variable which is based upon the information transmitted in the step (c).

33. The method as claimed in claim 32, wherein the step (d) includes a step of:

(d1) using the second electronic device to display the rate calculated in the step (b).

34. A system for monitoring activity of a person in locomotion on foot, comprising:

a first electronic device to measure at least one foot contact time of the person and to calculate a rate at

21

which the person is moving relative to a surface based upon the at least one foot contact time; and
a second electronic device, coupled to the first electronic device via a wireless communication channel, to receive information from the first electronic device over the wireless communication channel which is based upon the rate calculated by the first electronic device.

35. The system as claimed in claim **34**, wherein: the second electronic device includes a display to display a variable which is based upon the information received from the first electronic device over the wireless communication channel.

36. The system as claimed in claim **35**, wherein the second electronic device is configured to display the rate calculated by the first electronic device.

37. A method for analyzing motion of a foot of a person relative to a surface, comprising steps of:

- (a) using an accelerometer located entirely above a bottom surface of the foot to sense acceleration of the foot and to provide a signal indicative of acceleration of the foot;

22

(b) providing the signal from the accelerometer to a signal processor; and

(c) using the signal processor to analyze the signal to determine a moment that the foot leaves the surface during a footstep taken by the person.

38. A device for analyzing motion of a foot of a person relative to a surface, comprising:

an accelerometer supported by the person, the accelerometer being located above a bottom surface of the foot and configured and arranged to provide an output signal indicative of acceleration of the foot during at least one footstep taken by the person; and

a signal processor coupled to the accelerometer to receive the output signal therefrom, the signal processor being configured to analyze the output signal of the accelerometer to determine at least one moment that the foot leaves the surface during the at least one footstep.

* * * * *

UNITED STATES PATENT AND TRADEMARK OFFICE
CERTIFICATE OF CORRECTION

PATENT NO. : 6,018,705
DATED : January 25, 2000
INVENTOR(S) : Paul J. Gaudet, Thomas P. Blackadar and Steven R. Oliver

It is certified that error appears in the above-identified patent and that said Letters Patent is hereby corrected as shown below:

IN THE CLAIMS

Column 18, line 46, please replace "nultiplied" with --multiplying--.

Column 19, line 1, please replace "(a)" with --(c)--.

Signed and Sealed this
Ninth Day of January, 2001



Attest:

Q. TODD DICKINSON

Attesting Officer

Commissioner of Patents and Trademarks

UNITED STATES PATENT AND TRADEMARK OFFICE
CERTIFICATE OF CORRECTION

PATENT NO. : 6,018,705
APPLICATION NO. : 08/942802
DATED : January 25, 2000
INVENTOR(S) : Paul J. Gaudet et al.

Page 1 of 1

It is certified that error appears in the above-identified patent and that said Letters Patent is hereby corrected as shown below:

In Column 17, Claim 6, Line 52:

Please delete "as-recited" and insert --as recited--.

In Column 18, Claim 16, Line 48:

Please delete "multiplying" and insert --multiplying--.

Signed and Sealed this

Thirteenth Day of October, 2009

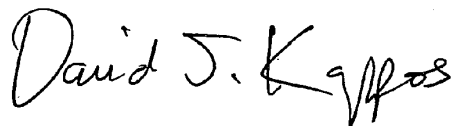

David J. Kappos
Director of the United States Patent and Trademark Office



US005636146A

United States Patent [19]
Flentov et al.

[11] **Patent Number:** **5,636,146**
[45] **Date of Patent:** **Jun. 3, 1997**

[54] **APPARATUS AND METHODS FOR DETERMINING LOFT TIME AND SPEED**

[75] **Inventors:** Peter Flentov, Boston; Dennis M. Darcy, Dracut; Curtis A. Vock, Salem, all of Mass.

[73] **Assignee:** PhatRat Technology, Inc., Carlisle, Mass.

[21] **Appl. No.:** 344,485

[22] **Filed:** Nov. 21, 1994

[51] **Int. Cl.⁶** G04F 10/00

[52] **U.S. Cl.** 364/569; 364/565; 368/10

[58] **Field of Search** 364/569, 565; 377/20, 23, 24.1, 24.2, 5, 9; 482/71, 74, 902; 235/105; 346/33 R; 324/160; 280/DIG. 13; 368/10

[56] **References Cited**

U.S. PATENT DOCUMENTS

3,978,725	9/1976	Hadtke	73/182
4,089,057	5/1978	Eriksson	364/562
4,371,945	2/1983	Karr et al.	377/24.2
4,722,222	2/1988	Purdy et al.	324/160

4,757,714	7/1988	Purdy et al.	73/597
5,295,085	3/1994	Hoffacker	364/558
5,343,445	8/1994	Cherdak	368/10
5,452,269	9/1995	Cherdak	368/10

Primary Examiner—Emanuel T. Voeltz
Assistant Examiner—Hal D. Wachsman
Attorney, Agent, or Firm—Curtis A. Vock

[57] **ABSTRACT**

The invention detects the loft time and/or speed of a vehicle, such as a sporting vehicle, during activities of moving and jumping. A loft sensor detects when the vehicle leaves the ground and when the vehicle returns to the ground. A microprocessor subsystem converts the sensed information to determine a loft time. A display shows the recorded loft time to a user of the system. In addition, a speed sensor can detect the vehicle's speed for selective display to the user. The invention can be used, for example, in sporting activities such as snowboarding where users loft into the air on ski jumps and catch "air" time but have no quantitative measure of the actual time lapse in the air. Therefore, users in skiing can use invention to record, store, and playback selected information relating to their sporting day, including the total amount of "air" time for the day and information such as dead time, i.e., time not spent on the slopes.

16 Claims, 16 Drawing Sheets

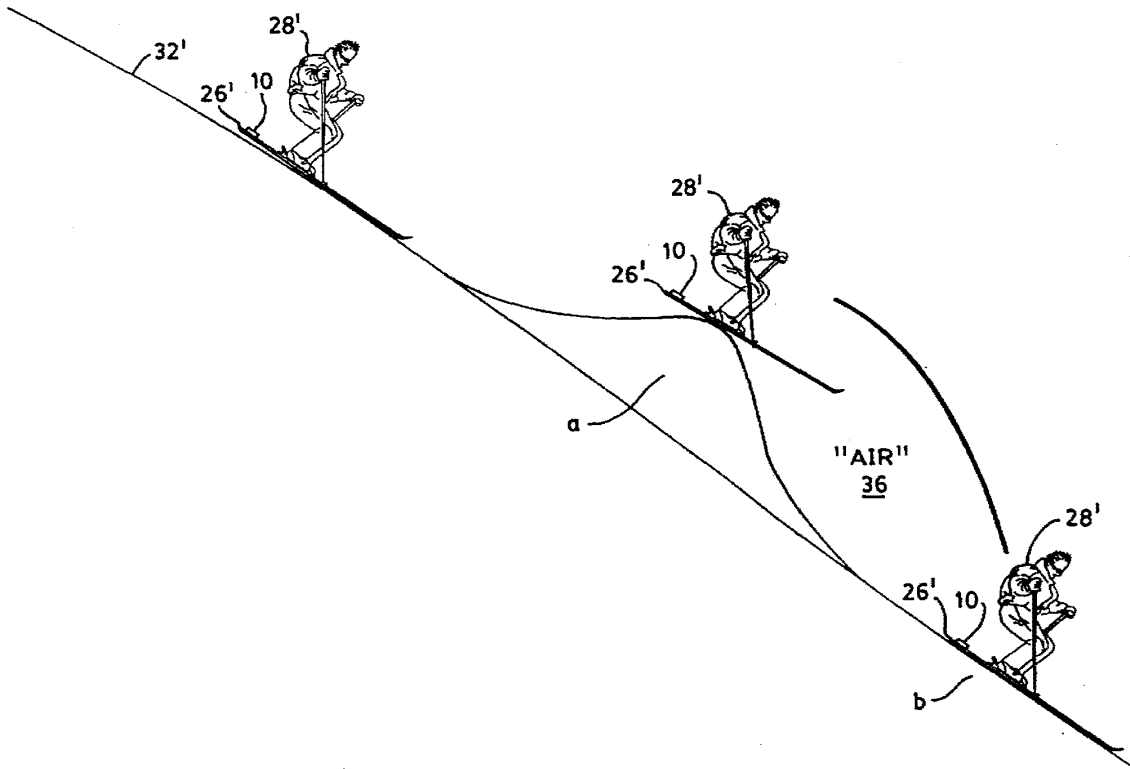

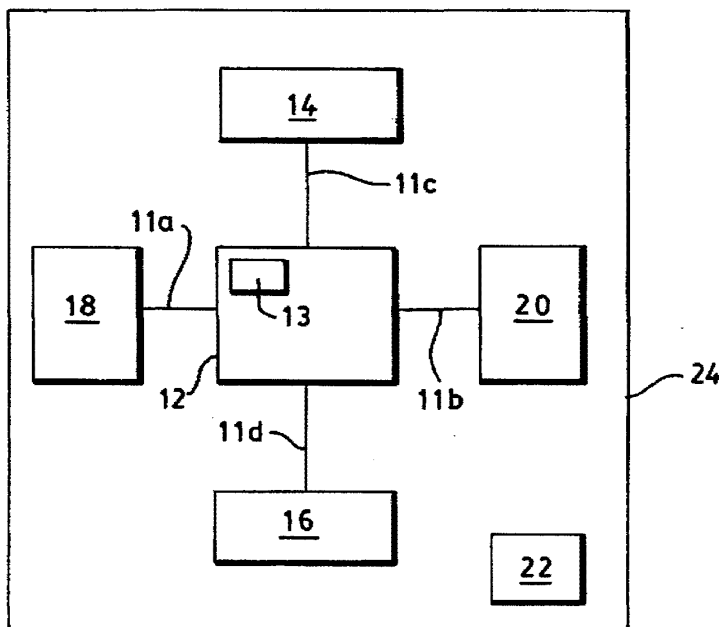
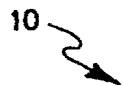

FIG. 1

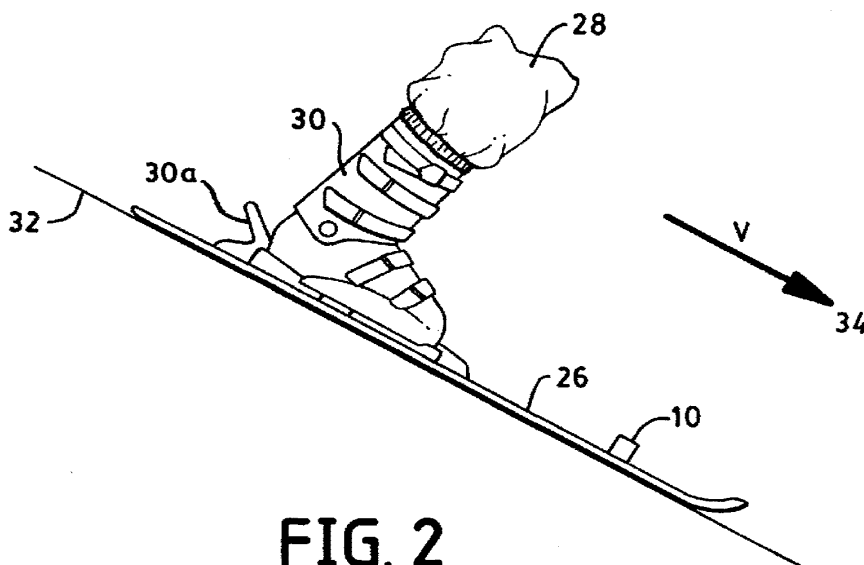

FIG. 2

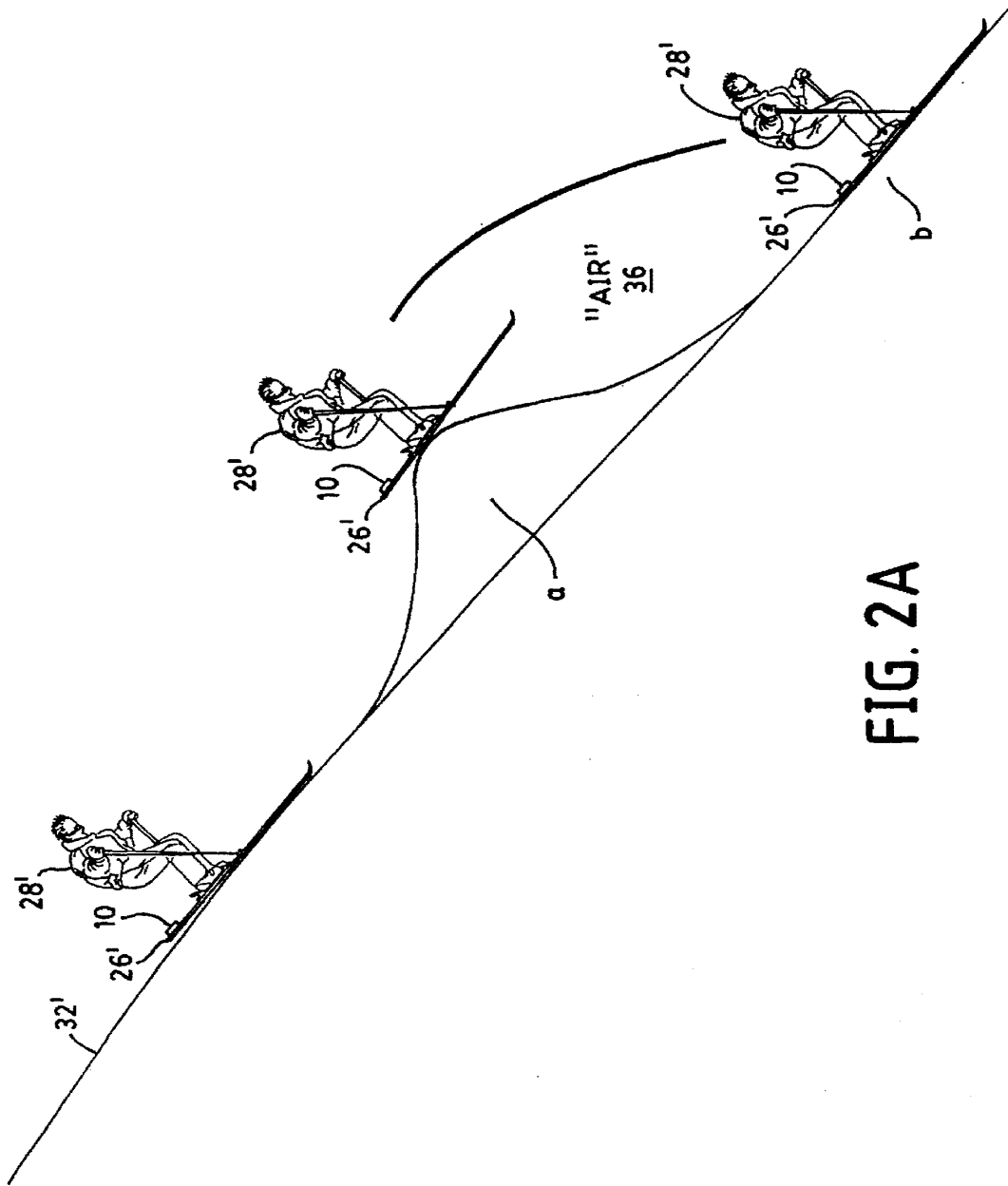

FIG. 2A

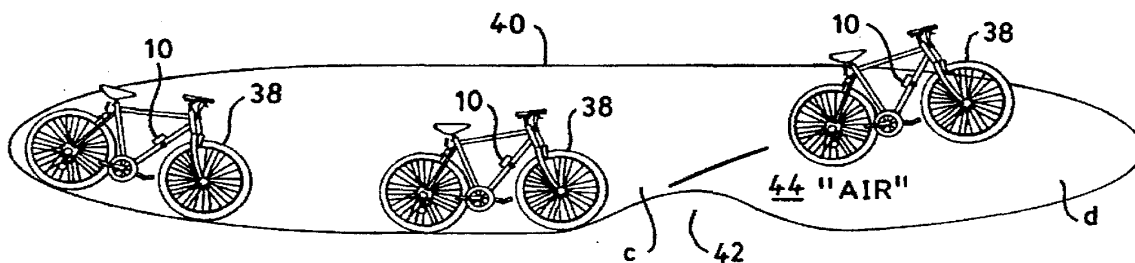

FIG. 2B

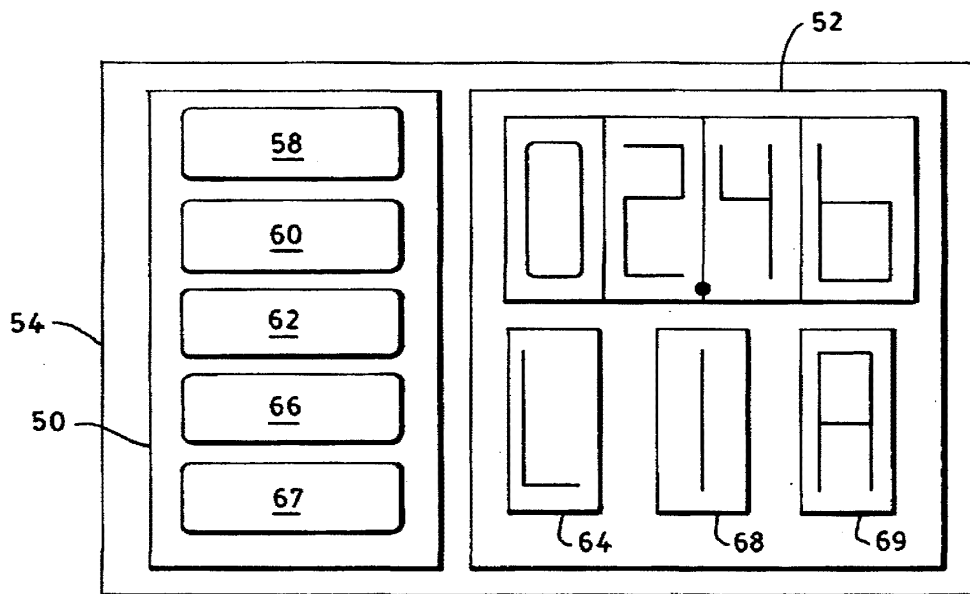

FIG. 3

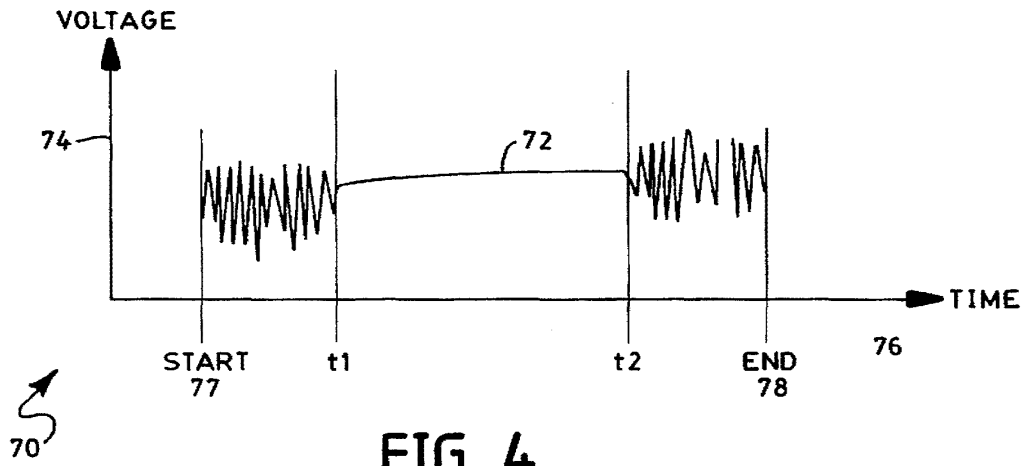

FIG. 4



FIG. 5

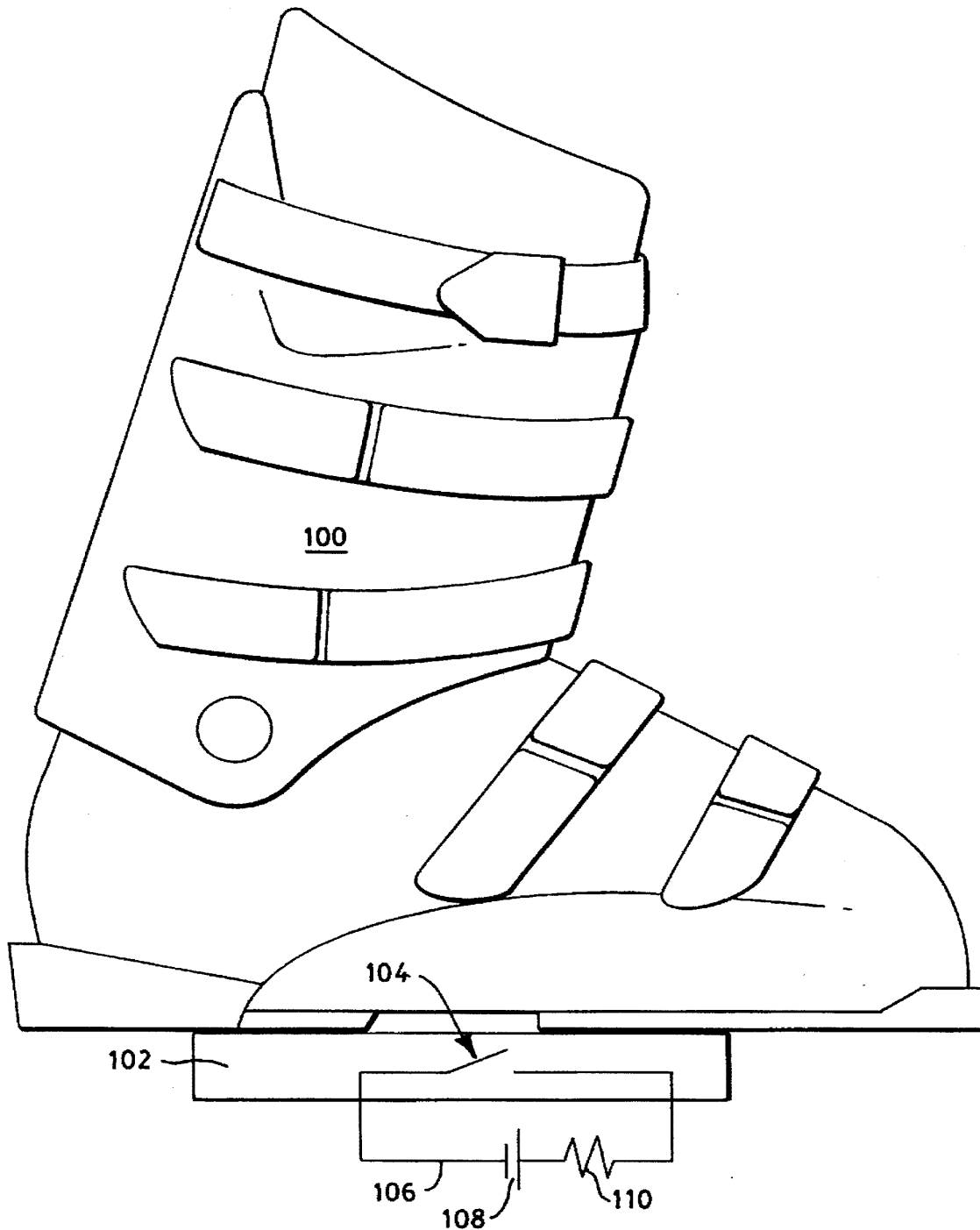

FIG. 6

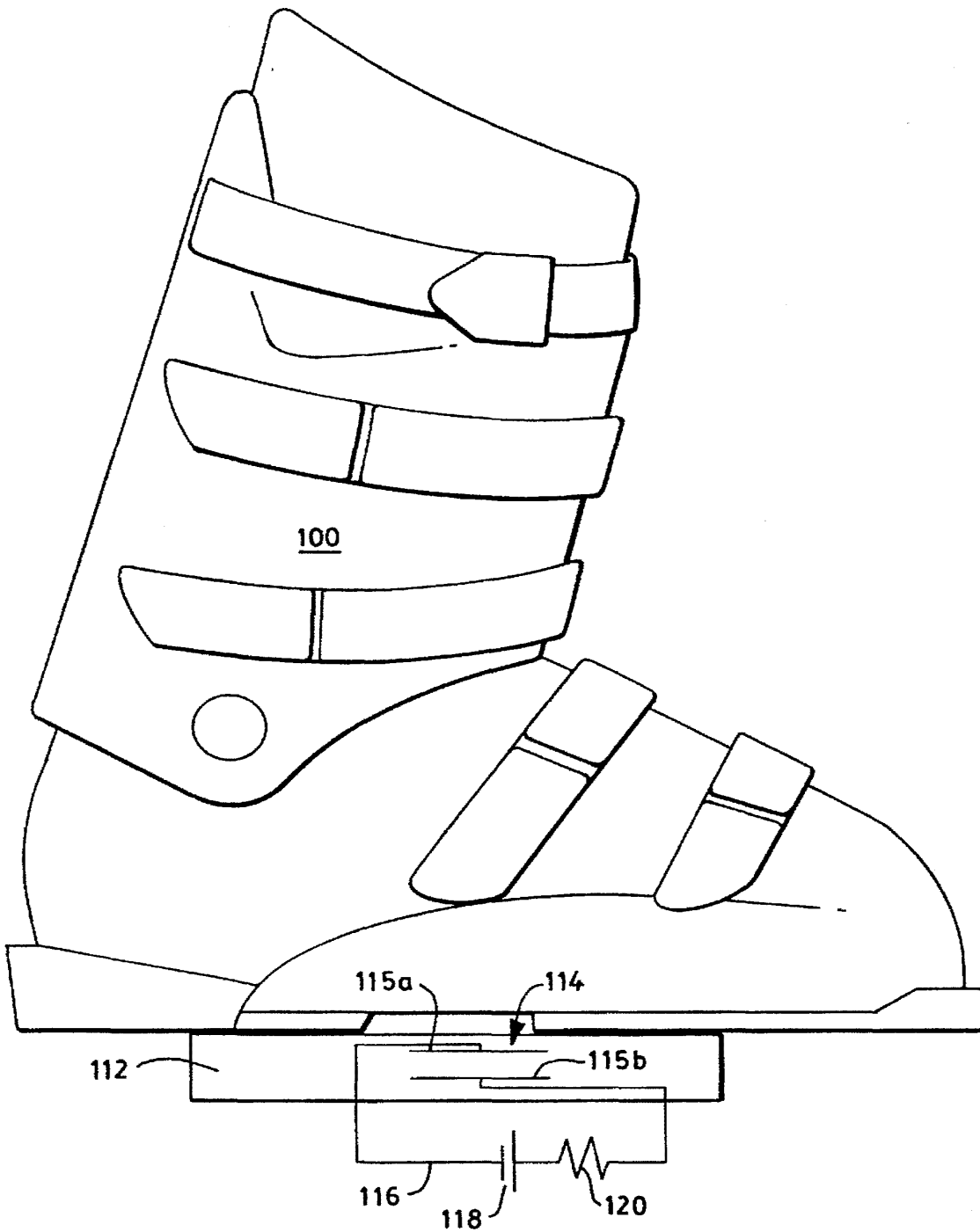

FIG. 7

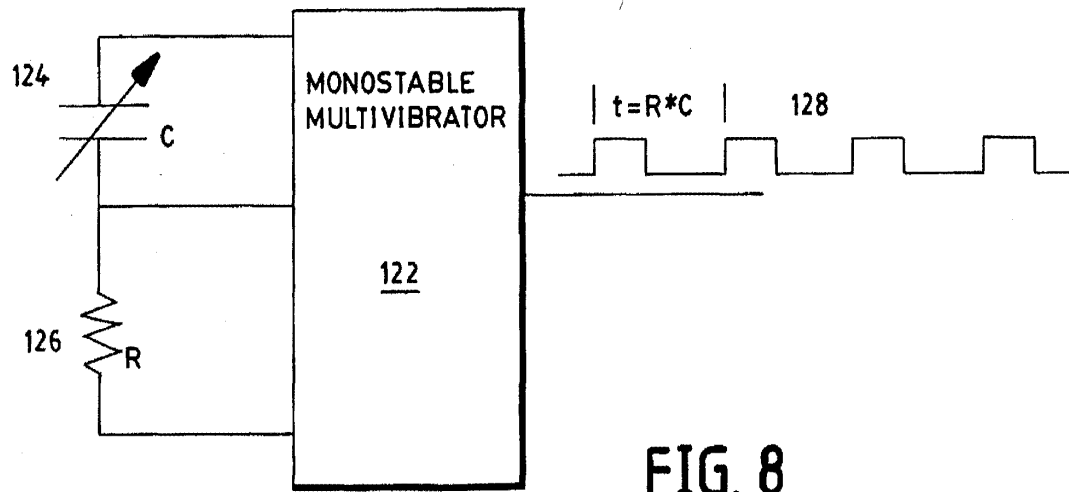

FIG. 8

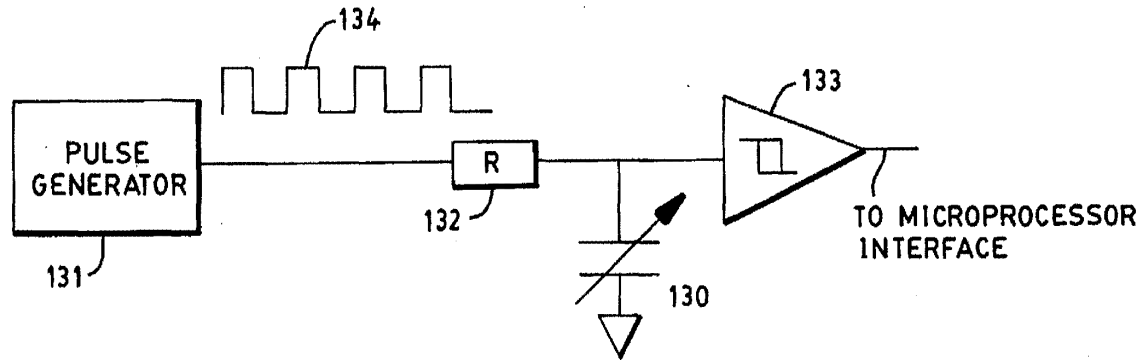

FIG. 9

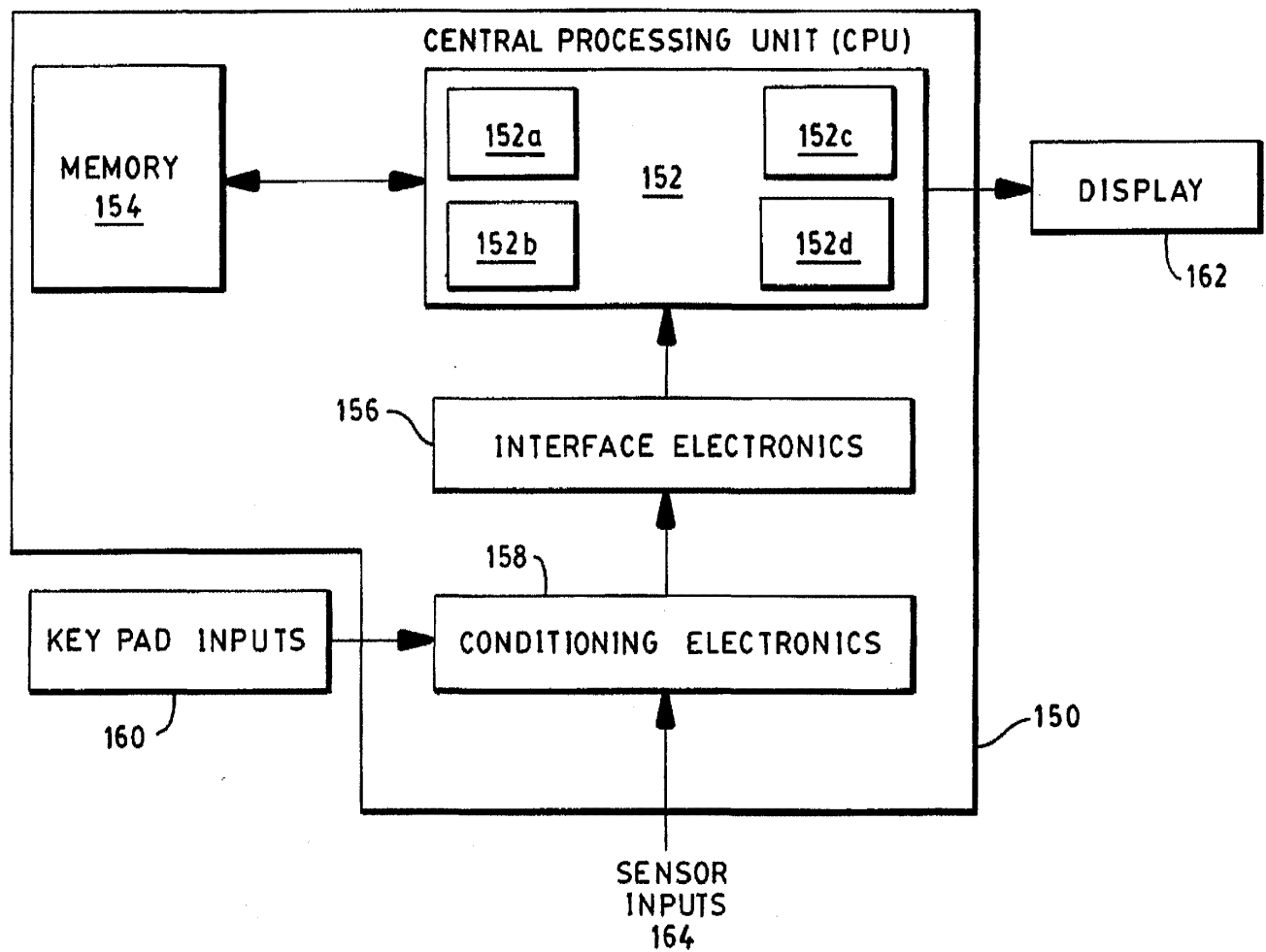

FIG. 10

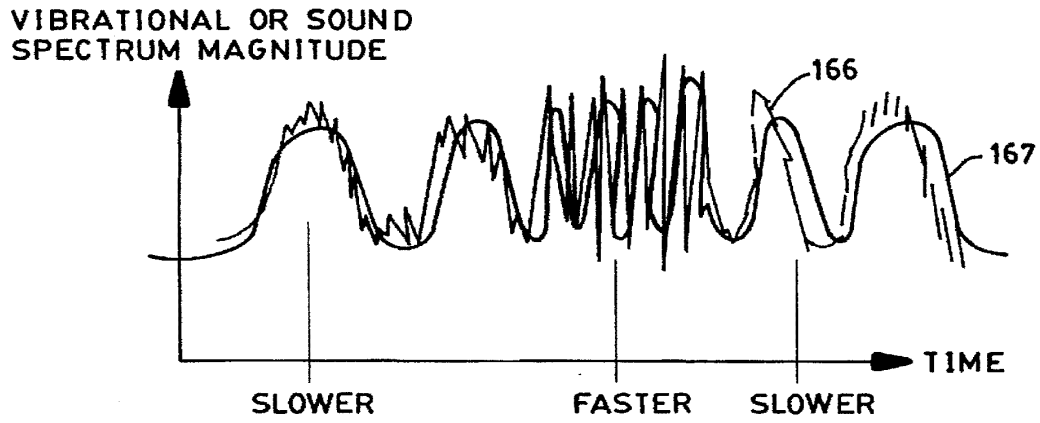

FIG. 11

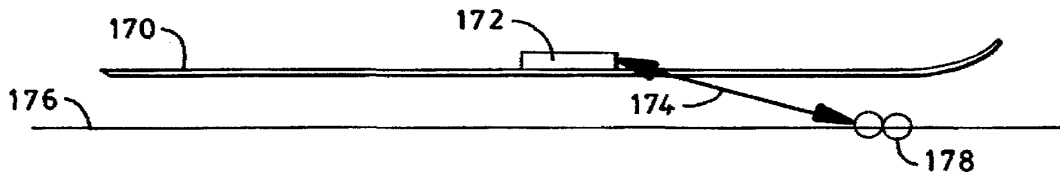

FIG. 12

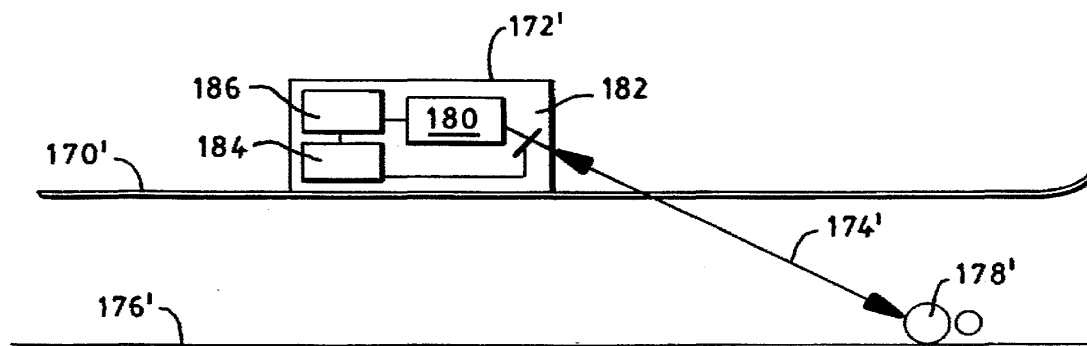

FIG. 12A

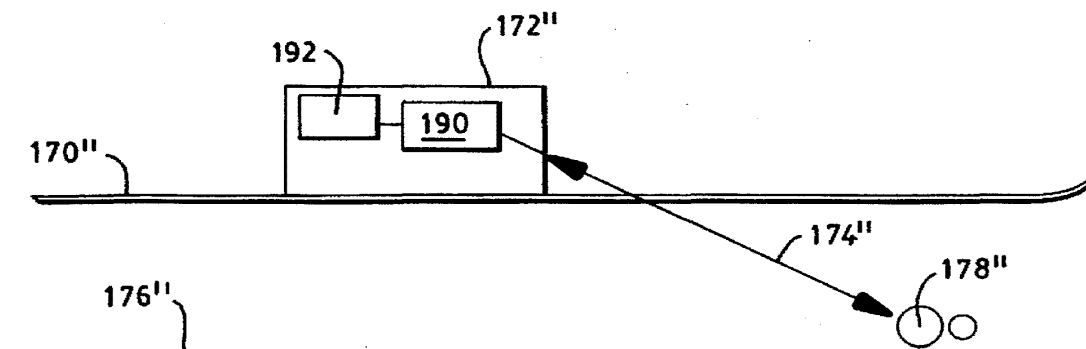

FIG. 12B

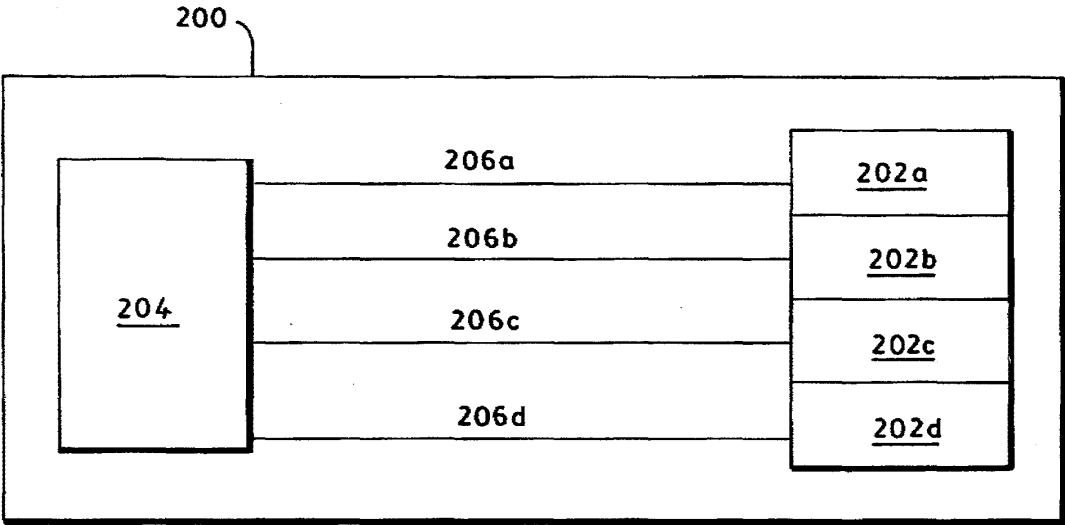

FIG. 13

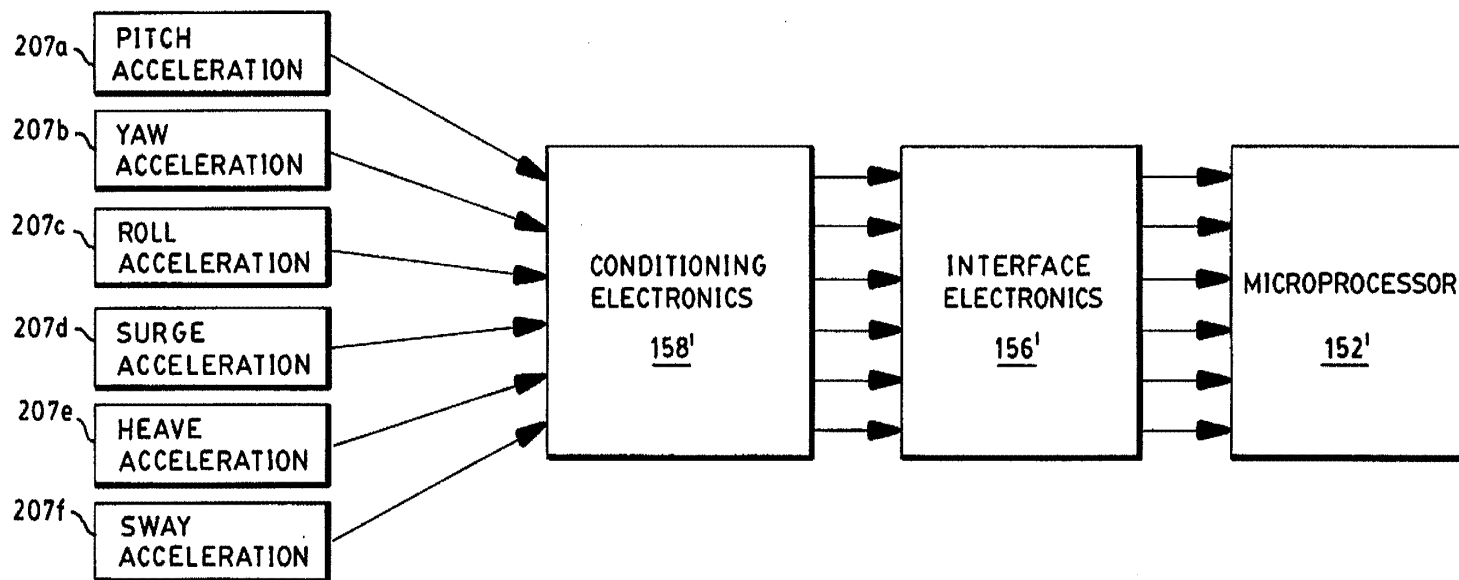

FIG. 14

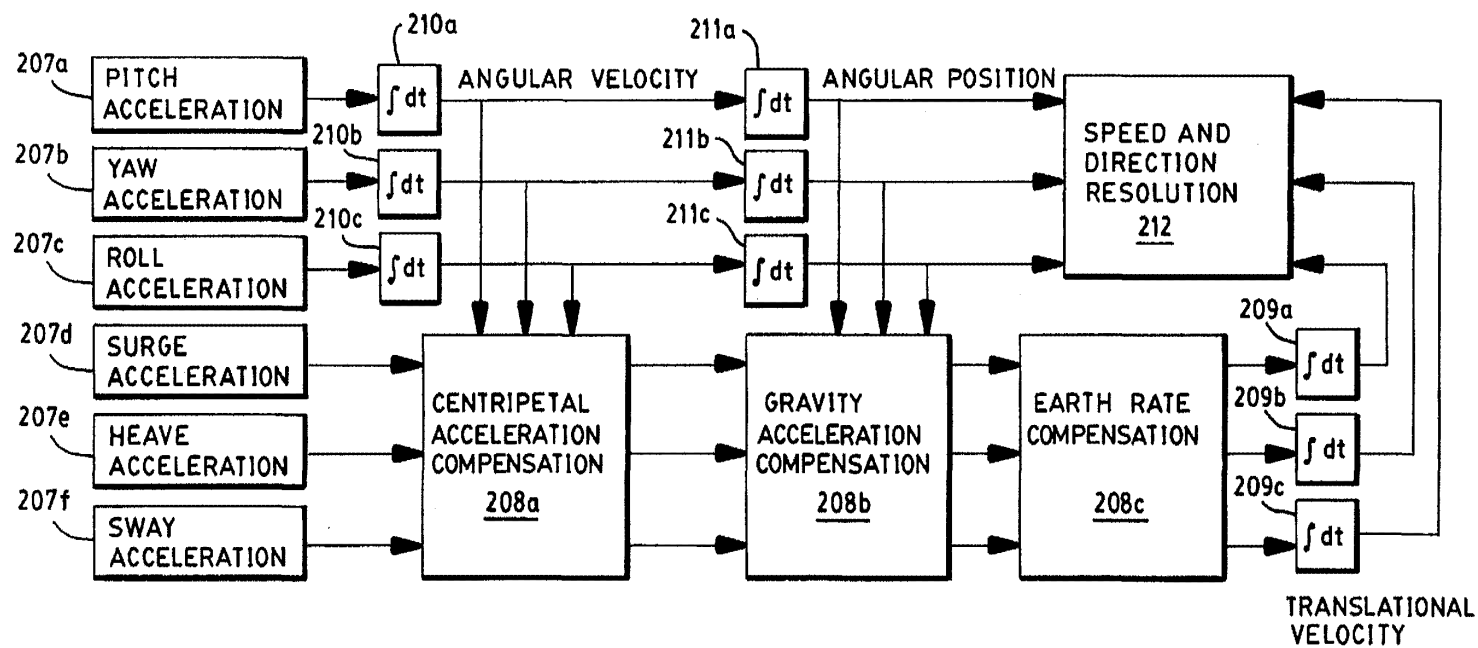

FIG. 14A

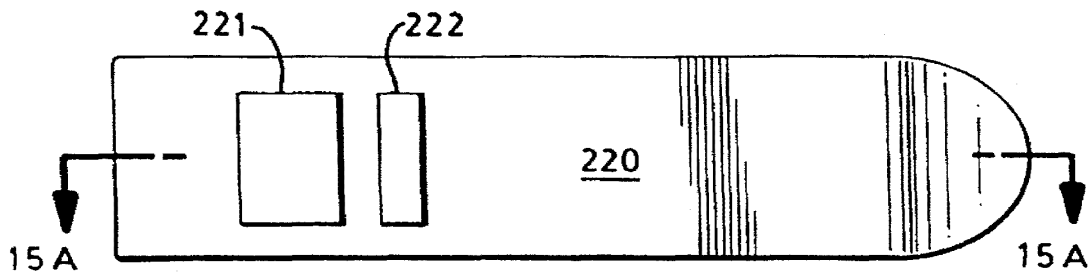

FIG. 15

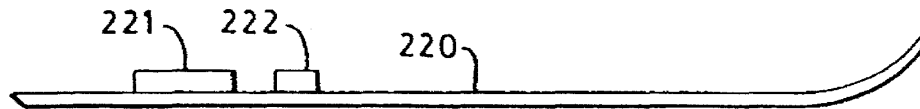

FIG. 15A

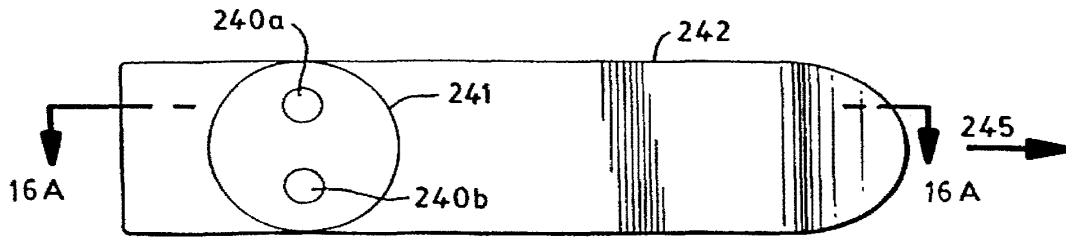

FIG. 16

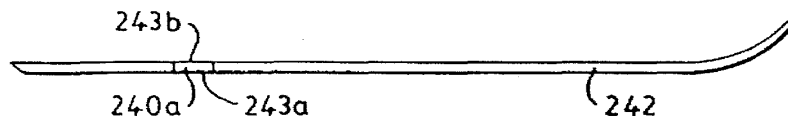

FIG. 16A

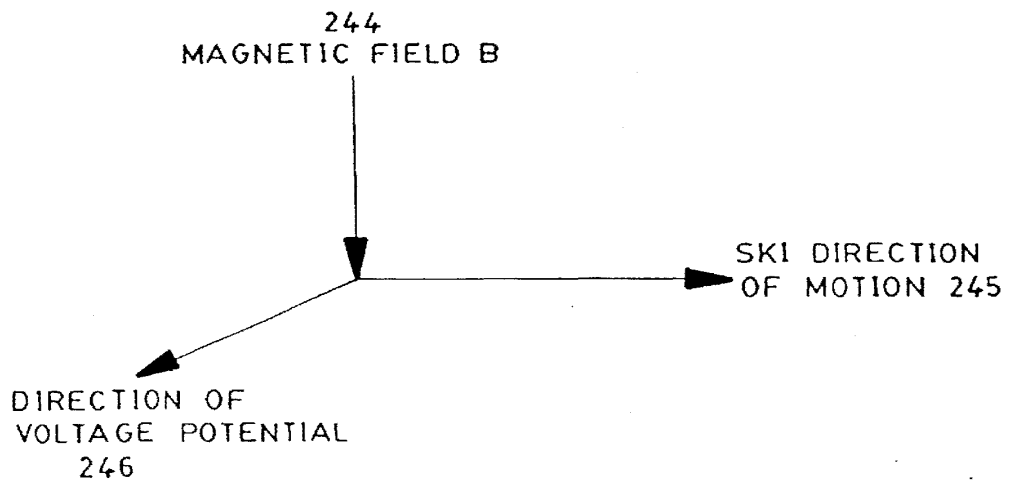

FIG. 16B

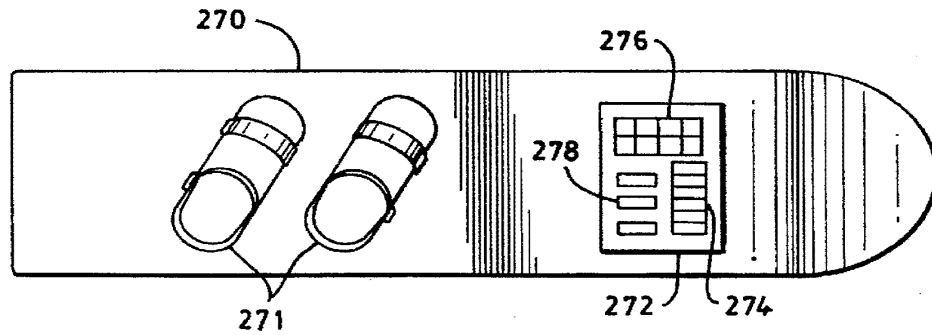

FIG. 17

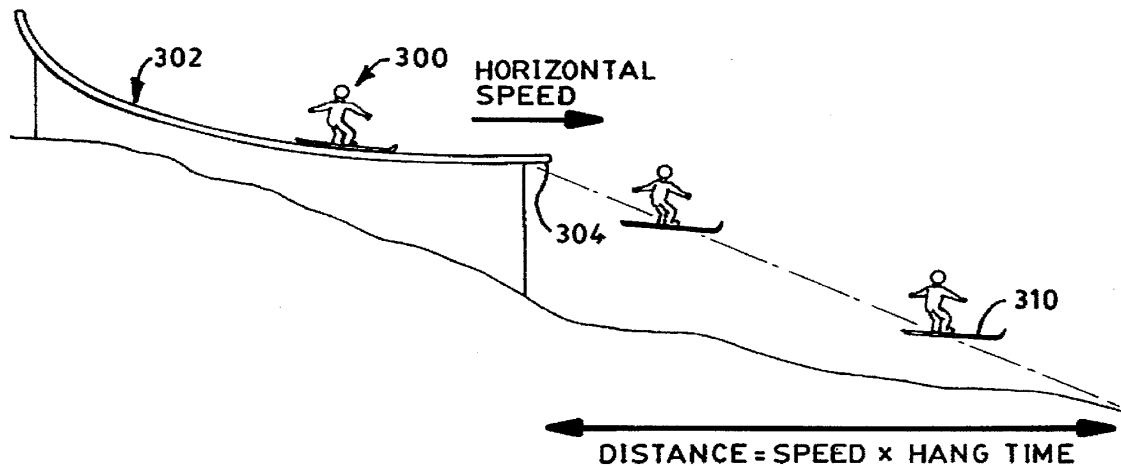

FIG. 18

1

APPARATUS AND METHODS FOR DETERMINING LOFT TIME AND SPEED

FIELD OF THE INVENTION

The invention relates generally to the measurement of the loft time and speed of a vehicle relative to the ground. Such measurements are particularly useful in sporting activities like skiing and mountain biking where users desire information relating to their speed and/or loft, or "air" time.

BACKGROUND OF THE INVENTION

It is well known that many skiers enjoy high speeds and jumping motions while traveling down the slope. High speeds refer to the greater and greater velocities which skiers attempt in navigating the slope successfully (and sometimes unsuccessfully). The jumping motions, on the other hand, include movements which loft the skier into the air. Generally, the greater the skier's speed, the higher the skier's loft into the air.

The interest in high speed skiing is apparent simply by observing the velocity of skiers descending the mountain. The interest in the loft motion is less apparent; although it is known that certain enthusiastic skiers regularly exclaim "let's catch some air" and other assorted remarks when referring to the amount and altitude of the lofting motion.

The sensations of speed and jumping are also readily achieved in other sporting activities, such as in mountain biking. Many mountain bikers, like the aforementioned skiers, also crave greater speeds and "air" time.

However, persons in such sporting activities typically only have a qualitative sense as to speed and loft or "air" time. For example, a typical snowboarding person might regularly exclaim after a jump that she "caught" some "big sky," "big air" or "phat air" without ever quantitatively knowing how much time really elapsed in the air.

It is, accordingly, an object of the invention to provide apparatus and methods for determining the "air" time of participants in sporting activities such as skiing and mountain biking.

It is another object of the invention to provide apparatus and methods for determining the speed of participants in sporting activities such as skiing and mountain biking.

It is yet another object of the invention to provide improvements to sporting devices which are ridden by sporting participants, and which provide a determination of speed and/or loft time of the device.

These and other objects of the invention will become apparent in the description which follows.

SUMMARY OF THE INVENTION

The invention concerns the detection and display of loft, or "air" time and/or speed of vehicles such as sporting vehicles, including skis, bikes, and snowboards. The invention thus provides a visual and quantitative measure of how much "air" time and, in certain aspects, how fast a user moves in a particular activity.

The invention provides, in one aspect, apparatus for determining the loft time of a moving vehicle off of a surface. A loft sensor senses a first condition that is indicative of the vehicle leaving the surface, and further senses a second condition indicative of the vehicle returning to the surface. A microprocessor subsystem, e.g., a microcontroller, determines a loft time that is based upon the first and second conditions, and the loft time is thereafter

2

displayed to a user of the apparatus by a display, e.g., a LCD or LED display. Preferably, a power module such as a battery is included in the apparatus to power the several components. In addition, a housing preferably connects and protects the microprocessor subsystem and the user interface; and further such that the housing is attachable to the vehicle.

According to another aspect, the invention includes memory for storing information representative of at least one of the following: (i) the first and second conditions, (ii) the loft time, (iii) a speed of the vehicle, (iv) successive records of loft time, (v) an average loft time, (vi) a total loft time, (vii) a dead time, (viii) a real activity time, and (ix) a numerical ranking of successive records.

One preferred aspect of the invention includes a speed sensor, connected to the microprocessor subsystem, which senses a third condition that is indicative of a velocity of the vehicle. In this aspect, the microprocessor subsystem includes means for converting the third condition to information representative of a speed of the vehicle. Accordingly, the apparatus provides a user with both loft time, e.g., "air" time, and a speed of the vehicle.

In yet another aspect, the display of the invention can display selective information, including one or more of the following: the loft time; a speed of the vehicle; a peak loft time; an average loft time; a total loft time; a dead time; a real activity time; an average speed; an indication that loft time is being displayed; an indication that speed is being displayed; an indication that dead time is being displayed; an indication that real activity time is being displayed; successive records of loft information; successive records of speed information; a distance traveled by the vehicle; a height achieved by the vehicle off of the surface; and an indication of a number of a successive record relative to all successive records.

In still another aspect, the invention includes a user interface for providing external inputs to the apparatus, including one or more of the following: a start/stop button for selectively starting and stopping the acquisition of data by the apparatus; a display-operate button for activating the display means selectively; a speed/loft toggle button for alternatively commanding a display of loft time information and speed information of the vehicle; means for commanding a display of successive records of loft time information selectively; means for commanding a display of successive records of speed information selectively; means for commanding a display of information corresponding to average loft time; means for commanding a display of information corresponding to average speed; means for commanding a display of total loft time; means for commanding a display of dead time; means for commanding a display of distance traveled by the vehicle; means for commanding a display of height achieved by the vehicle off of the surface; and means for commanding a display of real activity time.

Preferably, the microprocessor subsystem of the invention includes a clock element, e.g., a 24-hour clock, for providing information convertible to an elapsed time. Accordingly, the subsystem can perform various calculations, e.g., dead time, on the data acquired by the apparatus for display to a user.

In another aspect, the loft sensor is constructed with one of the following technologies: (i) an accelerometer that senses a vibrational spectrum; (ii) a microphone assembly that senses a noise spectrum; (iii) a switch that is responsive to a weight of a user of the vehicle; (iv) a voltage-resistance sensor that generates a voltage indicative of a speed of the vehicle; and (v) a plurality of accelerometers connected for evaluating a speed of the vehicle.

In a preferred aspect, the loft sensor of the invention senses a spectrum of information, e.g., a vibrational or sound spectrum, and the microprocessor subsystem determines the first and second conditions relative to a change in the spectrum of information. Further, the microprocessor sub-

assembly interprets the change in the spectrum to determine the loft time.

For example, one aspect of a loft sensor according to the invention includes one or more accelerometers that generate a vibrational spectrum of the vehicle. In such an aspect, the first and second conditions correspond to a change in the vibrational spectrum. By way of another example, one loft sensor of the invention includes a microphone subassembly that generates a noise spectrum of the vehicle; and, in this aspect, the first and second conditions correspond to a change in the detected noise spectrum. Because these spectrums are influenced by the particular activity of a user, e.g., standing in a ski line, a microprocessor subsystem of the invention preferably includes means for assessing boundary conditions of the spectrum and for excluding certain conditions from the determination of loft time. Accordingly, if a skier is in a lift line, such conditions are effectively ignored. One boundary condition, therefore, according to an aspect of the invention, includes an elapsed time between the first condition and the second condition that is less than approximately 500 ms; such that events that are within this boundary condition are excluded from the determination of loft time. One other boundary condition, in another aspect, includes an elapsed time between the first condition and the second condition that is greater than approximately five seconds; such that events that are outside this boundary condition are excluded from the determination of loft time. Because these boundary conditions are important in the aspects of the invention which utilize a spectrum of information, the apparatus preferably utilizes a user interface for providing selective external inputs to the microprocessor subsystem and for adjusting the boundary conditions selectively.

In still another aspect of the invention, the microprocessor subassembly includes means for determining a pitch of the spectrum by determining a best-fit sine wave to a primary frequency of at least part of the spectrum and means for correlating the pitch to a vehicle speed. Accordingly, the invention can detect spectrum information and correlate that information to a speed of the vehicle. Typically, a higher pitch frequency corresponds to a higher vehicle speed and a lower pitch frequency corresponds to a lower vehicle speed. However, in another aspect, the selected pitch frequency can be calibrated relative to a selected vehicle and speed.

The invention also provides, in another aspect, means for storing information including look-up tables with pitch-to-speed conversions for a plurality of vehicles. This is useful because different vehicles have different associated noise and/or sound spectrums associated with the vehicle. Accordingly, the invention in this aspect includes memory for storing the respective calibration information of the different vehicles (typically in a look-up table format) so that a user can utilize the invention on different vehicles and still determine speed accurately. Specifically, a particular pitch is associated with a particular speed for a particular vehicle; and that association is selectively made by the user.

The vehicles which are preferably used, according to the invention, include (i) a snowboards, (ii) snow skis, (iii) water skis, (iv) skis for ski jumping, and (v) skis for ski flying. However, in certain aspects of the invention, a human vehicle can be used; although the processing power required to accurately process speed and/or loft information in this aspect is significantly increased.

In several aspects of the invention, the microprocessor subassembly includes one or more of the following: means for selectively starting and stopping the acquisition of data by the apparatus; means for responding to an external request to activate the display means; means for responding to an external request to alternatively display the loft time and a speed of the vehicle; means for calculating a speed of the vehicle; means for responding to an external request to display successive records of loft time information; means for responding to an external request to display successive records of speed information; means for determining an average speed; means for determining a total loft time; means for determining a dead time; means for responding to an external request to display information corresponding to an average loft time; means for responding to an external request to display information corresponding to an average speed; means for responding to an external request to display a total loft time; means for responding to an external request to display a dead time; means for responding to an external request to display a distance traveled by the vehicle; means for responding to an external request to display a height achieved by the vehicle off of the surface; and means for responding to an external request to display a real activity time.

The invention also provides certain improvements to sporting vehicles of the type ridden by a user on a surface (e.g., sporting vehicle such as (i) snowboards, (ii) snow skis, (iii) water skis, (iv) skis for ski jumping, and (v) skis for ski flying). The improvements include, in one aspect, a speed sensor having (i) a voltage-measuring circuit including a pair of conductors arranged to contact the surface so that the surface is part of the circuit, and (ii) an electromagnet for selectively generating a magnetic field on the circuit, wherein a voltage generated by the circuit is proportional to a speed of the vehicle. In such an aspect, the microprocessor subsystem determines a speed of the vehicle that is based upon the voltage, and that speed is displayed to a user.

The invention also provides certain methodologies. For example, in one aspect, the invention provides a method for determining the loft time of a moving vehicle off of a surface, comprising the steps of: (1) sensing the vehicle leaving the surface at a first time; (2) sensing the vehicle returning to the surface at a second time; (3) determining a loft time from the first and second times, and (4) displaying the loft time to a user of the apparatus.

The invention is next described further in connection with preferred embodiments, and it will be apparent that various additions, subtractions, and modifications can be made by those skilled in the art without departing from the scope of the invention

BRIEF DESCRIPTION OF THE DRAWINGS

A more complete understanding of the invention may be obtained by reference to the drawings, in which:

FIG. 1 illustrates a system constructed according to the invention for determining loft and speed of a sporting vehicle carrying the system;

FIGS. 2, 2A and 2B show illustrative uses for the system 10 shown in FIG. 1;

FIG. 3 illustrates a user interface and display suitable for use in the system of FIG. 1;

FIG. 4 is a representative vibrational spectrum, shown illustratively, for calculating "air" or loft time in accord with the invention;

FIG. 5 shows a microphone-based loft sensor constructed according to the invention and which is suitable for use in the system of FIG. 1;

5

FIG. 6 shows a switch-based loft sensor constructed according to the invention and which is suitable for use in the system of FIG. 1;

FIG. 7 shows a capacitance-based loft sensor constructed according to the invention and which is suitable for use in the system of FIG. 1;

FIG. 8 schematically illustrates electronics, constructed according to the invention, for converting a varying capacitance, e.g., the capacitance derived from the loft sensor of FIG. 7, to information suitable for calculating "air" time;

FIG. 9 schematically illustrates alternative electronics, constructed according to the invention, for converting a varying capacitance, e.g., the capacitance derived from the loft sensor of FIG. 7, to information suitable for calculating "air" time;

FIG. 10 schematically illustrates a microprocessor subsystem constructed according to the invention and which is suitable for use in the system of FIG. 1;

FIG. 11 illustrates one exemplary pitch-detection process, in accordance with the invention, which is used to determine the speed of a vehicle;

FIG. 12 illustrates a Doppler-based approach to sensing speed in accordance with the invention;

FIG. 12A shows a laser-based Doppler speed sensor constructed according to the invention;

FIG. 12B shows an ultrasonic-based Doppler speed sensor constructed according to the invention;

FIG. 13 illustrates an accelerometer-based speed sensor constructed according to the invention and which is suitable for use as both the speed and loft sensors of FIG. 1;

FIG. 14 schematically illustrates process methodology of converting a plurality of acceleration values to speed, in accord with the invention;

FIG. 14A schematically illustrates a process methodology of calculating speed, direction, and vehicle height, in accord with the invention, by utilizing the accelerometer-based sensors of the invention;

FIGS. 15 and 15A illustrate a pressure-based speed sensor constructed according to the invention;

FIGS. 16 and 16A illustrate a magnetic/voltage-based speed sensor constructed according to the invention;

FIG. 16B shows relative motions, magnetic field directions, and voltages associated with the sensor of FIGS. 16 and 16A;

FIG. 17 illustrates an improvement to a snowboard in accord with the invention; and

FIG. 18 illustrates one use of the invention for detecting speed, "air," and distance in the sport of ski flying (or ski jumping) in accord with the invention.

DETAILED DESCRIPTION OF ILLUSTRATED EMBODIMENTS

FIG. 1 illustrates a system 10 constructed according to the invention. A microprocessor subsystem 12 controls the system 10 and connects to a user interface 14, a display 16, speed sensor 18 and loft sensor 20. A power supply 22, e.g., a battery, provides power to the system 10 and connects to the components 12,14,16,18 and 20 via appropriate electrical interconnections (not shown). The microprocessor subsystem 12 includes memory 13 for storing data acquired by the system 10.

The system 10 is incorporated into a relatively small housing, shown by the outline 24. The housing 24 is

6

preferably arranged to protect the components 12,14,16,18 and 20 from the elements of nature - such as rain, snow, sand and dust, each of which is expected during the ordinary course of usage on a ski slope and/or mountain bike trail. In addition, the housing 24 is attachable to a vehicle, such as a ski or mountain bike, by means such as a glue or a mechanical mount, e.g., screws. Alternatively, the housing (and hence the system 10) is incorporated integrally with the vehicle, such as inside a ski, such that only the display 16 and user interface 14 are visible and accessible.

Briefly, the invention shown in FIG. 1 operates as follows. The housing 24 is attached or mounted to a sporting device, such as a ski or mountain bike, such that a user of the ski or mountain bike can access the system 10. During motion of the ski or mountain bike, the speed sensor 18 sends velocity information (over communication line 11a) to the microprocessor subsystem 12; while the loft sensor 20 sends loft or "air" time information (over communication line 11b) to the microprocessor subsystem 12. The speed information and loft time information are processed by the microprocessor subsystem 12 to quantify actual speed, e.g., in miles per hour, and actual loft time, e.g., in seconds. The actual speed and loft time are thereafter stored in internal memory 13 until, at least, the speed and time data are accessed by a user of the system 10. Upon access through the user interface 14 (communicating with the microprocessor subsystem 12 via communication line 11c), a user of the system 10 can command the display of the speed and loft time data (sent across communication line 11d) on the display 16 in order to evaluate his or her performance in the sporting activity.

In an alternative embodiment, the speed and loft information can be stored prior to processing by the microprocessor subsystem 12; and later post-processed for display on the display 16 when commanded by a user of the system 10. Such an embodiment may be useful to conserve energy and to perform calculations to quantify the speed and loft data in a "batch" mode, such as known to those skilled in the art.

The system 10 of FIG. 1 preferably includes both of the speed sensor 18 and loft sensor 20; although it is not necessary for both sensors to be present in accord with the invention. Rather, in certain embodiments of the invention, only the loft sensor 20 is present within the system 10; and in certain other embodiments of the invention, only the speed sensor 18 is present within the system 10. Accordingly, in these embodiments, only the loft data or speed data, respectively, are available to a user of the system because the sensor which measures the information is absent.

FIGS. 2, 2A and 2B show typical uses of the system 10 illustrated in FIG. 1. In particular, FIG. 2 shows the system 10 mounted onto a ski 26. As is normal, the ski 26 is mounted to a skier 28 (for illustrative purposes, the skier 28 is only partially illustrated), via a ski boot 30 and binding 30a, and generally descends down a ski slope 32 with a velocity 34. Accordingly, one use of the system 10 is to calculate the peak speed of the ski 26 (and hence the skier 28) over a selectable period of time, e.g., during the time of descent down the slope 32.

Another use of the system 10 of FIG. 1 is to calculate the loft, or "air" time of the ski 26 (and hence the user 28) during the descent down the slope 32. Consider, for example, FIG. 2A, which illustrates the positions of the ski 26' and skier 28' during a lofting maneuver on the slope 32'. The ski 26' and skier 28' speed down the slope 32' and launch into the air 36 at position "a," and later land at position "b" in accord with the well-known Newtonian laws of physics. The system 10

calculates and stores the total "air" time that the ski 26' (and hence the skier 28') experience between the positions "a" and "b" so that the skier 28' can access and assess the "air" time information.

FIG. 2B illustrates the system 10 mounted onto a mountain bike 38. FIG. 2B also shows the mountain bike 38 in various positions during movement along a mountain bike race course 40 (for illustrative purposes, the bike 38 is shown without a rider). At one location "c" on the race course 40, the bike 38 hits a dirt mound 42 and catapults into the air 44. The bike 38 thereafter lands at location "d." As above, the system 10 provides information to a rider of the bike 38 about the speed attained during the ride around the race course 40; as well as information about the "air" time between location "c" and "d."

USER INTERFACE and DISPLAY

With further reference to FIG. 1, the display 16 can be one of any assortment of displays known to those skilled in the art. For example, liquid crystal displays (LCDs) are preferred because of their low power draw (for example, LCDs utilized in digital watches and portable computers are appropriate for use with the invention). Other suitable displays can include an array of light emitting diodes (LEDs) arranged to display numbers.

FIG. 3 illustrates a user interface 50 and display 52 constructed according to the invention and which are suitable for use, respectively, as the interface 14 and display 16 of FIG. 1. Outline 54 illustrates the outline of a system constructed according to the invention, e.g., the housing outline 24 of the system 10 of FIG. 1. In order for a user of the system to access information within the system, user interface 50 includes control buttons. For example, with reference to FIG. 3, one embodiment of the user interface 50 includes a start/stop button 58, a display-operate button 60, and a speed/loft toggle button 62. These buttons operate as follows:

A user presses the start/stop button 58 at the start of activity—such as at the start of skiing down a slope or biking down a trail—and presses the button 58 at the completion of activity to cease the acquisition of data (as described in more detail below).

A user pressed the display-operate button 60 to activate the display 52 so that a user can view recorded information from the sporting activity on the display 52. Accordingly, the display 52 is normally OFF—and not drawing power from the associated power source (e.g., the power source 22 of FIG. 1) - and is turned ON only when a user activates the display-operate button 52. The ON and OFF display conditions are preferably obtained in one of two ways: in one embodiment of the invention, the display 52 automatically turns OFF after a preselected time through the control of the microprocessor subsystem 12 of FIG. 1; or, in an alternative embodiment, the display 52 remains activated until a user again presses the display-operate button 60.

A user presses the speed/loft toggle button 62 to sequentially command the display, respectively, of information about speed and loft time. For example, if the display 52 currently displays speed information, a user can instead command the display of loft time information by pressing the speed/loft toggle button 62 once. If, on the other hand, the display 52 currently displays loft information, a user can instead command the display of speed information by pressing the speed/loft toggle button 62 once. Preferably, one portion 64 of the

display denotes whether speed or loft information is being displayed. For example, as illustrated, a "L" letter denotes that loft information is being displayed. An "S" letter likewise denotes that speed information is being displayed. For illustrative purposes, the "air" time is also displayed in FIG. 3 as 2.46 seconds, which represents the "air" time of a typical ski jump.

It is important to note that one embodiment of the invention does not include the speed/loft toggle button 62 because, as noted earlier, certain embodiments of the invention do not include both the speed sensor and loft sensor. In such an embodiment, it is unnecessary to include a toggle button 62.

The display 52 of FIG. 3 also shows another feature of the invention, namely that a system constructed according to the invention preferably calculates and stores successive records relating to speed and loft information relative to a user's activity. For example, a skier may catch "air" time more than once during a given activity; and the system of the invention can store successive loft times for access by the user. Most often, the peak "air" time is displayed, by default. However, certain users wish to evaluate successive loft time information and, accordingly, the system 10 of FIG. 1 preferably determines and stores the successive information (described in greater detail below). A user can access the successive loft time information by toggling a combination of the buttons 58-62, such as known to those skilled in the art (e.g., a combination of holding one button down while pressing another button); or by including yet another button 66 on the user interface 50. A display portion 68 of the display 52 shows a number corresponding to the sequential information on display. For example, the illustrated "1" number means that the highest "air" time record is currently being displayed; while a number greater than one means that a loft time other than the highest loft time is being displayed. In addition, the highest number displayed within the portion 68 refers to the total number of "air" times for the selected activity period (thus for example a user can determine the total number of jumps achieved for a given day).

In still another embodiment of the invention, successive speed information can be displayed much the way successive "air" time information is stored and displayed, described above. To view the speed information, the speed/loft toggle button 62 is pressed once to display "S" in the display portion 64, and a user can toggle button 66 to view the successive speed records as denoted by the number in display portion 68. However, this information is not deemed very useful except under a very few circumstances—since a user generally moves with some velocity during a given activity—and thus, generally, the peak speed achieved during a given activity is normally displayed on the display 52 when commanded by the speed/loft toggle button 62.

In an alternative embodiment, a button 67 is used to alter the modes of the system so that other information such as average "air" time may be calculated and displayed by the invention. For example, FIG. 3 illustrates a display portion 69 that shows a letter "A," corresponding to information relating to averages. Thus, for a particular sporting activity, a user can press button 69 to display "air" time as a running average of all the successive "air" times (in such an embodiment, the display portion 68 is preferably OFF because the information displayed in portion 68 refers to successive peak information). To access the peak "air" time information, the button 67 is pressed once again, causing the microprocessor subsystem 12 to change the display information from integrated average values to peak values (accordingly, the display portion 69 preferably shows a "P"

to identify to the user that peak information is being displayed; and the display portion 68 is preferably ON in this "peak" mode to denote which successive record is being displayed). To access integrated information—e.g., the total "air" time for a given day - the button 67 is pressed once again, causing the microprocessor subsystem 12 to show the integrated "air" or speed information (depending on the toggle of the speed/loft toggle button 62). Integrated values are preferably displayed by indicating to the user a "T" (for total) in the display portion 69.

It should be clear to those skilled in the art that other buttons and/or combinations of buttons can be incorporated within the user interface 50 within the scope of the invention. The microprocessor subsystem 12 of FIG. 1 stores much information during the sporting activity and which can be converted to different forms, e.g., averages, peaks, and totals. In accord with the invention, different buttons and combinations of buttons can be used to access all of the available information. In addition, other information can be denoted, for example, within the display portion 69 to identify the different types of information available within the system.

For example, yet another form of information which may be of interest to sporting persons is the "dead" time, i.e., the time that the person is not skiing or biking during the day. For example, a person who hangs out in the bar during part of the afternoon will not have a high efficiency factor for actual ski time as compared to the available ski time. This efficiency information is available in accord with the invention because the microprocessor subsystem 12 of FIG. 1 preferably includes a clock element (readily known to those skilled in the art) for indicating processed time over a selectable period (the microprocessor subsystem 12 can in fact include a 24-hour clock element, much the way a digital wrist-watch includes 24-hour information). Accordingly, a user can start the system 10 of FIG. 1 at the beginning of the day by pressing the start/stop button 58, and stop the collection of data at the end of the day by again pressing the start/stop button 58. The microprocessor subsystem 12 keeps track of the elapsed time between the start and stop of the system (i.e., the selectable time period), thereby providing means for determining the user's "dead" time for the day. That is, the microprocessor subsystem 12 calculates "dead" time by intelligently calculating the total time lapse within which a vibrational noise spectrum (described in more detail below in connection with FIG. 4) is present within the selectable time period; and dividing that total time lapse by the selectable time period to obtain a ratio of the real activity time versus the user's dead time (for example, a ratio of 80% means that the sporting person skied for 80% of the day). Dead time information is thereafter easily determined by subtracting 80% from 100%, to get 20% dead time. The dead time information is shown, for example, by toggling the button 67 to a dead time mode, denoted as "D," in the display portion 69, and displaying the dead time as a percentage in the display 52. Alternatively, the real activity time is displayed as a percentage in the display 52 by toggling the button 69 until "R" shows up in the display portion 69.

LOFT SENSOR

With further reference to FIG. 1, the loft sensor 20 may be constructed by several known components. Preferably, the sensor 20 is either an accelerometer or a microphone assembly. Alternatively, the sensor 20 may be constructed as a mechanical switch that detects the presence and absence of weight onto the switch. Each of these alternatives is described below.

Loft Sensor: Accelerometer Embodiment

An accelerometer, well known to those skilled in the art, detects acceleration and provides a voltage output that is proportional to the detected acceleration. Accordingly, the accelerometer senses vibration—particularly the vibration of a vehicle such as a ski or mountain bike—moving along a surface, e.g., a ski slope or mountain bike trail. This voltage output provides an acceleration spectrum over time; and information about loft time can be ascertained by performing calculations on that spectrum. Specifically, the microprocessor subsystem 12 of FIG. 1 stores the spectrum into memory 13 and processes the spectrum information to determine "air" time.

FIG. 4 illustrates a graph 70 of a representative vibrational spectrum 72 that is stored into the microprocessor subsystem 12 (FIG. 1). The vertical axis 74 of the graph 70 represents voltage; while the horizontal axis 76 represents time. At the beginning of activity 77—such as when a user of a system constructed according to the invention presses the start/stop button 58 (see FIG. 3)—the loft sensor 20 of FIG. 1 begins acquiring data and transferring that data to the microprocessor subsystem 12 via communication lines 11b. This data appears highly erratic and random, corresponding to the randomness of the surface underneath the vehicle (e.g., ski or vehicle). At time "t1," the user of the system lofts into the air, such as illustrated as location "a" in FIG. 2A and as location "c" in FIG. 2B; and lands some time later at time "t2," such as illustrated as location "b" in FIG. 2A and as location "d" in FIG. 2B. The vibrational spectrum between t1 and t2 is comparatively smooth as compared to the spectrum outside this region because the user's sporting vehicle (e.g., the ski or mountain bike) is in the air and is not therefore subjected to the random vibrations of the road or ski slope. Accordingly, this relatively smooth spectrum between t1 and t2 can be readily discerned from the rest of the spectrum by the microprocessor subsystem 12 and evaluated for "air" time: specifically, "air" time is t2-t1.

FIG. 4 also shows that the spectrum stops at the end 78 of the sporting activity, such as when the user of the system again presses the start/stop button 58, FIG. 3.

In one embodiment of the invention, a user can simply start the system 10 of FIG. 1 at the beginning of the day, by toggling the start/stop button 58, and stop the system 10 at the end of the day, by again toggling the start/stop button 58. The issue here, however, is that there may be apparent "air" times between the starting and stopping of the system which is not, in fact, the "air" time of interest. For example, standing in line at a ski lift represents a period within which the spectrum 72 appears smooth, and might be mistaken for "air" time. Accordingly, the microprocessor subsystem 12 of the invention preferably includes process boundary conditions within which "air" time will be excluded. For example, one practical boundary condition is: if the spectrum between any given "t1" and "t2" time (FIG. 4) is greater than five seconds, then exclude that time from memory as actual "air" time. Thus, each time the skier stands in line, that smooth spectrum which is being processed by the system is ignored.

Another boundary condition, for example, concerns the type of skier using the system. Some skiers often make quick jump turns down the mountain. These would normally show up as mini "air" times. Thus, in accord with another aspect of the invention, another boundary condition is: if the spectrum between any given "t1" time and "t2" time (FIG. 4) is less than 500 ms, then exclude that time from memory as actual "air" time. Accordingly, each jump turn will not be included in the total "air" time for the day, as is expected by users of the system.

The invention preferably includes an adjustment mechanism to adjust these boundary conditions (e.g., the five seconds maximum and the 0.5 second minimum) so that such conditions can be adjusted and optimized to individual users. Accordingly, in one embodiment of the invention, certain of the buttons 58-67 of FIG. 3 can be used in combination to set the maximum and minimum boundary conditions. Alternatively, one or more additional buttons can be included within the user interface of FIG. 3 to provide the adjustment mechanism.

Another embodiment of the invention internally resets the start/stop button 58 when the system senses the lack of spectral information for a preselected period of time. Thus, after the preselected period, the system has an automatic time-out, resulting in the microprocessor subsystem 12 resetting itself as if the start/stop button 58 were pushed.

Accelerometers are commercially available and are relatively cheap items. They are also small, so that all of the components 12, 14, 16 and 20 may easily fit within a small, lightweight housing. Suitable accelerometers include those accelerometers shown and described in connection with FIGS. 13, 14 and 14A.

Loft Sensor: Microphone Embodiment

A microphone, also well known to those skilled in the art, detects sound waves and provides a voltage output that is responsive to the detected sound waves. Accordingly, a microphone, like the accelerometer, senses the vibration of a vehicle, such as a ski or mountain bike, moving along a surface, e.g., a ski slope or mountain bike trail. By way of analogy, consider putting one's ear flat onto a desk and running an object across the desk. As one can readily determine, the movement of the object on the desk is readily heard in the ear. Likewise, a microphone as the loft sensor 20 readily "hears" the vibrational movements of the vehicle on the surface. Therefore, like the aforementioned accelerometer, a vibrational spectrum such as shown in FIG. 4 is generated by the microphone loft sensor during a user's sporting activity. As above, the microprocessor subsystem 12 utilizes the spectrum to determine "air" time.

Like accelerometers, microphones are also commercially available and are relatively cheap. They are also small, so that all of the components 12, 14, 16 and 20 may easily fit within a small, lightweight housing.

FIG. 5 illustrates one embodiment of a microphone assembly 80 suitable for use with the invention. Specifically, a system 82 constructed according to the invention mounts, for example, to a ski 84 (for illustrative purposes, only the loft sensor portion 80 and microprocessor subsystem 81 are shown as part of the system 82 even though other components such as the display and user interface are present within the system 82). The microphone assembly 80 preferably includes a tube portion 86 to funnel the sound waves 88 coming from the ski surface 90 to the microphone element 92, e.g., a piezoelectric element known to those skilled in the art. During operation, the vibrational motion caused by the ski's interaction with the surface underneath the ski generates the sound waves 88 detected by the element 92, which converts the sound waves to voltages. These voltages are sampled and stored in the microprocessor subsystem 12 so that the information can be processed to extract the "air" information.

Depending on the sensitivity of the accelerometers and microphone assemblies, described above, it is feasible to attach the system of the invention directly to a user of the system as opposed to the vehicle. The vibrational or sound

information is transmitted through the user to some degree while the user is on the ground, and such information can be used, as above, to calculate "air" time. Accordingly, one embodiment of the invention includes a system which measures "air" time that mounts directly to a user rather than to the vehicle, e.g., a ski.

Loft Sensor: Weight Switch Embodiment

In still another embodiment of the invention, the sensor 80 of FIG. 1 can be a switch that rests below the boot of the ski, e.g., the boot 30 of FIG. 2, and that senses pressure caused by the weight of the user within the boot. That is, when the skier is on the ground, the boot squeezes the switch, thereby closing the switch. The closed switch is detected by the microprocessor subsystem 12 (FIG. 1) as a discrete input. When a skier jumps into the air, the switch opens up by virtue of the fact that relatively no weight is on the switch; and this opened switch is also detected and input into microprocessor subsystem 12. The microprocessor subsystem 12 will count at known time intervals (clock rates) for the duration of the opened switch, corresponding to the jump, and will record how long the jump lasts.

As described in connection with FIG. 3, the "air" time may be recorded as a single jump, or recorded as a successive list of jumps. In addition, the "air" time can be summed or integrated into a running total, such as described above.

FIG. 6 illustrates the manner in which one switch is formed, in accord with the invention (for illustrative purposes, the drawing of FIG. 6, like most of the drawings herein, are not to scale; and further shows disproportionate sizes of elements of the invention at least). A boot 100 (e.g., the ski boot 30 of FIG. 2) rests on top of a compressible material 102, e.g., foam, that includes a switch 104. When the user steps on the compressible material 102, the compressible material 102 compresses and causes the switch 104 to close, completing the circuit 106 (for illustrative purposes, the circuit 106 is shown simply as a switch 104, battery 108 and resistor 110; and the circuit 106 is shown externally when in fact the circuit is within the system of the invention and in communication with the microprocessor subsystem 12). When the switch 104 is closed, the circuit is in an ON condition, and when the switch 104 is not closed, the system is in an OFF condition. Accordingly, the microprocessor subsystem 12 senses the ON and OFF conditions to calculate "air" time. Specifically, the time between an OFF condition and an ON condition can be used to determine "air" time.

Another embodiment of the invention which is suitable for use as the loft sensor 20, FIG. 1, includes a pad that is placed under the skier's boot and that changes capacitance as a function of a change of applied pressure. For example, consider FIG. 7 (again with illustrative ski boot 100) which shows a compressible material 112 and a capacitance-changing element 114 that changes capacitance under varying applied pressures. This capacitance-changing element 112 is connected in circuit 116, including the illustrative battery element 118 and resistor 120, with the system of the invention such that its capacitance is converted to a digital signal by conditioning electronics, such as shown in FIG. 8. As above, the circuit of FIG. 7 is shown illustratively and without the other necessary components (e.g., the microprocessor subsystem) of the invention. Those skilled in the art understand that the components 112, 114, 115, 116, 118 and 120 connect integrally with a system (e.g., the system 10 of FIG. 1) constructed according to the invention.

By way of background, a capacitor consists of two parallel plates separated by a dielectric material. The capaci-

13

tance is directly proportional to the cross sectional area of the plates and inversely proportional to the distance between the plates. When the dielectric is the compressible material 112, FIG. 7, then the pressure applied to the material 112 changes the distance between the plates 115a, 115b of the capacitance-changing element 114, thereby proportionately increasing the capacitance.

FIG. 8 shows a monostable multivibrator 122, e.g., a NE555, in accord with the invention which converts the varying capacitance (illustrated as portion 124) from the capacitance-changing element 114 of FIG. 7 to information suitable for calculating "air" time. A resistor 126 connects in circuit with the portion 124 and the multivibrator 122. The output pulse train 128 is directly dependent on the product of the resistance "R" and variable capacitance "C".

The resistance R may be fixed while the capacitance C is dependent on the pressure exerted on the pad 112 thus shifting the frequency of a pulse train 128. The pulse train 128 repetition rate is indicative of the value of capacitance of 124. When the pulse train 128 repetition rate increases the value of C 124 has decreased and the skier's boot is applying less pressure on the pad 112. This event marks the beginning of the "air time" measurement. When the pulse train 128 repetition rate decreases, meaning a sudden increase of capacitance, the boot is now applying greater pressure on the ski, signifying the end of the "air" time measurement. The length of time that the pulse train 128 remains at the higher repetition rate is equal to the amount of time the ski is off the ground. That amount of time is the loft or "air" time.

Alternatively, and such as shown in FIG. 9, the change in capacitance can be used in a filter which passes a pulse train during low capacitance levels (no boot pressure) and which filters out the pulse train during high capacitance events (high boot pressure). For example, a capacitance-changing element 130 (e.g., the capacitance-changing circuit 116 of FIG. 7) connects to the input of a Schmidt Trigger CMOS gate 133 and ground. A pulse generator 131 connects through a fixed resistor R 132 to the capacitance-changing element 133 and the Schmidt Trigger CMOS gate 133. The pulse generator 131 produces a steady pulse train 134. When the capacitance changing element 130 is at a high capacitance, corresponding to a high boot pressure meaning that the ski is on the ground, the combination of the fixed resistance R 132 and the capacitance of the capacitance-changing element 130 absorbs the pulse train and the output of the Schmidt Trigger CMOS gate 133 is constant. On the other hand, when the skier takes flight, the capacitance of the capacitance-changing element 130 is low, thus allowing the pulse train 134 to pass through to the Schmidt Trigger CMOS gate 133 input. The output of the Schmidt Trigger CMOS gate 133 in this latter case toggles at the same rate as the pulse train 131, thereby identifying a condition of "air" time. A discrete input is thus used by the processor to sample for the existence of the pulse train to calculate "air" time.

MICROPROCESSOR SUBSYSTEM

The microprocessor subsystem 10 of FIG. 1 can include a microcontroller element, a microcontroller element with reduced functionality to conserve power, or a microprocessor element with associated memory and logic to perform the requisite calculations of the invention, including the processing power to drive the display 16 and user interface 14. Preferably, however, the microprocessor subsystem 12 is constructed by several known components, such as shown in FIG. 10. FIG. 10 shows microprocessor subsystem 150

14

constructed according to the invention and including a Central Processing Unit (CPU) 152, memory 154, interface electronics 156, and conditioning electronics 158. The user interface 160, such as the interface 14 of FIG. 1, and including the button inputs of FIG. 3, connects to the subsystem such as shown and directly to the conditioning electronics 158. The display 162, such as the display 16 of FIG. 1, preferably connects to the subsystem such as shown and directly to the CPU 152.

The CPU 152 includes a microprocessor 152a, Read Only Memory (ROM) 152b (used to store instructions that the processor may fetch in executing its program), Random Access Memory (RAM) 152c (used by the processor to store temporary information such as return addresses for subroutines and variables and constant values defined in a processor program), and a master clock 152d. The microprocessor 152a is controlled by the master dock 152d that provides a master timing signal used to sequence the microprocessor 152a through its internal states in its execution of each processed instruction. The clock 152d is the master time source through which time may be deduced in measuring velocity or air time (for example, to determine the elapsed time from one event to another, such as the lapsed time "t1" to "t2" of FIG. 4, the clock rate provides a direct measure of time lapse).

The microprocessor subsystem 150, and especially the CPU 152, are preferably low power devices, such as CMOS; as is the necessary logic used to implement the processor design.

The subsystem 150 stores information about the user's activity in memory. This memory may be external to the CPU 152, such as shown as memory 154, but preferably resides in the RAM 152c. The memory may be nonvolatile such as battery backed RAM or Electrically Erasable Programmable Read Only Memory (EEPROM). External signals 164 from the speed and/or loft sensors, e.g., the speed sensor 18 and loft sensor 20 of FIG. 1, are connected to the conditioning electronics 158 which filters, scales, and, in some cases, senses the presence of certain conditions, such as zero crossings. This conditioning essentially cleans the signal up for processing by the CPU 152 and in some cases preprocesses the information. These signals are then passed to the interface electronics 156, which converts the analog voltage or currents to binary ones and zeroes understood by the CPU 152.

The invention also provides for intelligence in the signal processing, such as achieved by the CPU 152 in evaluating historical data. For example, "air" time may be determined by the noise spectra that changes abruptly, such as indicating a leap, instead of a noise spectra representing a more gradual change that would occur for example when a skier slows to a stop. As previously noted, a minimum quiet time is required, in certain embodiments of the invention, to differentiate between "air" time and the natural motions associated with turning and skiing (e.g., jump skiing). Further, in other certain embodiments, a maximum time is also programmed to differentiate "air" time from an abrupt stop, such as standing in a lift line.

SPEED SENSOR

In accord with the invention, if speed is calculated within the system, the speed sensor 118 of FIG. 1 can take one of several forms, including: (1) a pitch detection system that detects the "pitch" of the vibrational spectrum and that converts the pitch to an equivalent speed; (2) a laser-based or sound-based Doppler-shift sensor; (3) an accelerometer-

based speed sensor; (4) a pressure-based speed sensor; and (5) a voltage-resistance sensor

It should be noted that in either of the speed or loft sensors, it may be preferable to incorporate state machine logic within the sensor in order to preprocess the data for the microprocessor subsystem. Thus, in accord with the invention, processing logic such as described herein in connection with the microprocessor subsystem can be incorporated, at least in part, within one or both of the speed and loft sensors. Because of the complexity of the speed sensor, such preprocessing power is more appropriately within the speed sensor.

Speed Sensor: Pitch Detection

In accord with this embodiment, no separate speed sensor element, e.g., the sensor 18 of FIG. 1, is required. Rather, the vibrational spectrum that is generated by the loft sensor 20, and particularly the accelerometer or microphone embodiment discussed in connection with FIG. 4, will be used to determine the pitch of the vibration and, thereby, the equivalent speed. By way of example, note that a skier generates a scraping sound on hard-packed snow and ice. When the skier changes velocity, that scraping sound changes in pitch. The spectrum shown in FIG. 4 outside the t1/t2 region (but within the "start" and "end" region) is, effectively, that pitch. By calibrating the microprocessor subsystem 12 to associate one pitch as one velocity, and so on, the speed of the vehicle (e.g., ski and mountain bike) may be determined by spectral content.

In accord with the invention, one method for determining the "pitch" of the spectrum outside the t1/t2 loft region of FIG. 4 (and within the start/stop time) is to determine the "best fit" sine wave to the vibrational spectrum data. This sine wave will have a frequency, or "pitch" that may be quantified and used to correlate velocity.

This spectral content may be determined, in part, by the conditioning electronics 158 of FIG. 10 such to determining rise times to infer a bandwidth of the information. The conditioning electronics 158 and/or CPU 152 can also measure the time between successive zero crossings, which also determines spectral content.

For example, FIG. 11 illustrates a spectrum 166 generated from a sensor such as a sensor 18 or 20 (FIG. 1), or 82 (FIG. 5), or 202a-202d (FIG. 13 below). The spectrum 166 thus represents an acceleration spectrum or sound spectrum such as described herein. The microprocessor subsystem 12 of FIG. 1 evaluates the spectrum 166 and generates a best-fit sine wave 167 to match the primary frequency of the spectrum 166 over time. FIG. 11 shows illustratively a situation where a vehicle, such as a ski, moves slowly at first, corresponding to a lower sine-wave frequency, then faster, corresponding to a higher frequency sine wave, and then slower again. This pitch transition is interpreted by the microprocessor subsystem (e.g., the subsystem 12 of FIG. 1) as a change of speed. Specifically, the microprocessor subsystem of the invention is calibrated in this embodiment to associate a certain frequency with a certain speed; and speed is thus known for the variety of pitches observed during an activity, such as illustrated in FIG. 11.

It should be noted that the pitch information is surface dependent (and vehicle dependent). That is, a ski-over-snow-speed-spectrum has a different spectrum than a bicycle-over-ground-spectrum. Accordingly, different calibrations must be made for different vehicles and speeds, in accord with the invention. Further, certain spectrums may actually decrease in frequency as speed increases; which

also must be calibrated to obtain the correct speed information. These calibrations are typically programmed into the microprocessor subsystem memory, e.g., the memory 13 of subsystem 12 of FIG. 1. Further, in certain embodiments of the invention, the system stores different spectrum calibrations for different activities so that a user can move the system from one sport to another. Accordingly, one or more buttons such as the buttons 58-67 of FIG. 3 are introduced to the user interface, such as known to those skilled in the art, in order to selectively access the different spectrum calibrations.

Speed Sensor: Doppler-based

It is well known that Doppler radar is used by police vehicles to detect speed. In accord with this embodiment of the invention, the same principles apply to the measurement of speed of the sporting vehicle. For example, consider FIG. 12.

FIG. 12 shows a representative ski 170 (partially shown) with a Doppler-based sensor 172 mounted thereon (for illustrative purposes, the Doppler-based sensor is shown without the other elements of the system, such as the user interface and microprocessor). The sensor generates an electromagnetic beam 174, such as a laser beam, to bounce off the ground 176 (e.g., the ski slope) while the user of the system conducts the activity (e.g., skiing). The electromagnetic beam 174 is reflected off the ground by particles 178 which scatter at least a portion of the energy back to the sensor 172 along approximately the same path. Because the ski 170 is in motion, the returned energy is at a slightly different frequency from the outgoing frequency; hence the Doppler shift, which is a measurable quantity. Note that the sensor 172 must be arranged to generate a beam along the side (or in front or back of) the ski in order to "see" the ground 176.

The energy beam 174 is generated in one of two general ways: by a laser diode (to generate a laser beam) or by a piezoelectric transducer (to produce an ultrasonic beam). FIG. 12a, for example, shows a sensor 172' comprising a laser diode 180. The diode 180 generates a laser beam 174' which is reflected by the particles 178' back to the sensor 172'. A small beam-splitting mirror 182 reflects part of the returned beam to a detector 184 which is connected under the overall control of the microprocessor subsystem 186, e.g., the subsystem 12 of FIG. 1 (for illustrative purposes, the other elements of the system of the invention, e.g., the user interface, are not shown in FIG. 12a). The subsystem 186 evaluates the frequency difference between the outgoing beam from the diode 180 and the returned frequency from the detector 184. The frequency difference is readily converted to speed that is displayed on the display, e.g., the display 16 of FIG. 1.

Likewise, FIG. 12b shows a sensor 172" comprising a piezoelectric transducer 190 which generates an ultrasonic beam 174" that reflects from particles 178" back to the piezo transducer 190, which is connected under the overall control of the microprocessor subsystem 192, e.g., the subsystem 12 of FIG. 1 (for illustrative purposes, the other elements of the system of the invention, e.g., the user interface, are not shown in FIG. 12b). The microprocessor subsystem 192 generates a voltage at a set frequency to drive the piezoelectric transducer 190, to thereby generate the beam 174". The reflected Doppler-shifted beam returns through the transducer 190 (alternatively, through another piezo transducer (not shown)) and generates a voltage at the frequency of the reflected beam. The subsystem 192 evaluates the

frequency difference between the outgoing ultrasonic beam 174" and the returned frequency. As above, the frequency difference is readily converted to speed (via a conversion technique that is known to those skilled in the art) that is displayed on the display, e.g., the display 16 of FIG. 1.

Loft Sensor: Accelerometer Based

Modern navigation systems utilize a plurality of accelerometers to determine speed and direction. Particularly complex military systems, for example, utilize three translational and three rotational accelerometers to track direction and speed even during complex angular movements and at extremely high velocities. In accord with the invention, a similar plurality of accelerometers is used to determine speed. However, unlike military systems, one goal of the invention is to track speeds of sporting vehicles (e.g., a ski) that generally travel in one direction, namely forward. Therefore, the complexity of the accelerometer package is reduced since the orientation of the sensor may be fixed to the vehicle; and fewer than six accelerometers can be used to determine speed.

Accelerometers are well-known to those skilled in the art. They include, for example, translational and rotational accelerometers. FIG. 13 illustrates a speed sensor 200 constructed according to the invention and which includes a plurality of accelerometers 202a-202d. The accelerometers 202a-202d sense various accelerations in their respective axes (accelerometers sense acceleration along a predefined axis, translational or rotational), and each of the outputs from the accelerometers are input to the microprocessor subsystem 204, e.g., the subsystem 12 of FIG. 1, via communication lines 206a-206d. The orientation of the sensitive axis of each accelerometer 202a-202d is stored in the microprocessor subsystem 204 so that a particular acceleration in one axis is properly combined with acceleration values in other axes (as described in more detail below in connection with FIGS. 14 and 14a).

One key point that must be addressed with the accelerometer-based approach: gravity has a huge effect on the accelerometer signals; and gravity must be compensated for in order to achieve reasonable speed accuracy. Therefore, one or more of the accelerometers 202a-202d are used to determine and measure the force or gravity relative to the angle of the vehicle (e.g., the ski) so that gravity may be compensated for by the subsystem 204. Specifically, when the sensor 200 is pointed either downhill or uphill, gravity tends to reduce or increase the measured acceleration output; and that reduction or increase must be adjusted for or else the conversion from acceleration to speed (i.e., the integral of acceleration over time) will be next to useless. Accordingly, the orientations of the accelerometers 202a-202d relative to their respective sensitive axes must be known by the subsystem 204 in order to compensate for the acceleration of gravity, which is generally perpendicular to the motion of the vehicle, but which has a component acceleration in the direction of movement when the vehicle is pointed downwards or upwards.

It should be clear to those skilled in the art that fewer, or greater, numbers of accelerometers are within the scope of the invention, so long as they collectively determine speed. In effect, the fewer number of accelerometers results in reduced accuracy; not reduced functionality. Rather, in an ideal situation, one accelerometer can be used to detect speed; which is the integral of the acceleration over time. Further, a double integration over the same period provides distance; and, therefore, the invention can also provide distance in at least one embodiment of the invention.

It should also be noted that any of the accelerometers 202a-202d of FIG. 13 can be used, in accord with the invention, as the loft sensor 20 of FIG. 1 and without a separate component to measure "air" time. This is because each of the accelerometers 202a-202d generate a spectrum such as described in connection with FIG. 4. Accordingly, one or more of the accelerometers 202a-202d can be used to determine "air" time, described above, without the need for a separate loft sensor.

FIG. 14 schematically illustrates process methodology, according to the invention, which converts a plurality of acceleration inputs to speed. For example, when a plurality of six accelerometers (e.g., similar to the accelerometers 202a-202d of FIG. 13) are connected to a microprocessor subsystem such as the subsystem 150 of FIG. 10, the process methodology of the invention is preferably shown in FIG. 14. Specifically, six accelerometers are connected with various sensitive orientations to collect pitch 207a yaw 207b, roll 207c, surge 207d, heave 207e, and sway 207f accelerations. These accelerations are conditioned by the conditioning electronics 158' through the interface electronics 156' and CPU 152' to calculate speed, such as known to those skilled in the art of navigational engineering (for example, *Gyroscopic Theory, Design, and Instrumentation* by Wrigley et al., MIT Press (1969); *Handbook of Measurement and Control* by Herceg et al, Schaevitz Engineering, Pensauker, NJ, Library of Congress 76-24971 (1976); and *Inertial Navigation Systems* by Broxmeyer, McGraw-Hill (1964) describe such calculations and are hereby incorporated herein by reference). The elements 158', 156' and 152' are similar in construction to the elements 158, 156 and 152 described in connection with FIG. 10.

FIG. 14A schematically illustrates further process methodologies according to the invention wherein the six acceleration inputs 207a-207f are processed by the microprocessor subsystem of the invention (e.g., subsystem 12 of FIG. 1) such that centripetal, gravitational, and earth rate compensations are performed so that the various accelerations are properly integrated and compensated to derive speed (and even direction and distance). Specifically, a microprocessor subsystem of the FIG. 14A embodiment includes a centripetal acceleration compensation section 208a which compensates for motions of centripetal accelerations via inputs of surge 207d, heave 207e, and sway 207f. A gravity acceleration compensation section 208b in the subsystem further processes these inputs 207d-207f to compensate for the acceleration of gravity, while a earth rate compensation section 208c thereafter compensates for the accelerations induced by the earth's rotation (e.g., the earth rate acceleration at the equator is approximately opposite in direction to the force of gravity).

Also shown in FIG. 14A are translational integrators 209a-209c which convert the compensated accelerations from inputs 207d-207f to translational velocities by integration. Integrators 210a-210c likewise integrate inputs of pitch 207ayaw 207b, and roll 207c to angular velocity while integrators 211a-211c provide a further integration to convert the angular velocities to angular position. The angular positional information and translational velocity information is combined and processed at the speed and direction resolution section 212 to derive speed and direction. Preferably, the subsystem with the components 208, 209, 210, 211 and 212 is calibrated prior to use; and such calibration includes a calibration to true North (for a calibration of earth rate).

It should be noted that fewer of the inputs 207a-207f may be used in accord with the invention. For example, certain of

the inputs 207a-207f can be removed with the section 208a so that centripetal acceleration is not compensated for. This results in an error in the calculated speed and direction; but this error is probably small so the reduced functionality is worth the space saved by the removed elements. However, with the increased functionality of the several inputs 207a-207f, it is possible to calculate loft height in addition to speed because distance in three axes is known. Therefore, the invention further provides, in one embodiment, information for displaying height achieved during any given "air" time, as described above.

It should be apparent to those in the art that the accelerometers of FIG. 13-14 provide sufficiently detailed information such that the whole of the system according to the invention can be mounted to a user of the system directly, rather than directly to a vehicle. With the scope of the compensations described in connection with FIG. 14A, for example, movements of the human body, e.g., centripetal motions, may be compensated for to derive speed and/or loft time information that is uncorrupted by the user's movements. Such compensations, however, require powerful processing power.

Speed Sensor: Pressure Based

Pressure of the air is used in aviation to determine how high an aircraft is. The higher the altitude the lower the air pressure. Pressure sensors according to the invention convert air pressure to an analog voltage. When mounted to a snowboard 220, such as shown in FIGS. 15 and 15A, the pressure sensor 221 is used to determine the altitude of the snowboarder. This voltage is read by the microprocessor subsystem (e.g., the subsystem 12 of FIG. 1) at a fixed rate and differentiated to determine rate of descent or speed in the vertical direction. This may be converted to speed along the path by knowing the grade or angle of descent. Angle of descent is known by predetermining the geometry of the ski path or by the addition of an inclinometer 222 which gives a voltage dependent upon the angle, with respect to vertical, of the platform. The inclinometer 222 measures zero when the ski is traveling along a level path and the pressure sensor is showing a constant pressure. When the ski moves downhill, for example, the inclinometer 222 measures the angle of descent and the pressure sensor measures ever increasing pressure. Since the angle of descent is known, as is the rate of descent, the true speed is determined and displayed.

Those skilled in the art should understand that the elements 221 and 222 are connected in circuit with the further elements of the invention, e.g., the microprocessor subsystem 12 of FIG. 1; and that elements 221 and 222 are shown in FIG. 15 for illustrative purposes only when in fact they exist integrally with the system of the invention, e.g., the system 10 of FIG. 1.

Speed Sensor: Voltage-Resistance Based

Under-water vehicles and many oceanographic instruments measure water velocity by taking advantage of the principle discovered by Faraday that a conductor moving through a magnetic field produces a voltage across the conductor. The voltage produced is greatest when the conductor is orthogonal to the magnetic field and orthogonal to the direction of motion. This principal is used, in accord with the invention, to determine the speed that a skier moves over the snow in winter skiing or over the water in water skiing. As shown in FIGS. 16 and 16A, an electromagnet 241 is mounted to a snowboard 242. Two contacts 240a, 240b are mounted to the snowboard 242 such that the bottom 243a

makes contact with the snow and the top 243b of the contacts are connected to a voltage-measuring circuit within the conditioning electronics (such as the electronics 158 of FIG. 10 and such as known to those skilled in the art). When the snowboard 242 is flat on the snow, a conduction path is set up between the two contacts 240a, 240b and through the snow. When the electromagnet 241 is energized, a magnetic field 244 is imposed on the conduction path. As the snowboard 242 moves in the forward direction 245, the conduction path through the snow moves with the snowboard 242. This represents a moving conductor in a magnetic field; and as Faraday's theorem requires, a voltage 246 across the two terminals 240a, 240b will be generated that is proportional to the snowboarder's speed. This voltage 246 is read by the microprocessor subsystem (e.g., the subsystem 12 of FIG. 1). When the voltage abruptly goes to zero, and thereafter returns to a high voltage, the microprocessor subsystem determines that the gap in voltage is "air" time. Accordingly, in such an embodiment, no separate sensor 20 is required to measure "air" time (such as described above).

Those skilled in the art will appreciate that the elements of FIGS. 16-16B are shown illustratively for ease of understanding and without the further necessary elements of the invention, e.g., the microprocessor subsystem 12 of FIG. 1.

It should be clear to those skilled in the art that certain modifications can be made to the invention as described without departing from the scope of the invention. For example, vehicles other than skis and mountain bikes may be used with the invention. One vehicle, the snowboard, used in the ever popular snowboarding sport, is particularly well-suited for the invention (e.g., there is no jump skiing). The snowboard also has a wide body and a system constructed according to the invention can be incorporated within the body with the user interface, display, and associated buttons at the snowboard surface, for easy access. FIG. 17 shows such an improvement to a snowboard in accord with the invention. Specifically, a snowboard 270, with boot holder 271, incorporates a system 272 constructed according to the invention. The system 272, like the system 10 of FIG. 1, has a display 274, a user interface 276 that provides a user with buttons to selectively access speed and loft time, as described above, and one or more display portions 278 to display identification information about the displayed times (such as described in connection with FIG. 3).

FIG. 18 shows yet another use of the invention. Specifically, a further application of the invention is found in the sport of ski jumping and ski flying. Ski flying is similar to ski jumping except that ski jumping uses special, extralong skis, while ski flying uses standard alpine skis. The participant 300 skis down the long ramp 302, which may be as high as twenty-five stories, and launches horizontally into the air at the end 304 of the ramp 302. The objective of the sport is for the participant 300 to "jump" or "fly" through the air for as long as possible, and covering the greatest distance as possible. A system constructed according to the invention (not shown) is attached to the ski 310 to measure "air" time, speed, and distance, as described herein. In particular, the speed at the end 304 is used to predict distance by well-known Newtonian physics so that the participant's overall jump distance is calculated. This removes the necessity of having judges and/or other expensive equipment monitor the event, as the recorded "air" and jump distance is readily displayed by the system of the invention.

It is accordingly intended that all matter contained in the above description or shown in the accompanying drawings be interpreted as illustrative rather than in a limiting sense.

21

It is also intended that the following claims cover all of the generic and specific features of the invention as described herein, and all statements of the scope of the invention which, as a matter of language, might be said to fall there between.

Having described the invention, what is claimed as new and secured by Letters Patent is:

1. Apparatus for determining the loft time of a moving vehicle off of a surface, comprising:

a loft sensor for sensing a first condition that is indicative of the vehicle leaving the surface, and a second condition indicative of the vehicle returning to the surface, the loft sensor comprising one or more accelerometers for generating a vibrational spectrum of the vehicle, and wherein the first and second conditions correspond to a change in the vibrational spectrum;

a microprocessor subsystem for determining a loft time that is based upon the first and second conditions; and display means for displaying the loft time to a user of the apparatus.

2. Apparatus for determining the loft time of a moving vehicle off of a surface, comprising:

a loft sensor for sensing a first condition that is indicative of the vehicle leaving the surface, and a second condition indicative of the vehicle returning to the surface, the loft sensor comprising a microphone subassembly for generating a noise spectrum of the vehicle, and wherein the first and second conditions correspond to a change in the noise spectrum;

a microprocessor subsystem for determining a loft time that is based upon the first and second conditions; and display means for displaying the loft time to a user of the apparatus.

3. Apparatus according to claims 1 or 2, wherein the microprocessor subsystem further comprises means for assessing boundary conditions of the spectrum and for excluding certain conditions from the determination of loft time.

4. Apparatus according to claim 3, wherein the microprocessor subassembly further comprises (i) means for determining a pitch of the spectrum by determining a best-fit sine wave to a primary frequency of at least part of the spectrum, and (ii) means for correlating the pitch to a vehicle speed.

5. Apparatus according to claim 4, wherein the microprocessor subassembly further comprises means for correlating a higher pitch frequency with a higher vehicle speed and for correlating a lower pitch frequency with a lower vehicle speed.

6. Apparatus according to claim 4, further comprising means for calibrating the microprocessor subassembly wherein a selected pitch frequency corresponds to a selected vehicle speed.

7. Apparatus according to claim 4, further comprising (i) means for storing information including look-up tables with pitch-to-speed conversions for a plurality of vehicles, and (ii) means for selecting one of the vehicles, wherein a user selects the vehicle being used so that the apparatus correlates a particular pitch with a speed for the selected vehicle.

8. Apparatus according to claim 2, further comprising a tube portion that is connected to the vehicle for funneling sound waves to the microphone assembly.

9. Apparatus for determining the loft time of a moving vehicle off of a surface, comprising:

a loft sensor for sensing a first condition that is indicative of the vehicle leaving the surface, and a second condition indicative of the vehicle returning to the surface,

22

the loft sensor having a circuit that is responsive to a weight of a user of the vehicle, the circuit having a compressible material and a capacitance-changing element that changes in capacitance once the material is compressed;

a microprocessor subsystem for determining a loft time that is based upon the first and second conditions, the microprocessor sub system having means for detecting changes in the capacitance and for determining the loft time based upon the changes in capacitance; and display means for displaying the loft time to a user of the apparatus.

10. Apparatus for determining the loft time of a moving vehicle off of a surface, comprising:

a loft sensor for sensing a first condition that is indicative of the vehicle leaving the surface, and a second condition indicative of the vehicle returning to the surface; a microprocessor subsystem for determining a loft time that is based upon the first and second conditions;

a speed sensor comprising a plurality of accelerometers connected to the microprocessor sub system, each of the accelerometers sensing acceleration relative to a sensitive axis, the microprocessor sub system further comprising means for processing the plurality of acceleration signals to compensate for the forces of gravity and to determine a speed of the vehicle; and display means for displaying the loft time to a user of the apparatus.

11. Apparatus according to claim 10, wherein the microprocessor subsystem further comprises integration means for integrating the acceleration signals to determine distance traveled in at least one of the following axes: (i) in a forward axis that is substantially parallel to the movement by the vehicle along the surface, and (ii) in a height axis that is substantially perpendicular to movement by the vehicle along the surface.

12. Apparatus according to claim 10, wherein the microprocessor subsystem further comprises means for compensating for one or more of the following forces associated with the acceleration signals in order to determine speed more accurately: forces of centripetal acceleration; and forces of the earth's rotation.

13. Apparatus for determining the loft time of a moving vehicle off of a surface, comprising:

a loft sensor for sensing a first condition that is indicative of the vehicle leaving the surface, and a second condition indicative of the vehicle returning to the surface; a microprocessor subsystem for determining a loft time that is based upon the first and second conditions;

a speed sensor having (i) a pressure-to-voltage sensor for generating a voltage corresponding to an atmospheric pressure at the apparatus, and (ii) an inclinometer for determining an angle of orientation of the apparatus relative to horizontal, and wherein the microprocessor sub system comprises means for converting the voltage and angle to a rate of descent to determine a speed of the vehicle; and

display means for displaying the loft time to a user of the apparatus.

14. Apparatus for determining the loft time of a moving vehicle off of a surface, comprising:

a loft sensor for sensing a first condition that is indicative of the vehicle leaving the surface, and a second condition indicative of the vehicle returning to the surface; a microprocessor subsystem for determining a loft time that is based upon the first and second conditions;

23

a speed sensor connected in circuit with the microprocessor sub system and having (i) a voltage-measuring circuit having a pair of conductors arranged to contact the surface so that the surface is part of the circuit, and (ii) an electromagnet for selectively generating a magnetic field on the circuit, wherein a voltage generated by the circuit is proportional to a speed of the vehicle; and

display means for displaying the loft time to a user of the apparatus, the microprocessor sub system having means for converting the voltage to a speed for display on the display means.

15. In a sporting vehicle of the type ridden by a user on a surface, the sporting vehicle being selected from the group of (i) snowboards, (ii) snow skis, (iii) water skis, (iv) skis for ski jumping, and (v) skis for ski flying, the improvement comprising:

a speed sensor having (i) a voltage-measuring circuit including a pair of conductors arranged to contact the

24

surface so that the surface is part of the circuit, and (ii) an electromagnet for selectively generating a magnetic field on the circuit, wherein a voltage generated by the circuit is proportional to a speed of the vehicle;

a microprocessor subsystem for determining a speed of the vehicle that is based upon the voltage;

display means for displaying the speed to a user of the apparatus.

16. In a sporting vehicle of claim 15, the further improvement comprising a loft sensor for sensing a first condition that is indicative of the vehicle leaving the surface, and a second condition indicative of the vehicle returning to the surface, and wherein the microprocessor subsystem further comprises means for determining a loft time that is based upon the first and second conditions.

* * * * *

TRANSMITTAL FOR POWER OF ATTORNEY TO ONE OR MORE REGISTERED PRACTITIONERS			
NOTE: This form is to be submitted with the Power of Attorney by Applicant form (PTO/AIA/82B) to identify the application to which the Power of Attorney is directed, in accordance with 37 CFR 1.5, unless the application number and filing date are identified in the Power of Attorney by Applicant form. If neither form PTO/AIA/82A nor form PTO/AIA82B identifies the application to which the Power of Attorney is directed, the Power of Attorney will not be recognized in the application.			
Application Number	Not yet assigned		
Filing Date	April 4, 2014		
First Named Inventor	Theodore L Brann		
Title	TRAINING AND SAFETY DEVICE, SYSTEM AND METHOD TO AID IN PROPER MOVEMENT DURING PHYSICAL ACTIVITY		
Art Unit	Not Yet Assigned		
Examiner Name	Not Yet Assigned		
Attorney Docket Number	A209779		
SIGNATURE of Applicant or Patent Practitioner			
Signature	/William H. Mandir/	Date (Optional)	April 4, 2014
Name	William H. Mandir	Registration Number	32,156
Title (if Applicant is a juristic entity)			
Applicant Name (if Applicant is a juristic entity)			
NOTE: This form must be signed in accordance with 37 CFR 1.33. See 37 CFR 1.4(d) for signature requirements and certifications. If more than one applicant, use multiple forms.			
<input checked="" type="checkbox"/> *Total of <u>1</u> forms are submitted.			

STATEMENT UNDER 37 CFR 3.73(c)

Applicant/Patent Owner: LoganTree, LP

Application No./Patent No.: 6059576 Filed/Issue Date: May 9, 2000

Titled: TRAINING AND SAFETY DEVICE, SYSTEM AND METHOD TO AID IN PROPER MOVEMENT DURING PHYSICAL ACTIVITY

LoganTree, LP, a partnership

(Name of Assignee) (Type of Assignee, e.g., corporation, partnership, university, government agency, etc.) states that it is:

- 1. [x] the assignee of the entire right, title, and interest in;
2. [] an assignee of less than the entire right, title and interest in (The extent (by percentage) of its ownership interest is _____%); or
3. [] the assignee of an undivided interest in the entirety of (a complete assignment from one of the joint inventors was made)
the patent application/patent identified above by virtue of either:
A. [x] An assignment from the inventor(s) of the patent application/patent identified above. The assignment was recorded in the United States Patent and Trademark Office at Reel 013169, Frame 0942, or for which a copy therefore is attached.

OR

B. [] A chain of title from the inventor(s), of the patent application/patent identified above, to the current assignee as follows:

- 1. From: _____ To: _____
The document was recorded in the United States Patent and Trademark Office at Reel _____, Frame _____, or for which a copy thereof is attached.
2. From: _____ To: _____
The document was recorded in the United States Patent and Trademark Office at Reel _____, Frame _____, or for which a copy thereof is attached.
3. From: _____ To: _____
The document was recorded in the United States Patent and Trademark Office at Reel _____, Frame _____, or for which a copy thereof is attached.

[] Additional documents in the chain of title are listed on a supplemental sheet(s).

[] As required by 37 CFR 3.73(c), the documentary evidence of the chain of title from the original owner to the assignee was, or concurrently is being, submitted for recordation pursuant to 37 CFR 3.11.

[NOTE: A separate copy (i.e., a true copy of the original assignment document(s)) must be submitted to Assignment Division in accordance with 37 CFR Part 3, to record the assignment in the records of the USPTO. See MPEP 302.08]

The undersigned (whose title is supplied below) is authorized to act on behalf of the assignee.

/William H. Mandir/
Signature

April 4, 2014
Date

William H. Mandir
Printed or Typed Name

202.293.7060
Telephone Number

32,156
Reg No.

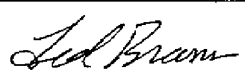
REEXAMINATION - PATENT OWNER POWER OF ATTORNEY OR REVOCATION OF POWER OF ATTORNEY WITH A NEW POWER OF ATTORNEY AND CHANGE OF CORRESPONDENCE ADDRESS	Control Number(s)	Not yet assigned	
	Filing Date(s)	April 4, 2014	
	First Named Inventor	Theodore L Brann	
	Title	TRAINING AND SAFETY DEVICE, SYSTEM AND METHOD TO AID IN PROPER MOVEMENT DURING PHYSICAL ACTIVITY	
	Patent Number	6,059,576	
	Examiner Name	Not yet assigned	
	Attorney Docket Number(s)	A209779	
<p>I hereby revoke all previous patent owner powers of attorney given in the above-identified reexamination proceeding control number(s).</p>			
<p>I hereby appoint</p> <p style="text-align: center;">Practitioners associated with Customer Number:</p> <p style="text-align: center;">WASHINGTON OFFICE 23373 CUSTOMER NUMBER</p> <p>as attorney(s) or agent(s) to prosecute the proceeding(s) identified above, and to transact all business on behalf of the undersigned in the United States Patent and Trademark Office (USPTO). In granting the foregoing powers, the undersigned recognizes that the specific practitioners associated with the Customer Number may be changed from time to time at the sole discretion of Sughrue Mion, PLLC.</p>			
<p>Please change the correspondence address for the above-identified reexamination proceeding control number(s) (more than one may be changed only if they are merged proceedings) to be:</p> <p style="text-align: center;">The address associated with the above-mentioned Customer Number.</p>			
<p>I am the:</p> <p><input type="checkbox"/> Inventor, having ownership of the patent being reexamined.</p> <p><input checked="" type="checkbox"/> Patent owner. <i>Statement under 37 CFR 3.73(b) (Form PTO/SB/96) submitted herewith.</i></p>			
<p>SIGNATURE of Inventor or Patent Owner</p>			
Signature		Date	April 3, 2014
Name	Theodore L. Brann	Telephone	210-347-5380
Title and Company	LoganTree LP's General Partner is Gulfstream Ventures, LLC, & Ted Brann is a Managing Member of Gulfstream Ventures, LLC		

Electronic Patent Application Fee Transmittal

Application Number:					
Filing Date:					
Title of Invention:	TRAINING AND SAFETY DEVICE, SYSTEM AND METHOD TO AID IN PROPER MOVEMENT DURING PHYSICAL ACTIVITY				
First Named Inventor/Applicant Name:	Theodore L. Brann				
Filer:	Quadeer A. Ahmed/Shanele Jones				
Attorney Docket Number:	A209779				
Filed as Large Entity					
ex parte reexam Filing Fees					
Description	Fee Code	Quantity	Amount	Sub-Total in USD(\$)	
Basic Filing:					
REQUEST FOR EX PARTE REEXAMINATION	1812	1	12000	12000	
Pages:					
Claims:					
Reexamination claims in excess of 20	1822	129	80	10320	
Miscellaneous-Filing:					
Petition:					
Patent-Appeals-and-Interference:					
Post-Allowance-and-Post-Issuance:					

Description	Fee Code	Quantity	Amount	Sub-Total in USD(\$)
Extension-of-Time:				
Miscellaneous:				
Total in USD (\$)				22320

Electronic Acknowledgement Receipt

EFS ID:	18674473
Application Number:	90013201
International Application Number:	
Confirmation Number:	9930
Title of Invention:	TRAINING AND SAFETY DEVICE, SYSTEM AND METHOD TO AID IN PROPER MOVEMENT DURING PHYSICAL ACTIVITY
First Named Inventor/Applicant Name:	Theodore L. Brann
Customer Number:	23373
Filer:	Quadeer A. Ahmed/Shanele Jones
Filer Authorized By:	Quadeer A. Ahmed
Attorney Docket Number:	A209779
Receipt Date:	04-APR-2014
Filing Date:	
Time Stamp:	12:36:22
Application Type:	Reexam (Patent Owner)

Payment information:

Submitted with Payment	yes
Payment Type	Credit Card
Payment was successfully received in RAM	\$22320
RAM confirmation Number	9392
Deposit Account	194880
Authorized User	SUGHRUE MION, PLLC

The Director of the USPTO is hereby authorized to charge indicated fees and credit any overpayment as follows:

Charge any Additional Fees required under 37 C.F.R. Section 1.16 (National application filing, search, and examination fees)

Charge any Additional Fees required under 37 C.F.R. Section 1.17 (Patent application and reexamination processing fees)

Charge any Additional Fees required under 37 C.F.R. Section 1.19 (Document supply fees)

Charge any Additional Fees required under 37 C.F.R. Section 1.21 (Miscellaneous fees and charges)

File Listing:

Document Number	Document Description	File Name	File Size(Bytes)/ Message Digest	Multi Part /.zip	Pages (if appl.)
1	Reexam Miscellaneous Incoming Letter	A209779REQUESTFOREXPARTEREEXAMINATIONTRANSMITTALFORMAsfiled.pdf	34174 e82e98ef6de0b6e7b13d8ac23d49f6f0056fbfc	no	2
Warnings:					
Information:					
2	Reexam Miscellaneous Incoming Letter	A209779REEXAMREQUESTUSP6059576BRANNASFILED.pdf	374674 91b29ab0ef0ba3ecbe5f7aa389f54b3be0b95d86	no	106
Warnings:					
Information:					
3	Copy of patent for which reexamination is requested	A209779CopyofpatenttoberexaminedUS6059576item6.pdf	1266480 95e6281955d6a1e97ba1e1d9ac7e8e0b912687	no	17
Warnings:					
Information:					
4	Information Disclosure Statement (IDS) Form (SB08)	A209779SB08RequestforReexasfiled.pdf	32432 0f75fc76f2da6571a40bf031e549eea9f6eba1e1	no	2
Warnings:					
Information:					
This is not an USPTO supplied IDS fillable form					
5	Foreign Reference	A209779REFVockUS6266623Item113.pdf	2522696 6aaa52b815d7198bdff075f6d8e60d75fa05e0a4d	no	41
Warnings:					
Information:					
6	Foreign Reference	A209779REFGaudetUS6018705Item112.pdf	1944250 4e6bde66db01d907bf1432a8aa85c8e51b565937	no	27
Warnings:					
Information:					
7	Foreign Reference	A209779REFFlentovUS5636146Item111.pdf	1968050 49b29fcc443e3dabc852e66d4c2b32d484acdef	no	29
Warnings:					
Information:					
8	Assignee showing of ownership per 37 CFR 3.73.	A209779PoATransmittaland373bStatementasfiled.pdf	28571 b23a89ce554b1dd19e7952da34ef5e38e526020f	no	2

Warnings:					
Information:					
9	Power of Attorney	A209779PoAExecuted.pdf	136088	no	1
			83d6edbc389f8a0c4ef350d793b76d832fd d2e51		
Warnings:					
Information:					
10	Fee Worksheet (SB06)	fee-info.pdf	31666	no	2
			46d24f9d1500073992acce6368d74c26b64 20a57		
Warnings:					
Information:					
Total Files Size (in bytes):			8339081		
<p>This Acknowledgement Receipt evidences receipt on the noted date by the USPTO of the indicated documents, characterized by the applicant, and including page counts, where applicable. It serves as evidence of receipt similar to a Post Card, as described in MPEP 503.</p> <p><u>New Applications Under 35 U.S.C. 111</u> If a new application is being filed and the application includes the necessary components for a filing date (see 37 CFR 1.53(b)-(d) and MPEP 506), a Filing Receipt (37 CFR 1.54) will be issued in due course and the date shown on this Acknowledgement Receipt will establish the filing date of the application.</p> <p><u>National Stage of an International Application under 35 U.S.C. 371</u> If a timely submission to enter the national stage of an international application is compliant with the conditions of 35 U.S.C. 371 and other applicable requirements a Form PCT/DO/EO/903 indicating acceptance of the application as a national stage submission under 35 U.S.C. 371 will be issued in addition to the Filing Receipt, in due course.</p> <p><u>New International Application Filed with the USPTO as a Receiving Office</u> If a new international application is being filed and the international application includes the necessary components for an international filing date (see PCT Article 11 and MPEP 1810), a Notification of the International Application Number and of the International Filing Date (Form PCT/RO/105) will be issued in due course, subject to prescriptions concerning national security, and the date shown on this Acknowledgement Receipt will establish the international filing date of the application.</p>					

REQUEST FOR *EX PARTE* REEXAMINATION TRANSMITTAL FORM

Address to:

Mail Stop *Ex Parte* Reexam

Commissioner for Patents

P.O. Box 1450

Alexandria, VA 22313-1450

Attorney Docket No.: A209779

Date: April 4, 2014

1. This is a request for *ex parte* reexamination pursuant to 37 CFR 1.510 of patent number 6059576 issued May 9, 2000. The request is made by:
 patent owner. third party requester.
2. The name and address of the person requesting reexamination is:
LoganTree LP
PO Box 2345
Boerne, TX 78006
3. Requester claims small entity (37 CFR 1.27) or micro entity status (37 CFR 1.29) - only a patent owner requester can claim micro entity status.
4. a. A check in the amount of \$_____ is enclosed to cover the reexamination fee, 37 CFR 1.20(c)(1);
 b. The Director is hereby authorized to charge the fee as set forth in 37 CFR 1.20(c)(1) to Deposit Account No. 19-4880;
 c. Payment by credit card. Form PTO-2038 is attached; or
 d. Payment made via EFS-Web.
5. Any refund should be made by check or credit to Deposit Account No. 19-4880. 37 CFR 1.26 (c). If payment is made by credit card, refund must be made to credit card account.
6. A copy of the patent to be reexamined having a double column format on one side of a separate paper is enclosed. 37 CFR 1.510(b)(4).
7. CD-ROM or CD-R in duplicate, Computer Program (Appendix) or large table
 Landscape Table on CD
8. Nucleotide and/or Amino Acid Sequence Submission
If applicable, items a. - c. are required.
 - a. Computer Readable Form (CRF)
 - b. Specification Sequence Listing on:
 - i. CD-ROM (2 copies) or CD-R (2 copies); or
 - ii. paper
 - c. Statements verifying identity of above copies
9. A copy of any disclaimer, certificate of correction or reexamination certificate issued in the patent is included.
10. Reexamination of claim(s) 1, 13, 20, and 21 is requested.
11. A copy of every patent or printed publication relied upon is submitted herewith including a listing thereof on Form PTO/SB/08, PTO-1449, or equivalent.
12. An English language translation of all necessary and pertinent non-English language patents and/or printed publications is included.

13. The attached detailed request includes at least the following items:
- a. A statement identifying each substantial new question of patentability based on prior patents and printed publications. 37 CFR 1.510(b)(1).
 - b. An identification of every claim for which reexamination is requested, and a detailed explanation of the pertinency and manner of applying the cited art to every claim for which reexamination is requested. 37 CFR 1.510(b)(2).
14. A proposed amendment is included (only where the patent owner is the requester). 37 CFR 1.510(e).
15. a. It is certified that a copy of this request (if filed by other than the patent owner) has been served in its entirety on the patent owner as provided in 37 CFR 1.33(c).
The name and address of the party served and the date of service are:
- _____
- _____
- Date of Service: _____ ; or
- b. A duplicate copy is enclosed since service on patent owner was not possible. An explanation of the efforts made to serve patent owner is **attached**. See MPEP § 2220.

16. Correspondence Address: Direct all communication about the reexamination to:

The address associated with Customer Number: _____ WASHINGTON OFFICE
23373
CUSTOMER NUMBER

OR

Firm or Individual Name _____

Address

City	State	Zip
Country		
Telephone	Email	

17. The patent is currently the subject of the following concurrent proceeding(s):
- a. Copending reissue Application No. _____
 - b. Copending reexamination Control No. _____
 - c. Copending Interference No. _____
 - d. Copending litigation styled: _____
- _____

WARNING: Information on this form may become public. Credit card information should not be included on this form. Provide credit card information and authorization on PTO-2038.

/William H. Mandir/	April 4, 2014
Authorized Signature	Date
William H. Mandir	32,156 <input checked="" type="checkbox"/> For Patent Owner Requester
Typed/Printed Name	Registration No. <input type="checkbox"/> For Third Party Requester

PATENT APPLICATION

IN THE UNITED STATES PATENT AND TRADEMARK OFFICE

In re application of	Docket No: A209779
Theodore L. Brann	Issued: May 9, 2000
U.S. Patent No. 6,059,576	Application No. 08/976,228
Filing Date: April 4, 2014	Group Art Unit: Not yet assigned
Confirmation No.: Not yet assigned	Examiner: Not yet assigned

For: TRAINING AND SAFETY DEVICE, SYSTEM AND METHOD TO AID IN PROPER MOVEMENT DURING PHYSICAL ACTIVITY

REQUEST FOR *EX PARTE* REEXAMINATION
OF U.S. PATENT NO. 6,059,576 BY PATENT OWNER

MAIL STOP EX PARTE REEXAMINATION
ATTN: CENTRAL REEXAMINATION UNIT
Commissioner for Patents
P.O. Box 1450
Alexandria, VA 22313-1450

Sir:

Ex parte reexamination under 35 U.S.C. §§ 302-307 and 37 C.F.R. 1.510 is hereby requested for claims 1, 13, 20, and 21 of United States Patent No. 6,059,576 which issued May 9, 2000 to Theodore L. Brann (hereinafter, the '576 Patent), directed to a Training and safety device, system, and method to aid in proper movement during physical activity. This patent has not expired. A copy of the '576 Patent is submitted herewith, in accordance with 37 C.F.R. § 1.510(b)(4).

Pursuant to 37 C.F.R. § 1.510, included with this request for ex parte reexamination (hereinafter, "Request") are:

- the fee for requesting *ex parte* reexamination;

Request for Ex Parte Reexamination by Patent Owner
U.S. Patent No. 6,059,576

- an identification of every claim for which reexamination is requested;
- a statement pointing out each substantial new question of patentability based on the cited patents and printed publications;
- a detailed explanation of how the cited patents and printed publications are applied to every claim for which reexamination is requested;
- a copy of every patent or printed publication relied upon or referred to in the Request, accompanied by an English language translation of all the necessary and pertinent parts of any non-English language patent or printed publication; and
- a copy of the entire patent to be reexamined, including the front face, drawings, and specification/claims (in double column format), and a copy of any disclaimer, certificate of correction, or reexamination certificate issued in the patent.

A Table of Contents follows for convenience.

TABLE OF CONTENTS

I.	LISTING OF CLAIMS1
II.	STATUS OF THE CLAIMS AND EXEMPLARY SUPPORT FOR CLAIM AMENDMENTS29
III.	IDENTIFICATION OF EVERY CLAIM FOR WHICH REEXAMINATION IS REQUESTED33
IV.	STATEMENT POINTING OUT EACH SUBSTANTIAL NEW QUESTION OF PATENTABILITY BASED ON CITED PATENTS AND PRINTED PUBLICATIONS34
	The '576 Patent and the claims being requested to be reexamined34
	Prosecution History34
	There is a substantial new question of patentability for claims 1, 13, 20 and 2140
	Flentov raises a substantial new question of patentability for independent claims 1, 13, and 2041
	Flentov raises a substantial new question of patentability for claim 2143
	Gaudet raises a substantial new question of patentability for independent claims 1, 13, and 2045
	Vock raises a substantial new question of patentability for independent claims 1, 13, and 2047
V.	DETAILED EXPLANATION OF HOW THE CITED PATENTS AND PRINTED PUBLICATIONS ARE APPLIED TO EVERY CLAIM FOR WHICH REEXAMINATION IS REQUESTED49
	Application of the art49
	Application of Flentov to claim 150
	Application of Flentov to claim 1354

Request for Ex Parte Reexamination by Patent Owner
U.S. Patent No. 6,059,576

Application of Flentov to claim 2059
Application of Flentov to claim 2162
Application of Gaudet to claim 164
Application of Gaudet to claim 1371
Application of Gaudet to claim 2079
Application of Vock to claim 184
Application of Vock to claim 1388
Application of Vock to claim 2095
VII. NEW CLAIMS99
VIII. CONCLUSION102

I. LISTING OF CLAIMS

1. (original): A portable, self-contained device for monitoring movement of body parts during physical activity, said device comprising:

a movement sensor capable of measuring data associated with unrestrained movement in any direction and generating signals indicative of said movement;

a power source;

a microprocessor connected to said movement sensor and to said power source, said microprocessor capable of receiving, interpreting, storing and responding to said movement data based on user-defined operational parameters;

at least one user input connected to said microprocessor for controlling the operation of said device;

a real-time clock connected to said microprocessor;

memory for storing said movement data; and

an output indicator connected to said microprocessor for signaling the occurrence of user-defined events;

wherein said movement sensor measures the angle and velocity of said movement.

2. (original): The device of claim 1 further comprising at least one input/output port connected to said microprocessor for downloading said data and uploading said operational parameters to and from a computer.

Request for Ex Parte Reexamination by Patent Owner
U.S. Patent No. 6,059,576

3. (original): The device of claim 1 wherein said device is compact and weighs less than one pound.

4. (original): The device of claim 1 wherein said movement sensor comprises at least one accelerometer.

5. (original): The device of claim 1 wherein said movement sensor can simultaneously detect real time movement along at least two orthogonal axes.

6. (original): The device of claim 1 wherein said movement sensor is housed separately from said microprocessor.

7. (original): The device of claim 1 wherein said monitored body part movement is torso or limb movement.

8. (original): The device of claim 1 wherein said data measured by said movement sensor includes the distance of said movement.

9. (original): The device of claim 1 wherein said output indicator is visual.

10. (original): The device of claim 1 wherein said output indicator is audible.

11. (original): The device of claim 1 wherein said output indicator is tactile.

12. (original): The device of claim 1 wherein said user input is a switch.

13. (original): A system to aid in training and safety during physical activity, said system comprising

a portable, self-contained movement measuring device, said movement measuring device further comprising

a movement sensor capable of measuring data associated with unrestrained movement in any direction and generating signals indicative of said movement;

a power source;

a microprocessor connected to said power source, said microprocessor capable of receiving, interpreting, storing and responding to said movement data based on user-defined operational parameters;

at least one user input connected to said microprocessor for controlling the operation of said device;

a real-time clock connected to said microprocessor;

memory for storing said movement data;

at least one input/output port connected to said microprocessor for downloading said data and uploading said operational parameters; and

an output indicator connected to said microprocessor;

a computer running a program capable of interpreting and reporting said movement data based on said operational parameters; and

a download device electronically connected to said movement measuring device and said computer for transmitting said movement data and operational parameters between said movement measuring device and said computer for analysis, reporting and operation purposes;

wherein said movement sensor measures the angle and velocity of said movement.

14. (original): The system of claim 13 wherein said computer is a personal computer.

15. (original): The system of claim 13 wherein said computer is connected to a network of other computers.

16. (original): The system of claim 13 wherein said download device is a physical docking station.

17. (original): The system of claim 13 wherein said download device is a wireless device.

18. (original): The system of claim 17 wherein said wireless device uses radio frequency.

19. (original): The system of claim 17 wherein said wireless device uses infrared light.

20. (original): A method to monitor physical movement of a body part comprising the steps of:

attaching a portable, self-contained movement measuring device to said body part for measuring unrestrained movement in any direction;

measuring data associated with said physical movement;

interpreting said physical movement data based on user-defined operational parameters and a real-time clock; and

storing said data in memory.

21. (original): The method of claim 20 wherein said physical movement data includes velocity data of said movement, angle measurement data taken along at least two orthogonal axes, and related date and time data.

22. (original): The method of claim 21 further comprising the step of defining said parameters for a specific physical movement prior to said interpreting step.

23. (original): The method of claim 21 further comprising the step of downloading said data from said movement measuring device to a computer for reporting and analysis purposes.

24. (original): The method of claim 21 wherein said interpreting step comprises teaching an individual how to properly perform said physical movement.

Request for Ex Parte Reexamination by Patent Owner
U.S. Patent No. 6,059,576

25. (original): The method of claim 20 wherein said movement measuring device is an accelerometer.

26. (original): The method of claim 20 further comprising the step of providing real time feedback regarding said movement.

27. (original): The method of claim 26 wherein said physical movement is physical labor.

28. (original): The method of claim 26 wherein said physical movement is an exercise related to medical treatment.

29. (original): The method of claim 26 wherein said physical movement is an exercise to improve technique related to an athletic skill.

30. (new): The device of claim 1, wherein said microprocessor stores, in said memory, at least one time stamp in association with said movement data.

31. (new): The device of claim 30, wherein said microprocessor stores, in said memory, a date associated with the at least one time stamp.

32. (new): The device of claim 30, wherein said microprocessor retrieves said at least one time stamp from said real-time clock and associates the retrieved time stamp with said received movement data.

33. (new): The device of claim 32, wherein said microprocessor retrieves said at least one time stamp from said real-time clock based on the occurrence of at least one of the user-defined events.

34. (new): The device of claim 33, wherein said microprocessor identifies the at least one of the user-defined events based on interpretation of the movement data.

35. (new): The device of claim 1, wherein said memory continues to store said movement data in response to battery power being lost from said power source.

36. (new): The device of claim 1, wherein said movement sensor continuously checks for said movement.

37. (new): The device of claim 36, wherein said microprocessor continuously interprets, based on the user-defined operational parameters, said movement data received from said movement sensor.

38. (new): The device of claim 1, wherein said output indicator displays information based on said movement data.

39. (new): The device of claim 38, wherein said output indicator displays said information based on said movement data and at least one time stamp associated with said movement data.

40. (new): The device of claim 30, wherein said output indicator displays information based on said movement data and the at least one time stamp associated with said movement data.

41. (new): The device of claim 1, wherein said output indicator displays, based on said movement data, information indicating that a threshold is met.

42. (new): The device of claim 41, wherein said threshold is based on information provided by the user.

43. (new): The device of claim 41, wherein said memory stores said information indicating that the threshold is met.

44. (new): The device of claim 43, wherein said memory stores a time stamp in association with said information indicating that the threshold is met.

45. (new): The device of claim 1, wherein said output indicator indicates a low battery condition of the device.

46. (new): The device of claim 9, wherein said output indicator is selected from the group consisting of single monochromatic LEDs, multiple colored lights, and liquid crystal displays.

47. (new): The device of claim 1, wherein said movement data stored in the memory is configured to be downloaded to a computer.

48. (new): The device of claim 47, further comprising:
software configured to communicate with external software, wherein the external software is configured to present the downloaded movement data to the user.

49. (new): The device of claim 48, wherein said external software is configured to run on the computer.

50. (new): The device of claim 49, wherein said downloaded movement data is analyzed by said user via said external software.

51. (new): The device of claim 48, wherein said external software is configured to interpret said movement data and produce at least one report.

52. (new): The device of claim 48, wherein said external software is configured to interpret said movement data and produce at least one history report.

53. (new): The device of claim 52, wherein said at least one history report includes dates and times of said movement data.

54. (new): The device of claim 48, wherein said external software is configured to allow the user to program additional reports and histories with respect to said movement data of said user.

55. (new): The device of claim 47, wherein said movement data is configured to be downloaded to said computer via a wired connection.

56. (new): The device of claim 47, wherein said movement data is configured to be downloaded to said computer via a wireless connection.

57. (new): The device of claim 1, wherein the microprocessor records, based on a threshold being met, the time and date of the threshold being met.

58. (new): The device of claim 57, wherein the output indicator provides a visual indicator to the user regarding the threshold being met.

59. (new): The device of claim 58, wherein said user sets the threshold.

60. (new): The device of claim 1, wherein the memory stores a plurality of thresholds respectively corresponding to a plurality of notifications.

61. (new): The device of claim 60, wherein when one of the plurality of thresholds is met, the output indicator displays a corresponding one of the notifications.

62. (new): The device claim 61, wherein the microprocessor determines whether any of the thresholds are met by interpreting the movement data with respect to the thresholds.

63. (new): The device of claim 60, wherein at least one of the plurality of thresholds is set by the user.

64. (new): The device of claim 60, wherein the plurality of thresholds are different from each other.

65. (new): The device of claim 60, wherein the plurality of notifications are different visual indicators.

66. (new): The device of claim 65, wherein at least one of the visual indicators including a blinking indicator.

67. (new): The device of claim 1, wherein said microprocessor interprets said movement data to determine whether a threshold is met, and said output indicator signals the occurrence of at least one of the user-defined events based on said microprocessor determining that the threshold is met.

68. (new): The device of claim 67, wherein said microprocessor interprets said movement data to determine whether the threshold is met by comparing said movement data to said threshold.

69. (new): The device of claim 1, wherein said device is configured to be placed on said user's arm to monitor and record said movement data.

70. (new): The device of claim 69, wherein said movement sensor measures movement of said user's arm.

71. (new): The device of claim 1, wherein said movement sensor measures a walking distance.

72. (new): The device of claim 71, wherein said device is configured to be wearable by the user, and said movement sensor measures said walking distance of said user.

73. (new): The device of claim 1, wherein said microprocessor stores, in said memory, (i) at least one time stamp in association with said movement data and (ii) a date associated with at the at least one time stamp,

wherein said movement sensor constantly checks for said movement,

wherein said output indicator displays, based on said movement data, information indicating that a threshold is met,

wherein said movement data stored in the memory is configured to be downloaded to a computer,

wherein the device further comprises software configured to communicate with external software configured to run on a computer and present the downloaded movement data,

wherein said external software is configured to produce at least one report based on said movement data,

wherein the memory stores a plurality of thresholds respectively corresponding to a plurality of notifications,

wherein said device is configured to be placed on said user's arm to monitor and record said movement data,

wherein said movement sensor measures movement of said user's arm.

74. (new): The system of claim 13, wherein said microprocessor stores, in said memory, at least one time stamp in association with said movement data..

75. (new): The system of claim 74, wherein said microprocessor stores, in said memory, a date associated with the at least one time stamp.

76. (new): The system of claim 74, wherein said microprocessor retrieves said at least one time stamp from said real-time clock and associates the retrieved time stamp with said received movement data.

77. (new): The system of claim 76, wherein the output indicator is configured to signal the occurrence of user-defined events, and said microprocessor retrieves said at least one time stamp from said real-time clock based on the occurrence of at least one of the user-defined events.

78. (new): The system of claim 77, wherein said microprocessor identifies the at least one of the user-defined events based on interpretation of the movement data.

79. (new): The system of claim 13, wherein said memory continues to store said movement data in response to battery power being lost from said power source.

80. (new): The system of claim 13, wherein said movement sensor constantly checks for said movement.

81. (new): The system of claim 80, wherein said microprocessor constantly interprets, based on the user-defined operational parameters, said movement data received from said movement sensor.

82. (new): The system of claim 13, wherein said output indicator displays information based on said movement data.

83. (new): The system of claim 82, wherein said output indicator displays said information based on said movement data and at least one time stamp associated with said movement data.

84. (new): The system of claim 74, wherein said output indicator displays information based on said movement data and the at least one time stamp associated with said movement data.

85. (new): The system of claim 13, wherein said output indicator displays, based on said movement data, information indicating that a threshold is met.

86. (new): The system of claim 85, wherein said threshold is based on information provided by the user.

87. (new): The system of claim 85, wherein said memory stores said information indicating that the threshold is met.

88. (new): The system of claim 87, wherein said memory stores a time stamp in association with said information indicating that the threshold is met.

89. (new): The system of claim 13, wherein said output indicator indicates a low battery condition of the device.

90. (new): The system of claim 13, wherein said output indicator is visual, and said output indicator is selected from the group consisting of single monochromatic LEDs, multiple colored lights, and liquid crystal displays.

91. (new): The system of claim 13, wherein said movement data stored in the memory is configured to be downloaded to the computer.

92. (new): The system of claim 91, wherein the portable, self-contained movement measuring device further comprises:

software configured to communicate with the program running on the computer, wherein the program is configured to present the downloaded movement data to the user.

93. (new): The system of claim 92, wherein said downloaded movement data is analyzed by said user via said program.

94. (new): The system of claim 92, wherein said program is configured to interpret said movement data and produce at least one report.

95. (new): The system of claim 92, wherein said program is configured to interpret said movement data and produce at least one history report.

96. (new): The system of claim 95, wherein said at least one history report includes dates and times of said movement data.

97. (new): The system of claim 92, wherein said program is configured to allow the user to program additional reports and histories with respect to said movement data of said user.

98. (new): The system of claim 91, wherein said movement data is configured to be downloaded to said computer, using the download device, via a wired connection.

99. (new): The system of claim 91, wherein said movement data is configured to be downloaded to said computer, using the download device, via a wireless connection.

100. (new): The system of claim 13, wherein the microprocessor records, based on a threshold being met, the time and date of the threshold being met.

101. (new): The system of claim 100, wherein said output indicator provides a visual indicator to the user regarding the threshold being met.

102. (new): The system of claim 101, wherein said user sets the threshold.

103. (new): The system of claim 13, wherein the memory stores a plurality of thresholds respectively corresponding to a plurality of notifications.

104. (new): The system of claim 103, wherein when one of the plurality of thresholds is met, the output indicator displays a corresponding one of the notifications.

105. (new): The system of claim 104, wherein the microprocessor determines whether any of the thresholds are met by interpreting the movement data with respect to the thresholds.

106. (new): The system of claim 103, wherein at least one of the plurality of thresholds is set by the user.

107. (new): The system of claim 103, wherein the plurality of thresholds are different from each other.

108. (new): The system of claim 103, wherein the plurality of notifications are different visual indicators.

109. (new): The system of claim 108, wherein at least one of the visual indicators includes a blinking indicator.

110. (new): The system of claim 13, wherein said output indicator is configured to signal the occurrence of user-defined events, said microprocessor interprets said movement data to determine whether a threshold is met and said output indicator signals the occurrence of at least one of the user-defined events based on said microprocessor determining the threshold is met.

111. (new): The system of claim 110, wherein said microprocessor interprets said movement data to determine whether the threshold is met by comparing said movement data to said threshold.

112. (new): The system of claim 13, wherein said device is configured to be placed on said user's arm to monitor and record said movement data.

113. (new): The system of claim 112, wherein said movement sensor measures movement of said user's arm.

114. (new): The system of claim 13, wherein said movement sensor measures a walking distance.

115. (new): The system of claim 113, wherein said device is configured to be wearable by the user, and said movement sensor measures said walking distance of said user.

116. (new): The system of claim 13, wherein said microprocessor stores, in said memory, (i) at least one time stamp in association with said movement data and (ii) a date associated with at the at least one time stamp,

wherein said movement sensor constantly checks for said movement,

wherein said output indicator displays, based on said movement data, information indicating that a threshold is met,

wherein said movement data stored in the memory is configured to be downloaded to the computer,

wherein the device further comprises software configured to communicate with the program which presents the downloaded movement data,

wherein said program is configured to produce at least one report based on said movement data,

wherein the memory stores a plurality of thresholds respectively corresponding to a plurality of notifications,

wherein said device is configured to be placed on said user's arm to monitor and record said movement data,

wherein said movement sensor measures movement of said user's arm.

117. (new): The method of claim 20, wherein said storing further comprises storing, in said memory, at least one time stamp associated with said physical movement data.

118. (new): The method of claim 117, wherein the storing further comprises storing, in said memory, a date associated with the at least one time stamp.

119. (new): The method of claim 117, further comprising: retrieving said at least one time stamp from said real-time clock and associating the retrieved time stamp with said physical movement data.

120. (new): The method of claim 117, further comprising: retrieving said at least one time stamp from said real-time clock based on the occurrence of at least one of a plurality of user-defined events.

121. (new): The method of claim 120, further comprising: identifying the occurrence of at least one of the user-defined events based on interpretation of said movement data.

122. (new): The method of claim 20, wherein said storing comprises continuously storing said movement data after battery power is lost from a power source of the portable, self-contained movement measuring device.

123. (new): The method of claim 20, further comprising: continuously monitoring for said physical movement using a movement sensor of the portable, self-contained movement.

124. (new): The method of claim 123, wherein said interpreting comprises: continuously interpreting, based on the user-defined operational parameters, said physical movement data.

125. (new): The method of claim 20, further comprising: displaying information based on said physical movement data using an output indicator of the portable, self-contained movement measuring device.

126. (new): The method of claim 125, wherein said output indicator displays said information based on said physical movement data and at least one time stamp associated with said physical movement data.

127. (new): The method of claim 117, wherein an output indicator of the portable, self-contained movement measuring device displays information based on said physical movement data and the at least one time stamp associated with said physical movement data.

128. (new): The method of claim 20, further comprising: displaying, based on said physical movement data, information indicating that a threshold is met, using an output indicator of the portable, self-contained movement measuring device.

129. (new): The method of claim 128, wherein said threshold is based on information provided by the user.

130. (new): The method of claim 128, further comprising:
storing said information indicating that the threshold is met.

131. (new): The method of claim 130, further comprising:
storing a time stamp associated with said information indicating that the threshold is met.

132. (new): The method of claim 20, further comprising:
indicating a low battery condition, using an output indicator of the portable, self-contained movement measuring device.

133. (new): The method of claim 20, wherein said physical movement data stored in the memory is the interpreted physical movement data, and said stored physical movement data is configured to be downloaded to a computer.

134. (new): The method of claim 133, further comprising:
communicating with external software, wherein the external software is configured to present said interpreted physical movement data to the user.

135. (new): The method of claim 134, wherein said external software runs on a computer.

136. (new): The method of 20, further comprising:
producing a report based on said interpreted physical movement data.

137. (new): The method of 134, further comprising:
producing at least one report based on said interpreted physical movement data using the external software.

138. (new): The method of claim 134, further comprising:
producing at least one history report based on said interpreted physical movement data using the external software.

139. (new): The method of claim 138, wherein said at least one history report includes dates and times of said physical movement data.

140. (new): The method of claim 134, further comprising:
providing additional reports and histories with respect to said interpreted physical movement data, wherein the additional reports and histories are programmed by the user via the external software.

141. (new): The method of claim 133, wherein said physical movement data is configured to be downloaded to said computer via a wired connection.

142. (new): The method of claim 133, wherein said movement data is configured to be downloaded to the computer via a wireless connection.

143. (new): The method of claim 20, further comprising:
recording, based on a threshold being met, the time and date of the threshold being met.

144. (new): The method of claim 143, further comprising:
providing, via an output indicator of the portable, self-contained movement measuring device, a visual indicator regarding the threshold being met.

145. (new): The method of claim 144, further comprising:
receiving the threshold from a user.

146. (new): The method of claim 20, further comprising:
storing a plurality of thresholds respectively corresponding to a plurality of notifications.

147. (new): The method of claim 146, further comprising:

displaying, via an output indicator of the portable, self-contained movement measuring device, one of the notifications in response to one of the plurality of thresholds being met.

148. (new): The method of claim 147, further comprising:
determining whether any of the thresholds are met by interpreting the physical movement data with respect to the thresholds.

149. (new): The method of claim 146, further comprising:
receiving at least one of the plurality of the thresholds from a user.

150. (new): The method of claim 146, wherein the plurality of thresholds are different from each other.

151. (new): The method of claim 146, wherein the plurality of notifications are different visual indicators.

152. (new): The method of claim 150, wherein at least one of the visual indicators includes a blinking indicator.

153. (new): The method of claim 20, wherein the interpreting further comprises determining whether a threshold is met, and the method further comprises:

signaling the occurrence of at least one user-defined event based on the determining of whether the threshold is met.

154. (new): The method of claim 153, wherein the determining further comprises comparing said physical movement data to said threshold.

155. (new): The method of claim 20, wherein said body part is a user's arm, and said measuring the data comprises monitoring and recording the physical movement of said user's arm.

156. (new): The method of claim 155, wherein said measuring the data comprises measuring the data using a movement sensor of the portable, self-contained movement measuring device.

157. (new): The method of claim 20, further comprising:
measuring a walking distance based on the interpreted physical movement data.

158. (new): The method of claim 20, further comprising:
storing, in said memory, (i) at least one time stamp in association with said movement data and (ii) a date associated with the at least one time stamp,
wherein said portable, self-contained movement measuring device constantly checks for said movement;

displaying, based on said physical movement data, information indicating that a threshold is met, using an output indicator of the portable, self-contained movement measuring device,

wherein said physical movement data stored in the memory is the interpreted physical movement data, and said stored physical movement data is configured to be downloaded to a computer;

communicating with external software configured to run on the computer and present said interpreted physical movement data to the user;

producing a report based on said interpreted physical movement data using the external software; and

storing a plurality of thresholds respectively corresponding to a plurality of notifications,

wherein said body part is a user's arm, and said measuring the data comprises monitoring and recording the physical movement of said user's arm.

II. STATUS OF THE CLAIMS AND EXEMPLARY SUPPORT FOR CLAIM AMENDMENTS

Claim No.	Status	Support in Specification
1	Pending	NA
2	Pending	NA
3	Pending	NA
4	Pending	NA
5	Pending	NA
6	Pending	NA
7	Pending	NA
8	Pending	NA
9	Pending	NA
10	Pending	NA
11	Pending	NA
12	Pending	NA
13	Pending	NA
14	Pending	NA
15	Pending	NA
16	Pending	NA
17	Pending	NA
18	Pending	NA
19	Pending	NA
20	Pending	NA
21	Pending	NA
22	Pending	NA
23	Pending	NA
24	Pending	NA
25	Pending	NA
26	Pending	NA
27	Pending	NA
28	Pending	NA
29	Pending	NA
30	New	col. 6, line 7
31	New	col. 6, line 7
32	New	col. 5, line 45; col. 6, line 7
33	New	col. 5, line 45
34	New	col. 5, line 45
35	New	col. 5, lines 47-51
36	New	col. 5, lines 40-41
37	New	col. 6, lines 16-40
38	New	col. 4, lines 5-14
39	New	col. 4, lines 5-14

Request for Ex Parte Reexamination by Patent Owner
U.S. Patent No. 6,059,576

40	New	col. 4, lines 5-14
41	New	col. 5, lines 62 to col. 6, line 3
42	New	col. 5, line 58 to col. 6, line 3
43	New	col. 6, lines 6-9
44	New	col. 6, lines 19-21
45	New	col. 6, lines 27-39
46	New	col. 5, lines 25-27
47	New	col. 8, lines 31-55
48	New	col. 8, lines 31-55
49	New	col. 8, lines 31-55
50	New	col. 8, lines 40-55
51	New	col. 8, lines 40-55
52	New	col. 8, lines 40-55
53	New	col. 8, lines 40-55
54	New	col. 8, lines 40-55
55	New	col. 8, lines 30-55
56	New	col. 8, lines 30-55
57	New	col. 5, line 40 to col. 6, line 15
58	New	col. 4, lines 9-14
59	New	col. 5, line 58 to col. 6, line 3
60	New	col. 5, line 58 to col. 6, line 15
61	New	col. 5, line 58 to col. 6, line 15
62	New	col. 5, line 58 to col. 6, line 15
63	New	col. 5, line 58 to col. 6, line 15
64	New	col. 5, line 58 to col. 6, line 15
65	New	col. 4, lines 5-14
66	New	col. 4, lines 5-14
67	New	Paragraph bridging cols. 7-8
68	New	Paragraph bridging cols. 7-8
69	New	col. 4, line 62
70	New	col. 4, line 62
71	New	col. 3, line 45
72	New	col. 3, line 45
73	New	col. 3, line 45 col. 4, lines 5-14, 62; col. 5, lines 40-41; col. 5, line 47-51; col. 5 lines 58 to col. 6, line 9; col. 6, lines 19-21; col. 6, lines 27-39; col. 8, lines 30-55
74	New	col. 6, line 7
75	New	col. 6, line 7
76	New	col. 5, line 45; col. 6, line 7
77	New	col. 5, line 45
78	New	col. 5, line 45
79	New	col. 5, lines 47-51
80	New	col. 5, lines 40-41
81	New	col. 6, lines 16-40

Request for Ex Parte Reexamination by Patent Owner
U.S. Patent No. 6,059,576

82	New	col. 4, lines 5-14
83	New	col. 4, lines 5-14
84	New	col. 4, lines 5-14
85	New	col. 5, line 62 to col. 6, line 3
86	New	col. 6, lines 6-9
87	New	col. 6, lines 19-21
88	New	col. 6, lines 19-21
89	New	col. 6, lines 27-39
90	New	col. 5, lines 25-27
91	New	col. 8, line 31-55
92	New	col. 8, line 31-55
93	New	col. 8, line 40-55
94	New	col. 8, line 40-55
95	New	col. 8, line 40-55
96	New	col. 8, line 40-55
97	New	col. 8, line 40-55
98	New	col. 8, line 30-45
99	New	col. 5, line 40 to col. 6, line 15
100	New	col. 4, lines 9-14
101	New	col. 5, line 58 to col. 6, line 3
102	New	col. 5, line 58 to col. 6, line 15
103	New	col. 5, line 58 to col. 6, line 15
104	New	col. 5, line 58 to col. 6, line 15
105	New	col. 5, line 58 to col. 6, line 15
106	New	col. 5, line 58 to col. 6, line 15
107	New	col. 5, line 58 to col. 6, line 15
108	New	col. 4, lines 5-14
109	New	col. 4, lines 5-14
110	New	paragraph bridging cols. 7-8
111	New	paragraph bridging cols. 7-8
112	New	col 4, line 62
113	New	col 4, line 62
114	New	col. 3, line 45
115	New	col. 3, line 45
116	New	col. 3, line 45 col. 4, lines 5-14, 62; col. 5, lines 40-41; col. 5, line 47-51; col. 5 lines 58 to col. 6, line 9; col. 6, lines 19-21; col. 6, lines 27-39; col. 8, lines 30-55
117	New	col. 6, line 7
118	New	col. 6, line 7
119	New	col. 5, line 45; col. 6, line 7
120	New	col. 5, line 45; col. 6, line 7
121	New	col. 5, line 45; col. 6, line 7
122	New	col. 5, lines 47-51
123	New	col. 5, lines 40-41

Request for Ex Parte Reexamination by Patent Owner
U.S. Patent No. 6,059,576

124	New	col. 6, lines 16-40
125	New	col. 4, lines 5-14
126	New	col. 4, lines 5-14
127	New	col. 4, lines 5-14
128	New	col. 5, line 62 to col. 6, line 3
129	New	col. 5, line 62 to col. 6, line 3
130	New	col. 6, lines 6-9
131	New	col. 6, lines 19-21
132	New	col. 6, lines 27-39
133	New	col. 8, line 31-55
134	New	col. 8, line 31-55
135	New	col. 8, line 31-55
136	New	col. 8, line 40-55
137	New	col. 8, line 40-55
138	New	col. 8, line 40-55
139	New	col. 8, line 40-55
140	New	col. 8, line 40-55
141	New	col. 8, line 30-45
142	New	col. 8, line 30-45
143	New	col. 5, line 40 to col. 6, line 15
144	New	col. 4, lines 9-14
145	New	col. 5, line 58 to col. 6, line 3
146	New	col. 5, line 58 to col. 6, line 15
147	New	col. 5, line 58 to col. 6, line 15
148	New	col. 5, line 58 to col. 6, line 15
149	New	col. 5, line 58 to col. 6, line 15
150	New	col. 5, line 58 to col. 6, line 15
151	New	col. 4, lines 5-14
152	New	col. 4, lines 5-14
153	New	paragraph bridging cols. 7-8
154	New	paragraph bridging cols. 7-8
155	New	col 4, line 62
156	New	col 4, line 62
157	New	col. 3, line 45
158	New	col. 3, line 45 col. 4, lines 5-14, 62; col. 5, lines 40-41; col. 5, line 47-51; col. 5 lines 58 to col. 6, line 9; col. 6, lines 19-21; col. 6, lines 27-39; col. 8, lines 30-55

Request for Ex Parte Reexamination by Patent Owner
U.S. Patent No. 6,059,576

III. IDENTIFICATION OF EVERY CLAIM FOR WHICH REEXAMINATION IS REQUESTED

The '576 Patent includes claims 1-29. Reexamination is requested for claims 1, 13, 20, and 21.

IV. STATEMENT POINTING OUT EACH SUBSTANTIAL NEW QUESTION OF PATENTABILITY BASED ON CITED PATENTS AND PRINTED PUBLICATIONS

The '576 Patent and the claims being requested to be reexamined

The '576 Patent, for which reexamination is requested, relates to the field of electronic training and safety devices used to monitor human physical activity (col. 1, lines 6-12).

More specifically, independent claims 1, 13, and 20 and dependent claim 21, for which reexamination is requested, are directed to a portable, self-contained device for monitoring movement of body parts during physical activity, a system to aid in training and safety during physical safety, and a method to monitor physical movement of a body part.

Prosecution History

Patent Owner (PO) filed the original utility application for the '576 Patent on November 21, 1997.

The first rejection

The Examiner rejected original independent claims 1, 14, and 21 as anticipated under pre-America Invents Act (pre-AIA) 35 U.S.C. § 102(b) by Stark (Non-final rejection of February 4, 1999). Of note, claims 14 and 21 were later renumbered as claims 13 and 20, respectively, at the time of issuing the '576 Patent.

Further, the Examiner rejected original dependent method claim 22 (which was later renumbered as claim 21 at the time of issuing the '576 Patent) as being obvious under pre-AIA 35 U.S.C. § 103(a) based on Stark in view of Pratt.

The first response dealing with the Stark and Pratt references

In response, PO presented remarks without substantively amending claims 1, 14, 21 or 22¹.

Regarding the Examiner's statement that Stark "broadly discloses the concept of the system and method for monitoring physical movement of the body part" in rejecting claims 1, 14, and 21, PO argued that that

"[t]he Examiner apparently misunderstands the applicant's invention. Stark describes an orthopedic limb immobilization device while applicant's invention is designed to measure an individual's free movement of limb or torso. In particular, Stark's invention is an orthopedic restraining device used to immobilize and rehabilitate injured human limbs by providing controlled resistance to movement of the limb. The device monitors the force exerted by the wearer via the injured limb through stress sensing means. And it is this sensed data which is monitored and recorded by the device. The only real movement measured by Stark's device is the relative angular position of the "distal end sections" of the device (col. 2, line 55-58) about an adjustable hinge. Stark does not describe a highly portable device used to measure torso or limb movement along multiple axes, including distance and speed of the movement, without any restraint to the movement as is taught by applicant's invention. Thus, Stark's disclosure does not anticipate any of the claims made by the applicant in the present invention".

(Response to non-final rejection filed May 4, 1999, emphasis in original)

Additionally, with respect to the § 103 rejection of claim 22, PO argued that

"Pratt, just as with Stark, discloses a device which is a "resisting apparatus" (col. 3, lines 8-9). This is in direct opposition to applicant's device which allows the wearer to move in any desired direction and with any desired speed for purposes of monitoring the wearer's movement. Thus, while both Stark and Pratt disclose devices used to restrain or resist the wearer's movement, applicant's device does not and in fact could not in order for it to be used for its intended purpose. The

¹ Only claim 14 was amended to address a rejection under 35 U.S.C. 112.

wearer of the applicant's device is not restrained in any way, and this is critical in order to monitor the wearer's natural motion for analysis, whether while performing physical labor or athletic drills...Thus, nothing in these two references integrate to form the unique and nonobvious aspects claimed in claims...22..."

(Response to non-final rejection filed May 4, 1999).

The second rejection

In the subsequent Final rejection mailed July 20, 1999, the Examiner maintained the rejection on the grounds that the "Applicant is reading the limitations into the claim which is [*sic*, are] just not there....limitations contained [in the specification] can not be read into the claims for the purpose of avoiding the prior art".

Examiner Interview

Before filing the next response, PO's representative conducted a telephonic interview with the Examiner - the interview included the discussion of claims 1, 14, 21, and 22, along with the Stark and Pratt references (Examiner's Interview Summary mailed October 8, 1999). In addition to Stark and Pratt, two additional references were discussed during the interview - Linial and Prince. Linial was made of record by way of the Information Disclosure Statement filed concurrent with the filing of the original utility application for the '576 Patent in November, 1997. Prince was cited (but not applied) in the Non-final rejection of February 4, 1999.

The Interview Summary described that the claims listed therein were discussed and that a Continued Prosecution Application (CPA) would be filed in response to the Final rejection.

The Linial reference

Linial is direct to “[a]n improved range of motion measuring and displaying device...which includes a modular housing containing a micro-computer and associated circuitry as well as input controls, display and printout facilities, input and output cord connections and a software receiving area which is provided so as to detachably connect to the modular housing diverse programs enabling diverse modes of operation of the invention” (Abstract, Figs. 1, 5, and 9). Linial is also discussed in the background of the ‘576 Patent where it is disclosed that references such as Linial “require that two people simultaneously use the device: the patient/wearer and the operator of the device. The purpose of these devices is to quantitatively determine a range of motion of a human joint in angular degrees... Although the devices disclosed in these patents [such as Linial] serve the purposes for which they are intended, they do not warn the device wearer when the wearer is nearing, or has reached, a potentially dangerous angle of movement” (col. 1, lines 24-36).

The Prince reference

Coming to Prince, it is noted that there is no discussion on the record regarding the Prince reference other than its citation by the Examiner in the Non-final rejection and the Examiner’s notation in the Interview Summary that this reference was discussed during the interview.

Prince relates generally to systems for testing and improving human performance and more specifically to systems for lift task exercise and diagnosis (col. 1, lines 12-16). Prince discloses that “[i]t is a specific object of this invention to provide a lift task system of the type in which the patient interface device is free to move throughout a substantial working area in

a horizontal plane while maintaining accurate control of simulated weight and inertia of the interface device” (col. 2, lines 48-54). Accordingly, Prince discloses “a method for controlling the performance of a lift task by a human subject using an interface means adapted to be grasped and lifted by the human subject with the method involving the steps of:

- a. presetting a simulated mass value for the interface means;
- b. measuring the amount of vertical force exerted on the interface means by the human subject; and
- c. controlling the vertical movement of the interface means in accordance with a prearranged function of the simulated mass value and the amount of vertical force such that the interface means responds to the vertical force in a manner that simulates substantially the inertia of a body having the simulated mass value in a gravitational field” (col. 2, line 57 to col. 3, line 4).

The CPA and Preliminary Amendment

Subsequently, PO amended independent claims 1, 14, and 21 (by way a Preliminary Amendment filed with the CPA on November 22, 1999) to recite, in some variation, a portable, self-contained movement measuring device for measuring data associated with unrestrained movement in any direction. Claim 22 was not amended.

In the Remarks accompanying the Preliminary Amendment, PO stated the following:

"Applicant has amended the independent claims to more distinctly point out the unique aspects of the invention. These inventive aspects include the portability of Applicant's device and its use to measure unrestricted torso or limb movement along multiple axes. Once these limitations are taken into account, the rejections raised by the Examiner based on the patents issued to Stark, Pratt and Plotke no longer apply.

Request for Ex Parte Reexamination by Patent Owner
U.S. Patent No. 6,059,576

The amended claims also distinguish Applicant's claimed invention from those disclosed by Prince and Linial."
(Preliminary Amendment filed November 22, 1999, emphasis in original).

Allowance

In response to the CPA and Preliminary Amendment, the Examiner issued a Notice of Allowance on December 6, 1999.

In the Reasons for Allowance, the Examiner grouped independent method claim 21 with independent apparatus claim 1 and independent system claim 13, stating that

"None of the prior art of record shows the combination of the structure of the claimed portable self-contained device and method for monitoring physical movement of body parts during physical activity comprising the movement sensor capable of measuring data associated with unrestrained movement in any direction and generating signals indicative of the movement, which are the angle and velocity of the movement, the power source, the microprocessor capable of receiving, interpreting, storing and responding to the movement data based on the user-defined operational parameters, at least one user input connected to the microprocessor for controlling the operation of the portable self-contained device, the real-time clock connected to the microprocessor, memory for storing the movement data, and the output indicator connected to the microprocessor for signaling the occurrence of user-defined events, or the combination of the structure of the claimed system to aid in training and safety during physical activity comprising the portable self-contained movement measuring device which comprising [*sic*, comprises] the movement sensor capable of measuring data associated with unrestrained movement in any direction..."

(Notice of Allowance mailed December 6, 1999).

There is a substantial new question of patentability for claims 1, 13, 20 and 21

As discussed above, the references considered by the Examiner during prosecution of the '576 Patent were primarily concerned with measuring restricted or restrained body movement and to the extent that the Examiner considered references that were generally directed to monitoring physical movements of a body part, the Examiner apparently did not find any references that disclosed or suggested attaching a portable, self-contained movement measuring device to said body part for measuring unrestrained movement in any direction.

The newly found prior art, (1) a patent to Flentov *et al.* (U.S. Patent No. 5,636,146, "Flentov"), (2) a patent to Gaudet *et al.* (U.S. Patent No. 6,018,705, "Gaudet"), and (3) a patent to Vock *et al.* (U.S. Patent No. 6,266,623, "Vock"), are relevant in this regard as they present a new, non-cumulative technological teaching, with respect to one or more features of claims 1, 13, 20 and 21, that was not previously considered and discussed on the record during the prosecution of the application that resulted in the '576 Patent for which reexamination is now requested.

In other words, the present request to reexamine claims 1, 13, 20 and 21 is on the basis of new information about preexisting technology which may have escaped review at the time of the initial examination of the patent application.

Flentov raises a substantial new question of patentability for independent claims 1, 13, and 20

Flentov discloses a loft sensor (e.g., system 10 shown in Figs. 1 and 2) which detects the loft time and/or speed of a vehicle, such as a sporting vehicle, during activities of moving and jumping. The loft sensor detects when the vehicle leaves the ground and when the vehicle returns to the ground. Flentov discloses that its "invention can be used, for example, in sporting activities such as snowboarding where users loft into the air on ski jumps and catch "air" time but have no quantitative measure of the actual time lapse in the air. Therefore, users in skiing can use [the] invention to record, store, and playback selected information relating to their sporting day, including the total amount of "air" time for the day and information such as dead time, i.e., time not spent on the slopes" (Abstract).

Although most embodiments of Flentov relate to the loft sensor being mounted to a sporting vehicle such as a ski (e.g., Fig. 2 – system 10 is mounted on ski 26), Flentov contemplates mounting the loft sensor directly on the user (col. 3, lines 64-65 and col. 19, lines 12-16).

Flentov discloses the following about its invention at col. 5, line 65 to col. 6, line 30:

"The system 10 is incorporated into a relatively small housing, shown by the outline [housing] 24...

Briefly, the invention shown in FIG. 1 operates as follows. The housing 24 is attached or mounted to a sporting device, such as a ski or mountain bike, such that a user of the ski or mountain bike can access the system 10. During motion of the ski or mountain bike, the speed sensor 18 sends velocity information (over communication line 11a) to the microprocessor subsystem 12; while the loft sensor 20 sends loft or "air" time information (over communication line 11b) to the microprocessor subsystem 12. The speed information and loft time information are processed by the microprocessor subsystem 12 to quantify actual speed, e.g., in miles per hour, and actual loft time, e.g., in seconds. The actual speed and loft time are thereafter stored in internal memory 13 until, at least, the speed and time data are accessed by a user of the system 10. Upon access through the user interface 14 (communicating with the microprocessor subsystem

Request for Ex Parte Reexamination by Patent Owner
U.S. Patent No. 6,059,576

12 via communication line 11c), a user of the system 10 can command the display of the speed and loft time data (sent across communication line 11d) on the display 16 in order to evaluate his or her performance in the sporting activity."

These new technological teachings in Flentov raise a substantial new question of patentability with respect to claims 1, 13, and 20, as "there is a substantial likelihood that a reasonable examiner would consider the prior art patent or printed publication [i.e., Flentov] important in deciding whether or not the claim is patentable"(MPEP 2242).

Flentov teaches a limitation found to be missing in the prior examination. That is, in view of the above-noted teachings of Flentov, it may teach a portable, self-contained loft sensor for measuring unrestrained movement of said user.

Flentov raises a substantial new question of patentability for claim 21

Flentov discloses a pressure-based speed sensor embodiment at col. 19, lines 23-53 as follows:

"...Pressure sensors according to the invention convert air pressure to an analog voltage. When mounted to a snowboard 220, such as shown in FIGS. 15 and 15A, the pressure sensor 221 is used to determine the altitude of the snowboarder. This voltage is read by the microprocessor subsystem (e.g., the subsystem 12 of FIG. 1) at a fixed rate and differentiated to determine rate of descent or speed in the vertical direction. This may be converted to speed along the path by knowing the grade or angle of descent. Angle of descent is known by predetermining the geometry of the ski path or by the addition of an inclinometer 222 which gives a voltage dependent upon the angle, with respect to vertical, of the platform. The inclinometer 222 measures zero when the ski is traveling along a level path and the pressure sensor is showing a constant pressure. When the ski moves downhill, for example, the inclinometer 222 measures the angle of descent and the pressure sensor measures ever increasing pressure. Since the angle of descent is known, as is the rate of descent, the true speed is determined and displayed.

Those skilled in the art should understand that the elements 221 and 222 are connected in circuit with the further elements of the invention, e.g., the microprocessor subsystem 12 of FIG. 1; and that elements 221 and 222 are shown in FIG. 15 for illustrative purposes only when in fact they exist integrally with the system of the invention, e.g., the system 10 of FIG. 1."

Flentov further discloses obtaining efficiency information for addressing "dead" time.

"This efficiency information is available in accord with the invention because the microprocessor subsystem 12 of FIG. 1 preferably includes a clock element (readily known to those skilled in the art) for indicating processed time over a selectable period (the microprocessor subsystem 12 can in fact include a 24- hour clock element, much the way a digital wrist-watch includes 24-hour information)" (col. 9, lines 27-35).

This additional new technological teaching in Flentov, in conjunction with the other teachings of Flentov noted above, raises a substantial new question of patentability of claim 21, as "there is a substantial likelihood that a reasonable examiner would consider the prior

art patent or printed publication [i.e., Flentov] important in deciding whether or not the claim is patentable"(MPEP 2242).

Flentov teaches a limitation found to be missing in the prior examination. That is, in view of the above-noted teachings of Flentov, it may teach that the data collected by the sensor(s) in Flentov includes velocity data of said movement, angle measurement data taken along at least two orthogonal axes, and related date and time data (claim 21).

Gaudet raises a substantial new question of patentability for independent claims 1, 13, and 20

In Gaudet, “a method and an apparatus are disclosed in which an output of an accelerometer is used to determine: (1) instances at which a foot of a user in locomotion leaves a surface, and (2) instances at which the foot of the user impacts the surface. By measuring the time difference between each instance at which the foot impacts the surface and the following instance at which the foot leaves the surface, several periods of time that the foot was in contact with the surface during strides taken by the user, i.e., several foot contact times, may be measured accurately and reliably...” (col. 2, lines 5-26).

Further, Gaudet discloses “a device for analyzing the motion of a foot relative to a surface includes an accelerometer and a signal processing circuit. The accelerometer is supported in relation to the foot and is configured and arranged to provide an output signal indicative of the acceleration of the foot. The signal processing circuit is coupled to the accelerometer to receive the output signal from it, and is configured to analyze the output signal to determine at least one moment that the foot leaves the surface” (col. 2, line 65 to col. 3, line 7).

In particular, “FIG. 2 illustrates how a device according to the invention may be mounted on a user. Each of devices 20A-20C shown in FIG. 2 has a particular axis in which it senses acceleration, i.e., an acceleration sensing axis. According to one embodiment of the invention, each of the devices should be mounted such that the acceleration sensing axis of the device is oriented substantially parallel to a bottom surface of the foot of the user. For example, device 20A is mounted on the ankle of the user, device 20B is mounted on or within the shoe of the user, and device 20C is mounted on the waist of the user, with the acceleration sensing axes of the devices being oriented as indicated by arrows 80A, 80B and 80C,

respectively. In each case, this positioning of the acceleration sensing axis has been found to produce an output signal that is most strongly indicative of both: (1) the moment at which the foot of the user leaves the surface, and (2) the moment at which the foot of the user comes into contact with the surface..." (col. 4, line 50 to col. 5, line 5).

These new technological teachings in Gaudet raise a substantial new question of patentability with respect to claims 1, 13, and 20, as "there is a substantial likelihood that a reasonable examiner would consider the prior art patent or printed publication [i.e., Gaudet] important in deciding whether or not the claim is patentable"(MPEP 2242).

Gaudet teaches a limitation found to be missing in the prior examination. That is, in view of the above-noted teachings of Gaudet, it may teach a portable, self-contained loft sensor for measuring unrestrained movement of said user.

Vock raises a substantial new question of patentability for independent claims 1, 13, and 20

Vock discloses a system including a loft sensor (e.g., system 10 shown in Figs. 1 and 2) which detects the loft time and/or speed of a vehicle, such as a sporting vehicle, during activities of moving and jumping. The loft sensor detects when the vehicle leaves the ground and when the vehicle returns to the ground. Vock discloses that its "invention thus provides a series of unique sensing technologies which are appropriate for sporting activities such as skiing, snowboarding, windsurfing, skate-boarding, mountain biking, and roller-blading. Specifically, the invention is used to "sense," quantify and communicate to the user selected motions for various sporting activities. These motions include [Air Time, Speed, and Power]..." (col. 24, line 42 to col. 25, line 65).

Although most embodiments of Vock relate to the system being mounted to a sporting vehicle such as a ski (e.g., Fig. 2 – system 10 is mounted on ski 26), Vock contemplates attaching the system to the user instead of the vehicle (col. 13, lines 58-67).

Vock discloses the following about its invention at col. 7, line 57 to col. 8, line 22:

"The system 10 is incorporated into a relatively small housing, shown by the outline [housing] 24...

Briefly, the invention shown in FIG. 1 operates as follows. The housing 24 is attached or mounted to a sporting device, such as a ski or mountain bike, such that a user of the ski or mountain bike can access the system 10. During motion of the ski or mountain bike, the speed sensor 18 sends velocity information (over communication line 11a) to the microprocessor subsystem 12; while the loft sensor 20 sends loft or "air" time information (over communication line 11b) to the microprocessor subsystem 12. The speed information and loft time information are processed by the microprocessor subsystem 12 to quantify actual speed, e.g., in miles per hour, and actual loft time, e.g., in seconds. The actual speed and loft time are thereafter stored in internal memory 13 until, at least, the speed and time data are accessed by a user of the system 10. Upon access through the user interface 14 (communicating with the microprocessor subsystem 12 via communication line 11c), a user of the system 10 can command the display of the speed and loft time data (sent across communication line

11d) on the display 16 in order to evaluate his or her performance in the sporting activity."

These new technological teachings in Vock raise a substantial new question of patentability with respect to claims 1, 13, and 20, as "there is a substantial likelihood that a reasonable examiner would consider the prior art patent or printed publication [i.e., Vock] important in deciding whether or not the claim is patentable"(MPEP 2242).

Vock teaches a limitation found to be missing in the prior examination. That is, in view of the above-noted teachings of Vock, it may teach a portable, self-contained system for measuring unrestrained movement of said user.

**V. DETAILED EXPLANATION OF HOW THE CITED PATENTS AND
PRINTED PUBLICATIONS ARE APPLIED TO EVERY CLAIM FOR
WHICH REEXAMINATION IS REQUESTED**

Application of the art

Reexamination of claims 1, 13, 20, and 21 is requested in view of Flentov.

For the convenience of the Examiner, an element-by-element comparison of the pertinent portions of Flentov and claims 1, 13, 20, and 21 of the '576 Patent for which reexamination is being requested is set forth below. As verified by the element-by-element comparison below, Flentov raises a substantial new question of patentability with respect to claims 1, 13, 20 and 21.

Application of Flentov to claim 1

Claim 1	Application of Flentov
<p>1. A portable, self-contained device for monitoring movement of body parts during physical activity, said device comprising:</p>	<p>For example, at col. 1, lines 60-65, Flentov discloses that “The invention provides... [an] apparatus for determining the loft time of a moving vehicle off of a surface. A loft sensor senses a first condition that is indicative of the vehicle leaving the surface, and further senses a second condition indicative of the vehicle returning to the surface”, where the moving vehicle could be the user (human) (col. 3, lines 64-65 and col. 19, lines 12-16).</p> <p>Further, Flentov’s system 10 is “portable” and “self-contained” as Flentov discloses that “[t]he system 10 is incorporated into a relatively small housing, shown by the outline 24. The housing 24 is preferably arranged to protect the components 12,14,16,18 and 20 [microprocessor subsystem 12, user interface 14, display 16, speed sensor 18, and loft sensor 20] from the elements of nature - such as rain, snow, sand and dust, each of which is expected during the ordinary course of usage on a ski slope and/or mountain bike trail. In addition, the housing 24 is attachable to a vehicle, such as a ski or mountain bike, by means such as a glue or a mechanical mount, e.g., screws”.</p>
<p>a movement sensor capable of measuring data associated with unrestrained movement and generating signals indicative of said movement [[but not unrestrained movement “in any direction”]];</p>	<p>Flentov discloses at col. 6, lines 14-22 that “[d]uring motion of the ski or mountain bike, the speed sensor 18 sends velocity information (over communication line 11a) to the microprocessor subsystem 12; while the loft sensor 20 sends loft or “air” time information (over communication line 11b) to the microprocessor subsystem 12. The speed information and loft time information are processed by the microprocessor subsystem 12 to quantify actual speed, e.g.,</p>

	<p>in miles per hour, and actual loft time, e.g., in seconds”.</p> <p>However, the unrestrained movement that is being measured in Flentov is not measured “in any direction” as required by claim 1. Rather, the “unrestrained movement” being measured in Flentov is restricted to the “forward axis” (parallel to vehicle movement along surface) and the “height axis” (perpendicular to vehicle movement along surface) (e.g., see claim 11 of Flentov, also see Fig. 14A and its corresponding description at col. 19, lines 5-11).</p> <p>Therefore, Flentov does not disclose or even suggest “a movement sensor capable of measuring data associated with unrestrained movement in any direction and generating signals indicative of said movement” as required by claim 1.</p>
<p>a power source;</p>	<p>Flentov discloses at col. 2, lines 2-7 that “a power module such as a battery is included in the apparatus to power the several components”.</p>
<p>a microprocessor connected to said movement sensor and to said power source, said microprocessor capable of receiving, interpreting, storing and responding to said movement data based on user-defined operational parameters;</p>	<p>For example, Flentov discloses that “...the loft sensor of the invention senses a spectrum of information, e.g., a vibrational or sound spectrum, and the microprocessor subsystem determines the first and second conditions relative to a change in the spectrum of information. Further, the microprocessor subassembly interprets the change in the spectrum to determine the loft time” (col. 3, lines 1-7).</p> <p>Further, Flentov discloses that “[b]ecause these spectrums are influenced by the particular activity of a user, e.g., standing in a ski line, a microprocessor subsystem of the invention preferably includes means for</p>

Request for Ex Parte Reexamination by Patent Owner
U.S. Patent No. 6,059,576

	<p>assessing boundary conditions of the spectrum and for excluding certain conditions from the determination of loft time. Accordingly, if a skier is in a lift line, such conditions are effectively ignored...Because these boundary conditions are important in the aspects of the invention which utilize a spectrum of information, the apparatus preferably utilizes a user interface for providing selective external inputs to the microprocessor subsystem and for adjusting the boundary conditions selectively” (col. 3, lines 8-37).</p>
<p>at least one user input connected to said microprocessor for controlling the operation of said device;</p>	<p>For instance, Flentov discloses that “the invention includes a user interface for providing external inputs to the apparatus, including one or more of the following: a start/stop button for selectively starting and stopping the acquisition of data by the apparatus; a display-operate button for activating the display means selectively;...” (col. 2, lines 36-54).</p>
<p>a real-time clock connected to said microprocessor;</p>	<p>Flentov discloses that “the microprocessor subsystem 12 of FIG. 1 preferably includes a clock element (readily known to those skilled in the art) for indicating processed time over a selectable period (the microprocessor subsystem 12 can in fact include a 24- hour clock element, much the way a digital wrist-watch includes 24-hour information)” (col. 9, lines 22-34).</p>
<p>memory for storing said movement data; and</p>	<p>For instance, at col. 6, lines 22-25, Flentov discloses that “[t]he actual speed and loft time are thereafter stored in internal memory 13 until, at least, the speed and time data are accessed by a user of the system 10”.</p>
<p>an output indicator connected to said microprocessor for signaling the occurrence of user-defined events;</p>	<p>Flentov discloses that “the invention includes a user interface for providing external inputs to the apparatus, including one or more of the following:...a speed/loft toggle button for alternatively commanding a display of loft time information and speed information of the vehicle; means for commanding a display of successive records of loft time information selectively;...and means for commanding a display of real activity time” (col. 2, lines 36-</p>

Request for Ex Parte Reexamination by Patent Owner
 U.S. Patent No. 6,059,576

	54).
wherein said movement sensor measures the angle and velocity of said movement.	For example, Flentov discloses “[o]ne preferred aspect of the invention includes a speed sensor, connected to the microprocessor subsystem, which senses a third condition that is indicative of a velocity of the vehicle” (col. 2, lines 15-18). Flentov also discloses that “the inclinometer 222 measures the angle of descent...” (col. 19, lines 39-46).

In view of the foregoing, PO respectfully submits that a substantial new question of patentability exists with respect to claim 1. However, it is further noted that “[i]t is not necessary that a “*prima facie*” case of unpatentability exist as to the claim in order for “a substantial new question of patentability” to be present as to the claim. Thus, “a substantial new question of patentability” as to a patent claim could be present even if the examiner would not necessarily reject the claim as either fully anticipated by, or obvious in view of, the prior art patents or printed publications” (MPEP 2242).

That applies here, as the newly found Flentov reference presents a new, non-cumulative technological teaching, with respect to one or more features of claim 1, that was not previously considered and discussed on the record during the prosecution of the application that resulted in the ‘576 Patent. However, Flentov still does not disclose or suggest all the features of 1 because, as discussed above, it does not disclose measuring unrestrained movement “in any direction” as required by claim 1.

Application of Flentov to claim 13

Claim 13	Application of Flentov
<p>13. A system to aid in training and safety during physical activity, said system comprising: a portable, self-contained movement measuring device, said movement measuring device further comprising</p>	<p>For example, at col. 1, lines 60-65, Flentov discloses that “The invention provides... [an] apparatus for determining the loft time of a moving vehicle off of a surface. A loft sensor senses a first condition that is indicative of the vehicle leaving the surface, and further senses a second condition indicative of the vehicle returning to the surface”, where the moving vehicle could be the user (human) (col. 3, lines 64-65 and col. 19, lines 12-16).</p> <p>Further, Flentov’s system 10 is “portable” and “self-contained” as Flentov discloses that “[t]he system 10 is incorporated into a relatively small housing, shown by the outline 24. The housing 24 is preferably arranged to protect the components 12,14,16,18 and 20 [microprocessor subsystem 12, user interface 14, display 16, speed sensor 18, and loft sensor 20] from the elements of nature - such as rain, snow, sand and dust, each of which is expected during the ordinary course of usage on a ski slope and/or mountain bike trail. In addition, the housing 24 is attachable to a vehicle, such as a ski or mountain bike, by means such as a glue or a mechanical mount, e.g., screws”.</p>
<p>a movement sensor capable of measuring data associated with unrestrained movement and generating signals indicative of said movement [[but not unrestrained movement “in any direction”]];</p>	<p>Flentov discloses at col. 6, lines 14-22 that “[d]uring motion of the ski or mountain bike, the speed sensor 18 sends velocity information (over communication line 11a) to the microprocessor subsystem 12; while the loft sensor 20 sends loft or “air” time information (over communication line 11b) to the microprocessor subsystem 12. The speed information and loft time information are processed by the microprocessor subsystem 12 to quantify actual speed, e.g.,</p>

	<p>in miles per hour, and actual loft time, e.g., in seconds”.</p> <p>However, the unrestrained movement that is being measured in Flentov is not measured “in any direction” as required by claim 13. Rather, the “unrestrained movement” being measured in Flentov is restricted to the “forward axis” (parallel to vehicle movement along surface) and the “height axis” (perpendicular to vehicle movement along surface) (e.g., see claim 11 of Flentov, also see Fig. 14A and its corresponding description at col. 19, lines 5-11).</p> <p>Therefore, Flentov does not disclose or even suggest “a movement sensor capable of measuring data associated with unrestrained movement in any direction and generating signals indicative of said movement” as required by claim 13.</p>
<p>a power source;</p>	<p>Flentov discloses at col. 2, lines 2-7 that “a power module such as a battery is included in the apparatus to power the several components”.</p>
<p>a microprocessor connected to said power source, said microprocessor capable of receiving, interpreting, storing and responding to said movement data based on user-defined operational parameters;</p>	<p>For example, Flentov discloses that “...the loft sensor of the invention senses a spectrum of information, e.g., a vibrational or sound spectrum, and the microprocessor subsystem determines the first and second conditions relative to a change in the spectrum of information. Further, the microprocessor subassembly interprets the change in the spectrum to determine the loft time” (col. 3, lines 1-7).</p> <p>Further, Flentov discloses that “[b]ecause these spectrums are influenced by the particular activity of a user, e.g., standing in a ski line, a microprocessor subsystem of the invention preferably includes means for</p>

Request for Ex Parte Reexamination by Patent Owner
U.S. Patent No. 6,059,576

	<p>assessing boundary conditions of the spectrum and for excluding certain conditions from the determination of loft time. Accordingly, if a skier is in a lift line, such conditions are effectively ignored...Because these boundary conditions are important in the aspects of the invention which utilize a spectrum of information, the apparatus preferably utilizes a user interface for providing selective external inputs to the microprocessor subsystem and for adjusting the boundary conditions selectively” (col. 3, lines 8-37).</p>
<p>at least one user input connected to said microprocessor for controlling the operation of said device;</p>	<p>For instance, Flentov discloses that “the invention includes a user interface for providing external inputs to the apparatus, including one or more of the following: a start/stop button for selectively starting and stopping the acquisition of data by the apparatus; a display-operate button for activating the display means selectively;...” (col. 2, lines 36-54).</p>
<p>a real-time clock connected to said microprocessor;</p>	<p>Flentov discloses that “the microprocessor subsystem 12 of FIG. 1 preferably includes a clock element (readily known to those skilled in the art) for indicating processed time over a selectable period (the microprocessor subsystem 12 can in fact include a 24- hour clock element, much the way a digital wrist-watch includes 24-hour information)” (col. 9, lines 22-34).</p>
<p>memory for storing said movement data;</p>	<p>For instance, at col. 6, lines 22-25, Flentov discloses that “[t]he actual speed and loft time are thereafter stored in internal memory 13 until, at least, the speed and time data are accessed by a user of the system 10”.</p>
<p>at least one input/output port connected to said microprocessor for downloading said data and uploading said operational parameters; and</p>	<p>For instance, Flentov discloses that the microprocessor subsystem 150 includes “interface electronics 156” and “conditioning electronics 158”, where “[t]he user interface 160, such as the interface 14 of FIG. 1, and including the button inputs of FIG. 3, connects to the subsystem such as shown and directly to the conditioning electronics 158” (paragraph bridging cols. 13-14); and “the apparatus preferably utilizes a user</p>

	interface for providing selective external inputs to the microprocessor subsystem and for adjusting the boundary conditions selectively” (col. 3, lines 8-37).
an output indicator connected to said microprocessor;	Flentov discloses that “the invention includes a user interface for providing external inputs to the apparatus, including one or more of the following:...a speed/loft toggle button for alternatively commanding a display of loft time information and speed information of the vehicle; means for commanding a display of successive records of loft time information selectively;...and means for commanding a display of real activity time” (col. 2, lines 36-54).
a computer running a program [[but <u>not</u> a computer running a program "capable of interpreting and reporting said movement data based on said operational parameters]] ; and	Flentov discloses that “FIG. 10 shows microprocessor subsystem 150 constructed according to the invention and including a Central Processing Unit (CPU) 152, memory 154, interface electronics 156, and conditioning electronics 158.... The CPU 152 includes a microprocessor 152a, Read Only Memory (ROM) 152b (used to store instructions that the processor may fetch in executing its program),” (col. 13, line 59 to col. 14, line 25). However, Flentov does not disclose or suggest any computer running a program capable of interpreting and reporting said movement data based on said operational parameters , as required by claim 13.
a download device electronically connected to said movement measuring device and said computer for transmitting said movement data and operational parameters between said movement measuring device and said computer for analysis, reporting and operation purposes;	As noted in the preceding section, the microprocessor subsystem 150 includes “interface electronics 156” and “conditioning electronics 158”, where “[t]he user interface 160, such as the interface 14 of FIG. 1, and including the button inputs of FIG. 3, connects to the subsystem such as shown and directly to the conditioning electronics 158” (paragraph bridging cols. 13-14).
wherein said movement sensor measures the angle and velocity of said movement.	For example, Flentov discloses “[o]ne preferred aspect of the invention includes a speed sensor, connected to the microprocessor subsystem, which senses a third condition that is indicative of a velocity

	of the vehicle” (col. 2, lines 15-18). Flentov also discloses that “the inclinometer 222 measures the angle of descent...” (col. 19, lines 39-46).
--	---

In view of the foregoing, PO respectfully submits that a substantial new question of patentability exists with respect to claim 13. However, it is further noted that “[i]t is not necessary that a “*prima facie*” case of unpatentability exist as to the claim in order for “a substantial new question of patentability” to be present as to the claim. Thus, “a substantial new question of patentability” as to a patent claim could be present even if the examiner would not necessarily reject the claim as either fully anticipated by, or obvious in view of, the prior art patents or printed publications” (MPEP 2242).

That applies here, as the newly found Flentov reference presents a new, non-cumulative technological teaching, with respect to one or more features of claim 13, that was not previously considered and discussed on the record during the prosecution of the application that resulted in the ‘576 Patent. However, Flentov still does not disclose or suggest all the features of 13 because, as discussed above, it does not disclose measuring unrestrained movement “in any direction” as required by claim 13.

Application of Flentov to claim 20

Claim 20	Application of Flentov
<p>20. A method to monitor physical movement of a body part comprising the steps of:</p>	<p>For example, at col. 4, lines 37-45, Flentov discloses that "...the invention provides a method for determining the loft time of a moving vehicle off of a surface", where the moving vehicle could be the user (human) (col. 3, lines 64-65 and col. 19, lines 12-16).</p>
<p>attaching a portable, self-contained movement measuring device to said body part for measuring unrestrained movement [[but not unrestrained movement "in any direction"]];</p>	<p>For example, at col. 19, lines 12-16, Flentov discloses that "the whole of the system according to the invention can be mounted to a user of the system directly, rather than directly to a vehicle"</p> <p>Further, Flentov's system 10 is "portable" and "self-contained" as Flentov discloses that "[t]he system 10 is incorporated into a relatively small housing, shown by the outline 24. The housing 24 is preferably arranged to protect the components 12,14,16,18 and 20 [microprocessor subsystem 12, user interface 14, display 16, speed sensor 18, and loft sensor 20] from the elements of nature - such as rain, snow, sand and dust, each of which is expected during the ordinary course of usage on a ski slope and/or mountain bike trail. In addition, the housing 24 is attachable to a vehicle, such as a ski or mountain bike, by means such as a glue or a mechanical mount, e.g., screws".</p> <p>Plus Flentov's system 10 is attached to said user (body part) for measuring unrestrained movement as Flentov discloses at col. 6, lines 14-22 that "[d]uring motion of the ski or mountain bike, the speed sensor 18 sends velocity information (over communication line 11a) to the microprocessor subsystem 12; while the loft sensor 20 sends loft or "air" time information (over communication line 11b) to the microprocessor subsystem 12. The speed information and loft time</p>

	<p>information are processed by the microprocessor subsystem 12 to quantify actual speed, e.g., in miles per hour, and actual loft time, e.g., in seconds”.</p> <p>However, the unrestrained movement that is being measured in Flentov is not measured “in any direction” as required by claim 20. Rather, the “unrestrained movement” being measured in Flentov is restricted to the “forward axis” (parallel to vehicle movement along surface) and the “height axis” (perpendicular to vehicle movement along surface) (e.g., see claim 11 of Flentov, also see Fig. 14A and its corresponding description at col. 19, lines 5-11).</p> <p>Therefore, Flentov does not disclose or even suggest “attaching a portable, self-contained movement measuring device to said body part for measuring unrestrained movement in any direction” as required by claim 20.</p>
<p>measuring data associated with said physical movement;</p>	<p>For example, as noted above, Flentov discloses at col. 6, lines 14-22 that “[d]uring motion of the ski or mountain bike, the speed sensor 18 sends velocity information (over communication line 11a) to the microprocessor subsystem 12; while the loft sensor 20 sends loft or “air” time information (over communication line 11b) to the microprocessor subsystem 12. The speed information and loft time information are processed by the microprocessor subsystem 12 to quantify actual speed, e.g., in miles per hour, and actual loft time, e.g., in seconds”.</p> <p>However, as noted above, in Flentov the measured data is associated with said physical movement in at most the “forward axis” and the “height axis” – i.e., the measured physical movement is not just “in any direction” as required by claim 20.</p>

<p>interpreting said physical movement data based on user-defined operational parameters and a real-time clock; and</p>	<p>For example, Flentov discloses that efficiency information of a user is available because “the microprocessor subsystem 12 of FIG. 1 preferably includes a clock element (readily known to those skilled in the art) for indicating processed time over a selectable period (the microprocessor subsystem 12 can in fact include a 24- hour clock element, much the way a digital wrist-watch includes 24-hour information)” (col. 9, lines 22-34).</p>
<p>storing said data in memory.</p>	<p>For instance, at col. 6, lines 22-25, Flentov discloses that “[t]he actual speed and loft time are thereafter stored in internal memory 13 until, at least, the speed and time data are accessed by a user of the system 10”.</p>

In view of the foregoing, PO respectfully submits that a substantial new question of patentability exists with respect to claim 20. However, it is further noted that “[i]t is not necessary that a “*prima facie*” case of unpatentability exist as to the claim in order for “a substantial new question of patentability” to be present as to the claim. Thus, “a substantial new question of patentability” as to a patent claim could be present even if the examiner would not necessarily reject the claim as either fully anticipated by, or obvious in view of, the prior art patents or printed publications” (MPEP 2242).

That applies here, as the newly found Flentov reference presents a new, non-cumulative technological teaching, with respect to one or more features of claim 20, that was not previously considered and discussed on the record during the prosecution of the application that resulted in the ‘576 Patent. However, Flentov still does not disclose or suggest all the features of 20 because, as discussed above, it does not disclose measuring unrestrained movement “in any direction” as required by claim 20.

Application of Flentov to claim 21

Claim 21	Application of Flentov
<p>21. The method of claim 20 wherein said physical movement data includes velocity data of said movement, angle measurement data taken along at least two orthogonal axes, and related date and time data.</p>	<p>For example, Flentov discloses “[o]ne preferred aspect of the invention includes a speed sensor, connected to the microprocessor subsystem, which senses a third condition that is indicative of a velocity of the vehicle” (col. 2, lines 15-18).</p> <p>Flentov also discloses that “the inclinometer 222 measures the angle of descent...” (col. 19, lines 39-46).</p> <p>Further, as noted previously, Flentov discloses that efficiency information of a user is available because “the microprocessor subsystem 12 of FIG. 1 preferably includes a clock element (readily known to those skilled in the art) for indicating processed time over a selectable period (the microprocessor subsystem 12 can in fact include a 24- hour clock element, much the way a digital wrist-watch includes 24-hour information)” (col. 9, lines 22-34).</p> <p>To the extent that this portion of Flentov may suggest “date and time data” as claimed, PO submits that this “date and time data” is not “related” to the claimed physical movement data as required by claim 21.</p> <p>In other words, since claim 21 recites that “said physical movement data includes velocity data of said movement, angle measurement data taken along at least two orthogonal axes, and related date and time data”, a skilled artisan would interpret this claim in light of the specification of the ‘576 Patent to mean that the “date and time data” is “related” to the claimed physical movement data.</p> <p>On the other hand, Flentov does not disclose or suggest that the sensed velocity of the vehicle or the measured angle of descent are</p>

	related to date and time data obtained from its 24-hour clock element.
--	---

In view of the foregoing, PO respectfully submits that a substantial new question of patentability exists with respect to claim 21. However, it is further noted that “[i]t is not necessary that a “*prima facie*” case of unpatentability exist as to the claim in order for “a substantial new question of patentability” to be present as to the claim. Thus, “a substantial new question of patentability” as to a patent claim could be present even if the examiner would not necessarily reject the claim as either fully anticipated by, or obvious in view of, the prior art patents or printed publications” (MPEP 2242).

That applies here, as the newly found Flentov reference presents a new, non-cumulative technological teaching, with respect to one or more features of claim 21, that was not previously considered and discussed on the record during the prosecution of the application that resulted in the ‘576 Patent. However, Flentov still does not disclose or suggest all the features of 21 because, as discussed above, it does not disclose that said physical movement data includes velocity data of said movement, angle measurement data taken along at least two orthogonal axes, and “related date and time data” as required by claim 21.

Application of Gaudet to claim 1

Claim 1	Application of Gaudet
<p>1. A portable, self-contained device for monitoring movement of body parts during physical activity, said device comprising:</p>	<ul style="list-style-type: none"> • “The present invention relates to the monitoring of the orthopedic motion of a person and, more particularly, to the measuring of . . . speed and/or pace of a person in locomotion.” (col. 1, lines 7-10); • “A device for analyzing motion of a foot of a person relative to a surface, comprising an accelerometer supported in relation to the foot, the accelerometer being configured and arranged to provide an output signal indicative of motion of the foot during at least one footstep taken by the person . . . and a signal processor coupled to the accelerometer to receive the output signal therefrom. . . .” (col. 19, lines 41-50).
<p>a movement sensor capable of measuring data associated with unrestrained movement and generating signals indicative of said movement [[but not unrestrained movement “in any direction”]];</p>	<ul style="list-style-type: none"> • “A device for analyzing motion of a foot of a person relative to a surface, comprising an accelerometer supported in relation to the foot, the accelerometer being configured and arranged to provide an output signal indicative of motion of the foot during at least one footstep taken by the person” (col. 19, lines 41-46); • Users of the invention are identified as including “a walker, jogger, or runner” (col. 4, lines 30-31) • “[T]he output signal of the accelerometer . . . is fed to a signal processing circuit configured to analyze the signal to determine a moment that the foot leaves the surface.” (col. 2, lines 31-35) • “The accelerometer is supported in relation to the foot and is configured and arranged to provide an output signal

	<p>indicative of the acceleration of the foot. The signal processing circuit is coupled to the accelerometer to receive the output signal from it, and is configured to analyze the output signal to determine at least one moment that the foot leaves the surface.” (col. 2, line 67 to col. 3, line 7)</p> <p>However, the unrestrained movement that is being measured in Gaudet is not measured “in any direction” as required by claim 1. Rather, the “unrestrained movement” being measured in Gaudet is restricted to a direction that is substantially parallel to the bottom surface of the user’s foot (e.g., see claim 3 of Gaudet).</p> <p>In particular, Gaudet discloses that “FIG. 2 illustrates how a device according to the invention may be mounted on a user. Each of devices 20A-20C shown in FIG. 2 has a particular axis in which it senses acceleration, i.e., an acceleration sensing axis. According to one embodiment of the invention, each of the devices should be mounted such that the acceleration sensing axis of the device is oriented substantially parallel to a bottom surface of the foot of the user” (col. 4, line 50 to col. 5, line 5)</p>
<p>a power source;</p>	<p>Gaudet discloses a “battery” in the paragraph bridging cols. 5-6 and a “power supply” at col. 12, lines 41-44.</p>
<p>a microprocessor connected to said movement sensor and to said power source, said microprocessor capable of receiving, interpreting, storing and responding to said movement data based on user-defined operational parameters;</p>	<ul style="list-style-type: none"> • “The accelerometer is supported in relation to the foot and is configured and arranged to provide an output signal indicative of the acceleration of the foot. The signal processing circuit is coupled to the accelerometer to receive the output signal from it, and is configured to analyze the output signal to determine at

	<p>least one moment that the foot leaves the surface.” (col. 2, line 67 to col. 3, line 7)</p> <ul style="list-style-type: none">• [Referring to continuous-loop subroutines] “These routines could be user initiated, or, preferredly, are initiated automatically upon power-up of micro-controller 40.” (col. 8, lines 37-39) <p>The microprocessor is capable of receiving, interpreting, storing and responding to movement data based on user-defined operational parameters:</p> <p>Receiving:</p> <ul style="list-style-type: none">• “[T]he output signal of the accelerometer . . . is fed to a signal processing circuit configured to analyze the signal to determine a moment that the foot leaves the surface.” (col. 2, lines 31-35)• “The accelerometer is supported in relation to the foot and is configured and arranged to provide an output signal indicative of the acceleration of the foot. The signal processing circuit is coupled to the accelerometer to receive the output signal from it, and is configured to analyze the output signal to determine at least one moment that the foot leaves the surface.” (col. 2, line 67 to col. 3, line 7)• “[A] device for determining the rate at which a user in locomotion is moving includes processing circuitry adapted to receive information regarding a foot contact time.” (col. 3, lines 18-21) <p>Interpreting:</p> <ul style="list-style-type: none">• “[T]he output signal of the accelerometer . . . is fed to a signal processing circuit configured to analyze the signal to determine a moment that the foot leaves the surface.” (col. 2, lines 31-35)• “The accelerometer is supported in relation to the foot and is configured and arranged to provide an output signal indicative of the acceleration of the foot.
--	---

	<p>The signal processing circuit is coupled to the accelerometer to receive the output signal from it, and is configured to analyze the output signal to determine at least one moment that the foot leaves the surface.” (col. 2, line 67 to col. 3, line 7)</p> <p>Storing:</p> <ul style="list-style-type: none"> • “Memory unit 28 is coupled to network processing circuitry 30 and is used to store programming and data for network processing circuitry 30 and/or to log data processed by circuitry 30.” (col. 4, lines 24-28) <p>Responding:</p> <ul style="list-style-type: none"> • “By receiving information from the outputs of foot contact time / foot loft time generators 20A and 20B, heart rate monitor 22, and respiratory monitor 24, as well as inputs from any other type of electronic health monitoring device, network processing circuitry 30 is able to process all such information and provide a user with a fitness metric, to help the user attain a peak fitness level in the most efficient manner possible” (col. 4, lines 41-48). <p>Based on user-defined operational parameters:</p> <ul style="list-style-type: none"> • “User interface 32 also is coupled to network processing circuitry and permits a user . . . to input particular operating parameters, or to select particular outputs for display 26A and/or audio or vibrational indicator 26B.” (col. 4, lines 28-34)
<p>at least one user input connected to said microprocessor for controlling the operation of said device;</p>	<ul style="list-style-type: none"> • “User interface 32 also is coupled to network processing circuitry and permits a user . . . to input particular operating parameters, or to select particular outputs

	<p>for display 26A and/or audio or vibrational indicator 26B.” (col. 4, lines 28-34)</p> <ul style="list-style-type: none"> • “User interface 58 may be activated conventionally by means of buttons, switches, or other physically actuated devices, or may be voice activated using a commercially available voice activation device. . . . [U]ser interface 58 may be used, for example: . . . to select any of several possible outputs for the user, e.g., outputs could be displayed on display 56A or could provide a user with an audio or vibrational indication via audio or vibrational indicator 56B, or to select features which are implemented through software routines called automatically responsive to user inputs.” (col. 5, lines 23-31)
<p>a real-time clock connected to said microprocessor;</p>	<ul style="list-style-type: none"> • “[F]oot contact time / foot loft time generator 20 includes a micro-controller having virtually all circuitry, e.g., memory, times and analog-to-digital (A/D) converters, on board” (col. 5, lines 12-15) • “This micro-controller includes on-board memory, A/D converters, and timers.” (col. 6, lines 14-15)
<p>memory for storing said movement data; and</p>	<ul style="list-style-type: none"> • “Memory unit 28 is coupled to network processing circuitry 30 and is used to store programming and data for network processing circuitry 30 and/or to log data processed by circuitry 30.” (col. 4, lines 24-28) • “[F]oot contact time / foot loft time generator 20 includes a micro-controller having virtually all circuitry, e.g., memory, times and analog-to-digital (A/D) converters, on board, so that memory unit 54 need only be used to perform functions such as permanently storing data produced by foot contact time / foot loft time generator 20.” (col. 5,

	lines 12-18)
<p>an output indicator connected to said microprocessor for signaling the occurrence of user-defined events;</p>	<ul style="list-style-type: none"> • “User interface 32 also is coupled to network processing circuitry and permits a user . . . to select particular outputs for display 26A and/or audio or vibrational indicator 26B.” (col. 4, lines 28-34) • <i>See also</i> claims 31-33, reciting using an electronic device to display the rate at which the user is traveling. (col. 20, lines 42-63)
<p>wherein said movement sensor measures the velocity of said movement [[but not “angle” of said movement”]].</p>	<ul style="list-style-type: none"> • “The present invention relates to the monitoring of the orthopedic motion of a person and, more particularly, to the measuring of . . . speed and/or pace of a person in locomotion.” (col. 1, lines 7-10); • “[A] device for determining the rate at which a user in locomotion is moving includes processing circuitry adapted to receive information regarding a foot contact time.” (col. 3, lines 18-21) • “The present inventors have discovered that it is advantageous to use at least two distinct equations to derive the pace of the user based upon the measured foot contact time. That is, for a measured foot contact time that is less than a particular value (e.g., 400 ms), a first equation should be used to derive the pace of the user therefrom, while for a measured foot contact time that is greater than the particular value (e.g., 400 ms), a second equation should be used.” (col. 15, lines 58-65). <p>However, there is no disclosure or even a suggestion in Gaudet that the movement sensor measures the angle of a user’s movement.</p>

In view of the foregoing, PO respectfully submits that a substantial new question of patentability exists with respect to claim 1. However, it is further noted that “[i]t is not necessary that a “*prima facie*” case of unpatentability exist as to the claim in order for “a substantial new question of patentability” to be present as to the claim. Thus, “a substantial new question of patentability” as to a patent claim could be present even if the examiner would not necessarily reject the claim as either fully anticipated by, or obvious in view of, the prior art patents or printed publications” (MPEP 2242).

That applies here, as the newly found Gaudet reference presents a new, non-cumulative technological teaching, with respect to one or more features of claim 1, that was not previously considered and discussed on the record during the prosecution of the application that resulted in the ‘576 Patent. However, Gaudet still does not disclose or suggest all the features of 1 because, as discussed above, it does not disclose at least (i) measuring unrestrained movement “in any direction” and (ii) measuring the angle of said movement, as required by claim 1.

Application of Gaudet to claim 13

Claim 13	Application of Gaudet
<p>13. A system to aid in training [[and safety]] during physical activity, said system comprising: a portable, self-contained movement measuring device, said movement measuring device further comprising</p>	<ul style="list-style-type: none"> • “The present invention relates to the monitoring of the orthopedic motion of a person and, more particularly, to the measuring of . . . speed and/or pace of a person in locomotion.” (col. 1, lines 7-10); • “A device for analyzing motion of a foot of a person relative to a surface, comprising an accelerometer supported in relation to the foot, the accelerometer being configured and arranged to provide an output signal indicative of motion of the foot during at least one footstep taken by the person . . . and a signal processor coupled to the accelerometer to receive the output signal therefrom. . . .” (col. 19, lines 41-50). • “The variable StepCount is reset prior to the user beginning a training regime so that its running total accurately measures the number of footsteps taken by one foot of the user during the training period.” (col. 11, lines 16-19) <p>However, there is no disclosure in Gaudet that its system for monitoring activity of a person is to aid in safety during the activity. (col. 5, lines 5-32)</p>
<p>a movement sensor capable of measuring data associated with unrestrained movement and generating signals indicative of said movement [[but not unrestrained movement “in any direction”]];</p>	<ul style="list-style-type: none"> • “A device for analyzing motion of a foot of a person relative to a surface, comprising an accelerometer supported in relation to the foot, the accelerometer being configured and arranged to provide an output signal indicative of motion of the foot during at least one footstep taken by the person” (col. 19, lines 41-46); • Users of the invention are identified as

	<p>including “a walker, jogger, or runner” (col. 4, lines 30-31)</p> <ul style="list-style-type: none">• “[T]he output signal of the accelerometer . . . is fed to a signal processing circuit configured to analyze the signal to determine a moment that the foot leaves the surface.” (col. 2, lines 31-35)• “The accelerometer is supported in relation to the foot and is configured and arranged to provide an output signal indicative of the acceleration of the foot. The signal processing circuit is coupled to the accelerometer to receive the output signal from it, and is configured to analyze the output signal to determine at least one moment that the foot leaves the surface.” (col. 2, line 67 to col. 3, line 7) <p>However, the unrestrained movement that is being measured in Gaudet is not measured “in any direction” as required by claim 13. Rather, the “unrestrained movement” being measured in Gaudet is restricted to a direction that is substantially parallel to the bottom surface of the user’s foot (e.g., see claim 3 of Gaudet).</p> <p>In particular, Gaudet discloses that “FIG. 2 illustrates how a device according to the invention may be mounted on a user. Each of devices 20A-20C shown in FIG. 2 has a particular axis in which it senses acceleration, i.e., an acceleration sensing axis. According to one embodiment of the invention, each of the devices should be mounted such that the acceleration sensing axis of the device is oriented substantially parallel to a bottom surface of the foot of the user” (col. 4, line 50 to col. 5, line 5)</p>
--	---

<p>a power source;</p>	<p>Gaudet discloses a “battery” in the paragraph bridging cols. 5-6 and a “power supply” at col. 12, lines 41-44.</p>
<p>a microprocessor connected to said power source, said microprocessor capable of receiving, interpreting, storing and responding to said movement data based on user-defined operational parameters;</p>	<ul style="list-style-type: none"> • “The accelerometer is supported in relation to the foot and is configured and arranged to provide an output signal indicative of the acceleration of the foot. The signal processing circuit is coupled to the accelerometer to receive the output signal from it, and is configured to analyze the output signal to determine at least one moment that the foot leaves the surface.” (col. 2, line 67 to col. 3, line 7) <p>The microprocessor is capable of receiving, interpreting, storing and responding to movement data based on user-defined operational parameters:</p> <p>Receiving:</p> <ul style="list-style-type: none"> • “[T]he output signal of the accelerometer . . . is fed to a signal processing circuit configured to analyze the signal to determine a moment that the foot leaves the surface.” (col. 2, lines 31-35) • “The accelerometer is supported in relation to the foot and is configured and arranged to provide an output signal indicative of the acceleration of the foot. The signal processing circuit is coupled to the accelerometer to receive the output signal from it, and is configured to analyze the output signal to determine at least one moment that the foot leaves the surface.” (col. 2, line 67 to col. 3, line 7) • “[A] device for determining the rate at which a user in locomotion is moving includes processing circuitry adapted to receive information regarding a foot contact time.” (col. 3, lines 18-21)

	<p>Interpreting:</p> <ul style="list-style-type: none">• “[T]he output signal of the accelerometer . . . is fed to a signal processing circuit configured to analyze the signal to determine a moment that the foot leaves the surface.” (col. 2, lines 31-35)• “The accelerometer is supported in relation to the foot and is configured and arranged to provide an output signal indicative of the acceleration of the foot. The signal processing circuit is coupled to the accelerometer to receive the output signal from it, and is configured to analyze the output signal to determine at least one moment that the foot leaves the surface.” (col. 2, line 67 to col. 3, line 7) <p>Storing:</p> <ul style="list-style-type: none">• “Memory unit 28 is coupled to network processing circuitry 30 and is used to store programming and data for network processing circuitry 30 and/or to log data processed by circuitry 30.” (col. 4, lines 24-28) <p>Responding:</p> <ul style="list-style-type: none">• “By receiving information from the outputs of foot contact time / foot loft time generators 20A and 20B, heart rate monitor 22, and respiratory monitor 24, as well as inputs from any other type of electronic health monitoring device, network processing circuitry 30 is able to process all such information and provide a user with a fitness metric, to help the user attain a peak fitness level in the most efficient manner possible” (col. 4, lines 41-48). <p>Based on user-defined operational parameters:</p> <ul style="list-style-type: none">• “User interface 32 also is coupled to network processing circuitry and permits
--	---

	<p>a user . . . to input particular operating parameters, or to select particular outputs for display 26A and/or audio or vibrational indicator 26B.” (col. 4, lines 28-34)</p>
<p>at least one user input connected to said microprocessor for controlling the operation of said device;</p>	<ul style="list-style-type: none"> • “User interface 32 also is coupled to network processing circuitry and permits a user . . . to input particular operating parameters, or to select particular outputs for display 26A and/or audio or vibrational indicator 26B.” (col. 4, lines 28-34) • “User interface 58 may be activated conventionally by means of buttons, switches, or other physically actuated devices, or may be voice activated using a commercially available voice activation device. . . . [U]ser interface 58 may be used, for example: . . . to select any of several possible outputs for the user, e.g., outputs could be displayed on display 56A or could provide a user with an audio or vibrational indication via audio or vibrational indicator 56B, or to select features which are implemented through software routines called automatically responsive to user inputs.” (col. 5, lines 23-31)
<p>a real-time clock connected to said microprocessor;</p>	<ul style="list-style-type: none"> • “[F]oot contact time / foot loft time generator 20 includes a micro-controller having virtually all circuitry, e.g., memory, times and analog-to-digital (A/D) converters, on board” (col. 5, lines 12-15) • “This micro-controller includes on-board memory, A/D converters, and timers.” (col. 6, lines 14-15)
<p>memory for storing said movement data;</p>	<ul style="list-style-type: none"> • “Memory unit 28 is coupled to network processing circuitry 30 and is used to store programming and data for network processing circuitry 30 and/or to log data processed by circuitry 30.” (col. 4, lines

	<p>24-28)</p> <ul style="list-style-type: none"> • “[F]oot contact time / foot loft time generator 20 includes a micro-controller having virtually all circuitry, e.g., memory, times and analog-to-digital (A/D) converters, on board, so that memory unit 54 need only be used to perform functions such as permanently storing data produced by foot contact time / foot loft time generator 20.” (col. 5:12-18)
<p>at least one input/output port connected to said microprocessor for downloading said data and uploading said operational parameters; and</p>	<p>No express disclosure is made of an I/O port connected to the microprocessor.</p> <p>However, Gaudet discloses that the computer and other system components “may be linked together, for example, via direct wiring or capacitive coupling, by using radio-frequency (RF) or infra-red (IR) transmitters/receivers, or by any other information transmission medium known to those skilled in the art.” (col. 4, lines 17-21).</p> <p>As such, the disclosure of the possible use of a personal computer to process information from various components of the system (col. 4, lines 23-25) would appear to require the I/O port, as claimed.</p>
<p>an output indicator connected to said microprocessor;</p>	<ul style="list-style-type: none"> • “User interface 32 also is coupled to network processing circuitry and permits a user . . . to select particular outputs for display 26A and/or audio or vibrational indicator 26B.” (col. 4:28-34) <p><i>See also</i> claims 31-33, reciting using an electronic device to display the rate at which the user is traveling. (col. 20:42-63)</p>
<p>a computer running a program capable of interpreting and reporting said movement data based on said operational parameters; and</p>	<p>“Network processing circuitry 30 may include a personal computer, or any other device capable of processing information from the various inputs of network 70.” (col. 4, lines 23-25)</p>
<p>a download device electronically connected to said movement measuring device and said computer for transmitting said movement data and operational parameters between said movement measuring device and said</p>	<p>Gaudet discloses that the computer and other system components “may be linked together, for example, via direct wiring or capacitive coupling, by using radio-frequency (RF) or infra-red (IR) transmitters/receivers, or by</p>

<p>computer for analysis, reporting and operation purposes;</p>	<p>any other information transmission medium known to those skilled in the art.” (col. 4, lines 17-21)</p> <p>As such, the disclosure of the possible use of a personal computer to process information from various components of the system (col. 4, lines 23-25) would appear to require a download device, as claimed.</p>
<p>wherein said movement sensor measures the velocity of said movement [[but not “angle” of said movement”]].</p>	<ul style="list-style-type: none"> • “The present invention relates to the monitoring of the orthopedic motion of a person and, more particularly, to the measuring of . . . speed and/or pace of a person in locomotion.” (col. 1, lines 7-10); • “[A] device for determining the rate at which a user in locomotion is moving includes processing circuitry adapted to receive information regarding a foot contact time.” (col. 3, lines 18-21) • “The present inventors have discovered that it is advantageous to use at least two distinct equations to derive the pace of the user based upon the measured foot contact time. That is, for a measured foot contact time that is less than a particular value (e.g., 400 ms), a first equation should be used to derive the pace of the user therefrom, while for a measured foot contact time that is greater than the particular value (e.g., 400 ms), a second equation should be used.” (col. 15, lines 58-65). <p>However, there is no disclosure or even a suggestion in Gaudet that the movement sensor measures the angle of a user’s movement.</p>

In view of the foregoing, PO respectfully submits that a substantial new question of patentability exists with respect to claim 13. However, it is further noted that “[i]t is not necessary that a “*prima facie*” case of unpatentability exist as to the claim in order for “a substantial new question of patentability” to be present as to the claim. Thus, “a substantial new question of patentability” as to a patent claim could be present even if the examiner would not necessarily reject the claim as either fully anticipated by, or obvious in view of, the prior art patents or printed publications” (MPEP 2242).

That applies here, as the newly found Gaudet reference presents a new, non-cumulative technological teaching, with respect to one or more features of claim 13, that was not previously considered and discussed on the record during the prosecution of the application that resulted in the ‘576 Patent. However, Gaudet still does not disclose or suggest all the features of 13 because, as discussed above, it does not disclose at least (i) a system to aid in safety during physical activity, (ii) measuring unrestrained movement “in any direction”, and (iii) measuring the angle of said movement, as required by claim 13.

Application of Gaudet to claim 20

Claim 20	Application of Gaudet
<p>20. A method to monitor physical movement of a body part comprising the steps of:</p>	<ul style="list-style-type: none"> • “The present invention relates to the monitoring of the orthopedic motion of a person and, more particularly, to the measuring of . . . speed and/or pace of a person in locomotion.” (col. 1, lines 7-10); • Gaudet further discloses “a method for analyzing the motion of a foot relative to a surface includes using an output of an accelerometer to determine a moment that the foot leaves the surface” (col. 2, lines 27-30).
<p>attaching a portable, self-contained movement measuring device to said body part for measuring unrestrained movement [[but <u>not</u> unrestrained movement “in any direction”]];</p>	<ul style="list-style-type: none"> • “A device for analyzing motion of a foot of a person relative to a surface, comprising an accelerometer supported in relation to the foot, the accelerometer being configured and arranged to provide an output signal indicative of motion of the foot during at least one footstep taken by the person” (col. 19, lines 41-46) • “FIG. 2 illustrates how a device according to the invention may be mounted on a user . . . such that the acceleration sensing axis of the device is oriented substantially parallel to a bottom surface of the foot of the user,” (col. 4, lines 50-57) • Users of the invention are identified as including “a walker, jogger, or runner” (col. 4, lines 30-31) <p>However, the unrestrained movement that is being measured in Gaudet is not measured “in any direction” as required by claim 20. Rather, the “unrestrained movement” being measured in Gaudet is</p>

	<p>restricted to a direction that is substantially parallel to the bottom surface of the user's foot (e.g., see claim 3 of Gaudet).</p> <p>In particular, Gaudet discloses that "FIG. 2 illustrates how a device according to the invention may be mounted on a user. Each of devices 20A-20C shown in FIG. 2 has a particular axis in which it senses acceleration, i.e., an acceleration sensing axis. According to one embodiment of the invention, each of the devices should be mounted such that the acceleration sensing axis of the device is oriented substantially parallel to a bottom surface of the foot of the user" (col. 4, line 50 to col. 5, line 5)</p>
<p>measuring data associated with said physical movement;</p>	<ul style="list-style-type: none"> • "A device for analyzing motion of a foot of a person relative to a surface, comprising an accelerometer supported in relation to the foot, the accelerometer being configured and arranged to provide an output signal indicative of motion of the foot during at least one footstep taken by the person . . . and a signal processor coupled to the accelerometer to receive the output signal therefrom. . . ." (col. 19, lines 41-50). • "By measuring the time difference between peak 47W and peak 49W of curve 46W, the foot contact time of the user when the user is in locomotion may be ascertained." (col. 6, lines 54-57) • "[B]y measuring the time difference between high peak 49W and low peak 53W in curve 46W, the foot loft time of the user is ascertainable." (col. 6, lines 62-54) • "[F]oot contact time and foot loft time measurement . . . are obtained, when a user is running, by measuring time differences between high and low peaks . . ." (col. 8, lines 20-22) • "The occurrence of a negative spike event

	<p>causes an ‘air time’ (Ta) timer in micro-controller to stop and a ‘contact time’ (Tc) timer to start.” (col. 9, lines 8-10)</p> <p>However, as noted above, in Gaudet the measured data associated with said physical movement is restricted to a direction that is substantially parallel to the bottom surface of the user’s foot (e.g., see claim 3 of Gaudet).</p>
<p>interpreting said physical movement data based on user-defined operational parameters and a real-time clock; and</p>	<ul style="list-style-type: none"> • “The accelerometer is supported in relation to the foot and is configured and arranged to provide an output signal indicative of the acceleration of the foot. The signal processing circuit is coupled to the accelerometer to receive the output signal from it, and is configured to analyze the output signal to determine at least one moment that the foot leaves the surface.” (col. 2, line 67 to col. 3, line 7) • “[T]he output signal of the accelerometer . . . is fed to a signal processing circuit configured to analyze the signal to determine a moment that the foot leaves the surface.” (col. 2, lines 31-35) • “User interface 32 also is coupled to network processing circuitry 30 and permits a user . . . to input particular operating parameters, or to select particular outputs for display 26A and/or audio or vibrational indicator 26B.” (col. 4, lines 28-34) • “[F]oot contact time / foot loft time generator 20 includes a micro-controller having virtually all circuitry, e.g., memory, times and analog-to-digital (A/D) converters, on board” (col. 5, lines 12-15) • “This micro-controller includes on-board memory, A/D converters, and timers.” (col. 6, lines 14-15) • “By measuring the time difference

	<p>between peak 47W and peak 49W of curve 46W, the foot contact time of the user when the user is in locomotion may be ascertained.” (col. 6, lines 54-57)</p> <ul style="list-style-type: none"> • “[B]y measuring the time difference between high peak 49W and low peak 53W in curve 46W, the foot loft time of the user is ascertainable.” (col. 6, lines 62-54)
<p>storing said data in memory.</p>	<ul style="list-style-type: none"> • “Memory unit 28 is coupled to network processing circuitry 30 and is used to store programming and data for network processing circuitry 30 and/or to log data processed by circuitry 30.” (col. 4, lines 4-28) • “[F]oot contact time / foot loft time generator 20 includes a micro-controller having virtually all circuitry, e.g., memory, times and analog-to-digital (A/D) converters, on board, so that memory unit 54 need only be used to perform functions such as permanently storing data produced by foot contact time / foot loft time generator 20.” (col. 5, lines 12-18)

In view of the foregoing, PO respectfully submits that a substantial new question of patentability exists with respect to claim 20. However, it is further noted that “[i]t is not necessary that a “*prima facie*” case of unpatentability exist as to the claim in order for “a substantial new question of patentability” to be present as to the claim. Thus, “a substantial new question of patentability” as to a patent claim could be present even if the examiner would not necessarily reject the claim as either fully anticipated by, or obvious in view of, the prior art patents or printed publications” (MPEP 2242).

That applies here, as the newly found Gaudet reference presents a new, non-cumulative technological teaching, with respect to one or more features of claim 20, that was not

Request for Ex Parte Reexamination by Patent Owner
U.S. Patent No. 6,059,576

previously considered and discussed on the record during the prosecution of the application that resulted in the '576 Patent. However, Gaudet still does not disclose or suggest all the features of 20 because, as discussed above, it does not disclose at least measuring unrestrained movement "in any direction" as required by claim 20.

Application of Vock to claim 1

Claim 1	Application of Vock
<p>1. A portable, self-contained device for monitoring movement of body parts during physical activity, said device comprising:</p>	<p>Vock “provide[s] apparatus and methods for determining the "air" time of participants in sporting activities such as skiing and mountain biking” (col. 1, lines 58-62).</p> <p>Further, Vock’s system 10 is “portable” and “self-contained” as Vock discloses that “[t]he system 10 is incorporated into a relatively small housing, shown by the outline 24. The housing 24 is preferably arranged to protect the components 12,14,16,18 and 20 [microprocessor subsystem 12, user interface 14, display 16, speed sensor 18, and loft sensor 20] from the elements of nature - such as rain, snow, sand and dust, each of which is expected during the ordinary course of usage on a ski slope and/or mountain bike trail. In addition, the housing 24 is attachable to a vehicle, such as a ski or mountain bike, by means such as a glue or a mechanical mount, e.g., screws” (col. 7, line 57 to col. 8, line 2).</p> <p>Vock discloses that its system can be attached to the user instead of the vehicle (col. 13, lines 58-67).</p>
<p>a movement sensor capable of measuring data associated with unrestrained movement and generating signals indicative of said movement [[but not unrestrained movement “in any direction”]];</p>	<p>Vock discloses at col. 8, lines 6-15 that “[d]uring motion of the ski or mountain bike, the speed sensor 18 sends velocity information (over communication line 11a) to the microprocessor subsystem 12; while the loft sensor 20 sends loft or "air" time information (over communication line 11b) to the microprocessor subsystem 12. The speed information and loft time information are processed by the microprocessor subsystem 12 to quantify actual speed, e.g., in miles per hour, and actual loft time, e.g., in seconds”.</p>

	<p>However, the unrestrained movement that is being measured in Vock is not measured “in any direction” as required by claim 1. Rather, the “unrestrained movement” being measured in Vock is restricted to “upwards” or “downwards” (e.g., see col. 19, lines 60-67 and col. 21, lines 23-30 of Vock with reference to Fig. 14A). Therefore, Vock does not disclose or even suggest “a movement sensor capable of measuring data associated with unrestrained movement in any direction and generating signals indicative of said movement” as required by claim 1.</p>
<p>a power source;</p>	<p>Vock discloses at col. 2, lines 31-33 that “a power module such as a battery is included in the apparatus to power the several components”.</p>
<p>a microprocessor connected to said movement sensor and to said power source, said microprocessor capable of receiving, interpreting, storing and responding to said movement data based on user-defined operational parameters;</p>	<p>For example, Vock discloses that “...the loft sensor of the invention senses a spectrum of information, e.g., a vibrational or sound spectrum, and the microprocessor subsystem determines the first and second conditions relative to a change in the spectrum of information. Further, the microprocessor subassembly interprets the change in the spectrum to determine the loft time” (col. 3, lines 30-36).</p> <p>Further, Vock discloses that “[b]ecause these spectrums are influenced by the particular activity of a user, e.g., standing in a ski line, a microprocessor subsystem of the invention preferably includes means for assessing boundary conditions of the spectrum and for excluding certain conditions from the determination of loft time. Accordingly, if a skier is in a lift line, such conditions are effectively ignored...Because these boundary conditions are important in the aspects of the invention which utilize a spectrum of</p>

Request for Ex Parte Reexamination by Patent Owner
U.S. Patent No. 6,059,576

	information, the apparatus preferably utilizes a user interface for providing selective external inputs to the microprocessor subsystem and for adjusting the boundary conditions selectively” (col. 3, lines 45-67).
at least one user input connected to said microprocessor for controlling the operation of said device;	For instance, Vock discloses that “the invention includes a user interface for providing external inputs to the apparatus, including one or more of the following: a start/stop button for selectively starting and stopping the acquisition of data by the apparatus; a display-operate button for activating the display means selectively;...” (col. 2, line 66 to col. 3, line 16).
a real-time clock connected to said microprocessor;	Vock discloses that “the microprocessor subsystem 12 of FIG. 1 preferably includes a clock element (readily known to those skilled in the art) for indicating processed time over a selectable period (the microprocessor subsystem 12 can in fact include a 24- hour clock element, much the way a digital wrist-watch includes 24-hour information)” (col. 11, lines 18-25).
memory for storing said movement data; and	For instance, at col. 8, lines 15-18, Vock discloses that “[t]he actual speed and loft time are thereafter stored in internal memory 13 until, at least, the speed and time data are accessed by a user of the system 10”.
an output indicator connected to said microprocessor for signaling the occurrence of user-defined events;	Vock discloses that “the invention includes a user interface for providing external inputs to the apparatus, including one or more of the following:...a speed/loft toggle button for alternatively commanding a display of loft time information and speed information of the vehicle; means for commanding a display of successive records of loft time information selectively;...and means for commanding a display of real activity time” (col. 2, line 66 to col. 3, line 16).
wherein said movement sensor measures the angle and velocity of said movement.	For example, Vock discloses “[o]ne preferred aspect of the invention includes a speed sensor, connected to the microprocessor subsystem, which senses a third condition that is indicative of a velocity of the vehicle” (col. 2, lines 45-48). Vock also discloses that “the inclinometer

	222 measures the angle of descent...” (col. 21, lines 61-65).
--	---

In view of the foregoing, PO respectfully submits that a substantial new question of patentability exists with respect to claim 1. However, it is further noted that “[i]t is not necessary that a “*prima facie*” case of unpatentability exist as to the claim in order for “a substantial new question of patentability” to be present as to the claim. Thus, “a substantial new question of patentability” as to a patent claim could be present even if the examiner would not necessarily reject the claim as either fully anticipated by, or obvious in view of, the prior art patents or printed publications” (MPEP 2242).

That applies here, as the newly found Vock reference presents a new, non-cumulative technological teaching, with respect to one or more features of claim 1, that was not previously considered and discussed on the record during the prosecution of the application that resulted in the ‘576 Patent. However, Vock still does not disclose or suggest all the features of 1 because, as discussed above, it does not disclose measuring unrestrained movement “in any direction” as required by claim 1.

Application of Vock to claim 13

Claim 13	Application of Vock
<p>13. A system to aid in training and safety during physical activity, said system comprising: a portable, self-contained movement measuring device, said movement measuring device further comprising</p>	<p>Vock “provide[s] apparatus and methods for determining the "air" time of participants in sporting activities such as skiing and mountain biking” (col. 1, lines 58-62).</p> <p>Further, Vock’s system 10 is “portable” and “self-contained” as Vock discloses that “[t]he system 10 is incorporated into a relatively small housing, shown by the outline 24. The housing 24 is preferably arranged to protect the components 12,14,16,18 and 20 [microprocessor subsystem 12, user interface 14, display 16, speed sensor 18, and loft sensor 20] from the elements of nature - such as rain, snow, sand and dust, each of which is expected during the ordinary course of usage on a ski slope and/or mountain bike trail. In addition, the housing 24 is attachable to a vehicle, such as a ski or mountain bike, by means such as a glue or a mechanical mount, e.g., screws” (col. 7, line 57 to col. 8, line 2).</p> <p>Vock discloses that its system can be attached to the user instead of the vehicle (col. 13, lines 58-67).</p>
<p>a movement sensor capable of measuring data associated with unrestrained movement and generating signals indicative of said movement [[but <u>not</u> unrestrained movement “in any direction”]];</p>	<p>Vock discloses at col. 8, lines 6-15 that “[d]uring motion of the ski or mountain bike, the speed sensor 18 sends velocity information (over communication line 11a) to the microprocessor subsystem 12; while the loft sensor 20 sends loft or "air" time information (over communication line 11b) to the microprocessor subsystem 12. The speed information and loft time information are processed by the microprocessor subsystem 12 to quantify actual speed, e.g., in miles per hour, and actual loft time, e.g., in</p>

	<p>seconds”.</p> <p>However, the unrestrained movement that is being measured in Vock is not measured “in any direction” as required by claim 13. Rather, the “unrestrained movement” being measured in Vock is restricted to “upwards” or “downwards” (e.g., see col. 19, lines 60-67 and col. 21, lines 23-30 of Vock with reference to Fig. 14A). Therefore, Vock does not disclose or even suggest “a movement sensor capable of measuring data associated with unrestrained movement in any direction and generating signals indicative of said movement” as required by claim 13.</p>
<p>a power source;</p>	<p>Vock discloses at col. 2, lines 31-33 that “a power module such as a battery is included in the apparatus to power the several components”.</p>
<p>a microprocessor connected to said power source, said microprocessor capable of receiving, interpreting, storing and responding to said movement data based on user-defined operational parameters;</p>	<p>For example, Vock discloses that “...the loft sensor of the invention senses a spectrum of information, e.g., a vibrational or sound spectrum, and the microprocessor subsystem determines the first and second conditions relative to a change in the spectrum of information. Further, the microprocessor subassembly interprets the change in the spectrum to determine the loft time” (col. 3, lines 30-36).</p> <p>Further, Vock discloses that “[b]ecause these spectrums are influenced by the particular activity of a user, e.g., standing in a ski line, a microprocessor subsystem of the invention preferably includes means for assessing boundary conditions of the spectrum and for excluding certain conditions from the determination of loft time. Accordingly, if a skier is in a lift line, such conditions are effectively ignored...Because these boundary</p>

Request for Ex Parte Reexamination by Patent Owner
U.S. Patent No. 6,059,576

	conditions are important in the aspects of the invention which utilize a spectrum of information, the apparatus preferably utilizes a user interface for providing selective external inputs to the microprocessor subsystem and for adjusting the boundary conditions selectively” (col. 3, lines 45-67).
at least one user input connected to said microprocessor for controlling the operation of said device;	For instance, Vock discloses that “the invention includes a user interface for providing external inputs to the apparatus, including one or more of the following: a start/stop button for selectively starting and stopping the acquisition of data by the apparatus; a display-operate button for activating the display means selectively;...” (col. 2, line 66 to col. 3, line 16).
a real-time clock connected to said microprocessor;	Vock discloses that “the microprocessor subsystem 12 of FIG. 1 preferably includes a clock element (readily known to those skilled in the art) for indicating processed time over a selectable period (the microprocessor subsystem 12 can in fact include a 24- hour clock element, much the way a digital wrist-watch includes 24-hour information)” (col. 11, lines 18-25).
memory for storing said movement data;	For instance, at col. 8, lines 15-18, Vock discloses that “[t]he actual speed and loft time are thereafter stored in internal memory 13 until, at least, the speed and time data are accessed by a user of the system 10”.
at least one input/output port connected to said microprocessor for downloading said data and uploading said operational parameters; and	For instance, “[a]s shown in FIG. 22, a pair of power meters 600 is also used to quantify competitions such as mogul competitions. One power meter 600A mounts to the ski 602, and another power meter 600B mounts or attaches to the user's upper body 604; and an RF signal generator 606 communicates (via antenna 606a) the power information to a controller at a base facility 608 (e.g., a judges center for judging the mogul skiers). Those skilled in the art should appreciate that one or both power meters 600 can communicate the information to the base, as shown; however, one power meter can also communicate to the other power meter so that one communicates to the base. However, in either case, an RF

	<p>transmitter and receiver is needed at each meter. Alternatively, other inter-power meter communication paths are needed, e.g., wiring, laser or IR data paths, and other techniques known to those in the art.</p> <p>...A computer at the base station 608 can easily divide one signal by the other to get a ratio of the two meters 600 during the run. The meters 600 start transmitting data at the starting gate 610 and continue to give data to the base 608 during the whole run on the slope 612” (col. 25, line 66 to col. 26, line 30).</p> <p>“The accelerometer 624 output can also be processed through an RMS circuit. The Root Mean Square acceleration is then determined from the following formula:</p> $A_{\text{RMS}} = \frac{1}{T} \left[\int_0^T A^2(t) dt \right]^{\frac{1}{2}}$ <p>where T is the period of the measurement and A (t) is the instantaneous accelerometer output at any time t. The period T may be varied by the user and the output is a staircase where each staircase is of width T” (col. 27, lines 48-59).</p> <p>In another embodiment, Vock discloses that the microprocessor subsystem 150 includes “interface electronics 156” and “conditioning electronics 158”, where “[t]he user interface 160, such as the interface 14 of FIG. 1, and including the button inputs of FIG. 3, connects to the subsystem such as shown and directly to the conditioning electronics 158” (paragraph bridging cols. 15-16); and “the apparatus preferably utilizes a user interface for providing selective external inputs to the microprocessor subsystem and for adjusting the boundary conditions selectively” (col. 3, lines 37-67).</p>
<p>an output indicator connected to said microprocessor;</p>	<p>Vock discloses that “the invention includes a user interface for providing external inputs to the apparatus, including one or more of the</p>

	<p>following:...a speed/loft toggle button for alternatively commanding a display of loft time information and speed information of the vehicle; means for commanding a display of successive records of loft time information selectively;...and means for commanding a display of real activity time” (col. 2, line 66 to col. 3, line 16).</p>
<p>a computer running a program capable of interpreting and reporting said movement data based on said operational parameters; and</p>	<p>For instance, “[a]s shown in FIG. 22, a pair of power meters 600 is also used to quantify competitions such as mogul competitions. One power meter 600A mounts to the ski 602, and another power meter 600B mounts or attaches to the user’s upper body 604; and an RF signal generator 606 communicates (via antenna 606a) the power information to a controller at a base facility 608 (e.g., a judges center for judging the mogul skiers). Those skilled in the art should appreciate that one or both power meters 600 can communicate the information to the base, as shown; however, one power meter can also communicate to the other power meter so that one communicates to the base. However, in either case, an RF transmitter and receiver is needed at each meter. Alternatively, other inter-power meter communication paths are needed, e.g., wiring, laser or IR data paths, and other techniques known to those in the art. ...A computer at the base station 608 can easily divide one signal by the other to get a ratio of the two meters 600 during the run. The meters 600 start transmitting data at the starting gate 610 and continue to give data to the base 608 during the whole run on the slope 612” (col. 25, line 66 to col. 26, line 30).</p> <p>“The accelerometer 624 output can also be processed through an RMS circuit. The Root Mean Square acceleration is then determined from the following formula:</p> $A_{RMS} = \frac{1}{T} \left[\int_0^T A^2(t) dt \right]^{\frac{1}{2}}$

Request for Ex Parte Reexamination by Patent Owner
U.S. Patent No. 6,059,576

	<p>where T is the period of the measurement and A (t) is the instantaneous accelerometer output at any time t. The period T may be varied by the user and the output is a staircase where each staircase is of width T” (col. 27, lines 48-59).</p>
<p>a download device electronically connected to said movement measuring device and said computer for transmitting said movement data and operational parameters between said movement measuring device and said computer for analysis, reporting and operation purposes;</p>	<p>As noted in the preceding section, Vock discloses that “[t]hose skilled in the art should appreciate that one or both power meters 600 can communicate the information to the base, as shown; however, one power meter can also communicate to the other power meter so that one communicates to the base. However, in either case, an RF transmitter and receiver is needed at each meter. Alternatively, other inter-power meter communication paths are needed, e.g., wiring, laser or IR data paths, and other techniques known to those in the art” (col. 25, line 66 to col. 26, line 30).</p>
<p>wherein said movement sensor measures the angle and velocity of said movement.</p>	<p>For example, Vock discloses “[o]ne preferred aspect of the invention includes a speed sensor, connected to the microprocessor subsystem, which senses a third condition that is indicative of a velocity of the vehicle” (col. 2, lines 45-48). Vock also discloses that “the inclinometer 222 measures the angle of descent...” (col. 21, lines 61-65).</p>

In view of the foregoing, PO respectfully submits that a substantial new question of patentability exists with respect to claim 13. However, it is further noted that “[i]t is not necessary that a “*prima facie*” case of unpatentability exist as to the claim in order for “a substantial new question of patentability” to be present as to the claim. Thus, “a substantial new question of patentability” as to a patent claim could be present even if the examiner

would not necessarily reject the claim as either fully anticipated by, or obvious in view of, the prior art patents or printed publications” (MPEP 2242).

That applies here, as the newly found Vock reference presents a new, non-cumulative technological teaching, with respect to one or more features of claim 13, that was not previously considered and discussed on the record during the prosecution of the application that resulted in the ‘576 Patent. However, Vock still does not disclose or suggest all the features of 13 because, as discussed above, it does not disclose measuring unrestrained movement “in any direction” as required by claim 13.

Application of Vock to claim 20

Claim 20	Application of Vock
<p>20. A method to monitor physical movement of a body part comprising the steps of:</p>	<p>For example, at col. 5, lines 1-8, Vock discloses that "...the invention provides a method for determining the loft time of a moving vehicle off of a surface".</p>
<p>attaching a portable, self-contained movement measuring device to said body part for measuring unrestrained movement [[but not unrestrained movement "in any direction"]];</p>	<p>For example, Vock discloses that its system can be attached to the user instead of the vehicle (col. 13, lines 58-67)</p> <p>Further, Vock's system 10 is "portable" and "self-contained" as Vock discloses that "[t]he system 10 is incorporated into a relatively small housing, shown by the outline 24. The housing 24 is preferably arranged to protect the components 12,14,16,18 and 20 [microprocessor subsystem 12, user interface 14, display 16, speed sensor 18, and loft sensor 20] from the elements of nature - such as rain, snow, sand and dust, each of which is expected during the ordinary course of usage on a ski slope and/or mountain bike trail. In addition, the housing 24 is attachable to a vehicle, such as a ski or mountain bike, by means such as a glue or a mechanical mount, e.g., screws" (col. 7, line 57 to col. 8, line 2).</p> <p>Vock discloses at col. 8, lines 6-15 that "[d]uring motion of the ski or mountain bike, the speed sensor 18 sends velocity information (over communication line 11a) to the microprocessor subsystem 12; while the loft sensor 20 sends loft or "air" time information (over communication line 11b) to the microprocessor subsystem 12. The speed information and loft time information are processed by the microprocessor subsystem 12 to quantify actual speed, e.g., in miles per hour, and actual loft time, e.g., in seconds".</p>

	<p>However, the unrestrained movement that is being measured in Vock is not measured “in any direction” as required by claim 20. Rather, the “unrestrained movement” being measured in Vock is restricted to “upwards” or “downwards” (e.g., see col. 19, lines 60-67 and col. 21, lines 23-30 of Vock with reference to Fig. 14A). Therefore, Vock does not disclose or even suggest “a movement sensor capable of measuring data associated with unrestrained movement in any direction and generating signals indicative of said movement” as required by claim 20.</p>
<p>measuring data associated with said physical movement;</p>	<p>For example, as noted above, Vock discloses at col. 8, lines 6-15 that “[d]uring motion of the ski or mountain bike, the speed sensor 18 sends velocity information (over communication line 11a) to the microprocessor subsystem 12; while the loft sensor 20 sends loft or “air” time information (over communication line 11b) to the microprocessor subsystem 12. The speed information and loft time information are processed by the microprocessor subsystem 12 to quantify actual speed, e.g., in miles per hour, and actual loft time, e.g., in seconds”.</p> <p>However, as noted above, in Vock the measured data associated with said physical movement is restricted to “upwards” or “downwards” (e.g., see col. 19, lines 60-67 and col. 21, lines 23-30 of Vock with reference to Fig. 14A).</p>
<p>interpreting said physical movement data based on user-defined operational parameters and a real-time clock; and</p>	<p>For example, Vock discloses that “...the loft sensor of the invention senses a spectrum of information, e.g., a vibrational or sound spectrum, and the microprocessor subsystem determines the first and second conditions relative to a change in the spectrum of information. Further, the microprocessor subassembly interprets the change in the spectrum to determine the loft time” (col. 3, lines 30-36).</p>

	<p>Further, Vock discloses that “[b]ecause these spectrums are influenced by the particular activity of a user, e.g., standing in a ski line, a microprocessor subsystem of the invention preferably includes means for assessing boundary conditions of the spectrum and for excluding certain conditions from the determination of loft time. Accordingly, if a skier is in a lift line, such conditions are effectively ignored...Because these boundary conditions are important in the aspects of the invention which utilize a spectrum of information, the apparatus preferably utilizes a user interface for providing selective external inputs to the microprocessor subsystem and for adjusting the boundary conditions selectively” (col. 3, lines 45-67).</p> <p>Vock also discloses that “the microprocessor subsystem 12 of FIG. 1 preferably includes a clock element (readily known to those skilled in the art) for indicating processed time over a selectable period (the microprocessor subsystem 12 can in fact include a 24- hour clock element, much the way a digital wrist-watch includes 24-hour information)” (col. 11, lines 18-25)</p>
<p>storing said data in memory.</p>	<p>For instance, at col. 8, lines 15-18, Vock discloses that “[t]he actual speed and loft time are thereafter stored in internal memory 13 until, at least, the speed and time data are accessed by a user of the system 10”.</p>

In view of the foregoing, PO respectfully submits that a substantial new question of patentability exists with respect to claim 20. However, it is further noted that “[i]t is not necessary that a “*prima facie*” case of unpatentability exist as to the claim in order for “a substantial new question of patentability” to be present as to the claim. Thus, “a substantial

new question of patentability” as to a patent claim could be present even if the examiner would not necessarily reject the claim as either fully anticipated by, or obvious in view of, the prior art patents or printed publications” (MPEP 2242).

That applies here, as the newly found Vock reference presents a new, non-cumulative technological teaching, with respect to one or more features of claim 20, that was not previously considered and discussed on the record during the prosecution of the application that resulted in the ‘576 Patent. However, Vock still does not disclose or suggest all the features of 20 because, as discussed above, it does not disclose measuring unrestrained movement “in any direction” as required by claim 20.

VII. NEW CLAIMS

Claims 30-158 have been added. All of the amendments to the claims are fully supported by the specification. Each one of claims 30-158 depend, either directly or indirectly, from claims 1, 13, or 20 and are, therefore, each separately patentable as it has been shown above that claims 1, 13, and 20 are patentable over the newly found references.

Moreover, the features set forth in new claims 30-158 are not disclosed or even suggested by the newly found references.

Claims 30, 74, and 117

For instance, the newly found references do not teach or suggest storing, in the memory, at least one time stamp in association with said movement data as set forth in some variation in claims 30, 74, and 117.

Claims 31, 75, and 118

For instance, the newly found references do not teach or suggest storing, in the memory, a date associated with the at least one time stamp at least one time stamp in association with said movement data as set forth in some variation in claims 31, 75, and 118.

Claims 41, 85, and 128

For instance, the newly found references do not teach or suggest displaying, based on said movement data, information indicating that a threshold is met as set forth in some variation in claims 41, 85, and 128.

Claims 42, 86, and 129

For instance, the newly found references do not teach or suggest that the threshold is based on information provided by the user as set forth in some variation in claims 42, 86, and 129.

Claims 43, 87, and 130

For instance, the newly found references do not teach or suggest storing, in the memory, said information indicating that the threshold is met as set forth in some variation in claims 43, 87, and 130.

Claims 51, 94, and 137

For instance, the newly found references do not teach or suggest that the external software is configured to interpret said movement data and produce at least one report as set forth in some variation in claims 51, 94, and 137.

Claims 57, 100, and 143

For instance, the newly found references do not teach or suggest recording, based on a threshold being met, the time and date of the threshold being met as set forth in some variation in claims 57, 100, and 143.

Claims 58, 101, and 144

For instance, the newly found references do not teach or suggest the output indicator providing a visual indicator to the user regarding the threshold being met as set forth in some variation in claims 58, 101, and 144.

Claims 60, 103, and 146

For instance, the newly found references do not teach or suggest storing a plurality of thresholds respectively corresponding to a plurality of notifications as set forth in some variation in claims 60, 103, and 146.

Claims 61, 104, and 147

For instance, the newly found references do not teach or suggest that when one of the plurality of thresholds is met, the output indicator displays a corresponding one of the notifications as set forth in some variation in claims 61, 104, and 147.

Request for Ex Parte Reexamination by Patent Owner
U.S. Patent No. 6,059,576

VIII. CONCLUSION

In view of the foregoing, reexamination of claims 1, 13, 20, and 21 of the '576 Patent is respectfully requested, and it is respectfully requested that reexamination be granted, and that all claims, including claims 1, 13, 20 and 21, be held patentable in view of the differences between the subject claims and the newly found references.

The USPTO is directed and authorized to charge all Requester's required fees associated with this request to Deposit Account No. 19-4880. Please also credit any overpayments to said Deposit Account.

Respectfully submitted,

/William H. Mandir/
William H. Mandir
Registration No. 32,156

SUGHRUE MION, PLLC
Telephone: 202.293.7060
Facsimile: 202.293.7860

WASHINGTON OFFICE

23373

CUSTOMER NUMBER

Date: April 4, 2014



US006059576A

United States Patent [19]
Brann

[11] **Patent Number:** **6,059,576**
[45] **Date of Patent:** ***May 9, 2000**

[54] **TRAINING AND SAFETY DEVICE, SYSTEM AND METHOD TO AID IN PROPER MOVEMENT DURING PHYSICAL ACTIVITY**
[76] Inventor: **Theodore L. Brann**, P.O. Box 1897, Mission, Tex. 78572
[*] Notice: This patent issued on a continued prosecution application filed under 37 CFR 1.53(d), and is subject to the twenty year patent term provisions of 35 U.S.C. 154(a)(2).

5,394,888	3/1995	Stone et al. .
5,398,697	3/1995	Spielman .
5,435,321	7/1995	McMillen et al. .
5,462,065	10/1995	Cusimano .
5,469,862	11/1995	Kovacevic .
5,474,088	12/1995	Zaharkin et al. .
5,513,651	5/1996	Cusimano et al. .
5,588,444	12/1996	Petragallo .
5,621,667	4/1997	Waters .
5,715,160	2/1998	Plotke 482/902 X

Primary Examiner—Joe H. Cheng
Attorney, Agent, or Firm—Locke Liddell & Sapp LLP

[21] Appl. No.: **08/976,228**
[22] Filed: **Nov. 21, 1997**
[51] **Int. Cl.**⁷ **A63B 69/00**; G09B 9/00
[52] **U.S. Cl.** **434/247**; 128/782; 600/595; 601/34; 482/8; 482/901; 340/686.1; 702/101
[58] **Field of Search** 434/118, 247, 434/365; 482/3, 4, 6, 8, 9, 92, 137, 900-903; 128/897, 905, 782; 600/301, 502, 587, 594, 595; 601/5, 33, 34; 73/379.01, 379.06, 379.08; 340/573.1, 573.7, 686.1, 689; 364/167.12; 702/19, 41, 101, 141, 174

[57] **ABSTRACT**

An electronic device, system and method to monitor and train an individual on proper motion during physical movement. The system employs an electronic device which tracks and monitors an individual's motion through the use of an accelerometer capable of measuring parameters associated with the individual's movement. The device also employs a user-programmable microprocessor which receives, interprets, stores and responds to data relating to the movement parameters based on customizable operation parameters, a real-time clock connected to the microprocessor, memory for storing the movement data, a power source, a port for downloading the data from the device to other computation or storage devices contained within the system, and various input and output components. The downloadable, self-contained device can be worn at various positions along the torso or appendages being monitored depending on the specific physical task being performed. The device also detects the speed of movements made while the device is being worn. When a pre-programmed recordable event is recognized, the device records the time and date of the occurrence while providing feedback to the wearer via visual, audible and/or tactile warnings.

[56] **References Cited**
U.S. PATENT DOCUMENTS

4,571,682	2/1986	Silverman et al.	482/903 X
4,665,928	5/1987	Linial et al. .	
4,911,427	3/1990	Matsumoto et al.	482/902 X
4,912,638	3/1990	Pratt, jr.	482/903 X
4,934,694	6/1990	McIntosh	482/902 X
5,042,505	8/1991	Mayer et al. .	
5,052,375	10/1991	Stark et al.	482/902 X
5,128,655	7/1992	Shore .	
5,348,519	9/1994	Prince et al.	482/903 X
5,373,858	12/1994	Rose et al. .	
5,375,610	12/1994	LaCourse et al. .	

29 Claims, 9 Drawing Sheets

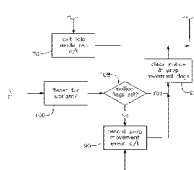
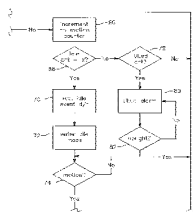
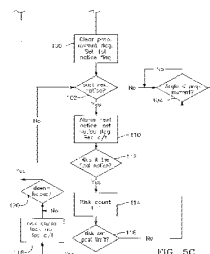
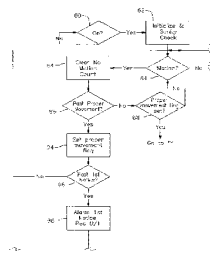

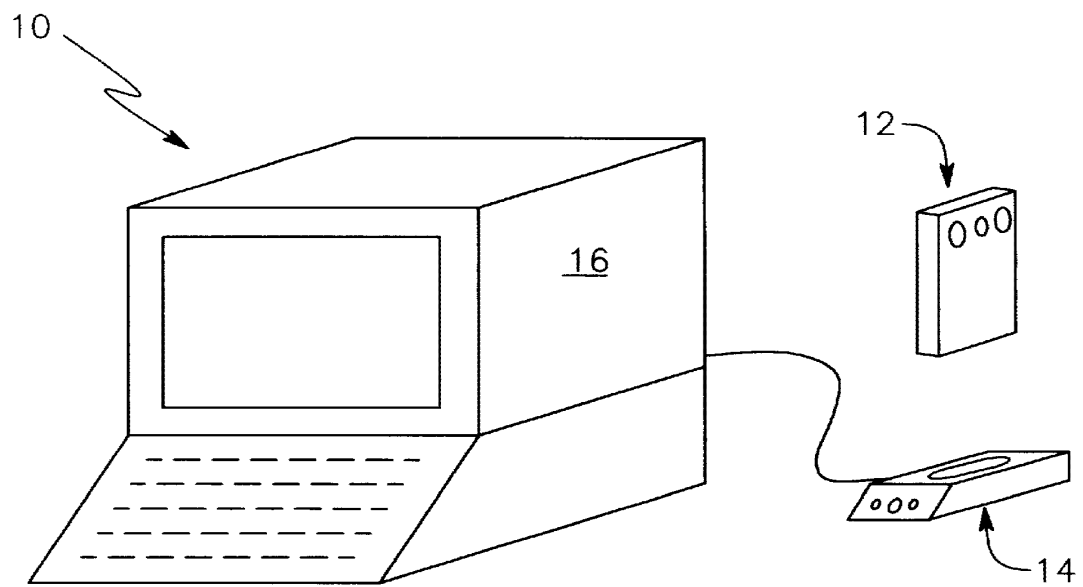

FIG. 1

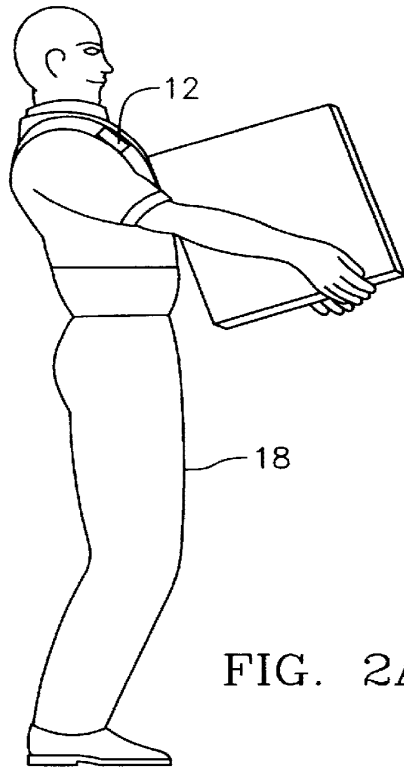

FIG. 2A

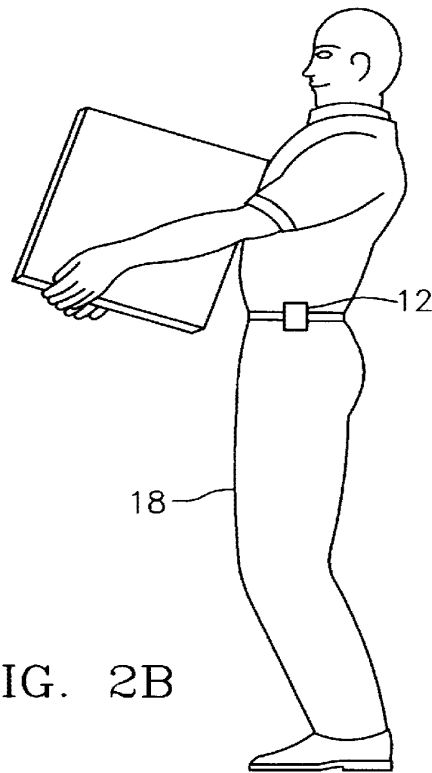

FIG. 2B

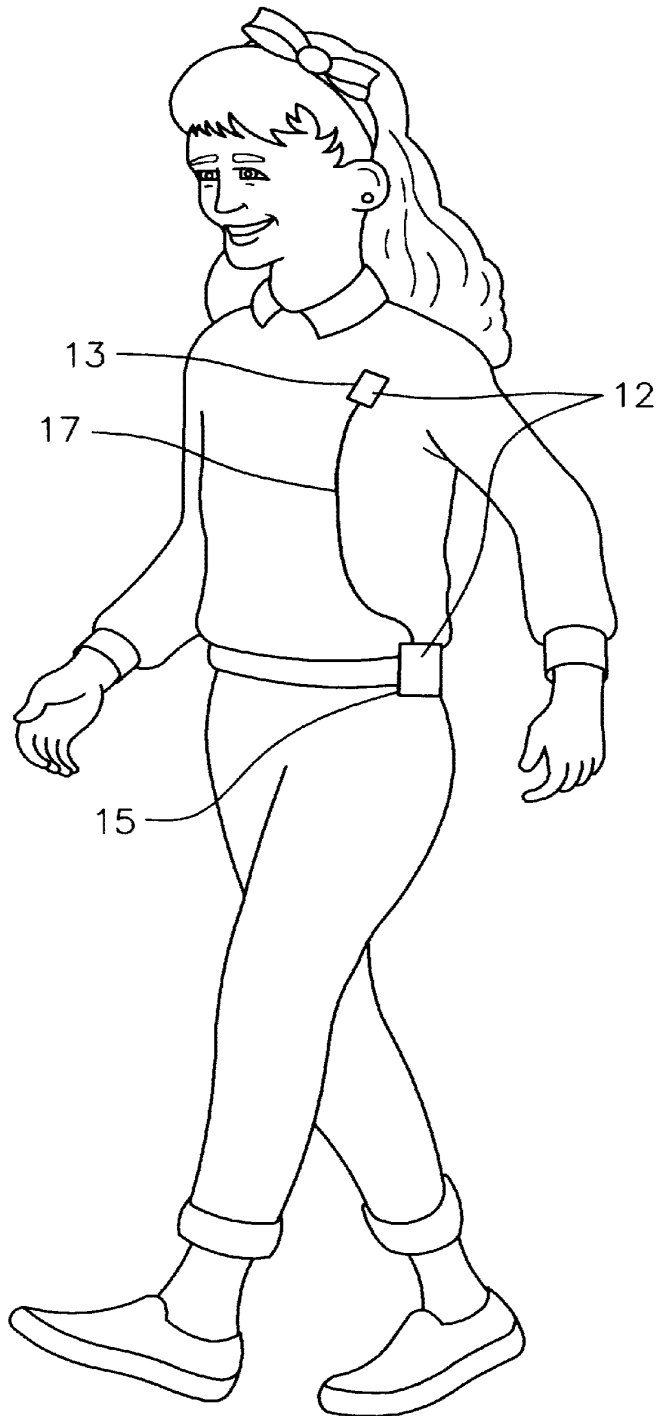

FIG. 2C

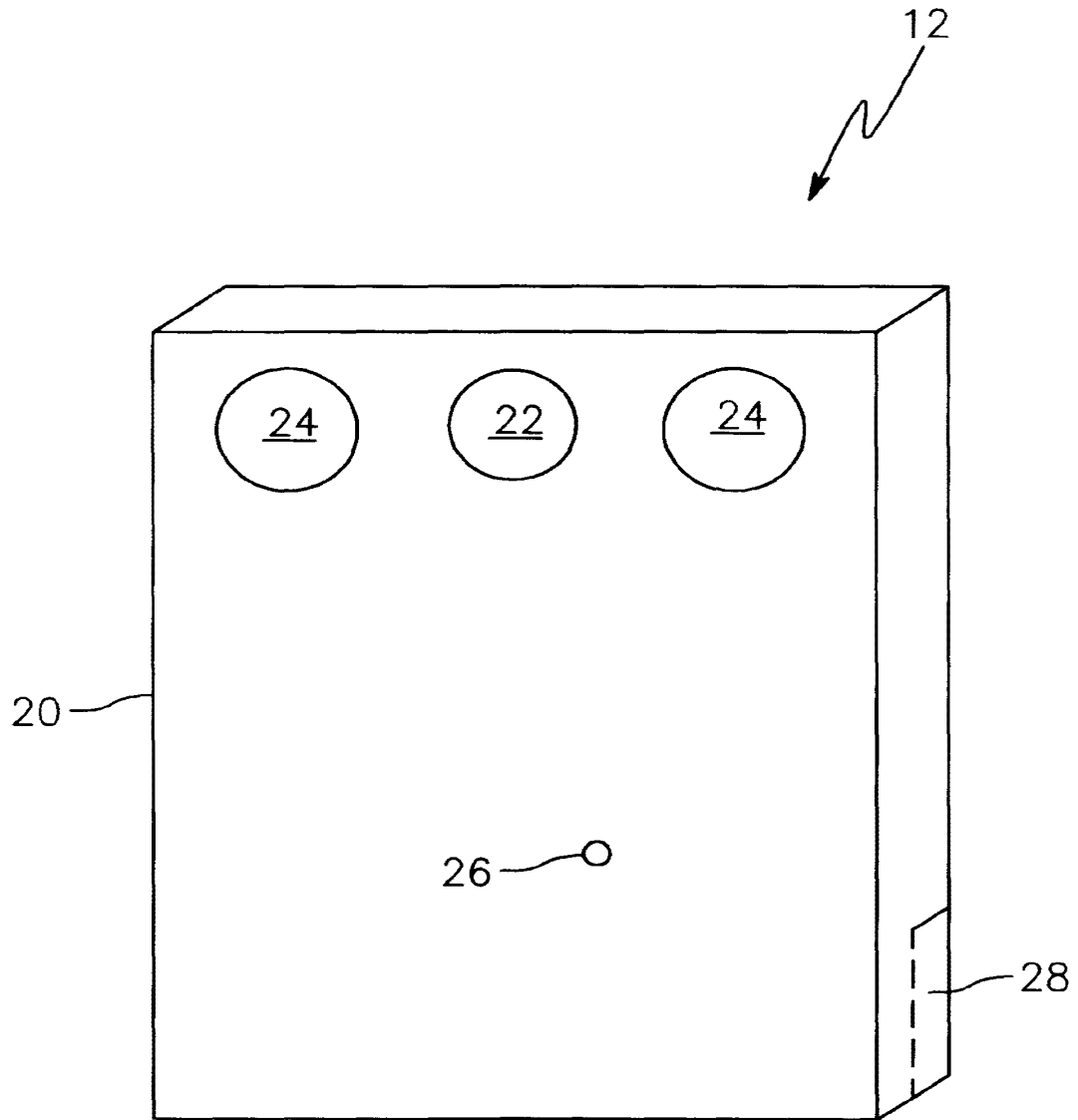

FIG. 3

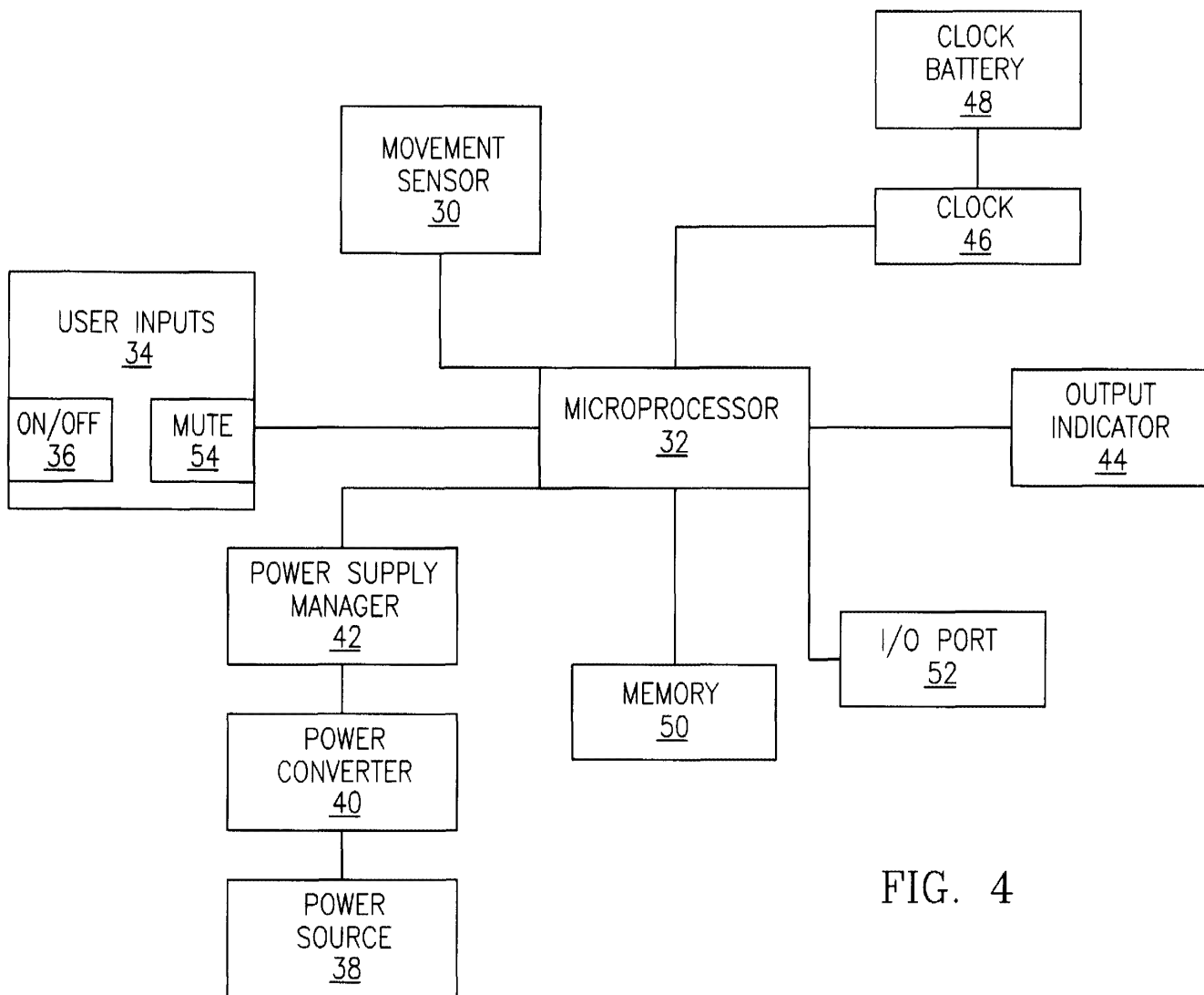

FIG. 4

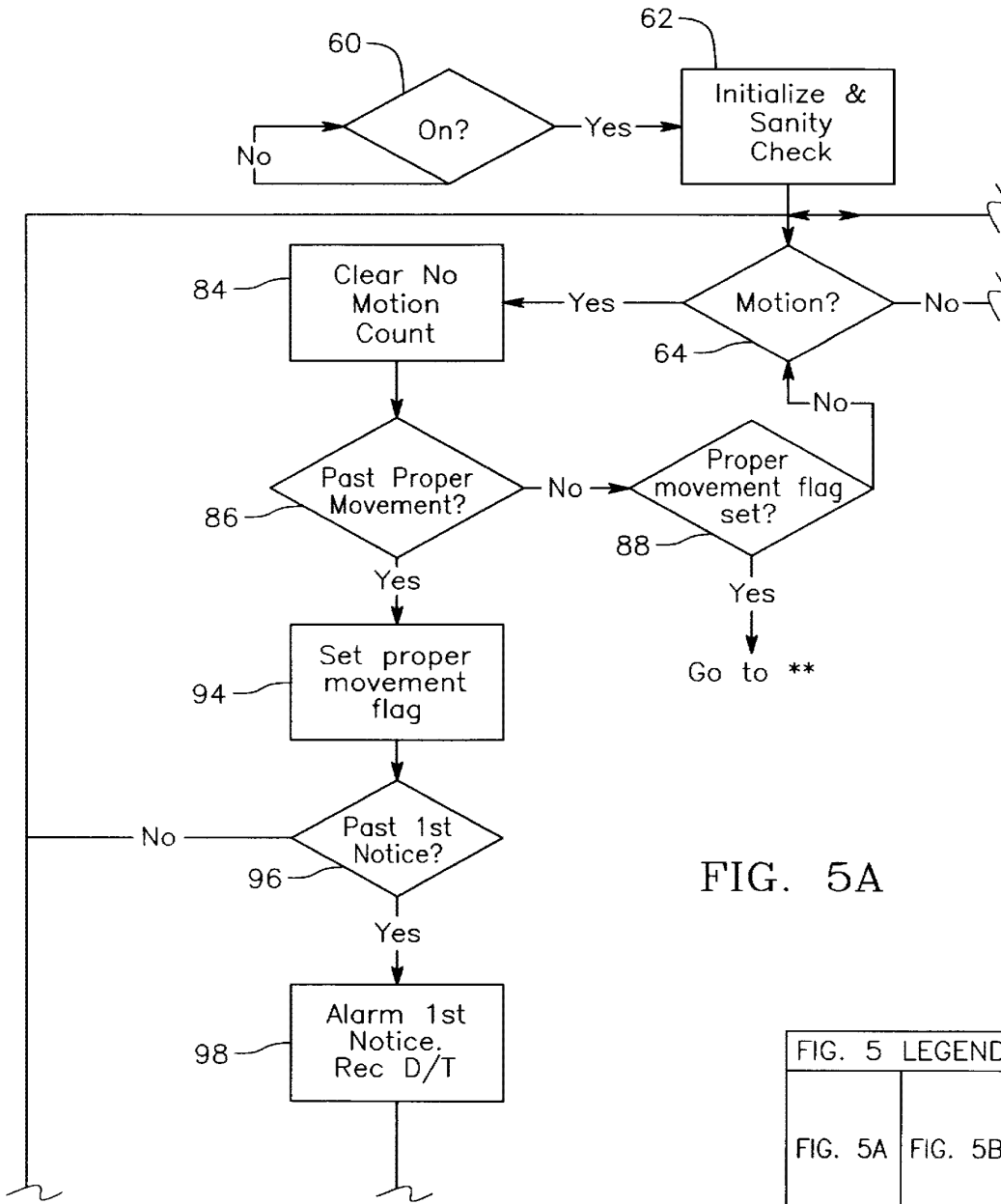

FIG. 5A

FIG. 5 LEGEND	
FIG. 5A	FIG. 5B
FIG. 5C	FIG. 5D

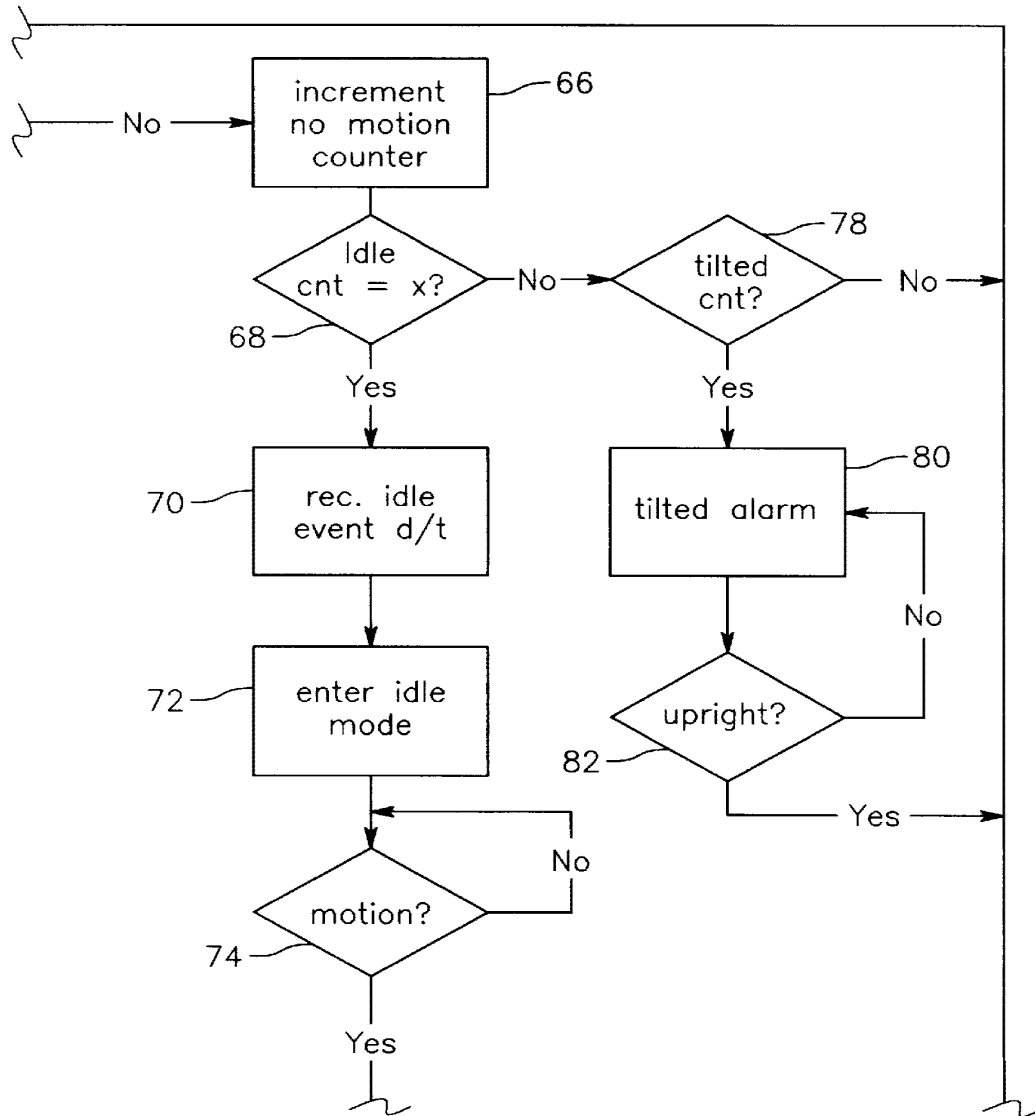

FIG. 5B

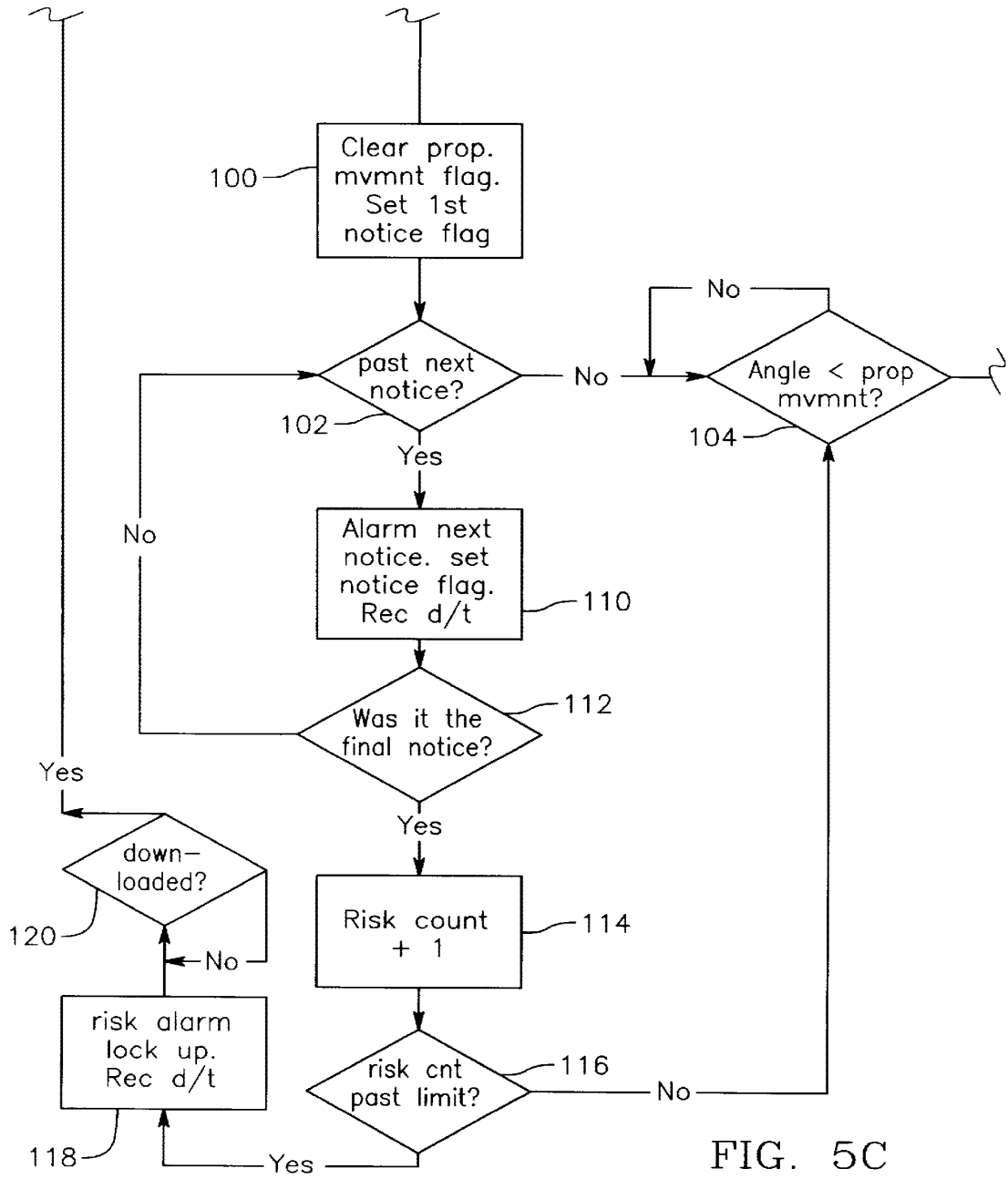

FIG. 5C

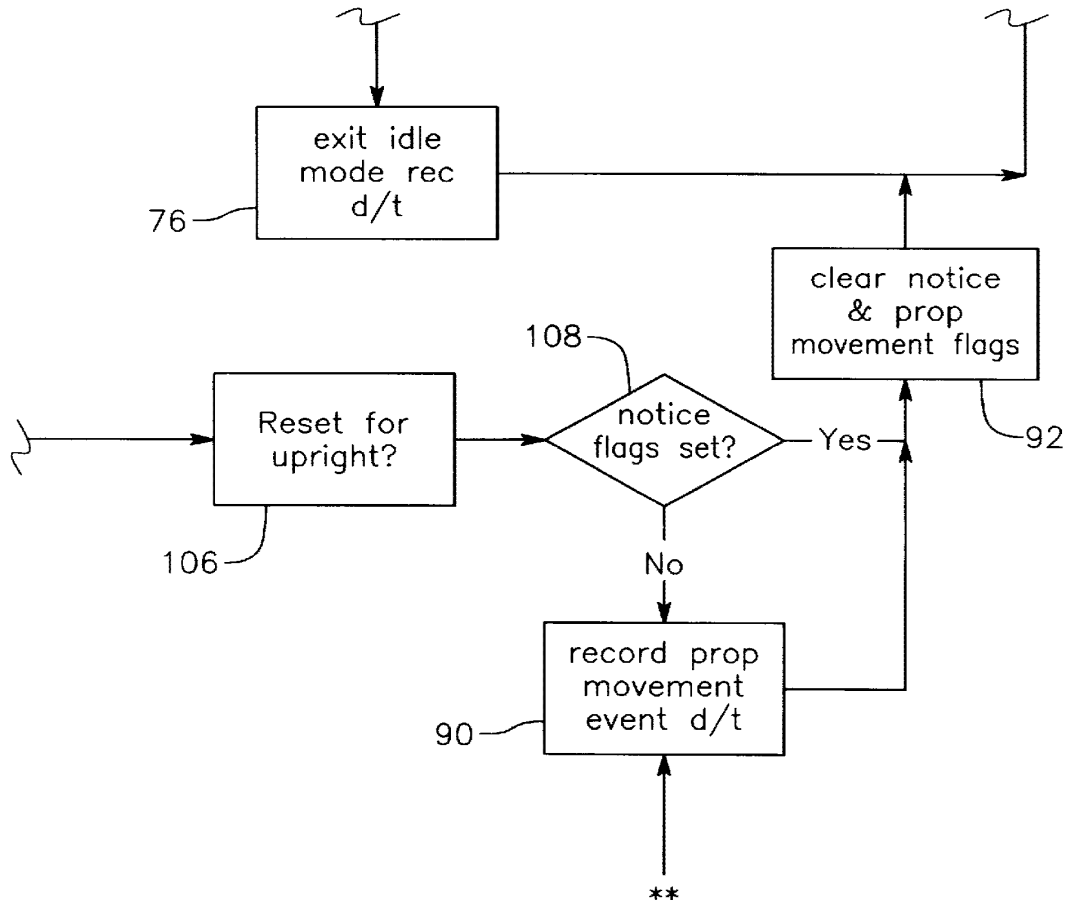

FIG. 5D

1

**TRAINING AND SAFETY DEVICE, SYSTEM
AND METHOD TO AID IN PROPER
MOVEMENT DURING PHYSICAL ACTIVITY**

FIELD OF THE INVENTION

This invention relates to the field of electronic training and safety devices used to monitor human physical activity. More specifically, the invention detects, measures, records, and/or analyzes the time, date, and other data associated with movement of the device and produces meaningful feedback regarding the measured movement.

BACKGROUND

It has long been known that improper physical movement, especially when repeated, can result in injury to a person. This injury may manifest itself in a wide range of symptoms anywhere from sore or bruised muscles to chronic, debilitating loss of movement. In order to study and better understand safe human movement which does not result in injury, a variety of sensing, monitoring, and notification devices have been created. In general, these devices fall under the general category of range of motion (ROM) detectors.

Several such inventions have been patented to measure the range of motion of various joints of the human body for both medical studies and industry applications. Typically, these inventions require that two people simultaneously use the device: the patient/wearer and the operator of the device. The purpose of these devices is to quantitatively determine a range of motion of a human joint in angular degrees as exemplified by U.S. Pat. Nos. 4,665,928; 5,042,505; and 5,373,858. Although the devices disclosed in these patents serve the purposes for which they are intended, they do not warn the device wearer when the wearer is nearing, or has reached, a potentially dangerous angle of movement.

Another class of ROM devices has attempted to provide a warning to the wearer through an audible alarm or flashing light. Typically, these devices activate the alarm when a predetermined angle of flexion or extension has been exceeded in order to try and reduce the number of injuries that can occur as a result of the improper movement. Because of the general weakness of the human spine and back muscles, most of these devices are geared toward detecting improper torso movement while lifting an object. One such invention described in U.S. Pat. No. 5,128,655 uses a mercury switch set at a predetermined angle to trigger a counting mechanism in order to count the number of times the predetermined angle is exceeded during forward bending. Another such device described in U.S. Pat. No. 5,398,697 uses a "T" shaped collimated light beam to detect both forward and lateral bending of the spine. However, these devices are not convenient to operate and serve to merely report rather than analyze the information detected.

Training an individual to make proper movements requires more than just counting the number of times a predetermined angle is surpassed and warning the wearer of the incorrect movement. In order to prevent incorrect movement in hopes of reducing injuries, lost man hours, and workmen's compensation claims, a device must not only be able to record the frequency of improper movements, but also monitor the angular velocity and general tendencies of the wearer with regard to the unsafe movement habits. The angular velocity of any physical action affects the stretching and tautness of the muscle involved in the motion. Thus, information on angular velocity is important to monitoring and analyzing improper movement. Finally, the wearer must

2

also be informed about the tendencies he has regarding his performance of a specific task. In particular, it is helpful to know whether improper movements occur more often in the morning or afternoon.

SUMMARY OF THE INVENTION

According to the present invention, the foregoing and other objects and advantages are attained by a system which may be used to monitor and train a wearer during physical movement. The system employs an electronic device which tracks and monitors an individual's motion through the use of a movement sensor capable of measuring data associated with the wearer's movement. The device also employs a user-programmable microprocessor which receives, interprets, stores and responds to the movement data based on customizable operation parameters, a clock connected to the microprocessor, memory for storing the movement and analysis data, a power source, a port for downloading the data from the device to other computation or storage devices contained within the system, and various input and output components. The downloadable, self-contained device can be worn at various positions along the torso or appendages being monitored depending on the specific physical task being performed. The device also monitors the speed of the movements made while the device is being worn. When a pre-programmed recordable event is recognized, the device records the time and date of the occurrence while providing feedback to the wearer via visual, audible and/or tactile warnings. Periodically, data from the device may be downloaded into an associated computer program which analyzes the data. The program can then format various reports to aid in recognizing and correcting trends in incorrect physical movement.

It is, therefore, an object of this invention to provide a user programmable training and safety device designed to observe and record the direction and frequency of physical movement of the wearer.

It is another object of this invention to provide a system which monitors, records and analyzes the time, date, angle of movement, and angular velocity of physical movement for subsequent interpretation.

It is still another object of this invention to monitor bi-directional movement of the torso about the spine during a lifting movement.

It is yet another object of this invention to detect and monitor a series of angles of movement and to visually and audibly warn the wearer as each angle limit is exceeded during physical movement.

It is yet another object of this invention to provide a device to assist in training an individual in proper posture while executing an identified physical activity.

To achieve these and other objects which will become readily apparent upon a reading of the attached disclosure and appended claims, an improved training and safety device is provided. Additional objects, advantages, and novel features of the invention will be set forth in part in the description which follows, and in part will become apparent to those skilled in the art upon examination of the following, or may be learned by practice of the invention. The objects and advantages of the invention may be realized and attained by means of the instrumentalities and combinations particularly pointed out in the appended claims.

BRIEF DESCRIPTION OF THE DRAWINGS

FIG. 1 is a plan view of the system of the present invention, including the movement measuring device, the download device, and the computer.

3

FIG. 2A is a plan view of a wearer showing a possible location for the movement measuring device in operation.

FIG. 2B is a plan view of a wearer showing another location for the device during operation.

FIG. 2C is a plan view of a wearer showing the location of an alternative embodiment of the device of the present invention.

FIG. 3 is a perspective view of another alternative embodiment of the self-contained movement measuring device of the present invention.

FIG. 4 is a block diagram of the movement measuring device of the present invention.

FIG. 5 is a flowchart of the steps performed by the microprocessor in operating the movement measuring device.

DETAILED DESCRIPTION OF THE PREFERRED EMBODIMENT

Reference is now made to FIG. 1 for a description of a preferred embodiment of the system 10 of the current invention. FIG. 1 shows the movement measuring device 12 positioned above a download device 14 connected to a computer 16. The movement measuring device 12 is designed to be physically attached to a user whose movements are to be monitored by the system 10. The self-contained movement measuring device 12 may be worn by the individual being monitored in a variety of positions based on the specific movement being observed, the particular application in which the device is used, and the convenience of the wearer.

For example, FIG. 2A shows placement of the movement measuring device 12 on the upper torso of an individual 18. Placement of the device 12 at this location will allow monitoring of the flexion and extension of the spinal column during a lifting activity. Similarly, FIG. 2B shows placement of the movement measuring device 12 on the waist or hip of an individual 18. The movement measuring device 12 may be attached via a clip, Velcro, its own belt, or any other means known in the art. Placement of the device 12 on the belt as shown will also permit monitoring of the individual's movement during physical activity. In particular, the device 12 can monitor the forward and backward bending of the spine as well as lateral bending of the spine to aid in correct bending and lifting tasks. The device 12 is also capable of measuring the distance the wearer walks and how fast he walked. FIG. 2C shows another alternative embodiment of the movement measuring device 12. In this version, the movement sensor 13 is separate from the remaining components 15 of the device 12 and is electronically connected to the remaining components 15 via a cable 17 or other commonly used connector. Separating the measurement sensor 13 from the remaining components 15 in this way gives additional flexibility in the use of the device 12. The device 12 operates in the same manner as previously described; however, the movement sensor 13 can be placed anywhere on the individual's body. Again, the specific application will dictate where the movement sensor 13 should be placed. For example, if a monitored activity requires repeated arm movement, the sensor 13 may be placed anywhere along the individual's arm thereby monitoring and recording movement data for the arm.

FIG. 3 shows a more detailed view of the movement measurement device 12 which forms a crucial part of the previously described system along with its respective external components. The internal components of the movement measurement device 12 are housed in a casing 20. This

4

casing 20 serves to protect the internal components and is most commonly made of hard molded plastic, although any suitable material may be substituted. Externally visible on the device 12 is at least one visual indicator 22 which is activated by the device 12 when appropriate. In one preferred embodiment, the visual indicator 22 is a bi-colored light emitting diode (LED) which is activated to notify the wearer when a predetermined angle of motion has been exceeded. Through different colors and blinking patterns, the visual indicator 22 signals many different conditions sensed by the device 12 including when the device 12 is turned on or off, when each of various angle limits is exceeded, and when downloading movement data recorded by the device 12. Alternatively, the visual indicator 22 may be a liquid crystal display or any other display device on which a variety of movement information may be shown. The movement measuring device 12 also contains user inputs 24. In the preferred embodiment, one user input 24 is an ON/OFF switch for controlling the operation of the device 12. Another user input 24 on the device 12 is a MUTE button which permits the wearer of the device to turn off any audible indicators. Typically, once an angle limit has been exceeded, the wearer will be notified through the illumination of a visual indicator, the sounding of an audible alarm, vibration of the device 12, or a combination thereof. In the case of an audible alarm, the MUTE button 24 may be used to turn off the alarm. Any sounds emitted by the device 12 are created by a speaker (not shown) behind the speaker cover 26 located in the external casing 20. Finally, the casing 20 contains a removable battery cover 28 over an externally accessible battery compartment (not shown) which allows the operator of the device 12 to replace the internal power source. In the preferred embodiment this power source is a 1.5 volt battery.

Reference is now made to a block diagram in FIG. 4 which shows the major internal components of the movement measuring device 12 and their interconnections. The device 12 includes a movement sensor 30 which detects movement and measures associated data such as angle, speed, and distance. The movement sensor 30 generates signals corresponding to the measurement data collected. In a preferred embodiment, the movement sensor 30 is an accelerometer which is capable of detecting angles of movement in multiple planes as well as the velocity at which the movement occurs. Alternatively, multiple accelerometers, each capable of measuring angles of movement in only one plane, may be oriented within the device 12 so that movement in multiple planes may be detected. Although many accelerometers are available on the market, the preferred embodiment uses Part No. AD22217 manufactured by Analog Devices of Norwood, Mass. This component is a low G, multi-axis accelerometer. The movement sensor 30 is electronically connected to a microprocessor 32 which receives the signals generated by the movement sensor 30 for analysis and subsequent processing. The microprocessor 32 not only analyzes and responds to the movement data signals from the sensor 30, but also controls the actions of all of the electronic components of the device 12. In a preferred embodiment, the microprocessor 32 is a Motorola MC68HC705C8AFN. It should be noted, however, that other low power, programmable microprocessors may be suitable. The microprocessor 32 constantly monitors the user inputs 34 and acts accordingly. For example, if the device is turned off, the microprocessor 32 monitors the ON/OFF user input 36 to detect when the device 12 is turned back on. Once an "ON" condition is detected, the microprocessor 32 powers up and runs its internal program. The

internal program may be stored within read-only memory located in the microprocessor itself or in memory (not shown) located outside the microprocessor 32.

The components of the device 12 receive power from a power source 38. In a preferred embodiment the power source 38 is a 1.5 volt DC battery; however, other power sources, including alternating current, may be used. The power source 38 is connected to a power converter 40 if DC-DC or AC-DC conversion is required. In one embodiment the power converter 40 converts the 1.5 volt DC power supply from the battery to 3.3 volts DC for use with the other electronic components of the device 12.

Also connected between the power source 38 and the microprocessor 32 is a conventional power supply manager 42 such as part number ADM706TAR from Analog Devices. The power supply manager 42 performs several functions. If a low battery condition exists, the power supply manager 42 reports the problem to the microprocessor 32 so that the microprocessor 32 may indicate the condition to the user through one or more output indicators 44. The output indicators 44 consist of any combination of audible, visual, or tactile indicators for communicating with the wearer of the device. Audible indicators range from a single pitched tone to voice-synthesized messages in English or any foreign language. Visual indicators which could be used include single, monochromatic LEDs, multiple colored lights, and/or liquid crystal displays. The tactile indicator used in a preferred embodiment is a conventional vibrator mechanism which can be detected by the wearer. The power supply manager 42 also regulates the activity of the power converter 40 to insure that the proper voltage is constantly supplied to the device components.

The microprocessor 32 is connected to a clock 46 which is used as an internal clock for coordinating the functioning of the microprocessor 32. The clock 46 also serves as a real time clock to provide date and time information to the microprocessor 32. The clock 46 may have its own clock battery 48 or may receive power directly from power source 38.

The microprocessor 32 constantly monitors the movement data received from the movement sensor 30. The microprocessor 32 analyzes the movement data received from the sensor 30 and, based on its internal programming, responds to the data. If a recordable event occurs, the microprocessor 32 retrieves the date/time stamp from the clock 46 and records the event information along with the date/time stamp in memory 50. In a preferred embodiment, the memory is electrically erasable programmable read-only memory (EEPROM) so that, in the event the device should lose power, the information recorded in memory 50 will not be lost. The device also contains an input/output (I/O) port 52 which is connected to the microprocessor 32. The I/O port 52 is used to receive and transmit data collected by the device 12 between the microprocessor 32 and an external computer (not shown). In a preferred embodiment, the I/O port 52 is a serial port which includes an RS232 voltage level converter download board. Movement data stored in memory 50 can be sent through the I/O port 52 to a download device. In addition, user-programmable configuration information can be entered by a user via the external computer and uploaded through the I/O port 52 for use by microprocessor 32. The configuration information can encompass an array of information including, but not limited to, a series of notice levels corresponding to increasing angles of movement, an event threshold, a reset range for tilt determination, and a time period for entering idle mode. Once the device 12 is operating, the microprocessor 32

constantly checks to see if the angle movement information received from the movement sensor 30 indicates that the wearer has exceeded any of the pre-set notice levels. Depending on which notice level has been exceeded, the microprocessor 32 will cause the device 12 to react; i.e., by sounding an alarm. In addition, the microprocessor 32 will obtain the date/time stamp from the clock 46 and store that information along with the notice level that was exceeded into memory 50 for later analysis and reporting. Whenever an alarm is activated by the microprocessor 32, the MUTE control switch 54 may be used to deactivate the alarm; however, the corresponding movement data associated with the activation of the alarm is still recorded in memory 50. Furthermore, the date and time the MUTE control switch 54 was activated is also recorded by the device 12.

A significant feature of the device 12 of the present invention is that it gives instant information to the wearer at the moment of incorrect movement and also records the information for future reference and analysis. The device 12 monitors a wide variety of "events" and records each event with a date/time stamp. Many different types of "events" may be defined to be monitored by the device 12. As previously stated, any movement which surpasses any identified angle limit of movement (based on the specific physical task being accomplished and the range of motion needed to execute the task properly) is a standard recordable event. In addition, the device will record when no discernable movement has occurred for a predetermined amount of time (idle function), when the wearer has pressed the MUTE switch in response to an alarm (MUTE function), when the wearer's speed of movement exceeds a predefined speed (quickness function), when the device is turned on or off, when a low battery warning has been issued, when the battery is changed, when the device has been tampered with (such as removing the battery before a low battery condition has been detected), when the device is tilted outside of a specified range for a designated period of time, and when the device has measured a predetermined maximum number of particular angle limits reached. These functions are further described hereinbelow.

Whenever an incorrect user movement is sensed by the device 12, the angular limit notice as programmed by the user is given only once. Before the device 12 can reset itself to be able to give that same angle notice on the next incorrect movement, the device 12 must return to a predetermined position (usually the upright position). If the device 12 is maintained outside of its predefined reset range for a designated period of time after an angle limit has been exceeded, a "tilt" event will be recorded and an alarm may be activated. When this situation occurs, the device 12 must be returned to its defined reset position, or the MUTE button must be pressed. The device 12 is also programmed to automatically enter a power saving mode when no motion has been detected for a given amount of time. This "idle" function event is recorded by the microprocessor 32 to indicate that the device is either not being worn or is not being used properly. The device 12 maintains the minimum amount of operating power required to detect the next movement so that, once movement is detected, the device 12 exits the idle mode and records the date and time when the exit occurred.

The device 12 will record any attempted tampering. In a preferred embodiment, this event occurs when the battery is removed before a low battery condition is detected by the device. The device 12 will also inform the wearer when the battery is low. In the preferred embodiment, the device 12 has two batteries, a battery which operates the device 12 and

an internal time clock battery. The internal clock battery powers the time clock 46 and aids in other operations of the device 12 when the voltage drops on the device battery. The microprocessor 32 and memory 50 do not lose information when battery power is lost from either battery.

As previously mentioned, the device 12 is completely user programmable via an external computer. These user programmed operation parameters are uploaded to the microprocessor 32 through the download device (not shown). The user may program the microprocessor 32 with an array of functions for the device 12 to perform. Primary among these is the ability to change the angular levels at which notices will be generated in order to fulfill particular application needs. In this way, the user may choose the angular positions at which he wants to be warned when they are exceeded. In the preferred device, up to three angle limits may be monitored by the device; however, any number of angles may be tracked depending upon the application. Each angle limit can be degree specific or extend over a range of degrees. When a range is used, the user specifies the starting and incremental values in degrees. Thus, an angle limit may be set to occur every five degrees beginning with an initial angle limit value. The movement sensor 30 used in the preferred embodiment can measure angles to within plus or minus 0.5° and as often as 1000 times a second. The most common use for the angle range limits is when the device 12 is worn on the hip since angle measurements cannot be made as accurately there. In contrast, when the device 12 is worn on the upper torso, results can be measured more accurately and the device 12 can be set to measure each degree of movement.

As mentioned above, once a wearer of the device 12 exceeds the first defined angle limit, a notice for that limit is given to the wearer. The notice may be a combination of a visual warning, a tactile warning, and/or an audible warning. The microprocessor 32 also stores the specific angle limit which was exceeded along with the date/time stamp. Upon exceeding the second defined angle, the wearer is issued a second notice which may be the same as or different from the first notice. These different notice characteristics may include a change in pitch for audible alarms, a difference in duration for tactile alarms, and/or a blinking, different colored, or other visual warning.

The "quickness" function of the device 12 measures the speed of an associated physical movement made by the wearer and was developed to address the following problem. In essence, the warning notice due to exceeding a first angle may be overridden by the warning notice for a second angle, thus appearing to give only the second notice. The device 12 may be programmed to recognize when this occurs and to indicate that the associated physical activity was performed by the wearer with excessive speed. If so programmed, the device 12 will record both notices, and the microprocessor 32 will record a quickness violation for further analysis and reporting by the computer. The device 12 may also include an event threshold function in its programming. This feature allows the user of the device 12 who has access to the download capabilities and the analysis software hereinafter described to determine a maximum number of incorrect movements ("events") allowed in a predetermined time period by event type. In addition, the user may program a certain response, such as shutting down the device 12 entirely, emitting a special alarm, and/or recording the date and time each event threshold was met. In a preferred embodiment, if the device 12 is programmed for shut down upon reaching the event threshold, the device 12 will require downloading to the computer 16 and being reset before it

can be operated again. This feature serves to alert the responsible party of a potential problem that must be dealt with immediately via retraining or any other means the responsible party deems necessary.

The device 12 also has additional functions and capabilities. Each unit can be assigned to a specific individual, patient or employee and later reassigned to a different person through the use of specific identification numbers. In a preferred embodiment, the device 12 requires a download of all movement data stored in memory under a previous identification number before it can be reassigned. Further, the download information along with the specific user identification number can be downloaded to the computer 16 only once in order to avoid duplicate records.

As generally described above, the system and device 12 of the present invention have practical application in a number of situations. They may be used in medical applications requiring the monitoring of physical movement. Among such applications is physical therapy which may be conducted either by the patient in the patient's home or by medical professionals in a medical environment. More significantly, the device and system have application in an industrial setting, particularly manufacturing, where workers are required to perform repetitive manual tasks. Supervising employers can use the device and system to insure that employees are performing their tasks properly while minimizing the risk of employee injury.

By virtue of the sophisticated nature of the microprocessor 32, the device 12 can fulfill these additional business, industry and medical needs. Furthermore, wireless capabilities may be added to the device 12 to allow downloading of information from the device 12 to a computer 16 without the need for cables or docking stations. In yet another embodiment, the radio frequency capability may allow the user to wear minimal hardware (consisting primarily of the movement sensor) on the body while transmitting the details of each physical movement to a remote microprocessor 32 for analysis and storage.

Once the data from the device 12 has been downloaded to the computer 16, software running on the computer 16 is used to interpret the data and produce a number of reports and histories. This history information may include, but is not limited to, the dates and times when the device 12 was turned on and off; the number, with dates and times, of each notice given along with the type of notice; the number, date and time the device 12 reached an event threshold; when, how long, and how many times the device 12 powered down; the date and time the device 12 was muted; the date and time when the battery was changed; the date and time when the battery was tampered with; and the last time the device 12 was downloaded. Any of the above-mentioned predefined reports may be generated; in addition, the user may program additional reports and histories specific to the application to be monitored.

FIG. 5 is a flowchart of the steps executed by the microprocessor 32 in the movement measurement device 12 to recognize and record movement data. Referring to FIG. 5, when the device 12 is off, the microprocessor 32 constantly checks for a change in the ON/OFF state 60 by polling the ON/OFF switch to see if it has been switched to the ON position. Once the microprocessor 32 detects that the device 12 has been turned on, the microprocessor 32 conducts some basic initialization and housekeeping functions 62. This may include checking memory to ensure angle limits have been entered, verifying that angle limits are increasing in value (i.e., the second angle limit is not smaller than the first), and

initializing internal program parameters. Then the microprocessor 32 checks to see whether any motion has been detected 64 by the movement sensor 30. If no motion has been detected, the microprocessor 32 will increment a "no-motion" counter 66. The microprocessor 32 then checks 5 whether the no-motion counter has reached a predefined number of cycles indicating that the device should power down. If the requisite number of cycles indicating idle mode have elapsed, the microprocessor records the idle event (along with the date and time stamp) in memory, and the device enters the idle mode 72. Once in idle mode, the microprocessor repeatedly checks for motion 72. As long as no motion occurs, the device remains in idle mode. Once motion is detected, the microprocessor records an event that the device has exited idle mode (with the corresponding date and time) 76. The microprocessor then returns to step 64 where it again attempts to detect motion. If the no-motion counter has not reached the preset limit corresponding to idle mode, the microprocessor will check to see whether the device has remained outside of its predefined reset range for a designated amount of time 78. If not, the microprocessor reexecutes the cycle for detecting motion 64. If, however, the microprocessor recognizes a tilt event, an alarm corresponding to a tilt event is activated 80. Once the microprocessor has recognized a tilt event, it repeatedly checks 25 whether the device has been moved back within its reset range 82. If it has not, the microprocessor continues to activate the tilt alarm. Once the device has been returned to within its reset range, the microprocessor checks again for motion 64.

Once the microprocessor detects motion in step 64, the first thing it does is clear the no-motion counter 84. The microprocessor then checks to see whether it has recorded a "proper movement" in the past 86. If no proper movement has occurred, the microprocessor checks whether the proper movement flag has been set 88. If the proper movement flag has not been set, the microprocessor returns to its initial motion checking step 64. If, however, the proper movement flag has been set, the microprocessor will record the occurrence of a proper movement event along with the date/time stamp 90. The microprocessor then clears all notice and the proper movement flags in step 92 and returns to the motion detection step 64. If, on the other hand, the microprocessor has detected a prior proper movement 86, it so indicates by setting the proper movement 94. The microprocessor then checks whether the first angle limit has been exceeded 96. If this first limit has not yet been exceeded, the microprocessor returns to the motion detection step 64. If the first angle limit has been exceeded, the microprocessor activates the appropriate alarm and records the event along with the date and time 98. The microprocessor then clears the proper movement flag and sets the first angle notice flag 100. The microprocessor then checks whether the device has moved beyond the next angle limit 102. If not, the microprocessor checks whether the angle is less than that required to constitute a proper movement 104. If not, then the microprocessor continues to check whether the angle of movement is less than a proper movement angle. If the angle is less than that constituting a proper movement, the microprocessor triggers a reset flag indicating that the device has been reset 106. After reset, the microprocessor checks whether any of the angle limits have been exceeded thereby setting any of the notice flags 108. If any notice flags have been set, the microprocessor will perform step 92 to clear all of the notice flags and reset the proper movement flag. If none of the notice flags have been set before the device was reset, the microprocessor will perform step 90 to record a

proper movement event along with the date and time. It then continues processing at step 92.

Once the angle of movement detected exceeds the next angle limit, the microprocessor will record the corresponding notice event along with the date and time and activate the appropriate notice alarm in step 110. The microprocessor then checks if the last movement exceeded the final angle limit at step 112. If not, then the process returns to step 102 to check for movement beyond the next angle limit. If the final notice event was detected, then the microprocessor will increment the event threshold counter by one at step 114 if this option has been selected by the user. Next, the microprocessor will check to see whether the event threshold limit has been reached 116. If not, the microprocessor will perform step 104 until the device is reset due to the movement angle being less than that required for a proper movement. If the event threshold has been reached, then the microprocessor will record the event threshold, activate the associated alarm, and shut down the device 118. The microprocessor will prevent the device from operating any further until its information has been downloaded 120. Once the stored data has been downloaded, the microprocessor returns to its initial motion detection step 64 for further operation.

As previously alluded to herein, the device and system of the present invention can be used in a wide number of different applications requiring monitoring and feedback of physical movement. In particular, the device and system have various medical applications including rehabilitation and physical therapy associated with an injured patient. The movement sensor is simply attached to the appropriate body part requiring monitoring, and data collection is then commenced. Besides providing the operator with instant feedback regarding the physical movement being monitored, a variety of data may be collected from the number of movement repetitions meeting or exceeding a required range to the determination and tracking of maximum range-of-motion mobility of an injured patient for later analysis. While the device and system may be operated by a medical professional in a supervisory capacity, both are simple enough to be used by an individual patient alone with download and analysis by the medical professional at a later time.

The device also has excellent application to the monitoring and analysis of physical labor performed by employees. The devices may be passed out to employees having repetitive physical tasks so that proper safety in performing the tasks, such as lifting, may be practiced. Each device can be assigned to a particular individual for a specified amount of time and programmed to monitor that individual's physical tasks. After the device is turned in, its collected information can be downloaded to the system for reporting and analysis purposes based on specific movement limits and other operational parameters programmed into the device for the particular movement being monitored. Improper movements made by the individual during the time period in question are identified, and the employee can be notified in order to make necessary corrections to the way the task is performed in order to avoid injury resulting from improper movement. The device can be used again later to ensure that the employee continues to exercise the movement guidelines as previously instructed.

The device also has application in the area of sports. For example, it may be worn by a golfer in order to monitor torso, waist, shoulder and arm movement during various drives and putts. The data collected by the device may then be used as a tool to aid in the analysis and improvement of the individual's stroke technique. Use of the device is not

11

limited to golf but may be used for any number of sports, including football, baseball, basketball, or tennis. And, due to the unique programmability of the device, it has more than one application within any single sport. For example, in baseball, the device and system may be used to improve technique associated with hitting or with throwing.

Still other objects and advantages of the present invention will become readily apparent to those skilled in this art from the detailed description, wherein multiple preferred embodiments of the invention are shown and described, simply by way of illustration of the best mode contemplated by the inventor for carrying out the invention. As will be realized, the invention is capable of other and different embodiments, and its several details are capable of modifications in various obvious respects, all without departing from the invention. Accordingly, the drawings and description are to be regarded as illustrative in nature, and not as restrictive. Variations in the description likely to be conceived of by those skilled in the art still fall within the breadth and scope of the disclosure of the present invention. The primary import of the present invention lies in its compact size, ease of use, and detailed information gathering and reporting features. Its benefits derive from the versatility of its monitoring capabilities as well as the specific applications for which it may be used. Again, it is understood that other applications of the present invention will be apparent to those skilled in the art upon reading the preferred embodiments and consideration of the appended claims.

We claim:

1. A portable, self-contained device for monitoring movement of body parts during physical activity, said device comprising:
 - a movement sensor capable of measuring data associated with unrestrained movement in any direction and generating signals indicative of said movement;
 - a power source;
 - a microprocessor connected to said movement sensor and to said power source, said microprocessor capable of receiving, interpreting, storing and responding to said movement data based on user-defined operational parameters;
 - at least one user input connected to said microprocessor for controlling the operation of said device;
 - a real-time clock connected to said microprocessor;
 - memory for storing said movement data; and
 - an output indicator connected to said microprocessor for signaling the occurrence of user-defined events;
 wherein said movement sensor measures the angle and velocity of said movement.
2. The device of claim 1 further comprising at least one input/output port connected to said microprocessor for downloading said data and uploading said operational parameters to and from a computer.
3. The device of claim 1 wherein said device is compact and weighs less than one pound.
4. The device of claim 1 wherein said movement sensor comprises at least one accelerometer.
5. The device of claim 1 wherein said movement sensor can simultaneously detect real time movement along at least two orthogonal axes.
6. The device of claim 1 wherein said movement sensor is housed separately from said microprocessor.
7. The device of claim 1 wherein said monitored body part movement is torso or limb movement.
8. The device of claim 1 wherein said data measured by said movement sensor includes the distance of said movement.

12

9. The device of claim 1 wherein said output indicator is visual.

10. The device of claim 1 wherein said output indicator is audible.

11. The device of claim 1 wherein said output indicator is tactile.

12. The device of claim 1 wherein said user input is a switch.

13. A system to aid in training and safety during physical activity, said system comprising

- a portable, self-contained movement measuring device, said movement measuring device further comprising
 - a movement sensor capable of measuring data associated with unrestrained movement in any direction and generating signals indicative of said movement;
 - a power source;
 - a microprocessor connected to said power source, said microprocessor capable of receiving, interpreting, storing and responding to said movement data based on user-defined operational parameters;
 - at least one user input connected to said microprocessor for controlling the operation of said device;
 - a real-time clock connected to said microprocessor;
 - memory for storing said movement data;
 - at least one input/output port connected to said microprocessor for downloading said data and uploading said operational parameters; and
 - an output indicator connected to said microprocessor;
 - a computer running a program capable of interpreting and reporting said movement data based on said operational parameters; and
 - a download device electronically connected to said movement measuring device and said computer for transmitting said movement data and operational parameters between said movement measuring device and said computer for analysis, reporting and operation purposes;
- wherein said movement sensor measures the angle and velocity of said movement.

14. The system of claim 13 wherein said computer is a personal computer.

15. The system of claim 13 wherein said computer is connected to a network of other computers.

16. The system of claim 13 wherein said download device is a physical docking station.

17. The system of claim 13 wherein said download device is a wireless device.

18. The system of claim 17 wherein said wireless device uses radio frequency.

19. The system of claim 17 wherein said wireless device uses infrared light.

20. A method to monitor physical movement of a body part comprising the steps of:

- attaching a portable, self-contained movement measuring device to said body part for measuring unrestrained movement in any direction;
- measuring data associated with said physical movement;
- interpreting said physical movement data based on user-defined operational parameters and a real-time clock; and
- storing said data in memory.

21. The method of claim 20 wherein said physical movement data includes velocity data of said movement, angle measurement data taken along at least two orthogonal axes, and related date and time data.

22. The method of claim 21 further comprising the step of defining said parameters for a specific physical movement prior to said interpreting step.

13

23. The method of claim **21** further comprising the step of downloading said data from said movement measuring device to a computer for reporting and analysis purposes.

24. The method of claim **21** wherein said interpreting step comprises teaching an individual how to properly perform said physical movement. 5

25. The method of claim **20** wherein said movement measuring device is an accelerometer.

26. The method of claim **20** further comprising the step of providing real time feedback regarding said movement.

14

27. The method of claim **26** wherein said physical movement is physical labor.

28. The method of claim **26** wherein said physical movement is an exercise related to medical treatment.

29. The method of claim **26** wherein said physical movement is an exercise to improve technique related to an athletic skill.

* * * * *



UNITED STATES PATENT AND TRADEMARK OFFICE

UNITED STATES DEPARTMENT OF COMMERCE
 United States Patent and Trademark Office
 Address: COMMISSIONER FOR PATENTS
 P.O. Box 1450
 Alexandria, Virginia 22313-1450
 www.uspto.gov



Bib Data Sheet

CONFIRMATION NO. 9930

SERIAL NUMBER 90/013,201	FILING OR 371(c) DATE 04/04/2014 RULE	CLASS 434	GROUP ART UNIT 3993	ATTORNEY DOCKET NO. A209779
------------------------------------	---	---------------------	-------------------------------	---------------------------------------

AIA (First Inventor to File): YES

INVENTORS

6059576, Residence Not Provided;
 LOGANTREE LP(OWNER), BOERNE, TX;
 PATENT OWNER, WASHINGTON, DC;

APPLICANTS

6059576, Residence Not Provided;
 LOGANTREE LP(OWNER), BOERNE, TX;
 PATENT OWNER, WASHINGTON, DC;

**** CONTINUING DATA *******

This application is a REX of 08/976,228 11/21/1997 PAT 6059576

**** FOREIGN APPLICATIONS *******

Foreign Priority claimed 35 USC 119 (a-d) conditions met Verified and Acknowledged	<input type="checkbox"/> yes <input type="checkbox"/> no <input type="checkbox"/> yes <input type="checkbox"/> no <input type="checkbox"/> Met after Allowance Examiner's Signature _____ Initials _____	STATE OR COUNTRY	SHEETS DRAWING	TOTAL CLAIMS 29	INDEPENDENT CLAIMS 3
--	--	-------------------------	-----------------------	---------------------------	--------------------------------

ADDRESS

23373

TITLE

TRAINING AND SAFETY DEVICE, SYSTEM AND METHOD TO AID IN PROPER MOVEMENT DURING PHYSICAL ACTIVITY

FILING FEE RECEIVED 12000	FEES: Authority has been given in Paper No. _____ to charge/credit DEPOSIT ACCOUNT No. _____ for following:	<input type="checkbox"/> All Fees <input type="checkbox"/> 1.16 Fees (Filing) <input type="checkbox"/> 1.17 Fees (Processing Ext. of time) <input type="checkbox"/> 1.18 Fees (Issue) <input type="checkbox"/> Other _____ <input type="checkbox"/> Credit
-------------------------------------	---	---