



US005697466A

United States Patent [19]

[11] Patent Number: **5,697,466**

Moroto et al.

[45] Date of Patent: **Dec. 16, 1997**

- [54] **HYBRID VEHICLE**
- [75] Inventors: **Shuzo Moroto; Mutsumi Kawamoto; Kozo Yamaguchi; Shigeo Tuzuki; Yoshinori Miyaishi**, all of Aichi-ken, Japan
- [73] Assignee: **Kabushikikaisha Equos Research**, Japan

4,533,011	8/1985	Heidemeyer et al.	180/65.2
5,117,931	6/1992	Nishida	180/65.2
5,176,213	1/1993	Kawi et al.	180/65.2 X
5,343,970	9/1994	Severinsky	180/65.2

FOREIGN PATENT DOCUMENTS

59-204402 5/1987 Japan .

Primary Examiner—Eric D. Culbreth
Assistant Examiner—Michael Mar
Attorney, Agent, or Firm—Lorusso & Loud

- [21] Appl. No.: **149,806**
- [22] Filed: **Nov. 10, 1993**
- [30] **Foreign Application Priority Data**

Nov. 12, 1992 [JP] Japan 4-302675

[51] Int. Cl.⁶ **B60K 6/02**

[52] U.S. Cl. **180/65.2; 180/65.8; 364/424.026; 364/424.085**

[58] Field of Search 180/65.2, 65.8, 180/178, 179, 65.3, 65.4; 364/424.01, 424.03, 424.026, 424.084, 424.085

[56] References Cited

U.S. PATENT DOCUMENTS

4,305,254	12/1981	Kawakatsu et al.	180/65.2 X
4,313,080	1/1982	Park	180/65.2 X
4,335,429	6/1982	Kawakatsu	180/65.2 X
4,470,476	9/1984	Hunt	180/65.2

[57] ABSTRACT

A hybrid vehicle maintains its travel even if the motor driving system used therein suddenly encounters some problem in operation. The hybrid vehicle has an internal combustion engine and an electric motor with its output connected to an output axle. A clutch is provided to selectively connect the internal combustion engine to the output axle and a hydraulic power transmission is provided between the clutch and the internal combustion engine. A drive power share computer apportions the needed drive power between the engine and the motor. A detector is provided for detecting a malfunction of the motor. A first controller serves to release the clutch when the vehicle is running in a motor drive mode and a second controller effects engagement of the clutch and driving with the engine, even when the vehicle is a motor drive mode, when the detector detects a malfunction of the motor.

22 Claims, 11 Drawing Sheets

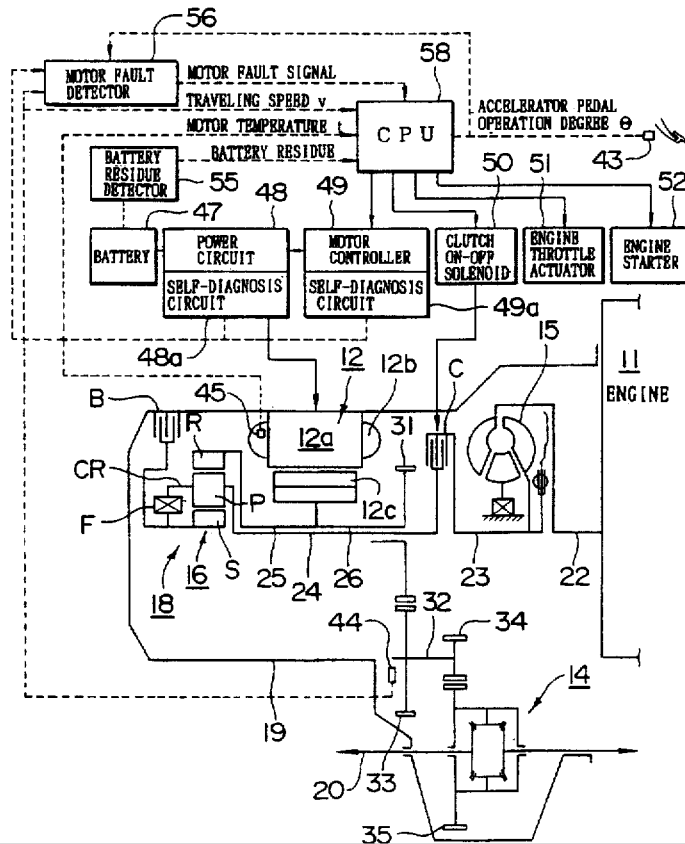

FIG. 1

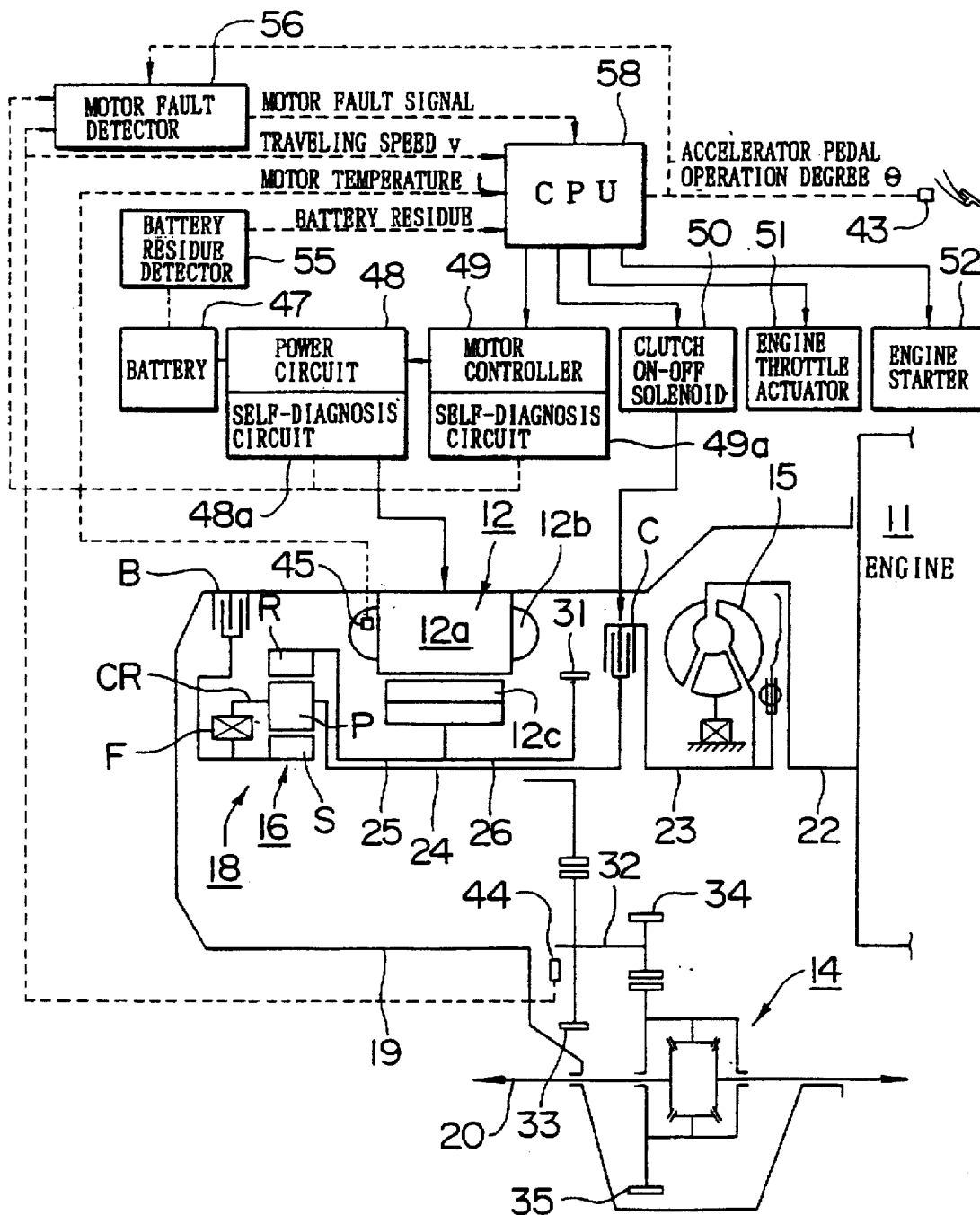

FIG. 2

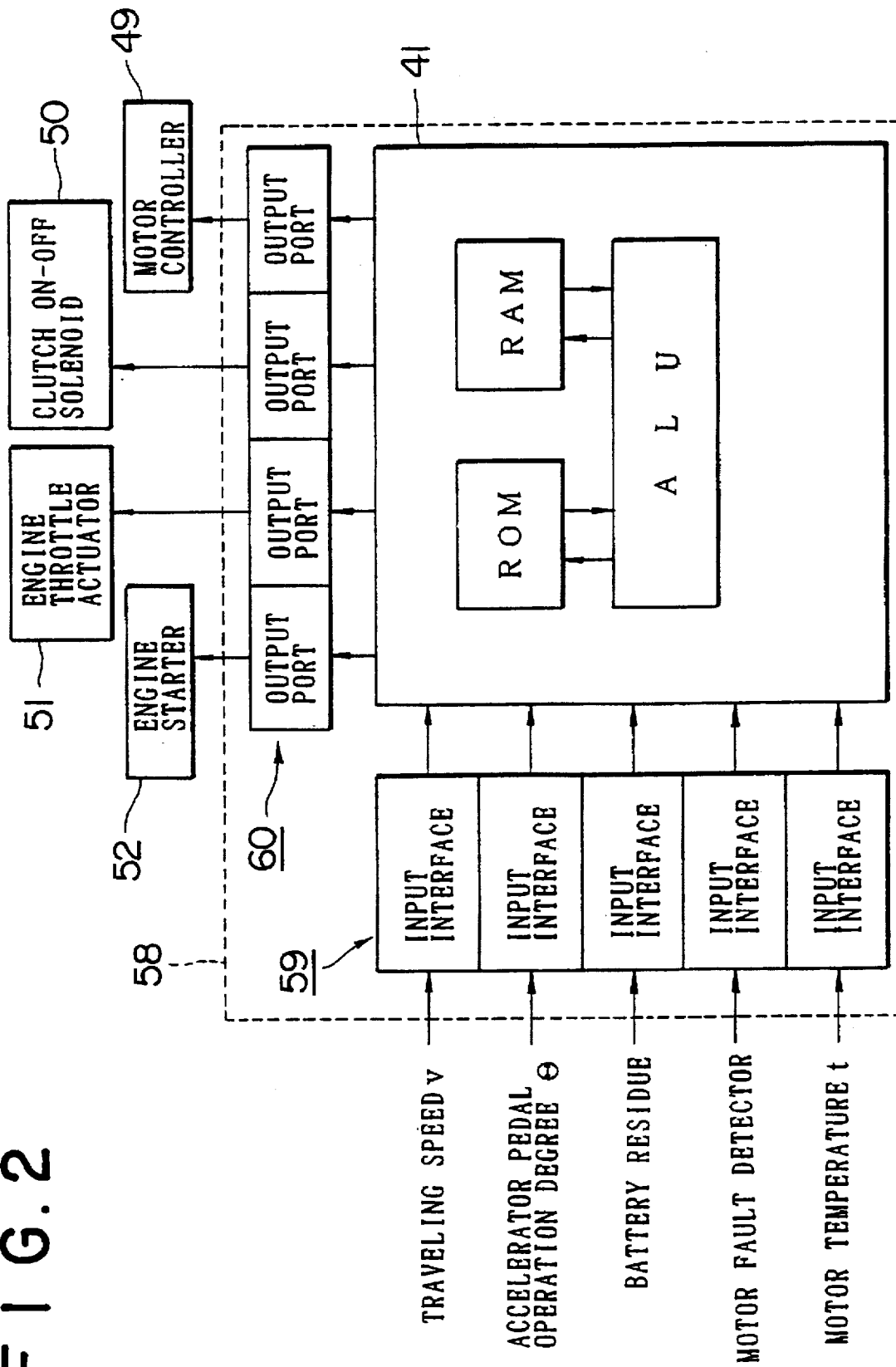

FIG. 3

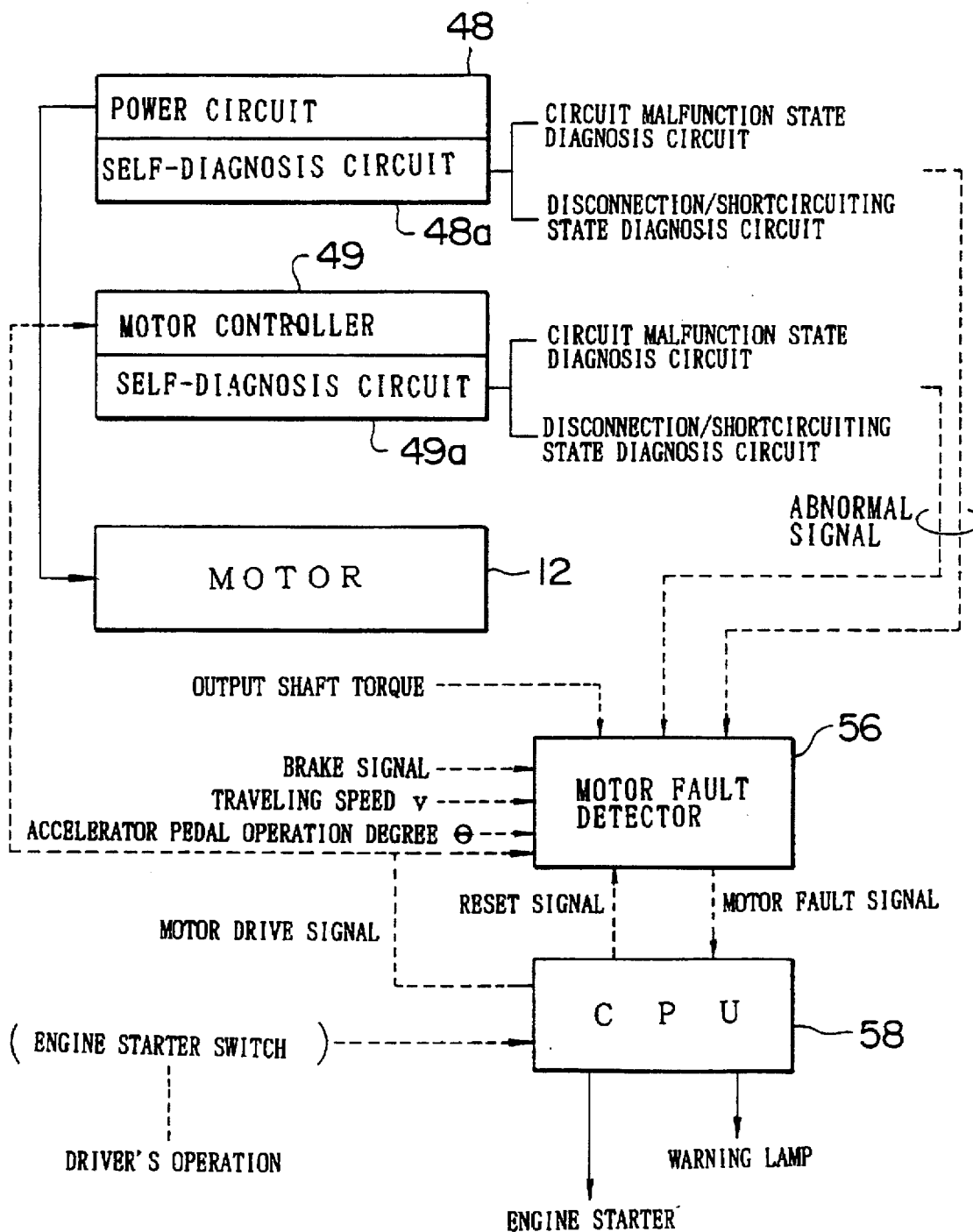

FIG. 4

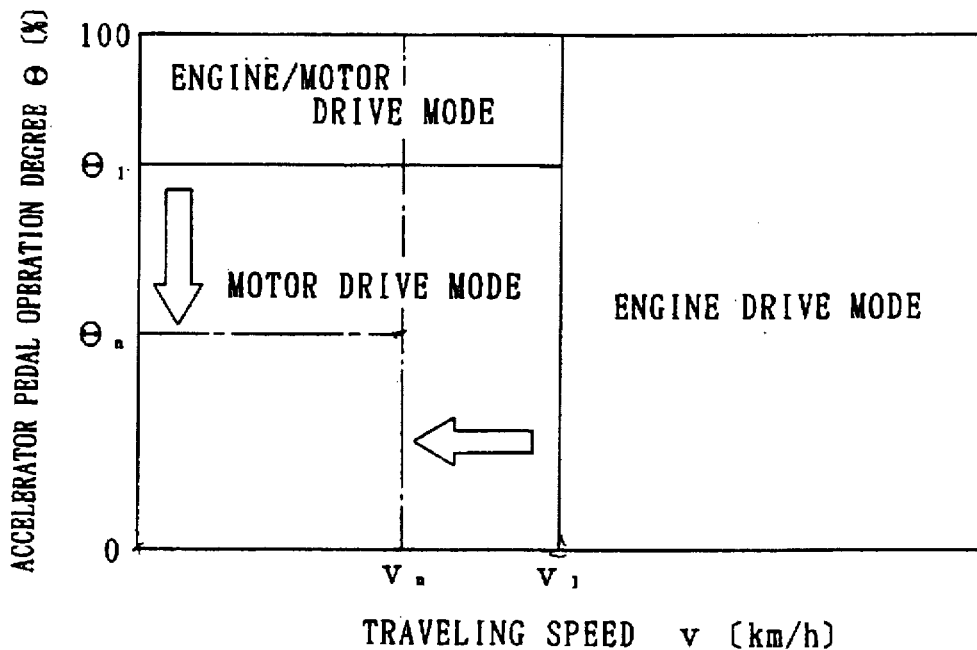
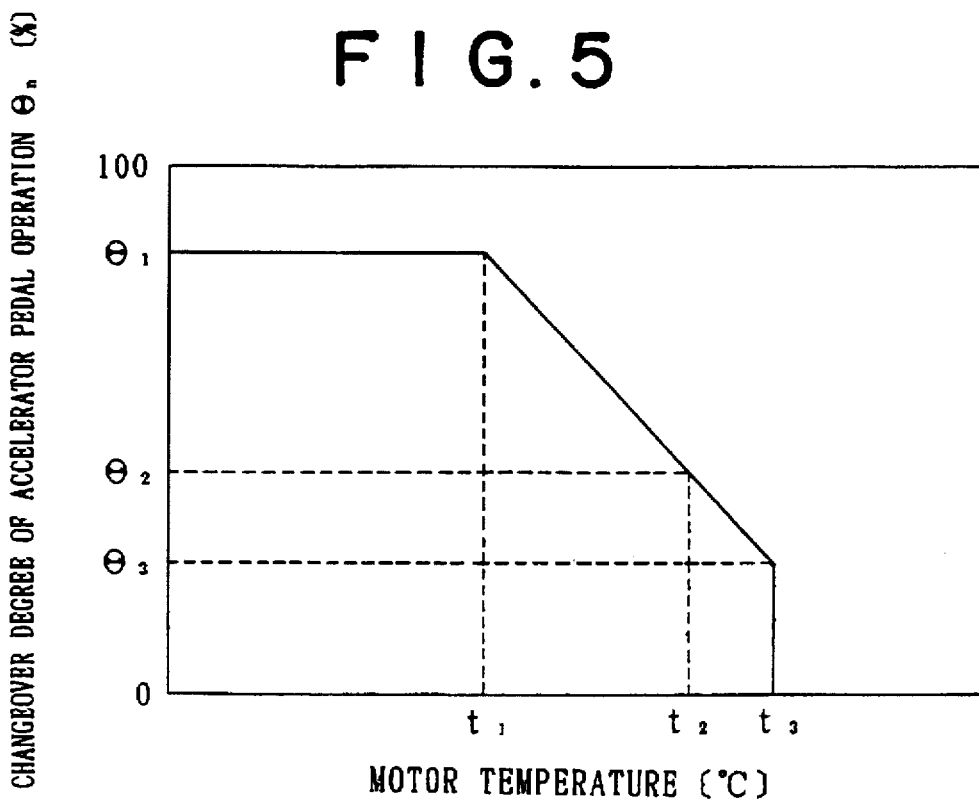

FIG. 5



Explore Litigation Insights

Docket Alarm provides insights to develop a more informed litigation strategy and the peace of mind of knowing you're on top of things.

Real-Time Litigation Alerts



Keep your litigation team up-to-date with **real-time alerts** and advanced team management tools built for the enterprise, all while greatly reducing PACER spend.

Our comprehensive service means we can handle Federal, State, and Administrative courts across the country.

Advanced Docket Research



With over 230 million records, Docket Alarm's cloud-native docket research platform finds what other services can't. Coverage includes Federal, State, plus PTAB, TTAB, ITC and NLRB decisions, all in one place.

Identify arguments that have been successful in the past with full text, pinpoint searching. Link to case law cited within any court document via Fastcase.

Analytics At Your Fingertips



Learn what happened the last time a particular judge, opposing counsel or company faced cases similar to yours.

Advanced out-of-the-box PTAB and TTAB analytics are always at your fingertips.

API

Docket Alarm offers a powerful API (application programming interface) to developers that want to integrate case filings into their apps.

LAW FIRMS

Build custom dashboards for your attorneys and clients with live data direct from the court.

Automate many repetitive legal tasks like conflict checks, document management, and marketing.

FINANCIAL INSTITUTIONS

Litigation and bankruptcy checks for companies and debtors.

E-DISCOVERY AND LEGAL VENDORS

Sync your system to PACER to automate legal marketing.