



US005600313A

# United States Patent [19]

[11] Patent Number: **5,600,313**

**Freedman**

[45] Date of Patent: **Feb. 4, 1997**

[54] **COMPUTER KEYBOARD**

Primary Examiner—Jeffery Hofsass  
Assistant Examiner—Andrew Hill

[76] Inventor: **Lorri Freedman**, 2667 Loretta St.,  
Yorktown Heights, N.Y. 10598

[57] **ABSTRACT**

[21] Appl. No.: **577,112**

A computer keyboard including a keyboard body that has a top side, a bottom side, and a pair of short peripheral walls with a pair of long peripheral walls therebetween. The top side of the keyboard body has a keyboard mechanism located thereon. A wrist pad is positioned on the top side of the keyboard and is perpendicular one of the long peripheral walls. Included are a plurality of keys that are positioned on the keyboard mechanism and comprised of a space bar, function keys and alphabet keys. A pointing stick is positioned from the space bar and between the alphabet keys of the keyboard mechanism. The pointing stick controls all movement of a cursor on a display screen of a computer. Lastly, a pair of mouse buttons are provided and spaced from the space bar on the keyboard mechanism. The pair of mouse buttons form a right button and a left button that functions in accordance with the pointing stick when the user positions the cursor on an icon.

[22] Filed: **Dec. 22, 1995**

[51] Int. Cl.<sup>6</sup> ..... **H03K 17/94**

[52] U.S. Cl. .... **341/22; 341/23; 400/489**

[58] Field of Search ..... 341/22, 23; 345/161,  
345/168; 364/709.01, 709.12; 400/472,  
479, 486, 489, 715

[56] **References Cited**

**U.S. PATENT DOCUMENTS**

5,438,331 8/1995 Gilligan ..... 345/168  
5,486,846 1/1996 Comer et al. .... 345/168

**FOREIGN PATENT DOCUMENTS**

94-24865 10/1994 WIPO ..... 341/22

**1 Claim, 3 Drawing Sheets**

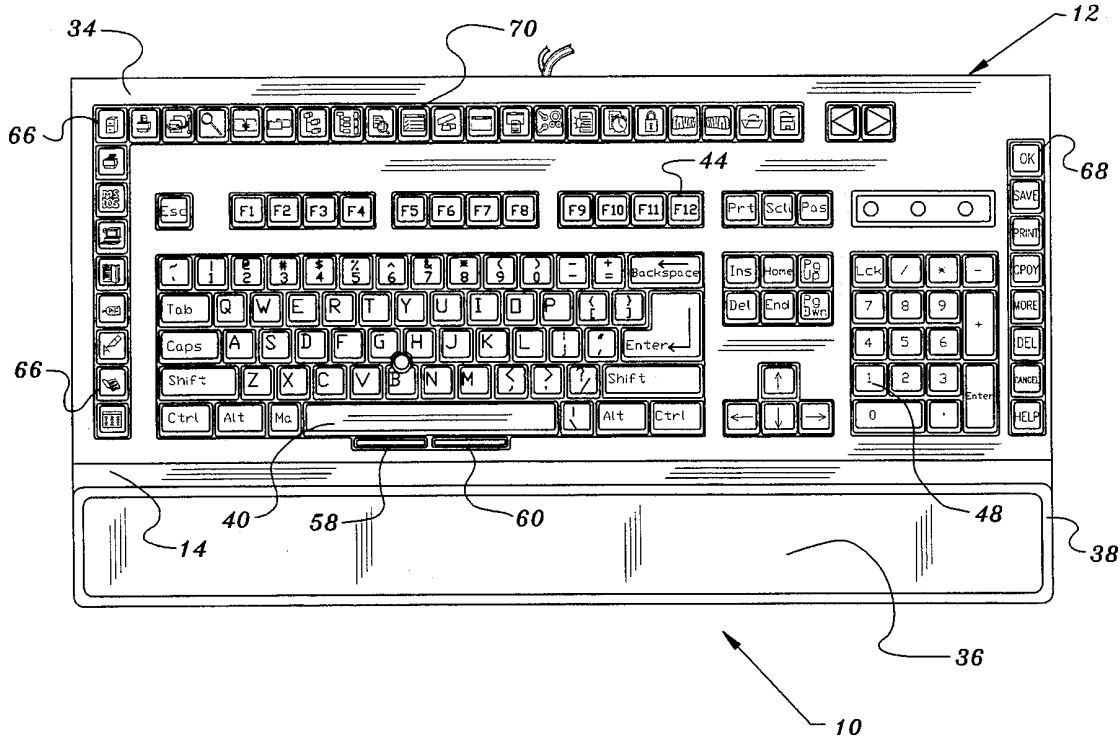

RPX Exhibit 1139  
RPX v. DAF

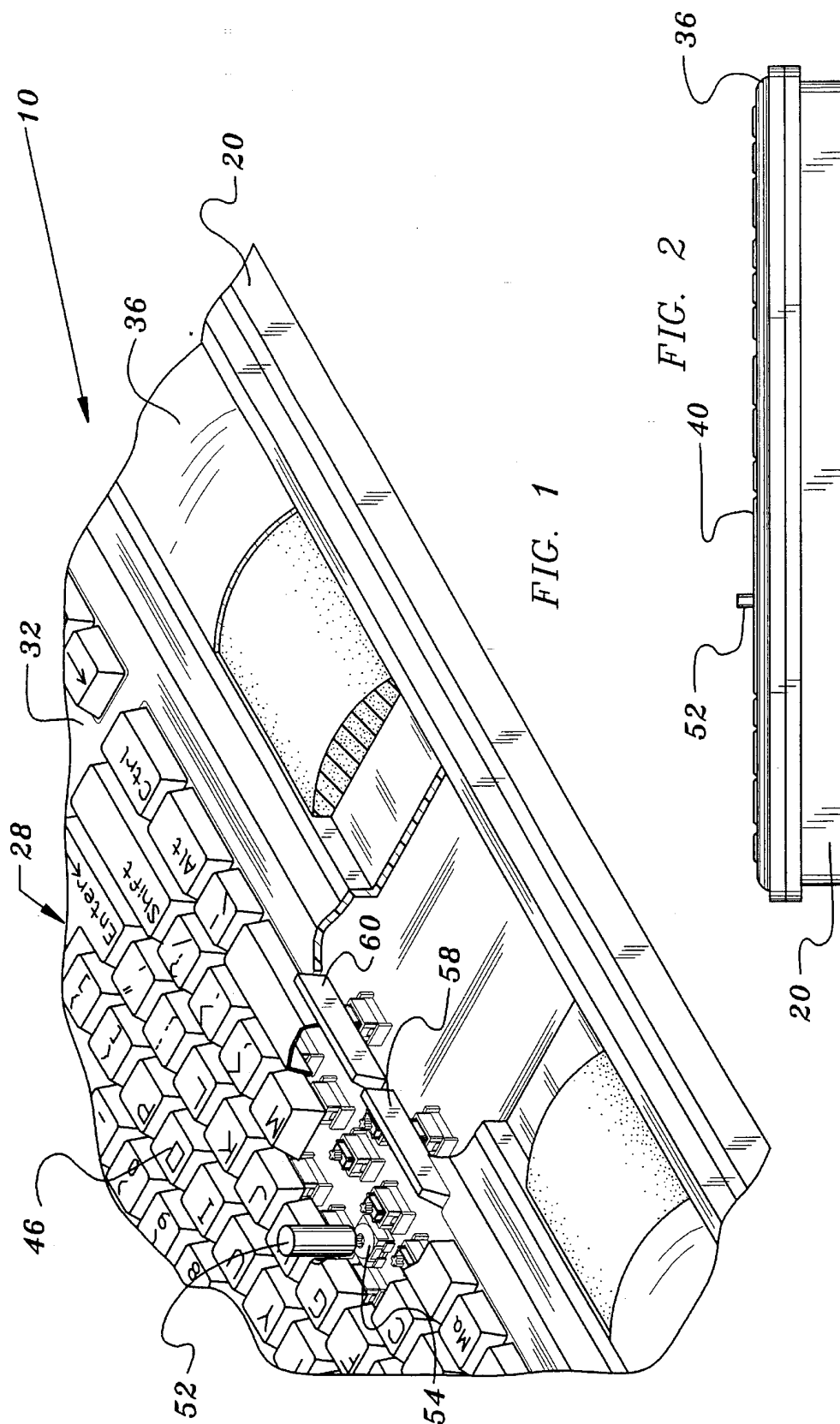

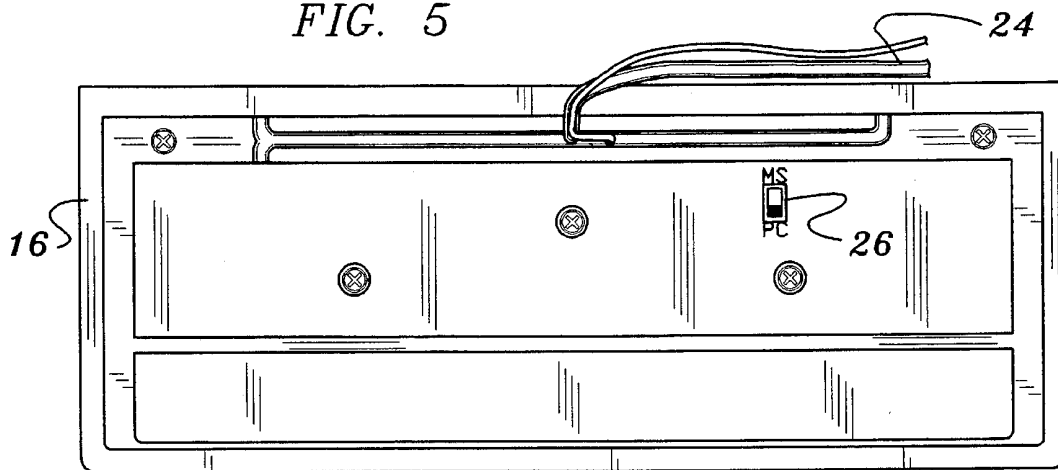
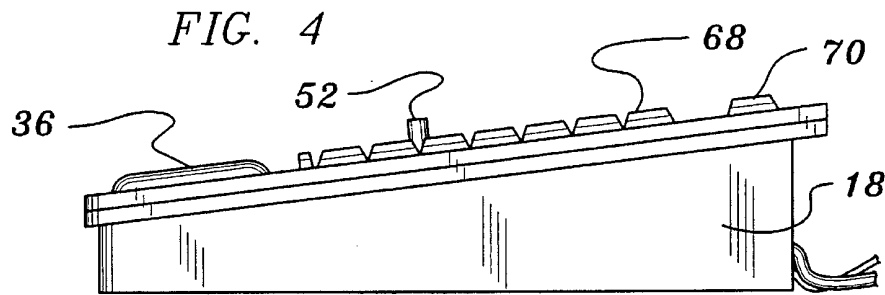
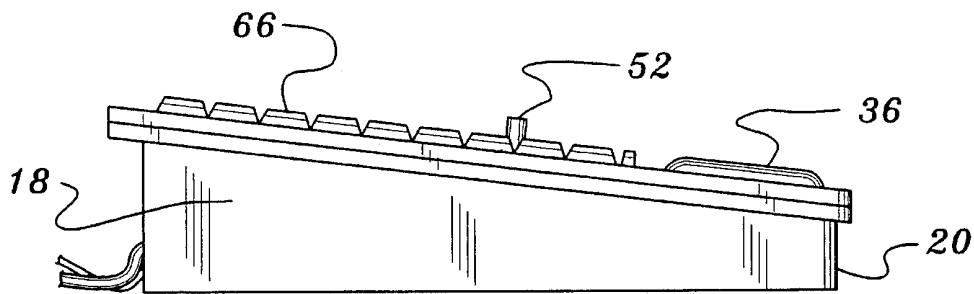
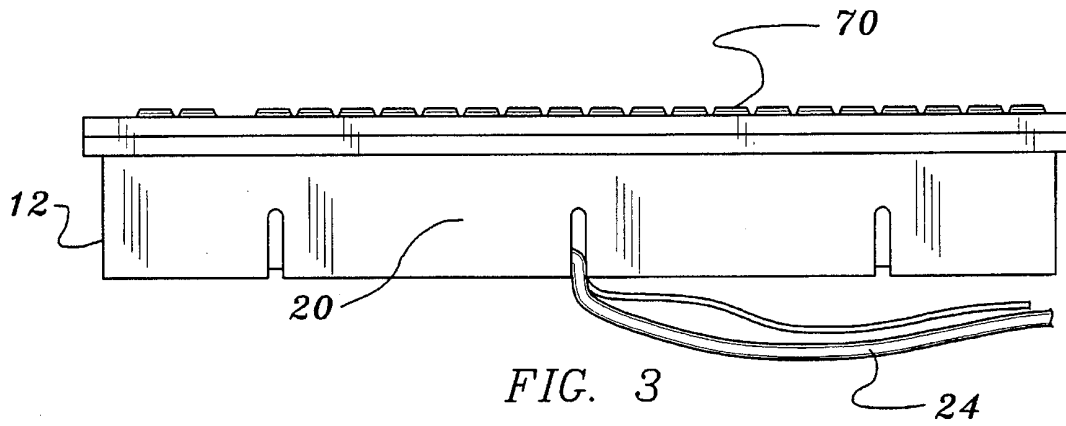

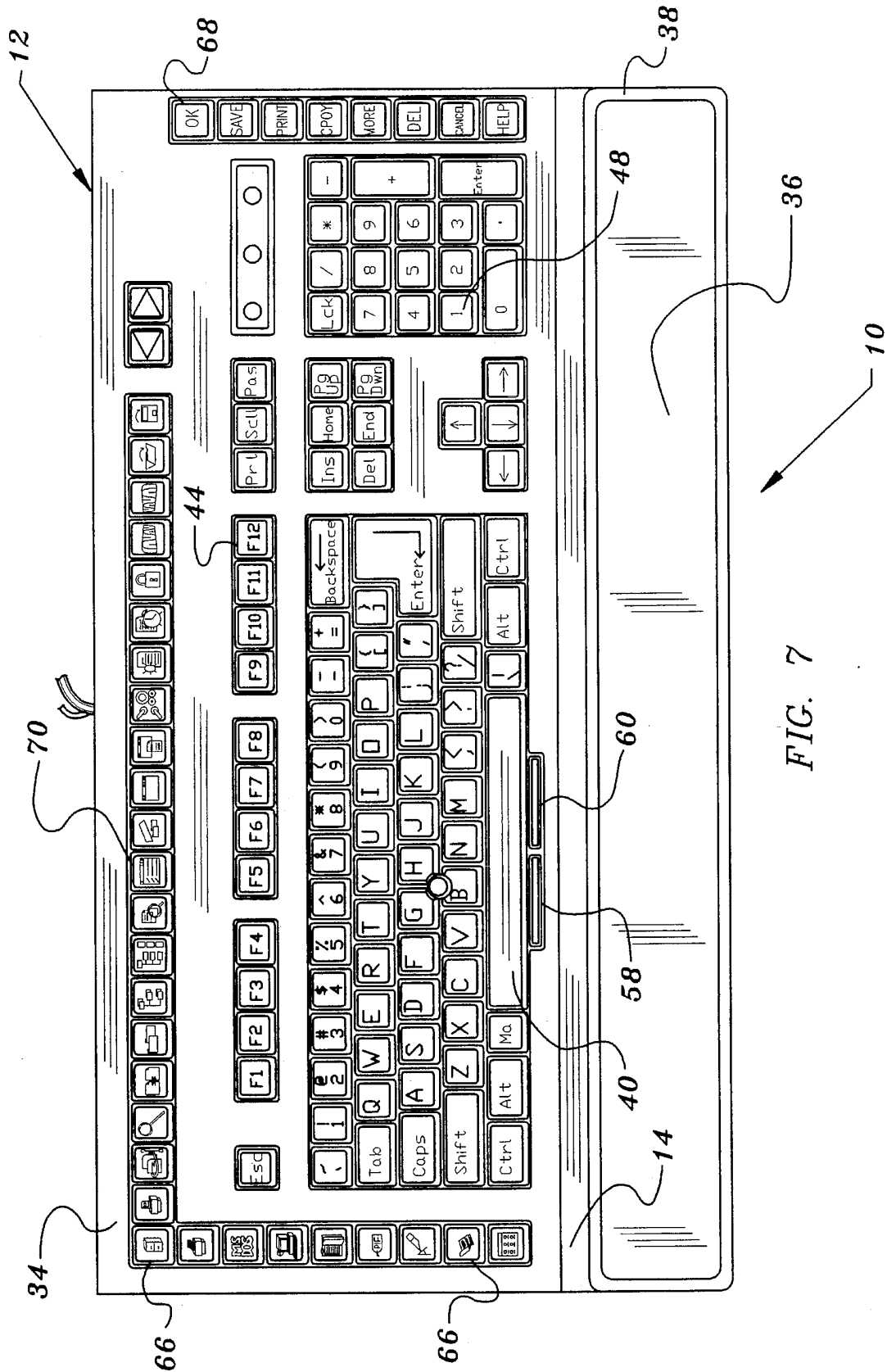

FIG. 7

**COMPUTER KEYBOARD****BACKGROUND OF THE INVENTION**

## 1. Field of the Invention

The present invention relates to a computer keyboard and more particularly pertains to providing a plurality of mouse buttons formed integrally with the top side of the keyboard, and further having a built-in wrist pad associated with the top side of the keyboard.

## 2. Description of the Prior Art

The use of a keyboard is known in the prior art. More specifically, a keyboard heretofore devised and utilized for the purpose of computer operation are known to consist basically of familiar, expected, and obvious structural configurations, notwithstanding the myriad of designs encompassed by the crowded prior art which has been developed for the fulfillment of countless objectives and requirements.

By way of example, U.S. Pat. No. 5,339,097 to Grant discloses a computer keyboard. U.S. Pat. No. 5,274,766 to Long and Ward discloses a universal keyboard and keyboard/spatial input device controller. U.S. Pat. No. Des. 346,161 to Oh and Lee discloses a keyboard for a computer. U.S. Pat. No. Des. 350,126 to Leung discloses a computer keyboard with built-in trackball. U.S. Pat. No. Des. 298,535 to Shim discloses a computer keyboard. Lastly, U.S. Pat. No. Des. 281,426 to Kurihara and Mizuno discloses a keyboard for an electronic computer.

While these devices fulfill their respective, particular objectives and requirements, the aforementioned patents do not describe computer keyboard that allows a computer user to control functions within an application through the use of a keyboard that incorporates a variety of programmable function icons along the periphery, and incorporates a plurality of mouse buttons integral with the top side of the keyboard.

In this respect, the computer keyboard according to the present invention substantially departs from the conventional concepts and designs of the prior art, and in doing so provides an apparatus primarily developed for the purpose of providing a plurality of mouse buttons formed integrally with the top side of the keyboard, and further having a built-in wrist pad associated with the top side of the keyboard.

Therefore, it can be appreciated that there exists a continuing need for a new and improved computer keyboard which uses a plurality of mouse buttons formed integrally with the top side of the keyboard, and further having a built-in wrist pad associated with the top side of the keyboard. In this regard, the present invention substantially fulfills this need.

**SUMMARY OF THE INVENTION**

In view of the foregoing disadvantages inherent in the known types of a keyboard now present in the prior art, the present invention provides an improved computer keyboard. As such, the general purpose of the present invention, which will be described subsequently in greater detail, is to provide a new and improved computer keyboard and method which has all the advantages of the prior art and none of the disadvantages.

To attain this, the present invention essentially comprises a generally rectangular keyboard body that has a top side, a bottom side, and a pair of short peripheral walls with a pair of long peripheral walls. Included is a keyboard mechanism

that is located on the top side of the keyboard body. The keyboard mechanism has an inner key area with a peripheral key area therearound. Also, a generally rectangular wrist pad is positioned on the top side of the keyboard below the inner key area and the peripheral key area. The wrist pad is perpendicular one of the long peripheral walls in a lower quadrant of the top side. The wrist pad is formed of a flexible material. The wrist pad has a length equal to a length of the long peripheral walls. Provided are a plurality of keys for depressing by movement of the fingers of a user in a first direction, when positioned within the inner key area of the keyboard mechanism. The plurality of keys form a space bar, function keys and alphabet keys. The plurality of keys are capable of being depressed while a wrist of the user rests on the wrist pad. Additionally, a pointing stick is positioned from the space bar and between the alphabet keys within the inner key area of the keyboard mechanism. The pointing stick is cylindrical and rotatable three and sixty hundred degrees. The pointing stick controls all movement of a cursor on a display screen of a computer by movement of stick with any two fingers of the user. A pair of mouse buttons are positioned along the inner key area of the keyboard mechanism and spaced from the space bar. The pair of mouse buttons form a right button and a left button. The right and left buttons function in accordance with the pointing stick when the user positions the cursor on an icon in a "WINDOWS" application on the display screen of the computer. Lastly, three sets of icon keys are provided. Each set is positioned within the peripheral key area of the keyboard mechanism. The three sets of icon keys form a set of static icon keys, a set of command icon keys and a set of tool bar icon keys. The set of static icon keys is positioned vertically on a left side of the keyboard mechanism. The set of command icon keys are positioned vertically on a right side of the keyboard mechanism. The tool bar icon keys are positioned horizontally above the function keys of the keyboard mechanism. The three sets of icon keys function within an application appearing on the display screen. The three sets of icon keys free up display screen space to allow more screen space for the application when the user is inputting useful data into the computer.

There has thus been outlined, rather broadly, the more important features of the invention in order that the detailed description thereof that follows may be better understood and in order that the present contribution to the art may be better appreciated. There are, of course, additional features of the invention that will be described hereinafter and which will form the subject matter of the claims appended hereto.

In this respect, before explaining at least one embodiment of the invention in detail, it is to be understood that the invention is not limited in its application to the details of construction and to the arrangements of the components set forth in the following description or illustrated in the drawings. The invention is capable of other embodiments and of being practiced and carried out in various ways. Also, it is to be understood that the phraseology and terminology employed herein are for the purpose of descriptions and should not be regarded as limiting.

As such, those skilled in the art will appreciate that the conception, upon which this disclosure is based, may readily be utilized as a basis for the designing of other structures, methods and systems for carrying out the several purposes of the present invention. It is important, therefore, that the claims be regarded as including such equivalent constructions insofar as they do not depart from the spirit and scope of the present invention.

It is therefore an object of the present invention to provide a new and improved computer keyboard which has all of the

# Explore Litigation Insights

Docket Alarm provides insights to develop a more informed litigation strategy and the peace of mind of knowing you're on top of things.

## Real-Time Litigation Alerts



Keep your litigation team up-to-date with **real-time alerts** and advanced team management tools built for the enterprise, all while greatly reducing PACER spend.

Our comprehensive service means we can handle Federal, State, and Administrative courts across the country.

## Advanced Docket Research



With over 230 million records, Docket Alarm's cloud-native docket research platform finds what other services can't. Coverage includes Federal, State, plus PTAB, TTAB, ITC and NLRB decisions, all in one place.

Identify arguments that have been successful in the past with full text, pinpoint searching. Link to case law cited within any court document via Fastcase.

## Analytics At Your Fingertips



Learn what happened the last time a particular judge, opposing counsel or company faced cases similar to yours.

Advanced out-of-the-box PTAB and TTAB analytics are always at your fingertips.

## API

Docket Alarm offers a powerful API (application programming interface) to developers that want to integrate case filings into their apps.

## LAW FIRMS

Build custom dashboards for your attorneys and clients with live data direct from the court.

Automate many repetitive legal tasks like conflict checks, document management, and marketing.

## FINANCIAL INSTITUTIONS

Litigation and bankruptcy checks for companies and debtors.

## E-DISCOVERY AND LEGAL VENDORS

Sync your system to PACER to automate legal marketing.