

[54]	<b>BANDAGE FOR THE ADMINISTRATION OF DRUG BY CONTROLLED METERING THROUGH MICROPOROUS MATERIALS</b>	3,598,123	8/1971	Zaffaroni.....	128/268
		3,426,754	2/1969	Bierenbaum.....	128/268 X
		3,053,255	9/1962	Meyer.....	128/268
		3,464,413	9/1969	Goldfarb et al.....	128/268
[75]	Inventor: <b>Alejandro Zaffaroni</b> , Atherton, Calif.	3,512,997	5/1970	Cohly et al.....	128/296 X

[73] Assignee: **Alza Corporation**, Palo Alto, Calif.  
 [ \* ] Notice: The portion of the term of this patent subsequent to Aug. 10, 1988, has been disclaimed.

*Primary Examiner*—Dalton L. Truluck  
*Assistant Examiner*—J. C. McGowan

[22] Filed: **Aug. 9, 1971**  
 [21] Appl. No.: **169,976**

**Related U.S. Application Data**

[63] Continuation-in-part of Ser. Nos. 812,116, April 1, 1969, Pat. No. 3,598,122, and Ser. No. 812,117, April 1, 1969, Pat. No. 3,598,123, and Ser. No. 150,085, June 4, 1971, Pat. No. 3,731,683.

[52] **U.S. Cl.** ..... **128/268**  
 [51] **Int. Cl.**..... **A61I 15/06**  
 [58] **Field of Search** ..... 128/260, 268, 156, 155, 128/296; 424/19, 20, 28

[57] **ABSTRACT**

A bandage for use in the continuous administration of drugs to the skin or mucosa, comprising a backing member defining one exterior surface, a surface of pressure-sensitive adhesive defining a second exterior surface, and disposed therebetween a reservoir containing drug formulation confined therein. The reservoir can comprise a distinct layer of the bandage or a plurality of microcapsules distributed throughout the adhesive surface, and in either case the drug can be confined within an interior chamber of the reservoir or distributed throughout a reservoir matrix. The drug passes through drug release rate controlling microporous material which continuously meters the flow of drug by viscous or diffusive transfer to the skin or mucosa at a controlled and predetermined rate over a period of time.

[56] **References Cited**  
**UNITED STATES PATENTS**  
 3,598,122 8/1971 Zaffaroni ..... 128/268

**7 Claims, 5 Drawing Figures**

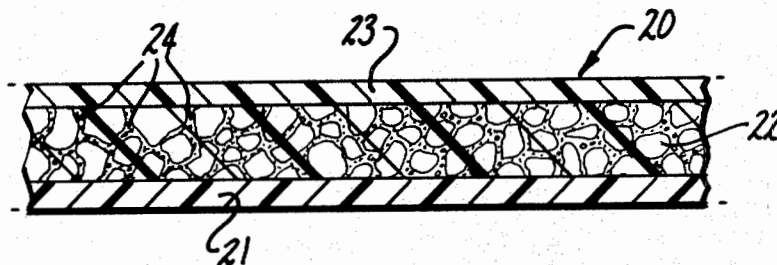

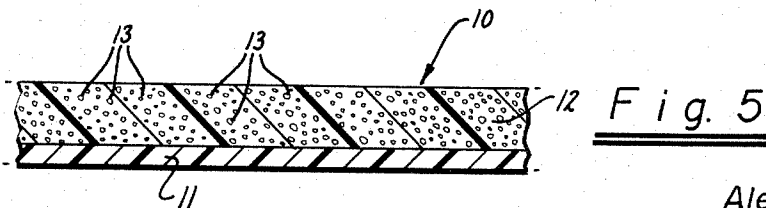
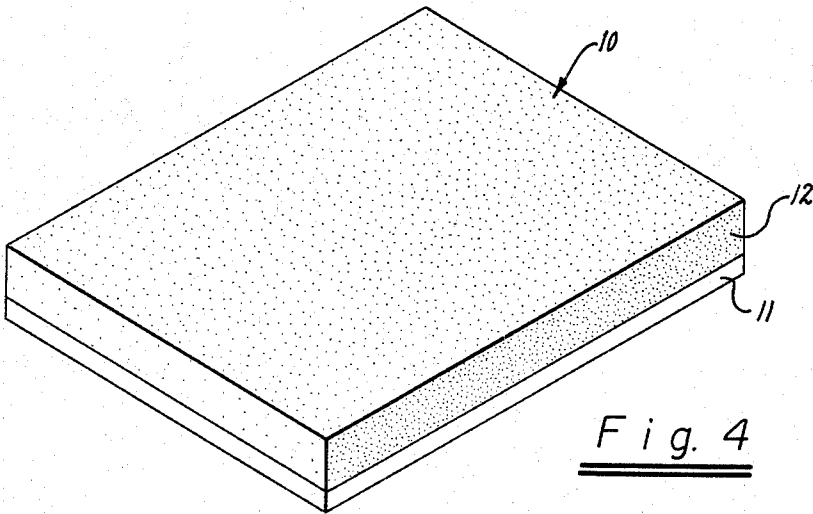
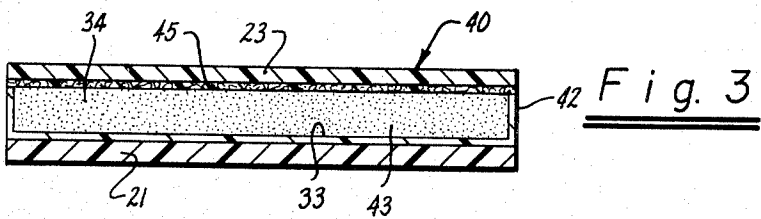
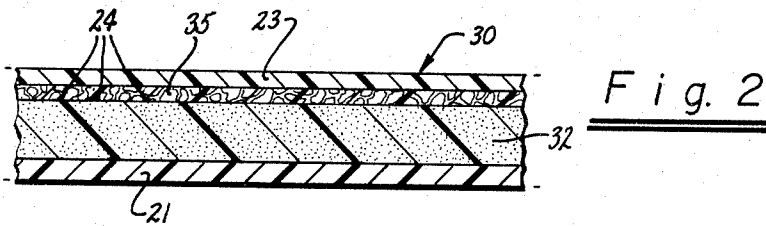
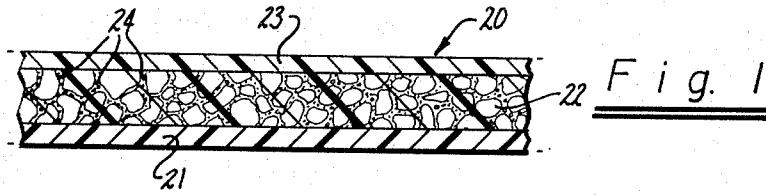

INVENTOR.

BY Alejandro Zaffaroni

**BANDAGE FOR THE ADMINISTRATION OF DRUG  
BY CONTROLLED METERING THROUGH  
MICROPOROUS MATERIALS**

**RELATED APPLICATIONS**

This application is a continuation-in-part of Ser. No. 812,116, filed Apr. 1, 1969, and now issued on Aug. 10, 1971 as U.S. Pat. No. 3,598,122 entitled "Bandage for Administering Drugs"; Ser. No. 812,117, filed Apr. 1, 1969, and now also issued on Aug. 10, 1971 as U.S. Pat. No. 3,598,123 entitled "Bandage"; and Ser. No. 150,085, filed June 4, 1971, and now issued on May 8, 1973 as U.S. Pat. No. 3,731,683 entitled "Bandage for the Controlled Metering of Topical Drugs to the Skin"; all being applications of Alejandro Zaffaroni.

**BACKGROUND OF THE INVENTION**

This invention relates to a device for the administration of drug and, more particularly, to a medical bandage for the controlled continuous metering of flow of systemically or topically active drug to the skin or mucosa over a period of time.

"Topically active" drugs, as that term is used in this specification and the appended claims, are agents which, when applied to the skin or mucosa, primarily cause a pharmacological or physiological response at or near the site of their application. "Systemically active" drugs, as that term is used in this specification and the appended claims, are agents which, when applied to the skin or mucosa, are absorbed through the body surface to which applied and are transported from their site of application by the recipient's circulatory system or lymphatic system, to cause a pharmacologic or physiological response at a remote site in the body.

Systemically active drugs are conventionally administered either orally or by injection, with the primary objective of the mode being to achieve a given desired blood level of drug in circulation over a period of time. However, these prior art methods possess certain shortcomings resulting in the failure to obtain these goals. For example, the oral route is inadequate for several reasons even though the drug is administered at periodic intervals according to a well defined schedule. The rate of absorption of drug through the gastrointestinal tract is affected by both the contents of the tract and the time of passage of drug through the small intestine. Therefore, such variables as whether the drug is administered before or after eating and the type and quantity of food eaten (for example, high or low fat content), or whether administered before or after a bowel movement, affect the rate of absorption of the drug which takes place in the small intestine. Additionally, the time of passage of drug through the small intestine is affected by the rate of peristaltic contracting, adding further uncertainty. Also important is the rate of circulation of blood to the small intestine and the fact that many drugs administered by this route are rendered inactive by gastric acid and digestive enzymes of the gastrointestinal tract or liver where the drug can be metabolized to an inactive product by that organ. These factors make it difficult to achieve a desired time course of concentration of the drug in the blood. The almost inevitable result of oral administration of drugs through the gastrointestinal tract is that the level of drug in circulation surges to a peak level at the time the drug is administered, followed by a decline in concentration in

the blood and body compartments. Thus, a plot of drug in circulation after administration of several tablets a day has the appearance of a series of peaks which may surpass the toxic threshold of the drug, and valleys which fall below the critical point needed to achieve the desired therapeutic effect.

The administration of drugs by injection can entail certain disadvantages. For example, very strict asepsis must be maintained to avoid infection of the blood, the vascular system or heart. Drug administration by poor intravenous injection technique may result in perivascular injection when it is not intended; and the typical result of injection into the blood is a sudden rise in the blood concentration followed by an uncontrolled decline. Additionally, administration of drugs by injection is inconvenient and painful. Other dosage forms for systemic administration of drug, such as rectal suppositories and sublingual lozenges, also produce non-uniform levels of the therapeutic agent in circulation. These dosage forms require great patient cooperation, have low patient acceptability, and are sparingly used throughout most of the world.

A large number of locally acting drugs are available to treat skin disorders or other conditions which manifest themselves in a manner such that they are susceptible to treatment via the skin. These drugs are conventionally topically administered to the skin with the active agent carried in the form of ointments, creams, salves, liniments, powders, dressings, and the like. The popularity of these types of formulations resides in the fact that it is quite easy to topically apply the agent to the skin in this manner. In most cases, however, it is not possible to determine how much of the preparation has been taken up or effectively administered to the skin since only non-uniform levels of the agent are available, nor is there any assurance that sufficient medication will be available for the duration of periods that it is required. A further undesirable feature is the unsightliness of these formulations which often discourages patients from using them during their waking hours of the day when they are most likely to be seen by others. Further, the preparations are subject to rub off onto clothing, thus causing much inconvenience and annoyance to the user.

**SUMMARY OF THE INVENTION**

Accordingly, an object of this invention is to provide a bandage for the improved continuous administration of a predetermined controlled quantity of topically or systemically active drug to or through the skin or body mucosa over a period of time, which overcomes the disadvantages inherent in the aforesaid prior art modes of administration.

Another object of this invention is to provide a bandage which can be adapted to deliver controlled quantities of drug having a wide variety of chemical and physical properties and over a wide range of drug delivery rates.

In accomplishing these objects, one feature of the invention resides in a bandage for the continuous administration of controlled quantities of drug to the skin or mucosa, comprised of a laminate of: (1) a backing member; bearing (2) a discrete middle reservoir layer containing a drug confined within a body, the body being formed from drug release rate controlling microporous material permeable to the passage of the drug, to continuously meter the flow of a therapeutically ef-



fective amount of the drug to the skin or mucosa from the reservoir at a controlled and predetermined rate over a period of time; and (3) a pressure-sensitive adhesive surface adapted for contact with the skin or mucosa and positioned on one surface of the reservoir remote from the backing member.

Another aspect of this invention resides in a bandage comprised of a laminate of: (1) a backing member; bearing (2) a discrete middle reservoir containing a drug confined therein, the reservoir being formed of material permeable to passage of the drug; and (3) a pressure-sensitive adhesive surface adapted for contact with the skin or mucosa and positioned on one surface of the reservoir remote from the backing member and wherein one or more drug release rate controlling microporous membranes are interposed between the surface of the reservoir and pressure-sensitive adhesive so as to continuously meter the flow of a therapeutically effective amount of the drug from the reservoir at a controlled and predetermined rate over a period of time. The reservoir can be a container having the agent confined therein or a solid or microporous matrix having agent dispersed therein.

Still another embodiment of this invention resides in an adhesive bandage comprising a laminate of: (1) a backing member; bearing (2) a pressure-sensitive adhesive on one surface thereof adapted for contact with the skin or mucosa, said pressure-sensitive adhesive having distributed therethrough, (3) a plurality of discrete microcapsules, each of which microcapsules comprises a drug confined within a body of drug release rate controlling porous material to continuously meter the flow of a therapeutically effective amount of the drug to the skin or mucosa of the patient from the microcapsules at a controlled and predetermined rate over a period of time.

Other objects, features and advantages of the invention will become more apparent from the following description when taken in conjunction with the accompanying drawings.

The term "reservoir", as used herein to define the drug containing portion of the subject bandage, is intended to connote a broad class of structures capable of fulfilling the intended function, and includes both discrete porous microcapsules, as well as distinct reservoir compartments or layers. Likewise, as will be hereinafter more completely developed, the foregoing term encompasses containers having one or more interior drug containing chambers, as well as solid matrices and microporous matrices having a systemically or topically active drug distributed therethrough.

The term "drug or agent", when not further qualified, includes both topically active and systemically active drugs, as hereinbefore defined.

#### BRIEF DESCRIPTION OF THE DRAWINGS

In the drawings:

FIG. 1 is a cross-sectional view of an embodiment of the medical bandage of the invention, wherein the drug is uniformly distributed throughout a matrix of microporous material permeable to the passage of the drug by flow through the pores of the material and the material is laminated to a backing member. The matrix material which acts as a reservoir for the drug bears a coating of the pressure-sensitive adhesive thereon;

FIG. 2 is a cross-sectional view of still another embodiment of the invention, wherein the adhesive ban-

dage of the invention is comprised of a backing member having a reservoir on one surface thereof of drug uniformly distributed throughout a matrix material permeable to passage of the drug, and on the surface of the reservoir remote from the backing member bearing a pressure-sensitive adhesive coating. A microporous membrane is interposed between the reservoir layer and the pressure-sensitive adhesive coating;

FIG. 3 is a cross-sectional view of another embodiment of the invention, wherein the reservoir laminated to the backing member is a hollow container permeable to passage of drug by flow through the pores of one surface thereof, and having the drug confined within the interior chamber thereof. The reservoir bears a coating of pressure-sensitive adhesive thereon;

FIG. 4 is a perspective view of the medical adhesive bandage of the invention, wherein the drug is microencapsulated with a porous material permeable to the passage of the drug, and the microcapsules are uniformly distributed throughout the pressure-sensitive coating;

FIG. 5 is a cross-sectional view of the bandage of the invention shown in FIG. 4.

#### DETAILED DESCRIPTION OF THE INVENTION

In accordance with this invention there is provided a bandage suitable, by virtue of the microporous materials employed therein, for the predetermined controlled administration of drug to the skin or mucosa of the body over a period of time. To use the bandage of the invention it is applied to the patient's skin or mucosa and should be in firm contact therewith so as to form a tight seal. Flow of drug from the reservoir is metered through the pores of the rate release controlling material in accordance with the laws of hydrodynamics or diffusion, as hereinafter discussed, at a predetermined rate. In operation, drug molecules are continuously removed from the reservoir and migrate to the skin or mucosa of the patient. In the case of systemic drugs, the drugs are absorbed by the skin or mucosa and enter circulation through the capillary network.

The reservoir containing the drug is formed of material permeable to the drug to permit passage of the drug. Depending upon the particular embodiment as described above, the drug reservoir can be of microporous material or otherwise. However, as is apparent in the latter case, the drug must first pass through a microporous membrane material prior to reaching the skin or mucosa. It is therefore critical to the practice of this invention for all embodiments that, at some point after or concurrent with the release of drug from the reservoir and prior to reaching the skin or mucosa, the drug pass through the drug release rate controlling microporous membrane or matrix material to meter the flow thereof. The rate of passage or permeation of drug through the microporous material is determined by the transfer mechanism which can be either by:

1. diffusive flux of drug molecules as is the case, as hereinafter described, where the micropores of the rate controlling microporous membrane or matrix material are impregnated with a diffusive medium for the drug in which the drug molecules can dissolve in and flow through to a direction of lower chemical potential; or

2. pressure induced viscous type flow of drug molecules through the pores in the microporous membrane or matrix rate controlling material.

Thus, the microporous material has a structure that enables the drug to pass through the pre-existing pores or capillaries, either by diffusive permeability or microporous hydrodynamic flow, depending upon the mode of use as described hereinafter. Since the microporous rate controlling material is preferably selected so that the drug is substantially insoluble therein, as hereinafter described, flow of drug through the structure of the material can be neglected.

For drug transfer mechanism (1) set forth above, i.e., wherein the drug diffuses through a diffusive medium for the drug, the release rate can be controlled in accordance with Fick's First Law, depending on the particular design by selection of dependent variables such as the diffusivity and solubility of the drug in the diffusive medium and the thickness and porosity of the material properly modified by a tortuosity factor. For drug transfer mechanism (2), i.e., flow of drug through the pores of the microporous rate controlling material, the pressure differential, the thickness of the membrane, the viscosity of the permeant drug, the size of the permeant molecule relative to the pore size, the absolute value of the pore size, and the number of pores or percent voids in the material are the controlling factors governing permeability. For the simplest type of flow mechanism of this type, e.g., viscous flow, the amount of drug passing through the porous structure is given by Poiseuille's equation for viscous flow.

Therefore, the selection of appropriate materials for fabricating the microporous rate controlling membrane or matrix material will be dependent on the particular drug to be used in the bandage. Both organic and inorganic polymeric materials can be shaped into a wide variety of forms with tailored morphology and a wide range of chemical and physical properties to advantageously control release of a wide variety of drugs, including those with large molecular structures such as insulin, and over a large dosage range rate appropriate pore size selection. Additionally, by impregnating the interconnected pores of the microporous structure with a diffusive medium for the drug to be administered, a given microporous membrane or matrix material can be adapted to control the release of drugs having a wide range of chemical properties by diffusive permeability. Thus, by varying the composition, pore size, and effective thickness of the microporous rate controlling material, the viscosity of the drug to be administered by appropriate formulation or by impregnating the material with suitable solvent, the dosage rate per area of bandage can be controlled since the material functions to meter the flow of drug from the device. Therefore, bandages of the same surface area can provide different dosages of a drug by varying the above discussed parameters.

The microporous rate controlling materials of this invention are known in the art and can be visualized as a plurality of sponge-like fused polymer particles which provide a supporting structure having therethrough a dispersion of microscopic sized interconnecting voids or pores. The rate controlling structures formed from the materials can be isotropic, wherein the structure is homogeneous throughout the cross-section of the matrix or membrane material, or anisotropic wherein the

structures are commercially available and can be made by a multitude of different methods, e.g., etched nuclear track, and materials employed, e.g., polyelectrolyte, ion exchange polymers, as described in R. E. Kesting, *Synthetic Polymer Membranes*, McGraw Hill, Chapters 4 and 5, 1971; J. D. Ferry, *Ultrafiltration Membranes*, Chemical Review, Vol. 18, Page 373, 1934. Materials possessing from 5 percent to 95 percent voids and having an effective pore size of from about 10 angstroms to about 100 microns can be suitably employed in the practice of this invention. Materials with pore sizes significantly below 50 angstroms can be considered to be molecular diffusion type membranes and matrices. In order to obtain the most advantageous results, the materials should be formed into structures with the desired morphology in accordance with methods known to those skilled in the art to achieve the desired release rate of drug. Additionally, the material must have the appropriate chemical resistance to the drug used and be non-toxic when used as an element of the bandage of the invention.

Materials useful in forming the microporous rate controlling materials used in this invention include, but are not limited to the following.

Polycarbonates, i.e., linear polyesters of carbonic acids in which carbonate groups recur in the polymer chain, by phosgenation of a dihydroxy aromatic such as bisphenol A. Such materials are sold under the trade designation Lexan by the General Electric Company.

Polyvinylchlorides; one such material is sold under the trade designation Geon 121 by B. G. Goodrich Chemical Company.

Polyamides such as polyhexamethylene adipamide and other such polyamides popularly known as "nylon". One particularly advantageous material is that sold under the trade name "NOMEX" by E. I. DuPont de Nemours & Co.

Modacrylic copolymers, such as that sold under the trade designation DYNEL and formed of polyvinylchloride (60 percent) and acrylonitrile (40 percent), styrene-acrylic acid copolymers, and the like.

Polysulfones such as those of the type characterized by diphenylene sulfone groups in the linear chain thereof are useful. Such materials are available from Union Carbide Corporation under the trade designation P-1700.

Halogenated polymers such as polyvinylidene fluoride sold under the trade designation Kynar by Pennsalt Chemical Corporation, polyvinylfluoride sold under the trade name Tedlar by E. I. DuPont de Nemours & Co., and the polyfluorohalocarbon sold under the trade name Aclar by Allied Chemical Corporation.

Polychloroethers such as that sold under the trade name Penton by Hercules Incorporated, and other such thermoplastic polyethers.

Acetal polymers such as the polyformaldehyde sold under the trade name Delrin by E. I. DuPont de Nemours & Co., and the like.

Acrylic resins such as polyacrylonitrile polymethyl methacrylate, poly n-butyl methacrylate and the like.

Other polymers such as polyurethanes, polyimides, polybenzimidazoles, polyvinyl acetate, aromatic and aliphatic, polyethers, cellulose esters, e.g., cellulose triacetate; cellulose; collodion (cellulose nitrate with 11% nitrogen); epoxy resins; olefins, e.g., polyethylene polypropylene; porous rubber; cross-linked poly (ethylene

# Explore Litigation Insights

Docket Alarm provides insights to develop a more informed litigation strategy and the peace of mind of knowing you're on top of things.

## Real-Time Litigation Alerts



Keep your litigation team up-to-date with **real-time alerts** and advanced team management tools built for the enterprise, all while greatly reducing PACER spend.

Our comprehensive service means we can handle Federal, State, and Administrative courts across the country.

## Advanced Docket Research



With over 230 million records, Docket Alarm's cloud-native docket research platform finds what other services can't. Coverage includes Federal, State, plus PTAB, TTAB, ITC and NLRB decisions, all in one place.

Identify arguments that have been successful in the past with full text, pinpoint searching. Link to case law cited within any court document via Fastcase.

## Analytics At Your Fingertips



Learn what happened the last time a particular judge, opposing counsel or company faced cases similar to yours.

Advanced out-of-the-box PTAB and TTAB analytics are always at your fingertips.

## API

Docket Alarm offers a powerful API (application programming interface) to developers that want to integrate case filings into their apps.

## LAW FIRMS

Build custom dashboards for your attorneys and clients with live data direct from the court.

Automate many repetitive legal tasks like conflict checks, document management, and marketing.

## FINANCIAL INSTITUTIONS

Litigation and bankruptcy checks for companies and debtors.

## E-DISCOVERY AND LEGAL VENDORS

Sync your system to PACER to automate legal marketing.