



**RESPONSE UNDER 37 C.F.R. §1.116**  
**EXPEDITED PROCEDURE**  
**EXAMINING GROUP ART UNIT 1631**

**IN THE UNITED STATES PATENT AND TRADEMARK OFFICE**

Applicant(s):	Stavrianopoulos, <i>et al.</i>	)	
Serial No.:	08/486,070	)	Group Art Unit: 1631
Filed:	June 7, 1995	)	Ex'r: Ardin H. Marschel, Ph.D.
For:	ARRAYS AND SYSTEMS COMPRISING	)	
	ARRAYS FOR GENETIC ANALYSES AND	)	
	OTHER APPLICATIONS	)	
	(As Previously Amended)	)	

527 Madison Avenue, 9<sup>th</sup> Floor  
New York, NY 10022-4304  
June 30, 2004

**VIA EXPRESS MAIL**

Mail Stop Amendment  
Commissioner for Patents  
P.O. Box 1450  
Alexandria, VA 22313-1450

**AMENDMENT UNDER 37 C.F.R. §1.116**  
**(IN RESPONSE TO THE APRIL 7, 2004 OFFICE ACTION)**

Dear Sirs:

This is a response (Amendment Under 37 C.F.R. §1.116) to the Office Action mailed on April 7, 2004 in connection with the above-identified application. A response to the April 7, 2004 Office Action is initially due by July 7, 2004. Accordingly, this response (Amendment Under 37 C.F.R. §1.116) is being timely filed and no extension request or fees are believed due.

---

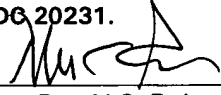
EXPRESS MAIL CERTIFICATE	
"Express Mail" Label No. <u>EV531083255US</u>	
Deposit Date <u>June 30, 2004</u>	
I hereby certify that this paper and the attachments herein are being deposited with the United States Postal Service "Express Mail Post Office to Addressee" service under 37 CFR 1.10 on the date indicated above and is addressed to the Commissioner of Patents and Trademarks, Washington DC 20231.	
	<u>JUNE 30 2004</u>
Ronald C. Fedus Reg. No. 32,567	Date

---

**KINDLY AMEND THE ABOVE-IDENTIFIED APPLICATION AS FOLLOWS:**

**In The Title of the Invention:** Change the title to:

-- Nucleic Acids Fixed or Immobilized to Non-Porous Solid Support, and System, Array and Non-Porous Glass or Plastic Solid Support Comprising Such Fixed or Immobilized Nucleic Acids -- .

**In The Claims:** Please enter the complete listing of all claims provided below.

Claims 1-2160 (Previously Canceled).

Claims 2161-3143 (Canceled).

Claim 3144. (New) A non-porous solid support comprising at least one single-stranded nucleic acid directly or indirectly fixed or immobilized thereto in hybridizable form, wherein when said nucleic acid is indirectly fixed or immobilized to said non-porous solid support, said indirect fixation or immobilization is not to a cell fixed *in situ* to said non-porous solid support.

Claim 3145. (New) A non-porous solid support comprising at least one double-stranded nucleic acid fixed or immobilized thereto, wherein at least one nucleic acid strand of said double-stranded nucleic acid comprises at least one non-radioactive chemical label which is quantifiable or detectable, wherein when said nucleic acid is indirectly fixed or immobilized to said non-porous solid support, said indirect fixation or immobilization is not to a cell fixed *in situ* to said non-porous solid support.

Claim 3146. (New) The non-porous solid support of claim 3144 or 3145, wherein said non-porous solid support comprises glass or plastic.

Claim 3147. (New) The non-porous solid support of claim 3144 or 3145, wherein said non-porous solid support comprises a plate, a well or wells, a microtiter well or microtiter wells, depressions, tubes, cuvettes, beads, or a set of said plates, wells, depressions, tubes, cuvettes or beads.

Claim 3148. (New) The non-porous solid support of claim 3144 or 3145, wherein said non-porous solid support comprises more than one surface.

Claim 3149. (New) The non-porous solid support of claim 3144 or 3145, comprising reactive sites or binding sites thereon, wherein said nucleic acid is fixed or immobilized to one of said reactive sites or binding sites.

Claim 3150. (New) The non-porous solid support of claim 3149, wherein said reactive sites or binding sites comprise one or more amines, hydroxyls or epoxides.

Claim 3151. (New) The non-porous solid support of claim 3144 or 3145, wherein said non-porous solid support has been treated with a surface treatment agent, a blocking agent, or both.

Claim 3152. (New) The non-porous solid support of claim 3151, wherein said surface treatment agent comprises an amine providing compound, an epoxy glue or solution, an acid solution, or ammonium acetate.

Claim 3153. (New) The non-porous solid support of claim 3151, wherein said blocking agent comprises Denhardt's solution.

Claim 3154. (New) The non-porous solid support of claim 3144 or 3145, wherein said direct or indirect fixation or immobilization to said non-porous solid support is covalent.

Claim 3155. (New) The non-porous solid support of claim 3144 or 3145, wherein said direct or indirect fixation or immobilization to said non-porous solid support is non-covalent.

Claim 3156. (New) The non-porous solid support of claim 3144, wherein said single-stranded nucleic acid is indirectly fixed or immobilized to said non-porous solid support by sandwich hybridization or by hybridization to a complementary nucleic acid strand.

Claim 3157. (New) The non-porous solid support of claim 3145, wherein one strand of said double-stranded nucleic acid is indirectly fixed or immobilized to said non-porous solid support by sandwich hybridization or by hybridization to a complementary nucleic acid strand.

Claim 3158. (New) The non-porous solid support of claim 3144, wherein said nucleic acid comprises DNA or RNA.

Claim 3159. (New) The non-porous solid support of claim 3145, wherein said nucleic acid comprises DNA, RNA or both.

Claim 3160. (New) The non-porous solid support of claim 3144, wherein said nucleic acid comprises a nucleic acid sequence complementary to a nucleic acid sequence of interest sought to be identified, quantified or sequenced.

Claim 3161. (New) The non-porous solid support of claim 3145, wherein one strand of said double-stranded nucleic acid comprises a nucleic acid sequence of interest sought to be identified, quantified or sequenced.

Claim 3162. (New) The non-porous solid support of claim 3144, wherein said single-stranded nucleic acid is unlabeled.

Claim 3163. (New) The non-porous solid support of claim 3144 or 3145, wherein said non-porous solid support is transparent or translucent.

Claim 3164. (New) The non-porous solid support of claim 3145, wherein said non-radioactive chemical label is quantifiable in or from a fluid or solution, said quantity being proportional to the amount or quantity of said label or labels.

Claim 3165. (New) The non-porous solid support of claim 3145, wherein said non-porous solid support is transparent or translucent, and said non-radioactive chemical label is quantifiable in or from a fluid or solution or in or through said non-porous solid support, said quantity being proportional to the amount or quantity of said label or labels.

Claim 3166. (New) The non-porous solid support of claim 3145, wherein said non-radioactive chemical label comprises a chromagen or a chromagenic compound, a colored dye compound, a fluorogen or a fluorescent compound, a chemiluminescent compound, a chelating compound, an enzyme or an enzymatic compound, a coenzyme, biotin, iminobiotin, a hapten or a ligand.

Claim 3167. (New) The non-porous solid support of claim 3145, wherein a non-radioactive signal from said non-radioactive chemical label is quantifiable or detectable by photometric techniques, spectrophotometric techniques, colorimetric techniques, fluorometric techniques or chemiluminescent techniques.

Claim 3168. (New) The non-porous solid support of claim 3144, comprising more than one single-stranded nucleic acid.

Claim 3169. (New) The non-porous solid support of claim 3145, comprising more than one double-stranded nucleic acid.

Claim 3170. (New) A set comprising the non-porous solid support of claim 3144.

Claim 3171. (New) A set comprising the non-porous solid support of claim 3145.

Claim 3172. (New) A system comprising a non-porous solid support and at least one single-stranded nucleic acid directly or indirectly fixed or immobilized thereto in hybridizable form, wherein when said nucleic acid is indirectly fixed or immobilized to said non-porous solid support, said indirect fixation or immobilization is not to a cell fixed *in situ* to said non-porous solid support.

Claim 3173. (New) A system comprising a non-porous solid support and at least one double-stranded nucleic acid fixed or immobilized thereto, wherein at least one nucleic acid strand of said double-stranded nucleic acid comprises at least one non-radioactive chemical label which is quantifiable or detectable, and wherein when said nucleic acid is indirectly fixed or immobilized to said non-porous solid support, said indirect fixation or immobilization is not to a cell fixed *in situ* to said non-porous solid support.

Claim 3174. (New) The system of claim 3172 or 3173, wherein said non-porous solid support comprises glass or plastic.

Claim 3175. (New) The system of claim 3172 or 3173, wherein said non-porous solid support comprises a plate, a well or wells, a microtiter well or microtiter wells, depressions, tubes, cuvettes, beads, or a set of said plates, wells, depressions, tubes, cuvettes or beads.

Claim 3176. (New) The system of claim 3172 or 3173, wherein said non-porous solid support comprises more than one surface.

Claim 3177. (New) The system of claim 3172 or 3173, wherein said non-porous solid support comprises reactive sites or binding sites thereon, wherein said nucleic acid is fixed or immobilized to one of said reactive sites or binding sites.

Claim 3178. (New) The system of claim 3177, wherein said reactive sites or binding sites comprise one or more amines, hydroxyls or epoxides.

Claim 3179. (New) The system of claim 3172 or 3173, wherein said non-porous solid support has been treated with a surface treatment agent, a blocking agent, or both.

Claim 3180. (New) The system of claim 3179, wherein said surface treatment agent comprises an amine providing compound, an epoxy glue or solution, an acid solution or ammonium acetate.



Claim 3181. (New) The system of claim 3179, wherein said blocking agent comprises Denhardt's solution.

Claim 3182. (New) The system of claim 3172 or 3173, wherein said direct or indirect fixation or immobilization to said non-porous solid support is covalent.

Claim 3183. (New) The system of claim 3172 or 3173, wherein said direct or indirect fixation or immobilization to said non-porous solid support is non-covalent.

Claim 3184. (New) The system of claim 3172, wherein said single-stranded nucleic acid is indirectly fixed or immobilized to said non-porous solid support by sandwich hybridization or by hybridization to a complementary nucleic acid strand.

Claim 3185. (New) The system of claim 3173, wherein said one strand of said double-stranded nucleic acid is indirectly fixed or immobilized to said non-porous solid support by sandwich hybridization or by hybridization to a complementary nucleic acid strand.

Claim 3186. (New) The system of claim 3172, wherein said nucleic acid comprises DNA or RNA.

Claim 3187. (New) The system of claim 3173, wherein said nucleic acid comprises DNA, RNA, or both.

Claim 3188. (New) The system of claim 3172, wherein said nucleic acid comprises a nucleic acid sequence complementary to a nucleic acid sequence of interest sought to be identified, quantified or sequenced.

Claim 3189. (New) The system of claim 3173, wherein one strand of said double-stranded nucleic acid comprises a nucleic acid sequence of interest sought to be identified, quantified or sequenced.

Claim 3190. (New) The system of claim 3172, wherein said single-stranded nucleic acid is unlabeled.

Claim 3191. (New) The system of claim 3172 or 3173, wherein said non-porous solid support is transparent or translucent.

Claim 3192. (New) The system of claim 3173, wherein said non-radioactive chemical label is quantifiable in or from a fluid or solution, said quantity being proportional to the amount or quantity of said label or labels.

Claim 3193. (New) The system of claim 3173, wherein said non-porous solid support is transparent or translucent, and said non-radioactive chemical label is quantifiable in or from a fluid or solution or in or through said non-porous solid support, said quantity being proportional to the amount or quantity of said label or labels.

Claim 3194. (New) The system of claim 3173, wherein said non-radioactive chemical label comprises a chromagen or a chromagenic compound, a colored dye compound, a fluorogen or a fluorescent compound, a chemiluminescent compound, a chelating compound, an enzyme or an enzymatic compound, a coenzyme, biotin, iminobiotin, a hapten or a ligand.

Claim 3195. (New) The system of claim 3173, wherein a non-radioactive signal from said non-radioactive chemical label is quantifiable or detectable by photometric techniques, spectrophotometric techniques, colorimetric techniques, fluorometric techniques or chemiluminescent techniques.

Claim 3196. (New) The system of claim 3172, comprising more than one single-stranded nucleic acid.

Claim 3197. (New) The system of claim 3173, comprising more than one double-stranded nucleic acid.

Claim 3198. (New) An array comprising various single-stranded nucleic acids directly or indirectly fixed or immobilized in hybridizable form to a non-porous solid support, wherein when said nucleic acids are indirectly fixed or immobilized to said non-porous solid support, said indirect fixation or immobilization is not to a cell fixed *in situ* to said non-porous solid support.

Claim 3199. (New) An array comprising various double-stranded nucleic acids directly or indirectly fixed or immobilized to a non-porous solid support, wherein at least one nucleic acid strand of said various double-stranded nucleic acids comprises at least one non-radioactive chemical label which is quantifiable or detectable, and wherein when said nucleic acids are indirectly fixed or immobilized to said non-porous solid support, said indirect fixation or immobilization is not to a cell fixed *in situ* to said non-porous solid support.

Claim 3200. (New) The array of claim 3198 or 3199, wherein said non-porous solid support comprises glass or plastic.

Claim 3201. (New) The array of claim 3198 or 3199, wherein said non-porous solid support comprises a plate, a well or wells, a microtiter well or microtiter wells, depressions, tubes, cuvettes, beads, or a set of said plates, wells, depressions, tubes, cuvettes or beads.

Claim 3202. (New) The array of claim 3198 or 3199, wherein said non-porous solid support comprises more than one surface.

Claim 3203. (New) The array of claim 3198 or 3199, comprising reactive sites or binding sites thereon, wherein said nucleic acids are fixed or immobilized to said reactive sites or binding sites.

Claim 3204. (New) The array of claim 3203, wherein said reactive sites or binding sites comprise one or more amines, hydroxyls or epoxides.

Claim 3205. (New) The array of claim 3198 or 3199, wherein said non-porous solid support has been treated with a surface treatment agent, a blocking agent, or both.

Claim 3206. (New) The array of claim 3205, wherein said surface treatment agent comprises an amine providing compound, an epoxy glue or solution, an acid solution or ammonium acetate.

Claim 3207. (New) The array of claim 3205, wherein said blocking agent comprises Denhardt's solution.

Claim 3208. (New) The array of claim 3198 or 3199, wherein said direct or indirect fixation or immobilization to said non-porous solid support is covalent

Claim 3209. (New) The array of claim 3198 or 3199, wherein said direct or indirect fixation or immobilization to said non-porous solid support is non-covalent.

Claim 3210. (New) The array of claim 3198, wherein said single-stranded nucleic acids or sequences are indirectly fixed or immobilized to said non-porous solid support by sandwich hybridization or by hybridization to complementary nucleic acid strands.

Claim 3211. (New) The array of claim 3199, wherein one strand of said double-stranded nucleic acids or sequences is indirectly fixed or immobilized to said non-porous solid support by sandwich hybridization or by hybridization to complementary nucleic acid strands.

Claim 3212. (New) The array of claim 3198, wherein said nucleic acids comprise DNA or RNA.

Claim 3213. (New) The array of claim 3199, wherein said nucleic acids comprise DNA, RNA, or both.

Claim 3214. (New) The array of claim 3198, wherein said nucleic acids comprise nucleic acid sequences complementary to nucleic acid sequences of interest sought to be identified, quantified or sequenced.

Claim 3215. (New) The array of claim 3199, wherein one strand of said double-stranded nucleic acids comprises a nucleic acid sequence of interest sought to be identified, quantified or sequenced.

Claim 3216. (New) The array of claim 3198, wherein said single-stranded nucleic acids are unlabeled.

Claim 3217. (New) The array of claim 3198 or 3199, wherein said non-porous solid support is transparent or translucent.

Claim 3218. (New) The array of claim 3199, wherein said non-radioactive chemical label is quantifiable in or from a fluid or solution, said quantity being proportional to the amount or quantity of said label or labels.

Claim 3219. (New) The array of claim 3199, wherein said non-porous solid support is transparent or translucent, and said non-radioactive chemical label is quantifiable in or from a fluid or solution or in or through said non-porous solid support, said quantity being proportional to the amount or quantity of said label or labels.

Claim 3220. (New) The array of claim 3199, wherein said non-radioactive chemical label comprises a chromagen or a chromagenic compound, a colored dye compound, a fluorogen or a fluorescent compound, a chemiluminescent compound, a chelating compound, an enzyme or an enzymatic compound, a coenzyme, biotin, iminobiotin, a hapten or a ligand.

Claim 3221. (New) The array of claim 3199, wherein a non-radioactive signal from said non-radioactive chemical label is quantifiable or detectable by photometric techniques, spectrophotometric techniques, colorimetric techniques, fluorometric techniques or chemiluminescent techniques.

Claim 3222. (New) An array comprising various single-stranded nucleic acids directly or indirectly fixed or immobilized in hybridizable form to a non-porous solid support having wells or depressions, wherein when said nucleic acids are indirectly fixed or immobilized to said wells or depressions of said non-porous solid support, said indirect fixation or immobilization is not to a cell fixed *in situ* to said wells or depressions of said non-porous solid support.

Claim 3223. (New) An array comprising various double-stranded nucleic acids directly or indirectly fixed or immobilized to a non-porous solid support having wells or depressions, wherein at least one nucleic acid strand of said various double-stranded nucleic acids comprises at least one non-radioactive chemical label which is quantifiable or detectable, and wherein when said nucleic acids are indirectly fixed or immobilized to said wells or depressions of said non-porous solid support, said indirect fixation or immobilization is not to a cell fixed *in situ* to said wells or depressions of said non-porous solid support.

Claim 3224. (New) The array of claim 3222 or 3223, wherein said non-porous solid support comprises glass or plastic.

Claim 3225. (New) The array of claim 3222 or 3223, wherein said wells or depressions comprise a plate of wells or depressions, or a microtiter plate of wells or depressions.

Claim 3226. (New) The array of claim 3222 or 3223, comprising reactive sites or binding sites thereon, wherein said nucleic acids are fixed or immobilized to said reactive sites or binding sites.

Claim 3227. (New) The array of claim 3226, wherein said reactive sites or binding sites comprise one or more amines, hydroxyls or epoxides.

Claim 3228. (New) The array of claim 3222 or 3223, wherein said non-porous solid support has been treated with a surface treatment agent, a blocking agent, or both.

Claim 3229. (New) The array of claim 3228, wherein said surface treatment agent comprises an amine providing compound, an epoxy glue or solution, an acid solution or ammonium acetate.

Claim 3230. (New) The array of claim 3228, wherein said blocking agent comprises Denhardt's solution.

Claim 3231. (New) The array of claim 3222 or 3223, wherein said direct or indirect fixation or immobilization to said non-porous solid support is covalent.

Claim 3232. (New) The array of claim 3222 or 3223, wherein said direct or indirect fixation or immobilization to said non-porous solid support is non-covalent.

Claim 3233. (New) The array of claim 3222, wherein said single-stranded nucleic acids are indirectly fixed or immobilized to said non-porous solid support by sandwich hybridization or by hybridization to complementary nucleic acid strands.

Claim 3234. (New) The array of claim 3223, wherein one strand of said double-stranded nucleic acids is indirectly fixed or immobilized to said non-porous solid support by sandwich hybridization or by hybridization to complementary nucleic acid strands.



Claim 3235. (New) The array of claim 3222, wherein said nucleic acids comprise DNA or RNA.

Claim 3236. (New) The array of claim 3223, wherein said nucleic acids comprise DNA, RNA, or both.

Claim 3237. (New) The array of claim 3222, wherein said nucleic acids comprise nucleic acid sequences complementary to nucleic acid sequences of interest sought to be identified, quantified or sequenced.

Claim 3238. (New) The array of claim 3223, wherein one strand of said double-stranded nucleic acids comprises a nucleic acid sequence of interest sought to be identified, quantified or sequenced.

Claim 3239. (New) The array of claim 3223, wherein said nucleic acid sequence of interest sought to be identified, quantified or sequenced comprises a gene sequence or pathogen sequence.

Claim 3240. (New) The array of claim 3222, wherein said single-stranded nucleic acids are unlabeled.

Claim 3241. (New) The array of claim 3222 or 3223, wherein said non-porous solid support is transparent or translucent.

Claim 3242. (New) The array of claim 3223, wherein said non-radioactive chemical label is quantifiable in or from a fluid or solution, said quantity being proportional to the amount or quantity of said label or labels.

Claim 3243. (New) The array of claim 3223, wherein said non-porous solid support is transparent or translucent, and said non-radioactive chemical label is quantifiable in or from a fluid or solution or in or through said non-porous solid support, said quantity being proportional to the amount or quantity of said label or labels.

Claim 3244. (New) The array of claim 3223, wherein said non-radioactive chemical label comprises a chromagen or a chromagenic compound, a colored dye compound, a fluorogen or a fluorescent compound, a chemiluminescent compound, a chelating compound, an enzyme or an enzymatic compound, a coenzyme, biotin, iminobiotin, a hapten or a ligand.

Claim 3245. (New) The array of claim 3223, wherein a non-radioactive signal from said non-radioactive chemical label is quantifiable or detectable by photometric techniques, spectrophotometric techniques, colorimetric techniques, fluorometric techniques or chemiluminescent techniques.

Claim 3246. (New) A non-porous glass or plastic solid support comprising at least one single-stranded nucleic acid directly or indirectly fixed or immobilized thereto in hybridizable form, wherein when said single-stranded nucleic acid is indirectly fixed or immobilized to said non-porous glass or plastic solid support, said indirect fixation or immobilization is not to a cell fixed *in situ* to said non-porous glass or plastic solid support.

Claim 3247. (New) A non-porous glass or plastic solid support comprising at least one double-stranded nucleic acid directly or indirectly fixed or immobilized thereto, wherein at least one nucleic acid strand of said double-stranded nucleic acid comprises at least one non-radioactive chemical label which is quantifiable or detectable, and wherein when said double-stranded nucleic acid is indirectly fixed or immobilized to said non-porous glass or plastic solid support, said indirect fixation or immobilization is not to a cell fixed *in situ* to said non-porous glass or plastic solid support.

Claim 3248. (New) The non-porous glass or plastic solid support of claim 3246 or 3247, wherein said non-porous glass or plastic solid support comprises a plate, a well or wells, a microtiter well or microtiter wells, depressions, tubes, cuvettes, beads, or a set of said plates, wells, depressions, tubes, cuvettes or beads.

Claim 3249. (New) The non-porous glass or plastic solid support of claim 3246 or 3247, wherein said non-porous solid support comprises more than one surface.

Claim 3250. (New) The non-porous glass or plastic solid support of claim 3246 or 3247, comprising reactive sites or binding sites thereon, wherein said nucleic acid is fixed or immobilized to one of said reactive sites or binding sites.

Claim 3251. (New) The non-porous glass or plastic solid support of claim 3250, wherein said reactive sites or binding sites comprise one or more amines, hydroxyls or epoxides.

Claim 3252. (New) The non-porous glass or plastic solid support of claim 3246 or 3247, wherein said non-porous glass or plastic solid support has been treated with a surface treatment agent, a blocking agent, or both.

Claim 3253. (New) The non-porous glass or plastic solid support of claim 3252, wherein said surface treatment agent comprises an amine providing compound, an epoxy glue or solution, an acid solution or ammonium acetate.

Claim 3254. (New) The non-porous glass or plastic solid support of claim 3252, wherein said blocking agent comprises Denhardt's solution.

Claim 3255. (New) The non-porous glass or plastic solid support of claim 3246 or 3247, wherein said direct or indirect fixation or immobilization to said non-porous solid support is covalent

Claim 3256. (New) The non-porous glass or plastic solid support of claim 3246 or 3247, wherein said direct or indirect fixation or immobilization to said non-porous solid support is non-covalent.

Claim 3257. (New) The non-porous glass or plastic solid support of claim 3246, wherein said single-stranded nucleic acid is indirectly fixed or immobilized to said non-porous glass or plastic solid support by sandwich hybridization or by hybridization to a complementary nucleic acid strand.

Claim 3258. (New) The non-porous glass or plastic solid support of claim 3247, wherein one strand of said double-stranded nucleic acid is indirectly fixed or immobilized to said non-porous glass or plastic solid support by sandwich hybridization or by hybridization to a complementary nucleic acid strand.

Claim 3259. (New) The non-porous glass or plastic solid support of claim 3246, wherein said nucleic acid or sequence comprises DNA or RNA.

Claim 3260. (New) The non-porous glass or plastic solid support of claim 3247, wherein said nucleic acid or sequence comprises DNA, RNA, or both.

Claim 3261. (New) The non-porous glass or plastic solid support of claim 3246, wherein said nucleic acid comprises a nucleic acid sequence complementary to a nucleic acid sequence of interest sought to be identified, quantified or sequenced.

Claim 3262. (New) The non-porous glass or plastic solid support of claim 3247, wherein one strand of said double-stranded nucleic acid comprises a nucleic acid sequence of interest sought to be identified, quantified or sequenced.

Claim 3263. (New) The non-porous glass or plastic solid support of claim 3246, wherein said single-stranded nucleic acid is unlabeled.

Claim 3264. (New) The non-porous glass or plastic solid support of claim 3246 or 3247, wherein said non-porous glass or plastic solid support is transparent or translucent.

Claim 3265. (New) The non-porous glass or plastic solid support of claim 3247, wherein said non-radioactive chemical label is quantifiable in or from a fluid or solution, said quantity being proportional to the amount or quantity of said label or labels.

Claim 3266. (New) The non-porous glass or plastic solid support of claim 3247, wherein said non-porous glass or plastic solid support is transparent or translucent, and non-radioactive chemical label is quantifiable in or from a fluid or solution or in or through said non-porous glass or plastic solid support, said quantity being proportional to the amount or quantity of said label or labels.

Claim 3267. (New) The non-porous glass or plastic solid support of claim 3246, comprising more than one single-stranded nucleic acids directly or indirectly fixed or immobilized in hybridizable form to said non-porous glass or plastic solid support.

Claim 3268. (New) The non-porous glass or plastic solid support of claim 3247, comprising more than one double-stranded nucleic acids directly or indirectly fixed or immobilized in hybridizable form to said non-porous glass or plastic solid support.

Claim 3269. (New) A set comprising the non-porous glass or plastic solid supports of claim 3246.

Claim 3270. (New) A set comprising the non-porous glass or plastic solid supports of claim 3247.

Claim 3271. (New) A non-porous solid support comprising single-stranded nucleic acid directly or indirectly fixed or immobilized thereto in hybridizable form, wherein when said nucleic acid is indirectly fixed or immobilized to said non-porous solid support, said indirect fixation or immobilization is not to a cell fixed *in situ* to said non-porous solid support.

Claim 3272. (New) A non-porous solid support comprising a single-stranded nucleic acid directly or indirectly fixed or immobilized thereto in hybridizable form, wherein when said nucleic acid is indirectly fixed or immobilized to said non-porous solid support, said indirect fixation or immobilization is not to a cell fixed *in situ* to said non-porous solid support.

Claim 3273. (New) A non-porous solid support comprising nucleic acid directly or indirectly fixed or immobilized thereto in hybridizable form, wherein when said nucleic acid is indirectly fixed or immobilized to said non-porous solid support, said indirect fixation or immobilization is not to a cell fixed *in situ* to said non-porous solid support.

Claim 3274. (New) A non-porous solid support comprising DNA or RNA directly or indirectly fixed or immobilized thereto in hybridizable form, wherein when said DNA or RNA is indirectly fixed or immobilized to said non-porous solid support, said indirect fixation or immobilization is not to a cell fixed *in situ* to said non-porous solid support.

Claim 3275. (New) A non-porous solid support comprising double-stranded nucleic acid fixed or immobilized thereto, wherein at least one nucleic acid strand of said double-stranded nucleic acid comprises at least one non-radioactive chemical label which is quantifiable or detectable, wherein when said nucleic acid is indirectly fixed or immobilized to said non-porous solid support, said indirect fixation or immobilization is not to a cell fixed *in situ* to said non-porous solid support.

Claim 3276. (New) A non-porous solid support comprising a double-stranded nucleic acid fixed or immobilized thereto, wherein at least one nucleic acid strand of said double-stranded nucleic acid comprises at least one non-radioactive chemical label which is quantifiable or detectable, wherein when said nucleic acid is indirectly fixed or immobilized to said non-porous solid support, said indirect fixation or immobilization is not to a cell fixed *in situ* to said non-porous solid support.

Claim 3277. (New) The non-porous solid support of claim 3271, 3272, 3273, 3274, 3275, or 3276, wherein said non-porous solid support comprises glass or plastic.

Claim 3278. (New) The non-porous solid support of claim 3271, 3272, 3273, 3274, 3275, or 3276, wherein said non-porous solid support comprises more than one surface.

Claim 3279. (New) A system comprising a non-porous solid support and DNA or RNA directly or indirectly fixed or immobilized thereto in hybridizable form, wherein when said DNA or RNA is indirectly fixed or immobilized to said non-porous solid support, said indirect fixation or immobilization is not to a cell fixed *in situ* to said non-porous solid support.

Claim 3280. (New) A system comprising a non-porous solid support and nucleic acid directly or indirectly fixed or immobilized thereto in hybridizable form, wherein when said nucleic acid is indirectly fixed or immobilized to said non-porous solid support, said indirect fixation or immobilization is not to a cell fixed *in situ* to said non-porous solid support.



Claim 3281. (New) A system comprising a non-porous solid support and double-stranded nucleic acid fixed or immobilized thereto, wherein at least one nucleic acid strand of said double-stranded nucleic acid comprises at least one non-radioactive chemical label which is quantifiable or detectable, and wherein when said nucleic acid is indirectly fixed or immobilized to said non-porous solid support, said indirect fixation or immobilization is not to a cell fixed *in situ* to said non-porous solid support.

Claim 3282. (New) A system comprising a non-porous solid support and a double-stranded nucleic acid fixed or immobilized thereto, wherein at least one nucleic acid strand of said double-stranded nucleic acid comprises at least one non-radioactive chemical label which is quantifiable or detectable, and wherein when said nucleic acid is indirectly fixed or immobilized to said non-porous solid support, said indirect fixation or immobilization is not to a cell fixed *in situ* to said non-porous solid support.

Claim 3283. (New) The system of claim 3279, 3280, 3281 or 3282, wherein said non-porous solid support comprises glass or plastic.

Claim 3284. (New) A non-porous solid support comprising nucleic acid directly fixed or immobilized thereto in hybridizable form.

Claim 3285. (New) A non-porous solid support comprising a nucleic acid directly fixed or immobilized thereto in hybridizable form.

Claim 3286. (New) A non-porous solid support comprising DNA or RNA directly fixed or immobilized thereto in hybridizable form.

\* \* \* \* \*

This Page Is Inserted by IFW Operations  
and is not a part of the Official Record

## **BEST AVAILABLE IMAGES**

Defective images within this document are accurate representations of the original documents submitted by the applicant.

Defects in the images may include (but are not limited to):

- BLACK BORDERS
- TEXT CUT OFF AT TOP, BOTTOM OR SIDES
- FADED TEXT
- ILLEGIBLE TEXT
- SKEWED/SLANTED IMAGES
- COLORED PHOTOS
- BLACK OR VERY BLACK AND WHITE DARK PHOTOS
- GRAY SCALE DOCUMENTS

**IMAGES ARE BEST AVAILABLE COPY.**

**As rescanning documents *will not* correct images,  
please do not report the images to the  
Image Problem Mailbox.**

### REMARKS

Reconsideration of this application is respectfully requested.

In the complete listing of the claims provided above, the previously pending claims 2161-3143 have been canceled in favor of new claims 3144-3286.

Accordingly, new claims 3144-3286 are being presented for examination under merits, and these new claims represent the only set of claims pending in this application.

Applicants' attorney would like to acknowledge with sincere appreciation the time and courtesy extended by Dr. Ardin H. Marschel at the May 20, 2004 interview attended by the assignee's representatives, Gene C. Rzulicho, Esq. and the undersigned attorney.

#### **I. New Claims**

##### **A. *Language Directed to Indirect Fixation (in situ)***

As just indicated above, new claims 3144-3286 have been added in place of the former (now canceled) and previously pending claims 2161-3143. In the case of independent claims, 3144, 3145, 3172, 3173, 3198, 3199, 3222, 3223, 3246, 3247, 3271-3276, and 3279-3282, the end of each claim has been drafted to recite "*wherein when nucleic acid is indirectly fixed or immobilized to said non-porous solid support, said indirect fixation or immobilization is not an in situ technique where a cell or cells are fixed to said non-porous solid support.*" The foregoing language has been included in light of the Stuart document (U.S. 4,732,847) provided by the Examiner at the April 1, 2004 interview, and discussed at the May 20, 2004 interview. Support for the italicized recitation just given is found in the specification on page 10, first full paragraph. In the paragraph, Applicants disclose:

In accordance with the practice of this invention, analytes in a biological sample are preferably denatured into single-stranded form, and then directly fixed to a suitable solid support. Alternatively, the analyte

may be directly fixed to the support in double-stranded form, and then denatured. ***The present invention also encompasses indirect fixation of the analyte, such as in in situ techniques where the cell is fixed to the support*** and sandwich hybridization techniques where the analyte is hybridized to a polynucleotide sequence that is fixed to the solid support. [emphasis added]

The language added to the new independent claims can be tracked to the just-quoted disclosure (page 10, first full paragraph) as follows:

RECITATION IN NEW INDEPENDENT CLAIMS ABOVE	LANGUAGE IN SPECIFICATION (PAGE 10, 1ST ¶)
wherein when said nucleic acid is <b><i>indirectly fixed or immobilized</i></b> to said non-porous solid support,	The present invention also encompasses <b><i>indirect fixation</i></b> of the analyte . . .
said indirect fixation or immobilization is <b><i>not to a cell fixed in situ to said non-porous solid support</i></b>	<b><i>such as in <u>in situ</u> techniques where the cell is fixed to the support</i></b> and sandwich hybridization techniques where the analyte is fixed to the solid support

It should be noted that at the May 20, 2004 interview a close form of the above recitation was presented to the Examiner in a proposed claim. After some discussion with the Examiner, the proposed claim was revised at the interview leading to the present language now recited in the new independent claims above.

***B. Reduction in Number of Claims***

In drafting and presenting new claims 3144-3286, Applicants are also seeking to reduce the number of claims in their application. Although the number of claims has been substantially reduced, the subject matter of the new claims can be tracked to the former claims 2161-3143. Listed in the table below are some tracking changes between the two sets of claims.

New Claim	Former Claim	Description of Change (if any)
3144	2161	substitution of "at least one" in new claim 3144; addition of "directly or indirectly" in new claim 3144; addition of " <i>in situ</i> " language in new claim 3144
3145	2384	deletion of "reactive site(s) or binding site(s) in new claim 3145; addition of "directly or indirectly" in new claim 3145; deletion of "non-radioactive signalling moiety in new claim 3145; addition of " <i>in situ</i> " language in new claim
3146	2163/2168	
3147	2164/2166	
3148	2175	
3149	2176/2203	
3150	2186/2191/2192	"epoxides" in new claim supported by "coating solution comprises . . . epoxy glue or solution" in former claim 2191
3151	2178/2194	
3152	2179	
3153	2195	
3154	2197/2200	
3155	2198/2201	
3156	2202	See also original claim 25 ("said polynucleotide sequence is hybridized to a polynucleotide or oligonucleotide probe")
3157	<i>ibid.</i>	<i>ibid.</i>
3158	2204	
3159	2425	
3160	2205	
3161	2426	
3162	2211	See also original claim 24 ("A non-porous solid support having directly fixed thereto a polynucleotide sequence in hybridizable form"); see also original claim 25
3163	2267	
3164	2213	

New Claim	Former Claim	Description of Change (if any)
3165	2213/2267	
3166	2236/2255	
3167	2265	
3168	2271	
3169	2492	Note that new claim 3169 recites "more than one double-stranded nucleic acid" and former claim 2492 recited "various double-stranded nucleic acids"
3170	2268	
3171	2489	
3172	2494	deletion of "reactive site(s) or binding site(s) in new claim addition of "directly or indirectly" in new claim addition of " <i>in situ</i> " language in new claim
3173	2605	<i>ibid.</i>
3174	2607/2612	
3175	2608/2611	
3176	2619	
3177		"reactive site(s) or binding site(s)" are recited in former claim 2605 "nucleic acid fixed or immobilized to said reactive site(s) or binding site(s) also recited in former claim 2605
3178	2628/2633/2634	"epoxides" in new claim supported by "coating solution comprises . . . epoxy glue or solution" in former claim 2633
3179	2620/2636	
3180	2621	
3181	2637	
3182	2639/2642	
3183	2640/2643	
3184	2644	See also original claim 25 ("said polynucleotide sequence is hybridized to a polynucleotide or oligonucleotide probe")
3185	<i>ibid.</i>	<i>ibid.</i>
3186	2536	
3187	2646	
3188	2537	
3189	2647	

New Claim	Former Claim	Description of Change (if any)
3190	2543	See also original claim 24 ("A non-porous solid support having directly fixed thereto a polynucleotide sequence in hybridizable form"); see also original claim 25
3191	2599	
3192	2655	
3193	2599/2655	
3194	2678/2685	
3195	2707	
3196	2603	Note that new claim 3196 recites "more than one single-stranded nucleic acid" and former claim 2603 recited "various single-stranded nucleic acids"
3197	2713	Note that new claim 3197 recites "more than one double-stranded nucleic acid" and former claim 2713 recited "various double-stranded nucleic acids"
3198	2715	deletion of "reactive site(s) or binding site(s) in new claim addition of "directly or indirectly" in new claim addition of " <i>in situ</i> " language in new claim
3199	2825	deletion of "reactive site(s) or binding site(s) in new claim 3198 addition of "directly or indirectly" in new claim addition of " <i>in situ</i> " language in new claim
3200	2717/2722	
3201	2718/2721	
3202	2729	
3203	2715/2825	"reactive site(s) or binding site(s)" are recited in former claims 2715/2825 "nucleic acid fixed or immobilized to said reactive site(s) or binding site(s) also recited in former claims 2715/2825
3204	2739/2744/2745	"epoxides" in new claim supported by "coating solution comprises . . . epoxy glue or solution" in former claim 2744
3205	2731/2747	
3206	2732	

New Claim	Former Claim	Description of Change (if any)
3207	2748	
3208	2750/2753	
3209	2751/2754	
3210	2755	See also original claim 24 ("A non-porous solid support having directly fixed thereto a polynucleotide sequence in hybridizable form"); see also original claim 25
3211	2864	<i>ibid.</i>
3212	2757	
3213	2866	
3214	2758	
3215	2867	
3216	2764	See also original claim 24 ("A non-porous solid support having directly fixed thereto a polynucleotide sequence in hybridizable form"); see also original claim 25
3217	2820	
3218	2766	
3219	2875	
3220	2789/2791	
3221	2818	
3222	2933	change from "nucleic strands or sequences thereof" in former claim 2933 to "single-stranded nucleic acids" addition of "directly or indirectly" in new claim addition of " <i>in situ</i> " language in new claim
3223	2933/2969	<i>ibid.</i>
3224	2935/2938	
3225	2936/2937	
3226	2943	
3227	2948/2949/2953	"epoxides" in new claim supported by "coating solution comprises . . . epoxy glue or solution" in former claim 2953
3228	2944/2954	
3229	2945	
3230	2955	
3231	2957/2960	
3232	2958/2961	



New Claim	Former Claim	Description of Change (if any)
3233	2962	See also original claim 24 ("A non-porous solid support having directly fixed thereto a polynucleotide sequence in hybridizable form"); see also original claim 25
3234	<i>ibid.</i>	<i>ibid.</i>
3235	2963	
3236	<i>ibid.</i>	
3237	2964	
3238	<i>ibid.</i>	
3239	2968	
3240	2970	See also original claim 24 ("A non-porous solid support having directly fixed thereto a polynucleotide sequence in hybridizable form"); see also original claim 25
3241	3026	
3242	2972	
3243	2972/3026	
3244	3018/2995	
3245	3024	
3246	3030	addition of "non-porous" in new claim 3246 addition of "directly or indirectly" in new claim addition of " <i>in situ</i> " language in new claim
3247	3030/3079	<i>ibid.</i>
3248	3032	
3249	3043	
3250	3043/3044	
3251	3054/3059/3060	"epoxides" in new claim supported by "coating solution comprises . . . epoxy glue or solution" in former claim 3059
3252	3046/3062	
3253	3047	
3254	3063	
3255	3065/3068	
3256	3066/3069	

New Claim	Former Claim	Description of Change (if any)
3257	3070	See also original claim 24 ("A non-porous solid support having directly fixed thereto a polynucleotide sequence in hybridizable form"); see also original claim 25
3258	<i>ibid.</i>	<i>ibid.</i>
3259	3072	
3260	<i>ibid.</i>	
3261	3074	
3262	<i>ibid.</i>	
3263	3080	
3264	3138	
3265	3082	
3266	3082/3138	
3267	3142	Note that new claim 3267 recites "more than one single-stranded nucleic acid" and former claim 3142 recited "various nucleic acids"
3268	3079	
3269	3139	
3270	<i>ibid.</i>	
3271	2161	deletion of "a" before "nucleic acid" in new claim 3271 addition of " <i>in situ</i> " language in new claim
3272	2161	deletion of "at least one" in new claim 3272 addition of " <i>in situ</i> " language in new claim
3273	2161	deletion of "at least one" in new claim 3272 addition of " <i>in situ</i> " language in new claim
3274	2161	deletion of "at least one" in new claim 3274 addition of "DNA or RNA" in new claim 3274 addition of " <i>in situ</i> " language in new claim
3275	2384	deletion of "reactive site(s) or binding site(s) in new claim 3275 addition of " <i>in situ</i> " language in new claim

New Claim	Former Claim	Description of Change (if any)
3276	2384	deletion of "at least one" in new claim 3276 deletion of "reactive site(s) or binding site(s) in new claim 3276 addition of " <i>in situ</i> " language in new claim
3277	2163/2168	
3278	2175	
3279	2494	deletion of "reactive site(s) or binding site(s) in new claim 3279 addition of "DNA or RNA" in new claim 3279 addition of " <i>in situ</i> " language in new claim
3280	2494	deletion of "reactive site(s) or binding site(s) in new claim 3280 addition of " <i>in situ</i> " language in new claim
3281	2605	deletion of "reactive site(s) or binding site(s) in new claim 3281 addition of " <i>in situ</i> " language in new claim 3281
3282	2605	deletion of "reactive site(s) or binding site(s) in new claim 3282 addition of " <i>in situ</i> " language in new claim 3282
3283	2496/2501	
3284	2161	deletion of "a single-stranded" in new claim 3284 addition of "directly" in new claim 3284
3285	2161	deletion of "a single-stranded" in new claim 3284 addition of "directly" in new claim 3285
3286	2161	deletion of "a single-stranded nucleic acid" in new claim 3284 addition of "directly" in new claim 3285

**C. Defining Glass or Plastic Solid Support as "Non-Porous"**

The instant Office Action (page 4, last paragraph) indicated that:

". . . Several citations as filed are directed to glass or plastic solid supports but none of them support instant claim 3030. . . . Additionally, these solid supports are disclosed as being non-porous but such a non-porous limitation is lacking in claim 3030. It is noted that glass and plastic are well known to be optionally porous as well as non-porous, if desired."

In acknowledging the Examiner's position on this point, Applicants have presented new claims 3246-3270 above, including independent claims 3246 and 3247. Both of these claims recite "[a] *non-porous* glass or plastic solid support comprising at least one nucleic acid directly or indirectly fixed or immobilized thereto, . . ." Support for the insertion of the term "non-porous" before "glass or plastic solid support" is found throughout the specification, including, for example, page 10, lines 18-19 ("it is preferred that the *solid support* to which the analyte is fixed be *non-porous* and transparent, such as *glass*, or alternatively, *plastic*, . . ."); and page 15, lines 8-10 ("Specifically referred to therein are methods for fixing the analyte to a *non-porous* solid support, . . ."); see also original claim 5 ("characterized in that solid support is *non-porous*") and original claim 24 ("A *non-porous* solid support having directly fixed thereto a polynucleotide sequence in hybridizable form").

**D. Replacement of Parenthetical "(s)" To Describe Reactive/Binding Sites Or Plates**

Although not rejected in the instant Office Action, Applicants have eliminated in several instances the parenthetical "(s)" that were used to describe the "reactive

sites or binding sites" or the "plates" recited in the former and now canceled claims.<sup>1</sup> Thus, the new claims 3144-3286 lack any such notation. It is believed that the lack of the parenthetical "(s)"s in the new claims renders the language clearer by describing more precisely the various recited elements.

***E. Language in Other New Claims Recite "Directly Fixed or Immobilized" in Distinction to in situ Hybridization***

Other new claims 3284-3286 recite that "nucleic acid," "a nucleic acid," or "DNA or RNA" are directly fixed or immobilized thereto in hybridizable form. Applicants note that direct fixation or immobilization of nucleic acid to a non-porous solid support is distinguished from indirect fixation, such as *in situ* hybridization. See discussion above in I. New Claims A. Language Directed to Indirect Fixation (*in situ*), pages 26-27. See also the first full paragraph on page 10 in the specification.

The above amendments to the claims are necessary and should be entered. As explained above, with respect to new independent claims, the amendments regarding *in situ* as an indirect fixation are made in response to the document, Stuart et al. (US 4,732,847) that the Examiner provided to Applicants' representatives at the April 1, 2004 interview. With respect to the other new claims, 3246-3270, "non-porous" is used to describe the glass or plastic solid support, largely in response to a point newly raised in the new matter rejection set forth in the instant April 7, 2004 Office Action. With respect to the removal of the parenthetical "(s)" notation in the claims,

---

<sup>1</sup> The former claims containing the parenthetical "(s)" included 2176, 2177, 2186, 2190, 2192, 2203, 2273, 2288, 2297, 2301, 2303, 2314, 2384, 2394, 2407, 2494, 2504, 2509, 2522, 2524, 2535, 2605, 2609, 2615, 2628, 2632, 2715, 2725, 2730, 2739, 2743, 2745, 2756, 2825, 2852, 2854, 2933, 2843, 2949, 2952, 3044-3045, 3054, 3058, 3060 and 3071.

these amendments probably have no affect on the patentability of the claims, and they are offered merely for the sake of clarity and readability. No new issues are believed to be raised by the above claim amendments, nor do the amendments require further consideration and/or search. Furthermore, the above claim amendments do not raise any issue of new matter. Lastly, the amendments will place the application in better form for appeal by materially reducing or simplifying the issues for appeal.

Entry of the new claims 3144-3286 is respectfully requested.

## **II. New Matter Rejection**

Claims 2161-3143 stand rejected under 35 U.S.C. §112, first paragraph, as allegedly failing to comply with the written description requirement. On pages 2-3, the April 7, 2004 Office Action states:

Consideration of the entirety of the instant application as filed has revealed that several citations therein are directed to non-porous solid supports with nucleic acids. [1] These citations as discussed below do not give written basis for the generic non-porous solid support embodiments as instantly claimed wherein nucleic acids are fixed or immobilized in hybridizable form. [2] A citation of non-porous solid support is present on page 10, lines 17-22, wherein the non-porous solid supports are also required to be transparent and also only fixation is cited thereto, rather than immobilization also as instantly claimed. [3] On page 14, lines 26-29, a non-porous solid support is cited but only with a directly fixed polynucleotide in hybridizable form again not supporting the newly submitted claims. [4] On page 15, lines 13-15, non-porous supports are also required to be translucent or transparent. [5] On page 22, last 4 lines, the non-porous solid supports are limited to being siliceous and also provided with a treatment of a coating of epoxy resin. [6] On page 23, lines 12-16 the non-porous solid support is

limited via direct fixation of a polynucleotide. [7] In claim 5 as originally filed in dependence from claim 1 causes the embodiments therein to be limited to fixed polynucleotides to a non-porous support without additionally an immobilization option. [8] This is the same set of limitations present in claim 24 as originally filed. [9] No other non-porous embodiments have been found and filed to support the broad generic embodiments wherein a generic non-porous support is either fixed (no direct limitation, for example) to a nucleic acid. This rejection is necessitated by amendment.

[10] Additionally, certain claims such as claim 2494 and many others cite reactive sites or binding sites on the non-porous solid support embodiments. [11] Consideration of the entirety of the instant disclosure as filed has failed to reveal such generic reactive or binding sites disclosure. [12] It is noted that certain chemical treatments of solid supports are disclosed, however, reactions supported by these treatments are covalent in nature and not generic without any covalent limitation. [13] Additionally, the only binding practice separate from reactive covalent attachment practice as filed is that of hybridization between nucleic acid polymers. These limitations therefore are NEW MATTER as being broader and more generic than such sites as disclosed as originally filed. This rejection is necessitated by amendment.

At the end of page 3 and continuing through the first full paragraph on page 5, the Office Action goes on to state further:

[14] Consideration of array claim 2715 reveals that it is directed to a generic non-porous solid support with various single-stranded nucleic acids or sequences fixed or immobilized thereto. [15] Reiterated consideration of the entirety of the instant disclosure reveals that the practice of "various denatured analytes" with a solid support is disclosed

only on page 16, lines 9-14, as being present for example in an array of depressions or wells. [16] A generic solid support is not disclosed as filed nor a non-porous generic support of this type with "various single-stranded nucleic acids or sequences" as now present in claim 2715 and others via dependence, such as claim 2825 and claims dependent therefrom. [17] Review of instant claim 2933 directed to wells or depressions with said "various..." limitations reveals that the nucleic acid strands or sequences are either fixed or immobilized whereas in contrast said page 16 citation only cites fixation practice. Thus claims 2933 also contains NEW MATTER for this reason. This rejection is necessitated by amendment which set forth such "various..." limitations.

[18] NEW MATTER has also been added in newly submitted claims via independent claim 3030. Several citations as filed are directed to glass or plastic solid supports but none of them support instant claim 3030. [19] For example, on page 10, lines 17-22, glass or plastic solid supports are set forth but only with fixed, and not immobilized nucleic acids or sequences. [20] Additionally, these solid supports are disclosed as being non-porous but such a non-porous limitation is lacking in claim 3030. [21] It is noted that glass and plastic are well known to be optionally porous as well as non-porous, if desired. [22] On page 15, lines 16-20, glass is cited as being only "fixed" to a denatured single-stranded "DNA" sequences which again fails to support instant claim 3030 as to written basis. [23] Glass plates are cited on page 16, lines 8-14, but limited to containing well or depressions and lacking in generic support of instant claim 3030. [24] On pages 16-17 Example 2 cites a glass surface but it is specifically treated and in the form of glass tubes. [25] In Example 3 again the glass is specifically



treated with DNA immobilized. [26] In Example 5 on pages 20-21 a probe is immobilized to a non-porous plastic surface. Claim 3030 lacks any non-porous limitation. [27] On page 22, line 1, DDA-coated polystyrene is cited but this also is not supportive of the generic instant claim 3030. [28] In Example 7 a microtiter well is cited but only with polynucleotide fixation thereto again not supportive of instant claim 3030. [29] Original claim 7 cites glass or plastic, however, this claim depends from claim 5 which also has a non-porous limitation which is not present in instant claim 3030. This rejection is necessitated by amendment.

Applicants argue the previously set forth rejections, however, are deemed moot due to new rejections as set forth above as necessitated by amendment.

Lastly, beginning with the last paragraph on page 5 and continuing through the first two lines on page 6, the Office Action states:

[30] The Declaration of Dr. Dollie M. W. Kirtikar has been considered. [31] It describes experimental data and embodiments which are apparently separate from the instant disclosure as filed. This rejection is based on a lack of written description of specific claim limitations as filed. [32] The additional information of experiments performed by Dr. Kirtikar are non-persuasive as these were not disclosed as filed and therefore fail to remedy the lack of written basis for limitations of the instant claims. [33] For specific example, item #7 of the Declaration describes Exhibits, none of which are set forth in the instant application. [34] Within these exhibits the first Exhibit 2 indicates the usage of preprinted slides including with slots. No such slotted slides have been pointed to as being instantly disclosed as filed and therefore fails to be persuasive. [35] It is appreciated that the

experimental material cited in said Declaration is consistent with the instant application, however, this lacks persuasiveness as only the written description as filed must be relied on for the purposes of this rejection.

The new matter rejection is respectfully traversed.

## II. Response to New Matter Rejection

In order to insure that each and every point is fully addressed, Applicants' attorney has inserted bold bracketed numbers before each of the points set forth in the new matter rejection above. The remarks and information below are directed to each of the 35 bold bracketed numbers referenced in the Office Action rejection. Furthermore, a review of the Office Action strongly suggests that the principal issues raised in the new matter rejection can be grouped as follows:

- |    |                              |                          |
|----|------------------------------|--------------------------|
| A. | fixation/immobilization      | Points [1] through [9]   |
| B. | reactive sites/binding sites | Points [10] through [13] |
| C. | various nucleic acids        | Points [14] through [17] |
| D. | non-porous glass/plastic     | Points [18] through [29] |
| E. | Dr. Kirtikar's submission    | Points [30] through [35] |

### A. Fixation/Immobilization

[1] In the context of their invention, Applicants use the terms "fixed" and "immobilized" synonymously and equivalently throughout the specification, the originally filed claims and the abstract. No distinction or difference is ever made in the specification between these two terms with respect to the fixation or immobilization of nucleic acids to a non-porous solid support.

To begin with, the term "**fixed**" and its variants are disclosed no less than 26 times in the specification:

**26 Citations in the Specification for "Fixed" and Variants**

1. Page 10, lines 4-5 ("**fixed** in hybridizable form to a solid support");
2. Page 10, line 9 ("**directly fixed**");
3. Page 10, line 10 ("**directly fixed**");
4. Page 10, line 13 ("**indirect fixation**");
5. Page 10, lines 16-17 ("polynucleotide sequence that is **fixed** to the solid support");
6. Page 10, lines 18-19 ("the solid support to which the analyte is **fixed**");
7. Page 10, line 27 ("**easily fixed** to the solid support");
8. Page 10, line 28 ("to easily **fix** the analyte to a transparent substrate");
9. Page 10, line 33 ("**fixed** single-stranded analytes");
10. Page 13, line 1 ("the **fixed** probe-analyte hybrid");
11. Page 14, lines 2-3 ("the solid support to which the analyte is **fixed**");
12. Page 14, lines 28-29 ("a non-porous solid support to which a polynucleotide is directly **fixed** in hybridizable form.");
13. Page 14, line 30 ("**fixed** sequence");
14. Page 15, lines 9-10 ("**fixing** the analyte to a non-porous solid support");
15. Page 15, lines 16-17 ("To effect easy **fixing** of a denatured single-stranded DNA sequence to a glass support, one exemplary "**fixing**");
16. Page 16, lines 12-13 ("the single-stranded analytes being **fixed** to the surfaces");
17. Page 20, lines 25-26 ("the adherence or **fixing** of DNA to a polystyrene surface is improved by treating the surface");
18. Page 20, lines 32-33 ("the **fixing** or uniformity of the plastic surface for **fixing** DNA");
19. Page 20, lines 35-36 ("the **fixing** of DNA to a plastic surface");
20. Page 21, lines 30-31 ("enabling **fixation** of single-stranded analyte to a solid support");

21. Page 22, lines 34-36 ("for **fixing** or immobilization of DNA to non-porous siliceous solid supports");
22. Page 23, lines 14-16 ("**fixing** the polynucleotide analyte sequence directly to a non-porous solid support");
23. Page 23, lines 30-31 ("Single-stranded analyte DNA is now **fixed** to the wells")
24. Page 23, lines 32-33 ("**fix** the analyte DNA to the well");
25. Page 24, line 13 ("To hybridize the **fixed** analyte with a probe,"); and
26. Page 25, lines 4-5 ("Detection of the **fixed** hybridized analyte-probe").

Likewise, as set forth below, the term "**immobilized**" and its related term "**immobilization**" are disclosed several times in the specification. Set forth below are citations in the specification for "**immobilized**" (total of 7 instances) and "**immobilization**" (1 instance):

**8 Citations in the Specification for "immobilized" and "immobilization"**

1. Page 14, lines 11-12 ("an **immobilized** polynucleotide sequence");
2. Page 15, line 14 ("analyte is **immobilized** on a solid support");
3. Page 16, lines 1-2 ("suitable for **immobilizing** or fixing any negatively charged polyelectrolytes");
4. Page 18, lines 23-25 ("the analyte, phage lambda DNA, was **immobilized** on an activated glass surface");
5. Page 20, lines 18-19 ("when the probe is **immobilized** on a non-porous plastic surface");
6. Page 21, lines 19-21 ("several biotinylated probes, B-adeno-2-DNA and lambda DNA were hybridized to the **immobilized** DNA");
7. Page 21, lines 21-22 ("To one set of **immobilized** DNA, no probe was added");  
and
8. Page 22, lines 34-36 ("for fixing or **immobilization** of DNA to non-porous siliceous solid supports").

Even more significantly, the very phrases, "immobilizing or fixing" and "fixing or immobilization" are disclosed in two separate instances in the specification.

**2 Citations in the Specification where the Phrases "immobilizing or fixing" and "fixing or immobilization" are recited**

1. Page 16, lines 1-2 ("suitable for immobilizing or fixing any negatively charged polyelectrolytes"); and
2. Page 22, lines 34-36 ("for fixing or immobilization of DNA to non-porous siliceous solid supports").

Example 5 found on pages 20 and 21 in the specification is also telling on this issue. For instance, Example 5 begins with the sentence "The advantages of the practices of this invention are also obtainable when the probe is **immobilized** on a non-porous plastic surface (emphasis added)." The very next sentence explains that ". . . it is sometimes desirable to increase the effectiveness or uniformity of the **fixation** by pretreating the plastic surface (emphasis added)."

The second paragraph in Example 5 then refers to "binding" in the same context as "fixing":

Because polystyrene from various batches or sources exhibits different **binding** capacities, the adherence or **fixing** of DNA to a polystyrene surface is improved by treating the surface with an amino-substituted hydrophobic polymer or material. Previous experiments demonstrated that addition of dodecylamine (DDA) to polystyrene resulted in a uniform **binding** coefficient of polystyrene plates of different batches. Another technique for improving the **fixing** or uniformity of the plastic surface for **fixing** DNA involves treatment of the surface with polylysine (PPL).

The third paragraph in Example 5 also refers to "fixing" and "bound":

In tests involving the **fixing** of DNA to a plastic surface, biotinylated DNA (b-DNA) was denatured and aliquoted into Dynatech Immulon IITM removeable wells. Samples were allowed to dry onto the plastic surface at 37°C. The amount of **bound** b-DNA was determined . . .

The fourth paragraph in Example 5 then uses interchangeably "bound" and "immobilized":

In a further example of the method, denatured adenovirus 2 DNA, the analyte, was **bound** to polystyrene plates, as described above. After blocking with Denhardt's formamide blocking buffer, several biotinylated probes, B-adeno-2-DNA and lambda DNA were hybridized to the **immobilized** DNA. . .

Thus, in Example 5, it is clear that through the use of "binding" and "bound," Applicants used the terms "fix" and "fixing," and "immobilize" and "immobilization" synonymously in describing their invention and its embodiments.

Beyond the numerous citations listed above, the terms "**fixing**" and "**fixed**" are recited in four originally filed claims (1, 9, 10 and 24):

**4 Originally Filed Claims Recite "Fixing," "Fixation" and "Fixed"**

1. Original claim 1 ("**fixing** said polynucleotide sequence to a solid support in hybridizable form");
2. Original claim 9 ("said polynucleotide sequence is directly **fixed** to said solid support");
3. Original claim 10 ("said polynucleotide sequence is **fixed** to said solid support in single stranded form"); and
4. Original claim 24 ("A non-porous solid support having directly **fixed** thereto a polynucleotide sequence in hybridizable form").

The term "immobilized" is also disclosed in two originally filed claims (20 and 23):

**2 Originally Filed Claims Recite "Immobilized"**

1. Original claim 20 ("(i) an **immobilized** polynucleotide sequence hybridized to a polynucleotide or oligonucleotide probe,"); and
2. Original claim 23 ("(i) an **immobilized** polynucleotide sequence hybridized to a polynucleotide or oligonucleotide probe,").

The term "fixing" is also disclosed in the originally filed abstract.

**The Original Abstract Recites "Fixing"**

Polynucleotide sequences in a sample of biological or nonbiological material are detected by a method involving **fixing** of the sequences on a solid support . . .

The terms "**fixing**," "**fixation**" and "**fixed**" are also recited in various issued claims in U.S. Patent No. 4,994,373.

**U.S. Patent No. 4,994,373 Recites Three Variations of "Fix"**

Claim 1 ("**fixing** said polynucleotide sequence")

Claim 17 ("said polynucleotide sequence **fixed** thereto in hybridizable form")

Claim 20 ("to facilitate **fixing** of the polynucleotide sequence")

Claim 21 ("to facilitate **fixation** of the polynucleotide sequence")

Claim 22 ("to facilitate **fixation** of the polynucleotide sequence")

Claim 23 ("said polynucleotide sequence is **fixed** . . .")

Claim 24 ("said polynucleotide sequence in double-stranded form is denature and **fixed**")

Claim 26 ("a cell or cellular material is directly **fixed** to said solid support, and polynucleotide sequences within said material are hybridized to polynucleotide or oligonucleotide probes in situ")

Because the specification makes no distinction between "fixing" and "immobilizing" or between "fixed" and "immobilized," it follows that to limit the claims to "fixing" and "fixed" is forcing an unwarranted interpretation of these terms that is neither disclosed nor supported in the disclosure, or even in the art of record. More importantly, the claimed "generic" solid support wherein nucleic acids are fixed or immobilized in hybridizable form is disclosed in at least two instances in the specification: page 14, lines 27-29 ("the present invention provides for the novel product of a **non-porous solid support** to which a **polynucleotide is directly fixed in hybridizable form**"); and original claim 24 ("A **non-porous solid support** having **directly fixed** thereto a **polynucleotide sequence in hybridizable form**").

Furthermore, it should not be overlooked that the phrase "fixed or immobilized" has also been used in the scientific and patent literature to describe the attachment of nucleic acids, polynucleotides and nucleic acid sequences to solid support.

#### **The Scientific Literature Makes No Distinction Between "Fixed" and "Immobilized"**

1. In a section of Nucleic Acid Hybridization Essential Techniques [edited by J. Ross, John Wiley & Sons, Chichester, 1998], B. M. Harvey discloses:

##### **Introduction**

Filter hybridization involves **immobilizing** single-stranded target DNA or RNA on a membrane and then incubating the membrane with a probe for the nucleic acid of interest [1]. Filter hybridization is used primarily to detect gel-fractionated nucleic acids following membrane transfer. Transfers of gel-fractionated DNA or RNA are referred to as Southern or northern blots, respectively [2-4].

After gel electrophoresis and transfer, the nucleic acid is "**fixed**" or **immobilized** by heating the membrane or exposing it to UV light. The nature of probe-membrane binding is incompletely understood but is



believed to be hydrophobic. The hybridization process itself is divided into three steps: pre-hybridization, hybridization, and stringency washing. In pre-hybridization, the blot is incubated with a solution designed to "block" non-specific binding of the probe to the membrane. The same buffer is often used also for step two. No probe is present during step one. In step two the membrane is incubated with single-stranded probe in a hybridization buffer. The membrane-bound target cannot anneal with itself but will hybridize to the probe. Step three is a washing procedure designed to remove unhybridized probe and unstable (poorly matched) hybrids from the membrane. Adequate washing under the most stringent conditions possible lowers background.

Guidelines on how to choose a membrane, optimize target-to-membrane transfer, and fix the membrane are outlined below. No single set of conditions or criteria is optimal for all membranes, targets, and probes. The protocols are guidelines applicable for most experiments, but you should consult Chapter 1 for additional information when troubleshooting is required.<sup>2</sup>

2. In the abstract to a recent article by Taylor et al. ["Impact of surface chemistry and blocking strategies on DNA microarrays," Nucleic Acids Research, Vol. 31, No. 16 e87 (2003)], the authors disclose:

**ABSTRACT**

The surfaces and **immobilization** chemistries of DNA microarrays are the foundation for high quality gene expression data. Four surface modification chemistries, poly-L-lysine (PLL), 3-glycidoxypropyl-

---

<sup>2</sup> Copy attached as Exhibit A.

trimethoxysilane (GPS), DAB-AM-poly(propyleminime hexadecaamine) dendrimer (DAB) and 3-aminopropyltrimethoxysilane (APS), were evaluated using cDNA and oligonucleotide sub-arrays. Two un-silanized glass surfaces, RCA-cleaned and immersed in Tris-EDTA buffer were also studied. DNA on amine-modified surfaces was **fixed** by UV light (90 mJ/cm<sup>2</sup>), while DNA on GPS-modified surfaces was **immobilized** by covalent coupling.<sup>3</sup>

3. In the abstract to a 2001 article ["DNA microarray synthesis by using PDMS molecular stamp (II) - Oligonucleotide on-chip synthesis using PDMS stamp," Science in China Series B (Chemistry), Vol. 44, no. 4], Xiao et al. also use the terms "fixed" and "immobilized" interchangeably to describe the attachment of an array of oligonucleotides to glass slides:

Route B was a contact detritylation, in which one nucleoside was **fixed** on the desired synthesis regions where dimethyloxytrityl (DMT) protecting groups on the 5'-hydroxyl of the support-bound nucleoside were removed by stamping trichloroacetic acid (TCA) distributed on features on a PDMS stamp. Experiments showed that the synthetic yield and the reaction speed of route A were higher than those of route B. It was shown that 20 mer oligonucleotide arrays **immobilized** on the glass slide were successfully synthesized using the PDMS stamps, and the coupling efficiency showed no difference between the PDMA stamping and the conventional synthesis methods.<sup>4</sup>

4. In their 2000 article ["Position-specific release of DNA from a chip by using photothermal denaturation," Sensors and Actuators B, Vol. 64, Issues 1-3, pages 88-

---

<sup>3</sup> Copy attached as Exhibit B.

<sup>4</sup> Copy attached as Exhibit C.

94], Okano et al. also use the terms "fixed" and "immobilized" interchangeably in the context of DNA chips:

A photochemical method to recover specific DNA fragments **fixed** in place on a DNA chip is described. This method uses infrared (IR) laser irradiation to thermally denature and release specific DNA **immobilized** in a specific area of a chip. A 1053-nm IR laser beam with an intensity of 10-100 mW is focussed on the target area at a resolution of 10 m, and the DNA fragments containing different numbers of base pairs (231-799 bp) fixed in place on the DNA chip can be separately recovered. There are enough quantities of recovered DNA fragments that can be amplified by using polymerase chain reaction (PCR). The photothermal method coupled with the DNA chip can therefore be used in highly sensitive purification of DNA and will have many applications in the DNA chip technology.<sup>5</sup>

**At Least One Issued U.S. Patent Also Uses the Terms "Fixed" and "Immobilized" Interchangeably**

Claims have issued reciting "fixed or immobilized" without any distinction: In commonly owned and assigned Engelhardt et al., U.S. 6,221,581 B1 (April 24, 2001), claim 1 recites:

A process for detecting a nucleic acid of interest comprising the steps of:

. . . wherein when said capturing or collecting is carried out with an oligo- or polynucleotide **fixed or immobilized** to a solid support, said oligo- or polynucleotide is substantially incapable of hybridizing with said nucleic acid of interest or portion thereof.

Claim 30 in Engelhardt's '581 Patent also recites:

---

<sup>5</sup> Copy attached as Exhibit D.

A process for detecting a nucleic acid of interest comprising the steps of:

. . . wherein when said capturing or collecting is carried out with an oligo- or polynucleotide **fixed or immobilized** to a solid support, said oligo- or polynucleotide is substantially incapable of hybridizing with said nucleic acid of interest or portion thereof.<sup>6</sup>

Thus, it is very clear that the instantly recited "fixed or immobilized" language is fully supported in Applicants' disclosure as synonymous or equivalent meaning.

[2] That the solid support can be transparent (or translucent) is a preferred embodiment disclosed as such in at least two instances in the specification. See for example, the same cited page 10, lines 18-20 ("**it is preferred** that the solid support to which the analyte is fixed be non-porous and **transparent**"). See also page 14, line 34 ("the support is **preferably transparent or translucent**"). See also page 15, lines 13-15 ("an analyte is immobilized on a solid support, **preferably a non-porous translucent or transparent support**"). Transparency or translucency is not an essential feature of the non-porous solid support in Applicants' claimed invention.

As explained above, fixation is used synonymously with immobilization. In particular, see page 14, lines 27-29 ("the present invention provides for the novel product of a non-porous solid support to which a polynucleotide is directly fixed in hybridizable form"). Even on the same aforementioned page and paragraph, the term "immobilized" is used twice to describe the attachment of the polynucleotide sequence. See also page 14, lines 12-14 ("a device that "contains an **immobilized** polynucleotide sequence hybridized to a polynucleotide or oligonucleotide probe"); and page 14, lines 23-25 ("at least one such device contains the above-described **immobilized** polynucleotide sequence, polynucleotide or oligonucleotide probe").

---

<sup>6</sup> Copy attached as Exhibit E.

[3] Direct fixation to a non-porous solid support of a polynucleotide in hybridizable form is *not* the only "fixation" disclosed in the original specification. As set forth in Chart 7 dated 12/3/02 which was submitted in a December 31, 2002 Communication, three different reactive groups or bindings sites are disclosed in the specification and they include amines, epoxides and hydroxyls. These reactive groups or binding sites follow from the various treatments of plastic and glass described in Applicants' examples and set forth in Chart 8, also dated 12/3/02. Altogether, there are seven treatments listed in Chart 8, of which three treatments are used for plastic, two are used for glass, and two are used for both plastic and glass.

In further detail, dodecadiamine (DDA) is disclosed in Examples 5 and 6 for treating plastic. Plastic treated with polylysine (PPL) and amino-derivatized (6-amino-hexane linked) are described in Examples 5 and 6, respectively. Epoxy glue or solution is disclosed in Example 6 for treating glass and plastic. Likewise, ammonium acetate is disclosed in Example 7 as a treatment for glass and plastic. For glass treatment,  $\gamma$ -aminopropyltriethoxysilane and coating solution are disclosed in Examples 1 and 3, respectively. These seven disclosed examples (Chart 8) for treating the non-porous solid support produce the three different reactive groups or binding sites (Chart 7) used for attaching nucleic acids thereto. One need only look to Applicants' originally filed claims, moreover, to readily understand that direct fixation is but one of the embodiments of their claimed invention. Dependent from original claim 1, original claim 9 recites that "said polynucleotide sequence is directly fixed to said solid support [of claim 1]."

[4] As explained above in [2], transparency or translucency is not an essential feature of the non-porous solid support in Applicants' claimed invention. The citation in the Office Action referring to page 14, lines 26-29, is but one of several instances

where the non-porous solid support is *preferably* transparent or translucent. See page 10, lines 18-20 ("it is **preferred** that the solid support to which the analyte is fixed be non-porous and **transparent**,"); page 14, line 34 ("the support is **preferably transparent or translucent**"); and page 15, lines 13-15 ("an analyte is immobilized on a solid support, **preferably** a non-porous **translucent or transparent support**"). That the non-porous solid support is *preferably* translucent or transparent is also seen in originally filed claims 6 and 26, both of which recite that the [solid] support is "*transparent or translucent*."

[5] This citation (page 22, last 4 lines) is part of Example 6 that begins on the preceding page. As such, the siliceous nature of the solid support and the treatment with an epoxy coating represent preferred embodiments. In fact, just beyond the last four lines on page 22, Applicants disclose "*For example*, treatment of glass or polystyrene surfaces with commercially available epoxy glues, such as a solution of epoxy glue in ethanol [1 percent w/v] serves this purpose." Page 15, lines 6-8 also makes it clear that "[t]he following examples are *illustrative of preferred embodiments* of the method of the present invention").

[6] Again, as explained in [3] above, direct fixation of a polynucleotide to a non-porous solid support is but one of the embodiments of Applicants' claimed invention. See [3] above, citing Examples 1, 3, 5, 6 and 7, and further citing original claim 9. In addition, this citation (pages 23, lines 12-16) is a preferred embodiment that is part of yet another example (in this case, Example 7). The full and complete quotation from the specification (page 23, lines 12-16) is as follows: "**Yet another example** of the method of the present invention, **including fixing** the polynucleotide analyte sequence directly to a non-porous solid support, such as a conventional microtiter well, ").

[7] Applicants are somewhat unclear regarding the relationship between claim 5 as originally filed and the issue of immobilization versus fixation in their claimed invention. As explained earlier (see [1] above), "**fixation**" and "**immobilization**" are synonymous terms with no distinction or difference in meaning. See the several lists of citations provided in [1]. See in particular, page 16, lines 1-2 ("**suitable for immobilizing or fixing any negatively charged polyelectrolytes**"); and page 22, lines 34-36 ("**for fixing or immobilization of DNA to non-porous siliceous solid supports**"), where the terms are used interchangeably in the same phrase or sentence. Furthermore, as explained in [3] and [6] above, Applicants' claimed invention is not at all limited to the direct fixation of polynucleotides and polynucleotide sequences to a non-porous solid support. As explained above, direct fixation is an embodiment of Applicants' claimed invention, and it was originally disclosed as just such an embodiment. Thus, the fact that original claim 5 recites that the method according to claim 1 is "characterized in that said solid support is non-porous" does not negate Applicants' use in their specification of "fixation" and "immobilization" as synonymous terms with no clear distinction or difference in meaning. Furthermore, the language recited in claim 5 comports with the language in the specification, namely, that the solid support is preferably "non-porous." See for example, page 10, lines 18-20 ("**it is preferred that the solid support to which the analyte is fixed be non-porous and transparent,**"); and also page 15, lines 13-15 ("**an analyte is immobilized on a solid support, preferably a non-porous translucent or transparent support**").

[8] Likewise, in the case of claim 24 as originally filed, this language does not limit Applicants' claimed invention at with respect to the fixation or immobilization of nucleic acids or polynucleotide sequences to a non-porous solid support. Original claim 24 broadly recites "[a] non-porous solid support having directly fixed thereto a polynucleotide sequence in hybridizable form." For reasons given above in [1], [3] [6]

and [7], Applicants use the terms "fixation" and "immobilization" synonymously, and direct fixation is merely one of the embodiments whereby Applicants disclose nucleic acids and polynucleotide sequences being fixed or immobilized to a non-porous solid support.

[9] As explained in [1], [3] [6], [7] and [8] above, Applicants' disclosure broadly supports the fixation and immobilization of nucleic acids to a non-porous solid support. As explained, for example, in [1], fixation and immobilization are terms used synonymously and interchangeably throughout Applicants' specification. As explained in [3], direct fixation is but one of the embodiments for Applicants' claimed invention. See also original claim 9, discussed in [1].

**B. Reactive Sites/Binding Sites**

[10] As explained in [3] above, Applicants provide in their examples several forms of treatment to render the non-porous solid support with reactive sites or binding sites. Dependent claims 3149, 3177, 3203, 3226 and 3250 recite that the non-porous solid support comprises "reactive sites or binding sites thereon, wherein said nucleic acid is fixed or immobilized to one of said reactive sites or binding sites."

[11] As discussed in [3], Applicants disclose three different reactive groups or bindings sites which include amines, epoxides and hydroxyls (see Chart 7). Applicants also disclose seven treatments of non-porous solid supports including glass and plastic (see Chart 8), of which three treatments are used for plastic, two are used for glass, and two are used for both plastic and glass. The three reactive groups or binding sites follow from the seven treatments of plastic and glass described in Applicants' examples (see Examples 1, 3, 5, 6 and 7 discussed in [3] above). To state it another way, there are seven disclosed examples (see Chart 8) for treating the non-porous solid support in order to produce the three different



reactive groups or binding sites (see Chart 7) for attaching nucleic acids thereto. Thus, the specification reasonably conveys that Applicants had possession of their claimed subject matter for reactive sites and binding sites. See Ex parte Soreson, 3 USPQ 2d (Bd. Pat. App. & Int'f, 1987) and Ex parte Murray, 9 USPQ 2d (Bd. Pat. App. & Int'f, 1988).

To elaborate further, the specification discloses several treated or activated surfaces that provide the instantly claimed reactive sites or binding sites. For instance, "**treated glass surface**" is described on page 15, last line, through page 16, line 2 ("The resulting **treated glass surface** will now have available alkylamine thereon suitable for immobilizing or fixing any negatively charged polyelectrolytes"). See also, page 16, lines 29-30 ("A **glass surface treated** as described in Example 1 can be employed in the method of the present invention,"). In other instances, "activated glass surface" is disclosed on page 17, lines 14-16 ("Both glucosylated labelled and unlabelled DNA "probe" bound to the **activated glass surface**"); and on page 18, lines 23-25 ("In these tests, the analyte, phage lambda DNA, was immobilized on an **activated glass surface**"). See also page 20, lines 21-22 ("to increase the effectiveness or uniformity of the fixation by **pretreating the plastic surface**"); and page 20, lines 31-34 ("improving the fixing or uniformity of the plastic surface for fixing DNA involves **treatment of the surface** with polylysine (PPL). Also, **DDA-coated polystyrene plates** are disclosed on page 21, last line, through page 22, line 2 ("The labelled, non-biotinylated denatured DNA [2000 ng to 5 ng] was applied to **DDA-coated polystyrene plates**"). Further, 6-aminohexane linked polystyrene and amino-derivitized polystyrene are disclosed on page 22, 2nd full ¶ ("To produce 6-aminohexane linked polystyrene") and ("Amino-derivitized polystyrene"). Later, in Example 6, also page 22, glass and plastic are disclosed as provided by **treatment with a coating of an epoxy resin**. On page 23, lines 1-3, there is disclosed "**treatment of glass or polystyrene surfaces with commercially available epoxy glues**, . . .") Each of these disclosed treatments, treated surfaces and activated surfaces

results in reactive sites or a binding sites for attaching nucleic acid to a non-porous solid support.

[12] Applicants disclose several chemical treatments of solid supports, but the reactions supported by these treatments can be covalent or non-covalent. As explained in both [1] and [11] above, and as set forth in Applicants' Chart 7 dated 12/3/02 and submitted in their December 31, 2002 Communication, three different reactive groups or bindings sites are disclosed in the specification including amines, epoxides and hydroxyls. These reactive groups or binding sites follow from the various chemical treatments of plastic and glass described in Applicants' examples and set forth in Chart 8, also dated 12/3/02. Altogether, there are seven treatments listed in Chart 8, of which three treatments are used for plastic, two are used for glass, and two are used for both plastic and glass.

To reiterate, one of Applicants' disclosed chemical treatments is dodecadiamine (DDA) described in Examples 5 and 6 for treating plastic. Two other chemical treatments, plastic treated with polylysine (PPL) and amino-derivatized (6-aminohexane linked), are described in Examples 5 and 6, respectively. Another chemical treatment, epoxy glue or solution, is disclosed in Example 6 for treating glass and plastic. Likewise, ammonium acetate is disclosed in Example 7 as another treatment for both glass and plastic. For glass treatment,  $\gamma$ -aminopropyltriethoxysilane and coating solution are disclosed in Examples 1 and 3, respectively. Together, these seven disclosed chemical treatments (Chart 8) are carried out to treat the non-porous solid support resulting in the three different reactive groups or binding sites (Chart 7) used for attaching nucleic acids thereto.

[13] To reiterate matters regarding Applicants' "binding practice," several treatments are described for fixing or immobilizing nucleic acids to a non-porous solid

support. Applicants' disclosure in this regard is not believed any broader or any more generic than their original disclosure.

**C. Various Nucleic Acids**

[14] New claims 3198 and 3199 recite an array comprising *various* single-stranded [or double-stranded] nucleic acids directly or indirectly fixed or immobilized to a non-porous solid support. As characterized in the Office Action, the subject matter of former claim 2715 is "directed to a generic non-porous solid support with various single-stranded nucleic acids or sequences fixed or immobilized thereto."<sup>7</sup>

[15] The specification does not limit Applicants' claimed array invention to "different" analytes deposited in wells or depression. Indeed, the specification speaks in several instances to plural sequences, analytes and DNA. See, for example, page 10, lines 31-34 ("Chemically labeled probes according to the invention are then brought into contact with the **fixed single-stranded analytes** under hybridizing conditions"); page 20, lines 25-26 ("the adherence or fixing of **DNA** to a polystyrene surface is improved by treating the surface with an . . ."); page 21, lines 19-21 ("several biotinylated probes, B-adeno-2-DNA and lambda DNA were hybridized to the immobilized **DNA**"); page 21, lines 21-22 ("To one set of immobilized **DNA**, no probe was added"); page 22, lines 34-36 ("An improved capability for fixing or

---

<sup>7</sup> In the September 7, 2000 Office Action (pages 4-5), the Examiner wrote:

The closest array description, as filed, is given in the specification on page 16, lines 9-27. In this description the array also is limited to glass plates having depressions or wells with denatured analytes deposited therein, wherein single stranded analytes are fixed to the surfaces of the wells. Chemically labeled probes may then be hybridized to these analytes and subjected to detection of any probe-analyte hybrid. It is noted that the analytes are characterized as being "various" which supports the presence of "different" analytes deposited in each well or depression (emphasis added).

The above statement was repeated in the October 10, 2001 Office Action (page 3, last ¶)

immobilization of **DNA** to non-porous siliceous solid supports, such as glass and plastic, is also provided . . ."); page 23, lines 30-31 ("Single-stranded analyte **DNA** is now fixed to the wells."). See especially the original Abstract ("**Polynucleotide sequences** . . . are detected by a method involving fixing of the **sequences** on a solid support").

[16] As explained in the last point [15] above, there is no reason of record why the specification does not reasonably convey to a person skilled in the art that Applicants were in possession of the subject matter reciting "various single-stranded nucleic acids or sequences," as set forth in the claims.

[17] Former claim 2933<sup>8</sup> recites "[a]n array of various nucleic strands or sequences thereof, said array comprising a non-porous solid support having wells or depressions, and said various nucleic acid strands or sequences fixed or immobilized in hybridizable form thereto." As explained in several points above, including most notably [1], Applicants use the terms "fixation" and "immobilization" synonymously and interchangeably. As listed in [1] above, ample support is provided in Applicants' specification for both terms and their synonymous useage. As indicated earlier in this paper, the citation at hand, page 16, is an embodiment that is disclosed in Example 1. As such, the example is "illustrative of preferred embodiments of the method of the present invention." Moreover, the page 16 citation in Example specifically begins with the introductory phrase, "For example."

To address further the issue of "various nucleic acids," Applicants are also submitting the Declaration of Dr. Alexander A. Waldrop, III.<sup>9</sup> Dr. Waldrop is a scientist and chemist with substantial experience and background in nucleic acid

---

<sup>8</sup> New array claims 3222 and 3223 recite "wells or depressions."

<sup>9</sup> Copy attached as Exhibit F.

chemistry, including modifying and labeling nucleic acids for use in hybridization and detection assays. He is familiar with several nucleic acid detection formats and nucleic acid probe technology in general. As set forth in his Declaration (¶12, page 9), Dr. Waldrop considers himself to possess the skill, knowledge, training and experience of a person skilled in the art to which the present invention pertains. In ¶14, pages 9-10, Dr. Waldrop concludes that the '070 specification reasonably conveys that Applicants were in possession of their claimed array invention, citing as support for his conclusion several passages from the specification. These passages are quoted and described in ¶15, pages 10-12, in Dr. Waldrop's Declaration.

Dr. Waldrop also provides additional evidence in several other paragraphs in his Declaration as to why the '070 specification does not limit the practice of "various denatured analytes" to an array of depressions or wells. This evidence is presented in ¶s 16-23 in Dr. Waldrop's Declaration. In ¶17, Dr. Waldrop quotes from the '070 specification the definition of "analyte," which is explained in ¶s 18-21. Other portions in the '070 specification are quoted in ¶s 22 and 23 by Dr. Waldrop as support for his conclusion that the specification conveys that Applicants were in possession of their array invention represented by claims 3198 and 3199.

**D. Non-Porous Glass/Plastic**

[18] As indicated in the opening remarks of this paper, new claims 3246 and 3247 recite "[a] *non-porous* glass or plastic solid support." As explained in earlier points and as reiterated below, the subject matter of new claims 3246 and 3247 and its dependent claims is fully supported by Applicants' disclosure.

[19] The matter of the terms "fixed" and "immobilized" has been exhaustively explained in [1] above. As noted above, these terms are used synonymously and interchangeably in Applicants' disclosure. Similarly, there is no evidence of record in

this application that would explain the difference between "fixation" and "immobilization."

[20] In view of the presentation of new claims 3246 and 3247 (both now reciting *non-porous* glass or plastic solid support), Applicants have obviated this point in the Office Action.

[21] Again, this point has been handled by the above presentation of new claims 3246 and 3247 (both now reciting *non-porous* glass or plastic solid support).

[22] As explained in [1] above and elsewhere in this paper, Applicants disclose that the terms "fixed" and "immobilized" are synonymous terms without any distinction or difference in their meaning. Furthermore, the specification uses both terms in the context of a glass solid support. In addition to the citation at hand (page 15, lines 16-20), Applicants use the term "fixed" with respect to glass in other contexts. See, for example, page 16, lines 9-14 ("For example, glass plates provided with an array of wells or depressions would have samples of the various denatured analytes deposited therein, the single-stranded analytes being *fixed* to the surfaces of the wells"). On the other hand, in other portions of their specification, Applicants also use the term "immobilized" and its variations in the context of glass solid supports. See, for example, page 15, last line, continuing through page 16, lines 1-2 ("The resulting treated glass surface will now have available alkylamine thereon suitable for *immobilizing* any negatively charged polyelectrolytes applied thereto"); and page 18, lines 23-25 ("In these tests, the analyte, phage lambda DNA, was *immobilized* on an activated *glass* surface according to the following procedure"). Even more significant is Applicants' disclosure on page 22, lines 34-37 ("An improved capability for *fixing or immobilization* of DNA to the non-porous siliceous solid supports, such as *glass* and plastic, is also provided by treatment with a coating of an epoxy resin"). Thus,

Applicants do not in any way limit their disclosure or claimed invention to instances where denatured single-stranded DNA sequences are "fixed" to glass. Indeed, the original specification is clear that nucleic acids and polynucleotides can be *fixed or immobilized* to a non-porous glass solid support, as set forth in amended claim 3030. As also explained above, this citation (page 16, lines 16-20) is part of the examples in the specification, and it is "illustrative of preferred embodiments" (page 15, lines 6-7).

[23] Applicants' disclosure on page 16, lines 8-14, does not limit new claims 3246 and 3247 with respect to the nature of the non-porous glass solid support recited therein. Indeed, in other portions of their specification, Applicants disclose non-porous glass solid supports for fixing or immobilizing nucleic acids where the glass does not contain wells or depressions. See, for example, page 18, lines 23-26 ("In these tests, the analyte, phage lambda DNA, was immobilized on an activated *glass surface* according to the following procedure. After rinsing with buffer, *glass tubes* were coated with . . ."); and page 22, last four lines, continuing through page 23, line 5 ("An improved capability for fixing or immobilization of DNA to *non-porous siliceous solid supports*, such as *glass* and plastic, is also provided by treatment with a coating of an epoxy resin. For example, *treatment of glass or polystyrene surfaces* with commercially available epoxy glues, such as a solution of epoxy glue in ethanol (1 percent w/v) serves this purpose. These epoxy solutions are applied to the *surfaces or wells*, and the solvent . . .").

Additionally, and as explained above, this citation (page 16, lines 8-14) is part of the examples in the specification, and it is "illustrative of preferred embodiments" (page 15, lines 6-7). As explained in Applicants' earlier responses, this citation begins with the introductory phrase "For example." Furthermore, as a preferred embodiment for a solid support, "glass" is recited in original dependent claim 7 ("said **solid support** is selected from the group consisting of **glass**, . . ."). Also, "plastic or

glass wells" are disclosed on page 13, lines 34-37, as "[e]xamples of devices useful in the spectrophotometric analysis of the signal included **conventional apparatus employed in diagnostic laboratories**, i.e., plastic or **glass wells**, . . ." Thus, wells or depressions are not limiting on Applicants' claimed invention in the context of glass solid supports.

[24] As explained in earlier points, Applicants' use of glass tubes in Example 3 (page 18) is part of their examples and is "illustrative" of the preferred embodiments of their invention. Applicants' disclosure does not limit their claimed invention to glass solid supports containing wells or depressions or that are in the form of "glass tubes." The particular shape of the glass solid support is not essential to Applicants' invention. Instead, Applicants employed a number of different solid supports -- glass and plastic -- to illustrate a variety of embodiments, many of which are described in their examples and all of which are not intended to limit their claimed invention.

[25] To reiterate from earlier points above, the term "immobilized" has a synonymous meaning with its sister term "fixed." Four different treatments were used for glass and these are described in the specification (see Chart 8 dated 2/13/02) and this citation is merely describing one of Applicants' examples as "illustrative" of their preferred embodiments.

[26] This point is believed to have been obviated by the presentation of new claims 3246 and 3247, both reciting "[a] *non-porous* glass or plastic solid support comprising at least one nucleic acid fixed or immobilized thereto."

[27] As disclosed in the specification (and as set forth in Chart 8 dated 2/13/02), five treatments for plastic are described, one of which is **dodecylamine (DDA)** given in Example 6 (pages 21-22). Again, **DDA** and **DDA-coated polystyrene plates** are part



of their examples and are illustrative of Applicants' preferred embodiments. DDA treatment and DDA-coated polystyrene plates are not limiting, therefore, on the present claims except as already recited in various dependent claims.

[28] As explained in the specification, a microtiter well is an example of "conventional apparatus employed in diagnostic laboratories" (page 13, lines 35-37). Even Example 7 begins with the description "*Yet another example* of the method of the present invention, including fixing the polynucleotide analyte sequence directly to a non-porous solid support, such as a *conventional microtiter well*, may be performed according to the procedures outlined below." The next paragraph follows with "*[c]onventional microtiter well plates* can be pre-rinsed with 1M ammonium acetate (NH<sub>4</sub>OAc), which is one of two treatments held in common with glass and plastic (see Chart 8). Thus, microtiter wells are an embodiment for Applicants' invention and in no way should be taken as a limitation on new claims 3246 and 3247.

[29] The insertion of "non-porous" into new claims 3246 and 3247 is believed to have obviated this point.

[30] Applicants appreciate that the Examiner has considered Dr. Dollie Kirtikar's Declaration that was submitted with their October 31, 2003 Amendment Under 37 C.F.R. §1.115.

[31] As explained in Applicants' October 31, 2003 Amendment (page 92), Dr. Kirtikar's Declaration established (1) that the inventors investigated binding nucleic acids to a variety of differently shaped support materials, including flat microscope slides; (2) that the shape of the support material was irrelevant to the surface chemistry involved; and (3) that the inventors in fact constructed at least two arrays of different nucleic acids, one on a flat microscope slide and the other on a flat glass

fiber filter. Dr. Kirtikar's experiments and experimental data are consistent with Applicants' disclosure and invention in that her data and experiments cover a spectrum of solid supports, surfaces, shapes and treatments. Dr. Kirtikar's Declaration is testament to the careful investigation and research that was carried out in connection with Applicants' invention.

[32] As explained in the preceding point [31] above, Dr. Kirtikar's experiments and experimental data cover a spectrum of solid supports, surfaces, shapes and treatments. The experiments and data in her Declaration are consistent with Applicants' disclosure and invention that likewise illustrate a variety of solid supports, surfaces, shapes and treatments.

[33] Applicants reiterate their remarks in the last two preceding points [31] and [32]. Dr. Kirtikar's experiments and data are consistent with the variety of solid supports, surfaces, shapes and treatments carried out by Applicants and disclosed in their specification.

[34] The fact that preprinted slotted slides disclosed in Dr. Kirtikar's Declaration may not be specifically described in the specification should not detract from her experimental work which is consistent with the experimental work disclosed in Applicants' invention. Again, a number of solid supports, surfaces, shapes and treatments are described in Dr. Kirtikar's Declaration, and a variety of solid supports, surfaces, shapes and treatments are exemplified in Applicants' disclosure. Moreover, Dr. Kirtikar's use of slotted slides which are flat surface slides certainly shows that the shape of the solid support or surface is not *critical* to fixing or immobilizing nucleic acids.

[35] Applicants note with thanks the recognition in the Office Action rejection that the experimental material cited in Dr. Kirtikar's Declaration is consistent with the instant application. As far as the written description rejection, it is believed that all grounds and points have been thoroughly addressed and overcome, either by remarks and evidence, or by the presentation of an additional term in the case of claims 3246 and 3247 and their dependent claims.

In light of the above remarks and the submission of Dr. Waldrop's Declaration (Exhibit F), Applicants respectfully request reconsideration and withdrawal of the rejection for new matter.

**IV. Submission of Art-Related Documents**

Applicants filed their Third Supplemental Information Disclosure Statement on May 13, 2004. Applicants' attorney and his paralegal are presently reviewing the file wrapper for the purpose of bringing together a list of all art-related documents previously cited in office actions or submitted in various information disclosure statements. That list of previous documents made of record in this application is expected to be completed and submitted shortly.

Favorable action on this application is respectfully requested.

\* \* \* \* \*

**SUMMARY AND CONCLUSIONS**

A complete listing of the claims is provided above. Among the claims in the complete listing are new claims 3144-3286.

No fee or fees are believed due in connection with the filing of this Amendment which is being accompanied by a Notice of Appeal and authorization for the fee therefor. In the event that any other fee or fees are due, however, The Patent and Trademark Office is hereby authorized to charge the amount of any such fee(s) to Deposit Account No. 05-1135, or to credit any overpayment thereto.

If a telephone conversation would further the prosecution of the present application, Applicants' undersigned attorney request that he be contacted at the number provided below.

Respectfully submitted,

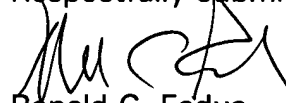

Ronald C. Fedus  
Registration No. 32,567  
Attorney for Applicants

**ENZO LIFE SCIENCES, INC.**  
c/o ENZO BIOCHEM, INC.  
527 Madison Avenue, 9<sup>th</sup> Floor  
New York, NY 10022-4304  
Telephone: (212) 583-0100  
Facsimile: (212) 583-0150

DNA Isolation and Sequencing  
Gel Electrophoresis: Proteins  
Gene Transcription: DNA Binding Proteins  
Gene Transcription: RNA Analysis  
PCR  
Cell Biology  
Human Chromosome Preparation  
Antibody Production  
Mammalian Cell Culture  
Plant Molecular Biology  
Nucleic Acid Hybridization

# NUCLEIC ACID HYBRIDIZATION

## ESSENTIAL TECHNIQUES

Edited by  
J. Ross

*McArdle Laboratory for Cancer Research,  
University of Wisconsin-Madison Medical School, USA*

JOHN WILEY & SONS  
Chichester • New York • Weinheim • Brisbane • Singapore • Toronto

Copyright © 1998 by John Wiley & Sons Ltd, Baffins Lane, Chichester, West Sussex PO19 1UD, England  
 National 01243 779777; International (+44) 1243 779777  
 e-mail (for orders and customer service enquiries): cs-books@wiley.co.uk  
 Visit our Home Page on <http://www.wiley.co.uk> or <http://www.wiley.com>

All rights reserved. No part of this publication may be reproduced, stored in a retrieval system, or transmitted, in any form or by any means, electronic, mechanical, photocopying, recording, scanning or otherwise, except under the terms of the Copyright, Designs and Patents Act 1988 or under the terms of a licence issued by the Copyright Licensing Agency, 90 Tottenham Court Road, London, UK W1P 9HE, without the permission in writing of the publisher.

Researchers using the procedures of this book do so at their own risk. The editors and John Wiley & Sons make no representations or warranties with respect to the material set forth in this book and have no liability in connection with the use of these materials.

*Other Wiley Editorial Offices*

John Wiley & Sons, Inc., 605 Third Avenue,  
 New York, NY 10158-0012, USA  
 WILEY-VCH Verlag GmbH, Pappelallee 3,  
 D-69469 Weinheim, Germany  
 Jacaranda Wiley Ltd, 33 Park Road, Milton,  
 Queensland 4064, Australia  
 John Wiley & Sons (Asia) Pte Ltd, 2 Clementi Loop #02-01,  
 Jin Xing Distripark, Singapore 129809  
 John Wiley & Sons (Canada) Ltd, 22 Worcester Road,  
 Rexdale, Ontario M9W 1L1, Canada

*Library of Congress Cataloging in Publication Data*

Nucleic acid hybridization/edited by J. Ross  
 p. cm. — (Essential techniques series)  
 Includes bibliographical references and index.  
 ISBN 0-471-97125-1 (pbk. : alk. paper)  
 I. Nucleic acid hybridization—Laboratory manuals. I. Ross, J.  
 (Jeff), 1943— II. Series.  
 QP620.N777 1998  
 572.8'4—dc21  
 97-19726  
 CIP

*British Library Cataloguing in Publication Data*

A catalogue record for this book is available from the British Library  
 ISBN 0 471 97125 1

Typeset in 10/12pt Times from the author's disks by Footnote Graphics, Warminster, UK  
 Printed and bound in UK by Biddles Ltd, Guildford, UK

This book is printed on acid-free paper responsibly manufactured from sustainable forestation, for which at least two trees are planted for each one used for paper production.

**CONTENTS**

Contributors	ix	<i>In vitro</i> transcription	12
Abbreviations	x	Reducing the size of the RNA probe to 200–250 nts	13
Preface	xii	3'-Oligonucleotide tailing	13
Safety	xiii	PCR	13
<b>I General Introduction. J. Ross</b>	<b>1</b>	Tagging DNA with enzymes	14
The rate of nucleic acid hybridization	1	For probe detection:	14
Reactant concentration and the background problem	1	Autoradiography and computer-aided detection instruments	14
Kinetics of hybridization	3	Chemiluminescent detection for HRP-tagged	14
The mechanism of nucleic acid hybridization	4		



## IV NUCLEIC ACID FILTER HYBRIDIZATION. B.M. Harvey

### Introduction

Filter hybridization involves immobilizing single-stranded target DNA or RNA on a membrane and then incubating the membrane with a probe for the nucleic acid of interest [1]. Filter hybridization is used primarily to detect gel-fractionated nucleic acids following membrane transfer. Transfers of gel-fractionated DNA or RNA are referred to as Southern or northern blots, respectively [2-4].

After gel electrophoresis and transfer, the nucleic acid is 'fixed' or immobilized by heating the membrane or exposing it to UV light. The nature of probe-membrane binding is incompletely understood but is believed to be hydrophobic. The hybridization process itself is divided into three steps: pre-hybridization, hybridization, and stringency washing. In pre-hybridization the blot is incubated with a solution designed to 'block' non-specific binding of the probe to the membrane. The same buffer is often used also for step two. No probe is present during step one. In step two the membrane is incubated with single-stranded probe in a hybridization buffer. The membrane-bound target cannot anneal with itself but will hybridize to the probe. Step three is a washing procedure designed to remove unhybridized probe and unstable (poorly matched) hybrids from the membrane. Adequate washing under the most stringent conditions possible lowers background.

Guidelines on how to choose a membrane, optimize target-to-membrane transfer, and fix the membrane are outlined below. No single set of conditions or criteria is optimal for all membranes, targets, and probes. The protocols are guidelines applicable for most experiments, but you should consult Chapter I for additional information when troubleshooting is required.

### Choosing the right membrane

The membrane of choice is determined by two factors: the sensitivity required and the detection method. Sensitivity depends on target abundance, probe specific activity, and hybridization and washing conditions. Experience is the best teacher for dealing with these variables. Nitrocellulose is adequate when the target is abundant and sensitivity is not an issue. Nylon is the membrane of choice for most experiments.

### Nitrocellulose

Nitrocellulose is available in two forms, unsupported and supported. The supported form is preferable, as it has higher tensile strength and is less fragile. Supported nitrocellulose is available from Amersham, Micron Separations, Inc., Schleicher and Schuell, Sartorius, and Stratagene. Nitrocellulose usually results in low background and is recommended when the target is abundant. However, its nucleic acid-binding capacity is low ( $80-125 \mu\text{g}/\text{cm}^2$ ), as compared with nylon ( $400-600$



# Impact of surface chemistry and blocking strategies on DNA microarrays

Scott Taylor<sup>1</sup>, Stephanie Smith<sup>1</sup>, Brad Windle<sup>2</sup> and Anthony Guiseppi-Elie<sup>1,3,\*</sup>

<sup>1</sup>Center for Bioelectronics, Biosensors and Biochips (C3B), <sup>2</sup>Department of Medicinal Chemistry and <sup>3</sup>Department of Chemical Engineering, Virginia Commonwealth University, PO Box 843038, 601 West Main Street, Richmond, VA 23284-3038, USA

Received March 24, 2003; Revised May 15, 2003; Accepted June 2, 2003

## ABSTRACT

The surfaces and immobilization chemistries of DNA microarrays are the foundation for high quality gene expression data. Four surface modification chemistries, poly-L-lysine (PLL), 3-glycidoxypropyltrimethoxysilane (GPS), DAB-AM-poly(propyl-aminine hexadecaamine) dendrimer (DAB) and 3-aminopropyltrimethoxysilane (APS), were evaluated using cDNA and oligonucleotide sub-arrays. Two un-silanized glass surfaces, RCA-cleaned and immersed in Tris-EDTA buffer were also studied. DNA on amine-modified surfaces was fixed by UV (90 mJ/cm<sup>2</sup>), while DNA on GPS-modified surfaces was immobilized by covalent coupling. Arrays were blocked with either succinic anhydride (SA), bovine serum albumin (BSA) or left unblocked prior to hybridization with labeled PCR product. Quality factors evaluated were surface affinity for cDNA versus oligonucleotides, spot and background intensity, spotting concentration and blocking chemistry. Contact angle measurements and atomic force microscopy were performed to characterize surface wettability and morphology. The GPS surface exhibited the lowest background intensity regardless of blocking method. Blocking the arrays did not affect raw spot intensity, but affected background intensity on amine surfaces, BSA blocking being the lowest. Oligonucleotides and cDNA on unblocked GPS-modified slides gave the best signal (spot-to-background intensity ratio). Under the conditions evaluated, the unblocked GPS surface along with amine covalent coupling was the most appropriate for both cDNA and oligonucleotide microarrays.

## INTRODUCTION

The DNA microarray enables researchers to survey the entire transcriptome of virtually any cell population. This capability produces unprecedented quantities of raw data and enables the investigation of gene expression, functional genomics and

genetic complexity with potentially many more applications (1-4). Although production capabilities and use of microarrays are becoming increasingly well established, significant differences exist with regard to fabrication techniques and end user protocols. Such differences make it difficult to compare results across platforms and present data management challenges for the integration of databases. Fabrication parameters that may vary include: surface chemistry of slides (5-9), type and length of printed DNA (2,9) and immobilization or fixing strategies for the spotted DNA. Various end user protocols include: pre-hybridization surface blocking (3), mRNA labeling protocols, hybridization protocols, post-hybridization wash stringency and data analysis techniques (4,10,11). An additional area of great concern is the implementation (placement and type) of appropriate controls aimed at quality assurance and quality control. The absence of approaches that are based on 'best practices' for design, fabrication, and end use of microarrays makes comparative data analysis between groups problematic. Although some work has been recently published that addresses several of these issues, (2-7,9-13) there is still little consensus about which design features and end user protocols are optimum for highest quality microarray data. In a recent attempt to develop microarray standards, the authors of the MIAME (minimum information about a microarray experiment) protocol have introduced guidelines for establishing standards concerning the information requirements for a more effective comparative analysis of microarray data between groups (10). The emphasis on these guidelines is however on documentation and not on engineering guidance. This paper aims at providing engineering guidance in the fabrication of cDNA and oligonucleotide microarrays.

The glass surfaces of DNA microarrays have been modified in various ways to immobilize DNA (oligonucleotides and/or cDNA) (5-9). Common surface modifications for printing and affixing DNA onto glass slides are: poly-L-lysine (PLL) (14), 3-aminopropyltrimethoxysilane (APS) (3,5,9), 3-glycidoxypropyltrimethoxysilane (GPS) (7,9) and aldehyde or carboxylic acid (5). DNA has also been directly printed onto unmodified glass (9). Amine-terminated cDNA and amine-terminated oligonucleotides may be covalently coupled to epoxide, isothiocyanate and aldehyde activated glass surfaces (7). Non-terminated DNA has also been spotted onto amine-functionalized surfaces such as PLL, APS and surfaces that

\*To whom correspondence should be addressed at Center for Bioelectronics, Biosensors and Biochips (C3B), Virginia Commonwealth University, PO Box 843038, 601 West Main Street, Richmond, VA 23284-3038, USA. Tel: +1 804 827 7016; Fax: +1 804 827 7029; Email: guiseppi@vcu.edu

were functionalized and derivatized with polyamidoamine dendrimer (PAMAM) (6).

One possible advantage of GPS, APS and PAMAM over PLL is that the former are covalently immobilized to the silicon bearing hydroxide functional groups on the surface of glass, while PLL is immobilized by adsorption, the result of acid-base interactions and hydrogen bonding with the amphoteric glass surface (15). Moreover, it has been reported that aminosilanes and PAMAM surfaces offer a more consistent surface than PLL, with lower background and higher overall fluorescent signal intensities (6). Given that there are  $\sim 5.0$  silanol groups/nm<sup>2</sup> on a fully hydroxylated silica surface that is supplemented by a few layers of surface bound water, and given that the APS molecule could pack to a limit of  $\sim 5$  molecules/nm<sup>2</sup> (perfect hydrocarbon chain packing, e.g. c-axis of polyethylene crystals packs at  $\sim 5.2$ – $5.4$ ), then it is likely that a well-packed APS layer would typically present in the range 3.5–4.0 amine groups/nm<sup>2</sup> (16,17), while PAMAM derivatized surfaces present  $\sim 66$  amines/nm<sup>2</sup> (18). In addition, PLL surfaces generally require an induction period of  $\sim 2$  weeks before they can produce consistent microarray results (3). PLL, APS and PAMAM all present amine functional groups suitable for interaction with DNA via hydrogen bonding and, potentially, via electrostatic interactions (9) under the appropriate pH conditions. DNA is commonly 'cross-linked' on these surfaces by exposure to UV light, however this process is poorly understood but is believed to involve the creation of radicals that induce inter-chain cross-linking. GPS, in contrast, allows amine-terminated DNA to be covalently immobilized to the surface (19) via an amine-initiated nucleophilic ring opening reaction that leads to covalent bond formation between the GPS and the amine-terminated DNA.

Blocking reactions are typically employed to prevent labeled reverse transcription product from adsorbing to the surface of the printed microarray during the hybridization reaction. Blocking methods provide the added advantage of washing away unbound DNA from the surface that would otherwise compete with the labeled species (3). Two of the most common blocking methods to address non-specific adsorption on amine-modified microarrays involve blocking with succinic anhydride (SA) (3,14) or bovine serum albumin (BSA) (3). Both are intended to block the unreacted functional groups of the printed microarray with chemistries that have low affinity for DNA.

In this paper, we report an evaluation of spotting concentration, surface chemistries and blocking strategies for their combined role in the performance of oligonucleotide and cDNA microarrays. Our goal was to establish optimum protocols for manufacturing, spotting, hybridization and scanning of microarrays. cDNA and oligonucleotide microarrays were therefore spotted on six different surfaces. These surfaces evaluated were: APS, GPS, DAB-AM-16-poly(propyleneimine hexadecamine) (DAB), and PLL. DAB is a generation 3 dendrimer that was linked to the glass surface via covalent coupling following surface modification with GPS. In addition, two unmodified blank slides: (i) RCA-cleaned, but not surface modified (RCA); and (ii) cleaned and immersed in Tris-EDTA buffer (TEB) were also evaluated. Microarrays were blocked with either SA (SA-blocked), BSA (BSA-blocked) or left unblocked. These surfaces represent a broad

range of available surface chemistries. The GPS presents the reactive glycidoxo functional group to which amine-terminated oligonucleotides and cDNA, derived from amine-terminated primers, could be covalently affixed. The APS, PLL and DAB surfaces present varying densities of amine functionalities for hydrogen-bonding interactions with DNA. The RCA-cleaned glass slides served as a reference surface while the TEB immersion deliberately introduced surface contamination to otherwise cleaned glass slide surfaces. The non-blocked surface served as the control for blocking. These surfaces and blocking strategies were evaluated by fabricating microarrays of cDNA and 30mer oligonucleotides prepared using the human GAPDH gene sequence. The oligonucleotides and cDNA were spotted at five different concentrations and hybridized to Alexafluor 555-labeled GAPDH PCR product. Wettability of the surfaces was determined by contact angle measurements with hexadecane and ultrapure water. Surface morphology was characterized by atomic force microscopy (AFM).

## MATERIALS AND METHODS

### Cleaning, preparation and surface modification of microarray slides

In a class 1000 clean room, 50 VWR brand glass microscope slides (VWR 48300-025) were solvent cleaned by immersion for 1 min in boiling acetone followed by 1 min in boiling isopropanol. The slides were then washed in ultrapure H<sub>2</sub>O (18 MOhm) for 1 min and dried with filtered nitrogen. Next, the slides were UV/ozonated for 15 min on one side using a Boekel UV Clean Model 135500 followed by ultrasonication in a Branson 1510 ultrasonicator in isopropanol for 5 min. The slides were then washed in diH<sub>2</sub>O and dried using filtered nitrogen. Finally, the slides were activated by immersion in a (5:1:1) solution of diH<sub>2</sub>O:hydrogen peroxide:ammonium hydroxide (RCA) at 60°C for 1 min, followed by diH<sub>2</sub>O wash, placed in glass slide carriers and dried in a convection oven for 30 min at 80°C. After this step, RCA-cleaned slides were stored for subsequent spotting.

The cleaned slides were then partitioned into six groups. One group of nine slides was modified by immersion in a solution of  $\gamma$ -APS 0.1% v/v in anhydrous toluene for 30 min at 40°C, washed three times in anhydrous toluene, placed in a glass staining dish and cured in a convection oven for 20 min at 110°C. The slides were then stored until needed for printing. Twenty-four slides were chemically modified by immersion in a solution of GPS 0.1% v/v in anhydrous toluene for 30 min at 40°C, washed three times in anhydrous toluene, placed in a glass staining dish and cured in a convection oven for 20 min at 110°C. Nine of these slides were stored for printing, and the remaining slides were subsequently modified by immersion in a solution of DAB 1.0% v/v in absolute ethanol overnight at room temperature. After the overnight incubation, the slides were washed three times in ethanol, placed in a glass staining dish and cured in a convection oven for 20 min at 110°C. The nine remaining slides were immersed in TEB (1.0 M Tris, 0.1 M EDTA) for 30 min at room temperature, washed in diH<sub>2</sub>O, dried in a convection oven and stored. Nine slides were modified with PLL. The slides were immersed in a solution of 70 ml phosphate-buffered saline, 70 ml of 0.1% PLL and

560 ml of diH<sub>2</sub>O, then incubated with gentle shaking for 1 h at room temperature. The slides were then washed five times in diH<sub>2</sub>O, dried with filtered nitrogen and placed in a 55°C vacuum oven for 10 min. All slides were stored in a plastic microscope box wrapped in aluminum foil then placed in a desiccator cabinet until needed for spotting. The PLL-modified slides were stored for 1 week prior to microarray spotting.

### Contact angle and AFM measurements

Contact angles of de-ionized water ( $\gamma_L = \gamma_L^p + \gamma_L^d = 53 + 20 = 73 \text{ mN m}^{-1}$ ) and anhydrous hexadecane ( $\gamma_L = \gamma_L^d = 26 \text{ mN m}^{-1}$ ) were measured at the cleaned or chemically modified microscope glass slides using an NRL Contact Angle Goniometer (Ramé-Hart Inc., Mountain Lakes, NJ). Octadecyltrichlorosilane (OTS) was used as a reference surface and was prepared following solvent cleaning by immersion in 0.1% v/v OTS in anhydrous toluene at 40°C for 30 min. The slides were then rinsed three times with toluene and dried at 110°C for 20 min. In a contact angle measurement, a droplet (~15  $\mu\text{l}$ ) of probe solvent was placed on the cleaned or modified glass slide from a fixed height, and the contact angle was directly measured through the focusing lens of the goniometer. AFM was performed using a Digital Instruments Dimension 3100 Atomic Force Microscope. Scan rates were set between 5 and 8 Hz depending on the image quality, and the scan size was changed from 1 to 10  $\mu\text{m}$  upon engagement of the cantilever. The instrument was operated in tapping mode to obtain the micrographs. The resulting height images were processed using Nanoscope III software. Images were flattened to remove scan lines, and the height scale was set to 75 nm. Feedback controls such as integral gain, proportional gain and amplitude set point were modulated in real time as the image was being generated. Integral and proportional gain were always set between 2 and 0.5.

### Preparation of GAPDH cDNA for arraying

The glyceraldehyde-3-phosphate dehydrogenase (GAPDH) gene fragment obtained from PCR was a source of cDNA for arraying onto the slides prepared in the previous step. Amine-modified PCR primers: forward: 5' amine-C6-ccaccatgg-caaattccatggcaccgtca and reverse: 5' amine-C6-ggttttctagacggcaggtcagggtccacc, were diluted to a working concentration of 0.001  $\mu\text{g}/\mu\text{l}$  and 10  $\mu\text{l}$  was then mixed with 0.5  $\mu\text{l}$  (5000 U/ $\mu\text{l}$ ) of New England Biolabs (NEB) *Taq* polymerase (M0267S), 0.1  $\mu\text{l}$  (200 mM) dNTPs (Invitrogen 10216-012, 014, 016, 018), 5  $\mu\text{l}$  of 10 $\times$  NEB PCR buffer, 0.5  $\mu\text{l}$  of GAPDH template and 34  $\mu\text{l}$  of diH<sub>2</sub>O per 50  $\mu\text{l}$  reaction for a total of 50 reactions. The reaction was initiated at 95°C for 30 s and cycled 29 times under the following conditions: melt at 95°C for 30 s, anneal at 50°C for 30 s and

extend at 72°C for 1 min using an MJ Research PTC-200 thermal cycler. After PCR, the reaction products were combined and distributed into three 1.7  $\mu\text{l}$  centrifuge tubes. To each tube was added 750  $\mu\text{l}$  of 100% ice-cold isopropanol and the tubes were centrifuged at 14 000 r.p.m. for 30 min in an Eppendorf Model 5804R centrifuge to pelletize the PCR product. The pellet was washed in 75% ethanol and re-pelleted by centrifugation at 14 000 r.p.m. for 30 min. After centrifugation the pellet was re-suspended in 20  $\mu\text{l}$  diH<sub>2</sub>O per tube and the contents of each tube were combined. The concentration of GAPDH in solution was quantified by UV spectroscopy with a Perkin Elmer Lambda 40 spectrometer. The GAPDH cDNA was diluted to the concentrations of 2.0, 1.0, 0.5, 0.2, 0.02 and 0.002  $\mu\text{g}/\mu\text{l}$ . An equal volume of 2 $\times$  spotting buffer (3 M Betaine, 6 $\times$  SSC) was added to each of the dilutions to make the 1 $\times$  spotting solution. The solutions were then distributed into separate 96 well V bottom microtiter plates using a Packard Biochip MultiProbeII Liquid Handling robot. The plates were stored at -20°C until needed for spotting.

### Preparation of oligonucleotides for arraying

Oligonucleotide primers were designed using the GAPDH sequence (accession no. NM\_002046) and synthesized by Integrated DNA Technologies. Table 1 lists the oligonucleotides, their 5' modification and their position in the GAPDH sequence. The forward, interior and random primers were diluted to the 2 $\times$  concentrations: 2.0, 1.0, 0.5, 0.2, 0.02 and 0.002  $\mu\text{g}/\mu\text{l}$  in diH<sub>2</sub>O and mixed with an equal volume of 2 $\times$  spotting buffer (3 M betaine, 6 $\times$  SSC). The forward, interior and random primers were arrayed on each type of chemically modified glass slide as well as onto the two groups of unmodified slides (RCA-cleaned and buffer immersed).

### Probe immobilization

Array fabrication was performed using a Cartesian Technologies PixSys 5500SQ Pin Array Robot and Liquid Dispensing System. Forward, interior and the random oligonucleotide sequences were spotted in three sub-arrays on slides that were modified with GPS, APS, DAB, PLL and the unmodified slides (RCA-cleaned and buffer immersed). PCR amplified GAPDH cDNA was also spotted on these slides in three additional but separate sub-arrays. The DNA arrayed on these surfaces was spotted in graded concentrations using the betaine spotting solution. The final DNA microarray layout is shown in Figure 1. After spotting, the APS, DAB, PLL, RCA and buffer immersed arrays were cross-linked with 90 mJ/cm<sup>2</sup> in an Ultra-Violet Products CL-1000 UV cross-linker and baked at 80°C for 1.5 h. The GPS arrays were incubated at 42°C in 50% humidity for 8 h, rinsed with 0.2% SDS solution for 2 min by vigorous shaking, washed three

Table 1. Oligonucleotide sequence information

Oligo name	Position	Modification	Sequence
Forward	228–258	Amine	ccaccatgg caaattccat ggcaccgtca
Reverse	802–811	Amine	ggttttcta gacggcaggt cagggtccacc
Interior	502–531	Amine	cagcctcaag atcatcagca atgctcctg
Unlabeled competitor	Complement of interior	None	caggaggcat tgctgatgat ctgaggctg
Randomer	None	Amine	acctggacct gaatccgccca tatagcctac

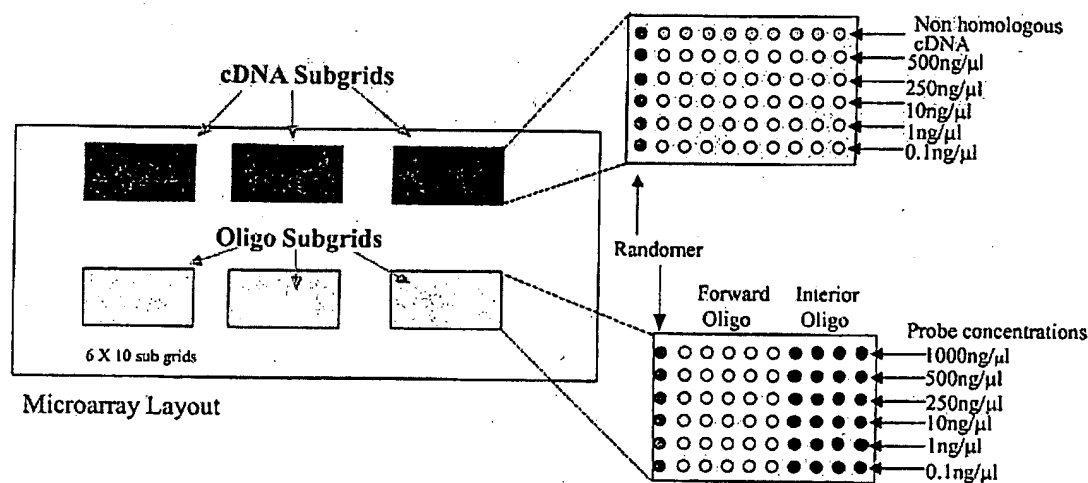

Figure 1. Microarray layout.

times in diH<sub>2</sub>O, incubated in diH<sub>2</sub>O at 50°C for 20 min then dried with filtered nitrogen. All arrays were then stored in foil-wrapped slide-boxes in a desiccator cabinet overnight prior to hybridization.

#### Labeling of GAPDH target

The forward and reverse oligonucleotide primers were used to amplify a 600 bp region of the GAPDH gene for fluorophore labeling. The previously described PCR protocol was used except that aminoallyl dUTP (Molecular Probes A-21664) was included in the reaction mixture at a ratio of 3:1 dUTP:TTP for a final concentration of 200 mM in each 80 μl reaction for a total of 60 reactions. The resulting PCR product was labeled using the ARES™ DNA labeling kit from Molecular Probes (A-21665) according to the supplied protocol.

#### Pre-hybridization blocking

Twelve slides were immersed in pre-hybridization buffer containing 5× SSC, 0.1% SDS and 1.0% BSA, incubated at 42°C for 45 min, washed 5× in diH<sub>2</sub>O then dried using filtered nitrogen. Another 12 slides were immersed in SA pre-hybridization solution containing 15 ml sodium borate and 6 g SA in 350 ml 1-methyl-2-pyrrolidinone. The solution containing the slides was incubated on an orbital shaker for 20 min, quenched in boiling diH<sub>2</sub>O, washed five times in 95% ethanol and dried using filtered nitrogen. Twelve slides were left unblocked. The remaining slides in the GPS and RCA groups were processed separately according to the same protocol.

#### Hybridization and imaging

Each group of slides was hybridized using a GenTac Hybridization Station (Genomic Solutions). 100 μl of hybridization buffer [4× SSC, 1× Denhardt's reagent, 5.0% SDS, 10% dextran sulfate, 40% formamide solution (50% v/v diH<sub>2</sub>O)] containing 40 ng labeled GAPDH cDNA and, for some experiments, 24 ng unlabeled competitor, was added to each microarray hybridization solution. The hybridization was allowed to proceed for 16 h at 42°C. After hybridization, the arrays were sequentially washed with medium stringency buffer (2× SSC, 0.1% SDS) (Genomic Solutions 16004001),

high stringency buffer (0.1× SSC, 0.05% SDS) (Genomic Solutions 16004501), post wash buffer (0.1× SSC) (Genomic Solutions 16003501) and diH<sub>2</sub>O. The arrays were then dried with filtered nitrogen. Each microarray was scanned at 5 μm resolution using a Perkin Elmer ScanArray 5000 microarray scanner using the 488 nm filter.

## RESULTS

### Surface chemistry and blocking strategy

Four chemically modified and two unmodified glass surfaces were studied for their characteristics relating to: (i) immobilization of cDNA and oligonucleotides, (ii) resulting slide background intensity after hybridization, (iii) signal intensity (spot intensity/slide background intensity) following hybridization and (iv) spotting uniformity. The surface chemistries evaluated were γ-APS, GPS, DAB (linked to the glass surface via GPS), PLL, a cleaned glass surface that had been immersed in TEB and a RCA-cleaned surface. These surfaces were selected because they are commonly used or otherwise cost effective/easy to implement in the microarray fabrication laboratory. While there are several alternative attachment chemistries (5,7), we limited this study to the most widely used and well-documented examples. Most cDNA microarray fabrication has been reported using PLL surfaces (2,3,14,15). However, Hegde *et al.* (3) and Liu *et al.* (20) have used APS surfaces for their cDNA microarray work and APS-modified glass surfaces are commercially available from Corning [CMT-GAPS slides (catalog no. 40004, Corning)] and Telechem [Super Amine slides (catalog no. SMM)] (web addresses for microarray substrates: Corning: [http://www.corning.com/LifeSciences/pdf/gaps\\_ii\\_coated\\_slides\\_10\\_01\\_ss\\_cmt\\_gaps\\_002.pdf](http://www.corning.com/LifeSciences/pdf/gaps_ii_coated_slides_10_01_ss_cmt_gaps_002.pdf) and Telechem: <http://arrayit.com/Products/Substrates/substrates.html>).

In an effort to identify a better microarray surface, one group has examined the amine presenting compound, PAMAM (6), and found it to have superior background and oligonucleotide capturing characteristics. We chose a closely related compound to that used by Benters *et al.* (6) for comparison with the common amine surfaces. As a means of

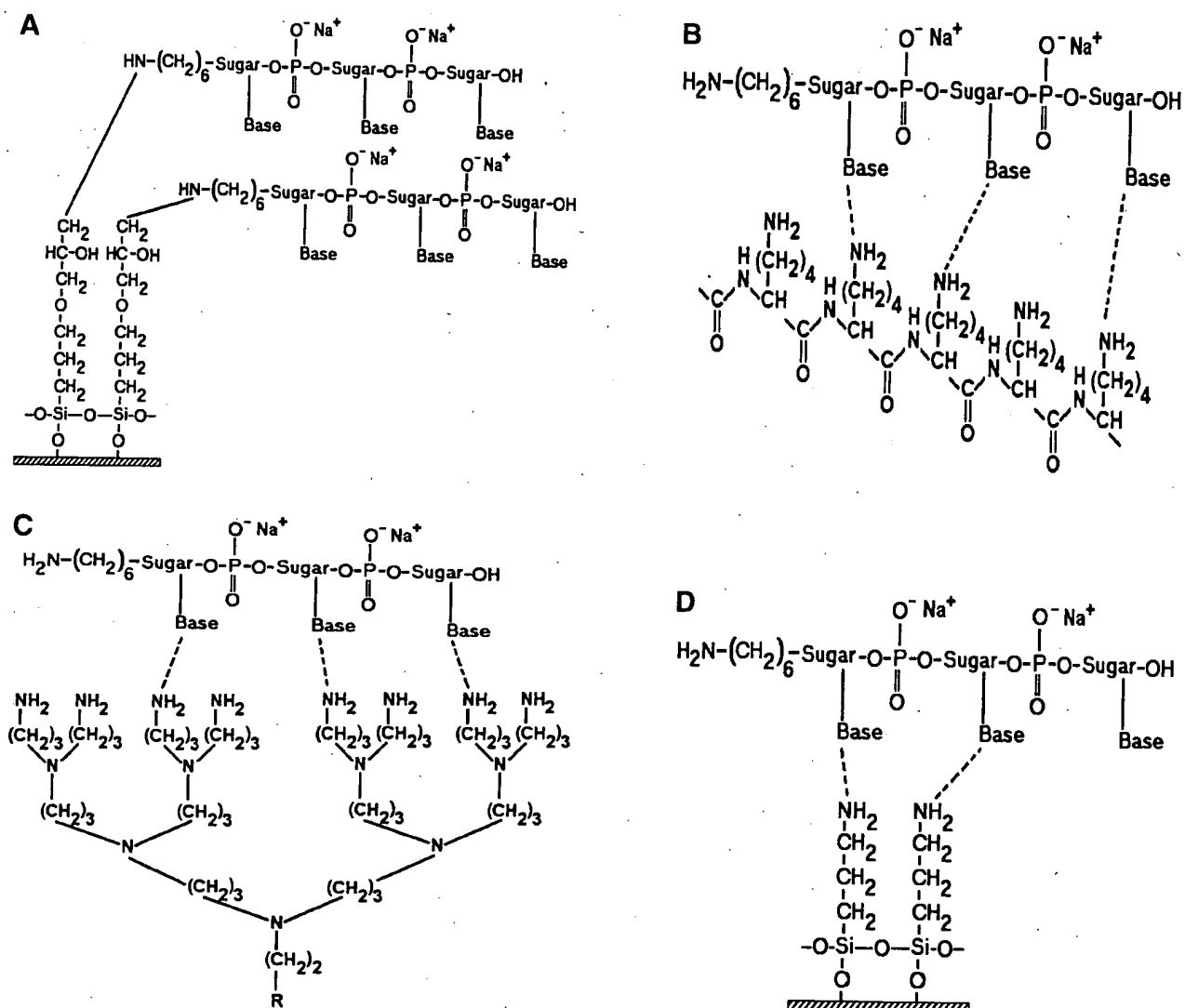

**Figure 2.** Schematic illustration of the various surface chemistries studied and the idealized interaction of DNA with functional groups on a glass surface. (A) GPS covalently bound to an amine-terminated oligonucleotide. (B) PLL hydrogen bonding with an oligonucleotide. (C) One-half of a DAB dendrimer hydrogen bonding with an oligonucleotide. (D) APS hydrogen bonding with an oligonucleotide.

covalent coupling, it has been reported that epoxy-silane (GPS) has been used for immobilizing amine-terminated oligonucleotides and cDNA (5,21). Figure 2 is a schematic illustration of the various surfaces studied.

The pre-hybridization blocking strategies studied were: no blocking, the adsorption of BSA and the reaction of SA. The ability of each of these three blocking strategies to reduce post-hybridization background intensity was investigated for each of the six surfaces. SA is commonly used as a blocking reagent in cDNA microarrays prepared on amine-functionalized surfaces (3,13). The anhydride readily reacts with the available amines forming the amide and thereby eliminating the amine from the surface with the intent of avoiding non-specific adsorption of DNA. Such an approach should be effective for both oligonucleotide and cDNA microarrays. A blocking solution containing BSA has been reported

by Hegde *et al.* (3) to result in lower background intensities when compared with SA. BSA is a neutral globular protein that readily adsorbs to surfaces and is commonly used in ELISAs.

There are two microarray platforms in wide usage: cDNA and oligonucleotide arrays. The oligonucleotide arrays vary in oligonucleotide length but are generally 25–70mers while printed cDNA typically ranges from 70 to 600 bp. Both types were evaluated in this study. The oligonucleotides selected were 30mers of the GAPDH gene and the cDNA was an ~600 bp PCR product amplified from GAPDH using amine-terminated primers. Both types of DNA were spotted over a broad range of concentration (0.001–0.5  $\mu\text{g}/\mu\text{l}$ ).

We measured spot quality as a function of spot and background intensities. All intensities were measured under the same conditions of laser power and PMT gain. Images

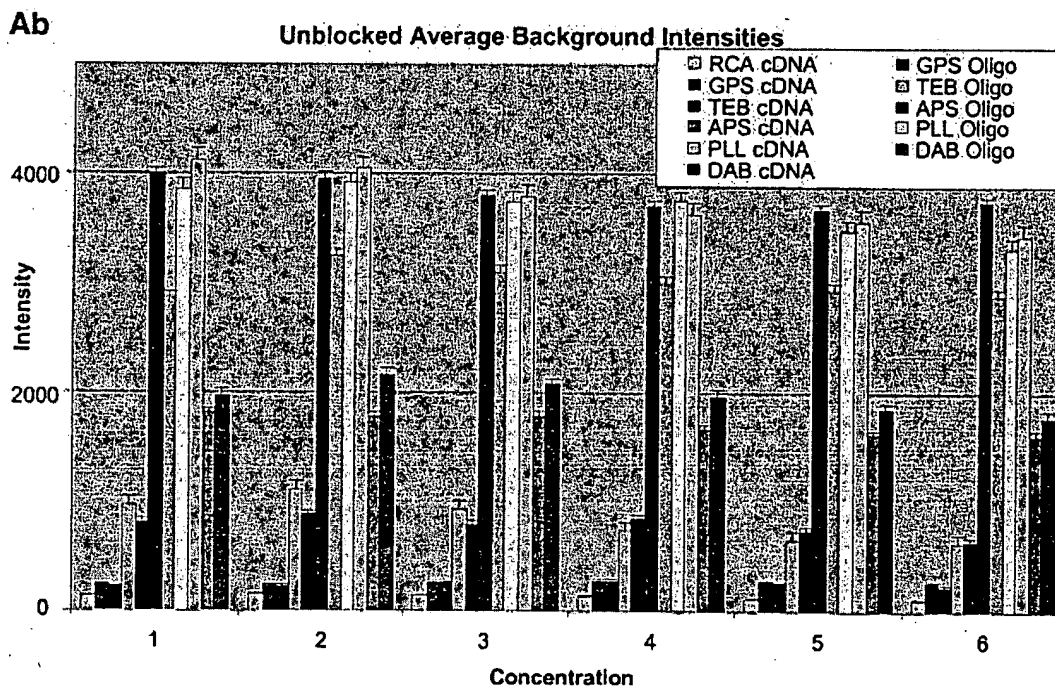
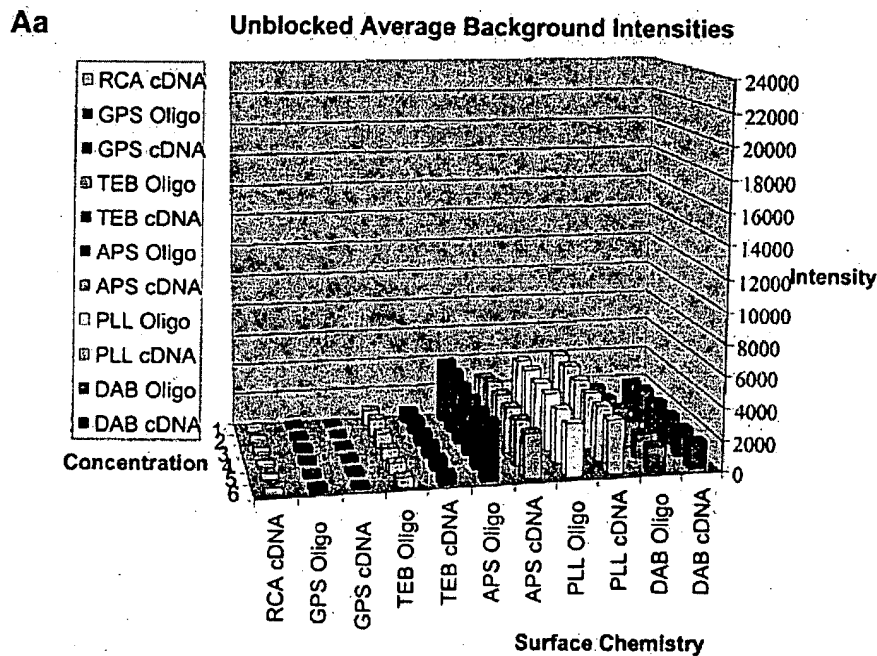

were subsequently scanned at the same resolution (5 microns). Our findings are presented according to the blocking strategy employed.

**Background intensities**

Figure 3A–C shows the average background intensities following hybridization to target for all the cDNA and oligonucleotide sectors of all six chemically modified surfaces. Background intensities were measured for each of the

six different spotting concentrations (0.001–0.5  $\mu\text{g}/\mu\text{l}$ ) employed and averaged over the many replicates for that concentration. We chose this approach to allow us to discern the influence of spotting concentration, and hence spot intensity, on the intensity of the background signal as perceived by the QuantArray software. All intensities were measured using the same QuantArray parameters and were plotted on the same scale to allow ready visual comparison of the data. Figure 3A shows the background intensity of

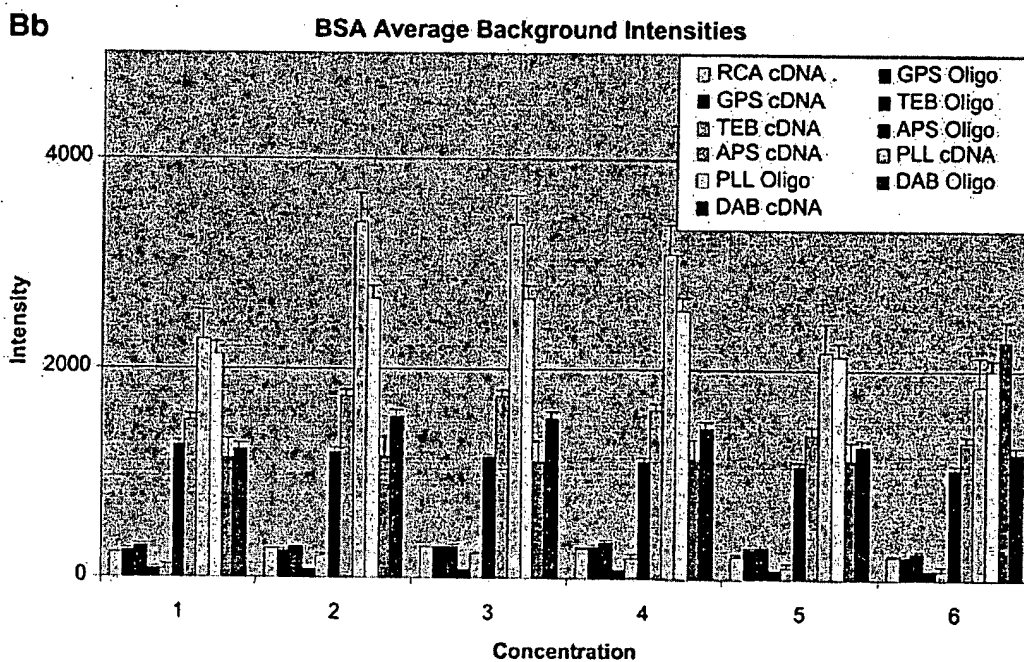
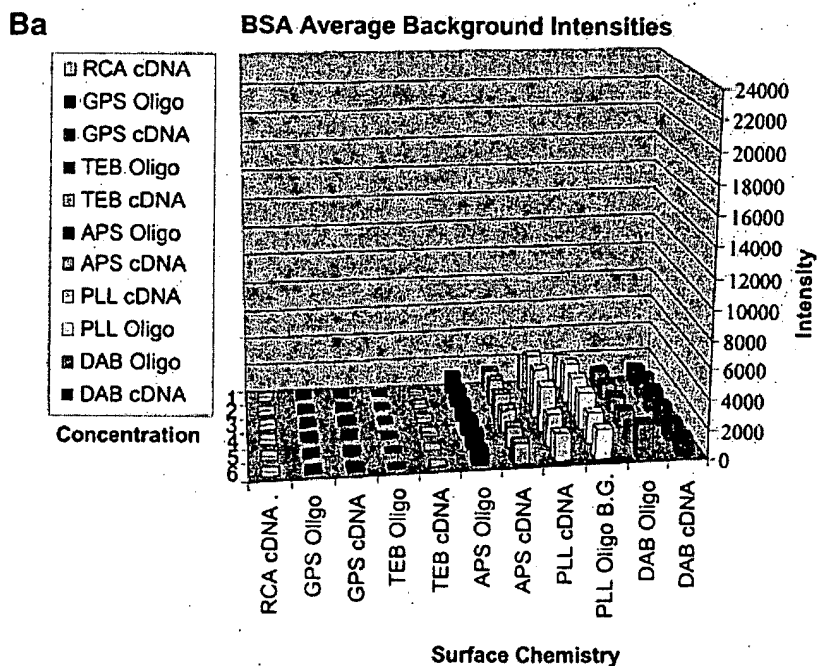

unblocked slides, while Figure 3B and C shows the background intensities of the BSA- and SA-blocked slides, respectively.

It can be seen in Figure 3A (unblocked) that the amine-bearing surfaces gave the highest background intensities (~4000 counts) when compared with the unmodified surfaces, RCA and TEB, and the epoxide-bearing surface. Figure 3B (BSA-blocked) shows very similar behavior to the unblocked slides. That is, the amine-bearing surfaces gave higher

background intensities when compared with the unmodified surfaces, RCA and TEB, and the epoxide-bearing surface. However, in this case the background intensities are between 1000 and 2000 counts, half as much as the unblocked slides. BSA therefore reduces the background intensity by ~50% compared with unblocked slides. It is noteworthy that this reduction in background intensity is most significant for the amine-bearing surfaces and does not significantly affect the background intensities of the unmodified surfaces, RCA and

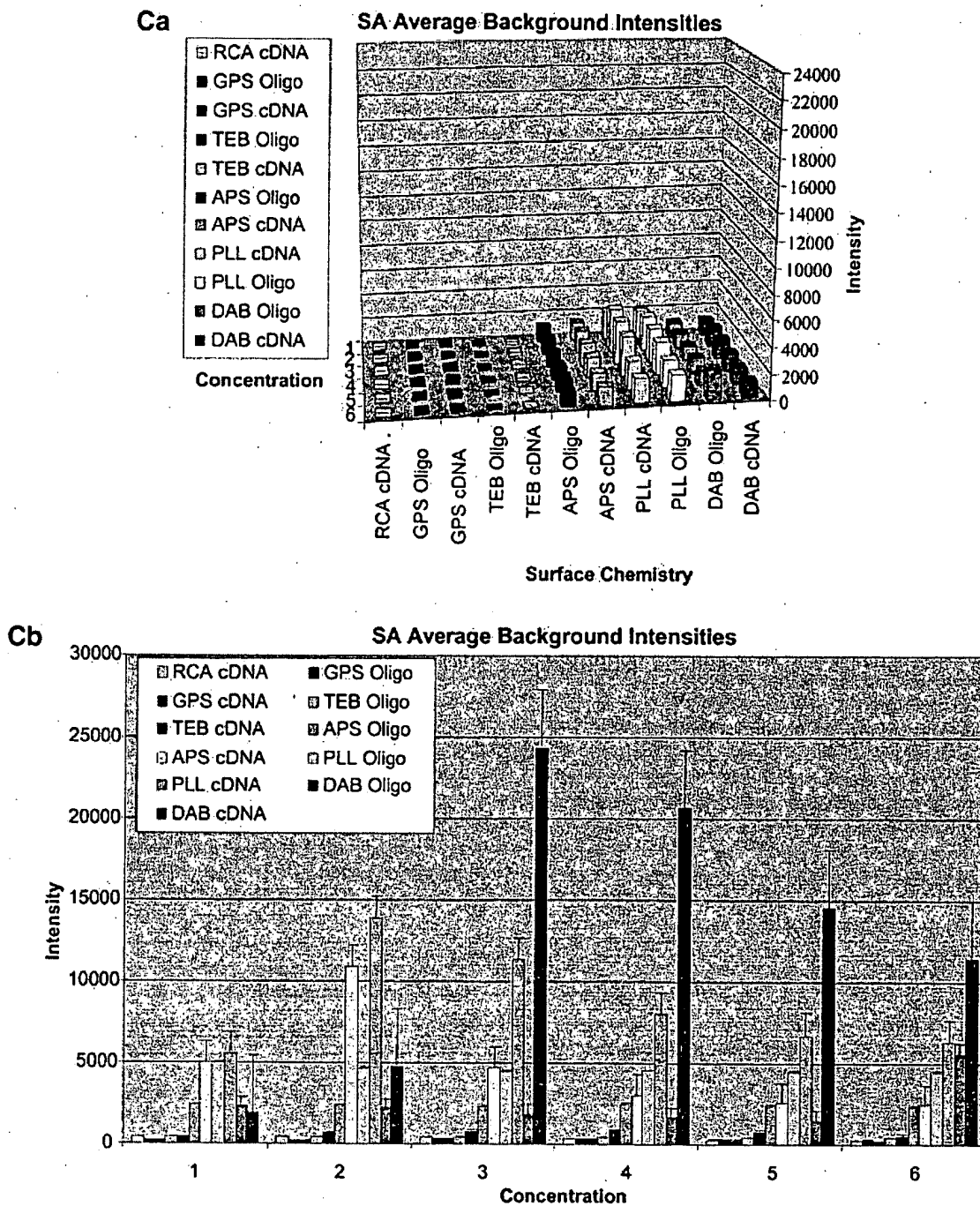

Figure 3. (Previous two pages and above) Average background intensities following hybridization of all cDNA and oligonucleotide sectors at different spotting concentrations (0.001–1.0 µg/µl) for all six surfaces studied. These are grouped by the blocking method employed; (A) unblocked, (B) BSA blocked and (C) SA blocked. (a) 3D bar charts of average background intensities as a function of spotting concentration and surface chemistry. (b) 2D bar charts showing the standard error.

TEB, or the epoxide-bearing surface. It can be seen in Figure 3C (SA-blocked) that the amine-bearing surfaces likewise gave higher background intensities compared with the unmodified surfaces, RCA and TEB, and the epoxide-bearing surface. However, in the case of SA blocking, these background values were considerably higher than those found for the amine-bearing surfaces on unblocked and BSA-

blocked slides. Here, background intensities ranged from 3000 to 24000 counts. There is also clear variation in the behavior of oligonucleotide and cDNA spots when blocked with SA. Oligonucleotide sectors were less prone to high background intensity counts while cDNA sectors gave high counts. Close observation of the scanned images revealed sizable comet tails on the cDNA spots. These observations



have been previously reported in microarray experiments using SA blocking (19,20, Oregon State Microarray Laboratory: <http://www.cgrb.orst.edu/CSL/custom.pdf>). SA appears to have a deleterious effect on UV-cross-linked cDNA spots, inducing comet tail formation, compromising the integrity of DNA spots.

### Spot intensities

Oligonucleotide and cDNA sectors were spotted at concentrations of 0.001, 0.01, 0.1, 0.25, 0.5 and 1.0  $\mu\text{g}/\mu\text{l}$ . Figure 4A and B shows the resulting raw spot intensities obtained over these six concentrations and under the three blocking conditions studied. For cDNA sectors the plots display a fairly sharp rise to plateau between 0.25 and 1.0  $\mu\text{g}/\mu\text{l}$  resulting in higher spot intensity values than oligonucleotide sectors. The oligonucleotide plots did not exhibit a plateau, rather they displayed a constant gradual rise and a smaller and more even slope. Although both types of DNA were spotted at the same concentration, the raw spot intensities of oligonucleotide sectors were generally lower than those of cDNA sectors (Fig. 4B versus A) over all surfaces studied. cDNA sectors displayed an ~2–8-fold higher raw intensity than oligonucleotide sectors for any given concentration.

The difference between cDNA and oligonucleotide spot intensities was especially apparent among the amine surfaces where spot intensities differed 8-fold. Oligonucleotides and cDNA exhibited close clustering at each concentration regardless of the surface modification employed, except for the buffer-treated surface. However, oligonucleotide intensity on the GPS surface was slightly higher than that found on other surfaces when blocked with BSA or in the unblocked condition. cDNA intensity from the GPS surface was tightly clustered with the other surfaces. Thus, the difference in intensity for oligonucleotide and cDNA sectors was ~2-fold between the concentrations 0.001 and 0.1  $\mu\text{g}/\mu\text{l}$ . This indicates that GPS is more effective for immobilizing oligonucleotides than the other surfaces. Measurable spot intensities for oligonucleotide sectors were not detected on RCA or TEB surfaces because the oligonucleotides, we believe, were washed away during blocking and/or hybridization.

### Signal intensities

Here we define signal intensity to be the spot intensity divided by the background intensity. Signal intensities were measured using the QuantArray software and are presented as log intensity versus log concentration plots and as bar charts with standard deviations in Figure 5A–C for cDNA and Figure 6A–C for oligonucleotide. Included on these plots is the expected theoretical dynamic range, where for 10-fold dilutions the slope =  $\log(10)$ . The figures show that GPS surfaces yielded the highest signal intensity for both oligonucleotide and cDNA sectors. RCA-cleaned and unmodified surfaces showed the second highest signal intensity for cDNA; however, there was no apparent signal from oligonucleotide sectors on RCA slides. The DAB-modified surface performed third best with oligonucleotides and cDNA, except for the SA-blocked cDNA sectors. In cDNA sectors from SA-blocked slides prominent 'comet tails' were observed originating from the cDNA spots. This feature contributed greatly to the background intensity and accordingly negatively impacted on signal intensity.

Generally, there was low variation in magnitude of raw spot intensity from cDNA sectors across all surfaces. Exceptions included the buffer treated slides, which had poor spot integrity (circularity and uniformity), and the RCA-cleaned surface under the unblocked and BSA-blocked conditions. In all cases the raw spot intensity on GPS surfaces was comparable, if not higher in magnitude, with the spots from the other surfaces (Fig. 4). However, since the background signal from the GPS surfaces was much lower than any of the other surfaces except RCA, the signal from the GPS surfaces was almost always greater between the spotting concentrations of 0.25 and 0.01  $\mu\text{g}/\mu\text{l}$ .

Note that in Figure 5A (unblocked cDNA sectors) the dynamic range line is matched only by the GPS-modified surface between 0.001 and 0.01  $\mu\text{g}/\mu\text{l}$ . Spots on the RCA-cleaned surface between the concentrations 0.1 and 0.5  $\mu\text{g}/\mu\text{l}$  also match the DR curve. No other surfaces show significant concurrence with the DR curve for this test condition. In Figure 5B (BSA-blocked cDNA sectors) it was observed that the RCA-cleaned surface matched the DR line between the concentrations 0.01 and 0.25  $\mu\text{g}/\mu\text{l}$  while GPS matched the DR line between 0.001 and 0.01  $\mu\text{g}/\mu\text{l}$ . The other surfaces (APS, PLL, TEB and DAB) conform better to the DR line between the concentrations 0.01 and 0.1  $\mu\text{g}/\mu\text{l}$  but still do not follow the expected slope exactly. In Figure 5C (SA-blocked cDNA sectors) it can be seen that the RCA-cleaned surface matched the DR line between the concentrations 0.001 and 0.10  $\mu\text{g}/\mu\text{l}$ . The amine-bearing surfaces APS, PLL and DAB appear to match the DR line in the region 0.10–1.00  $\mu\text{g}/\mu\text{l}$ . None of the remaining surfaces yields spots that conform well to the DR slope.

Figure 6A–C shows that none of the experimental oligonucleotide concentration curves conforms to the slope of the expected DR line. There was little change in signal intensity as a function of concentration of the spotted oligonucleotides.

### Spot quality

Spot quality is a global assessment that is comprised of parameters represented by spot footprint, circularity, intra-spot uniformity, inter-spot uniformity, signal-to-noise ratio and the coefficient of variation ( $\text{CV} = \text{standard deviation}/\text{mean}$ ) representing replicate uniformity. In general, circularity is governed by the setup conditions in QuantArray and is generally always close to unity. We focus here on spot footprint (diameter or area) and the CV of the signal intensities as a function of surface and type of DNA: the former because of its relation to contact angle and surface topology and the latter because of its relationship to replicate uniformity. Figure 7A (a, b and c) and B (a, b and c) are plots of the CV for signal intensities obtained over the various surfaces studied and under the three separate blocking conditions. The CV was calculated from the 360 (10 per sector  $\times$  3 per microarray  $\times$  12 microarrays) replicate spots representing each cDNA concentration and from the 324 (9 per sector  $\times$  3 per microarray  $\times$  12 microarrays) replicate spots representing each oligonucleotide concentration.

The CV was greater and more variable for cDNA sectors than for oligonucleotide sectors for all surfaces and across all blocking strategies. With few exceptions the CV for oligonucleotides was  $<0.4$  for all surfaces and blocking

**Aa Unblocked: cDNA Spot Raw Signal Intensity Signal**

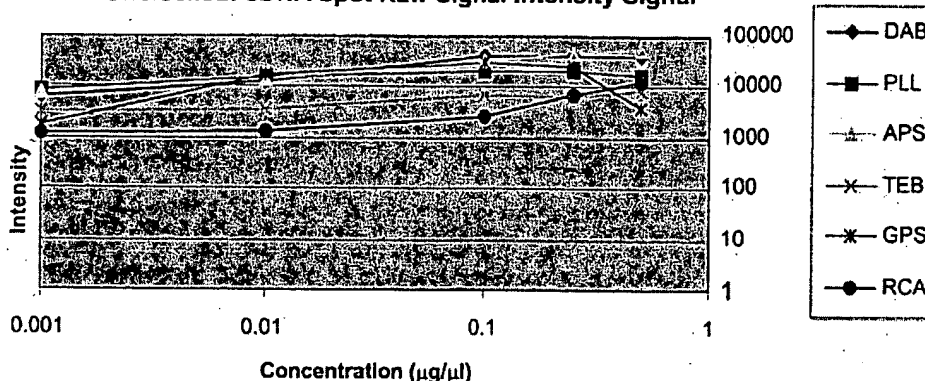

**Ab BSA Blocking: cDNA Spot Raw Signal Intensity Signal**

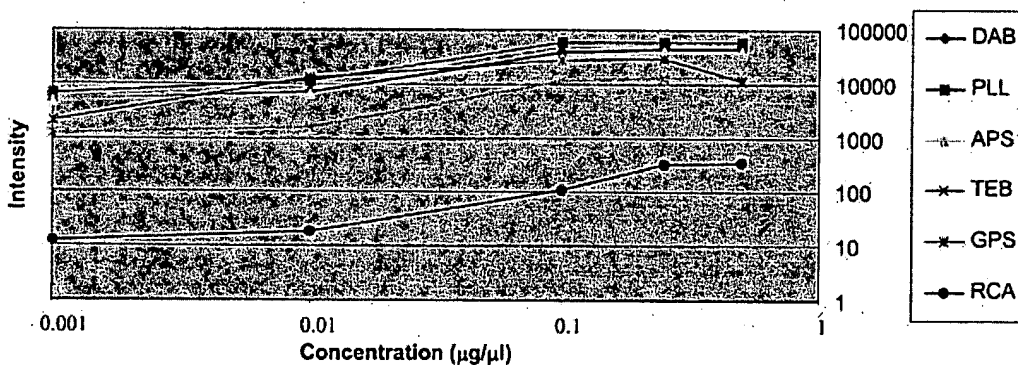

**Ac SA Blocking: cDNA Raw Spot Signal Intensity Signal**

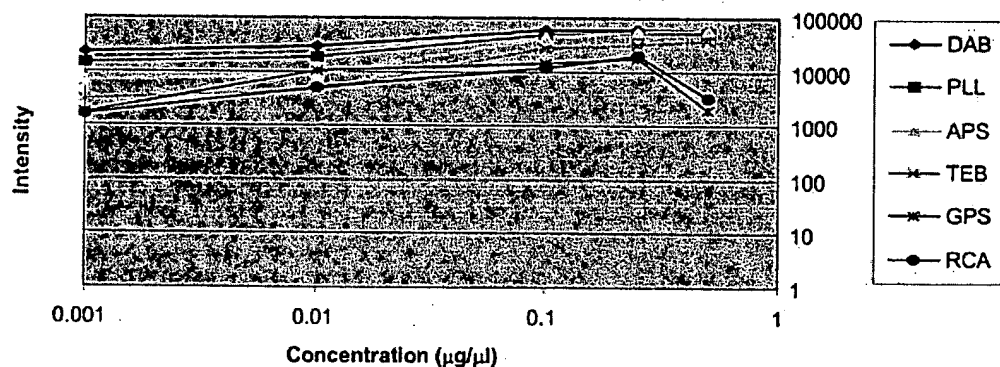

methods. This means that any given individual spot intensity reading would only be ~40% of the value of the mean. The modified and RCA surfaces performed similarly in terms of spot quality, while the buffer surface performed poorly. In the latter case the cDNA spots pooled together and formed larger irregular spots on the surface. The oligonucleotide spots completely washed off during blocking. RCA showed good spot quality for cDNA sectors but, like the TEB slides, the oligonucleotide sectors washed off.

**Contact angle measurements and AFM**

Contact-angle measurements were taken for each surface used in this experiment. Figure 8 shows the bar chart of these measurements taken with water (light gray) and hexadecane (dark gray). The bar chart most notably shows that the RCA-cleaned surface, with a water contact angle of ~48°, is comparable in hydrophobicity with the functionalized surfaces, while the TEB surface, because of its deliberate

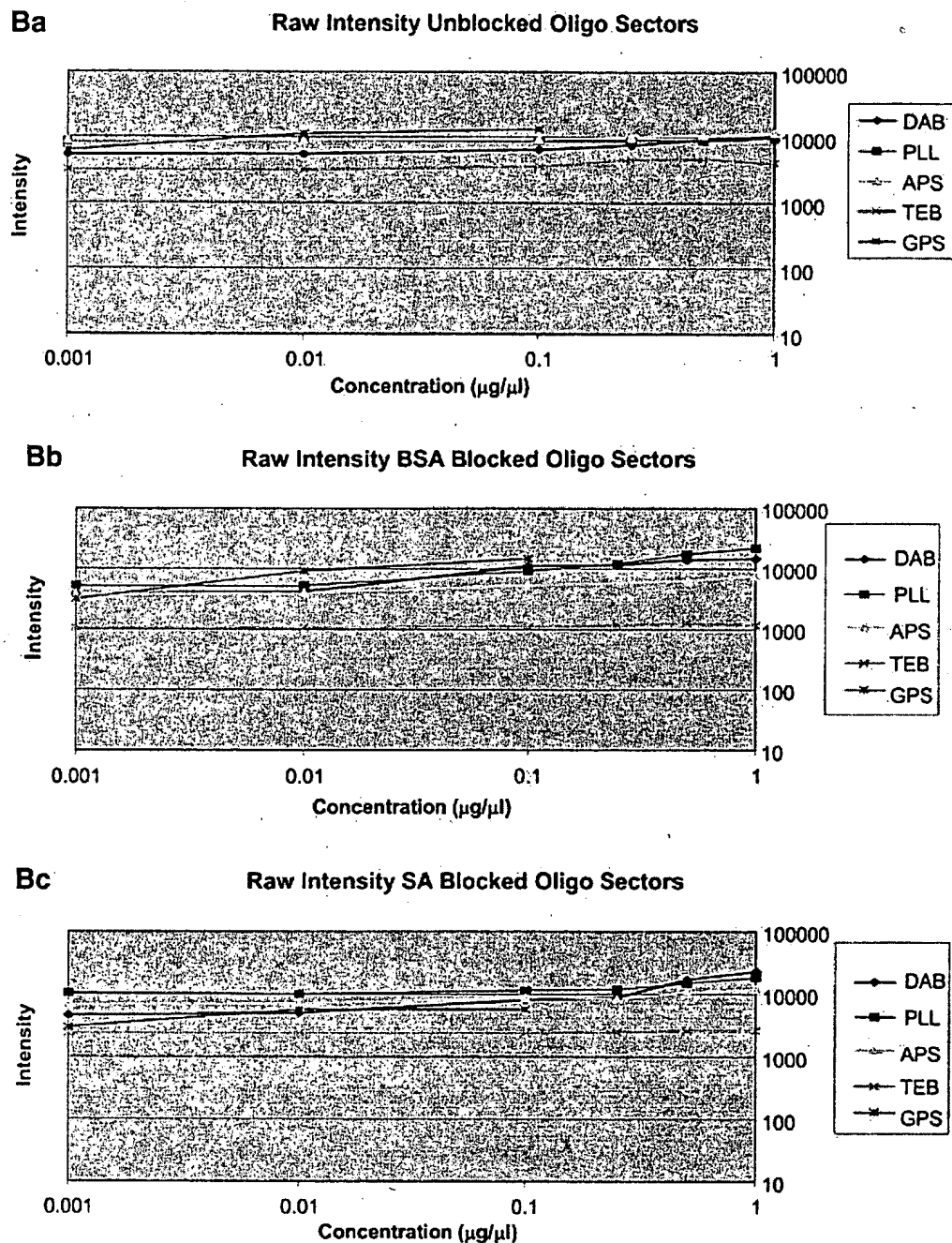
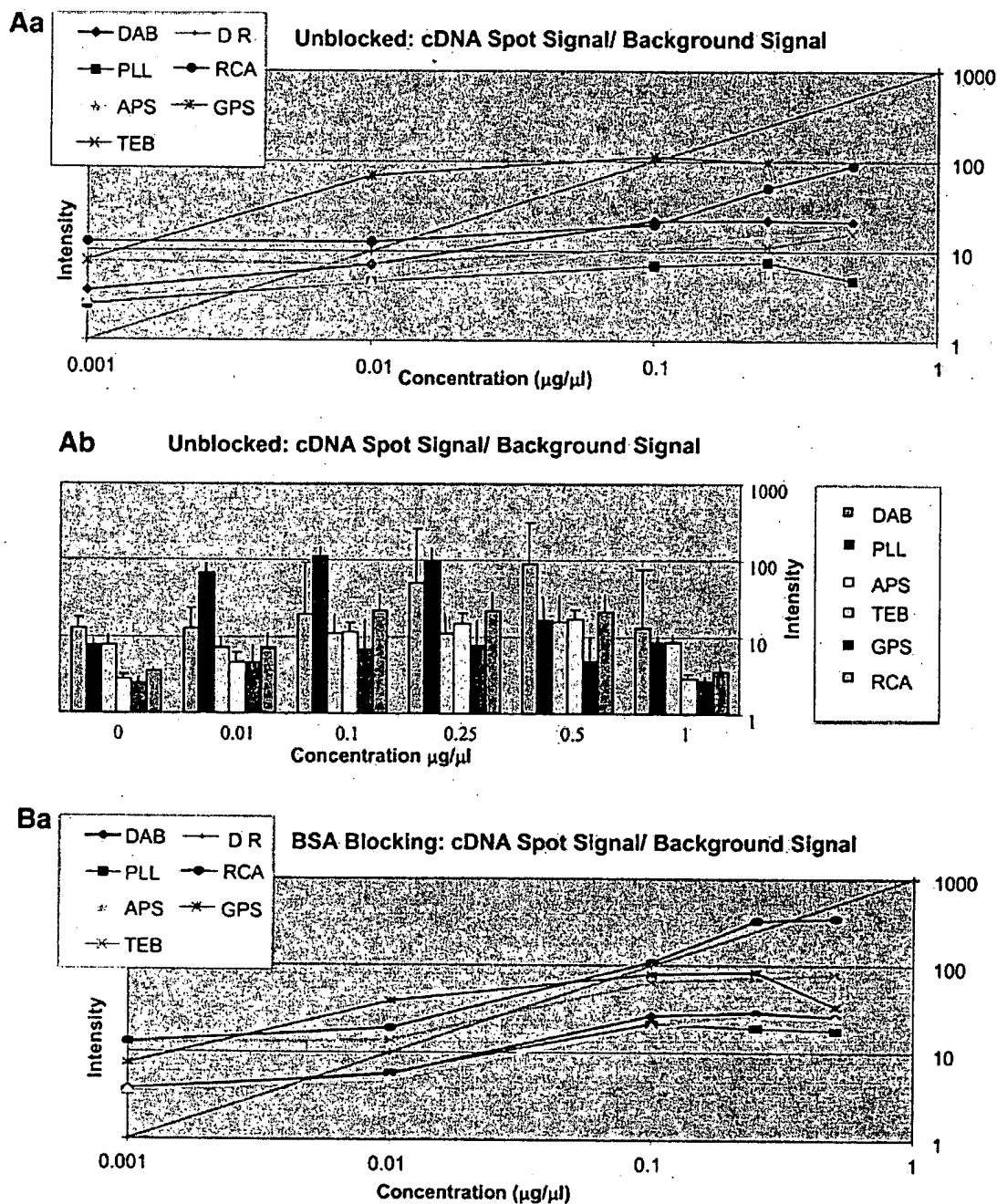

**Figure 4.** (Previous page and above) (A) Plots of logarithm of raw spot intensity data of cDNA sectors as a function of concentration over the range 0.001–0.5  $\mu\text{g}/\mu\text{l}$ . (a) Unblocked, (b) BSA blocked, (c) SA blocked. (B) Plots of logarithm of raw spot intensity data of oligonucleotide DNA sectors as a function of concentration over the range 0.001–1.0  $\mu\text{g}/\mu\text{l}$ . (a) Unblocked, (b) BSA blocked, (c) SA blocked.

salt contamination with TEB, was relatively hydrophilic. Furthermore, the water contact angle at the silane-modified surfaces [GPS (55°) and APS (74°)] are the most hydrophobic followed by PAMAM (40°) and PLL (34°).

Atomic force micrographs were taken at a 2.0  $\mu\text{m}$  scan size and presented on the 20 nm data scale of each of the surfaces studied and are presented in Figure 9. Uncleaned Gold Seal

glass surfaces displayed surface features on the order of 20 nm. Cleaning with the procedures used in this work (solvent and RCA) increases these features to ~40 nm. These features continue to be visible following surface modification with organo silanes, suggesting that the organo-silane layers are not very thick. These features are not evident on polished Schott D263 borosilicate glass that was evaluated for comparison.



**DISCUSSION**

**Surface chemistry**

Surface chemistry does not appear to be a critical factor influencing spot intensity data of cDNA microarrays. Recalling that all cDNA were amine terminated and therefore had the potential for direct chemical coupling to epoxy-modified surfaces, the cDNA sectors displayed similar spot intensities on epoxy-modified slides as were observed on the amine-modified slides, despite the difference in

immobilization protocol (covalent versus non-covalent coupling and UV cross-linking versus no UV cross-linking) and variable density of surface amine functionalities. With respect to the cDNA sectors, the main difference in performance among the various surfaces was found in the magnitude of the slide background intensities. Spot intensities were all quite similar in magnitude at each spotting concentration across all the different surface chemistries.

Surface chemistry appears to be more important for oligonucleotide microarrays. Oligonucleotides were not

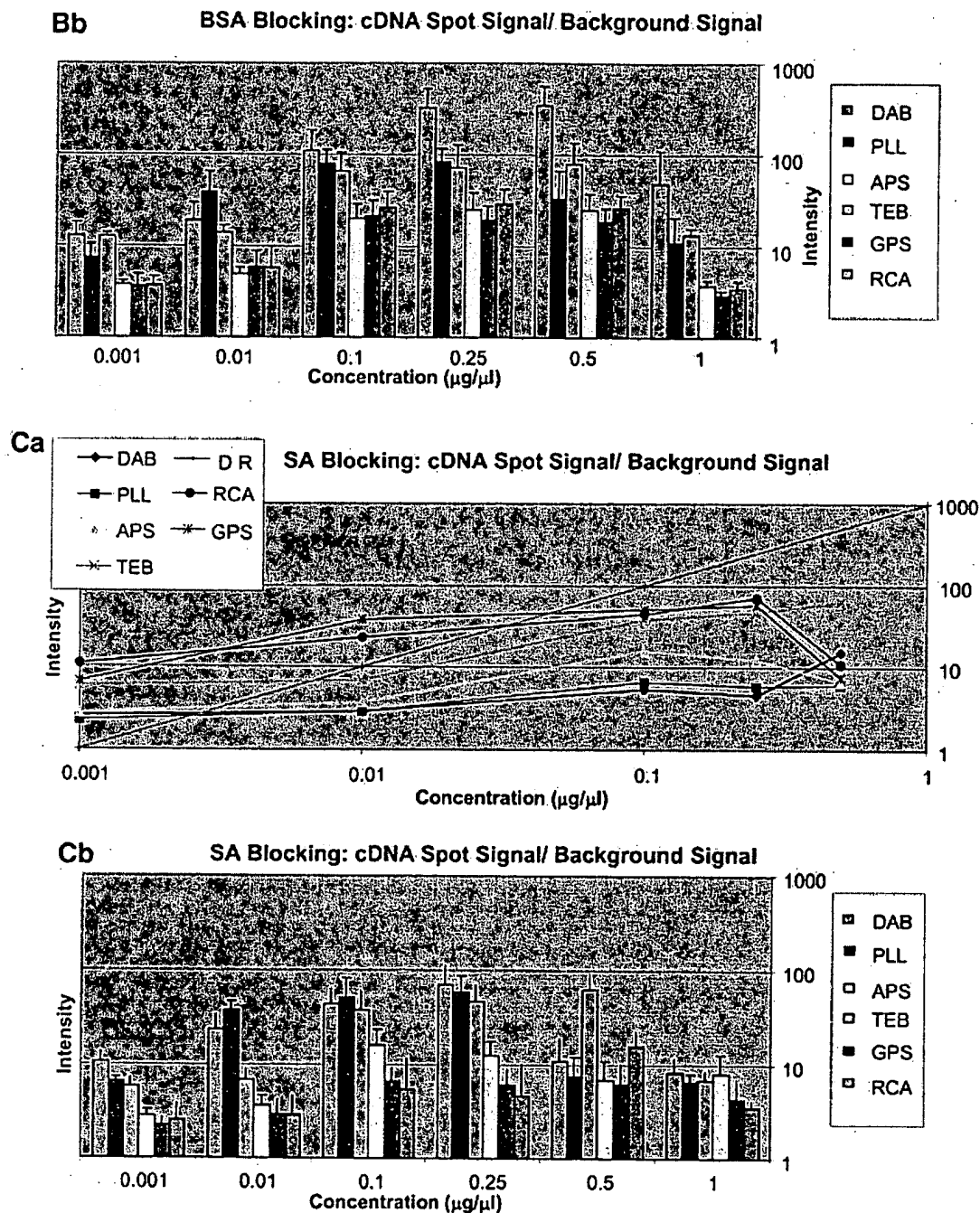
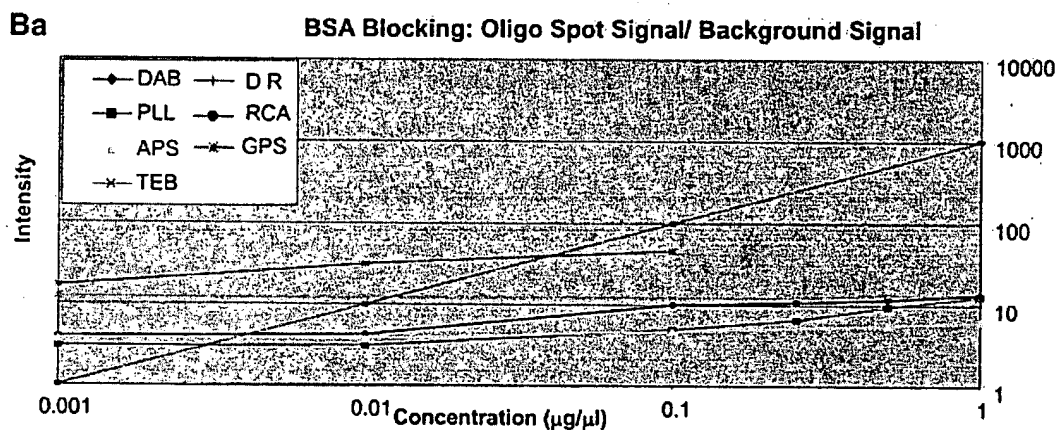
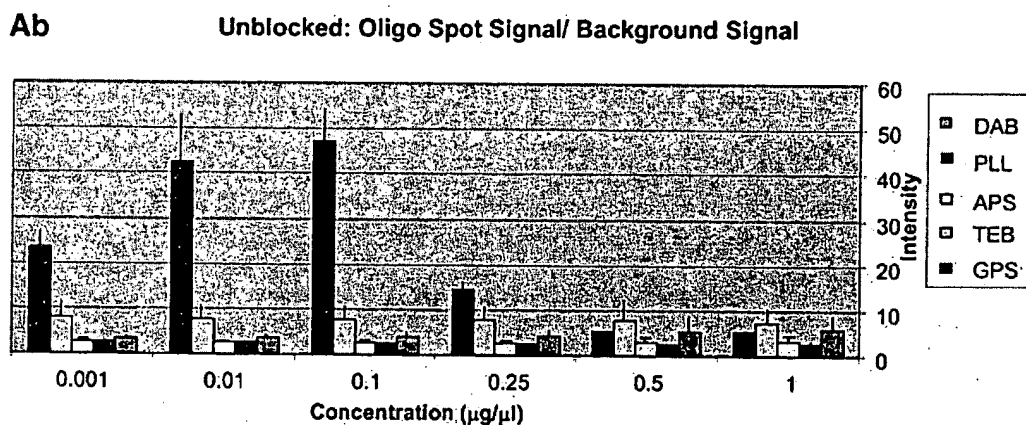
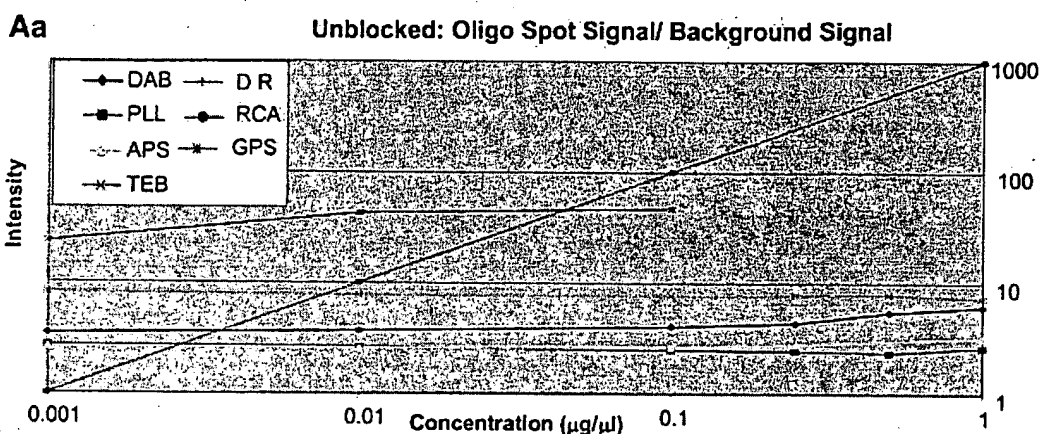

Figure 5. (Previous page and above) Plots of the signal intensity (spot/background) as a function of cDNA concentration at the various microarray surfaces employing: (A) unblocked, (B) BSA blocked, (C) SA blocked [(a) xy graph, (b) bar chart with standard deviation].

effectively immobilized on unfunctionalized surfaces such as TEB-washed and RCA-cleaned surfaces and resulted in very low spot intensities for both surfaces. Oligonucleotides were likewise not as effectively immobilized on amine surfaces (APS, PLL or DAB) when compared with cDNA on these surfaces and oligonucleotides on the epoxy-modified surface.

Unmodified but cleaned (RCA) glass slides outperformed all other surface chemistries except GPS with respect to its background intensity. As a consequence, the signal

(spot/background) from RCA and GPS slides was the highest. Since spots on the RCA-cleaned surface showed good circularity and uniformity (data not shown), had low CV across the several spotting concentrations (Fig. 4Aa-c), had overall low CV scores per concentration and were uniform across their diameter and yielded high signal, we conclude that RCA-cleaned glass slides presented the optimal surface for printing cDNA microarrays. This assertion reflects spot quality parameters but is likewise supported by production



cost considerations. Because of the low background intensity and the low variability across the several concentrations, the epoxy-modified surfaces presented the most suitable surfaces for printing of oligonucleotide microarrays.

**Background intensities**

The background intensity was determined for each spot and was defined within QuantArray as that region outside, but concentric with, the designated circular spot. In this way,

background intensity values capture the contributions of gross spot irregularities, spot smearing (comet-tails), the non-specific adsorption of labeled target in the specific region of the spot and any attenuation of the autofluorescence of the glass in that region of the substrate. Amine-modified surfaces yielded greater background fluorescence than epoxy-modified or non-functionalized surfaces. Furthermore, epoxy-modified surfaces had slide background intensities that were unaffected by either SA or BSA blocking. SA blocking negatively

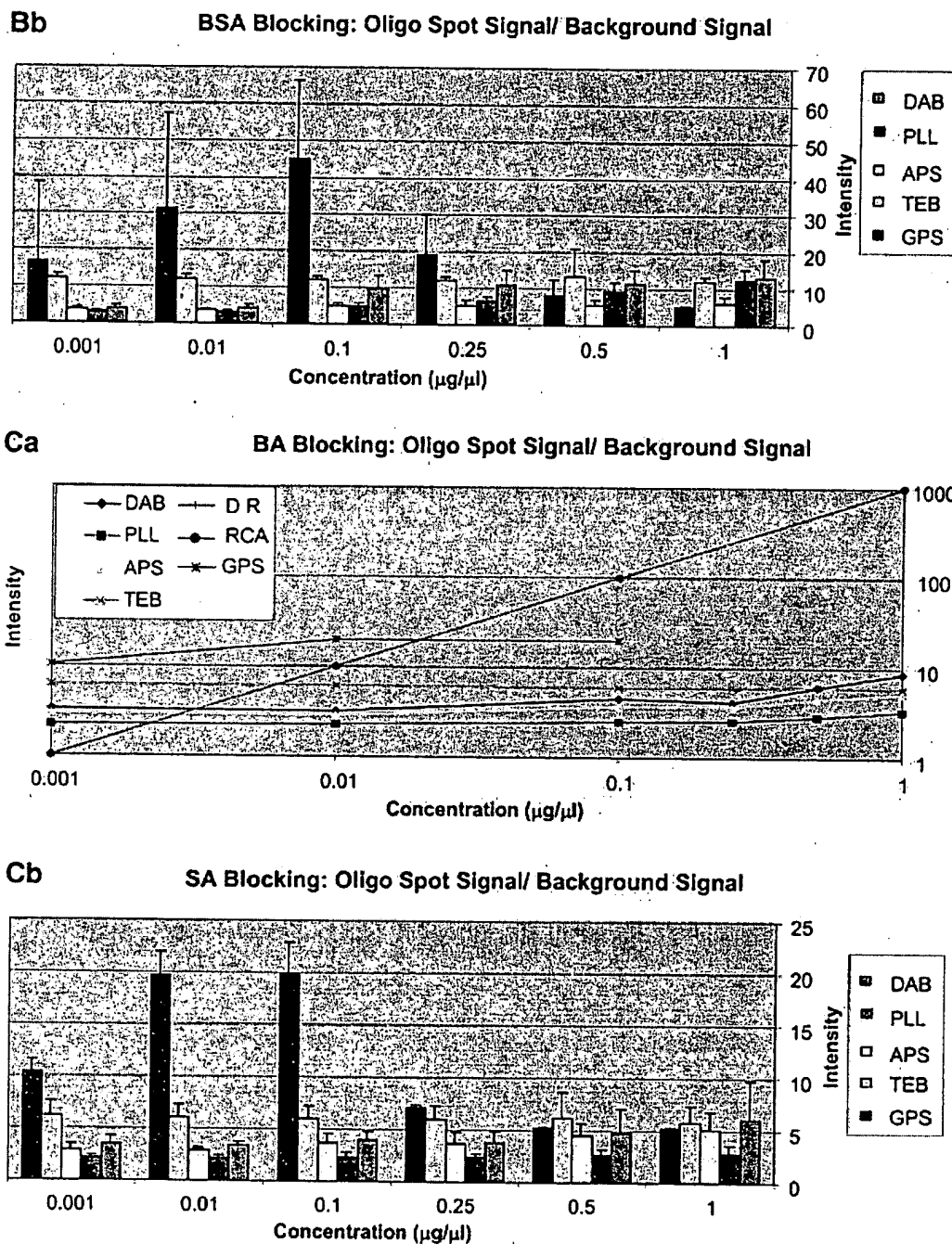

Figure 6. (Previous page and above) Plots of the signal intensity (spot/background) as a function of oligonucleotide DNA concentration at the various microarray surfaces employing: (A) unblocked, (B) BSA blocked, (C) SA blocked [(a) xy graph, (b) bar chart with standard deviation].

impacted background fluorescence and spot quality of all amine-modified surfaces. Conversely, background intensities of amine-modified surfaces that were unblocked and BSA-blocked performed better than corresponding SA-blocked slides. The background intensity of unblocked, amine-modified microarrays was ~2-fold higher than that of BSA-blocked, amine-modified microarrays. This testifies to the possible value of BSA blocking on amine-modified surfaces. The

consequence of this 2-fold difference in background intensity between unblocked (~2000 counts) and BSA-blocked (~4000 counts) amine-modified microarrays was not great as the BSA-blocked background was <4000 counts, and typical spot intensities were >20 000 counts. The blocking strategy employed was observed to have the least effect on the non-amine surfaces, epoxy and RCA respectively. This leads to three important observations: (i) blocking is not necessary for

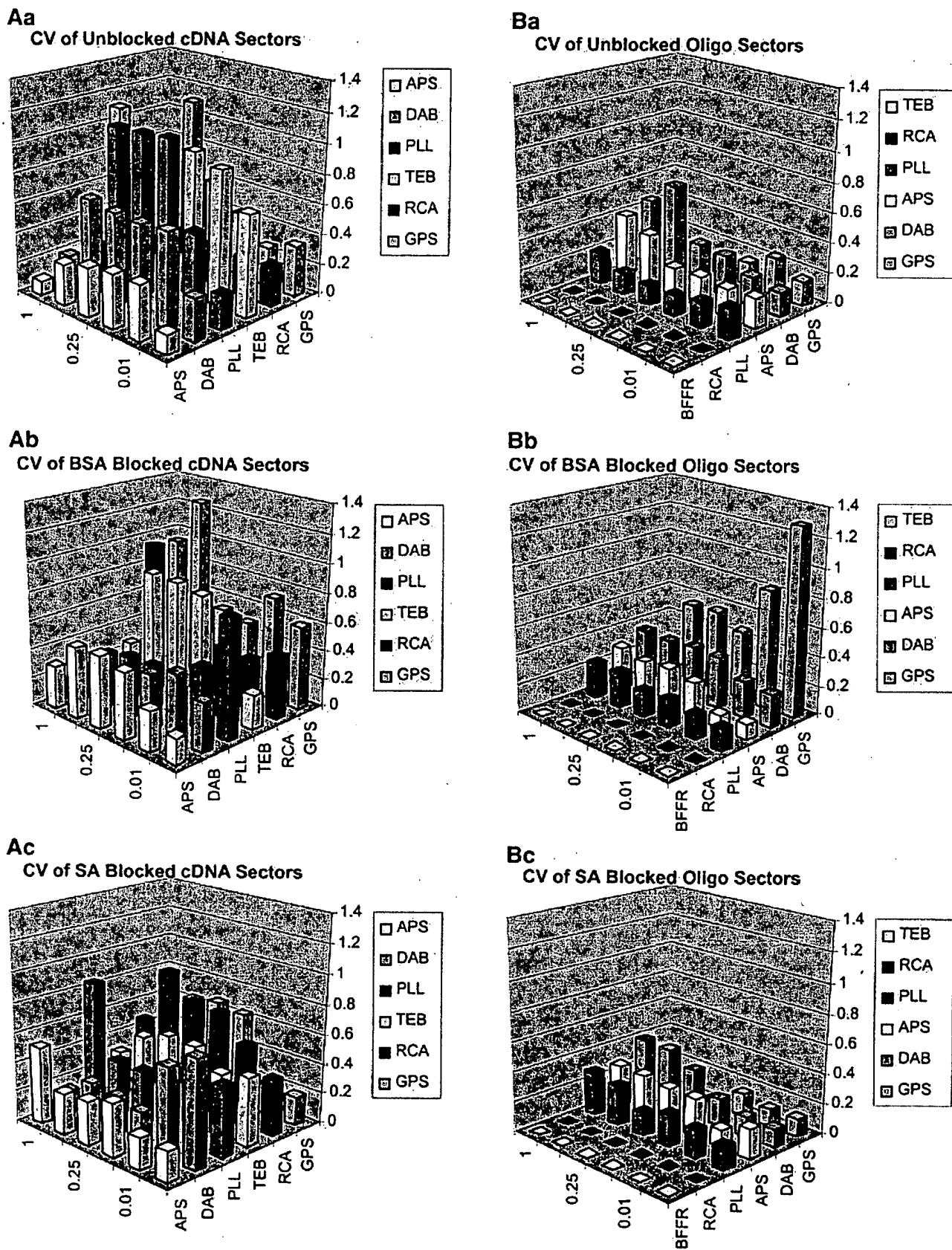

Figure 7. (A) CV of signal intensity values for cDNA sectors. (a) CV for unblocked slides, (b) CV for BSA-blocked slides, (c) CV for SA-blocked slides. (B) CV of signal intensity values for oligonucleotide sectors. (a) CV for unblocked slides, (b) CV for BSA-blocked slides, (c) CV for SA-blocked slides.



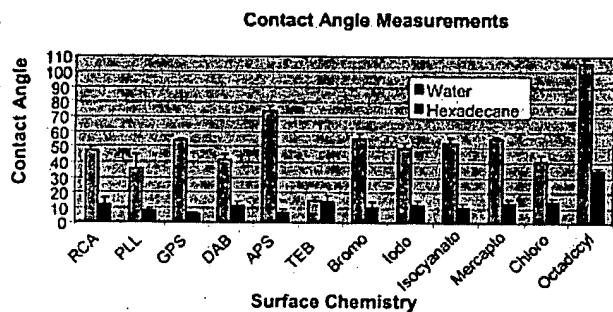

Figure 8. Bar chart showing contact angle measurements for the surfaces chosen for this experiment using ultrapure water (light grey) and hexadecane (dark grey). Note that RCA-cleaned surfaces are comparably hydrophobic compared with the functionalized.

amine surfaces but does reduce slide background when the BSA blocking method is used, (ii) blocking on epoxy and RCA slides produced no apparent reduction in background intensity (Fig. 2A–C) and (iii) SA contributes to high background intensities, particularly when high concentrations of DNA are spotted.

In summary, blocking with SA resulted in the overall highest background intensity in the cDNA and oligonucleotide sectors. BSA-blocked and unblocked microarrays performed comparably, with BSA-blocked microarrays yielding about one-half the signal intensity as the unblocked group for the amine-modified surfaces. The non-amine surfaces were the least affected by blocking method showing relatively constant background intensity regardless of blocking method used.

### Signal intensities

In this work, signal intensities were computed as the ratio of spot intensity to slide background intensity. One anomalous feature that negatively impacts background and spot quality is the presence of comet tails, tapering streaks of hybridized DNA originating from microarray spots. Various research groups have noted comet tails and their impact on signal intensity (22,23, Oregon State Microarray Laboratory: <http://www.cgrb.orst.edu/CSL/custom.pdf>). These and other groups have asserted numerous explanations for the presence of comet tails, e.g. (i) shaking in the blocking solution should be more vigorous, (ii) the spotting concentrations were too high and (iii) there was rough application of the cover slip prior to hybridization. In our experiments, only spots that ranged from 250 ng/ $\mu$ l to 1  $\mu$ g/ $\mu$ l exhibited the comet tails. This supports the notion that this feature arises from excessive spotting concentration. However, this feature developed in conjunction with our use of an automated hybridization station, eliminating the need for cover slips and thus suggesting that cover slip application is not a particular cause. Moreover, comet tails were found principally on microarrays that were blocked with SA suggesting that the choice of blocking agent is an important contributor to the development of this feature. The finding that raw intensity values for cDNA sectors were not surface chemistry dependent implies that all surfaces capture the cDNA with similar efficacy. The principal difference is in the amount of background fluorescence emitted by the various surfaces.

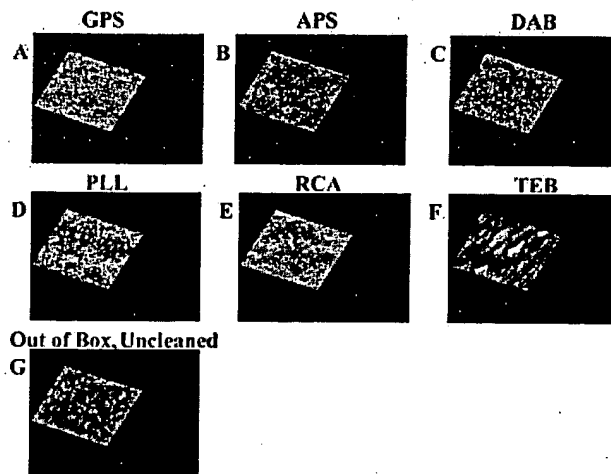

Figure 9. Atomic force micrographs of chemically modified glass surfaces: (A) GPS, (B) APS, (C) DAB, (D) PLL, (E) RCA, (F) TEB, (G) uncleaned, out of box.

### Spotting concentration

Variations in the spotting concentration were aimed at identifying the most suitable concentration for spotting of oligonucleotides and cDNA under the aggregate conditions of surface chemistry, blocking chemistry and method of fixation used in this work. The slope of the signal versus concentration plots is an indication of the dynamic range of the analytical method. On each plot (Figs 5A–C and 6A–C) is shown the expected dynamic range curve. For the cDNA sectors of the microarrays good agreement was found only between 0.01 and 0.1  $\mu$ g/ $\mu$ l on the BSA-blocked slides. The SA-blocked microarrays did not produce agreement over any concentration range. When unblocked, the cDNA sectors of the microarrays showed good agreement with the DR line only on the GPS surfaces. The GPS surface likewise was the only surface under BSA-blocked conditions to have good DR slope matching between 0.01 and 0.5  $\mu$ g/ $\mu$ l. All remaining signal intensities plateau between 0.25 and 0.5  $\mu$ g/ $\mu$ l. We conclude that when spotting cDNA the optimal spotting concentration is between 0.1 and 0.5  $\mu$ g/ $\mu$ l. The oligonucleotide sectors of the microarrays showed very poor agreement with the DR line as these were essentially flat as a function of concentration. This we believe is the result of the washing away of excess oligonucleotides from the surface during hybridization leaving behind a finite adsorbed layer, the thickness of which is only modestly influenced by surface chemistry but is dramatically influenced by fixing method. Hence the GPS surface displays a larger signal when compared with the amine-modified surfaces (APS, PLL and DAB).

### Spot quality and reproducibility

The coefficient of variation was greatest among cDNA sectors of the DNA microarrays. The differences in magnitude of the CV between cDNA and oligonucleotide sectors is likely due to the inherent variability in the fixing methods that dominate immobilization of these two types of DNA to surfaces. The UV cross-linking reaction that dominates the fixing of cDNA promotes inter- and intra-chain cross links that are formed in

the solid state. This is likely a highly variable and poorly controlled reaction and so will give rise to considerable variability from spot to spot. There appears to be no systematic difference in this variability among spots of different cDNA concentration, reinforcing the view that the variability is not linked to the amount of cDNA deposited and is likely derived from an extrinsic factor such as UV crosslinking. Oligonucleotide sectors show considerably less variability. This is likely due to the fact that a finite layer of adsorbed oligonucleotides dominates the spot signal regardless of the surface chemistry or concentration applied. Even when covalently immobilized on GPS and displaying a larger signal relative to other surfaces, the variability is still quite low. The blocking with BSA creates the signal deviation in this case and produces increased variability among oligonucleotide spots, especially on GPS-modified surfaces. The source of the variation was investigated by plotting the signal averages of each sub-array, combined sub-arrays for a given slide, and all sub-arrays on all slides. It was noted that the variability remained essentially constant and was not simply a function of the differences between individual spots, spots in sub-arrays or groups of slides, rather it seemed to be intrinsic.

#### cDNA versus oligonucleotides

Overall, cDNA sectors yielded higher raw spot intensity values (Fig. 4A) and higher signals (Fig. 5A-C) than oligonucleotide sectors when spotted at the same concentration. Also, cDNA displayed higher spot signal variability when compared with oligonucleotides. When studied over the various surfaces, the raw spot intensities of cDNA spots were more tightly distributed than those of oligonucleotides. That is, for cDNA, the surface chemistry had less impact on the magnitude of the spot intensity. Again, this reflects the greater importance of UV crosslinking as a fixative over chemisorption as the immobilization principle.

Oligonucleotides showed the highest raw spot intensity, lowest background intensity and consequently the highest signal on GPS surfaces. The optimal spotting concentration was found to be 0.1  $\mu\text{g}/\mu\text{l}$  ( $\sim 10 \mu\text{M}$  for a 30mer and  $\sim 5 \mu\text{M}$  for a 60mer). Similarly, cDNA showed the highest raw spot intensity on DAB- and PLL-modified surfaces reflecting strong interaction with amine-modified surfaces. This is particularly evident at low spotting concentrations. However, among the chemically modified surfaces, GPS gave the lowest background, regardless of the blocking method used. Because of this low background, GPS-modified surfaces resulted in superior signal intensities for cDNA, being better than either DAB- or PLL-modified surfaces. This does not appear to be the contribution of covalent coupling of the 5'-amine-terminated cDNA to the GPS surface.

The differences between oligonucleotide and cDNA intensity values for the same surface chemistry were greater over all surfaces ( $\sim 4$ - $8$ -fold) except for GPS, where the difference was  $\sim 2$ -fold at 0.1  $\mu\text{g}/\mu\text{l}$ . This is likely due to the difference in immobilization chemistry, recalling that all surfaces except GPS were cross-linked with 90  $\text{mJ}/\text{cm}^2$  of UV. However, cDNA spotted on epoxy surfaces was similar in intensity to cDNA printed on the amine surfaces suggesting that UV crosslinking and epoxy-amine coupling immobilize a similar amount of cDNA.

#### UV crosslinking

On all amine-modified surfaces, intensity values for oligonucleotide sectors were consistently  $\geq 4$ -fold than the intensity from corresponding cDNA sectors. For instance, at 0.1  $\mu\text{g}/\mu\text{l}$ , oligonucleotide sectors on PLL-modified surfaces showed  $\sim 4$ -fold less intensity than cDNA sectors. On APS-modified surfaces this was  $\sim 5$ -fold less and on DAB-modified surfaces this was  $\sim 8$ -fold less intensity. This trend was similar across all concentrations of DNA. Spotting on the amine surfaces was followed by UV crosslinking and baking. However, the GPS surfaces did not undergo this fixation protocol. Spotted GPS slides were incubated at 42°C for 8 h to promote amine-to-epoxide coupling reaction and subsequently washed. The cDNA sectors from these slides were also brighter, but by only  $\sim 2$ -fold. This seems to indicate that UV irradiation effects the fixing of cDNA differently than it does oligonucleotides.

This explanation, however, does not fully account for the magnitude of intensity difference observed between the amine versus the epoxy surfaces. It should be noted that the cDNA was  $\sim 600$  bp in length, while the oligonucleotides were only 30 bases in length. It follows that there were fewer strands of cDNA per unit volume than oligonucleotides, yet the intensity was as much as 8-fold greater from cDNA sectors. Theoretically, cDNA 600 bp in length can bind more than one strand of labeled PCR product. Although our control for non-specific DNA interaction (non-homologous genomic DNA) showed little to no intensity, non-specific interaction could have possibly added somewhat to the spot intensity. In addition, the intensity disparity between oligonucleotides and cDNA could be a consequence of a lower hybridization sensitivity of 30mer oligonucleotides compared with 600 bp cDNA when labeled PCR product is used as the hybridization target.

The potential for covalent coupling of the amine-terminated primer-derived PCR product to GPS surfaces did not influence the performance of cDNA. UV cross-linking was a more significant fixative than covalent coupling for cDNA. It is noteworthy that UV-treated slides all displayed higher background intensities relative to the un-irradiated slides, which had low background intensities (GPS). UV irradiation is well known to bring up color centers within glass (24). This enhances autofluorescence of the substrate, increasing its background intensity.

GPS surfaces offer the greatest versatility for DNA immobilization. These surfaces offer high signal values with amine-terminated oligonucleotides and confer superior signal to cDNA. In the former case this advantage arises when covalent coupling of the oligonucleotide to the surface is promoted with the use of amine-functionalized oligonucleotides. In the latter case, this advantage arises because of the generally lower background intensity of the substrate as UV crosslinking is rendered unnecessary and so exposure to UV does not bring up the autofluorescence centers within the glass. Blocking as an approach to reduce non-specific adsorption of labeled target is not required or necessary. Where blocking must be pursued, BSA confers the lowest background intensity values and represents some modest improvement of the unblocked condition. SA provokes comet tail formation, particularly at higher spotting concentrations, and should be avoided. The most appropriate spotting

concentration on GPS surfaces was found to be 0.1  $\mu\text{g}/\mu\text{l}$  (10  $\mu\text{mol}$ ) for oligonucleotides and between 0.01 and 0.1  $\mu\text{g}/\mu\text{l}$  for cDNA.

## ACKNOWLEDGEMENTS

The authors wish to thank the VCU Center for Bioelectronics, Biosensors and Biochips (C3B), the Virginia Center for Innovative Technology (CIT BIO-99-010) and the Commonwealth of Virginia VA Commonwealth Technology Research Fund for Cancer Genomics and Development of Diagnostic Tools and Therapies (grant no. SE2002-02).

## REFERENCES

- Blohm, D.H. and Guiseppi-Elie, A. (2001) New developments in microarray technology. *Curr. Opin. Biotech.*, **12**, 41–47.
- Kane, M.D., Jatke, T.A., Stumpf, C.R., Lu, J., Thomas, J.D. and Madore, S.J. (2000) Assessment of the sensitivity and specificity of oligonucleotide (50mer) microarrays. *Nucleic Acids Res.*, **28**, 4552–4557.
- Hegde, P., Qi, R., Abernathy, K., Gay, C., Dharap, S., Gaspard, R., Hughes, J.E., Snesrud, E., Lee, N. and Quackenbush, J. (2000) A concise guide to cDNA microarray analysis. *Biotechniques*, **29**, 548–550.
- Rickman, D., Bobek, M., Misk, D., Kuick, R., Blaivas, M., Kurnit, D., Taylor, J. and Hanash, S. (2001) Distinctive molecular profiles of high-grade and low-grade gliomas based on oligonucleotide microarray analysis. *Cancer Res.*, **61**, 6885–6891.
- Lindroos, K., Liljedahl, U., Raitio, M. and Syvanen, A. (2001) Minisequencing on oligonucleotide microarrays: comparison of immobilization chemistries. *Nucleic Acids Res.*, **29**, e69.
- Benters, R., Niemeyer, C.M., Drutschmann, D., Blohm, D. and Wohrle, D. (2002) DNA microarrays with PAMAM dendritic linker systems. *Nucleic Acids Res.*, **30**, e10.
- Zammatteo, N., Jeanmart, L., Hamels, S., Courtois, S., Louette, P., Hevesi, L. and Remacle, J. (2000) Comparison between different strategies of covalent attachment of DNA to glass surfaces to build DNA microarrays. *Anal. Biochem.*, **280**, 143–150.
- Dolan, P., Wu, W., Ista, L., Metzberg, R., Nelson, M. and Lopez, G. (2001) Robust and efficient synthetic method for forming DNA microarrays. *Nucleic Acids Res.*, **29**, e10.
- Call, D., Chandler, D. and Brockman, F. (2001) Fabrication of DNA microarrays using unmodified oligonucleotide probes. *Biotechniques*, **30**, 368–379.
- Brazma, A., Hingamp, P., Quackenbush, J., Sherlock, G., Spellman, P., Stoeckert, C., Aach, J., Ansorge, W., Ball, C.A., Causton, H.C., Gaasterland, T., Glenisson, P., Holstege, F.C., Kim, I.F., Markowitz, V., Matise, J.C., Parkinson, H., Robinson, A., Sarkans, U., Schulze-Kremer, S., Stewart, J., Taylor, R., Vilo, J. and Vingron, M. (2001) Minimum information about a microarray experiment (MIAME)-toward standards for microarray data. *Nature Genet.*, **29**, 365–371.
- Wolfinger, D.R., Gibson, G., Wolfinger, D.E., Bennett, L., Hamadeh, H., Bushel, P., Afshari, C. and Paules, S.R. (2001) Assessing gene significance from cDNA microarray expression data via mixed models. *J. Comp. Biol.*, **8**, 625–637.
- Diehl, F., Grahlmann, S., Beier, M. and Hoheisel, J.D. (2001) Manufacturing DNA microarrays of high spot homogeneity and reduced background signal. *Nucleic Acids Res.*, **29**, e38.
- Wang, X., Ghosh, S. and Guo, S.W. (2001) Quantitative quality control in microarray image processing and data acquisition. *Nucleic Acids Res.*, **29**, e75.
- Schena, M., Shalon, D., Davis, R.W. and Brown, P.O. (1995) Quantitative monitoring of gene expression patterns with a complementary DNA microarray. *Science*, **270**, 467–470.
- Sorribas, H., Braun, D., Leder, L., Sonderegger, P. and Tiefenauer, L. (2001) Adhesion proteins for a tight neuron-electrode contact. *J. Neurosci. Meth.*, **104**, 133–141.
- Ho, M. (1993) Characterization of the structure and bonding of adsorbates on model silica surfaces. PhD Thesis, Pennsylvania State University.
- Guiseppi-Elie, A., Wilson, A.M., Tour, J.M., Brockmann, T.W., Zhang, P. and Allara, D.L. (1995) Specific immobilization of electropolymerized polypyrrole thin films onto interdigitated microsensor array electrodes. *Langmuir*, **11**, 1745–1768.
- Kim, H.J., Moon, J.H. and Park, J.W. (2000) A hyperbranched poly(ethyleneimine) grown on surfaces. *Journal Colloid. Interface Science*, **227**, 247–249.
- Gheorghe, M. and Guiseppi-Elie, A. (2003) Electrical frequency dependent characterization of DNA hybridization. *Biosensors Bioelectronics*, in press.
- Liau, L., Lallone, R., Seitz, R., Buznikov, A., Gregg, J., Kornblum, H., Nelson, S. and Bronstein, J. (2000) Identification of human glioma-associated growth factor gene, granulin, using differential immunosorption. *Cancer Res.*, **60**, 1353–1360.
- Lamture, B., Beattiek, K., Burke, B., Eggers, M., Ehrlich, D., Fowler, R., Hollis, M., Kosicki, B., Reich, R. and Smith, S. (1994) Direct detection of nucleic acid hybridization on the surface of a charge coupled device. *Nucleic Acids Res.*, **22**, 4710–4714.
- Yang, Y.H., Buckley, M., Dudoit, S. and Speed, T. (2000) Comparison of methods for image analysis on cDNA microarray data. *Technical Report 584*. <http://stat-www.berkeley.edu/users/terry/zarray/Html/image.html>.
- Latto, D. and Boucher, C. (2000) Microarray Gene Expression Profiling: The Basics. BioNote MG002 v1.0. BioRobotics Inc., Woburn, MA, USA. pp. 24. [http://www.biorobotics.com/Users/downloads/BioNoteMG002\\_V1.0.pdf](http://www.biorobotics.com/Users/downloads/BioNoteMG002_V1.0.pdf).
- Exarhos, G.J. (1984) Vibrational raman studies of particle induced damage in oxide glasses. *Nuclear Instruments Meth. Phys. Res.*, **1**, 498–502.

## DNA microarray synthesis by using PDMS molecular stamp (II)

— Oligonucleotide on-chip synthesis using PDMS stamp

XIAO Pengfeng (肖鹏峰)<sup>1</sup>, HE Nongyue (何农跃)<sup>1</sup>, HE Quanguo (贺全国)<sup>1</sup>,  
ZHANG Chunxiu (张春秀)<sup>1</sup>, WANG Yiwu (王轶文)<sup>1</sup>, LU Zuhong (陆祖宏)<sup>1</sup>  
& XU Jiqing (徐吉庆)<sup>2</sup>

1. Key Laboratory for Molecular and Biomolecular Electronics of Ministry of Education, Southeast University, Nanjing 210096, China;

2. Nanjing E-life Gene Medicine Ltd., Nanjing 210016, China

Correspondence should be addressed to Lu Zuhong (email: zhlu@seu.edu.cn)

Received April 12, 2001

**Abstract** Based on the standard phosphoramidites chemistry protocol, two oligonucleotides synthetic routes were studied by contact stamping reactants to a modified glass slide. Route A was a contact coupling reaction, in which a nucleoside monomer was transferred and coupled to reactive groups (OH) on a substrate by spreading the nucleoside activated with tetrazole on a polydimethylsiloxane (PDMS) stamp. Route B was a contact detritylation, in which one nucleoside was fixed on the desired synthesis regions where dimethoxytrityl (DMT) protecting groups on the 5'-hydroxyl of the support-bound nucleoside were removed by stamping trichloroacetic acid (TCA) distributed on features on a PDMS stamp. Experiments showed that the synthetic yield and the reaction speed of route A were higher than those of route B. It was shown that 20 mer oligonucleotide arrays immobilized on the glass slide were successfully synthesized using the PDMS stamps, and the coupling efficiency showed no difference between the PDMS stamping and the conventional synthesis methods.

**Keywords:** PDMS stamps, contact coupling, contact detritylation, oligonucleotide synthesis.

Oligonucleotide arrays attracted much attention in the past decade, which have been proved to be the powerful tools for monitoring gene expression, resequencing genes to screen for mutations and polymorphism by hybridization<sup>[1-3]</sup>. The preparation of the oligonucleotide microarray can be generally classified into two different methods. One is to synthesize each oligonucleotide separately and spot each probe on the solid chip surface. The other is to directly synthesize the different oligonucleotide probes on the chip surface at the same time. Several on-chip synthesis methods of oligonucleotide arrays have been reported<sup>[4-6]</sup>. For example, Fodor et al.<sup>[4]</sup> developed light-directed synthesis for the construction of high-density DNA probe arrays by using photolithography and solid-phase DNA synthesis. Affymetrix Corporation has achieved probe arrays with high spatial resolution. Our group has proposed an on-chip synthesis technology to fabricate the oligonucleotide arrays based on the molecular stamp and conventional DNA synthesis method<sup>[1,7]</sup>. Molecular stamp technology can also be called soft lithography initially developed by

Whiteside group<sup>[8]</sup>, which can achieve sub-microstructure (the spatial resolution of features of the PDMS stamp could reach up to  $0.2 \mu\text{m} \times 0.2 \mu\text{m}$ ). Main advantages for soft lithography are simple and reliable operation. Once the stamp is available, multiple copies of the pattern can be produced using straightforward experimental techniques.

## 1 Experimental

### 1.1 Principle of the molecular stamp method

The basic strategy for the molecular stamping oligonucleotide synthesis accords with the standard phosphoramidites chemistry protocol<sup>[9,10]</sup>, as illustrated in figs. 1 and 2. Two synthesis routes including the contact coupling and the contact detritylation were put forward together. In the former route, according to the order of A, G, C and T, the mixed acetonitrile solution with nucleoside monomer and tetrazole as reactants was spread on features of the PDMS stamp, then transferred onto the modified substrate surface by stamping until acetonitrile was vaporized nearly to dryness, therefore the nucleoside monomer on features of the stamp was coupled with the

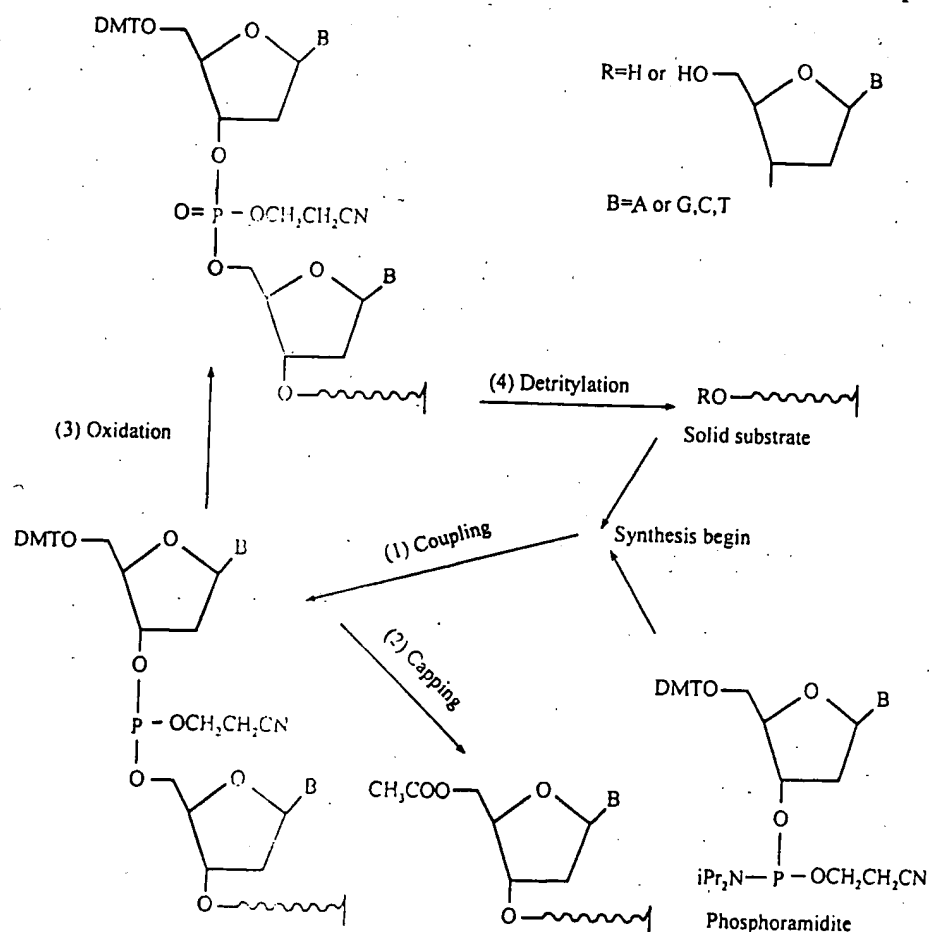

Fig. 1. Schematic illustration of solid-phase oligonucleotide *in situ* synthesis.

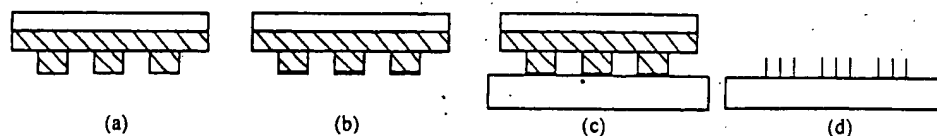

Fig. 2. Schematic illustration of a contact stamping reaction. (a) Stamp, (b) spreading reagents, (c) contact stamping, (d) reactants bonding on the substrate.

predefined regions on the substrate. According to the above-described details, all different nucleosides (A, G, C, T) were coupled respectively on their predefined regions by changing different stamps and their corresponding monomer. Next, oxidation, capping, and detritylation conducted successively in a sealed reactor after four contact couplings completed. The four reactions (oxidation, capping, and detritylation followed four contact couplings) comprise a cycle, by changing different nucleoside monomers and its corresponding stamp, the cycles were repeated until the predefined oligonucleotide arrays were synthesized. Accordingly, 20 mer oligonucleotide arrays require 80 PDMS stamps and each stamp has specific features. In the second route, reactants spreading on the stamps were TCA in  $\text{CHCl}_3$ . Consequently, DMT groups were removed and 5'-hydroxyl groups were created on the stamped regions. While other regions of the substrate remained inactive since they were still blocked with DMT groups. After each detritylation was completed, the excessive TCA reagent was violently washed away with acetonitrile. The corresponding nucleoside was coupled on the detritylated region, and the followed detritylations and couplings were conducted on different regions of the substrate by selecting stamps with different features. In this case one-layer nucleosides must conduct four contact detritylations and four couplings. Then oxidation and capping were conducted in a sealed reactor. As the above-described process, oligonucleotide arrays were synthesized until all nucleosides of oligonucleotides were coupled.

## 1.2 Materials and methods

Fluorescein phosphoramidite (fluoreprime and fluoremonomer), 5'-DMT-2'-deoxynucleoside phosphoramidites (thymidine,  $N^4$ -isobutyryl-2'-deoxycytosine,  $N^2$ -isobutyryl-2'-deoxyguanosine,  $N^6$ -phenoxyacetyl-2'-deoxyadenosine), the other synthesis reagents and solvents except oxidation agent (see table 1) were purchased from PE Biosystems. The glass substrates used for the coupling reaction were standard "precleaned" soda lime microscope slides purchased from the local stores. The commercially available polydimethylsiloxane was obtained from Hangzhou Silicone Rubber Plant. Other chemical reagents were analytic grade and purchased from the local stores.

1.2.1 The modification of the glass slide<sup>[11]</sup>. A general sodium silicate glass slide was treated in  $\text{H}_2\text{SO}_4$ - $\text{K}_2\text{Cr}_2\text{O}_7$  solution for 24 h, and strongly washed with tap water and distilled water, then immersed in 5% 3-aminopropyltriethoxysilane with  $\text{CH}_3\text{Cl}$  for 5 min, washed successively with

$\text{CH}_3\text{CH}_2\text{OCH}_2\text{CH}_3$ ,  $\text{CH}_3\text{COCH}_3$ , and anhydrous ethanol, and dried at  $110^\circ\text{C}$  for 30 min. The slide was treated with 5% glutaraldehyde in phosphate buffered saline (PBS) ( $\text{pH} = 7.4$ ) for 2 h, 10%  $\text{NH}_2\text{C}_2\text{H}_4\text{OH}$  for 2 h, and  $\text{NaBH}_4$  solution for 15 min at ambient temperature respectively. The modified glass slide was dried at  $110^\circ\text{C}$  for 30 min for oligonucleotides synthesis.

1.2.2 Preparation of the PDMS stamps<sup>[12]</sup>. Motherboards of stamps were made by lithography as described elsewhere. By casting a mixed prepolymer including catalyst, ethylene silicate, and polydimethylsiloxane onto the motherboard whose surface had been lithographed, removing the bubbles in the prepolymer, and then covering the silanized glass slide on the mixed precursor, the sandwiched prepolymer was left to cure. After that, the motherboard was peeled off from the elastic cured polymer, so the stamp was fabricated. Then it was plasma-treated until hydrophilic surface formed, and the stamp could be further used for oligonucleotide synthesis.

1.2.3 Oligonucleotides synthesis. The synthesis was conducted in a glove-box (Mecaplex, Switzerland) as detailed in table 1, and the concentrations (by volume) of  $\text{H}_2\text{O}$  and  $\text{O}_2$  in the glove-box were below 0.0002% and 0.0015% respectively. Two kinds of oligonucleotide sequences were synthesized, one was poly  $T_{(n)}$  ( $n$  is the number of base) and its final nucleoside was fluorescent deoxynucleoside phosphoramidite; the other was 3'-GGA CTC TCT GAA TCG GAG GA ( $P_{2c}$ ).

Table 1. Conditions of oligonucleotide synthesis

Step	Reagents or solvent	Time/s
Washing	acetonitrile	50
Coupling	$0.1 \text{ mol} \cdot \text{L}^{-1}$ phosphoramidite + $0.5 \text{ mol} \cdot \text{L}^{-1}$ tetrazole in acetonitrile	100
Washing	acetonitrile	30
Capping (I+II)	$\text{Ac}_2\text{O}$ /pyridine/ <i>N</i> -methylimidazole in THF	30
Washing	acetonitrile	30
Oxidation	$0.1 \text{ mol} \cdot \text{L}^{-1}$ $\text{I}_2$ / $\text{Ac}_2\text{O}$ / $\text{AcOH}$ / pyridine / THF	30
Washing	acetonitrile	100
Detritylation	3% TBAH in $\text{CHCl}_3$	50

1.2.4 The deprotection, hybridization and detection of synthetic oligonucleotides. After the synthesis completion, the glass slide was shaken in a mixed solution of ethanol and ethanol amine (vol/vol=1) in a sealed box at  $75^\circ\text{C}$  for 2 h for deprotection. Then it was washed with distilled water and dried by cold blowing before detection or hybridization. Oligonucleotides or oligonucleotide arrays were hybridized in 200 nmol/L 5'-CCT GAG AGA CTT AGC CTC CT-FAM probe solution at  $55^\circ\text{C}$  for 1.5 h in the hybridization chamber, and then rinsed with 0.1% sodium dodecyl sulfate (SDS) in 6×SSC (sodium chloride/sodium citrate buffer), 0.1% SDS in  $0.1 \times \text{SSC}$  respectively. The fluorescence signal of the surface was imaged by a scanning laser confocal fluorescence microscope (TCS/SP, Leica, Germany) and its fluorescence intensity was dealt with

software downloaded from Scion Corporation. Because the relation of the fluorescence intensity to the density of oligonucleotides was not clear in our current work, the fluorescence intensity ratio of synthetic regions to non-synthetic regions was defined as a relative fluorescence intensity (RFI) to provide a measure of the coupling efficiency or related synthesis yield.

## 2 Results and discussion

### 2.1 Contact stamping reactions on the modified glass slide

Two routes were put forward and investigated to explore the feasibility of contact stamping reactions for oligonucleotide synthesis. Advantages and shortcomings of the contact coupling and the contact detritylation were described as follows: The contact coupling route had a shorter synthesis than the contact detritylation method, and each cycle consisted of four contact couplings, a capping, an oxidation and a detritylation. Reactants spread on four stamps were four different nucleoside monomers. While the latter route requires only one reactant spread on features of different stamps, as each cycle consists of four contact detritylation, four couplings, a capping and an oxidation, and it requires more complicated procedures. Figs. 3(a) and (b) are the fluorescence images of sequence  $T_{12}$ -FAM synthesized by the contact coupling and by the contact detritylation, and their RFI values are 19.6 and 11.7 respectively. It is clearly shown that two routes of the contact stamping reaction are feasible. However, the RFI value of oligonucleotide synthesized by the contact coupling was greater than that by the contact detritylation, showing that the former coupling efficiency is higher than the latter, which could be explained by the nature of those reactions. The coupling reaction is quantitative and rapid, while the detritylation is an equilibrium reaction which could not be conducted completely without acidic reagents rinsing<sup>[13,14]</sup>. Moreover, the contact detritylation procedures are more complicated than the contact coupling practically. Therefore, the contact coupling route was chosen for oligonucleotides synthesis.

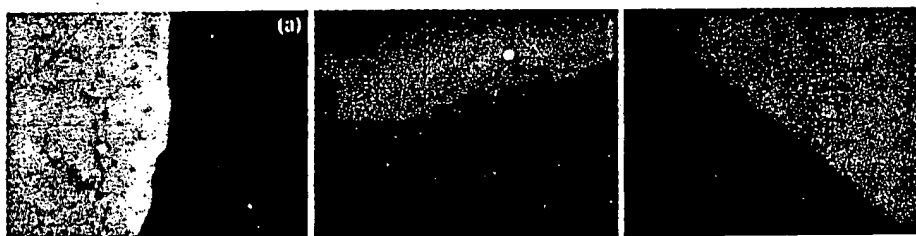

Fig. 3. Laser confocal fluorescence microscopy images of poly T on-chip synthesized by contact stamping reactions. (a) and (c) Contact coupling ( $T_{12}$ -FAM); (b) contact detritylation ( $T_{20}$ -FAM).

The influence of contact stamping times on the synthesis efficiency for the contact coupling route was investigated. The experiment shows that the efficiency and its intensity uniformity for double contact stampings are better than stamping once; while stamping three times or more, the efficiency is not improved significantly in comparison with double contact stampings. As a result, double contacting stampings were employed for each nucleoside lengthening.



An experiment was developed to explore the contact coupling efficiency, in which the terminal nucleoside was coupled (to 5'-hydroxyl groups) and oxidized without succeeding capping and detritylation, then an FAM-labeled nucleoside was coupled to the uncoupled 5'-hydroxyl groups. Naturally, the fluorescence signal could be observed and measured with the addition of FAM-labeled nucleoside as long as the former coupling was not fully completed. The greater the RFI, the poorer the contact coupling efficiency. As shown in fig. 4, the RFI value equals 1 when the sixth nucleoside is coupled. The result indicates that the coupling efficiency is nearly 100% after the sixth nucleoside coupling; it also indicates that the RFI valued 5.64 of the synthesized sequence  $T_{(20)}$ -FAM in fig. 3(c) was contributed by the correct 20 mer oligonucleotides rather than the failed oligonucleotide fragments.

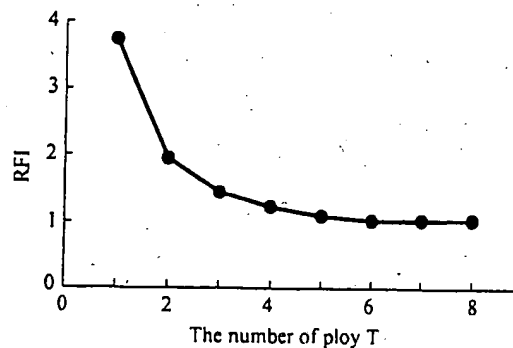

Fig. 4. The relation of average RFI of four parallel examples with the number of ploy T.

## 2.2 The effect of contact printing on the synthetic yield

On the different regions of the same slide, the same sequence oligonucleotides were synthesized by using the contact coupling and the directly drip-dropped coupling. The fluorescent microscope images of two methods show no significant differences between figs. 5(a) (RFI valued 5.64, i.b.i.d) and (c) (RFI valued 5.90) of  $T_{(20)}$ -FAM sequence or figs. 5(b) (RFI valued 3.91) and (d) (RFI valued 3.87) of  $P_{2C}$  sequence. These results indicate that the effect of contact printing on the synthetic yield is little, which is because reactants of the contact coupling were quasi-solid phase and their consistencies were more concentrated, thus the speed was faster than that of the direct coupling although reactants of the later had more capacity.

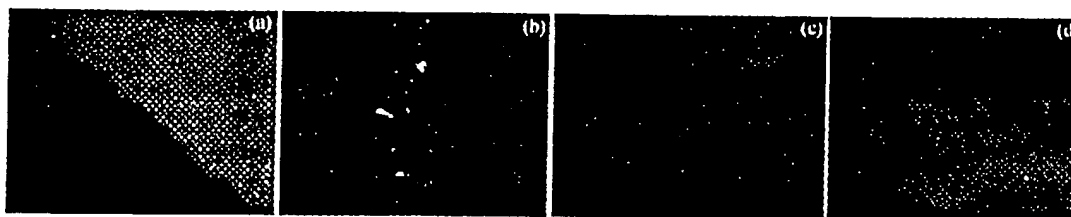

Fig. 5. Laser confocal fluorescence microscopy images of 20 mer oligonucleotides *in situ* synthesized. Contact couplings: (a)  $T_{(20)}$ -FAM; (b)  $P_{2C}$ ; direct couplings: (c)  $T_{(20)}$ -FAM; (d)  $P_{2C}$ .

## 2.3 Synthesis of oligonucleotide arrays

Oligonucleotide arrays with the two same sequences  $T_{(20)}$ -FAM and  $P_{2C}$  were synthesized by using the molecular stamp method and the fluorescence images are shown in fig. 6, features in fig. 6(a) are round with the diameter of  $3.0 \times 10^{-5}$  m, and 1  $\text{cm}^2$ -sized chip arrays had 65536 fea-

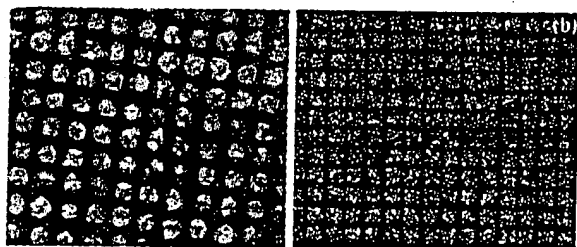

Fig. 6. Laser confocal fluorescence microscopy images of oligonucleotide arrays. (a)  $T_{(20)}$ -FAM; (b)  $P_{2c}$ .

tures; while features in fig. 6(b) of  $P_{2c}$  are  $9.0 \times 10^{-5} \text{ m} \times 9.0 \times 10^{-5} \text{ m}$  rectangle and  $1 \text{ cm}^2$ - sized chip arrays had 10000 features. The fluorescence signal was contributed by the full 20 mer oligonucleotide of the  $T_{(20)}$ -FAM sequence as a result of capping process in synthesis, which gave the evidence that the total efficiency of on-chip synthesis for 20 mer DNA sequence was

satisfied. The hybridization result for  $P_{2c}$  array gave the same conclusion.

**Acknowledgements** This work was supported by the National 863 High-Tech Project, 973 National Key Fundamental Research Project and the National Natural Science Foundation of China (Grant No. 60071001).

## References

1. Lu Zuhong, The study, development, and application of bio-chips, *Electronic Technological Report*, 1998, 11: 1—5.
2. Gerhold, D., Rushmore, T., Caskey, C. T., DNA chips: Promising toys have become powerful tools, *Techniques*, 1993, 3: 168—173.
3. Khan, J., Bitter, N. L., Chen, Y. D. et al., DNA microarray technology: The anticipated impact on the study of human disease, *Biochimica et Biophysica Acta*, 1999, 1423: 17—28.
4. Fodor, S. P. A., Read, J. L., Pirruny, M. C. et al., Light-directed, spatially addressable parallel chemical synthesis, *Science*, 1991, 251: 767—773.
5. Schena, M., DNA microarrays, New York: Oxford University Press, 1999, 85—97.
6. Ma Liren, Jiang Zonghua, Bio-chips, Beijing: Chemistry Industry Publishing Company, 2000, 25—47.
7. Lu Zuhong, A method of preparation of compound microarray chips and the compound microarray chips produced according to said method, International Patent, WO99/50770, 1998-04-03.
8. Xia, Y. N., Whitesides, G. M., Soft-lithography, *Angew Chem. Int. Ed.*, 1998, 37: 550—575.
9. Uhlmann, E., Peyman, A., Antisense oligonucleotides: a new therapeutic principle, *Chemical Reviews*, 1990, 90(4): 544—584.
10. Weiler, J., Hoisel, J. D., Combining the preparation of oligonucleotide arrays and synthesis of high-quality primers, *Analytical Biochemistry*, 1996, 243: 218—227.
11. Li Jiong, Wang Hong, Zhao Yujie et al., A kind of versatile linkers for covalent bonding DNA on glass surface, in International Forum on Biochip Technologies (ed. Biochip Research & Development Center), Beijing: Tsinghua University, 2000, 492—494.
12. Xiao Pengfeng, He Nongyue, Lu Zuhong, DNA microarray synthesis using PDMS molecular stamps, I. The fixation and shrinkage of PDMS molecular stamps, *Journal of Southeast University (Natural Science Edition)*, 2001, 2: 6—10.
13. Septak, M., Kinetic studies on depurination and detritylation of CPG-bound intermediates during oligonucleotide synthesis, *Nucleic Acids Research*, 1996, 24(15): 3053—3058.
14. Paul, C. H., Timothy, A. R., Acid binding and detritylation during oligonucleotide synthesis, *Nucleic Acids Research*, 1996, 24(15): 3048—3052.

## Position-specific release of DNA from a chip by using photothermal denaturation

Kazunori Okano <sup>a,\*</sup>, Kenji Yasuda <sup>b</sup>, Shin'ichi Ishiwata <sup>c,d,e,f</sup>

<sup>a</sup> Bio System Research Department, Central Research Laboratory, Hitachi Ltd., Kokubunji, Tokyo 185-8601, Japan

<sup>b</sup> Department of Life Sciences, Graduate School of Arts and Sciences, The University of Tokyo, Tokyo, Japan

<sup>c</sup> Department of Physics, School of Science and Engineering, Japan

<sup>d</sup> Advanced Research Institute for Science and Engineering, Japan

<sup>e</sup> Materials Research Laboratory for Bioscience and Photonics, Waseda University, Japan

<sup>f</sup> Core Research for Evolutional Science and Technology (CREST), "Genetic Programming" Team 13, Japan

### Abstract

A photothermal method to recover specific DNA fragments fixed in place on a DNA chip is described. This method uses infrared (IR) laser irradiation to thermally denature and release specific DNA immobilized in a specific area of a chip. A 1053-nm IR laser beam with an intensity of 10–100 mW is focused on the target area at a resolution of 10  $\mu\text{m}$ , and the DNA fragments are released from the chip surface. We have demonstrated that DNA fragments containing different numbers of base pairs (231–799 bp) fixed in place on the DNA chip can be separately recovered. There are enough quantities of recovered DNA fragments that can be amplified by using polymerase chain reaction (PCR). The photothermal method coupled with the DNA chip can therefore be used in highly sensitive purification of DNA and will have many applications in the DNA chip technology. © 2000 Elsevier Science S.A. All rights reserved.

**Keywords:** DNA chip; Photothermal denaturation; PCR; Infrared laser

### 1. Introduction

The purification of DNA fragments from living cells is a fundamental process in molecular biology and molecular diagnosis. We usually prepare a DNA library constructed from cloned DNA [1]. The cloning method is suitable for preparing a large number of DNA fragments, but is very laborious and time-consuming because of its cultivation processes. Nowadays, molecular biology is moving very rapidly towards the stage of functional genomics in which rapid preparation of different parts of genes will be required [2]. If a DNA library is constructed on a chip and any kind of DNA can be individually recovered from the

chip, the DNA chip will become a very useful method and will change the way DNA-related experiments are done.

DNA chip technology in molecular biology has made rapid progress over the last 10 years [2–11]. Several approaches have been developed for producing DNA chips of different formats. In 1991, Fodor et al. [3] succeeded in making the microchips by photolithography on a solid surface. A chip containing 65,000 different 20-mer oligonucleotides of defined sequence in an area of 1.6  $\text{cm}^2$  was reported in 1996 [2], and it is now possible to assemble 150,000–300,000 oligonucleotides on one microchip [6]. Presynthesized oligonucleotides can be immobilized on a solid surface [5,7,8] or into a gel element fixed on a glass plate [9,10] by spotting the oligonucleotides. Any DNA produced by chemical syntheses, cloning, and polymerase chain reaction (PCR) can be immobilized on the microchip. The gel-fixed microchip has a high capacity for immobilizing oligonucleotides: 50 fmol of oligonucleotides is immobilized per microchip element of size 40  $\times$  40  $\mu\text{m}^2$ . This is more than 100 times higher than immobiliza-

\* Corresponding author. Tel.: +81-423-23-1111; fax: +81-423-27-7833.

E-mail address: okano-k@crl.hitachi.co.jp (K. Okano).

tion capacity of a plane glass surface, and this high capacity increases the hybridization velocity and the dynamic range. DNA microchips have been applied for gene expression analyses [5,11] and detection of single-nucleotide polymorphisms (SNPs) [6]. Matrix-assisted laser desorption/ionization time of flight (MALDI-TOF) mass spectrometry coupled with a DNA chip presents a new strategy for DNA analysis; it can analyze DNA extremely quick [12]. The oligonucleotide chip in reference [13] is very promising because the chip has a structure to control the hybridization by an electrode addressing each element of the chip. The DNA strands in a sample solution can quickly approach the probes immobilized on the chip surface. These DNA chip technologies, however, are mainly used in devices for analyzing a large number of DNA fragments, not for separating and preparing DNA fragments for further applications. A serious problem to be overcome in DNA separation applications is how to individually recover the DNA into aqueous solution from each small area on the microchip surface where DNA fragments are trapped.

Consequently, we developed a DNA preparation method that uses a photothermal approach to recover specific DNA fragments trapped on a chip surface. We found that the recovered DNA can be amplified by PCR and be subsequently characterized by further analysis. It is concluded that the developed method has a high potential for characterizing expressed genes and analyzing the differences between genes by using DNA chip.

## 2. Principle

The DNA preparation method is based on the fact that the stability of double-stranded DNA is highly dependent on temperature. As most double-stranded DNA fragments are denatured at 90–95°C, DNA hybridized with DNA

probes fixed in place on the chip surface can be released by thermal denaturation. The temperature of the chip surface is locally elevated by irradiating a small metal-coated area with an infrared (IR) laser beam as schematically shown in Fig. 1 [14].

The method consists of five processes: (1) hybridizing reaction of sample DNA fragments with probe DNA fixed on the chip surface; (2) washing the chip surface to remove non-specific DNA species; (3) heating a small metal-coated area on the chip by IR laser irradiation to extract specific DNA from the chip surface; (4) collecting the released DNA; and (5) repeating of steps (3) and (4) in order to recover multiple DNA fragments fixed on the chip. This method of photothermal denaturation using an IR laser and a DNA chip rapidly extracts DNA fragments from the chip surface because it does not require any cloning procedure or electrophoretic separation.

## 3. Experimental

### 3.1. DNA samples preparation

The DNA samples were prepared by the method previously reported [15] as disclosed below. A half picomole of amplified human genome fragments (8.7 kb, supplied by the Human Genome Center, Institute of Medical Science, University of Tokyo, Japan) was digested with 40 units of *Hsp92II* (Promega, WI, USA). The restriction fragments (400 fmol) were treated with alkaline phosphatase and ligated by 1400 units of T4 DNA ligase (Takara) with 80 pmol of adaptor (5'-pACTGGCCGTCGTTT-3') supported by 32 pmol of 5'-AAACGACGGCCAGTCATGp-3'. The phosphate residues were introduced into the 5'- and 3'-ends in order to prevent oligomer–oligomer ligation. The products ligated with the adaptor were purified with QIAquick

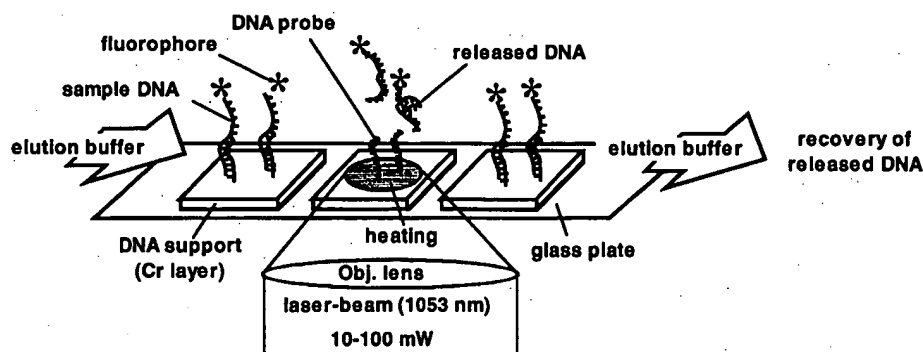

Fig. 1. Schematic illustration of DNA release from a DNA chip by using photothermal denaturation. The DNA hybridized with probe DNA fixed on a solid support can be released by a laser beam (1053 nm, 10–100 mW).

Spin Column (Qiagen, Hilden Germany) to eliminate free oligomers.

By using *Taq* DNA polymerase (0.625 units, Amersham Pharmacia Biotech, Amersham, UK) on a 50- $\mu$ l scale, the fragments ligated with adaptor (50 amol) were selectively amplified by PCR with primer pairs (10 pmol). The primer pairs (from Sawady Technology, Tokyo, Japan) were 5'-(sulforhodamine-101)-AACGACGGCCAGT-CACGNN-3' and 5'-NH<sub>2</sub>-AACGACGGCCAGTCACGN-N-3'. Here, N is any one of the four deoxynucleotides for discriminating a complementary DNA fragment by PCR [15]. The thermal cycling reaction was carried out 35 times at 94°C (30 s), 62°C (30 s) and 72°C (60 s). The six products of this amplification were checked by electrophoresis using a 2% agarose gel followed by staining with 0.5  $\mu$ g/ml ethidium bromide. They were analyzed by a FM-Bio 100 fluorescence image analyzer (Hitachi Software Engineering, Tokyo, Japan). The PCR product lengths were 779 bp (a pair of primers with discrimination sequences NN: AA and TC), 619 bp (NN: CG and TG), 411 bp (NN: GT and TA), 270 bp (NN: CA and TT), 231 bp (NN: CC and TT) and 179 bp (NN: AA and GT).

### 3.2. Preparation of the DNA chip

DNA was immobilized on a glass chip (45  $\times$  25  $\times$  0.4 mm<sup>3</sup>) coated with 6-nm-thick chromium. The chip with the chromium surface was modified with 3-glycidoxypropyltrimethoxysilane to introduce the active residue and to fix double-stranded DNAs (PCR products) on the surface. The PCR products had an amino residue at a 5'-terminus of one strand and sulforhodamine-101 fluorophore at a 5'-terminus of the other strand, so that it was fixed on the chip surface through their amino residue. The chip was sonicated in 1 M KOH aqueous solution, washed with H<sub>2</sub>O, and with 50% ethanol to clear the surface. After this pretreatment, the chip was dried for 30 min at 110°C, then dipped in neat 3-glycidoxypropyltrimethoxysilane for 15 min at 25°C followed by treating the same reagent (2%) diluted with 50% ethanol aqueous solution for 30 min. The chip was washed with 50% ethanol and dried at 110°C for 30 min to obtain a glycidoxy-activated chip. A solution of the DNA (10  $\mu$ M) dissolved in 0.25 M carbonate buffer (pH 9.5) was dropped onto the glycidoxy-activated chip by a pin array coupled with Biomek 2000 Laboratory Automation Workstation (Beckman). Pipette was also used to make DNA chip; in that case, 0.2  $\mu$ l of PCR products was dropped on the glycidoxy-activated chip. The chips are incubated at 50°C for 10 min in moisture atmosphere then kept at room temperature for 15 min. The remained active residues were blocked with Lys (0.1 M) dissolved in 0.25 M carbonate buffer (pH 9.5). The prepared DNA chips were stored in 20 mM of Tris-HCl (pH 7.5) containing 2 mM ethylenediaminetetraacetic acid (EDTA). The fixed DNA was easily detected by fluorescence imaging under a

confocal scanning microscope (LSM-200, Olympus, Tokyo, Japan).

### 3.3. Recovery of DNA by photothermal denaturation

The DNA chip was overlaid with 25  $\mu$ l of 20 mM Tris-HCl (pH 7.4) containing 2 mM EDTA. The laser (1053 nm, 10–100 mW on the surface of the DNA chip) was focused on the surface of the chip and about 20  $\mu$ l drop of solution from the laser-irradiated area was collected in a vessel. A part of recovered DNA (3  $\mu$ l) was amplified by PCR to check the DNA. The PCR was carried out using a primer (GTAAAACGACGGCCAGT). The amplified products were analyzed by electrophoresis using 2% agarose gel followed by staining with 0.5  $\mu$ g/ml ethidium bromide. The electropherograms were visualized by a fluorescence image analyzer (FM-Bio 100, Hitachi Software Engineering, Tokyo, Japan).

## 4. Results and discussion

We made a DNA-arrayed chip as shown in Fig. 2. Each of the six different PCR products was immobilized along separate rows of a 6  $\times$  6 grid. The photo shows a part of the DNA chip. The fluorescence from one spot clearly disappeared through IR laser irradiation, whereas the fluorescence from the untreated spots could be detected. This result indicates that the DNA from a small area was specifically released.

We then experimentally clarified the characteristics on how DNAs were released from the chip. As shown in the fluorescence image of Fig. 3, the fluorophore-labeled DNA (619 bp was immobilized at the fluorescent area on the chip) was removed from the irradiated region and the neighboring area. Bubbles were sometimes observed in the irradiated area, indicating that the solution temperature in the focused region could rise above the boiling point of water. The high temperature enabled the release of a DNA strand hybridized on its complementary strand fixed on the chip surface. It was possible to release the hybridized DNA from a 43- $\mu$ m-wide denaturation area by 50 mW. However, the chip surface was partially damaged by the IR irradiation at this condition. The chromium came off the glass plate (the darkest area at the center on line a–a' in Fig. 3), which could be easily observed by a phase-contrast microscope. Therefore, we optimized the laser power to release and recover the hybridized DNA from the chip surface. The fluorescence intensity at the small area of the laser-irradiated surface was measured in order to estimate the relative amount of denatured DNA. The hybridized DNA was released by the laser power ranging from 10 to 100 mW, as shown in Fig. 4 line A. More than 80% of the

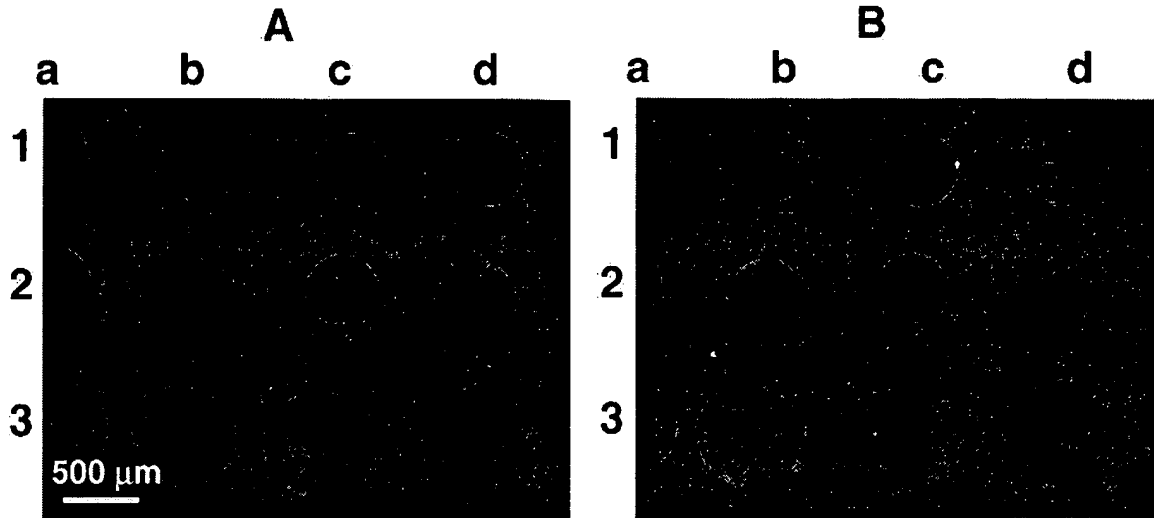

Fig. 2. Parts of fluorescence photographs of a DNA chip. The DNAs of 411, 270, and 231 bp were arrayed at lines 1–3 of each of column from a to d. Photograph A is the DNA chip before IR irradiation and photograph B is the same chip after IR irradiation at 10 mW. The IR laser-irradiated area was 1d.

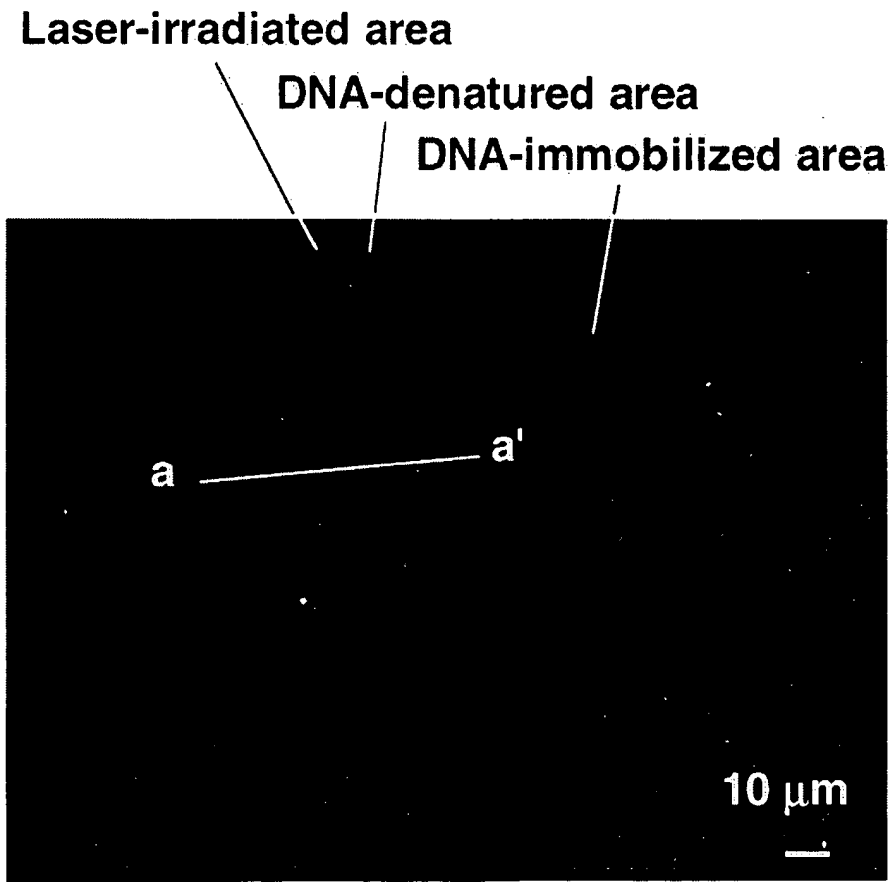

Fig. 3. Laser denaturation of a hybrid complex of sample DNA and probe DNA on chromium solid support (fluorescence image after laser irradiation). The fluorophore-labeled sample DNA disappeared from the small area on the solid support after laser irradiation. Intensity profiles at the a–a' line under various laser powers are depicted in Fig. 4.

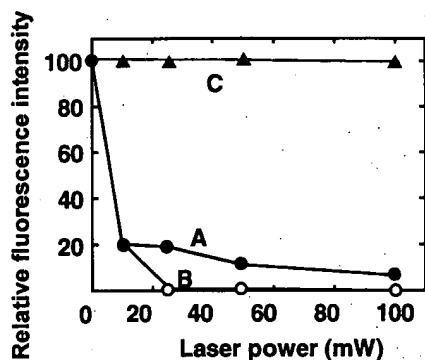

Fig. 4. Relative amounts of denatured DNA at different laser powers. The fluorescence intensity in the DNA-releasing area was measured from a fluorescence image as a relative amount of denatured DNA. The closed circles ● (line A) and open circles ○ (line B) show the fluorescence intensity in the DNA-denatured area and the chip-damaged area, respectively. The chip-damaged area, which was identified by phase-contrast microscopy, is the darkest area and the DNA-denatured area is the neighboring darkest area in Fig. 3. The same chip was treated with a fluorophore-labeled oligomer in order to rehybridize with the probe DNA on the chip surface, and the relative fluorescence intensity (▲, line C) was measured. The chip surface was not damaged at a laser power of 10 mW.

DNA was denatured and released from the chip surface by laser irradiation. It was possible to release the hybridized DNA by 10 mW light without damaging the chromium surface. However, the chip surface was partially damaged by the IR laser irradiation at a power of 25 mW or higher (line B). To prove that the DNA probe (or released DNA) was not damaged in the neighboring area of chromium-damaged area, we dropped a solution of fluorophore-labeled single-stranded DNA (60 base length) onto the surface. As shown by line C in Fig. 4, the previously denatured area was completely rehybridized with the fluorophore-labeled single-stranded oligomer DNA (60 base length), which hybridizes with a sequence near the 3' end

of the immobilized DNA strand. This shows that the DNA probe immobilized on the chip surface was not damaged after IR laser irradiation, because the 60 base length DNA could only hybridize to an intact DNA immobilized on the chip surface.

The recovered DNAs released from five different spots on one chip surface by a 10-mW laser were amplified by PCR. As shown in Fig. 5, one main product was detected in every electrophoresis of recovered DNA (lanes 9–13). The lengths of the products recovered from the DNA chip were about 800, 600, 420, 270, and 230 bp, respectively. They were the same as the intact immobilized DNA (lanes 2–6). Thus, the electropherograms show that the recovered DNA having different numbers of base pairs can be used as a template of PCR amplification. If the released DNA were damaged by the IR laser, the amplified products would not be obtained.

Some extra bands appeared in the electropherograms of recovered DNA. The immobilized DNA were prepared by the PCR using 5'-AACGACGGCCAGTCACGNN-3' from a mixture of DNA fragments depicted in lane 7. All the fragments have the common sequence of AACGACGGCCAGT at both their 3'-termini. The PCR products in lanes 9–13 were amplified by using a common sequence primer. Since both the immobilized DNA and contaminants can be amplified with a common primer, there were some extra products in the electropherograms.

## 5. Conclusions

We have experimentally studied the characteristics of photothermal release of DNAs from a DNA chip. The DNA chip technology will allow separation of many different DNA fragments in one step. The procedure developed in the present study for releasing specific DNA fragments from the DNA chip has great potential in the

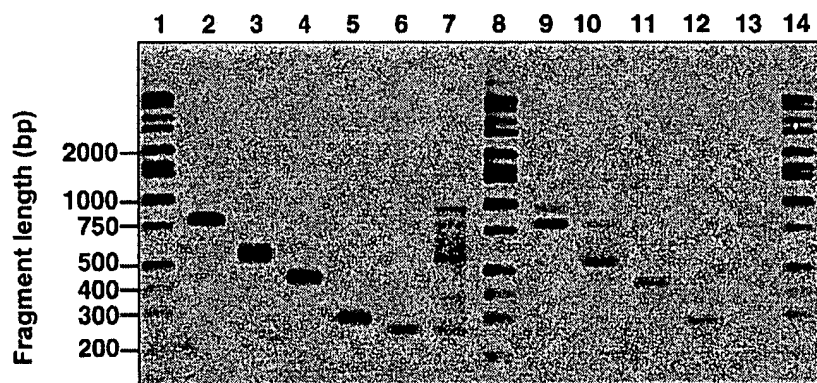

Fig. 5. Electropherograms of PCR products. The templates are DNA fragments recovered from the IR laser-irradiated chip (lanes 9–13), intact immobilized PCR products prepared from a mixture of DNA fragments (lanes 2–6), the mixture of DNA fragments (lane 7), and a marker (lanes 1, 8, and 14).

field of DNA preparation and purification. In general, hybridization reactions occur between not only complementary strands but also strands having similar sequences. The hybridization reaction is carried out at uni-condition because each probe element on the chip is too small to independently control the hybridization condition, e.g., annealing temperature and salt concentration. This is a drawback of the DNA chip because non-specific hybridization of similar DNA sequences with DNA probes on the chip frequently occurs. However, we consider that it will be a merit to analyze rapidly many kinds of DNA fragments because the chip elements can group the fragments according to the similarity of their sequences. Our photo-thermal method makes it possible to further analyze once the trapped DNA fragments on the chip elements. The DNA chip, coupled with photothermal denaturation, will work at searching DNA fragments of similar sequences (e.g., making a wholesale detection of DNA super family) to the best of its ability.

Molecular biology is rapidly approaching the stage of functional genomics. The screening of total gene expression profiles and the analysis of genome differentiation of species have become major research fields. A preparation method that enables separation of DNAs based on differences in expressed messages or in genomics will become more important. Our photothermal releasing procedure coupled with the DNA chip will have great potential in this field.

### Acknowledgements

The authors thank Professor Sakaki for kindly supplying the human genome DNA. This research was partially supported by Grants-in-Aid for Scientific Research, for Scientific Research on Priority Areas and for the High-Tech Research Center Project from the Ministry of Education, Science, Sports and Culture of Japan.

### References

- [1] P.L. Deininger, Random subcloning of sonicated DNA: application to shotgun DNA sequence analysis, *Anal. Biochem.* 129 (1983) 216–223.
- [2] D.J. Lockhart, H. Dong, M.C. Byrne, M.T. Follettie, M.V. Gallo, M.S. Chee, M. Mittmann, C. Wang, M. Kobayashi, H. Horton, E.L. Brown, Expression monitoring by hybridization to high-density oligonucleotide arrays, *Nat. Biotechnol.* 14 (1996) 1675–1680.
- [3] S.P.A. Fodor, J.L. Read, M.C. Pirrung, L. Stryer, A.T. Lu, D. Solas, Light-directed, spatially addressable parallel chemical synthesis, *Science* 251 (1991) 767–773.
- [4] A.C. Peasc, D. Solas, E.J. Sullivan, M.T. Cronin, C.P. Holmes, S.P. Fodor, Light-generated oligonucleotide arrays for rapid DNA sequence analysis, *Proc. Natl. Acad. Sci. U.S.A.* 91 (1994) 5022–5026.
- [5] M. Schena, D. Shalon, R.W. Davis, P.O. Brown, Quantitative monitoring of gene expression patterns with a complementary DNA microarray, *Science* 270 (1995) 467–470.
- [6] D.G. Wang, J.-B. Fan, C.-J. Siao, A. Berno, P. Young, R. Sapolsky, G. Ghandour, N. Perkins, E. Winchester, J. Spencer, L. Kruglyak, L. Stein, L. Hsie, T. Topaloglou, E. Hubbell, E. Robinson, M. Mittmann, M.S. Morris, N. Shen, D. Kilburn, J. Rioux, C. Nusbaum, S. Rozen, T.J. Hudson, R. Lipshutz, M. Chee, E.S. Lander, Large-scale identification, mapping, and genotyping of single-nucleotide polymorphisms in the human genome, *Science* 280 (1998) 1077–1082.
- [7] J.B. Lamture, K.L. Beattie, B.E. Burke, M.D. Eggers, D.J. Ehrlich, R. Fowler, M.A. Hollis, B.B. Kosicli, R.K. Reich, S.R. Smith et al., Direct detection of nucleic acid hybridization on the surface of a charge-coupled device, *Nucleic Acids Res.* 22 (1994) 2121–2125.
- [8] M. Schena, D. Shalon, H. Heller, A. Chai, P.O. Brown, R.W. Davis, Parallel human genome analysis: microarray-based expression monitoring of 1000 genes, *Proc. Natl. Acad. Sci. U.S.A.* 93 (1996) 10614–10619.
- [9] K.R. Khrapko, Yu.P. Lysov, A.A. Khorlyn, V.V. Shick, V.L. Florentiev, A.D. Mirzabekov, An oligonucleotide hybridization approach to DNA sequencing, *FEBS Lett.* 256 (1989) 118–122.
- [10] G. Yershov, V. Barsky, A. Belgovskiy, E. Kirillov, E. Kreindlin, I. Ivanov, S. Parinov, D. Guschin, A. Drobishev, S. Dubiley, A. Mirzabekov, DNA analysis and diagnostics on oligonucleotide microchips, *Proc. Natl. Acad. Sci. U.S.A.* 93 (1996) 4913–4918.
- [11] M.J. Marton, J.L. DeRisi, H.A. Bennett, V.R. Iyer, M.R. Meyer, C.J. Roberts, R. Stoughton, J. Burchard, D. Slade, H. Dai, D.E. Bassett Jr., L.H. Hartwell, P.O. Brown, S.H. Friend, Drug target validation and identification of secondary drug target effects using DNA microarrays, *Nat. Med.* 4 (1998) 1293–1301.
- [12] M.J. O'Donnell, K. Tang, H. Koster, C.L. Smith, C.R. Cantor, High-density, covalent attachment of DNA to silicon wafers for analysis by MALDI-TOF mass spectrometry, *Anal. Chem.* 69 (1997) 2438–2443.
- [13] J. Cheng, E.L. Sheldon, L. Wu, A. Uribe, L.O. Gernue, J. Carrino, M.J. Heller, J.P. O'Connell, Preparation and hybridization analysis of DNA/RNA from *E. coli* on microfabricated bioelectronic chips, *Nat. Biotechnol.* 16 (1998) 541–546.
- [14] H. Kato, T. Nishizaka, T. Iga, K. Kinoshita Jr., S. Ishiwata, Imaging of thermal activation of actomyosin motors, *Proc. Natl. Acad. Sci. U.S.A.* 96 (1999) 9602–9606.
- [15] K. Okano, C. Uematsu, H. Matsunaga, H. Kambara, Characteristics of selective polymerase chain reaction (PCR) using two-base anchored primers and improvement of its specificity, *Electrophoresis* 19 (1998) 3071–3078.

### Biographies

*K. Okano* is working for Central Research Laboratory, Hitachi as a Senior Research Scientist in research on methodology for analyzing DNA, i.e., DNA fingerprinting, sequencing, and DNA assay. He investigated characteristics of PCR and developed a method to eliminate the false-positive amplification reaction. Furthermore, he demonstrated that any unknown sequenced DNA fragment digested with a restriction enzyme can be grouped in 136 windows by using improved PCR with a library as small as 16 primers.

*K. Yasuda* is an Associate Professor at the University of Tokyo. He has been studying several fields such as the muscle contractile mechanism, basic and applications of acoustic radiation force, and biochip technologies. In the study, he proposed the non-contact handling method of biomaterials in the microchamber for the high-throughput, contamination-free analysis using acoustic radiation force.



*S. Ishiwata* is a Professor at Waseda University. He has been studying the mechanism of protein motors on a single molecular level, the molecular synchronization observed in motor assemblies, and the mechanism of formation of the organized structures in muscle. His groups used optical tweezers to successfully measure the mechanical properties of a single actomyosin complex. They demonstrated auto-oscillatory properties of actomyosin motors and reconstitution of thin actin filaments in the contractile apparatus of cardiac muscle.



**IN THE UNITED STATES PATENT AND TRADEMARK OFFICE**

Applicant(s):	Stavrianopoulos, <i>et al.</i>	)	
Serial No.:	08/486,070	)	Group Art Unit: 1631
Filed:	June 7, 1995	)	Ex'r: Ardin H. Marschel, Ph.D.
For:	<b>ARRAYS AND SYSTEMS COMPRISING ARRAYS FOR GENETIC ANALYSES AND OTHER APPLICATIONS</b>	)	
	(As Previously Amended)	)	

South Portland, Maine

Assistant Commissioner for Patents  
Washington, D.C. 20231

**DECLARATION OF DR. ALEXANDER A. WALDROP, III**

I, Alexander A. Waldrop, III, hereby declare as follows:

1. Since 2000, I have been the sole proprietor of my own start-up company having a principal place of business at the Center for Environmental Enterprise (CEE), South Portland, Maine.<sup>1</sup> My present research work focuses on acridine compounds, such as 9-acridinecarbonylimidazole (AcriGlow™ 301), for use in chemiluminescent assays for medical and environmental diagnostics. My professional experience includes research at several organizations, including Maine Medical Center Research Institute, South Portland, Maine (1994 to 2000), IDEXX Laboratories, Inc., Westbrook, Maine (1992-1993), and Gen-Probe, Inc., San

<sup>1</sup> CEE is a private, non-profit organization funded by the State of Maine as a business incubator. Located on the campus of Southern Maine Community College, CEE helps new and young firms like my own to commercialize technologies in the environmental field.

Enz-7(P)(C3)

Diego, California (1985-1992) as described in my *curriculum vitae* (cv).<sup>2</sup> Over the past several years I served as a consultant for companies such as Brims Ness, Capricorn Products, Inc., Maine Standards, and Enzo Biochem, Inc.

2. My education and research experience are listed in my cv. I received my bachelor of science degree (B.S.) from the University of Virginia in 1970, graduating with high distinction (*magna cum laude*). In 1977 I received my doctoral degree (Ph.D.) in biophysics from The Johns Hopkins University, Baltimore, Maryland. While at Johns Hopkins, I trained in the Department of Biophysics as a pre-doctoral fellow in the laboratory of Dr. Michael Beer from 1970-1977. I developed multiple heavy atom stains for electron microscopy of nucleic acids. My doctoral dissertation was titled "Chemical Studies of *bis*(Pyridine)osmate(VI) Esters and the Mercury Enhancement of Osmium Labelling of Polynucleotides" [Dissertation Abstracts International 38 (11-B):5354+ (194 pp.) (1978)]. As a postdoctoral fellow, I worked in the laboratory of Dr. David C. Ward at Yale University, New Haven, Connecticut from 1977-1980. While at Yale I used reactions with heavy metal intermediates to synthesize detectable non-radioactively modified nucleotides. I contributed to the discovery that these modified nucleotides could be incorporated *in vitro* into nucleic acids for use as non-radioactive nucleic acid probes. This discovery led directly to the development of several non-radioactively modified nucleotides and nucleotide analogs which are used for *in situ* gene and nucleic acid detection. These modified nucleotides and nucleotide analogs and their use in detection processes are described in several U.S. patents (Nos. 4,711,955; 5,328,824; 5,449,767; and 5,476,928). I am one

---

<sup>2</sup> Copy attached as Exhibit 1.

of three inventors listed on these patents.<sup>3</sup> These modified nucleotides and nucleotide analogs include biotinylated nucleotides and other labeled oligonucleotides which have been sold commercially for years.

3. After my postdoctoral work, I was Assistant Professor of Chemistry at the University of Virginia, Charlottesville, Virginia, from 1980-1982. While working in the UVA Department of Chemistry, I taught undergraduate biophysical chemistry. I also prepared nucleotide derivatives of tubercidin and characterized allylamine derivatives. From 1982-1985, I was Research Associate in the Department of Microbiology at UVA where I worked on several projects including the development of a new DNA sequencing method and a gel filtration method for nucleotide purification and desalting, and the synthesis of a series of 5'-thymidine triphosphate derivatives and a dUTP analog containing an ethylenediamine-tetraacetic acid (EDTA) group.

4. I am the author of five scientific publications and I am also an inventor on seven U.S. patents, including the four patents referenced in paragraph 2 above.

5. Enzo Life Sciences, Inc. has asked me as its scientific consultant to review significant portions of the most recent prosecution history of United States Patent Application Serial No. 08/486,070, filed on June 7, 1995 ("the '070 application) in the name of Jannis G. Stavrianopoulos, *et al.* The title of the '070 application is "Arrays and Systems Comprising Arrays for

---

<sup>3</sup> All four of these U.S. patents name David C. Ward, Pennina R. Langer and Alexander A. Waldrop, III, as co-inventors. U.S. Patent No. 4,711,955 is titled "Modified Nucleotides and Methods of Preparing and Using Same" and it issued on December 8, 1987. U.S. Patent No. 5,328,824 is titled "Methods of Using Labeled Nucleotides" and it issued on July 12, 1994. U.S. Patent No. 5,449,767 is titled "Modified Polynucleotides and Methods of Preparing Same," having issued on September 12, 1995. The fourth, U.S. Patent No. 5,476,928, is titled "Modified Nucleotides and Polynucleotides and Complexes Formed Therefrom," and it issued on December 19, 1995.

Genetic Analyses and Other Applications." Included for my review were the following documents and materials:

- the original specification [U.S. Patent Application Serial No. 06/732,374, filed on May 9, 1985];
- two Office Actions dated April 7, 2004 and July 2, 2003; and
- Four Interview Summaries dated April 1, 2004, May 20, 2004, September 5, 2002 and December 17, 2002.

I have also reviewed several Responses filed in the '070 application, including:

- Applicants' October 31, 2003 Amendment Under 37 C.F.R. §1.115;
- their May 8, 2003 Supplemental Amendment;
- their December 31, 2002 Communication For Submitting Eight Charts In Support Of Applicants' Invention Claimed In U.S. Patent Application Serial No. 08/486,070;
- their December 6, 2002 Communication (To Submit Chapters From A DNA Microarray Protocols & Review Book);
- their December 3, 2002 Amendment Under 37 C.F.R. §1.115; and
- the September 4, 2002 Communication To Transmit The Declaration Of Dr. James G. Wetmur.

I am being compensated for my review and for making this Declaration.

6. In conjunction with my review of the April 7, 2004 Office Action, I have read both former claims (2163-3143) presented in Applicants' October 31, 2003 Amendment Under 37 C.F.R. §1.115, and new claims (3144-3286)<sup>4</sup> being presently submitted to the U.S. Patent Office. In the former claims, I have read and I understand that the subject matter of claims 2715-3029 is directed to an

---

<sup>4</sup> Copy attached as Exhibit 2.

array of various nucleic acid(s) or sequences fixed or immobilized to a non-porous solid support. Three of the former array claims, 2715, 2825 and 2933, are independent. The first, claim 2715, recites "[a]n array of various single-stranded nucleic acids or sequences thereof in hybridizable form, said array comprising a non-porous solid support having reactive sites or binding site(s) thereon, wherein said various single-stranded nucleic acids or sequences thereof are fixed or immobilized to said reactive site(s) or binding site(s)." The second, claim 2825, recites "[a]n array of various double-stranded nucleic acids, said array comprising a non-porous solid support having reactive site(s) or binding site(s) thereon, wherein said various double-stranded nucleic acids are fixed or immobilized to said reactive site(s) or binding site(s), wherein at least one nucleic acid strand of said various double-stranded nucleic acids comprises at least one non-radioactive chemical label which comprises a non-radioactive signaling moiety which is quantifiable or detectable." The third, claim 2933, recites "[a]n array of various nucleic acid strands or sequences thereof, said array comprising a non-porous solid support having wells or depressions, and said various nucleic acid strands or sequences being fixed or immobilized in hybridizable form thereto."

7. In the new claims being submitted to the U.S. Patent Office, I understand that claims 3198-3221 and 3222-3245 are also directed to an array. Four of the new array claims are independent. The first, claim 3198, recites "[a]n array of various single-stranded nucleic acids directly or indirectly fixed or immobilized in hybridizable form to a non-porous solid support, wherein when said nucleic acids are indirectly fixed or immobilized to said non-porous solid support, said indirect fixation or immobilization is not to a cell fixed *in situ* to said non-porous solid support." The second, claim 3199, recites "[a]n array of various double-stranded nucleic acids directly or indirectly fixed or immobilized to a non-porous solid support, wherein at least one nucleic acid strand of said various double-stranded

nucleic acids comprises at least one non-radioactive chemical label which is quantifiable or detectable, and wherein when said nucleic acids are indirectly fixed or immobilized to said non-porous solid support, said indirect fixation or immobilization is not to a cell fixed *in situ* to said non-porous solid support." The third, claim 3222, recites "[a]n array of various single-stranded nucleic acids directly or indirectly fixed or immobilized in hybridizable form to a non-porous solid support having wells or depressions, wherein when said nucleic acids are indirectly fixed or immobilized to said wells or depressions of said non-porous solid support, said indirect fixation or immobilization is not to a cell fixed *in situ* to said wells or depressions of said non-porous solid support." The fourth, claim 3223, recites "[a]n array of various double-stranded nucleic acids directly or indirectly fixed or immobilized to a non-porous solid support having wells or depressions, wherein at least one nucleic acid strand of said various double-stranded nucleic acids comprises at least one non-radioactive chemical label which is quantifiable or detectable, and wherein when said nucleic acids are indirectly fixed or immobilized to said wells or depressions of said non-porous solid support, said indirect fixation or immobilization is not to a cell fixed *in situ* to said wells or depressions of said non-porous solid support."

8. Prior to the '070 invention, two means for detecting nucleic acids based on hybridization were filter hybridization using porous membranes and/or filters, and *in situ* hybridization where the cells were fixed to non-porous substrates. A classic example of filter hybridization or colony hybridization is the work of Michael Grunstein and David S. Hogness ["Colony hybridization: A method for the isolation of cloned DNAs that contain a specific gene," Proc. Natl. Acad. Sci. (USA) 72:3961-3965 (1975)].<sup>5</sup> In carrying out hybridization on a nitrocellulose filter with

---

<sup>5</sup> Copy attached as Exhibit 3.

probes labeled with  $^{32}\text{P}$  or  $^3\text{H}$ , the authors screened for the presence of at least two different sequences, in particular, the 18S and 28S rRNA from *D. melanogaster*. The work of Grunstein and Hogness was adopted by other researchers, and in some cases, refined or expanded. For example, in 1979, J. G. Williams and M. M. Lloyd ["Changes in the Abundance of Polyadenylated RNA During Slime Mould Development Measured Using Cloned Molecular Hybridization Probes," J. Mol. Biol. 129:19-35],<sup>6</sup> adapted the procedure of Grunstein and Hogness to monitor differences in mRNA expression in slime mold using a library of cDNA clones and a collection of radioactively labeled probes made from poly(A) mRNA harvested at different times of development. The next year a similar procedure was reported by Mark B. Dworkin and Igor B. Dawid ["Use of a Cloned Library for the Study of Abundant Poly(A) + RNA during *Xenopus laevis* Development," Dev. Biol. 76:449-464 (1980)]<sup>7</sup> who used a panel of 860 clones with  $^{32}\text{P}$  labeled probes made from pools of poly(A) mRNA from various stages of development in *Xenopus*.

9. The non-porous solid support formatting of the '070 invention provided advantages and benefits over the filter hybridization technique. Some of the benefits and advantages include: (a) rigidity and stability obtained with glass and plastic materials allow more precision and easier use in spotting nucleic acids to specific loci on a surface;<sup>8</sup> (b) characteristics of a non-porous surface provide reliability and consistency in nucleic acid attachment and subsequent hybridization; (c) regularity in non-porous surface conformation provides more ease and superior speed in washing; (d) greater adaptability to automation; and (e) better quantifiable detection of nucleic acid hybridization by photometric techniques.

---

<sup>6</sup> Copy attached as Exhibit 4.

<sup>7</sup> Copy attached as Exhibit 5.

<sup>8</sup> Porous membranes and porous filter papers are particularly prone to tearing.



10. I have read the April 7, 2004 Office Action. I understand that the Patent Examiner rejected the former claims, including array claims (2715-3029), "as failing to comply with the written description requirement." I also understand that the Examiner alleges that "the claim(s) contains subject matter which was not described in the specification in such a way as to reasonably convey to one skilled in the relevant art that the inventor(s), at the time the application was filed, had possession of the claimed invention." Quoted below is a portion of the April 7, 2004 Office Action (page 3, last two lines, through page 4, first paragraph) that deals specifically with claims 2715, 2825 and 2933:

Consideration of array claim 2715 reveals that it is directed to a generic non-porous solid support with various single-stranded nucleic acids or sequences fixed or immobilized thereto. Reiterated consideration of the entirety of the instant disclosure reveals that the practice of "various denatured analytes" with a solid support is disclosed only on page 16, lines 9-14, as being present for example in an array of depressions or wells. A generic solid support is not disclosed as filed nor a non-porous generic support of this type with "various single-stranded nucleic acids or sequences" as now present in claim 2715 and others via dependence, such as claim 2825 and claims dependent therefrom. Review of instant claim 2933 directed to wells or depressions with said "various..." limitations reveals that the nucleic acid strands or sequences are either fixed or immobilized whereas in contrast said page 16 citation only cites fixation practice. Thus claims 2933 also contains NEW MATTER for this reason. This rejection is necessitated by amendment which set forth such "various..." limitations.

11. As set forth above and in my cv, I am a chemist with substantial experience and background in nucleic acid chemistry. My knowledge, background, training and experience in nucleic acid chemistry encompasses nucleic acid modifications, including labeling nucleic acids for use in hybridization and detection assays. I am familiar with several nucleic acid detection formats and with nucleic acid probe technology in general. My professional and academic career involves extensive

research exploring the modifications and labeling of nucleic acids for use as probes in hybridization and detection assays. One of my more recent areas of research is chemiluminescence and assays using chemiluminescent reagents to detect a wide variety of substances including nucleic acids and other biomolecules.

12. Based upon my training, background and experience, I believe that at the time the '070 application was filed in May 1985 (as a continuation-in-part of U.S. Patent Application Serial No. 06/461,469, filed January 21, 1983), the relevant art to the subject matter being claimed as arrays would have included many if not most of the following areas: modifications of nucleic acids, nucleic acid synthesis and labeling, surface chemical treatments, and nucleic acid hybridization, formatting and detection. I consider myself to possess the level of skill, knowledge, training and experience of at least a person skilled in the art to which the present array invention pertains.

13. I understand that a patent specification describes the subject matter of a claim, if the specification conveys, with reasonable clarity to a person skilled in the art, that the inventors were in possession of that subject matter recited in that claim. I also understand that to satisfy the written description requirement, the inventors do not have to utilize any particular form of disclosure to describe the subject matter of the claim under consideration. For instance, the description of the invention being claimed may be found in the working examples, in a more general description of the invention, or even in a combination of the examples and the general description.

14. As a person skilled in the art, it is my opinion and conclusion that the '070 specification reasonably conveys that Applicants were in possession of their

claimed array invention at the time their application was filed in May 1985.<sup>9</sup> I believe that the Examiner is wrong when he alleges in the April 7, 2004 Office Action that ". . . the practice of "various denatured analytes" with a solid support is disclosed only on page 16, lines 9-14, as being present for example in an array of depressions or wells."<sup>10</sup> In my opinion, neither the '070 specification generally nor the cited description on page 16, lines 9-14, limits Applicants' array invention and "various nucleic acids" to an array having depressions or wells. Indeed, after carefully reviewing the '070 specification, I conclude that Applicants' description of wells in the specification generally, and on page 16, lines 9-14 in particular, illustrates, through example, one of the different forms or embodiments of their array invention, including "various denatured analytes." My reasons in reaching this conclusion are given below.

15. Several portions of the '070 specification make it clear that the inventors referenced or used wells to illustrate the different forms of their invention in which nucleic acids are fixed or immobilized to non-porous solid supports.

A. The citation to the '070 specification (page 16, lines 9-14) made by the Examiner in the Office Action reads as follows:

**For example**, glass plates provided with an array of depressions or wells would have samples of the **various denatured analytes** deposited therein, the single-stranded analytes being fixed to the **surfaces of the wells**.  
[emphasis added]

It is clear to me as a person skilled in the art that the above references to an array and "various denatured analytes" are not limited to depressions or wells. Further it

---

<sup>9</sup> By implication, I am also asserting that the subject matter of former rejected array claims 2715-3029 were also in the possession of the inventors.

<sup>10</sup> Although the Examiner did choose to use the words "for example" in the Office Action (page 4, line 3), it is not apparent whether he attached appropriate significance to them.

is clear that the practice of "various denatured analytes" or "various nucleic acids" is not limited to an array with depressions or wells.

B. There are several reasons why the above-quoted statement, taken alone or taken with other portions in the '070 specification, does not limit the array invention to depressions or wells. First, the very statement itself begins with the introductory phrase, "For example." "For example" clearly conveys that "depressions or wells" are illustrative or exemplary of an array. Second, the above-quoted statement is located in Example 1 in the "examples" or "Detailed Description" section of the '070 specification. The preceding page (p. 15) in the '070 specification makes it clear:

**Other aspects and advantages of the present invention will be readily apparent upon consideration of the following detailed description of the preferred embodiments thereof.**

#### DETAILED DESCRIPTION

The following **examples** are **illustrative** of preferred embodiments of the method of the present invention. Specifically referred to therein are methods for fixing the analyte to a **non-porous solid support . . .**  
[emphasis added]

The statements quoted above clearly convey that other aspects and advantages beyond the examples that follow on pages 15-25 will be readily apparent. As a person skilled in the art, I read Example 1 and the cited page 16, lines 9-14, as being merely illustrative of one way (depressions or wells) in which nucleic acids can be fixed or immobilized to a non-porous solid support in the form of an array. Because the various surface treatments illustrated in the examples and used to fix or immobilize nucleic acids to non-porous solid supports are not dependent upon the shape or conformation of the support, it is my opinion that Example 1 does not limit Applicants' array practice to depressions or wells. Other aspects of the invention, including the use of other conventional apparatus employed in diagnostic

laboratories, such as a plate (for example, a flat Petri dish), a tube, a cuvette, a bead, and the like, are conveyed to me from reading Example 1 and the '070 specification.

C. Reference to wells is made in other parts of the '070 specification to illustrate fixation or immobilization of nucleic acids to specific materials, such as a glass or plastic surface. Examples 5, 6 and 7 provide further description in this regard.

(i) Example 5 (last two lines on page 20, continuing through first two lines on page 21) provides:

In tests involving the **fixing of DNA to a plastic surface**, biotinylated DNA (bDNA) was denatured and aliquoted into Dynatech, Immulon II™ removeable **wells**. . . [emphasis added]

(ii) Example 6 (last paragraph on page 22, continuing through line 5 on page 23) provides:

An improved capability for **fixing or immobilization of DNA to non-porous solid supports, such as glass and plastic**, is also provided by treatment with a coating of an epoxy resin. For example, treatment of glass or polystyrene **surfaces** with commercially available epoxy glues, such as a solution of epoxy glue in ethanol [1 percent w/v] serves this purpose. These epoxy solutions are applied to the **surfaces or wells**, . . . [emphasis added]

(iii) The first paragraph in Example 7 (page 23) also provides:

Yet another **example** of the method of the present invention, including fixing the polynucleotide analyte sequence directly to a **non-porous solid support, such as a conventional microtiter well**, may be performed according to the procedures outlined below.

[emphasis added]

16. To a person skilled in the art, Applicants provide further description as to why the '070 specification does not limit the practice of "various denatured

analytes" to an array of depressions or wells. First, I believe that the term "various" used in the array claims means nucleic acids, whether analytes or probes, which have different sequences from one another. It is my opinion that the '070 specification supports the claim language of "various nucleic acids" because there are many descriptions of various nucleic acids in the context of different non-porous solid supports and different treatments of non-porous solid supports that are *not* limited to wells or depressions. Instances of these descriptions are given in the paragraphs that follow.

17. In the very first two pages of the '070 specification, the term "analyte" is defined as follows:

**Analyte** -- A **substance or substances**, either alone or in admixtures, whose presence is to be detected and, if desired, quantitated. The analyte may be a DNA or RNA molecule of small or high molecular weight, a molecular complex including those molecules, or a **biological system containing nucleic acids**, such as a virus, a cell, or a group of cells. **Among the common analytes are nucleic acids (DNA and RNA) or segments thereof, oligonucleotides**, either single- or double-stranded, viruses, bacteria, cells in culture, and the like. **Bacteria**, either whole or fragments thereof, including both gram positive and gram negative bacteria, fungi, algae, and other microorganisms are also analytes, as well as **animal (e.g., mammalian) and plant cells and tissues**. [Emphasis added]

18. In the definition quoted above, an analyte is defined as "a substance or substances, either alone or in admixtures, whose presence is to be detected and, if desired, quantitated." This statement conveys to me that an analyte can take the form of substances whose presence is being detected or quantified.

19. As part of the above definition of "analyte," common analytes include "nucleic acids (DNA and RNA) or segments thereof." In the context of a biological system, e.g., a cell, this conveys to me as a person skilled in the art that a number

of different nucleic acid forms are included, including chromosomal DNA, plasmid DNA, messenger RNA, transfer RNA and ribosomal RNA. Thus, there would be thousands of unique RNA fragments derived from various messenger RNAs. Even in the simplest biological system, such as a bacterial cell which contains a single chromosome, it is practically impossible to isolate the chromosome as a single molecule. Consequently, the chromosomal DNA derived from a bacterial cell will consist of different fragments, each fragment having its own unique sequence. In a more complicated biological system, such as a mammalian cell, nucleic acid sequences, including gene sequences, exist on separate chromosomes. There, the chromosomal DNA derived from a mammalian cell will again also consist of different fragments, with each fragment having its own unique sequence.

20. The above-quoted definition of an analyte also refers to a "biological system containing nucleic acids, such as . . . a cell." This conveys to me that the analyte can contain any or all of the nucleic acids that are found within a cell. Such a biological system, e.g., a cell, would comprise large numbers of different nucleic acid sequences.

21. In the '070 definition of analyte, cells are mentioned as examples of biological systems including bacteria, animal (e.g., mammalian) and plant cells. Again, all of these cells contain a large number of different nucleic acid sequences.

22. In the '070 "Summary Of The Invention" (page 9, lines 16-30), it is disclosed:

The present invention provides a solution for the disadvantages of presently available methods of detecting **analytes** by a novel combination of hybridization and immunological techniques. In accordance with the practice of the present invention, chemically labelled polynucleotide or oligonucleotide **probes are employed to**

**detect analytes** by having the capacity to generate a reliable, easily quantifiable soluble signal.

**Analytes to be detected** by the detection processes of this invention may be present in any **biological or non-biological sample**, such as clinical samples, for example, blood, urine, feces, saliva, pus, semen, serum, other tissue samples, fermentation broths, culture media, and the like. . . [emphasis added]

In the '070 specification (page 10, lines 6-9), it is also disclosed:

In accordance with the practices of this invention, **analytes in a biological sample** are preferably denatured into single-stranded form, and then directly fixed to a suitable solid support. [emphasis added]

Most biological samples will contain a collection of different nucleic acid fragments. That "analytes in a biological sample . . . [are] . . . fixed to a suitable solid support" reasonably conveys to me as a person skilled in the art that different nucleic acid sequences are being described, and that such different sequences are fixed or immobilized to a suitable solid support. I find this to be particularly so because there is no mention of purification or isolation with respect to the analytes in the biological sample.

23. The original Abstract Of The Disclosure, found on the last page of the '070 specification, provides the following:

**Polynucleotide sequences in a sample of biological or nonbiological material** are detected by a method involving fixing of the sequences on a solid support and forming an entity between the fixed sequences and chemically-labeled polynucleotide or oligonucleotide probes having a sequence complementary to the fixed sequence for determining the identification and/or presence of the target polynucleotide sequences. The chemical label covalently or non-covalently attached to the probe comprises a signalling moiety capable of generating a soluble signal detectable by spectrophotometric assay techniques. [emphasis added]



In reading the above original Abstract, it is my opinion that the *polynucleotide sequences which are fixed to the solid support* comprise different nucleic acid sequences, particularly because such polynucleotide sequences are contained in a sample of biological or nonbiological material. I note that the above-quoted Abstract does not describe or refer to the sample as having been purified or that the polynucleotide sequences have been purified or isolated. I also note that the Abstract refers to a method step of forming an entity between the *fixed sequences and chemically-labeled polynucleotide or oligonucleotide probes* having a sequence complementary to the fixed sequence for determining the identification and/or presence of the target polynucleotide sequences. As a person skilled in the art, it is my opinion that the foregoing statement and the use of multiple chemically-labeled polynucleotide or oligonucleotide probes for determining identification and/or presence of target polynucleotide sequences reasonably conveys that various different target polynucleotide sequences are being described. Thus, the original Abstract supports Applicants' claimed invention wherein an array of various different nucleic acids are fixed or immobilized to a non-porous solid support.

24. In summary, and for the reasons given above, I conclude as a person skilled in the art that that the '070 specification reasonably conveys that the Applicants and inventors were in possession of the subject matter of new array claims 3198-3245 currently being submitted to the Patent Office.

I hereby declare that all statements made herein of my own knowledge are true and that all statements made on information and belief are believed to be true; and further that these statements are made with the knowledge that willful false statements and the like so made are punishable by fine or imprisonment, or both, under Section 1001 of Title 18 of the United States Code, and that any such willful

false statements may jeopardize the validity of the application or any patent issued thereon.

June 29, 2004  
Date

Dr. Alexander A. Waldrop III  
Dr. Alexander A. Waldrop, III

\* \* \* \* \*

**FinalDecl.6.28.04 (8 PM)**

# Curriculum Vitae of Alexander A. Waldrop, III

## ADDRESS

260 Westbrook Street #10  
South Portland, Maine 04106-3350  
(207) 773-6450 (207) 767-4800  
(207) 767-4306 fax  
[awaldrop@maine.rr.com](mailto:awaldrop@maine.rr.com) or [alexw3@hotmail.com](mailto:alexw3@hotmail.com)

## EDUCATION

Ph.D. (Biophysics) 1977, Johns Hopkins University, Baltimore, Maryland,  
Thesis Advisor: Dr. Michael Beer,  
Thesis Title: "Chemical Studies "Chemical Studies of  
*bis*(Pyridine)osmate(VI) Esters and the Mercury  
Enhancement of Osmium Labelling of Polynucleotides"  
Dissertation Abstracts International 38 (11-B):5354+  
(194 pp.) (1978);  
B.S. (Chemistry) 1970, Magna cum Laude, University of Virginia.

## HONORS

Echols Scholar, Phi Eta Sigma, Hugh Miller Spencer Scholarship in  
Chemistry, 1970.

## PROFESSIONAL MEMBERSHIPS

Alpha Chi Sigma, Sigma Xi, AAAS, AACC, American Chemical Society.

## EXPERIENCE

Founder and Principal Scientist, Started Company at Center for  
Environmental Enterprise (CEE), 2000 to present. Further characterized  
9-Acridinecarbonylimidazole (AcriGlow 301) and its reaction with  
peroxide in various buffers and solvents. Examined ways of removing  
peroxide impurities from solvents, detergent and polymer solutions.  
Tested screening assay for detecting pollutants in environmental water  
samples. Served as consultant for Brims Ness, Capricorn Products, Inc.,  
Maine Standards, and Enzo Biochem, Inc.

Visiting Scientist, Maine Medical Center Research Institute, 1994 to  
2000. Synthesized and characterized modified acridancarboxylic acid  
ester. Demonstrated substrate activity with HRPO. Invented and  
characterized activated 9-acridinecarboxylic acid derivatives.  
Demonstrated high sensitivity assay of glucose oxidase and alkaline  
phosphatase. HPLC of acridine derivatives. HPLC of synthetic  
oligonucleotides.

Research Scientist, IDEXX Laboratories, Inc., 1992 - 1993.  
Optimization of HRPO assay systems.

Staff Scientist, Gen-Probe, Inc., 1985 - 1992. Synthesized and designed acridinium esters. Helped design linker arms, optimize detection of acridinium esters, stabilize acridinium esters, improve elution of nucleic acids from solid supports. Characterized acridinium esters by HPLC, UV and chemiluminescence.

Research Associate, Department of Microbiology, University of Virginia, 1982 - 1985. Developed new DNA sequencing method similar to Sanger approach, but which leaves functional 3' ends, which can be ligated to produce a set of deletion mutants or can be extended under conditions forcing misincorporation to generate a set of point mutations. Synthesized series of 5'-thymidine triphosphate derivatives containing a 3'-phosphate mono-, di-, or triester group. Showed that these analogs were not substrates for T4 or Klenow DNA polymerase. Developed simple, rapid gel filtration method for purifying and desalting nucleotides. Synthesized an analog of dUTP containing an EDTA group and showed that it can be enzymatically incorporated into DNA.

Assistant Professor, Department of Chemistry, University of Virginia, 1980-1982. Prepared nucleotide derivatives of tubercidin. Characterized allylamine derivatives. Taught biophysical chemistry.

Postdoctoral Research Fellow, Department of Molecular Biophysics and Biochemistry (laboratory of Dr. David C. Ward), Yale University, 1977-1980. Synthesized modified pyrimidines to incorporate in vitro into nucleic acids, using reactions between heavy metals and nucleic acid components. Developed nucleotide analogs used for gene detection in situ. Biotinyl nucleotides now selling commercially.

Predoctoral Fellow, Department of Biophysics (laboratory of Dr. Michael Beer), Johns Hopkins University, Baltimore, Maryland, 1970-1977. Developed multiple heavy atom stains for electron microscopy of nucleic acids.

#### ACHIEVEMENTS

Co-inventor of non-radioactively-labeled nucleotides, including biotinyl nucleotides (U.S. Patents Nos. 4,711,955; 5,328,824; 5,449,767; and 5,476,928). Co-inventor of activated 9-acridinecarboxylic acid chemiluminescent system. Experienced in chemistry of nucleic acids and proteins, especially the synthetic chemistry of nucleotides, peptides, and their oligomers, and in the chemistry of mercury, osmium, and palladium; familiar with NMR, UV-Visible, IR, and fluorescent spectroscopic techniques, and with TLC, HPLC, gel filtration, and ion exchange chromatographic procedures; experienced in the use of DNA polymerases and nucleases. Experienced in detection systems for nucleic acids, especially chemiluminescence. Experienced in chemistry of acridine and

acridinium compounds. Experienced with several ELISA enzymes, including horseradish peroxidase (HRPO), alkaline phosphatase, glucose oxidase, and  $\beta$ -galactosidase.

#### Publications

- (1) Richardson, F.S., Shillady, D.D., Waldrop, A.A.; A Theoretical Study of Cis-Trans Photoisomerization in the Bis(Glycinato) Platinum(II) Complex, Inorganica Chimica Acta, 5, 279-289 (1971).
- (2) Waldrop, A.A., Beer, M., Marzilli, L.G.; Osmium-labeled Polynucleotides. Incorporation of Additional Heavy Atoms (Mercury) via Ligand Substitution Reactions, Journal of Inorganic Biochemistry, 10, 225-234 (1979).
- (3) Langer P.R., Waldrop, A.A., and Ward, D.C.; Enzymatic Synthesis of Polynucleotides Containing Biotin: Novel Nucleic Acid Affinity Probes, Proc. Natl. Acad. Sci. U.S.A., 78, 6633-6637 (1981).
- (4) Hammond, Philip W.; Wiese, Wendy A.; Waldrop, Alex A., III; Nelson, Norman C.; Arnold, Lyle J., Jr.; Nucleophilic Addition to the 9 Position Of 9-Phenylcarboxylate-10-Methylacridinium Protects Against Hydrolysis of the Ester, J. Biolumin. Chemilumin. 6(1), 35-43, (1991).
- (5) Waldrop, Alex A., III; Fellers, Jonathan; Vary, Calvin P. H.; Chemiluminescent Determination of Hydrogen Peroxide with 9-Acridinecarbonylimidazole and Use in Measurement of Glucose Oxidase and Alkaline Phosphatase Activity, Luminescence 15(3), 168-182, (2000).

#### Patents and Patent Applications

- (1) Ward, D.C., Langer, P.R., and Waldrop, A.A.; Modified Nucleotides and Methods of Preparing and Using Same, U.S. Patent 4,711,955 (December 8, 1987). (European Pat. Appl. EP 63879 A2)
- (2) Arnold, Lyle J., Waldrop, Alex A., III, Hammond, Philip W.; Protected Chemiluminescent Labels, U. S. Patent # 4,950,613 (Aug. 21, 1990). (European Pat. Appl. EP 330433 A2).
- (3) Ward, D.C., Langer, P.R., and Waldrop, A.A.; Methods of Using Labeled Nucleotides. U.S. Patent #5,328,824 (July 12, 1994).
- (4) Ward, D.C., Langer, P.R., and Waldrop, A.A.; Modified Polynucleotides and Methods of Preparing Same. U.S Patent #5,449,767 (Sept.12, 1995).
- (5) Ward, D.C., Langer, P.R., and Waldrop, A.A.; Modified Nucleotides and Polynucleotides and Complexes Form Therefrom. U.S Patent #5,476,928 (Dec.19, 1995).

- (6) Arnold, Lyle, J., Jr.; Nelson, Norman C.; Reynolds, Mark A.; Waldrop, Alex A., III; Polycationic Supports and Nucleic Acid Purification, Separation and Hybridization. U. S. Patent #5,599,667 (Feb 4, 1997). (European Pat. Appl. EP 281390 A2).
- (7) Waldrop, Alex A., III and Vary, C.P.H., Peroxide-Based Chemiluminescent Assays and Chemiluminescent Compounds Used Therein. Patent pending (Submitted 1997 as Provisional Patent Application).

\* \* \* \* \*

Claim 3144. (New) A non-porous solid support comprising at least one single-stranded nucleic acid directly or indirectly fixed or immobilized thereto in hybridizable form, wherein when said nucleic acid is indirectly fixed or immobilized to said non-porous solid support, said indirect fixation or immobilization is not to a cell fixed *in situ* to said non-porous solid support.

Claim 3145. (New) A non-porous solid support comprising at least one double-stranded nucleic acid fixed or immobilized thereto, wherein at least one nucleic acid strand of said double-stranded nucleic acid comprises at least one non-radioactive chemical label which is quantifiable or detectable, wherein when said nucleic acid is indirectly fixed or immobilized to said non-porous solid support, said indirect fixation or immobilization is not to a cell fixed *in situ* to said non-porous solid support.

Claim 3146. (New) The non-porous solid support of claim 3144 or 3145, wherein said non-porous solid support comprises glass or plastic.

Claim 3147. (New) The non-porous solid support of claim 3144 or 3145, wherein said non-porous solid support comprises a plate, a well or wells, a microtiter well or microtiter wells, depressions, tubes, cuvettes, beads, or a set of said plates, wells, depressions, tubes, cuvettes or beads.

Claim 3148. (New) The non-porous solid support of claim 3144 or 3145, wherein said non-porous solid support comprises more than one surface.

Claim 3149. (New) The non-porous solid support of claim 3144 or 3145, comprising reactive sites or binding sites thereon, wherein said nucleic acid is fixed or immobilized to one of said reactive sites or binding sites.

Claim 3150. (New) The non-porous solid support of claim 3149, wherein said reactive sites or binding sites comprise one or more amines, hydroxyls or epoxides.

Claim 3151. (New) The non-porous solid support of claim 3144 or 3145, wherein said non-porous solid support has been treated with a surface treatment agent, a blocking agent, or both.

Claim 3152. (New) The non-porous solid support of claim 3151, wherein said surface treatment agent comprises an amine providing compound, an epoxy glue or solution, an acid solution, or ammonium acetate.

Claim 3153. (New) The non-porous solid support of claim 3151, wherein said blocking agent comprises Denhardt's solution.

Claim 3154. (New) The non-porous solid support of claim 3144 or 3145, wherein said direct or indirect fixation or immobilization to said non-porous solid support is covalent.

Claim 3155. (New) The non-porous solid support of claim 3144 or 3145, wherein said direct or indirect fixation or immobilization to said non-porous solid support is non-covalent.

Claim 3156. (New) The non-porous solid support of claim 3144, wherein said single-stranded nucleic acid is indirectly fixed or immobilized to said non-porous solid support by sandwich hybridization or by hybridization to a complementary nucleic acid strand.



Claim 3157. (New) The non-porous solid support of claim 3145, wherein one strand of said double-stranded nucleic acid is indirectly fixed or immobilized to said non-porous solid support by sandwich hybridization or by hybridization to a complementary nucleic acid strand.

Claim 3158. (New) The non-porous solid support of claim 3144, wherein said nucleic acid comprises DNA or RNA.

Claim 3159. (New) The non-porous solid support of claim 3145, wherein said nucleic acid comprises DNA, RNA or both.

Claim 3160. (New) The non-porous solid support of claim 3144, wherein said nucleic acid comprises a nucleic acid sequence complementary to a nucleic acid sequence of interest sought to be identified, quantified or sequenced.

Claim 3161. (New) The non-porous solid support of claim 3145, wherein one strand of said double-stranded nucleic acid comprises a nucleic acid sequence of interest sought to be identified, quantified or sequenced.

Claim 3162. (New) The non-porous solid support of claim 3144, wherein said single-stranded nucleic acid is unlabeled.

Claim 3163. (New) The non-porous solid support of claim 3144 or 3145, wherein said non-porous solid support is transparent or translucent.

Claim 3164. (New) The non-porous solid support of claim 3145, wherein said non-radioactive chemical label is quantifiable in or from a fluid or solution, said quantity being proportional to the amount or quantity of said label or labels.

Claim 3165. (New) The non-porous solid support of claim 3145, wherein said non-porous solid support is transparent or translucent, and said non-radioactive chemical label is quantifiable in or from a fluid or solution or in or through said non-porous solid support, said quantity being proportional to the amount or quantity of said label or labels.

Claim 3166. (New) The non-porous solid support of claim 3145, wherein said non-radioactive chemical label comprises a chromagen or a chromagenic compound, a colored dye compound, a fluorogen or a fluorescent compound, a chemiluminescent compound, a chelating compound, an enzyme or an enzymatic compound, a coenzyme, biotin, iminobiotin, a hapten or a ligand.

Claim 3167. (New) The non-porous solid support of claim 3145, wherein a non-radioactive signal from said non-radioactive chemical label is quantifiable or detectable by photometric techniques, spectrophotometric techniques, colorimetric techniques, fluorometric techniques or chemiluminescent techniques.

Claim 3168. (New) The non-porous solid support of claim 3144, comprising more than one single-stranded nucleic acid.

Claim 3169. (New) The non-porous solid support of claim 3145, comprising more than one double-stranded nucleic acid.

Claim 3170. (New) A set comprising the non-porous solid support of claim 3144.

Claim 3171. (New) A set comprising the non-porous solid support of claim 3145.

Claim 3172. (New) A system comprising a non-porous solid support and at least one single-stranded nucleic acid directly or indirectly fixed or immobilized thereto in hybridizable form, wherein when said nucleic acid is indirectly fixed or immobilized to said non-porous solid support, said indirect fixation or immobilization is not to a cell fixed *in situ* to said non-porous solid support.

Claim 3173. (New) A system comprising a non-porous solid support and at least one double-stranded nucleic acid fixed or immobilized thereto, wherein at least one nucleic acid strand of said double-stranded nucleic acid comprises at least one non-radioactive chemical label which is quantifiable or detectable, and wherein when said nucleic acid is indirectly fixed or immobilized to said non-porous solid support, said indirect fixation or immobilization is not to a cell fixed *in situ* to said non-porous solid support.

Claim 3174. (New) The system of claim 3172 or 3173, wherein said non-porous solid support comprises glass or plastic.

Claim 3175. (New) The system of claim 3172 or 3173, wherein said non-porous solid support comprises a plate, a well or wells, a microtiter well or microtiter wells, depressions, tubes, cuvettes, beads, or a set of said plates, wells, depressions, tubes, cuvettes or beads.

Claim 3176. (New) The system of claim 3172 or 3173, wherein said non-porous solid support comprises more than one surface.

Claim 3177. (New) The system of claim 3172 or 3173, wherein said non-porous solid support comprises reactive sites or binding sites thereon, wherein said nucleic acid is fixed or immobilized to one of said reactive sites or binding sites.

Claim 3178. (New) The system of claim 3177, wherein said reactive sites or binding sites comprise one or more amines, hydroxyls or epoxides.

Claim 3179. (New) The system of claim 3172 or 3173, wherein said non-porous solid support has been treated with a surface treatment agent, a blocking agent, or both.

Claim 3180. (New) The system of claim 3179, wherein said surface treatment agent comprises an amine providing compound, an epoxy glue or solution, an acid solution or ammonium acetate.

Claim 3181. (New) The system of claim 3179, wherein said blocking agent comprises Denhardt's solution.

Claim 3182. (New) The system of claim 3172 or 3173, wherein said direct or indirect fixation or immobilization to said non-porous solid support is covalent.

Claim 3183. (New) The system of claim 3172 or 3173, wherein said direct or indirect fixation or immobilization to said non-porous solid support is non-covalent.

Claim 3184. (New) The system of claim 3172, wherein said single-stranded nucleic acid is indirectly fixed or immobilized to said non-porous solid support by sandwich hybridization or by hybridization to a complementary nucleic acid strand.

Claim 3185. (New) The system of claim 3173, wherein said one strand of said double-stranded nucleic acid is indirectly fixed or immobilized to said non-porous solid support by sandwich hybridization or by hybridization to a complementary nucleic acid strand.

Claim 3186. (New) The system of claim 3172, wherein said nucleic acid comprises DNA or RNA.

Claim 3187. (New) The system of claim 3173, wherein said nucleic acid comprises DNA, RNA, or both.

Claim 3188. (New) The system of claim 3172, wherein said nucleic acid comprises a nucleic acid sequence complementary to a nucleic acid sequence of interest sought to be identified, quantified or sequenced.

Claim 3189. (New) The system of claim 3173, wherein one strand of said double-stranded nucleic acid comprises a nucleic acid sequence of interest sought to be identified, quantified or sequenced.

Claim 3190. (New) The system of claim 3172, wherein said single-stranded nucleic acid is unlabeled.

Claim 3191. (New) The system of claim 3172 or 3173, wherein said non-porous solid support is transparent or translucent.

Claim 3192. (New) The system of claim 3173, wherein said non-radioactive chemical label is quantifiable in or from a fluid or solution, said quantity being proportional to the amount or quantity of said label or labels.

Claim 3193. (New) The system of claim 3173, wherein said non-porous solid support is transparent or translucent, and said non-radioactive chemical label is quantifiable in or from a fluid or solution or in or through said non-porous solid support, said quantity being proportional to the amount or quantity of said label or labels.

Claim 3194. (New) The system of claim 3173, wherein said non-radioactive chemical label comprises a chromagen or a chromagenic compound, a colored dye compound, a fluorogen or a fluorescent compound, a chemiluminescent compound, a chelating compound, an enzyme or an enzymatic compound, a coenzyme, biotin, iminobiotin, a hapten or a ligand.

Claim 3195. (New) The system of claim 3173, wherein a non-radioactive signal from said non-radioactive chemical label is quantifiable or detectable by photometric techniques, spectrophotometric techniques, colorimetric techniques, fluorometric techniques or chemiluminescent techniques.

Claim 3196. (New) The system of claim 3172, comprising more than one single-stranded nucleic acid.

Claim 3197. (New) The system of claim 3173, comprising more than one double-stranded nucleic acid.

Claim 3198. (New) An array comprising various single-stranded nucleic acids directly or indirectly fixed or immobilized in hybridizable form to a non-porous solid support, wherein when said nucleic acids are indirectly fixed or immobilized to said non-porous solid support, said indirect fixation or immobilization is not to a cell fixed *in situ* to said non-porous solid support.

Claim 3199. (New) An array comprising various double-stranded nucleic acids directly or indirectly fixed or immobilized to a non-porous solid support, wherein at least one nucleic acid strand of said various double-stranded nucleic acids comprises at least one non-radioactive chemical label which is quantifiable or detectable, and wherein when said nucleic acids are indirectly fixed or immobilized to said non-porous solid support, said indirect fixation or immobilization is not to a cell fixed *in situ* to said non-porous solid support.

Claim 3200. (New) The array of claim 3198 or 3199, wherein said non-porous solid support comprises glass or plastic.

Claim 3201. (New) The array of claim 3198 or 3199, wherein said non-porous solid support comprises a plate, a well or wells, a microtiter well or microtiter wells, depressions, tubes, cuvettes, beads, or a set of said plates, wells, depressions, tubes, cuvettes or beads.

Claim 3202. (New) The array of claim 3198 or 3199, wherein said non-porous solid support comprises more than one surface.

Claim 3203. (New) The array of claim 3198 or 3199, comprising reactive sites or binding sites thereon, wherein said nucleic acids are fixed or immobilized to said reactive sites or binding sites.

Claim 3204. (New) The array of claim 3203, wherein said reactive sites or binding sites comprise one or more amines, hydroxyls or epoxides.

Claim 3205. (New) The array of claim 3198 or 3199, wherein said non-porous solid support has been treated with a surface treatment agent, a blocking agent, or both.

Claim 3206. (New) The array of claim 3205, wherein said surface treatment agent comprises an amine providing compound, an epoxy glue or solution, an acid solution or ammonium acetate.

Claim 3207. (New) The array of claim 3205, wherein said blocking agent comprises Denhardt's solution.

Claim 3208. (New) The array of claim 3198 or 3199, wherein said direct or indirect fixation or immobilization to said non-porous solid support is covalent

Claim 3209. (New) The array of claim 3198 or 3199, wherein said direct or indirect fixation or immobilization to said non-porous solid support is non-covalent.

Claim 3210. (New) The array of claim 3198, wherein said single-stranded nucleic acids or sequences are indirectly fixed or immobilized to said non-porous solid support by sandwich hybridization or by hybridization to complementary nucleic acid strands.



Claim 3211. (New) The array of claim 3199, wherein one strand of said double-stranded nucleic acids or sequences is indirectly fixed or immobilized to said non-porous solid support by sandwich hybridization or by hybridization to complementary nucleic acid strands.

Claim 3212. (New) The array of claim 3198, wherein said nucleic acids comprise DNA or RNA.

Claim 3213. (New) The array of claim 3199, wherein said nucleic acids comprise DNA, RNA, or both.

Claim 3214. (New) The array of claim 3198, wherein said nucleic acids comprise nucleic acid sequences complementary to nucleic acid sequences of interest sought to be identified, quantified or sequenced.

Claim 3215. (New) The array of claim 3199, wherein one strand of said double-stranded nucleic acids comprises a nucleic acid sequence of interest sought to be identified, quantified or sequenced.

Claim 3216. (New) The array of claim 3198, wherein said single-stranded nucleic acids are unlabeled.

Claim 3217. (New) The array of claim 3198 or 3199, wherein said non-porous solid support is transparent or translucent.

Claim 3218. (New) The array of claim 3199, wherein said non-radioactive chemical label is quantifiable in or from a fluid or solution, said quantity being proportional to the amount or quantity of said label or labels.

Claim 3219. (New) The array of claim 3199, wherein said non-porous solid support is transparent or translucent, and said non-radioactive chemical label is quantifiable in or from a fluid or solution or in or through said non-porous solid support, said quantity being proportional to the amount or quantity of said label or labels.

Claim 3220. (New) The array of claim 3199, wherein said non-radioactive chemical label comprises a chromagen or a chromagenic compound, a colored dye compound, a fluorogen or a fluorescent compound, a chemiluminescent compound, a chelating compound, an enzyme or an enzymatic compound, a coenzyme, biotin, iminobiotin, a hapten or a ligand.

Claim 3221. (New) The array of claim 3199, wherein a non-radioactive signal from said non-radioactive chemical label is quantifiable or detectable by photometric techniques, spectrophotometric techniques, colorimetric techniques, fluorometric techniques or chemiluminescent techniques.

Claim 3222. (New) An array comprising various single-stranded nucleic acids directly or indirectly fixed or immobilized in hybridizable form to a non-porous solid support having wells or depressions, wherein when said nucleic acids are indirectly fixed or immobilized to said wells or depressions of said non-porous solid support, said indirect fixation or immobilization is not to a cell fixed *in situ* to said wells or depressions of said non-porous solid support.

Claim 3223. (New) An array comprising various double-stranded nucleic acids directly or indirectly fixed or immobilized to a non-porous solid support having wells or depressions, wherein at least one nucleic acid strand of said various double-stranded nucleic acids comprises at least one non-radioactive chemical label which is quantifiable or detectable, and wherein when said nucleic acids are indirectly fixed or immobilized to said wells or depressions of said non-porous solid support, said indirect fixation or immobilization is not to a cell fixed *in situ* to said wells or depressions of said non-porous solid support.

Claim 3224. (New) The array of claim 3222 or 3223, wherein said non-porous solid support comprises glass or plastic.

Claim 3225. (New) The array of claim 3222 or 3223, wherein said wells or depressions comprise a plate of wells or depressions, or a microtiter plate of wells or depressions.

Claim 3226. (New) The array of claim 3222 or 3223, comprising reactive sites or binding sites thereon, wherein said nucleic acids are fixed or immobilized to said reactive sites or binding sites.

Claim 3227. (New) The array of claim 3226, wherein said reactive sites or binding sites comprise one or more amines, hydroxyls or epoxides.

Claim 3228. (New) The array of claim 3222 or 3223, wherein said non-porous solid support has been treated with a surface treatment agent, a blocking agent, or both.

Claim 3229. (New) The array of claim 3228, wherein said surface treatment agent comprises an amine providing compound, an epoxy glue or solution, an acid solution or ammonium acetate.

Claim 3230. (New) The array of claim 3228, wherein said blocking agent comprises Denhardt's solution.

Claim 3231. (New) The array of claim 3222 or 3223, wherein said direct or indirect fixation or immobilization to said non-porous solid support is covalent.

Claim 3232. (New) The array of claim 3222 or 3223, wherein said direct or indirect fixation or immobilization to said non-porous solid support is non-covalent.

Claim 3233. (New) The array of claim 3222, wherein said single-stranded nucleic acids are indirectly fixed or immobilized to said non-porous solid support by sandwich hybridization or by hybridization to complementary nucleic acid strands.

Claim 3234. (New) The array of claim 3223, wherein one strand of said double-stranded nucleic acids is indirectly fixed or immobilized to said non-porous solid support by sandwich hybridization or by hybridization to complementary nucleic acid strands.

Claim 3235. (New) The array of claim 3222, wherein said nucleic acids comprise DNA or RNA.

Claim 3236. (New) The array of claim 3223, wherein said nucleic acids comprise DNA, RNA, or both.

Claim 3237. (New) The array of claim 3222, wherein said nucleic acids comprise nucleic acid sequences complementary to nucleic acid sequences of interest sought to be identified, quantified or sequenced.

Claim 3238. (New) The array of claim 3223, wherein one strand of said double-stranded nucleic acids comprises a nucleic acid sequence of interest sought to be identified, quantified or sequenced.

Claim 3239. (New) The array of claim 3223, wherein said nucleic acid sequence of interest sought to be identified, quantified or sequenced comprises a gene sequence or pathogen sequence.

Claim 3240. (New) The array of claim 3222, wherein said single-stranded nucleic acids are unlabeled.

Claim 3241. (New) The array of claim 3222 or 3223, wherein said non-porous solid support is transparent or translucent.

Claim 3242. (New) The array of claim 3223, wherein said non-radioactive chemical label is quantifiable in or from a fluid or solution, said quantity being proportional to the amount or quantity of said label or labels.

Claim 3243. (New) The array of claim 3223, wherein said non-porous solid support is transparent or translucent, and said non-radioactive chemical label is quantifiable in or from a fluid or solution or in or through said non-porous solid support, said quantity being proportional to the amount or quantity of said label or labels.

Claim 3244. (New) The array of claim 3223, wherein said non-radioactive chemical label comprises a chromagen or a chromagenic compound, a colored dye compound, a fluorogen or a fluorescent compound, a chemiluminescent compound, a chelating compound, an enzyme or an enzymatic compound, a coenzyme, biotin, iminobiotin, a hapten or a ligand.

Claim 3245. (New) The array of claim 3223, wherein a non-radioactive signal from said non-radioactive chemical label is quantifiable or detectable by photometric techniques, spectrophotometric techniques, colorimetric techniques, fluorometric techniques or chemiluminescent techniques.

Claim 3246. (New) A non-porous glass or plastic solid support comprising at least one single-stranded nucleic acid directly or indirectly fixed or immobilized thereto in hybridizable form, wherein when said single-stranded nucleic acid is indirectly fixed or immobilized to said non-porous glass or plastic solid support, said indirect fixation or immobilization is not to a cell fixed *in situ* to said non-porous glass or plastic solid support.

Claim 3247. (New) A non-porous glass or plastic solid support comprising at least one double-stranded nucleic acid directly or indirectly fixed or immobilized thereto, wherein at least one nucleic acid strand of said double-stranded nucleic acid comprises at least one non-radioactive chemical label which is quantifiable or detectable, and wherein when said double-stranded nucleic acid is indirectly fixed or immobilized to said non-porous glass or plastic solid support, said indirect fixation or immobilization is not to a cell fixed *in situ* to said non-porous glass or plastic solid support.

Claim 3248. (New) The non-porous glass or plastic solid support of claim 3246 or 3247, wherein said non-porous glass or plastic solid support comprises a plate, a well or wells, a microtiter well or microtiter wells, depressions, tubes, cuvettes, beads, or a set of said plates, wells, depressions, tubes, cuvettes or beads.

Claim 3249. (New) The non-porous glass or plastic solid support of claim 3246 or 3247, wherein said non-porous solid support comprises more than one surface.

Claim 3250. (New) The non-porous glass or plastic solid support of claim 3246 or 3247, comprising reactive sites or binding sites thereon, wherein said nucleic acid is fixed or immobilized to one of said reactive sites or binding sites.

Claim 3251. (New) The non-porous glass or plastic solid support of claim 3250, wherein said reactive sites or binding sites comprise one or more amines, hydroxyls or epoxides.

Claim 3252. (New) The non-porous glass or plastic solid support of claim 3246 or 3247, wherein said non-porous glass or plastic solid support has been treated with a surface treatment agent, a blocking agent, or both.

Claim 3253. (New) The non-porous glass or plastic solid support of claim 3252, wherein said surface treatment agent comprises an amine providing compound, an epoxy glue or solution, an acid solution or ammonium acetate.

Claim 3254. (New) The non-porous glass or plastic solid support of claim 3252, wherein said blocking agent comprises Denhardt's solution.

Claim 3255. (New) The non-porous glass or plastic solid support of claim 3246 or 3247, wherein said direct or indirect fixation or immobilization to said non-porous solid support is covalent

Claim 3256. (New) The non-porous glass or plastic solid support of claim 3246 or 3247, wherein said direct or indirect fixation or immobilization to said non-porous solid support is non-covalent.

Claim 3257. (New) The non-porous glass or plastic solid support of claim 3246, wherein said single-stranded nucleic acid is indirectly fixed or immobilized to said non-porous glass or plastic solid support by sandwich hybridization or by hybridization to a complementary nucleic acid strand.

Claim 3258. (New) The non-porous glass or plastic solid support of claim 3247, wherein one strand of said double-stranded nucleic acid is indirectly fixed or immobilized to said non-porous glass or plastic solid support by sandwich hybridization or by hybridization to a complementary nucleic acid strand.

Claim 3259. (New) The non-porous glass or plastic solid support of claim 3246, wherein said nucleic acid or sequence comprises DNA or RNA.

Claim 3260. (New) The non-porous glass or plastic solid support of claim 3247, wherein said nucleic acid or sequence comprises DNA, RNA, or both.

Claim 3261. (New) The non-porous glass or plastic solid support of claim 3246, wherein said nucleic acid comprises a nucleic acid sequence complementary to a nucleic acid sequence of interest sought to be identified, quantified or sequenced.



Claim 3262. (New) The non-porous glass or plastic solid support of claim 3247, wherein one strand of said double-stranded nucleic acid comprises a nucleic acid sequence of interest sought to be identified, quantified or sequenced.

Claim 3263. (New) The non-porous glass or plastic solid support of claim 3246, wherein said single-stranded nucleic acid is unlabeled.

Claim 3264. (New) The non-porous glass or plastic solid support of claim 3246 or 3247, wherein said non-porous glass or plastic solid support is transparent or translucent.

Claim 3265. (New) The non-porous glass or plastic solid support of claim 3247, wherein said non-radioactive chemical label is quantifiable in or from a fluid or solution, said quantity being proportional to the amount or quantity of said label or labels.

Claim 3266. (New) The non-porous glass or plastic solid support of claim 3247, wherein said non-porous glass or plastic solid support is transparent or translucent, and non-radioactive chemical label is quantifiable in or from a fluid or solution or in or through said non-porous glass or plastic solid support, said quantity being proportional to the amount or quantity of said label or labels.

Claim 3267. (New) The non-porous glass or plastic solid support of claim 3246, comprising more than one single-stranded nucleic acids directly or indirectly fixed or immobilized in hybridizable form to said non-porous glass or plastic solid support.

Claim 3268. (New) The non-porous glass or plastic solid support of claim 3247, comprising more than one double-stranded nucleic acids directly or indirectly fixed or immobilized in hybridizable form to said non-porous glass or plastic solid support.

Claim 3269. (New) A set comprising the non-porous glass or plastic solid supports of claim 3246.

Claim 3270. (New) A set comprising the non-porous glass or plastic solid supports of claim 3247.

Claim 3271. (New) A non-porous solid support comprising single-stranded nucleic acid directly or indirectly fixed or immobilized thereto in hybridizable form, wherein when said nucleic acid is indirectly fixed or immobilized to said non-porous solid support, said indirect fixation or immobilization is not to a cell fixed *in situ* to said non-porous solid support.

Claim 3272. (New) A non-porous solid support comprising a single-stranded nucleic acid directly or indirectly fixed or immobilized thereto in hybridizable form, wherein when said nucleic acid is indirectly fixed or immobilized to said non-porous solid support, said indirect fixation or immobilization is not to a cell fixed *in situ* to said non-porous solid support.

Claim 3273. (New) A non-porous solid support comprising nucleic acid directly or indirectly fixed or immobilized thereto in hybridizable form, wherein when said nucleic acid is indirectly fixed or immobilized to said non-porous solid support, said indirect fixation or immobilization is not to a cell fixed *in situ* to said non-porous solid support.

Claim 3274. (New) A non-porous solid support comprising DNA or RNA directly or indirectly fixed or immobilized thereto in hybridizable form, wherein when said DNA or RNA is indirectly fixed or immobilized to said non-porous solid support, said indirect fixation or immobilization is not to a cell fixed *in situ* to said non-porous solid support.

Claim 3275. (New) A non-porous solid support comprising double-stranded nucleic acid fixed or immobilized thereto, wherein at least one nucleic acid strand of said double-stranded nucleic acid comprises at least one non-radioactive chemical label which is quantifiable or detectable, wherein when said nucleic acid is indirectly fixed or immobilized to said non-porous solid support, said indirect fixation or immobilization is not to a cell fixed *in situ* to said non-porous solid support.

Claim 3276. (New) A non-porous solid support comprising a double-stranded nucleic acid fixed or immobilized thereto, wherein at least one nucleic acid strand of said double-stranded nucleic acid comprises at least one non-radioactive chemical label which is quantifiable or detectable, wherein when said nucleic acid is indirectly fixed or immobilized to said non-porous solid support, said indirect fixation or immobilization is not to a cell fixed *in situ* to said non-porous solid support.

Claim 3277. (New) The non-porous solid support of claim 3271, 3272, 3273, 3274, 3275, or 3276, wherein said non-porous solid support comprises glass or plastic.

Claim 3278. (New) The non-porous solid support of claim 3271, 3272, 3273, 3274, 3275, or 3276, wherein said non-porous solid support comprises more than one surface.

Claim 3279. (New) A system comprising a non-porous solid support and DNA or RNA directly or indirectly fixed or immobilized thereto in hybridizable form, wherein when said DNA or RNA is indirectly fixed or immobilized to said non-porous solid support, said indirect fixation or immobilization is not to a cell fixed *in situ* to said non-porous solid support.

Claim 3280. (New) A system comprising a non-porous solid support and nucleic acid directly or indirectly fixed or immobilized thereto in hybridizable form, wherein when said nucleic acid is indirectly fixed or immobilized to said non-porous solid support, said indirect fixation or immobilization is not to a cell fixed *in situ* to said non-porous solid support.

Claim 3281. (New) A system comprising a non-porous solid support and double-stranded nucleic acid fixed or immobilized thereto, wherein at least one nucleic acid strand of said double-stranded nucleic acid comprises at least one non-radioactive chemical label which is quantifiable or detectable, and wherein when said nucleic acid is indirectly fixed or immobilized to said non-porous solid support, said indirect fixation or immobilization is not to a cell fixed *in situ* to said non-porous solid support.

Claim 3282. (New) A system comprising a non-porous solid support and a double-stranded nucleic acid fixed or immobilized thereto, wherein at least one nucleic acid strand of said double-stranded nucleic acid comprises at least one non-radioactive chemical label which is quantifiable or detectable, and wherein when said nucleic acid is indirectly fixed or immobilized to said non-porous solid support, said indirect fixation or immobilization is not to a cell fixed *in situ* to said non-porous solid support.

Claim 3283. (New) The system of claim 3279, 3280, 3281 or 3282, wherein said non-porous solid support comprises glass or plastic.

Claim 3284. (New) A non-porous solid support comprising nucleic acid directly fixed or immobilized thereto in hybridizable form.

Claim 3285. (New) A non-porous solid support comprising a nucleic acid directly fixed or immobilized thereto in hybridizable form.

Claim 3286. (New) A non-porous solid support comprising DNA or RNA directly fixed or immobilized thereto in hybridizable form.

\* \* \* \* \*

# Colony hybridization: A method for the isolation of cloned DNAs that contain a specific gene

(*Drosophila melanogaster* DNA/recombinant DNA molecules/plasmids/18-28S rRNA genes/autoradiography)

MICHAEL GRUNSTEIN\* AND DAVID S. HOGNESS†

Department of Biochemistry, Stanford University School of Medicine, Stanford, California 94305

Communicated by A. D. Kaiser, August 4, 1975

**ABSTRACT** A method has been developed whereby a very large number of colonies of *Escherichia coli* carrying different hybrid plasmids can be rapidly screened to determine which hybrid plasmids contain a specified DNA sequence or genes. The colonies to be screened are formed on nitrocellulose filters, and, after a reference set of these colonies has been prepared by replica plating, are lysed and their DNA is denatured and fixed to the filter *in situ*. The resulting DNA-prints of the colonies are then hybridized to a radioactive RNA that defines the sequence or gene of interest, and the result of this hybridization is assayed by autoradiography. Colonies whose DNA-prints exhibit hybridization can then be picked from the reference plate. We have used this method to isolate clones of ColE1 hybrid plasmids that contain *Drosophila melanogaster* genes for 18 and 28S rRNAs. In principle, the method can be used to isolate any gene whose base sequence is represented in an available RNA.

Segments of DNA from *Drosophila melanogaster* chromosomes (Dm segments) can be isolated by cloning hybrid DNA molecules that consist of a Dm segment inserted into the circular DNA of an *Escherichia coli* plasmid. We have previously reported on the use of such cloned segments in the analysis of DNA sequence arrangements in the *D. melanogaster* genome (1-3). However, that analysis has been limited by our inability to isolate cloned Dm segments that contain a specified DNA sequence or gene. In this article we describe a procedure that permits the isolation of such specific Dm segments, and which can be extended to DNA segments from any organism.

**Experimental Plan.** Consider an experiment in which the Dm segments in a random set are individually inserted into a given *E. coli* plasmid. Transformation of *E. coli* by these hybrid plasmids to a phenotype conferred by genes in the parental plasmid will yield colonies that individually contain a single cloned Dm segment (1-3). If these segments are randomly distributed and exhibit a mean length of 10,000 base pairs, or 10 kb, then we expect that about one colony in 16,000 will contain a particular nonrepetitive *D. melanogaster* DNA sequence the length of a typical structural gene, i.e., 1-2 kb. Hence, the goal is to devise a screening procedure whereby one can rapidly determine which colony in thousands contains such a sequence.

The screening procedure that we have developed is designed to detect sequences that can hybridize with a given

Abbreviations: kb (kilobases), 1000 bases or base pairs in single- or double-stranded nucleic acids, respectively; Dm, a segment of *Drosophila melanogaster* DNA; cDm and pDm, hybrid plasmids consisting of a Dm segment inserted into ColE1 and pSC101 DNAs, respectively; SSC = 0.15 M NaCl, 0.015 M sodium citrate; cRNA, RNA complementary to DNA; rDNA, DNA coding for ribosomal RNA.

\* Present address: Molecular Biology Institute and Department of Biology, University of California, Los Angeles, Calif. 90024.

† To whom reprint requests should be sent.

radioactive RNA. In this procedure the colonies to be screened are first grown on nitrocellulose filters that have been placed on the surface of agar petri plates prior to inoculation. A reference set of these colonies is then obtained by replica plating (4) to additional agar plates that are stored at 2-4°C. The colonies on the filter are lysed and their DNAs are denatured and fixed to the filter *in situ* to form a "DNA-print" of each colony. The defining, labeled RNA is hybridized to this DNA and the result of the hybridization is monitored by autoradiography on x-ray film. The colony whose DNA-print exhibits hybridization with the defining RNA can then be picked from the reference set.

The characteristics of this procedure and its application to the isolation of hybrid plasmids containing the *D. melanogaster* genes for '18' and '28S' rRNAs are described in this paper.

## MATERIALS AND METHODS

**Bacteria.** *E. coli* K12 strains HB101, HB101 [pDm103], and C600 [pSC101] are those used previously (plasmids are indicated in brackets) (3). Strain W3110 has been described (5), and W3110 [ColE1] was obtained from D. R. Helinski.

**DNAs, Complementary RNAs (cRNAs), and Enzymes.** pDm103 (3) and ColE1 (6) DNAs were generously provided by D. M. Glover and D. J. Finnegan, respectively, and were prepared from HB101 [pDm103] and W3110 [ColE1] according to the indicated references, except that the ColE1 was amplified by overnight incubation of W3110 [ColE1] in the presence of chloramphenicol (7) prior to lysis. <sup>32</sup>P- and <sup>3</sup>H-labeled cRNAs were transcribed *in vitro* from these DNAs with *E. coli* RNA polymerase (8), as described by Wensink *et al.* (1). The RNA polymerase was prepared according to the indicated reference, and was the generous gift of W. Wickner. Pancreatic ribonuclease and proteinase K were obtained from Worthington Biochemical Corp. and E. Merck Laboratories, respectively.

## Colony hybridization

**Formation of the Filter and Reference Sets of Colonies.** Colonies are formed on Millipore HA filters (0.45 μm pores) that have been washed three times in boiling H<sub>2</sub>O (1 min per wash), placed between sheets of absorbant paper, autoclaved at 120° for 10 min, and dried for 10 min in the autoclave. The filter is then placed on an L-agar petri plate (1) and the desired bacteria are transferred to the filter surface either by spreading or using sterile toothpicks to obtain ≤7 colonies per cm<sup>2</sup> after incubation of the filter-plate at 37°. The reference set is produced by replica plating of the colonies that develop on the filter to L-agar plates and is stored at 2-4°.

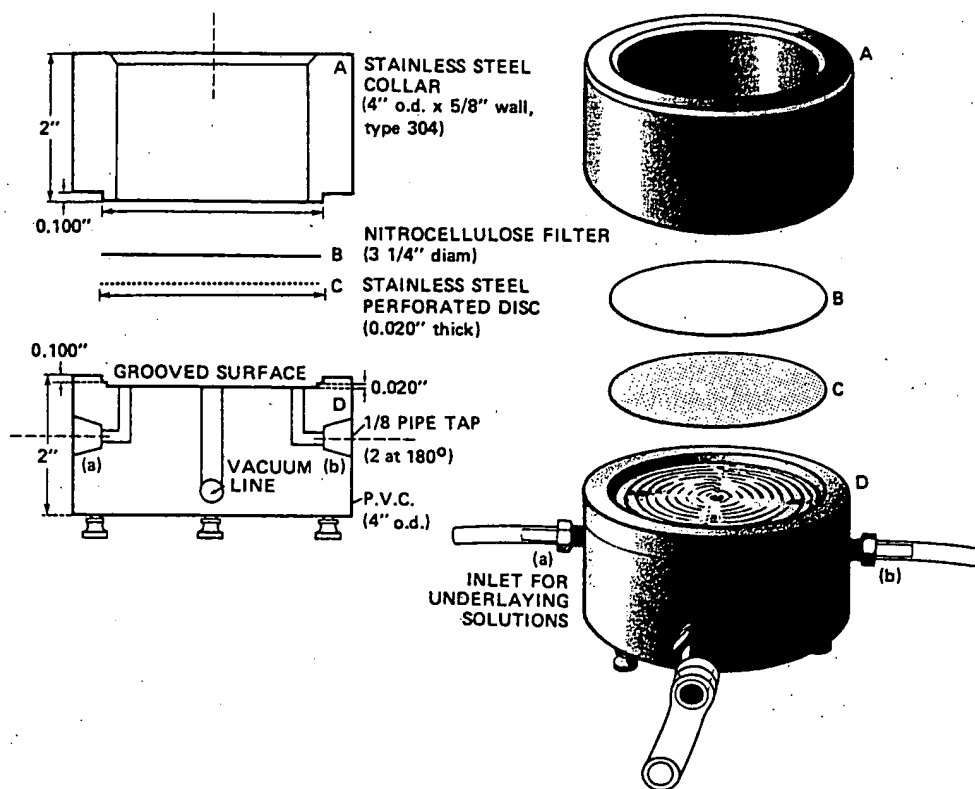

FIG. 1. Apparatus for treatment of colonies on filters. To wet the underside of the filter, solutions are introduced through ports (a) or (b), while the tube connected to the vacuum port is clamped off. Solutions are removed through the vacuum port which is connected to a water aspirator. Other procedures are described in the text. ", inches (2.54 cm); o.d., outside diameter; P.V.C., polyvinyl chloride.

**Lysis, DNA Denaturation, and Fixation.** To prevent movement of the bacteria or DNA from their colonial sites during lysis, denaturation and fixation, the solutions used to effect these reactions are applied to the underside of the filter and allowed to diffuse into the colony. The apparatus shown in Fig. 1 has been designed for this purpose. The filter is lifted from the agar plate and placed on the perforated disc that is set in a plastic cylinder which has ports cut into it to introduce solutions sequentially to the underside of the filter and to apply vacuum. Unless otherwise indicated, all operations are carried out at room temperature (20–25°).

Lysis and DNA denaturation are effected by introducing 0.5 N NaOH beneath the filter until it barely floats. After 7 min the NaOH is slowly removed with a minimum of vacuum, and replaced by 1.0 M Tris-HCl (pH 7.4) for 1 min. This solution is replaced with the same buffer, after which the pH of the solution in contact with the filter should be approximately neutral. The last wash is replaced by 1.5 M NaCl, 0.5 M Tris-HCl (pH 7.4), which is removed after 5 min. The stainless steel collar is then placed over the filter, and full vacuum is applied for approximately 2 min until the colonial residues assume a dry appearance. At this point there is less danger of movement from the colonial site and the remaining solutions can be layered on the upper side of the filter.

A 2 mg/ml solution of proteinase K in 1 × SSC (0.15 M NaCl, 0.015 M sodium citrate) is added to just cover the filter. After 15 min, it is removed by vacuum filtration, and 95% ethanol (1 ml/cm<sup>2</sup> of filter) is similarly passed through the filter. After five washes effected by passing chloroform through the filter (2 ml/cm<sup>2</sup> per wash), the filter is removed from the apparatus, dipped into 0.3 M NaCl to remove loose cellular debris, and baked at 80° *in vacuo* for 2 hr.

**Hybridization and <sup>32</sup>P-Autoradiography or <sup>3</sup>H-Fluorography.** The dry filter is moistened with a 5 × SSC, 50% formamide solution containing the labeled RNA, using 10–15 μl/cm<sup>2</sup> of filter. The filter is covered with mineral oil, incubated for 16 hr at 37° to allow hybridization, and then washed for 10 min in a beaker containing chloroform that is gently agitated on a shaking platform. Two more identical chloroform washes are followed by 10 min washes in 6 × SSC, 2 × SSC, and 2 × SSC containing 20 μg/ml of pancreatic ribonuclease. If the RNA is <sup>32</sup>P-labeled, the filter is blotted to remove excess liquid, covered with Saran Wrap, and placed under Kodak RPS/54 x-ray film for autoradiography. If the RNA is <sup>3</sup>H-labeled, the filter is dried for 30 min at 80° *in vacuo*, and 40 μl of 7% 2,5-diphenyloxazole (PPO) in ether is applied per cm<sup>2</sup> of filter. The dry filter is then placed under x-ray film for fluorography at –82° (9).

## RESULTS

### Colony hybridization distinguishes between [ColE1]<sup>+</sup> and [ColE1]<sup>–</sup> bacteria

We have turned increasingly toward the use of the colicinogenic plasmid, ColE1, as a cloning vector because one can obtain much higher cellular concentrations of its hybrids (7) than is the case for the tetracycline resistance plasmid, pSC101, which we used previously (1–3). The first test system for colony hybridization therefore consisted of <sup>32</sup>P-labeled cRNA made by transcription of ColE1 DNA *in vitro* with *E. coli* RNA polymerase, and *E. coli* containing or not containing ColE1, i.e., [ColE1]<sup>+</sup> or [ColE1]<sup>–</sup> bacteria.

Fig. 2A shows the autoradiographic response obtained after hybridization of [<sup>32</sup>P]cRNA to the DNA-prints of [ColE1]<sup>+</sup> and [ColE1]<sup>–</sup> colonies formed on nitrocellulose fil-

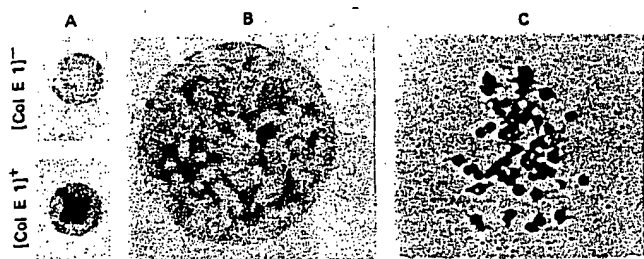

FIG. 2. Hybridization of ColE1 cRNA to [ColE1]<sup>-</sup> and [ColE1]<sup>+</sup> colonies. The procedures for colony hybridization, autoradiography, and fluorography are described in *Materials and Methods*, as are the W3310 and W3110 [ColE1] *E. coli* strains used to form the [ColE1]<sup>-</sup> and [ColE1]<sup>+</sup> colonies, respectively. (A) 1 × 10<sup>5</sup> cpm of [<sup>32</sup>P]cRNA (5 × 10<sup>7</sup> cpm/μg) were applied to each 13-mm filter (area = 1.3 cm<sup>2</sup>) in a 20 μl volume. After hybridization, the DNA-prints of [ColE1]<sup>+</sup> colonies contained an average of 1.8 × 10<sup>2</sup> cpm per colony, which is 30-fold greater than the background radiation from an equivalent area on the filter. Exposure time = 45 min. (B) A mixture of [ColE1]<sup>+</sup> and [ColE1]<sup>-</sup> bacteria in a 1:100 ratio was spread on a 47-mm filter (area = 17.3 cm<sup>2</sup>) to obtain a total of 1 to 2 × 10<sup>2</sup> colonies per filter; 5 × 10<sup>5</sup> cpm of [<sup>32</sup>P]cRNA (3 × 10<sup>7</sup> cpm/μg) in 250 μl were applied to the filter. Exposure time = 4 hr. (C) A 1:1 mixture of [ColE1]<sup>+</sup> and [ColE1]<sup>-</sup> bacteria was spread on a 47-mm filter to obtain a total of 93 colonies, of which 52 gave the A<sup>+</sup> response seen in the figure; 1 × 10<sup>6</sup> cpm of [<sup>3</sup>H]cRNA (2 × 10<sup>7</sup> cpm/μg) in 200 μl were applied to the filter. Exposure time = 24 hr.

ters. The positive response given by the [ColE1]<sup>+</sup> colonies is abbreviated by A<sup>+</sup> and the negative response of [ColE1]<sup>-</sup> colonies by A<sup>-</sup>. Colonies obtained by spreading mixtures of [ColE1]<sup>+</sup> and [ColE1]<sup>-</sup> bacteria in different ratios gave the expected frequencies of A<sup>+</sup> and A<sup>-</sup> responses. Fig. 2B shows the result obtained when [ColE1]<sup>+</sup>/[ColE1]<sup>-</sup> = 1/100.

A more precise measure of the specificity of colony hybridization of mixtures is given by the following experiment in which a 1:1 mixture of [ColE1]<sup>+</sup> and [ColE1]<sup>-</sup> bacteria was spread on a filter to yield 31 colonies. Hybridization and autoradiography revealed that 16 were A<sup>+</sup> and 15 A<sup>-</sup>. Bac-

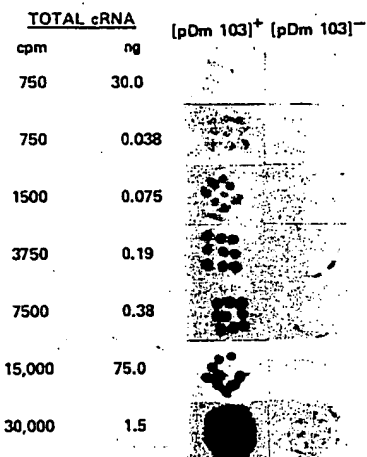

FIG. 3. Hybridization of different amounts of pDm103 [<sup>32</sup>P]cRNA to [pDm103]<sup>+</sup> and [pDm103]<sup>-</sup> colonies. Colonies were obtained by transferring HE101 [pDm103] or HB101 bacteria, respectively, to 13-mm filters with toothpicks. In the experiments where ≤1.5 ng of cRNA were applied per filter, the specific activity = 2 × 10<sup>7</sup> cpm/μg. The lower specific activities used for the other two experiments were obtained by mixing this cRNA with unlabeled pDm103 cRNA. The weak response observed for [pDm103]<sup>-</sup> colonies could result either from *E. coli* DNA impurities in the pDm103 DNA preparations used to prepare the [<sup>32</sup>P]cRNA, or from some similarity of sequence in pDm103 and *E. coli* DNAs.

teria from each of the corresponding colonies on the agar replica plate were then tested for colicin production according to an overlay technique described by Finnegan and Willets (10). All 16 A<sup>+</sup> colonies were colicin-positive (i.e., [ColE1]<sup>+</sup>); all 15 A<sup>-</sup> colonies were colicin-negative and therefore presumed to be [ColE1]<sup>-</sup>.

Fig. 2A and B show that the position of A<sup>-</sup> colonies can be detected on the autoradiograph because of the higher background radiation from the filter itself. While this background radiation is convenient for the direct visualization of A<sup>-</sup> colonies and is not critical to the observation of the A<sup>+</sup> response obtained with cRNAs, it may become an important factor with other RNAs if they give a weaker A<sup>+</sup> response. Our observations indicate that the level of this background varies with the preparation of labeled RNA and, possibly, with the batch of filters, but we have not examined such factors in detail.

Fig. 2C shows that the colony hybridization procedure can be adapted to <sup>3</sup>H-labeled cRNA by impregnating the filter with 2,5-diphenyloxazole after hybridization and prior to placement on the x-ray film (*Materials and Methods*). Of the 93 colonies obtained by spreading a 1:1 mixture of [ColE1]<sup>+</sup> and [ColE1]<sup>-</sup> bacteria, 52 were A<sup>+</sup> and 41 A<sup>-</sup>. We estimate from the extent of the A<sup>+</sup> response that this <sup>3</sup>H-fluorography is about one-twentieth as efficient as the <sup>32</sup>P-autoradiography.

The autoradiographic response is proportional to the total radioactivity of the applied cRNA and insensitive to its specific activity

We next examined the dependence of the A<sup>+</sup> response on the total and the specific radioactivity of the applied cRNA. In this case, the <sup>32</sup>P-labeled cRNA was transcribed *in vitro* from a hybrid plasmid called pDm103, and hybridized to DNA-prints of colonies that either contained this hybrid, [pDm103]<sup>+</sup>, or did not, [pDm103]<sup>-</sup>. The pDm103 hybrid was formed between pSC101 plasmid DNA (9 kb) and a segment of *D. melanogaster* DNA (Dm103; 17 kb) that contains the gene for '18' and '28S' rRNAs (3).

Fig. 3 shows that the autoradiographic response obtained when pDm103 [<sup>32</sup>P]cDNA was hybridized to 13-mm filters containing [pDm103]<sup>+</sup> colonies is roughly proportional to the total radioactivity. It is clearly insensitive to the mass of cRNA containing that radioactivity, i.e., to its specific activity. For example, the response to 750 cpm of [<sup>32</sup>P]cRNA is approximately the same whether contained in 0.038 ng or in 30 ng. Similarly the response to 15,000 cpm contained in 75 ng is intermediate between that to 7,500 cpm and 30,000 cpm, although the last two samples contained only 0.38 and 1.5 ng, respectively. This would suggest that the RNA-DNA hybridization is occurring under conditions of DNA excess even when 75 ng of pDm103 cRNA are applied per 13 mm filter. However, we have calculated that there is only some 2 ng of pDm103 DNA per colony (i.e., (2 × 10<sup>7</sup> cells per colony) × (4 pDm103 per cell) 2.9 × 10<sup>-8</sup> ng DNA per pDm103). This value is based on our observation of 2 × 10<sup>7</sup> cells per 1 mm colony and the presence of 4 pDm103 per cell in liquid culture (3). Evidently only a small fraction of the applied cRNA can react with the DNA-prints on the filter even though the reaction is occurring ostensibly in DNA excess. A similar result was observed when ColE1 cRNA was hybridized to [ColE1]<sup>+</sup> colonies (legend, Fig 2A). Of 2 ng cRNA applied to each filter only 0.004 ng (i.e., 0.2%) hybridized per [ColE1]<sup>+</sup> colony. A 1 mm [ColE1]<sup>+</sup> colony is estimated to contain 3-4 ng of ColE1 DNA.



A simple explanation of these results is obtained if one assumes that most or all of the cRNA in the small fraction of the RNA solution which wets a DNA-print will hybridize, and that the remainder of the cRNA will not hybridize at a significant rate, due perhaps to its slow diffusion through the nitrocellulose, or because of other barriers. Thus a DNA-print from a 1-mm colony, which occupies 0.6% of the area of a 13-mm filter, would be expected to hybridize  $\leq 0.6\%$  of the applied RNA, an expectation that is compatible with the 0.2% observed. For a given ratio of colony to filter area, the fraction of applied cRNA that hybridizes to a DNA-print, in conditions of local DNA excess, would therefore be constant and independent of the total applied cRNA over a wide range of values.

#### Colony hybridization with cRNA to pDm103 provides a screen for cDm plasmids containing *D. melanogaster* rDNA

Hybrid plasmids consisting of a Dm segment inserted into ColE1 DNA are called cDm plasmids, as distinguished from pDm plasmids where the Dm segment has been inserted into pSC101. In this section we describe two applications of colony hybridization that result in the isolation of cDm plasmids that contain DNA from the repeating gene-spacer units for '18-28'S rRNAs (i.e., rDNA) in *D. melanogaster* (3). In the first application, [ $^{32}$ P]cRNA to pDm103 was used to isolate clones of cDm103 plasmids; i.e., plasmids in which the Dm103 segment is inserted into ColE1 DNA at its single *Eco*RI endonuclease cleavage site (7). In the second application, the same [ $^{32}$ P]cRNA was used to screen a large set of random cDm clones for rDNA. cRNA formed by transcription of the entire pDm103 DNA can be used for these purposes since we have demonstrated that pSC101 and ColE1 sequences do not interact to give a significant A<sup>+</sup> response (data not shown).

Cleavage of circular pDm103 DNA with the *Eco*RI restriction endonuclease yields intact Dm103 segments and linear pSC101 DNA (3). In cooperation with D. M. Glover, we treated a mixture of *Eco*RI-cleaved pDm103 and ColE1 DNAs with *E. coli* ligase under previously described conditions (3), and then transformed colicin E1 immunity with this mixture of ligated DNAs (11). Since the *Eco*RI termini of the linear ColE1, pSC101, and Dm103 molecules can be randomly joined by the ligase, any of the following circular products of this ligation may be present in the colonies of transformants: (i) recycled ColE1 (monomers, dimers, etc), (ii) molecules containing one ColE1 and one pSC101 segment [abbreviated by (c)<sub>1</sub>(p)<sub>1</sub>], (iii) (c)<sub>1</sub>(Dm103)<sub>1</sub> molecules, i.e., the desired cDm103 plasmids, or (iv) rarer more complex combinations, such as (c)<sub>1</sub>(p)<sub>1</sub>(Dm103)<sub>1</sub>, which contain one or more copies of ColE1.

Forty-eight of the transformants were screened for the presence of either pSC101 or Dm103 segments by colony hybridization with [ $^{32}$ P]cRNA to pDm103 (Fig. 4A), and for the presence of the pSC101 segment by testing for resistance to tetracycline. Of the eight A<sup>+</sup> transformants shown in Fig. 4A, six were tetracycline resistant and probably contain (c)<sub>1</sub>(p)<sub>1</sub> plasmids. They were not examined further. The remaining two (indicated by 1 and 2 in Fig. 4A) were tetracycline sensitive, and were assumed to contain cDm103 plasmids; they were designated cDm103/1 and cDm103/2, respectively.

Proof of this assumption was obtained by electron microscopic examination of the plasmids isolated from the two

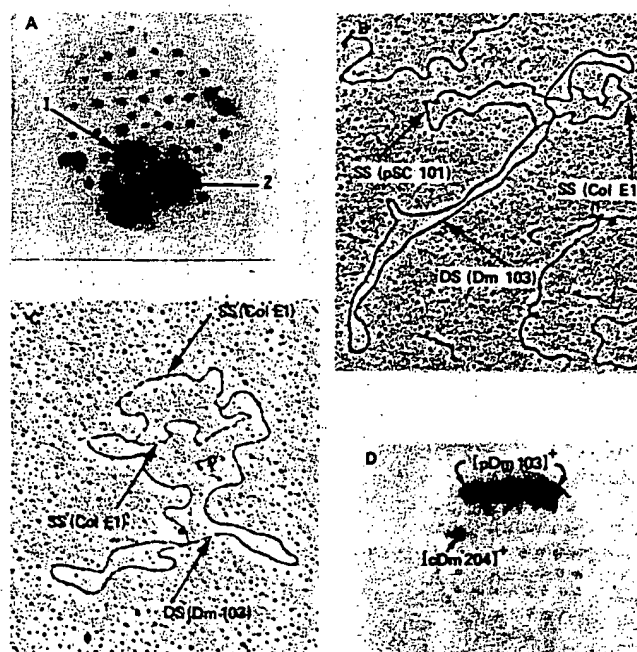

FIG. 4. (A) The screen for cDm103 hybrids. 5  $\mu$ g of pDm103 DNA and 0.25  $\mu$ g of ColE1 DNA were cleaved to completion with *Eco*RI endonuclease (in 0.120 ml of 0.1 M Tris-HCl, pH 7.5, 0.01 M MgSO<sub>4</sub>), heated for 5 min at 65° to inactivate the enzyme and brought to 4°. The DNAs were then incubated at 14° with DNA ligase (14  $\mu$ g/ml) in 0.1 M Tris-HCl, pH 7.5, as well as a reaction buffer consisting of 0.1 mM DPN, 1 mM EDTA, 10 mM (NH<sub>4</sub>)<sub>2</sub>SO<sub>4</sub>, 10 mM MgSO<sub>4</sub> with 100  $\mu$ g/ml of bovine serum albumin for 120 min in a total volume of 0.140 ml. The solution was then diluted 3-fold with the same reaction buffer and incubated for 36 hr at 14° in the presence of ligase (10  $\mu$ g/ml). The ligated mixture of *Eco*RI-cleaved pDm103 and ColE1 DNAs (see text) was used to transform HB101 to colicin E1 immunity as described previously (11). Each of 48 transformants were transferred by toothpick to a 47-mm filter for colony hybridization (*Materials and Methods*), and to L-agar plates containing 15  $\mu$ g of tetracycline per ml. 5  $\times 10^5$  cpm of pDm103 [ $^{32}$ P]cRNA (2  $\times 10^7$  cpm/ $\mu$ g) were used for the colony hybridization, which after a 6-hr exposure yielded the above autoradiograph. The colonies marked 1 and 2 contain cDm103/1 and cDm103/2 hybrids, respectively. (B) Electron micrograph of a pDm103-cDm103/2 heteroduplex. pDm103 and cDm103/2 circular DNAs were randomly nicked (broken in one strand) by x-rays. The procedures for denaturation and renaturation of these DNAs to form heteroduplexes, for spreading in 40% formamide prior to electron microscopy, and for measuring contour lengths have been described (1). pSC101 (9.2 kb; ref. 1) was used as an internal reference for double-stranded lengths (DS in the figure); no reference was used for single-stranded lengths (SS), as only the ratio of two SS-lengths is used in the analysis (see text). (C) Electron micrograph of a cDm103/1-cDm103/2 heteroduplex. The procedures are given in (B) above. See text for explanation. (D) The screen for cDm hybrids containing *D. melanogaster* rDNA. Hybrids between *Eco*RI-cut ColE1 and randomly broken Dm segments were formed as indicated in the text, and then used to transform HB101 to colicin E1 immunity as in (A) above. 300 independent transformants were transferred to six 47-mm filters, each of which contained six control colonies of HB101 [pDm103] at the top of the pattern. 5  $\times 10^5$  cpm of pDm103 [ $^{32}$ P]cRNA (2  $\times 10^7$  cpm/ $\mu$ g) was applied per filter for the colony hybridization. The autoradiograph in the figure resulted from one of the six filters after a 5-hr exposure, and shows one of the five rDNA hybrids (cDm204) identified by this screening procedure.

transformants, and of heteroduplexes formed between pDm103 and cDm103/2, and between cDm103/1 and cDm103/2. The mean lengths  $\pm$ SD ( $n = 18$ ) of cDm103/1 and cDm103/2 are 23.0 ( $\pm 1.2$ ) kb and 21.7 ( $\pm 1.5$ ) kb, respectively. The sum of the lengths of Dm103 (17 kb) and

ColE1 (6 kb; ref. 7) is 23 kb, in reasonable agreement with these values.

A heteroduplex formed between pDm103 and cDm103/2 is shown in Fig. 4B. It consists of a 17 kb double-stranded element whose ends are connected by each of two single-stranded elements that exhibit a length ratio of 1.5. This is the structure expected if cDm103/2 consists of a Dm103 segment inserted at the *Eco*RI cleavage site of ColE1; i.e., the double-stranded element represents the paired Dm103 segments of the two plasmid strands, and the larger and smaller single-stranded elements represent the pSC101 and ColE1 segments respectively (expected length ratio = 9 kb/6 kb = 1.5).

The heteroduplex formed between cDm103/1 and cDm103/2 consists of a 17 kb duplex whose ends are connected by two single-stranded elements of equal length (Fig. 4C). The simplest explanation of this structure is that the Dm103 segments were oppositely inserted into ColE1 during formation of cDm103/1 and cDm103/2. If the Dm103 segments in the single strands of two such oppositely oriented plasmids pair to create a 17 kb duplex element, then the two single-stranded ColE1 segments would contain identical rather than complementary base sequences, and could not pair.

The last experiment consists in screening hundreds of different [cDm]<sup>+</sup> colonies for rDNA. The [cDm]<sup>+</sup> colonies were obtained by transformation of colicin-sensitive *E. coli* to immunity with a heterogeneous population of cDm molecules constructed from *Eco*RI-cleaved ColE1 and random Dm segments (obtained by shear breakage) by the poly(dA)-poly(dT) joining method (1). These transformants were provided by D. J. Finnegan and G. Rubin. They were individually transferred by toothpick to six 47-mm nitrocellulose filters, each filter containing about 50 independent transformants. Colony hybridization with pDm103 [<sup>32</sup>P]cRNA indicated no A<sup>+</sup> colonies on three filters, 1 A<sup>+</sup> colony on two filters, and 3 A<sup>+</sup> colonies on one filter. The autoradiograph of one of the two filters containing a single A<sup>+</sup> colony, cDm204, is given in Fig. 4D (the top row of A<sup>+</sup> colonies on the filter are [pDm103]<sup>+</sup> controls). When each of the 5 A<sup>+</sup> colonies was retested by repeating this colony hybridization on subclones, such subclones were consistently A<sup>+</sup>.

Since pSC101 and ColE1 sequences do not interact to give an A<sup>+</sup> response, we presume that the cDm plasmids in these 5 A<sup>+</sup> colonies contain sequences present in Dm103; i.e., they contain rDNA from *D. melanogaster*. Indeed, D. M. Glover and R. L. White (personal communication) have shown recently that the 28 kb Dm segment in cDm204 contains the same arrangement of '18'-'28'S and spacer sequences as is found in Dm103.

## DISCUSSION

In principle, colony hybridization of cloned hybrid plasmids can be used to isolate any gene, or other DNA segment, whose base sequence is represented in an available RNA. We used cRNA to pDm103 for the isolation of cDm plasmids containing rDNA. However, as we have observed that [pDm103]<sup>+</sup> colonies give an adequate A<sup>+</sup> response with <sup>3</sup>H-

labeled '18' plus '28'S rRNAs isolated from *D. melanogaster* cell cultures (3), the isolation could have been accomplished with these rRNAs. For rRNA the genes are repeated hundreds of times per genome, and this is the reason that we were able to isolate several hybrids containing rDNA by screening only a few hundred colonies.

By contrast, we calculate that it would be necessary to screen approximately 50,000 hybrid clones to have a 95% chance of finding a hybrid containing a nonrepeated structural gene of typical length from *D. melanogaster*. From the data given in Fig. 3 and assuming 24-hr exposures, we estimate that this would require a total of approximately 4 × 10<sup>6</sup> cpm of [<sup>32</sup>P]mRNA (specific activity ≥ 4 × 10<sup>5</sup> cpm/μg) applied to about one hundred thirty-five 82-mm filters. Thus a screen of this size is quite feasible. The isolation of nonrepeated genes from larger genomes would, of course, proportionately increase the number of colonies to be screened and hence the total required radioactivity.

An important advantage of colony hybridization is that it facilitates containment of any potentially hazardous hybrid plasmids that may be cloned in such large screening operations. By confining the reproductive state of the hybrid-clones to colonies, the probability of escape is reduced over that for liquid cultures because the number of bacteria per clone is generally smaller and aerosols or accidental spills are less likely. Furthermore the screening operation can be confined to small, controllable areas.

M.C. is grateful to R. T. Schimke for his support and encouragement. We thank D. J. Finnegan, D. M. Glover, G. M. Rubin, and R. L. White for helpful discussions and for providing materials. We are especially thankful to D. M. Glover for his help and advice in isolating and characterizing the cDm103 hybrids. This work was supported by grants from the National Science Foundation (BMS74-21774) and the National Institutes of Health (GM20158, GM14931).

1. Wensink, P. C., Finnegan, D. J., Donelson, J. E. & Hogness, D. S. (1974) *Cell* 3, 315-325.
2. Hogness, D. S., Wensink, P. C., Glover, D. M., White, R. L., Finnegan, D. J. & Donelson, J. E. (1975) in *The Eukaryote Chromosome*, eds. Peacock, W. J. & Brock, R. D. (Australian National University Press, Canberra), in press.
3. Glover, D. M., White, R. L., Finnegan, D. J. & Hogness, D. S. (1975) *Cell* 5, 149-157.
4. Hayes, W. (1965) in *The Genetics of Bacteria and Their Viruses* (John Wiley & Sons, New York), pp. 185-188.
5. Lederberg, E. M. (1960) *Symp. Soc. Gen. Microbiol.* 10, 115-131.
6. Katz, L., Kingsbury, D. K. & Helinski, D. R. (1973) *J. Bacteriol.* 114, 577-591.
7. Hershfield, V., Boyer, H. W., Yanofsky, C., Levett, M. A. & Helinski, D. R. (1974) *Proc. Nat. Acad. Sci. USA* 71, 3455-3459.
8. Berg, D., Barrett, K. & Chamberlin, M. (1971) in *Methods in Enzymology*, eds. Grossman, L. & Moldave, K. (Academic Press, New York), Vol XXI, pp. 506-519.
9. Randerath, K. (1970) *Anal. Biochem.* 34, 188-205.
10. Finnegan, D. J. & Willetts (1972) *Mol. Gen. Genet.* 119, 57-66.
11. Glover, D. (1975) in *New Techniques in Biophysics and Cell Biology*, eds. Pain, R. & Smith, B. (John Wiley & Sons, New York), in press.

## Changes in the Abundance of Polyadenylated RNA During Slime Mould Development Measured Using Cloned Molecular Hybridization Probes

J. G. WILLIAMS AND M. M. LLOYD

*Imperial Cancer Research Fund  
Burtonhole Lane, Mill Hill  
London, NW7 1AD, England*

(Received 25 August 1978, and in revised form 12 November 1978)

Total *Dictyostelium discoideum* messenger RNA prepared from cells at the eighth hour of development in suspension culture has been copied into DNA. This DNA was inserted into the plasmid PMB9 and used to transform *Escherichia coli*. The resulting "clone bank" was screened using an *in situ* hybridization technique in which replicate copies of a set of clones were hybridized with mRNA isolated from vegetative (non-developing) cells and from cells at the eighth hour of development. The mRNA was labelled *in vitro* so that the amount of hybridization to a given clone is a measure of the relative abundance of the mRNA complementary to the DNA in that clone. By comparing the amount of hybridization of the mRNA preparations to each clone, it has been possible to identify plasmids containing *D. discoideum* DNA whose complementary mRNA increases or decreases in abundance during development. These observations are direct proof of a change in mRNA concentration during *D. discoideum* development for individual high and medium abundance mRNA species. We can estimate from these results the proportion of such mRNA species whose concentration increases significantly during development and we find that only a small fraction show such a change.

### 1. Introduction

*Dictyostelium discoideum* amoebae multiply as isolated cells and development begins when their food source is exhausted. Cells aggregate by chemotaxis and undergo differentiation into two cell types (spore and stalk cells) to form a mature fruiting body, the whole process taking about 24 hours. During this developmental progression a number of new enzymes appear and there is some indirect evidence that their synthesis is controlled at the level of transcription (see Loomis, 1975). Such a sequence of gene activations, occurring in response to the signals of normal development, provides an excellent system for studying the control of gene expression in eukaryotes.

Gene organization and transcription in *D. discoideum* are similar to that found in higher eukaryotes. Though the genome is very much smaller than that of higher eukaryotes (11 times larger than *Escherichia coli*) it contains repetitive and single copy interspersed in a similar manner (Firtel *et al.*, 1976). At least the majority of messenger RNA molecules contain a 3' terminal poly(A) sequence (Firtel *et al.*, 1972) and a 5' terminal cap structure (Dottin *et al.*, 1976), both added post-transcriptionally. Estimates from RNA excess hybridization to genomic DNA (Firtel, 1972), and to

complementary DNA (Lodish *et al.*, 1978), indicate the presence of approximately 5000 different mRNA sequences in vegetative (non-developing) cells. Using RNA isolated at different developmental stages Firtel (1972) and Lodish *et al.* (1978) estimated that a further 5000 or so sequences were transcribed during development. However, Alton & Lodish (1977) have studied the patterns of proteins synthesized by cells at different developmental stages, using two-dimensional gel electrophoresis, and arrive at a much lower estimate of the number of translationally active mRNA species present during both growth and development. Genetic estimates of the number of genes required for development are also much lower than 5000 (Warren *et al.*, 1975; Williams & Newell, 1976).

The above studies used total messenger and nuclear RNA populations containing many different sequences. Further advance requires the preparation of hybridization probes specific for individual mRNA species. However, the mRNA species coding for developmentally regulated enzymes might be expected to constitute only a very small proportion of the mRNA population and to purify such an mRNA, in order to make a hybridization probe, would be very difficult using standard mRNA purification techniques. We have adopted an alternative strategy in which gene cloning is used as the first step in the procedure, since this provides an absolute purification of individual mRNA species. Thus we have prepared a "cDNA† clone bank" containing the majority of different polyadenylated (poly(A)+) RNA sequences present at the eighth hour of development. Using a semi-quantitative *in situ* hybridization technique we have selected several clones whose complementary RNA sequences show the kind of behaviour which might be expected of an mRNA coding for a developmentally regulated enzyme. The RNA species hybridizing to the DNA in these clones are present at low (but measurable) levels in developmental cells but are absent (or present at an undetectably low level) in vegetative cells. The fact that such clones could be identified is in itself a significant observation, since it proves that there are changes in concentration of individual poly(A)+ RNA species during development. We can also make an approximate estimate from our results of the fraction of high and medium abundance poly(A)+ RNA species whose concentration is developmentally regulated, and our estimate is in reasonable agreement with the estimated fraction of proteins which are developmentally regulated (Alton & Lodish, 1977).

## 2. Materials and Methods

### (a) Cell culture and fractionation

*D. discoideum* strain Ax 2 (ATCC 24397 from J. Ashworth) was recovered from spores every few months and grown in axenic medium (Watts & Ashworth, 1970) containing 100 µg streptomycin/ml. Development was initiated by 2 washes with 20 mM-potassium phosphate buffer (pH 6.1 to pH 6.2) containing 2 mM-magnesium sulphate and resuspension in the same buffer at 10<sup>7</sup> cells/ml in a conical flask shaken at 120 revs/min. Development was routinely monitored by performing assays for the enzymes cyclic AMP phosphodiesterase (Henderson, 1975) and glycogen phosphorylase (Town & Gross, 1978). At the latest stages of development analyzed in this study (10 h) the cAMP phosphodiesterase level was falling, glycogen phosphorylase synthesis had begun (see Fig. 2(a)) and the cells had formed very large aggregates. Thus the cells are at, what would be, the post-aggregative stage of development were they developing on agar plates. Cells were fractionated into nucleus and cytoplasm using the procedure described by Jacobson (1976) but including 0.5% diethyl pyrocarbonate in the lysis buffer.

† Abbreviations used: cDNA, complementary DNA; cRNA, complementary RNA.

## (b) Purification and labelling of polyadenylated RNA

After phenol/chloroform extraction, polyadenylated RNA was prepared by oligo(dT)-cellulose chromatography. Two cycles of binding and elution were routinely performed and this yielded an mRNA preparation with around 50% ribosomal RNA contamination. Size analysis on 1% agarose gels containing methyl mercury hydroxide (Bailey & Davidson, 1976), and [<sup>3</sup>H]poly(U) hybridization across a sucrose gradient, both indicated an average size of around 15,000 nucleotides. Poly(A)+ RNA to be end-labelled with <sup>32</sup>P was base-cleaved with 0.1 M-NaOH for 1 h at 4°C to yield fragments of around 200 nucleotides in length. After neutralization and precipitation with ethanol RNA was resuspended at 50 µg/ml and incubated with 50 units of T4 polynucleotide kinase/ml (a gift of Dr G. Banks) in a buffer containing 50 mM-Tris (pH 7.6), 5 mM-magnesium chloride, 10 mM-mercaptoethanol and 100 µCi of (γ-<sup>32</sup>P)-labelled ATP/ml (Radiochemical Centre, Amersham; spec. act. up to 5000 Ci/mmol). This reaction mix was incubated for 30 min at 37°C and the labelled RNA was phenolized, passed over a Sephadex G50 column and concentrated by precipitation with ethanol. RNA labelled by this technique normally had a spec. act. of about 5 × 10<sup>7</sup> cts/min per µg and in optimal cases up to 50% of the input label could be incorporated into RNA. The RNA had an average size of around 100 nucleotides and proved to be as efficient in hybridization as [<sup>3</sup>H]cRNA (prepared against PMB9 plasmid) of around 400 nucleotides in length.

## (c) Cloning of complementary DNA

## (i) Synthesis of complementary DNA

Fifty µg of poly(A)+ RNA prepared from cells at the 8th hour of development were used to synthesize cDNA in a 1.1-ml reaction mix containing 50 mM-Tris (pH 8.3), 60 mM-sodium chloride, 10 mM-dithiothreitol, 6 mM-magnesium acetate, 0.5 mM-dATP, 0.5 mM-dGTP, 0.5 mM-dTTP, 0.5 mM-[<sup>3</sup>H]dCTP (spec. act. 200 Ci/mmol) and 5 µg oligo(dT)<sub>14</sub>/ml. The reaction was initiated by the addition of avian myeloblastosis virus (AMV) reverse transcriptase (a gift of Dr J Beard) to a final concn of 200 units/ml and the reaction was terminated after 1 h at 37°C by the addition of sodium dodecyl sulphate to 0.5%. The entire reaction mix was then passed over Sephadex G50 in sodium dodecyl sulphate-containing buffer and the excluded material was concentrated by precipitation with ethanol and resuspended in 200 µl of water. RNA was removed by incubation in 0.3 M-NaOH for 2 h at 37°C and the final yield of cDNA was 6.25 µg (12.5% weight yield).

## (ii) Synthesis of a complementary strand and cleavage of the hairpin loop

In an attempt to optimize the fraction of single-stranded cDNA copies of several different conditions of second strand synthesis were compared. Using AMV reverse transcriptase (at both 37°C and 45°C) under the low salt conditions described by Monahan *et al.* (1976) only 20% of input cDNA could be rendered resistant to S<sub>1</sub> nuclease. Using T4 polymerase 63% of the cDNA was rendered S<sub>1</sub> nuclease-resistant. This yield is comparable with that obtained for purified mRNA species such as globin (Rougeon & Mach, 1976) or ovalbumin (Monahan *et al.*, 1976). This reaction was performed with 6 µg of cDNA which was incubated with T4 DNA polymerase (a gift of Dr I. Molineux) in a 90-µl reaction identical to the reverse transcriptase mix except that unlabelled dCTP (again 0.5 mM) was used and salt was omitted. The reaction was performed at 37°C and 0.5 µl portions were removed at various times during the incubation to determine the fractional S<sub>1</sub> nuclease resistance. At the end of the reaction the entire reaction was diluted to a final vol. of 1 ml in S<sub>1</sub> nuclease digestion buffer prepared according to Schenk *et al.* (1975) and containing 2 × 10<sup>4</sup> units of S<sub>1</sub> nuclease (Miles Research Products Ltd). After 30 min at 25°C the sample was phenolized and passed over a Sephadex G50 column in TE buffer (10 mM-Tris, pH 8.0, 1 mM-EDTA). Under these conditions 50% of molecules were cleaved, as monitored by determining the fraction of molecules which displayed zero-order (snapback) kinetics. The same amount of cleavage occurred when enzyme from several sources was used and also when the temperature was raised from 25°C to 37°C. Since similar observations have been made for globin mRNA (Salser *et al.*, 1976) it is probable that no selected class of RNAs was lost by this incomplete cleavage.

(iii) *Addition of poly(dG) to the double-stranded complementary DNA and insertion into PMB9 plasmid*

A tract of poly(dG) was added to the double-stranded cDNA using terminal deoxy nucleotidyl transferase (gift of Dr J. Colbourn of Miles Research Products Ltd) in a cobalt activated reaction (Roychoudry *et al.*, 1976) with bovine serum albumin (Miles Pentex) added to 50  $\mu\text{g/ml}$ . The final reaction vol. was 0.5 ml and the reaction contained 0.6  $\mu\text{g}$  of double-stranded cDNA and 70 units of enzyme. After 30 min the level of incorporation of [ $^3\text{H}$ ]dGTP (present at a concn of 0.1 mM and a spec. act. of 900 cts/min per pmol) indicated the addition of about 50 dG residues per 3' terminus (calculated assuming an average length for the DNA of 500 nucleotides). The sample was then extracted with phenol, passed over a Sephadex G50 column in TEN buffer (10 mM-Tris, pH 8.0, 1 mM-EDTA, 200 mM-NaCl) and stored at 4°C. (Alkali sucrose gradient centrifugation indicated an average single-strand size of around 500 nucleotides for the tailed cDNA.) Caesium chloride-purified PMB9 plasmid was cleaved with *EcoRI* (a gift of Dr J. Arrand) and tailed plasmid DNA (final concn 0.5  $\mu\text{g/ml}$ ) were annealed in TEN buffer at 60°C for 2 h and the water bath was then allowed to cool to room temperature over a period of roughly 4 h. *E. coli* strain Hb101 (Boyer & Roulland-Dussoix, 1969) was rendered transformation competent by treatment with 80 mM- $\text{CaCl}_2$  and transformed with the annealed DNA. Cells were plated on L agar (Miller, 1972) containing 15  $\mu\text{g}$  tetracycline/ml. Under these conditions supercoil plasmid has a transformation frequency of  $1 \times 10^6$   $\mu\text{g}$ , dC tailed plasmid alone a frequency of  $1 \times 10^2$   $\mu\text{g}$ , and plasmid annealed to cDNA a frequency of  $2 \times 10^4$   $\mu\text{g}$ . Transformed clones were tooth-picked into 0.1 ml of L broth (containing 15  $\mu\text{g}$  tetracycline/ml) in the wells of micro-titre trays, incubated at 37°C overnight and frozen at -70°C after the addition of 0.1 ml. of 16% dimethylsulphoxide in L broth.

(d) *In situ hybridization to bacterial colonies*

Micro-titre trays were thawed at 37°C and replica cultures were made directly onto nitrocellulose filters (Millipore; HAWP 9 cm filters) lying on L agar plates (50 clones were transferred simultaneously using a replica plating device). These plates were incubated overnight at 37°C and the filters were then processed by a simplified version of the Grunstein & Hogness (1975) procedure using wetted 3 MM paper for alkali denaturation and neutralization. After baking at 80°C for 2 h, filters were placed face down in 9 cm tissue culture dishes containing 8 ml of hybridization buffer (100 mM-*N*-Tris(hydroxymethyl) methyl amino ethane sulphonic acid (TES), pH 7.4, 0.6 M-NaCl, 1 mM-EDTA, 0.1% sodium dodecyl sulphate, 25  $\mu\text{g}$  yeast transfer RNA/ml and 50% formamide) with the required amount of end-labelled RNA (normally  $10 \times 10^6$  cts/min). After 16 h incubation at 37°C, filters were washed individually in 1-l beakers gently shaken at 37°C. Filters were washed 4 times, in 200 ml of  $2 \times \text{SSC}$  (SSC is 0.15 M-NaCl, 0.15 M-sodium citrate, pH 7.0), 50% formamide for 1 h, twice in 200 ml of  $2 \times \text{SSC}$  for 30 min, blotted dry and then placed under clear plastic film and exposed to X-ray film. Films were exposed at -70°C using a Fuji calcium tungstate intensifying screen (Laskey & Miller, 1977), for periods of up to 2 weeks.

(e) *Hybridization to filter-bound DNA*

Plasmid prepared by caesium chloride/ethidium bromide centrifugation was briefly sonicated, denatured with alkali and bound to 2.5 cm nitrocellulose filters (Millipore; HAWP 02500). Normally 20  $\mu\text{g}$  was bound to one filter which was then cut into quarters. Up to 8 such filter sections from different DNA preparations were placed in small vials with the hybridization buffer described above, and the vials were incubated for 16 h at 37°C on a roller drum machine. Under these conditions efficiency of hybridization was about 33%. After hybridization the filters were washed in the same way as the Grunstein-Hogness filters and baked dry. They were counted after solubilization in a toluene scintillant containing methoxyethanol.

## DNA and insertion into

## (f) Containment procedures

These experiments were performed in a category II containment laboratory as defined by the Williams report.

## 3. Results

## (a) Cloning of the total poly(A) + RNA population from slime mould cells at the eighth hour of development

The aim of these experiments was to isolate cloned plasmids containing poly(A) + RNA sequences present at very low concentration in a heterogeneous population. It was important that the cDNA cloning be as efficient as possible, otherwise the final cDNA "clone bank" might not contain sequences derived from all the RNA species in the population. We therefore used a procedure (see Materials and Methods) which gave yields of double-stranded DNA and cleavage of the hairpin loop comparable with that obtained for purified mRNA species such as globin (Salser *et al.*, 1976) or ovalbumin (Monahan *et al.*, 1976). This cleaved double-stranded DNA was then "tailed" with poly(dG) using terminal deoxynucleotidyl transferase, annealed with poly(dC) tailed PMB9 plasmid and used to transform the *E. coli* strain Hb101 to produce a cDNA clone bank.

## (b) Selection of complementary DNA clones with detectable hybridization to eight-hour developmental poly(A) + RNA and elimination of "ribosomal" complementary DNA clones

We screened our clones using the *in situ* hybridization technique of Grunstein & Hogness (1975). The aim of these experiments was to detect hybridization between cloned DNA and complementary poly(A) + RNA sequences present at a very low concentration in the RNA population. Therefore the background level of hybridization had to be made as low as possible and several modifications of the published procedure were developed which proved essential in reducing the apparent hybridization to PMB9 control clones included on the filter.

- (1) The stringency of the filter washing procedure was increased by reducing the salt concentration from 0.9 M to 0.36 M.
- (2) Hybridization under paraffin was found to lead to high, irregular, backgrounds over the colonies. Several other procedures were tried, and of these, immersing the filters face down in a large volume of hybridization buffer proved to be the best. Although dilution of the label into a large volume reduced the number of counts available for hybridization it gave a much lower and more reproducible background.

The level of detection in these hybridizations was estimated by including several different control bacterial clones containing segments of genomic *D. discoideum* DNA which hybridized to a known fraction of the poly(A) + RNA population (Williams, unpublished work). While there was some variability from experiment to experiment, we estimated that in optimal cases, such as the hybridization shown in Figure 1, a clone hybridizing to around 0.1% of the RNA population could be detected.

Previous experience indicated that a fraction of the cDNA clones prepared in this way would contain segments of cDNA too short to form a stable hybrid. Also of course,

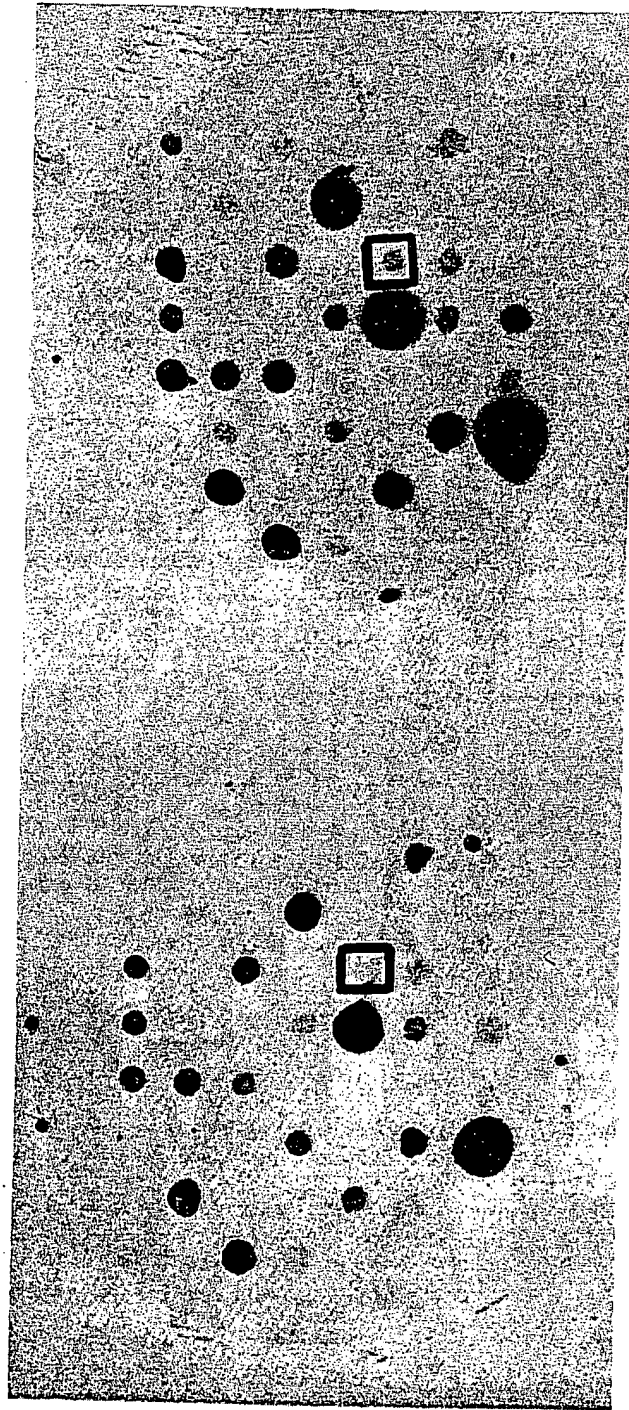

FIG. 1. Comparison of the hybridization of 50 cDNA clones with 8-h developmental poly(A)+ RNA and with vegetative poly(A)+ RNA.

This autoradiogram is part of the screen of 250 clones which had previously been selected as showing detectable hybridization with 8-h developmental poly(A)+ RNA. Fifty clones were transferred to each of the 2 filters using a replica plating device and, after alkali denaturation and neutralization as described in Materials and Methods, the filters were hybridized with  $5 \times 10^6$  cts/min of 8-h developmental poly(A)+ RNA (upper panel) and  $5 \times 10^6$  cts/min of vegetative cell poly(A)+ RNA (lower panel). Exposure was for 2 weeks at  $-70^\circ\text{C}$  with an intensification screen. The clone in the indicated square is designated 11/7/10 and its further characterization is described in the text.

N.B. Of the 250 clones screened in this experiment only 130 clones showed hybridization above background because after the first screen (with 8-h developmental poly(A)+ RNA) we included clones with an apparent hybridization very near background in order not to discard, unnecessarily, clones with a low level of hybridization.

som  
dete  
cDN  
eigh  
usec  
A  
sele  
this  
& H  
RN.  
asso  
men  
otic  
of sq  
Se  
ribo:  
genc  
since  
izati  
Thei  
was  
Only  
ated  
pres:  
the r

(c)

Th  
filter  
with  
two  
men  
Part  
of 50  
clone  
conc  
posit  
grou  
furth  
23 h  
and  
clone

Ar  
in-sit



some poly(A)+ RNA species are present in the RNA population at levels too low to detect, even with this modified technique. Therefore the first step in screening the cDNA clones was to select clones which showed detectable hybridization with the eighth hour developmental poly(A)+ RNA preparation (termed 8-h (A)+ RNA) used for cloning.

A total of 1200 clones were screened with 8-h (A)+ RNA and of these 250 were selected as having significant amounts of hybridization. Hybridization performed in this way is a DNA excess hybridization in the local area of any one colony (Grunstein & Hogness, 1975). Since the RNA is labelled by an *in vitro*-labelling technique, and all RNA sequences are therefore presumably equally labelled, the amount of radioactivity associated with each clone is a measure of the fraction of the RNA population complementary to the DNA in that clone. Because the poly(A)+ RNA sequences in a eukaryotic cell are present at widely divergent abundances (Bishop *et al.*, 1974) the pattern of spots observed on the autoradiogram shows a spectrum of intensities.

Several of the clones showed as much hybridization as a control clone containing ribosomal DNA which was included on the filter. (This is a clone derived from sheared genomic DNA (Williams, unpublished work).) This was an unexpected observation, since ribosomal RNA constitutes around 50% by weight of the RNA used for hybridization and obviously no single poly(A)+ RNA could be present at such a level. Therefore the 250 clones were screened again using total "poly(A)minus" RNA (this was the oligo(dT)-cellulose "flowthrough" of the RNA preparation used for cloning). Only the four clones showing very strong hybridization with eight-hour polyadenylated RNA showed hybridization with this poly(A)minus RNA. These clones are presumably "ribosomal cDNA" clones resulting from reverse transcriptase copying of the ribosomal RNA contaminating the RNA population used for cloning.

(c) *Comparison of hybridization of the complementary DNA clones with vegetative and developmental messenger RNA*

The 250 positive clones from the first screen were replicated onto two sets of Millipore filters. One set was hybridized with vegetative (termed 0-h) (A)+ RNA and the other with 8-h (A)+ RNA. By comparing the hybridization of each clone with each of these two RNA populations it proved possible to identify clones containing DNA complementary to poly(A)+ RNA species whose concentration changed during development. Part of such a screen is shown in Figure 1. The upper panel shows the hybridization of 50 clones with 8-h (A)+ RNA, and the lower panel hybridization of the same 50 clones with 0-h (A)+ RNA. A typical example of a clone whose RNA increased in concentration during development is displayed in Figure 1. The colony in the marked position shows a significant level of hybridization with 8-h (A)+ RNA and only background hybridization with 0-h (A)+ RNA. (This clone is designated 11/7/10 and its further characterization is described later.) Of the 250 clones analyzed in this screen 23 hybridized to an RNA species which changed in concentration during development and these were selected for further analysis (these clones are termed developmental clones).

(d) *The analysis of developmental clones by DNA filter hybridization*

An accurate estimate of the magnitude of the developmental changes observed in the *in situ* hybridization was obtained by performing quantitative DNA filter hybridization.

developmental poly(A)+  
iously been selected as  
NA. Fifty clones were  
alkali denaturation and  
ybridized with  $5 \times 10^6$   
ybridized with  $5 \times 10^6$   
s/min of vegetative cell  
1 intensification screen.  
cterization is described.

od hybridization above  
) + RNA) we included  
discard, unnecessarily,

The 23 putative developmental clones were grown up and the total DNA from a cleared lysate of each culture was bound to a single nitrocellulose filter. Equal sections of each filter were hybridized to 0-h and 8-h (A)+ RNA. Hybridization under these conditions is a DNA excess hybridization with an efficiency of approximately 30% (see the legends to Table 1 and Fig. 2). From the amount of hybridization observed,

TABLE 1

*Quantitative DNA excess hybridization of the 23 clones selected from the in situ hybridization as showing developmental changes in poly(A)+ RNA hybridization*

Source of DNA on filter	Ratio of mRNA concentration at 8-h to that at 0-h	Source of DNA on filter	Ratio of mRNA concentration at 8-h to that at 0-h
Clone 2/7/11	> 10	Clone 8/7/10	0.31
Clone 4/3/1	0.71	Clone 9/6/4	2.1
Clone 5/2/2	> 10	Clone 9/7/5	3.1
Clone 5/3/6	2.9	Clone 9/7/10	3.6
Clone 5/8/3	> 10	Clone 10/2/2	0.51
Clone 6/2/5	1.2	Clone 10/7/3	3.8
Clone 6/6/2	1.8	Clone 10/10/1	> 10
Clone 8/1/2	> 10	Clone 11/7/10	> 10
Clone 8/2/2	> 10	Clone 12/6/8	1.7
Clone 8/3/2	< 0.1	Clone 12/6/9	> 10
Clone 8/3/7	2.5	Clone 12/6/10	0.42
Clone 8/4/3	0.49		

The total DNA yield from a cleared lysate of a chloramphenicol-amplified bacterial culture was bound to a single filter and the filter was cut into 4 quarters. One quarter was hybridized with  $1.1 \times 10^6$  cts/min of 5' terminal  $^{32}\text{P}$ -labelled vegetative (0-h) poly(A)+ RNA and one quarter with an equal amount of developmental (8-h) poly(A)+ RNA. The other 2 quarters were hybridized in separate vials with  $10^6$  cts/min of  $^3\text{H}$ RNA complementary to PMB9 (prepared as described by Grunstein & Hogness (1975) and at a spec. act. of  $10^7$  cts/min per  $\mu\text{g}$ ). The amount of hybridization to this RNA was used as a measure of the hybridization efficiency (between 25 and 35%) and the percentage of input RNA complementary to the DNA on the filter was calculated using this value (after deduction of the background binding to PMB9 DNA). Since there is a measurable background hybridization (see Fig. 2) the ratio of 8-h to 0-h poly(A)+ RNA concentration of a clone such as 5/2/2 (where after background deduction there is low or undetectable hybridization to 0-h mRNA) is described as being  $\geq 10$ .

figure for the percentage of the input RNA complementary to the DNA on the filter was obtained. This was used to calculate the ratio of RNA concentration at 8-h to that at 0-h (Table 1). This ratio varied from  $< 0.1$  to  $> 10$  for different clones. There is a very good correlation between relative abundance estimated from the *in situ* hybridization and the abundance measured directly by DNA filter hybridization, with 22 out of the 23 clones showing the expected change in abundance. This confirms the usefulness of the Grunstein-Hogness technique as a semi-quantitative method of estimating the abundance of individual RNA species in a heterogeneous population.

length of the RNA, since the plasmid containing ribosomal DNA was derived from genomic DNA and contains the entire 28 S and 18 S ribosomal RNA coding sequence. (b) and (c) The plasmid DNAs used were: upper panel: PMB9 (— $\otimes$ — $\otimes$ —); clone 5/8/3 (— $\bullet$ — $\bullet$ —); clone 10/10/1 (— $\square$ — $\square$ —); clone 11/7/10 (— $\circ$ — $\circ$ —); clone 5/2/2 (— $\times$ — $\times$ —); lower panel: clone 8/1/1 (— $\bullet$ — $\bullet$ —); clone 8/3/2 (— $\circ$ — $\circ$ —).

7D

total DNA from a cleared  
r. Equal sections of each  
zation under these con  
approximately 30% (see  
ybridization observed,

ected from the *in situ*  
+ RNA hybridization

Ratio of mRNA  
concentration at  
8-h to that at 0-h

- 0.31
- 2.1
- 3.1
- 3.6
- 0.51
- 3.8
- √ 10
- √ 10
- 1.7
- √ 10
- 0.42

olified bacterial culture was  
arter was hybridized with  
) + RNA and one quarter  
er 2 quarters were hybrid  
MB9 (prepared as described  
. The amount of hybridiza  
y (between 25 and 35%)  
er was calculated using this  
ince there is a measurable  
+ RNA concentration of a  
undetectable hybridization

the DNA on the filter  
centration at 8-h to that  
erent clones. There is a  
rom the *in situ* hybrid  
ybridization, with 22  
nce. This confirms the  
uantitative method of  
erogeneous population

derived from genomic DNA  
s. (b) and (c) The plasmid  
●—●—●); clone 10/10/  
lower panel: clone 8/1/2

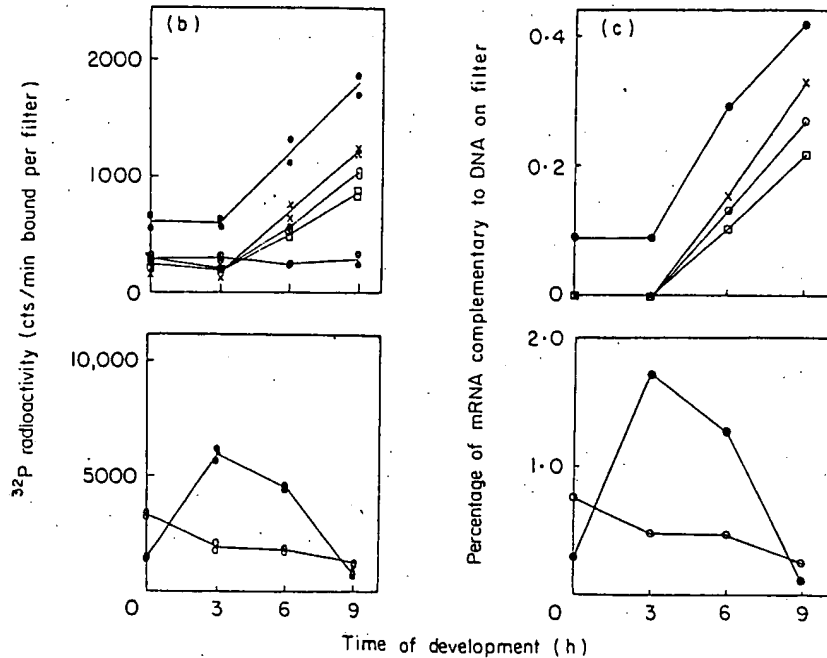
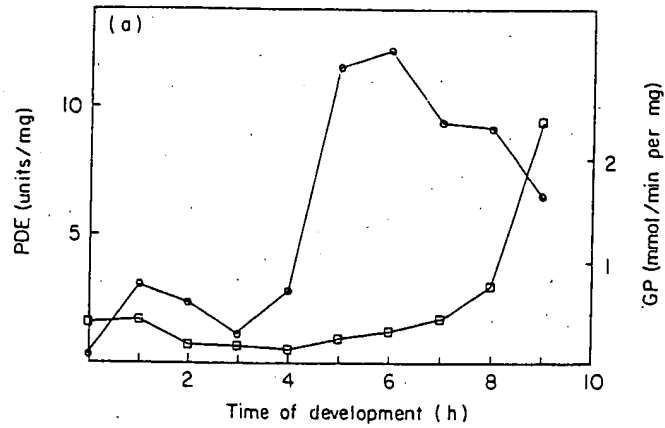

FIG. 2. Developmental time course of changes in concentration of the poly(A)+ RNA complementary to DNA isolated from selected clones.

Twenty  $\mu\text{g}$  of purified plasmid DNA was bound to each of 2 nitrocellulose filters and each filter was then cut into 4 equal sections. Duplicate sections were then hybridized in separate vials with  $2 \times 10^6$  cts/min of  $^{32}\text{P}$  end-labelled poly(A)+ RNA isolated at the indicated stages of development. The time course of development is indicated by the cAMP phosphodiesterase (PDE) (—○—○—) and glycogen phosphorylase (GP) (—□—□—) accumulation curves displayed in (a). The number of counts hybridizing to each filter is shown in (b), after deduction of a 20-cts/min "scintillation counter" background. The number of counts binding to each filter was then corrected for by deducting the number of counts binding to the filters bearing PMB9 DNA (—⊗—⊗—). Hybridization to a genomic clone containing the 28 S and 18 S ribosomal sequences (Lloyd & Williams, unpublished results) was used to correct for ribosomal RNA contamination of the RNA preparations. Control experiments with PMB9 cRNA (see Table 2) and poly(A)— RNA labelled *in vitro* with  $^{32}\text{P}$  shows that 33% of input RNA will hybridize to a filter section containing  $5 \mu\text{g}$  of DNA hybridized under these conditions. Using this normalization, the amount of ribosomal RNA contaminating the RNA was estimated (in each case around  $1 \times 10^6$  cts/min) and deducted from the  $2 \times 10^6$  cts/min input to give an estimate of the actual input of poly(A)+ RNA. This value was then used to estimate the percentage of each input poly(A)+ RNA bound to each DNA and this percentage was corrected for hybridization efficiency (again 33%) to give an estimate of the percentage of the poly(A)+ RNA complementary to each DNA. Since the RNA was fragmented into pieces of around 100 nucleotides in length, and since the cDNA inserts in these plasmids are less than full length (see text), the relative abundance of each of these poly(A)+ RNA species is somewhat higher than indicated by the fraction of input poly(A)+ RNA hybridized. This does not of course affect our estimate of the magnitude of the change in abundance during development. The measurement of ribosomal RNA contamination is also not affected by the

The developmental cloned DNAs fell into three classes.

- (1) Those hybridizing to an RNA whose concentration decreased during the first eight hours of development.
- (2) Those hybridizing to an RNA whose concentration increased from a low level in vegetative cells to a higher level in eight-hour developmental cells.
- (3) Those hybridizing to an RNA which was only detectable in eight-hour developmental cells.

The clones in the last class all hybridized to poly(A)+ RNA species present at a relatively low abundance even at eight-hours (see the legend to Fig. 2). Such RNAs show the behaviour we feel might be expected for mRNAs which code for developmental enzymes, and we concentrated our efforts on clones in this class, but we included one representative of each of the other classes.

(e) *Time course of synthesis of the RNA complementary to the DNA in selected clones of the developmental plasmids*

Purified plasmid DNA from each of the selected clones was bound to nitrocellulose filters and hybridized with poly(A)+ RNA prepared from slime mould cells at various stages of development and end-labelled as before. The data from a typical experiment are presented in both an uncorrected form and in a corrected form (Fig. 2) so that the background deductions, corrections for ribosomal RNA contamination and correction for hybridization efficiency can be clearly presented. The amount of hybridization of the three low abundance clones (5/2/2, 11/7/10, 10/10/1) with 9-h (A)+ RNA is three to four times the background level of binding to PMB9 DNA. Since the duplicate filters hybridized in separate vials are in close agreement, it is probably safe to conclude that the RNA species hybridizing to these clones are at least ten times more abundant in nine-hour cells than in vegetative cells. The other low abundance clone (5/8/3) has a measurable level of hybridization with vegetative cell RNA and there is an increase in the amount of hybridizable RNA during development. The clone whose complementary RNA was expected to drop in concentration (8/3/2) showed the expected behaviour. An interesting result was obtained with 8/1/2. The previous hybridization (Table 1) was performed only with zero-hour and eight-hour mRNA and therefore the very large peak of hybridization present at three to four hours of development was not seen until this time course was performed. In two further experiments with different poly(A)+ RNA preparations similar results were obtained with DNA from each of the above plasmids (data not shown). We also tested the other three low abundance developmental clones and plasmid DNA from two of these (8/2/2 and 12/6/9) hybridized to an RNA species which was only detectable after six hours of development. Plasmid DNA from the other clone (2/7/11) hybridized to an RNA which reached its maximal concentration at the third hour of development.

(f) *Further characterization of selected developmental complementary DNA clones*

The cloning procedure we have used did not include a size selection step because we wished to avoid performing any selection which might result in preferential loss of specific poly(A)+ sequences. The size of the "tailed" double-stranded cDNA, before insertion into the plasmid, was determined (see Materials and Methods) and the number

average molecular weight indicated an average length of approximately 500 nucleotides. However, it has proved difficult to obtain size estimates for the slime mould inserts in some of the individual cDNA clones which we have selected for further study, because of deletions around the PMB9 *Eco*RI site used for cloning (such deletions have been observed previously, e.g. Humphries *et al.*, 1977). We have been able to obtain a length estimate for some of our selected plasmids by determining the length of the largest *Hae*III fragment, which in PMB9 contains the *Eco*RI site used for cloning (Fig. 3). Thus clone 8/1/2 contains an insert which increases the length of the largest *Hae*III fragment by 570 nucleotides. Since the average length of the dG·dC linkers is estimated to be approximately 50 nucleotides we are confident that a reasonably large portion of this particular poly(A)+ RNA has been cloned (if the PMB9 DNA around this particular insert has been deleted this will of course be an underestimate of the size of the cloned fragment). In the case of clone 11/7/10 we have very strong evidence for a substantial insert, since the largest *Hae*III fragment in PMB9 has been replaced by two *Hae*III fragments with a combined size which is 890 nucleotides longer than the equivalent fragment in PMB9. We also know that there is an

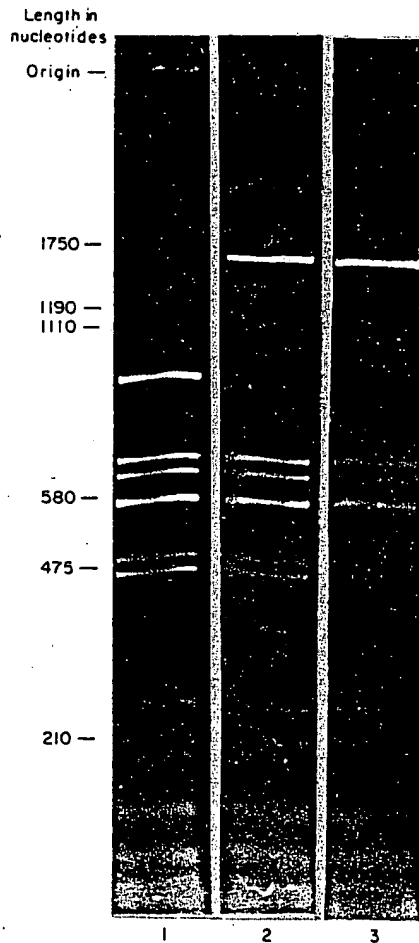

FIG. 3. Size analysis of the *Hae*III restriction fragments of plasmids 8/1/2 and 11/7/10. Approximately 1  $\mu$ g of each plasmid DNA was digested to completion with *Hae*III and the digest was analyzed on 3% acrylamide gels prepared and run as described by Maniatis *et al.* (1975). The molecular weight markers indicated show the position of migration of the *Hin*III restriction fragments of simian virus 40 DNA. Lane 1 is PMB9, lane 2 is 8/1/2 and lane 3 is 11/7/10. Note the extra *Hae*III fragment of 320 nucleotides in the 11/7/10 digest.

"internal" *EcoRI* fragment in the cloned segment of 11/7/10 which is approximately 500 nucleotides in length. For many of our other plasmids we are uncertain of the insert length, but of course we know that a fragment has been cloned which is sufficient long to hybridize to RNA under the moderately stringent hybridization conditions we have used (because of this we have now been able to use these cDNA clones to screen a  $\lambda$  phage recombinant pool for genomic fragments of slime mould DNA containing these sequences, and these will of course have a high probability of containing the entire coding sequence and its adjacent region).

The high efficiency of the cloning procedure (see Materials and Methods) and the presumed low abundance in the clone bank of each of these sequences makes it improbable that the same sequence would be isolated several times in a screen of this

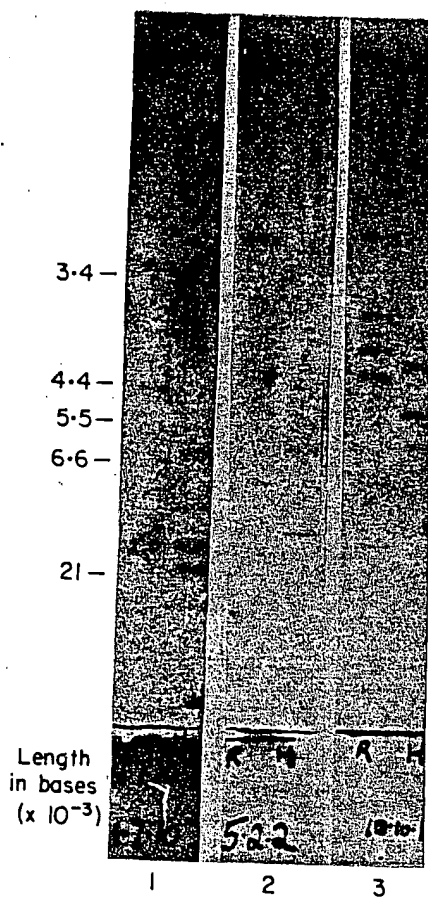

FIG. 4. Analysis of the genomic DNA restriction fragments hybridizing to plasmids 11/7/10, 10/10/1 and 5/2/2. Each lane of an 0.8% agarose gel was loaded with 1  $\mu$ g of total *D. discoideum* nuclear DNA digested with either *EcoRI* or *HinIII*. After electrophoresis the gel was processed by the transfer procedure of Southern (1975) and hybridized with  $5 \times 10^8$  cts/min of nick-translated DNA (spec. act.  $10^7$  to  $2 \times 10^7$  cts/min per  $\mu$ g). For plasmids 10/10/1 and 5/2/2, hybridization and washing were performed in  $3 \times$  SSC at  $55^\circ\text{C}$  (using the procedure described by Jeffreys & Flavel, 1977). In the case of plasmid 11/7/10 an extra washing in  $0.3 \times$  SSC at  $65^\circ\text{C}$  was performed to reduce non-specific binding which obscured part of the film (this washing step was not performed with the other 2 plasmids in order that the maximum number of complementary fragments might be detected (see text)). Lane 1 was hybridized with plasmid 11/7/10, lane 2 was hybridized with plasmid 5/2/2 and lane 3 was hybridized with plasmid 10/10/1. In each case the left-hand lane of the pair contained the *EcoRI* digest and the right-hand lane the *HinIII* digest. Exposure was for 4 weeks with an intensification screen. The molecular weight markers show the migration positions of an *EcoRI* digest of  $\lambda$  DNA.

ich is approximately  
are uncertain of the  
d which is sufficiently  
ization conditions we  
DNA clones to screen  
uld DNA containing  
ty of containing the

id Methods) and the  
quences makes it im  
s in a screen of this

size. Also the low abundance developmental cDNA clones showed a small but quite reproducible difference in the amount of hybridization obtained with mRNA isolated at different stages of development. However, since the overall level and time course of synthesis are quite similar, we felt it necessary to establish that each of the cDNA clones indeed contains a different nucleic acid sequence.

We decided to test this by determining the sizes of the *D. discoideum* genomic DNA restriction fragments complementary to the cloned cDNA inserts in three of the low abundance cDNA clones (5/2/2, 11/7/10 and 10/10/1) which hybridized to mRNA species with very similar developmental profiles. Plasmid DNA, labelled to a high specific activity by nick-translation, was hybridized to a Millipore filter bearing the *EcoRI* and *HinIII* restriction fragments of *D. discoideum* DNA which had been transferred from an agarose gel (Southern, 1975). Each cDNA clone hybridized to different sized restriction fragments (Fig. 4) which proves that these clones are derived from different *D. discoideum* mRNA sequences. Two or more hybridization bands were observed for all three cDNAs. Since some of these cloned DNAs do not contain a *HinIII* or *EcoRI* restriction site this could indicate the presence of multiple copies of

TABLE 2

*Inhibition of nuclear RNA synthesis by  $\alpha$ -amanitin*

Plasmid DNA bound to filter	Concentration of $\alpha$ -amanitin ( $\mu$ g/ml)	Nuclear preparation 1			Nuclear preparation 2		
		Cts/min bound	Cts/min minus PMB9 binding	Inhibition by $\alpha$ -amanitin	Cts/min bound	Cts/min PMB9 binding	Inhibition by $\alpha$ -amanitin
PMB9	0	43	—	—	35	—	—
	10	12	—	—	17	—	—
8/1/2	0	180	137	98%	97	62	97%
	10	15	3	—	19	2	—
5/2/2	0	106	63	79%	107	72	83%
	10	25	13	—	29	12	—
10/10/1	0	88	45	78%	95	60	74%
	10	23	10	—	27	10	—
11/7/10	0	79	36	84%	70	35	89%
	10	18	6	—	21	4	—
AT2.2.3 ribosomal DNA plasmid	0	39,000	—	—	21,000	—	—
	10	30,650	—	22%	19,149	—	9%

Nuclei from cells at the 9th h of development were isolated using the procedure described by Jacobson (1976). Nuclei from about  $10^9$  cells were incubated for 15 min at 22°C in the presence or absence of  $\alpha$ -amanitin at 10  $\mu$ g/ml using a minor modification of the incubation conditions described by Jacobson (1976) (Williams & Lloyd, manuscript in preparation). The two nuclear preparations used were prepared from different batches of cells. The level of inhibition of the  $\alpha$ -amanitin-treated sample was determined by removing a portion before and after incubation and determining the number of counts bound to DEAE discs after washing in 5% disodium hydrogen orthophosphate. Nuclear preparation 1 was inhibited by 77% and nuclear preparation 2 by 68%. The total yield from each reaction was extracted with phenol and passed over Sephadex G50. After precipitation with ethanol each RNA sample was resuspended in 0.5 ml of hybridization buffer and hybridized in separate tubes with the indicated plasmid DNA, and in addition with the ribosomal plasmid DNA. The total input into each tube was as follows. Nuclear preparation 1 without  $\alpha$ -amanitin 178,000 cts/min. Nuclear preparation 1 with  $\alpha$ -amanitin 90,000 cts/min. Nuclear preparation 2 without  $\alpha$ -amanitin 132,000 cts/min. Nuclear preparation 2 with  $\alpha$ -amanitin 66,000 cts/min.

g to plasmids 11/7/10,  
of total *D. discoideum*  
the gel was processed  
cts/min of nick-trans.  
id 5/2/2, hybridization  
scribed by Jeffreys &  
at 65°C was performed  
tep was not performed  
rtary fragments might  
2 was hybridized with  
e the left-hand lane of  
rest. Exposure was for  
he migration positions

these genes or alternatively inserts of non-coding DNA. We are currently performing a more extensive study of the gene organization in and around these sequences.

The method of construction of these clones (cDNA synthesis in an oligo(dT) dependent reaction), and the absence of any detectable level of hybridization with poly(A)<sup>-</sup> RNA, indicates that these clones are derived from polyadenylated RNA sequences and are therefore presumably mRNAs. However, we felt it necessary to establish this in as far as is possible (in the long term we intend to identify proteins encoded by these RNAs using positive (Noyes & Stark, 1975) or negative (Patterson *et al.*, 1977) selection of RNA and translation in a cell-free system). Accordingly, we determined the  $\alpha$ -amanitin-sensitivity of the nuclear polymerase responsible for synthesis of each of these RNA species (Table 2). This drug has been shown to inhibit selectively, RNA polymerase II, the enzyme responsible for synthesis of the nuclear precursor to mRNA in eukaryotes (including *D. discoideum* (Jacobson *et al.*, 1974)). To monitor the effects of  $\alpha$ -amanitin we determined both the inhibition of total RNA synthesis and the inhibition of ribosomal RNA synthesis (by hybridizing with the genomic ribosomal DNA plasmid). Ribosomal RNA synthesis was hardly affected by the level of  $\alpha$ -amanitin used, but synthesis of nuclear RNA complementary to DNA from each of the four developmental plasmids tested was inhibited by 80 to 90%.

We have also shown that the RNA complementary to the DNA in these plasmids is

TABLE 3

*The distribution of developmentally regulated poly(A)<sup>+</sup> RNAs between polysomes and polysomal supernatant*

Source of DNA on filter	Fraction of polysome gradient	Percentage of input mRNA complementary to DNA on filter	Percentage of the total mRNA population	Fraction of the mRNA complementary to the DNA on the filter which is polysome associated (%)
GC5/2/2	Pellet	0.48	0.37	88
	Supernatant	0.20	0.05	
GC5/8/3	Pellet	0.74	0.57	88
	Supernatant	0.33	0.08	
GC8/1/2	Pellet	0.09	0.07	58
	Supernatant	0.19	0.04	
GC10/10/1	Pellet	0.05	0.04	44
	Supernatant	0.23	0.05	
GC11/7/10	Pellet	0.48	0.37	96
	Supernatant	0.06	0.014	

Cells at the 8th hour of development were incubated for 5 min with 500  $\mu$ g cycloheximide/ml (to inhibit "run off") and a 6 ml cytoplasmic extract was prepared as described in Materials and Methods. This was layered over a 6-ml cushion of 1 M-sucrose, in a Beckman in SW41 tube, and spun for 16 h at 27,000 revs/min and at 4°C. This yielded a polysomal pellet (Jacobson, 1976) and a supernatant fraction both of which were extracted with phenol. Using [<sup>3</sup>H]poly(U) hybridization as an assay for poly(A)<sup>+</sup> RNA, 9  $\mu$ g (23% of total) of the poly(A)<sup>+</sup> RNA was estimated to be in the supernatant and 30  $\mu$ g (77% of total) in the pellet. Polyadenylated RNA was selected from both fractions and the RNA was end-labelled as before. Duplicate filter sections were hybridized with each RNA preparation and, after correction for the ribosomal RNA contamination and background binding as described previously, the average value was corrected for hybridization efficiency. This gave the percentage of input poly(A)<sup>+</sup> RNA complementary to the DNA on the filter. This was then expressed as a percentage of the total poly(A)<sup>+</sup> RNA population in each fraction by multiplying by 0.77 for the polysomal and 0.23 for the non-polysomal RNA.



currently performing these sequences.

esis in an oligo(dT) of hybridization with polyadenylated RNA. We felt it necessary to identify proteins for negative (Patterson et al.). Accordingly, we have shown to inhibit synthesis of the nuclear (Jacobson *et al.*, 1974)) inhibition of total RNA hybridizing with the as hardly affected by complementary to DNA and by 80 to 90%. In these plasmids is

between polysomes

Fraction of the RNA complementary to the DNA on the filter which is polysome associated (%)

88

88

58

44

96

0.5  $\mu$ g cycloheximide/ml as described in Materials and Methods and in SW41 tube, and actinomycin D (Jacobson, 1976). [3H]poly(U) hybridization - RNA was estimated by scintillation counter. Selected RNA was selected by sucrose gradient centrifugation. Sections were hybridized with complementary DNA and extracted for hybridization with complementary DNA on the filter. A population in each polysome RNA.

associated with a polysomal fraction (Table 3). For three out of the five plasmids analyzed, almost all the complementary RNA is polysome-associated. The concentration of the RNA complementary to the DNA in the other two plasmids (where half of the RNA is not polysome-associated) is falling at eight hours of development (Fig. 2 and unpublished data). It seems possible that when a mRNA is no longer being actively synthesized it may become disengaged from the polysomes, although we have no direct evidence for this hypothesis.

#### 4. Discussion

The main aim of these experiments was to isolate hybridization probes which can be used to analyze the expression of developmentally regulated genes in *D. discoideum*. This has been achieved using a modification of the Grunstein-Hogness *in situ* hybridization technique which allows detection of bacterial clones containing DNA complementary to poly(A)+ RNA species which are present at very low concentration. This procedure should be applicable to any situation where mRNA populations are to be compared with a view to isolating stage-specific or cell type-specific hybridization probes. Aside from the technical aspects of this paper, two important conclusions can be drawn.

(a) *The concentration of individual high and medium abundance poly(A)+ RNA species changes during development*

This conclusion is based on the data presented in Table 1 and Figure 2. Our study differs from previous hybridization studies in which total poly(A)+ RNA populations were compared and in which RNA excess hybridization techniques were used (Firtel, 1972; Lodish *et al.*, 1978). Because DNA excess hybridization was used in this present study, it was possible to measure changes in the concentration of individual high and medium abundance poly(A)+ RNA species. While the analysis of Rot curves can yield information about large changes in a major fraction of a single abundance class (such as the loss of a complete abundance class, for example see Williams *et al.*, 1977), it is not possible to measure less dramatic changes of the kind observed here. There is indirect evidence for a control of protein synthesis at the level of individual mRNA transcripts from studies using transcriptional inhibitors such as actinomycin and daunomycin (for a review of these experiments see Loomis, 1975), but conclusions derived from such experiments must always be treated with extreme caution because of possible secondary effects of the drugs. Further indirect evidence for changes in the level of individual mRNA species has come from the work of Alton & Lodish (1977) who analyzed the proteins synthesized at various stages of development using two-dimensional gel electrophoresis. They isolated RNA from cells at different stages of development and showed that, for several of these proteins, the time of appearance of translatable mRNA correlated with the time of appearance of labelled protein *in vivo*. However, this experiment only measures protein synthetic activity in a wheat germ cell-free system so that some change in mRNA structure such as a change in "capping" could account for the observed result. We have shown directly that the concentration of several mRNA species increases at around the time Alton & Lodish (1977) detected new species of protein (8 to 10 h, which both under our conditions of development and those of Alton and Lodish is the post-aggregative phase, see Fig. 2(a) and the

description of cell growth and development in Materials and Methods). It seems likely that these changes in mRNA concentration are reflected in a change in the rate of synthesis of the proteins encoded by them.

(b) *The fraction of high abundance and medium abundance poly(A) + RNA species whose concentration increases significantly during the first eight hours of development is quite low*

This conclusion is based on the data presented in Table 1. Of the 130 cloned DNA sequences which hybridized detectably with 8-h (A)+ RNA (see below) only ten (or around 8% of the total) hybridized to an RNA which increased in concentration by more than threefold during this first eight hours of development. In attempting to draw any conclusions from these numbers we are making the assumption that a representative sample of the poly(A)+ RNA population has been screened. The cloning procedure would not be expected to select specifically for or against those RNA species whose concentration changes during development. It should not therefore affect our estimate of the fraction of the poly(A)+ RNA population in this class. However, we are selective in that we have cloned DNA sequences derived from poly(A)+ RNA isolated at the eighth hour of development. Thus any developmentally regulated poly(A)+ RNA whose concentration decreased during development sufficiently such that it constituted only a very small proportion of the RNA population at eight hours would be selected against by our procedure. Therefore we have not attempted to draw any conclusions about the fraction of the poly(A)+ RNA population which decreases in concentration during development. It is also important to note that our estimate of the fraction of poly(A)+ RNA species whose concentration increases significantly is only an approximation. Clearly in any screen of this kind some clones whose complementary poly(A)+ RNA increases in concentration during development may be overlooked if they show near background levels of hybridization. Also, as explained in the legend to Figure 1, only 130 of the 250 clones screened were adjudged to have above background levels of hybridization with eight-hour developmental poly(A)+ RNA, and there is a degree of uncertainty in this estimate. There is also the possibility that some clones will have been picked more than once and, if this were selective for either the developmental or the non-developmental clones, this would affect our estimate.

Because the hybridization procedure we have used only detects poly(A)+ RNA species constituting more than 0.1% of the population, we are only studying the high and medium abundance poly(A)+ RNA species. Therefore our results cannot be compared with results obtained using RNA excess hybridization to single copy genomic DNA (Firtel, 1972) or to cDNA (Lodish *et al.*, 1978) which measures total sequence complexity and is primarily a measurement of the lowest abundance class in the RNA population. However, the level of detection of poly(A)+ RNA in our experiments is comparable with the level of detection of proteins in the two-dimensional gel analysis of *D. discoideum* proteins performed by Alton & Lodish (1977). They could only detect approximately 400 different proteins in vegetative cells and these would presumably be encoded by high and medium abundance mRNA species. During the period of development from eight to ten hours approximately 40 new protein species were synthesized. Therefore our estimate of the fraction of poly(A)+ RNA species whose concentration increases during this period of development (approximately 8%) agrees reasonably closely with the estimated fraction of new proteins.

We thank our  
microscopy facil

- Alton, T. H. &  
Bailey, J. M. &  
Bishop, J. O., 1  
250, 199-20  
Boyer, H. & R  
Dottin, R., Wei  
Firtel, R. A. (19  
Firtel, R. A., Ja  
Firtel, R. A., K  
35, 13-22.  
Grunstein, M. &  
Henderson, E. J  
Humphries, P.,  
*Nucl. Acids*  
Jacobson, A. (19  
Marcel Dek  
Jacobson, A., F.  
Jeffreys, A. J. &  
Laskey, R. A. &  
Lodish, H. F.,  
*Winter Sym*  
Loomis, W. F.  
Press Inc.,  
Maniatis, T., Je  
Miller, J. H. (1  
Harbour La  
Monahan, J. A  
7355-7362.  
Noyes, B. E. &  
Patterson, B. M  
4370-4374.  
Rougeon, F. &  
Roychoudry, R.  
Salser, W., Bro  
Studrick, G  
Schenk, T. E.,  
72, 989-993  
Southern, E. (19  
Town, C. & Gro  
Warren, A. J.,  
1041-1042.  
Watts, D. J. &  
Williams, K. L.  
Williams, J. G.,

We thank our colleagues for helpful discussion and R. Tilly for providing electron microscopy facilities.

## REFERENCES

- Alton, T. H. & Lodish, H. F. (1977). *Develop. Biol.* **60**, 180-207.
- Bailey, J. M. & Davidson, N. (1976). *Anal. Biochem.* **70**, 75-85.
- Bishop, J. O., Morton, J. G., Rosbash, M. & Richardson, M. (1974). *Nature (London)*, **250**, 199-204.
- Boyer, H. & Roulland-Dussoix, D. (1969). *J. Mol. Biol.* **41**, 459-472.
- Dottin, R., Weiner, A. & Lodish, H. (1976). *Cell*, **8**, 233-244.
- Firtel, R. A. (1972). *J. Mol. Biol.* **66**, 363-377.
- Firtel, R. A., Jacobson, A. & Lodish, H. F. (1972). *Nature New Biol.* **239**, 225-229.
- Firtel, R. A., Kindle, K. & Huxley, M. P. (1976). *Fed. Proc. Fed. Amer. Soc. Exp. Biol.* **35**, 13-22.
- Grunstein, M. & Hogness, D. (1975). *Proc. Nat. Acad. Sci., U.S.A.* **72**, 3961-3965.
- Henderson, E. J. (1975). *J. Biol. Chem.* **250**, 4730-4736.
- Humphries, P., Cochet, M., Krust, A., Gerlinger, P., Kourilsky, P. & Chambon, P. (1977). *Nucl. Acids Res.* **4**, 2389-2406.
- Jacobson, A. (1976). In *Methods in Molecular Biology* (Last, J. A., ed.), vol. 8, pp. 161-209, Marcel Dekker, New York.
- Jacobson, A., Firtel, R. A. & Lodish, H. F. (1974). *J. Mol. Biol.* **82**, 213-230.
- Jeffreys, A. J. & Flavell, R. A. (1977). *Cell*, **12**, 429-439.
- Laskey, R. A. & Mill, A. D. (1977). *FEBS Letters*, **82**, 314-316.
- Lodish, H. F., Margolskee, J. P. & Blumberg, D. D. (1978). *Proceedings of the Miami Winter Symposium*, Academic Press Inc., New York.
- Loomis, W. F. (1975). In *Dictyostelium discoideum. A developmental system*, Academic Press Inc., New York.
- Maniatis, T., Jeffrey, A. & van der Sande, J. (1975). *Biochemistry*, **14**, 3787-3794.
- Miller, J. H. (1972). In *Experiments in Molecular Genetics*, pp. 137-138, Cold Spring Harbour Laboratory, Cold Spring Harbour, New York.
- Monahan, J. A., McReynolds, L. A. & O'Malley, B. W. (1976). *J. Biol. Chem.* **251**, 7355-7362.
- Noyes, B. E. & Stark, G. R. (1975). *Cell*, **5**, 301-310.
- Patterson, B. M., Roberts, B. E. & Kuff, E. L. (1977). *Proc. Nat. Acad. Sci., U.S.A.* **74**, 4370-4374.
- Rougeon, F. & Mach, B. (1976). *Proc. Nat. Acad. Sci., U.S.A.* **73**, 3418-3422.
- Roychoudry, R., Jay, E. & Wu, R. (1976). *Nucl. Acids Res.* **3**, 101-116.
- Salser, W., Browne, J., Clarke, P., Hienall, H., Higuchi, R., Paddock, G., Roberts, J., Studrick, G. & Zakar, P. (1976). *Progr. Nucl. Acid Res. Mol. Biol.* **19**, 177-203.
- Schenk, T. E., Rhodes, C., Rigby, P. & Berg, P. (1975). *Proc. Nat. Acad. Sci., U.S.A.* **72**, 989-993.
- Southern, E. (1975). *J. Mol. Biol.* **98**, 503-517.
- Town, C. & Gross, J. (1978). *Develop. Biol.* **63**, 412-420.
- Warren, A. J., Warren, W. D. & Cox, A. C. (1975). *Proc. Nat. Acad. Sci., U.S.A.* **72**, 1041-1042.
- Watts, D. J. & Ashworth, J. M. (1970). *Biochem. J.* **119**, 171-174.
- Williams, K. L. & Newell, P. C. (1976). *Genetics*, **82**, 287-307.
- Williams, J. G., Hoffman, R. & Penman, S. (1977). *Cell*, **11**, 901.

## Use of a Cloned Library for the Study of Abundant Poly(A)<sup>+</sup>RNA during *Xenopus laevis* Development

MARK B. DWORKIN AND IGOR B. DAWID

Laboratory of Biochemistry, National Cancer Institute, National Institutes of Health,  
Bethesda, Maryland 20205

Received September 7, 1979; accepted November 2, 1979

Over 200 cloned sequences from recombinant DNA libraries prepared from *Xenopus laevis* embryonic poly(A)<sup>+</sup>RNA have been analyzed by colony hybridization with [<sup>32</sup>P]cDNA prepared from poly(A)<sup>+</sup>RNA from several stages of development. The period of early embryogenesis extending through the beginning of gastrulation (stage 10) is marked by the relative constancy of the abundant poly(A)<sup>+</sup>RNA population. Between the gastrula and tailbud stages (stage 24) there is a dramatic change in the pattern of abundant poly(A)<sup>+</sup>RNA species; the new pattern remains fairly constant for at least 2 days of development to the late prefeeding tadpole stages (stage 41). We have also compared nonpolysomal and polysomal poly(A)<sup>+</sup>RNA populations at two different stages. In stage 10 (early gastrula) postribosomal (free ribonucleoprotein) and polysomal poly(A)<sup>+</sup>RNA populations partly overlap; however, many cloned sequences occur in quite different concentrations in one fraction or the other. Among the sequences that are predominantly nonpolysomal at gastrula few become predominantly polysomal at tailbud stages. Thus, we have no evidence for a major recruitment of abundant nonpolysomal RNAs into polysomes with progressing development. We rather observe a general pattern in which a cloned sequence that is nonpolysomal in one stage of development tends to be nonpolysomal (if detectable at all) in other stages as well.

### INTRODUCTION

In the preceding paper (Dworkin and Dawid, 1980) we state the aim of this work as an attempt to analyze the developmental behavior of a set of RNA molecules during embryogenesis in *Xenopus laevis*. As a first step in that direction, the paper described the production of cDNA<sup>1</sup> libraries containing a large number of sequences derived from poly(A)<sup>+</sup>RNA molecules from two embryonic stages. An adaptation of the colony hybridization method of Grunstein and Hogness (1975) was used to characterize certain features of 860 clones which had been selected randomly from the two cDNA libraries. We have correlated the intensity of the hybridization signal with the abundance of the homologous sequence

in the radioactive probe. Clones which show no detectable autoradiographic signal when hybridized by colony hybridization contain sequences that comprise less than about 0.06% of the radioactive probe while positive clones contain sequences homologous to increasingly larger fractions of the probe. Using this colony hybridization procedure we found that about 20% of the clones showed detectable signals of varying intensities when hybridized with [<sup>32</sup>P]cDNA synthesized from homologous RNA. In the present paper we report experiments in which these 860 clones were hybridized with [<sup>32</sup>P]cDNA copied from a variety of RNA populations.

The fertilized egg of *X. laevis* reaches gastrulation in 10 to 12 hr at 22 to 25°C and 1 day later the embryo has progressed through neurulation to the tailbud stage in which many organ anlagen have been laid down. Two days later the tadpole has used

<sup>1</sup> Abbreviations used: cDNA, complementary DNA, referring to DNA synthesized *in vitro*; kb, kilobase or kilobase pair; RNP, ribonucleoprotein.

up most of its yolk and many organ systems have differentiated extensively. The RNA samples tested were prepared from several stages spanning development, including the egg, cleavage stages, gastrulae, tailbud embryos, and late prefeeding tadpoles, as well as from whole ovaries and adult liver. We have prepared polysomal and nonpolysomal RNA fractions from gastrulae and late tadpoles and have tested these fractions separately. Over 200 cloned sequences gave a detectable signal with at least one of these [ $^{32}\text{P}$ ]cDNA probes and thus we were able to describe the developmental behavior of these sequences. These clones contain sequences that represent the most abundant poly(A)<sup>+</sup>RNA species in the embryo. These sequences can be divided into groups of differing developmental behavior or cellular location and representatives of the various groups can be selected for more detailed study.

#### MATERIALS AND METHODS

##### *Cellular Fractionation and Preparation of RNA*

Embryos were harvested at various stages (Nieuwkoop and Faber, 1967) and rinsed in ice-cold water. Total ovary or liver was excised from animals, minced, and rinsed in 0.015 M NaCl. Mature eggs were extruded into the medium by injecting females with gonadotropin in the absence of males.

Cellular fractions were prepared by homogenizing approximately 1000 embryos at 0°C in a Dounce-type homogenizer with several strokes of a tight-fitting pestle in 40 ml of Woodland homogenization buffer [20 mM Tris-HCl, pH 7.4 (20°C), 0.3 M KCl, 10 mM MgCl<sub>2</sub>] (Woodland, 1974) plus 0.5% NP-40 and 10–20 µg/ml each of spermine and polyvinylsulfate or 2 mg/ml bentonite. The homogenate was centrifuged at 15,000g and cytoplasmic fractions were prepared from the supernatant (S15). The pellet (P15) was resuspended in Woodland buffer and centrifuged at 15,000g through 1 M sucrose in the same buffer to produce the

pellet fraction (pel). The pellet fraction should be enriched for nuclei. Further fractionation of the S15 was by one of two methods. (1) Samples of S15 were placed over 15–30% sucrose gradients in Woodland buffer and centrifuged for 12 hr at 26,000 rpm in the Beckman SW 27 rotor to place the 80 S ribosomes near the bottom of the gradient (Dworkin and Infante, 1976). The material from about 10 S to the middle of the monosome peak was collected as the free RNP preparation and precipitated with ethanol; the pellet was used directly as a source of polysomes. (2) Eighteen milliliters S15 was centrifuged through 11.7 ml 1.0 M sucrose (in Woodland buffer) onto a shelf of 4.4 ml 2.4 M sucrose at 27,000 rpm for 3.5 hr in the SW 27 rotor (Palacios *et al.*, 1972). Polysomes were recovered from the shelf, diluted with 3 vol of buffer without sucrose, treated for 20 min with 1 mM puromycin at 37°C (Blobel, 1971), and recentrifuged over an identical discontinuous gradient. The puromycin released RNP was recovered by collecting the entire solution above the shelf area, and precipitated with ethanol.

RNA was extracted from these fractions as well as from total cells, and poly(A)<sup>+</sup>RNA was separated as described in the preceding paper. Cytoplasmic poly(A)<sup>+</sup>RNA concentrations were determined by hybridizing aliquots of RNA to [ $^3\text{H}$ ]poly(U) (Bishop, 1974), and calculating on the basis that the poly(A) segment is 5% of poly(A)<sup>+</sup>RNA (Miller, 1978).

The RNA preparations used in these experiments are listed in Table 1 along with the yields obtained and the abbreviations used in the text. All comparisons involving polysomal preparations are based on puromycin released polysomal fractions.

##### *Colony Hybridization and Cataloguing of Clones*

Preparation of [ $^{32}\text{P}$ ]cDNA probes from the poly(A)<sup>+</sup>RNA listed in Table 1 and colony hybridization to bacterial colonies denatured *in situ* are described in the pre-

TABLE 1  
POLY(A)<sup>+</sup>RNA PREPARATIONS

Abbreviation	Approx. yield per 1000 embryos <sup>a</sup> (μg)	Description
1 Ov		Total ovary
2 Liv		Liver, 15,000g supernatant
3 Egg		Total mature, unfertilized egg
4 Cl		Total cleavage stage (stages 3-7)
5 10T	5	Total stage 10-11 (early gastrulae)
6 10pel <sup>b</sup>		Stage 10-11, 15,000g pellet
7 10R	1.5	Stage 10-11, postribosomal (free RNP)
8 10P <sup>c</sup>	3	Stage 10-11, polysomal
9 24P <sup>c</sup>	3	Stage 24 (tailbud), polysomal
10 41T	30 <sup>d</sup>	Total stage 41 (swimming tadpoles)
11 41pel	15 <sup>d</sup>	Stage 41, 15,000g pellet
12 41P <sup>c</sup>	12	Stage 41, polysomal
13 41R	≤0.2	Stage 41, postribosomal (free RNP)

<sup>a</sup> Determined by [<sup>3</sup>H]poly(U) hybridizations, assuming poly(A) is 5% of poly(A)<sup>+</sup>RNA (Miller, 1978).

<sup>b</sup> The pellet was recentrifuged through 1 M sucrose at 15,000g. The pellet contained 25% of the cellular RNA but very little poly(A)<sup>+</sup>RNA.

<sup>c</sup> 10P RNA was prepared either from a polysome pellet or from puromycin released RNP (see Materials and Methods). All subsequent tables are compiled from the data obtained with puromycin released RNP preparations; 24P and 41P RNA were prepared from puromycin released RNP.

<sup>d</sup> Judged by its ability to support [<sup>32</sup>P]cDNA synthesis, this value is likely to be an overestimate of the amount of poly(A)<sup>+</sup>RNA in 41pel and 41T.

preceding paper. Colonies were catalogued into three levels of hybridization by repeated screenings with [<sup>32</sup>P]cDNA probes of 860 clones selected at random. Colony hybridizations under these conditions are very reproducible (Thayer, 1979). In most cases film exposure times and amounts of radioactivity were varied to an equivalent of 20 × 10<sup>6</sup> cpm/25 ml for 5 days for the various [<sup>32</sup>P]cDNA preparations.

## RESULTS

### *Comparisons of RNA Populations*

RNA samples were prepared from em-

bryos at different stages and from some tissues and some cell fractions, as listed in Table 1. In every case poly(A)<sup>+</sup>RNA was separated and used for the synthesis of [<sup>32</sup>P]cDNA. The [<sup>32</sup>P]cDNA preparations were used as probes in colony hybridization experiments with a set of 860 randomly chosen clones containing inserts of cDNA derived from *Xenopus* RNA. As described in the preceding paper (Dworkin and Dawid, 1980), the selected group of clones included 240 examples from the stage 10 library and 620 examples from the stage 41 library. We also showed in the preceding paper that about 20% of these clones gave a detectable hybridization signal in the homologous colony hybridization. The large majority of the remaining clones do contain cDNA inserts which probably were derived from low abundance RNAs. About 30% of the 860 clones gave a detectable signal with the poly(A)<sup>+</sup>RNA probes listed in Table 1. These 240 positive clones were assembled on filter sheets and hybridized again with the various [<sup>32</sup>P]cDNA probes, and a sampling of the resulting autoradiographs is shown in Figs. 1-3. Some of these clones contain copies of the same sequence and these are indicated in Table 2 of the preceding paper.

The hybridization signals shown by each clone with the 13 [<sup>32</sup>P]cDNA probes were classified into three intensity levels as described in the preceding paper. This cataloguing resulted in a large amount of raw data that represent approximate distributions of abundances of many RNA species in the test populations. All of the data described below can be found in Figs. 1-3 although the data are actually collected from several similar experiments. A comparison of 16 pairs of RNA populations derived from colony hybridization to [<sup>32</sup>P]cDNA probes is summarized in Table 2. The "percentage similar" column tabulates the percentage of clones giving signals of near equal intensities, while the "percentage different" column includes clones showing level 2 or higher intensity with one

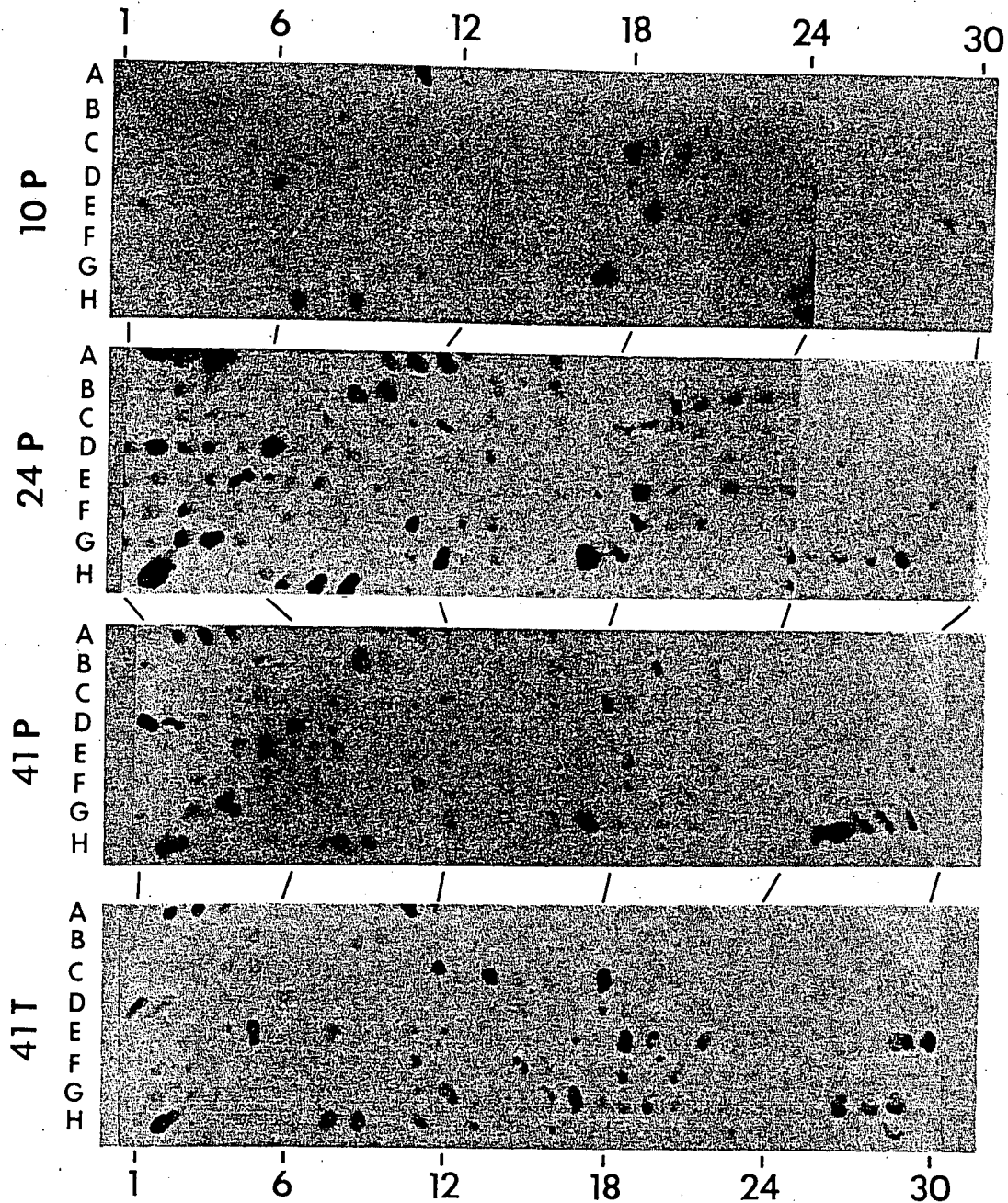

FIG. 1. Colony hybridization of 240 clones to 10P, 24P, 41P, and 41T probes. A subset of 240 clones of the original 860 clones used for colony hybridization were collected and hybridized again to a series of [ $^{32}\text{P}$ ]cDNA probes prepared from various poly(A)<sup>+</sup>RNA preparations. These 240 clones gave a detectable signal with at least one probe during the initial screenings. This figure shows, from top to bottom, the hybridization of these 240 clones with probes from 10P, 24P, 41P, and 41T (see Table 1). All polysomal poly(A)<sup>+</sup>RNA preparations are derived from puromycin released RNP. The coordinates help identify the location of individual clones referred to in the tables and text.

[ $^{32}\text{P}$ ]cDNA probe that are undetectable with the other probe. On the basis of calibrations shown in the preceding paper, clones listed in the "different" column contain *Xenopus* sequences that occur at concentrations at least fivefold different in the

two [ $^{32}\text{P}$ ]cDNA probes that are compared. Many of the differences are likely to be much higher than fivefold. The "intermediate" column represents sequences that are present at different concentrations in the two [ $^{32}\text{P}$ ]cDNA probes, but where the

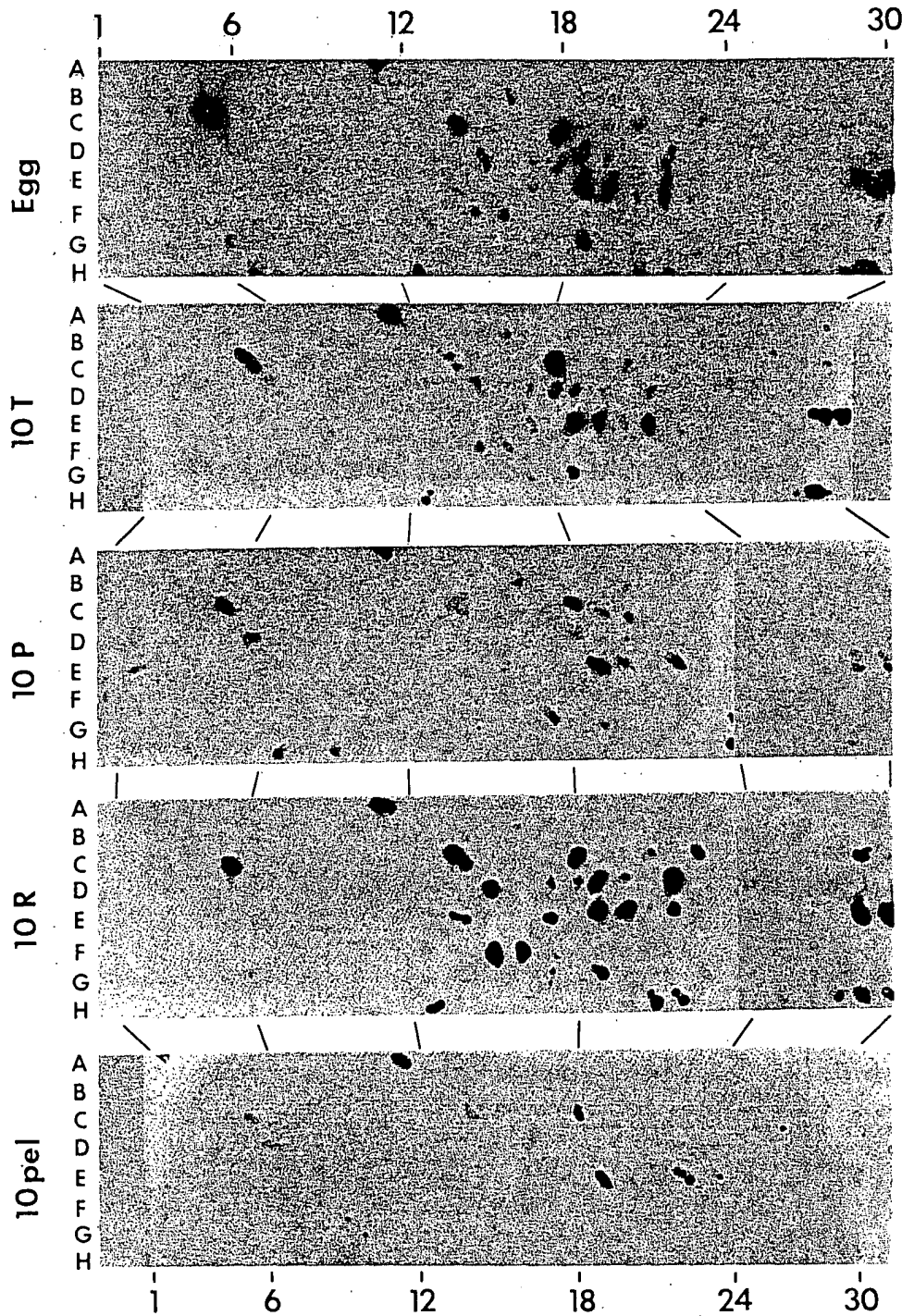

FIG. 2. Colony hybridization of 240 clones to egg, 10T, 10P, 10R, and 10pel probes (see also legend to Fig. 1). The 10P poly(A)<sup>+</sup>RNA was prepared from the polysome pellet of the 10R preparation.

difference is small and somewhat uncertain because of the semiquantitative nature of the assay. To derive an overall measure of similarity of two RNA populations the ratio of "similar" to "different" is listed in the last column of Table 2. This approach ignores the "intermediate" clones entirely

but additional comparisons described below will take some of these clones into account. The higher the ratio in the last column, the more similar are the two RNA populations. *Comparisons between total poly(A)<sup>+</sup>RNA from different stages of development.* This set of comparisons is made in



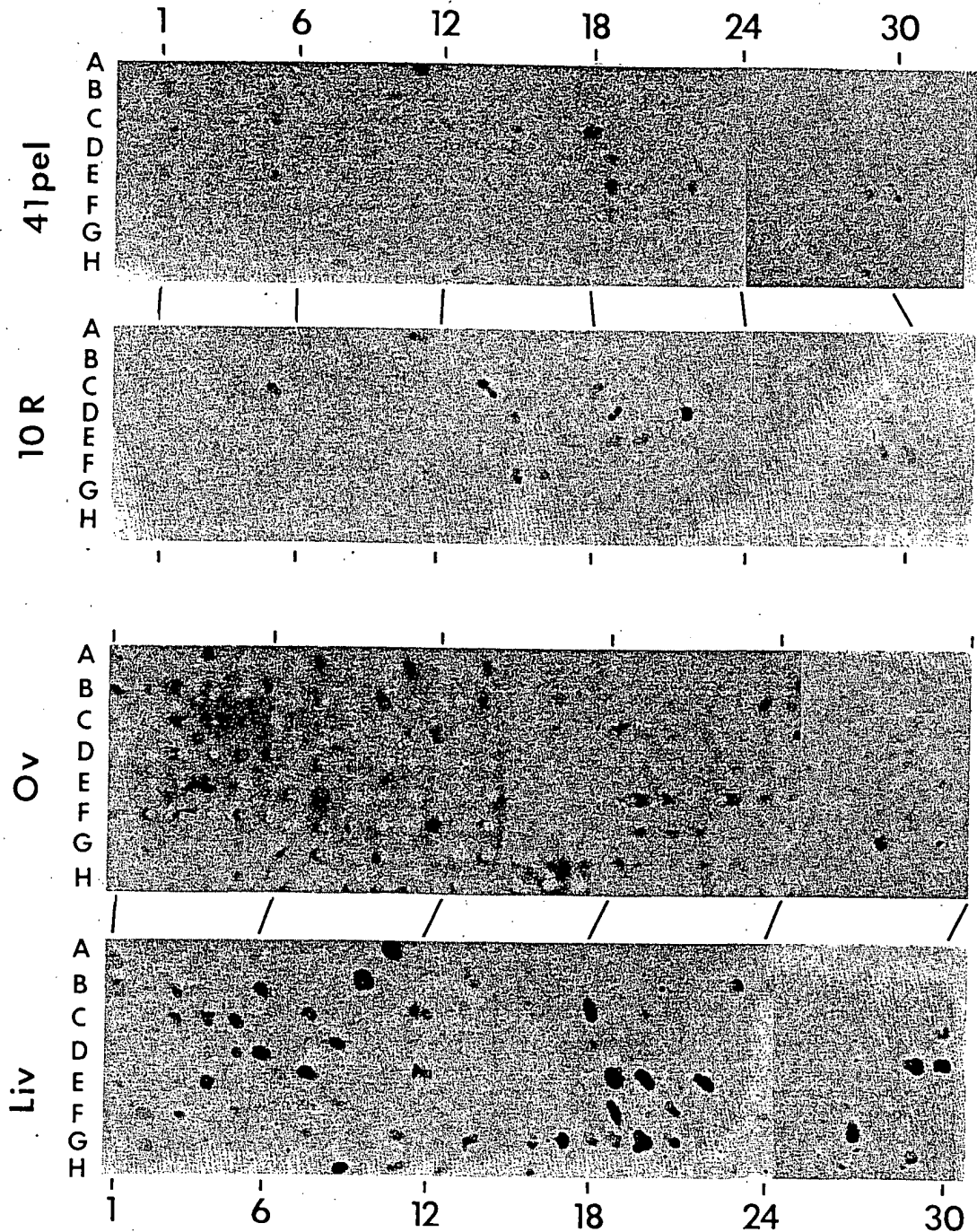

FIG. 3. Colony hybridization of 240 clones to 41pel, 10R, Ov, and Liv probes (see also legend to Fig. 1). The 10R autoradiograph is a shorter exposure of the one shown in Fig. 2.

lines A through G of Table 2. Lines A and B indicate great dissimilarity between the abundant sequences in total ovary and those in mature eggs (A) and stage 10 embryos (B). The basis of this difference between ovary and eggs, and ovary and stage 10, is illustrated in Table 3. Out of the 112 clones (Table 2) which gave a detectable

signal with either ovary or egg [ $^{32}\text{P}$ ]cDNA probes, 62 clones gave level 2 or 3 signals with one and no detectable signal with the other (adding up all four numbers in the Ov, egg comparison of Table 3). Ov [ $^{32}\text{P}$ ]cDNA probe did not react strongly with any clones but rather showed level 1 or level 2 reactions with many clones; in

TABLE 2  
SIMILARITIES AND DIFFERENCES BETWEEN VARIOUS RNA PREPARATIONS<sup>a</sup>

RNA preparations compared	(Number of clones)	Similar <sup>b</sup> (%)	Intermediate <sup>c</sup> (%)	Different <sup>d</sup> (%)	Similar/different <sup>e</sup>	
I. Total RNA populations						
A	Ov;Egg	(112)	20	25	55	0.36
B	Ov;10T	(112)	19	33	48	0.40
C	Ov;41T	(139)	45	17	37	1.2
D	Egg;10T	(64)	60	28	11	5.4
E	10T;41T	(136)	25	27	48	0.52
F	10T;Liv	(115)	20	34	43	0.47
G	41T;Liv	(143)	52	25	22	2.4
II. RNA from cell fractions						
H	10P;41P	(174)	25	33	42	0.59
I	10P;24P	(138)	27	29	44	0.61
J	24P;41P	(155)	81	13	7	12
K	10T;10P	(56)	54	36	11	4.9
L	10P;10R	(81)	21	50	28	0.75
M	10P;10pel	(45)	44	35	20	2.2
N	41T;41P	(141)	66	27	8	8.3
P	41P;41pel	(161)	71	13	11	6.4
Q	10R;24P	(162)	17	34	48	0.35

<sup>a</sup> Sixteen pairs of RNA preparations are compared in this table. [<sup>32</sup>P]cDNA was synthesized from each RNA sample and used for colony hybridization with the set of 860 clones. The RNA preparations being compared are listed in the first column, followed by the number of clones that gave a detectable signal to either probe.

<sup>b</sup> Percentage of clones showing either the same level of hybridization with both RNAs, or differing only by level 2 vs level 1 intensities.

<sup>c</sup> Percentage of clones showing dissimilar intensities between the two RNAs: clones that were categorized at level 3 in one RNA but at level 1 or 2 in the other RNA; and clones that are listed at level 1 in one RNA but undetectable in the other RNA.

<sup>d</sup> Percentage of clones that were categorized at level 2 or 3 in one RNA and were undetectable in the other RNA.

<sup>e</sup> The ratio of "similar" to "different." The higher this ratio, the more similar are the two RNA preparations.

contrast, egg [<sup>32</sup>P]cDNA probe reacted strongly with a small number of clones (Figs. 2 and 3). The vast majority of ovary specific clones (43 out of 46) are derived from the stage 41 library, while 15 of the 16 egg specific clones are from the stage 10 library. From this fact one would predict that egg and stage 10 RNAs are similar, and ovary and stage 41 RNAs are more closely related than ovary and egg. This is in fact true as shown in lines C and D of Table 2. In particular, egg and 10T are very similar, indicating little change in the array of abundant poly(A)<sup>+</sup>RNA species during the first 10 hr of development.

The difference between the stage 10 and stage 41 poly(A)<sup>+</sup>RNA is shown in line E of Table 2. This difference is further illustrated and broken down in line C of Table

3. There are 65 cloned sequences responsible for the differences between 10T and 41T RNAs; 62 of these clones give signals only with the 41T probe and 60 of these clones are from the stage 41 library. Only three clones react specifically to stage 10 [<sup>32</sup>P]cDNA probe and they are from the stage 10 library. Thus, stage 41 poly(A)<sup>+</sup>RNA includes most of the abundant stage 10 poly(A)<sup>+</sup>RNA sequences but mostly at lower abundance. Moreover, stage 41 embryos contain a number of additional high abundance RNAs which are either absent from stage 10 or present there at a low level. Lines F and G of Table 2 show the comparisons of 10T and 41T with liver, indicating the greater similarity between 41T and liver than between 10T and liver. The large number of stage 41 library

TABLE 3  
DISTRIBUTION OF STAGE SPECIFIC CLONES INTO  
DIFFERENT LIBRARIES<sup>a</sup>

RNAs compared	Number of clones in each library	
	Stage 10	Stage 41
A Ov (not Egg)	3	43
Egg (not Ov)	15	1
B Ov (not 10T)	4	40
10T (not Ov)	9	1
C 10T (not 41T)	3	0
41T (not 10T)	2	60
D 10P (not 24P)	0	0
24P (not 10P)	4	57
E 10P (not 41P)	2	3
41P (not 10P)	6	62
F 10R (not 24P)	9	1
24P (not 10R)	15	62

<sup>a</sup> The table shows six pairs of poly(A)<sup>+</sup>RNA preparations that were compared in Table 2. The clones under consideration are those from the percentage different column of Table 2; that is, clones which are present at level 2 or 3 in one RNA preparation but undetectable in the other. The table shows the number of clones which reacted with either probe that are in this group and from which library they are derived. For example, out of 62 clones that were detected at level 2 or level 3 with either Ov or Egg probe, and were undetected in the other, 46 were detected with Ov probe and 16 with Egg probe; 43 of the clones which reacted with the Ov probe were detected in the stage 41 library, while 15 of the clones which reacted with the Egg probe were detected in the stage 10 library.

clones that can be detected by a [<sup>32</sup>P]cDNA probe made from liver poly(A)<sup>+</sup>RNA was unexpected.

*Comparison of polysomal RNAs.* Preparations of RNA derived from puromycin released polysomes from stage 10 (10 hr of development), stage 24 (34 hr), and stage 41 (4 days) are compared in lines H through J of Table 2. There was little difference in the hybridization patterns whether the RNA was extracted from puromycin released polysomes (Fig. 1, 10P) or directly from a polysome pellet (Fig. 2, 10P); 10P and 41P RNAs are as dissimilar as 10T and 41T RNAs, and the distribution of differences is similar as well (Table 3, line E).

Surprisingly, 10P and 24P RNAs are equally dissimilar as 10P and 41P, and the difference lies entirely in 24P specific sequences found in the stage 41 library (Table 3, line D). One predicts, then, large similarity between 24P and 41P RNAs, and that is verified in line J in Table 2: 81% of the clones giving signals with either a 24P probe or a 41P probe give a signal of similar intensity with the other probe. Only 7% of the cloned sequences show a great difference between these two stages.

*Comparisons involving cell fractions from stage 10 embryos.* These data are summarized in lines K through M of Table 2. Although 10T and 10P (Table 2, line K) are very similar, the 11% difference derives from clones detected with 10T probe that were not detected with 10P probe. When 10P is compared to 10R, much dissimilarity is displayed with only 21% of clones in the similarity column. Examples of cloned sequences which are predominantly polysomal at stage 10 are C20, D6, and H7, while clones D15, D19, and F15 contain sequences which are predominantly non-polysomal at stage 10 (Fig. 2). This comparison shows that separation into polysomes and free RNP resulted in a meaningful fractionation of abundant RNAs. However, the difference between these two fractions is mostly in the concentration of RNAs, with 50% of the sequences in the "intermediate" column of Table 2. Thus we deal largely with disparate distributions of a qualitatively similar RNA population between 10P and 10R; 10P and 10pel RNAs are similar, and 10pel sequences absent from 10P are also found in 10R; 10pel should be enriched for nuclei but may also contain contamination with other cell fractions. We detected no 10pel specific sequences.

*Comparison of RNAs of cell fractions from stage 41 embryos.* These data are shown in lines N and P of Table 2. The comparison between 41T and 41P (Table 2, line N) reveals a large similarity with only an 8% difference. Sequences present in 41T

but absent or present at a low level in 41P likely represent nonpolysomal RNAs. These are discussed below. The pellet fraction (41pel) may contain some polysomes in addition to being enriched for nuclei. In spite of the similarity to 41P (Table 2, line P) there do exist 41pel specific sequences, and these are discussed below.

*Comparison between 10R and 24P RNA.* This comparison (Table 2, line Q) was carried out to determine whether nonpolysomal sequences at stage 10 tend to become polysomal at stage 24. There is no such

tendency in the general population. Although much of the difference between 10R and 24P is due to stage 41 library clones detected by the 24P probe, differences specific to both 10R and 24P probes are found among the stage 10 library clones as well (Table 3, line F).

*Ontogeny of Individual Cloned Sequences*

On the basis of hybridization patterns such as those shown in Figs. 1-3 the developmental history of individual RNA sequences can be derived. Figure 4 presents

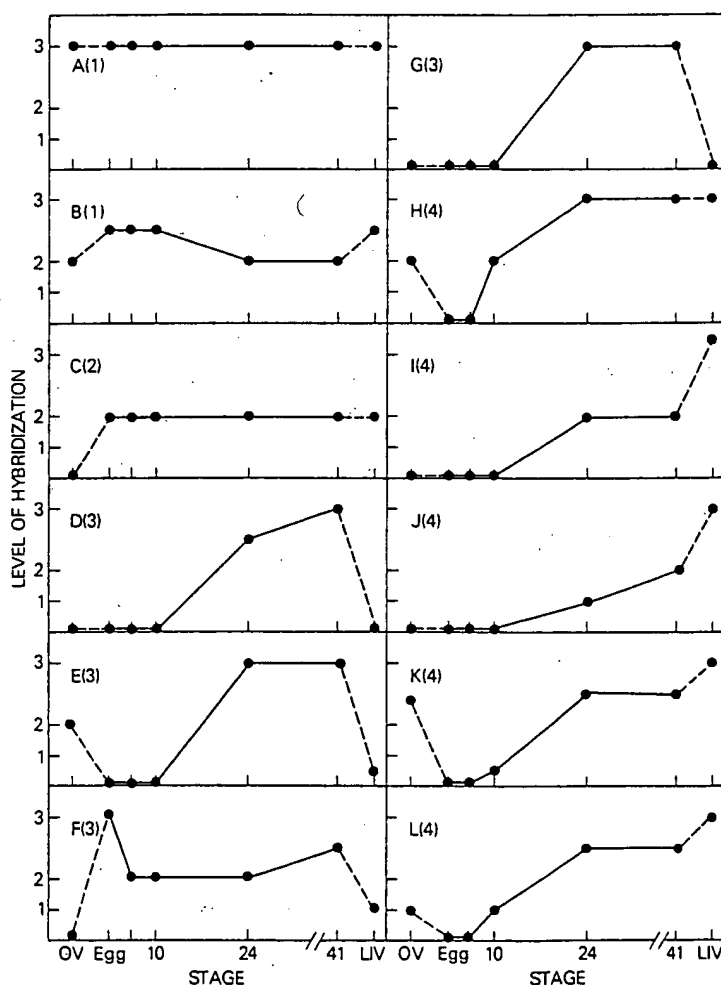

FIG. 4. Developmental history of 12 cloned sequences that are highly abundant in some RNA populations. The hybridization levels with various [<sup>32</sup>P]cDNAs are shown on a developmental time scale; responses to Ov and Liv probes are also shown. The abscissa shows the stage from which the probe was prepared and its length is proportional to time of development from egg to stage 24. The response with cleavage stage probe (stages 3-7) is shown between egg and stage 10. Four patterns of developmental history are indicated in parentheses and are described in the text. The clones shown are: (A) A11, C18, E19; (B) C5, E20, H13; (C) E21; (D) A3, D1; (E) A4; (F) C14; (G) E5, H2, H8; (H) D6, G17; (I) D21; (J) E12; (K) G27; (L) H9. In each case where several clones are listed together these represent cross-hybridizing sequences (see preceding paper) that were tested individually and responded in the same way. Responses to total poly(A)<sup>+</sup>RNA are shown.

such histories for 12 cloned sequences which are prominent in the RNA population of at least one stage of development. The developmental behavior of these sequences is quite variable, and they have been grouped somewhat arbitrarily into four patterns with distinct developmental properties.

Pattern (1) is exemplified by the sequences in panels A and B of Fig. 4. The RNAs corresponding to these clones are abundant in all stages studied and show only small variations in abundance. While the sequence of panel A appears constant through development, it must be remembered that hybridization at level 3 is open-ended and thus some variation probably occurs. Pattern (2), as shown by the sequence of panel C, is moderately abundant in all stages except ovary. Its undetectability in ovary RNA distinguishes this sequence from those of pattern (1).

Pattern (3) (panels D through G of Fig. 4) is characterized by changing abundance in embryonic development and low abundance in liver. Most of the sequences in this group have low representation in early development and increase dramatically between gastrula (stage 10) and tailbud (stage 24). Pattern (4) RNAs again show variability during embryogenesis, usually an increase with time, but are distinguished from pattern (3) RNAs by their abundance in adult liver. It is possible that some of these

RNAs are specifically involved with liver differentiation.

In general the 12 abundant sequences represented in Fig. 4 are either quite abundant throughout development or start from a low level in the egg and cleavage stage and proceed to increase substantially in later embryogenesis. This general pattern has already been apparent from the data in Tables 2 and 3 which showed that there are many more abundant RNA species in stage 41 tadpoles than in the egg and in stage 10 gastrulae.

*Intracellular distribution of two species of highly abundant RNA.* The clones described in Figs. 4A and B are of particular interest because they contain sequences present at such high levels in stage 10 poly(A)<sup>+</sup>RNA that they are represented by several clones in the stage 10 library (see Table 2 in the preceding paper). The sequence of Fig. 4A is present in the group of homologous clones A11, C18, E19, and clones D22 and E22 which cross-hybridize with the former three clones but show lower hybridization levels with cDNA probes (preceding paper). RNA homologous to this group of clones (Fig. 5A) is very abundant in the egg, in all cell fractions of stage 10, and in total stage 41 RNA, as can be seen in Figs. 1-3. The RNA of this sequence is also present in stage 41 polysomes, but is less abundant there. It is the most prominent sequence in 41pel RNA, which is a

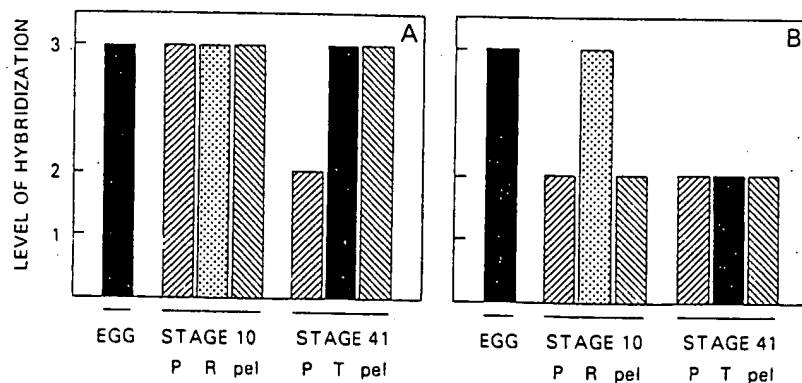

FIG. 5. Hybridization profiles of two very abundant sequences. The levels of hybridization of clones containing cross-hybridizing sequences and represented five times (A) or two times (B) among the 240 stage 10 clones tested (Table 2, preceding paper) are shown for [<sup>32</sup>P]cDNA probes prepared from egg, 10P, 10R, 10pel, 41P, 41T, and 41pel. (A) A11, C18, E19; (B) C5, E20, H13.

sample enriched for nuclei. This RNA class therefore appears to be highly abundant in different cell fractions and at various stages of development.

The RNA represented in Fig. 4B also shows high abundance in the egg (Fig. 5B). It is highly abundant in the nonpolysomal cytoplasmic fraction of stage 10 embryos and occurs at moderate abundance in the other fractions at this stage and in stage 41. These data, together with the wide representation of this sequence at different stages (Fig. 4B), show that the RNA of Fig. 5B is a widely distributed abundant species.

*Analysis of groups of clones containing polysomal and nonpolysomal sequences.* Clones were organized into groups depending on their preferential or exclusive hybridization with polysomal or nonpolysomal RNA sequences at different stages. Six such groups are defined in Table 4, and the number of clones in each group is listed.

The groups are defined to include either clones responding more strongly to the RNA from one cell fraction than another (A, B, C, and E), or clones which are detectable with one RNA sample but undetectable with another (D and F).

Groups A and B in Table 4 contain predominantly polysomal and nonpolysomal sequences, respectively, from stage 10. The data show that the stage 10 polysomal sequences are highly represented in stage 24 and stage 41 polysomal RNA, while stage 10 nonpolysomal sequences are less represented in the late stage polysomes. A few of the stage 10 polysomal sequences are predominantly polysomal at stage 41 (i.e., they are in the 41P > 41T class), but none of the stage 10 nonpolysomal sequences is.

At stage 41 we define polysomal sequences in two ways: either by their higher response to polysomal RNA than to total RNA, 41P > 41T, or by their presence in

TABLE 4  
COMPARISON OF GROUPS OF CLONED SEQUENCES ACCORDING TO THEIR POLYSOMAL OR NONPOLYSOMAL DISTRIBUTION

Group <sup>a</sup>	Number of clones <sup>b</sup>	Detected in (%) <sup>c</sup>					Represented in (%) <sup>d</sup>			
		Egg	10P	10R	24P	41P	10P > 10R	10R > 10P	41P > 41T	41T > 41P
A 10P > 10R	16	38	(100)	6	93	69	(100)	(0)	13	0
B 10R > 10P	24	75	21	(100)	58	42	(0)	(100)	0	29
C 41P > 41T	16	6	12	6	100	(100)	13	0	(100)	(0)
D 41P(φpel)	10	20	30	30	100	(100)	20	0	10	0
E 41T > 41P	18	45	45	72	61	44	0	44	(0)	(100)
F 41pel(φP)	14	79	64	78	43	(0)	0	57	(0)	35

<sup>a</sup> Clones were catalogued in six groups based on the differential representation of their sequences in polysomal and nonpolysomal RNAs. The symbol > indicates clones that respond more strongly to one RNA preparation than the other. Thus, 10P > 10R includes all clones that show a stronger signal with 10P than with 10R including those undetectable with 10R. The symbol φ indicates clones which showed no autoradiographic signal with that particular preparation. For instance, 41P(φpel) includes all clones detected with 41P but not with 41pel. Groups A, C, and D contain clones with sequences which are predominantly polysomal. Groups B, E, and F contain clones with sequences which are predominantly nonpolysomal.

<sup>b</sup> The number of clones (among the 860 scored) that belong to the group.

<sup>c</sup> The percentage of clones in each group that is detectable at any level of hybridization with the [<sup>32</sup>P]cDNA shown. For example, 93% of the clones in the (10P > 10R) group are detected with 24P. Percentages in parentheses are 100 or 0 by definition.

<sup>d</sup> The percentage of clones in each group that also belongs to the group shown at the head of the column. For example, 57% of the clones in the 41pel(φP) group belong to the (10R > 10P) group. Percentages in parentheses are 100 or 0 by definition.

polysomal RNA and absence (at the detection limit) from pellet RNA, 41P( $\phi$ pel). Nonpolysomal sequences are defined in the reciprocal way. The predominantly polysomal sequences show 100% inclusion in 24P, while nonpolysomal sequences are much less represented. Stage 41 polysomal sequences are generally not abundant at stage 10, both in 10P and 10R, while stage 41 nonpolysomal sequences are highly represented, especially in 10R. This phenomenon is particularly clear when we consider inclusion in the class of stage 10 nonpolysomal sequences (10R > 10P). While about half of the nonpolysomal stage 41 sequences are included in this class, none of the 41P sequences is. Thus, clones which contain sequences which are predominantly nonpolysomal at stage 41 are enriched for sequences that are also nonpolysomal at stage 10. We have detected no sequences which are predominantly polysomal in either stage 10 or stage 41 poly(A)<sup>+</sup>RNA that are predominantly nonpolysomal in the other stage; likewise, there are no predominantly nonpolysomal sequences in either stage 10 or stage 41 which are predominantly polysomal in the other stage. We stress that these statements refer to predominance of an RNA sequence in one or another cell fraction. Many of these RNAs actually occur in both compartments but their concentration in one compartment is much higher than in the other.

The extent to which sequences in the 41pel( $\phi$ P) group of nonpolysomal clones are homologous to polysomal and nonpolysomal RNA from stage 10 is further illustrated in Fig. 6, where individual clones are identified. The figure shows all of the clones in the 41pel( $\phi$ P) class. All but one of the clones in this class hybridize more strongly with 10R probe than with 10P probe, or are undetectable at stage 10.

Six stage 10 clones which represent very abundant RNAs and show very different responses to 10P and 10R probe are analyzed in Fig. 7. Figure 7E shows a clone containing a prominent stage 10 polysomal sequence which is also predominantly polysomal at stage 41 and gives a strong signal with 24P probe as well. The other five clones contain predominantly nonpolysomal sequences at stage 10 and all show stronger hybridization with 41T probe than with 41P probe. Only one of these five cloned sequences (panel D) shows a level 2 hybridization with 24P, the others are lower. The high titer of a nonpolysomal stage 10 sequence that is predominantly in 41pel is shown in panel A. Five of the cloned sequences shown in Fig. 7 are also present at a high abundance in egg. One sequence (E), however, cannot be detected in egg and therefore may be synthesized or polyadenylated during the first 10 hr of development. This sequence is predominantly polysomal at stage 10.

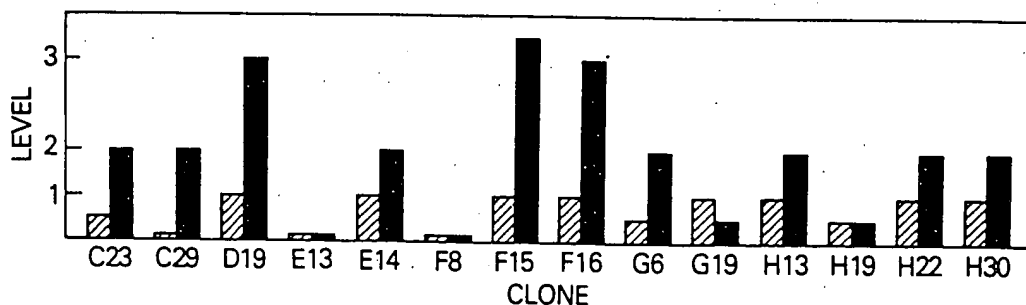

FIG. 6. Distribution of 41pel( $\phi$ P) clones in stage 10 poly(A)<sup>+</sup>RNA. The distribution in stage 10 of a class of nonpolysomal stage 41 clones detected in 41pel but undetectable in 41P [41pel( $\phi$ P), Table 4] is shown. The left bar (hatched pattern) shows the level of hybridization of each clone with 10P probe; the right bar (solid) shows the level of hybridization with 10R probe. Half-levels of response are estimated on the basis of multiple screens. Clone designation as in Figs. 1-3 is shown below each set of bars.

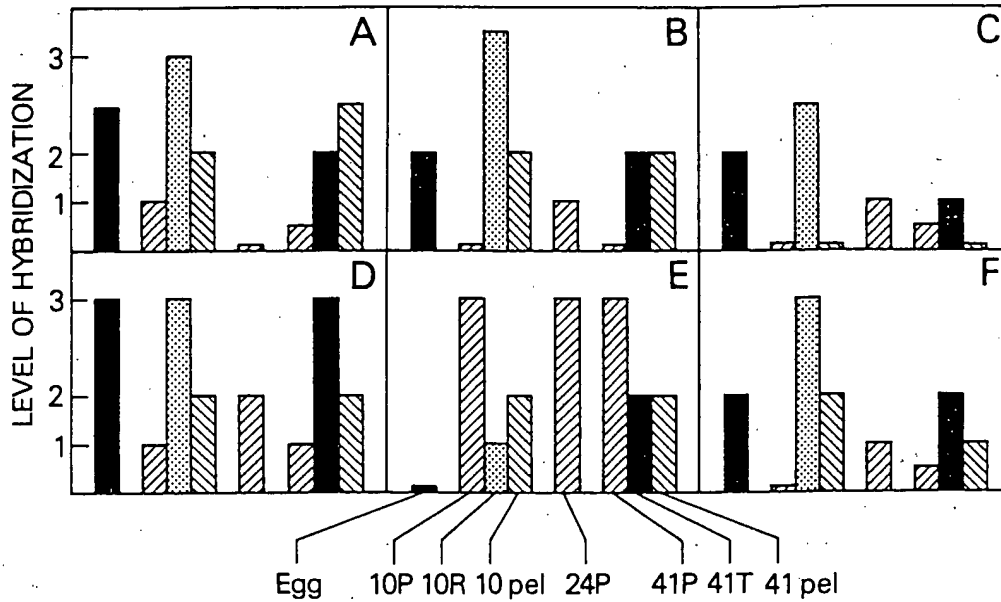

FIG. 7. Hybridization profiles of six stage 10 clones. Six (independent) stage 10 clones showed a level 3 hybridization with either 10P probe (one clone) or 10R probe (five clones) and a lower level of hybridization with the other. The levels of hybridization of these six clones are shown for eight different [<sup>32</sup>P]cDNA probes prepared from egg, 10P, 10R, 10pel, 24P, 41P, 41T, and 41pel. (A) D19; (B) F15; (C) H21; (D) C14; (E) D6, G17; (F) D15.

#### DISCUSSION

In this work we have sought to isolate by cloning probes for discrete abundant poly(A)<sup>+</sup>RNA species and to estimate the relative concentration of these sequences in various RNA populations. We have isolated over 200 such probes. Using colony hybridization we have catalogued each cloned sequence by its level of hybridization with [<sup>32</sup>P]cDNA prepared from 13 different poly(A)<sup>+</sup>RNA preparations. Quantitation by colony hybridization is not precise but reconstruction experiments allowed us to assign autoradiographic signals at three levels which correspond to concentrations between 0.06% and over 1% of the hybridizing cDNA in the total cDNA population (Dworkin and Dawid, 1980). From this cataloguing we can determine trends among the 200 clones we have studied, and can isolate those clones with patterns of hybridization that are particularly interesting for further study. A similar approach has been used by Williams and Lloyd (1979) to study RNA populations during the development of the slime mold *Dictyostelium discoideum*.

#### Developmental Patterns of Abundant Poly(A)<sup>+</sup>RNA Species

The hybridization patterns shown in Figs. 2 and 3 reveal great dissimilarity between mature egg and total ovary. Our results show that the class of abundant poly(A)<sup>+</sup>RNA in ovary is quite complex with few outstanding members. This is consistent with hybridization kinetics of ovary poly(A)<sup>+</sup>RNA (Perlman and Rosbash, 1978). A large number of the cloned sequences present at high abundance in egg are not even detectable in total ovary (Table 3, line A). The egg likely accumulates a specific subset of ovarian sequences that may be required for early development. However, our ovary preparation includes cells other than oocytes which may be partially responsible for the differences we find between total ovary and mature egg.

The high similarity between egg and 10T poly(A)<sup>+</sup>RNA (Table 2, line D) implies that little RNA synthesis is needed between fertilization and the beginning of gastrulation to account for the hybridization patterns we find. That is, the approximate levels of most abundant poly(A)<sup>+</sup>RNA species do



not change very much in concentration during the first 10 hr of development. This result is consistent with earlier experiments in many species indicating that transcription is not necessary for the egg to reach gastrula (reviewed in Davidson (1976)). Recently, Brock and Reeves (1978) and Bravo and Knowland (1979) using two-dimensional gel electrophoresis observed considerable changes in proteins synthesized *in vivo* by *Xenopus* embryos during this time. The proteins that they have detected are expected to be synthesized to a large extent on messages of the abundance class which we have analyzed. The constancy we find in abundant poly(A)<sup>+</sup>RNA species and the changes they show in protein synthetic patterns may reflect translational level control of protein synthesis during the cleavage stages. However, we do detect some differences in the abundant RNAs between egg and stage 10; in particular, there is one clone (Fig. 7E) that gives a very intense signal with stage 10 polysomal probe that we cannot detect with egg probe. This sequence may be heavily transcribed during the first 10 hr of development, or may be present but lack poly(A) in the unfertilized egg.

We find a dramatic change in hybridization patterns between stages 10 and 24 (between 10 and 32 hr of development), and then little change between stages 24 and 41. For the most part abundant stage 10 sequences are a subset of abundant stage 41 sequences, but are present at much higher concentration in stage 10. Thus, stage 10 probes react with fewer clones, but many of these clones react very strongly. Sets of clones containing the same sequences occur in the stage 10 library (Dworkin and Dawid, 1980). By stage 24 the abundant poly(A)<sup>+</sup>RNA species are a more diverse group containing a large number of sequences that are below our level of detection in stage 10 poly(A)<sup>+</sup>RNA. This dramatic change in abundant poly(A)<sup>+</sup>RNA species between 10 and 22 hr of development correlates well with studies by two-

dimensional gel electrophoresis of newly synthesized proteins during development in *X. laevis* (Brock and Reeves, 1978). These gel patterns show changing arrays of protein spots during early development with the greatest degree of pattern change occurring between the gastrula (stages 9-13) and neurula (stages 15-21), with little change after neurula for at least 24 hr.

#### *Relationship among Polysomal and Non-polysomal Poly(A)<sup>+</sup>RNA Populations during Development*

We have determined by [<sup>3</sup>H]poly(U) hybridization that 25-30% of the stage 10 cytoplasmic poly(A)<sup>+</sup>RNA is nonpolysomal free RNP, whereas very little of the cytoplasmic stage 41 poly(A)<sup>+</sup>RNA is. This change in the cytoplasmic distribution of nonribosomal RNA during early development is similar to changes reported in echinoderms (Dworkin and Infante, 1976), and agrees with the mobilization of stored ribosomes into polysomes in *Xenopus* (Woodland, 1974). We have not, however, clearly distinguished nonpolysomal cytoplasmic RNA from abundant nuclear RNA sequences. This is because only polysomal preparations could be highly purified while the other cell fractions in our experiments are not well characterized. We have defined and compared two groups of nonpolysomal RNA preparations. In stage 10 embryos we have prepared postribosomal free RNPs, which may contain nuclear RNA derived from lysed nuclei, but are unlikely to be contaminated by polysomal RNA. For stage 41 we have considered 15,000g pellet sequences which cannot be detected in polysomes as nonpolysomal RNA; these sequences are most likely nuclear. We have also considered sequences that are more prominent in total stage 41 embryos than in stage 41 polysomes as being nonpolysomal. Using the 41T probe we detected sequences in addition to those found with 41P or 41pel probes.

Many abundant sequences in stage 10 embryos were detected in both the poly-

somal and free RNP populations, though often at different concentrations. Of the two most abundant stage 10 sequences, one is distributed rather equally between polysomes and free RNP while the other predominates in free RNP (Fig. 5). Several other cloned sequences strongly predominate in one population or the other (Table 4, Fig. 7). We have asked whether predominantly nonpolysomal sequences of stage 10 are recruited into polysomes at a later stage. While many of the prominent nonpolysomal sequences from stage 10 are detectable in stage 24 polysomes (Table 4), they occur at a low concentration in that stage. In addition, many new sequences, not detected at all in stage 10 RNA, appear in polysomal RNA at stage 24 (Table 2). Likewise, some nonpolysomal stage 10 sequences appear in stage 41 polysomes but none predominates in that population (Table 4). What is more striking is the overlap of clones containing nonpolysomal sequences from stages 10 and 41. Predominantly nonpolysomal sequences from stages 10 and 41 show greater overlap with each other than predominantly polysomal sequences from these two stages. This was surprising. We thus suggest that while nonpolysomal sequences in embryos may be utilized by the translational apparatus later in development, they are still likely to be (but not necessarily) nonpolysomal at any stage at which they are present.

It is clear, however, that after fertilization there is a major shift of messenger RNA from the postribosomal compartment to the polysomes (reviewed in Davidson (1976)). This general recruitment of nonpolysomal sequences into polysomes may be a particular feature of the first several hours following fertilization and not a general mechanism of regulation during later development. Our data are consistent with models for gene regulation in other systems where free RNP particles are thought to be enriched for messages intrinsically inefficient in initiation of translation (Lodish, 1974; Dworkin *et al.*, 1977; Rudensey and

Infante, 1979). Alternatively, some of these RNA species may not be messengers.

#### *Isolation of Cloned Probes for Further Study*

The data presented in this paper provide the necessary background for the selection of a smaller number of clones for more detailed quantitative study of developmental behavior. Some clones may appear particularly interesting for further study, e.g., the clone that contains a sequence which is undetectable in egg RNA but abundant in gastrula (Fig. 7E) or the very abundant stage 10 sequence which is enriched in the pellet fraction in stage 41 (Fig. 5A). However, without having to judge what is "interesting" the present data are a valuable guide in that they illustrate the types of developmental behavior that occur among abundant RNAs and allow selection of representative examples from the various classes for further study. The advantages of a screening of this type are limited, however, to the most abundant RNA molecules. For any RNA below our detection limit, which includes over half of the mass of the RNA and the vast majority of the sequence complexity, we have no information except that a particular cloned sequence does belong to that lower abundance class.

We thank Dr. J. W. Beard for reverse transcriptase, and Eric Davidson, Brian Kay, Eric Long, Eva Rastl, Michael Rosbash, Maxine Singer, and Walter Wahli for useful comments on the manuscript. We thank Ronald Thayer for making his colony hybridization procedure available to us prior to publication.

#### REFERENCES

- BISHOP, J. O., and ROSBASH, M. (1974). Polynucleotide sequences in eukaryotic DNA and RNA that form ribonuclease-resistant complexes with polyuridylic acid. *J. Mol. Biol.* 85, 75-86.
- GLOBEL, G. (1971). Release, identification, and isolation of messenger RNA from mammalian ribosomes. *Proc. Nat. Acad. Sci. USA* 68, 832-835.
- BRAVO, R., and KNOWLAND, J. (1979). Classes of proteins synthesized in oocytes, eggs, embryos, and differentiated tissues of *Xenopus laevis*. *Differentiation* 13, 101-108.
- BROCK, H. W., and REEVES, R. (1978). An investiga-

- tion of *de novo* protein synthesis in the South African clawed frog, *Xenopus laevis*. *Develop. Biol.* 66, 128-141.
- DAVIDSON, E. H. (1976). "Gene Activity in Early Development," 2nd ed. Academic Press, New York.
- DWORKIN, M. B., and DAWID, I. B. (1980). Construction of a cloned library of expressed embryonic gene sequences from *Xenopus laevis*. *Develop. Biol.* 76, 435-448.
- DWORKIN, M. B., and INFANTE, A. A. (1976). Relationship between the mRNA of polysomes and free ribonucleoprotein particles in the early sea urchin embryo. *Develop. Biol.* 53, 73-90.
- DWORKIN, M. B., RUDENSEY, L., and INFANTE, A. A. (1977). Cytoplasmic nonpolysomal ribonucleoprotein particles in sea urchin embryos and their relationship to protein synthesis. *Proc. Nat. Acad. Sci. USA* 74, 2231-2235.
- GRUNSTEIN, H., and HOGNESS, D. S. (1975). Colony hybridization: A method for the isolation of cloned DNAs that contain a specific gene. *Proc. Nat. Acad. Sci. USA* 72, 3961-3965.
- MILLER, L. (1978). Relative amounts of newly synthesized poly(A)<sup>+</sup> and poly(A)<sup>-</sup> messenger RNA during development of *Xenopus laevis*. *Develop. Biol.* 64, 118-129.
- NIEUWKOOP, P., and FABER, J. (1967). "Normal Table of *Xenopus laevis* (Daudin)," 2nd ed. North-Holland, Amsterdam.
- PALACIOS, R., PALMITER, R. D., and SCHIMKE, R. T. (1972). Identification and isolation of ovalbumin synthesizing polysomes. *J. Biol. Chem.* 247, 2316-2321.
- RUDENSEY, L. M., and INFANTE, A. A. (1979). Translational efficiency of cytoplasmic nonpolysomal messenger Ribonucleic Acid from sea urchin embryos. *Biochemistry* 18, 3056-3063.
- THAYER, R. E. (1979). An improved method for detecting foreign DNA in plasmids of *Escherichia coli*. *Anal. Biochem.* 98, 60-63.
- WILLIAMS, J. G., and LLOYD, M. M. (1979). Changes in the abundance of polyadenylated RNA during slime mold development measured using cloned molecular hybridization probes. *J. Mol. Biol.* 129, 19-35.
- WOODLAND, H. R. (1974). Changes in the polysome content of developing *Xenopus laevis* embryos. *Develop. Biol.* 40, 90-101.