

[72] Inventors **Don P. Metzgar;**
James V. Sorrentino, Stroudsburg, Pa.
 [21] Appl. No. **797,822**
 [22] Filed **Feb. 10, 1969**
 [45] Patented **Mar. 30, 1971**
 [73] Assignee **Richardson-Merrell Inc.**
New York, N.Y.

2,281,617 5/1942 Ramsdell..... 206/1UX
 3,432,275 3/1969 Unger..... 350/95
Primary Examiner—David Schonberg
Assistant Examiner—T. H. Kusmer
Attorney—Harvey W. Edelblute

[54] **MULTIPLE WELL TISSUE CULTURE SLIDE**
5 Claims, 3 Drawing Figs.

[52] U.S. Cl..... **350/95,**
 356/244
 [51] Int. Cl..... **G02b 21/34**
 [50] Field of Search..... 350/92-
 —95; 356/244; 206/1 (t); 220/20, 22

[56] **References Cited**
UNITED STATES PATENTS
 1,516,896 11/1924 Turner 356/244
 2,302,830 11/1942 Axelrad..... 350/95
 3,031,924 5/1962 Lamal 350/95

ABSTRACT: A tissue culture microscope slide comprising a transparent flat plate having depressions or wells on the top surface thereof. The walls defining each well have an opening extending from the top to the bottom of the well adjacent to an edge of the plate to facilitate the drainage of liquids therefrom. The bottom surface of each well is substantially parallel with the bottom surface of the plate. The tissue culture slide after preparation with fixed, confluent, viral infected tissue culture cells can be used with fluorescent labeled reagents and a fluorescent microscope to provide the technologist or clinician with a tool for rapidly screening the sera of patients or animals for a variety of viral agents as measured by the presence in the patients' or animals' serum of antibody against a specific viral agent.

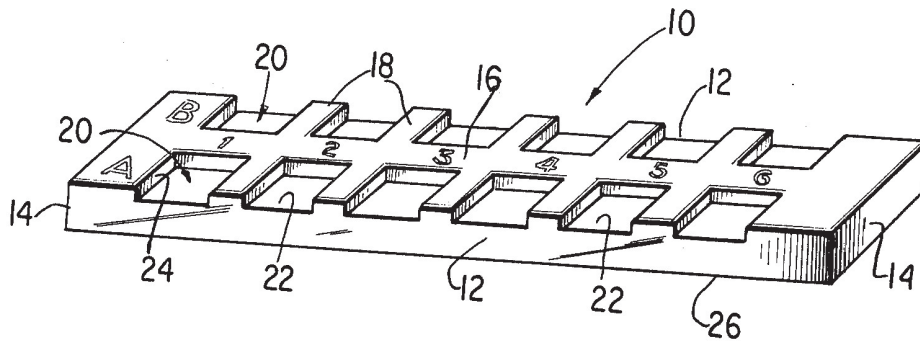

FIG. 1

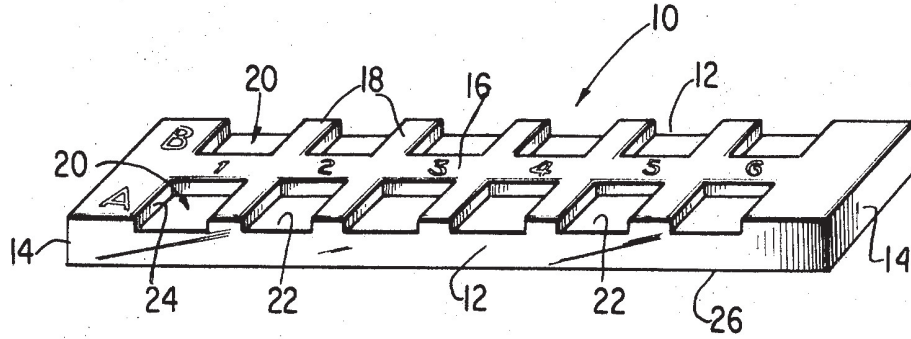

FIG. 2

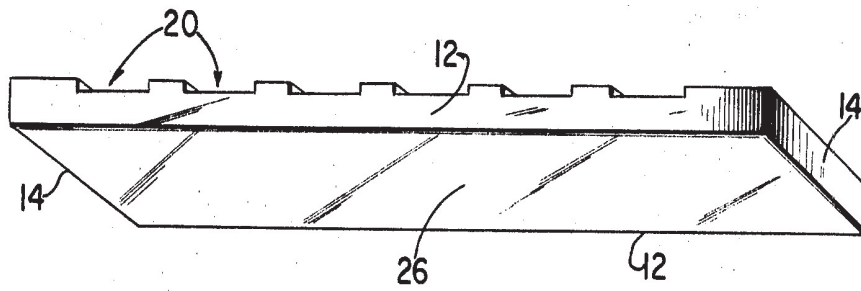
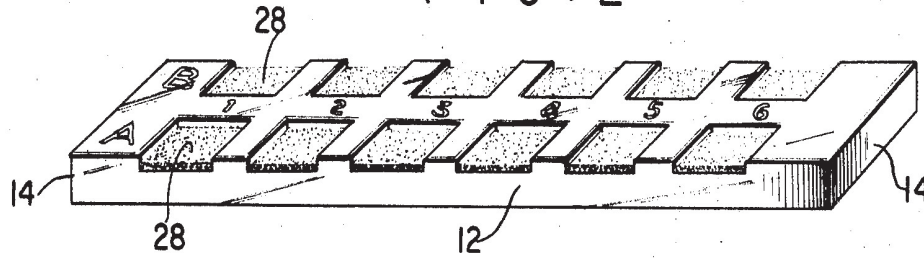

FIG. 3

INVENTORS
DON P. METZGAR
JAMES V. SORRENTINO
BY *George P. Markas*

MULTIPLE WELL TISSUE CULTURE SLIDE

This invention relates to a multiple well tissue culture slide. More particularly, this invention relates to a multiple well tissue culture microscope slide and to such a slide having fixed, confluent, viral infected tissue culture cells which can be used for the rapid diagnosis of viral diseases using fluorescent antibody technique.

The use of fluorescent antibody technique for the detection and identification of viruses as well as bacteria, while highly reliable, requires a considerable amount of time and effort to prepare the reagents and the tissue required for the test. Broadly, such tests are carried out by the following procedure. Tissue culture cells of the required type and species are placed on a culture surface or vessel such as that of a Petri dish, microscope slide or microscope coverslip. After a sufficient period of incubation in which the cells become attached to the culture surface, the cells are infected with a specific virus agent. After another period of incubation, during which the virus agent multiplies, the culture vessel is removed from the incubator, the cells are fixed with a suitable fixative and then dried. This then becomes the basic unit for the fluorescent antibody technique as generally practiced in the prior art. The fixed, infected tissue culture vessels are prepared in multiples. If serum dilutions are to be used a separate Petri dish, microscope slide or coverslip culture must be prepared for each dilution. If more than one serum sample is to be used, this requires multiples of the culture. Each culture is then treated with a dilution of the patient's or animal's serum. The serum is allowed to remain in contact with the culture for 15 to 30 minutes. It is then rinsed in a suitable diluent to remove the excess serum. The culture is then treated for 15 to 30 minutes with a fluorescein conjugated homologous antiserum. Usually this antiserum is gamma globulin common to the species being tested. Each culture is rinsed to remove the excess fluorescein conjugate and then dried.

After drying, the culture is examined microscopically, with a fluorescent microscope. A positive diagnosis is indicated by the presence of specific fluorescence in the treated culture.

The use of the above-described fluorescent technique is well known. It is described by (a) Coons, A. H., *International Rev. Cytol.* 5:1-23, 1956; (b) Coons, A. H., *In General Cytological Methods*, New York Academic Press, 1958, Volume I; (c) Liu, C., *Ergebn. Mikrob. Immunforsch.* 33:242, 1960; and (d) *Fluorescent Antibody Techniques*, Public Health Service Publication No. 729 (1966) U.S. Gov't Printing Office.

Although the fluorescent antibody technique has many advantages, it can be a time-consuming and laborious procedure. Thus, a test requiring 6 serum dilutions requires a total of 12 different Petri dishes, microscope coverslip or microscope slide cultures. Each one must be prepared, treated, rinsed, dried and examined separately.

It is a primary object of this invention to provide a multiple well tissue culture microscope slide which is easy to use and which decreases the time and manipulative steps required for performing the diagnosis of viral disease using fluorescent antibody technique.

It is another object of this invention to provide such a tissue culture slide in which the wells contain a fixed, confluent sheet of cells infected with virus. Such a slide can be supplied to a technologist or clinician performing antiviral tests, and thus further decrease the time and manipulative steps required for making tests on patients or animals.

Other objects will appear from the description hereinafter.

Briefly, the multiple well tissue culture slide of this invention comprises a transparent flat plate having depressions or wells on the top surface thereof. The walls defining each of the wells have an opening extending from the top to the bottom of the well adjacent to an edge of the plate in order to facilitate the drainage of liquids therefrom. The bottom surface of the plate is substantially flat and preferably the bottom surface of each well is also flat and substantially parallel with the bottom surface of the plate.

The use of this invention makes available, in one single slide, all of the basic materials required to perform the fluorescent antibody technique. This invention can reduce the total time required for such diagnostic tests, including the preparative work, from 7 to 14 days to a maximum time of 2 hours. With the multiple well tissue culture slide of this invention, an entire test requiring 6 or even more dilutions can be performed on a single slide. This eliminates the processing of multiple cultures and the necessity of individual microscopic examination of many cultures. The multiple well slide can be examined in one microscopic manipulation.

Any virus agent that can be grown in tissue culture can be adapted to use with this invention. By making available a kit containing slides having a series of fixed cells infected with a virus or group of viruses, the physician, laboratory or institution will have available a rapid and specific tool to be used in diagnosis of diseases of virus etiology.

Referring now to the drawings, wherein identical numerals refer to identical parts:

FIG. 1 is a perspective view of the slide showing the top and sides thereof;

FIG. 2 is a perspective view of the slide of FIG. 1 showing the top and sides thereof with a confluent sheet of virus-infected tissue culture cells in each of the wells; and

FIG. 3 is a perspective view showing the bottom and sides of the slide of FIG. 1.

The microscope slide 10 is a rectangular plate of a flat piece of glass or other transparent material such as a synthetic resin, e.g., polystyrene. The slide 10 has two long sides or edges 12-12 parallel to each other; narrow sides or edges 14-14, at right angles to the long sides 12-12. Each side 12 is 90 millimeters (mm.) long. Each narrow side 14 has a width of 25 mm. A longitudinal rib 16 having a width of 5 mm. and transverse ribs 18 having a width of 2 mm. together with raised portions along the narrow sides 14-14 define square wells or depressions 20 therebetween. The top surfaces of ribs 16 and 18 and the raised portions along narrow sides 14-14 are in the same plane and parallel to slide bottom 26. The thickness of the slide from the top surfaces of the ribs to the bottom surface 26 thereof is 1 mm. Walls 24 enclose three sides of each well 20. These wells are 0.5 mm. deep and each well wall 24 has a length of 10 mm. Wells 20 are open, from the bottom to the bottom thereof, adjacent their respective edge 12. The bottom 26 of the microscope slide 10 is flat and parallel with the bottom 22 of each of the wells 20. In FIG. 2 each of the wells 20 contains a fixed fluent virus-infected tissue culture 28 attached to the bottom surface 22 thereof. The narrow ends 14-14 form walls, 10 mm. wide, for one side of the wells at each end of the slide. The slide has designators A and B for indicating each row of wells 22 and additionally has numerical designators 1-6 on ribs 16 between opposed wells so that the use of the letter and numerical designators can define each of the wells.

The following examples serve to further illustrate this invention.

EXAMPLE 1

This example shows the use of the multiple well tissue culture slide of FIG. 1.

A. A single multiple well slide, as shown in FIG. 1, is prepared for the patient's serum to be examined. The slide is completely immersed in a culture vessel containing nutrient medium for the cells to be used. In this case human Wi-38 diploid cells were used. Wi-38 cells are added to the medium covering the slide. After a stationary incubation period of 4 to 5 days at 35° C. to 37° C. the multiple well culture is infected by adding an inoculum of adenovirus type 3 to the culture medium.

B. The virus infected multiple well slide is removed from the nutrient medium and fixed with acetone for 10 minutes and then dried. The culture is attached to all the surfaces of the plate. The culture is wiped off of the plate, except for that in

the bottom of the wells 22 as appears as 28 in FIG. 2. Each of the wells now contain a fixed confluent sheet of Wi-38 cells infected with adenovirus type 3.

C. Serum is withdrawn from the convalescing patient wherein adenovirus type 3 is suspected as a cause of the illness. Dilutions of the patient's serum are prepared and each well is covered with about 0.1 milliliter of a single dilution. One row of wells, e.g., Row A of FIG. 2, containing the control serum (normal serum) dilutions and one row, e.g., Row B of FIG. 2, of wells containing the patient's serum, are prepared. Dilutions are prepared in two-fold serial dilutions of 1:2, 4, 8, 16 and 32.

D. The multiple well culture is then placed in a moist chamber for 15 to 30 minutes at 35° C. to 37° C. and then rinsed with 0.02 Molar phosphate buffered saline solution at pH 7.2 to remove the excess serum.

E. Each well is then overlaid with a fluorescein labeled conjugated antiserum for the gamma globulin contained in the patient's serum. Such labeled conjugated antiserum is available commercially. This antiserum is absorbed on the confluent film in a moist chamber for 30 minutes at 35° C. to 37° C. and rinsed as above with the phosphate buffer.

F. The multiple well culture is then examined microscopically in a fluorescent microscope, for the presence of specific fluorescence. If positive, the preparation will fluoresce green, if negative, no fluorescence will be seen, as in the case of the normal serum controls.

The above test is carried out with a single slide and is observed microscopically in a single operation. The normal serum and suspected serum are side by side, allowing for simultaneous observation.

EXAMPLE 2

This example shows a test to determine the presence of adenovirus antibody in a patient's serum.

A kit containing 8 slides such as shown in FIG. 2 is supplied to the physician or laboratory. Each slide has a confluent cell tissue culture infected with a different adenovirus type which has been fixed, as described in Example 1, paragraphs A and B. In this instance, however, the adenovirus is that of types 1, 2, 5, 3, 4, 7, 14 and 21. The physician treats each slide with the human suspected serum and with the normal serum as described in paragraph C of Example 1 and, by following the remaining procedure of Example 1, can determine within about 2 hours if one of the adenovirus types being screened was involved in the patient's illness.

Although the present invention has been described in conjunction with a preferred embodiment, it is to be understood that modifications and variations may be resorted to without departing from the spirit and scope of the invention, as those skilled in the art will readily understand. Thus, it will be observed that in place of diagnosing for viral antibodies, the novel slide of this invention may be used for other diagnostic tests with a fluorescent microscope, such as, for instance, in diagnosing for bacterial illness. Such variations and modifica-

tions are considered to be within the purview and scope of the appended claims.

We claim:

1. A multiple well tissue culture microscope slide comprising:

- a. a flat plate of transparent material;
- b. a plurality of wells or depressions on the top surface of the plate;
- c. said wells having an opening on one side thereof adjacent an edge of said plate, said opening extending from top to bottom of the well to facilitate drainage of liquids therefrom; and wherein
- d. the bottom surface of said plate opposite each well is flat.

2. A multiple well tissue culture microscope slide comprising:

- a. a flat plate of transparent material;
- b. a series of depressions or wells spaced from each other on the top surface of said plate;
- c. the bottoms of said depressions being flat and in a plane parallel with the bottom of the slide;
- d. each of said depressions defined by sidewalls and a bottom;
- e. said sidewalls having an opening adjacent one of the plate edges, said opening extending from the top to the bottom of said wells to facilitate drainage of liquids therefrom.

3. A multiple well tissue culture microscope slide comprising:

- a. a flat plate of transparent material;
- b. ribs projecting upwardly on the top surface of said plate as an integral part thereof defining a series of wells spaced from each other;
- c. said ribs enclosing a major portion of the wells and having an opening extending from the top to the bottom of the wells adjacent a plate edge to permit fluid communication between the well and said plate edge to facilitate drainage of liquids therefrom; and
- d. wherein the bottom surface of said wells is substantially flat and parallel to the bottom surface of said plate.

4. A multiple well tissue culture microscope slide comprising:

- a. a transparent, flat rectangular plate;
- b. a first row of depressions or wells on the top surface of said plate adjacent one of the plate long sides;
- c. a second row of depressions or wells on the top surface of said plate adjacent the other long side of the plate;
- d. the bottom surface of the wells being substantially flat and parallel with the plate bottom; and
- e. each row of wells having an opening extending from the bottom surface thereof to the top facing the adjacent plate edge, said openings facilitating the drainage of fluid out of said wells.

5. A multiple well tissue culture slide of claim 4 having attached to the bottom surface of said wells a fixed, confluent sheet of cells infected with virus.

60

65

70

75

PO-1050
(5/69)

UNITED STATES PATENT OFFICE
CERTIFICATE OF CORRECTION

Patent No. 3,572,892 Dated March 30, 1971

Inventor(s) Don P. Metzgar and James V. Sorrentino

It is certified that error appears in the above-identified patent and that said Letters Patent are hereby corrected as shown below:

Column 2, line 44, "bottom" should read --top--; column 2, line 48, "fluent" should read --confluent--;

Signed and sealed this 5th day of December 1972.

(SEAL)
Attest:

EDWARD M. FLETCHER, JR.
Attesting Officer

ROBERT GOTTSCHALK
Commissioner of Patent