

Trials@uspto.gov
571.272.7822

Paper No. 8
Filed: Sept. 20, 2016

UNITED STATES PATENT AND TRADEMARK OFFICE

BEFORE THE PATENT TRIAL AND APPEAL BOARD

APPLE INC.,
Petitioner,

v.

PERSONALIZED MEDIA COMMUNICATIONS LLC,
Patent Owner.

Case IPR2016-00753
Patent 7,752,649 B1

Before KARL D. EASTHOM, TRENTON A. WARD, and
GEORGIANNA W. BRADEN, *Administrative Patent Judges*.

BRADEN, *Administrative Patent Judge*.

DECISION
Institution of *Inter Partes* Review
37 C.F.R. § 42.108

I. INTRODUCTION

A. Background

Apple Inc. (“Petitioner”) filed a Petition (Paper 1, “Pet.”) to institute an *inter partes* review of claims 39, 54, 62, and 67 of U.S. Patent No. 7,752,649 B1 (Ex. 1002, “the ’649 patent”). Personalized Media Communications LLC (“Patent Owner”) filed a Preliminary Response (Paper 7, “Prelim. Resp.”). We have jurisdiction under 35 U.S.C. § 314(a), which provides that an *inter partes* review may not be instituted “unless . . . there is a reasonable likelihood that the petitioner would prevail with respect to at least 1 of the claims challenged in the petition.”

Upon consideration of the Petition, Petitioner’s cited evidence, Patent Owner’s Preliminary Response and associated evidence, we conclude Petitioner has established a reasonable likelihood it would prevail with respect to at least one of the challenged claims. Accordingly, for the reasons that follow, we institute an *inter partes* review.

B. Related Proceedings

Petitioner informs us that the ’649 patent is the subject of a lawsuit: *Personalized Media Commc’ns, LLC v. Apple, Inc.*, No. 2:15-cv-01366-JRG-RSP (E.D. Tex., filed July 30, 2015). Pet. 59. Petitioner also informs us that other patents related to the ’649 patent are the subject of instituted *inter partes* review proceedings. *Id.*; see IPR2014-01527, IPR2014-01528, IPR2014-01530, IPR2014-01531, IPR2014-01532, IPR2014-01533, and IPR2014-01534.

Patent Owner informs us that the ’649 patent is the subject of the following additional lawsuits: *Personalized Media Commc’ns, LLC v. Funai Electric Co.*, No. 2:16-cv-00105 (E.D. Tex., filed February 1, 2016);

IPR2016-00753
Patent 7,752,649 B1

Personalized Media Commc'ns, LLC v. Top Victory Electronics (Taiwan) Co., No. 2:15-cv-1206-JRG-RSP (E.D. Tex., filed July 1, 2015); *LG Electronics, Inc. v. Personalized Media Commc'ns, LLC*, No. 1:15-cv-1096-RGA (D. Del., filed November 26, 2015); and *Personalized Media Commc'ns, LLC v. Samsung Electronics America, Inc.*, No. 2:15-cv-1754-JRG-RSP (E.D. Tex., filed November 10, 2015). Paper 4, 1.

C. The '649 Patent

The '649 patent discloses an apparatus and methods for the transmission, reception, processing and presentation of information carried on various types of electrical signals (i.e., standard radio and television signals). Ex. 1002, Abstr. According to the '649 patent, a subscriber station receives conventional television broadcast transmissions via a conventional antenna. *Id.* at 10:44–46. Digital information, including information that causes the receiver to perform particular functions, is embedded in the broadcast. *Id.* at 7:51–63, 23:34–37. A television monitor connected to the subscriber station presents received video and audio information. *Id.* at Fig. 1, 11:20–23. The '649 patent discloses that receiving a frequency of interest causes a TV signal decoder to receive and process command information from a first message. *Id.* at 130:9–12.

One embodiment of the '649 patent is shown in Figure 3A, reproduced below.

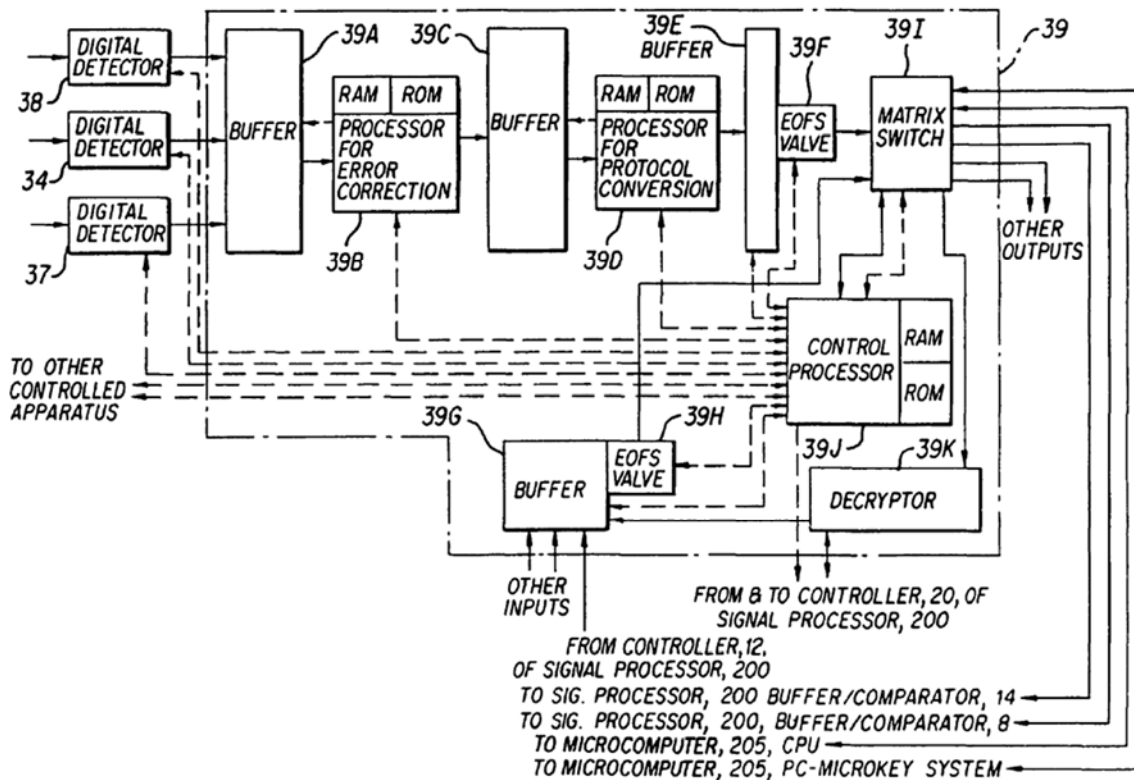

As shown in Figure 3A above, receiving information embedded in a signal causes the binary SPAM information of a first command, with error correcting information, to be detected at detector 34; checked and corrected, as necessary, at processor 39B; converted into locally usable binary information at processor 30, 39D; and recorded at the SPAM-input-signal memory of said control processor 39J. Ex. 1002, 130:25–31. The control apparatus of decoder 30 is preprogrammed to process information as monitor information and local control information. *Id.* at 130:31–33. Upon receipt of a first command, preprogrammed instructions at the RAM and ROM associated with control processor 39J cause control processor 39J to process the information of the command. *Id.* at 130:34–38. Control processor 39J then locates monitor 40 information that it retains in its RAM associated with the channel mark of cable channel 13 and compares the

“program unit identification code” of the first command with the program unit information of the monitor information in RAM. Ex. 1002, 130:38–45. No match results which indicates cable channel 13 is transmitting a new program unit. *Id.* at 130:44–45.

Not resulting in a match causes said controller 39 automatically to transfer information of new programming to microcomputer 205 and to transfer to buffer/comparator 14 for further processing said monitor information in RAM, which is monitor information of the programming transmitted on cable channel 13 prior to a program of interest. *Id.* at 130:45–51. Automatically, control processor 39J causes matrix switch 39I to cease transferring information from said EOFs valve 39F to control processor 39J and commence transferring information from control processor 39J to buffer/comparator 8 (to which said matrix switch 39I has capacity to transfer information). *Id.* at 130:51–56. Control processor 39J then automatically transmits a message that consists of binary information of a “00” header (indicating a command with execution and meter-monitor segments), the execution segment information of the pseudo command, a meter-monitor segment containing monitor information in RAM (including the associated channel mark and the format information of said information), and any padding bits required to end the message. *Id.* at 130:56–64, Fig. 2E.

Another embodiment of the ’649 patent is shown in Figure 2E, reproduced below.

Explore Litigation Insights

Docket Alarm provides insights to develop a more informed litigation strategy and the peace of mind of knowing you're on top of things.

Real-Time Litigation Alerts



Keep your litigation team up-to-date with **real-time alerts** and advanced team management tools built for the enterprise, all while greatly reducing PACER spend.

Our comprehensive service means we can handle Federal, State, and Administrative courts across the country.

Advanced Docket Research



With over 230 million records, Docket Alarm's cloud-native docket research platform finds what other services can't. Coverage includes Federal, State, plus PTAB, TTAB, ITC and NLRB decisions, all in one place.

Identify arguments that have been successful in the past with full text, pinpoint searching. Link to case law cited within any court document via Fastcase.

Analytics At Your Fingertips



Learn what happened the last time a particular judge, opposing counsel or company faced cases similar to yours.

Advanced out-of-the-box PTAB and TTAB analytics are always at your fingertips.

API

Docket Alarm offers a powerful API (application programming interface) to developers that want to integrate case filings into their apps.

LAW FIRMS

Build custom dashboards for your attorneys and clients with live data direct from the court.

Automate many repetitive legal tasks like conflict checks, document management, and marketing.

FINANCIAL INSTITUTIONS

Litigation and bankruptcy checks for companies and debtors.

E-DISCOVERY AND LEGAL VENDORS

Sync your system to PACER to automate legal marketing.