

⑫ 公開特許公報(A)

昭63-125984

⑬ Int. Cl. ⁴	識別記号	庁内整理番号	⑭ 公開 昭和63年(1988)5月30日
G 09 G 3/00		C-7335-5C	
B 61 L 25/02		A-7304-5H	
G 06 F 15/21		C-7230-5B	
G 08 G 1/12		6821-5H	
		6821-5H	
G 09 F 9/00	3 6 3	A-6866-5C	審査請求 未請求 発明の数 3 (全5頁)

⑮ 発明の名称 交通機関における情報表示システム

⑯ 特 願 昭61-272668

⑰ 出 願 昭61(1986)11月15日

⑱ 発 明 者 峯 崎 林 二 郎 東京都町田市小山町3947-56
 ⑲ 発 明 者 牛 久 久 男 東京都港区南青山7-5-14-201
 ⑳ 出 願 人 峰 崎 林 二 郎 東京都町田市小山町3947-56
 ㉑ 出 願 人 牛 久 久 男 東京都港区南青山7-5-14-201
 ㉒ 復 代 理 人 弁 理 士 和 田 成 則

要 約

1. 発明の名称 交通機関における情報表示システム

2. 特許請求の範囲

(1) ビデオディスプレイ装置により情報伝達表示部を形成し、該情報伝達表示部の指令装置は各駅に設置される制御部と、各制御部を統括する中央制御部に連結して情報表示システムを形成し、情報伝達表示部は駅内に設置されている乗車券自動販売機の一体的に組合せ構成してなることを特徴とする交通機関における情報表示システム。

(2) ビデオディスプレイ装置は、乗車券自動販売機の上部又は下部の何れかに一体的に組合せ構成してなる特許請求の範囲第1項記載の情報表示システム。

(3) ビデオディスプレイ装置は、乗車券自動販売機の左右部の何れか、又は、両方に一体的に組合

せ構成してなる特許請求の範囲第1項記載の情報表示システム。

(4) ビデオディスプレイ装置により情報伝達表示部を形成し、該情報伝達表示部の指令装置は各駅に設置される制御部と、各制御部を統括する中央制御部に連結して情報表示システムを形成し、情報伝達表示部は電車車内の吊るし広告部に形成してなることを特徴とする交通機関における情報表示システム。

(5) ビデオディスプレイ装置による情報伝達表示部は、電車車内の両側壁面の広告部である特許請求の範囲第4項記載の情報表示システム。

(6) ビデオディスプレイ装置により情報伝達表示部を形成し、該情報伝達表示部の指令装置は各駅に設置される制御部と、各制御部を統括する中央制御部に連結して情報表示システムを形成し、情報伝達表示部はホームに設置されている売店の裏

壁面に取付け構成してなることを特徴とする交通機関における情報表示システム。

3. 発明の詳細な説明

産業上の利用分野

本発明は、駅及び駅相互間或いは走行中の車両内において各種情報を選択的に多機能に情報表示をすることができる情報システムの提供、及び、その遠行指令装置の提供に関するものである。

従来技術

従来より、鉄道、バス或いは空港等の各駅において情報の提供は、ポスターやアナウンスにより行われることが多かった。

然し乍ら、アナウンスによる情報の提供は同時に多数の人に伝達し得るが、一過性であると共に特にこれらの場所柄騒音が多く聞き取りにくく、聞き損じが種々ある等の欠点があった。

また、ポスターなど視覚に訴える表示は、表示内容を逐次変化させることができず、内容を変更する場合には一々ポスターを換えなければならず

に割り込み独自の放映機能を有するよう構成してもよい。

情報伝達表示部Jは、静的映像のみならず動的映像を表示すべく、ブラウン管或いは液晶画面等によるビデオディスプレイ装置により形成する。

この情報伝達表示部Jの制御システムの1例を第5図のブロック構成図により以下説明する。

中央制御部Hに連結された制御部Gは、データ通信機能を有する制御用計算機を有し、該制御用計算機は制御用通信路を介してその制御下に次の各装置を連結している。

- (1) 画像信号切替装置であるビデオスイッチャー
- (2) 画像メモリ
- (3) 制御装置を介して外部信号により任意の画像を選択再生可能なビデオディスク装置
- (4) 制御装置を介してビデオテープレコーダ
- (5) 駅内或いは車内に設置される各ビデオディスプレイ装置
- (6) 画像作成や編集の機能をはたすべく

(7) 指作車

、大変な労力を要する欠点があった。

近年、視覚的に情報を表示するものの中で動的映像を提供するためのものもあるが、単にテレビブラウン管等のディスプレイ装置を設置したものが多く、その提供情報内容も限定的なものであった。

今後市中における駅の果たす役割は、単に移動のための輸送拠点としてだけでなく、地域文化の中心的な拠点としての役割が高まってきている。

したがって、本発明は1駅のみに限定的に静的情報を表示するのではなく、駅の果たす役割が変貌する中でそれに相応しい情報提供システムの確立を目指すものである。

実施例

以下、本発明の詳細を図につき説明する。

本発明のトータルシステムは、第4図に示したように、端末機器である情報伝達表示部Jと、該情報伝達表示部J・・・を統括する制御部Gと、各制御部G・・・を統括する中央制御部Hとにより構成されている。

勿論制御部Gは、中央制御部Hよりの送信指令

(8) 固定ディスク

(9) フロッピーディスク

(10) プリンター

等の周辺装置

(11) 通信制御装置を介してデータ伝送路

また、ビデオスイッチャーが有する各チャンネルには、

(12) 制御用通信路を介して制御用計算機に連結している画像メモリをビデオ信号変換装置を介して

(13) 制御装置と制御用通信路を介して制御用計算機に連結するビデオディスク

(14) 制御装置と制御用通信路を介して制御用計算機に連結するビデオテープレコーダ

(15) 画像伝送路

(16) 駅内或いは車内に設置される各ビデオディスプレイ装置Jに連結し、データ伝送路と画像伝送路とにより中央制御部Hに連結している。

このように、各ビデオディスプレイ装置J・・・は、制御用計算機の出力するチャンネル選択信

号を、制御用計算機に接続された制御用通信路より受けとり、チャンネル切り換え機能を行うビデオスイッチャーである画像信号切換装置に接続されており、各々独立の表示部として機能するようになっている。

また、ビデオスイッチャーはチャンネル1～nを有しており、例えばチャンネル5～nにn-4台の各ビデオディスプレイ装置を接続する。

この場合、チャンネル1はビデオ信号変換装置を介して制御用計算機が読み書きできる画像メモリと接続され、さらに画像メモリは制御用通信路に連結され、制御用計算機の制御下に置かれている。

チャンネル2はビデオディスクと接続され、さらにビデオディスクは制御装置を介して制御用通信路に連結され、制御用計算機の制御下に置かれている。

チャンネル3はビデオテープレコードと接続され、さらにビデオテープレコードは制御装置を介して制御用通信路に連結されて、制御用計算機の

ディスプレイ装置・・・へ各々独立的に映像を送ることができる。

例えば、予め記憶されているビデオディスク中の映像を、制御用計算機内にプログラムされたスケジュールによって自動的に順次再生することが可能であるし、該計算機とその周辺装置を用いて画像作成や編集を行えるので、画像メモリ等の一次記憶装置とビデオ信号変換装置を介して、これらの情報を出力するように設定することもできる。

さらに、データ伝送路を通じて制御用計算機に割り込みをし、画像伝送路を通じて動画や静止画像を送り、これらの情報をビデオディスプレイ装置に表示させたり、或いは、ビデオテープレコードや画像メモリ等に記憶させたり、その逆を行ったりすることが出来る。

これらの各機能はデータ伝送路と連結してあるので、中央制御部Hの制御用計算機と各駅の制御用計算機、又は、制御用計算機と他の駅の制御用計算機間において行えるものである。

制御下に置かれている。

チャンネル4は、直接画像伝送路に連結されている。

さらに制御用計算機は、ターミナル（制御用操作卓）、固定ディスク、フロッピィディスク等の手段により種々の情報を合理的に管理、操作すべくこれらの周辺装置と制御用通信路を介して接続されている。

また、他の制御部Gとの間（駅と駅間）、中央制御部Hとの間（中央制御部Hと駅間）の双方向データ通信路機能を有する通信制御装置を介してデータ伝送路に接続されている。

中央制御部Hの構成は、ビデオスイッチャーに連結される各ビデオディスプレイ装置・・・はなく、他の構成は前記制御部Gと同様である。

したがって、作動状態はビデオスイッチャーに制御用計算機から選択信号を与えることによって、ビデオスイッチャーに接続されている各装置（画像メモリ、ビデオディスク装置、ビデオテープレコード）及び画像伝送路より、各ビデオディス

クプレイ装置Jの設置については、図1に第1図に示したように、駅内に設置されている乗車券自動販売機に組合せ構成する場合である。

1は乗車券自動販売機であり、販売機1の正面部には乗車券自動販売機能を果たす操作部Aとして、100円玉等の硬貨の投入口2、千円札等の紙幣投入口3、カードの投入口4、料金別押しボタン5・・・、乗車券及び釣り銭の取り出し口6が設けられている。

そして、これら操作部Aは機器本体表面の下面部1bに形成されている。

一方機器本体表面の上面部1aは、段部により空間部7が形成されている。

この空間部7は、ビデオディスプレイ装置である情報伝送装置J（図示せず）を挿入して一体的に組合せ取り付けするものである。

但し、この部分の活用についてはこの種情報伝送装置Jにのみ限定されるものでなく、例えばパンフレットの配付のためのスペースとして用いて

もよいし、その値が一定の販売機等種々の機器類との組合せが可能である。

また、この空間部分4の形状や券売機との組合せ位置は図示した上部に限らず種々設計変更が可能である。

そして、販売機1の操作部Aと制御部Cを連動させる場合には、操作部A側には、各機能の動作がコード化された人力情報を読み電界の変化に変換して送出する出力部が設けられ、制御部C側にはこの出力部より出力される情報を読み取るホスト装置が設けられる。

この構成の場合には、各種機器との組合せが可能であるので、それぞれの機器の消耗度、或いは、機種グレードアップに伴ってその機器のみを変えればよい。

第2には、第2図に示したように電車車内の吊るし広告部8に形成する場合である。

天井より吊り下げられた広告部8を、広告部8の同種の固定枠の枠内に液晶画面等によるパネル形式により情報伝達表示部Jを形成する。

制御部からの指令により逐次情報伝達表示部に表示することができるから、例えば駅構内で事故などが発生した場合は、誘導や改札止め、事故発生状況の説明や振り替え輸送体制の図解等を克明に知らせることができる。

また、駅周辺における事故においても同様の体制をとることができるし、交通事情をも紹介することができる。

さらに、他の駅や走行中の車両に対しても相互に情報を伝達し得るので、乗客に適切な指示を与えると共に乗客側も混乱することなく各自にあった判断を下すことができる。

これらの場合において、各情報伝達表示部の全面を通して同一放映をし得ることは勿論であるが、その必要がない場合には、特定のブロック内の駅にのみ情報表示を行わしめることができる。

よって、乗客或いは通行人に対して各種指示を行う事を可能とし、また、駅近郊の紹介、種々の催事の宣伝広告等多機能の情報提供管理を行うものであり、年々重要性を増すターミナルとしての

商、この情報伝達表示部Jは車内の両側壁面9に形成してもよい。

この構成の場合には、従来のようにポスターを一つ々々張り換える必要がなく、而も、走行中の車両に対しても所望により瞬時に情報内容を変化させることができ、その情報内容も幅広く選択し得るものである。

第3には、ホームに設置されている売店10の裏壁面形成する場合である。

ホームに設置されている売店10の裏壁面は、現在ごみ置き等に使用されている未利用のスペースであり、この壁面にブラウン管やパネル形式の情報伝達表示部Jに構成するものである。

また、この場合には場所的にスペースを有するので操作部Jを設けるとか、タッチパネル形式の情報伝達表示部に構成することにより、対話形式の情報提供システムとしてもよい。

効果

本発明は上記の如く構成よりなるので、所望の動的或いは静的映像を表示部の交換なしに、制

駅をより一層中継地点としてみるものであり、各種装置を組合せ構成することにより、多目的性、経済性、革新性を高めるものである。

4. 図面の簡単な説明

第1図乃至第3図は本発明の情報伝達表示部の1実施例図、第4図は本発明のシステムの統括図、第5図は制御部の構成を示したブロック図である。

A・・・乗車券自動販売機の操作部 J・・・情報伝達表示部 C・・・制御部 H・・・中央制御部

特許出願人 柴崎 林二郎

特許出願人 牛久久 男

代理人 弁理士 大橋 裕 誠

第 1 図

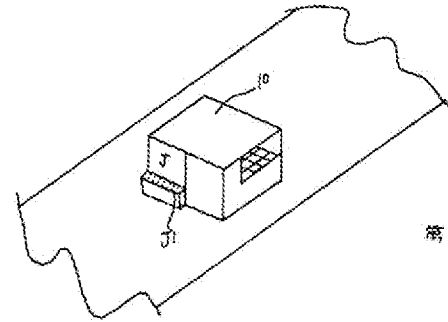
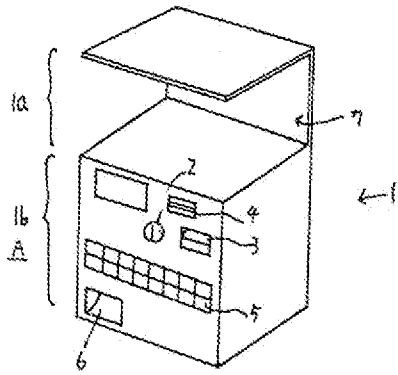

第 3 図

第 2 図

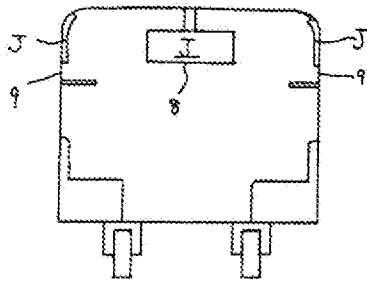

第 4 図

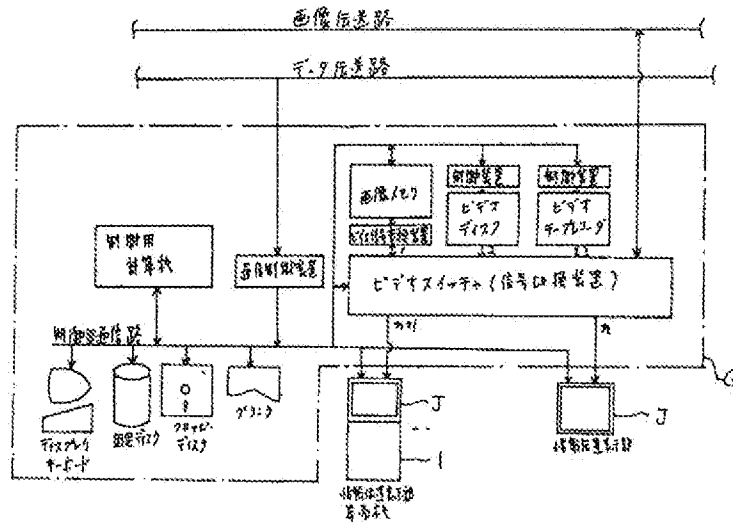
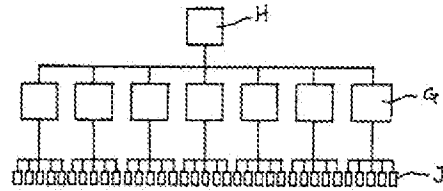

第 5 図

⑩ 日本国特許庁(JP)

⑪ 特許出願公開

⑫ 公開特許公報(A)

昭61-285490

⑬ Int. Cl.⁴

G 09 G 3/00
B 61 K 13/00
G 09 F 9/00

識別記号

庁内整理番号

C-7436-5C
7817-3D
6731-5C

⑭ 公開 昭和61年(1986)12月16日

審査請求 未請求 発明の数 1 (全5頁)

⑮ 発明の名称 車内情報案内システム

⑯ 特 願 昭60-128601

⑰ 出 願 昭60(1985)6月13日

⑱ 発 明 者 品 川 浩 川崎市中原区上小田中1015番地 富士通株式会社内
⑲ 発 明 者 山 本 光 正 川崎市中原区上小田中1015番地 富士通株式会社内
⑳ 出 願 人 富士通株式会社 川崎市中原区上小田中1015番地
㉑ 代 理 人 弁理士 松岡 宏四郎

明 細 書

1. 発明の名称

車内情報案内システム

2. 特許請求の範囲

(1) 列車内に設備され列車内の情報放送を行うための画像情報データの構築を行う情報処理装置(A)と、

作成した画像情報データを画像情報として各表示装置に分配する送出装置(B)と、

各車輻に設けられた表示装置(C)を有し、運行中の列車内で次停車駅及び/又は以遠の案内情報を表示放送することを特徴とする車内情報案内システム。

(2) 前記作成される画像情報データが、少なくとも次停車駅名と、到着予定時刻と、次停車駅で継続する自社系又は他社系の交通機関の路線別運行ダイヤの中の到着予定時刻に所定の乗り換え時間を加えた時刻後に発車する最初の列車やバス等に関する特急、急行各停、発車時刻、行先、乗車ホーム、等の案内情報を含んで構成されることを特徴

とする特許請求の範囲第(1)項記載の車内情報案内システム。

(3) 前記表示装置が列車通路脇の壁の上部や、乗客座席の窓上部などに設けられて成ることを特徴とする特許請求の範囲第(1)項又は第2項記載の車内情報案内システム。

3. 発明の詳細な説明

(概要)

列車内の情報案内は従来車掌巡回によるか社内放送設備により音声で行われていた。しかし音声は保存されないで眠っていたりして聴き逃した乗客や忘れた乗客に対して何回もくり返さねば情報の補充が出来ない。それで音声放送の欠点をカバーするため画像による放送を行う。又は併用しようとするもの。

(産業上の利用分野)

本発明は運用中の列車に乗っている乗客を対象とした画像放送による情報案内サービスシステム

に際し特に表示装置によって一定の時間内はいつでも見られる消えない情報サービスを提供するシステムに関する。

(従来技術の問題点)

従来のこうした情報アナウンスは車掌室に備えられた放送設備から有線で各車鈴に備えられたスピーカを介して乗客音声放送されていた。しかし音声は一過性で消えてしまうので、情報が必要な乗客が何らかの理由で聴きもらしたり忘れたりすると情報が必要な乗客がこれを補充出来ないと云う欠点があり、この欠点をカバーしようとして繰り返し放送すると他の乗客にとってはうるさいと云う問題があった。

(解決の手段)

本発明の意図する所は上記にかんがみ案内する情報内容を画像情報として各車輛に放送(表示)することにより情報を必要とする乗客が必要であればいつでも読取ることが出来る様に一定の時間

は保存された形態で乗客に提供することである。

上記意図を実現するためのハード側の構成は列車内の車掌室等の乗務員が管理する場所に、乗務員が管理し、操作して画像情報データの選出と編集を行う情報処理装置と、該装置で作成(選出と編集)した画像情報データを画像情報として各表示装置に分配放送する送出装置とを備え、各車輛側に夫々備えた表示装置を介して、次の停車駅でおりる乗客が必要とする案内情報を表示放送することにより解決しようとするものである。

なを少し補足するなら上記表示内容として作成される画像情報データは次停車駅で停車する以前に表示される様運用することと、次停車駅でおりる客が必要とする駅名、到着予定時刻(おくれる場合は修正されたものが望ましい)ホーム等と乗り換えのための接続に関する情報を接続可能なダイヤグラムから選んで見やすい場所に設置した表示装置に継続表示して、次々と停車前までには更新して提供することか運用上の要件となる。

(実施例)

第1図は本発明の原理図を兼ねる一実施例の説明図であり、

第2図と第3図と第4図は第1図の補足図を示し、第2図は情報処理装置内で行われる画像表示データを作成する作業を作業フロとして説明するもの、

第3図は入力編集を機能ブロック図で説明するもの、

第4図は表示装置の設置場所を説明するものである。

第1図中の鎖線で区切ったAの部分の中が情報処理装置、Bの部分の中が送出装置、Cの部分の中が各車輛側の表示装置を示し、情報処理装置Aは中央処理装置1(CPUと通称す)に接続するモニタ部を含む操作部2と、CPU1とともにデータ編集を行い、データ編集の作業場となる主記憶3(MSと通称す)と、少なくとも現在運行中の現列車の始発駅から終着駅までの間の各駅を発着する計画時刻と停車駅名と各駅と発着ホーム番号

を含む自列車の運行計画データと、上記自列車が停車する駅から発着する乗り継ぎ列車(当該路線の普通列車や急行列車や特急列車など当該路線外の別路線を運行され別方向に向う普通列車や急行列車、特急列車などさらには以遠に接続する列車や連絡船、さらには停車駅をターミナルとするバス等の交通機関の車も含んで良い総称として乗り継ぎ列車と称する)の夫々の駅から発着する時刻、行先、発着ホーム(ターミナル)情報を含む各停車駅で関連する乗り継ぎ列車の運行計画(列車ダイヤ)情報データと、上記現列車の各停車駅についてホーム間やホームターミナル間の乗り継ぎ移動に要すると思われる必要余裕時間情報を含む編集に必要な各情報を少なくとも含むソースデータを記憶しているデータファイル4、5をデータベース6で結んで形成されており、

操作部2から操作して発車後、停車前の時期に第3図で二重丸くで示す設定データの一つ、すなわち、次停車駅名(コード化されていて良い)を設定するとデータファイル4、5の中から設定停

率駅に係る駅名を表示するためのデータや、到着予定時刻を示すためのデータや、乗り継ぎ列車の発着時刻や発着ホームに関するデータや必要があれば乗り継ぎのための必要余裕時間に関するデータが次停車駅名設定部31に駅名を設定することを「キー」としファイル4、5からMS3内の各設定部に呼び出されて設定され、操作員は現在の列車運行ダイヤと予定との間の差(運行のおくれ等による)があれば各設定部の到着時刻や必要余裕時間や表示項目を修正設定してから編集を行なう。

編集はまず、現運行列車の次停車駅到着時刻設定部32に設定された時刻に余裕時間設定部35に設定された各方面への乗り継ぎのための必要余裕時間を加えた時刻と、列車ダイヤ記憶部34に必要な分だけファイル5より取り込んで記憶された各方面へ発車する乗り継ぎ列車の発車時刻データ群との間の大小判定を一つの方面毎に比較部36で行い一つの方面について乗り継ぎ接続可能な列車を選び列車の選択部37に渡す。次いで列車選択部37は発車時刻の大小判定を行い、比較部

36で選んだ接続可能な列車の中で列車クラス毎に最も早い時刻の列車を選んでフォーマット編集部38の所定フォーマット位置に格納する作業を、必要な方面分だけ繰り返すことにより接続情報データの編集を行う。

そして次停車駅に関する停車駅名、到着時刻、着ホームと併せて、各方面に乗り継ぎ可能に接続するもよりの列車の発車時刻、ホーム、行き先、方面を示すデータと、列車名、急行普通の別、列車かバスか等の車種、等の従属するデータのファイル4より取り込んだものを併せてフォーマット編集したものを得て編集が完成する。

なお、これらの作業は必要あれば操作部2でモニタしつつ設定し、修正して、主にCPU1とMS3の間で実行される。

しかし、編集を終った画像情報データは該データを各列車の表示装置に表示する画像情報に変換し送出する送出装置Bに渡され、画像情報に変換されて画像として各表示装置21~2nから放送される。

そして各表示装置21~2nは第4図に示す様に各列車の通路に隣接する壁あるいは乗客座席の窓上部の平均的成人が歩く時目の高さ程度に配置することが好ましい。

なを本発明の変形として列車が遅れる場合があるので、到着予定時刻の変更は列車内で変更可能にしておけば、あらかじめ編集したデータをディスクカートリッジあるいはフロッピーディスク等の媒体で供給して、列車内での乗務員の作業大幅に軽減する事も、またもっと大がかりになるが、該編集を列車運行を管制する中央指令室で行って各列車にオンライン供給することも可能であり、乗客が受け取るサービスとしてはほぼ同じ効果を有するが乗務員が直接作業に係る時間が少くなると云うメリットを持つ。

(効果)

以上説明した様に本発明によれば列車内の情報案内を消えない形で必要な乗客が必要とする時点で情報密度の高い案内情報を提供することが出来

るので音声放送のみによる運用に較べて必要のない乗客にうるさがられずサービスの質が向上するのみならず運行中の列車の運行に合せて必要時には修正することが出来、運用側から見ても、よりきめこまかいサービスを行うことが出来ると云う効果を有するものである。

4. 図面の簡単な説明

第1図は本発明の原理説明図を兼ねる一実施例の説明図でシステム構成を説明するもの。

第2図、第3図、第4図は第1図の補足図で夫々一実施例の作業フローをフローとして説明するものと、機能ブロックとして説明するものと、表示場所を説明するものである。

図中Aは情報処理装置、Bは送出装置、Cは表示装置を示す。また、付番は細部を示し、1はCPU、2は操作部、3は主記憶(MS)、4、5はデータファイル、6はバスを示す。また、11は編集された表示データのセット部、12は画像データへの変換部、13は送信部、14は表示系制御部を示す。

さらに 21, 22, ... 2n は各客車の表示部を示す。

また 31 は次停車駅名設定部、32 は着時刻設定部、33 は表示項目設定部、34 はダイヤの一部を一時記憶するダイヤ記憶部、35 は余裕時間設定部、36 は比較部、37 は選択部、38 はフォーマット編集部を示す。

代理人 弁理士 松岡 宏四

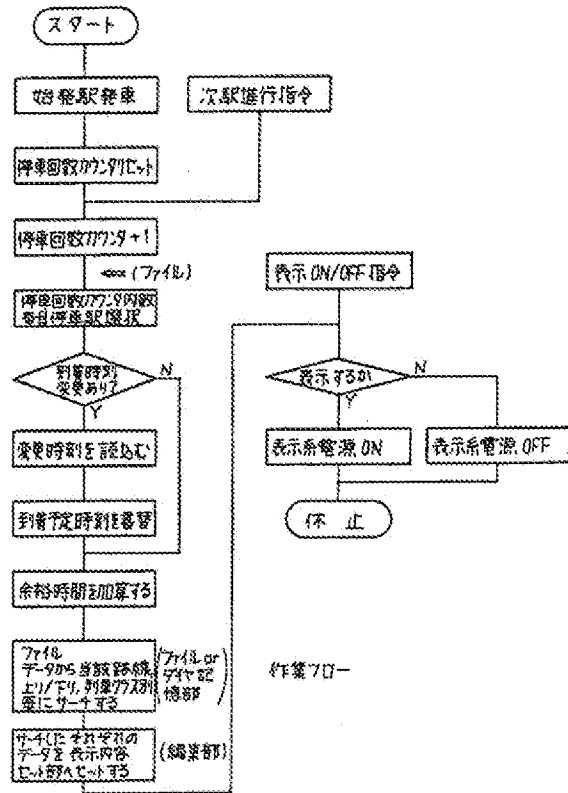

第 2 図

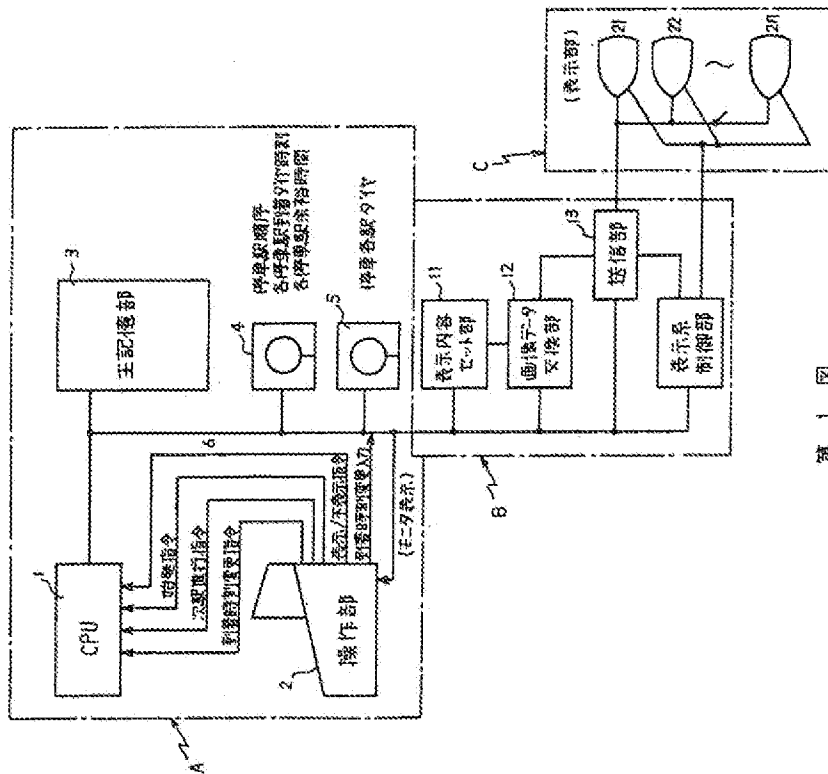

第 1 図

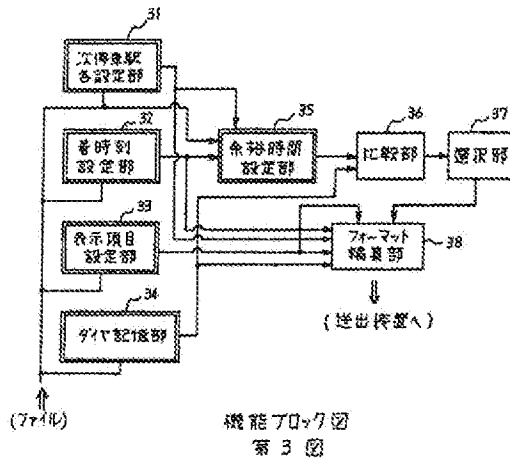

⑤ 日本国特許庁(JP)

⑩ 特許出願公開

② 公開特許公報(A) 平4-160991

⑥ Int. Cl.³

識別記号

庁内整理番号

④ 公開 平成4年(1992)6月4日

H 04 N 7/08
9/00

A 8838-5C
C 7033-5C

審査請求 未請求 請求項の数 1 (全9頁)

⑧ 発明の名称 移動体用文字放送受信システム

⑨ 特 願 平2-288142

⑩ 出 願 平2(1990)10月25日

⑦ 発 明 者 前 川 義 雄 東京都千代田区丸の内1丁目6番5号 東日本旅客鉄道株式会社社内

⑦ 発 明 者 梶 田 亨 東京都千代田区丸の内1丁目6番5号 東日本旅客鉄道株式会社社内

⑦ 発 明 者 田 玉 希 東京都品川区北品川6丁目7番35号 ソニー株式会社社内

⑦ 発 明 者 佐 藤 文 久 東京都品川区北品川6丁目7番35号 ソニー株式会社社内

⑦ 出 願 人 東日本旅客鉄道株式会社 東京都千代田区丸の内1丁目6番5号

⑧ 出 願 人 ソニー株式会社 東京都品川区北品川6丁目7番35号

⑨ 代 理 人 弁理士 松隈 秀盛

最終頁に続く

明 細 書

関する。

発明の名称 移動体用文字放送受信システム

特許請求の範囲

移動体に搭載されたテレビジョン放送受信用チューナと、該チューナで受信したテレビジョン放送信号から文字放送データを抽出して復調する文字放送デコーダと、該文字放送デコーダで得た文字放送データを複数画面分記憶するメモリと、該メモリに記憶された文字放送データを表示させる表示手段とを設け、

上記文字放送デコーダで必要とする文字放送番組の少なくとも1画面分の文字放送データを復調したとき、この復調して得た画面の文字放送データを、上記メモリの対応したエリアに記憶させ、上記メモリの記憶データの更新を行うようにした移動体用文字放送受信システム。

発明の詳細な説明

(産業上の利用分野)

本発明は、電車等の移動体に搭載されるものに適用して好適な移動体用文字放送受信システムに

(発明の概要)

本発明は、電車等の移動体に搭載される移動体用文字放送受信システムにおいて、文字放送デコーダで必要とする文字放送番組の少なくとも1画面分の文字放送データを復調したとき、この復調して得た画面の文字放送データをメモリの対応したエリアに記憶させ、文字放送データを記憶するメモリの記憶データの更新を行うようにし、文字放送番組の全てのデータが受信されないときでも、文字放送番組の良好な表示ができるようにしたものである。

(従来の技術)

近年、電車等の移動体に、テレビジョン受信機を取付け、VTR等から再生した映像を受像させて乗客にサービスすることが行われている。この場合、電車の屋上にアンテナを取付け、このアンテナで地上の送信所からのテレビジョン放送信号

を受信し、受像させるようにしたものもある。

〔発明が解決しようとする課題〕

ところが、このようなテレビジョン放送信号を受信できるのは、比較的電波状態が良い場所を走行するときに限られていた。即ち、都心のようにビル等の障害物が多い地域を走行する移動体の場合には、送信所からの放送信号が不要輻射なく良好に受信できる箇所が少なく、通常のテレビジョン用アンテナを移動体に取付けただけでは受信状態が非常に悪く、実用に耐えない状態の映像になってしまうことが多かった。例えば、東京のほぼ中央部を走行する山の手線の電車の場合、送信所からの距離は非常に近く、本来ならば簡単な構造のアンテナでも良好に受信できる強電界地域であるが、ビル等の障害物が非常に多く、従来の技術でテレビジョン放送をゴーストなく受信するのは不可能に近かった。

また、テレビジョン放送信号の一部を利用して文字放送のための電波が送信されているが、この

の更新を行うようにしたものである。

〔作用〕

このようにしたことで、最初に必要とする文字放送番組の全ての画面のデータをメモリに記憶させておけば、移動体が走行中等にこの文字放送番組の一部の画面のデータだけが受信できたときでも、この受信できた部分のデータだけは最新のデータに更新され、順次文字放送番組のデータが最新のものに更新されていき、メモリには必要とする文字放送番組の全ての画面のデータが記憶されているので、常時該当する文字放送番組の全ての画面の表示が可能になる。

〔実施例〕

以下、本発明の一実施例を、第1図～第4図を参照して説明する。

本例においては、電車に搭載したテレビジョン受像機に文字放送を表示させる受信システムに適用したもので、まずこの受信システムの全体構成

文字放送の信号はデジタルデータ化されて送信されるため、ゴーストの発生を極度に嫌い、移動体での文字放送の受信は不可能であった。

本発明の目的は、電車等の移動体で文字放送の受信が良好にできるようにすることにある。

〔課題を解決するための手段〕

本発明は、例えば第1図に示すように、移動体(1)に搭載されたテレビジョン放送受信用チューナ(43)と、このチューナ(43)で受信したテレビジョン放送信号から文字放送データを抽出して復調する文字放送デコーダ(46)と、この文字放送デコーダ(46)で得た文字放送データを複数画面分記憶するメモリ(47)と、このメモリ(47)に記憶された文字放送データを表示させる表示手段(101)、(102)、(103)・・・(124)とを設け、文字放送デコーダ(46)で必要とする文字放送番組の少なくとも1画面分の文字放送データを復調したとき、この復調して得た画面の文字放送データを、メモリ(47)の対応したエリアに記憶させ、メモリ(47)の記憶データ

を説明する。

第1図及び第2図において、(1)は電車の車体を示し、この車体(1)の側面には片側6箇所の扉(出入口)(11)、(12)、(13)・・・(16)及び(17)、(18)、(19)・・・(22)が設けてあり、車内のそれぞれの扉(11)～(22)の左右の戸袋部の上部に、テレビジョン受像機(101)、(102)、(103)・・・(124)が設置してある。例えば第2図に示すように、扉(19)の左右の戸袋部の上部に、テレビジョン受像機(117)と(118)とが取付けてある。この場合、それぞれのテレビジョン受像機(101)、(102)、(103)・・・(124)は、液晶パネル等を使用した薄型のものとしてある。

そして、この各テレビジョン受像機(101)、(102)、(103)・・・(124)に文字放送を表示させるのであるが、この文字放送を受信するための4個のアンテナ(30a)、(30b)、(30c)、(30d)を、車体(1)の屋上(2)のベンチレータ(3)及び(4)の周囲に取付けてある。この場合、それぞれのアンテナ(30a)、(30b)、(30c)、(30d)は、第3図に示すように、一端部が近接し

た2本の導体棒(31)、(32)と、この導体棒(31)、(32)と所定間隔あけて配置された反射器(33)とよりなるダイポールアンテナで構成され、2本の導体棒(31)、(32)の間のギャップ部を、バルーン(マッチングトランス)を介して同軸ケーブル(35)(第3図参照)に接続し、この同軸ケーブル(35)を後述する床下ユニット(40)内の切換器(41)に接続する。2本の導体棒(31)、(32)の長さは受信チャンネルの周波数に応じて選定してあり、反射器(33)はこの2本の導体棒(31)、(32)を合わせた長さよりも長くしてある。

そして、4個のアンテナ(30a)、(30b)、(30c)、(30d)は、水平方向に90°ずつ取付け角をずらしてあり、アンテナ(30a)、(30b)はベンチレータ(3)の前後(レールと平行する方向)に取付けてあり、アンテナ(30c)、(30d)はベンチレータ(3)の隣のベンチレータ(4)の左右(レールと直交する方向)に取付けてある。

ここで、ベンチレータへのアンテナの取付け状態を詳しく説明すると、この車体(1)の屋根(2)には

ないようにしてある。そして、このカバー(24)の上部に、アンテナ(30c)及び(30d)を構成する連結部材(34)の一端部を固定し、このそれぞれの連結部材(34)のほぼ中央部に反射器(33)を固定すると共に、他端部に導体棒(31)、(32)を固定する。ここで、2本の導体棒(31)と(32)とは、所定のギャップを設けて連結部材(34)に固定する。また、連結部材(34)は絶縁材とする。また本例においては、導体棒(31)、(32)と反射器(33)とを、断面がL字型のアンギュル材とし、取付けが容易にできるようにしてある。

ここで、各ベンチレータの上部と反射器(33)の下端との間の高さ方向の間隔Hを、少なくとも15mmとし、各ベンチレータと反射器(33)との水平方向の幅を、少なくとも幅20mmとし、さらに反射器(33)の高さBを、70mm以上とする。この場合、ベンチレータとの高さH、幅及び反射器(33)自身の高さBの値は、大きい方がアンテナの特性上好ましいが、実際には屋上(2)に搭載できる機器の大きさが車両限界等の規格で決められており、あ

複数のベンチレータ(3)、(4)、(5)・・・が取付けてあり、このベンチレータ(3)、(4)、(5)・・・は走行時に外部の空気を車内に押し込む換気装置として機能するいわゆる押し込み型のベンチレータと称されるもので、各ベンチレータ(3)、(4)、(5)・・・は四隅の脚部(3a)、(4a)、(5a)・・・がボルト(23)により屋上(2)に固定してある。この場合、各ベンチレータ(3)、(4)、(5)・・・は、車体(1)と絶縁した状態で取付けてある。

そして、ベンチレータ(3)の四隅の脚部(3a)を固定しているボルト(23)を利用して、2個のアンテナ(30a)、(30b)を取付ける。また、ベンチレータ(3)の隣のベンチレータ(4)の四隅の脚部(4a)を固定しているボルト(23)を利用して、2個のアンテナ(30c)、(30d)を取付ける。

第3図及び第4図にこのアンテナ(30c)、(30d)のベンチレータ(4)への取付け状態を拡大して示すと、ベンチレータ(4)のまわりには、コの字型のカバー(24)がボルト(23)で取付けてある。この場合、カバー(24)がベンチレータ(4)の通気部(4b)を塞が

まり大きなアンテナを取付けることは出来ず、上述した値或いはこの値より若干大きな値に制限される。

このようにして4個のアンテナ(30a)、(30b)、(30c)、(30d)を取付けてあることで、それぞれのアンテナ(30a)、(30b)、(30c)、(30d)は導体棒(31)、(32)が設置された方向の電波だけを受信し、反対側(ベンチレータ側)から導体棒(31)、(32)に向かう電波は、反射器(33)により遮蔽され、反射電波による定在波の発生を抑えることができる。従って、90°ずつ設置位置が異なる4個のアンテナ(30a)、(30b)、(30c)、(30d)で、ほぼ360°全ての方向から来る電波を受信することができる。

そして、このように構成される4個のアンテナ(30a)、(30b)、(30c)、(30d)を、車体(1)の床下に吊り下げられた床下ユニット(40)内の切換器(41)に同軸ケーブル(35)で接続する。この床下ユニット(40)内には、文字放送受信のための機器が収納され、切換器(41)は後述する判別回路(44)の制御で、何れかのアンテナから供給される受信信号を選択

的に出力する。そして、この切換器(41)が出力する受信信号を、ブースタ(42)を介して、ゴーストリダクションチューナ(43)に供給し、このゴーストリダクションチューナ(43)で予めセットされた所定のチャンネルのテレビジョン放送信号を受信する。この場合、ゴーストリダクションチューナ(43)は、垂直帰線期間内に挿入されたGCR信号等を用いて、受信放送信号のゴーストリダクションを行うもので、選局部、中間周波増幅/復調部と共に、ゴースト除去フィルタ、GCR信号抽出回路、比較回路、制御回路等を備えており、電波の乱反射等により歪みが生じたGCR信号と基準信号とを比較して、反射波信号を抑圧するようになされている。

ここで本例においては、このゴーストリダクションチューナ(43)で得た所定チャンネルのテレビジョン放送信号を判別回路(44)に供給し、この判別回路(44)で受信したテレビジョン放送信号に含まれる同期信号のレベルを判別し、切換器(41)でのアンテナ線の選択を、最も良好なレベルの同期

(47)に記憶させる。

ここで、このメモリ(47)の構成について説明すると、このメモリ(47)はデータ記憶部が複数のエリアに分割され、第5図に示すように各エリアが使用される。即ち、4つの文字放送番組A、B、C、Dを記憶できるようにしてあり、それぞれの番組毎に1ページから10ページまで10画面分記憶できるエリアa1~a10, b1~b10, c1~c10, d1~d10を有する。この場合、各エリアa1~a10, b1~b10, c1~c10, d1~d10は、搭載された車両(1)の運転開始時に一旦所定の文字放送番組のデータが記憶されると、各エリア毎に単独で記憶データの更新ができるようにしてあり、1つの文字放送番組の一部のページ(画面)のデータだけが受信できたときには、この受信できたページの記憶エリアのデータだけを置換えさせる。従って、各文字放送番組A、B、C、Dを構成する各ページの記憶データは、同時に受信したものではない場合がある。なお、それぞれの文字放送番組A、B、C、Dとして、10ページ以下のページ数で構成される場合に

信号が得られるものにして、いわゆるダイバースティアンテナを構成する。この場合、この判別回路(44)にはタイマ回路(45)が接続してあり、タイマ回路(45)による制御で、上述したレベル判別を所定間隔で行うようにしてある。

そして、ゴーストリダクションチューナ(43)で得たテレビジョン放送信号を、文字放送デコーダ(46)に供給し、この文字放送デコーダ(46)で放送信号の垂直帰線消去期間に多重された文字、図形等の文字放送信号を得る。この場合、1チャンネルのテレビジョン放送信号で複数の文字放送番組が送出されており、予めセットされた所定の文字放送番組の少なくとも1画面分のデータを得たとき、文字放送デコーダ(46)に接続されたメモリ(47)にこのデータを記憶させる。即ち、文字放送デコーダ(46)は、受信して得たそれぞれの文字放送画面が、完全なものであるか否かを判断する回路を有し、この回路で1画面でも完全な画面のデータが得られたと判断したときには、このデータが必要とする文字放送番組であるとき、メモリ

は、データが得られないページを空きエリアとしておく。

そして、このようにしてメモリ(47)に記憶された所定の文字放送番組のデータを文字放送デコーダ(46)に順次読み出して、データで示される文字、図形等を画像表示させる映像信号とし、この映像信号を同軸ケーブルにより床下ユニット(40)から出力させる。この場合、記憶された4つの文字放送番組A、B、C、Dの内、何れかの番組のデータが少なくとも1画面分置換えられたとき、この置換えられた番組を第1ページから最後のページまで順次読み出して表示させるようにする。

なお、床下ユニット(40)からの出力映像信号は、ベースバンドの映像信号(即ちRF変調されていない映像信号)とする。また本例においては、床下ユニット(40)内に電源回路(48)を備え、この電源回路(48)から直流低圧の電源を出力させる。

そして、この床下ユニット(40)から映像信号を出力させる同軸ケーブルを、車体(1)に取付けられた3分配器(61)に接続し、出力映像信号を供給す

る。また、電源回路(48)から出力される電源も、3分配器(61)に供給する。この3分配器(61)は、供給されるベースバンドの映像信号を3分配するようにしたものである。

そして、この3分配器(61)からの第1、第2、第3の分配出力の内、第1の分配出力を第1の2分配器(71)に供給し、第2の分配出力を車体(1)の第1エンド(一端)側の連結面に設けられた接続端子(62)に供給し、第3の分配出力を車体(1)の第2エンド(他端)側の連結面に設けられた接続端子(63)に供給する。また、3分配器(61)に供給される電源も、第1の2分配器(71)に供給する。

この第1の2分配器(71)は、供給されるベースバンドの映像信号を2分配するようにしたものである。

そして、第1の2分配器(71)で分配された第1の分配出力を後段に接続された第2の2分配器(72)に供給し、第2の分配出力を後段に接続された第13の2分配器(83)に供給する。この場合、3分配器(61)側から供給される電源を、第2及び第

方を車内に取付けられたテレビジョン受像機(113)に供給し、第2の分配出力を後段に接続された第14の2分配器(84)に供給する。

以下、同様にして後段に接続された2分配器(84)、(85)、(86)……(93)で、供給されるベースバンドの映像信号を2分配し、第1の分配出力を車内に取付けられた対応するテレビジョン受像機(114)、(115)、(116)……(124)に供給し、第2の分配出力を後段に接続された2分配器(85)、(86)、(87)……(93)に供給する。但し、最後に接続された第23の2分配器(93)の第2の分配出力は、テレビジョン受像機(124)に供給する。

この場合にも、各2分配器から接続されたテレビジョン受像機及び後段の2分配器に、前段の2分配器側から供給される電源を供給する。

なお、連結面に設けられた接続端子(62)及び(63)は、チューナ等を備えていない他の車両を前後に連結した場合に、この連結した車両(図示せず)の映像信号入力端子と接続するもので、前後の車両へも受信した文字放送等の映像信号を供給

13の2分配器(72)及び(83)に供給する。

この第2の2分配器(72)は、第1の2分配器(71)と同様に2分配を行うようにしたもので、第1の分配出力を車内に取付けられたテレビジョン受像機(102)に供給し、第2の分配出力を後段に接続された第3の2分配器(73)に供給する。

以下、同様にして後段に接続された2分配器(73)、(74)、(75)……(82)で、供給されるベースバンドの映像信号を2分配し、第1の分配出力を車内に取付けられた対応するテレビジョン受像機(103)、(104)、(105)……(111)に供給し、第2の分配出力を後段に接続された2分配器(74)、(75)、(76)……(82)に供給する。但し、最後に接続された第12の2分配器(82)の第2の分配出力は、テレビジョン受像機(112)に供給する。

この場合にも、各2分配器から接続されたテレビジョン受像機及び後段の2分配器に、前段の2分配器側から供給される電源を供給する。

また、第1の2分配器(71)の第2の分配出力側と接続された第13の2分配器(83)の第1の分配出

力できるようにしてある。この場合、前後の車両のテレビジョン受像機が必要とする電源は、それぞれの車両内の電源回路から供給する。

次に、このようにして接続されるテレビジョン受像機(101)、(102)、(103)……(124)に文字放送の画像を表示させる場合の動作について説明する。

まず、文字放送を受信して文字放送デコーダ(46)に接続されたメモリ(47)に、必要とする文字放送番組のデータを記憶させる作業を行う。この場合、テレビジョン放送信号の受信状態が良好であれば、僅かな時間でメモリ(47)への記憶作業が終了するが、実際には車両(1)が走行しているときにサービスを行うものであるので、一時的に受信状態が良好になって、文字放送デコーダ(46)で必要とする文字放送番組の少なくとも1画面分のデータが得られたとき、この得られた画面のデータをメモリ(47)に記憶させ、以前に記憶された同じページのデータを新しく受信したものに更新させる。

即ち、第6図のフローチャートに示すように、

文字放送デコーダ(46)で受信した文字放送番組の画面の組立てを行い、組立てられた画面が完全な画面になるか(即ち組立てられた画面に欠落部がないか)判断する。そして、組立てられた画面が完全であるときには、この画面のデータをメモリ(47)の対応するエリアに蓄込ませ、このエリアのデータを蓄換えさせる。そして、この蓄換えがあったときには、蓄換えられた文字放送番組を、1ページから順に表示させるように、メモリ(47)の記憶データを読出して文字放送デコーダ(46)で出力映像信号を作成させる。また、組立てられた画面が不完全な画面であると判断したときには、組立てた画面のデータを捨てて、このときの受信データは記憶させない。

この文字放送番組の受信を行うときには、車両(1)から見た送信所の方向は走行により変化するが、90°ずつ方向が異なる4個のアンテナ(30a)、(30b)、(30c)、(30d)の何れで良好な受信が可能か判断するダイバーシティアンテナが構成してあり、このそれぞれのアンテナ(30a)、(30b)、(30c)、(30d)を

番組のデータを読み出して文字放送を表示させる映像信号を作成し、この映像信号を各分配器(61)、(71)~(93)を介してテレビジョン受信機(101)~(124)に伝送し、この車内に設置されたテレビジョン受信機(101)~(124)に文字放送番組を表示させる。この場合、メモリ(47)に記憶された4種類の文字放送番組を、数分から数十分のサイクルで順次表示させる。但し、上述したように新しく文字放送番組のデータが受信できたときには、この受信できた番組を第1ページから表示させる。

なお、上述実施例においては、文字放送受信設備だけを設置したが、VTR等の映像再生機器を設け、文字放送番組と交互に再生映像を表示させるようにしても良い。また、新しく文字放送番組のデータが受信できたときに、この文字放送番組を表示させるようにしたが、データの受信状態とは無関係に所定時間毎に4種類の文字放送番組を順次表示させるだけでも良い。

また、上述実施例においては、電車に受信システムを設置したものとしたが、他の移動体(自動

切機(41)で順番にチューナ(43)側に接続して、ブーストリダクションチューナ(43)での受信状態を判断回路(44)で順次判断し、最も良好な放送信号が得られるアンテナに接続させる。

なお、一時的に受信状態が良好になって、文字放送デコーダ(46)で必要とする文字放送番組の画面が得られるのは、受信状態が非常に良い場合に限られるので、大部分が駅等に停車しているときである。即ち、例えば都心を各駅停車で走行する電車の場合、2~3分走行する毎に、数十秒~1分程度駅に停車し、この停車中に文字放送番組の受信が可能になる可能性が高く、比較的高い頻度で文字放送の受信ができる。この場合、1つの文字放送番組の1画面分が伝送されるのに要する時間は、通常1秒未満であることが多く長くても数秒であるので、上述した構成による文字放送番組受信は十分に可能である。

そして、このようにして文字放送デコーダ(46)に接続されたメモリ(47)に文字放送データの取り込みができると、所定間隔で表示させる文字放送

車、船舶等)にも適用できる。

さらにまた、本発明は上述実施例に限らず、その他種々の構成が取り得ることは勿論である。

〔発明の効果〕

本発明によると、移動体が走行中等にこの文字放送番組の一部の画面のデータだけが受信できたときでも、この受信できた部分のデータだけは最新のデータに更新され、順次文字放送番組のデータが最新のものに更新されていき、移動体での受信状態が走行中等で悪化することがあっても、比較的最新のデータによる文字放送番組の表示が常時可能になる。

図面の簡単な説明

第1図は本発明の一実施例を示す構成図、第2図は一実施例のシステムの車体への取付け状態を示す一部破断斜視図、第3図は一実施例の要部を示す斜視図、第4図は一実施例の要部を示す側面図、第5図は一実施例のメモリの使用状態を示す説明図、第6図は一実施例の説明に供するフロー

チャート図である。

(1)は車体、(3)、(4)……(8)はペンチレータ、(30a)、(30b)、(30c)、(30d)はアンテナ、(40)は床下ユニット、(41)は切換器、(43)はゴーストリグクションチューナ、(46)は文字放送デコーダ、(47)はメモリ、(48)は電源回路、(51)は3分配器、(62)、(63)は接続端子、(71)、(72)……(93)は2分配器、(101)、(102)……(124)はテレビジョン受像機である。

	番組A	番組B	番組C	番組D
1ページ	a1	b1	c1	d1
2ページ	a2	b2	c2	d2
3ページ	a3	b3	c3	d3
⋮	⋮	⋮	⋮	⋮
10ページ	a10	b10	c10	d10

メモリのエリア別
第5図

代理人 松 隈 秀 盛

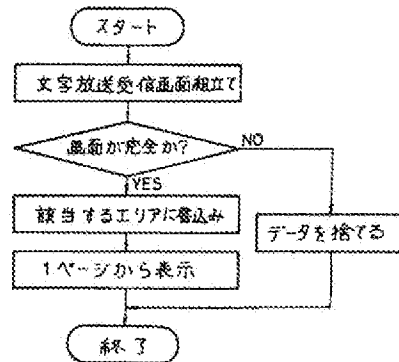

文字放送受信時のフローチャート
第6図

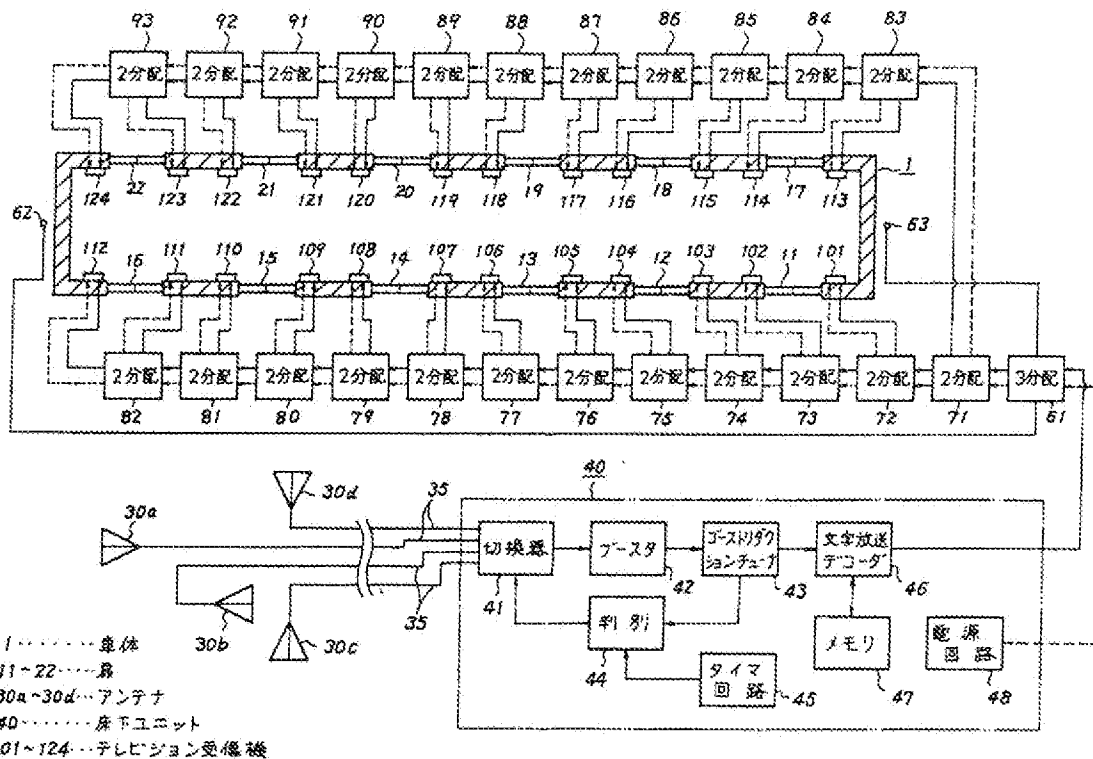

全体構成
第1図

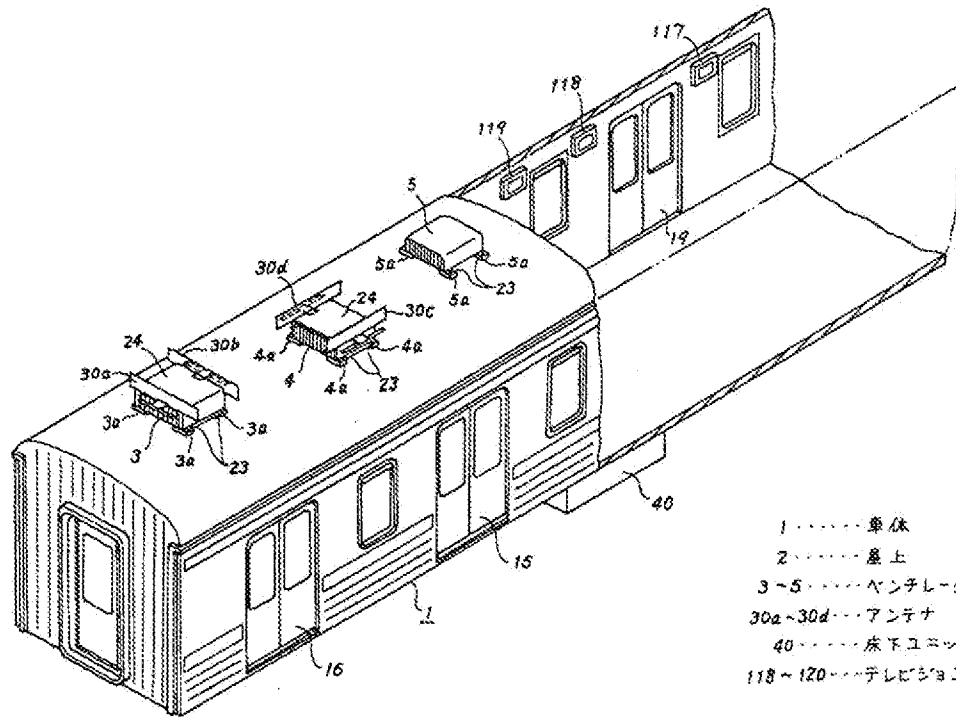

- 1.....車体
- 2.....屋上
- 3~5.....ベンチレータ
- 30a~30d.....アンテナ
- 40.....床下ユニット
- 118~120.....テレビジョン受信機

車体への取付状態
第2図

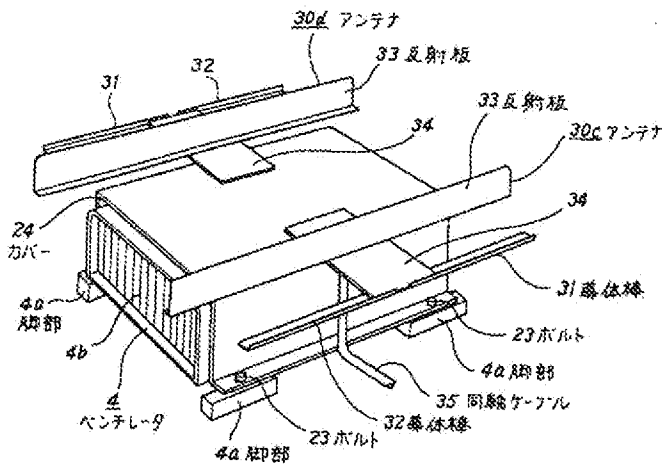

アンテナ付近の拡大図
第3図

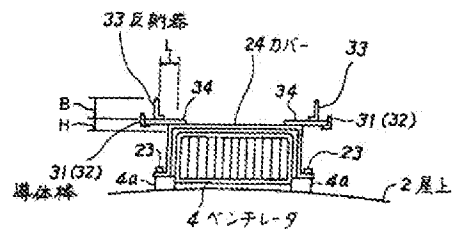

アンテナの取付状態を示す図
第4図

第1頁の続き

⑦発明者	加藤	健一	東京都品川区北品川6丁目7番35号	ソニー株式会社内
⑧発明者	新居	健彦	東京都品川区北品川6丁目7番35号	ソニー株式会社内
⑨発明者	青塚	虎雄	東京都品川区北品川6丁目7番35号	ソニー株式会社内

⑩ 日本国特許庁(J.P.)

⑪ 特許出願公開

⑫ 公開特許公報(A)

平2-223985

⑬ Int. Cl.³

G 09 G 3/00
G 09 F 9/00

識別記号

3 6 3

庁内整理番号

Z

6376-5C
6422-5C

⑭ 公開 平成2年(1990)9月6日

審査請求 未請求 請求項の数 1 (全8頁)

⑮ 発明の名称 輸送機器内の不特定多数の人々に対する不定形情報の提供システム

⑯ 特 題 平1-42966

⑰ 出 題 平1(1989)2月27日

⑱ 発 明 者 天 野 良 和 神奈川県横浜市戸塚区吉田町292番地 株式会社日立製作所横浜工場内

⑲ 発 明 者 梅 澤 功 一 東京都国分寺市東恋ヶ窪1丁目280番地 株式会社日立製作所デザイン研究所内

⑲ 発 明 者 山 口 忠 博 東京都国分寺市東恋ヶ窪1丁目280番地 株式会社日立製作所デザイン研究所内

⑲ 発 明 者 福 田 伸 夫 東京都国分寺市東恋ヶ窪1丁目280番地 株式会社日立製作所デザイン研究所内

⑳ 出 願 人 株式会社日立製作所 東京都千代田区神田駿河台4丁目6番地

㉑ 代 理 人 弁理士 小川 勝男 外1名

最終頁に続く

明 細 書

〔従来の技術〕

1. 発明の名称

輸送機器内の不特定多数の人々に対する不定形情報の提供システム

従来、電車やバスなどの不特定多数の人々が利用する輸送手段では、通常、その機器内に広告や告知などの情報を印刷物として吊り下げたり、壁面に掲示したりしている。これらは普通、期間を定めて掲示しており、広告の場合は、一定期間での掲載契約により輸送手段提供者が収入を得ている。

2. 特許請求の範囲

1. 不特定多数の人々に対し、限られた空間を輸送手段として提供する輸送機器内に、表示内容が随時変化可能な不定形情報を提供する表示装置と、この表示装置に提供情報を輸送機器内から送出する手段と、輸送機器外からの送信情報を受信して輸送機器内の上記送出手段に供給する手段を備えたことを特徴とする輸送機器内の不特定多数の人々に対する不定形情報の提供システム。

尚、この種の関連公知例として1989年2月14日発行の電波新聞に掲載された『液晶ディスプレイ採用車内新映像サービスシステム』がある。

3. 発明の詳細な説明

〔産業上の利用分野〕

本発明は、航空機や電車、バスなどの限られた空間を輸送手段として使用する不特定多数の人々に対し、不定形情報を提供する表示装置を設置することにより、その輸送機器内での時間を有効利用する機会と多様な情報を提供するシステムに関する。

〔発明が解決しようとする問題点〕

上記従来技術は情報提供側から見ると、提供する情報が、印刷物の掲示という点から、前述したように一定期間掲示されており、掲示情報を変化させるには、その機器内に掲示している印刷物をその都度取替える必要がある。又、これらの掲示情報は通常、単位機器内に数箇所から数十箇所程度にわたり数多く掲示されているのが一般的であり、電車のように数十両連結して使用される場合

などは、その数は数百箇所にも及んでいる。従って図面的に提示を変更する場合など、管理が大変であると共に、情報提供場所の使用効率を上げられないという不具合がある。

一方、情報の受信から見ると、提供される情報は一定期間同じであるため、一度新しい情報を見せると次から注意を払わなくなってしまう。新しい情報が提示してあっても、そこに数十分程度居ると提示情報をあらかた見してしまうため提示場所を占める割に情報量が少ないという不具合がある。発光ダイオードなどを使用した情報提供手段が実在するが、停車駅名や、輸送車両の種類など、情報が固定された定形情報提供に限られている。又、車内に映像や文字情報を提供している例があるが、車内に設置した情報提供に限られ、即時性のある情報提供はされていない。

本発明の目的は、前述した不具合点を解決したシステムを提供することにある。

〔問題点を解決するための手段〕

上記問題点は、不特定多数の人々に対し、限ら

れる空間を輸送手段として提供する航空機、電車やバスなどの輸送機器内に、表示内容が随時変化可能な不定形情報を提供する表示装置と、その表示装置に提供情報を輸送機器の内部及び外部から送出する装置を設置することで達成される。

〔作用〕

輸送機器内の乗降客が利用しない場所、例えば航空機ではロッキングピット、駅舎では待客室、バスでは通気口などに設けた輸送機器内に不定形な被提供情報を設定し、送出する機能と輸送機器外部から送信される情報を受信して送出する機能を有した装置から、乗降客の利用する場所に複数設置した表示装置に、その送出装置から送出された被提供情報を表示することで達成できる。

〔実施例〕

本発明の実施例を以下の図により説明する。

第1図は本発明の全体システムを示している。1は輸送機器、2はその輸送機器に設置されたアンテナ、3は主に提供情報を送信するアンテナ、4は地域別情報送信及び輸送機器からの信号を受

信する装置、5は地域別情報の送信制御と輸送機器からの受信信号を管理する地域別情報制御装置、6は地域別情報制御装置と地域別情報送信装置間の情報信号伝送路である。

〔作用〕

輸送機器をバスに例を取り、第1図を説明する。地域別情報送受信装置4は各バスの停留所に設けられており、地域別情報制御装置5から送出されてきた提供情報を蓄積し、アンテナ3により提供情報を輸送機器1に対し送信している。輸送機器1はアンテナ2で提供情報を受信し、車内に設けられた表示情報信号送出装置と情報信号表示装置で乗客に情報を提供する。輸送機器1は地域別情報送信装置4bに蓄積された情報を3b、2aのアンテナを通じて車内に情報を提供しており、輸送機器1bは地域別情報送信装置4aに蓄積された情報を3a、2bのアンテナを通じて車内に情報を提供している。地域別情報制御装置5は、地域別情報送信装置4に対しどの情報を送出するかを制御している。従って、地域別情報送信装置4aから4aまでの情報送出内容をそれぞれ異なるものと

〔実施例〕

したり、同一のものとしたりすることができる。

また、ある複数地域ごとに送出情報を変化させることもできる。

本システムは双方向性があり、輸送機器1が停留所に到着すると、前述の地域別送受信装置からの提供情報受信と共に、輸送機器1が停留所へ到着したことを告知する信号をアンテナ2によりアンテナ3へ送信する。その信号は、地域別情報送受信装置4で受信され伝送路6を通じ地域別情報制御装置5へ伝送され、輸送機器1の運転状態が把握できると共に、次の停留所へその状態を情報として送出し、待機している乗客へ告知できる。

本図では伝送路6は、強弱しやすいように有線を示してあるが、通信距離等による無線伝送路も勿論使用できる。その場合は、地域別情報制御装置5と、地域別情報送受信装置4にパラボラアンテナなどの送受信アンテナを設置することにより実現できる。

第2図は輸送機器内に設置する表示情報信号送出装置と、情報信号表示装置を示している。7は

第2図は輸送機器内に設置する表示情報信号送出装置と、情報信号表示装置を示している。7は

第2図は輸送機器内に設置する表示情報信号送出装置と、情報信号表示装置を示している。7は

表示情報信号送出装置で、主にビデオディスクやビデオテープ等に収納されている動画を再生する映像情報再生機能7b、主に文字や画像情報を磁気ディスクやメモリーカードのような記憶媒体から読み出したり、付属の入力キーによって情報を入力する、文字画像情報入力機能7a、入力された情報を表示可能なように制御する文字画像情報制御機能7d、映像情報再生機能7bで再生された動画情報と文字画像情報制御機能7dからの情報を合成したりそれぞれを選択したりする映像、文字画像情報合成機能7c、發送機器外からの地域別情報を主に受信し蓄える地域別情報受信機能7f、最終的に乗客への提供情報を情報表示装置へ送出する情報送出機能7g、これらの機能を操作する操作制御機能7aから構成されている。2、3はアンテナ、4は主に地域別情報を送信する地域別情報送信機能、8は表示情報表示装置7から送出された提供情報を表示する情報表示装置、9はその際の伝送路である。10は發送機器の走行状態、停止状態に関する走行情報を受す入力信号である。

通常、提供情報は、ビデオディスクやビデオテープ等に収納されている動画や文字画像情報を各々単独、あるいはそれぞれを合成して提供されているが、地域別情報がアンテナ3を介して地域別情報送信機能4から送信されてくると、アンテナ2で受信し、送信データを地域別情報入力機能7fにより蓄積し、文字画像情報制御機能7d、文字画像情報合成機能7c、情報送出機能7gを経て、情報信号表示装置8に表示する。この提供情報は、發送機器にあらかじめ備え付けた動画や文字画像情報だけでは補えない即時性のある情報を提供することができる。例えば、臨時ニュースを流したり、その地域で行われている限定情報を提供することができる。これらの情報は發送機器の移動経路に沿って地域別情報送信機能4を設置しておけば、その間隔単位で情報提供内容を変える事が可能となる。

第3図は發送機器に列車を想定してその様子を示している。区間1ではカルチャー情報11を、区間2ではイベント情報12、区間3では遊園地

情報13を情報信号表示装置8に提供している例である。この例では情報信号表示装置8全面にわたって情報提供しているが、前述した動画や文字画像情報と合成して提供したり、その一部分を使用して提供することも可能である。

第4図から第7図は發送機器内の情報信号表示装置8を車内に設置した例である。

(発明の効果)

本発明によれば、發送機器内の情報提供場所を有効にしようできると共に、従来のような印刷物を掲示する場合に比べ、管理の手間が省けるばかりでなく即時性と新鮮さを出せるため、乗客に対する情報提供力を強める効果がある。

4. 図面の簡単な説明

第1図は本発明の全体システム例を表す図、第2図は發送機器内の設置機器例の説明図、第3図は地域別情報提供例を示す図、第4図、第5図、第6図、第7図は發送機器内に設置した情報信号表示装置例を示した図である。

符号の説明

1…發送機器、2…發送機器に設置したアンテナ、3…地域別情報送信機能に設置したアンテナ、4…地域別情報送信機能、5…地域別情報制御装置、6…伝送路、7…表示情報信号送出装置、8…情報信号表示装置、9…伝送路、10…走行状態情報入力、11、12、13…地域別情報提供例、14…印刷物による情報提供例

代理人弁理士 小川勝男

図面の浄書(内容に変更なし)
第1図

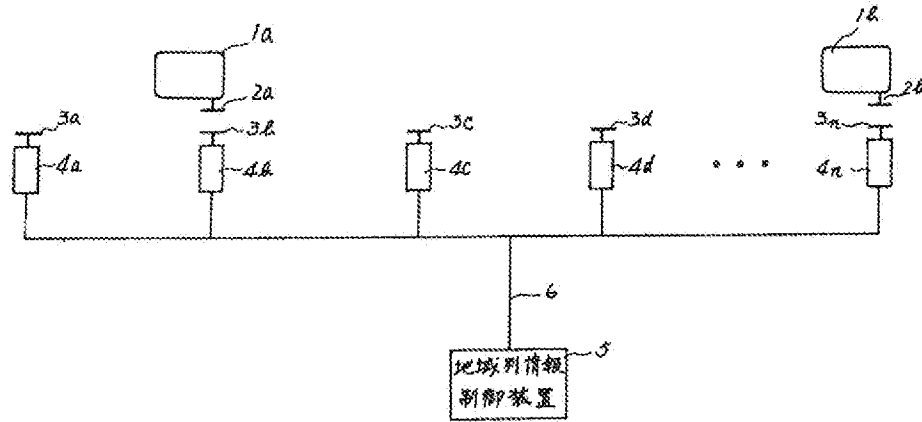

第2図

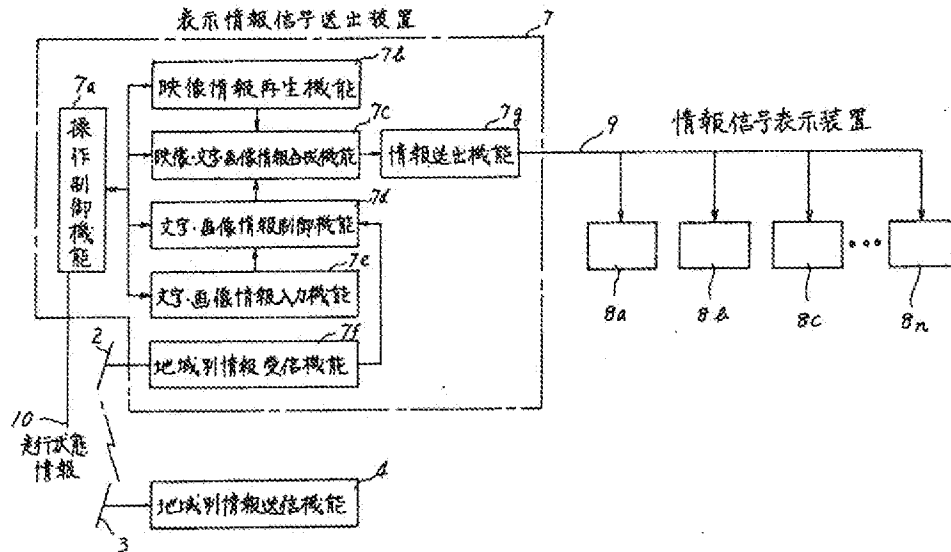

第3図

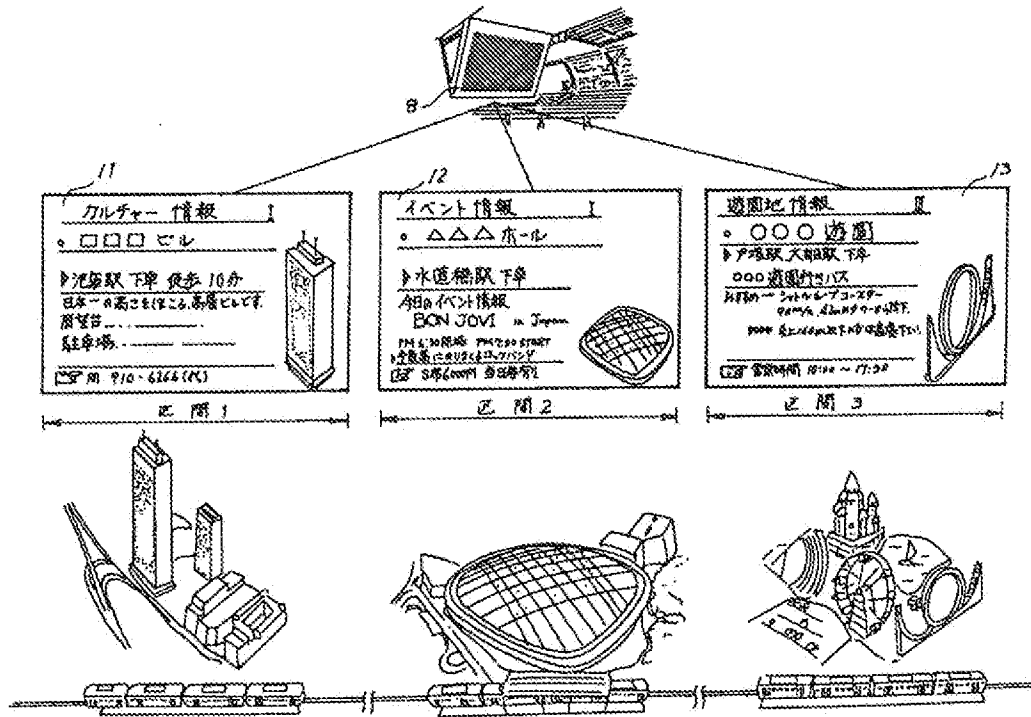

第4図

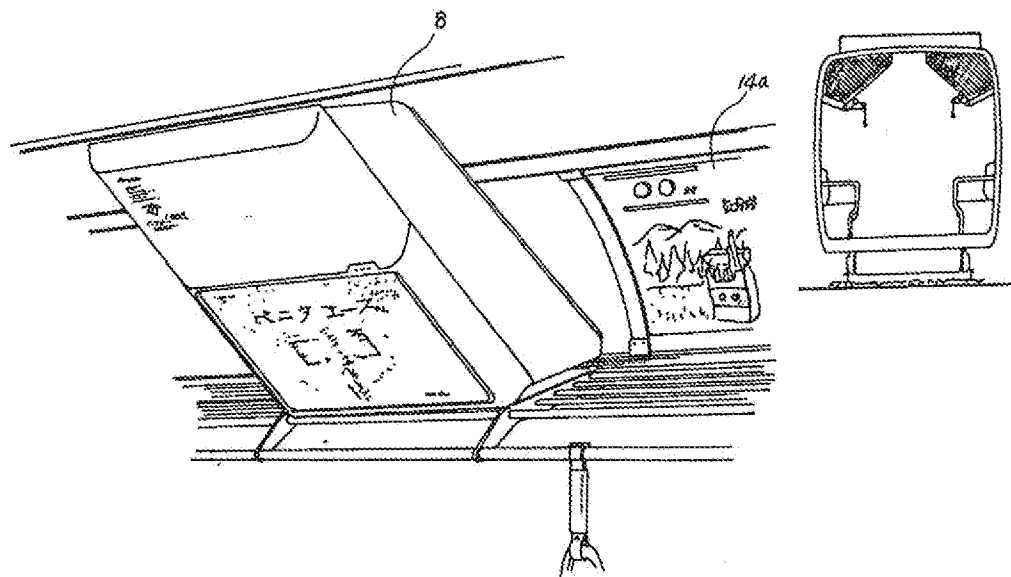

第5図

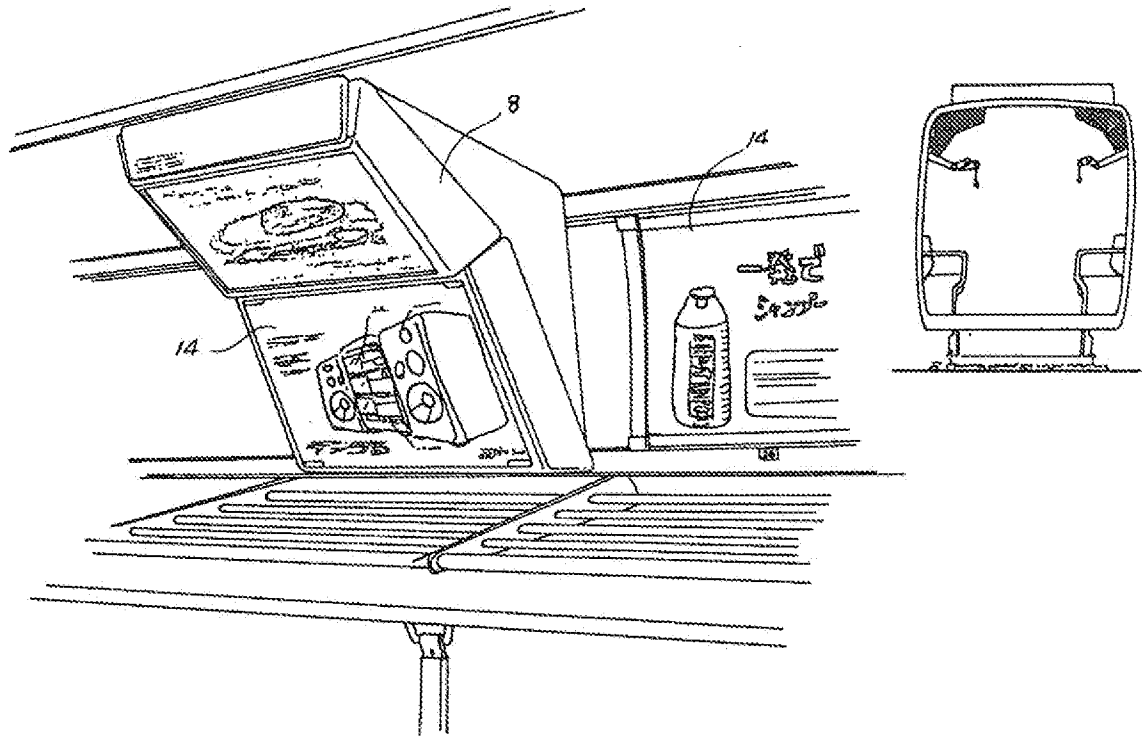

第6図

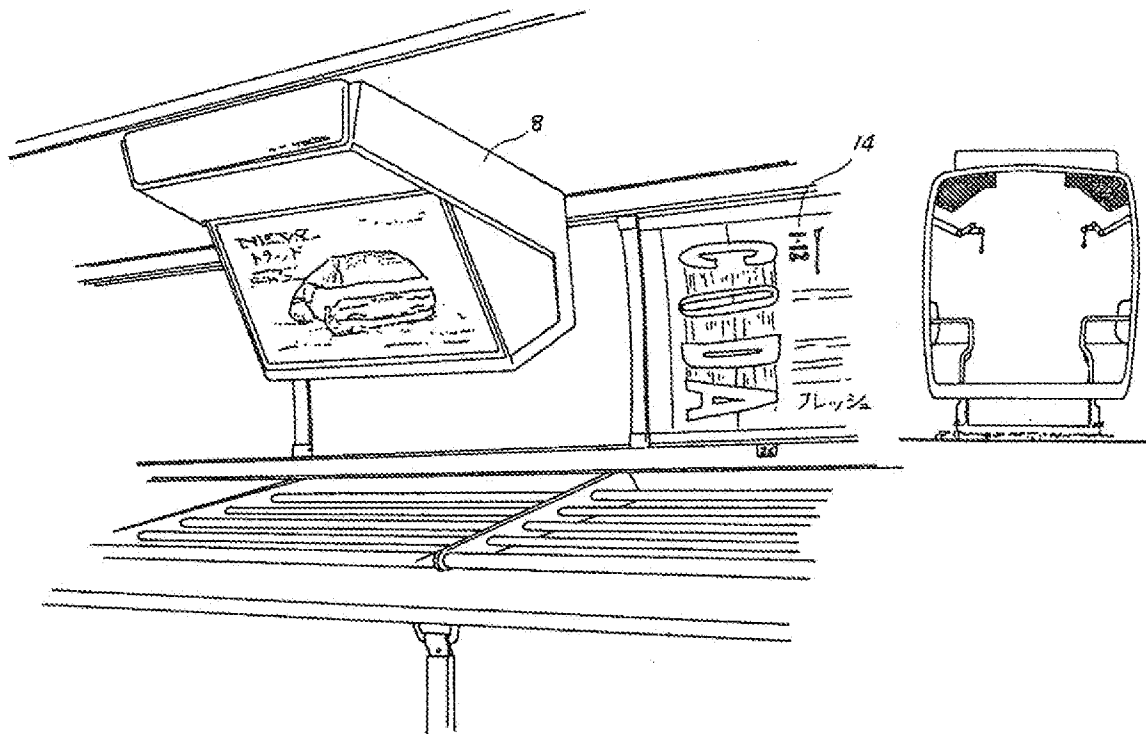

第7図

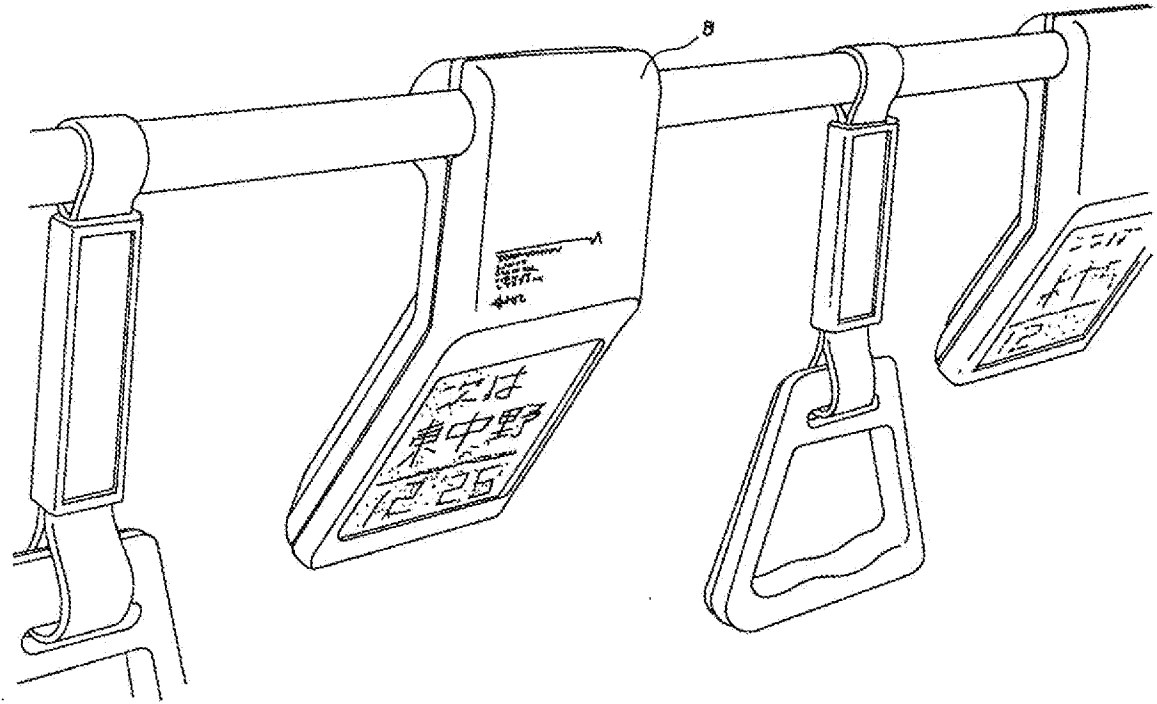

第1頁の続き

◎発明者 川 勝 祥 弘 東京都国分寺市東恋ヶ窪1丁目280番地 株式会社日立製作所デザイン研究所内

手続補正書 (方式)

平成 1 年 5 月 21 日

特許庁長官殿
事件の表示

昭和 56 年 特許第 42966 号

発明の名称
輸送機器内の不特定多数の人々
に対する不定形情報の提供システム

補正をする者

特許出願人

(510)株式会社 日立製作所

代理人

東京都千代田区丸の内一丁目5番1号

株式会社日立製作所内 電話 東京 212-1111 (代)

(6650) 弁護士 小川勝男

補正命令の日付 平成 1 年 5 月 30 日 (発送日)

補正の対象 図面の全図

補正の内容
願書に最初に添付した図面の全図の浄書・別紙のとおり
(内容に変更なし)



以上

式
番

IN THE UNITED STATES PATENT AND TRADEMARK OFFICE

In Re: REQUEST FOR REEXAMINATION OF U.S. PATENT NO. 6,700,602

Patentee : Scott Blair

Patent No. : 6,700,602 – Issued 03/2/2004

Appl. No. : 09/423,284

Filed : May 6, 1998

For : SUBWAY TV MEDIA SYSTEM

Examiner : Chris Kelley



27299

PATENT TRADEMARK OFFICE

CERTIFICATE OF ELECTRONIC (EPS-WEB) TRANSMISSION

I hereby certify that this correspondence is being transmitted via the Office electronic filing system in accordance with 37 C.F.R. § 1.8(a)(1)(C) from the Pacific Time Zone of the United States on the local date shown below.

August 16, 2011

(Date)

[Handwritten signature]

Peter J. Gutierrez III, Reg. No. 56,732

5

STATEMENT IN SUPPORT OF REQUEST FOR REEXAMINATION OF U.S. PATENT NO. 6,700,602

10

Mail Stop *Ex Parte* Reexam
Commissioner for Patents
P.O. Box 1450
Alexandria, VA 22313-1450

15

Dear Sir:

This is a request for ex parte reexamination of U.S. Patent No. 6,700,602. It is being accompanied by form SB57, form SB42 citing four (4) references, copies of the four (4) references and translations where necessary, a copy of the subject patent in double column format and the required fee.

20

1. Identification of Requestor

Reexamination of U.S. Patent No. 6,700,602 (hereinafter“the ‘602 Patent’), is respectfully requested by Peter J. Gutierrez, (hereinafter“Requestor”).

The Requestor submits that the enclosed prior art, identified on the attached SB42 form,
5 is pertinent and applicable to the ‘602 Patent.

2. Identification of Claims for Which Reexamination is Requested

In accordance with 37 C.F.R. § 1.510, reexamination of Claim 1 of the ‘602 Patent is requested by the Patent Owner in view of the following references, hereinafter collectively
10 referred to as “the New References”, a copy of each of the following being attached to this Request.

- Japanese Publication of Unexamined Patent Application No. 61-272668 (hereinafter“D1”);
- Japanese Patent Application Publication No. H2-223985 (hereinafter“D2”);
- 15 • Japanese Published Unexamined Patent Application No. H04-160991 (hereinafter“D3”); and
- Japanese Patent Application No. S61-285490 (hereinafter“D4”).

Reexamination of Claim 1 is requested in view of the New References.
20

3. Statement of Each Substantial New Question of Patentability

A. A substantial new question of patentability as to Claim 1 is raised by the References

Claim 1 of the ‘602 Patent was granted in a Notice of Allowance on November 17, 2003.
25 In the Notice of Allowance, the Office indicated that none of Gerke, Steventon, nor Williams (considered by the Office during prosecution of the ‘602 Patent) disclose the combination of:

30 *“a subway car for mass transportation including longitudinal opposed sidewalls, a ceiling adjoining the sidewalls, a video display system comprising a*

5 *"a subway car for mass transportation including longitudinal opposed
sidewalls, a ceiling adjoining the sidewalls, a video display system comprising a
plurality of video display monitors each having a vide screen, and a video signal
source unit operatively connected to said monitors, said monitors being spaced
10 along the length of the car on opposed sides thereof, each of said monitor being
mounted at the junction of the sidewall and ceiling, with the screen of the monitor
substantially flushed with the adjacent wall surface structure of the car, and
directed obliquely downwardly toward the car seats, so that each video screen is
readily visible to passengers in the subway car."*

10 Accordingly, the references of record do not teach or suggest such features, as recited in
Claim 1.

15 In Patent Owner's Office Action response dated October 10, 2003, Patent Owner had
asserted that: *"Williams is directed to a system that can be removed from a seat of an airplane
.... This similarly applies to Steventon, since this reference relates to the mounting of monitors
in the back of seats in an airplane."* However, the New References show various video monitor
systems that are used in applications, such as on train cars. These teachings provided by the
New References were not present during the prior examination of the '602 Patent, and as such,
these teachings are new.

20 In addition, in Patent Owner's Office Action response dated October 10, 2003, Patent
Owner had argued in part that: *"Williams fails to overcome the recognized deficiencies of Gerke
and Steventon because Williams does not disclose ... securing a monitor to the junction between
the ceiling and an adjacent wall"*. However, as will be discussed more fully below, D2 appears
to teach *"information signal display devices"* mounted near the junction of the sidewall and
25 ceiling (see Figures 4 to 6 of D2). These teachings provided by the New References were not
present during the prior examination of the '602 Patent, and as such, these teachings are new.

30 The Patent Owner believes that a reasonable Examiner would consider such teachings
important in determining whether or not Claim 1 is patentable. For this reason, the combined
teachings of the New References and the references of record raise a substantial new question of
patentability with respect to at least independent Claim 1.

4. Detailed Explanation Under 37 C.F.R. § 1.510(b)

A. Claim 1 of U.S. Patent No. 6,700,602

The New References

<p>1. A subway car for mass transportation including longitudinal opposed sidewalls, a ceiling adjoining the sidewalls,</p>	<p>D3 teaches a "car body" for "an electric train" that include longitudinally opposed sidewalls with a ceiling that adjoins the sidewalls. (page 738 and Fig. 2)</p>
<p>a video display system comprising a plurality of video display monitors each having a video screen, and</p>	<p>D1 teaches "information systems that can selectively display a variety of multifunctional information in stations, in between stations, or in train cars which are underway" (page 588). D1 also teaches multiple "Information communication display parts" (page 590 and FIG. 2).</p>
<p>a video signal source unit operatively connected to said monitors,</p>	<p>D1 teaches "A video switcher which is an image signal switching device; (2) An image memory; (3) A video disk device which facilitates selection and playback of the desired images by means of external signals via the controller; (4) A video tape recorder via the controller; (5) Videodisc players which are installed in stations or train cars." (page 588).</p>
<p>said monitors being spaced along the length of the car on opposed sides thereof,</p>	<p>D2 appears to teach information signal display devices disposed on opposing sides of the train (Figures 4 to 6). D3 appears to teach "television receivers" spaced along the length of the "car body" (Fig. 2) D4 teaches "the display devices 21 to 2n are arranged on the walls flanking the aisles of each train or above the windows of the passenger seats" (page 621).</p>
<p>each of said monitor being mounted at the junction of the sidewall and ceiling,</p>	<p>D2 appears to teach "information signal display devices" mounted near the junction of the sidewall and ceiling (Figures 4 to 6)</p>
<p>with the screen of the monitor substantially flushed with the adjacent wall surface structure of the car, and</p>	<p>None of the References teaches or suggests the monitor being substantially flushed with the adjacent wall surface structure of the car.</p>
<p>directed obliquely downwardly toward the car</p>	<p>D2 appears to teach "information signal</p>

seats, so that each video screen is readily visible to passengers in the subway car.	<i>display devices</i> " that are downwardly directed. (Figures 4 to 7)
--	---

5. Remarks

Despite the substantial new question of patentability ostensibly introduced by the teachings of the New References, Patent Owner still believes Claim 1 is patentable over the New References (and the references of record) in that, *inter alia*, the New References fail to teach or suggest a "subway car...with the screen of the monitor substantially flushed with the adjacent wall surface structure of the car". As set forth in Patent Owner's Office Action response dated October 10, 2003, "*Gerke and Steventon fail to disclose a video monitor screen that is substantially flush with the adjacent wall.*"

Furthermore, Patent Owner had argued that Williams failed "to overcome the recognized deficiencies of Gerke and Steventon because Williams does not disclose a video monitor screen that is substantially flush to the adjacent wall as asserted by the Examiner". As noted above, the New References fail to address these deficiencies that were also present in the art of record, as discussed in Patent Owner's Office Action response dated October 10, 2003.

6. Conclusion

Thus, for the reasons set forth above, at least one substantial new question of patentability has been raised with respect to Claim 1 of the '602 Patent based on the New References, which were not of record during the prosecution of the '602 Patent. However, based on the reasons set forth above, it is believed that Claim 1 (and therefore its dependent claims) is/are patentable over both the New References and the art of record.

Accordingly, reexamination of Claim 1 of the '602 Patent, and the issuance of a certificate confirming patentability, is respectfully requested.

U.S. Patent No. : 6,700,602
Application No.: 09/423,284
Request for Reexamination

If the Office has any questions or comments which may be resolved over the telephone, they are invited to call the undersigned at (858) 675-1670.

Respectfully submitted,

GAZDZINSKI & ASSOCIATES, PC

5

10 Dated: August 16, 2011

By: 

Peter J. Gutierrez, III
Registration No. 56,732
16644 West Bernardo Dr., Suite 201
San Diego, CA 92127
Telephone No.: (858) 675-1670
Facsimile No.: (858) 675-1674

15

Under the Paperwork Reduction Act of 1995, no persons are required to respond to a collection of information unless it displays a valid OMB control number.

(Also referred to as FORM PTO-1465)

REQUEST FOR EX PARTE REEXAMINATION TRANSMITTAL FORM

Address to:

Mail Stop *Ex Parte* Reexam
Commissioner for Patents
P.O. Box 1450
Alexandria, VA 22313-1450

Attorney Docket No.: BLAIR.001A

Date: August 16, 2011

1. This is a request for *ex parte* reexamination pursuant to 37 CFR 1.510 of patent number 6,700,602 issued March 2, 2004. The request is made by:
 patent owner. third party requester.
2. The name and address of the person requesting reexamination is:
Scott Blair
1 Toronto Street, Suite 910
Toronto, M5C 2V6
3. a. A check in the amount of \$_____ is enclosed to cover the reexamination fee, 37 CFR 1.20(c)(1);
 b. The Director is hereby authorized to charge the fee as set forth in 37 CFR 1.20(c)(1) to Deposit Account No. 501423; or
 c. Payment by credit card. Form PTO-2038 is attached.
4. Any refund should be made by check or credit to Deposit Account No. 501423 37 CFR 1.26(c). If payment is made by credit card, refund must be to credit card account.
5. A copy of the patent to be reexamined having a double column format on one side of a separate paper is enclosed. 37 CFR 1.510(b)(4)
6. CD-ROM or CD-R in duplicate, Computer Program (Appendix) or large table
 Landscape Table on CD
7. Nucleotide and/or Amino Acid Sequence Submission
If applicable, items a. – c. are required.
a. Computer Readable Form (CRF)
b. Specification Sequence Listing on:
i. CD-ROM (2 copies) or CD-R (2 copies); or
ii. paper
c. Statements verifying identity of above copies
8. A copy of any disclaimer, certificate of correction or reexamination certificate issued in the patent is included.
9. Reexamination of claim(s) 1 is requested.
10. A copy of every patent or printed publication relied upon is submitted herewith including a listing thereof on Form PTO/SB/08, PTO-1449, or equivalent.
11. An English language translation of all necessary and pertinent non-English language patents and/or printed publications is included.

[Page 1 of 2]

This collection of information is required by 37 CFR 1.510. The information is required to obtain or retain a benefit by the public which is to file (and by the USPTO to process) an application. Confidentiality is governed by 35 U.S.C. 122 and 37 CFR 1.11 and 1.14. This collection is estimated to take 2 hours to complete, including gathering, preparing, and submitting the completed application form to the USPTO. Time will vary depending upon the individual case. Any comments on the amount of time you require to complete this form and/or suggestions for reducing this burden, should be sent to the Chief Information Officer, U.S. Patent and Trademark Office, U.S. Department of Commerce, P.O. Box 1450, Alexandria, VA 22313-1450. DO NOT SEND FEES OR COMPLETED FORMS TO THIS ADDRESS.
SEND TO: Mail Stop *Ex Parte* Reexam, Commissioner for Patents, P.O. Box 1450, Alexandria, VA 22313-1450.

If you need assistance in completing the form, call 1-800-PTO-9199 and select option 2.

Under the Paperwork Reduction Act of 1995, no persons are required to respond to a collection of information unless it displays a valid OMB control number.

12. The attached detailed request includes at least the following items:
- a. A statement identifying each substantial new question of patentability based on prior patents and printed publications. 37 CFR 1.510(b)(1)
 - b. An identification of every claim for which reexamination is requested, and a detailed explanation of the pertinency and manner of applying the cited art to every claim for which reexamination is requested. 37 CFR 1.510(b)(2).

13. A proposed amendment is included (only where the patent owner is the requester). 37 CFR 1.510(e)

14. a. It is certified that a copy of this request (if filed by other than the patent owner) has been served in its entirety on the patent owner as provided in 37 CFR 1.33(c).

The name and address of the party served and the date of service are:

Date of Service: _____; or

b. A duplicate copy is enclosed because service on patent owner was not possible. An explanation of the efforts made to serve patent owner **is attached**. See MPEP 2220.

15. Correspondence Address: Direct all communications about the reexamination to:

The address associated with Customer Number:

27299

OR

Firm or Individual Name _____

Address _____

City _____

State _____

Zip _____

Country _____

Telephone _____

Email _____

16. The patent is currently the subject of the following concurrent proceeding(s):

- a. Copending reissue Application No. _____
- b. Copending reexamination Control No. _____
- c. Copending Interference No. _____
- d. Copending litigation styled: _____

WARNING: Information on this form may become public. Credit card information should not be included on this form. Provide credit card information and authorization on PTO-2038.

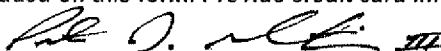

Authorized Signature

Peter J. Gutierrez, III

Typed/Printed Name

August 16, 2011

Date

56,732

Registration No.

For Patent Owner Requester

For Third Party Requester



US006700602B1

(12) **United States Patent Blair**

(10) **Patent No.: US 6,700,602 B1**
(45) **Date of Patent: Mar. 2, 2004**

(54) **SUBWAY TV MEDIA SYSTEM**
(76) Inventor: **Scott Blair**, 32 Marlow Avenue, Toronto, Ontario (CA), M4J 3T9
(*) Notice: Subject to any disclaimer, the term of this patent is extended or adjusted under 35 U.S.C. 154(b) by 0 days.

4,647,980 A	3/1987	Steventon et al.	348/837
5,009,384 A *	4/1991	Gerke et al.	248/343
5,059,957 A	10/1991	Todoriki et al.	345/7
5,123,728 A	6/1992	Gradin et al.	353/78
5,229,910 A	7/1993	Kasahara	361/234
5,463,827 A	11/1995	Williams	40/449
5,606,154 A	2/1997	Doigan et al.	
5,666,291 A *	9/1997	Scott et al.	709/250
5,854,591 A *	12/1998	Atkinson	725/76
6,038,426 A *	3/2000	Williams, Jr.	725/77

(21) Appl. No.: **09/423,284**
(22) PCT Filed: **May 6, 1998**
(86) PCT No.: **PCT/CA98/00439**
§ 371 (c)(1),
(2), (4) Date: **Feb. 22, 2000**
(87) PCT Pub. No.: **WO98/51081**
PCT Pub. Date: **Nov. 12, 1998**

FOREIGN PATENT DOCUMENTS

CA	2089382	12/1992
CA	1316253	4/1993
CA	2183277	2/1997
EP	0 577 054	1/1994
FR	2652701 A1	4/1991

* cited by examiner

Primary Examiner—Chris Kelley
Assistant Examiner—Allen Wong

Related U.S. Application Data
(60) Provisional application No. 60/045,811, filed on May 7, 1997.

(74) *Attorney, Agent, or Firm*—Nixon Peabody LLP; Jeffrey L. Costellia

(51) **Int. Cl.**⁷ **H04N 7/18; H04N 5/64**
(52) **U.S. Cl.** **348/61; 348/837**
(58) **Field of Search** 348/61, 837; 709/250; 725/46; 726/77; 248/343

(57) **ABSTRACT**

A television system for subway cars (10) includes a plurality of TV monitors (22) mounted at intervals along the cars (10), at the junction of the sidewall and the ceiling, and a central video signal source unit (23) such as a video tape player, video disk player, computer-based digital video recorder or television receiver, connected to the video monitors (22). Programs of short duration, e.g. 5–15 minutes, matching the average length of a subway ride, and comprising advertising messages, news bytes and the like are played and displayed in the monitors repeatedly during the subway ride.

(56) **References Cited**
U.S. PATENT DOCUMENTS
1,894,684 A 1/1933 Hawk 40/593
3,182,550 A 5/1965 Goldine 353/13
3,457,006 A 7/1969 Brown et al. 352/132
4,073,368 A 2/1978 Mustapick 186/53
4,352,124 A 9/1982 Kline 348/61
4,630,821 A 12/1986 Greenwald 463/1

7 Claims, 6 Drawing Sheets

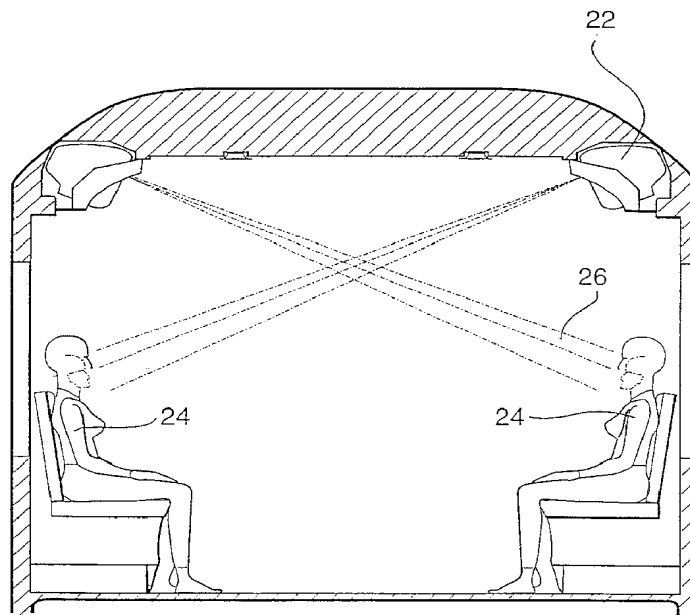

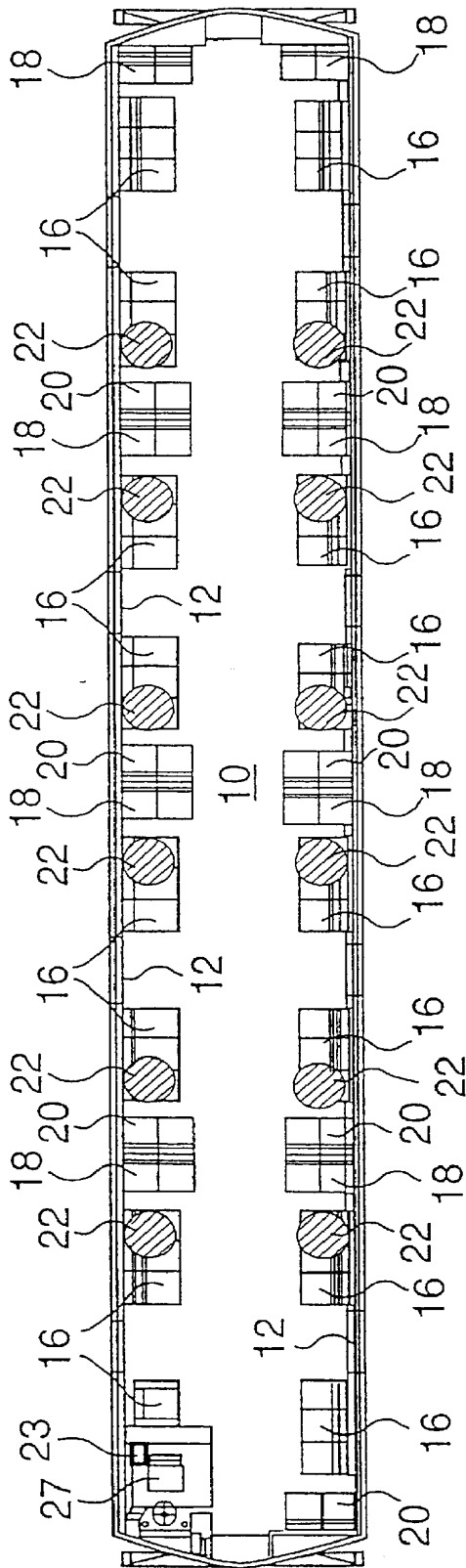

FIG. 1a

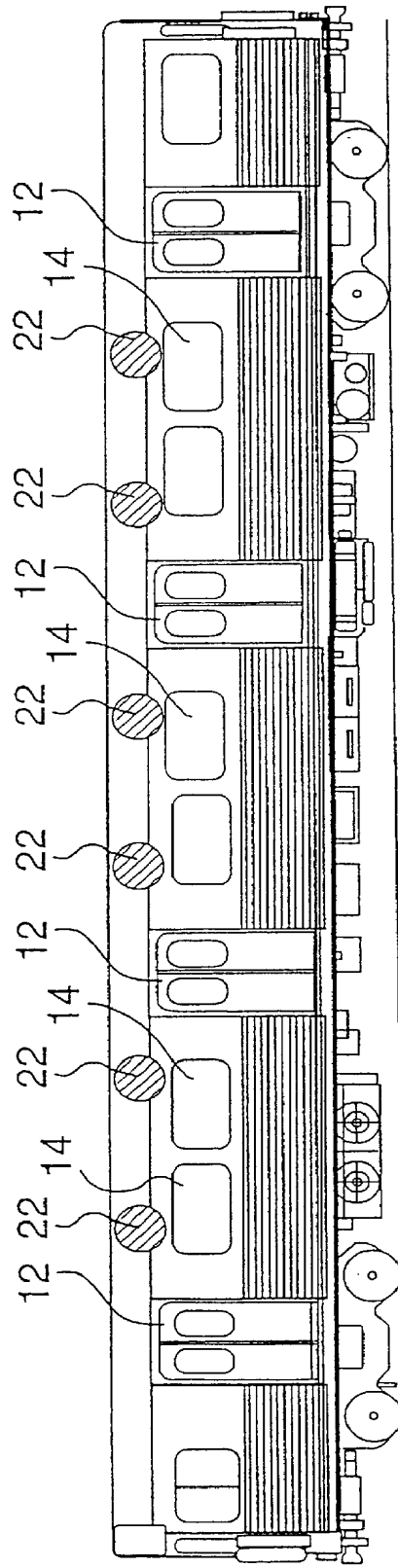

FIG. 1b

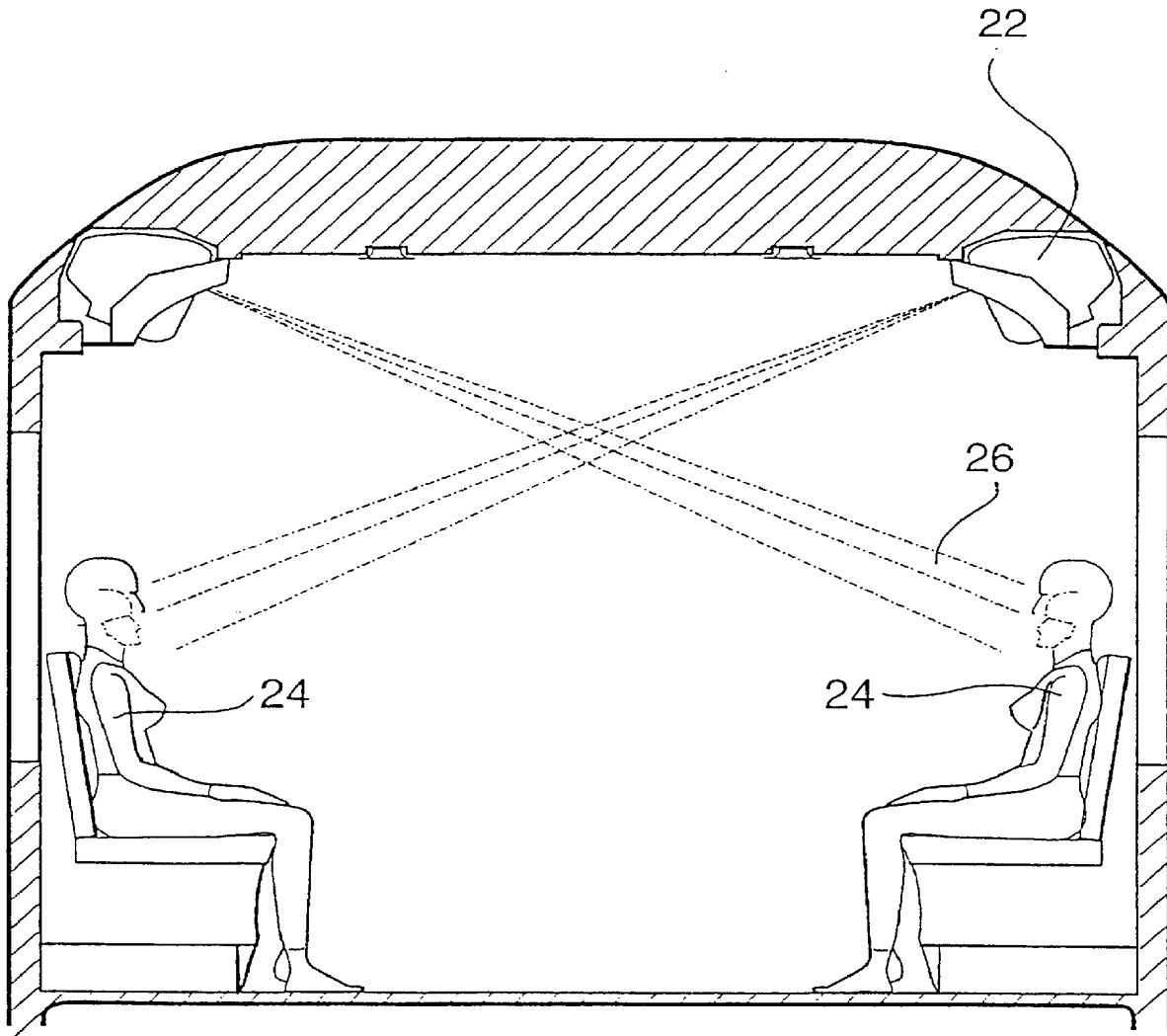

FIG. 2

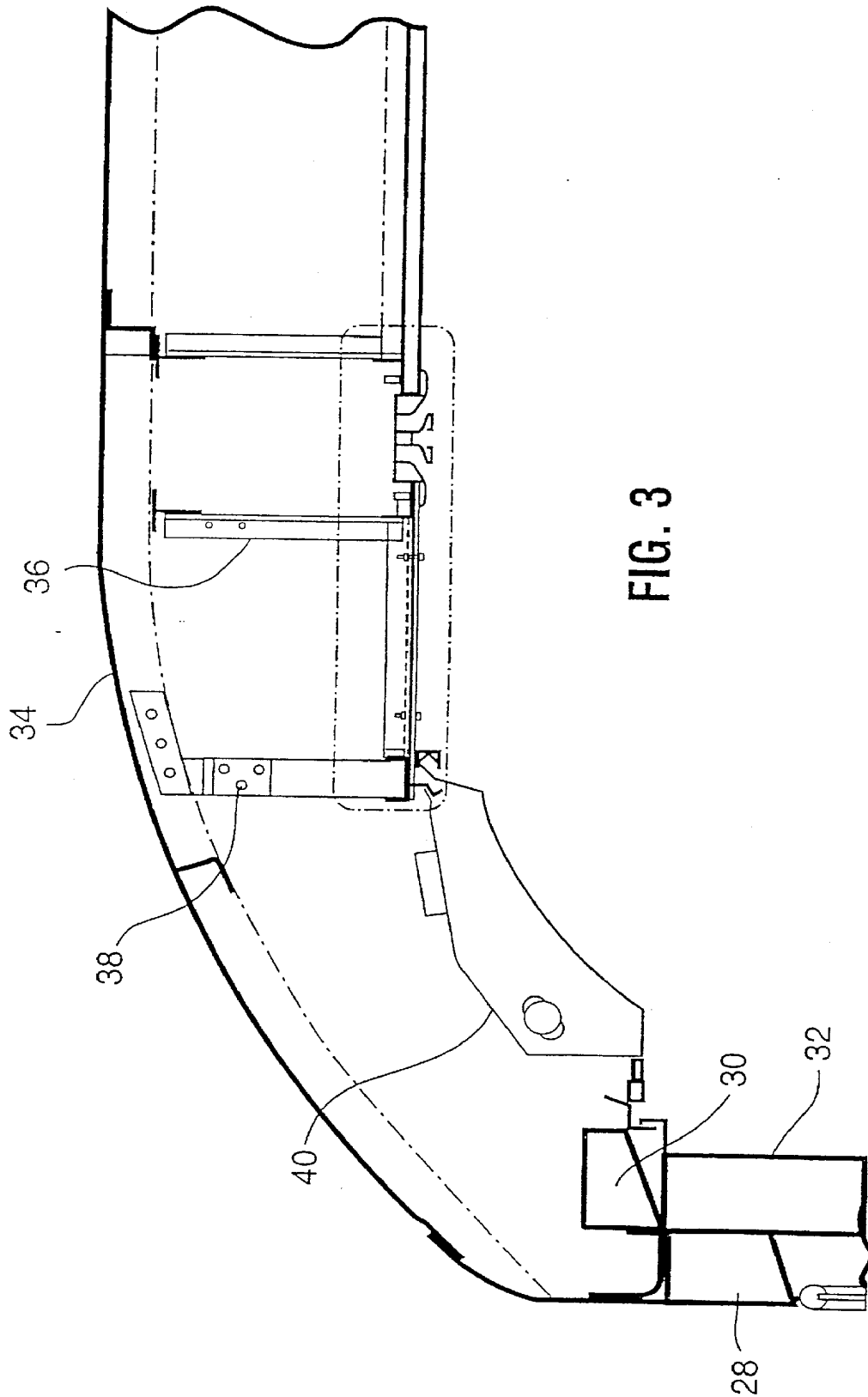

FIG. 3

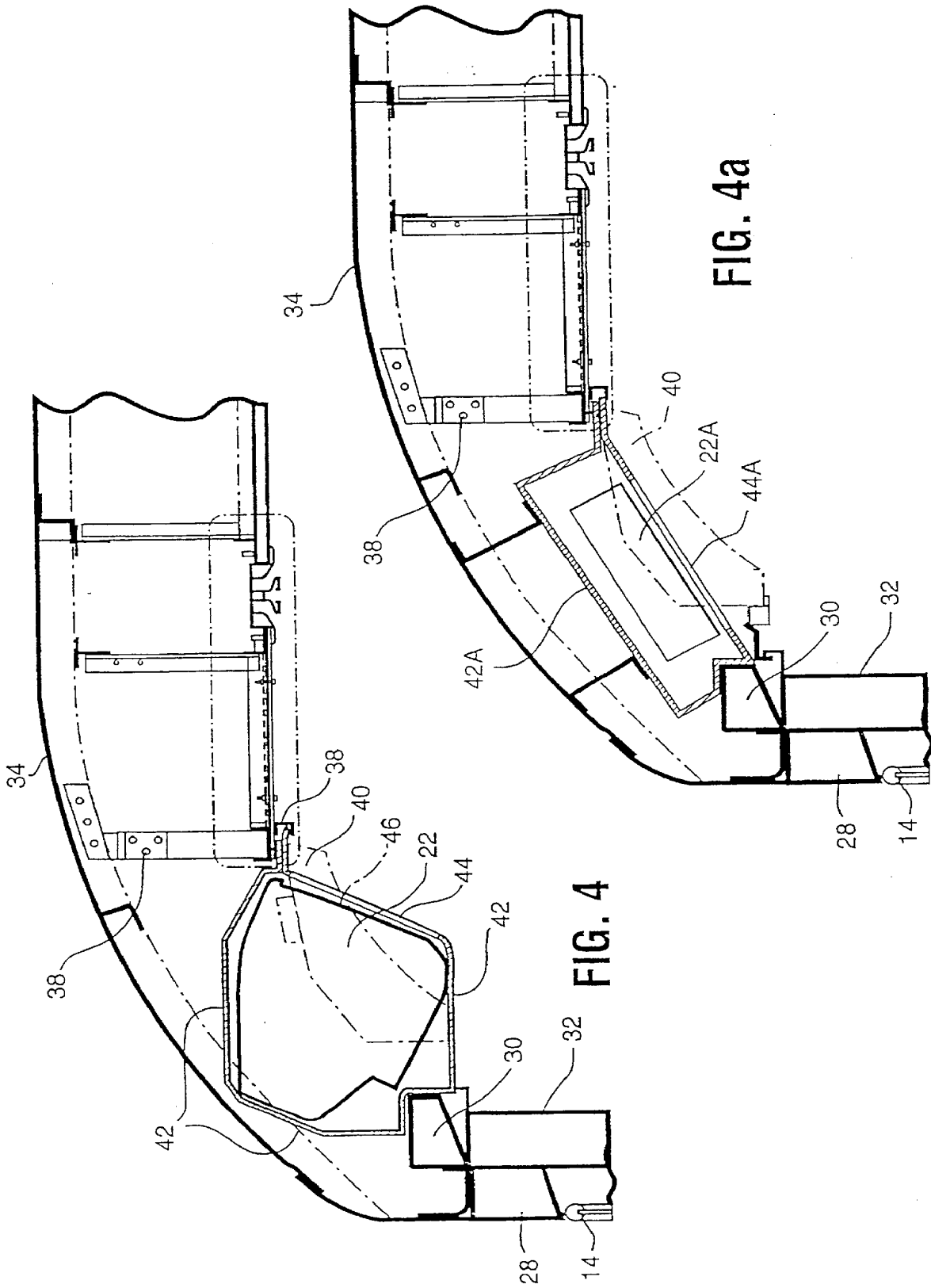

FIG. 4

FIG. 4a

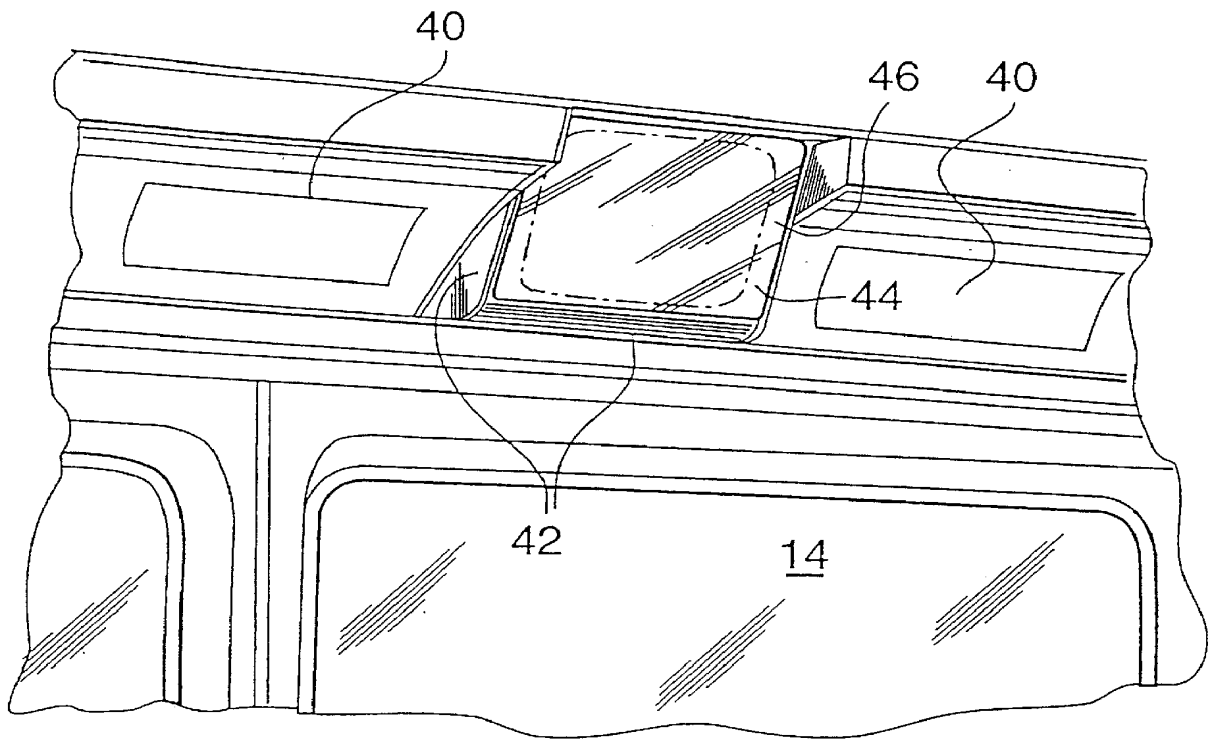

FIG. 5

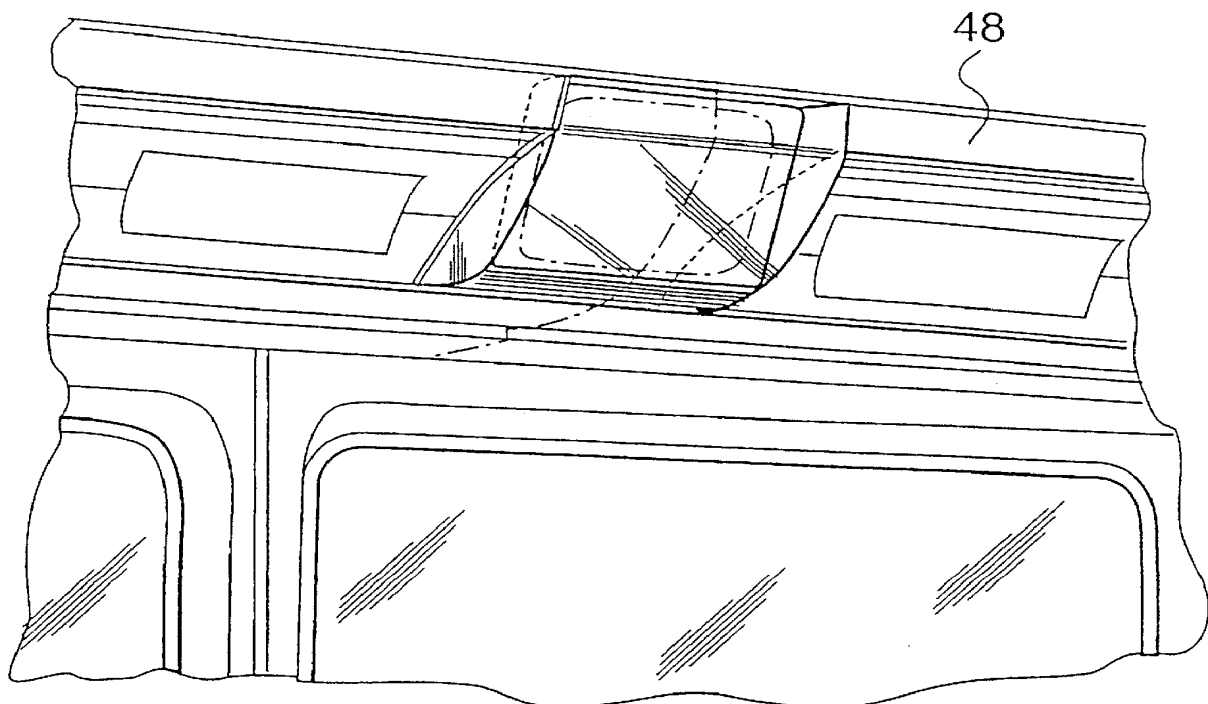

FIG. 6

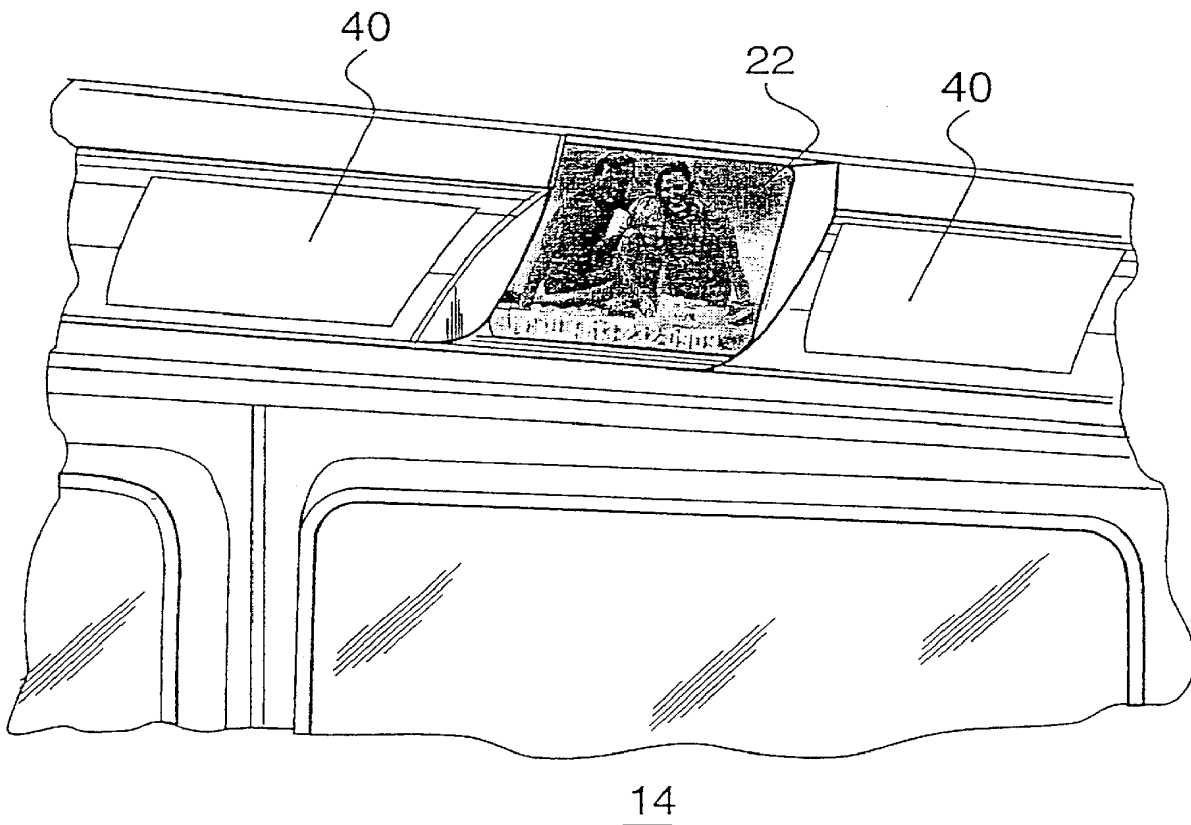

FIG. 7

SUBWAY TV MEDIA SYSTEM

This application claims benefit of provisional application Serial No. 60/045,811, filed May 7, 1997.

This invention relates to video display systems, and more specifically to video display systems mounted in and operating in mass transit subway cars.

It is commonplace to provide visual advertising displays such as posters in mass transit subway cars, where the displays are available for reading by subway passengers during travel. It is also known to equip subway cars with closed circuit television cameras, for surveillance of passenger behaviour and other safety checks. Images of such surveillance are either displayed at a central security facility, or recorded for subsequent viewing in the event of safety problems.

It is also commonplace to equip subway cars with audio public address systems for a myriad of uses, including transit service announcements, community service events, advertising, safety and emergency procedures, as well as inter-staff communications.

Proposals have been made previously to equip other transportation items, especially aircraft, with television or video systems, primarily for the entertainment of passengers on long journeys. Examples of such systems in the patent literature can be found in U.S. Pat. No. 4,647,980 Steventon et al., U.S. Pat. No. 4,630,821 Greenwald, U.S. Pat. No. 4,352,124 Kline, U.S. Pat. No. 5,123,728 Gradin et al., and U.S. Pat. No. 3,457,006 Brown et al.

Entertainment of passengers on subway cars has until now generally been ignored, since the average journey taken by a passenger on a mass transit subway system is usually short, lasting perhaps fifteen minutes. Nevertheless, subway transit riders offer an attractive audience for visual advertising messages, as evidenced by the proliferation of advertising signs which commonly adorn a subway car. In addition, mass transit systems such as subways are in need of extra sources of revenue, to keep passenger fare structures at an affordable level as operating costs rise, and to avoid decreased ridership as a result.

It is an object of the present invention to provide a public service message display system, entertainment system and advertising system for mass transit subway cars.

It is a further object to provide a novel source of extra revenue for a mass transit subway system.

The present invention provides a television public service message display, entertainment and advertising system for subway cars, in which television monitors are provided at spaced intervals in subway cars, to display short duration televisual entertainment and advertising features to subway riders. The system is designed so that advertising spots on it can be sold by the transit system to potential advertisers and sponsors, for extra revenues for the transit system. It takes advantage of the fact that subway riders are, for the most part, occupying a subway car under relatively crowded conditions but for only a relatively brief duration. They are looking for something on which to focus their attention during their brief ride, whilst at the same time often finding it inconvenient to open newspapers, magazines or the like under crowded circumstances and becoming bored by static advertising or other displays around them. The present invention provides properly positioned television monitors displaying moving images of news items, advertising material and the like, viewable by substantially all riders in the car, and filling their need for visual entertainment during the brief duration of their subway ride.

Thus, according to the present invention, from one aspect, there is provided a video system for displaying

televised material to passengers in a mass transit subway car, and comprising at least one video display monitor adapted for mounting inside a subway car so as to display televised materials to passengers riding therein, and a video signal source unit operatively connected to said at least one monitor.

According to a second aspect of the present invention, there is provided a subway car for mass transportation and comprising a video display system including at least one video display monitor having a video screen, the monitor being mounted in the subway car in a manner such that the video screen thereof is readily visible to passengers in the subway car, and a video signal source unit operatively connected to said at least one monitor.

The term "video signal source unit" as used herein embraces player units for playing pre-recorded video material, such as computer-based digital video recorders (including CD-ROM players), video tape players and video disk players, and television receivers for receiving live or pre-recorded broadcast television signals from a remote transmitter and supplying these to the video display monitors mounted in the subway cars. One system according to the invention utilizes receivers including computer-based digital video recorders for receiving broadcast television signals from a remote transmitter as the video signal source unit. Such video signal source unit can be located either within the mass transit premises or on a remote broadcasting site. Alternatively, the invention utilizes a video tape player, a video disk player, or a computer-based digital video recorder, as the video signal source unit. The video signal source unit may be located in the same subway car as that in which the monitor or monitors are located, or in adjacent or remote cars of the same train, with the necessary operative connection between the player and the monitor(s). An individual subway car can be equipped with its own video signal source unit, connected to a plurality of monitors mounted at different, appropriately chosen locations along the length of the subway car. Alternatively, one central video signal source unit can be located in one car of subway train, and connected to monitors in some or all of the cars of the train, to provide a central video signal source unit for the train.

Computer (PC) based digital video recorders basically transmit video signals from a hard drive or CD-ROM storage. They are however also capable of receiving transmitted input at intervals, e.g. news item updates, at, say, hourly intervals, to add to their stored transmittable video data. In this sense they also act as television receivers.

The video signal source unit and video display monitors used in the present invention can be of known, standard form, obtainable as off the shelf items from manufacturers and sales outlets. The connections between them, for display of televised material, are also standard and well within the skill of the art. For example, use can be made of the existing subway infrastructure by which audio announcements are currently transmitted. Alternatively, the connections may be by use of coaxial cables, fibre optics, cell phone systems or satellite transmission, or by other appropriate means.

A preferred system according to the invention is a subway car or plurality of subway cars equipped with a plurality of television monitors, especially LCD-based television monitors, and a video signal source comprising a video tape player, video disk player or computer-based digital video recorder, the video signal source and the monitors being interconnected by suitable electrical cable systems which are self-contained within the subway car. In this way, new subway cars can be built with the video system

3

or parts thereof installed, and usable on substantially any transit system, since the operation of the video system is independent of any previously installed track, tunnel or control systems.

The video system according to the present invention provides a means for communicating a very wide range of information to viewers in an environment ideally suited to communicating short video messages to viewers, especially commercial messages or sponsored community service, or informational news bytes. Most subway rides are of short duration, e.g. 15–30 minutes or less. It is normally undesirable to play television programs of any significant length to subway passengers for fear of distracting them from their proper points of interchange and disembarkation on the subway system. However, the system according to the invention is ideally suited for displaying a series of short, 30 second–1 minute messages, in sequence, such as a series of commercial messages. These can range from straightforward advertising as seen on commercial television, or the type of news feed with corporate sponsorship as seen by cable television viewers, with news services provided by specialized companies in this business. If the information is delivered by video tape player, video disk player or computer-based digital video recorder, it can be repeated at intervals of, say, 5–15 minutes, based upon the average duration of individual subway rides, i.e. the pre-recorded program is of total duration of about 5–15 minutes. If the feed is delivered from an outside source, its delivery depends on the package of the server, and according to agreement between the purchaser and the mass transit management, and other interested parties as necessary.

Typically, the television images displayed by the monitors of the system according to the invention do not incorporate sound, though they may contain rolling script, similar to cable television news channels, or similar to closed-captioning for the hearing impaired. This avoids risk of interference with announcements being played to passengers through the normal audio address system carried by the subway train, and avoids adding to the general noise level experienced by passengers on the subway cars, a noise level which is commonly quite high even under normal running conditions. However, sound may be incorporated where appropriate, for example in safety or emergency situations, or to mark the beginning of a message to which the subway or transmission provider wishes to call attention.

The manner in which the video display monitors are disposed and mounted in the subway car depends to some extent on the design of the subway car itself. Such designs can vary between different subway systems. Normally from 6–12 such colour monitors are provided in each subway car, suitably of 12"–13" size, spaced along the length of the car, and disposed above the windows of the car, in a manner and at a location which does not interfere with the operation of any other essential element of the car (door operation, lights, heating, air conditioning etc.). A subway car is normally constructed so that it has a cavity wall, defined between its outer structural shell and its inner lining wall, the cavity providing for wiring and cables and other mechanical functions, and, at places, containing insulation. The video display monitors in the system of the invention are suitably mounted in the cavity wall.

In a preferred arrangement, the video display monitors have a strong metal frame construction, fixed to the frame of the subway car. The screens are preferably covered with a rigid transparent unit, e.g. of polycarbonate, shaped to coincide with the shape of the internal wall of the subway car at the location of mounting. For example, when the

4

monitor is mounted at the junction of the wall and ceiling of the subway car, where there is commonly provided a concavely curved segment of internal wall, the transparent cover unit is suitably similarly concavely curved, so that it can be mounted as a continuum with the internal walls and blended to contours thereof, with the monitor mounted behind it. The screen is suitably angled downwardly, for best viewing by passengers seated opposite the screen. The entire structure of the monitor, including the cover unit if used, is suitably housed in a stainless steel or strong plastic casement, designed to appear integral with the subway car, without visible edges or protuberances, and matching the materials and colours of the subway car interior.

The video monitors used in the system of the present invention can be of standard, cathode ray tube-based design. Such monitors have the advantage of economy, being mass-produced items manufactured on a very large scale. They are eminently suitable for use in most embodiments according to the invention, and can be viewed clearly from a variety of angles. However, in circumstances where the subway car in operation encounters locations of large magnetic field, it is possible that the picture displayed on a CRT monitor will be distorted as the monitor moves through such location. Any such distortion effect can be reduced by surrounding the monitor, to an extent practical and consistent with its provision of full visual display, with an appropriate shield such as a steel or other ferromagnetic casement. Where such a magnetic field problem turns out to be particularly acute, the CRT-type monitor may be replaced by a monitor incorporating a colour liquid crystal display (LCD) screen, which is not sensitive to intermittent encountering of external magnetic fields.

Specific preferred embodiments of the present invention are illustrated in the accompanying diagrammatic drawings in which:

FIG. 1 shows in plan view (FIG. 1A) and in side elevation (FIG. 1B), an existing subway car as used on the Toronto Transit System with indications of appropriate locations for mounting video monitors according to the invention;

FIG. 2 is a sectional view of a subway car according to the invention with video monitors in place;

FIG. 3 is a detail, in section, of an existing subway car illustrating the location for receiving a video monitor according to the invention;

FIG. 4 is a detail similar to FIG. 3, with the video monitor in place;

FIG. 4A is a view, similar to FIG. 4, of an alternative embodiment;

FIG. 5 is a detail in perspective view, of a subway car equipped with a monitor according to one embodiment of the invention;

FIG. 6 is a detail similar to FIG. 5 but of a further alternative embodiment;

FIG. 7 is a view similar to FIG. 6, showing the general appearance when the monitor is operating.

A typical subway car 10, as illustrated in FIGS. 1A and 1B, is equipped with sliding doors 12 and windows 14, spaced at convenient intervals along the length of the car. Passenger seats, in sets of 2's and 3's, are disposed beneath and alongside the windows 14, clear of the doors 12, some sets 16 being inward facing, other sets 18 being forward facing and other sets 20 being rearward facing.

Suitable locations for video monitors 22 in accordance with the invention are at the junction of wall and ceiling of subway car 10, above the windows 14 and clear of the doors 12. They are thus disposed opposite to sets of inward facing

5

seats 16, and angled downwardly for ease of viewing of passengers 24 seated in such inward facing seats 16, as shown in FIG. 2, with direct sight lines. 26, but visible to passengers seated elsewhere, and standing in the car 10. A video player 23 is suitably located in the driver's cab 27 (FIG. 1A), and connected to all the monitors 22 by cables (not showing) disposed in the cavity walls of the car.

FIG. 3 shows a detail of the car 10, at the location where a monitor 22 is to be installed. The car wall has an outer shell 28 in which windows 14 are sealingly mounted, and structural pillars 30 mounted at intervals and secured to the vertical structural member 32. Centrally secured to the exterior skin and body structure of body 34 of the car is a main air duct 36 and a housing 38 carrying ceiling lights running substantially the full length of the car 10. The space between the ceiling housing 38 and the top of the pillars 30 is normally occupied by back lit advertising panels 40. Removal of appropriate portions of these panels 40 provides space for location of video monitors 22, according to the preferred embodiment of the invention.

Thus as shown in FIG. 4, the video monitor 22 is enclosed and rigidly mounted in its own enclosure 42, of stainless steel, rigid plastic or the like. The enclosure in turn is secured to the top of structural pillar 30 and the side of housing 38, in a space between the ends of illuminated panels 40, and protruding rearwardly to a position adjacent the outer part of the exterior skin and body structure 34. The front wall of enclosure 42 is comprised of a clear transparent polycarbonate shield 44, through which the screen 46 the monitor 22 is clearly visible. The screen 46 is angled downwardly for best viewing by a passenger 24 seated opposite. The enclosure 42 with monitor 22 therein and connections protruding outwardly therethrough is removable as a unit, for replacement or service.

An alternative embodiment is illustrated in FIG. 4A, a view similar to that of FIG. 4. In this alternative embodiment, CRT video monitor 22 is replaced with an LCD-based video monitor 22A which is of thin, rectangular cross-section, and occupies less space in the ceiling structure of the car. Accordingly, it can be moved towards the ceiling so that its viewing screen is substantially flush with or even behind the light panel 40. This use of an LCD-based monitor gives a better aesthetic appearance to the inside of the subway car as a whole, as well as improving the display performance by minimizing the interference effects, as previously discussed. An appropriately shaped enclosure 42A for the LCD-based monitor, with transport screen 44A, replaces enclosure 42 for the CRT video monitor, and is similarly mounted in place.

FIG. 5 shows a front, perspective view of the arrangement shown in section in FIG. 4. The monitor 22 and its covering shield 44 are recessed behind the upper portion of the adjacent advertising panels 40, and the sides of the enclosure 42 protrude inwardly from the lower portion of panels 40. This provides ease of access to the enclosure 42 for its removal when necessary.

An alternative arrangement is shown in FIG. 6. Here the polycarbonate shield 44 is convexly curved, and is disposed further forward from the monitor screen 44. The shield 44 now blends with forward facing part 48 the exterior skin and body structure 34, to provide a perhaps more aesthetically appealing arrangement. In FIG. 7, there is diagrammatically

6

illustrated the arrangement of FIG. 6 in practical operation. Poster-type illuminated advertisements are provided by advertising panels 40 flanking the video monitors 22, whilst the video monitor 22, disposed at intervals along the length of the car 10, show video information and/or advertising spots, at convenient, easily viewed locations and disposition to passengers riding in the car 10.

It will be appreciated that the specific embodiments illustrated and described herein are by way of example only, and are not to be construed as limiting on the scope of the invention. The description pertains specifically to the type of subway car currently in use in the Toronto Transit System, and illustrates a means and location for mounting the video monitors in such a system. Details of construction, and hence details of appropriate mounting for video monitors may differ from subway system to subway system according to the form of car in use. Such mounting details do not depart from the scope of the present invention. In all cases, it is contemplated that a plurality of monitors will be provided in each car, each rigidly mounted at a convenient location clear of the doors and windows, and at a disposition where it can be viewed by passengers riding the subway car, without difficulty. The provision of such video monitors mounted in their own enclosures as described herein, and faced with a transparent screen of, for example, polycarbonate, allows for considerable variation in the detail of mounting means and locations, to adapt them to different constructions of subway cars currently in use on different mass transit systems.

What is claimed is:

1. A subway car for mass transportation including longitudinal opposed sidewalls, a ceiling adjoining the sidewalls, a video display system comprising a plurality of video display monitors each having a video screen, and a video signal source unit operatively connected to said monitors,

said monitors being spaced along the length of the car on opposed sides thereof, each of said monitor being mounted at the junction of the sidewall and ceiling, with the screen of the monitor substantially flushed with the adjacent wall surface structure of the car, and directed obliquely downwardly toward the car seats, so that each video screen is readily visible to passengers in the subway car.

2. The subway car of claim 1 wherein the video signal source system includes a pre-recorded video transmission program for feeding to display on the monitors of duration about 5-15 minutes.

3. The subway car of claim 1 wherein the program is repeatable, and includes a series of commercial messages of 30 second-1 minute duration.

4. The video system subway car of claim 1 which is sound free.

5. The subway car of claim 1 wherein the video signal source unit comprises a video tape player, a video disk player or computer-based digital video recorder.

6. The subway car of claim 1 wherein the video monitors include LCD screens.

7. The subway car of any of claim 1 including a self-contained wiring-cabling system connecting the video monitors to the video signal source unit.

* * * * *

Electronic Patent Application Fee Transmittal

Application Number:				
Filing Date:				
Title of Invention:	SUBWAY TV MEDIA SYSTEM			
First Named Inventor/Applicant Name:	Scott Blair			
Filer:	Robert F. Gazdzinski			
Attorney Docket Number:	BLAIR.001A			
Filed as Large Entity				
ex parte reexam Filing Fees				
Description	Fee Code	Quantity	Amount	Sub-Total in USD(\$)
Basic Filing:				
Request for ex parte reexamination	1812	1	2520	2520
Pages:				
Claims:				
Miscellaneous-Filing:				
Petition:				
Patent-Appeals-and-Interference:				
Post-Allowance-and-Post-Issuance:				
Extension-of-Time:				

Description	Fee Code	Quantity	Amount	Sub-Total in USD(\$)
Miscellaneous:				
Total in USD (\$)				2520

Electronic Acknowledgement Receipt

EFS ID:	10751489
Application Number:	90011861
International Application Number:	
Confirmation Number:	3736
Title of Invention:	SUBWAY TV MEDIA SYSTEM
First Named Inventor/Applicant Name:	Scott Blair
Customer Number:	27299
Filer:	Robert F. Gazdzinski
Filer Authorized By:	
Attorney Docket Number:	BLAIR.001A
Receipt Date:	16-AUG-2011
Filing Date:	
Time Stamp:	19:55:49
Application Type:	Reexam (Patent Owner)

Payment information:

Submitted with Payment	yes
Payment Type	Deposit Account
Payment was successfully received in RAM	\$2520
RAM confirmation Number	6084
Deposit Account	501423
Authorized User	

The Director of the USPTO is hereby authorized to charge indicated fees and credit any overpayment as follows:

Charge any Additional Fees required under 37 C.F.R. Section 1.16 (National application filing, search, and examination fees)

Charge any Additional Fees required under 37 C.F.R. Section 1.17 (Patent application and reexamination processing fees)

Charge any Additional Fees required under 37 C.F.R. Section 1.19 (Document supply fees)

Charge any Additional Fees required under 37 C.F.R. Section 1.20 (Post Issuance fees)

Charge any Additional Fees required under 37 C.F.R. Section 1.21 (Miscellaneous fees and charges)

File Listing:

Document Number	Document Description	File Name	File Size(Bytes)/ Message Digest	Multi Part /.zip	Pages (if appl.)
1	Foreign Reference	D1.pdf	234417	no	5
			4a39ac710889e1233e8387d178949f0a9c23a206		

Warnings:

Information:

2	Foreign Reference	D2.pdf	378819	no	8
			860faa935aa25b490d8c1bba23b80c3c4e6d6a2c		

Warnings:

Information:

3	Foreign Reference	D3.pdf	474060	no	9
			1c20761790f1478325eea0592969db6a1cfa0d096		

Warnings:

Information:

4	Foreign Reference	D4.pdf	214074	no	5
			33d73d110b28a02fb7abe7370b1007726a21d7d3		

Warnings:

Information:

5	Information Disclosure Statement (IDS) Form (SB08)	IDS.pdf	55585	no	1
			7fb400beef07187c991e4f0f532e3a1f21503c6e		

Warnings:

Information:

This is not an USPTO supplied IDS fillable form

6		JP_References.pdf	8288079	yes	27
			529217c8896a23c155e3011293078c471a75f45e		

Multipart Description/PDF files in .zip description

Document Description	Start	End
Foreign Reference	1	5
Foreign Reference	6	10
Foreign Reference	11	19

	Foreign Reference		20		27
Warnings:					
Information:					
7	Reexam Miscellaneous Incoming Letter	Statement.pdf	204285 4258a6b4c9e2ce7b978cfea4475dbe1c9105b002	no	6
Warnings:					
Information:					
8	Reexam Miscellaneous Incoming Letter	Transmittal.pdf	94404 476064a260a834015c8d16197d978f3dee6bf1	no	2
Warnings:					
Information:					
9	Reexam Miscellaneous Incoming Letter	US6700602.pdf	579943 6a77f26de3f514342eee19c86057b0fa305a0bb7	no	10
Warnings:					
Information:					
10	Fee Worksheet (SB06)	fee-info.pdf	29660 8a2c4ac0ff7581242f1adeef020a13274bccd1d0	no	2
Warnings:					
Information:					
Total Files Size (in bytes):			10553326		

This Acknowledgement Receipt evidences receipt on the noted date by the USPTO of the indicated documents, characterized by the applicant, and including page counts, where applicable. It serves as evidence of receipt similar to a Post Card, as described in MPEP 503.

New Applications Under 35 U.S.C. 111

If a new application is being filed and the application includes the necessary components for a filing date (see 37 CFR 1.53(b)-(d) and MPEP 506), a Filing Receipt (37 CFR 1.54) will be issued in due course and the date shown on this Acknowledgement Receipt will establish the filing date of the application.

National Stage of an International Application under 35 U.S.C. 371

If a timely submission to enter the national stage of an international application is compliant with the conditions of 35 U.S.C. 371 and other applicable requirements a Form PCT/DO/EO/903 indicating acceptance of the application as a national stage submission under 35 U.S.C. 371 will be issued in addition to the Filing Receipt, in due course.

New International Application Filed with the USPTO as a Receiving Office

If a new international application is being filed and the international application includes the necessary components for an international filing date (see PCT Article 11 and MPEP 1810), a Notification of the International Application Number and of the International Filing Date (Form PCT/RO/105) will be issued in due course, subject to prescriptions concerning national security, and the date shown on this Acknowledgement Receipt will establish the international filing date of the application.

(19) Japan Patent Office
(JP)(12) **Japanese Publication of
Unexamined Patent Application (A)**

(11) Japanese Publication of Unexamined Patent Application Number

63-125984

(43) Publication date: May 30, 1988

(51) Int. Cl. ⁴	Identification codes	JPO file numbers
G09G 3/00		C-7335-5C
B 60 1L 25/02		A-7304-5H
G06F 15/21		C-7230-5B
G08G 1/12		6821-5H
5/00		6821-5H
G09F 9/00	363	A-6866-5C

Request for examination: Not yet requested: Number of claims: 3 (Total of 5 pages)

(54) Title of Invention: Transportation Information Display System

(21) Application number 61-272668

(22) Date of application November 15, 1986

(72) Inventor	Rinjiro MINESAKI	3947-56 Oyama-cho, Machida-shi, Tokyo
(72) Inventor	Hisao USHIHISA	7-5-14-201 Minami Aoyama, Minato-ku, Tokyo
(71) Applicant	Rinjiro MINESAKI	3947-56 Oyama-cho, Machida-shi, Tokyo
(71) Applicant	Hisao USHIHISA	7-5-14-201 Minami Aoyama, Minato-ku, Tokyo
(74) Agent	Masanori WADA, patent attorney	

SPECIFICATION

1. Title of Invention: Transportation Information Display System

2. Claims

(1) A transportation information display system consists of information communication display parts using video display devices; the information display part command devices are control parts which are installed in each station; an information display system which is linked to a central control part which provides overall control over the control parts; and the information communication display parts are integrated and combined into automated passenger ticket vending machines which are installed in stations.

(2) The video display device of the information display system of Claim 1 is integrated and combined into the top or bottom of an automated passenger ticket vending machine.

(3) The video display device of the information display system of Claim 1 is integrated and combined either into

the left or right or on both sides of an automated passenger ticket vending machine.

(4) A transportation information display system consists of information communication display parts using video display devices; the information display part command devices are control parts which are installed in each station; an information display system which is linked to a central control part which provides overall control over the control parts; and the information communication display parts are suspended within train cars to form advertising parts.

(5) The information communication display part using a video display device of the information display system of Claim 4 is an advertising part on both side walls of the interior of a train car.

(6) A transportation information display system consists of information communication display parts using video display devices; the information display part command devices are control parts which are installed in each station; an information display system which is linked to a central control part which provides overall control over the control parts; and the information communication display parts are

mounted on the rear walls of newspaper stands which are installed on platforms.

3. Detailed Description of the Invention

Industrial Field of Use

This invention pertains to the provision of information systems that can selectively display a variety of multifunctional information in stations, in between stations, or in train cars which are underway, and to the provision of instructional devices.

Prior Art

Conventionally, posters and announcements have frequently been used to provide information in railroad and bus stations, airports, and the like.

However, although announcements can provide information to a large number of individuals simultaneously, announcements have the shortcoming of being ephemeral and difficult to hear in noisy locations, then they are often misheard.

Moreover, although posters and the like have visual impact, their shortcoming is that they are extremely labor-intensive since their content cannot be changed in real-time and each and every poster needs to be replaced.

Naturally, the control parts G may be constituted so as to have their own broadcast functions to interrupt transmitted instructions from the central control part H.

The information communication display parts J are formed of a video display device such as a cathode ray tube or liquid crystal panel, or the like which displays not only static images, but dynamic images, as well.

The following is a description of an example of the control system of the information communication display part J made with reference to the block diagram in Fig. 5.

The control parts G which are linked to the central control part H have a control computer which has a data communications function and the control computer is linked under its control to the following devices via control communications pathways:

- (1) A video switcher which is an image signal switching device;
- (2) An image memory;
- (3) A video disk device which facilitates selection and playback of the desired images by means of external signals via the controller;
- (4) A video tape recorder via the controller;
- (5) Videodisc players which are installed in stations or train cars;
- (6) The following devices which have image production and editing functionality:

- ① Operating console

In recent years, dynamic image visual information displays have been proposed, but most of these simply involve the installation of television cathode ray tubes or other such display devices, then the content of the information thus provided has been limited.

In the future, the roles of stations in urban areas will no longer be limited to transportation hubs, and they will increasingly serve as bases for local culture.

It is therefore an objective of the present invention to establish an information provision system which is appropriate for the changing roles of stations and which is not limited to the display of static information in single stations.

Embodiments

The following is a description of the details of this invention made with reference to the figures.

As illustrated in Fig. 4, the total system of the present invention is comprised of information communication display parts J which are the terminal devices, a control part G which provides overall control over the information communication display parts J..., And a central control part H which provides overall control over the control parts G....

- ② Hard disk
- ③ Floppy disk
- ④ Printer

and other peripheral devices;

- (7) Data transmission pathways via the communications controller.

Moreover, in the channels having video switchers are:

- (1) a video memory which is linked to a control computer via the control communication path which is linked via a video signal converter;
- (2) a videodisc which is linked to the control computer via the controller and the control communication pathways;
- (3) a videotape recorder which is linked to the control computer via the controller and the control communication pathways;
- (4) image transmission pathways; which are linked to
- (5) the video display devices J which are installed in stations or train cars, and linked to the central control part H by means of the data transmission pathways and image transmission pathways.

In this way, the video display devices J... receive the channel selection signal output from the control computers

by means of the control communication pathways which are connected to the control computer, [the video display devices J....] are connected to the image signal switching device which is the video switcher that performs the function of switching channels, and each [of the video display devices J....] functions as individual display parts thereby.

Moreover, the video switcher has channels 1 ~n and, for example, n-4 video display devices may be connected to channels 5 ~n.

In this case, channel 1 is connected to image memory that the control computer can read and write via the video signal converter and, furthermore, the image memory is connected to the control communication pathway and placed under the control of the control computer.

Channel 2 is connected to the videodisc and, further, the videodisc is linked via the controller to the control communication pathway, and is placed under the control of the control computer.

Channel 3 is connected to the video tape recorder and, further, the video tape recorder is linked via the controller to the control communication pathway, and is placed under the control of the control computer.

For example, images that have been stored ahead of time in the videodisc can automatically and sequentially be played back according to a schedule that has been programmed into the control computer, and images can be created and edited using the computer and peripheral devices thereby so that this information is outputted via the primary storage devices of the image memory, etc. and the video signal converter.

Moreover, it is possible to interrupt the control computer via the data transmission pathway, to transmit dynamic images and static images via the image transmission pathway, and to display this information on the video display device, to store it to the video tape recorder or to the image memory, etc., and vice versa.

Each of these functions can be performed between the control computer of the central control part H and the control computers of each of the stations as well as between the control computer and the control computers of other stations because these functions are linked to each of the data transmission pathways.

Channel 4 is linked directly to the image transmission pathway.

Moreover, the control computer logically manages a variety of information by means of terminals (control operating consoles), hard disks, floppy disks, and other means, and [the control computer] is connected via the control communication pathways to these peripheral devices which are to be operated.

Further, data transmission pathways are connected between the other control parts G (between stations) between central control parts H (between the central control part H and stations), via communication controllers having bidirectional data communication pathway functions.

Apart from not having video display devices connected to a video switcher, the constitution of the central control part H is approximately identical to the constitution of the aforementioned control part G.

Therefore, in an operational state, by providing selection signals from the control computer to the video switcher, the various devices (image memory, videodisc device, videotape recorder) which are connected to the video switcher can transmit independent images to each of the video display devices by means of the image transmission pathways.

The display devices J that are the terminal devices which determine the system configuration of this invention may be combined and integrated and combined into the automated passenger ticket vending machines that are installed in each station, as illustrated in Fig. 1.

1 it is an automated passenger ticket vending machine, and with the operating part A serving as the automated passenger ticket vending function on the front of the vending machine 1, the vending machine 1 is provided with a coin insertion slot 2 for ¥100 coins and the like, a bill insertion slot 3 for ¥1000 bills and the like, a card insertion slot 4, fare pushbuttons 5, and a ticket and change dispenser 6.

These operating parts A are formed in the lower part 1b of the front panel of the machine unit.

Meanwhile, a space 7 by means of a stepped part is formed in the upper part 1a of the front panel of the machine unit.

This space 7 is for the insertion and integrated installation of an information transmission device J (not shown) which is a video display device.

However, the use of this part need not be restricted to this type of information transmission device J and may, for example, be used as a space in which to place pamphlets,

and may otherwise be used to integrate a variety of devices, such as card selling machines.

Furthermore, the shape of the space area 4 and the location of integration with the ticket vending machine need not be limited to the upper part illustrated, and a variety of design changes are possible.

When the operation of the vending machine 1 operating console A and the control part G are linked, an output part is provided on the operating console A side in which the changes in the leakage electrical field of the input information that is coded by the operation of each function is converted and transmitted, and a host device which reads the information which is outputted by the output part is provided on the control part C side.

Since combinations of each type of device are possible in this configuration, it is acceptable to change only those devices which are worn or are to be upgraded.

In a second embodiment, a suspended advertising part 8 is formed in a train car as illustrated in Fig. 2.

An information transmission display part J is formed of an advertising part 8 which is suspended and hangs down from the ceiling in the form of a panel advertising part 8 consisting of a panel-type such as a liquid crystal panel, or the like, within a mounting frame.

modes of transport can be shown in graphic detail in the event of, for example, incidents within a station because the desired dynamic or static images can be displayed on a sequential information communication display part by commands from a control part without having to change the display part.

Moreover, the same system can be used in the event of incidents in the vicinity of a station and transportation information provided thereby.

Furthermore, the appropriate instructions can be given to passengers because information can be exchanged with other stations or with train cars which are underway and individual passengers can make the decisions that are right for them without confusion.

In this case, although it is obvious that the same broadcast can be made on all information communication display screens, when necessary, information can be displayed only in stations within a specific block.

Therefore, this invention performs a wide variety of information provision and management functions in which a wide range of instructions can be provided to passengers or passersby, as well as station area information, advertisements about special events, and the like. It is therefore a

This information transmission display part J may also be formed on the sidewall 9 of the train car.

In this constitution, it is unnecessary to replace each and every poster as in the prior art. The content of the information can be instantly changed as desired even when the train car is in motion, and a wide range of information content can be selected.

In a third embodiment, [the invention] is formed on the rear wall of a newspaper stand 10 which is installed on a platform.

The rear wall of the newspaper stand 10 which is installed on a platform is an unused area which is currently used for the placement of a trash can for the like. A cathode ray tube or panel-type information transmission display part J is configured on this wall surface.

Furthermore, an interactive type information providing system is also possible by providing an operating console J1 or a touch panel-type information transmission display part because, given the location, there is adequate space.

Effect of the Invention

Given the present invention as constituted above, [passengers] can be guided or turnstiles closed, detailed explanations of the accident situation provided, or alternative

multipurpose, economical, and up-to-date system which supports the increasing centrality and importance of stations as terminals by constituting a combination of a variety of devices therein.

4. Brief Description of the Drawings

Figs. 1-3 show in embodiment of the information communication display part of the present invention. Fig. 4 is an integration drawing of the system of the present invention. Fig. 5 is a block diagram illustrating the configuration of the control part.

- A Passenger ticket automated vending machine operating part
- J Information communication display part
- C Control part
- H Central control part

Patent applicant: Rinjiro MINESAKI
 Patent applicant: Hisao USHIIHISA
 Representative: Masanori WADA, patent attorney

Fig. 1

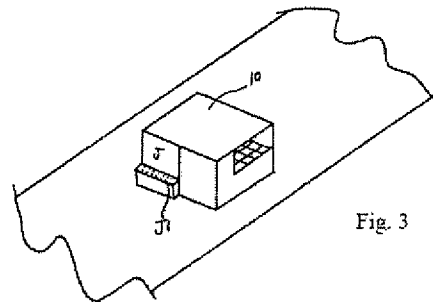
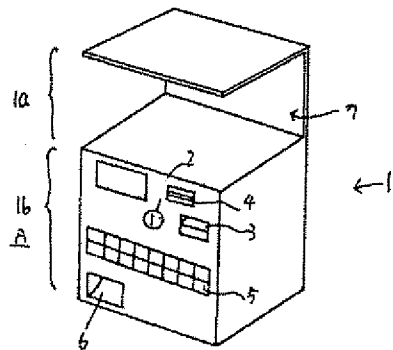

Fig. 3

Fig. 2

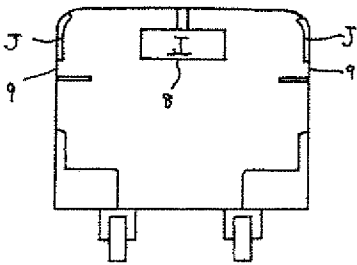

Fig. 4

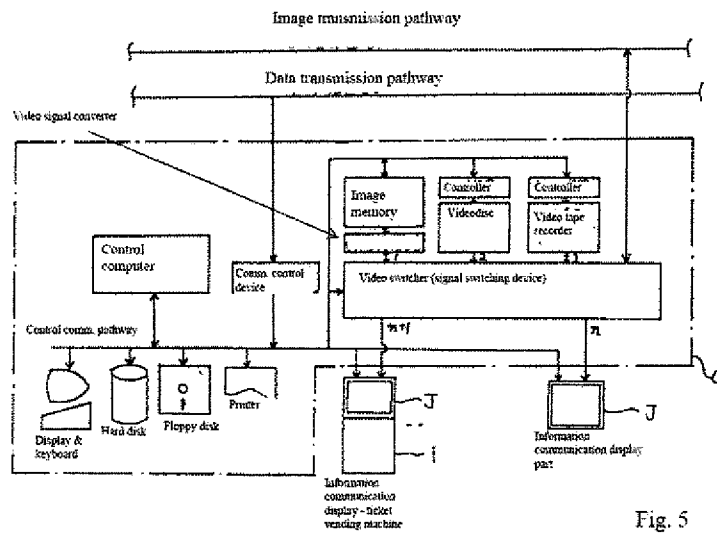
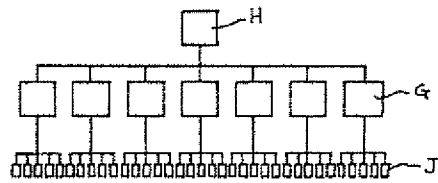

Fig. 5

(19) Japanese Patent Office (JP)

(11) Patent application
publication number:

(12) Official Gazette for Unexamined Patents (A)

H2-223985

(51) Int. Cl. ³	Identification	Internal File
GO9G 3/00	Nos.	Nos.
GO9F 9/00		
	363	Z
		6376-5C
		6422-5C

(43) Application publication
date: September 6, 1990

Request for Examination: Not filed Number of Claims: 1 (Total 8 Japanese pages)

(54) Title of the Invention System Providing Nonstandard Information to a Large Indefinite Number of People in a Transportation Vehicle

(21) Application No.	H1-42966
(22) Filing Date	February 27, 1989

(72) Inventor	Yoshikazu Amano	Hitachi Ltd., Yokohama Works, 292, Yoshida-cho, Totsuka-ku, Yokohama, Kanagawa Prefecture
(72) Inventor	Koichi Umezama	Hitachi Ltd., Design Laboratory, 1-280, Higashi-koigakubo, Kokubunji, Tokyo
(72) Inventor	Tadahiro Yamaguchi	Hitachi Ltd., Design Laboratory, 1-280, Higashi-koigakubo, Kokubunji, Tokyo
(72) Inventor	Sachihiro Kawakatsu	Hitachi Ltd., Design Laboratory, 1-280, Higashi-koigakubo, Kokubunji, Tokyo
(71) Applicant	Hitachi Ltd.	4-6, Kanda Suragadai, Chiyoda-ku, Tokyo
(74) Agent	Katsuo Ogawa, Patent Attorney and one other	

Continued on last page

Specifications

1. Title of the Invention
System Providing Nonstandard Information to a Large Indefinite Number of People in a Transportation Vehicle

2. Patent Claims

(1) A system providing nonstandard information to a large indefinite number of people in a transportation vehicle comprising a display device for providing nonstandard information capable of changing the display content at any time in the limited space of a transportation vehicle provided as the transportation means to a large indefinite number of people; a means for transmitting the provided information from inside the transportation vehicle to the display device; and a means for receiving the information transmitted from outside of the transportation vehicle and providing the information to said transmission means in the transportation vehicle.

3. Detailed Description of the Invention
(Field of Industrial Application)

The present invention relates to a system which takes the opportunity to effectively use the time on a transportation vehicle to provide various information to a large indefinite number of people who are using a limited space such as an airplane, train, and bus as a transportation means by

installing display devices for providing nonstandard information.

(Prior Art)

Conventionally, in a transportation device used by a large indefinite number of people, such as a train or a bus, usually, information such as advertisements and notifications in the vehicle hang down as printed material or are posted on the walls. These are normally displayed for a limited time period. In the case of advertisements, the provider of the transportation means obtains income from advertising contracts over a prescribed period.

A related known example is the "New Video Service System in Vehicles with Liquid Crystal Displays" reported on radio and in newspapers on February 14, 1989.

(Problems to Be Solved by the Invention)

When the prior art described above is viewed from the perspective of providing information, the provided information is displayed for a constant time period as described above because printed material is posted. When the posted information is changed, the printed material posted in the vehicle must be replaced each time. Usually, this posted information is displayed at a large number of places from several locations to several tens of locations in a single vehicle, but when used in several tens of connected cars as in a train, that

number reaches several hundred locations. Consequently, when the posts are changed periodically, the problems are the difficult management and no improvement in the utilization rate of the locations providing information.

In addition, when viewed from perspective of receiving information, because the information provided is the same for a constant time period, new information is viewed once and ignored thereafter. Even if new information is posted, because the posted information is viewed for the most part when in its presence for approximately several tens of minutes, the problem is that the amount of information is low considering the occupation at the posted location. Information provision means using light-emitting diodes exist, but are limited to providing standard information with fixed information such as the name of the station stop, the type of train, etc. There are examples of video and text information provided in the vehicles, but these are limited to providing the information set up in the vehicles, and information is not provided promptly.

An objective of the present invention is to provide a system which solves the problems described above.

(Means for Solving the Problems)

The problems described above are overcome by installing display devices for providing nonstandard information having

provided information; 4, a device for receiving transmissions of region-specific information and signals from the transportation vehicle; 5, a region-specific information controller which controls the transmission of region-specific information and manages the signals received from the transportation vehicle; and 6, an information signal transmission path between the region-specific information controller and the region-specific transmitter.

An example where the transportation vehicle is a bus is explained with reference to Figure 1. The region-specific information transmitter/receiver 4 is installed at each bus stop, collects the provided information transmitted from the region-specific information controller 5, and transmits the information provided through antenna 3 to the transportation vehicle 1. The transportation vehicle 1 receives the information provided through antenna 2, and provides the information to customers through the display information signal transmitter and the information signal display devices installed in the bus. A transportation vehicle 1a provides information stored in region-specific information transmitter 4b through antennas 3b, 2a to the interior of the bus. A transportation vehicle 1b provides information stored in region-specific information transmitter 4n through antennas 3n, 2b to the interior of the bus. The region-specific information controller 5 controls which information is sent to the region-specific information transmitter 4. Consequently, the transmitted information content from region-specific information

displayed content which can be changed at any time and devices for transmitting the information provided on the display devices from inside and outside of a transportation vehicle in a transportation vehicle, such as an airplane, a train, or a bus as the transportation means which has limited space to a large unspecified number of people.

(Operation)

The target provided information is transmitted from a transmitter, which has a function for setting and transmitting the nonstandard provided information placed in a location not used by the passengers in the transportation vehicle, for example, the cockpit in an airplane, the conductor's cab in a train, or the driver's seat on a bus; and a function for receiving and transmitting the information received from outside of the transportation vehicle, and can be displayed on a plurality of display devices set up at locations used by the passengers.

(Embodiments)

Embodiments of the present invention are described with reference to the following figures.

Figure 1 shows the entire system of the present invention. Reference number 1 is a transportation vehicle; 2, an antenna installed in the transportation vehicle; 3, an antenna primarily for transmitting the

transmitters 4a to 4n may differ from each other or be identical. In addition, the transmitted information can be changed for some plurality of regions.

This system is bidirectional. When the transportation vehicle 1 arrives at a stop, the provided information is received from the region-specific information transmitter/receiver described above, and signal notifying the arrival of transportation vehicle 1 at the stop is transmitted to antenna 3 from antenna 2. That signal is received by the region-specific information transmitter/receiver 4, passed through the transmission path 6, and transmitted to the region-specific information controller 5, and the navigation status of the transportation vehicle 1 can be determined. In addition, this status can be transmitted as information to the next stop to notify waiting customers.

In this drawing, the transmission paths 6 are indicated by wires to simplify the representation. Naturally, wireless transmission paths based on communication satellites can be used. In this case, the antennas for transmission and reception such as parabolic antennas can be installed in the region-specific information controller 5 and the region-specific information transmitter/receiver 4.

Figure 2 shows a display information signal transmitter and an information signal display device installed in the transportation vehicle. Reference number 7

is a display information signal transmitter and comprises a video information playback function 7b which primarily plays back video stored on a video disk or a videotape; a text and image information input function 7e which primarily reads out text and image information from a storage medium such as a magnetic disk or a memory card and inputs information depending on the associated input key; a text and image information control function 7d for controlling the enabling of the input information display; a video, text, and image information synthesis function 7c which synthesizes the video information played back by the video information playback function 7b and information from the text and image information control function 7d and selects either one; a region-specific information reception function 7f which primarily receives and stores the region-specific information from outside of the transportation vehicle; an information transmission function 7g which finally transmits the information provided to the customers through the information display devices; and an operation control function 7a for operating these functions. Reference numbers 2 and 3 are antennas; 4, a region-specific information transmission function primarily for transmitting region-specific information; 8, an information display device for displaying the provided information transmitted from the display information display device 7; and 9, transmission paths between these devices. Reference number 10 is

Normally, the provided information provides any one of the video, text, and image information stored on a video disk or a videotape or their combinations. However, when the region-specific information is transmitted through antenna 3 from the region-specific information transmission function 4, the information is received by antenna 2 and the transmitted data are stored by the region-specific information input function 7f, passed through the text and image information control function 7d, text and image information synthesis function 7c, and information transmission function 7g, and displayed on the information signal display device 8. The provided information not only supplements the video and text and image information provided beforehand to the transportation vehicle, but can provide urgent information. For example, a news crawl and information restricted to the region can be provided. This information can change the content of the provided information in units while the transportation vehicle follows its route if the region-specific information transmission function 4 is installed.

Figure 3 shows the form assuming the transportation vehicle is a train. In the example, cultural information 11 in segment 1, event information 12 in segment 2, and theme park information 13 in segment 3 are provided to the information signal display

device 8. In this example, information is provided over the entire surface of the information signal display device 8. The video or text and image information described above are synthesized and provided. A portion of that information can be used and provided.

Figures 4 to 7 show an example of the information signal display device 8 in the transportation vehicle installed in the train. (Effects of the Invention)

According to the present invention, the locations providing information in a transportation vehicle can be put to good use, and compared to when conventional printed material are posted, not only is the management time reduced, an effect is that the power of information provided to the customers is strengthened because promptness and newness are brought out.

4. Brief Description of the Drawings

Figure 1 shows an example of the entire system of the present invention. Figure 2 is a drawing for explaining an example of the device functions in the transportation vehicle. Figure 3 shows an example of the provision of region-specific information. Figures 4, 5, 6, and 7 show examples of the information signal display device installed in the transportation vehicle.

Descriptions of the Reference Numbers

- 1 transportation vehicle
- 2 antenna installed in the transportation vehicle
- 3 antenna installed in a region-specific information transmission function
- 4 region-specific information transmission function
- 5 region-specific information controller
- 6 transmission path
- 7 display information signal transmitter
- 8 information signal display device
- 9 transmission path
- 10 traveling status information input
- 11, 12, 13 examples of region-specific information provision
- 14 example of information provided on printed material

Agent: Katsuo Ogawa, Patent Attorney

Clean copies of the drawings (no changes to the content)

Figure 1

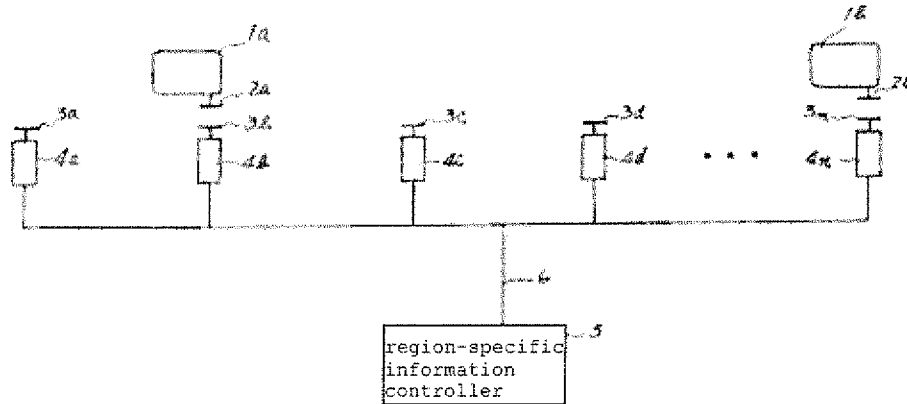

Figure 2

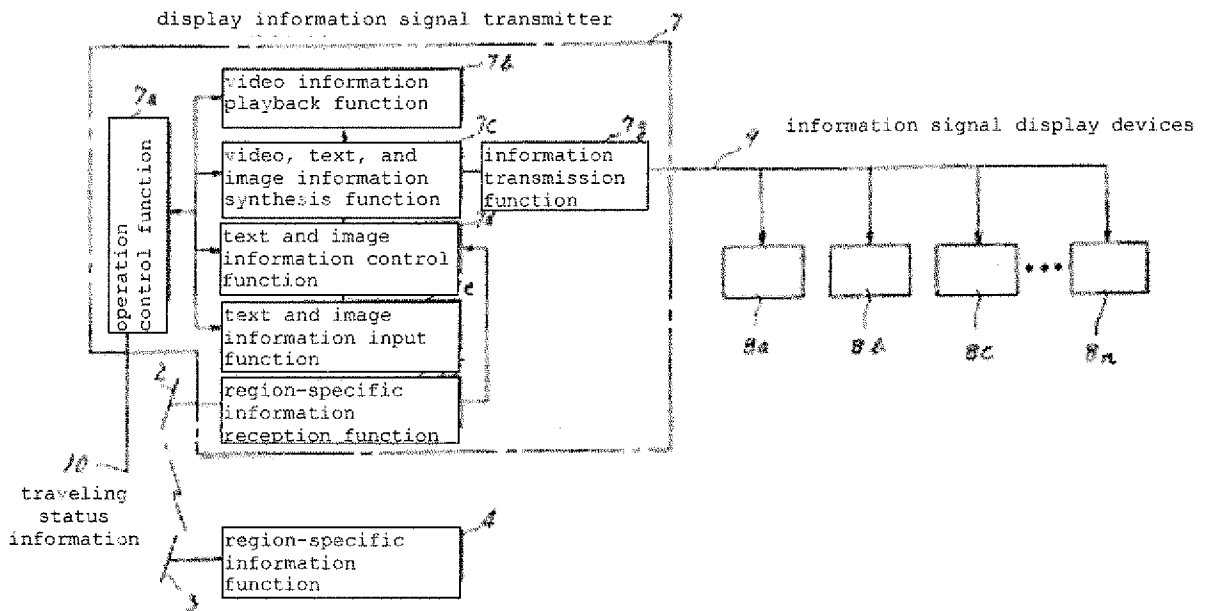

Figure 3

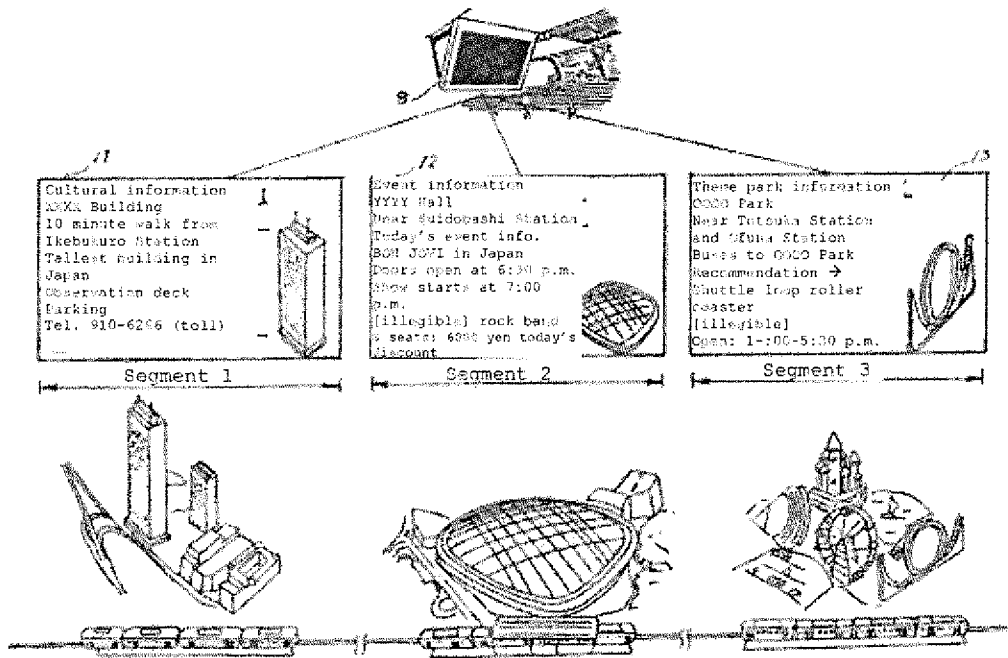

Figure 4

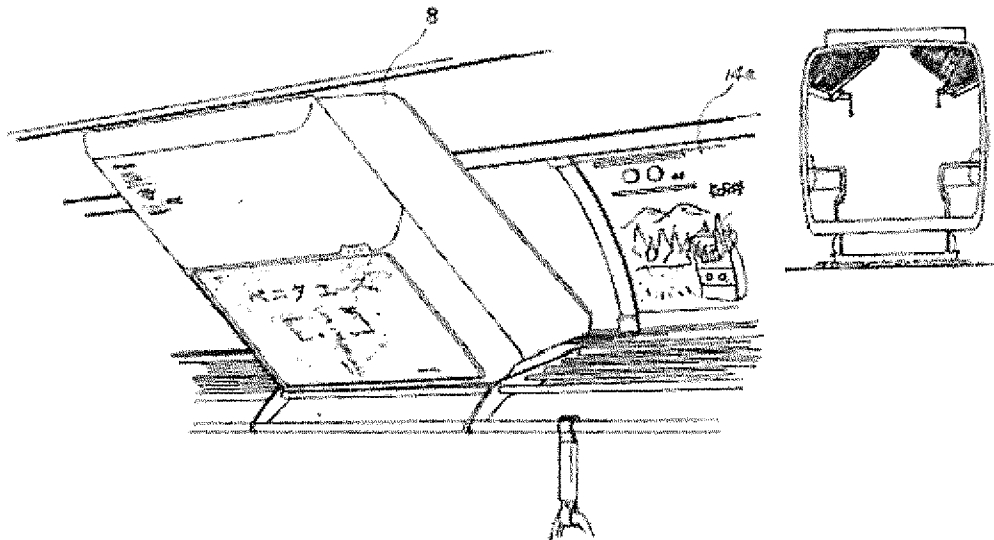

Figure 5

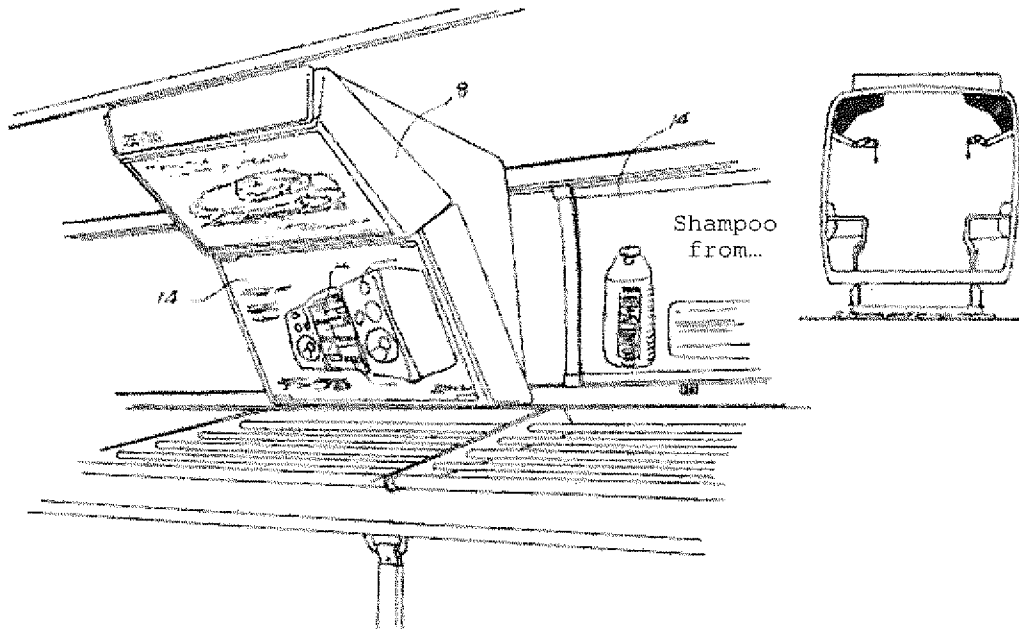

Figure 6

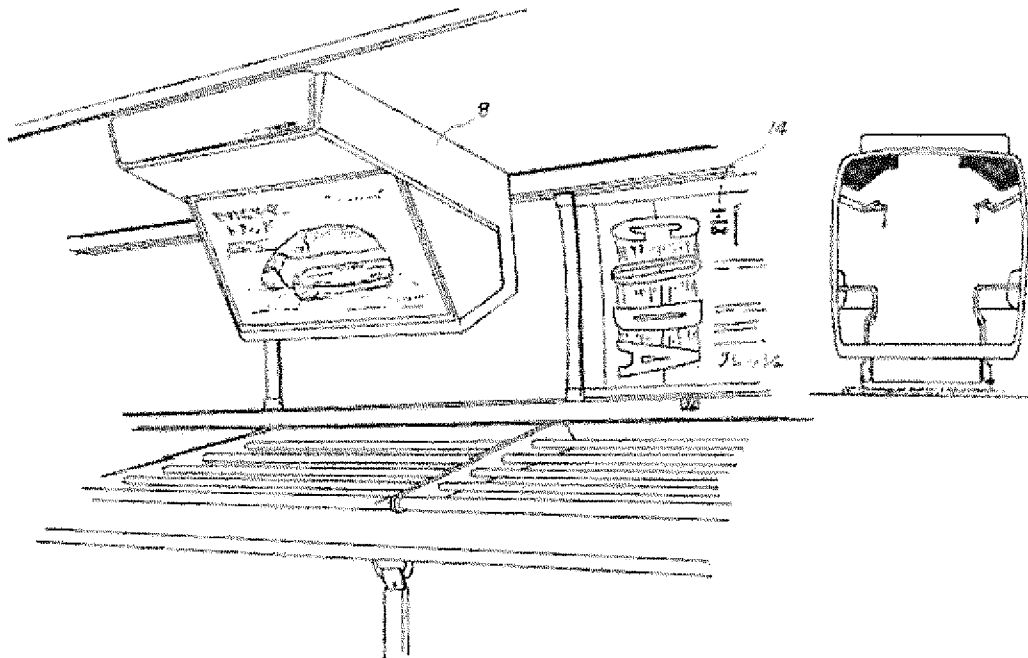
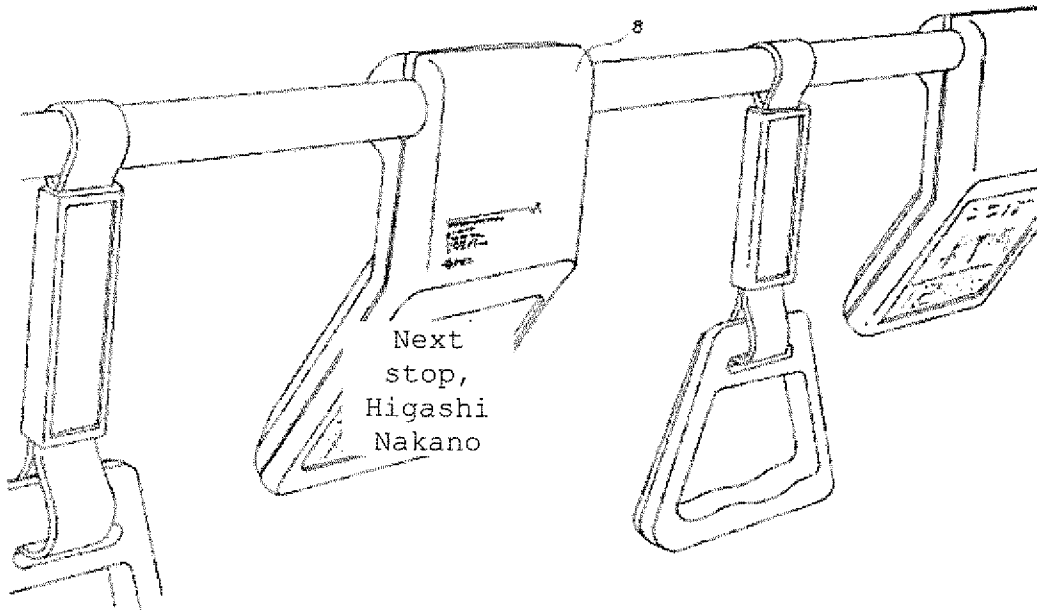

Figure 7



Continued from page 1

(72) Inventor Nobuo Fukuda Hitachi Ltd., Design Laboratory, 1-280,
Higashi-koigakubo, Kokubunji, Tokyo

Japanese Unexamined Patent Application Publication No. H2-223985 (8)

Procedural Amendment (Formality)

June 21, 1989

To: Commissioner of the Japan Patent Office

Case Indication

1989 Patent Application No. 42966

Title of the Invention: System Providing Nonstandard Information to a Large
Indefinite Number of People in a Transportation
Vehicle

Amending Party

Relationship to the Case: Patent applicant

Name: Hitachi Ltd. (510)

Applicant:

Address

Hitachi Ltd.

1-5-1, Marunouchi, Chiyoda-ku, Tokyo

Name

Katsuo Ogawa, Patent Attorney (6850) [stamp:]
[illegible]

Date of Amendment Order: May 30, 1989 (dispatch date)

Object of Amendment

All of the drawings

Amended Content

Clean copies on separate papers of all of the drawings
initially appended to the application
(Content not changed)

[stamp:] JPO, 6/21/1989, Second Application Dept.

End

Formal examination

	(19) Japan Patent Office (JP)	(11) Published Unexamined Patent
(12) Official Gazette for Unexamined Patent Applications (A)		Application No. H04-160991
(51) Int. Cl. ⁵	Identification No.	JPO File No
H04N 7/08	A	8838-5C
9/00	C	7033-5C
	Request for Examination: Not yet requested	
	Total Number of Claims: 1 (Total pages 9)	
(54) Title of the Invention:	Teletext Broadcast Receiving System for Mobile Body	
	(21) Application Number:	H02-288142
	(22) Filing Date:	October 25, 1990
(72) Inventor:	Yoshio Maekawa	c/o East Japan Railway Co., 6-5 Marunouchi 1 Chome, Chiyoda-ku, Tokyo
(72) Inventor:	Toru Kajita	c/o East Japan Railway Co., 6-5 Marunouchi 1 Chome, Chiyoda-ku, Tokyo
(72) Inventor:	Mare Tadama	c/o Sony Corp., 7-35 Kitashinagawa 6 Chome, Shinagawa-ku, Tokyo
(72) Inventor:	Fumihisa Sato	c/o Sony Corp., 7-35 Kitashinagawa 6 Chome, Shinagawa-ku, Tokyo
(71) Applicant:	East Japan Railway Co.	6-5 Marunouchi 1 Chome, Chiyoda-ku, Tokyo
(71) Applicant:	Sony Corp.	7-35 Kitashinagawa 6 Chome, Shinagawa-ku, Tokyo
(74) Agent:	Hidemori Matsue, Patent Attorney	

Continued on final page

Specification

Title of the Invention: Teletext Broadcast Receiving System for Mobile Body

Claim

A teletext broadcast receiving system for a mobile body comprising a tuner for receiving television broadcasts installed in a mobile body, a teletext broadcast decoder that extracts and demodulates teletext data from a television broadcast signal received by said tuner, a memory that stores a plurality of screen portions of the teletext data obtained by said teletext broadcast decoder and a display means that displays the teletext broadcast data stored in said memory

such that, when at least one screen portion of teletext broadcast data for a teletext broadcast channel that has been deemed necessary has been demodulated by said teletext broadcast decoder, this screen of teletext broadcast data obtained by demodulation is stored in the corresponding area of said memory and the stored data of said memory is updated.

Detailed Description of the Invention

[Field of Application in Industry]

The present invention relates to a teletext broadcast receiving system for a mobile body preferably used in installations in mobile bodies such as electric trains.

[Summary of the Invention]

The present invention is a teletext broadcast receiving system for a mobile body that is installed in a mobile body such as an electric train wherein, when at least one screen portion of teletext broadcast data for a teletext broadcast program that has been deemed necessary is demodulated by a teletext broadcast decoder, this screen of teletext broadcast data that has been obtained by demodulation is stored in a corresponding area of a memory, the stored data of the memory storing teletext broadcast data is updated, and even when all of the data for the teletext broadcast program has not been received, the teletext broadcast program may be displayed favorably.

[Prior Art]

In recent years, television receivers have been installed in mobile bodies such as electric trains, images reproduced by VTRs and the like received and services provided to passengers. In such cases, an antenna is attached to the roof of the electric train, television broadcast signals received from ground-based transmitting stations by this antenna and images received.

[Problems to be Solved by the Invention]

However, the ability to receive these television broadcast signals has been limited to times when locations with comparatively good radio wave states are traveled through. In other words, with mobile bodies traveling through areas with many obstacles such as the buildings in cities, there are few locations where good reception is possible without unnecessary interference for the broadcast signals from the transmitting stations. The state of reception is very poor when a normal television antenna is just installed on a mobile body, and the images are often such that they are not good enough for practical use. For example, in the case of the Yamanote electric train line that runs roughly through the center of Tokyo, the distance from the transmitting stations is very short, and under normal circumstances it is area with a strong electric field capable of good reception even with a simply structured antenna. However, there are very many obstacles such as buildings, and it is close to impossible to receive television signals with conventional technology without ghosting.

In addition, radio waves for teletext broadcasts are transmitted using some television broadcast signals, but since these signals for teletext broadcasts are converted into digital data for transmission, it is

impossible to receive the teletext broadcasts in moving bodies which are particularly sensitive to occurrences of ghosting.

It is an object of the present invention to make good reception of teletext broadcasts possible in moving bodies such as electric trains.

[Means to Solve the Problems]

As is shown, for example, in Fig. 1, the present invention comprises a tuner for receiving television broadcasts (43) installed in a mobile body (1), a teletext broadcast decoder (46) the demodulates teletext broadcast data extracted from a television broadcast signal received by this tuner (43), a memory (47) that stores a plurality of screen portions of the teletext broadcast data obtained by this teletext broadcast decoder (46) and display means (101), (102), (103) ... (124) that display that teletext broadcast data stored in this memory (47). When at least one screen portion of teletext broadcast data for a teletext broadcast program that is deemed to be necessary has been decoded by the teletext broadcast decoder (46), this teletext broadcast data that has been obtained by decoding is stored in a corresponding area of the memory (47), and the stored data in the memory (47) is updated.

[Work or Operation of the Invention]

Therefore, if the data for all screens for the teletext broadcast program initially deemed necessary is stored in the memory, the data for the teletext broadcast program may be updated sequentially even if only part of the data for a screen of the teletext broadcast program can be received while the mobile body is traveling or the like by updating only the data for this part that could be received to the latest data. All of the screen data for the teletext broadcast program deemed necessary is stored in the memory; therefore, display of all screens of the corresponding teletext broadcast program is possible at any given time.

[Embodiment]

In the following, an embodiment of the present invention will be described with reference to Fig. 1 through Fig. 4.

In this example, a television receiver is used in a receiving system that displays teletext broadcasts; therefore, the overall constitution of this receiving system will be described first.

In Fig. 1 and Fig. 2, (1) indicates a car body for an electric train, and doors (entrances and exits) (11), (12), (13) ... (16) and (17), (18), (19) ... (22) are provided in six locations on each side in the side surface of this car body (1). Television receivers (101), (102), (103) ... (124) are installed above the left and right door pocket parts for each of the doors (11) through (22) inside the car. As is shown in Fig. 2, for example, television receivers (117) and (118) are attached to the upper part of the door pocket part on the left and right of the door (19). In this instance, each of the television receivers (101), (102), (103) ... (124) is made low profile using liquid crystal panels or the like.

Furthermore, these various television receivers (101), (102), (103) ... (124) are for displaying teletext broadcasts, but to receive these teletext broadcasts, four antennas (30a), (30b), (30c), (30d) are attached to the periphery of ventilators (3) and (4) on the rooftop (2) of the car body (1). In this instance, each of the antennas (30a), (30b), (30c), (30d) has a dipole antenna

constitution comprising two conductive rods (31), (32) one of the ends of each being in proximity to each other and a reflector (33) disposed at a prescribed gap from these conductive rods (31), (32). The gap part between the two conductive rods (31), (32) is connected to a coaxial cable (35) (see Fig. 3) through a balloon (matching transformer), and this coaxial cable (35) is connected to a switching unit (41) inside an under-floor unit (40). The length of the two conductive rods (31), (32) is selected according to the frequency of the channel received, and the reflector (33) is longer than the length of the two conductive rods (31), (32) together.

Furthermore, the angles of attachment of the four antennas (30a), (30b), (30c), (30d) are offset 90° each in the horizontal direction. Antennas (30a), (30b) are attached to the front and back (direction parallel to the rails) of the ventilator (3), and antennas (30c), (30d) are attached to the left and right (direction perpendicular to the rails) of the ventilator (4) which is adjacent to the ventilator (3).

Describing the state of attachment of the antennas to the ventilators in detail here, this car body

Furthermore, one end of linking members (34) forming the antennas (30c) and (30d) is secured to the top part of this cover (24), and along with each of these linking members (34) securing a reflector (33) substantially in the middle part, the conductive rods (31), (32) are secured to the other end. Here, the two conductive rods (31) and (32) are provided with a prescribed gap and secured to the linking member (34). In addition, insulating material is used for the linking members (34). In addition, in this example, an angle material with an L-shaped cross-section is used for the conductive rods (31), (32) and reflectors (33) and is such that they may easily attached.

Here, a space H in the direction of height between the upper part of each ventilator and the lower edge of the reflector (33) is set to at least 15 mm, and width L in the horizontal direction between each ventilator and the reflector (33) is set to at least a width of 20 mm. Furthermore, the reflector height B is set to 70 mm or greater. In this instance, larger values for the height H and width L of the ventilator and the height B of the reflector (33) itself are preferable in terms of the antenna characteristics, but the size of equipment that can actually be installed on the rooftop (2) is determined by standards such as rolling stock gauge.

(1) has a plurality of ventilators (3), (4), (5) ... on the roof (2). These ventilators (3), (4), (5) ... are so-called forced ventilators that function as ventilation devices forcing air into the car from the outside while it is traveling, and legs (3a), (4a), (5a) at the four corners of each of the ventilators (3), (4), (5) ... are secured to the rooftop (2) by bolts (23). In this instance, each of the ventilators (3), (4), (5) ... is attached to the car body (1) in an insulated state.

Furthermore, two antennas (30a), (30b) are attached using the bolts (23) that secure the legs (3a) at the four corners of the ventilator (3). In addition, two antennas (30c), (30d) are attached using the bolts (23) that secure the legs (4a) at the four corners of the ventilator (4) which is adjacent to the ventilator (3).

Showing an enlargement of the state of attachment of these antennas (30c), (30d) to the ventilator (4) in Fig. 3 and Fig. 4, a U-shaped cover (24) is attached around the ventilator (4) by the bolts (23). In this instance, the cover (24) is such that it does not block the air passage part (4b) of the ventilator (4).

Very large antennas cannot be attached, and values somewhat larger than the values above are the limit for these values.

With the attachment of the four antennas (30a), (30b), (30c), (30d), each of the antennas (30a), (30b), (30c), (30d) only receives the radio waves oriented toward the conductive rods (31), (32). The radio waves oriented toward the conductive rods (31), (32) from the opposite side (ventilator side) are shielded by the reflector (33), and the generation of standing waves by reflected radio waves can be controlled. Therefore, radio waves that come from all directions in substantially 360° may be received by the four antennas (30a), (30b), (30c), (30d) that are installed in positions that differ by 90° each.

Furthermore, the four antennas (30a), (30b), (30c), (30d) constituted in this manner are connected to the switching unit (41) inside the under-floor unit (40) that is hung beneath the floor of the car body (1) by the coaxial cables (35). The equipment for receiving teletext broadcasts is housed in this under-floor unit (40), and the switching unit (41) selectively outputs receive signals supplied by any of the antennas under the control of a discriminator circuit (44) which will be discussed hereinafter. Furthermore, this switching unit

(41) supplies the received signal that is output to a ghost reduction tuner (43) via a booster (42), and this ghost reduction tuner (43) receives a television broadcast signal for a prescribed channel that is set in advance. In this instance, the ghost reduction tuner (43) uses a GCR signal that has been inserted into the vertical blanking interval, and ghost reduction is carried out on the received broadcast signal; therefore, a ghost suppression filter, GCR signal extraction circuit, comparator circuit, control circuit and the like are provided in both the channel tuning section and intermediate frequency amplifier/demodulator section. A GCR signal in which distortion due to diffuse reflection of radio waves and the like and a reference signal are compared, and reflected wave signals are suppressed.

Here, in this example, the prescribed channel television broadcast signal obtained by this ghost reduction tuner (43) is supplied to the discriminator circuit (44), and the level of the synchronizing signal included in the television broadcast signal received by this discriminator circuit (44) is determined. The selection of the antenna line by the switching unit (41) is set to the synchronous signal with the best level, and a so-called diversity antenna is formed.

Describing the constitution of this memory (47) here, the data storage part of this memory (47) is divided into a plurality of areas, and the areas are used as shown in Fig. 5. In other words, it is such that four teletext broadcast channels A, B, C, D may be stored, and there are areas a1 through a10, b1 through b10, c1 through c10 and d1 through d10 that can store 10 screen portions from page 1 to page 10 for each program. In this instance, areas a1 through a10, b1 through b10, c1 through c10 and d1 through d10 are such that the stored data for each area may be updated independently if they have data for a prescribed teletext broadcast program stored in them for the time being when operation of the car body (1) is started. When only the data for part of a page (screen) of one teletext broadcast program can be received, only the storage area for this page that could be received is rewritten. Therefore, there are instances where the stored data for each page making up the various teletext broadcast programs A, B, C, D is not stored at the same time. Moreover, when each of the teletext broadcast programs A, B, C, D is made up of 10 or less pages, the area for the page for which data could not be obtained is left empty.

In this instance, a timer circuit (45) is connected to this discriminator circuit (44), and the level determination described above is carried out in a prescribed interval with control by the timer circuit (45).

Furthermore, the television broadcast signal obtained by the ghost reduction tuner (43) is supplied to the teletext broadcast decoder (46), and a teletext broadcast signal of text, graphics and the like multiplied by the vertical blanking time for the broadcast signal is obtained by this teletext broadcast decoder (46). In this instance, a plurality of teletext broadcast programs are sent by a single channel television broadcast signal, and when at least one screen portion of data for a prescribed teletext broadcast channel set in advance has been obtained, this data is recorded in the memory (47) connected to the teletext broadcast decoder (46). In other words, the teletext broadcast decoder (46) has a circuit that determines whether or not each teletext broadcast screen that is received and obtained is complete. When it is determined that data for a complete screen for even one screen has been obtained by this circuit, and when this data is a teletext broadcast channel that is deemed necessary, it is stored in the memory (47).

Furthermore, the data for the prescribed teletext broadcast program stored in the memory (47) in this manner is sequentially read out to the teletext broadcast decoder (46) and formed into a video signal that displays the text, graphics and the like as images. This video signal is output from the under-floor unit (40) via a coaxial cable. When, in this instance, at least one screen portion of any program of the four stored teletext broadcast programs A, B, C, D is rewritten, this rewritten program is read sequentially from the first page to the final page and is displayed.

Moreover, the output video signal from the under-floor unit (40) is a baseband video signal (in other words a video signal that is not RF modulated). In this example, in addition, a power supply circuit (48) is provided in the under-floor unit (40), and a low voltage direct current power supply is output from this power supply circuit (48).

Furthermore, the coaxial cable that outputs the video signal from the under-floor unit (40) is connected to a three-way distribution unit (61) in the car body (1) to provide the output video signal. In addition, the power supply output from the power supply circuit (48)

is also supplied to the three-way distribution unit (61). This three-way distribution unit (61) is such that the baseband video signal is divided in three.

Furthermore, of the first, second and third distribution outputs from this three-way distribution unit (61), the first distribution output is supplied to a first two-way distribution unit (71), the second distribution output supplied to a connection terminal (62) provided on a connection surface on a first end (one end) side of the car body (1) and the third distribution output supplied to a connection terminal (63) provided on a connection surface on a second end (other end) side of the car body (1). In addition, the power supply supplied to the three-way distribution unit (61) is also supplied to the first two-way distribution unit (71).

This first two-way distribution unit (71) is such that it divides the baseband video signal that is supplied in two.

Furthermore, the first distribution output distributed by the first two-way distribution unit (71) is supplied to a second two-way distribution unit (72) connected to a subsequent stage, and the second distribution output is supplied to a 13th two-way distribution unit (83) that is connected to a subsequent stage. In this instance, the power supply supplied from the three-way distribution unit (61) side is supplied to

(113) attached inside the car, and the second distribution output is supplied to a 14th two-way distribution unit (84) in the subsequent stage.

Hereafter, the baseband video signal supplied by two-way distribution units (84), (85), (86) ... (93) connected to subsequent stages is divided in two in the same manner, and the first distribution output is supplied to the corresponding television receivers (114), (115), (116) ... (124) attached inside the car. The second distribution output is supplied to two-way distribution units (85), (86), (87) ... (93) connected to the subsequent stage. However, the second distribution output of the 23rd two-way distribution unit (93) connected at the end is supplied to a television receiver (124).

In this instance, the power supply supplied from the two-way distribution unit in the previous stage is supplied to television receivers connected to the various two-way distribution units and the two-way distribution unit in the subsequent stage.

Moreover, when the connection terminals (62) and (63) provided on the connection surface are linked before and after to another car that is not provided with a tuner and the like, it is connected to a video signal input terminal in this linked car (not shown in the drawings). The video signals for the teletext broadcasts and the like may be supplied to preceding and following

the second and 13th two-way distribution units (72) and (83).

This second two-way distribution unit (72) divides in two in the same manner as the first two-way distribution unit (71), and the first distribution output is supplied to a television receiver (102) attached inside the car. The second distribution output is connected to a third two-way distribution unit (73).

Hereafter, the baseband video signal supplied by two-way distribution units (73), (74), (75) ... (82) connected to subsequent stages is divided in two in the same manner, and the first distribution output is supplied to the corresponding television receivers (103), (104), (105) ... (111) attached inside the car. The second distribution output is supplied to the two-way distribution units (74), (75), (76) ... (82) connected to the subsequent stage. However, the second distribution output of the 12th two-way distribution unit (82) connected at the end is supplied to a television receiver (112).

In this instance, the power supply supplied from the two-way distribution unit in the previous stage is supplied to television receivers connected to the various two-way distribution units and the two-way distribution unit in the subsequent stage.

In addition, the first distribution output of the 13th two-way distribution unit (83) connected to the second distribution output side of the first two-way distribution unit (71) is supplied to a television receiver

cars. In this instance, the power supply necessary for the television receivers in the preceding and following cars is supplied by a power supply circuit in each of the cars.

Next, the operation when teletext broadcast images are displayed on the television receivers (101), (102), (103) ... (124) connected in this manner will be described.

First, the teletext broadcast is received, and the data for the teletext broadcast program deemed necessary is stored in the memory (47) connected to the teletext broadcast decoder (46). If, in this instance, the state of reception for the television broadcast signal is good, the operation of storing to the memory (47) is completed in a short time, but service is actually provided when the car (1) is traveling. Therefore, when the reception state is temporarily good and when at least one screen portion of data for a teletext broadcast programs deemed necessary can be obtained by the teletext broadcast decoder (46), this data for the screen that is obtained is stored in the memory (47), and the data for the same page that was stored previously is updated newly to that received.

In other words, as is shown in the flow chart in Fig. 6, the screen for the teletext broadcast program

received by the teletext broadcast decoder (46) is assembled, and a determination is made as to whether the screen that is assembled is a complete screen (in other words, whether the screen that is assembled has parts missing). Furthermore, when the screen that is assembled is complete, the data for this screen is written to the corresponding area of the memory (47), and the data in this area is rewritten. Furthermore, when this rewriting occurs, the stored data in the memory (47) for the teletext broadcast program that is rewritten is read so that is displayed sequentially starting with the first page, and they output video signal is created by the teletext broadcast decoder (46). In addition, when the assembled screen is determined to be an incomplete screen, the assembled screen data is discarded, and at this time the received data is not stored.

When a teletext broadcast program is received, the direction of the transmitting station as seen from the car (1) varies because of the travel, but the constitution is a diversity antenna that determines whether it is possible to have good reception from any of the four antennas (30a), (30b), (30c), (30d) in directions differing by 90°. Connection to the tuner (43) side is made with each of these antennas (30a), (30b), (30c), (30d) in order by the

teletext broadcast program displayed at prescribed intervals is read and the video signal that displays the teletext broadcast is created. This video signal is transmitted to the television receivers (101) through (124) via the various distribution units (61), (71) through (93), and the teletext broadcast program is displayed on the television receivers (101) through (124) disposed in this car. In this instance, the four teletext broadcast programs stored in the memory (47) are displayed sequentially in a cycle of several minutes to several tens of minutes. However, when new teletext broadcast program data can be received as described above, this program that can be received is displayed starting with the first page.

Moreover, in the embodiment described above, only teletext broadcast receiving equipment was installed, but VTR and other image reproduction equipment may be provided, and reproduced images may be displayed instead of the teletext broadcast program. In addition, this was such that when data for a teletext broadcast program can be received, this teletext broadcast program was displayed, but the four teletext broadcast programs may be displayed sequentially in each prescribed time period regardless of the state of the reception of data.

In addition, in the embodiment described above, the receiving system was installed in an

switching unit (41), and the state of reception is sequentially determined by a determination circuit (44) in the ghost reduction tuner (43). The connection is made to the antenna obtaining the best broadcast signal.

Moreover, since having a temporarily good state of reception and obtaining a screen for a teletext broadcast program deemed to be necessary by the teletext broadcast decoder (46) is limited to extremely good states of reception, most are when the train is stopped at stations and the like. In other words, for example, in the case of an electric train traveling as a local train in the city center, the train is stopped several tens of seconds to one minute at a station every 2 to 3 minutes of travel. The possibility of reception of a teletext broadcast program during this train stoppage being possible is high, and reception of teletext broadcasts is possible with the comparatively high frequency. In this instance, the time necessary for a one screen portion of the one teletext broadcast program to be transmitted is often normally under one second and at the longest several seconds; therefore, it is sufficiently possible to receive a teletext broadcast program using the constitution described above.

Furthermore, if teletext data can be imported into the memory (47) connected to the teletext broadcast decoder (46) in this manner, the data for the

electric train, but it may be used in another mobile body (automobile, ship or the like).

Furthermore, the present invention is also not limited to the embodiment described above and various other constitutions naturally possible.

[Effects of the Invention]

According to the present invention, even when only the data for some screens for this teletext broadcast program can be received during the traveling or the like of a mobile body, just the part of this data that could be received is updated to the most recent data, and the data for the teletext broadcast program is updated sequentially to the most recent data. Teletext broadcast programs using comparatively the most recent data may always be displayed even if the state of reception in the mobile body deteriorates because of travel or the like.

Brief Description of the Drawings

Fig. 1 is a block diagram showing an embodiment of the present invention. Fig. 2 is a partial cutaway perspective view showing the state of the system of an embodiment installed in a car body. Fig. 3 is a perspective view showing the important parts of an embodiment. Fig. 4 is a side view showing the important parts of an embodiment. Fig. 5 is an explanatory diagram showing the state of use of the memory of an embodiment. Fig. 6 is a flow chart to

accompany a description of an embodiment. (1) is a car body. (3), (4) ... (8) a ventilator, (30a), (30b), (30c), (30d) antennas, (40) under-floor unit. (41) switching unit, (43) ghost reduction tuner, (46) teletext broadcast decoder, (47) memory, (48) power supply circuit, (61) three-way distribution unit. (62), (63) connection terminals, (71), (72) ... (93) two-way distribution units and (101), (102) ... (124) television receivers.

	Program A	Program B	Program C	Program D
Page 1	a1	b1	c1	d1
Page 2	a2	b2	c2	d2
Page 3	a3	b3	c3	d3
Page 10	a10	b10	c10	d10

Example of memory areas
Fig. 5

Agent: Hidemori Matsue

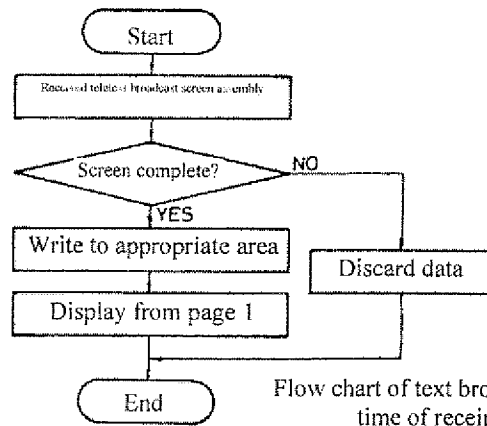

Flow chart of text broadcasting time of receipt
Fig. 6

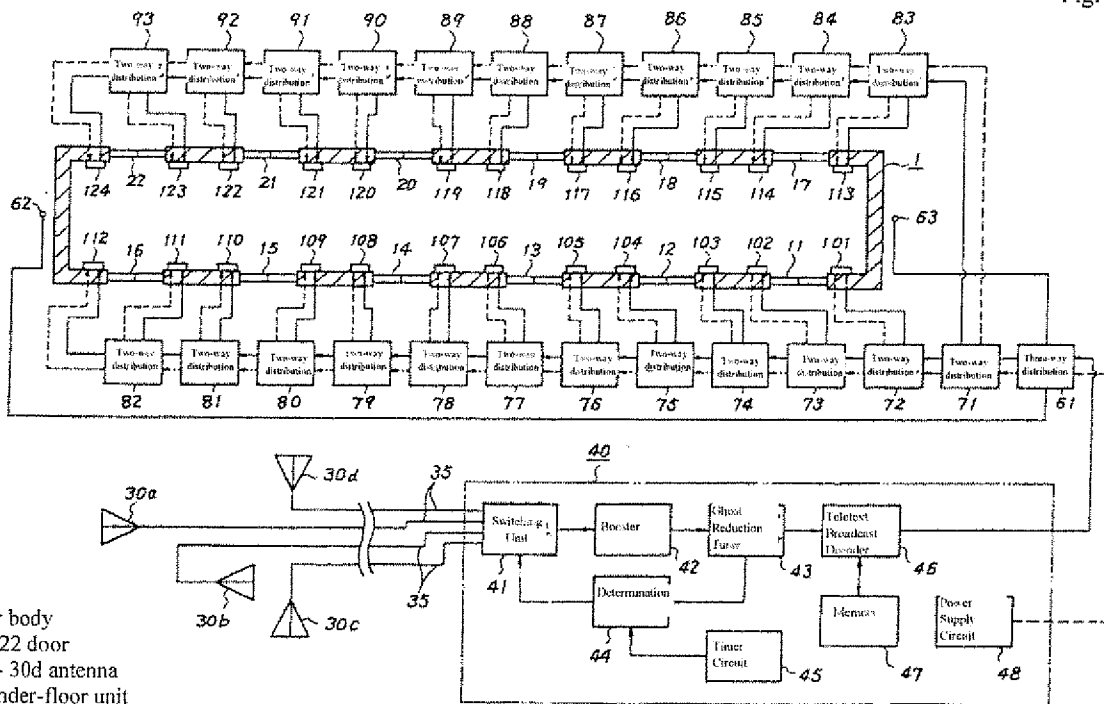

1 car body
11 - 22 door
30a - 30d antenna
40 under-floor unit
101 - 124 television receiver

Overall constitution

Fig. 1

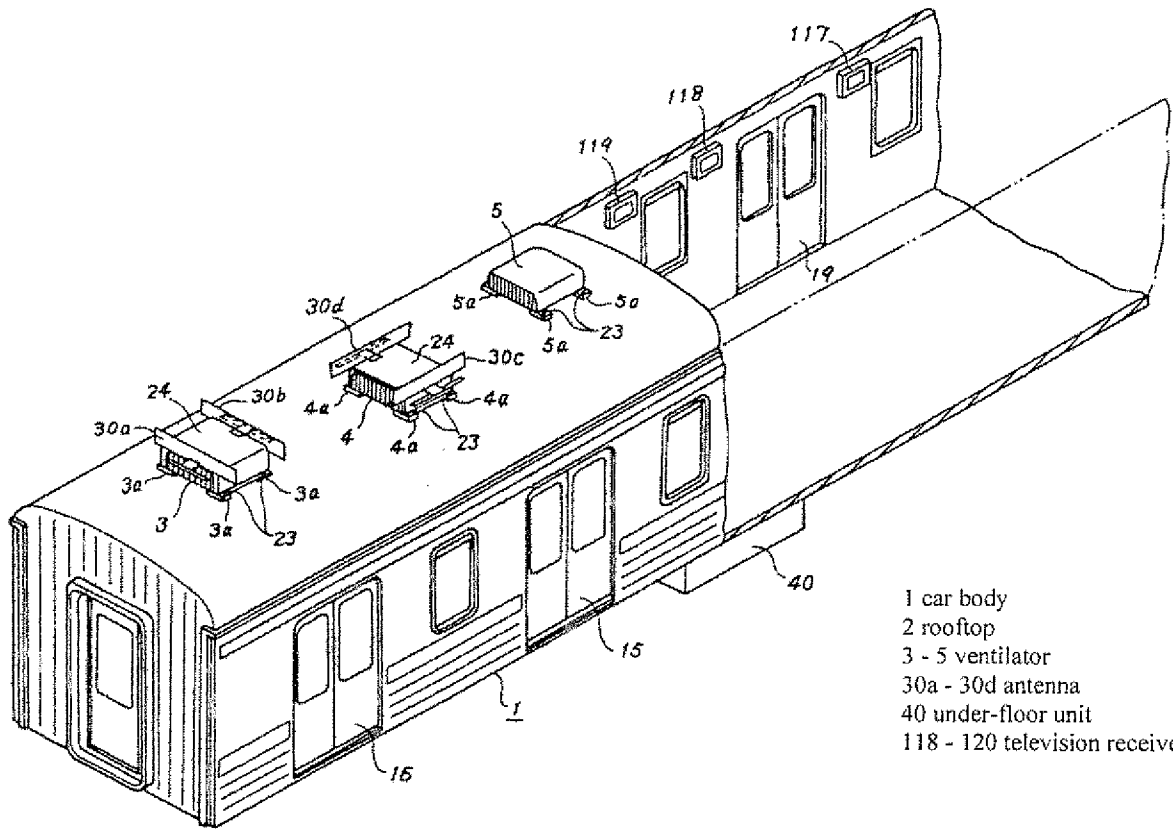

- 1 car body
- 2 rooftop
- 3 - 5 ventilator
- 30a - 30d antenna
- 40 under-floor unit
- 118 - 120 television receiver

State of attachment to car body
Fig. 2

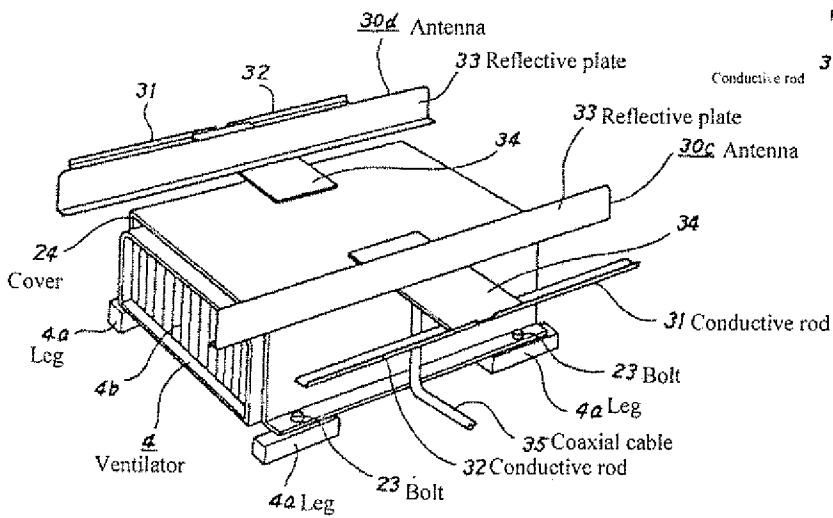

Enlargement of area around antenna
Fig. 3

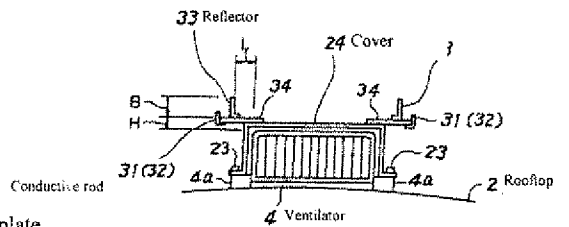

Drawing showing state of attachment of antenna
Fig. 4

Continued from first page

(72) Inventor: Ken'ichi Kato

(72) Inventor: Takehiko Arai

(72) Inventor: Torao Aozuka

c/o Sony Corp., 7-35 Kitashinagawa 6 Chome, Shinagawa-ku, Tokyo

c/o Sony Corp., 7-35 Kitashinagawa 6 Chome, Shinagawa-ku, Tokyo

c/o Sony Corp., 7-35 Kitashinagawa 6 Chome, Shinagawa-ku, Tokyo

(19) Japan Patent Office
(JP)

(12) **Official Gazette for Unexamined
Patents (A)**

(11) Patent Application Number

S61-285490

(43) Application Publication date: December 16, 1986

(51) Int. Cl. ⁴	Identification Numbers	Internal File Numbers
(51) Int. Cl. ⁴		C-7436-5C
G 09 G 3/00		7817-3D
B 61 K 13/00		6731-5C
G 09 F 9/00		

Request for examination: Not filed Number of inventions: 1 (Total 5 Japanese pages)

(54) Title of the Invention: In-Vehicle Information Guide System
(21) Application number S60-128601
(22) Filing Date June 13, 1985

(72) Inventor Hiroshi SHINAGAWA Fujitsu Co., Ltd., 1015, Kamikodanaka, Nakahara-ku, Kawasaki

(72) Inventor Mitsumasa YAMAMOTO Fujitsu Co., Ltd., 1015, Kamikodanaka, Nakahara-ku, Kawasaki

(71) Applicant Fujitsu Co., Ltd. 1015, Kamikodanaka, Nakahara-ku, Kawasaki

(74) Agent Koshiro MATSUOKA,
Patent Attorney

Specifications

1. Title of the Invention

In-Vehicle Information Guide System

2. Patent Claims

(1) An in-company [sic] information guide system for broadcasting the displays of guide information about the next and/or later station stops in a traveling train comprising an information processor (A) which is provided in the train and compiles image information data as the information for broadcast on the train;

a transmitter (B) for distributing the created image information data as image information to each display device; and

a display device (C) installed in each car.

(2) The in-vehicle information guide system described in claim 1, wherein the image information data created as described above includes guide information about at least the name of the next station stop; expected arrival time; special express trains, express trains, departure times, destinations, and boarding platforms related to the first train or bus departing after the time of the specified transfer time added to the expected arrival time in the schedules for each route related to the transportation

facilities of the current train company or other companies having connections at the next station stop.

(3) The in-vehicle information guide system described in claim 1 or 2, wherein said display device is installed in the upper part of a wall on the side of the aisle in the train, or above the window at each passenger seat.

3. Detailed Description of the Invention

Overview

In the past, the information guide in a train was by voice using in-company [sic] broadcast facilities based on the conductor rounds. However, since the voice is not preserved, the information cannot be provided no matter how many times it is repeated to passengers who were asleep or missed the announcement or passengers who forgot. Therefore, broadcasts using images are conducted to fix the deficiency of voice broadcasts. Alternately, both are used together.

Field of Industrial Application

The present invention relates to an information guide service system based on image broadcasts to passengers

riding on a traveling train, more particularly, to a system providing information services which do not disappear and can be viewed at any time within a prescribed time on a display device.

Problems of the Prior Art

Conventional information announcements were voice broadcasts to the passengers through speakers provided in each car bell [sic] by wire from a broadcast facility provided in the conductor's cab. However, since voice is fleeting and disappears, the weakness is that this information cannot be provided to passengers who need information and forgot or missed the information for whatever reason. The problem was the repetition of the broadcast to fix this weakness annoyed the other passengers.

Solution Means

The intent of the present invention is to provide information content in a visual guide as described above as image information broadcast (displayed) in each car and to preserve the information for a prescribed time to

enable reading by passengers needing information at any time.

The structure of the hardware for realizing the above intent provides an information processor which a crew member manages, operates, and selects and compiles image information data, and a transmitter which distributes and broadcasts the image information data created (selected and compiled) on the processor to each display device as the image information at locations which can be managed by the crew member in the conductor cab on the train; and provides a solution by displaying and broadcasting the guide information needed by the passengers disembarking at the next station stop on the display devices provided on each side of the car.

If some information will be provided, the following operating conditions apply. The image information data created as the display content described above is displayed before stopping at the next station. The data is information related to transfers for connections, such as the station name, expected arrival time (desirably, updated if late), platform number which are required by passengers disembarking at the next station. The information is continuously displayed on the display devices installed at locations where the information can be selected from a diagram and is easily seen. In addition, the information is successively updated and provided until the next stop.

Embodiments

Figure 1 is a drawing for explaining one embodiment and also serves as a drawing of the principle of the present invention.

Figures 2, 3, and 4 are supplemental drawings of Figure 1. Figure 2 shows the operation for creating the image display data conducted on the information processor as an operation flow.

Figure 3 describes the input and compilation in a function block diagram.

Figure 4 shows the installation locations of the display devices.

The interior of part A delineated by the dot-dash lines in Figure 1 shows the information processor. The interior of part B shows the transmitter. The interior of part C shows the display device on each side of the car. Data buses 6 connect an information processor A which has an operating unit 2 including a monitor unit connected to a central processing unit 1 (referred to as a CPU); a main storage 3 (referred to as MS) which becomes the working area for data compilation where the data are compiled with CPU 1; and data files 4, 5 storing trip planning data of the train containing at least the planned departure time, names of the station stops, each station, departure platform number

between each station from the starting station of the boarded train to the final station during the current trip, trip planning (train schedule) data of related connecting trains at each station stop including information about the departure time from each station, destination, and departure platform (terminal) of connecting trains departing from the stations where the boarded train stops (the term connecting trains includes ordinary trains, express trains, and special express trains which have a given route; ordinary trains, express trains, and special express trains which are traveling on different routes and headed in different directions; as well as trains, boats, and vehicles of transportation facilities such as buses having terminals at the station stop which connect at later stops), and source data containing at least various information needed for compilation which includes the required extra time information believed to be required to move between platforms and between platform terminals to make connections for each station stop of the boarded train.

After the operating unit 2 is operated and the train departs, Figure 3 shows one example of the set-up data indicated by the double line frames. Specifically, data for displaying the station name related to the station stop settings from the data files 4, 5 when the name of the next station stop (may be encoded) is set;

data for displaying the expected arrival time; data related to the departure times and platforms of connecting trains; and if needed, data related to the required extra time for connecting are retrieved and set for each setting in the MS 3 from the files 4, 5 by using the setting of the station name in the setting unit 31 of the name of the next station stop as the key. If there is a difference between the current train schedule and his expectations (running late), the operator compiles by revising and setting the arrival time, required extra time, and display item in each setting unit.

First, in the compilation, a comparator 36 compares the time of the required extra time for connecting in each direction set in the extra time setting unit 35 added to the arrival time setting unit 32 at the next station stop of the boarded train to the departure time data group of the connecting trains departing in each direction from the train schedule memory unit 34 which reads in only the needed part stored in file 5; selects the trains available for connection in each direction; and passes the trains to the train selection unit 37. Next, in order to compile the connection information data, the train selection unit 37 repeatedly compares the departure times, selects the train at the closest time for each train class of the trains available for connection which were selected by the

Next, preferably, the display devices 21 to 2n are arranged on the walls flanking the aisles of each train or above the windows of the passenger seats at approximately the eye level of an average adult walking by.

In a variation of the present invention, when a train is late, if the change in the expected arrival time can be changed on the train, data compiled beforehand and supplied on a medium such as a disk cartridge or a floppy disk greatly lessens the operations performed by the crew member on the train. In addition, although the scale will become large, the compilation is conducted at a central command center which manages the train movements and can be provided on-line to each train. Nearly the same effect is obtained as a service received by the passengers, but the time the crew member needs to directly perform the operations becomes smaller, which is an advantage.

Effects

The present invention as described above has the following effects. Guide information having a depth of information can be provided at the time required by a passenger needing an information guide on the train in a form which does not

comparator 36, and stores the information in the specified format location of the format and compilation unit 38 only for the needed directions.

Then, the name of the station stop, arrival time, and arrival platform related to the next station stop combined with data indicating the departure time, platform, destination, direction of the available connecting train in each direction and the data read from file 4 of associated data such as the train name, express or ordinary type, vehicle type such as train or bus are combined, formatted, and compiled to complete the compilation.

These operations, if needed, set and revise each monitor on the operating unit 2, and are executed primarily between the CPU 1 and the MS 3.

However, the image information data which have been compiled are transferred to the transmitter B which converts the data into image information for display on the display devices in each car and transmits the information. After conversion, the image information is broadcast from each of the display devices 21 to 2n as images.

the speed of the traveling train, and a more comprehensive service is available from the perspective of the operations.

4. Brief Description of the Drawings

Figure 1 is drawing for explaining an embodiment which also illustrates the principle of the present invention and describes the system structure.

Figures 2, 3, and 4 are supplementary drawings of Figure 1 which explain the operation flow of the embodiment as a flow, explain the function blocks, and show the display locations, respectively.

In the drawing, A indicates the information processor; B, the transmitter; and C, the display device. The assigned numbers indicate the detailed parts. Reference number 1 indicates the CPU; 2, the operating unit; 3, the main storage (MS); 4, 5, the data files; and 6, the paths. In addition, 11 indicates the setting unit of the compiled display data; 12, the image data conversion unit; 13, the transmitter; and 14, the display system controller.

disappear. Not only is there an improvement in the quality of the service which does not annoy passengers who do not need information compared to the operation based only on voice broadcasts, but an ability to revise as needed to match

Furthermore, 21, 22, ..., 2n indicate the display devices in each car.

In addition, 31 indicates the setting unit of the name of the next station stop; 32, the arrival time setting unit; 33, the display item setting unit; 34, the schedule storage unit for temporarily storing a part of the schedule; 35, extra time setting unit; 36, the comparator; 37, the selector; and 38, the format and compilation unit.

Agent: Koshiro Matsuoka, Patent Attorney
 [stamp:] Koshiro Matsuoka, Patent Attorney

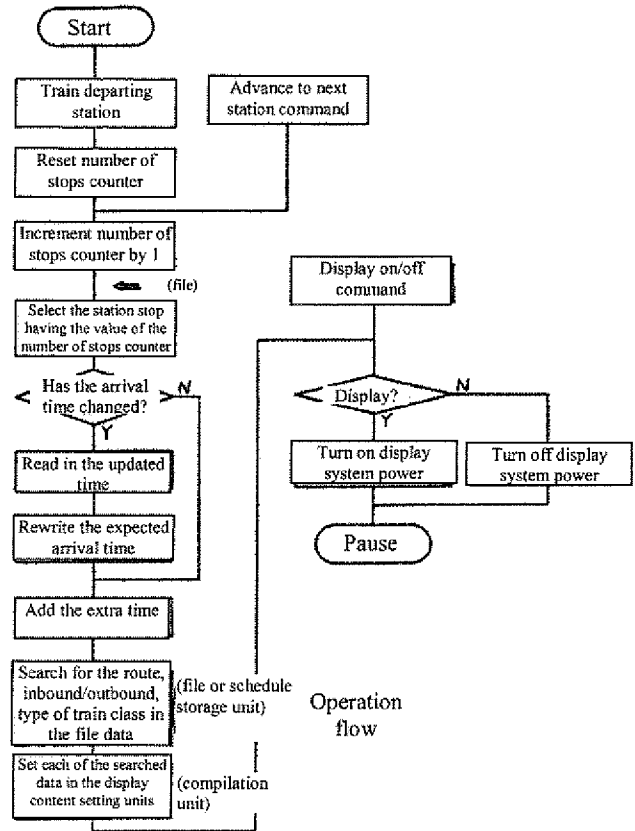

Figure 2

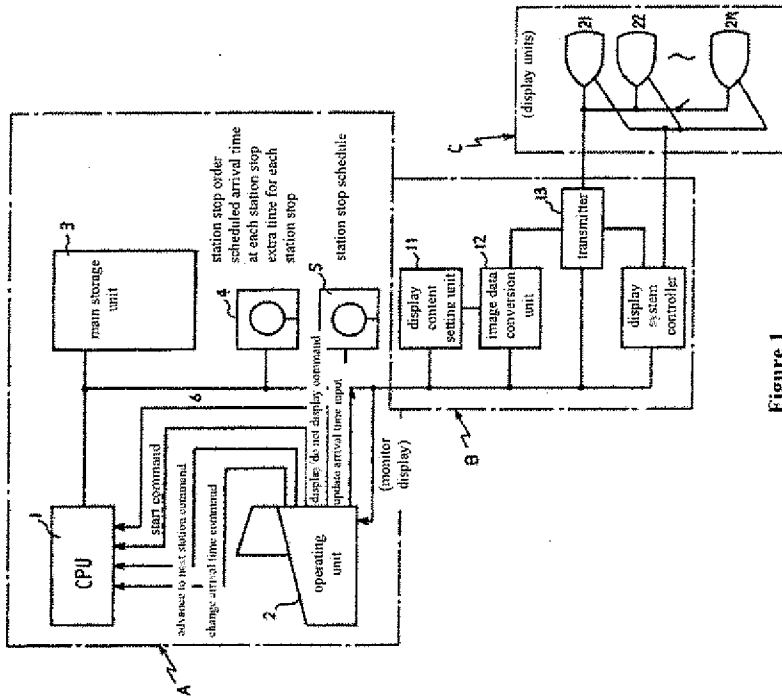
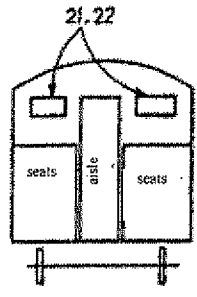
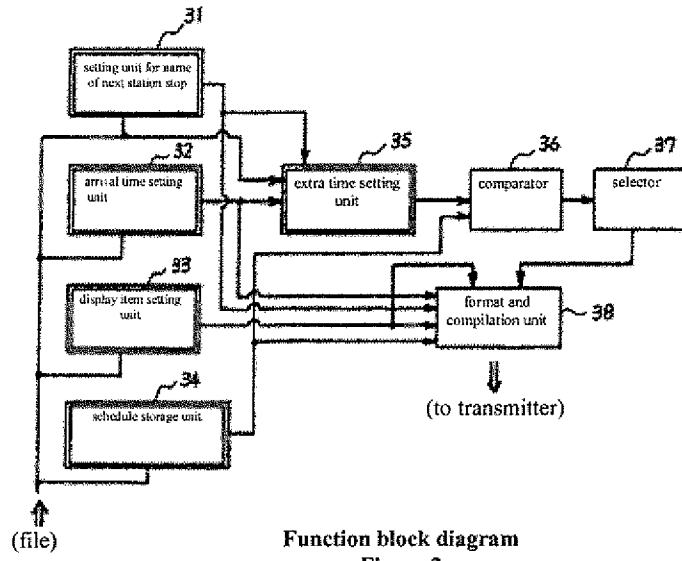

Figure 1





UNITED STATES PATENT AND TRADEMARK OFFICE

UNITED STATES DEPARTMENT OF COMMERCE
 United States Patent and Trademark Office
 Address: COMMISSIONER FOR PATENTS
 P.O. Box 1450
 Alexandria, Virginia 22313-1450
 www.uspto.gov



Bib Data Sheet

CONFIRMATION NO. 3736

SERIAL NUMBER 90/011,861	FILING OR 371(c) DATE 08/16/2011 RULE	CLASS 348	GROUP ART UNIT 3992	ATTORNEY DOCKET NO. BLAIR.001A
------------------------------------	---	---------------------	-------------------------------	--

APPLICANTS
 6700602, Residence Not Provided;
 SCOTT BLAIR, TORONTO, CANADA;
 PETER J. GUTIERREZ III, SAN DIEGO, CA;

**** CONTINUING DATA *******
 This application is a REX of 09/423,284 02/22/2000 PAT 6,700,602
 which is a 371 of PCT/CA98/00439 05/06/1998
 which claims benefit of 60/045,811 05/07/1997

**** FOREIGN APPLICATIONS *******

Foreign Priority claimed <input type="checkbox"/> yes <input type="checkbox"/> no	STATE OR COUNTRY	SHEETS DRAWING	TOTAL CLAIMS 7	INDEPENDENT CLAIMS 1
35 USC 119 (a-d) conditions <input type="checkbox"/> yes <input type="checkbox"/> no <input type="checkbox"/> Met after met Allowance				
Verified and Acknowledged	Examiner's Signature	Initials		

ADDRESS
 27299

TITLE
 SUBWAY TV MEDIA SYSTEM

FILING FEE RECEIVED 2520	FEES: Authority has been given in Paper No. _____ to charge/credit DEPOSIT ACCOUNT No. _____ for following:	<input type="checkbox"/> All Fees <input type="checkbox"/> 1.16 Fees (Filing) <input type="checkbox"/> 1.17 Fees (Processing Ext. of time) <input type="checkbox"/> 1.18 Fees (Issue) <input type="checkbox"/> Other _____ <input type="checkbox"/> Credit
------------------------------------	---	---

Litigation Search Report CRU 3999

Reexam Control No. 90/011,861

TO:
Location: CRU
Art Unit: 3992
Date: August 18, 2011

U.S. Patent Number: 6,700,602

From: Patricia Martin
Location: CRU 3999
MDW-7C55
Phone: (571) 272-7705

Search Notes

- 1) I performed a Key Cite Search in Westlaw, which retrieves all history on the patent including any litigation.
- 2) I performed a search in Lexis in the Federal Courts and Administrative Materials databases for any cases found.
- 3) I performed a search in Lexis in the IP Journal and Periodicals database for any articles on the patent.
- 4) I performed a search in Lexis in the news databases for any articles about the patent or any articles about litigation on this patent.
- 5) I performed a search on the patent in Lexis Court Link for any open dockets or closed cases.

No Litigation was found

Date of Printing: Aug 18, 2011

KEYCITE**C US PAT 6700602 SUBWAY TV MEDIA SYSTEM, (Mar 02, 2004)****History****Direct History**

=> 1 **SUBWAY TV MEDIA SYSTEM**, US PAT 6700602, 2004 WL 380060 (U.S. PTO Utility Mar 02, 2004) (NO. 09/423284)

Patent Family

2 **SUBWAY TV MEDIA SYSTEM E.G. FOR PUBLIC SERVICE MESSAGE DISPLAY - HAS SEVERAL TV MONITORS MOUNTED AT INTERVALS ALONG CARS AT JUNCTION OF SIDEWALL AND CEILING WITH CENTRAL VIDEO SIGNAL SOURCE CONNECTED TO VIDEO MONITORS AN**, Derwent World Patents Legal 1998-610758

Prior Art (Coverage Begins 1976)

- C** 3 **AIRCRAFT PASSENGER ENTERTAINMENT SYSTEM**, US PAT 4352124 Assignee: Bell & Howell Company, (U.S. PTO Utility 1982)
- C** 4 **AIRCRAFT PASSENGER TELEVISION SYSTEM**, US PAT 4647980 Assignee: Aviation Entertainment Corporation, (U.S. PTO Utility 1987)
- C** 5 **AUTOMATED MERCHANDISING SYSTEM**, US PAT 4073368 (U.S. PTO Utility 1978)
- C** 6 **AUTOMATIC ADVERTISING STATION ANNOUNCING SYSTEM AND METHOD**, US PAT 1894684 (U.S. PTO Utility 1933)
- C** 7 **BILLBOARD DEVICE**, US PAT 5229910 Assignee: Abisare Co., Ltd., (U.S. PTO Utility 1993)
- C** 8 **DEVICE FOR INTERFACING A CD-ROM PLAYER TO AN ENTERTAINMENT OR INFORMATION NETWORK AND A NETWORK INCLUDING SUCH DEVICE**, US PAT 5666291 Assignee: Sony Corporation, (U.S. PTO Utility 1997)
- C** 9 **DISPLAY APPARATUS FOR VEHICLE**, US PAT 5059957 Assignee: Nissan Motor Company, Limited, (U.S. PTO Utility 1991)
- C** 10 **DISPLAY DEVICE**, US PAT 5463827 Assignee: Hanover Displays Limited, (U.S. PTO Utility 1995)
- C** 11 **OVERHEAD SUPPORT SYSTEM FOR TV MONITORS**, US PAT 5009384 Assignee: Inter-Link Communications Inc., (U.S. PTO Utility 1991)
- C** 12 **PROJECTION STATION**, US PAT 3457006 Assignee: Bell ?? Howell Company, (U.S. PTO Utility 1969)
- C** 13 **REAR SCREEN VIDEO PROJECTION SYSTEM FOR AIRCRAFT PASSENGER ENTERTAINMENT**, US PAT 5123728 Assignee: Sony Trans Com, Inc., (U.S. PTO Utility 1992)

© 2011 Thomson Reuters. All rights reserved.

- C** 14 SYSTEM AND METHOD FOR PROCESSING PASSENGER SERVICE SYSTEM INFORMATION, US PAT 5854591 Assignee: Sony Trans Com, Inc., (U.S. PTO Utility 1998)
- C** 15 SYSTEM AND METHOD FOR SECURING A REMOVABLE SEAT ELECTRONICS UNIT WITHOUT DETACHMENT OF THE COMMUNICATION CABLE, US PAT 6038426 Assignee: Sony Corporation, (U.S. PTO Utility 2000)
- C** 16 TAXICAB ADVERTISING DEVICE, US PAT 3182550 (U.S. PTO Utility 1965)
- C** 17 TIMED ADVERTISING IN ELEVATORS AND OTHER SHUTTLES, US PAT 5606154 Assignee: Otis Elevator Company, (U.S. PTO Utility 1997)
- C** 18 VIDEO GAME APPARATUS INTEGRAL WITH AIRPLANE PASSENGER SEAT TRAY, US PAT 4630821 Assignee: Aero-Vision Systems, Inc., (U.S. PTO Utility 1986)

© 2011 Thomson Reuters. All rights reserved.

My Lexis™	Search	Get a Document	Shepard's®	More	History	Alerts
All	Legal	News & Business	Public Records	Patent Law	Find A Source	Add/Edit Subtabs

Legal > / ... / > Utility, Design and Plant Patents

Search View Tutorial | Help

Select Search Type and Enter Search Terms

Terms & Connectors	6700602 or 6,700,602	Suggest terms for my search
Natural Language		
Easy Search™		Check spelling
Semantic Search What's this?		

Search

Restrict by Document Segment

Select a document segment, enter search terms for the segment, then click Add.

Select a Segment **Add ^**

Note: Segment availability differs between sources. Segments may not be applied consistently across sources.

Restrict by Date

No Date Restrictions From To Date formats...

<p>Search Connectors</p> <p>and and w/p in same paragraph</p> <p>or or w/seg in same segment</p> <p>w/N within N words w/s in same sentence</p> <p>pre/N precedes by N words and not and not</p> <p>More Connectors & Commands...</p>	<p>How Do I...?</p> <p>Combine sources?</p> <p>Restrict by date?</p> <p>Restrict by document segment?</p> <p>Use wildcards as placeholders for one or more characters in a search term?</p> <p>View Tutorials</p>
--	--

In

About LexisNexis | Privacy Policy | Terms & Conditions | Contact Us
Copyright © 2011 LexisNexis, a division of Reed Elsevier Inc. All rights reserved.

My Lexis™	Search	Get a Document	Shepard's®	More	History	Alerts
------------------	---------------	-----------------------	-------------------	-------------	----------------	---------------

FOCUS™ Terms 6700602 or 6,700,602

Search Within Original Results (1 - 5)

Using Semantic Concepts

What's this?  Advanced...

[View Tutorial](#)

Source: **Legal > / . . . / > Utility, Design and Plant Patents** 

Terms: **6700602 or 6,700,602** (Suggest Terms for My Search)

Select for FOCUS™ or Delivery

1. 7724130, May 25, 2010, Systems and methods for distributing emergency messages, Norstrom, Pauline, Warrington, United Kingdom of Great Britain and Northern Ireland(GB), United Kingdom of Great Britain and Northern Ireland(GB); Newton, Michael, Manchester, United Kingdom of Great Britain and Northern Ireland(GB), United Kingdom of Great Britain and Northern Ireland(GB); 656822, May 15, 2007, ASSIGNMENT OF ASSIGNORS INTEREST (SEE DOCUMENT FOR DETAILS)., AD GROUP, UNIT 1200, DARESBURY BUSINESS PARK, WARRINGTON, UNITED KINGDOM(), WA44H5, reel-frame:019293/0889, AD Group, Warrington, United Kingdom of Great Britain and Northern Ireland(GB), Foreign company or corporation

CORE TERMS: message, receiver, emergency, station, detection, network, train, video, recipient, audio, computer-readable, messaging, epicenter, tag, occurrence, telephone, embedded, entity, evacuation, passenger, template, software, updated, storage, route, disk, functionality, catastrophic, customized, instruct

... 6698021, February 24, 2004, Amini et al., United States of America (US) **6700602**, March 2, 2004, Blair, United States of America (US) 6765991, July 20, ...

2. 7272356, September 18, 2007, Information delivery system, Hamada, Junichi, Tokyo, Japan(JP), Japan(JP); Maruyama, Kiyoyasu, Tokyo, Japan(JP), Japan(JP); Ohashi, Tomonori, Tokyo, Japan (JP), Japan(JP); Yoshimoto, Kyosuke, Tokyo, Japan(JP), Japan(JP); Emoto, Norishige, Tokyo, Japan(JP), Japan(JP); Sigeeda, Tetsuya, Tokyo, Japan(JP), Japan(JP); Masubuchi, Yoichi, Tokyo, Japan(JP), Japan(JP); Murakami, Takanori, Tokyo, Japan(JP), Japan(JP); 381706, March 27, 2003, ASSIGNMENT OF ASSIGNORS INTEREST (SEE DOCUMENT FOR DETAILS)., MITSUBISHI DENKI KABUSHIKI KAISHA, 2-3, MARUNOUCHI 2-CHOME, CHIYODA-KU, TOKYO, JAPAN(), 100-8310, reel-frame:014206/0426, Mitsubishi Denki Kabushiki Kaisha, Tokyo, Japan(JP), Foreign company or corporation

CORE TERMS: input, distribution system, inputted, transmission, controller, display, video, user, control signal, information storage, telephone, decoder, modulator, displayed, monitor, audio, audio signal, telephone bell, speaker, ring, processing, outputs signal, transmission line, transmitted, demodulator, reproduced, abnormal, outputting, train, video signal

... States of America (US) 6597764, July 22, 2003, Haze, United States of America (US) **6700602**, March 2, 2004, Blair, United States of America (US) 20020164148, November 7, ...

3. 6970168, November 29, 2005, On-board display system, Emoto, Norishige, Tokyo, Japan(JP); Maruyama, Kiyoyasu, Tokyo, Japan(JP); Ohashi, Tomonori, Tokyo, Japan(JP); Yoshimoto, Kyosuke, Tokyo, Japan(JP); Sigeeda, Tetsuya, Tokyo, Japan(JP); Masubuchi, Yoichi, Tokyo, Japan (JP); Murakami, Takanori, Tokyo, Japan(JP); 220054, August 27, 2002, ASSIGNMENT OF ASSIGNORS INTEREST (SEE DOCUMENT FOR DETAILS)., MITSUBISHI DENKI KABUSHIKI KAISHA 2-3, MARUNOUCHI 2-CHOME, CHIYODA-KUTOKYO, (1)100-8310, reel-frame:013385/0281, Mitsubishi Denki Kabushiki Kaisha, Tokyo, Japan(JP), Foreign company or corporation

CORE TERMS: car, display, train, transmission, path, termination, detecting, channel, denote, switch, intermediate, separated, railroad train, fault, outputted, synthesizing, detect, breaks down, demodulating, distributed, distribute, outputting, switchably, passenger, switching, schematic, train-borne, demodulate, detected, extracts

... United States (US), 725#119 6591314, July, 2003, Colbath, United States (US), 710#36 **6700602**, March, 2004, Blair, United States (US), 348#61 06-350535, December, 1994, ...

4. 6700602, March 2, 2004, Subway TV media system, Blair, Scott, 32 Marlow Avenue, Toronto, Ontario, M4J 3T9, Canada(CA); 423284,

CORE TERMS: monitor, subway cars, video, display, car, passenger, television, advertising, subway, video signal, player, video monitors, screen, enclosure, message, mass transit, intervals, recorder, duration, ceiling, digital, panel, transit systems, subway system, computer-based, entertainment, mounting, suitably, minute, windows

6700602

5. 20040227812 (Note: This is a Patent Application only.), November 18, 2004, Subway TV media system, Blair, Scott, Toronto, Canada(CA); 787822,

CORE TERMS: monitor, subway cars, video, display, car, passenger, television, advertising, subway, video signal, player, video monitors, screen, enclosure, message, mass transit, intervals, recorder, duration, ceiling, digital, panel, transit systems, subway system, computer-based, entertainment, mounting, suitably, minute, windows

Division of Ser. No. 09423284, February 22, 2000, GRANTED PATENT **6700602** 371 Of International Ser. No. PCT/CA98/00439, May 6, 1998 ...

Source: **Legal > / . . . / > Utility, Design and Plant Patents** 

Terms: **6700602 or 6,700,602** (Suggest Terms for My Search)

View: Cite

Date/Time: Thursday, August 18, 2011 - 9:07 AM EDT

In

About LexisNexis | Privacy Policy | Terms & Conditions | Contact Us
Copyright © 2011 LexisNexis, a division of Reed Elsevier Inc. All rights reserved.

My Lexis™	Search	Get a Document	Shepard's®	More	History	Alerts
All	Legal	News & Business	Public Records	Patent Law	Find A Source	Add/Edit Subtabs

Legal > Area of Law - By Topic > Patent Law > Find Cases > Patent Cases, Administrative Decisions and Regulatory Materials ⓘ

Search View Tutorial | Help

Broaden this search with additional sources

Patent Cases, Administrative Decisions and Regulatory Materials ⓘ (Source you selected)

Chisum on Patents ⓘ

Patent Law Digest ⓘ

Patent Case Management Judicial Guide ⓘ

Intellectual Property Counseling and Litigation ⓘ

Court of Appeals for the Federal Circuit Practice & Procedure ⓘ

[View all sources](#)

Select Search Type and Enter Search Terms

Terms & Connectors	6700602 or 6,700,602	<input type="button" value="Suggest terms for my search"/>	<input type="button" value="Search"/>
<input type="button" value="Natural Language"/>		<input type="button" value="Check spelling"/>	
<input type="button" value="Easy Search™"/>			

Restrict by Document Segment

Select a document segment, enter search terms for the segment, then click Add.

Select a Segment

Note: Segment availability differs between sources. Segments may not be applied consistently across sources.

Restrict by Date

No Date Restrictions ⓘ From To Date formats...

<p>Search Connectors</p> <table> <tr> <td>and</td> <td>and</td> <td>w/p</td> <td>in same paragraph</td> </tr> <tr> <td>or</td> <td>or</td> <td>w/seg</td> <td>in same segment</td> </tr> <tr> <td>w/N</td> <td>within N words</td> <td>w/s</td> <td>in same sentence</td> </tr> <tr> <td>pre/N</td> <td>precedes by N words</td> <td>and not</td> <td>and not</td> </tr> </table> <p>More Connectors & Commands...</p>	and	and	w/p	in same paragraph	or	or	w/seg	in same segment	w/N	within N words	w/s	in same sentence	pre/N	precedes by N words	and not	and not	<p>How Do I...?</p> <p>Combine sources?</p> <p>Restrict by date?</p> <p>Restrict by document segment?</p> <p>Use wildcards as placeholders for one or more characters in a search term?</p> <p>View Tutorials</p>
and	and	w/p	in same paragraph														
or	or	w/seg	in same segment														
w/N	within N words	w/s	in same sentence														
pre/N	precedes by N words	and not	and not														

In

About LexisNexis | Privacy Policy | Terms & Conditions | Contact Us
Copyright © 2011 LexisNexis, a division of Reed Elsevier Inc. All rights reserved.

No Documents Found

No documents were found for your search terms
"6700602 or 6,700,602"

Click "Save this search as an Alert" to schedule your search to run in the future.

- OR -

Click "Edit Search" to return to the search form and modify your search.

Suggestions:

- Check for spelling errors.
- Remove some search terms.
- Use more common search terms, such as those listed in "Suggested Words and Concepts."
- Use a less restrictive date range.

| [Save this Search as an Alert](#) || [Edit Search](#) |

In

[About LexisNexis](#) | [Privacy Policy](#) | [Terms & Conditions](#) | [Contact Us](#)
Copyright © 2011 LexisNexis, a division of Reed Elsevier Inc. All rights reserved.

My Lexis™	Search	Get a Document	Shepard's®	More	History	Alerts
All	Legal	News & Business	Public Records	Patent Law	Find A Source	Add/Edit Subtabs

Legal > Area of Law - By Topic > Patent Law > Search News > Patent, Trademark & Copyright Periodicals, Combined

Search View Tutorial | Help

Select Search Type and Enter Search Terms

Terms & Connectors	6700602 or 6,700,602	<input type="checkbox"/> Suggest terms for my search	<input type="button" value="Search"/>
<input type="checkbox"/> Natural Language		<input type="checkbox"/> Check spelling	
<input type="checkbox"/> Easy Search™			

Restrict by Document Segment

Select a document segment, enter search terms for the segment, then click Add.

Select a Segment

Note: Segment availability differs between sources. Segments may not be applied consistently across sources.

Restrict by Date

No Date Restrictions From To Date formats...

<p>Search Connectors</p> <p>and and w/p in same paragraph</p> <p>or or w/seg in same segment</p> <p>w/N within N words w/s in same sentence</p> <p>pre/N precedes by N words and not and not</p> <p>More Connectors & Commands...</p>	<p>How Do I...?</p> <p>Combine sources?</p> <p>Restrict by date?</p> <p>Restrict by document segment?</p> <p>Use wildcards as placeholders for one or more characters in a search term?</p> <p>View Tutorials</p>
---	--

In

About LexisNexis | Privacy Policy | Terms & Conditions | Contact Us
Copyright © 2011 LexisNexis, a division of Reed Elsevier Inc. All rights reserved.

<p>No Documents Found</p> <p>No documents were found for your search terms "6700602 or 6,700,602"</p> <p>Click "Save this search as an Alert" to schedule your search to run in the future.</p> <p>- OR -</p> <p>Click "Edit Search" to return to the search form and modify your search.</p> <p>Suggestions:</p> <ul style="list-style-type: none">● Check for spelling errors.● Remove some search terms.● Use more common search terms, such as those listed in "Suggested Words and Concepts."● Use a less restrictive date range. <p> Save this Search as an Alert Edit Search </p>
--

In

[About LexisNexis](#) | [Privacy Policy](#) | [Terms & Conditions](#) | [Contact Us](#)
Copyright © 2011 LexisNexis, a division of Reed Elsevier Inc. All rights reserved.

My Lexis™	Search	Get a Document	Shepard's®	More	History	Alerts
All	Legal	News & Business	Public Records	Patent Law	Find A Source	Add/Edit Subtabs

News & Business > Combined Sources > News, All (English, Full Text)

Search View Tutorial | Help

Select Search Type and Enter Search Terms

Terms & Connectors	6700602 or 6,700,602	Suggest terms for my search <input type="button" value="Search"/> Check spelling
Natural Language		
Easy Search™		

Restrict by Document Segment

Select a document segment, enter search terms for the segment, then click Add.

Select a Segment

Note: Segment availability differs between sources. Segments may not be applied consistently across sources.

Restrict by Date

No Date Restrictions From To Date formats...

<p>Search Connectors</p> <table style="width: 100%;"> <tr> <td>and</td> <td>and</td> <td>w/p</td> <td>in same paragraph</td> </tr> <tr> <td>or</td> <td>or</td> <td>w/seg</td> <td>in same segment</td> </tr> <tr> <td>w/N</td> <td>within N words</td> <td>w/s</td> <td>in same sentence</td> </tr> <tr> <td>pre/N</td> <td>precedes by N words</td> <td>and not</td> <td>and not</td> </tr> </table> <p>More Connectors & Commands...</p>	and	and	w/p	in same paragraph	or	or	w/seg	in same segment	w/N	within N words	w/s	in same sentence	pre/N	precedes by N words	and not	and not	<p>How Do I...?</p> <p>Combine sources? Restrict by date? Restrict by document segment? Use wildcards as placeholders for one or more characters in a search term?</p> <p>View Tutorials</p>
and	and	w/p	in same paragraph														
or	or	w/seg	in same segment														
w/N	within N words	w/s	in same sentence														
pre/N	precedes by N words	and not	and not														

In

About LexisNexis | Privacy Policy | Terms & Conditions | Contact Us
Copyright © 2011 LexisNexis, a division of Reed Elsevier Inc. All rights reserved.

My Lexis™	Search	Get a Document	Shepard's®	More	History	Alerts
------------------	---------------	-----------------------	-------------------	-------------	----------------	---------------

FOCUS™ Terms Search Within [Advanced...](#) [View Tutorial](#)

Source: **News & Business > Combined Sources > News, All (English, Full Text)**

Terms: **6700602 or 6,700,602** (Suggest Terms for My Search)

Duplicate Options [What's this?](#)

Select for FOCUS™ or Delivery

- 1. GlobalAdSource (English), June 24, 2006 Saturday, 78 words, THERE'S MORE TO PROTECTING ... ID **6700602** ...
- 2. PR Newswire, July 14, 1993, Wednesday, Financial News, 373 words, XATA CORPORATION REPORTS PROFITABLE THIRD QUARTER RESULTS, BURNSVILLE, Minn., July 1407) [.08) Weighted average common shares outstanding 9,428,577 7,435,973 8,854,491 **6,700,602** The company stated that it was pleased with its first profitable quarter ever and its significant increase in ...
- 3. PR Newswire, August 14, 1992, Friday, Financial News, 330 words, XATA CORPORATION ANNOUNCES RESULTS, BURNSVILLE, Minn., Aug. 1404) [.08) [.15) Weighted average common shares outstanding 7,435,973 4,219,749 **6,700,602** 3,581,992 The company stated that the operating loss was primarily due to increased sales effort, ...

Source: **News & Business > Combined Sources > News, All (English, Full Text)**

Terms: **6700602 or 6,700,602** (Suggest Terms for My Search)

View: Cite

Date/Time: Thursday, August 18, 2011 - 9:08 AM EDT

In

About LexisNexis | Privacy Policy | Terms & Conditions | Contact Us
 Copyright © 2011 LexisNexis, a division of Reed Elsevier Inc. All rights reserved.

Single Search - with Terms and Connectors

Enter keywords - Search multiple dockets & documents

Search

[View Demo](#)
[Search Tips](#)

My CourtLink

Search

Dockets & Documents

Track

Alert

Strategic Profiles

My Account



[Search](#) > [Patent Search](#) > Searching

Patent Search 6,700,602 8/18/2011

No cases found.

Return to Search

(Charges for search still apply)



[About LexisNexis](#) | [Terms & Conditions](#) | [Pricing](#) | [Privacy](#) | [Customer Support](#) - 1-888-311-1966
Copyright © 2011 LexisNexis®. All rights reserved.

PTO/SB/81A (12-08)

Approved for use through 11/30/2011. OMB 0651-0035

U.S. Patent and Trademark Office; U.S. DEPARTMENT OF COMMERCE

Under the Paperwork Reduction Act of 1995, no persons are required to respond to a collection of information unless it displays a valid OMB control number.

PATENT - POWER OF ATTORNEY OR REVOCATION OF POWER OF ATTORNEY WITH A NEW POWER OF ATTORNEY AND CHANGE OF CORRESPONDENCE ADDRESS	Patent Number	6,700,602
	Issue Date	03/02/2004
	First Named Inventor	Scott Blair
	Title	SUBWAY TV MEDIA SYSTEM
	Attorney Docket Number	BLAIR.001A

I hereby revoke all previous powers of attorney given in the above-identified patent.

A Power of Attorney is submitted herewith.

OR

I hereby appoint Practitioner(s) associated with the following Customer Number as my/our attorney(s) or agent(s) with respect to the patent identified above, and to transact all business in the United States Patent and Trademark Office connected therewith: 27299

OR

I hereby appoint Practitioner(s) named below as my/our attorney(s) or agent(s) with respect to the patent identified above, and to transact all business in the United States Patent and Trademark Office connected therewith:

Practitioner(s) Name	Registration Number

Please recognize or change the correspondence address for the above-identified patent to:

The address associated with the above-mentioned Customer Number.

OR

The address associated with Customer Number: 27299

OR

Firm or Individual Name

Address

City State Zip

Country

Telephone Email

I am the:

Inventor, having ownership of the patent.

OR

Patent owner.
Statement under 37 CFR 3.73(b) (Form PTO/SB/96) submitted herewith or filed on _____

SIGNATURE of Inventor or Patent Owner

Signature	<i>Scott Blair</i>	Date	August 16, 2011
Name	SCOTT BLAIR	Telephone	416.860.7160
Title and Company			

NOTE: Signatures of all the inventors or patent owners of the entire interest or their representative(s) are required. Submit multiple forms if more than one signature is required, see below.

*Total of _____ forms are submitted.

This collection of information is required by 37 CFR 1.31, 1.32 and 1.33. The information is required to obtain or retain a benefit by the public which is to file (and by the USPTO to process) an application. Confidentiality is governed by 35 U.S.C. 122 and 37 CFR 1.11 and 1.14. This collection is estimated to take 3 minutes to complete, including gathering, preparing, and submitting the completed application form to the USPTO. Time will vary depending upon the individual case. Any comments on the amount of time you require to complete this form and/or suggestions for reducing this burden, should be sent to the Chief Information Officer, U.S. Patent and Trademark Office, U.S. Department of Commerce, P.O. Box 1450, Alexandria, VA 22313-1450. DO NOT SEND FEES OR COMPLETED FORMS TO THIS ADDRESS. SEND TO: Commissioner for Patents, P.O. Box 1450, Alexandria, VA 22313-1450.

If you need assistance in completing the form, call 1-800-PTO-9199 and select option 2.

Electronic Acknowledgement Receipt

EFS ID:	10778644
Application Number:	90011861
International Application Number:	
Confirmation Number:	3736
Title of Invention:	SUBWAY TV MEDIA SYSTEM
First Named Inventor/Applicant Name:	6700602
Correspondence Address:	SIXBEY FRIEDMAN LEEDOM & FERGUSON - 8180 GREENSBORO DRIVE SUITE 800 MCLEAN VA 22102 US - -
Filer:	Robert F. Gazdzinski/Rebecca Beach
Filer Authorized By:	Robert F. Gazdzinski
Attorney Docket Number:	BLAIR.001A
Receipt Date:	19-AUG-2011
Filing Date:	
Time Stamp:	18:41:43
Application Type:	Reexam (Third Party)

Payment information:

Submitted with Payment	no
------------------------	----

File Listing:

Document Number	Document Description	File Name	File Size(Bytes)/ Message Digest	Multi Part /.zip	Pages (if appl.)
1	Miscellaneous Incoming Letter	Fee_Address.pdf	59226 f5115698dad754348916df56a5ecd899b862691b	no	1

Warnings:

Information:

2	Power of Attorney	POA.pdf	65597 a4dce82d5988fc03c0a4d727ac309d8900361c00	no	1
---	-------------------	---------	---	----	---

Warnings:

Information:

Total Files Size (in bytes):			124823		
-------------------------------------	--	--	--------	--	--

This Acknowledgement Receipt evidences receipt on the noted date by the USPTO of the indicated documents, characterized by the applicant, and including page counts, where applicable. It serves as evidence of receipt similar to a Post Card, as described in MPEP 503.

New Applications Under 35 U.S.C. 111

If a new application is being filed and the application includes the necessary components for a filing date (see 37 CFR 1.53(b)-(d) and MPEP 506), a Filing Receipt (37 CFR 1.54) will be issued in due course and the date shown on this Acknowledgement Receipt will establish the filing date of the application.

National Stage of an International Application under 35 U.S.C. 371

If a timely submission to enter the national stage of an international application is compliant with the conditions of 35 U.S.C. 371 and other applicable requirements a Form PCT/DO/EO/903 indicating acceptance of the application as a national stage submission under 35 U.S.C. 371 will be issued in addition to the Filing Receipt, in due course.

New International Application Filed with the USPTO as a Receiving Office

If a new international application is being filed and the international application includes the necessary components for an international filing date (see PCT Article 11 and MPEP 1810), a Notification of the International Application Number and of the International Filing Date (Form PCT/RO/105) will be issued in due course, subject to prescriptions concerning national security, and the date shown on this Acknowledgement Receipt will establish the international filing date of the application.

Under the Paperwork Reduction Act of 1995, no persons are required to respond to a collection of information unless it displays a valid OMB control number.

"FEE ADDRESS" INDICATION FORM

Address to:
Mail Stop M Correspondence
Commissioner for Patents
P.O. Box 1450
Alexandria, VA 22313-1450

Fax to:
571-273-6500

- OR -

INSTRUCTIONS: The issue fee must have been paid for application(s) listed on this form. In addition, only an address represented by a Customer Number can be established as the fee address for maintenance fee purposes (hereafter, fee address). A fee address should be established when correspondence related to maintenance fees should be mailed to a different address than the correspondence address for the application. **When to check the first box below:** If you have a Customer Number to represent the fee address. **When to check the second box below:** If you have no Customer Number representing the desired fee address, in which case a completed Request for Customer Number (PTO/SB/125) must be attached to this form. For more information on Customer Numbers, see the Manual of Patent Examining Procedure (MPEP) § 403.

For the following listed application(s), please recognize as the "Fee Address" under the provisions of 37 CFR 1.363 the address associated with:

Customer Number: 27299

OR

The attached Request for Customer Number (PTO/SB/125) form.

PATENT NUMBER (if known)	APPLICATION NUMBER
6,700,602	

Completed by (check one):

Applicant/Inventor



Signature

Attorney or Agent of record 39,990
 (Reg. No.)

Robert F. Gazdzinski

Typed or printed name

Assignee of record of the entire interest. See 37 CFR 3.71.
 Statement under 37 CFR 3.73(b) is enclosed.
 (Form PTO/SB/96)

858-675-1670

Requester's telephone number

Assignee recorded at Reel _____ Frame _____

August 19, 2011

Date

NOTE: Signatures of all the inventors or assignees of record of the entire interest or their representative(s) are required. Submit multiple forms if more than one signature is required, see below*.

* Total of _____ forms are submitted.

This collection of information is required by 37 CFR 1.363. The information is required to obtain or retain a benefit by the public which is to file (and by the USPTO to process) an application. Confidentiality is governed by 35 U.S.C. 122 and 37 CFR 1.11 and 1.14. This collection is estimated to take 5 minutes to complete, including gathering, preparing, and submitting the completed application form to the USPTO. Time will vary depending upon the individual case. Any comments on the amount of time you require to complete this form and/or suggestions for reducing this burden, should be sent to the Chief Information Officer, U.S. Patent and Trademark Office, U.S. Department of Commerce, P.O. Box 1450, Alexandria, VA 22313-1450. DO NOT SEND COMPLETE D FORMS TO THIS ADDRESS. SEND TO: Mail Stop M Correspondence, Commissioner for Patents, P.O. Box 1450, Alexandria, VA 22313-1450.

If you need assistance in completing the form, call 1-800-PTO-9199 and select option 2.

**REEXAMINATION TITLE REPORT (AKA PATENT ASSIGNMENT ABSTRACT
OF TITLE)**

TYPE OF REEXAMINATION: XX EX PARTE INTER PARTES

REEXAM CONTROL NO.: 90/011,861

SERIAL NUMBER : 09/423284 FILING DATE: 08/16/11

PATENT NUMBER: 6,700,602 ISSUE DATE 03/02/2004

FIRST THREE INVENTORS' NAMES: Scott Blair

ET. AL?: YES XX NO

CONTINUITY DATA (IF ANY) :

X THIS IS (OR) A __CON__DIV, CIP, A __PROVISIONAL APPLICATION__ OTHER OF
SERIAL NUMBER , INTERNATIONAL FILED ON . STATUS: PATENTED WITH PATENT
NUMBER OR __PENDING, OR __ABANDONED (EXPIRED FOR PROVISIONALS).

__ WHICH IS A __CON, __DIV, __CIP, A __PROVISIONAL APPLICATION, __ OTHER, OF
SERIAL NUMBER FILED ON STATUS: PATENTED, WITH PATENT NUMBER. AND SERIAL
NUMBER FILED PENDING, OR ABANDONED.

__ WHICH IS A __CON, __DIV, __CIP, A __PROVISIONAL APPLICATION, __ OTHER OF SERIAL
NUMBER FILED ON . STATUS: PATENTED WITH PATENT NUMBER OR __PENDING,
OR ABANDONED.

__ WHICH IS A __CON, DIV, __CIP A PROVISIONAL APPLICATION, __ OTHER OF SERIAL
NUMBER FILED ON. STATUS: PATENTED WITH PATENT NUMBER: OR __PENDING, OR
ABANDONED.

__ WHICH IS A CON, DIV, __CIP A PROVISIONAL APPLICATION, __ OTHER OF SERIAL
NUMBER FILED ON. STATUS: PATENTED WITH PATENT NUMBER: OR __PENDING, OR
ABANDONED.

__ WHICH IS A CIP OF SERIAL NUMBER FILED ON. STATUS: PATENTED, WITH PATENT
NUMBER.

ET AL

ASSIGNMENT RECORD DATA

THE ASSIGNMENT RECORDS REVEAL THAT THE TITLE REPORT APPEARS TO BE
VESTED IN:

XX INVENTOR: Toronto, Ontario (CA)

___AS ENDORSED:

___AS THE RECORD STANDS, THE PATENT WHEN GRANTED WILL ISSUE IN THE NAME OF THE INVENTOR(S)

___LEGAL REPRESENTATIVE:

___SECURITY ASSIGNMENT/LICENSEE(PLEASE NOTE THAT THE OWNERSHIP OF THE PATENT IS STILL REFLECTED IN THE ASSIGNOR. THE ASSIGNEE IN THIS CASE CANNOT OWN THE PATENT. (SEE ACCOMPANYING PAGES, IF ANY.)

___WHEN THE ASSIGNMENT IS RECORDED, THE PATENT SHOULD BELONG TO:

___OTHER: REEL NO: FRAME NO.: DATE RECORDED: // COMPANY NAME:
CITY AND STATE OR COUNTRY: .

___NOTES/COMMENTS: Please see section 306 of the Manual of Patent Examining Procedure regarding the *Assignment of a Division, Continuation, Substitute, and Continuation-in-Part in Relation to Parent Application.*

EXAMINED UP TO AND INCLUDING THIS CERTIFICATE DATED AND SIGNED: **08/19/11**

LEGAL INSTRUMENTS EXMR., OFFICE OF PATENT LEGAL ADMIN., CENTRAL
REEXAMINATION UNIT

TO ANY PRINTERS: THE REEXAMINATION TITLE REPORT DOES NOT HAVE TO HAVE THE STREET ADDRESS OF THE OWNER(S). IF THERE IS ANY INQUIRY, PLEASE NOTIFY THE PERSON ABOVE.



UNITED STATES PATENT AND TRADEMARK OFFICE

UNITED STATES DEPARTMENT OF COMMERCE
United States Patent and Trademark Office
Address: COMMISSIONER FOR PATENTS
P.O. Box 1450
Alexandria, Virginia 22313-1450
www.uspto.gov

APPLICATION NUMBER	FILING OR 371(C) DATE	FIRST NAMED APPLICANT	ATTY. DOCKET NO./TITLE
90/011,861	08/16/2011	6700602	BLAIR.001A

CONFIRMATION NO. 3736

POWER OF ATTORNEY NOTICE



27299
GAZDZINSKI & ASSOCIATES, PC
16644 WEST BERNARDO DRIVE
SUITE 201
SAN DIEGO, CA 92127

Date Mailed: 08/23/2011

NOTICE REGARDING CHANGE OF POWER OF ATTORNEY

This is in response to the Power of Attorney filed 08/19/2011.

- The Power of Attorney to you in this application has been revoked by the assignee who has intervened as provided by 37 CFR 3.71. Future correspondence will be mailed to the new address of record(37 CFR 1.33).

/rbell/

Office of Data Management, Application Assistance Unit (571) 272-4000, or (571) 272-4200, or 1-888-786-0101



UNITED STATES PATENT AND TRADEMARK OFFICE

UNITED STATES DEPARTMENT OF COMMERCE
United States Patent and Trademark Office
Address: COMMISSIONER FOR PATENTS
P.O. Box 1450
Alexandria, Virginia 22313-1450
www.uspto.gov

Table with 3 columns: REEXAM CONTROL NUMBER (90/011,861), FILING OR 371 (c) DATE (08/16/2011), PATENT NUMBER (6700602)

27299
GAZDZINSKI & ASSOCIATES, PC
16644 WEST BERNARDO DRIVE
SUITE 201
SAN DIEGO, CA 92127

CONFIRMATION NO. 3736
REEXAMINATION REQUEST
NOTICE



Date Mailed: 08/23/2011

NOTICE OF REEXAMINATION REQUEST FILING DATE
(Patent Owner Requester)

Requester is hereby notified that the filing date of the request for reexamination is 08/16/2011, the date the required fee of \$2,520 was received. (See CFR 1.510(d)).

A decision on the request for reexamination will be mailed within three months from the filing date of the request for reexamination. (See 37 CFR 1.515(a)).

Pursuant to 37 CFR 1.33(c), future correspondence in this reexamination proceeding will be with the latest attorney or agent of the record in the patent file.

The paragraphs checked below are part of this communication:

- 1. The party receiving the courtesy copy is the latest attorney or agent of record in the patent file.
2. The person named to receive the correspondence in this proceeding has not been made the latest attorney or agent of record in the patent file because:
A. Requester's claim of ownership of the patent is not verified by the record.
B. The request papers are not signed with a real or apparent binding signature.
C. The mere naming of a correspondence addressee does not result in that person being appointed as the latest attorney or agent of record in the patent file.
3. Addressee is the latest attorney or agent of record in the patent file.
4. Other

/rbell/

Legal Instruments Examiner
Central Reexamination Unit 571-272-7705; FAX No. 571-273-9900



UNITED STATES PATENT AND TRADEMARK OFFICE

UNITED STATES DEPARTMENT OF COMMERCE
United States Patent and Trademark Office
Address: COMMISSIONER FOR PATENTS
P.O. Box 1450
Alexandria, Virginia 22313-1450
www.uspto.gov

REEXAM CONTROL NUMBER	FILING OR 371 (c) DATE	PATENT NUMBER
90/011,861	08/16/2011	6700602

CONFIRMATION NO. 3736
REEXAM ASSIGNMENT NOTICE

27299
GAZDZINSKI & ASSOCIATES, PC
16644 WEST BERNARDO DRIVE
SUITE 201
SAN DIEGO, CA 92127



Date Mailed: 08/23/2011

NOTICE OF ASSIGNMENT OF REEXAMINATION REQUEST

The above-identified request for reexamination has been assigned to Art Unit 3992. All future correspondence to the proceeding should be identified by the control number listed above and directed to the assigned Art Unit.

A copy of this Notice is being sent to the latest attorney or agent of record in the patent file or to all owners of record. (See 37 CFR 1.33(c)). If the addressee is not, or does not represent, the current owner, he or she is required to forward all communications regarding this proceeding to the current owner(s). An attorney or agent receiving this communication who does not represent the current owner(s) may wish to seek to withdraw pursuant to 37 CFR 1.36 in order to avoid receiving future communications. If the address of the current owner(s) is unknown, this communication should be returned within the request to withdraw pursuant to Section 1.36.

/rbell/

Legal Instruments Examiner
Central Reexamination Unit 571-272-7705; FAX No. 571-273-9900



UNITED STATES PATENT AND TRADEMARK OFFICE

UNITED STATES DEPARTMENT OF COMMERCE
United States Patent and Trademark Office
Address: COMMISSIONER FOR PATENTS
P.O. Box 1450
Alexandria, Virginia 22313-1450
www.uspto.gov

APPLICATION NUMBER	FILING OR 371(C) DATE	FIRST NAMED APPLICANT	ATTY. DOCKET NO./TITLE
90/011,861	08/16/2011	6700602	BLAIR.001A

CONFIRMATION NO. 3736

POA ACCEPTANCE LETTER



27299
GAZDZINSKI & ASSOCIATES, PC
16644 WEST BERNARDO DRIVE
SUITE 201
SAN DIEGO, CA 92127

Date Mailed: 08/23/2011

NOTICE OF ACCEPTANCE OF POWER OF ATTORNEY

This is in response to the Power of Attorney filed 08/19/2011.

The Power of Attorney in this application is accepted. Correspondence in this application will be mailed to the above address as provided by 37 CFR 1.33.

/rbell/

Office of Data Management, Application Assistance Unit (571) 272-4000, or (571) 272-4200, or 1-888-786-0101



UNITED STATES PATENT AND TRADEMARK OFFICE

UNITED STATES DEPARTMENT OF COMMERCE
United States Patent and Trademark Office
Address: COMMISSIONER FOR PATENTS
P.O. Box 1450
Alexandria, Virginia 22313-1450
www.uspto.gov

APPLICATION NO.	FILING DATE	FIRST NAMED INVENTOR	ATTORNEY DOCKET NO.	CONFIRMATION NO.
90/011,861	08/16/2011	6700602	BLAIR.001A	3736

27299 7590 08/25/2011
GAZDZINSKI & ASSOCIATES, PC
16644 WEST BERNARDO DRIVE
SUITE 201
SAN DIEGO, CA 92127

EXAMINER

ART UNIT PAPER NUMBER

DATE MAILED: 08/25/2011

Please find below and/or attached an Office communication concerning this application or proceeding.

Ex Parte Reexamination Interview Summary – Pilot Program for Waiver of Patent Owner's Statement	Control No.	Patent For Which Reexamination is Requested
	90/011,861 Examiner	6,700,602 Art Unit 3992

-- The MAILING DATE of this communication appears on the cover sheet with the correspondence address. --

All participants (USPTO official and patent owner):

- (1) Patricia Volpe, CRU (3)
(2) Peter J. Gutierrez, 56732 (4)

Date of Telephonic Interview: 25 August 2011.

The USPTO official requested waiver of the patent owner's statement pursuant to the pilot program for waiver of patent owner's statement in *ex parte* reexamination proceedings.*

- The patent owner **agreed** to waive its right to file a patent owner's statement under 35 U.S.C. 304 in the event reexamination is ordered for the above-identified patent.
- The patent owner **did not agree** to waive its right to file a patent owner's statement under 35 U.S.C. 304 at this time.

The patent owner is not required to file a written statement of this telephone communication under 37 CFR 1.560(b) or otherwise. However, any disagreement as to this interview summary must be brought to the immediate attention of the USPTO, and no later than one month from the mailing date of this interview summary. Extensions of time are governed by 37 CFR 1.550(c).

*For more information regarding this pilot program, see *Pilot Program for Waiver of Patent Owner's Statement in Ex Parte Reexamination Proceedings*, 75 Fed. Reg. 47269 (August 5, 2010), available on the USPTO Web site at <http://www.uspto.gov/patents/law/notices/2010.jsp>.

- USPTO personnel were unable to reach the patent owner.

The patent owner may contact the USPTO personnel at the telephone number provided below if the patent owner decides to waive the right to file a patent owner's statement under 35 U.S.C. 304.

/Patricia Volpe/ (571) 272-6825
Signature and telephone number of the USPTO official who contacted or attempted to contact the patent owner.

cc: Requester (if third party requester)



UNITED STATES PATENT AND TRADEMARK OFFICE

UNITED STATES DEPARTMENT OF COMMERCE
United States Patent and Trademark Office
Address: COMMISSIONER FOR PATENTS
P.O. Box 1450
Alexandria, Virginia 22313-1450
www.uspto.gov

APPLICATION NO.	FILING DATE	FIRST NAMED INVENTOR	ATTORNEY DOCKET NO.	CONFIRMATION NO.
90/011,861	08/16/2011	6700602	BLAIR.001A	3736

27299 7590 09/29/2011
GAZDZINSKI & ASSOCIATES, PC
16644 WEST BERNARDO DRIVE
SUITE 201
SAN DIEGO, CA 92127

EXAMINER

ART UNIT PAPER NUMBER

DATE MAILED: 09/29/2011

Please find below and/or attached an Office communication concerning this application or proceeding.

Order Granting / Denying Request For Ex Parte Reexamination	Control No.	Patent Under Reexamination
	90/011,861	6700602
	Examiner	Art Unit
	STEPHEN RALIS	3992

--The MAILING DATE of this communication appears on the cover sheet with the correspondence address--

The request for *ex parte* reexamination filed 16 August 2011 has been considered and a determination has been made. An identification of the claims, the references relied upon, and the rationale supporting the determination are attached.

Attachments: a) PTO-892, b) PTO/SB/08, c) Other: _____

1. The request for *ex parte* reexamination is GRANTED.

RESPONSE TIMES ARE SET AS FOLLOWS:

For Patent Owner's Statement (Optional): **TWO MONTHS** from the mailing date of this communication (37 CFR 1.530 (b)). **EXTENSIONS OF TIME ARE GOVERNED BY 37 CFR 1.550(c).**

For Requester's Reply (optional): **TWO MONTHS** from the **date of service** of any timely filed Patent Owner's Statement (37 CFR 1.535). **NO EXTENSION OF THIS TIME PERIOD IS PERMITTED.** If Patent Owner does not file a timely statement under 37 CFR 1.530(b), then no reply by requester is permitted.

2. The request for *ex parte* reexamination is DENIED.

This decision is not appealable (35 U.S.C. 303(c)). Requester may seek review by petition to the Commissioner under 37 CFR 1.181 within **ONE MONTH** from the mailing date of this communication (37 CFR 1.515(c)). **EXTENSION OF TIME TO FILE SUCH A PETITION UNDER 37 CFR 1.181 ARE AVAILABLE ONLY BY PETITION TO SUSPEND OR WAIVE THE REGULATIONS UNDER 37 CFR 1.183.**

In due course, a refund under 37 CFR 1.26 (c) will be made to requester:

- a) by Treasury check or,
b) by credit to Deposit Account No. _____, or
c) by credit to a credit card account, unless otherwise notified (35 U.S.C. 303(c)).

--	--	--

cc:Requester (if third party requester)

DECISION

1. A substantial new question of patentability affecting claim 1 of United States Patent Number 6,700,602 is raised by the Request for *ex parte* reexamination.

Extensions of time under 37 CFR 1.136(a) will not be permitted in these proceedings because the provisions of 37 CFR 1.136 apply only to "an applicant" and not to parties in a reexamination proceeding. Additionally, 35 U.S.C. 305 requires that *ex parte* reexamination proceedings "will be conducted with special dispatch" (37 CFR 1.550(a)). Extensions of time in *ex parte* reexamination proceedings are provided for in 37 CFR 1.550(c).

References Cited in Request

2. A total of four references, in certain combinations, have been asserted in the request as providing teachings relevant to the claims of the Blair patent. The proposed references which make up the combinations are as follows:

Minesaki et al. (Japanese Publication No. JP 63-125984 of Japanese Application No. JP 61-272668)

Amano et al. (Japanese Publication No. JP 02-23985 A)

Maekawa et al. (Japanese Publication No. JP 04-160991 A)

Shinagawa et al. (Japanese Publication No. JP S61-285490)

Identification of Every Claim for Which Reexamination is Requested

Art Unit: 3992

3. The four references cited above are discussed in the Request as reading on claim 1 of the Blair patent. Pages 4-5 of the Request detail out proposed substantial new questions of patentability in light of the combination of the four references cited above.

Prosecution History

4. The Blair patent was assigned serial number 09/423,284. During the original prosecution, the original examiner issued a first non-Final Office action on 19 November 2002 rejecting claims 1-12 and 14-16 while objecting to claim 13 as being "allowable if rewritten in independent form including all of the limitations of the base claim and intervening claims" (page 4, Office action mailed 19 November 2002). Claim amendment and arguments submitted 24 February 2003 canceled claims 1-3, 6 and 8-12 while amending claims 4, 5, 7 and 13-16 (i.e. specifically placing claim 13 in independent form, as set forth previously by the original examiner in the Office action mailed 19 November 2002). The original examiner followed with another non-Final Office action, with more prior art, rejecting in totality claims 4, 5, 7 and 13-16. Further claim arguments, submitted 14 October 2003, asserted to the original examiner that the limitation of "the screen of the monitor substantially flushed with the adjacent wall surface structure of the car" was not taught in any of the prior art of record. A "Notice of Allowability" was issued by the original examiner on 17 November 2003 with the examiner citing the entire claim as being the reason for allowance. While the examiner did not specifically provide a particular portion of claim 13 in the "Reason for Allowance"

Art Unit: 3992

statement, applicant's remarks/arguments indicate that allowability was designated based on the "the screen of the monitor substantially flushed with the adjacent wall surface structure of the car" feature of the subway car.

None of the four references in the currently filed Request were previously discussed by the original examiner or applied to claim 1 in the prosecution history of the Blair patent.

Substantial New Questions (SNQ) of Patentability

5. Applicant's remarks/arguments, filed 14 October 2003, will be utilized to show why the newly cited references above do or do not create a substantial new question (SNQ) of patentability.
6. For purposes of determination, independent claim 1 is used as the representative claim for the various proposed prior art listed below. The italicized/underlined sections of the claim below are utilized by the examiner to show how specific teachings of the proposed references create a substantial new question of patentability in light of the original prosecution history above.

Claim 1:

A subway car for mass transportation including longitudinal opposed sidewalls, a ceiling adjoining the sidewalls, *a video display system comprising a plurality of video display monitors each having a video screen,* and a video signal source unit operatively connected to said monitors, said monitors being spaced along the length of the car on opposed sides thereof, each of said monitor being mounted at the junction of the sidewall and ceiling, *with the screen of the monitor substantially flushed with the adjacent wall surface structure of the car,* and

Art Unit: 3992

directed obliquely downwardly toward the car seats, so that each video screen is readily visible to passengers in the subway car.

Minesaki et al.

7. Minesaki et al. teaches a train car for mass transportation.

The Request appears to show that Minesaki et al., for claim 1, teaches a video display system comprising a plurality of video display monitors each having a video screen as well as the screen of the monitor substantially flushed with the adjacent wall surface structure of the car. (See Figure 2; see Request claim mapping, Request mapping pages 4-5).

Minesaki et al. was not of record in the original prosecution of U.S. Patent No. 6,700,602.

It is agreed that the consideration of Minesaki et al. raises a substantial new question of patentability of at least claim 1 as pointed out above. There is a substantial likelihood that a reasonable examiner would consider these teachings important in deciding whether or not these claims are patentable.

Amano et al.

8. Amano et al. teaches an electric train car for mass transportation.

The Request appears to show that Amano et al., for claim 1, teaches a video display system comprising a plurality of video display monitors each having a video screen as well as the screen of the monitor substantially flushed with the adjacent wall

Art Unit: 3992

surface structure of the car. (See Figures 4-6; see Request claim mapping, Request mapping pages 4-5).

Amano et al. was not of record in the original prosecution of U.S. Patent No. 6,700,602.

It is agreed that the consideration of Amano et al. raises a substantial new question of patentability of at least claim 1 as pointed out above. There is a substantial likelihood that a reasonable examiner would consider these teachings important in deciding whether or not these claims are patentable.

Maekawa et al.

9. Maekawa et al. teaches a train car for mass transportation.

The Request appears to show that Maekawa et al., for claim 1, teaches a video display system comprising a plurality of video display monitors each having a video screen as well as the screen of the monitor substantially flushed with the adjacent wall surface structure of the car. (See Figures 1, 2; see Request claim mapping, Request mapping pages 4-5).

Maekawa et al. was not of record in the original prosecution of U.S. Patent No. 6,700,602.

It is agreed that the consideration of Maekawa et al. raises a substantial new question of patentability of at least claim 1 as pointed out above. There is a substantial likelihood that a reasonable examiner would consider these teachings important in deciding whether or not these claims are patentable.

Shinagawa et al.

10. Shinagawa et al. teaches a transportation train car for mass transportation.

The Request appears to show that Shinagawa et al., for claim 1, teaches a video display system comprising a plurality of video display monitors each having a video screen as well as the screen of the monitor substantially flushed with the adjacent wall surface structure of the car. (See Figures 1, 4; see Request claim mapping, Request mapping pages 4-5).

Shinagawa et al. was not of record in the original prosecution of U.S. Patent No. 6,700,602.

It is agreed that the consideration of Shinagawa et al. raises a substantial new question of patentability of at least claim 1 as pointed out above. There is a substantial likelihood that a reasonable examiner would consider these teachings important in deciding whether or not these claims are patentable.

Summary

11. Claim 1 of the Blair patent will be reexamined as requested in the Order.

Art Unit: 3992

Conclusion

Extensions of time under 37 CFR 1.136(a) will not be permitted in these proceedings because the provisions of 37 CFR 1.136 apply only to "an applicant" and not to parties in a reexamination proceeding. Additionally, 35 U.S.C. 305 requires that reexamination proceedings "will be conducted with special dispatch" (37 CFR 1.550(a)). Extension of time in *ex parte* reexamination proceedings are provided for in 37 CFR 1.550(c).

The patent owner is reminded of the continuing responsibility under 37 CFR 1.565(a), to apprise the Office of any litigation activity, or other prior or concurrent proceeding, involving Patent No. 6,700,602 throughout the course of this reexamination proceeding. See MPEP §§ 2207, 2282 and 2286.

All correspondence relating to this *ex parte* reexamination proceeding should be directed:

By Mail to: Mail Stop *Ex Parte* Reexam
 Central Reexamination Unit
 Commissioner for Patents
 United States Patent & Trademark Office
 P.O. Box 1450
 Alexandria, VA 22313-1450

By FAX to: (571) 273-9900
 Central Reexamination Unit

By hand: Customer Service Window
 Randolph Building
 401 Dulany Street
 Alexandria, VA 22314

By EFS-Web:

Art Unit: 3992

Registered users 99999 of EFS-Web may alternatively submit such correspondence via the electronic filing system EFS-Web, at

<https://sportal.uspto.gov/authenticate/authenticateuserlocalepf.html>

EFS-Web offers the benefit of quick submission to the particular area of the Office that needs to act on the correspondence. Also, EFS-Web submissions are "soft scanned" (i.e., electronically uploaded) directly into the official file for the reexamination proceeding, which offers parties the opportunity to review the content of their submissions after the "soft scanning" process is complete.

Any inquiry concerning this communication or earlier communications from the Reexamination Legal Advisor or Examiner, or as to the status of this proceeding, should be directed to the Central Reexamination Unit at telephone number (571) 272-7705.

/Stephen J Ralis/
Primary Examiner, Art Unit 3992

Conferee

EBK

Conferee

ATK

Reexamination 	Application/Control No. 90011861	Applicant(s)/Patent Under Reexamination 6700602
	Certificate Date	Certificate Number

Requester Correspondence Address: **Patent Owner** **Third Party**

GAZDZINSKI & ASSOCIATES, PC
 16644 WEST BERNARDO DRIVE
 SUITE 201
 SAN DIEGO, CA 92127

LITIGATION REVIEW <input checked="" type="checkbox"/>	SR (examiner initials)	09/27/2011 (date)
Case Name		Director Initials
No Litigation is currently pending.		<i>MSK fv SY</i>

COPENDING OFFICE PROCEEDINGS	
TYPE OF PROCEEDING	NUMBER
1. No copending proceedings.-	

--	--

Search Notes 	Application/Control No. 90011861	Applicant(s)/Patent Under Reexamination 6700602
	Examiner STEPHEN RALIS	Art Unit 3992

SEARCHED			
Class	Subclass	Date	Examiner

SEARCH NOTES		
Search Notes	Date	Examiner
Reviewed proposed prior art and patent prosecution history.		

INTERFERENCE SEARCH			
Class	Subclass	Date	Examiner

--	--



UNITED STATES PATENT AND TRADEMARK OFFICE

UNITED STATES DEPARTMENT OF COMMERCE
United States Patent and Trademark Office
Address: COMMISSIONER FOR PATENTS
P.O. Box 1450
Alexandria, Virginia 22313-1450
www.uspto.gov

APPLICATION NO.	FILING DATE	FIRST NAMED INVENTOR	ATTORNEY DOCKET NO.	CONFIRMATION NO.
90/011,861	08/16/2011	6700602	BLAIR.001A	3736

27299 7590 01/11/2012
GAZDZINSKI & ASSOCIATES, PC
16644 WEST BERNARDO DRIVE
SUITE 201
SAN DIEGO, CA 92127

EXAMINER

ART UNIT	PAPER NUMBER
----------	--------------

DATE MAILED: 01/11/2012

Please find below and/or attached an Office communication concerning this application or proceeding.

Office Action in Ex Parte Reexamination	Control No. 90/011,861	Patent Under Reexamination 6700602
	Examiner STEPHEN RALIS	Art Unit 3992

-- The MAILING DATE of this communication appears on the cover sheet with the correspondence address --

- a Responsive to the communication(s) filed on _____. b This action is made FINAL.
c A statement under 37 CFR 1.530 has not been received from the patent owner.

A shortened statutory period for response to this action is set to expire 2 month(s) from the mailing date of this letter. Failure to respond within the period for response will result in termination of the proceeding and issuance of an *ex parte* reexamination certificate in accordance with this action. 37 CFR 1.550(d). **EXTENSIONS OF TIME ARE GOVERNED BY 37 CFR 1.550(c).** If the period for response specified above is less than thirty (30) days, a response within the statutory minimum of thirty (30) days will be considered timely.

Part I THE FOLLOWING ATTACHMENT(S) ARE PART OF THIS ACTION:

1. Notice of References Cited by Examiner, PTO-892. 3. Interview Summary, PTO-474.
2. Information Disclosure Statement, PTO/SB/08. 4. _____.

Part II SUMMARY OF ACTION

- 1a. Claims 1 are subject to reexamination.
1b. Claims _____ are not subject to reexamination.
2. Claims _____ have been canceled in the present reexamination proceeding.
3. Claims _____ are patentable and/or confirmed.
4. Claims 1 are rejected.
5. Claims _____ are objected to.
6. The drawings, filed on _____ are acceptable.
7. The proposed drawing correction, filed on _____ has been (7a) approved (7b) disapproved.
8. Acknowledgment is made of the priority claim under 35 U.S.C. § 119(a)-(d) or (f).
a) All b) Some* c) None of the certified copies have
1 been received.
2 not been received.
3 been filed in Application No. _____.
4 been filed in reexamination Control No. _____.
5 been received by the International Bureau in PCT application No. _____.
* See the attached detailed Office action for a list of the certified copies not received.
9. Since the proceeding appears to be in condition for issuance of an *ex parte* reexamination certificate except for formal matters, prosecution as to the merits is closed in accordance with the practice under *Ex parte* Quayle, 1935 C.D. 11, 453 O.G. 213.
10. Other: _____

cc: Requester (if third party requester)

DETAILED ACTION

1. This Office action addresses claim 1 of United States Patent Number 6,700,602 (Blair) for which it has been determined in the Order Granting *Ex Partes* Reexamination (hereafter the "Order") that a substantial new question of patentability was raised in the Request for ex parte reexamination filed on 29 September 2011 (hereafter the "Request").

Rejections Proposed by the Requester

2. A total of four references have been asserted in the Request as providing teachings relevant to the claims of the Blair patent. In view of the Order, all references raised a substantial new question of patentability. The following proposed rejections are the main issues to be discussed below:

Art Unit: 3992

- Issue 1: Claim 1 in view of Minesaki.
- Issue 2: Claim 1 in view of Amano et al.
- Issue 3: Claim 1 in view of Maekawa et al. and Amano et al.
- Issue 4: Claim 1 in view of Shinagawa et al. and Amano et al.
- Issue 5: Claim 1 in view of Minesaki and Moore et al.
- Issue 6: Claim 1 in view of Amano et al. and Moore et al.
- Issue 7: Claim 1 in view of Maekawa et al., Amano et al. and Moore et al.
- Issue 8: Claim 1 in view of Shinagawa et al., Amano et al. and Moore et al.

The rejection below is confined to what has been deemed to be the best available art from the Request. However, prior to conclusion of this reexamination proceeding, claims must be patentable over all prior art cited in the order granting reexamination in order to be considered patentable or confirmed on the reexamination certificate.

Claim Rejection Paragraphs

3. The following quotations from the MPEP regarding the types of rejections to be utilized below:

Claim Rejections - 35 USC § 102

4. The following is a quotation of the appropriate paragraphs of 35 U.S.C. 102 that form the basis for the rejections under this section made in this Office action:

Art Unit: 3992

A person shall be entitled to a patent unless –

(b) the invention was patented or described in a printed publication in this or a foreign country or in public use or on sale in this country, more than one year prior to the date of application for patent in the United States.

Claim Rejections - 35 USC § 103

5. The following is a quotation of 35 U.S.C. 103(a) which forms the basis for all obviousness rejections set forth in this Office action:

(a) A patent may not be obtained though the invention is not identically disclosed or described as set forth in section 102 of this title, if the differences between the subject matter sought to be patented and the prior art are such that the subject matter as a whole would have been obvious at the time the invention was made to a person having ordinary skill in the art to which said subject matter pertains. Patentability shall not be negated by the manner in which the invention was made.

Issue 1

6. Claim 1 is rejected under 35 U.S.C. 102(b) as being anticipated by Minesaki (Japanese Publication No. JP 63-125984 of Japanese Application No. JP 61-272668).

Minesaki discloses a subway car (train cars; page 588, lines 6-10; page 590, lines 18-19) for mass transportation including longitudinal opposed sidewalls (9), a ceiling (top portion in Figure 2) adjoining the sidewalls (9), a video display system (control part G/information communication display part J combination) comprising a plurality of video display monitors (see references to J on each side of sidewall 9 and ceiling interface in Figure 2) each having a video screen (display), and a video signal source unit (control part G) operatively connected to the monitors (see references to J on each side of sidewall 9 and ceiling interface in Figure 2), the monitors (see references to J on each side of sidewall 9 and ceiling interface in Figure 2) being spaced along the length of the car on opposed sides thereof (in the middle of the length

Art Unit: 3992

of each sidewall opposite each other; see Figure 2), each of the monitors being mounted at the junction of the sidewall and ceiling (see Figure 2), with the screen (display) of the monitor (see one of references to J on each side of sidewall 9 and ceiling interface in Figure 2) substantially flushed with the adjacent wall surface structure of the car (see Figure 2), and directed obliquely downwardly toward the car seats (top portion of Information communication part J directed obliquely downwardly toward the car seats; see Figure 2) , so that each video screen (display) is readily visible to passengers in the subway car (train cars; page 588, lines 6-10; page 590, lines 18-19)

With respect to the limitation of “the screen of the monitor substantially flushed with the adjacent wall surface structure of the car”, the term “substantially” is often used in conjunction with another term to describe a particular characteristic of the claimed invention. It is a broad term. (See MPEP 2173.05). Minesaki explicitly discloses the screen (display) of the monitor (see one of references to J on each side of sidewall 9 and ceiling interface in Figure 2) being substantially flushed with the adjacent wall surface structure of the car (see Figure 2) given its broadest reasonable interpretation of “substantially flushed” in light of the Blair Patent disclosure (column 5, line 35 – column 6, line 7; see Figures 4A-7). Therefore, Minesaki fully meets “the screen of the monitor substantially flushed with the adjacent wall surface structure of the car” given its broadest reasonable interpretation.

Issue 2

Art Unit: 3992

7. Claim 1 is rejected under 35 U.S.C. 102(b) as being anticipated by Amano et al. (Japanese. Publication No. JP 02-23985 A).

Amano et al. discloses a subway car (train cars; page 651, column 2, lines 5-10, 28-33; page 653, column 1, lines 43-45; see Figures 4-6) for mass transportation including longitudinal opposed sidewalls (see Figures 4-6), a ceiling (see Figures 4-6) adjoining the sidewalls (see Figures 4-6), a video display system (see Figure 2) comprising a plurality of video display monitors (8; 8a-8n; see Figures 2, 4-6) each having a video screen (display), and a video signal source unit (display information signal transmitter) operatively connected to the monitors (8; 8a-8n; see Figures 2, 4-6), the monitors (8; 8a-8n; see Figures 2, 4-6) being spaced along the length of the car on opposed sides thereof (in the middle of the length of each sidewall opposite each other; see Figures 4-6), each of the monitors being mounted at the junction of the sidewall and ceiling (see Figures 4-6), with the screen (display) of the monitor (8; 8a-8n; see Figures 2, 4-6) substantially flushed with the adjacent wall surface structure of the car (see Figure 4-6), and directed obliquely downwardly toward the car seats (see Figures 4-6) , so that each video screen (display) is readily visible to passengers in the subway car (train cars; page 651, column 2, lines 5-10, 28-33; page 653, column 1, lines 43-45; see Figures 4-6).

With respect to the limitation of “the screen of the monitor substantially flushed with the adjacent wall surface structure of the car”, the term “substantially” is often used in conjunction with another term to describe a particular characteristic of the claimed invention. It is a broad term. (See MPEP 2173.05). Minesaki explicitly discloses the

Art Unit: 3992

screen (display) of the monitor (8; 8a-8n; see Figures 2, 4-6) substantially flushed with the adjacent wall surface structure of the car (see Figures 4-6) given its broadest reasonable interpretation of "substantially flushed" in light of the Blair Patent disclosure (column 5, line 35 – column 6, line 7; see Figures 4A-7). Therefore, Amano et al. fully meets "the screen of the monitor substantially flushed with the adjacent wall surface structure of the car" given its broadest reasonable interpretation.

Issue 3

8. Claim 1 is rejected under 35 U.S.C. 103(a) as being unpatentable over Maekawa et al. (Japanese. Publication No. JP 04-160991 A) in view of Amano et al. (Japanese. Publication No. JP 02-23985 A).

Maekawa et al. discloses a subway car (car body of an electric train; page 738, column 2; see Figures 1, 2) for mass transportation including longitudinal opposed sidewalls (see Figures 1, 2), a ceiling (see Figures 1, 2) adjoining the sidewalls (see Figures 1, 2), a video display system (see Figure 1) comprising a plurality of video display monitors (101-124; page 738, column 2; see Figures 1, 2) each having a video screen (display), and a video signal source unit (see Figure 1) operatively connected to the monitors (101-124; page 738, column 2; see Figures 1, 2), the monitors (101-124; page 738, column 2; see Figures 1, 2) being spaced along the length of the car on opposed sides thereof (see Figures 1, 2), with the screen (display) of the monitor (101-124; page 738, column 2; see Figures 1, 2) substantially flushed with the adjacent wall surface structure of the car (see Figure 2), so that each video screen (display) is readily

Art Unit: 3992

visible to passengers in the subway car (car body of an electric train; page 738, column 2; see Figures 1, 2).

With respect to the limitation of “the screen of the monitor substantially flushed with the adjacent wall surface structure of the car”, the term “substantially” is often used in conjunction with another term to describe a particular characteristic of the claimed invention. It is a broad term. (See MPEP 2173.05). Maekawa et al. explicitly discloses the screen (display) of the monitor (101-124; page 738, column 2; see Figures 1, 2) substantially flushed with the adjacent wall surface structure of the car (see Figure 2) given its broadest reasonable interpretation of “substantially flushed” in light of the Blair Patent disclosure (column 5, line 35 – column 6, line 7; see Figures 4A-7). Therefore, Amano et al. fully meets “the screen of the monitor substantially flushed with the adjacent wall surface structure of the car” given its broadest reasonable interpretation.

Maekawa et al. discloses all of the limitations of the claimed invention, as previously set forth, except for specifically calling for each of the monitors being mounted at the junction of the sidewall and ceiling and directed obliquely downwardly toward the car seats.

However, each of the monitors being mounted at the junction of the sidewall and ceiling and directed obliquely downwardly toward the car seats is known in the art. Amano et al., for example, teaches each of the monitors being mounted at the junction of the sidewall and ceiling (see Figures 4-6) and directed obliquely downwardly toward the car seats (see Figures 4-6). Amano et al. further teaches such a configuration presents a means to provide the offering place for information in transportation

Art Unit: 3992

equipment being used more effectively and sharpness being obtained, thereby increasing the information offering ability to passengers (English translation Abstract). It would have been obvious to one of ordinary skill in the art at the time of the invention was made to modify the mounting and screen direction orientation of the monitors of Maekawa et al. with each of the monitors being mounted at the junction of the sidewall and ceiling and directed obliquely downwardly toward the car seats of Amano et al. in order to present a means to provide the offering place for information in transportation equipment being used more effectively and sharpness being obtained, thereby increasing the information offering ability to passengers.

Issue 4

9. Claim 1 is rejected under 35 U.S.C. 103(a) as being unpatentable over Shinagawa et al. (Japanese. Publication No. JP 04-160991 A) in view of Amano et al. (Japanese. Publication No. JP 02-23985 A).

Shinagawa et al. discloses a subway car (car of a train; page 619, column 1; see Figure 4) for mass transportation including longitudinal opposed sidewalls (see Figure 4), a ceiling (see Figure 4) adjoining the sidewalls (see Figure 4), a video display system (see Figure 1) comprising a plurality of video display monitors (21-2n; page 621, column 1; see Figures 1, 4) each having a video screen (display), and a video signal source unit (see Figure 1) operatively connected to the monitors (21-2n; page 621, column 1; see Figures 1, 4), the monitors (21-2n; page 621, column 1; see Figures 1, 4) being spaced along the length of the car on opposed sides thereof (page 621, column 1,

Art Unit: 3992

paragraph 3; see Figures 1, 4), with the screen (display) of the monitor (21-2n; page 621, column 1; see Figures 1, 4) substantially flushed with the adjacent wall surface structure of the car ("arranged on the walls or above the windows" would be "substantially flushed with the adjacent wall surface structure of the car"; page 621), so that each video screen (display) is readily visible to passengers in the subway car (car of a train; page 619, column 1; see Figure 4).

With respect to the limitation of "the screen of the monitor substantially flushed with the adjacent wall surface structure of the car", the term "substantially" is often used in conjunction with another term to describe a particular characteristic of the claimed invention. It is a broad term. (See MPEP 2173.05). Shinagawa et al. explicitly discloses the screen (display) of the monitor (21-2n; page 621, column 1; see Figures 1, 4) substantially flushed with the adjacent wall surface structure of the car (see Figure 2), since such an arrangement would place the monitors substantially flushed with an adjacent wall structure (i.e. wall planar with the windows), given its broadest reasonable interpretation of "substantially flushed" in light of the Blair Patent disclosure (column 5, line 35 – column 6, line 7; see Figures 4A-7). Therefore, Shinagawa et al. fully meets "the screen of the monitor substantially flushed with the adjacent wall surface structure of the car" given its broadest reasonable interpretation.

Shinagawa et al. discloses all of the limitations of the claimed invention, as previously set forth, except for specifically calling for each of the monitors being mounted at the junction of the sidewall and ceiling and directed obliquely downwardly toward the car seats.

Art Unit: 3992

However, each of the monitors being mounted at the junction of the sidewall and ceiling and directed obliquely downwardly toward the car seats is known in the art. Amano et al., for example, teaches each of the monitors being mounted at the junction of the sidewall and ceiling (see Figures 4-6) and directed obliquely downwardly toward the car seats (see Figures 4-6). Amano et al. further teaches such a configuration presents a means to provide the offering place for information in transportation equipment being used more effectively and sharpness being obtained, thereby increasing the information offering ability to passengers (English translation Abstract). It would have been obvious to one of ordinary skill in the art at the time of the invention was made to modify the mounting and screen direction orientation of the monitors of Shinagawa et al. with each of the monitors being mounted at the junction of the sidewall and ceiling and directed obliquely downwardly toward the car seats of Amano et al. in order to present a means to provide the offering place for information in transportation equipment being used more effectively and sharpness being obtained, thereby increasing the information offering ability to passengers.

10. To the degree it can be argued that "Minesaki", "Amano et al.", "Maekawa et al." and/or "Shinagawa et al." do not disclose "the screen of the monitor substantially flushed with the adjacent wall surface structure of the car" given their broadest reasonable interpretation, the additional rejections are provided as set forth below:

Issue 5

Art Unit: 3992

11. Claim 1 is rejected under 35 U.S.C. 103(a) as being unpatentable over Minesaki (Japanese. Publication No. JP 63-125984 of Japanese Application No. JP 61-272668) in view of Moore et al. (U.S. Patent No. 3,480,727).

Minesaki discloses a subway car (train cars; page 588, lines 6-10; page 590, lines 18-19) for mass transportation including longitudinal opposed sidewalls (9), a ceiling (top portion in Figure 2) adjoining the sidewalls (9), a video display system (control part G/information communication display part J combination) comprising a plurality of video display monitors (see references to J on each side of sidewall 9 and ceiling interface in Figure 2) each having a video screen (display), and a video signal source unit (control part G) operatively connected to the monitors (see references to J on each side of sidewall 9 and ceiling interface in Figure 2), the monitors (see references to J on each side of sidewall 9 and ceiling interface in Figure 2) being spaced along the length of the car on opposed sides thereof (in the middle of the length of each sidewall opposite each other; see Figure 2), each of the monitors being mounted at the junction of the sidewall and ceiling (see Figure 2), with the screen (display) of the monitor being projecting slightly beyond the adjacent wall surface structure of the car (see Figure 2) and directed obliquely downwardly toward the car seats (top portion of Information communication part J directed obliquely downwardly toward the car seats; see Figure 2), so that each video screen (display) is readily visible to passengers in the subway car (train cars; page 588, lines 6-10; page 590, lines 18-19).

Minesaki discloses all of the limitations of the claimed invention, as previously set forth, except for specifically calling for the screen of the monitor being substantially flushed with the adjacent wall surface structure instead of the monitor being projecting slightly beyond the adjacent wall surface structure.

However, a screen of the monitor being substantially flushed with the adjacent wall surface structure is known in the art. Moore et al., for example, teach a screen of the monitor being substantially flushed with the adjacent wall surface structure as being an equivalent structure in the art (column 7, lines 41-44). Moore et al. further teaches such a configuration provides a means to compensate for wall thickness or, the availability of space beyond the surface of the wall (column 7, lines 44-47). It would have been obvious to one of ordinary skill in the art at the time of the invention was made to modify the monitor being projecting slightly beyond the adjacent wall surface structure of the car of Minesaki with the screen of the monitor being substantially flushed with the adjacent wall surface structure of Moore et al. in order to provide a means to compensate for wall thickness or, the availability of space beyond the surface of the wall. In addition, because these two monitor/wall configurations were art recognized equivalents at the time the invention was made, one of ordinary skill in the art would have found it obvious to substitute a screen of the monitor being substantially flushed with the adjacent wall surface structure for a monitor being projecting slightly beyond the adjacent wall surface structure.

Similarly, the examiner asserts that applying a known technique to a known device ready for improvement would yield predictable results. That is, it would have

Art Unit: 3992

been recognized by one of ordinary skill in the art that applying the known technique taught by Moore et al. to the subway car of Minesaki would have yielded predictable results and resulted in an improved system, namely, a screen of the monitor being substantially flushed with the adjacent wall surface structure for a monitor being projecting slightly beyond the adjacent wall surface structure in Minesaki to provide a means to compensate for wall thickness or, the availability of space beyond the surface of the wall.

Moreover, the examiner asserts that simple substitution of one known element for another would obtain predictable results. That is, the substitution of one known element (a screen of the monitor being substantially flushed with the adjacent wall surface structure as shown in Moore et al.) for another (a monitor being projecting slightly beyond the adjacent wall surface structure as shown in Moore et al. and Minesaki) would have been obvious to one of ordinary skill in the art at the time of the invention since the substitution of a screen of the monitor being substantially flushed with the adjacent wall surface structure in Minesaki would have yielded predictable results, namely, providing a screen of the monitor being substantially flushed with the adjacent wall surface structure in Minesaki to provide a means to compensate for wall thickness or, the availability of space beyond the surface of the wall.

Furthermore, the examiner asserts use of known technique to improve similar devices in the same way is obvious to one of ordinary skill in the art. That is, the manner of enhancing a particular device (providing a screen of the monitor being substantially flushed with the adjacent wall surface structure) was made part of the ordinary

Art Unit: 3992

capabilities of one skilled in the art based upon the teaching of such improvement in Moore et al. Accordingly, one of ordinary skill in the art would have been capable of applying this known "improvement" technique in the same manner to the prior art subway car of Minesaki and the results would have been predictable to one of ordinary skill in the art, namely, one skilled in the art would have readily recognized that providing a screen of the monitor being substantially flushed with the adjacent wall surface structure in Minesaki would positively provide a means to compensate for wall thickness or, the availability of space beyond the surface of the wall.

Issue 6

12. Claim 1 is rejected under 35 U.S.C. 103(a) as being unpatentable over Amano et al. (Japanese. Publication No. JP 02-23985 A) in view of Moore et al. (U.S. Patent No. 3,480,727).

Amano et al. discloses a subway car (train cars; page 651, column 2, lines 5-10, 28-33; page 653, column 1, lines 43-45; see Figures 4-6) for mass transportation including longitudinal opposed sidewalls (see Figures 4-6), a ceiling (see Figures 4-6) adjoining the sidewalls (see Figures 4-6), a video display system (see Figure 2) comprising a plurality of video display monitors (8; 8a-8n; see Figures 2, 4-6) each having a video screen (display), and a video signal source unit (display information signal transmitter) operatively connected to the monitors (8; 8a-8n; see Figures 2, 4-6), the monitors (8; 8a-8n; see Figures 2, 4-6) being spaced along the length of the car on opposed sides thereof (in the middle of the length of each sidewall opposite each other;

Art Unit: 3992

see Figures 4-6), each of the monitors being mounted at the junction of the sidewall and ceiling (see Figures 4-6), with the screen (display) of the monitor being projecting slightly beyond the adjacent wall surface structure of the car (see Figures 4-6) and directed obliquely downwardly toward the car seats (see Figures 4-6) , so that each video screen (display) is readily visible to passengers in the subway car (train cars; page 651, column 2, lines 5-10, 28-33; page 653, column 1, lines 43-45; see Figures 4-6).

Amano et al. discloses all of the limitations of the claimed invention, as previously set forth, except for specifically calling for the screen of the monitor being substantially flushed with the adjacent wall surface structure instead of the monitor being projecting slightly beyond the adjacent wall surface structure.

However, a screen of the monitor being substantially flushed with the adjacent wall surface structure is known in the art. Moore et al., for example, teach a screen of the monitor being substantially flushed with the adjacent wall surface structure as being an equivalent structure in the art (column 7, lines 41-44). Moore et al. further teaches such a configuration provides a means to compensate for wall thickness or, the availability of space beyond the surface of the wall (column 7, lines 44-47). It would have been obvious to one of ordinary skill in the art at the time of the invention was made to modify the monitor being projecting slightly beyond the adjacent wall surface structure of the car of Amano et al. with the screen of the monitor being substantially flushed with the adjacent wall surface structure of Moore et al. in order to provide a means to compensate for wall thickness or, the availability of space beyond the surface

of the wall. In addition, because these two monitor/wall configurations were art recognized equivalents at the time the invention was made, one of ordinary skill in the art would have found it obvious to substitute a screen of the monitor being substantially flushed with the adjacent wall surface structure for a monitor being projecting slightly beyond the adjacent wall surface structure.

Similarly, the examiner asserts that applying a known technique to a known device ready for improvement would yield predictable results. That is, it would have been recognized by one of ordinary skill in the art that applying the known technique taught by Moore et al. to the subway car of Amano et al. would have yielded predictable results and resulted in an improved system, namely, a screen of the monitor being substantially flushed with the adjacent wall surface structure for a monitor being projecting slightly beyond the adjacent wall surface structure in Amano et al. to provide a means to compensate for wall thickness or, the availability of space beyond the surface of the wall.

Moreover, the examiner asserts that simple substitution of one known element for another would obtain predictable results. That is, the substitution of one known element (a screen of the monitor being substantially flushed with the adjacent wall surface structure as shown in Moore et al.) for another (a monitor being projecting slightly beyond the adjacent wall surface structure as shown in Moore et al. and Amano et al.) would have been obvious to one of ordinary skill in the art at the time of the invention since the substitution of a screen of the monitor being substantially flushed with the adjacent wall surface structure in Amano et al. would have yielded predictable

results, namely, providing a screen of the monitor being substantially flushed with the adjacent wall surface structure in Amano et al. to provide a means to compensate for wall thickness or, the availability of space beyond the surface of the wall.

Furthermore, the examiner asserts use of known technique to improve similar devices in the same way is obvious to one of ordinary skill in the art. That is, the manner of enhancing a particular device (providing a screen of the monitor being substantially flushed with the adjacent wall surface structure) was made part of the ordinary capabilities of one skilled in the art based upon the teaching of such improvement in Moore et al. Accordingly, one of ordinary skill in the art would have been capable of applying this known "improvement" technique in the same manner to the prior art subway car of Amano et al. and the results would have been predictable to one of ordinary skill in the art, namely, one skilled in the art would have readily recognized that providing a screen of the monitor being substantially flushed with the adjacent wall surface structure in Amano et al. would positively provide a means to compensate for wall thickness or, the availability of space beyond the surface of the wall.

Issue 7

13. Claim 1 is rejected under 35 U.S.C. 103(a) as being unpatentable over Maekawa et al. (Japanese. Publication No. JP 04-160991 A) in view of Amano et al. (Japanese. Publication No. JP 02-23985 A) and Moore et al. (U.S. Patent No. 3,480,727).

Maekawa et al. discloses a subway car (car body of an electric train; page 738, column 2; see Figures 1, 2) for mass transportation including longitudinal opposed

Art Unit: 3992

sidewalls (see Figures 1, 2), a ceiling (see Figures 1, 2) adjoining the sidewalls (see Figures 1, 2), a video display system (see Figure 1) comprising a plurality of video display monitors (101-124; page 738, column 2; see Figures 1, 2) each having a video screen (display), and a video signal source unit (see Figure 1) operatively connected to the monitors (101-124; page 738, column 2; see Figures 1, 2), the monitors (101-124; page 738, column 2; see Figures 1, 2) being spaced along the length of the car on opposed sides thereof (see Figures 1, 2), so that each video screen (display) is readily visible to passengers in the subway car (car body of an electric train; page 738, column 2; see Figures 1, 2).

Maekawa et al. discloses all of the limitations of the claimed invention, as previously set forth, except for specifically calling for each of the monitors being mounted at the junction of the sidewall and ceiling and directed obliquely downwardly toward the car seats; and the screen of the monitor being substantially flushed with the adjacent wall surface structure instead of the monitor being projecting slightly beyond the adjacent wall surface structure.

However, each of the monitors being mounted at the junction of the sidewall and ceiling and directed obliquely downwardly toward the car seats is known in the art. Amano et al., for example, teaches each of the monitors being mounted at the junction of the sidewall and ceiling (see Figures 4-6) and directed obliquely downwardly toward the car seats (see Figures 4-6). Amano et al. further teaches such a configuration presents a means to provide the offering place for information in transportation equipment being used more effectively and sharpness being obtained, thereby

Art Unit: 3992

increasing the information offering ability to passengers (English translation Abstract). It would have been obvious to one of ordinary skill in the art at the time of the invention was made to modify the mounting and screen direction orientation of the monitors of Maekawa et al. with each of the monitors being mounted at the junction of the sidewall and ceiling and directed obliquely downwardly toward the car seats of Amano et al. in order to present a means to provide the offering place for information in transportation equipment being used more effectively and sharpness being obtained, thereby increasing the information offering ability to passengers.

Similarly, a screen of the monitor being substantially flushed with the adjacent wall surface structure is known in the art. Moore et al., for example, teach a screen of the monitor being substantially flushed with the adjacent wall surface structure as being an equivalent structure in the art (column 7, lines 41-44). Moore et al. further teaches such a configuration provides a means to compensate for wall thickness or, the availability of space beyond the surface of the wall (column 7, lines 44-47). It would have been obvious to one of ordinary skill in the art at the time of the invention was made to modify the monitor being projecting slightly beyond the adjacent wall surface structure of the car of Maekawa et al. with the screen of the monitor being substantially flushed with the adjacent wall surface structure of Moore et al. in order to provide a means to compensate for wall thickness or, the availability of space beyond the surface of the wall. Furthermore, because these two monitor/wall configurations were art recognized equivalents at the time the invention was made, one of ordinary skill in the art would have found it obvious to substitute a screen of the monitor being substantially

Art Unit: 3992

flushed with the adjacent wall surface structure for a monitor being projecting slightly beyond the adjacent wall surface structure.

Similarly, the examiner asserts that applying a known technique to a known device ready for improvement would yield predictable results. That is, it would have been recognized by one of ordinary skill in the art that applying the known technique taught by Moore et al. to the subway car of Maekawa et al. would have yielded predictable results and resulted in an improved system, namely, a screen of the monitor being substantially flushed with the adjacent wall surface structure for a monitor being projecting slightly beyond the adjacent wall surface structure in Maekawa et al. to provide a means to compensate for wall thickness or, the availability of space beyond the surface of the wall.

Moreover, the examiner asserts that simple substitution of one known element for another would obtain predictable results. That is, the substitution of one known element (a screen of the monitor being substantially flushed with the adjacent wall surface structure as shown in Moore et al.) for another (a monitor being projecting slightly beyond the adjacent wall surface structure as shown in Moore et al. and Maekawa et al.) would have been obvious to one of ordinary skill in the art at the time of the invention since the substitution of a screen of the monitor being substantially flushed with the adjacent wall surface structure in Maekawa et al. would have yielded predictable results, namely, providing a screen of the monitor being substantially flushed with the adjacent wall surface structure in Maekawa et al. to provide a means to

Art Unit: 3992

compensate for wall thickness or, the availability of space beyond the surface of the wall.

Furthermore, the examiner asserts use of known technique to improve similar devices in the same way is obvious to one of ordinary skill in the art. That is, the manner of enhancing a particular device (providing a screen of the monitor being substantially flushed with the adjacent wall surface structure) was made part of the ordinary capabilities of one skilled in the art based upon the teaching of such improvement in Moore et al. Accordingly, one of ordinary skill in the art would have been capable of applying this known "improvement" technique in the same manner to the prior art subway car of Maekawa et al. and the results would have been predictable to one of ordinary skill in the art, namely, one skilled in the art would have readily recognized that providing a screen of the monitor being substantially flushed with the adjacent wall surface structure in Maekawa et al. would positively provide a means to compensate for wall thickness or, the availability of space beyond the surface of the wall.

Issue 8

14. Claim 1 is rejected under 35 U.S.C. 103(a) as being unpatentable over Shinagawa et al. (Japanese. Publication No. JP 04-160991 A) in view of Amano et al. (Japanese. Publication No. JP 02-23985 A) and Moore et al. (U.S. Patent No. 3,480,727).

Shinagawa et al. discloses a subway car (car of a train; page 619, column 1; see Figure 4) for mass transportation including longitudinal opposed sidewalls (see Figure

Art Unit: 3992

4), a ceiling (see Figure 4) adjoining the sidewalls (see Figure 4), a video display system (see Figure 1) comprising a plurality of video display monitors (21-2n; page 621, column 1; see Figures 1, 4) each having a video screen (display), and a video signal source unit (see Figure 1) operatively connected to the monitors (21-2n; page 621, column 1; see Figures 1, 4), the monitors (21-2n; page 621, column 1; see Figures 1, 4) being spaced along the length of the car on opposed sides thereof (page 621, column 1, paragraph 3; see Figures 1, 4), so that each video screen (display) is readily visible to passengers in the subway car (car of a train; page 619, column 1; see Figure 4).

Shinagawa et al. discloses all of the limitations of the claimed invention, as previously set forth, except for specifically calling for each of the monitors being mounted at the junction of the sidewall and ceiling and directed obliquely downwardly toward the car seats; and the screen of the monitor being substantially flushed with the adjacent wall surface structure instead of the monitor being projecting slightly beyond the adjacent wall surface structure.

However, each of the monitors being mounted at the junction of the sidewall and ceiling and directed obliquely downwardly toward the car seats is known in the art. Amano et al., for example, teaches each of the monitors being mounted at the junction of the sidewall and ceiling (see Figures 4-6) and directed obliquely downwardly toward the car seats (see Figures 4-6). Amano et al. further teaches such a configuration presents a means to provide the offering place for information in transportation equipment being used more effectively and sharpness being obtained, thereby increasing the information offering ability to passengers (English translation Abstract). It

Art Unit: 3992

would have been obvious to one of ordinary skill in the art at the time of the invention was made to modify the mounting and screen direction orientation of the monitors of Shinagawa et al. with each of the monitors being mounted at the junction of the sidewall and ceiling and directed obliquely downwardly toward the car seats of Amano et al. in order to present a means to provide the offering place for information in transportation equipment being used more effectively and sharpness being obtained, thereby increasing the information offering ability to passengers.

Similarly, a screen of the monitor being substantially flushed with the adjacent wall surface structure is known in the art. Moore et al. for example, teach a screen of the monitor being substantially flushed with the adjacent wall surface structure as being an equivalent structure in the art (column 7, lines 41-44). Moore et al. further teaches such a configuration provides a means to compensate for wall thickness or, the availability of space beyond the surface of the wall (column 7, lines 44-47). It would have been obvious to one of ordinary skill in the art at the time of the invention was made to modify the monitor being projecting slightly beyond the adjacent wall surface structure of the car of Shinagawa et al. with the screen of the monitor being substantially flushed with the adjacent wall surface structure of Moore et al. in order to provide a means to compensate for wall thickness or, the availability of space beyond the surface of the wall. Furthermore, because these two monitor/wall configurations were art recognized equivalents at the time the invention was made, one of ordinary skill in the art would have found it obvious to substitute a screen of the monitor being

Art Unit: 3992

substantially flushed with the adjacent wall surface structure for a monitor being projecting slightly beyond the adjacent wall surface structure.

Similarly, the examiner asserts that applying a known technique to a known device ready for improvement would yield predictable results. That is, it would have been recognized by one of ordinary skill in the art that applying the known technique taught by Moore et al. to the subway car of Shinagawa et al. would have yielded predictable results and resulted in an improved system, namely, a screen of the monitor being substantially flushed with the adjacent wall surface structure for a monitor being projecting slightly beyond the adjacent wall surface structure in Shinagawa et al. to provide a means to compensate for wall thickness or, the availability of space beyond the surface of the wall.

Moreover, the examiner asserts that simple substitution of one known element for another would obtain predictable results. That is, the substitution of one known element (a screen of the monitor being substantially flushed with the adjacent wall surface structure as shown in Moore et al.) for another (a monitor being projecting slightly beyond the adjacent wall surface structure as shown in Moore et al. and Shinagawa et al.) would have been obvious to one of ordinary skill in the art at the time of the invention since the substitution of a screen of the monitor being substantially flushed with the adjacent wall surface structure in Shinagawa et al. would have yielded predictable results, namely, providing a screen of the monitor being substantially flushed with the adjacent wall surface structure in Shinagawa et al. to provide a means

Art Unit: 3992

to compensate for wall thickness or, the availability of space beyond the surface of the wall.

Furthermore, the examiner asserts use of known technique to improve similar devices in the same way is obvious to one of ordinary skill in the art. That is, the manner of enhancing a particular device (providing a screen of the monitor being substantially flushed with the adjacent wall surface structure) was made part of the ordinary capabilities of one skilled in the art based upon the teaching of such improvement in Moore et al. Accordingly, one of ordinary skill in the art would have been capable of applying this known "improvement" technique in the same manner to the prior art subway car of Amano et al. and the results would have been predictable to one of ordinary skill in the art, namely, one skilled in the art would have readily recognized that providing a screen of the monitor being substantially flushed with the adjacent wall surface structure in Shinagawa et al. would positively provide a means to compensate for wall thickness or, the availability of space beyond the surface of the wall.

Art Unit: 3992

Conclusion

Extensions of time under 37 CFR 1.136(a) will not be permitted in these proceedings because the provisions of 37 CFR 1.136 apply only to "an applicant" and not to parties in a reexamination proceeding. Additionally, 35 U.S.C. 305 requires that reexamination proceedings "will be conducted with special dispatch" (37 CFR 1.550(a)). Extension of time in *ex parte* reexamination proceedings are provided for in 37 CFR 1.550(c).

The patent owner is reminded of the continuing responsibility under 37 CFR 1.565(a), to apprise the Office of any litigation activity, or other prior or concurrent proceeding, involving Patent No. 6,700,602 throughout the course of this reexamination proceeding. See MPEP §§ 2207, 2282 and 2286.

All correspondence relating to this *ex parte* reexamination proceeding should be directed:

By Mail to: Mail Stop *Ex Parte* Reexam
Central Reexamination Unit
Commissioner for Patents
United States Patent & Trademark Office
P.O. Box 1450
Alexandria, VA 22313-1450

By FAX to: (571) 273-9900
Central Reexamination Unit

By hand: Customer Service Window
Randolph Building
401 Dulany Street
Alexandria, VA 22314

By EFS-Web:

Art Unit: 3992

Registered users of EFS-Web may alternatively submit such correspondence via the electronic filing system EFS-Web, at

<https://efs.uspto.gov/efile/myportal/efs-registered>

EFS-Web offers the benefit of quick submission to the particular area of the Office that needs to act on the correspondence. Also, EFS-Web submissions are "soft scanned" (i.e., electronically uploaded) directly into the official file for the reexamination proceeding, which offers parties the opportunity to review the content of their submissions after the "soft scanning" process is complete.

Any inquiry concerning this communication or earlier communications from the Reexamination Legal Advisor or Examiner, or as to the status of this proceeding, should be directed to the Central Reexamination Unit at telephone number (571) 272-7705.

/Stephen J Ralis/
Primary Examiner, Art Unit 3992

Conferee

SUDHANSHU C. PATHAK
SPRS, 39.92

Conferee

Notice of References Cited	Application/Control No. 90/011,861	Applicant(s)/Patent Under Reexamination 6700602	
	Examiner STEPHEN RALIS	Art Unit 3992	Page 1 of 1

U.S. PATENT DOCUMENTS

*	Document Number Country Code-Number-Kind Code	Date MM-YYYY	Name	Classification
*	A US-3,480,727	11-1969	MOORE CHESTER W et al.	348/156
B	US-			
C	US-			
D	US-			
E	US-			
F	US-			
G	US-			
H	US-			
I	US-			
J	US-			
K	US-			
L	US-			
M	US-			

FOREIGN PATENT DOCUMENTS

*	Document Number Country Code-Number-Kind Code	Date MM-YYYY	Country	Name	Classification
N					
O					
P					
Q					
R					
S					
T					

NON-PATENT DOCUMENTS

*	Include as applicable: Author, Title Date, Publisher, Edition or Volume, Pertinent Pages)
U	
V	
W	
X	

*A copy of this reference is not being furnished with this Office action. (See MPEP § 707.05(a).)
Dates in MM-YYYY format are publication dates. Classifications may be US or foreign.

Search Notes 	Application/Control No. 90011861	Applicant(s)/Patent Under Reexamination 6700602
	Examiner STEPHEN RALIS	Art Unit 3992

SEARCHED			
Class	Subclass	Date	Examiner

SEARCH NOTES		
Search Notes	Date	Examiner
Reviewed proposed prior art and patent prosecution history.	9/23/2011	SR
Text Searching Strategies (see EAST notes)	9/26/2011	SR
Reviewed proposed prior art and patent prosecution history.	12/23/2011	SR

INTERFERENCE SEARCH			
Class	Subclass	Date	Examiner

--	--

EAST Search History

EAST Search History (Prior Art)

Ref #	Hits	Search Query	DBs	Default Operator	Plurals	Time Stamp
S1	0	"63125984"	USPAT	OR	OFF	2011/09/26 10:07
S2	0	"63125984"	JPO; DERWENT	OR	OFF	2011/09/26 10:07
S3	0	"63125984"	EPO; JPO; DERWENT	OR	OFF	2011/09/26 10:07
S4	0	"630125984"	EPO; JPO; DERWENT	OR	OFF	2011/09/26 10:08
S5	0	"63125984"	US-PGPUB; USPAT; EPO; JPO; DERWENT	OR	OFF	2011/09/26 10:08
S6	60	"223985"	US-PGPUB; USPAT; EPO; JPO; DERWENT	OR	OFF	2011/09/26 10:14
S7	0	"90223985"	US-PGPUB; USPAT; EPO; JPO; DERWENT	OR	OFF	2011/09/26 10:16
S8	0	"90223985"	EPO; JPO; DERWENT	OR	OFF	2011/09/26 10:16
S9	41	"223985"	EPO; JPO; DERWENT	OR	OFF	2011/09/26 10:16
S10	0	"63125984"	EPO; JPO; DERWENT	OR	OFF	2011/09/26 12:19
S11	0	("63125984").PN.	USPAT; USOCR	OR	OFF	2011/09/26 12:20
S12	0	"61285490"	USPAT	OR	OFF	2011/09/26 12:20
S13	0	"61285490"	US-PGPUB; USPAT; USOCR; EPO; JPO; DERWENT	OR	OFF	2011/09/26 12:20
S14	0	"63125984"	EPO; JPO; DERWENT	OR	OFF	2011/09/26 12:22
S15	2	"04160991"	EPO; JPO; DERWENT	OR	OFF	2011/09/26 13:55
S16	1	"02223985"	EPO; JPO; DERWENT	OR	OFF	2011/09/26 13:56
S17	0	"61285940"	EPO; JPO; DERWENT	OR	OFF	2011/09/26 13:57
S18	23	(display or screen) with (top or ceiling) with (side or wall) with (flush or coplanar)	EPO; JPO; DERWENT	OR	OFF	2011/09/26 15:51
S19	403	(display or screen) with (top or ceiling) with (side or wall) with (flush or coplanar)	US-PGPUB; USPAT; USOCR; EPO; JPO; DERWENT	OR	OFF	2011/09/26 15:52
S20	1125728	train or rail	US-PGPUB; USPAT; USOCR; EPO; JPO;	OR	OFF	2011/09/26 15:52

EAST Search History

			DERWENT			
S21	48	S19 and S20	US-PGPUB; USPAT; USOCR; EPO; JPO; DERWENT	OR	OFF	2011/09/26 15:52
S22	325	S19 not window	US-PGPUB; USPAT; USOCR; EPO; JPO; DERWENT	OR	OFF	2011/09/26 15:58
S23	288	S22 not S21	US-PGPUB; USPAT; USOCR; EPO; JPO; DERWENT	OR	OFF	2011/09/26 15:58
S24	15	(monitor) with (top or ceiling) with (side or wall) with (flush or coplanar)	US-PGPUB; USPAT; USOCR; EPO; JPO; DERWENT	OR	OFF	2011/09/26 16:19
S25	31	(monitor) with (mount\$3) with (side or wall) with (flush or coplanar)	US-PGPUB; USPAT; USOCR; EPO; JPO; DERWENT	OR	OFF	2011/09/26 16:25

12/23/2011 1:28:47 PM

C:\Users\sralis\Documents\EAST\Workspaces\90011861.wsp



UNITED STATES PATENT AND TRADEMARK OFFICE

UNITED STATES DEPARTMENT OF COMMERCE
 United States Patent and Trademark Office
 Address: COMMISSIONER FOR PATENTS
 P.O. Box 1450
 Alexandria, Virginia 22313-1450
 www.uspto.gov

BIB DATA SHEET

CONFIRMATION NO. 3736

SERIAL NUMBER 90/011,861	FILING or 371(c) DATE 08/16/2011 RULE	CLASS 348	GROUP ART UNIT 3992	ATTORNEY DOCKET NO. BLAIR.001A	
APPLICANTS 6700602, Residence Not Provided; SCOTT BLAIR, TORONTO, CANADA; PETER J. GUTIERREZ III, SAN DIEGO, CA;					
** CONTINUING DATA ***** This application is a REX of 09/423,284 02/22/2000 PAT 6,700,602 which is a 371 of PCT/CA98/00439 05/06/1998 which claims benefit of 60/045,811 05/07/1997					
** FOREIGN APPLICATIONS *****					
** IF REQUIRED, FOREIGN FILING LICENSE GRANTED **					
Foreign Priority claimed <input type="checkbox"/> Yes <input checked="" type="checkbox"/> No 35 USC 119(a-d) conditions met <input type="checkbox"/> Yes <input checked="" type="checkbox"/> No Verified and Acknowledged <u>/STEPHEN J RALIS/</u> Examiner's Signature	<input type="checkbox"/> Met after Allowance Initials	STATE OR COUNTRY	SHEETS DRAWINGS	TOTAL CLAIMS 7	INDEPENDENT CLAIMS 1
ADDRESS GAZDZINSKI & ASSOCIATES, PC 16644 WEST BERNARDO DRIVE SUITE 201 SAN DIEGO, CA 92127 UNITED STATES					
TITLE SUBWAY TV MEDIA SYSTEM					
FILING FEE RECEIVED 2520	FEES: Authority has been given in Paper No. _____ to charge/credit DEPOSIT ACCOUNT No. _____ for following:		<input type="checkbox"/> All Fees <input type="checkbox"/> 1.16 Fees (Filing) <input type="checkbox"/> 1.17 Fees (Processing Ext. of time) <input type="checkbox"/> 1.18 Fees (Issue) <input type="checkbox"/> Other _____ <input type="checkbox"/> Credit		

Reexamination 	Application/Control No. 90011861	Applicant(s)/Patent Under Reexamination 6700602
	Certificate Date	Certificate Number

Requester Correspondence Address:	<input checked="" type="checkbox"/> Patent Owner	<input type="checkbox"/> Third Party
<p>GAZDZINSKI & ASSOCIATES, PC 16644 WEST BERNARDO DRIVE SUITE 201 SAN DIEGO, CA 92127</p>		

LITIGATION REVIEW <input checked="" type="checkbox"/>	SR (examiner initials)	09/27/2011 (date)
Case Name		Director Initials
No Litigation is currently pending.		<i>for 17</i>

COPENDING OFFICE PROCEEDINGS	
TYPE OF PROCEEDING	NUMBER
1. No copending proceedings.-	

--	--

IN THE UNITED STATES PATENT AND TRADEMARK OFFICE

Patentee : Scott Blair)
 Patent No. : 6,700,602 – Issued 03/02/04)
 Control No. : 90/011,861)
 Filed : August 16, 2011)
 For : **SUBWAY TV MEDIA SYSTEM**)
 Examiner : Stephen Ralis)
 Group Art Unit: 3992)



27299
PATENT TRADEMARK OFFICE

CERTIFICATE OF ELECTRONIC (EFS-WEB) TRANSMISSION

I hereby certify that this correspondence is being transmitted via the Office electronic filing system in accordance with 37 C.F.R. § 1.8(a)(1)(C) from the Pacific Time Zone of the United States on the local date shown below.

Dated: March 9, 2012

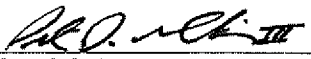
By: 
Peter J. Gutierrez, III, Reg. No. 56,732

TRANSMITTAL LETTER – EX PARTE REEXAMINATION

Mail Stop *Ex Parte* Reexam
Central Reexamination Unit
Commissioner for Patents
United States Patent & Trademark Office
P.O. Box 1450
Alexandria, VA 22313-1450

Sir:

Transmitted herewith in the above-entitled Ex Parte Reexamination application are the following:

1. Response to Office Action – Ex Parte Reexamination (19 Pages).

Control No. : 90/011,861
Filed : August 16, 2011

The fee has been calculated as shown below:

EX PARTE REEXAMINATION CLAIMS AS FILED							
	CLAIMS REMAINING AFTER RESPONSE		HIGHEST NO. PREVIOUSLY PAID FOR	PRESENT EXTRA	RATE		ADDITIONAL FEE
Total Claims	30	MINUS	20	= 10 X	\$ 30		= \$300
Independent Claims	4	MINUS	3	= 1 X	\$125		= \$125
TOTAL ADDITIONAL FEE FOR THIS APPLICATION							\$425

The Commissioner is hereby authorized to charge any fees which may be required to Deposit Account No. 501423.

Respectfully submitted,

GAZDZINSKI & ASSOCIATES, PC

Dated: March 9, 2012

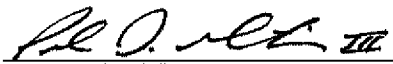
By: 
Peter J. Gutierrez, III
Registration No. 56,732
16644 West Bernardo Drive, Suite 201
San Diego, CA 92127
Telephone No.: (858) 675-1670
Facsimile No.: (858) 675-1674

Electronic Patent Application Fee Transmittal

Application Number:	90011861
Filing Date:	16-Aug-2011
Title of Invention:	SUBWAY TV MEDIA SYSTEM
First Named Inventor/Applicant Name:	6700602
Filer:	Robert F. Gazdzinski/Rebecca Beach
Attorney Docket Number:	BLAIR.001A

Filed as Small Entity

ex parte reexam Filing Fees

Description	Fee Code	Quantity	Amount	Sub-Total in USD(\$)
Basic Filing:				
Pages:				
Claims:				
Reexamination Independent Claims	2821	1	125	125
Reexamination claims in excess of 20	2822	10	30	300

Miscellaneous-Filing:

Petition:

Patent-Appeals-and-Interference:

Post-Allowance-and-Post-Issuance:

Description	Fee Code	Quantity	Amount	Sub-Total in USD(\$)
Extension-of-Time:				
Miscellaneous:				
Total in USD (\$)				425

Electronic Acknowledgement Receipt

EFS ID:	12273592
Application Number:	90011861
International Application Number:	
Confirmation Number:	3736
Title of Invention:	SUBWAY TV MEDIA SYSTEM
First Named Inventor/Applicant Name:	6700602
Customer Number:	27299
Filer:	Robert F. Gazdzinski/Rebecca Beach
Filer Authorized By:	Robert F. Gazdzinski
Attorney Docket Number:	BLAIR.001A
Receipt Date:	09-MAR-2012
Filing Date:	16-AUG-2011
Time Stamp:	19:26:26
Application Type:	Reexam (Patent Owner)

Payment information:

Submitted with Payment	yes
Payment Type	Deposit Account
Payment was successfully received in RAM	\$425
RAM confirmation Number	6556
Deposit Account	501423
Authorized User	

The Director of the USPTO is hereby authorized to charge indicated fees and credit any overpayment as follows:

Charge any Additional Fees required under 37 C.F.R. Section 1.16 (National application filing, search, and examination fees)

Charge any Additional Fees required under 37 C.F.R. Section 1.17 (Patent application and reexamination processing fees)

Charge any Additional Fees required under 37 C.F.R. Section 1.19 (Document supply fees)

Charge any Additional Fees required under 37 C.F.R. Section 1.20 (Post Issuance fees)

Charge any Additional Fees required under 37 C.F.R. Section 1.21 (Miscellaneous fees and charges)

File Listing:

Document Number	Document Description	File Name	File Size(Bytes)/ Message Digest	Multi Part /.zip	Pages (if appl.)
1	Applicant Arguments/Remarks Made in an Amendment	Response.pdf	776603 b653d88333edad7602fbdad274b6aa0ef2a6a7b2	no	19

Warnings:

Information:

2	Transmittal Letter	Transmittal.pdf	42684 335c22cec1a5d322e767175b5b5e8f043264e28	no	2
---	--------------------	-----------------	--	----	---

Warnings:

Information:

3	Fee Worksheet (SB06)	fee-info.pdf	31789 00175ea24b675812012cccfbfe801c1a1d63cd73	no	2
---	----------------------	--------------	---	----	---

Warnings:

Information:

Total Files Size (in bytes):

851076

This Acknowledgement Receipt evidences receipt on the noted date by the USPTO of the indicated documents, characterized by the applicant, and including page counts, where applicable. It serves as evidence of receipt similar to a Post Card, as described in MPEP 503.

New Applications Under 35 U.S.C. 111

If a new application is being filed and the application includes the necessary components for a filing date (see 37 CFR 1.53(b)-(d) and MPEP 506), a Filing Receipt (37 CFR 1.54) will be issued in due course and the date shown on this Acknowledgement Receipt will establish the filing date of the application.

National Stage of an International Application under 35 U.S.C. 371

If a timely submission to enter the national stage of an international application is compliant with the conditions of 35 U.S.C. 371 and other applicable requirements a Form PCT/DO/EO/903 indicating acceptance of the application as a national stage submission under 35 U.S.C. 371 will be issued in addition to the Filing Receipt, in due course.

New International Application Filed with the USPTO as a Receiving Office

If a new international application is being filed and the international application includes the necessary components for an international filing date (see PCT Article 11 and MPEP 1810), a Notification of the International Application Number and of the International Filing Date (Form PCT/RO/105) will be issued in due course, subject to prescriptions concerning national security, and the date shown on this Acknowledgement Receipt will establish the international filing date of the application.

IN THE UNITED STATES PATENT AND TRADEMARK OFFICE

Patentee : Scott Blair)
 Patent No. : 6,700,602 – Issued 03/02/04)
 Control No. : 90/011,861)
 Filed : August 16, 2011)
 For : **SUBWAY TV MEDIA SYSTEM**)
 Examiner : Stephen Ralis)
 Group Art Unit: 3992)



27299

PATENT TRADEMARK OFFICE

CERTIFICATE OF ELECTRONIC (EFS-WEB) TRANSMISSION

I hereby certify that this correspondence is being transmitted via the Office electronic filing system in accordance with 37 C.F.R. § 1.8(a)(i)(C) from the Pacific Time Zone of the United States on the local date shown below.

Dated: March 9, 2012

By: Peter J. Gutierrez, III
Peter J. Gutierrez, III, Reg. No. 56,732

5

RESPONSE TO OFFICE ACTION – EX PARTE REEXAMINATION

10 Mail Stop *Ex Parte* Reexam
Central Reexamination Unit
Commissioner for Patents
P.O. Box 1450
Alexandria, VA 22313-1450

15

Dear Sir:

In response to the Office Action in *Ex Parte* Reexamination dated January 11, 2012 (“*Ex Parte* Office Action”), the following is provided:

20

Control No. : 90/011,861
Filed : August 16, 2011

IN THE CLAIMS

United States Patent No. 6,700,602 (hereinafter "the '602 Patent") issued with Claims 1 – 7. By this paper, Claims 1 – 7 are set forth herein in their original state. New Claims 8 – 30 are being added. Accordingly, Claims 1 – 30 are presented as follows:

1. A subway car for mass transportation including longitudinal opposed sidewalls, a ceiling adjoining the sidewalls, a video display system comprising a plurality of video display monitors each having a video screen, and a video signal source unit operatively connected to said monitors,

said monitors being spaced along the length of the car on opposed sides thereof, each of said monitor being mounted at the junction of the sidewall and ceiling, with the screen of the monitor substantially flushed with the adjacent wall surface structure of the car, and directed obliquely downwardly toward the car seats, so that each video screen is readily visible to passengers in the subway car.

2. The subway car of claim 1 wherein the video signal source system includes a pre-recorded video transmission program for feeding to display on the monitors of duration about 5-15 minutes.

3. The subway car of claim 1 wherein the program is repeatable, and includes a series of commercial messages of 30 second-1 minute duration.

4. The video system subway car of claim 1 which is sound free.

5. The subway car of claim 1 wherein the video signal source unit comprises a video tape player, a video disk player or computer-based digital video recorder.

6. The subway car of claim 1 wherein the video monitors include LCD screens.

7. The subway car of any of claim 1 including a self-contained wiring-cabling system connecting the video monitors to the video signal source unit.

8. A subway car for mass transportation, comprising:
a video display system comprising a plurality of video display monitors each having a video screen, and a video signal source unit operatively connected to said video display monitors;

Control No. : 90/011,861
Filed : August 16, 2011

a pair of longitudinal opposed sidewalls, each of the sidewalls comprising a transitional wall portion at the junction of the sidewall and ceiling that is directed obliquely downwardly;
and

a ceiling adjoining the sidewalls;

5 wherein the monitors are spaced along the length of the car on opposed sides thereof, the monitors being disposed within the transitional wall portion such that the video screen of the respective video display monitor substantially blends with the adjacent surface structure of the transitional wall portion and is also directed obliquely downwardly toward the car seats so that each video screen is readily visible to passengers in the subway car.

10 9. The subway car of Claim 8, wherein the video screen of the video display monitor comprises a rigid transparent unit configured to protect the video display monitor.

10. The subway car of Claim 9, wherein the video display monitor is disposed within the transitional wall portion such that it contains no visible edges or protuberances.

15 11. The subway car of Claim 8, further comprising a back lit panel disposed on the transitional wall portion, the back lit panel disposed adjacent the video screen of the video display monitor.

12. The subway car of Claim 8, wherein the video display monitors are each enclosed within an enclosure.

20 13. The subway car of Claim 12, wherein the enclosure is secured to a structural member disposed between an inner wall and an outer structural shell of the subway car.

14. The subway car of Claim 13, wherein the enclosure and a respective video display monitor is removable from the subway car as a unit.

25 15. A subway car for mass transportation including longitudinal opposed sidewalls that further comprise a transitional segment and a ceiling adjoining the sidewalls with the transitional segment disposed at the junction of the sidewall and the ceiling, the subway car further comprising:

a video display system comprising:

a plurality of video display monitors each having a video screen; and

a video signal source unit operatively connected to said video display monitors;

Control No. : 90/011,861
Filed : August 16, 2011

5 wherein said video display monitors are spaced along the length of the car on opposing sides of the subway, each of the video display monitors being mounted within the transitional segment, with the video screen of each video display monitor being substantially contiguous with an exterior surface of said transitional segment, said video screen being directed obliquely downwardly toward the car seats so that each video screen is readily visible to passengers in the subway car.

16. The subway car of Claim 15, wherein an external surface of the longitudinal opposed sidewall, the exterior surface of said transitional segment and an external surface of the ceiling comprise a blended contour.

10 17. The subway car of Claim 15, wherein the video signal source unit is configured to display a series of short messages in sequence on said plurality of video display monitors.

18. The subway car of Claim 17, wherein the series of short messages comprise advertising content, said advertising content providing an additional source of revenue for the operator of the subway car.

15 19. The subway car of Claim 18, further comprising a back lit panel disposed on the transitional segment disposed adjacent the ceiling and a respective sidewall.

20 20. The subway car of Claim 19, wherein the back lit panel is disposed adjacent the video screen of the video display monitor.

21. A subway car for mass transportation including longitudinal opposed sidewalls, a ceiling adjoining the sidewalls, a video display system comprising a plurality of video display monitors each having a video screen, and a video signal source unit operatively connected to said monitors,

25 said monitors being spaced along the length of the car on opposed sides thereof, each of said monitors being mounted at the junction of the sidewall and ceiling, with the screen of the monitor flushed with the adjacent wall surface structure of the car, and directed obliquely downwardly toward the car seats, so that each video screen is readily visible to passengers in the subway car.

22. The subway car of Claim 21, wherein the display portion of the video display monitor comprises a rigid transparent unit configured to protect the video display monitor.

Control No. : 90/011,861
Filed : August 16, 2011

23. The subway car of Claim 21, wherein the video display monitor is flushed within the adjacent wall structure such that it contains no protuberances.

24. The subway car of Claim 21, further comprising a back lit panel disposed on the adjacent wall surface structure of the car.

5 25. The subway car of Claim 21, wherein the video display monitors are each enclosed within an enclosure.

26. The subway car of Claim 25, wherein the enclosure is secured to a structural member disposed between an inner wall and an outer structural shell of the subway car.

10 27. The subway car of Claim 26, wherein the enclosure and a respective video display monitor is removable from the subway car as a unit.

28. The subway car of Claim 21, wherein an external surface of the longitudinal opposed sidewalls, the adjacent wall surface structure and an external surface of the ceiling comprise a blended contour.

15 29. The subway car of Claim 21, wherein the video signal source unit is configured to display a series of short messages in sequence on said plurality of video display monitors.

30. The subway car of Claim 29, wherein the series of short messages comprise advertising content, said advertising content providing an additional source of revenue for the operator of the subway car.

20

Control No. : 90/011,861
Filed : August 16, 2011

REMARKS

The '602 Patent issued with Claims 1 – 7. By this paper, Claim 1 is set forth herein in its original state. New Claims 8 – 30 are being added herein. Accordingly, Claims 1 – 30 are presented for examination herein.

35 U.S.C. §102

1. Per page 4 of the Office Action, Claim 1 stands rejected under 35 U.S.C. §102 as being anticipated by Minesaki (Japanese Publication No. JP 63-125984, hereinafter “Minesaki”).

In response thereto, Patent Owner provides the following remarks:

Claim 1 – Patent Owner respectfully submits that it is well established that “[a] claim is anticipated only if each and every element as set forth in the claim is found, either expressly or inherently described, in a single prior art reference.” Verdegaal Bros. v. Union Oil Co. of California, 814 F.2d 628, 631, 2 USPQ2d 1051, 1053 (Fed. Cir. 1987). See also MPEP §2131.

With regards to the Office’s rejection of Claim 1 as being anticipated by Minesaki, Patent Owner respectfully traverses. Specifically, Minesaki fails to expressly or inherently describe: (1) “each of said monitor being mounted at the junction of the sidewall and ceiling”; (2) “with the screen of the monitor substantially flushed with the adjacent wall surface structure of the car”; and (3) “directed obliquely downwardly toward the car seats”.

With regards to the claimed feature “each of said monitor being mounted at the junction of the sidewall and ceiling”, Minesaki appears to only contemplate two configurations for mounting the information transmission display (part J). Specifically, one such configuration contemplated by Minesaki is an “*information display part J ... which is suspended and hangs down from the ceiling*”. {emphasis added} Such a configuration as described does not expressly or inherently describe mounting the monitor at the junction of the sidewall and ceiling.

Minesaki’s second configuration contemplates that the “*information transmission display part J may also be formed on the sidewall 9 of the train car.*” {emphasis added} Accordingly, Minesaki only appears to contemplate suspending the information transmission display part from the ceiling, or alternatively, forming the information transmission display part on the sidewall of

Control No. : 90/011,861
Filed : August 16, 2011

the train car, and respectfully does *not* contemplate mounting the monitor at the junction of the sidewall and ceiling.

Furthermore, with regards to the claimed feature “with the screen of the monitor substantially flushed with the adjacent wall surface structure of the car”, the Office alleges that the term “substantially” is often used in conjunction with another term to describe a particular characteristic of the claimed invention and is further construed to be a broad term (citing MPEP §2173.05). While Patent Owner agrees that the term “substantially” is construed broadly, the use of the term “substantially” cannot be construed so broadly as to read the term “flushed” completely out of the claim. See e.g., *Exxon Chem. Patents v. Lubrizol Corp.*, 64 F.3d 1553, 1555 (Fed. Cir. 1995), *cert. denied*, 518 U.S. 1020 (1996), as it believes the Office’s interpretation has done.

Furthermore, Patent Owner notes that terms in its claims must be interpreted in light of Patent Owner’s specification as filed; see MPEP 2111; “the pending claims must be “given their broadest reasonable interpretation consistent with the specification.” *Phillips v. AWH Corp.*, 415 F.3d 1303, 75 USPQ2d 1321 (Fed. Cir. 2005)” {emphasis added}. Figure 2 of Minesaki is reproduced below for the convenience of the Office.

Fig. 2

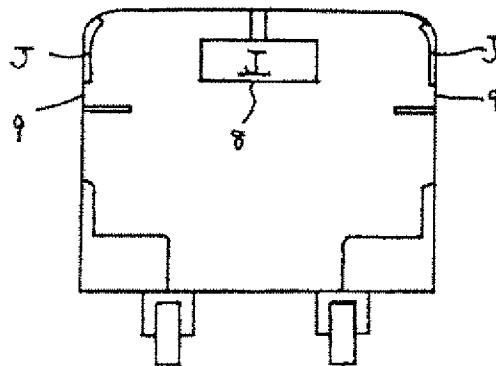
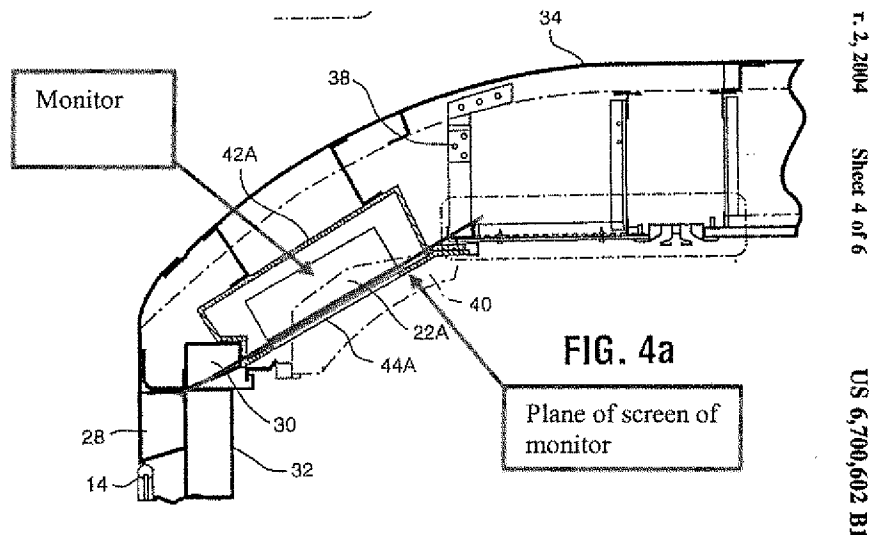

Figure 2 of Minesaki

As can be seen, there is not a single part of the information transmission display (part J) illustrated in Figure 2 which can reasonably be considered to be flush with the adjacent wall surface (as Patent Owner has used that term in its specification and Claim 1); in fact, the entire information

transmission display part J of Minesaki clearly protrudes away from the adjacent wall surface. Patent Owner refers the Office to FIG. 4a of its specification (reproduced below for convenience), which clearly shows an embodiment of Patent Owner's invention that has a screen that is substantially flushed with the adjacent wall surface (as explicitly recited in Claim 1), and with no protrusion of the display (as occurs in Minesaki). As indicated in Patent Owner's specification regarding FIG. 4a, this configuration gives a better aesthetic appearance to the inside of the subway car as a whole, as well as improving the display performance by minimizing the interference effects.



10

Accordingly, Patent Owner respectfully submits that the Office's interpretation of the term "substantially flushed" is improper, as the Office's interpretation completely reads out the "flushed" feature.

Finally, Patent Owner respectfully submits that Minesaki does not expressly or inherently describe that "the screen of the monitor ... [is] directed obliquely downwardly toward the car seats". While Patent Owner admits that the information transmission display parts J of Minesaki appear curved with the top portion seemingly directed obliquely downwardly, the majority portion of the information transmission display part J is directed perpendicular to the sidewall of the Minesaki train (see Fig. 2 reproduced above). Furthermore, Patent Owner has set forth and claimed

20

in Claim 1 that “the screen of the monitor ... [is] directed obliquely downwardly toward the car seats” as opposed to setting forth and claiming that only portions of the screen of the monitor are directed obliquely downwardly. Accordingly, Patent Owner submits that Claim 1 distinguishes on this independent and distinct basis as well.

5

2. Per page 6 of the Office Action, Claim 1 stands rejected under 35 U.S.C. §102 as being anticipated by Amano et al. (Japanese Publication No. JP 02-23985 A, hereinafter “Amano”). In response thereto, Patent Owner provides the following remarks:

10 **Claim 1** – With regards to the Office’s rejection of Claim 1 as being anticipated by Amano, Patent Owner respectfully traverses. Specifically, Patent Owner respectfully submits that Amano fails to expressly or inherently describe “the screen of the monitor substantially flushed with the adjacent wall surface structure of the car”.

15 Again, the Office alleges that the term “substantially” is often used in conjunction with another term to describe a particular characteristic of the claimed invention and is further construed to be a broad term (citing MPEP §2173.05). Again, Patent Owner respectfully submits that the use of the term “substantially” cannot be construed so broadly as to read the term “flushed” completely out of the claim. Figures 4 – 6 of Amano are reproduced below for the convenience of the Office.

Figure 4

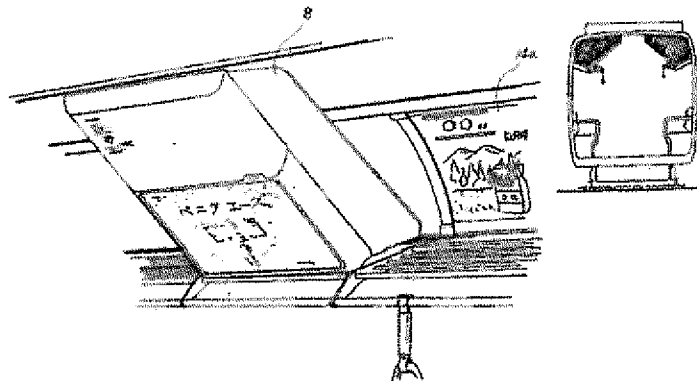

20

Figure 4 of Amano

Figure 5

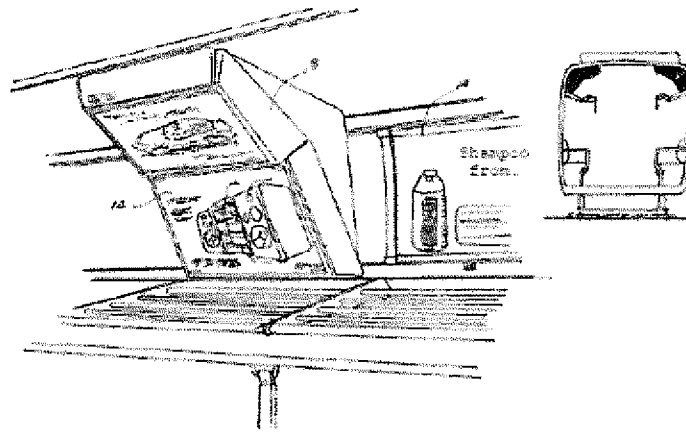

Figure 5 of Amano

Figure 6

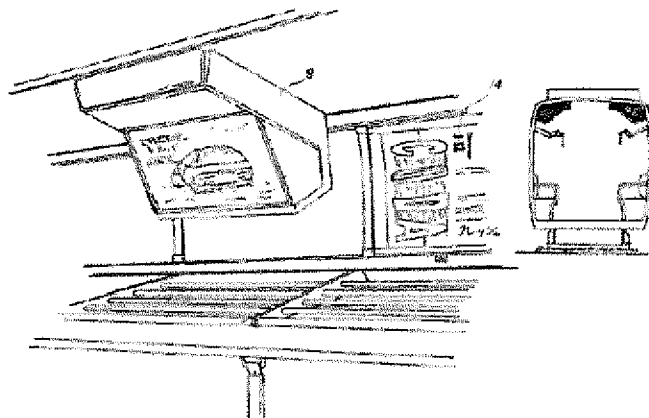

Figure 6 of Amano

5

As can be seen, there is not a single part of the information display device 8 illustrated in Figures 4 – 6 that can reasonably be considered to be “flush with the adjacent wall surface” as recited in Claim 1. In fact, the entire information display device 8 of Amano (including the screen, which is the component Patent Owner’s Claim 1 recites as being substantially flushed with the wall surface) clearly protrudes from the adjacent wall surface. Patent Owner respectfully submits that the Office’s interpretation of the term “substantially flushed” is improper, as the Office’s interpretation completely reads out the “flushed” feature. See again FIG. 4a of the ‘602 Patent discussed *supra*.

10

Accordingly, Patent Owner respectfully submits that the Office’s rejection of Claim 1 as being anticipated by Amano is improper, and should be withdrawn.

35 U.S.C. §103

3. Per page 7 of the Office Action, Claim 1 stands rejected under 35 U.S.C. §103 as being unpatentable over Maekawa (Japanese Publication No. JP 04-160991 A, hereinafter “Maekawa”) in view of Amano. In response thereto, Patent Owner provides the following remarks:

Claim 1 – With regards to Claim 1, the Office admits that Maekawa does not specifically disclose monitors that are mounted at the junction of the sidewall and ceiling and directed obliquely downwardly toward the car seats (see page 8 of the Office Action). However, the Office alleges that such a feature is taught by Amano. Furthermore, the Office alleges that Maekawa expressly discloses that the screen of the monitor is substantially flushed with the adjacent wall surface structure of the car, citing features 101 – 124, page 738, column 2, and Figures 1 and 2 of Maekawa. Patent Owner respectfully traverses.

Specifically, Maekawa fails to teach or suggest that “*the screen of the monitor [is] substantially flushed with the adjacent wall surface structure of the car*”. Page 738, column 2 of Maekawa states in relevant part: “...*each of the television receivers (101), (102), (103) ... (124) is made low profile using liquid crystal panels or the like.*” Accordingly, while Maekawa clearly contemplates low profile displays, Maekawa is completely silent as to these liquid crystal panels being substantially flushed with the adjacent wall surface structure of the car.

Again, the Office alleges that the term “*substantially*” is often used in conjunction with another term to describe a particular characteristic of the claimed invention and is further construed to be a broad term (citing MPEP §2173.05). Again, Patent Owner respectfully submits that the use of the term “*substantially*” cannot be construed so broadly as to read the term “*flushed*” completely out of the claim; see discussion provided *supra*. Figure 2 of Maekawa illustrates that no part of these low profile displays are “*flush*” with the adjacent wall surface structure of the car as Patent Owner has used that term in its specification and Claim 1. Figure 2 of Maekawa is reproduced below for the convenience of the Office.

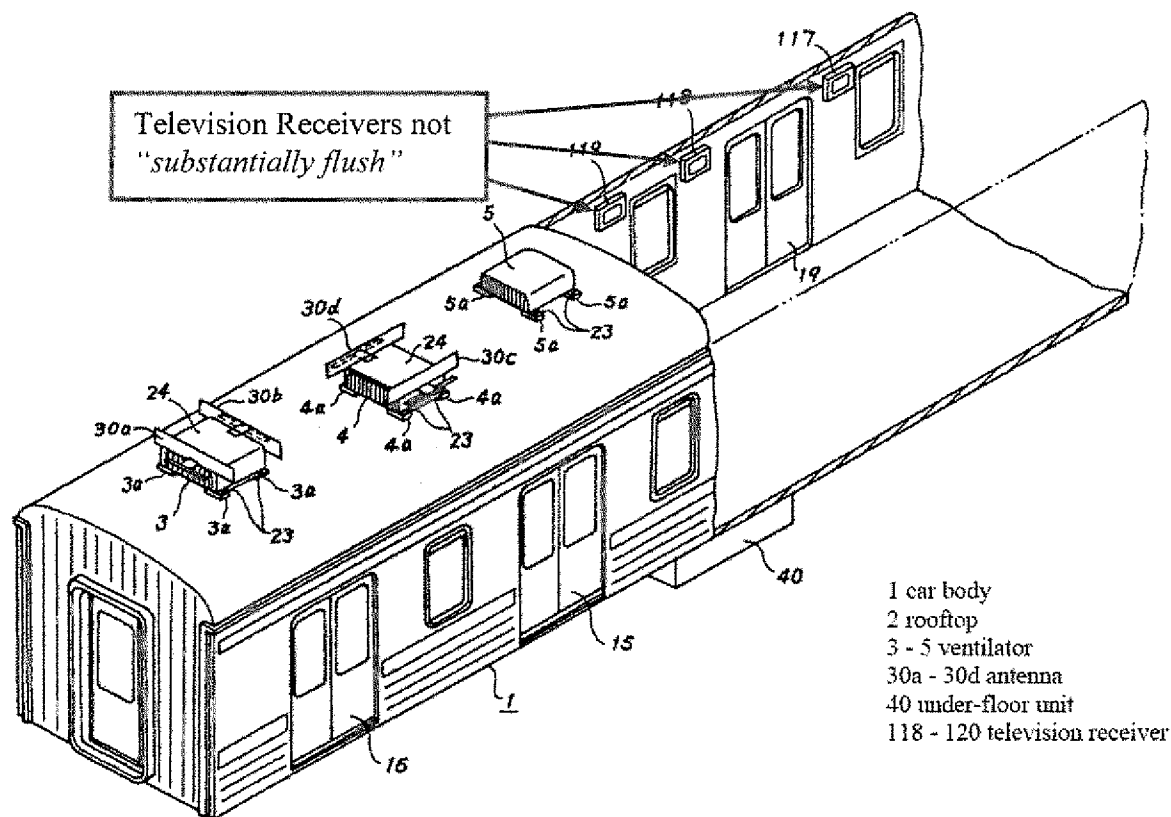

Figure 2 of Maekawa

As can be seen, there is not a single part of the television receiver illustrated in Figure 2 (including especially its screen) that is flush with the adjacent wall surface structure of the car; in fact, the entire television receiver of Maekawa clearly protrudes from the adjacent car wall surface. Accordingly, Patent Owner respectfully submits that the Office's interpretation of the term "substantially flushed" is improper, as the Office's interpretation completely reads out the "flushed" feature.

Patent Owner further submits that Amano does not cure the deficiencies present in Maekawa (see discussion of Amano with regards to the Office's 35 U.S.C. § 102 rejection above)

Accordingly, the Office's rejection of Claim 1 as being obvious over Maekawa in view of Amano is respectfully improper and should be withdrawn.

4. Per page 9 of the Office Action, Claim 1 stands rejected under 35 U.S.C. §103 as being unpatentable over Shinagawa et al. (Japanese Publication No. JP 61-285490, hereinafter

Control No. : 90/011,861
Filed : August 16, 2011

“Shinagawa”) in view of Amano. In response thereto, Patent Owner provides the following remarks:

5 **Claim 1** – With regards to Claim 1, the Office admits that Shinegawa does not specifically disclose monitors that are mounted at the junction of the sidewall and ceiling and directed obliquely downwardly toward the car seats (see page 10 of the Office Action). However, the Office alleges that such a feature is taught by Amano. Furthermore, the Office alleges that Shinegawa explicitly discloses that the screen of the monitor is substantially flushed with the adjacent wall surface structure of the car, citing features 21 to 2n, page 621, column 1 and Figures 1 and 4 of
10 Shinegawa. Patent Owner respectfully traverses.

Specifically, Shinegawa fails to teach or suggest that “*the screen of the monitor [is] substantially flushed with the adjacent wall surface structure of the car*”. Page 621, column 1 of Shinegawa states in relevant part: “... preferably, the display devices 21 to 2n are arranged on the walls flanking the aisles of each train or above the windows of the passenger seats at
15 approximately the eye level of an average adult walking by.” Shinegawa is completely silent as to having the screen of the monitor be substantially flushed with the adjacent wall surface structure of the car. Figures 1 and 4 of Shinegawa appear equally silent on monitors being substantially flushed with the adjacent wall surface.

Here again, the Office alleges that the term “*substantially*” is often used in conjunction
20 with another term to describe a particular characteristic of the claimed invention and is further construed to be a broad term (citing MPEP §2173.05). Again, Patent Owner respectfully submits that the use of the term “*substantially*” cannot be construed so broadly as to read the term “*flushed*” completely out of the claim; see discussion *supra*. Patent Owner notes that there is nothing in Shinegawa which would teach or suggest that any portion of the display devices are
25 mounted substantially flushed with the adjacent wall surface structure. Accordingly, the Office’s interpretation of the term “*substantially flushed*” is respectfully improper, as the Office’s interpretation completely reads out the “*flushed*” feature.

Patent Owner further submits that Amano does not cure the deficiencies present in Shinegawa (see discussion of Amano with regards to the Office’s 35 U.S.C. § 102 rejection above)

Control No. : 90/011,861
Filed : August 16, 2011

Accordingly, the Office's rejection of Claim 1 as being obvious over Shinegawa in view of Amano is respectfully improper and should be withdrawn.

5 5. Per page 12 of the Office Action, Claim 1 stands rejected under 35 U.S.C. §103 as being unpatentable over Minesaki in view of Moore et al. (U.S. Patent No. 3,480,727, hereinafter "Moore"). In response thereto, Patent Owner provides the following remarks:

10 **Claim 1** – Patent Owner respectfully traverses the Office's contention that Claim 1 is obvious over Minesaki in view of Moore. Specifically, and as discussed previously herein with regards to Patent Owner's discussion of Minesaki *supra*, Minesaki fails to teach or suggest: (1) *"each of said monitor being mounted at the junction of the sidewall and ceiling"*; and (2) *"directed obliquely downwardly toward the car seats"*.

15 Furthermore, Patent Owner submits that Moore does not cure the deficiencies found in Minesaki, as Moore is only being utilized for its teaching of a monitor adapted to be mounted flush with a surrounding wall, and teaches nothing of the placement of the monitor within the wall (e.g., at a junction or otherwise).

Accordingly, Patent Owner respectfully submits that the Office's rejection of Claim 1 as being unpatentable over Minesaki in view of Moore is improper and should be withdrawn.

20 6. Per page 15 of the Office Action, Claim 1 stands rejected under 35 U.S.C. §103 as being unpatentable over Amano in view of Moore. In response thereto, Patent Owner provides the following remarks:

25 **Claim 1** – Patent Owner respectfully traverses the Office's rejection of Claim 1 as being unpatentable over Amano in view of Moore. In making the rejection, the Office Action alleges, in part, that it would have been obvious for one of ordinary skill in the art to arrive at *"the screen of the monitor [being] substantially flushed with the adjacent wall surface structure of the car"* by combining the monitors mounted near the junction of the sidewall and ceiling of Amano (see Figures 4 – 6 of Amano) with the teaching of a monitor adapted to be mounted flush
30 with a surrounding wall as taught by Moore. Patent Owner respectfully disagrees and traverses.

MPEP §2143.03(VI) states that: "[a] prior art reference must be considered in its entirety, i.e., as a whole, including portions that would lead away from the claimed invention." Accordingly, where cited art teaches away from a claimed feature, the cited art is not available for the purposes of an obviousness rejection.

5 Furthermore, if the "proposed modification would render the prior art invention being modified unsatisfactory for its intended purpose, then there is no suggestion or motivation to make the proposed modification. In re Gordon, 733 F.2d 900, 221 USPQ 1125 (Fed. Cir. 1984)". See also MPEP § 2143.01.

10 In the instant case, Amano fails to teach or suggest "the screen of the monitor [being] substantially flushed with the adjacent wall surface structure of the car". However, the Office states that the monitor of Amano can readily and predictably be substituted with the flush monitor of Moore. To the contrary, Patent Owner respectfully submits that the wall structure of Amano (in particular, the area near the junction of the sidewall and ceiling) would need to be appreciably modified in order to accommodate a flush monitor. See also, for example, FIG. 4a
15 of the '602 Patent. However, Amano also illustrates storage areas on the upper areas of the train. See for example, Figure 4 of Amano reproduced below.

Figure 4

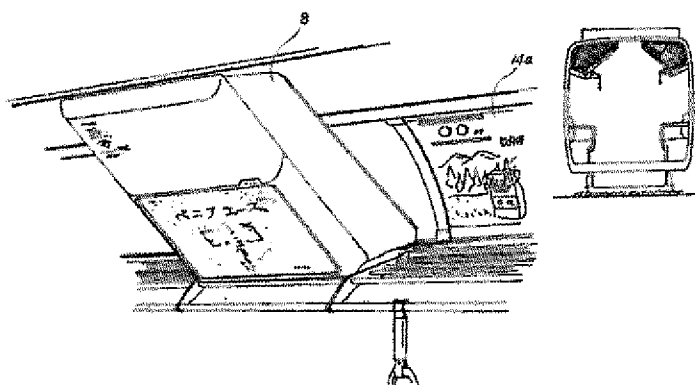

Figure 4 of Amano

20 Accordingly, modifications to the area near the junction of the sidewall and ceiling of the Amano train would render the Amano train unsatisfactory for its intended purpose. For example, if the wall surface structure near the information display device 8 were to be extended so that the screen of the information display device 8 were "substantially flushed" with its adjacent walls, the storage areas would need to be substantially reduced in size or eliminated entirely. It

Control No. : 90/011,861
Filed : August 16, 2011

is not clear to Patent Owner why one would be motivated to make such a modification, where the modification would remove desirable storage area on the train of Amano, thereby leading to a situation where no overhead storage is available for passengers' luggage or other items. By analogy, one would not design a commercial airliner such that no overhead storage was available (thereby requiring passengers to check all baggage).

Note also that the cross-sectional view in FIG. 4 of Amano reproduced above shows a thin outer shell or body for the train car with seemingly little or no interior volume of space, thereby frustrating mounting of the monitor screen flush therewith (otherwise, the back of the monitor, wiring, etc, would protrude through the car body and be exposed on the outside, which is clearly undesirable).

Furthermore, it is a stated purpose of Amano to take the opportunity to effectively use the time on a transportation vehicle to provide various information to people who are using various cited transportation vehicles (i.e., airplane, train and bus). Accordingly, if Amano were modified so that the display devices 8 were flush with the adjacent wall surface structure of the car, and the storage areas were modified to protrude further away from the sidewall to accommodate for the space taken up by the flush mounted monitors, passengers would place luggage or other articles onto these storage areas thereby obscuring the display of information on these display devices from the passengers on the transportation vehicle, in direct contravention with the stated purpose of Amano.

Amano does not appear to explicitly describe the reasoning behind the placement of the information signal display devices near the junction of the ceiling and the sidewall. However, it appears reasonable to infer that since each of the respective embodiments which illustrate this feature (i.e. FIGS. 4 – 6) also include areas for overhead storage, that the placement of the information signal display devices is merely necessitated because of the existence of these overhead storage areas; i.e., they would not otherwise be able to be accommodated on the sidewall areas as illustrated in, for example, Maekawa, as the overhead storage areas interface with the sidewall in these traditional information signal display device mounting areas.

Therefore, as the proposed modification to Amano would render the Amano storage areas (or information display devices 8) unsatisfactory for their intended purpose, one of ordinary skill in the art would not be motivated to modify Amano to incorporate certain features

Control No. : **90/011,861**
Filed : **August 16, 2011**

of Moore in an effort to arrive at the claimed invention. Accordingly, Patent Owner respectfully submits that the rejection is improper and respectfully requests that the rejection be withdrawn.

7. Per pages 18 of the Office Action, Claim 1 stands rejected under 35 U.S.C. §103 as being unpatentable over Maekawa in view of Amano and further in view of Moore. Furthermore, per page 22 of the Office Action, Claim 1 stands rejected under 35 U.S.C. § 103 as being unpatentable over Shinagawa in view of Amano and further in view of Moore. In response thereto, Patent Owner provides the following remarks:

Claim 1 – In each of these respective instances, Maekawa and Shinagawa are both alleged to disclose all of the limitations of the claimed invention, except for specifically calling for each of the monitors to be mounted at the junction of the sidewall and ceiling and directed obliquely downwardly toward the car seats, with the screen of the monitor being substantially flushed with the adjacent wall surface structure. However, the Office utilizes Amano in combination with Moore to allegedly teach such features as claimed.

However, as discussed previously herein, Patent Owner respectfully submits that the proposed combination of Amano and Moore is improper, as the modification of Amano to include the flush monitors of Moore would render the Amano storage areas (or information display devices 8) unsatisfactory for their intended purpose. Accordingly, as the proposed modification would render the “*prior art invention being modified unsatisfactory for its intended purpose ... there is no suggestion or motivation to make the proposed modification*”.

Patent Owner respectfully requests withdrawal of the Office’s rejection of Claim 1 as being unpatentable over Maekawa in view of Amano and further in view of Moore; or alternatively as being unpatentable over Shinagawa in view of Amano and further in view of Moore.

New Claims

By this paper, Patent Owner has added new Claim 8 – 30 with new Claims 8, 15 and 21 being independent and new Claims 9 – 14, 16 – 20 and 22 – 30 being dependent. New independent Claims 8, 15 and 21 correspond generally, and without limitation or estoppel to

Control No. : 90/011,861
Filed : August 16, 2011

independent Claim 1. Furthermore, newly added independent 8, 15 and 21 do not enlarge the scope of Claim 1 and accordingly are believed to be in an allowable condition.

New dependent Claims 9 – 14, 16 – 20 and 22 – 30 depend either directly or indirectly from new independent Claims 8, 15 and 21 respectively and accordingly are believed to be in an allowable condition as well. Support for these newly added claims can be found as follows:

support for new Claims 9 and 22 can be found at, *inter alia*, Col. 3, lines 64 – 67 of the '602 Patent;

support for new Claims 10 and 23 can be found at, *inter alia*, Col. 4, lines 9 – 13 of the '602 Patent;

support for new Claims 11, 19, 20 and 24 can be found at, *inter alia*, Col. 6, lines 1 – 3 of the '602 Patent;

support for new Claims 12 and 25 can be found at, *inter alia*, Col. 5, lines 21 – 23 of the '602 Patent;

support for new Claims 13 and 26 can be found at, *inter alia*, Col. 5, lines 24 – 27 of the '602 Patent;

support for new Claims 14 and 27 can be found at, *inter alia*, Col. 5, lines 32 – 34 of the '602 Patent;

support for new Claims 16 and 28 can be found at, *inter alia*, Col. 4, lines 3 – 6 of the '602 Patent;

support for new Claims 17 and 29 can be found at, *inter alia*, Col. 3, lines 15 – 18 of the '602 Patent; and

support for new Claims 18 and 30 can be found at, *inter alia*, Col. 1, lines 43 – 44 of the '602 Patent.

Accordingly, no new matter has been entered by virtue of these newly added Claims.

Control No. : 90/011,861
Filed : August 16, 2011

Other Remarks

Assignee notes that any remarks made with respect to a given claim or claims are limited solely to such claim or claims, unless otherwise explicitly noted.

5 If the Examiner has any questions or comments which may be resolved over the telephone, he is respectfully requested to call the undersigned at (858) 675-1670.

Respectfully submitted,

GAZDZINSKI & ASSOCIATES, PC

10

Dated: March 9, 2012

By:



Peter J. Gutierrez, III
Registration No. 56,732
16644 West Bernardo Drive, Suite 201
San Diego, CA 92127
Telephone No.: (858) 675-1670
Facsimile No.: (858) 675-1674

15



UNITED STATES PATENT AND TRADEMARK OFFICE

UNITED STATES DEPARTMENT OF COMMERCE
United States Patent and Trademark Office
Address: COMMISSIONER FOR PATENTS
P.O. Box 1450
Alexandria, Virginia 22313-1450
www.uspto.gov

APPLICATION NO.	FILING DATE	FIRST NAMED INVENTOR	ATTORNEY DOCKET NO.	CONFIRMATION NO.
90/011,861	08/16/2011	6700602	BLAIR.001A	3736

27299 7590 04/25/2012
GAZDZINSKI & ASSOCIATES, PC
16644 WEST BERNARDO DRIVE
SUITE 201
SAN DIEGO, CA 92127

EXAMINER

ART UNIT PAPER NUMBER

DATE MAILED: 04/25/2012

Please find below and/or attached an Office communication concerning this application or proceeding.



DO NOT USE IN PALM PRINTER

(THIRD PARTY REQUESTER'S CORRESPONDENCE ADDRESS)

EX PARTE REEXAMINATION COMMUNICATION TRANSMITTAL FORM

REEXAMINATION CONTROL NO. 90/011,861.

PATENT NO. 6700602.

ART UNIT 3992.

Enclosed is a copy of the latest communication from the United States Patent and Trademark Office in the above identified *ex parte* reexamination proceeding (37 CFR 1.550(f)).

Where this copy is supplied after the reply by requester, 37 CFR 1.535, or the time for filing a reply has passed, no submission on behalf of the *ex parte* reexamination requester will be acknowledged or considered (37 CFR 1.550(g)).

Office Action in Ex Parte Reexamination	Control No. 90/011,861	Patent Under Reexamination 6700602
	Examiner STEPHEN RALIS	Art Unit 3992

-- The MAILING DATE of this communication appears on the cover sheet with the correspondence address --

- a Responsive to the communication(s) filed on 09 March 2012. b This action is made FINAL.
c A statement under 37 CFR 1.530 has not been received from the patent owner.

A shortened statutory period for response to this action is set to expire _____ month(s) from the mailing date of this letter. Failure to respond within the period for response will result in termination of the proceeding and issuance of an *ex parte* reexamination certificate in accordance with this action. 37 CFR 1.550(d). **EXTENSIONS OF TIME ARE GOVERNED BY 37 CFR 1.550(c)**. If the period for response specified above is less than thirty (30) days, a response within the statutory minimum of thirty (30) days will be considered timely.

Part I THE FOLLOWING ATTACHMENT(S) ARE PART OF THIS ACTION:

1. Notice of References Cited by Examiner, PTO-892. 3. Interview Summary, PTO-474.
2. Information Disclosure Statement, PTO/SB/08. 4. _____.

Part II SUMMARY OF ACTION

- 1a. Claims 1 and 8-30 are subject to reexamination.
1b. Claims 2-7 are not subject to reexamination.
2. Claims _____ have been canceled in the present reexamination proceeding.
3. Claims _____ are patentable and/or confirmed.
4. Claims 1,8-18 and 21-30 are rejected.
5. Claims 19 and 20 are objected to.
6. The drawings, filed on _____ are acceptable.
7. The proposed drawing correction, filed on _____ has been (7a) approved (7b) disapproved.
8. Acknowledgment is made of the priority claim under 35 U.S.C. § 119(a)-(d) or (f).
a) All b) Some* c) None of the certified copies have
1 been received.
2 not been received.
3 been filed in Application No. _____.
4 been filed in reexamination Control No. _____.
5 been received by the International Bureau in PCT application No. _____.
* See the attached detailed Office action for a list of the certified copies not received.
9. Since the proceeding appears to be in condition for issuance of an *ex parte* reexamination certificate except for formal matters, prosecution as to the merits is closed in accordance with the practice under *Ex parte* Quayle, 1935 C.D. 11, 453 O.G. 213.
10. Other: _____

cc: Requester (if third party requester)

DETAILED ACTION

1. This Office action addresses claims 1 and 8-30 of United States Patent Number 6,700,602 (Blair) for which it has been determined in the Order Granting Ex Partes Reexamination (hereafter the "Order") that a substantial new question of patentability for original claim 1 was raised in the Request for ex parte reexamination filed on 16 August 2011 (hereafter the "Request"). Claims 8-30 were added by Owner in the request for reconsideration filed 06 December 2011. This is a final Office action in response to the request for reconsideration filed 06 December 2011.

Response to Arguments

2. Applicant's arguments, see pages 12-14, filed 09 March 2012, with respect to claim 1 have been fully considered and are persuasive. The rejection of claim 1, in light of Shinagawa et al. alone, has been withdrawn.

Rejections Previously Proposed by the Requester

3. The following rejections are utilized by the examiner below, referencing the proposed prior art listed on page 2 of the non-final Office action mailed 11 January 2012. (**NOTE:** Issue 4 no longer exists, as set forth above and below)

Art Unit: 3992

- Issue 1: Claim 1 in view of Minesaki.
- Issue 2: Claim 1 in view of Amano et al.
- Issue 3: Claim 1 in view of Maekawa et al. and Amano et al.
- Issue 5: Claim 1 in view of Minesaki and Moore et al.
- Issue 6: Claim 1 in view of Amano et al. and Moore et al.
- Issue 7: Claim 1 in view of Maekawa et al., Amano et al. and Moore et al.
- Issue 8: Claim 1 in view of Shinagawa et al., Amano et al. and Moore et al.

Claim Rejection Paragraphs

4. The following quotations from the MPEP regarding the types of rejections to be utilized below:

Claim Rejections - 35 USC § 112

5. The following is a quotation of the first paragraph of 35 U.S.C. 112:

The specification shall contain a written description of the invention, and of the manner and process of making and using it, in such full, clear, concise, and exact terms as to enable any person skilled in the art to which it pertains, or with which it is most nearly connected, to make and use the same and shall set forth the best mode contemplated by the inventor of carrying out his invention.

Claim Rejections - 35 USC § 305

6. The following is a quotation of the second paragraph of 35 U.S.C. 305:

After the times for filing the statement and reply provided for by section 304 of this title have expired, reexamination will be conducted according to the procedures established for initial examination under the provisions of sections 132 and 133 of this title. In any reexamination proceeding under this chapter, the patent owner will be permitted to propose any amendment to his patent and a new claim or claims thereto, in order to distinguish the invention as claimed from the prior art cited under the provisions of section 301 of this title, or in response to a decision adverse to the patentability of a claim of a patent. No proposed amended or new claim enlarging the scope of a claim of the patent will be permitted in a reexamination proceeding under this chapter. All reexamination proceedings under this section, including any appeal to the Board of Patent Appeals and Interferences, will be conducted with special dispatch within the Office.

Claim Rejections - 35 USC § 102

7. The following is a quotation of the appropriate paragraphs of 35 U.S.C. 102 that form the basis for the rejections under this section made in this Office action:

A person shall be entitled to a patent unless –

(b) the invention was patented or described in a printed publication in this or a foreign country or in public use or on sale in this country, more than one year prior to the date of application for patent in the United States.

Claim Rejections - 35 USC § 103

8. The following is a quotation of 35 U.S.C. 103(a) which forms the basis for all obviousness rejections set forth in this Office action:

(a) A patent may not be obtained though the invention is not identically disclosed or described as set forth in section 102 of this title, if the differences between the subject matter sought to be patented and the prior art are such that the subject matter as a whole would have been obvious at the time the invention was made to a person having ordinary skill in the art to which said subject matter pertains. Patentability shall not be negated by the manner in which the invention was made.

Issue 1

9. Claim 1 is rejected under 35 U.S.C. 102(b) as being anticipated by Minesaki (Japanese. Publication No. JP 63-125984 of Japanese Application No. JP 61-272668).

With respect to the limitations of claim 1, Minesaki discloses a subway car (train cars; page 588, lines 6-10; page 590, lines 18-19) for mass transportation including longitudinal opposed sidewalls (9), a ceiling (top portion in Figure 2) adjoining the sidewalls (9), a video display system (control part G/information communication display part J combination) comprising a plurality of video display monitors (see references to J

Art Unit: 3992

on each side of sidewall 9 and ceiling interface in Figure 2) each having a video screen (display), and a video signal source unit (control part G) operatively connected to the monitors (see references to J on each side of sidewall 9 and ceiling interface in Figure 2), the monitors (see references to J on each side of sidewall 9 and ceiling interface in Figure 2) being spaced along the length of the car on opposed sides thereof (in the middle of the length of each sidewall opposite each other; see Figure 2), each of the monitors being mounted at the junction of the sidewall and ceiling (see Figure 2), with the screen (display) of the monitor (see one of references to J on each side of sidewall 9 and ceiling interface in Figure 2) substantially flushed with the adjacent wall surface structure of the car (see Figure 2), and directed obliquely downwardly toward the car seats (top portion of Information communication part J directed obliquely downwardly toward the car seats; see Figure 2) , so that each video screen (display) is readily visible to passengers in the subway car (train cars; page 588, lines 6-10; page 590, lines 18-19).

With respect to the limitation of claim 1 and “the screen of the monitor substantially flushed with the adjacent wall surface structure of the car”, the term “substantially” is often used in conjunction with another term to describe a particular characteristic of the claimed invention. It is a broad term. (See MPEP 2173.05). Minesaki explicitly discloses the screen (display) of the monitor (see one of references to J on each side of sidewall 9 and ceiling interface in Figure 2) being substantially flushed with the adjacent wall surface structure of the car (see Figure 2) given its broadest reasonable interpretation of “substantially flushed” in light of the Blair Patent

Art Unit: 3992

disclosure (column 5, line 35 – column 6, line 7; see Figures 4A-7). Therefore, Minesaki fully meets "the screen of the monitor substantially flushed with the adjacent wall surface structure of the car" given its broadest reasonable interpretation.

Issue 2

10. Claim 1 is rejected under 35 U.S.C. 102(b) as being anticipated by Amano et al. (Japanese. Publication No. JP 02-23985 A).

Amano et al. discloses a subway car (train cars; page 651, column 2, lines 5-10, 28-33; page 653, column 1, lines 43-45; see Figures 4-6) for mass transportation including longitudinal opposed sidewalls (see Figures 4-6), a ceiling (see Figures 4-6) adjoining the sidewalls (see Figures 4-6), a video display system (see Figure 2) comprising a plurality of video display monitors (**8; 8a-8n**; see Figures 2, 4-6) each having a video screen (**display**), and a video signal source unit (display information signal transmitter) operatively connected to the monitors (**8; 8a-8n**; see Figures 2, 4-6), the monitors (**8; 8a-8n**; see Figures 2, 4-6) being spaced along the length of the car on opposed sides thereof (in the middle of the length of each sidewall opposite each other; see Figures 4-6), each of the monitors being mounted at the junction of the sidewall and ceiling (see Figures 4-6), with the screen (**display**) of the monitor (**8; 8a-8n**; see Figures 2, 4-6) substantially flushed with the adjacent wall surface structure of the car (see Figure 4-6), and directed obliquely downwardly toward the car seats (see Figures 4-6), so that each video screen (**display**) is readily visible to passengers in the subway car

Art Unit: 3992

(train cars; page 651, column 2, lines 5-10, 28-33; page 653, column 1, lines 43-45; see Figures 4-6).

With respect to the limitation of “the screen of the monitor substantially flushed with the adjacent wall surface structure of the car”, the term “substantially” is often used in conjunction with another term to describe a particular characteristic of the claimed invention. It is a broad term. (See MPEP 2173.05). Minesaki explicitly discloses the screen (display) of the monitor (**8**; **8a-8n**; see Figures 2, 4-6) substantially flushed with the adjacent wall surface structure of the car (see Figures 4-6) given its broadest reasonable interpretation of “substantially flushed” in light of the Blair Patent disclosure (column 5, line 35 – column 6, line 7; see Figures 4A-7). Therefore, Amano et al. fully meets “the screen of the monitor substantially flushed with the adjacent wall surface structure of the car” given its broadest reasonable interpretation.

Issue 3

11. Claim 1 is rejected under 35 U.S.C. 103(a) as being unpatentable over Maekawa et al. (Japanese. Publication No. JP 04-160991 A) in view of Amano et al. (Japanese. Publication No. JP 02-23985 A).

Maekawa et al. discloses a subway car (car body of an electric train; page 738, column 2; see Figures 1, 2) for mass transportation including longitudinal opposed sidewalls (see Figures 1, 2), a ceiling (see Figures 1, 2) adjoining the sidewalls (see Figures 1, 2), a video display system (see Figure 1) comprising a plurality of video display monitors (**101-124**; page 738, column 2; see Figures 1, 2) each having a video

Art Unit: 3992

screen (display), and a video signal source unit (see Figure 1) operatively connected to the monitors (101-124; page 738, column 2; see Figures 1, 2), the monitors (101-124; page 738, column 2; see Figures 1, 2) being spaced along the length of the car on opposed sides thereof (see Figures 1, 2), with the screen (display) of the monitor (101-124; page 738, column 2; see Figures 1, 2) substantially flushed with the adjacent wall surface structure of the car (low profile; page 738; see Figure 2), so that each video screen (display) is readily visible to passengers in the subway car (car body of an electric train; page 738, column 2; see Figures 1, 2).

With respect to the limitation of “the screen of the monitor substantially flushed/blended with the adjacent wall surface structure of the car”, the term “substantially” is often used in conjunction with another term to describe a particular characteristic of the claimed invention. It is a broad term. (See MPEP 2173.05). Maekawa et al. explicitly discloses the screen (display) of the monitor being low profile, (101-124; page 738, column 2; see Figures 1, 2) substantially flushed with the adjacent wall surface structure of the car (see Figure 2) given its broadest reasonable interpretation of “substantially flushed” in light of the Blair Patent disclosure (column 5, line 35 – column 6, line 7; see Figures 4A-7). Therefore, Maekawa et al. et al. fully meets “the screen of the monitor substantially flushed/blended with the adjacent wall surface structure of the car” given its broadest reasonable interpretation.

Maekawa et al. discloses all of the limitations of the claimed invention, as previously set forth, except for specifically calling for each of the monitors being

Art Unit: 3992

mounted at the junction of the sidewall and ceiling and directed obliquely downwardly toward the car seats.

However, each of the monitors being mounted at the junction of the sidewall and ceiling and directed obliquely downwardly toward the car seats is known in the art. Amano et al., for example, teaches each of the monitors being mounted at the junction of the sidewall and ceiling (see Figures 4-6) and directed obliquely downwardly toward the car seats (see Figures 4-6). Amano et al. further teaches such a configuration presents a means to provide the offering place for information in transportation equipment being used more effectively and sharpness being obtained, thereby increasing the information offering ability to passengers (English translation Abstract). It would have been obvious to one of ordinary skill in the art at the time of the invention was made to modify the mounting and screen direction orientation of the monitors of Maekawa et al. with each of the monitors being mounted at the junction of the sidewall and ceiling and directed obliquely downwardly toward the car seats of Amano et al. in order to present a means to provide the offering place for information in transportation equipment being used more effectively and sharpness being obtained, thereby increasing the information offering ability to passengers.

12. To the degree it can be argued that "Minesaki", "Amano et al.", and/or "Maekawa et al." and/or " do not disclose "the screen of the monitor substantially flushed/blended or flushed with the adjacent wall surface structure of the car"; and "the video display monitor being substantially contiguous with an exterior surface of said transitional

Art Unit: 3992

segment" given their broadest reasonable interpretation, the additional rejections are provided as set forth below:

Issue 5

13. Claim 1 is rejected under 35 U.S.C. 103(a) as being unpatentable over Minesaki (Japanese. Publication No. JP 63-125984 of Japanese Application No. JP 61-272668) in view of Moore et al. (U.S. Patent No. 3,480,727).

With respect to the limitations of claim 1, Minesaki discloses a subway car (train cars; page 588, lines 6-10; page 590, lines 18-19) for mass transportation including longitudinal opposed sidewalls (9), a ceiling (top portion in Figure 2) adjoining the sidewalls (9), a video display system (control part G/information communication display part J combination) comprising a plurality of video display monitors (see references to J on each side of sidewall 9 and ceiling interface in Figure 2) each having a video screen (display), and a video signal source unit (control part G) operatively connected to the monitors (see references to J on each side of sidewall 9 and ceiling interface in Figure 2), the monitors (see references to J on each side of sidewall 9 and ceiling interface in Figure 2) being spaced along the length of the car on opposed sides thereof (in the middle of the length of each sidewall opposite each other; see Figure 2), each of the monitors being mounted at the junction of the sidewall and ceiling (see Figure 2), with the screen (display) of the monitor being projecting slightly beyond the adjacent wall surface structure of the car (see Figure 2) and directed obliquely downwardly toward the car seats (top portion of Information communication part J directed obliquely

Art Unit: 3992

downwardly toward the car seats; see Figure 2) , so that each video screen (**display**) is readily visible to passengers in the subway car (train cars; page 588, lines 6-10; page 590, lines 18-19).

Minesaki discloses all of the limitations of the claimed invention, as previously set forth, except for specifically calling for the screen of the monitor being substantially flushed with the adjacent wall surface structure instead of the monitor being projecting slightly beyond the adjacent wall surface structure.

However, a screen of the monitor being substantially flushed with the adjacent wall surface structure is known in the art. Moore et al., for example, teach a screen of the monitor being substantially flushed with the adjacent wall surface structure as being an equivalent structure in the art (column 7, lines 41-44). Moore et al. further teaches such a configuration provides a means to compensate for wall thickness or, the availability of space beyond the surface of the wall (column 7, lines 44-47). It would have been obvious to one of ordinary skill in the art at the time of the invention was made to modify the monitor being projecting slightly beyond the adjacent wall surface structure of the car of Minesaki with the screen of the monitor being substantially flushed with the adjacent wall surface structure of Moore et al. in order to provide a means to compensate for wall thickness or, the availability of space beyond the surface of the wall. In addition, because these two monitor/wall configurations were art recognized equivalents at the time the invention was made, one of ordinary skill in the art would have found it obvious to substitute a screen of the monitor being substantially

Art Unit: 3992

flushed with the adjacent wall surface structure for a monitor being projecting slightly beyond the adjacent wall surface structure.

Similarly, the examiner asserts that applying a known technique to a known device ready for improvement would yield predictable results. That is, it would have been recognized by one of ordinary skill in the art that applying the known technique taught by Moore et al. to the subway car of Minesaki would have yielded predictable results and resulted in an improved system, namely, a screen of the monitor being substantially flushed with the adjacent wall surface structure for a monitor being projecting slightly beyond the adjacent wall surface structure in Minesaki to provide a means to compensate for wall thickness or, the availability of space beyond the surface of the wall.

Moreover, the examiner asserts that simple substitution of one known element for another would obtain predictable results. That is, the substitution of one known element (a screen of the monitor being substantially flushed with the adjacent wall surface structure as shown in Moore et al.) for another (a monitor being projecting slightly beyond the adjacent wall surface structure as shown in Moore et al. and Minesaki) would have been obvious to one of ordinary skill in the art at the time of the invention since the substitution of a screen of the monitor being substantially flushed with the adjacent wall surface structure in Minesaki would have yielded predictable results, namely, providing a screen of the monitor being substantially flushed with the adjacent wall surface structure in Minesaki to provide a means to compensate for wall thickness or, the availability of space beyond the surface of the wall.

Art Unit: 3992

Furthermore, the examiner asserts use of known technique to improve similar devices in the same way is obvious to one of ordinary skill in the art. That is, the manner of enhancing a particular device (providing a screen of the monitor being substantially flushed with the adjacent wall surface structure) was made part of the ordinary capabilities of one skilled in the art based upon the teaching of such improvement in Moore et al. Accordingly, one of ordinary skill in the art would have been capable of applying this known "improvement" technique in the same manner to the prior art subway car of Minesaki and the results would have been predictable to one of ordinary skill in the art, namely, one skilled in the art would have readily recognized that providing a screen of the monitor being substantially flushed with the adjacent wall surface structure in Minesaki would positively provide a means to compensate for wall thickness or, the availability of space beyond the surface of the wall.

Issue 6

14. Claim 1 is rejected under 35 U.S.C. 103(a) as being unpatentable over Amano et al. (Japanese. Publication No. JP 02-23985 A) in view of Moore et al. (U.S. Patent No. 3,480,727).

With respect to the limitations of claim 1, Amano et al. discloses a subway car (train cars; page 651, column 2, lines 5-10, 28-33; page 653, column 1, lines 43-45; see Figures 4-6) for mass transportation including longitudinal opposed sidewalls (see Figures 4-6), a ceiling (see Figures 4-6) adjoining the sidewalls (see Figures 4-6), a video display system (see Figure 2) comprising a plurality of video display monitors (8;

Art Unit: 3992

8a-8n; see Figures 2, 4-6) each having a video screen (display), and a video signal source unit (display information signal transmitter) operatively connected to the monitors (8; 8a-8n; see Figures 2, 4-6), the monitors (8; 8a-8n; see Figures 2, 4-6) being spaced along the length of the car on opposed sides thereof (in the middle of the length of each sidewall opposite each other; see Figures 4-6), each of the monitors being mounted at the junction of the sidewall and ceiling (see Figures 4-6), with the screen (display) of the monitor being projecting slightly beyond the adjacent wall surface structure of the car (see Figures 4-6) and directed obliquely downwardly toward the car seats (see Figures 4-6), so that each video screen (display) is readily visible to passengers in the subway car (train cars; page 651, column 2, lines 5-10, 28-33; page 653, column 1, lines 43-45; see Figures 4-6).

Amano et al. discloses all of the limitations of the claimed invention, as previously set forth, except for specifically calling for the screen of the monitor being substantially flushed with the adjacent wall surface structure instead of the monitor being projecting slightly beyond the adjacent wall surface structure.

However, a screen of the monitor being substantially flushed with the adjacent wall surface structure is known in the art. Moore et al., for example, teach a screen of the monitor being substantially flushed with the adjacent wall surface structure as being an equivalent structure in the art (column 7, lines 41-44). Moore et al. further teaches such a configuration provides a means to compensate for wall thickness or, the availability of space beyond the surface of the wall (column 7, lines 44-47). It would have been obvious to one of ordinary skill in the art at the time of the invention was

Art Unit: 3992

made to modify the monitor being projecting slightly beyond the adjacent wall surface structure of the car of Amano et al. with the screen of the monitor being substantially flushed with the adjacent wall surface structure of Moore et al. in order to provide a means to compensate for wall thickness or, the availability of space beyond the surface of the wall. In addition, because these two monitor/wall configurations were art recognized equivalents at the time the invention was made, one of ordinary skill in the art would have found it obvious to substitute a screen of the monitor being substantially flushed with the adjacent wall surface structure for a monitor being projecting slightly beyond the adjacent wall surface structure.

Similarly, the examiner asserts that applying a known technique to a known device ready for improvement would yield predictable results. That is, it would have been recognized by one of ordinary skill in the art that applying the known technique taught by Moore et al. to the subway car of Amano et al. would have yielded predictable results and resulted in an improved system, namely, a screen of the monitor being substantially flushed with the adjacent wall surface structure for a monitor being projecting slightly beyond the adjacent wall surface structure in Amano et al. to provide a means to compensate for wall thickness or, the availability of space beyond the surface of the wall.

Moreover, the examiner asserts that simple substitution of one known element for another would obtain predictable results. That is, the substitution of one known element (a screen of the monitor being substantially flushed with the adjacent wall surface structure as shown in Moore et al.) for another (a monitor being projecting

Art Unit: 3992

slightly beyond the adjacent wall surface structure as shown in Moore et al. and Amano et al.) would have been obvious to one of ordinary skill in the art at the time of the invention since the substitution of a screen of the monitor being substantially flushed with the adjacent wall surface structure in Amano et al. would have yielded predictable results, namely, providing a screen of the monitor being substantially flushed with the adjacent wall surface structure in Amano et al. to provide a means to compensate for wall thickness or, the availability of space beyond the surface of the wall.

Furthermore, the examiner asserts use of known technique to improve similar devices in the same way is obvious to one of ordinary skill in the art. That is, the manner of enhancing a particular device (providing a screen of the monitor being substantially flushed with the adjacent wall surface structure) was made part of the ordinary capabilities of one skilled in the art based upon the teaching of such improvement in Moore et al. Accordingly, one of ordinary skill in the art would have been capable of applying this known "improvement" technique in the same manner to the prior art subway car of Amano et al. and the results would have been predictable to one of ordinary skill in the art, namely, one skilled in the art would have readily recognized that providing a screen of the monitor being substantially flushed with the adjacent wall surface structure in Amano et al. would positively provide a means to compensate for wall thickness or, the availability of space beyond the surface of the wall.

Issue 7

Art Unit: 3992

15. Claim 1 is rejected under 35 U.S.C. 103(a) as being unpatentable over Maekawa et al. (Japanese. Publication No. JP 04-160991 A) in view of Amano et al. (Japanese. Publication No. JP 02-23985 A) and Moore et al. (U.S. Patent No. 3,480,727).

With respect to the limitations of claim 1, Maekawa et al. discloses a subway car (car body of an electric train; page 738, column 2; see Figures 1, 2) for mass transportation including longitudinal opposed sidewalls (see Figures 1, 2), a ceiling (see Figures 1, 2) adjoining the sidewalls (see Figures 1, 2), a video display system (see Figure 1) comprising a plurality of video display monitors (101-124; page 738, column 2; see Figures 1, 2) each having a video screen (display), and a video signal source unit (see Figure 1) operatively connected to the monitors (101-124; page 738, column 2; see Figures 1, 2), the monitors (101-124; page 738, column 2; see Figures 1, 2) being spaced along the length of the car on opposed sides thereof (see Figures 1, 2), so that each video screen (display) is readily visible to passengers in the subway car (car body of an electric train; page 738, column 2; see Figures 1, 2).

Maekawa et al. discloses all of the limitations of the claimed invention, as previously set forth, except for specifically calling for each of the monitors being mounted at the junction of the sidewall and ceiling and directed obliquely downwardly toward the car seats; and the screen of the monitor being substantially flushed with the adjacent wall surface structure instead of the monitor being projecting slightly beyond the adjacent wall surface structure.

However, each of the monitors being mounted at the junction of the sidewall and ceiling and directed obliquely downwardly toward the car seats is known in the art.

Art Unit: 3992

Amano et al., for example, teaches each of the monitors being mounted at the junction of the sidewall and ceiling (see Figures 4-6) and directed obliquely downwardly toward the car seats (see Figures 4-6). Amano et al. further teaches such a configuration presents a means to provide the offering place for information in transportation equipment being used more effectively and sharpness being obtained, thereby increasing the information offering ability to passengers (English translation Abstract). It would have been obvious to one of ordinary skill in the art at the time of the invention was made to modify the mounting and screen direction orientation of the monitors of Maekawa et al. with each of the monitors being mounted at the junction of the sidewall and ceiling and directed obliquely downwardly toward the car seats of Amano et al. in order to present a means to provide the offering place for information in transportation equipment being used more effectively and sharpness being obtained, thereby increasing the information offering ability to passengers.

Similarly, a screen of the monitor being substantially flushed with the adjacent wall surface structure is known in the art. Moore et al., for example, teach a screen of the monitor being substantially flushed with the adjacent wall surface structure as being an equivalent structure in the art (column 7, lines 41-44). Moore et al. further teaches such a configuration provides a means to compensate for wall thickness or, the availability of space beyond the surface of the wall (column 7, lines 44-47). It would have been obvious to one of ordinary skill in the art at the time of the invention was made to modify the monitor being projecting slightly beyond the adjacent wall surface structure of the car of Maekawa et al. with the screen of the monitor being substantially

Art Unit: 3992

flushed with the adjacent wall surface structure of Moore et al. in order to provide a means to compensate for wall thickness or, the availability of space beyond the surface of the wall. Furthermore, because these two monitor/wall configurations were art recognized equivalents at the time the invention was made, one of ordinary skill in the art would have found it obvious to substitute a screen of the monitor being substantially flushed with the adjacent wall surface structure for a monitor being projecting slightly beyond the adjacent wall surface structure.

Similarly, the examiner asserts that applying a known technique to a known device ready for improvement would yield predictable results. That is, it would have been recognized by one of ordinary skill in the art that applying the known technique taught by Moore et al. to the subway car of Maekawa et al. would have yielded predictable results and resulted in an improved system, namely, a screen of the monitor being substantially flushed with the adjacent wall surface structure for a monitor being projecting slightly beyond the adjacent wall surface structure in Maekawa et al. to provide a means to compensate for wall thickness or, the availability of space beyond the surface of the wall.

Moreover, the examiner asserts that simple substitution of one known element for another would obtain predictable results. That is, the substitution of one known element (a screen of the monitor being substantially flushed with the adjacent wall surface structure as shown in Moore et al.) for another (a monitor being projecting slightly beyond the adjacent wall surface structure as shown in Moore et al. and Maekawa et al.) would have been obvious to one of ordinary skill in the art at the time of

Art Unit: 3992

the invention since the substitution of a screen of the monitor being substantially flushed with the adjacent wall surface structure in Maekawa et al. would have yielded predictable results, namely, providing a screen of the monitor being substantially flushed with the adjacent wall surface structure in Maekawa et al. to provide a means to compensate for wall thickness or, the availability of space beyond the surface of the wall.

Furthermore, the examiner asserts use of known technique to improve similar devices in the same way is obvious to one of ordinary skill in the art. That is, the manner of enhancing a particular device (providing a screen of the monitor being substantially flushed with the adjacent wall surface structure) was made part of the ordinary capabilities of one skilled in the art based upon the teaching of such improvement in Moore et al. Accordingly, one of ordinary skill in the art would have been capable of applying this known "improvement" technique in the same manner to the prior art subway car of Maekawa et al. and the results would have been predictable to one of ordinary skill in the art, namely, one skilled in the art would have readily recognized that providing a screen of the monitor being substantially flushed with the adjacent wall surface structure in Maekawa et al. would positively provide a means to compensate for wall thickness or, the availability of space beyond the surface of the wall.

Issue 8

16. Claim 1 is rejected under 35 U.S.C. 103(a) as being unpatentable over Shinagawa et al. (Japanese. Publication No. JP 04-160991 A) in view of Amano et al.

Art Unit: 3992

(Japanese. Publication No. JP 02-23985 A) and Moore et al. (U.S. Patent No. 3,480,727).

With respect to the limitations of claim 1, Shinagawa et al. discloses a subway car (car of a train; page 619, column 1; see Figure 4) for mass transportation including longitudinal opposed sidewalls (see Figure 4), a ceiling (see Figure 4) adjoining the sidewalls (see Figure 4), a video display system (see Figure 1) comprising a plurality of video display monitors (21-2n; page 621, column 1; see Figures 1, 4) each having a video screen (**display**), and a video signal source unit (see Figure 1) operatively connected to the monitors (21-2n; page 621, column 1; see Figures 1, 4), the monitors (21-2n; page 621, column 1; see Figures 1, 4) being spaced along the length of the car on opposed sides thereof (page 621, column 1, paragraph 3; see Figures 1, 4), so that each video screen (**display**) is readily visible to passengers in the subway car (car of a train; page 619, column 1; see Figure 4).

Shinagawa et al. discloses all of the limitations of the claimed invention, as previously set forth, except for specifically calling for each of the monitors being mounted at the junction of the sidewall and ceiling and directed obliquely downwardly toward the car seats; and the screen of the monitor being substantially flushed with the adjacent wall surface structure instead of the monitor being projecting slightly beyond the adjacent wall surface structure.

However, each of the monitors being mounted at the junction of the sidewall and ceiling and directed obliquely downwardly toward the car seats is known in the art. Amano et al., for example, teaches each of the monitors being mounted at the junction

Art Unit: 3992

of the sidewall and ceiling (see Figures 4-6) and directed obliquely downwardly toward the car seats (see Figures 4-6). Amano et al. further teaches such a configuration presents a means to provide the offering place for information in transportation equipment being used more effectively and sharpness being obtained, thereby increasing the information offering ability to passengers (English translation Abstract). It would have been obvious to one of ordinary skill in the art at the time of the invention was made to modify the mounting and screen direction orientation of the monitors of Shinagawa et al. with each of the monitors being mounted at the junction of the sidewall and ceiling and directed obliquely downwardly toward the car seats of Amano et al. in order to present a means to provide the offering place for information in transportation equipment being used more effectively and sharpness being obtained, thereby increasing the information offering ability to passengers.

Similarly, a screen of the monitor being substantially flushed with the adjacent wall surface structure is known in the art. Moore et al. for example, teach a screen of the monitor being substantially flushed with the adjacent wall surface structure as being an equivalent structure in the art (column 7, lines 41-44). Moore et al. further teaches such a configuration provides a means to compensate for wall thickness or, the availability of space beyond the surface of the wall (column 7, lines 44-47). It would have been obvious to one of ordinary skill in the art at the time of the invention was made to modify the monitor being projecting slightly beyond the adjacent wall surface structure of the car of Shinagawa et al. with the screen of the monitor being substantially flushed with the adjacent wall surface structure of Moore et al. in order to

Art Unit: 3992

provide a means to compensate for wall thickness or, the availability of space beyond the surface of the wall. Furthermore, because these two monitor/wall configurations were art recognized equivalents at the time the invention was made, one of ordinary skill in the art would have found it obvious to substitute a screen of the monitor being substantially flushed with the adjacent wall surface structure for a monitor being projecting slightly beyond the adjacent wall surface structure.

Similarly, the examiner asserts that applying a known technique to a known device ready for improvement would yield predictable results. That is, it would have been recognized by one of ordinary skill in the art that applying the known technique taught by Moore et al. to the subway car of Shinagawa et al. would have yielded predictable results and resulted in an improved system, namely, a screen of the monitor being substantially flushed with the adjacent wall surface structure for a monitor being projecting slightly beyond the adjacent wall surface structure in Shinagawa et al. to provide a means to compensate for wall thickness or, the availability of space beyond the surface of the wall.

Moreover, the examiner asserts that simple substitution of one known element for another would obtain predictable results. That is, the substitution of one known element (a screen of the monitor being substantially flushed with the adjacent wall surface structure as shown in Moore et al.) for another (a monitor being projecting slightly beyond the adjacent wall surface structure as shown in Moore et al. and Shinagawa et al.) would have been obvious to one of ordinary skill in the art at the time of the invention since the substitution of a screen of the monitor being substantially

Art Unit: 3992

flushed with the adjacent wall surface structure in Shinagawa et al. would have yielded predictable results, namely, providing a screen of the monitor being substantially flushed with the adjacent wall surface structure in Shinagawa et al. to provide a means to compensate for wall thickness or, the availability of space beyond the surface of the wall.

Furthermore, the examiner asserts use of known technique to improve similar devices in the same way is obvious to one of ordinary skill in the art. That is, the manner of enhancing a particular device (providing a screen of the monitor being substantially flushed with the adjacent wall surface structure) was made part of the ordinary capabilities of one skilled in the art based upon the teaching of such improvement in Moore et al. Accordingly, one of ordinary skill in the art would have been capable of applying this known "improvement" technique in the same manner to the prior art subway car of Amano et al. and the results would have been predictable to one of ordinary skill in the art, namely, one skilled in the art would have readily recognized that providing a screen of the monitor being substantially flushed with the adjacent wall surface structure in Shinagawa et al. would positively provide a means to compensate for wall thickness or, the availability of space beyond the surface of the wall.

New Issues with Regard to Newly Presented Claims

The following rejections are utilized by the examiner below

Art Unit: 3992

- Issue 9: Claims 8-14 and 21-30 in view of 35 U.S.C. 112, first paragraph
- Issue 10: Claims 8-14 in view of 35 U.S.C. 305
- Issue 11: Claims 15-18 in view of Minesaki
- Issue 12: Claims 15-18 in view of Amano et al.
- Issue 13: Claims 15-18 in view of Maekawa et al. and Amano et al.
- Issue 14: Claims 15-18 in view of Minesaki and Moore et al.
- Issue 15: Claims 15-18 in view of Amano et al. and Moore et al.
- Issue 16: Claims 15-18 in view of over Maekawa et al., Amano et al. and Moore et al.
- Issue 17: Claims 15-18 in view of over Shinagawa et al., Amano et al. and Moore et al.
- Issue 18: Claim Objections of claims 19 and 20.

Issue 9

17. Claims 8-14 and 21-30 are rejected under 35 U.S.C. 112, first paragraph, as failing to comply with the written description requirement. The claim(s) contains subject matter which was not described in the specification in such a way as to reasonably convey to one skilled in the relevant art that the inventor(s), at the time the application was filed, had possession of the claimed invention.

In the instant reexamination proceedings, newly proposed claim 8 recites

wherein the monitors are spaced along the length of the car on opposed sides thereof, the monitors being disposed within the transitional wall portion such that

Art Unit: 3992

the video screen of the respective video display monitor substantially blends with the adjacent surface structure of the transitional wall portion and is also directed obliquely downwardly toward the car seats so that each video screen is readily visible to passengers in the subway car.

The instant Patent specification discloses

The screens are preferably covered with a rigid transparent unit, e.g. of polycarbonate, shaped to coincide with the shape of the internal wall of the subway car at the location of mounting. For example, when the monitor is mounted at the junction of the wall and ceiling of the subway car, where there is commonly provided a concavely curved segment of internal wall, the transparent cover unit is suitably similarly concavely curved, so that it can be mounted as a continuum with the internal walls and blended to contours thereof, with the monitor mounted behind it. (Column 3, line 64 – column 4, line 8; see Figure 6) and;

An alternative arrangement is shown in FIG. 6. Here the polycarbonate shield 44 is convexly curved, and is disposed further forward from the monitor screen 44. The shield 44 now blends with forward facing part 48 the exterior skin and body structure 34, to provide a perhaps more aesthetically appealing arrangement. (Column 5, lines 57-62)

The monitors (22, 22A) and the video screens (46, not labeled) thereof are within enclosures (42, 42A). The video screens (46, not labeled) are behind a shield (44, 44A). It is the shield 44A of the enclosure 42A that "blends" with the internal walls of the subway car not the actual video screens of the monitor (see Figures 4, 4A). Therefore, the recitation to "such that *the video screen of the respective video display monitor substantially blends with the adjacent surface structure of the transitional wall portion*" is deemed new matter.

Similarly, newly proposed claim 21 recites

said monitors being spaced along the length of the car on opposed sides thereof, each of said monitors being mounted at the junction of the sidewall and ceiling, with the screen of the monitor flushed with the adjacent wall surface structure of

Art Unit: 3992

the car, and directed obliquely downwardly toward the car seats, so that each video screen is readily visible to passengers in the subway car.

The instant Patent specification discloses

An alternative embodiment is illustrated in FIG. 4A, a view similar to that of FIG. 4. In this alternative embodiment, CRT video monitor 22 is replaced with an LCD-based video monitor 22A which is of thin, rectangular cross-section, and occupies less space in the ceiling structure of the car. Accordingly, it can be moved towards the ceiling so that its viewing screen is substantially flush with or even behind the light panel 40. This use of an LCD-based monitor gives a better aesthetic appearance to the inside of the subway car as a whole, as well as improving the display performance by minimizing the interference effects, as previously discussed. (Page 5, lines 35-46)

Included below is Figure 4A.

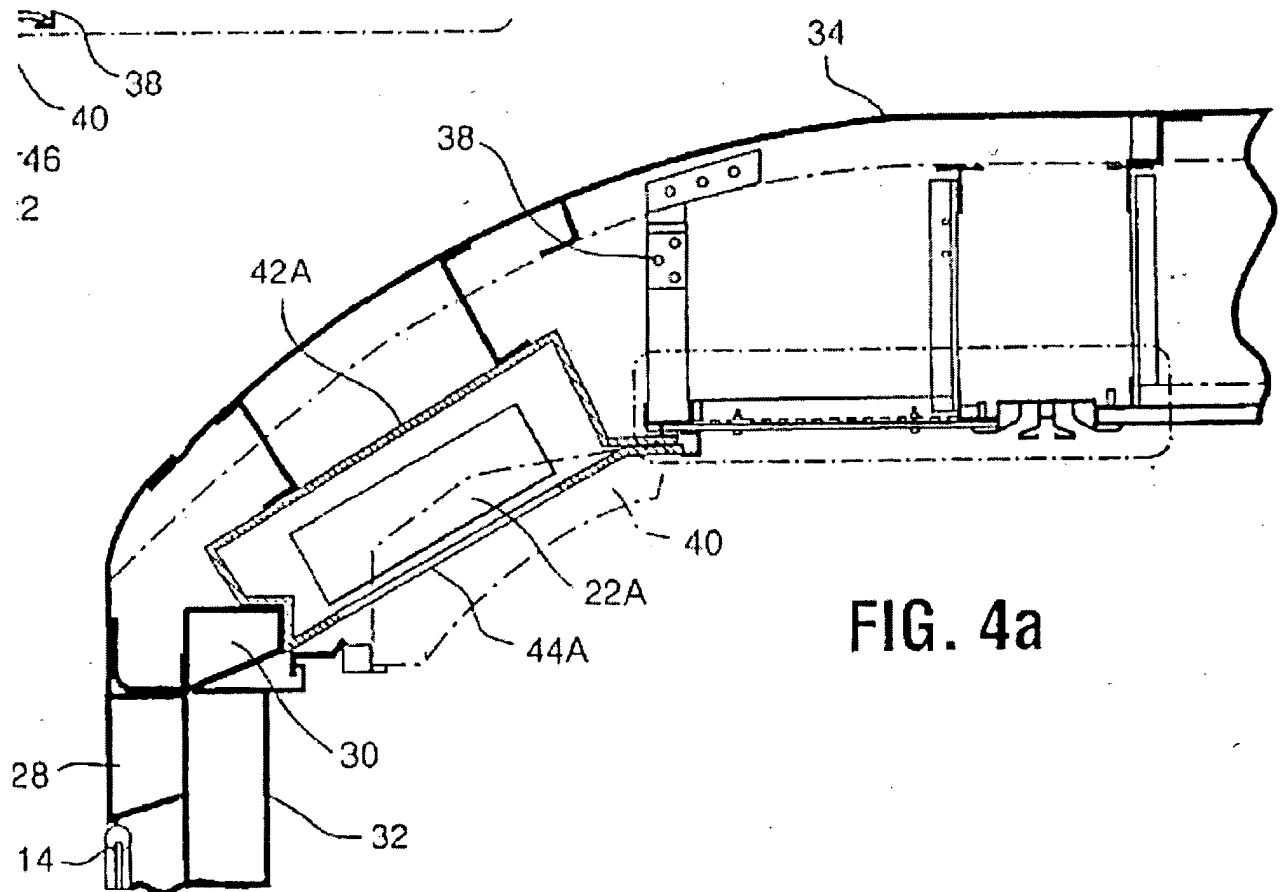

FIG. 4a

Art Unit: 3992

As asserted above, the

*“CRT video monitor is replaced with an LCD-based video monitor **22A** which is of thin, rectangular cross-section, and occupies less space in the ceiling structure of the car”.*

In Figure 4A, Owner explicitly discloses the monitor **22A** being behind the light panel **40** (see Figure 4A above). Owner alludes to the monitor **22A** being “substantially flush”, however, never provides explicit disclosure of the embodiment. Moreover, after further examination of Figure 4A, the actual viewing screen of the monitor **22A** can never really be flush with the light panel since the screen of the monitor **22A** is further behind the transport screen **44A** of the appropriately shaped enclosure **42A**, hence there is an actual space and/or distance between the actual viewing screen of the monitor **22A** and the transport screen **44A** of the appropriately shaped enclosure **42A**. Furthermore, Owner never defines the term “flushed” and only alludes to the disclosure of “substantially flushed” in light of Figure 4A. Figure 4A clearly does not show the embodiment of the screen being “substantially flushed” with the adjacent wall surface structure and, additionally provides evidence to the fact that the screen of the display monitor can never have or form a continuous plane or unbroken surface¹ with the adjacent wall surface structure, but can only form a surface that is offset therefrom or “substantially flushed”, in light of the Owner’s instant disclosure. Therefore, the recitation to “*with the screen of the monitor **flushed** with the adjacent wall surface structure of the car*” is deemed new matter.

Art Unit: 3992

18. Claims 8-14 and 21-30 are rejected under 35 U.S.C. 112, first paragraph, as failing to comply with the enablement requirement. The claim(s) contains subject matter which was not described in the specification in such a way as to enable one skilled in the art to which it pertains, or with which it is most nearly connected, to make and/or use the invention.

As asserted above, in the instant reexamination proceedings, newly proposed claim 8 recites

wherein the monitors are spaced along the length of the car on opposed sides thereof, the monitors being disposed within the transitional wall portion such that the video screen of the respective video display monitor substantially blends with the adjacent surface structure of the transitional wall portion and is also directed obliquely downwardly toward the car seats so that each video screen is readily visible to passengers in the subway car.

The instant Patent specification discloses

The screens are preferably covered with a rigid transparent unit, e.g. of polycarbonate, shaped to coincide with the shape of the internal wall of the subway car at the location of mounting. For example, when the monitor is mounted at the junction of the wall and ceiling of the subway car, where there is commonly provided a concavely curved segment of internal wall, the transparent cover unit is suitably similarly concavely curved, so that it can be mounted as a continuum with the internal walls and blended to contours thereof, with the monitor mounted behind it. (Column 3, line 64 – column 4, line 8; see Figure 6) and;

An alternative arrangement is shown in FIG. 6. Here the polycarbonate shield 44 is convexly curved, and is disposed further forward from the monitor screen 44. The shield 44 now blends with forward facing part 48 the exterior skin and body structure 34, to provide a perhaps more aesthetically appealing arrangement. (Column 5, lines 57-62)

¹ "flush." Merriam-Webster Online Dictionary. 2012. Merriam-Webster Online. 10 April 2012 <<http://www.merriam-webster.com/dictionary/flush>>

Art Unit: 3992

19. The monitors (22, 22A) and the video screens (46, not labeled) thereof are within enclosures (42, 42A). The video screens (46, not labeled) are behind a shield (44, 44A). It is the shield 44A of the enclosure 42A that "blends" with the internal walls of the subway car not the actual video screens of the monitor (see Figures 4, 4A). The examiner cannot ascertain a way to make the video screens (not labeled) of the monitor (22A) "substantially blend" with the adjacent surface structure of the transitional wall portion since there is the shield 44A that blends with the adjacent surface structure of the transitional wall portion. Therefore, the examiner deems the recitation to "such that the video screen of the respective video display monitor substantially blends with the adjacent surface structure of the transitional wall portion" is non-enabling.

Similarly, newly proposed claim 21 recites

said monitors being spaced along the length of the car on opposed sides thereof, each of said monitors being mounted at the junction of the sidewall and ceiling, with the screen of the monitor flushed with the adjacent wall surface structure of the car, and directed obliquely downwardly toward the car seats, so that each video screen is readily visible to passengers in the subway car.

The instant Patent specification discloses

An alternative embodiment is illustrated in FIG. 4A, a view similar to that of FIG. 4. In this alternative embodiment, CRT video monitor 22 is replaced with an LCD-based video monitor 22A which is of thin, rectangular cross-section, and occupies less space in the ceiling structure of the car. Accordingly, it can be moved towards the ceiling so that its viewing screen is substantially flush with or even behind the light panel 40. This use of an LCD-based monitor gives a better aesthetic appearance to the inside of the subway car as a whole, as well as improving the display performance by minimizing the interference effects, as previously discussed. (Page 5, lines 35-46)

Included below is Figure 4A.

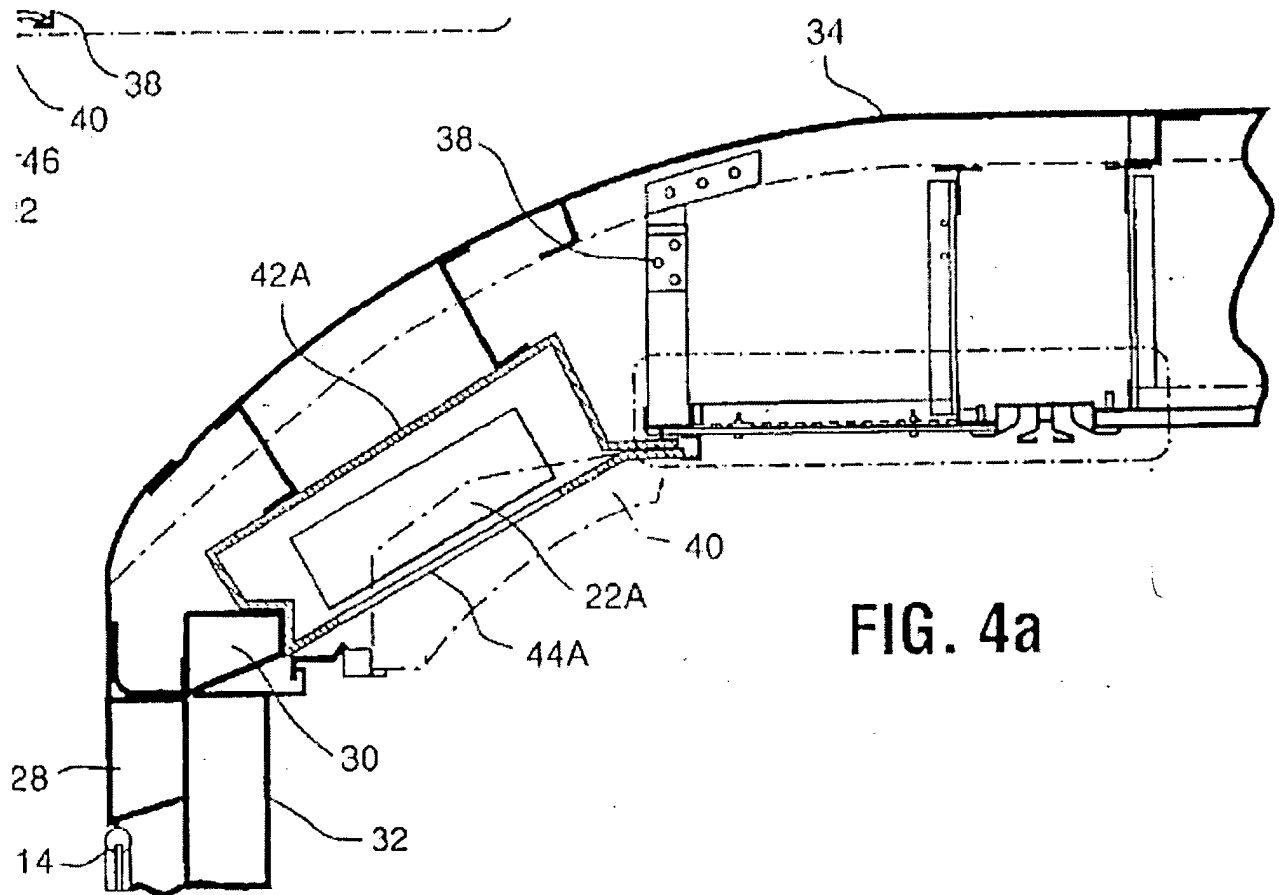

FIG. 4a

As asserted above, the

"CRT video monitor is replaced with an LCD-based video monitor 22A which is of thin, rectangular cross-section, and occupies less space in the ceiling structure of the car".

In Figure 4A, Owner explicitly discloses the monitor 22A being behind the light panel 40 (see Figure 4A above). Owner alludes to the monitor 22A being "substantially flush", however, never provides explicit disclosure of the embodiment. Moreover, after further examination of Figure 4A, the actual viewing screen of the monitor 22A can never really be flush with the light panel since the screen of the monitor 22A is further behind the transport screen 44A of the appropriately shaped enclosure 42A, hence there is an

Art Unit: 3992

actual space and/or distance between the actual viewing screen of the monitor **22A** and the transport screen **44A** of the appropriately shaped enclosure **42A**. Furthermore, Owner never defines the term “flushed” and only alludes to the disclosure of “substantially flushed” in light of Figure 4A. Figure 4A clearly does not show the embodiment of the screen being “substantially flushed” with the adjacent wall surface structure and, additionally provides evidence to the fact that the screen of the display monitor can never have or form a continuous plane or unbroken surface² with the adjacent wall surface structure, but can only form a surface that is offset therefrom or “substantially flushed”, in light of the Owner's instant disclosure. Furthermore, the examiner cannot ascertain a way to make the video screens (**not labeled**) of the monitor (**22A**) “flush” with the adjacent surface structure of the transitional wall portion since there is the shield **44A** that blends with the adjacent surface structure of the transitional wall portion. Therefore, the recitation to “*with the screen of the monitor **flushed** with the adjacent wall surface structure of the car*” is deemed non-enabling.

Issue 10

Claims 8-14 are rejected under 35 U.S.C. 305 as enlarging the scope of the claim(s) of the patent being reexamined. In 35 U.S.C. 305, it is stated that “[n]o proposed amended or new claim enlarging the scope of a claim of the patent will be permitted in a reexamination proceeding... .” A claim presented in a reexamination “enlarges the scope” of the patent claim(s) where the claim is broader than any claim of

² “flush.” Merriam-Webster Online Dictionary. 2012. Merriam-Webster Online. 10 April 2012

Art Unit: 3992

the patent. A claim is broader in scope than the original claims if it contains within its scope any conceivable product or process which would not have infringed the original patent. A claim is broadened if it is broader in any one respect, even though it may be narrower in other respects.

In the instant reexamination proceedings, newly proposed claim 8 recites

wherein the monitors are spaced along the length of the car on opposed sides thereof, the monitors being disposed within the transitional wall portion such that the video screen of the respective video display monitor substantially blends with the adjacent surface structure of the transitional wall portion and is also directed obliquely downwardly toward the car seats so that each video screen is readily visible to passengers in the subway car.

Original claim 1 (i.e. the only respective original independent claim) recites

said monitors being spaced along the length of the car on opposed sides thereof, each of said monitor being mounted at the junction of the sidewall and ceiling, with the screen of the monitor substantially flushed with the adjacent wall surface structure of the car, and directed obliquely downwardly toward the car seats, so that each video screen is readily visible to passengers in the subway car.

The term "*flushed*" is defined as "*forming a continuous plane or unbroken surface*" as asserted above and below. The term "*blended*" is defined as "*combining into an integrated whole*"³. Clearly the term "*blended*" or "*combining into an integrated whole*" does not require the particulars of being flushed or *forming a continuous plane or unbroken surface*⁴ (i.e. **does not require the video screen monitor and adjacent wall surface of the car be in the same continuous plane or even provide an unbroken surface, only to the video screen monitor and adjacent wall surface of the car**

<<http://www.merriam-webster.com/dictionary/flush>>

³ blend." Merriam-Webster Online Dictionary. 2012. Merriam-Webster Online. 10 April 2012

<<http://www.merriam-webster.com/dictionary/blend>>

Art Unit: 3992

being combined into an integrated whole), hence the limitation to "substantially blended" would be broader than the original recitation of "substantially flushed".

Therefore, the recitation to "*such that the video screen of the respective video display monitor substantially blends with the adjacent surface structure of the transitional wall portion*" is deemed as enlarging the scope of the claim(s) of the Patent being reexamined and, thus, independent claim 8 is rejected under 35 U.S.C. 305, as set forth above.

Issue 11

20. Claims 15-18 are rejected under 35 U.S.C. 102(b) as being anticipated by Minesaki (Japanese. Publication No. JP 63-125984 of Japanese Application No. JP 61-272668).

With respect to the limitation of claim 15, Minesaki discloses

A subway car for mass transportation

As shown in Figure 2, Minesaki discloses train cars in which information is displayed during transit (train cars; page 588, lines 6-10; page 590, lines 18-19).

including longitudinal opposed sidewalls that further comprise a transitional segment and a ceiling adjoining the sidewalls with the transitional segment disposed at the junction of the sidewall and the ceiling,

⁴ "flush." Merriam-Webster Online Dictionary. 2012. Merriam-Webster Online. 10 April 2012
<<http://www.merriam-webster.com/dictionary/flush>>

Art Unit: 3992

In addition, Minesaki discloses the train car including a pair of longitudinal opposed sidewalls (9) with each sidewall having a top curved portion/transitional wall portion at the junction between sidewall 9 and ceiling in Figure 2. Moreover, as is shown in Figure 2, Minesaki discloses a portion of top curved portion/transitional wall portion being directed/inclined downward towards the seat of the train car at an angle not including 90, 180 or 270 degrees (i.e. obliquely; see Figure 2). Similarly, Minesaki discloses a top portion of the train car which is considered to be the ceiling which is right next to and connected to the sidewalls 9, accordingly (see Figure 2).

the subway car further comprising: a video display system comprising: a plurality of video display monitors each having a video screen; and a video signal source unit operatively connected to said video display monitors;

Minesaki clearly discloses a video display system, in Figure 5, including a plurality of video display monitors (see references to J on each side of sidewall 9 and ceiling interface in Figure 2) with each having a video screen (display) as well as a video signal source unit (control part G) operatively connected to said video display monitors (see references to J on each side of sidewall 9 and ceiling interface in Figure 2 as well as Figure 1).

wherein said video display monitors are spaced along the length of the car on opposing sides of the subway, each of the video display monitors being mounted within the transitional segment, with the video screen of each video display monitor being substantially contiguous with an exterior surface of said transitional segment, said video screen being directed obliquely downwardly toward the car seats so that each video screen is readily visible to passengers in the subway car.

Art Unit: 3992

With respect to the limitation of “*with the video screen of each video display monitor being **substantially contiguous** with an exterior surface of said transitional segment*” of claim 15, the examiner can find no explicit disclosure to each video display monitor being “substantially contiguous” or “contiguous” with an exterior surface of the transitional segment within the instant specification. The term “*contiguous*” is defined as “being in actual contact : touching along a boundary or at a point” or “touching or connected throughout in an unbroken sequence”⁵. The examiner looks to the instant Patent specification to ascertain which definition would be comparable to the Owner’s instant Patent disclosure.

As asserted above, the instant Patent specification discloses

An alternative embodiment is illustrated in FIG. 4A, a view similar to that of FIG. 4. In this alternative embodiment, CRT video monitor 22 is replaced with an LCD-based video monitor 22A which is of thin, rectangular cross-section, and occupies less space in the ceiling structure of the car. Accordingly, it can be moved towards the ceiling so that its viewing screen is substantially flush with or even behind the light panel 40. This use of an LCD-based monitor gives a better aesthetic appearance to the inside of the subway car as a whole, as well as improving the display performance by minimizing the interference effects, as previously discussed. (Page 5, lines 35-46).

Similarly, the instant Patent specification discloses

The screens are preferably covered with a rigid transparent unit, e.g. of polycarbonate, shaped to coincide with the shape of the internal wall of the subway car at the location of mounting. For example, when the monitor is mounted at the junction of the wall and ceiling of the subway car, where there is commonly provided a concavely curved segment of internal wall, the transparent cover unit is suitably similarly concavely curved, so that it can be mounted as a continuum with the internal walls and blended to contours thereof, with the monitor mounted behind it. (Column 3, line64 – column 4, line 8; see Figure 6) and;

⁵ “contiguous.” Merriam-Webster Online Dictionary. 2012. Merriam-Webster Online. 10 April 2012
<<http://www.merriam-webster.com/dictionary/contiguous>>

Art Unit: 3992

*An alternative arrangement is shown in FIG. 6. Here **the polycarbonate shield 44 is convexly curved**, and is disposed further forward from the monitor screen 44. **The shield 44 now blends with forward facing part 48 the exterior skin and body structure 34**, to provide a perhaps more aesthetically appealing arrangement. (Column 5, lines 57-62)*

Again, as asserted above, the

"CRT video monitor is replaced with an LCD-based video monitor 22A which is of thin, rectangular cross-section, and occupies less space in the ceiling structure of the car".

In Figure 4A above, Owner explicitly discloses the monitor 22A being behind the light panel 40 (see Figure 4A above). Owner alludes to the monitor 22A being "substantially flush", however, never provides explicit disclosure of the embodiment. Moreover, after further examination of Figure 4A, the actual viewing screen of the monitor 22A can never really be flush with the light panel since the screen of the monitor 22A is further behind the transport screen 44A of the appropriately shaped enclosure 42A, hence there is an actual space and/or distance between the actual viewing screen of the monitor 22A and the transport screen 44A of the appropriately shaped enclosure 42A. Furthermore, Owner never defines the term "flushed" and only alludes to the disclosure of "substantially flushed" in light of Figure 4A. Figure 4A clearly does not show the embodiment of the screen being "substantially flushed" with the adjacent wall surface structure and, additionally provides evidence to the fact that the screen of the display monitor can never have or form a continuous plane or unbroken

Art Unit: 3992

surface⁶ with the adjacent wall surface structure, but can only form a surface that is offset therefrom or "substantially flushed", in light of the Owner's instant disclosure.

As asserted above, The term "*contiguous*" is defined as "being in actual contact : touching along a boundary or at a point" or "touching or connected throughout in an unbroken sequence"⁷. Since Owner discloses that the screen of the display monitor can never have or form a continuous plane or unbroken surface⁸ with the adjacent wall surface structure, but can only form a surface that is offset therefrom or "substantially flushed", the term "substantially contiguous" can only be "*not wholly* in actual contact : touching along a boundary or at a point" or offset therefrom not "touching or connected throughout in an unbroken sequence".

Therefore, the term "substantially contiguous" can only be deemed as "*not wholly* in actual contact : touching along a boundary or at a point" or a surface that is offset therefrom or "substantially flushed", since the Owner has further not explicitly defined the term "contiguous" or any embodiment of the instant Patent having a video screen of each video display monitor being **substantially contiguous** with an exterior surface of the transitional segment, only to an embodiment of a video screen of each video display monitor being **substantially flushed** or **a surface that is offset from** an exterior surface of the transitional segment (see explanation above). Furthermore, any other interpretation of the term "substantially contiguous" not being "*not wholly* in actual

⁶ "flush." Merriam-Webster Online Dictionary. 2012. Merriam-Webster Online. 10 April 2012
<<http://www.merriam-webster.com/dictionary/flush>>

⁷ "contiguous." Merriam-Webster Online Dictionary. 2012. Merriam-Webster Online. 10 April 2012
<<http://www.merriam-webster.com/dictionary/contiguous>>

⁸ "flush." Merriam-Webster Online Dictionary. 2012. Merriam-Webster Online. 10 April 2012
<<http://www.merriam-webster.com/dictionary/flush>>

Art Unit: 3992

contact : touching along a boundary or at a point” or “a surface that is offset therefrom” or “substantially flushed” would be deemed new matter since there is no explicit disclosure to any other embodiment.

In that light, Minesaki discloses the monitors (see references to **J** on each side of sidewall **9** and ceiling interface in Figure 2) being positioned in the middle of the length of each sidewall opposite each other (see Figure 2) with portions of the monitors (see references to **J** on each side of sidewall **9** and ceiling interface in Figure 2) being disposed/mounted within the top-curved region portion between the ceiling and sidewall **9** (see Figure 2). Such an arrangement of the monitors (see references to **J** on each side of sidewall **9** and ceiling interface in Figure 2) being disposed/mounted within the top-curved region portion between the ceiling and sidewall **9** (see Figure 2) would make each monitor (**J**) be “not wholly in actual contact with; or touching along a boundary or at a point”⁹ or “substantially contiguous” (i.e. substantially flushed or a surface that is offset, as set forth directly above) with the surface of the sidewall **9** facing the interior of the subway car in order to allow the portion of the monitor (**J**) lying in the top curved portion/transitional wall portion to be directed/inclined downward towards the seat of the train car at an angle not including 90, 180 or 270 degrees (i.e. obliquely; see Figure 2) so that each video screen (**display**) is readily visible to passengers in the train car.

With respect to the limitation of claim 16, Minesaki discloses

⁹ “contiguous.” Merriam-Webster Online Dictionary. 2012. Merriam-Webster Online. 10 April 2012 <<http://www.merriam-webster.com/dictionary/contiguous>>

Art Unit: 3992

wherein an external surface of the longitudinal opposed sidewall, the exterior surface of said transitional segment and an external surface of the ceiling comprises a blended contour.

Furthermore, Minesaki discloses the exposed opposed sidewalls (9) to the interior of the train car, the top curved portion/transitional wall portion at the junction between sidewall 9 and ceiling, and ceiling being combined into an integrated whole¹⁰ (see Figure 2).

With respect to the limitation of claims 17 and 18, Minesaki discloses

wherein the video signal source unit is configured to display a series of short messages in sequence on said plurality of video display monitors.
and

wherein the series of short messages comprise advertising content, said advertising content providing an additional source of revenue for the operator of the subway car.

Minesaki explicitly discloses the video signal source unit (control part G) providing information (guided to turnstiles, accident information, alternative modes of transportation, and advertisement information; pages 588, 590) to the monitors (see references to J on each side of sidewall 9 and ceiling interface in Figure 2).

Issue 12

21. Claims 15-18 are rejected under 35 U.S.C. 102(b) as being anticipated by Amano et al. (Japanese. Publication No. JP 02-23985 A).

With respect to the limitation of claim 15, Amano et al. discloses

¹⁰ "blend." Merriam-Webster Online Dictionary. 2012. Merriam-Webster Online. 10 April 2012
<<http://www.merriam-webster.com/dictionary/blend>>

Art Unit: 3992

A subway car for mass transportation

As shown in Figure 2, Amano et al. discloses train cars in which information is displayed during transit (train cars; page 651, column 2, lines 5-10, 28-33; page 653, column 1, lines 43-45; see Figures 4-6).

including longitudinal opposed sidewalls that further comprise a transitional segment and a ceiling adjoining the sidewalls with the transitional segment disposed at the junction of the sidewall and the ceiling,

In addition, Amano et al. discloses the train car including a pair of longitudinal opposed sidewalls (see Figures 4-6) with each sidewall having a top curved portion/transitional wall portion at the junction between sidewall and ceiling in Figures 4-6. Moreover, as is shown in Figure 4, the information signal display device **8** is positioned in the curved portion/transitional wall portion of the junction between the ceiling and the sidewall. Similarly, in Figures 5 and 6, the information signal display device **8** is positioned in the curved portion/transitional wall portion of the junction between the ceiling and the sidewall. Furthermore, Amano et al. discloses the portion of top angle/curved portion/transitional wall portion being directed/inclined downward towards the seat of the train car at an angle not including 90, 180 or 270 degrees (i.e. obliquely; see Figures 4-6). Similarly, Amano et al. discloses a top portion of the train car which is considered to be the ceiling which is right next to and connected to the sidewalls, accordingly (see Figures 4-6).

Art Unit: 3992

the subway car further comprising: a video display system comprising: a plurality of video display monitors each having a video screen; and a video signal source unit operatively connected to said video display monitors;

Amano et al. clearly discloses a video display system, in Figure 2, including a plurality of video display monitors (information signal display device **8a-8n**; see Figures 2, 4-6) with each having a video screen (**display**) as well as a video signal source unit (display information signal transmitter **7**) operatively connected to said video display monitors (information signal display device **8a-8n**; see Figures 2, 4-6).

wherein said video display monitors are spaced along the length of the car on opposing sides of the subway, each of the video display monitors being mounted within the transitional segment, with the video screen of each video display monitor being substantially contiguous with an exterior surface of said transitional segment, said video screen being directed obliquely downwardly toward the car seats so that each video screen is readily visible to passengers in the subway car.

With respect to the limitation of "*with the video screen of each video display monitor being substantially contiguous with an exterior surface of said transitional segment*" of claim 15, the examiner can find no explicit disclosure to each video display monitor being "substantially contiguous" or "contiguous" with an exterior surface of the transitional segment within the instant specification. The term "*contiguous*" is defined as "being in actual contact : touching along a boundary or at a point" or "touching or connected throughout in an unbroken sequence"¹¹. The examiner looks to the instant Patent specification to ascertain which definition would be comparable to the Owner's instant Patent disclosure.

Art Unit: 3992

As asserted above, the instant Patent specification discloses

An alternative embodiment is illustrated in FIG. 4A, a view similar to that of FIG. 4. In this alternative embodiment, CRT video monitor 22 is replaced with an LCD-based video monitor 22A which is of thin, rectangular cross-section, and occupies less space in the ceiling structure of the car. Accordingly, it can be moved towards the ceiling so that its viewing screen is substantially flush with or even behind the light panel 40. This use of an LCD-based monitor gives a better aesthetic appearance to the inside of the subway car as a whole, as well as improving the display performance by minimizing the interference effects, as previously discussed. (Page 5, lines 35-46).

Similarly, the instant Patent specification discloses

*The screens are preferably covered with a rigid transparent unit, e.g. of polycarbonate, shaped to coincide with the shape of the internal wall of the subway car at the location of mounting. For example, when the monitor is mounted at the junction of the wall and ceiling of the subway car, where there is commonly provided a concavely curved segment of internal wall, **the transparent cover unit is suitably similarly concavely curved, so that it can be mounted as a continuum with the internal walls and blended to contours thereof, with the monitor mounted behind it.** (Column 3, line64 – column 4, line 8; see Figure 6) and;*

*An alternative arrangement is shown in FIG. 6. Here **the polycarbonate shield 44 is convexly curved**, and is disposed further forward from the monitor screen 44. **The shield 44 now blends with forward facing part 48 the exterior skin and body structure 34**, to provide a perhaps more aesthetically appealing arrangement. (Column 5, lines 57-62)*

Again, as asserted above, the

“CRT video monitor is replaced with an LCD-based video monitor 22A which is of thin, rectangular cross-section, and occupies less space in the ceiling structure of the car”.

In Figure 4A above, Owner explicitly discloses the monitor 22A being behind the light panel 40 (see Figure 4A above). Owner alludes to the monitor 22A being “substantially flush”, however, never provides explicit disclosure of the embodiment.

¹¹ “contiguous.” Merriam-Webster Online Dictionary. 2012. Merriam-Webster Online. 10 April 2012

Art Unit: 3992

Moreover, after further examination of Figure 4A, the actual viewing screen of the monitor **22A** can never really be flush with the light panel since the screen of the monitor **22A** is further behind the transport screen **44A** of the appropriately shaped enclosure **42A**, hence there is an actual space and/or distance between the actual viewing screen of the monitor **22A** and the transport screen **44A** of the appropriately shaped enclosure **42A**. Furthermore, Owner never defines the term “flushed” and only alludes to the disclosure of “substantially flushed” in light of Figure 4A. Figure 4A clearly does not show the embodiment of the screen being “substantially flushed” with the adjacent wall surface structure and, additionally provides evidence to the fact that the screen of the display monitor can never have or form a continuous plane or unbroken surface¹² with the adjacent wall surface structure, but can only form a surface that is offset therefrom or “substantially flushed”, in light of the Owner's instant disclosure.

As asserted above, The term “*contiguous*” is defined as “being in actual contact : touching along a boundary or at a point” or “touching or connected throughout in an unbroken sequence”¹³. Since Owner discloses that the screen of the display monitor can never have or form a continuous plane or unbroken surface¹⁴ with the adjacent wall surface structure, but can only form a surface that is offset therefrom or “substantially flushed”, the term “substantially contiguous” can only be “*not wholly* in actual contact :

<<http://www.merriam-webster.com/dictionary/contiguous>>

¹² “flush.” Merriam-Webster Online Dictionary. 2012. Merriam-Webster Online. 10 April 2012

<<http://www.merriam-webster.com/dictionary/flush>>

¹³ “contiguous.” Merriam-Webster Online Dictionary. 2012. Merriam-Webster Online. 10 April 2012

<<http://www.merriam-webster.com/dictionary/contiguous>>

¹⁴ “flush.” Merriam-Webster Online Dictionary. 2012. Merriam-Webster Online. 10 April 2012

<<http://www.merriam-webster.com/dictionary/flush>>

Art Unit: 3992

touching along a boundary or at a point” or offset therefrom not “touching or connected throughout in an unbroken sequence”.

Therefore, the term “substantially contiguous” can only be deemed as “not wholly in actual contact : touching along a boundary or at a point” or a surface that is offset therefrom or “substantially flushed”, since the Owner has further not explicitly defined the term “contiguous” or any embodiment of the instant Patent having a video screen of each video display monitor being substantially contiguous with an exterior surface of the transitional segment, only to an embodiment of a video screen of each video display monitor being substantially flushed or a surface that is offset from an exterior surface of the transitional segment (see explanation above). Furthermore, any other interpretation of the term “substantially contiguous” not being “not wholly in actual contact : touching along a boundary or at a point” or “a surface that is offset therefrom” or “substantially flushed” would be deemed new matter since there is no explicit disclosure to any other embodiment.

Furthermore, Amano et al. discloses the monitors (information signal display device **8a-8n**; see Figures 2, 4-6) being positioned in the middle of the length of each sidewall opposite each other (see Figures 4-6) with the monitors (**8**) specifically being disposed within the top-curved region portion between the ceiling and sidewall (see Figures 4, 5) and the monitors (**8**) being further disposed within a portion of the top-curved region portion between the ceiling and sidewall **8** in another embodiment (see Figure 6). Such an arrangement of the monitors (information signal display device **8a-8n**) being disposed/mounted within the top-curved region portion between the ceiling

Art Unit: 3992

and sidewall (see Figures 4-6) would make each monitor (8) be "not wholly in actual contact with; or touching along a boundary or at a point"¹⁵ or "substantially contiguous" (i.e. **substantially flushed** or **a surface that is offset**, as set forth directly above) with the surface of the sidewall facing the interior of the subway car in order to allow the monitor (8), which is facing downward and lying in the top curved portion/transitional wall portion, to be directed/inclined downward towards the seat of the train car at an angle not including 90, 180 or 270 degrees (i.e. obliquely; see Figure 2) so that each video screen (**display**) is readily visible to passengers in the train car.

With respect to the limitation of claim 16, Amano et al. discloses

wherein an external surface of the longitudinal opposed sidewall, the exterior surface of said transitional segment and an external surface of the ceiling comprises a blended contour.

Furthermore, Amano et al. discloses the exposed opposed sidewalls to the interior of the train car, the top curved portion/transitional wall portion at the junction between sidewall and ceiling, and ceiling being combined into an integrated whole¹⁶ (see Figures 4-6).

With respect to the limitation of claims 17 and 18, Amano et al. discloses

wherein the video signal source unit is configured to display a series of short messages in sequence on said plurality of video display monitors.
and

¹⁵ "contiguous." Merriam-Webster Online Dictionary. 2012. Merriam-Webster Online. 10 April 2012 <<http://www.merriam-webster.com/dictionary/contiguous>>

¹⁶ "blend." Merriam-Webster Online Dictionary. 2012. Merriam-Webster Online. 10 April 2012 <<http://www.merriam-webster.com/dictionary/blend>>

Art Unit: 3992

wherein the series of short messages comprise advertising content, said advertising content providing an additional source of revenue for the operator of the subway car.

Amano et al. explicitly discloses the video signal source unit (display information signal transmitter 7) providing information (nonroutine information; advertisements; cultural information, event information, theme park information, etc.; Abstract; pages 651, 653) to the monitors (information signal display device 8a-8n).

Issue 13

22. Claims 15-18 are rejected under 35 U.S.C. 103(a) as being unpatentable over Maekawa et al. (Japanese. Publication No. JP 04-160991 A) in view of Amano et al. (Japanese. Publication No. JP 02-23985 A).

With respect to the limitation of claim 15, Maekawa et al. discloses

A subway car for mass transportation

As shown in Figure 2, Maekawa et al. discloses a car body of an electric train in which information is displayed during transit (car body of an electric train; page 738, column 2; see Figures 1, 2).

including longitudinal opposed sidewalls that further comprise a segment and a ceiling adjoining the sidewalls with the segment disposed at the junction of the sidewall and the ceiling,

In addition, Maekawa et al. discloses the train car including a pair of longitudinal opposed sidewalls (see Figures 1, 2) with each sidewall having a wall portion at the junction between sidewall and ceiling in Figure 2. Moreover, as is shown in Figure 2, the

Art Unit: 3992

monitor (101-124) is positioned on the sidewall of the train car. In addition, Maekawa et al. discloses the sidewalls meeting the transitional segment of the ceiling with the transitional segment disposed at the junction of the sidewall and the ceiling (see Figure 2). Similarly, Maekawa et al. discloses a top portion of the train car which is considered to be the ceiling which is right next to and connected to the sidewalls, accordingly (see Figure 2).

the subway car further comprising: a video display system comprising: a plurality of video display monitors each having a video screen; and a video signal source unit operatively connected to said video display monitors;

Maekawa et al. clearly discloses a video display system, in Figure 1, including a plurality of video display monitors (101-124; page 738, column 2; see Figures 1, 2) with each having a video screen (**display**) as well as a video signal source unit (see Figure 1) operatively connected to said video display monitors (101-124; page 738, column 2; see Figures 1, 2).

wherein said video display monitors are spaced along the length of the car on opposing sides of the subway.

Furthermore, Maekawa et al. discloses the monitors (101-124; page 738, column 2; see Figures 1, 2) being positioned in the middle of the length of each sidewall opposite each other (see Figures 1, 2) with the monitors (101-124; page 738, column 2; see Figures 1, 2) specifically being disposed on the sidewall of the train car (see Figure 2).

With respect to the limitation of claim 17, Maekawa et al. discloses

Art Unit: 3992

wherein the video signal source unit is configured to display a series of short messages in sequence on said plurality of video display monitors.
and

Maekawa et al. explicitly discloses the video signal source unit (see Figure 1) providing information (broadcast teletext information including short messages in sequence, etc.; and reproduced images; Abstract; pages 737-742) to the monitors (**101-124**; page 738, column 2; see Figures 1, 2).

Maekawa et al. discloses all of the limitations of the claimed invention, as previously set forth, except for specifically calling for the transitional segment/wall portion being part of the sidewalls; each of the monitors being disposed/mounted within the transitional wall portion at the junction of the sidewall and ceiling such that the video screen of the respective video display monitor substantially blends with the adjacent surface structure of the transitional wall portion, with the video screen of each video display monitor being substantially contiguous with an exterior surface of said transitional segment and being directed obliquely downwardly toward the car seats; an external surface of the longitudinal opposed sidewall, the exterior surface of said transitional segment and an external surface of the ceiling comprising a blended contour; and the series of short messages comprising advertising content with the advertising content providing an additional source of revenue for the operator of the subway car.

However, the transitional segment being part of the sidewalls and each of the monitors being mounted within the transitional wall portion at the junction of the sidewall and ceiling and directed obliquely downwardly toward the car seats is known in the art.

Art Unit: 3992

With respect to the limitation of “with the video screen of each video display monitor being **substantially contiguous** with an exterior surface of said transitional segment” of claim 15, the examiner can find no explicit disclosure to each video display monitor being “substantially contiguous” or “contiguous” with an exterior surface of the transitional segment within the instant specification. The term “contiguous” is defined as “being in actual contact : touching along a boundary or at a point” or “touching or connected throughout in an unbroken sequence”¹⁷. The examiner looks to the instant Patent specification to ascertain which definition would be comparable to the Owner’s instant Patent disclosure.

As asserted above, the instant Patent specification discloses

An alternative embodiment is illustrated in FIG. 4A, a view similar to that of FIG. 4. In this alternative embodiment, CRT video monitor 22 is replaced with an LCD-based video monitor 22A which is of thin, rectangular cross-section, and occupies less space in the ceiling structure of the car. Accordingly, it can be moved towards the ceiling so that its viewing screen is substantially flush with or even behind the light panel 40. This use of an LCD-based monitor gives a better aesthetic appearance to the inside of the subway car as a whole, as well as improving the display performance by minimizing the interference effects, as previously discussed. (Page 5, lines 35-46).

Similarly, the instant Patent specification discloses

The screens are preferably covered with a rigid transparent unit, e.g. of polycarbonate, shaped to coincide with the shape of the internal wall of the subway car at the location of mounting. For example, when the monitor is mounted at the junction of the wall and ceiling of the subway car, where there is commonly provided a concavely curved segment of internal wall, the transparent cover unit is suitably similarly concavely curved, so that it can be mounted as a continuum with the internal walls and blended to contours thereof, with the monitor mounted behind it. (Column 3, line64 – column 4, line 8; see Figure 6) and;

¹⁷ “contiguous.” Merriam-Webster Online Dictionary. 2012. Merriam-Webster Online. 10 April 2012 <<http://www.merriam-webster.com/dictionary/contiguous>>

Art Unit: 3992

*An alternative arrangement is shown in FIG. 6. Here **the polycarbonate shield 44 is convexly curved**, and is disposed further forward from the monitor screen 44. **The shield 44 now blends with forward facing part 48 the exterior skin and body structure 34**, to provide a perhaps more aesthetically appealing arrangement. (Column 5, lines 57-62)*

Again, as asserted above, the

"CRT video monitor is replaced with an LCD-based video monitor 22A which is of thin, rectangular cross-section, and occupies less space in the ceiling structure of the car".

In Figure 4A above, Owner explicitly discloses the monitor 22A being behind the light panel 40 (see Figure 4A above). Owner alludes to the monitor 22A being "substantially flush", however, never provides explicit disclosure of the embodiment. Moreover, after further examination of Figure 4A, the actual viewing screen of the monitor 22A can never really be flush with the light panel since the screen of the monitor 22A is further behind the transport screen 44A of the appropriately shaped enclosure 42A, hence there is an actual space and/or distance between the actual viewing screen of the monitor 22A and the transport screen 44A of the appropriately shaped enclosure 42A. Furthermore, Owner never defines the term "flushed" and only alludes to the disclosure of "substantially flushed" in light of Figure 4A. Figure 4A clearly does not show the embodiment of the screen being "substantially flushed" with the adjacent wall surface structure and, additionally provides evidence to the fact that the screen of the display monitor can never have or form a continuous plane or unbroken

Art Unit: 3992

surface¹⁸ with the adjacent wall surface structure, but can only form a surface that is offset therefrom or "substantially flushed", in light of the Owner's instant disclosure.

As asserted above, The term "*contiguous*" is defined as "being in actual contact : touching along a boundary or at a point" or "touching or connected throughout in an unbroken sequence"¹⁹. Since Owner discloses that the screen of the display monitor can never have or form a continuous plane or unbroken surface²⁰ with the adjacent wall surface structure, but can only form a surface that is offset therefrom or "substantially flushed", the term "substantially contiguous" can only be "*not wholly* in actual contact : touching along a boundary or at a point" or offset therefrom not "touching or connected throughout in an unbroken sequence".

Therefore, the term "substantially contiguous" can only be deemed as "*not wholly* in actual contact : touching along a boundary or at a point" or a surface that is offset therefrom or "substantially flushed", since the Owner has further not explicitly defined the term "contiguous" or any embodiment of the instant Patent having a video screen of each video display monitor being **substantially contiguous** with an exterior surface of the transitional segment, only to an embodiment of a video screen of each video display monitor being **substantially flushed** or **a surface that is offset from** an exterior surface of the transitional segment (see explanation above). Furthermore, any other interpretation of the term "substantially contiguous" not being "*not wholly* in actual

¹⁸ "flush." Merriam-Webster Online Dictionary. 2012. Merriam-Webster Online. 10 April 2012
<<http://www.merriam-webster.com/dictionary/flush>>

¹⁹ "contiguous." Merriam-Webster Online Dictionary. 2012. Merriam-Webster Online. 10 April 2012
<<http://www.merriam-webster.com/dictionary/contiguous>>

²⁰ "flush." Merriam-Webster Online Dictionary. 2012. Merriam-Webster Online. 10 April 2012
<<http://www.merriam-webster.com/dictionary/flush>>

Art Unit: 3992

contact : touching along a boundary or at a point” or “a surface that is offset therefrom” or “substantially flushed” would be deemed new matter since there is no explicit disclosure to any other embodiment.

In that light, Amano et al. teaches each of the monitors being mounted within the transitional wall portion at the junction of the sidewall and ceiling (see Figures 4-6) and directed obliquely downwardly toward the car seats (see Figures 4-6). Such an arrangement of the monitors (information signal display device **8a-8n**; see Figures 2, 4-6) being disposed within the top-curved region portion between the ceiling and sidewall (see Figures 4-6) would blend or combine the monitors into an integrated whole²¹ with the sidewall and the top curved portion/transitional wall portion at the junction between sidewall in order to allow the portion of the monitor (**8**) lying in the top curved portion/transitional wall portion to be directed/inclined downward towards the seat of the train car at an angle not including 90, 180 or 270 degrees (i.e. obliquely; see Figure 2) so that each video screen (**display**) is readily visible to passengers in the train car. Similarly, such an arrangement of the monitors (information signal display device **8a-8n**) being disposed/mounted within the top-curved region portion between the ceiling and sidewall (see Figures 4-6) would make each monitor (**8**) be “not wholly in actual contact with; or touching along a boundary or at a point”²² or “substantially contiguous” (i.e. substantially flushed or a surface that is offset, as set forth directly above) with the surface of the sidewall facing the interior of the subway car to allow the monitor (**8**)

²¹ “blend.” Merriam-Webster Online Dictionary. 2012. Merriam-Webster Online. 10 April 2012 <<http://www.merriam-webster.com/dictionary/blend>>

Art Unit: 3992

which is facing downward and lying in the top curved portion/transitional wall portion to be directed/inclined downward towards the seat of the train car at an angle not including 90, 180 or 270 degrees (i.e. obliquely; see Figure 2) so that each video screen (**display**) is readily visible to passengers in the train car. Furthermore, Amano et al. discloses the exposed opposed sidewalls to the interior of the train car, the top curved portion/transitional wall portion at the junction between sidewall and ceiling, and ceiling being combined into an integrated whole²³ (see Figures 4-6). Amano et al. further teaches such a configuration presents a means to provide the offering place for information in transportation equipment being used more effectively and sharpness being obtained, thereby increasing the information offering ability to passengers (English translation Abstract).

Similarly, a series of short messages comprising advertising content with the advertising content providing an additional source of revenue for the operator of the subway car is known in the art. Amano et al., for example, teaches the video signal source unit (display information signal transmitter 7) providing advertising content (nonroutine information; advertisements; cultural information, event information, theme park information, etc.; Abstract; pages 651, 653) to the monitors (information signal display device 8a-8n). Amano et al. further teaches such a configuration provides a means to reduce management time as well strengthening the power of information provides due to "promptness" and "newness" (page 653).

²² "contiguous." Merriam-Webster Online Dictionary. 2012. Merriam-Webster Online. 10 April 2012 <<http://www.merriam-webster.com/dictionary/contiguous>>

Art Unit: 3992

It would have been obvious to one of ordinary skill in the art at the time of the invention was made to modify the train car wall/ceiling junction and the mounting and screen direction orientation of the monitors of Maekawa et al. with each of the monitors being mounted within the transitional wall portion at the junction of the sidewall and ceiling and directed obliquely downwardly toward the car seats of Amano et al. in order to present a means to provide the offering place for information in transportation equipment being used more effectively and sharpness being obtained, thereby increasing the information offering ability to passengers. Similarly, it would have been obvious to one of ordinary skill in the art at the time of the invention was made to modify the short messages of Maekawa et al. with the series of short messages comprising advertising content of Amano et al. in order to provide a means to reduce management time as well strengthening the power of information provides due to "promptness" and "newness".

23. To the degree it can be argued that "Minesaki", "Amano et al.", "Maekawa et al." and/or "Shinagawa et al." do not disclose "the screen of the monitor substantially flushed or flushed with the adjacent wall surface structure of the car"; and "the video display monitor being substantially contiguous with an exterior surface of said transitional segment" given their broadest reasonable interpretation, the additional rejections are provided as set forth below:

²³ "blend." Merriam-Webster Online Dictionary. 2012. Merriam-Webster Online. 10 April 2012

Issue 14

24. Claims 15-18 are rejected under 35 U.S.C. 103(a) as being unpatentable over Minesaki (Japanese. Publication No. JP 63-125984 of Japanese Application No. JP 61-272668) in view of Moore et al. (U.S. Patent No. 3,480,727).

With respect to the limitation of claim 15, Minesaki discloses

A subway car for mass transportation

As shown in Figure 2, Minesaki discloses train cars in which information is displayed during transit (train cars; page 588, lines 6-10; page 590, lines 18-19).

including longitudinal opposed sidewalls that further comprise a transitional segment and a ceiling adjoining the sidewalls with the transitional segment disposed at the junction of the sidewall and the ceiling,

In addition, Minesaki discloses the train car including a pair of longitudinal opposed sidewalls (9) with each sidewall having a top curved portion/transitional wall portion at the junction between sidewall 9 and ceiling in Figure 2. Moreover, as is shown in Figure 2, Minesaki discloses a portion of top curved portion/transitional wall portion being directed/inclined downward towards the seat of the train car at an angle not including 90, 180 or 270 degrees (i.e. obliquely; see Figure 2). Similarly, Minesaki discloses a top portion of the train car which is considered to be the ceiling which is right next to and connected to the sidewalls 9, accordingly (see Figure 2).

Art Unit: 3992

the subway car further comprising: a video display system comprising: a plurality of video display monitors each having a video screen; and a video signal source unit operatively connected to said video display monitors;

Minesaki clearly discloses a video display system, in Figure 5, including a plurality of video display monitors (see references to **J** on each side of sidewall **9** and ceiling interface in Figure 2) with each having a video screen (**display**) as well as a video signal source unit (control part **G**) operatively connected to said video display monitors (see references to **J** on each side of sidewall **9** and ceiling interface in Figure 2 as well as Figure 1).

wherein said video display monitors are spaced along the length of the car on opposing sides of the subway, each of the video display monitors being mounted within the transitional segment, with the video screen of each video display monitor being directed obliquely downwardly toward the car seats so that each video screen is readily visible to passengers in the subway car.

Furthermore, Minesaki discloses the monitors (see references to **J** on each side of sidewall **9** and ceiling interface in Figure 2) being positioned in the middle of the length of each sidewall opposite each other (see Figure 2) with portions of the monitors (see references to **J** on each side of sidewall **9** and ceiling interface in Figure 2) being disposed/mounted within the top-curved region portion between the ceiling and sidewall **9** (see Figure 2). Such an arrangement of the monitors (see references to **J** on each side of sidewall **9** and ceiling interface in Figure 2) being disposed/mounted within the top-curved region portion between the ceiling and sidewall **9** (see Figure 2) would make each monitor (**J**) be offset from the surface of the sidewall **9** facing the interior of the subway car to allow the portion of the monitor (**J**) lying in the top curved

Art Unit: 3992

portion/transitional wall portion to be directed/inclined downward towards the seat of the train car at an angle not including 90, 180 or 270 degrees (i.e. obliquely; see Figure 2) so that each video screen (**display**) is readily visible to passengers in the train car.

With respect to the limitation of claim 16, Minesaki discloses

wherein an external surface of the longitudinal opposed sidewall, the exterior surface of said transitional segment and an external surface of the ceiling comprises a blended contour.

Furthermore, Minesaki discloses the exposed opposed sidewalls (9) to the interior of the train car, the top curved portion/transitional wall portion at the junction between sidewall 9 and ceiling, and ceiling being combined into an integrated whole²⁴ (see Figure 2).

With respect to the limitation of claims 17 and 18, Minesaki discloses

wherein the video signal source unit is configured to display a series of short messages in sequence on said plurality of video display monitors.
and

wherein the series of short messages comprise advertising content, said advertising content providing an additional source of revenue for the operator of the subway car.

Minesaki explicitly discloses the video signal source unit (control part G) providing information (guided to turnstiles, accident information, alternative modes of transportation, and advertisement information; pages 588, 590) to the monitors (see references to J on each side of sidewall 9 and ceiling interface in Figure 2).

²⁴ "blend." Merriam-Webster Online Dictionary. 2012. Merriam-Webster Online. 10 April 2012 <<http://www.merriam-webster.com/dictionary/blend>>

Art Unit: 3992

Minesaki discloses all of the limitations of the claimed invention, as previously set forth, except for specifically calling for the screen of the monitor being substantially flushed or substantially contiguous with the adjacent wall surface structure/exterior surface of a transitional segment; the video display monitor being flushed the adjacent wall structure such that it contains no protuberances; and the video display monitors being each enclosed within an enclosure.

With respect to the limitation of "*with the video screen of each video display monitor being **substantially contiguous** with an exterior surface of said transitional segment*" of claim 15, the examiner can find no explicit disclosure to each video display monitor being "substantially contiguous" or "contiguous" with an exterior surface of the transitional segment within the instant specification. The term "*contiguous*" is defined as "being in actual contact : touching along a boundary or at a point" or "touching or connected throughout in an unbroken sequence"²⁵. The examiner looks to the instant Patent specification to ascertain which definition would be comparable to the Owner's instant Patent disclosure.

As asserted above, the instant Patent specification discloses

An alternative embodiment is illustrated in FIG. 4A, a view similar to that of FIG. 4. In this alternative embodiment, CRT video monitor 22 is replaced with an LCD-based video monitor 22A which is of thin, rectangular cross-section, and occupies less space in the ceiling structure of the car. Accordingly, it can be moved towards the ceiling so that its viewing screen is substantially flush with or even behind the light panel 40. This use of an LCD-based monitor gives a better aesthetic appearance to the inside of the subway car as a whole, as well as improving the display performance by minimizing the interference effects, as previously discussed. (Page 5, lines 35-46).

²⁵ "contiguous." Merriam-Webster Online Dictionary. 2012. Merriam-Webster Online. 10 April 2012 <<http://www.merriam-webster.com/dictionary/contiguous>>

Art Unit: 3992

Similarly, the instant Patent specification discloses

*The screens are preferably covered with a rigid transparent unit, e.g. of polycarbonate, shaped to coincide with the shape of the internal wall of the subway car at the location of mounting. For example, when the monitor is mounted at the junction of the wall and ceiling of the subway car, where there is commonly provided a concavely curved segment of internal wall, **the transparent cover unit is suitably similarly concavely curved, so that it can be mounted as a continuum with the internal walls and blended to contours thereof, with the monitor mounted behind it.*** (Column 3, line 64 – column 4, line 8; see Figure 6) and;

*An alternative arrangement is shown in FIG. 6. Here **the polycarbonate shield 44 is convexly curved**, and is disposed further forward from the monitor screen 44. **The shield 44 now blends with forward facing part 48 the exterior skin and body structure 34**, to provide a perhaps more aesthetically appealing arrangement.* (Column 5, lines 57-62)

Again, as asserted above, the

*“CRT video monitor is replaced with an LCD-based video monitor **22A** which is of thin, rectangular cross-section, and occupies less space in the ceiling structure of the car”.*

In Figure 4A above, Owner explicitly discloses the monitor **22A** being behind the light panel **40** (see Figure 4A above). Owner alludes to the monitor **22A** being “substantially flush”, however, never provides explicit disclosure of the embodiment. Moreover, after further examination of Figure 4A, the actual viewing screen of the monitor **22A** can never really be flush with the light panel since the screen of the monitor **22A** is further behind the transport screen **44A** of the appropriately shaped enclosure **42A**, hence there is an actual space and/or distance between the actual viewing screen of the monitor **22A** and the transport screen **44A** of the appropriately shaped enclosure **42A**. Furthermore, Owner never defines the term “flushed” and only alludes to the disclosure of “substantially flushed” in light of Figure 4A. Figure 4A clearly

Art Unit: 3992

does not show the embodiment of the screen being "substantially flushed" with the adjacent wall surface structure and, additionally provides evidence to the fact that the screen of the display monitor can never have or form a continuous plane or unbroken surface²⁶ with the adjacent wall surface structure, but can only form a surface that is offset therefrom or "substantially flushed", in light of the Owner's instant disclosure.

As asserted above, The term "*contiguous*" is defined as "being in actual contact : touching along a boundary or at a point" or "touching or connected throughout in an unbroken sequence"²⁷. Since Owner discloses that the screen of the display monitor can never have or form a continuous plane or unbroken surface²⁸ with the adjacent wall surface structure, but can only form a surface that is offset therefrom or "substantially flushed", the term "substantially contiguous" can only be "*not wholly* in actual contact : touching along a boundary or at a point" or offset therefrom not "touching or connected throughout in an unbroken sequence".

Therefore, the term "substantially contiguous" can only be deemed as "*not wholly* in actual contact : touching along a boundary or at a point" or a surface that is offset therefrom or "substantially flushed", since the Owner has further not explicitly defined the term "contiguous" or any embodiment of the instant Patent having a video screen of each video display monitor being **substantially contiguous** with an exterior surface of the transitional segment, only to an embodiment of a video screen of each video display

²⁶ "flush." Merriam-Webster Online Dictionary. 2012. Merriam-Webster Online. 10 April 2012
<<http://www.merriam-webster.com/dictionary/flush>>

²⁷ "contiguous." Merriam-Webster Online Dictionary. 2012. Merriam-Webster Online. 10 April 2012
<<http://www.merriam-webster.com/dictionary/contiguous>>

²⁸ "flush." Merriam-Webster Online Dictionary. 2012. Merriam-Webster Online. 10 April 2012
<<http://www.merriam-webster.com/dictionary/flush>>

Art Unit: 3992

monitor being substantially flushed or a surface that is offset from an exterior surface of the transitional segment (see explanation above). Furthermore, any other interpretation of the term "substantially contiguous" not being "*not wholly* in actual contact : touching along a boundary or at a point" or "a surface that is offset therefrom" or "substantially flushed" would be deemed new matter since there is no explicit disclosure to any other embodiment.

In that light, screen of the monitor being substantially flushed or substantially contiguous with the adjacent wall surface structure/exterior surface of a transitional segment is known in the art. Moore et al., for example, teaches a screen of a monitor being substantially flushed with the adjacent wall surface structure as being an equivalent structure in the art (column 7, lines 41-44). Moreover, since the screen of the monitor is flushed with the adjacent wall surface structure, the video display monitor would additionally have to be "not wholly in actual contact with; or touching along a boundary or at a point"²⁹ or "substantially contiguous" with an exterior surface of the wall segment, as set forth above. Furthermore, since the screen of the monitor is flushed or forming a continuous plane or unbroken surface³⁰ with the adjacent wall, by shear definition the video display monitor/screen would have no protuberances. Moore et al. further teaches such a configuration provides a means to compensate for wall thickness or, the availability of space beyond the surface of the wall (column 7, lines 44-47).

²⁹ "contiguous." Merriam-Webster Online Dictionary. 2012. Merriam-Webster Online. 10 April 2012 <<http://www.merriam-webster.com/dictionary/contiguous>>

³⁰ "flush." Merriam-Webster Online Dictionary. 2012. Merriam-Webster Online. 10 April 2012 <<http://www.merriam-webster.com/dictionary/flush>>

Art Unit: 3992

Similarly, video display monitors being each enclosed within an enclosure is known in the art. Moore et al., for example, teach a video monitor system (see Figures 1, 2) which may have a plurality of monitors (column 7, lines 59-63) with each video display monitors being enclosed within an enclosure (frame members 162, 163, 165, etc. combination; column 6, lines 58-66; see Figures 1, 2). Moore et al. further teaches such a configuration provides a means to facilitate removal of the monitor for repair and/or service any elements of the monitor (column 2, lines 33-38; column 7, lines 32-40), thereby increasing the ease of operational maintenance of the monitors.

It would have been obvious to one of ordinary skill in the art at the time of the invention was made to modify each of the video display monitors of Minesaki with each of the video display monitors being enclosed within an enclosure of Moore et al. in order to provide a means to facilitate removal of the monitor for repair and/or service any elements of the monitor, thereby increasing the ease of operational maintenance of the monitors.

Similarly, it would have been obvious to one of ordinary skill in the art at the time of the invention was made to modify the monitor being projecting slightly beyond the adjacent wall surface structure of the car of Minesaki with the screen of the monitor being substantially flushed, substantially contiguous or flushed with the adjacent wall surface structure of Moore et al. in order to provide a means to compensate for wall thickness or, the availability of space beyond the surface of the wall. In addition, because these two monitor/wall configurations were art recognized equivalents at the

Art Unit: 3992

time the invention was made, one of ordinary skill in the art would have found it obvious to substitute a screen of the monitor being substantially flushed, substantially contiguous or flushed with the adjacent wall surface structure for a monitor being projecting slightly beyond the adjacent wall surface structure.

Moreover, the examiner asserts that applying a known technique to a known device ready for improvement would yield predictable results. That is, it would have been recognized by one of ordinary skill in the art that applying the known technique taught by Moore et al. to the subway car of Minesaki would have yielded predictable results and resulted in an improved system, namely, a screen of the monitor being substantially flushed, substantially contiguous or flushed with the adjacent wall surface structure for a monitor being projecting slightly beyond the adjacent wall surface structure in Minesaki to provide a means to compensate for wall thickness or, the availability of space beyond the surface of the wall.

Likewise, the examiner asserts that simple substitution of one known element for another would obtain predictable results. That is, the substitution of one known element (a screen of the monitor being substantially flushed, substantially contiguous or flushed with the adjacent wall surface structure as shown in Moore et al.) for another (a monitor being projecting slightly beyond the adjacent wall surface structure as shown in Moore et al. and Minesaki) would have been obvious to one of ordinary skill in the art at the time of the invention since the substitution of a screen of the monitor being substantially flushed, substantially contiguous or flushed with the adjacent wall surface structure in Minesaki would have yielded predictable results, namely, providing a screen of the

Art Unit: 3992

monitor being substantially flushed, substantially contiguous or flushed with the adjacent wall surface structure in Minesaki to provide a means to compensate for wall thickness or, the availability of space beyond the surface of the wall.

Furthermore, the examiner asserts use of known technique to improve similar devices in the same way is obvious to one of ordinary skill in the art. That is, the manner of enhancing a particular device (providing a screen of the monitor being substantially flushed, substantially contiguous or flushed with the adjacent wall surface structure) was made part of the ordinary capabilities of one skilled in the art based upon the teaching of such improvement in Moore et al. Accordingly, one of ordinary skill in the art would have been capable of applying this known "improvement" technique in the same manner to the prior art subway car of Minesaki and the results would have been predictable to one of ordinary skill in the art, namely, one skilled in the art would have readily recognized that providing a screen of the monitor being substantially flushed, substantially contiguous or flushed with the adjacent wall surface structure in Minesaki would positively provide a means to compensate for wall thickness or, the availability of space beyond the surface of the wall.

Issue 15

25. Claims 15-18 are rejected under 35 U.S.C. 103(a) as being unpatentable over Amano et al. (Japanese. Publication No. JP 02-23985 A) in view of Moore et al. (U.S. Patent No. 3,480,727).

With respect to the limitation of claim 15, Amano et al. discloses

A subway car for mass transportation

As shown in Figure 2, Amano et al. discloses train cars in which information is displayed during transit (train cars; page 651, column 2, lines 5-10, 28-33; page 653, column 1, lines 43-45; see Figures 4-6).

including longitudinal opposed sidewalls that further comprise a transitional segment and a ceiling adjoining the sidewalls with the transitional segment disposed at the junction of the sidewall and the ceiling,

In addition, Amano et al. discloses the train car including a pair of longitudinal opposed sidewalls (see Figures 4-6) with each sidewall having a top curved portion/transitional wall portion at the junction between sidewall and ceiling in Figures 4-6. Moreover, as is shown in Figure 4, the information signal display device 8 is positioned in the curved portion/transitional wall portion of the junction between the ceiling and the sidewall. Similarly, in Figures 5 and 6, the information signal display device 8 is positioned in the curved portion/transitional wall portion of the junction between the ceiling and the sidewall. Furthermore, Amano et al. discloses the portion of top angle/curved portion/transitional wall portion being directed/inclined downward towards the seat of the train car at an angle not including 90, 180 or 270 degrees (i.e. obliquely; see Figures 4-6). Similarly, Amano et al. discloses a top portion of the train car which is considered to be the ceiling which is right next to and connected to the sidewalls, accordingly (see Figures 4-6).

Art Unit: 3992

the subway car further comprising: a video display system comprising: a plurality of video display monitors each having a video screen; and a video signal source unit operatively connected to said video display monitors;

Amano et al. clearly discloses a video display system, in Figure 2, including a plurality of video display monitors (information signal display device **8a-8n**; see Figures 2, 4-6) with each having a video screen (**display**) as well as a video signal source unit (display information signal transmitter **7**) operatively connected to said video display monitors (information signal display device **8a-8n**; see Figures 2, 4-6).

wherein said video display monitors are spaced along the length of the car on opposing sides of the subway, each of the video display monitors being mounted within the transitional segment, with the video screen of each video display monitor being directed obliquely downwardly toward the car seats so that each video screen is readily visible to passengers in the subway car.

Furthermore, Amano et al. discloses the monitors (information signal display device **8a-8n**; see Figures 2, 4-6) being positioned in the middle of the length of each sidewall opposite each other (see Figures 4-6) with the monitors (**8**) specifically being disposed within the top-curved region portion between the ceiling and sidewall (see Figures 4, 5) and the monitors (**8**) being further disposed within a portion of the top-curved region portion between the ceiling and sidewall in another embodiment (see Figure 6). Such an arrangement of the monitors (information signal display device **8a-8n**) being disposed/mounted within the top-curved region portion between the ceiling and sidewall (see Figures 4-6) would make each monitor (**8**) be offset from the surface of the sidewall facing the interior of the subway car in order to allow the monitor (**8**) which is facing downward and lying in the top curved portion/transitional wall portion to

Art Unit: 3992

be directed/inclined downward towards the seat of the train car at an angle not including 90, 180 or 270 degrees (i.e. obliquely; see Figure 2) so that each video screen (**display**) is readily visible to passengers in the train car.

With respect to the limitation of claim 16, Amano et al. discloses

wherein an external surface of the longitudinal opposed sidewall, the exterior surface of said transitional segment and an external surface of the ceiling comprises a blended contour.

Furthermore, Amano et al. discloses the exposed opposed sidewalls to the interior of the train car, the top curved portion/transitional wall portion at the junction between sidewall and ceiling, and ceiling being combined into an integrated whole³¹ (see Figures 4-6).

With respect to the limitation of claims 17 and 18, Amano et al. discloses

wherein the video signal source unit is configured to display a series of short messages in sequence on said plurality of video display monitors.
and

wherein the series of short messages comprise advertising content, said advertising content providing an additional source of revenue for the operator of the subway car.

Amano et al. explicitly discloses the video signal source unit (display information signal transmitter 7) providing information (nonroutine information; advertisements; cultural information, event information, theme park information, etc.; Abstract; pages 651, 653) to the monitors (information signal display device **8a-8n**).

³¹ "blend." Merriam-Webster Online Dictionary. 2012. Merriam-Webster Online. 10 April 2012 <<http://www.merriam-webster.com/dictionary/blend>>

Art Unit: 3992

Amano et al. discloses all of the limitations of the claimed invention, as previously set forth, except for specifically calling for the screen of the monitor being the monitor being substantially flushed or substantially contiguous with the adjacent wall surface structure/exterior surface of a transitional segment; the video display monitor being flushed the adjacent wall structure such that it contains no protuberances; and the video display monitors being each enclosed within an enclosure.

With respect to the limitation of "*with the video screen of each video display monitor being **substantially contiguous** with an exterior surface of said transitional segment*" of claim 15, the examiner can find no explicit disclosure to each video display monitor being "substantially contiguous" or "contiguous" with an exterior surface of the transitional segment within the instant specification. The term "*contiguous*" is defined as "being in actual contact : touching along a boundary or at a point" or "touching or connected throughout in an unbroken sequence"³². The examiner looks to the instant Patent specification to ascertain which definition would be comparable to the Owner's instant Patent disclosure.

As asserted above, the instant Patent specification discloses

An alternative embodiment is illustrated in FIG. 4A, a view similar to that of FIG. 4. In this alternative embodiment, CRT video monitor 22 is replaced with an LCD-based video monitor 22A which is of thin, rectangular cross-section, and occupies less space in the ceiling structure of the car. Accordingly, it can be moved towards the ceiling so that its viewing screen is substantially flush with or even behind the light panel 40. This use of an LCD-based monitor gives a better aesthetic appearance to the inside of the subway car as a whole, as well as improving the display performance by minimizing the interference effects, as previously discussed. (Page 5, lines 35-46).

³² "contiguous." Merriam-Webster Online Dictionary. 2012. Merriam-Webster Online. 10 April 2012 <<http://www.merriam-webster.com/dictionary/contiguous>>

Art Unit: 3992

Similarly, the instant Patent specification discloses

*The screens are preferably covered with a rigid transparent unit, e.g. of polycarbonate, shaped to coincide with the shape of the internal wall of the subway car at the location of mounting. For example, when the monitor is mounted at the junction of the wall and ceiling of the subway car, where there is commonly provided a concavely curved segment of internal wall, **the transparent cover unit is suitably similarly concavely curved, so that it can be mounted as a continuum with the internal walls and blended to contours thereof, with the monitor mounted behind it.*** (Column 3, line 64 – column 4, line 8; see Figure 6) and;

*An alternative arrangement is shown in FIG. 6. Here **the polycarbonate shield 44 is convexly curved**, and is disposed further forward from the monitor screen 44. **The shield 44 now blends with forward facing part 48 the exterior skin and body structure 34**, to provide a perhaps more aesthetically appealing arrangement.* (Column 5, lines 57-62)

Again, as asserted above, the

*“CRT video monitor is replaced with an LCD-based video monitor **22A** which is of thin, rectangular cross-section, and occupies less space in the ceiling structure of the car”.*

In Figure 4A above, Owner explicitly discloses the monitor **22A** being behind the light panel **40** (see Figure 4A above). Owner alludes to the monitor **22A** being “substantially flush”, however, never provides explicit disclosure of the embodiment. Moreover, after further examination of Figure 4A, the actual viewing screen of the monitor **22A** can never really be flush with the light panel since the screen of the monitor **22A** is further behind the transport screen **44A** of the appropriately shaped enclosure **42A**, hence there is an actual space and/or distance between the actual viewing screen of the monitor **22A** and the transport screen **44A** of the appropriately shaped enclosure **42A**. Furthermore, Owner never defines the term “flushed” and only alludes to the disclosure of “substantially flushed” in light of Figure 4A. Figure 4A clearly

Art Unit: 3992

does not show the embodiment of the screen being "substantially flushed" with the adjacent wall surface structure and, additionally provides evidence to the fact that the screen of the display monitor can never have or form a continuous plane or unbroken surface³³ with the adjacent wall surface structure, but can only form a surface that is offset therefrom or "substantially flushed", in light of the Owner's instant disclosure.

As asserted above, The term "*contiguous*" is defined as "being in actual contact : touching along a boundary or at a point" or "touching or connected throughout in an unbroken sequence"³⁴. Since Owner discloses that the screen of the display monitor can never have or form a continuous plane or unbroken surface³⁵ with the adjacent wall surface structure, but can only form a surface that is offset therefrom or "substantially flushed", the term "substantially contiguous" can only be "*not wholly* in actual contact : touching along a boundary or at a point" or offset therefrom not "touching or connected throughout in an unbroken sequence".

Therefore, the term "substantially contiguous" can only be deemed as "*not wholly* in actual contact : touching along a boundary or at a point" or a surface that is offset therefrom or "substantially flushed", since the Owner has further not explicitly defined the term "contiguous" or any embodiment of the instant Patent having a video screen of each video display monitor being **substantially contiguous** with an exterior surface of the transitional segment, only to an embodiment of a video screen of each video display

³³ "flush." Merriam-Webster Online Dictionary. 2012. Merriam-Webster Online. 10 April 2012
<<http://www.merriam-webster.com/dictionary/flush>>

³⁴ "contiguous." Merriam-Webster Online Dictionary. 2012. Merriam-Webster Online. 10 April 2012
<<http://www.merriam-webster.com/dictionary/contiguous>>

³⁵ "flush." Merriam-Webster Online Dictionary. 2012. Merriam-Webster Online. 10 April 2012
<<http://www.merriam-webster.com/dictionary/flush>>

Art Unit: 3992

monitor being **substantially flushed** or **a surface that is offset from** an exterior surface of the transitional segment (see explanation above). Furthermore, any other interpretation of the term "substantially contiguous" not being "*not wholly* in actual contact : touching along a boundary or at a point" or "a surface that is offset therefrom" or "substantially flushed" would be deemed new matter since there is no explicit disclosure to any other embodiment.

In that light, screen of the monitor being substantially flushed or substantially contiguous with the adjacent wall surface structure/exterior surface of a transitional segment is known in the art. Moore et al., for example, teaches a screen of a monitor being substantially flushed with the adjacent wall surface structure as being an equivalent structure in the art (column 7, lines 41-44). Moreover, since the screen of the monitor is flushed with the adjacent wall surface structure, the video display monitor would additionally have to be "not wholly in actual contact with; or touching along a boundary or at a point"³⁶ or "substantially contiguous" with an exterior surface of the wall segment, as set forth above. Furthermore, since the screen of the monitor is flushed or forming a continuous plane or unbroken surface³⁷ with the adjacent wall, by shear definition the video display monitor/screen would have no protuberances. Moore et al. further teaches such a configuration provides a means to compensate for wall thickness or, the availability of space beyond the surface of the wall (column 7, lines 44-47).

³⁶ "contiguous." Merriam-Webster Online Dictionary. 2012. Merriam-Webster Online. 10 April 2012 <<http://www.merriam-webster.com/dictionary/contiguous>>

³⁷ "flush." Merriam-Webster Online Dictionary. 2012. Merriam-Webster Online. 10 April 2012 <<http://www.merriam-webster.com/dictionary/flush>>

³⁷

Art Unit: 3992

Similarly, video display monitors being each enclosed within an enclosure is known in the art. Moore et al., for example, teach a video monitor system (see Figures 1, 2) which may have a plurality of monitors (column 7, lines 59-63) with each video display monitors being enclosed within an enclosure (frame members **162, 163, 165**, etc. combination; column 6, lines 58-66; see Figures 1, 2). Moore et al. further teaches such a configuration provides a means to facilitate removal of the monitor for repair and/or service any elements of the monitor (column 2, lines 33-38; column 7, lines 32-40), thereby increasing the ease of operational maintenance of the monitors.

It would have been obvious to one of ordinary skill in the art at the time of the invention was made to modify each of the video display monitors of Amano et al. with each of the video display monitors being enclosed within an enclosure of Moore et al. in order to provide a means to facilitate removal of the monitor for repair and/or service any elements of the monitor, thereby increasing the ease of operational maintenance of the monitors.

Similarly, it would have been obvious to one of ordinary skill in the art at the time of the invention was made to modify the monitor being projecting slightly beyond the adjacent wall surface structure of the car of Amano et al. with the screen of the monitor being substantially flushed, substantially contiguous or flushed with the adjacent wall surface structure of Moore et al. in order to provide a means to compensate for wall thickness or, the availability of space beyond the surface of the wall. In addition, because these two monitor/wall configurations were art recognized equivalents at the

Art Unit: 3992

time the invention was made, one of ordinary skill in the art would have found it obvious to substitute a screen of the monitor being substantially flushed, substantially contiguous or flushed with the adjacent wall surface structure for a monitor being projecting slightly beyond the adjacent wall surface structure.

Moreover, the examiner asserts that applying a known technique to a known device ready for improvement would yield predictable results. That is, it would have been recognized by one of ordinary skill in the art that applying the known technique taught by Moore et al. to the subway car of Amano et al. would have yielded predictable results and resulted in an improved system, namely, a screen of the monitor being substantially flushed, substantially contiguous or flushed with the adjacent wall surface structure for a monitor being projecting slightly beyond the adjacent wall surface structure in Amano et al. to provide a means to compensate for wall thickness or, the availability of space beyond the surface of the wall.

Likewise, the examiner asserts that simple substitution of one known element for another would obtain predictable results. That is, the substitution of one known element (a screen of the monitor being substantially flushed, substantially contiguous or flushed with the adjacent wall surface structure as shown in Moore et al.) for another (a monitor being projecting slightly beyond the adjacent wall surface structure as shown in Moore et al. and Amano et al.) would have been obvious to one of ordinary skill in the art at the time of the invention since the substitution of a screen of the monitor being substantially flushed, substantially contiguous or flushed with the adjacent wall surface structure in Amano et al. would have yielded predictable results, namely, providing a screen of the

Art Unit: 3992

monitor being substantially flushed, substantially contiguous or flushed with the adjacent wall surface structure in Amano et al. to provide a means to compensate for wall thickness or, the availability of space beyond the surface of the wall.

Furthermore, the examiner asserts use of known technique to improve similar devices in the same way is obvious to one of ordinary skill in the art. That is, the manner of enhancing a particular device (providing a screen of the monitor being substantially flushed, substantially contiguous or flushed with the adjacent wall surface structure) was made part of the ordinary capabilities of one skilled in the art based upon the teaching of such improvement in Moore et al. Accordingly, one of ordinary skill in the art would have been capable of applying this known "improvement" technique in the same manner to the prior art subway car of Amano et al. and the results would have been predictable to one of ordinary skill in the art, namely, one skilled in the art would have readily recognized that providing a screen of the monitor being substantially flushed, substantially contiguous or flushed with the adjacent wall surface structure in Amano et al. would positively provide a means to compensate for wall thickness or, the availability of space beyond the surface of the wall.

Issue 16

26. Claims 15-18 are rejected under 35 U.S.C. 103(a) as being unpatentable over Maekawa et al. (Japanese. Publication No. JP 04-160991 A) in view of Amano et al. (Japanese. Publication No. JP 02-23985 A) and Moore et al. (U.S. Patent No. 3,480,727).

Art Unit: 3992

With respect to the limitation of claim 15, Maekawa et al. discloses

A subway car for mass transportation

As shown in Figure 2, Maekawa et al. discloses a car body of an electric train in which information is displayed during transit (car body of an electric train; page 738, column 2; see Figures 1, 2).

including longitudinal opposed sidewalls that further comprise a segment and a ceiling adjoining the sidewalls with the segment disposed at the junction of the sidewall and the ceiling,

In addition, Maekawa et al. discloses the train car including a pair of longitudinal opposed sidewalls (see Figures 1, 2) with each sidewall having a wall portion at the junction between sidewall and ceiling in Figure 2. Moreover, as is shown in Figure 2, the information signal display device (101-124) is positioned on the sidewall of the train car. In addition, Maekawa et al. discloses the sidewalls meeting the transitional segment of the ceiling with the transitional segment disposed at the junction of the sidewall and the ceiling (see Figure 2). Similarly, Maekawa et al. discloses a top portion of the train car which is considered to be the ceiling which is right next to and connected to the sidewalls, accordingly (see Figure 2).

the subway car further comprising: a video display system comprising: a plurality of video display monitors each having a video screen; and a video signal source unit operatively connected to said video display monitors;

Maekawa et al. clearly discloses a video display system, in Figure 1, including a plurality of video display monitors (101-124; page 738, column 2; see Figures 1, 2) with each having a video screen (**display**) as well as a video signal source unit (see Figure

Art Unit: 3992

1) operatively connected to said video display monitors (101-124; page 738, column 2; see Figures 1, 2).

wherein said video display monitors are spaced along the length of the car on opposing sides of the subway.

Furthermore, Maekawa et al. discloses the monitors (101-124; page 738, column 2; see Figures 1, 2) being positioned in the middle of the length of each sidewall opposite each other (see Figures 1, 2) with the monitors (101-124) specifically being disposed on the sidewall of the train car (see Figure 2).

With respect to the limitation of claim 17, Maekawa et al. discloses

wherein the video signal source unit is configured to display a series of short messages in sequence on said plurality of video display monitors.
and

Maekawa et al. explicitly discloses the video signal source unit (see Figure 1) providing information (broadcast teletext information including short messages in sequence, etc.; and reproduced images; Abstract; pages 737-742) to the monitors (101-124; page 738, column 2; see Figures 1, 2).

Maekawa et al. discloses all of the limitations of the claimed invention, as previously set forth, except for specifically calling for the transitional segment/wall portion being part of the sidewalls; each of the monitors being disposed/mounted within the transitional wall portion at the junction of the sidewall and ceiling such that the video screen of the respective video display monitor is substantially contiguous with the adjacent surface structure of the transitional wall portion and being directed obliquely downwardly toward the car seats; an external surface of the longitudinal opposed

Art Unit: 3992

sidewall, the exterior surface of said transitional segment and an external surface of the ceiling comprising a blended contour; the screen of the monitor being substantially flushed/blended or flushed with the adjacent wall surface structure instead of the monitor being projecting slightly beyond the adjacent wall surface structure; the series of short messages comprising advertising content, the advertising content providing an additional source of revenue for the operator of the subway car; and the video display monitors being each enclosed within an enclosure.

However, the transitional segment being part of the sidewalls and each of the monitors being mounted within the transitional wall portion at the junction of the sidewall and ceiling and directed obliquely downwardly toward the car seats is known in the art. Amano et al., for example, teaches each of the monitors being mounted within the transitional wall portion at the junction of the sidewall and ceiling (see Figures 4-6) and directed obliquely downwardly toward the car seats (see Figures 4-6). Such an arrangement of the monitors (information signal display device **8a-8n**; see Figures 2, 4-6) being disposed within the top-curved region portion between the ceiling and sidewall (see Figures 4-6) would blend or combine the monitors into an integrated whole³⁸ with the sidewall and the top curved portion/transitional wall portion at the junction between sidewall in order to allow the portion of the monitor (**8**) lying in the top curved portion/transitional wall portion to be directed/inclined downward towards the seat of the train car at an angle not including 90, 180 or 270 degrees (i.e. obliquely; see Figure 2) so that each video screen (**display**) is readily visible to passengers in the train car.

Art Unit: 3992

Similarly, such an arrangement of the monitors (information signal display device **8a-8n**) being disposed/mounted within the top-curved region portion between the ceiling and sidewall (see Figures 4-6) would make each monitor (**8**) be offset from the surface of the sidewall facing the interior of the subway car to allow the monitor (**8**) which is facing downward and lying in the top curved portion/transitional wall portion to be directed/inclined downward towards the seat of the train car at an angle not including 90, 180 or 270 degrees (i.e. obliquely; see Figure 2) so that each video screen (**display**) is readily visible to passengers in the train car. Furthermore, Amano et al. discloses the exposed opposed sidewalls to the interior of the train car, the top curved portion/transitional wall portion at the junction between sidewall and ceiling, and ceiling being combined into an integrated whole³⁹ (see Figures 4-6). Amano et al. further teaches such a configuration presents a means to provide the offering place for information in transportation equipment being used more effectively and sharpness being obtained, thereby increasing the information offering ability to passengers (English translation Abstract).

Similarly, a series of short messages comprising advertising content with the advertising content providing an additional source of revenue for the operator of the subway car is known in the art. Amano et al., for example, teaches the video signal source unit (display information signal transmitter **7**) providing advertising content (nonroutine information; advertisements; cultural information, event information, theme

³⁸ "blend." Merriam-Webster Online Dictionary. 2012. Merriam-Webster Online. 10 April 2012 <<http://www.merriam-webster.com/dictionary/blend>>

Art Unit: 3992

park information, etc.; Abstract; pages 651, 653) to the monitors (information signal display device **8a-8n**). Amano et al. further teaches such a configuration provides a means to reduce management time as well as strengthening the power of information provided due to "promptness" and "newness" (page 653).

With respect to the limitation of "*with the video screen of each video display monitor being **substantially contiguous** with an exterior surface of said transitional segment*" of claim 15, the examiner can find no explicit disclosure to each video display monitor being "substantially contiguous" or "contiguous" with an exterior surface of the transitional segment within the instant specification. The term "*contiguous*" is defined as "being in actual contact : touching along a boundary or at a point" or "touching or connected throughout in an unbroken sequence"⁴⁰. The examiner looks to the instant Patent specification to ascertain which definition would be comparable to the Owner's instant Patent disclosure.

As asserted above, the instant Patent specification discloses

An alternative embodiment is illustrated in FIG. 4A, a view similar to that of FIG. 4. In this alternative embodiment, CRT video monitor 22 is replaced with an LCD-based video monitor 22A which is of thin, rectangular cross-section, and occupies less space in the ceiling structure of the car. Accordingly, it can be moved towards the ceiling so that its viewing screen is substantially flush with or even behind the light panel 40. This use of an LCD-based monitor gives a better aesthetic appearance to the inside of the subway car as a whole, as well as improving the display performance by minimizing the interference effects, as previously discussed. (Page 5, lines 35-46).

Similarly, the instant Patent specification discloses

³⁹ "blend." Merriam-Webster Online Dictionary. 2012. Merriam-Webster Online. 10 April 2012
<<http://www.merriam-webster.com/dictionary/blend>>

⁴⁰ "contiguous." Merriam-Webster Online Dictionary. 2012. Merriam-Webster Online. 10 April 2012
<<http://www.merriam-webster.com/dictionary/contiguous>>

Art Unit: 3992

The screens are preferably covered with a rigid transparent unit, e.g. of polycarbonate, shaped to coincide with the shape of the internal wall of the subway car at the location of mounting. For example, when the monitor is mounted at the junction of the wall and ceiling of the subway car, where there is commonly provided a concavely curved segment of internal wall, the transparent cover unit is suitably similarly concavely curved, so that it can be mounted as a continuum with the internal walls and blended to contours thereof, with the monitor mounted behind it. (Column 3, line 64 – column 4, line 8; see Figure 6) and;

An alternative arrangement is shown in FIG. 6. Here the polycarbonate shield 44 is convexly curved, and is disposed further forward from the monitor screen 44. The shield 44 now blends with forward facing part 48 the exterior skin and body structure 34, to provide a perhaps more aesthetically appealing arrangement. (Column 5, lines 57-62)

Again, as asserted above, the

“CRT video monitor is replaced with an LCD-based video monitor 22A which is of thin, rectangular cross-section, and occupies less space in the ceiling structure of the car”.

In Figure 4A above, Owner explicitly discloses the monitor 22A being behind the light panel 40 (see Figure 4A above). Owner alludes to the monitor 22A being “substantially flush”, however, never provides explicit disclosure of the embodiment. Moreover, after further examination of Figure 4A, the actual viewing screen of the monitor 22A can never really be flush with the light panel since the screen of the monitor 22A is further behind the transport screen 44A of the appropriately shaped enclosure 42A, hence there is an actual space and/or distance between the actual viewing screen of the monitor 22A and the transport screen 44A of the appropriately shaped enclosure 42A. Furthermore, Owner never defines the term “flushed” and only alludes to the disclosure of “substantially flushed” in light of Figure 4A. Figure 4A clearly does not show the embodiment of the screen being “substantially flushed” with the

Art Unit: 3992

adjacent wall surface structure and, additionally provides evidence to the fact that the screen of the display monitor can never have or form a continuous plane or unbroken surface⁴¹ with the adjacent wall surface structure, but can only form a surface that is offset therefrom or "substantially flushed", in light of the Owner's instant disclosure.

As asserted above, The term "*contiguous*" is defined as "being in actual contact : touching along a boundary or at a point" or "touching or connected throughout in an unbroken sequence"⁴². Since Owner discloses that the screen of the display monitor can never have or form a continuous plane or unbroken surface⁴³ with the adjacent wall surface structure, but can only form a surface that is offset therefrom or "substantially flushed", the term "substantially contiguous" can only be "*not wholly* in actual contact : touching along a boundary or at a point" or offset therefrom not "touching or connected throughout in an unbroken sequence".

Therefore, the term "substantially contiguous" can only be deemed as "*not wholly* in actual contact : touching along a boundary or at a point" or a surface that is offset therefrom or "substantially flushed", since the Owner has further not explicitly defined the term "contiguous" or any embodiment of the instant Patent having a video screen of each video display monitor being **substantially contiguous** with an exterior surface of the transitional segment, only to an embodiment of a video screen of each video display monitor being **substantially flushed** or **a surface that is offset from** an exterior

⁴¹ "flush." Merriam-Webster Online Dictionary. 2012. Merriam-Webster Online. 10 April 2012
<<http://www.merriam-webster.com/dictionary/flush>>

⁴² "contiguous." Merriam-Webster Online Dictionary. 2012. Merriam-Webster Online. 10 April 2012
<<http://www.merriam-webster.com/dictionary/contiguous>>

⁴³ "flush." Merriam-Webster Online Dictionary. 2012. Merriam-Webster Online. 10 April 2012
<<http://www.merriam-webster.com/dictionary/flush>>

Art Unit: 3992

surface of the transitional segment (see explanation above). Furthermore, any other interpretation of the term "substantially contiguous" not being "*not wholly* in actual contact : touching along a boundary or at a point" or "a surface that is offset therefrom" or "substantially flushed" would be deemed new matter since there is no explicit disclosure to any other embodiment.

In that light, screen of the monitor being substantially flushed or substantially contiguous with the adjacent wall surface structure/exterior surface of a transitional segment is known in the art. Moore et al., for example, teaches a screen of a monitor being substantially flushed with the adjacent wall surface structure as being an equivalent structure in the art (column 7, lines 41-44). Moreover, since the screen of the monitor is flushed with the adjacent wall surface structure, the video display monitor would additionally have to be "not wholly in actual contact with; or touching along a boundary or at a point"⁴⁴ or "substantially contiguous" with an exterior surface of the wall segment, as set forth above. Furthermore, since the screen of the monitor is flushed or forming a continuous plane or unbroken surface⁴⁵ with the adjacent wall, by shear definition the video display monitor/screen would have no protuberances. Moore et al. further teaches such a configuration provides a means to compensate for wall thickness or, the availability of space beyond the surface of the wall (column 7, lines 44-47).

⁴⁴ "contiguous." Merriam-Webster Online Dictionary. 2012. Merriam-Webster Online. 10 April 2012 <<http://www.merriam-webster.com/dictionary/contiguous>>

⁴⁵ "flush." Merriam-Webster Online Dictionary. 2012. Merriam-Webster Online. 10 April 2012 <<http://www.merriam-webster.com/dictionary/flush>>

⁴⁵

Art Unit: 3992

Likewise, video display monitors being each enclosed within an enclosure is known in the art. Moore et al., for example, teach a video monitor system (see Figures 1, 2) which may have a plurality of monitors (column 7, lines 59-63) with each video display monitors being enclosed within an enclosure (frame members 162, 163, 165, etc. combination; column 6, lines 58-66; see Figures 1, 2). Moore et al. further teaches such a configuration provides a means to facilitate removal of the monitor for repair and/or service any elements of the monitor (column 2, lines 33-38; column 7, lines 32-40), thereby increasing the ease of operational maintenance of the monitors.

It would have been obvious to one of ordinary skill in the art at the time of the invention was made to modify the train car wall/ceiling junction and the mounting and screen direction orientation of the monitors of Maekawa et al. with each of the monitors being mounted within the transitional wall portion at the junction of the sidewall and ceiling and directed obliquely downwardly toward the car seats of Amano et al. in order to present a means to provide the offering place for information in transportation equipment being used more effectively and sharpness being obtained, thereby increasing the information offering ability to passengers. Similarly, it would have been obvious to one of ordinary skill in the art at the time of the invention was made to modify the short messages of Maekawa et al. with the series of short messages comprising advertising content of Amano et al. in order to provide a means to reduce management time as well as strengthening the power of information provided due to "promptness" and "newness".

Art Unit: 3992

Likewise, it would have been obvious to one of ordinary skill in the art at the time of the invention was made to modify each of the video display monitors of Maekawa et al. in view of Amano et al. with each of the video display monitors being enclosed within an enclosure of Moore et al. in order to provide a means to facilitate removal of the monitor for repair and/or service any elements of the monitor, thereby increasing the ease of operational maintenance of the monitors.

Moreover, it would have been obvious to one of ordinary skill in the art at the time of the invention was made to modify the monitor being projecting slightly beyond the adjacent wall surface structure of the car of Maekawa et al. in view of Amano et al. with the screen of the monitor being substantially flushed, substantially contiguous or flushed with the adjacent wall surface structure of Moore et al. in order to provide a means to compensate for wall thickness or, the availability of space beyond the surface of the wall. In addition, because these two monitor/wall configurations were art recognized equivalents at the time the invention was made, one of ordinary skill in the art would have found it obvious to substitute a screen of the monitor being substantially flushed, substantially contiguous or flushed with the adjacent wall surface structure for a monitor being projecting slightly beyond the adjacent wall surface structure.

In addition, the examiner asserts that applying a known technique to a known device ready for improvement would yield predictable results. That is, it would have been recognized by one of ordinary skill in the art that applying the known technique taught by Moore et al. to the subway car of Maekawa et al. in view of Amano et al. would have yielded predicable results and resulted in an improved system, namely, a

Art Unit: 3992

screen of the monitor being substantially flushed, substantially contiguous or flushed with the adjacent wall surface structure for a monitor being projecting slightly beyond the adjacent wall surface structure in Maekawa et al. in view of Amano et al. to provide a means to compensate for wall thickness or, the availability of space beyond the surface of the wall.

Similarly, the examiner asserts that simple substitution of one known element for another would obtain predictable results. That is, the substitution of one known element (a screen of the monitor being substantially flushed, substantially contiguous or flushed with the adjacent wall surface structure as shown in Moore et al.) for another (a monitor being projecting slightly beyond the adjacent wall surface structure as shown in Moore et al., Maekawa et al. and Amano et al.) would have been obvious to one of ordinary skill in the art at the time of the invention since the substitution of a screen of the monitor being substantially flushed, substantially contiguous or flushed with the adjacent wall surface structure in Maekawa et al. in view of Amano et al. would have yielded predictable results, namely, providing a screen of the monitor being substantially flushed, substantially contiguous or flushed with the adjacent wall surface structure in Maekawa et al. in view of Amano et al. to provide a means to compensate for wall thickness or, the availability of space beyond the surface of the wall.

Furthermore, the examiner asserts use of known technique to improve similar devices in the same way is obvious to one of ordinary skill in the art. That is, the manner of enhancing a particular device (providing a screen of the monitor being substantially flushed, substantially contiguous or flushed with the adjacent wall surface structure) was

Art Unit: 3992

made part of the ordinary capabilities of one skilled in the art based upon the teaching of such improvement in Moore et al. Accordingly, one of ordinary skill in the art would have been capable of applying this known "improvement" technique in the same manner to the prior art subway car of Maekawa et al. in view of Amano et al. and the results would have been predictable to one of ordinary skill in the art, namely, one skilled in the art would have readily recognized that providing a screen of the monitor being substantially flushed, substantially contiguous or flushed with the adjacent wall surface structure in Maekawa et al. in view of Amano et al. would positively provide a means to compensate for wall thickness or, the availability of space beyond the surface of the wall.

Issue 17

27. Claims 15-18 are rejected under 35 U.S.C. 103(a) as being unpatentable over Shinagawa et al. (Japanese. Publication No. JP 04-160991 A) in view of Amano et al. (Japanese. Publication No. JP 02-23985 A) and Moore et al. (U.S. Patent No. 3,480,727).

With respect to the limitation of claim 15, Shinagawa et al. discloses

A subway car for mass transportation

As shown in Figure 4, Shinagawa et al. discloses a car body of an electric train in which information is displayed during transit (car of a train; page 619, column 1).

Art Unit: 3992

including longitudinal opposed sidewalls that further comprise a segment and a ceiling adjoining the sidewalls with the segment disposed at the junction of the sidewall and the ceiling,

In addition, Shinagawa et al. discloses the train car including a pair of longitudinal opposed sidewalls (see Figure 4) with each sidewall having a top wall portion at the junction between sidewall and ceiling in Figure 4. Also, as is evidenced by the disclosure on page 621, the information signal display device (21-2n; page 621, column 1; see Figures 1, 4) is positioned on the sidewalls of the train car. Moreover, Shinagawa et al. discloses the sidewalls meeting the transitional segment of the ceiling with the transitional segment disposed at the junction of the sidewall and the ceiling (see Figure 4). Similarly, Shinagawa et al. discloses a top portion of the train car which is considered to be the ceiling which is right next to and connected to the sidewalls, accordingly (see Figure 4).

the subway car further comprising: a video display system comprising: a plurality of video display monitors each having a video screen; and a video signal source unit operatively connected to said video display monitors;

Shinagawa et al. clearly discloses a video display system, in Figure 1, including a plurality of video display monitors (21-2n; page 621, column 1; see Figures 1, 4) with each having a video screen (**display**) as well as a video signal source unit (see Figure 1) operatively connected to said video display monitors (21-2n; page 621, column 1; see Figures 1, 4).

wherein said video display monitors are spaced along the length of the car on opposing sides of the subway.

Art Unit: 3992

Furthermore, Shinagawa et al. discloses the monitors (21-2n; page 621, column 1; see Figures 1, 4) being positioned in the middle of the length of each sidewall opposite each other (see Figure 4) with the monitors (21-2n; page 621, column 1; see Figures 1, 4) specifically being disposed on the sidewall of the train car (page 621, column 1, paragraph 3; see Figures 1, 4).

With respect to the limitation of claim 17, Shinagawa et al. discloses

wherein the video signal source unit is configured to display a series of short messages in sequence on said plurality of video display monitors.
and

Shinagawa et al. explicitly discloses the video signal source unit (see Figure 1) providing information (guide information; page 619) to the monitors (21-2n; page 621, column 1; see Figures 1, 4).

Shinagawa et al. discloses all of the limitations of the claimed invention, as previously set forth, except for specifically calling for the transitional segment/wall portion being part of the sidewalls; each of the monitors being disposed/mounted within the transitional wall portion at the junction of the sidewall and ceiling such that the video screen of the respective video display monitor is substantially contiguous with the adjacent surface structure of the transitional wall portion and being directed obliquely downwardly toward the car seats; an external surface of the longitudinal opposed sidewall, the exterior surface of said transitional segment and an external surface of the ceiling comprising a blended contour; the screen of the monitor being substantially flushed or flushed with the adjacent wall surface structure instead of the monitor being projecting slightly beyond the adjacent wall surface structure; the series of short

Art Unit: 3992

messages comprising advertising content with the advertising content providing an additional source of revenue for the operator of the subway car; and the video display monitors being each enclosed within an enclosure.

However, the transitional segment being part of the sidewalls and each of the monitors being mounted within the transitional wall portion at the junction of the sidewall and ceiling and directed obliquely downwardly toward the car seats is known in the art. Amano et al., for example, teaches each of the monitors being mounted within the transitional wall portion at the junction of the sidewall and ceiling (see Figures 4-6) and directed obliquely downwardly toward the car seats (see Figures 4-6). Such an arrangement of the monitors (information signal display device **8a-8n**; see Figures 2, 4-6) being disposed within the top-curved region portion between the ceiling and sidewall (see Figures 4-6) would blend or combine the monitors into an integrated whole⁴⁶ with the sidewall and the top curved portion/transitional wall portion at the junction between sidewall in order to allow the portion of the monitor (**8**) lying in the top curved portion/transitional wall portion to be directed/inclined downward towards the seat of the train car at an angle not including 90, 180 or 270 degrees (i.e. obliquely; see Figure 2) so that each video screen (**display**) is readily visible to passengers in the train car. Similarly, such an arrangement of the monitors (information signal display device **8a-8n**) being disposed/mounted within the top-curved region portion between the ceiling and sidewall (see Figures 4-6) would make each monitor (**8**) be offset from of the surface of the sidewall facing the interior of the subway car to allow the monitor (**8**) which is facing

Art Unit: 3992

downward and lying in the top curved portion/transitional wall portion to be directed/inclined downward towards the seat of the train car at an angle not including 90, 180 or 270 degrees (i.e. obliquely; see Figure 2) so that each video screen (**display**) is readily visible to passengers in the train car. Furthermore, Amano et al. discloses the exposed opposed sidewalls to the interior of the train car, the top curved portion/transitional wall portion at the junction between sidewall and ceiling, and ceiling being combined into an integrated whole⁴⁷ (see Figures 4-6). Amano et al. further teaches such a configuration presents a means to provide the offering place for information in transportation equipment being used more effectively and sharpness being obtained, thereby increasing the information offering ability to passengers (English translation Abstract).

Similarly, a series of short messages comprising advertising content with the advertising content providing an additional source of revenue for the operator of the subway car is known in the art. Amano et al., for example, teaches the video signal source unit (display information signal transmitter 7) providing advertising content (nonroutine information; advertisements; cultural information, event information, theme park information, etc.; Abstract; pages 651, 653) to the monitors (information signal display device 8a-8n). Amano et al. further teaches such a configuration provides a means to reduce management time as well as strengthening the power of information provided due to "promptness" and "newness" (page 653).

⁴⁶ "blend." Merriam-Webster Online Dictionary. 2012. Merriam-Webster Online. 10 April 2012 <<http://www.merriam-webster.com/dictionary/blend>>

Art Unit: 3992

With respect to the limitation of “with the video screen of each video display monitor being **substantially contiguous** with an exterior surface of said transitional segment” of claim 15, the examiner can find no explicit disclosure to each video display monitor being “substantially contiguous” or “contiguous” with an exterior surface of the transitional segment within the instant specification. The term “contiguous” is defined as “being in actual contact : touching along a boundary or at a point” or “touching or connected throughout in an unbroken sequence”⁴⁸. The examiner looks to the instant Patent specification to ascertain which definition would be comparable to the Owner’s instant Patent disclosure.

As asserted above, the instant Patent specification discloses

An alternative embodiment is illustrated in FIG. 4A, a view similar to that of FIG. 4. In this alternative embodiment, CRT video monitor 22 is replaced with an LCD-based video monitor 22A which is of thin, rectangular cross-section, and occupies less space in the ceiling structure of the car. Accordingly, it can be moved towards the ceiling so that its viewing screen is substantially flush with or even behind the light panel 40. This use of an LCD-based monitor gives a better aesthetic appearance to the inside of the subway car as a whole, as well as improving the display performance by minimizing the interference effects, as previously discussed. (Page 5, lines 35-46).

Similarly, the instant Patent specification discloses

The screens are preferably covered with a rigid transparent unit, e.g. of polycarbonate, shaped to coincide with the shape of the internal wall of the subway car at the location of mounting. For example, when the monitor is mounted at the junction of the wall and ceiling of the subway car, where there is commonly provided a concavely curved segment of internal wall, the transparent cover unit is suitably similarly concavely curved, so that it can be mounted as a continuum with the internal walls and blended to contours

⁴⁷ "blend." Merriam-Webster Online Dictionary. 2012. Merriam-Webster Online. 10 April 2012
<<http://www.merriam-webster.com/dictionary/blend>>

⁴⁸ "contiguous." Merriam-Webster Online Dictionary. 2012. Merriam-Webster Online. 10 April 2012
<<http://www.merriam-webster.com/dictionary/contiguous>>

Art Unit: 3992

thereof, with the monitor mounted behind it. (Column 3, line 64 – column 4, line 8; see Figure 6) and;

*An alternative arrangement is shown in FIG. 6. Here **the polycarbonate shield 44 is convexly curved**, and is disposed further forward from the monitor screen 44. **The shield 44 now blends with forward facing part 48 the exterior skin and body structure 34**, to provide a perhaps more aesthetically appealing arrangement.* (Column 5, lines 57-62)

Again, as asserted above, the

“CRT video monitor is replaced with an LCD-based video monitor 22A which is of thin, rectangular cross-section, and occupies less space in the ceiling structure of the car”.

In Figure 4A above, Owner explicitly discloses the monitor 22A being behind the light panel 40 (see Figure 4A above). Owner alludes to the monitor 22A being “substantially flush”, however, never provides explicit disclosure of the embodiment. Moreover, after further examination of Figure 4A, the actual viewing screen of the monitor 22A can never really be flush with the light panel since the screen of the monitor 22A is further behind the transport screen 44A of the appropriately shaped enclosure 42A, hence there is an actual space and/or distance between the actual viewing screen of the monitor 22A and the transport screen 44A of the appropriately shaped enclosure 42A. Furthermore, Owner never defines the term “flushed” and only alludes to the disclosure of “substantially flushed” in light of Figure 4A. Figure 4A clearly does not show the embodiment of the screen being “substantially flushed” with the adjacent wall surface structure and, additionally provides evidence to the fact that the screen of the display monitor can never have or form a continuous plane or unbroken

Art Unit: 3992

surface⁴⁹ with the adjacent wall surface structure, but can only form a surface that is offset therefrom or "substantially flushed", in light of the Owner's instant disclosure.

As asserted above, The term "*contiguous*" is defined as "being in actual contact : touching along a boundary or at a point" or "touching or connected throughout in an unbroken sequence"⁵⁰. Since Owner discloses that the screen of the display monitor can never have or form a continuous plane or unbroken surface⁵¹ with the adjacent wall surface structure, but can only form a surface that is offset therefrom or "substantially flushed", the term "substantially contiguous" can only be "*not wholly* in actual contact : touching along a boundary or at a point" or offset therefrom not "touching or connected throughout in an unbroken sequence".

Therefore, the term "substantially contiguous" can only be deemed as "*not wholly* in actual contact : touching along a boundary or at a point" or a surface that is offset therefrom or "substantially flushed", since the Owner has further not explicitly defined the term "contiguous" or any embodiment of the instant Patent having a video screen of each video display monitor being **substantially contiguous** with an exterior surface of the transitional segment, only to an embodiment of a video screen of each video display monitor being **substantially flushed** or **a surface that is offset from** an exterior surface of the transitional segment (see explanation above). Furthermore, any other interpretation of the term "substantially contiguous" not being "*not wholly* in actual

⁴⁹ "flush." Merriam-Webster Online Dictionary. 2012. Merriam-Webster Online. 10 April 2012
<<http://www.merriam-webster.com/dictionary/flush>>

⁵⁰ "contiguous." Merriam-Webster Online Dictionary. 2012. Merriam-Webster Online. 10 April 2012
<<http://www.merriam-webster.com/dictionary/contiguous>>

⁵¹ "flush." Merriam-Webster Online Dictionary. 2012. Merriam-Webster Online. 10 April 2012
<<http://www.merriam-webster.com/dictionary/flush>>

Art Unit: 3992

contact : touching along a boundary or at a point" or "a surface that is offset therefrom" or "substantially flushed" would be deemed new matter since there is no explicit disclosure to any other embodiment.

In that light, screen of the monitor being substantially flushed or substantially contiguous with the adjacent wall surface structure/exterior surface of a transitional segment is known in the art. Moore et al., for example, teaches a screen of a monitor being substantially flushed with the adjacent wall surface structure as being an equivalent structure in the art (column 7, lines 41-44). Moreover, since the screen of the monitor is flushed with the adjacent wall surface structure, the video display monitor would additionally have to be "not wholly in actual contact with; or touching along a boundary or at a point"⁵² or "substantially contiguous with an exterior surface of the wall segment, as set forth above. Furthermore, since the screen of the monitor is flushed or forming a continuous plane or unbroken surface⁵³ with the adjacent wall, by shear definition the video display monitor/screen would have no protuberances. Moore et al. further teaches such a configuration provides a means to compensate for wall thickness or, the availability of space beyond the surface of the wall (column 7, lines 44-47).

Likewise, video display monitors being each enclosed within an enclosure is known in the art. Moore et al., for example, teaches a video monitor system (see Figures 1, 2) which may have a plurality of monitors (column 7, lines 59-63) with each

⁵² "contiguous." Merriam-Webster Online Dictionary. 2012. Merriam-Webster Online. 10 April 2012 <<http://www.merriam-webster.com/dictionary/contiguous>>

⁵³ "flush." Merriam-Webster Online Dictionary. 2012. Merriam-Webster Online. 10 April 2012 <<http://www.merriam-webster.com/dictionary/flush>>

⁵³

Art Unit: 3992

video display monitors being enclosed within an enclosure (frame members **162**, **163**, **165**, etc. combination; column 6, lines 58-66; see Figures 1, 2). Moore et al. further teaches such a configuration provides a means to facilitate removal of the monitor for repair and/or service any elements of the monitor (column 2, lines 33-38; column 7, lines 32-40), thereby increasing the ease of operational maintenance of the monitors.

It would have been obvious to one of ordinary skill in the art at the time of the invention was made to modify the train car wall/ceiling junction and the mounting and screen direction orientation of the monitors of Shinagawa et al. with each of the monitors being mounted within the transitional wall portion at the junction of the sidewall and ceiling and directed obliquely downwardly toward the car seats of Amano et al. in order to present a means to provide the offering place for information in transportation equipment being used more effectively and sharpness being obtained, thereby increasing the information offering ability to passengers. Similarly, it would have been obvious to one of ordinary skill in the art at the time of the invention was made to modify the short messages of Shinagawa et al. with the series of short messages comprising advertising content of Amano et al. in order to provide a means to reduce management time as well as strengthening the power of information provided due to "promptness" and "newness".

Likewise, it would have been obvious to one of ordinary skill in the art at the time of the invention was made to modify each of the video display monitors of Shinagawa et al. in view of Amano et al. with each of the video display monitors being enclosed within

Art Unit: 3992

an enclosure of Moore et al. in order to provide a means to facilitate removal of the monitor for repair and/or service any elements of the monitor, thereby increasing the ease of operational maintenance of the monitors.

Similarly, it would have been obvious to one of ordinary skill in the art at the time of the invention was made to modify the monitor being projecting slightly beyond the adjacent wall surface structure of the car of Shinagawa et al. in view of Amano et al. with the screen of the monitor being substantially flushed, substantially contiguous or flushed with the adjacent wall surface structure of Moore et al. in order to provide a means to compensate for wall thickness or, the availability of space beyond the surface of the wall. In addition, because these two monitor/wall configurations were art recognized equivalents at the time the invention was made, one of ordinary skill in the art would have found it obvious to substitute a screen of the monitor being substantially flushed or flushed with the adjacent wall surface structure for a monitor being projecting slightly beyond the adjacent wall surface structure.

In addition, the examiner asserts that applying a known technique to a known device ready for improvement would yield predictable results. That is, it would have been recognized by one of ordinary skill in the art that applying the known technique taught by Moore et al. to the subway car of Shinagawa et al. in view of Amano et al. would have yielded predictable results and resulted in an improved system, namely, a screen of the monitor being substantially flushed, substantially contiguous or flushed with the adjacent wall surface structure for a monitor being projecting slightly beyond the adjacent wall surface structure in Shinagawa et al. in view of Amano et al. to provide

Art Unit: 3992

a means to compensate for wall thickness or, the availability of space beyond the surface of the wall.

Likewise, the examiner asserts that simple substitution of one known element for another would obtain predictable results. That is, the substitution of one known element (a screen of the monitor being substantially flushed, substantially contiguous or flushed with the adjacent wall surface structure as shown in Moore et al.) for another (a monitor being projecting slightly beyond the adjacent wall surface structure as shown in Moore et al. and Amano et al.) would have been obvious to one of ordinary skill in the art at the time of the invention since the substitution of a screen of the monitor being substantially flushed, substantially contiguous or flushed with the adjacent wall surface structure in Shinagawa et al. in view of Amano et al. would have yielded predictable results, namely, providing a screen of the monitor being substantially flushed, substantially contiguous or flushed with the adjacent wall surface structure in Shinagawa et al. in view of Amano et al. to provide a means to compensate for wall thickness or, the availability of space beyond the surface of the wall.

Furthermore, the examiner asserts use of known technique to improve similar devices in the same way is obvious to one of ordinary skill in the art. That is, the manner of enhancing a particular device (providing a screen of the monitor being substantially flushed, substantially contiguous or flushed with the adjacent wall surface structure) was made part of the ordinary capabilities of one skilled in the art based upon the teaching of such improvement in Moore et al. Accordingly, one of ordinary skill in the art would have been capable of applying this known "improvement" technique in the same

Art Unit: 3992

manner to the prior art subway car of Shinagawa et al. in view of Amano et al. and the results would have been predictable to one of ordinary skill in the art, namely, one skilled in the art would have readily recognized that providing a screen of the monitor being substantially flushed, substantially contiguous or flushed with the adjacent wall surface structure in Shinagawa et al. in view of Amano et al. would positively provide a means to compensate for wall thickness or, the availability of space beyond the surface of the wall.

Issue 18: Claim Objections

28. Claims 19 and 20 are objected to as being dependent upon a rejected base claim, but would be allowable if rewritten in independent form including all of the limitations of the base claim and any intervening claims.

The following is a statement of reasons for the indication of allowable subject matter: Amano et al. discloses a panel disposed on the transitional segment disposed adjacent the ceiling a respective sidewall that displays advertising material to riders of the train car. However, indication of allowable subject matter of claims 19 and 20 are indicated because none of the prior art of record teaches or fairly suggests teaches a subway car, with all of the limitations of independent claim 19, particularly at least the limitations of "a backlit panel disposed on the transitional segment disposed adjacent the ceiling a respective sidewall" in combination with the apparatus limitations as set forth in the claims. The other claim, 20, is indicated as allowable subject at least because it depend from is indicated as an allowable subject dependent claim.

REMARKS

Owners Arguments

Issue 1: Rejections under 35 under 35 U.S.C. 102(b) by Minesaki

29. With respect to Owners reply/argument that Minesaki fails to expressly or inherently describe "each of said monitor being mounted at the junction of the sidewall and ceiling", the examiner respectfully disagrees. As Owner has noted, Minesaki discloses

This information transmission display part J may also be formed on the sidewall of the train car (page 590, right upper most column).

Minesaki further discloses such a configuration in the annotated Figure 2, as shown below

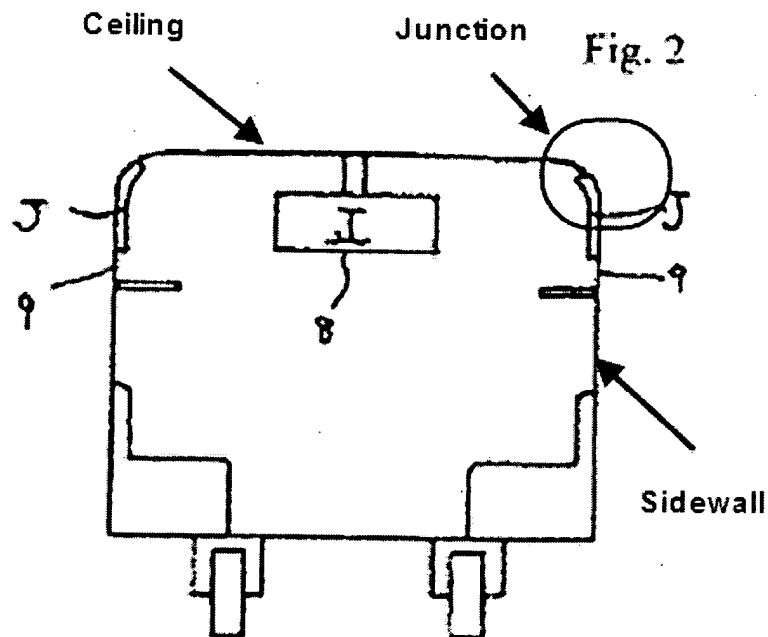

Art Unit: 3992

In the annotated Figure 2 above, Minesaki illustrates a ceiling portion, a sidewall portion, and a junction portion between the respective sidewall and ceiling portions (see above). In addition, the monitor (information transmission display part J) is clearly partially mounted and disposed in the junction portion between the respective sidewall and ceiling portions. Therefore, Minesaki fully meets “each of said monitor being mounted at the junction of the sidewall and ceiling” given its broadest reasonable interpretation.

30. With respect to Owners reply/argument that Minesaki fails to expressly or inherently describe “with the screen of the monitor substantially flushed with the adjacent wall surface structure of the car”, the examiner respectfully disagrees. Although the claims are interpreted in light of the specification, limitations from the specification are not read into the claims. See *In re Van Geuns*, 988 F.2d 1181, 26 USPQ2d 1057 (Fed. Cir. 1993).

In that regard, it is improper to import claim limitations from the specification. “Although claims of issued patents are interpreted in light of the specification, prosecution history, prior art and other claims, this is not the mode of claim interpretation to be applied during examination. During examination, the claims must be interpreted as broadly as their terms reasonably allow” (see MPEP § 2111). “Though understanding the claim language may be aided by explanations contained in the written description, it is important not to import into a claim limitations that are not part of the claim. For example, a particular embodiment appearing in the written description

Art Unit: 3992

may not be read into a claim when the claim language is broader than the embodiment” (again see MPEP § 2111).

As asserted in the previous Office action

(T)he term “substantially” is often used in conjunction with another term to describe a particular characteristic of the claimed invention. It is a broad term. (See MPEP 2173.05).

The recitation to “flush” is modified by the term “substantially” which essentially broadens the recitation of “flush”. The term “flush” is examined as “forming a continuous plane or unbroken surface.”⁵⁴ The limitation of “substantially flushed” recites the screen of the monitor not forming a continuous plane or unbroken surface, but to the screen *not wholly forming* a continuous plane or unbroken surface with the adjacent wall surface structure. Owner discloses

An alternative embodiment is illustrated in FIG. 4A, a view similar to that of FIG. 4. In this alternative embodiment, CRT video monitor 22 is replaced with an LCD-based video monitor 22A which is of thin, rectangular cross-section, and occupies less space in the ceiling structure of the car. Accordingly, it can be moved towards the ceiling so that its viewing screen is substantially flush with or even behind the light panel 40. This use of an LCD-based monitor gives a better aesthetic appearance to the inside of the subway car as a whole, as well as improving the display performance by minimizing the interference effects, as previously discussed. (Page 5, lines 35-46)

Included below is Figure 4A.

⁵⁴ “flush.” Merriam-Webster Online Dictionary. 2012. Merriam-Webster Online. 10 April 2012 <<http://www.merriam-webster.com/dictionary/flush>>

Art Unit: 3992

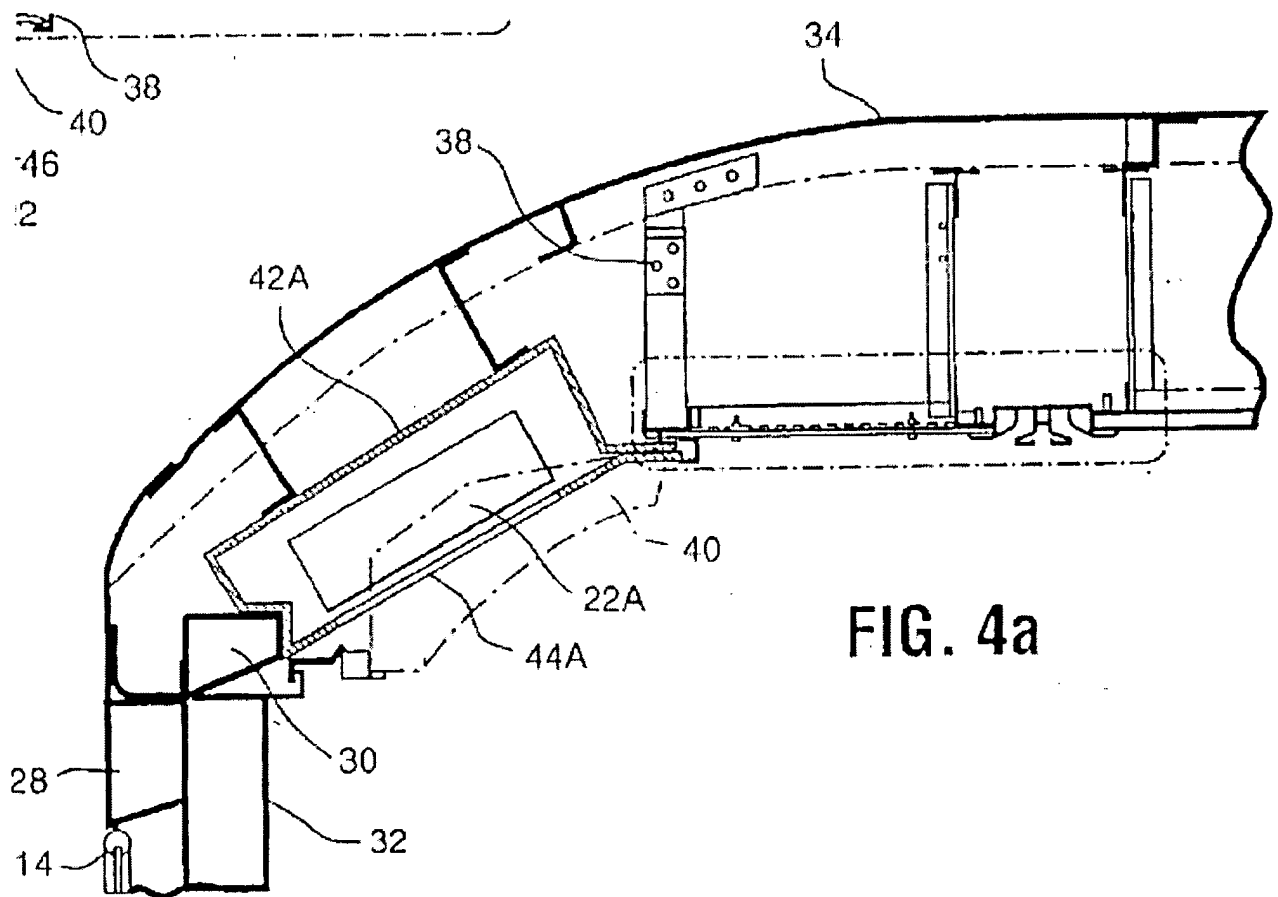

FIG. 4a

As asserted above, the

"CRT video monitor is replaced with an LCD-based video monitor 22A which is of thin, rectangular cross-section, and occupies less space in the ceiling structure of the car".

In Figure 4A, Owner explicitly discloses the monitor 22A being behind the light panel 40 (see Figure 4A above). Owner alludes to the monitor 22A being "substantially flush", however, never provides explicit disclosure of the embodiment. Moreover, after further examination of Figure 4A, the actual viewing screen of the monitor 22A can never really be flush with the light panel since the screen of the monitor 22A is further behind the transport screen 44A of the appropriately shaped enclosure 42A, hence there is an

Art Unit: 3992

actual space and/or distance between the actual viewing screen of the monitor **22A** and the transport screen **44A** of the appropriately shaped enclosure **42A**. Furthermore, Owner never defines the term “flushed” and only alludes to the disclosure of “substantially flushed” in light of Figure 4A. Figure 4A clearly does not show the embodiment of the screen being “substantially flushed” with the adjacent wall surface structure and, additionally provides evidence to the fact that screen of the display monitor can never form a continuous plane or unbroken surface with the adjacent wall surface structure, but can only form a surface that is offset therefrom or “substantially flushed”, in light of the Owner's instant disclosure.

In that light, Minesaki clearly discloses a “liquid crystal panel”, **J**, being formed on the sidewall **9** and such a “liquid crystal panel” would have a low profile, as shown above. A “liquid crystal panel” would never be really flush with the sidewall, however, the “liquid crystal panel”, **J**, would be “substantially flush”, or offset therefrom, in light of the instant Owner's disclosure. Therefore, Minesaki clearly discloses “the screen of the monitor (being) *substantially flushed* with the adjacent wall surface structure of the car” given its broadest reasonable interpretation.

31. With respect to Owners reply/argument that Minesaki fails to expressly or inherently describe “the screen of the monitor... (is) directed obliquely downward toward the car seats”, the examiner respectfully disagrees. The Owner further argues that the recitation to “the screen of the monitor... (is) directed obliquely downward toward the car seats” does not include prior art in which “only portions of the screen of the monitor are directed obliquely downwardly”. It is noted that the features upon which applicant relies

Art Unit: 3992

(i.e. the total screen of the monitor being directed obliquely downward toward the car seats) are not recited in the rejected claim(s). Although the claims are interpreted in light of the specification, limitations from the specification are not read into the claims. See *In re Van Geuns*, 988 F.2d 1181, 26 USPQ2d 1057 (Fed. Cir. 1993).

In that regard, it is improper to import claim limitations from the specification. “Although claims of issued patents are interpreted in light of the specification, prosecution history, prior art and other claims, this is not the mode of claim interpretation to be applied during examination. During examination, the claims must be interpreted as broadly as their terms reasonably allow” (see MPEP § 2111). “Though understanding the claim language may be aided by explanations contained in the written description, it is important not to import into a claim limitations that are not part of the claim. For example, a particular embodiment appearing in the written description may not be read into a claim when the claim language is broader than the embodiment” (again see MPEP § 2111).

It is asserted by the examiner that Owner has conceded that

“Patent Owner admits that the information transmission display parts J of Minesaki appear curved with the top portion seemingly directed obliquely downwardly...” (page 8, lines 18-19).

Minesaki clearly discloses portions of the screen of the monitor **J** being directed obliquely downward toward the car seats, as is evidenced by Figure 2. Therefore, since portions of the monitor screen of Minesaki are directed obliquely downward toward the car seats, Minesaki fully meets “the screen of the monitor... (is) directed obliquely downward toward the car seats” given its broadest reasonable interpretation.

Art Unit: 3992

Issue 2: Rejections under 35 U.S.C. 102(b) by Amano et al

32. With respect to Owners reply/argument that Amano et al. fails to expressly or inherently describe “with the screen of the monitor substantially flushed with the adjacent wall surface structure of the car”, the examiner respectfully disagrees.

Although the claims are interpreted in light of the specification, limitations from the specification are not read into the claims. See *In re Van Geuns*, 988 F.2d 1181, 26 USPQ2d 1057 (Fed. Cir. 1993).

In that regard, it is improper to import claim limitations from the specification. “Although claims of issued patents are interpreted in light of the specification, prosecution history, prior art and other claims, this is not the mode of claim interpretation to be applied during examination. During examination, the claims must be interpreted as broadly as their terms reasonably allow” (see MPEP § 2111). “Though understanding the claim language may be aided by explanations contained in the written description, it is important not to import into a claim limitations that are not part of the claim. For example, a particular embodiment appearing in the written description may not be read into a claim when the claim language is broader than the embodiment” (again see MPEP § 2111).

As asserted in the previous Office action

(T)he term “substantially” is often used in conjunction with another term to describe a particular characteristic of the claimed invention. It is a broad term. (See MPEP 2173.05).

Art Unit: 3992

The recitation to “flush” is modified by the term “substantially” which essentially broadens the recitation of “flush”. The term “flush” is examined as “forming a continuous plane or unbroken surface.”⁵⁵ The limitation of “substantially flushed” recites the screen of the monitor not forming a continuous plane or unbroken surface, but to the screen *not wholly forming* a continuous plane or unbroken surface with the adjacent wall surface structure. Owner discloses

An alternative embodiment is illustrated in FIG. 4A, a view similar to that of FIG. 4. In this alternative embodiment, CRT video monitor 22 is replaced with an LCD-based video monitor 22A which is of thin, rectangular cross-section, and occupies less space in the ceiling structure of the car. Accordingly, it can be moved towards the ceiling so that its viewing screen is substantially flush with or even behind the light panel 40. This use of an LCD-based monitor gives a better aesthetic appearance to the inside of the subway car as a whole, as well as improving the display performance by minimizing the interference effects, as previously discussed. (Page 5, lines 35-46)

Included below is Figure 4A.

⁵⁵ “flush.” Merriam-Webster Online Dictionary. 2012. Merriam-Webster Online. 10 April 2012 <<http://www.merriam-webster.com/dictionary/flush>>

Art Unit: 3992

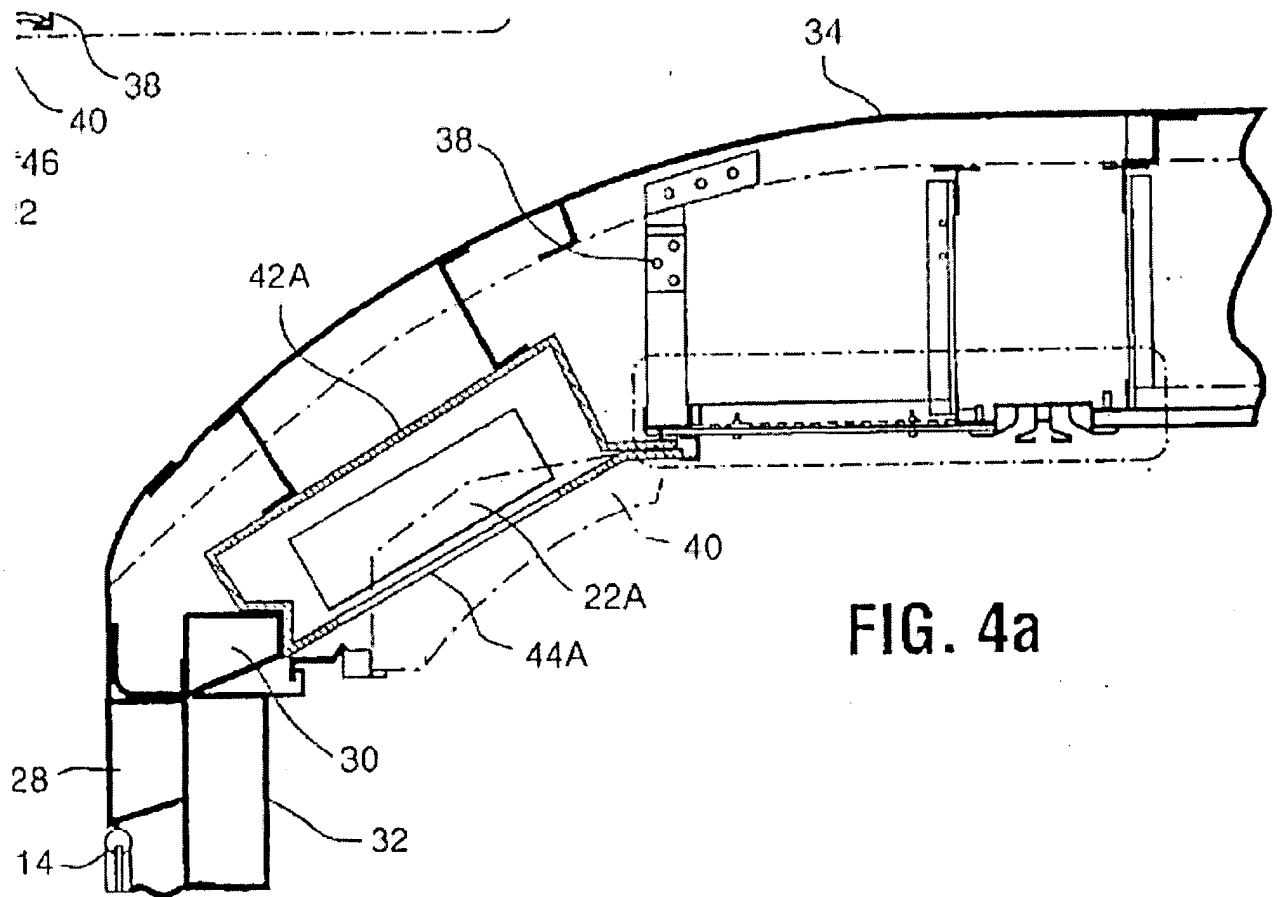

FIG. 4a

As asserted above, the

"CRT video monitor is replaced with an LCD-based video monitor 22A which is of thin, rectangular cross-section, and occupies less space in the ceiling structure of the car".

In Figure 4A, Owner explicitly discloses the monitor 22A being behind the light panel 40 (see Figure 4A above). Owner alludes to the monitor 22A being "substantially flush", however, never provides explicit disclosure of the embodiment. Moreover, after further examination of Figure 4A, the actual viewing screen of the monitor 22A can never really be flush with the light panel since the screen of the monitor 22A is further behind the transport screen 44A of the appropriately shaped enclosure 42A, hence there is an

Art Unit: 3992

actual space and/or distance between the actual viewing screen of the monitor **22A** and the transport screen **44A** of the appropriately shaped enclosure **42A**. Furthermore, Owner never defines the term “flushed” and only alludes to the disclosure of “substantially flushed” in light of Figure 4A. Figure 4A clearly does not show the embodiment of the screen being “substantially flushed” with the adjacent wall surface structure and, additionally provides evidence to the fact that screen of the display monitor can never form a continuous plane or unbroken surface with the adjacent wall surface structure, but can only form a surface that is offset therefrom or “substantially flushed”, in light of the Owner’s instant disclosure.

In that light, Amano et al. clearly discloses “information signal devices **8a-8n**” being formed on the transitional portion of the sidewalls, as shown in Figures 4, 5 and 6. The “information signal devices **8a-8n**” would never be really flush with the sidewall, however, the “information signal devices **8a-8n**” would be “substantially flush”, or offset therefrom, in light of the instant Owner’s disclosure. Therefore, Amano et al. clearly discloses “the screen of the monitor (being) substantially flushed with the adjacent wall surface structure of the car” given its broadest reasonable interpretation.

Issue 3: Rejections under 35 U.S.C. 103(a) as being unpatentable over

Maekawa et al. in view of Amano et al

33. With respect to Owners reply/argument that Maekawa et al. fails to teach or suggest “the screen of the monitor (is) substantially flushed with the adjacent wall surface structure of the car”, the examiner respectfully disagrees. Although the claims

Art Unit: 3992

are interpreted in light of the specification, limitations from the specification are not read into the claims. See *In re Van Geuns*, 988 F.2d 1181, 26 USPQ2d 1057 (Fed. Cir. 1993).

In that regard, it is improper to import claim limitations from the specification. "Although claims of issued patents are interpreted in light of the specification, prosecution history, prior art and other claims, this is not the mode of claim interpretation to be applied during examination. During examination, the claims must be interpreted as broadly as their terms reasonably allow" (see MPEP § 2111). "Though understanding the claim language may be aided by explanations contained in the written description, it is important not to import into a claim limitations that are not part of the claim. For example, a particular embodiment appearing in the written description may not be read into a claim when the claim language is broader than the embodiment" (again see MPEP § 2111).

As asserted in the previous Office action

(T)he term "substantially" is often used in conjunction with another term to describe a particular characteristic of the claimed invention. It is a broad term. (See MPEP 2173.05).

The recitation to "flush" is modified by the term "substantially" which essentially broadens the recitation of "flush". The term "flush" is examined as "forming a continuous plane or unbroken surface."⁵⁶ The limitation of "substantially flushed" recites the screen of the monitor not forming a continuous plane or unbroken surface, but to the screen not

⁵⁶ "flush." Merriam-Webster Online Dictionary. 2012. Merriam-Webster Online. 10 April 2012 <<http://www.merriam-webster.com/dictionary/flush>>

Art Unit: 3992

wholly forming a continuous plane or unbroken surface with the adjacent wall surface structure. Owner discloses

An alternative embodiment is illustrated in FIG. 4A, a view similar to that of FIG. 4. In this alternative embodiment, CRT video monitor 22 is replaced with an LCD-based video monitor 22A which is of thin, rectangular cross-section, and occupies less space in the ceiling structure of the car. Accordingly, it can be moved towards the ceiling so that its viewing screen is substantially flush with or even behind the light panel 40. This use of an LCD-based monitor gives a better aesthetic appearance to the inside of the subway car as a whole, as well as improving the display performance by minimizing the interference effects, as previously discussed. (Page 5, lines 35-46)

Included below is Figure 4A.

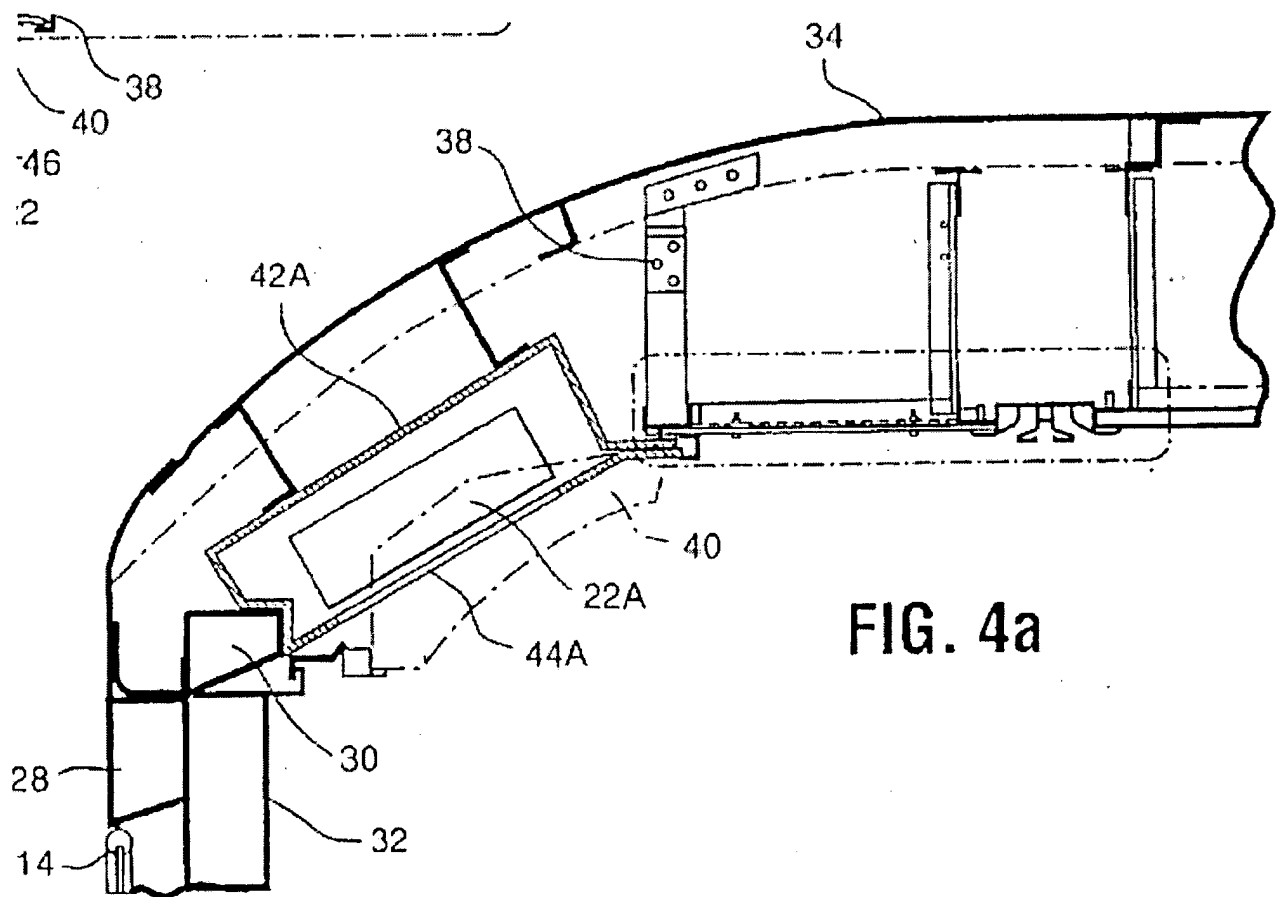

FIG. 4a

As asserted above, the

Art Unit: 3992

"CRT video monitor is replaced with an LCD-based video monitor 22A which is of thin, rectangular cross-section, and occupies less space in the ceiling structure of the car".

In Figure 4A, Owner explicitly discloses the monitor **22A** being behind the light panel **40** (see Figure 4A above). Owner alludes to the monitor **22A** being "substantially flush", however, never provides explicit disclosure of the embodiment. Moreover, after further examination of Figure 4A, the actual viewing screen of the monitor **22A** can never really be flush with the light panel since the screen of the monitor **22A** is further behind the transport screen **44A** of the appropriately shaped enclosure **42A**, hence there is an actual space and/or distance between the actual viewing screen of the monitor **22A** and the transport screen **44A** of the appropriately shaped enclosure **42A**. Furthermore, Owner never defines the term "flushed" and only alludes to the disclosure of "substantially flushed" in light of Figure 4A. Figure 4A clearly does not show the embodiment of the screen being "substantially flushed" with the adjacent wall surface structure and, additionally provides evidence to the fact that screen of the display monitor can never form a continuous plane or unbroken surface with the adjacent wall surface structure, but can only form a surface that is offset therefrom or "substantially flushed", in light of the Owner's instant disclosure.

In that light, Maekawa et al. clearly discloses the screen (**display**) of the plurality of monitor (**101-124**) being placed on the sidewall so that each video screen (**display**) is readily visible to passengers in the subway car, as is evidenced by Figure 2. In addition, Maekawa et al. discloses the plurality of monitor (**101-124**) being a "liquid crystal panel" having a low profile (page 738, bottom right portion). A "liquid crystal panel" would never

Art Unit: 3992

be really flush with the sidewall, however, the “liquid crystal panel”, would be “substantially flush”, or offset therefrom, in light of the instant Owner’s disclosure. Therefore, Maekawa et al. clearly discloses “the screen of the monitor (being) substantially flushed with the adjacent wall surface structure of the car” given its broadest reasonable interpretation.

Issue 4: Rejections under 35 U.S.C. 103(a) as being unpatentable over Shinagawa et al. in view of Amano et al.

With respect to Owners reply/argument that Shinagawa et al. fails to teach or suggest “the screen of the monitor (is) substantially flushed with the adjacent wall surface structure of the car”, the examiner respectfully agrees. Shinagawa explicitly discloses

The display devices 21 to 2n are arranged on the walls flanking the aisles of each train or above the windows of the passenger seats at approximately the eye level of an average adult walking by. (Page 621, bottom left portion)

Shinagawa et al. clearly discloses no particular type of monitor being utilized or even a pictured profile example of the display devices on the wall (see Figure 4). Therefore, the examiner deems that Shinagawa et al., alone, does not teach or suggest “the screen of the monitor (is) substantially flushed with the adjacent wall surface structure of the car”, given its broadest reasonable interpretation. Therefore, the rejection of claim 1 over Shinagawa et al. in view of Amano et al. has been withdrawn

Art Unit: 3992

Issue 5: Rejections under 35 U.S.C. 103(a) as being unpatentable over Minesaki in view of Moore et al.

34. With respect to Owners reply/argument that Minesaki fails to expressly or inherently describe "each of said monitor being mounted at the junction of the sidewall and ceiling", the examiner respectfully disagrees. As Owner has noted, Minesaki discloses

This information transmission display part J may also be formed on the sidewall of the train car (page 590, right upper most column).

Minesaki further discloses such a configuration in the annotated Figure 2, as shown below

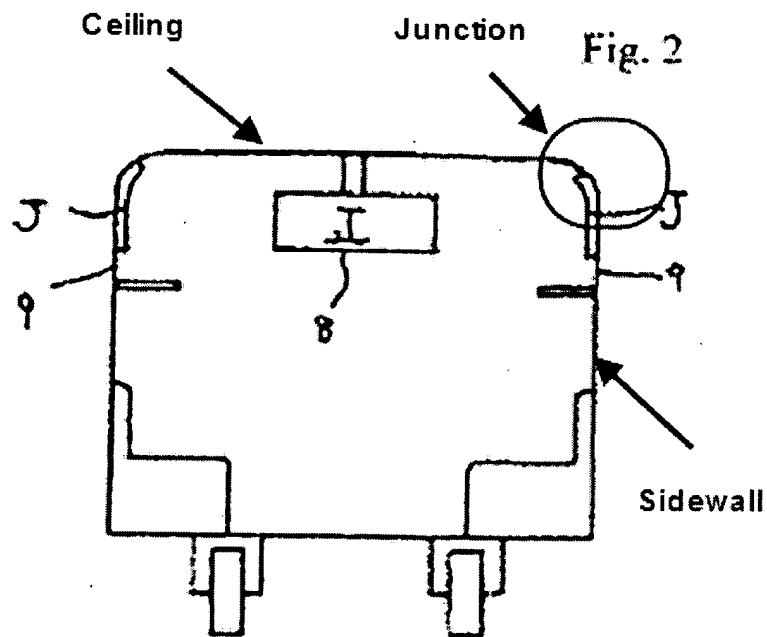

In the annotated Figure 2 above, Minesaki illustrates a ceiling portion, a sidewall portion, and a junction portion between the respective sidewall and ceiling portions (see

Art Unit: 3992

above). In addition, the monitor (information transmission display part J) is clearly partially mounted and disposed in the junction portion between the respective sidewall and ceiling portions. Therefore, Minesaki fully meets each of said monitor being mounted at the junction of the sidewall and ceiling "each of said monitor being mounted at the junction of the sidewall and ceiling" given its broadest reasonable interpretation.

35. With respect to Owners reply/argument that Minesaki fails to expressly or inherently describe "the screen of the monitor... (is) directed obliquely downward toward the car seats", the examiner respectfully disagrees. The Owner further argues that the recitation to "the screen of the monitor...(is) directed obliquely downward toward the car seats" does not include prior art in which "only portions of the screen of the monitor are directed obliquely downwardly". It is noted that the features upon which applicant relies (i.e. the total screen of the monitor being directed obliquely downward toward the car seats) are not recited in the rejected claim(s). Although the claims are interpreted in light of the specification, limitations from the specification are not read into the claims. See *In re Van Geuns*, 988 F.2d 1181, 26 USPQ2d 1057 (Fed. Cir. 1993).

In that regard, it is improper to import claim limitations from the specification. "Although claims of issued patents are interpreted in light of the specification, prosecution history, prior art and other claims, this is not the mode of claim interpretation to be applied during examination. During examination, the claims must be interpreted as broadly as their terms reasonably allow" (see MPEP § 2111). "Though understanding the claim language may be aided by explanations contained in the written description, it is important not to import into a claim limitations that are not part of

Art Unit: 3992

the claim. For example, a particular embodiment appearing in the written description may not be read into a claim when the claim language is broader than the embodiment” (again see MPEP § 2111).

It is asserted by the examiner that Owner has conceded that

“Patent Owner admits that the information transmission display parts J of Minesaki appear curved with the top portion seemingly directed obliquely downwardly...” (page 8, lines 18-19).

Minesaki clearly discloses portion of the screen of the monitor J being directed obliquely downward toward the car seats, as is evidenced by Figure 2. Therefore, since portions of the monitor screen of Minesaki are directed obliquely downward toward the car seats, Minesaki fully meets “the screen of the monitor...(is) directed obliquely downward toward the car seats” given its broadest reasonable interpretation.

Issue 6: Rejections under 35 U.S.C. 103(a) as being unpatentable over Amano et al. in view of Moore et al.

36. With respect to Owner’s reply/argument that Amano et al. teaches away from “the screen monitor (being) substantially flushed with the adjacent wall surface structure of the car”, the examiner respectfully disagrees. While Amano et al. teaches a preferred embodiment of the screen of the monitor protruding a certain distance from the transitional portion of the sidewall (see Figures 4-6), disclosed examples and preferred embodiments do not constitute a teaching away from a broader disclosure or non-preferred embodiments. Furthermore, the examiner can find no teaching to criticize, discredit or otherwise discourage trying to make the screen of monitor substantially

Art Unit: 3992

flush with the adjacent wall surface structure of the car (see MPEP § 2123). Therefore, the examiner asserts that Amano et al. does not teach away from using a screen monitor that is substantially flushed with the adjacent wall surface structure of Moore et al. given its broadest reasonable interpretation.

37. Furthermore, in response to Owner's reply/ argument that the modifications to the area near the junction of the sidewall and ceiling of the Amano et al. train would render the Amano et al. train unsatisfactory for its intended purpose because the storage area would have to be eliminated entirely or substantially reduced, the test for obviousness is not whether the features of a secondary reference may be bodily incorporated into the structure of the primary reference; nor is it that the claimed invention must be expressly suggested in any one or all of the references. Rather, the test is what the combined teachings of the references would have suggested to those of ordinary skill in the art. See *In re Keller*, 642 F.2d 413, 208 USPQ 871 (CCPA 1981).

In that light, the storage devices of Amano et al. are permanent structures of the train, as is evidenced by Figures 4-6. Specifically, the storage area structures in Figures 5 and 6 are independent of the information signal display devices 8. Similarly, the storage device in Figure 4 seems to have a slotted area in which one of ordinary skill in the art would render the information signal display devices 8 as also being independent from the storage device. Clearly, the modification of the information signal display devices 8 of Amano et al. to be "substantially flushed", as taught by Moore et al., would not destroy the functionality of the storage devices of Amano et al, but instead, provide even more potential area for storage. Therefore, the examiner asserts that the

Art Unit: 3992

replacement of the slightly protruding information signal display devices 8 of Amano et al. with the "substantially flushed" monitors of Moore et al. would not render Amano et al. unsatisfactory for its intended purpose because Amano et al. would still provide real-time information to the users of the train via the monitors as well as potentially even more adequate storage for particular items.

Issue 7: Rejections under 35 U.S.C. 103(a) as being unpatentable over Maekawa et al. in view of Amano et al. and Moore et al.

38. Furthermore, in response to Owner's reply/ argument that the modifications to the area near the junction of the sidewall and ceiling of the Amano et al. train would render the Amano et al. train unsatisfactory for its intended purpose because the storage area would have to be eliminated entirely or substantially reduced, the test for obviousness is not whether the features of a secondary reference may be bodily incorporated into the structure of the primary reference; nor is it that the claimed invention must be expressly suggested in any one or all of the references. Rather, the test is what the combined teachings of the references would have suggested to those of ordinary skill in the art. See *In re Keller*, 642 F.2d 413, 208 USPQ 871 (CCPA 1981).

In that light, the storage devices of Amano et al. are permanent structures of the train, as is evidenced by Figures 4-6. Specifically, the storage area structures in Figures 5 and 6 are independent of the information signal display devices 8. Similarly, the storage device in Figure 4 seems to have a slotted area in which one of ordinary skill in the art would render the information signal display devices 8 as also being independent

Art Unit: 3992

from the storage device. Clearly, the modification of the information signal display devices 8 of Amano et al. to be "substantially flushed", as taught by Moore et al., would not destroy the functionality of the storage devices of Amano et al, but instead, provide even more potential area for storage. Therefore, the examiner asserts that the replacement of the slightly protruding information signal display devices 8 of Amano et al. with the "substantially flushed" monitors of Moore et al. would not render Amano et al. unsatisfactory for its intended purpose because Amano et al. would still provide real-time information to the users of the train via the monitors as well as potentially even more adequate storage for particular items.

Conclusion

THIS ACTION IS MADE FINAL.

A shortened statutory period for response to this action is set to expire *TWO (2) MONTHS* from the mailing date of this action.

Extensions of time under 37 CFR 1.136(a) do not apply in reexamination proceedings. The provisions of 37 CFR 1.136 apply only to "an applicant" and not to parties in a reexamination proceeding. Further, in 35 U.S.C. 305 and in 37 CFR 1.550(a), it is required that reexamination proceedings "will be conducted with special dispatch within the Office."

Extensions of time in reexamination proceedings are provided for in 37 CFR 1.550(c). A request for extension of time must be filed on or before the day on which a response to this action is due, and it must be accompanied by the petition fee set forth in 37 CFR 1.17(g). The mere filing of a request will not effect any extension of time. An extension of time will be granted only for sufficient cause, and for a reasonable time specified.

The filing of a timely first response to this final rejection will be construed as including a request to extend the shortened statutory period for an additional month, which will be granted even if previous extensions have been granted. In no event however, will the statutory period for response expire later than **SIX MONTHS** from the mailing date of the final action. See MPEP § 2265.

The patent owner is reminded of the continuing responsibility under 37 CFR 1.565(a), to apprise the Office of any litigation activity, or other prior or concurrent

Art Unit: 3992

proceeding, involving Patent No. 6,700,602 throughout the course of this reexamination proceeding. See MPEP §§ 2207, 2282 and 2286.

All correspondence relating to this ex parte reexamination proceeding should be directed:

By Mail to: Mail Stop *Ex Parte* Reexam
Central Reexamination Unit
Commissioner for Patents
United States Patent & Trademark Office
P.O. Box 1450
Alexandria, VA 22313-1450

By FAX to: (571) 273-9900
Central Reexamination Unit

By hand: Customer Service Window
Randolph Building
401 Dulany Street
Alexandria, VA 22314

By EFS-Web:

Registered users of EFS-Web may alternatively submit such correspondence via the electronic filing system EFS-Web, at

<https://efs.uspto.gov/efile/myportal/efs-registered>

EFS-Web offers the benefit of quick submission to the particular area of the Office that needs to act on the correspondence. Also, EFS-Web submissions are "soft scanned" (i.e., electronically uploaded) directly into the official file for the reexamination proceeding, which offers parties the opportunity to review the content of their submissions after the "soft scanning" process is complete.

Art Unit: 3992

Any inquiry concerning this communication or earlier communications from the Reexamination Legal Advisor or Examiner, or as to the status of this proceeding, should be directed to the Central Reexamination Unit at telephone number (571) 272-7705.

/Stephen J Ralis/
Primary Examiner, Art Unit 3992

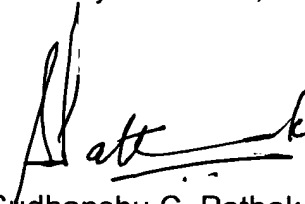

Sudhanshu C. Pathak
Supervisory Patent Examiner
Art Unit 3992



Luke S. Wassum
Patent Examiner, Art Unit 3992

Reexamination 	Application/Control No. 90011861	Applicant(s)/Patent Under Reexamination 6700602
	Certificate Date	Certificate Number

Requester Correspondence Address: **Patent Owner** **Third Party**

GAZDZINSKI & ASSOCIATES, PC
16644 WEST BERNARDO DRIVE
SUITE 201
SAN DIEGO, CA 92127

LITIGATION REVIEW <input checked="" type="checkbox"/>	SR (examiner initials)	09/27/2011 (date)
Case Name		Director Initials
No Litigation is currently pending.		<i>Al for IY.</i>

COPENDING OFFICE PROCEEDINGS	
TYPE OF PROCEEDING	NUMBER
1. No copending proceedings.-	

--	--

Search Notes 	Application/Control No. 90011861	Applicant(s)/Patent Under Reexamination 6700602
	Examiner STEPHEN RALIS	Art Unit 3992

SEARCHED			
Class	Subclass	Date	Examiner

SEARCH NOTES		
Search Notes	Date	Examiner
Reviewed proposed prior art and patent prosecution history.	9/23/2011	SR
Text Searching Strategies (see EAST notes)	9/26/2011	SR
Reviewed proposed prior art and patent prosecution history.	12/23/2011	SR
Reviewed proposed prior art and patent prosecution history.	4/9/2012	SR

INTERFERENCE SEARCH			
Class	Subclass	Date	Examiner

--	--



UNITED STATES PATENT AND TRADEMARK OFFICE

UNITED STATES DEPARTMENT OF COMMERCE
United States Patent and Trademark Office
Address: COMMISSIONER FOR PATENTS
P.O. Box 1450
Alexandria, Virginia 22313-1450
www.uspto.gov

APPLICATION NO.	FILING DATE	FIRST NAMED INVENTOR	ATTORNEY DOCKET NO.	CONFIRMATION NO.
90/011,861	08/16/2011	6700602	BLAIR.001A	3736

27299 7590 06/12/2012
GAZDZINSKI & ASSOCIATES, PC
16644 WEST BERNARDO DRIVE
SUITE 201
SAN DIEGO, CA 92127

EXAMINER

ART UNIT PAPER NUMBER

DATE MAILED: 06/12/2012

Please find below and/or attached an Office communication concerning this application or proceeding.

Ex Parte Reexamination Interview Summary	Control No. 90/011,861	Patent Under Reexamination 6700602
	Examiner STEPHEN RALIS	Art Unit 3992

All participants (USPTO personnel, patent owner, patent owner's representative):

- | | |
|-----------------------------|----------------------------|
| (1) <u>STEPHEN RALIS</u> | (3) <u>Luke Wassum</u> |
| (2) <u>Sudhanshu Pathak</u> | (4) <u>Peter Gutierrez</u> |

Date of Interview: 11 June 2012

Type: a) Telephonic b) Video Conference
c) Personal (copy given to: 1) patent owner 2) patent owner's representative)

Exhibit shown or demonstration conducted: d) Yes e) No.
If Yes, brief description: _____

Agreement with respect to the claims f) was reached. g) was not reached. h) N/A.
Any other agreement(s) are set forth below under "Description of the general nature of what was agreed to..."

Claim(s) discussed: 8, 9, 15, 19, 21 and 22.

Identification of prior art discussed: _____.

Description of the general nature of what was agreed to if an agreement was reached, or any other comments:
See Continuation Sheet.

(A fuller description, if necessary, and a copy of the amendments which the examiner agreed would render the claims patentable, if available, must be attached. Also, where no copy of the amendments that would render the claims patentable is available, a summary thereof must be attached.)

A FORMAL WRITTEN RESPONSE TO THE LAST OFFICE ACTION MUST INCLUDE PATENT OWNER'S STATEMENT OF THE SUBSTANCE OF THE INTERVIEW. (See MPEP § 2281). IF A RESPONSE TO THE LAST OFFICE ACTION HAS ALREADY BEEN FILED, THEN PATENT OWNER IS GIVEN **ONE MONTH FROM THIS INTERVIEW DATE TO PROVIDE THE MANDATORY STATEMENT OF THE SUBSTANCE OF THE INTERVIEW (37 CFR 1.560(b)). THE REQUIREMENT FOR PATENT OWNER'S STATEMENT CAN NOT BE WAIVED. **EXTENSIONS OF TIME ARE GOVERNED BY 37 CFR 1.550(c).****

/Stephen J Ralis/
Primary Examiner, Art Unit 3992

cc: Requester (if third party requester)

Continuation of Description of the general nature of what was agreed to if an agreement was reached, or any other comments: Owner and the Office discussed the current pending Office action status of the instant reexamination proceedings. Owner provided the examiner with an agenda for discussion purposes. Discussion focused on independent claims 8 and 21 and the potential amendments to overcome the 35 U.S.C. 112, first paragraph, and 35 U.S.C. 305 respective rejections. The examiner asserted that the proposed amendments would overcome the 35 U.S.C. 112, first paragraph, and 35 U.S.C. 305 respective rejections. The examiner also asserted that dependent claims 9 and 22 (i.e. dependent from independent claims 8 and 21, respectively) provide further issues with respect of the "transparent cover unit" and the "rigid transparent unit". Owner noted the issues and intends to resolve the potential issues, accordingly. Owner provided further amendments to independent claim 15 and dependent claim 19 to overcome the outstanding claim objections, as set forth in the Office action mailed 25 April 2012. The examiner asserted that the potential amendment does not resolve the outstanding claim objections, since the claimed subject matter deemed objected to (i.e. a backlit panel disposed on the transitional segment disposed adjacent the ceiling a respective sidewall) is not recited in independent claim 15. Owner queried the examiner to whether claim 19, as current recited, can be placed into independent claim 15 without including the limitations of preceding dependent claims 17 and 18. The examiner agreed that claim 19, as currently objected to, may be placed into independent claim 15 without the limitations of preceding dependent claims 17 and 18. The Office and Owner also agreed that the Owner has a time period to end on 25 June 2012 to reply to the Office action, mailed 25 April 2012. The Office further asserted that if the Patent Owner fails to file a timely and appropriate response to any Office action or any written statement of an interview required under § 1.560(b), the prosecution in the ex parte reexamination proceeding will be a terminated prosecution, and the Director will proceed to issue and publish a certificate concluding the reexamination proceeding under § 1.570 in accordance with the last action of the Office.

BLAIR.001A

PATENT

IN THE UNITED STATES PATENT AND TRADEMARK OFFICE

Patentee	:	Scott Blair)	Fax No. (571) 273.6227
Patent No.	:	6,700,602 – Issued 03/02/04)	Attn: Stephen Ralis
Control No.	:	90/011,861)	
Filed	:	August 16, 2011)	
For	:	SUBWAY TV MEDIA SYSTEM)	
Examiner	:	Stephen Ralis)	
Group Art Unit:	:	3992)	

5

Topics for Discussion

- I. Amendments to Claims 8, 9, 15, and 19 – 23 in order to resolve:
 - a. Rejection of Claims 8 – 14 and 21 – 30 in view of 35 U.S.C. § 112, first paragraph
 - b. Rejection of Claims 8 – 14 in view of 35 U.S.C. § 305; and
 - c. Claim objection of Claims 19 and 20

10

Respectfully submitted,

15

GAZDZINSKI & ASSOCIATES, PC

Dated: June 6, 2012

20

By: 
 Peter J. Gutierrez, III
 Registration No. 56,732
 16644 West Bernardo Drive, Suite 201
 San Diego, CA 92127
 Telephone No.: (858) 675-1670
 Facsimile No.: (858) 675-1674

25

Control No. : 90/011,861
Filed : August 16, 2011

3. The subway car of claim 1 wherein the program is repeatable, and includes a series of commercial messages of 30 second-1 minute duration.

4. The video system subway car of claim 1 which is sound free.

5 5. The subway car of claim 1 wherein the video signal source unit comprises a video tape player, a video disk player or computer-based digital video recorder.

6. The subway car of claim 1 wherein the video monitors include LCD screens.

7. The subway car of any of claim 1 including a self-contained wiring-cabling system connecting the video monitors to the video signal source unit.

8. (Amended) A subway car for mass transportation, comprising:

10 a video display system comprising a plurality of video display monitors each having a video screen, and a video signal source unit operatively connected to said video display monitors;

a plurality of transparent cover units that cover respective ones of the video display monitors;

15 a pair of longitudinal opposed sidewalls, each of the sidewalls comprising a transitional wall portion at the junction of the sidewall and ceiling that is directed obliquely downwardly; and

a ceiling adjoining the sidewalls;

20 wherein the monitors are spaced along the length of the car on opposed sides thereof, the monitors being disposed within the transitional wall portion such that the transparent cover units covering respective ones of the video display monitors ~~video screen of the respective video display monitor~~ are substantially flush ~~blends~~ with the adjacent surface structure of the transitional wall portion, wherein the monitors are ~~and is~~ also directed obliquely downwardly toward the car seats so that each video screen is readily visible to passengers in the subway car.

25 9. (Amended) The subway car of Claim 8, wherein the ~~video screen of the video display monitor~~ plurality of transparent cover units each comprises a rigid transparent unit configured to protect the video display monitor.

10. The subway car of Claim 9, wherein the video display monitor is disposed within the transitional wall portion such that it contains no visible edges or protuberances.

Control No. : 90/011,861
Filed : August 16, 2011

11. The subway car of Claim 8, further comprising a back lit panel disposed on the transitional wall portion, the back lit panel disposed adjacent the video screen of the video display monitor.

12. The subway car of Claim 8, wherein the video display monitors are each enclosed within an enclosure.

13. The subway car of Claim 12, wherein the enclosure is secured to a structural member disposed between an inner wall and an outer structural shell of the subway car.

14. The subway car of Claim 13, wherein the enclosure and a respective video display monitor is removable from the subway car as a unit.

15. (Amended) A subway car for mass transportation including longitudinal opposed sidewalls that further comprise a transitional segment and a ceiling adjoining the sidewalls with the transitional segment disposed at the junction of the sidewall and the ceiling, the subway car further comprising:

a video display system comprising:

a plurality of video display monitors each having a video screen; and

a video signal source unit operatively connected to said video display monitors;

wherein said video display monitors are spaced along the length of the car on opposing sides of the subway, each of the video display monitors being mounted within the transitional segment, with the video screen of each video display monitor being substantially contiguous with an exterior surface of said transitional segment, said video screen being directed obliquely downwardly toward the car seats so that each video screen is readily visible to passengers in the subway car; and

an advertising panel disposed on the transitional segment disposed adjacent the ceiling and a respective sidewall.

16. The subway car of Claim 15, wherein an external surface of the longitudinal opposed sidewall, the exterior surface of said transitional segment and an external surface of the ceiling comprise a blended contour.

17. The subway car of Claim 15, wherein the video signal source unit is configured to display a series of short messages in sequence on said plurality of video display monitors.

Control No. : 90/011,861
Filed : August 16, 2011

18. The subway car of Claim 17, wherein the series of short messages comprise advertising content, said advertising content providing an additional source of revenue for the operator of the subway car.

19. (Amended) The subway car of Claim 18, wherein the advertising panel
5 further comprises comprising a back lit panel disposed on the transitional segment disposed adjacent the ceiling and ~~[[a]] the~~ respective sidewall.

20. (Amended) The subway car of Claim 19, wherein the back lit panel is disposed adjacent the video screen of the video display monitor.

21. (Amended) A subway car for mass transportation including longitudinal
10 opposed sidewalls, a ceiling adjoining the sidewalls, a video display system comprising a plurality of video display monitors each having a video screen, and a video signal source unit operatively connected to said monitors,

said monitors being spaced along the length of the car on opposed sides thereof, each of said monitors being mounted at the junction of the sidewall and ceiling and further being
15 covered with a transparent cover unit, with the transparent cover unit ~~screen of the monitor~~ flushed with the adjacent wall surface structure of the car, and with the monitors directed obliquely downwardly toward the car seats, so that each video screen is readily visible to passengers in the subway car.

22. (Amended) The subway car of Claim 21, wherein the ~~display portion of the~~
20 ~~video display monitor~~ transparent cover unit for a respective video display monitor comprises a rigid transparent unit configured to protect the video display monitor.

23. (Amended) The subway car of Claim 21, wherein the ~~video display monitor~~
transparent cover unit is flushed within the adjacent wall structure such that it contains no protuberances.

24. The subway car of Claim 21, further comprising a back lit panel disposed on the
25 adjacent wall surface structure of the car.

25. The subway car of Claim 21, wherein the video display monitors are each enclosed within an enclosure.

26. The subway car of Claim 25, wherein the enclosure is secured to a structural
30 member disposed between an inner wall and an outer structural shell of the subway car.

Control No. : 90/011,861
Filed : August 16, 2011

27. The subway car of Claim 26, wherein the enclosure and a respective video display monitor is removable from the subway car as a unit.

28. The subway car of Claim 21, wherein an external surface of the longitudinal opposed sidewalls, the adjacent wall surface structure and an external surface of the ceiling
5 comprise a blended contour.

29. The subway car of Claim 21, wherein the video signal source unit is configured to display a series of short messages in sequence on said plurality of video display monitors.

30. The subway car of Claim 29, wherein the series of short messages comprise advertising content, said advertising content providing an additional source of revenue for the
10 operator of the subway car.

IN THE UNITED STATES PATENT AND TRADEMARK OFFICE

Patentee : Scott Blair)
 Patent No. : 6,700,602 – Issued 03/02/04)
 Control No. : 90/011,861)
 Filed : August 16, 2011)
 For : **SUBWAY TV MEDIA SYSTEM**)
 Examiner : Stephen Ralis)
 Group Art Unit: 3992)



27299

PATENT TRADEMARK OFFICE

CERTIFICATE OF ELECTRONIC (EFS-WEB) TRANSMISSION

I hereby certify that this correspondence is being transmitted via the Office electronic filing system in accordance with 37 C.F.R. § 1.8(a)(1)(C) from the Pacific Time Zone of the United States on the local date shown below.

Dated: June 25, 2012

By: [Signature] Peter J. Gutierrez, III, Reg. No. 56,732

5

RESPONSE TO FINAL OFFICE ACTION – EX PARTE REEXAMINATION

10 Mail Stop *Ex Parte* Reexam
 Central Reexamination Unit
 Commissioner for Patents
 United States Patent & Trademark Office
 P.O. Box 1450
 15 Alexandria, VA 22313-1450

Dear Sir:

In response to the Final Office Action in *Ex Parte* Reexamination dated April 25, 2012 (“*Ex Parte* Office Action”), the following is provided:

20

Control No. : 90/011,861
Filed : August 16, 2011

IN THE CLAIMS

United States Patent No. 6,700,602 (hereinafter “the ’602 Patent”) issued with Claims 1 – 7. By this paper, Claims 1 – 7 are set forth herein in their original state. New Claims 8 – 30 were previously added. By this paper, Patent Owner has amended Claims 8, 9, 15 and 20 – 23 and cancelled Claim 19 without prejudice. Accordingly, Claims 1 – 18 and 20 – 30 are presented as follows:

1. A subway car for mass transportation including longitudinal opposed sidewalls, a ceiling adjoining the sidewalls, a video display system comprising a plurality of video display monitors each having a video screen, and a video signal source unit operatively connected to said monitors,

said monitors being spaced along the length of the car on opposed sides thereof, each of said monitor being mounted at the junction of the sidewall and ceiling, with the screen of the monitor substantially flushed with the adjacent wall surface structure of the car, and directed obliquely downwardly toward the car seats, so that each video screen is readily visible to passengers in the subway car.

2. The subway car of claim 1 wherein the video signal source system includes a pre-recorded video transmission program for feeding to display on the monitors of duration about 5-15 minutes.

3. The subway car of claim 1 wherein the program is repeatable, and includes a series of commercial messages of 30 second-1 minute duration.

4. The video system subway car of claim 1 which is sound free.

5. The subway car of claim 1 wherein the video signal source unit comprises a video tape player, a video disk player or computer-based digital video recorder.

6. The subway car of claim 1 wherein the video monitors include LCD screens.

7. The subway car of any of claim 1 including a self-contained wiring-cabling system connecting the video monitors to the video signal source unit.

8. (Amended) A subway car for mass transportation, comprising:

Control No. : 90/011,861
Filed : August 16, 2011

a video display system comprising a plurality of video display monitors each having a video screen, and a video signal source unit operatively connected to said video display monitors;

5 a plurality of transparent cover units that cover respective ones of the video display monitors;

a pair of longitudinal opposed sidewalls, each of the sidewalls comprising a transitional wall portion at the junction of the sidewall and ceiling that is directed obliquely downwardly;
and

a ceiling adjoining the sidewalls;

10 wherein the monitors are spaced along the length of the car on opposed sides thereof, the monitors being disposed within the transitional wall portion such that the transparent cover units covering respective ones of the video display monitors are substantially flush with the adjacent surface structure of the transitional wall portion, wherein the monitors are also directed obliquely downwardly toward the car seats so that each video screen is readily visible to
15 passengers in the subway car.

9. (Amended) The subway car of Claim 8, wherein the plurality of transparent cover units are rigid and are further configured to protect the video display monitor.

10. The subway car of Claim 9, wherein the video display monitor is disposed within the transitional wall portion such that it contains no visible edges or protuberances.

20 11. The subway car of Claim 8, further comprising a back lit panel disposed on the transitional wall portion, the back lit panel disposed adjacent the video screen of the video display monitor.

12. The subway car of Claim 8, wherein the video display monitors are each enclosed within an enclosure.

25 13. The subway car of Claim 12, wherein the enclosure is secured to a structural member disposed between an inner wall and an outer structural shell of the subway car.

14. The subway car of Claim 13, wherein the enclosure and a respective video display monitor is removable from the subway car as a unit.

30 15. (Amended) A subway car for mass transportation including longitudinal opposed sidewalls that further comprise a transitional segment and a ceiling adjoining the

Control No. : 90/011,861
Filed : August 16, 2011

sidewalls with the transitional segment disposed at the junction of the sidewall and the ceiling,
the subway car further comprising:

a video display system comprising:

a plurality of video display monitors each having a video screen; and

5 a video signal source unit operatively connected to said video display monitors;

wherein said video display monitors are spaced along the length of the car on opposing
sides of the subway, each of the video display monitors being mounted within the transitional
segment, with the video screen of each video display monitor being substantially contiguous
with an exterior surface of said transitional segment, said video screen being directed obliquely
10 downwardly toward the car seats so that each video screen is readily visible to passengers in the
subway car; and

a back lit panel disposed on the transitional segment disposed adjacent the ceiling and a
respective sidewall.

15 16. The subway car of Claim 15, wherein an external surface of the longitudinal
opposed sidewall, the exterior surface of said transitional segment and an external surface of the
ceiling comprise a blended contour.

17. The subway car of Claim 15, wherein the video signal source unit is configured
to display a series of short messages in sequence on said plurality of video display monitors.

20 18. The subway car of Claim 17, wherein the series of short messages comprise
advertising content, said advertising content providing an additional source of revenue for the
operator of the subway car.

19. (Cancelled)

20. (Amended) The subway car of Claim 15, wherein the back lit panel is
disposed adjacent the video screen of the video display monitor.

25 21. (Amended) A subway car for mass transportation including longitudinal
opposed sidewalls, a ceiling adjoining the sidewalls, a video display system comprising a
plurality of video display monitors each having a video screen, and a video signal source unit
operatively connected to said monitors,

30 said monitors being spaced along the length of the car on opposed sides thereof, each of
said monitors being mounted at the junction of the sidewall and ceiling and further being

Control No. : 90/011,861
Filed : August 16, 2011

covered with a transparent cover unit, with the transparent cover unit flushed with the adjacent wall surface structure of the car, and with the monitors directed obliquely downwardly toward the car seats, so that each video screen is readily visible to passengers in the subway car.

5 22. (Amended) The subway car of Claim 21, wherein the transparent cover unit for a respective video display monitor is rigid and is further configured to protect the video display monitor.

23. (Amended) The subway car of Claim 21, wherein the transparent cover unit is flushed within the adjacent wall structure such that it contains no protuberances.

10 24. The subway car of Claim 21, further comprising a back lit panel disposed on the adjacent wall surface structure of the car.

25. The subway car of Claim 21, wherein the video display monitors are each enclosed within an enclosure.

26. The subway car of Claim 25, wherein the enclosure is secured to a structural member disposed between an inner wall and an outer structural shell of the subway car.

15 27. The subway car of Claim 26, wherein the enclosure and a respective video display monitor is removable from the subway car as a unit.

28. The subway car of Claim 21, wherein an external surface of the longitudinal opposed sidewalls, the adjacent wall surface structure and an external surface of the ceiling comprise a blended contour.

20 29. The subway car of Claim 21, wherein the video signal source unit is configured to display a series of short messages in sequence on said plurality of video display monitors.

30. The subway car of Claim 29, wherein the series of short messages comprise advertising content, said advertising content providing an additional source of revenue for the operator of the subway car.

25

Control No. : 90/011,861
Filed : August 16, 2011

REMARKS

The '602 Patent issued with Claims 1 – 7. New Claims 8 – 30 were previously added. By this paper, Patent Owner has amended Claims 8, 9, 15 and 20 – 23 and cancelled Claim 19
5 without prejudice. Accordingly, Claims 1 – 18 and 20 – 30 are presented for examination herein.

Confirmed Claims

Per page 25 of the *Ex Parte* Office Action, it is believed that Claims 8 – 14 and 21 – 30 are
10 confirmable pending resolution of the Office's rejections under 35 U.S.C. §112, first paragraph and 35 U.S.C. §305.

Furthermore, per page 25 of the *Ex Parte* Office Action, dependent Claims 19 and 20 each stand objected to for depending from a rejected base claim, but would be confirmable if incorporated into independent Claim 15. By this paper, Patent Owner has amended Claim 15 to
15 incorporate the subject matter of objected-to Claim 19. Patent Owner notes that the proposed amendment to Claim 15 was the subject matter of the Interview referenced *infra*, and that the Office believed that Claim 15 as amended herein was confirmable.

Interview Summary

On June 11, 2012, the undersigned attorney of record (Peter J. Gutierrez, III) conducted an
20 interview with the Examiner Stephen Ralis as well as with Examiner Luke Wassum and Examiner's Ralis' Supervisory Examiner Sudhanshu Pathak. The topics of discussion for this scheduled interview were proposed Amendments to Claims 8, 9, 15, 19, 21 and 22 in order to resolve Issues 9, 10 and 18 as set forth in page 25 of the *Ex Parte* Office Action. As a result of this
25 interview, an agreement was reached with respect to resolving Issues 9, 10, and 18, and the Patent Owner respectfully submits that the proposed amendments to Claims 8, 9, 15 and 20 – 23 contained herein reflect the agreement reached during the interview. Patent Owner also believes that the above statements are consistent with the Interview Summary dated June 12, 2012.

30

Control No. : 90/011,861
Filed : August 16, 2011

35 U.S.C. §112, first paragraph

Per page 25 of the *Ex Parte* Office Action, Claims 8 – 14 and 21 – 30 each stand rejected in view of 35 U.S.C. §112, first paragraph, as allegedly failing to comply with the written description requirement. In response thereto, Applicant provides the following remarks:

5

Claim 8 – With respect to Claim 8, the Office takes issue with Patent Owner’s proposed language which states in part: *“the monitors being disposed within the transitional wall portion such that the video screen of the respective video display monitor substantially blends with the adjacent surface structure of the transitional wall portion”*. Specifically, the Office alleges that it is actually the shield of the enclosure that blends with the internal walls of the subway car and not the actual video screens of the monitors themselves. Without admission thereof, or addressing the merit or propriety of the Office’s rejection of Claim 8, by this paper, Patent Owner has amended Claim 8 such that it now recites: *“the monitors being disposed within the transitional wall portion such that the transparent cover units covering respective ones of the video display monitors are substantially flush with the adjacent surface structure of the transitional wall portion”*. Support for Patent Owner’s amendment can be found at Col. 3, line 64 – Col. 4, line 8 and Figure 6 of the ‘602 Patent as well as at Col. 5, lines 35 – 46 and Figure 4A of the ‘602 Patent. Accordingly, no new matter has been entered by virtue of Patent Owner’s amendment to Claim 8.

20 Furthermore, Patent Owner further notes that the proposed amendment to Claim 8 was the subject matter of the Interview referenced above, and that the Office believed that Claim 8 as amended herein resolved the Office’s 35 U.S.C. §112, first paragraph concerns and was confirmable.

25 **Claim 21** – With respect to Claim 21, the Office takes issue with Patent Owner’s proposed language which states in part: *“with the screen of the monitor flushed with the adjacent wall surface structure of the car”*. Specifically, the Office alleges that it is actually the shield of the enclosure that is flush with the adjacent wall surface structure of the car and not the actual video screens of the monitors themselves. Without admission thereof, or addressing the merit or propriety of the Office’s rejection of Claim 21, by this paper, Patent Owner has amended Claim 21 such that

30

Control No. : **90/011,861**
Filed : **August 16, 2011**

it now recites: “*the transparent cover unit flushed with the adjacent wall surface structure of the car*”. Support for Patent Owner’s amendment can be found at, *inter alia*, Col. 3, line 64 – Col. 4, line 8 and Figure 6 of the ‘602 Patent as well as at Col. 5, lines 35 – 46 and Figure 4A of the ‘602 Patent. Accordingly, no new matter has been entered by virtue of Patent Owner’s amendment to Claim 21.

Furthermore, Patent Owner further notes that the proposed amendment to Claim 21 was the subject matter of the Interview referenced above, and that the Office believed that Claim 21 as amended herein resolved the Office’s 35 U.S.C. §112, first paragraph concerns and was confirmable.

35 U.S.C. §305

Per page 32 of the *Ex Parte* Office Action, Claims 8 – 14 each stand rejected under 35 U.S.C. § 305 as enlarging the scope of the claim(s) of the patent being reexamined. Specifically, the Office alleges that the introduction of the term “blended” enlarges the scope of the claims. Without admission thereof, or addressing the merit or propriety of the Office’s rejection of Claim 8, Patent Owner has amended Claim 8 so that the term “blended” has been replaced with the term “flushed” consistent with Patent Owner’s terminology used in issued Claim 1. Accordingly, no new matter has been entered by virtue of Patent Owner’s amendment to Claim 8.

Furthermore, Patent Owner further notes that the proposed amendment to Claim 8 was the subject matter of the Interview referenced above, and that the Office believed that Claim 8 as amended herein resolved the Office’s 35 U.S.C. §305 concerns and was confirmable.

35 U.S.C. §102

1. Per page 4 of the Office Action, Claim 1 stands rejected under 35 U.S.C. §102 as being anticipated by Minesaki (Japanese Publication No. JP 63-125984, hereinafter “Minesaki”). In response thereto, Patent Owner provides the following remarks:

Claim 1 – Patent Owner respectfully submits that it is well established that “[a] claim is anticipated only if each and every element as set forth in the claim is found, either expressly or

Control No. : 90/011,861
Filed : August 16, 2011

inherently described, in a single prior art reference." Verdegaal Bros. v. Union Oil Co. of California, 814 F.2d 628, 631, 2 USPQ2d 1051, 1053 (Fed. Cir. 1987). See also MPEP §2131.

With regards to the Office's rejection of Claim 1 as being anticipated by Minesaki, Patent Owner respectfully traverses. Specifically, Minesaki fails to expressly or inherently describe: (1)
5 "each of said monitor being mounted at the junction of the sidewall and ceiling"; (2) "with the screen of the monitor substantially flushed with the adjacent wall surface structure of the car"; and (3) "directed obliquely downwardly toward the car seats".

With regards to the claimed feature "each of said monitor being mounted at the junction of the sidewall and ceiling", Minesaki appears to only contemplate two configurations for mounting
10 the information transmission display (part J). Specifically, one such configuration contemplated by Minesaki is an "information display part J ... which is suspended and hangs down from the ceiling". {emphasis added} Such a configuration as described does not expressly or inherently describe mounting the monitor at the junction of the sidewall and ceiling.

Minesaki's second configuration contemplates that the "information transmission display
15 part J may also be formed on the sidewall 9 of the train car." {emphasis added} Accordingly, Minesaki only appears to contemplate suspending the information transmission display part from the ceiling, or alternatively, forming the information transmission display part on the sidewall of the train car, and respectfully does *not* contemplate mounting the monitor at the junction of the sidewall and ceiling.

20 The Office alleges at page 100 of the *Ex Parte* Office Action that Fig. 2 of Minesaki illustrates the information transmission display part J at the junction of the sidewall and the ceiling. However, as set forth previously, Minesaki only describes that this information transmission display part is formed on the sidewall. Furthermore, Patent Owner respectfully submits that it is clear that the drawing of Fig. 2 is not intended to be to scale, and that the drafting quality of Fig. 2
25 is poor. For example, and as illustrated in Fig. 2, the information transmission display parts J are shown as being curved along the top portion of the display. However, Minesaki provides no mention or explanation for this curvature in its specification, and it would appear that such a curved feature is quite unusual in that it seemingly affects only the very top portion of the display shown in FIG. 2, which optically would seem to distort the light rays emanating from the display in
30 an inconsistent manner (and hence distort at least a portion of any image displayed thereon, akin to

a prism). Accordingly, it is believed that this drawing (Fig. 2) is at best unreliable (and at worst, inconsistent) in its teachings when considered without the context of the two configurations discussed *supra* provided by the written detailed description, and would not expressly or inherently describe a monitor being “mounted at the junction of the sidewall and ceiling” to one of ordinary skill in the art.

Furthermore, with regards to the claimed feature “with the screen of the monitor substantially flushed with the adjacent wall surface structure of the car”, the Office alleges that the term “substantially” is often used in conjunction with another term to describe a particular characteristic of the claimed invention, and is further construed to be a broad term (citing MPEP §2173.05). While Patent Owner agrees that the term “substantially” is construed broadly, the use of the term “substantially” cannot be construed so broadly as to read the term “flushed” completely out of the claim. See e.g., *Exxon Chem. Patents v. Lubrizol Corp.*, 64 F.3d 1553, 1555 (Fed. Cir. 1995), *cert. denied*, 518 U.S. 1020 (1996), as it believes the Office’s interpretation has done.

Furthermore, Patent Owner notes that terms in its claims must be interpreted in light of Patent Owner’s specification as filed; see MPEP § 2111; “During patent examination, the pending claims must be “given their broadest reasonable interpretation consistent with the specification.” *Phillips v. AWH Corp.*, 415 F.3d 1303, 75 USPQ2d 1321 (Fed. Cir. 2005)” {emphasis added}). Fig. 2 of Minesaki is reproduced below for the convenience of the Office.

Fig. 2

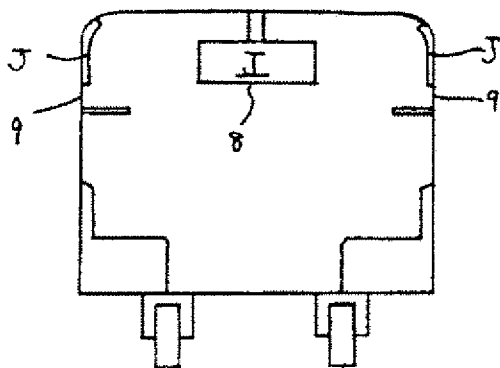
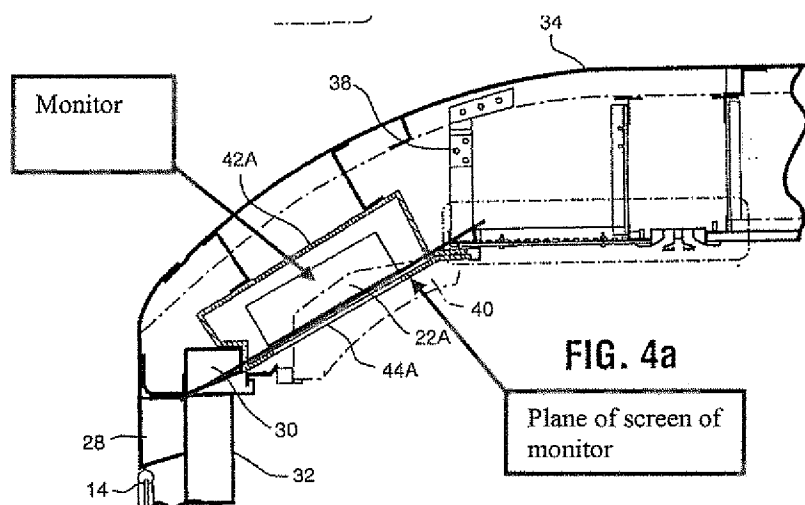

Figure 2 of Minesaki

As can be seen, there is not a single part of the information transmission display (part J) illustrated in Fig. 2 which can reasonably be considered to be flush with the adjacent wall surface (as Patent Owner has used that term in its specification and Claim 1); in fact, the entire information transmission display part J of Minesaki clearly protrudes away from the adjacent wall surface.

5 Patent Owner refers the Office to FIG. 4a of its specification (reproduced below for convenience), which clearly shows an embodiment of Patent Owner's invention that has a *screen* that is substantially flushed with the adjacent wall surface (as explicitly recited in Claim 1), and with no protrusion of the display (as occurs in Minesaki). As indicated in Patent Owner's specification regarding FIG. 4a, this configuration gives a better aesthetic appearance to the inside of the subway car as a whole, as well as improving the display performance by minimizing the interference effects.

10



F. 2, 2004

Sheet 4 of 6

US 6,700,602 B1

15

Accordingly, Patent Owner respectfully submits that the Office's interpretation of the term "*substantially flushed*" is improper, as the Office's interpretation completely reads out the "*flushed*" feature. In response to Patent Owner's previous assertions, the Office states that the term flush is "*examined as forming a continuous plane or unbroken surface.*" Furthermore, the Office

20 alleges that the screen of the display monitor illustrated in FIG. 4a above can never form a continuous plane or unbroken surface with the adjacent wall surface structure. However, the Office

Control No. : 90/011,861
Filed : August 16, 2011

alleges that this is the case because the screen is further behind the transport screen of the enclosure (see page 103 of the *Ex Parte* Office Action). Patent Owner submits that although the screen of the monitor is behind the transport screen, the use of the transport screen would give the appearance of a flush mounted monitor (“*substantially flush*”), even though the screen of the monitor would
5 actually be slightly offset from the adjacent wall surface structure of the car. Again, contrast with Minesaki, which illustrates information transmission display parts which would clearly not give the appearance of a flush mounted monitor.

Finally, Patent Owner respectfully submits that Minesaki does not expressly or inherently describe that “*the screen of the monitor ... [is] directed obliquely downwardly toward the car
10 seats*”. While Patent Owner admits that the information transmission display parts J of Minesaki appear curved with the top portion seemingly directed obliquely downwardly, the majority portion of the information transmission display part J is directed perpendicular to the sidewall of the Minesaki train (see Fig. 2 reproduced above). Furthermore, Patent Owner has set forth and claimed in Claim 1 that “*the screen of the monitor ... [is] directed obliquely downwardly toward the car
15 seats*” as opposed to setting forth and claiming that only portions of the screen of the monitor are directed obliquely downwardly. In response, the Office states that since portions of the monitor screen of Minesaki are directed obliquely downward toward the car seats, Minesaki fully meets Patent Owner’s claimed language. However, Patent Owner has actually claimed “*the screen of the
20 monitor ... directed obliquely downwardly toward the car seats, so that each video screen is readily visible to passengers in the subway car.*” Furthermore, the stated reasoning in Patent Owner’s specification states that the screen is: “*suitably angled downwardly, for best viewing by passengers seated opposite the screen*” (Col. 4, lines 6 – 7 of the ‘602 Patent); “*angled downwardly for ease of viewing of passengers 24 seated in such inward facing seats 16*” (Col. 5, lines 1 – 2 of the ‘602 Patent); and “*angled downwardly for best viewing by a passenger 24
25 seated opposite*” (Col. 5, lines 30 – 32 of the ‘602 Patent). Patent Owner respectfully submits that the arrangement illustrated in Minesaki would frustrate the ability for each video screen to be readily visible to passengers if only a portion of the screen were directed obliquely downwardly (due to *inter alia*, optical distortion associated with only the very top portion of light emanating from the screen), and that the Office’s interpretation of Patent Owner’s
30 language is inconsistent with Patent Owner’s specification.

Control No. : 90/011,861
Filed : August 16, 2011

Accordingly, Patent Owner submits that Claim 1 distinguishes on this independent and distinct basis as well.

2. Per page 6 of the Office Action, Claim 1 stands rejected under 35 U.S.C. §102 as
5 being anticipated by Amano et al. (Japanese Publication No. JP 02-23985 A, hereinafter
“Amano”). In response thereto, Patent Owner provides the following remarks:

Claim 1 – With regards to the Office’s rejection of Claim 1 as being anticipated by Amano,
Patent Owner respectfully traverses. Specifically, Patent Owner respectfully submits that Amano
10 fails to expressly or inherently describe “*the screen of the monitor substantially flushed with the
adjacent wall surface structure of the car*”.

Again, the Office alleges that the term “*substantially*” is often used in conjunction with
another term to describe a particular characteristic of the claimed invention and is further construed
to be a broad term (citing MPEP §2173.05). Again, Patent Owner respectfully submits that the use
15 of the term “*substantially*” cannot be construed so broadly as to read the term “*flushed*”
completely out of the claim. Figures 4 – 6 of Amano are reproduced below for the convenience of
the Office.

Figure 4

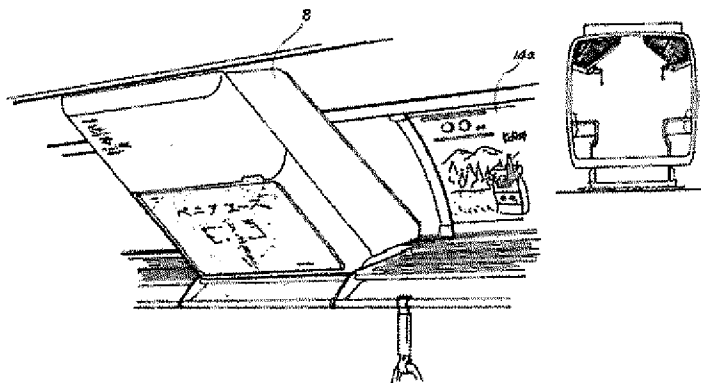

Figure 4 of Amano

Figure 5

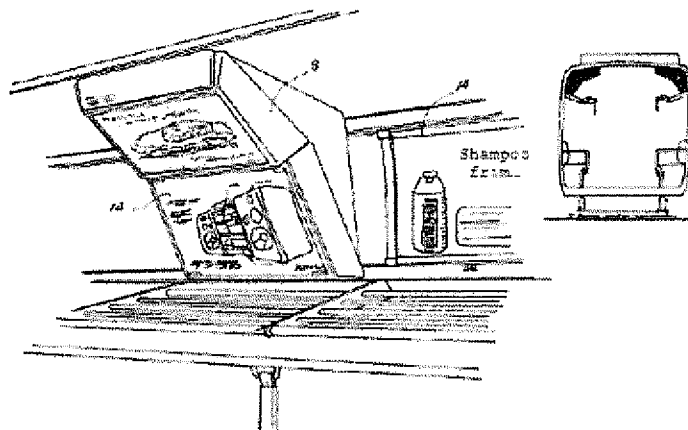

Figure 5 of Amano

Figure 6

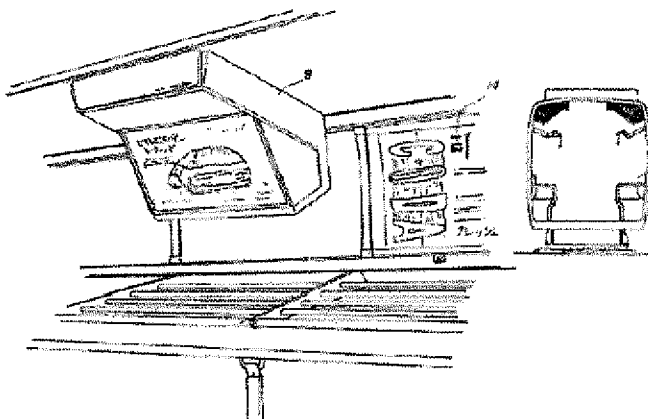

Figure 6 of Amano

5

As can be seen, there is not a single part of the information display device 8 illustrated in Figures 4 – 6 that can reasonably be considered to be *“flush with the adjacent wall surface”* as recited in Claim 1. In fact, the entire information display device 8 of Amano (including the screen, which is the component Patent Owner’s Claim 1 recites as being substantially flushed with the wall surface) clearly protrudes away from the adjacent wall surface. Patent Owner respectfully submits that the Office’s interpretation of the term *“substantially flushed”* is improper, as the Office’s interpretation completely reads out the *“flushed”* feature. See again FIG. 4a of the ‘602 Patent discussed *supra*.
10

In response to Patent Owner’s previous assertions, the Office states that the term flush is *“examined as forming a continuous plane or unbroken surface.”* Furthermore, the Office alleges

Control No. : 90/011,861
Filed : August 16, 2011

that the screen of the display monitor illustrated in FIG. 4a above can never form a continuous plane or unbroken surface with the adjacent wall surface structure. However, the Office alleges that this is the case because the screen is further behind the transport screen of the enclosure (see page 108 of the *Ex Parte* Office Action). Patent Owner submits that although the screen of the monitor is behind the transport screen, the use of the transport screen would give the appearance of a flush mounted monitor (“*substantially flush*”), even though the screen of the monitor would actually be slightly offset from the adjacent wall surface structure of the car. Again, contrast with Amano which illustrates information display devices which would clearly not give the appearance of a flush mounted monitor.

10 Accordingly, Patent Owner respectfully submits that the Office’s rejection of Claim 1 as being anticipated by Amano is improper, and should be withdrawn.

3. Per page 34 of the Office Action, Claims 15 – 18 each stand rejected under 35 U.S.C. §102 as being anticipated by Minesaki. By this paper, Claim 15 has been amended to incorporate the subject matter of objected-to Claim 19 as discussed *supra*. Accordingly, Patent Owner respectfully submits that Claim 15 as amended herein overcomes the Office’s rejection of Claim 15 as being anticipated by Minesaki and is therefore not anticipated thereby.

4. Per page 40 of the Office Action, Claims 15 – 18 each stand rejected under 35 U.S.C. §102 as being anticipated by Amano. By this paper, Claim 15 has been amended to incorporate the subject matter of objected-to Claim 19 as discussed *supra*. Accordingly, Patent Owner respectfully submits that Claim 15 as amended herein overcomes the Office’s rejection of Claim 15 as being anticipated by Amano and is therefore not anticipated thereby.

25 35 U.S.C. §103

1. Per page 7 of the Office Action, Claim 1 stands rejected under 35 U.S.C. §103 as being unpatentable over Maekawa (Japanese Publication No. JP 04-160991 A, hereinafter “Maekawa”) in view of Amano. In response thereto, Patent Owner provides the following remarks:

Control No. : 90/011,861
Filed : August 16, 2011

5 **Claim 1** – With regards to Claim 1, the Office admits that Maekawa does not specifically disclose monitors that are mounted at the junction of the sidewall and ceiling and directed obliquely downwardly toward the car seats (see page 8 of the Office Action). However, the Office alleges that such a feature is taught by Amano. Furthermore, the Office alleges that Maekawa expressly discloses that the screen of the monitor is substantially flushed with the adjacent wall surface structure of the car, citing features 101 – 124, page 738, column 2, and Figures 1 and 2 of Maekawa. Patent Owner respectfully traverses.

10 Specifically, Maekawa fails to teach or suggest that “*the screen of the monitor [is] substantially flushed with the adjacent wall surface structure of the car*”. Page 738, column 2 of Maekawa states in relevant part: “...*each of the television receivers (101), (102), (103) ... (124) is made low profile using liquid crystal panels or the like.*” Accordingly, while Maekawa clearly contemplates low profile displays, Maekawa is completely silent as to these liquid crystal panels being substantially flushed with the adjacent wall surface structure of the car.

15 Again, the Office alleges that the term “*substantially*” is often used in conjunction with another term to describe a particular characteristic of the claimed invention and is further construed to be a broad term (citing MPEP §2173.05). Again, Patent Owner respectfully submits that the use of the term “*substantially*” cannot be construed so broadly as to read the term “*flushed*” completely out of the claim; see discussion provided *supra*. Figure 2 of Maekawa illustrates that no part of these low profile displays are “*flush*” with the adjacent wall surface structure of the car as
20 Patent Owner has used that term in its specification and Claim 1. Figure 2 of Maekawa is reproduced below for the convenience of the Office.

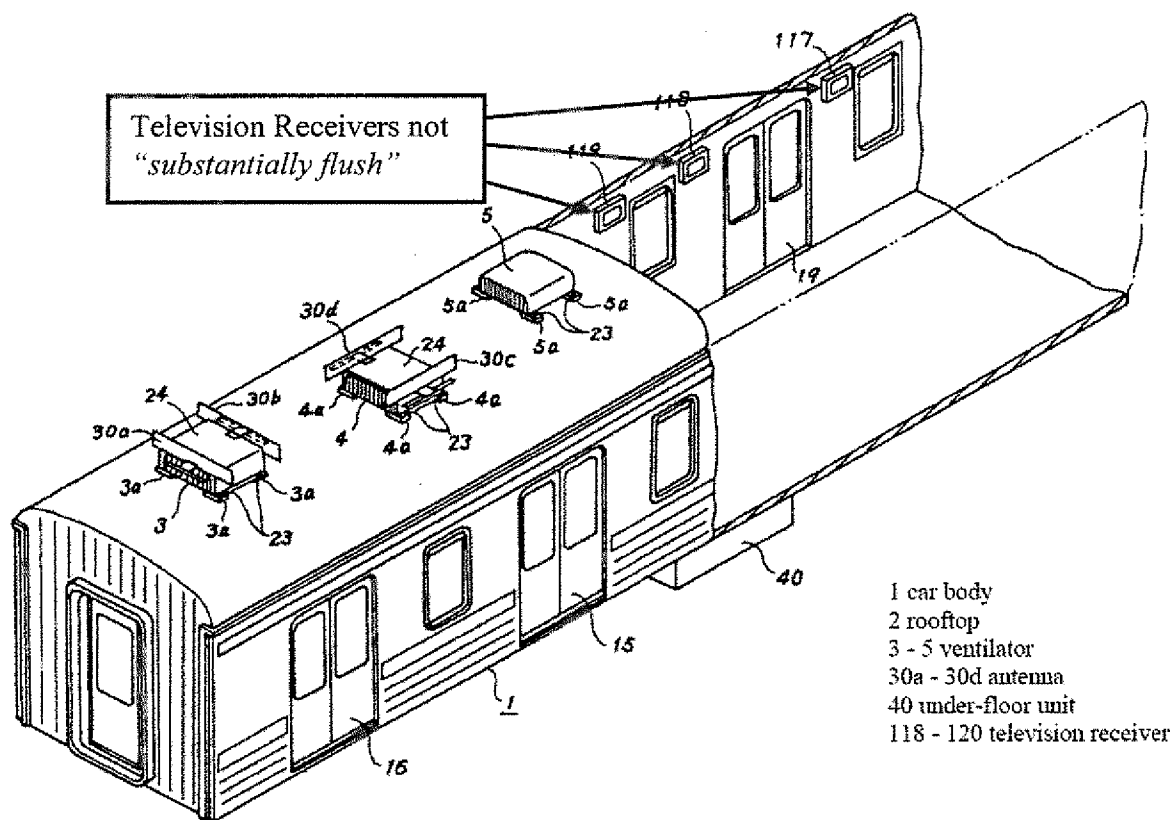

Figure 2 of Maekawa

As can be seen, there is not a single part of the television receiver illustrated in Figure 2 (including especially its screen) that is flush with the adjacent wall surface structure of the car; in fact, the entire television receiver of Maekawa clearly protrudes from the adjacent car wall surface. Accordingly, Patent Owner respectfully submits that the Office's interpretation of the term "substantially flushed" is improper, as the Office's interpretation completely reads out the "flushed" feature.

Patent Owner further submits that Amano does not cure the deficiencies present in Maekawa (see discussion of Amano with regards to the Office's 35 U.S.C. § 102 rejection above).

In response to Patent Owner's previous assertions, the Office states that the term flush is "examined as 'forming a continuous plane or unbroken surface.'" Furthermore, the Office alleges that the screen of the display monitor illustrated in FIG. 4a above can never form a continuous plane or unbroken surface with the adjacent wall surface structure. However, the Office alleges that this is the case because the screen is further behind the transport screen of the enclosure (see page

Control No. : 90/011,861
Filed : August 16, 2011

112 of the *Ex Parte* Office Action). Patent Owner submits that although the screen of the monitor is behind the transport screen, the use of the transport screen would give the appearance of a flush mounted monitor (“*substantially flush*”), even though the screen of the monitor would actually be slightly offset from the adjacent wall surface structure of the car. Again, contrast with Maekawa which illustrates information display devices which would clearly not give the appearance of a flush mounted monitor.

Accordingly, the Office’s rejection of Claim 1 as being obvious over Maekawa in view of Amano is respectfully improper and should be withdrawn.

10 2. Per page 10 of the Office Action, Claim 1 stands rejected under 35 U.S.C. §103 as being unpatentable over Minesaki in view of Moore et al. (U.S. Patent No. 3,480,727, hereinafter “Moore”). In response thereto, Patent Owner provides the following remarks:

15 **Claim 1** – Patent Owner respectfully traverses the Office’s contention that Claim 1 is obvious over Minesaki in view of Moore. Specifically, and as discussed previously herein with regards to Patent Owner’s discussion of Minesaki *supra*, Minesaki fails to teach or suggest: (1) “*each of said monitor being mounted at the junction of the sidewall and ceiling*”; and (2) “*directed obliquely downwardly toward the car seats*”.

20 Furthermore, Patent Owner submits that Moore does not cure the deficiencies found in Minesaki, as Moore is only being utilized for its teaching of a monitor adapted to be mounted flush with a surrounding wall, and teaches nothing of the placement of the monitor within the wall (e.g., at a junction or otherwise).

Accordingly, Patent Owner respectfully submits that the Office’s rejection of Claim 1 as being unpatentable over Minesaki in view of Moore is improper and should be withdrawn.

25 3. Per page 13 of the Office Action, Claim 1 stands rejected under 35 U.S.C. §103 as being unpatentable over Amano in view of Moore. In response thereto, Patent Owner provides the following remarks:

Control No. : 90/011,861
Filed : August 16, 2011

5 **Claim 1** – Patent Owner respectfully traverses the Office’s rejection of Claim 1 as being unpatentable over Amano in view of Moore. In making the rejection, the Office Action alleges, in part, that it would have been obvious for one of ordinary skill in the art to arrive at “*the screen of the monitor [being] substantially flushed with the adjacent wall surface structure of the car*” by combining the monitors mounted near the junction of the sidewall and ceiling of Amano (see Figures 4 – 6 of Amano) with the teaching of a monitor adapted to be mounted flush with a surrounding wall as taught by Moore. Patent Owner respectfully disagrees and traverses.

MPEP §2143.03(VI) states that: “[a] prior art reference must be considered in its entirety, i.e., as a whole, including portions that would lead away from the claimed invention.”

10 Accordingly, where cited art teaches away from a claimed feature, the cited art is not available for the purposes of an obviousness rejection.

15 Furthermore, if the “*proposed modification would render the prior art invention being modified unsatisfactory for its intended purpose, then there is no suggestion or motivation to make the proposed modification. In re Gordon, 733 F.2d 900, 221 USPQ 1125 (Fed. Cir. 1984)*”. See also MPEP §2143.01.

20 In the instant case, Amano fails to teach or suggest “*the screen of the monitor [being] substantially flushed with the adjacent wall surface structure of the car*”. However, the Office states that the monitor of Amano can readily and predictably be substituted with the flush monitor of Moore. To the contrary, Patent Owner respectfully submits that the wall structure of Amano (in particular, the area near the junction of the sidewall and ceiling) would need to be appreciably modified in order to accommodate a flush monitor. See also, for example, FIG. 4a of the ‘602 Patent. However, Amano also illustrates storage areas on the upper areas of the train. See for example, Figure 4 of Amano reproduced below.

Figure 4

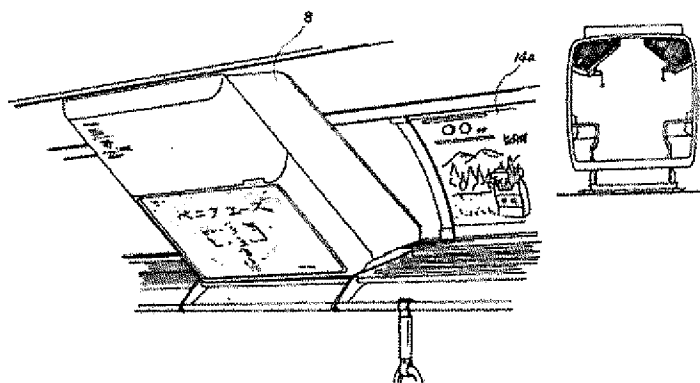

Figure 4 of Amano

Accordingly, modifications to the area near the junction of the sidewall and ceiling of the Amano train would render the Amano train unsatisfactory for its intended purpose. For example, if the wall surface structure near the information display device 8 were to be extended so that the screen of the information display device 8 were "*substantially flushed*" with its adjacent walls, the storage areas would need to be substantially reduced in size or eliminated entirely. It is not clear to Patent Owner why one would be motivated to make such a modification, where the modification would remove desirable storage area on the train of Amano, thereby leading to a situation where no overhead storage is available for passengers' luggage or other items. By analogy, one would not design a commercial airliner such that no overhead storage was available (thereby requiring passengers to check all baggage).

Note also that the cross-sectional view in FIG. 4 of Amano reproduced above shows a thin outer shell or body for the train car with seemingly little or no interior volume of space, thereby frustrating mounting of the monitor screen flush therewith (otherwise, the back of the monitor, wiring, etc, would protrude through the car body and be exposed on the outside), which is clearly undesirable.

Furthermore, it is a stated purpose of Amano to take the opportunity to effectively use the time on a transportation vehicle to provide various information to people who are using various cited transportation vehicles (i.e., airplane, train and bus). Accordingly, if Amano were modified so that the display devices 8 were flush with the adjacent wall surface structure of the car, and the storage areas were modified to protrude further away from the sidewall to accommodate for the space taken up by the flush mounted monitors, passengers would place

Control No. : 90/011,861
Filed : August 16, 2011

luggage or other articles onto these storage areas thereby obscuring the display of information on these display devices from the passengers on the transportation vehicle, in direct contravention with the stated purpose of Amano.

5 Amano does not appear to explicitly describe the reasoning behind the placement of the information signal display devices near the junction of the ceiling and the sidewall. However, it appears reasonable to infer that since each of the respective embodiments which illustrate this feature (i.e. FIGS. 4 – 6) also include areas for overhead storage, that the placement of the information signal display devices is merely necessitated because of the existence of these overhead storage areas; i.e., they would not otherwise be able to be accommodated on the
10 sidewall areas as illustrated in, for example, Maekawa, as the overhead storage areas interface with the sidewall in these traditional information signal display device mounting areas.

Therefore, as the proposed modification to Amano would render the Amano storage areas (or information display devices 8) unsatisfactory for their intended purpose, one of ordinary skill in the art would not be motivated to modify Amano to incorporate certain features
15 of Moore in an effort to arrive at the claimed invention. Accordingly, Patent Owner respectfully submits that the rejection is improper and respectfully requests that the rejection be withdrawn.

4. Per page 17 of the Office Action, Claim 1 stands rejected under 35 U.S.C. §103 as being unpatentable over Maekawa in view of Amano and further in view of Moore. Furthermore,
20 per pages 20 – 21 of the Office Action, Claim 1 stands rejected under 35 U.S.C. §103 as being unpatentable over Shinagawa et al. (Japanese Publication No. JP 04-160991 A, hereinafter “Shinagawa”) in view of Amano and further in view of Moore. In response thereto, Patent Owner provides the following remarks:

25 **Claim 1** – In each of these respective instances, Maekawa and Shinagawa are both alleged to disclose all of the limitations of the claimed invention, except for specifically calling for each of the monitors to be mounted at the junction of the sidewall and ceiling and directed obliquely downwardly toward the car seats, with the screen of the monitor being substantially flushed with the adjacent wall surface structure. However, the Office utilizes Amano in combination with
30 Moore to allegedly teach such features as claimed.

Control No. : 90/011,861
Filed : August 16, 2011

However, as discussed previously herein, Patent Owner respectfully submits that the proposed combination of Amano and Moore is improper, as the modification of Amano to include the flush monitors of Moore would render the Amano storage areas (or information display devices 8) unsatisfactory for their intended purpose. Accordingly, as the proposed modification
5 would render the “*prior art invention being modified unsatisfactory for its intended purpose ... there is no suggestion or motivation to make the proposed modification*”.

Patent Owner respectfully requests withdrawal of the Office’s rejection of Claim 1 as being unpatentable over Maekawa in view of Amano and further in view of Moore; or alternatively as being unpatentable over Shinagawa in view of Amano and further in view of Moore.

10

5. Per page 47 of the Office Action, Claims 15 – 18 each stand rejected under 35 U.S.C. § 103 as being unpatentable over Maekawa in view of Amano. By this paper, Claim 15 has been amended to incorporate the subject matter of objected-to Claim 19 as discussed *supra*. Accordingly, Patent Owner respectfully submits that Claim 15 as amended herein overcomes the
15 Office’s rejection of Claim 15 as being unpatentable over Maekawa in view of Amano and is therefore not rendered obvious thereby.

6. Per page 56 of the Office Action, Claims 15 – 18 each stand rejected under 35 U.S.C. § 103 as being unpatentable over Minesaki in view of Moore. By this paper, Claim 15 has
20 been amended to incorporate the subject matter of objected-to Claim 19 as discussed *supra*. Accordingly, Patent Owner respectfully submits that Claim 15 as amended herein overcomes the Office’s rejection of Claim 15 as being unpatentable over Minesaki in view of Moore and is therefore not rendered obvious thereby.

7. Per page 65 of the Office Action, Claims 15 – 18 each stand rejected under 35 U.S.C. § 103 as being unpatentable over Amano in view of Moore. By this paper, Claim 15 has
25 been amended to incorporate the subject matter of objected-to Claim 19 as discussed *supra*. Accordingly, Patent Owner respectfully submits that Claim 15 as amended herein overcomes the Office’s rejection of Claim 15 as being unpatentable over Amano in view of Moore and is
30 therefore not rendered obvious thereby.

Control No. : 90/011,861
Filed : August 16, 2011

8. Per page 75 of the Office Action, Claims 15 – 18 each stand rejected under 35 U.S.C. § 103 as being unpatentable over Maekawa in view of Amano and Moore. By this paper, Claim 15 has been amended to incorporate the subject matter of objected-to Claim 19 as discussed
5 *supra*. Accordingly, Patent Owner respectfully submits that Claim 15 as amended herein overcomes the Office’s rejection of Claim 15 as being unpatentable over Maekawa in view of Amano and Moore and is therefore not rendered obvious thereby.

9. Per page 87 of the Office Action, Claims 15 – 18 each stand rejected under 35
10 U.S.C. § 103 as being unpatentable over Shinagawa in view of Amano and Moore. By this paper, Claim 15 has been amended to incorporate the subject matter of objected-to Claim 19 as discussed *supra*. Accordingly, Patent Owner respectfully submits that Claim 15 as amended herein overcomes the Office’s rejection of Claim 15 as being unpatentable over Shinagawa in view of Amano and Moore and is therefore not rendered obvious thereby.

15

Other Remarks

Patent Owner notes that any remarks made with respect to a given claim or claims are limited solely to such claim or claims, unless otherwise explicitly noted.

If the Examiner has any questions or comments which may be resolved over the
20 telephone, he is respectfully requested to call the undersigned at (858) 675-1670.

Respectfully submitted,

GAZDZINSKI & ASSOCIATES, PC

25

Dated: June 25, 2012

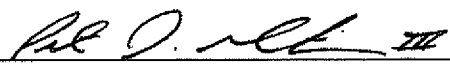
By: 
Peter J. Gutierrez, III
Registration No. 56,732
16644 West Bernardo Drive, Suite 201
San Diego, CA 92127
Telephone No.: (858) 675-1670
Facsimile No.: (858) 675-1674

30

Electronic Acknowledgement Receipt

EFS ID:	13095784
Application Number:	90011861
International Application Number:	
Confirmation Number:	3736
Title of Invention:	SUBWAY TV MEDIA SYSTEM
First Named Inventor/Applicant Name:	6700602
Customer Number:	27299
Filer:	Peter John Gutierrez III/Carrie DeCoro
Filer Authorized By:	Peter John Gutierrez III
Attorney Docket Number:	BLAIR.001A
Receipt Date:	25-JUN-2012
Filing Date:	16-AUG-2011
Time Stamp:	15:10:17
Application Type:	Reexam (Patent Owner)

Payment information:

Submitted with Payment	no
------------------------	----

File Listing:

Document Number	Document Description	File Name	File Size(Bytes)/ Message Digest	Multi Part /.zip	Pages (if appl.)
1	Trans Letter filing of a response in a reexam	BLAIR_001A_Transmittal.pdf	42106 <small>d7286062f27c7b3b2891a36ff5bbd5cdccf247ce</small>	no	2

Warnings:

Information:

2	Reexam Response to Final Rejection	BLAIR_001A_Response.pdf	980415	no	23
			4ddafeb7735e36e1b6a68e6e0afd5502ff245c1		

Warnings:

Information:

Total Files Size (in bytes):	1022521
-------------------------------------	---------

This Acknowledgement Receipt evidences receipt on the noted date by the USPTO of the indicated documents, characterized by the applicant, and including page counts, where applicable. It serves as evidence of receipt similar to a Post Card, as described in MPEP 503.

New Applications Under 35 U.S.C. 111

If a new application is being filed and the application includes the necessary components for a filing date (see 37 CFR 1.53(b)-(d) and MPEP 506), a Filing Receipt (37 CFR 1.54) will be issued in due course and the date shown on this Acknowledgement Receipt will establish the filing date of the application.

National Stage of an International Application under 35 U.S.C. 371

If a timely submission to enter the national stage of an international application is compliant with the conditions of 35 U.S.C. 371 and other applicable requirements a Form PCT/DO/EO/903 indicating acceptance of the application as a national stage submission under 35 U.S.C. 371 will be issued in addition to the Filing Receipt, in due course.

New International Application Filed with the USPTO as a Receiving Office

If a new international application is being filed and the international application includes the necessary components for an international filing date (see PCT Article 11 and MPEP 1810), a Notification of the International Application Number and of the International Filing Date (Form PCT/RO/105) will be issued in due course, subject to prescriptions concerning national security, and the date shown on this Acknowledgement Receipt will establish the international filing date of the application.

IN THE UNITED STATES PATENT AND TRADEMARK OFFICE

Patentee : Scott Blair)
 Patent No. : 6,700,602 – Issued 03/02/04)
 Control No. : 90/011,861)
 Filed : August 16, 2011)
 For : **SUBWAY TV MEDIA SYSTEM**)
 Examiner : Stephen Ralis)
 Group Art Unit: 3992)



27299
PATENT TRADEMARK OFFICE

CERTIFICATE OF ELECTRONIC
(EFS-WEB) TRANSMISSION

I hereby certify that this correspondence is being transmitted via the Office electronic filing system in accordance with 37 C.F.R. § 1.8(a)(i)(C) from the Pacific Time Zone of the United States on the local date shown below.

Dated: June 25, 2012

By:
Peter J. Gutierrez, III, Reg. No. 56,732

TRANSMITTAL LETTER – EX PARTE REEXAMINATION

Mail Stop *Ex Parte* Reexam
Central Reexamination Unit
Commissioner for Patents
United States Patent & Trademark Office
P.O. Box 1450
Alexandria, VA 22313-1450

Sir:

Transmitted herewith in the above-entitled Ex Parte Reexamination application are the following:

1. Response to Final Office Action – Ex Parte Reexamination (23 Pages).

Control No. : 90/011,861
Filed : August 16, 2011

The fee has been calculated as shown below:

EX PARTE REEXAMINATION CLAIMS AS FILED

	CLAIMS REMAINING AFTER RESPONSE		HIGHEST NO. PREVIOUSLY PAID FOR	PRESENT EXTRA	RATE	ADDITIONAL FEE
Total Claims	29	MINUS	30	= 0 X	\$ 30	= \$0
Independent Claims	4	MINUS	4	= 0 X	\$125	= \$0
TOTAL ADDITIONAL FEE FOR THIS APPLICATION						\$0.00

The Commissioner is hereby authorized to charge any fees which may be required to Deposit Account No. 501423.

Respectfully submitted,

GAZDZINSKI & ASSOCIATES, PC

Dated: June 25, 2012

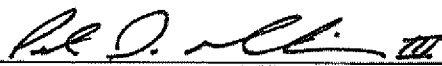
By: 
Peter J. Gutierrez, III
Registration No. 56,732
16644 West Bernardo Drive, Suite 201
San Diego, CA 92127
Telephone No.: (858) 675-1670
Facsimile No.: (858) 675-1674

Litigation Search Report CRU 3999

Reexam Control No. 90/011,861

TO: Stephen Ralis
Location: CRU
Art Unit: 3992
Date: 12/31/2012

From: Patricia Volpe
Location: CRU 3999
MDE 5D30
Phone: (571) 272-6825
Patricia.volpe@uspto.gov

Search Notes

Litigation search for U.S. Patent Number: 6,700,602

- 1) I performed a KeyCite Search in Westlaw, which retrieves all history on the patent including any litigation.
- 2) I performed a search on the patent in Lexis CourtLink for any open dockets or closed cases.
- 3) I performed a search in Lexis in the Federal Courts and Administrative Materials databases for any cases found.
- 4) I performed a search in Lexis in the IP Journal and Periodicals database for any articles on the patent.
- 5) I performed a search in Lexis in the news databases for any articles about the patent or any articles about litigation on this patent.

KEYCITE**C US PAT 6700602 SUBWAY TV MEDIA SYSTEM, (Mar 02, 2004)****History****Direct History**

=> 1 **SUBWAY TV MEDIA SYSTEM**, US PAT 6700602, 2004 WL 380060 (U.S. PTO Utility Mar 02, 2004)

Patent Family

2 **SUBWAY TV MEDIA SYSTEM E.G. FOR PUBLIC SERVICE MESSAGE DISPLAY HAS SEVERAL TV MONITORS MOUNTED AT INTERVALS ALONG CARS AT JUNCTION OF SIDEWALL AND CEILING WITH CENTRAL VIDEO SIGNAL SOURCE CONNECTED TO VIDEO MONITORS AND PROGRAMS OF SHORT DURATION ARE PLAYED AND DISPLAYED ON MONITORS**, Derwent World Patents Legal 1998-610758+

Patent Status Files

.. Request for Re-Examination, (OG DATE: Oct 04, 2011)

Prior Art (Coverage Begins 1976)

- C** 4 **AIRCRAFT PASSENGER ENTERTAINMENT SYSTEM**, US PAT 4352124 Assignee: Bell & Howell Company, (U.S. PTO Utility 1982)
- C** 5 **AIRCRAFT PASSENGER TELEVISION SYSTEM**, US PAT 4647980 Assignee: Aviation Entertainment Corporation, (U.S. PTO Utility 1987)
- C** 6 **AUTOMATED MERCHANDISING SYSTEM**, US PAT 4073368 (U.S. PTO Utility 1978)
- C** 7 **AUTOMATIC ADVERTISING STATION ANNOUNCING SYSTEM AND METHOD**, US PAT 1894684 (U.S. PTO Utility 1933)
- C** 8 **BILLBOARD DEVICE**, US PAT 5229910 Assignee: Abisare Co., Ltd., (U.S. PTO Utility 1993)
- C** 9 **DEVICE FOR INTERFACING A CD-ROM PLAYER TO AN ENTERTAINMENT OR INFORMATION NETWORK AND A NETWORK INCLUDING SUCH DEVICE**, US PAT 5666291 Assignee: Sony Corporation; Sony Trans Com Inc., (U.S. PTO Utility 1997)
- C** 10 **DISPLAY APPARATUS FOR VEHICLE**, US PAT 5059957 Assignee: Nissan Motor Company, Limited, (U.S. PTO Utility 1991)
- C** 11 **DISPLAY DEVICE**, US PAT 5463827 Assignee: Hanover Displays Limited, (U.S. PTO Utility 1995)
- C** 12 **OVERHEAD SUPPORT SYSTEM FOR TV MONITORS**, US PAT 5009384 Assignee: Inter-Link Communciations Inc., (U.S. PTO Utility 1991)

- C** 13 PROJECTION STATION, US PAT 3457006 Assignee: BELL + HOWELL COMPANY, (U.S. PTO Utility 1969)
- C** 14 REAR SCREEN VIDEO PROJECTION SYSTEM FOR AIRCRAFT PASSENGER ENTERTAINMENT, US PAT 5123728 Assignee: Sony Trans Com, Inc., (U.S. PTO Utility 1992)
- C** 15 SYSTEM AND METHOD FOR PROCESSING PASSENGER SERVICE SYSTEM INFORMATION, US PAT 5854591 Assignee: Sony Trans Com, Inc.; Sony Corporation, (U.S. PTO Utility 1998)
- C** 16 SYSTEM AND METHOD FOR SECURING A REMOVABLE SEAT ELECTRONICS UNIT WITHOUT DETACHMENT OF THE COMMUNICATION CABLE, US PAT 6038426 Assignee: Sony Corporation; Sony Trans Com, Inc., (U.S. PTO Utility 2000)
- C** 17 TAXICAB ADVERTISING DEVICE, US PAT 3182550 (U.S. PTO Utility 1965)
- C** 18 TIMED ADVERTISING IN ELEVATORS AND OTHER SHUTTLES, US PAT 5606154 Assignee: Otis Elevator Company, (U.S. PTO Utility 1997)
- C** 19 VIDEO GAME APPARATUS INTEGRAL WITH AIRPLANE PASSENGER SEAT TRAY, US PAT 4630821 Assignee: Aero-Vision Systems, Inc., (U.S. PTO Utility 1986)

Single Search - with Terms and Connectors

Enter keywords - Search multiple dockets & documents

Search

[View Demo](#)
[Search Tips](#)

[My CourtLink](#)

[Search](#)

[Dockets & Documents](#)

[Track](#)

[Alert](#)

[Strategic Profiles](#)

[My Account](#)



[Search](#) > [Patent Search](#) > [Searching](#)

Patent Search 6700602 1/3/2013 (1)

No cases found.

[Return to Search](#)

(Charges for search still apply)



[About LexisNexis](#) | [Terms & Conditions](#) | [Pricing](#) | [Privacy](#) | [Customer Support](#) - 1-888-311-1966
Copyright © 2013 LexisNexis®. All rights reserved.

423284 (09) 6700602 March 2, 2004

UNITED STATES PATENT AND TRADEMARK OFFICE GRANTED PATENT

6700602

Get Drawing Sheet 1 of 6
Access PDF of Official Patent *
Order Patent File History / Wrapper from REEDFAX®
Link to Claims Section

March 2, 2004

Subway TV media system

REEXAM-LITIGATE:

Reexamination requested August 16, 2011 by PATENT OWNER, Reexamination No. 90/011,861 (O.G. October 4, 2011) Ex. Gp.: 3992 August 16, 2011

INVENTOR: Blair, Scott - 32 Marlow Avenue, Toronto, Ontario, Canada (CA), M4J 3T9

APPL-NO: 423284 (09)

FILED-DATE: February 22, 2000

GRANTED-DATE: March 2, 2004

LEGAL-REP: Nixon Peabody LLP ; Costellia, Jeffrey L.

PRIM-EXMR: Kelley, Chris

ASST-EXMR: Wong, Allen

CORE TERMS: monitor, subway cars, video, display, car, passenger, television, advertising, subway, video signal, player, video monitors, screen, enclosure, message, mass transit, intervals, recorder, duration, ceiling, digital, panel, transit systems, subway system, computer-based, entertainment, mounting, suitably, minute, windows

NO-OF-CLAIMS: 7

Source: [Legal > / . . . / > Utility, Design and Plant Patents](#) 

Terms: **PATNO=6700602** (Suggest Terms for My Search)

View: Custom

Segments: Appl-no, Assignee, Cert-correction, Date, Exmr, Inventor, Legal-rep, Lit-reex, No-of-claims, Patno, Reexam-litigate, Reissue, Reissue-comment

Date/Time: Thursday, January 3, 2013 - 2:34 PM EST

In

About LexisNexis | Privacy Policy | Terms & Conditions | Contact Us
Copyright © 2013 LexisNexis, a division of Reed Elsevier Inc. All rights reserved.



UNITED STATES PATENT AND TRADEMARK OFFICE

UNITED STATES DEPARTMENT OF COMMERCE
United States Patent and Trademark Office
Address: COMMISSIONER FOR PATENTS
P.O. Box 1450
Alexandria, Virginia 22313-1450
www.uspto.gov

APPLICATION NO.	FILING DATE	FIRST NAMED INVENTOR	ATTORNEY DOCKET NO.	CONFIRMATION NO.
90/011,861	08/16/2011	6700602	BLAIR.001A	3736
27299	7590	01/16/2013	EXAMINER	
GAZDZINSKI & ASSOCIATES, PC 16644 WEST BERNARDO DRIVE SUITE 201 SAN DIEGO, CA 92127			RALIS, STEPHEN J	
			ART UNIT	PAPER NUMBER
			3992	
			MAIL DATE	DELIVERY MODE
			01/16/2013	PAPER

Please find below and/or attached an Office communication concerning this application or proceeding.

The time period for reply, if any, is set in the attached communication.



DO NOT USE IN PALM PRINTER

(THIRD PARTY REQUESTER'S CORRESPONDENCE ADDRESS)

GAZDZINSKI & ASSOCIATES, PC
16644 WEST BERNARDO DRIVE
SUITE 201
SAN DIEGO, CA 92127

EX PARTE REEXAMINATION COMMUNICATION TRANSMITTAL FORM

REEXAMINATION CONTROL NO. 90/011,861.

PATENT NO. 6700602.

ART UNIT 3992.

Enclosed is a copy of the latest communication from the United States Patent and Trademark Office in the above identified *ex parte* reexamination proceeding (37 CFR 1.550(f)).

Where this copy is supplied after the reply by requester, 37 CFR 1.535, or the time for filing a reply has passed, no submission on behalf of the *ex parte* reexamination requester will be acknowledged or considered (37 CFR 1.550(g)).

ADVISORY ACTION

Proposed Amendment

After a final rejection in an *ex parte* reexamination filed under § 1.510:

- (1) An amendment may be made canceling claims or complying with any requirement of form expressly set forth in a previous Office action;
- (2) An amendment presenting rejected claims in better form for consideration on appeal may be admitted; or
- (3) An amendment touching the merits of the application or patent under reexamination may be admitted upon a showing of good and sufficient reasons why the amendment is necessary and was not earlier presented. (See 37 CFR § 1.116(b)).

In the proposed amendment filed 25 June 2012 (herein after the "Amendment") by the Patent Owner, claims 8, 9, 15 and 20-23 have been amended, and claim 19 has been canceled. The Amendment presents the claims in better form for consideration on appeal, since the 35 U.S.C. 112, first paragraph, and the 35 U.S.C. 305 rejections have been overcome. Therefore, (2) does apply.

Accordingly, the proposed amendment is entered. As such, this Advisory Action will set forth an identical rejection to the Final Office action for claim 1, mailed 25 April 2012. Therefore, the claim 1 stands previously rejected, as set forth in the Final Rejection mailed on 25 April 2012, and the Examiner's Response to Arguments

Art Unit: 3992

presented in the Final Rejection mailed on 25 April 2012, which is hereby incorporated by reference, is maintained, as set forth below.

REMARKS

Owners Arguments

Issue 1: Rejections under 35 under 35 U.S.C. 102(b) by Minesaki

With respect to Owners reply/argument that Minesaki fails to expressly or inherently describe “each of said monitor being mounted at the junction of the sidewall and ceiling”, the examiner respectfully disagrees. As Owner has noted, Minesaki discloses

This information transmission display part J may also be formed on the sidewall of the train car (page 590, right upper most column).

Minesaki further discloses such a configuration in the annotated Figure 2, as shown below

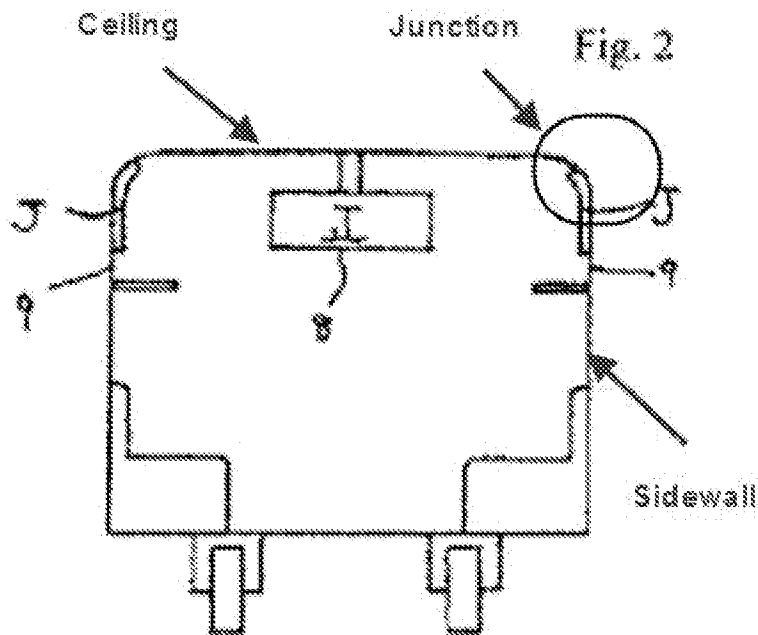

In the annotated Figure 2 above, Minesaki illustrates a ceiling portion, a sidewall portion, and a junction portion between the respective sidewall and ceiling portions (see above). In addition, the monitor (information transmission display part **J**) is clearly partially mounted and disposed in the junction portion between the respective sidewall and ceiling portions. Therefore, Minesaki fully meets “each of said monitor being mounted at the junction of the sidewall and ceiling” given its broadest reasonable interpretation.

With respect to Owners reply/argument that Minesaki fails to expressly or inherently describe “with the screen of the monitor substantially flushed with the adjacent wall surface structure of the car”, the examiner respectfully disagrees. Although the claims are interpreted in light of the specification, limitations from the

Art Unit: 3992

specification are not read into the claims. See *In re Van Geuns*, 988 F.2d 1181, 26 USPQ2d 1057 (Fed. Cir. 1993).

In that regard, it is improper to import claim limitations from the specification. “Although claims of issued patents are interpreted in light of the specification, prosecution history, prior art and other claims, this is not the mode of claim interpretation to be applied during examination. During examination, the claims must be interpreted as broadly as their terms reasonably allow” (see MPEP § 2111). “Though understanding the claim language may be aided by explanations contained in the written description, it is important not to import into a claim limitations that are not part of the claim. For example, a particular embodiment appearing in the written description may not be read into a claim when the claim language is broader than the embodiment” (again see MPEP § 2111).

As asserted in the previous Office action

(T)he term “substantially” is often used in conjunction with another term to describe a particular characteristic of the claimed invention. It is a broad term. (See MPEP 2173.05).

The recitation to “flush” is modified by the term “substantially” which essentially broadens the recitation of “flush”. The term “flush” is examined as “forming a continuous plane or unbroken surface.”¹ The limitation of “substantially flushed” recites the screen of the monitor not forming a continuous plane or unbroken surface, but to the screen not wholly forming a continuous plane or unbroken surface with the adjacent wall surface structure. Owner discloses

¹ “flush.” Merriam-Webster Online Dictionary. 2012. Merriam-Webster Online. 10 April 2012 <<http://www.merriam-webster.com/dictionary/flush>>

Art Unit: 3992

An alternative embodiment is illustrated in FIG. 4A, a view similar to that of FIG. 4. In this alternative embodiment, CRT video monitor **22** is replaced with an LCD-based video monitor **22A** which is of thin, rectangular cross-section, and occupies less space in the ceiling structure of the car. Accordingly, it can be moved towards the ceiling so that its viewing screen is substantially flush with or even behind the light panel **40**. This use of an LCD-based monitor gives a better aesthetic appearance to the inside of the subway car as a whole, as well as improving the display performance by minimizing the interference effects, as previously discussed. (Page 5, lines 35-46)

Included below is Figure 4A.

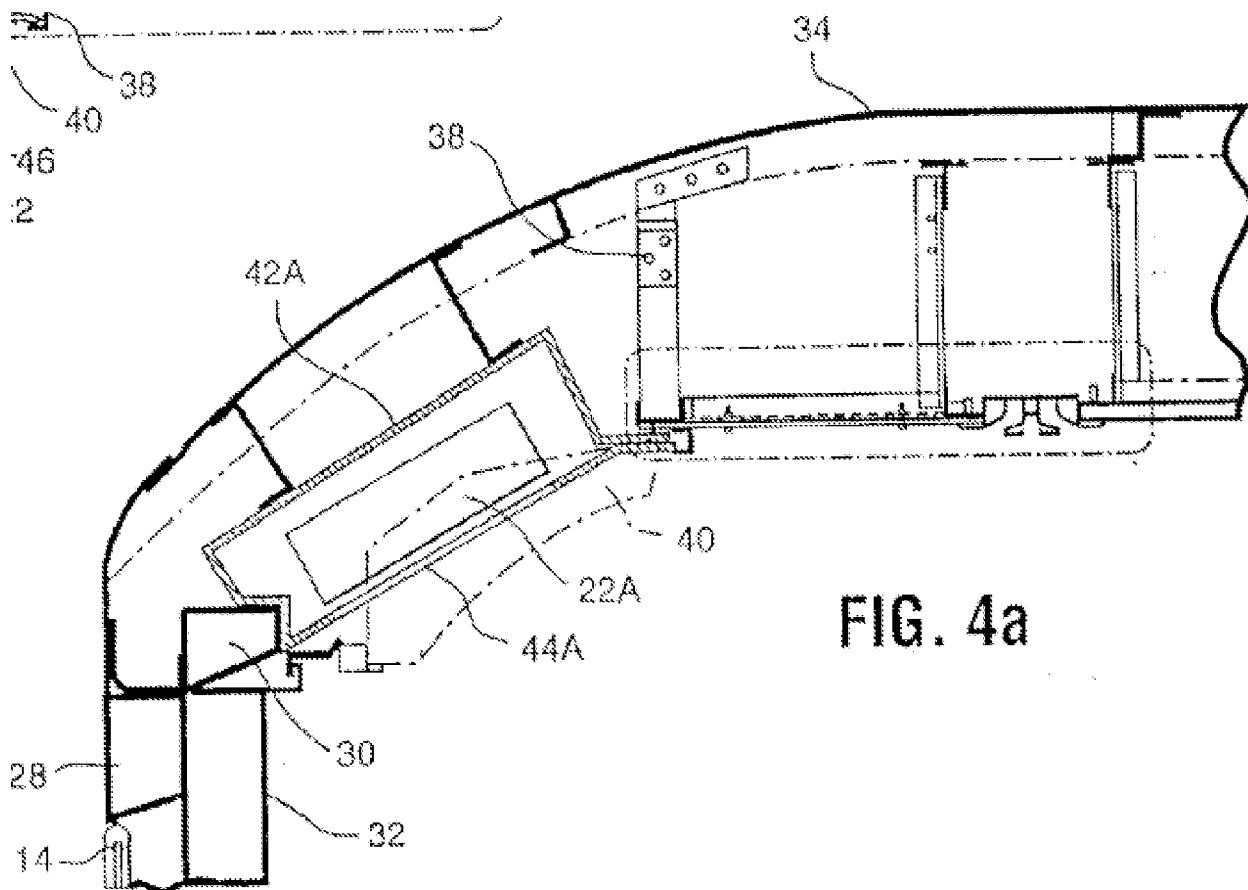

As asserted above, the

“CRT video monitor is replaced with an LCD-based video monitor **22A** which is of thin, rectangular cross-section, and occupies less space in the ceiling structure of the car”.

In Figure 4A, Owner explicitly discloses the monitor **22A** being behind the light panel **40** (see Figure 4A above). Owner alludes to the monitor **22A** being “substantially flush”, however, never provides explicit disclosure of the embodiment. Moreover, after further examination of Figure 4A, the actual viewing screen of the monitor **22A** can never really be flush with the light panel since the screen of the monitor **22A** is further behind the transport screen **44A** of the appropriately shaped enclosure **42A**, hence there is an actual space and/or distance between the actual viewing screen of the monitor **22A** and the transport screen **44A** of the appropriately shaped enclosure **42A**. Furthermore, Owner never defines the term “flushed” and only alludes to the disclosure of “substantially flushed” in light of Figure 4A. Figure 4A clearly does not show the embodiment of the screen being “flushed” with the adjacent wall surface structure and, additionally provides evidence to the fact that screen of the display monitor can never form a continuous plane or unbroken surface with the adjacent wall surface structure, but can only form a surface that is offset therefrom or “substantially flushed”, in light of the Owner's instant disclosure.

In that light, Minesaki clearly discloses a “liquid crystal panel”, **J**, being formed on the sidewall **9** and such a “liquid crystal panel” would have a low profile, as shown above. A “liquid crystal panel” would never be really flush with the sidewall, however, the “liquid crystal panel”, **J**, would be “substantially flush”, or offset therefrom, in light of the instant Owner's disclosure. Therefore, Minesaki clearly discloses “the screen of the monitor (being) *substantially flushed* with the adjacent wall surface structure of the car” given its broadest reasonable interpretation.

Art Unit: 3992

With respect to Owners reply/argument that Minesaki fails to expressly or inherently describe “the screen of the monitor... (is) directed obliquely downward toward the car seats”, the examiner respectfully disagrees. The Owner further argues that the recitation to “the screen of the monitor...(is) directed obliquely downward toward the car seats” does not include prior art in which “only portions of the screen of the monitor are directed obliquely downwardly”. It is noted that the features upon which applicant relies (i.e. the total screen of the monitor being directed obliquely downward toward the car seats) are not recited in the rejected claim(s). Although the claims are interpreted in light of the specification, limitations from the specification are not read into the claims. See *In re Van Geuns*, 988 F.2d 1181, 26 USPQ2d 1057 (Fed. Cir. 1993).

In that regard, it is improper to import claim limitations from the specification. “Although claims of issued patents are interpreted in light of the specification, prosecution history, prior art and other claims, this is not the mode of claim interpretation to be applied during examination. During examination, the claims must be interpreted as broadly as their terms reasonably allow” (see MPEP § 2111). “Though understanding the claim language may be aided by explanations contained in the written description, it is important not to import into a claim limitations that are not part of the claim. For example, a particular embodiment appearing in the written description may not be read into a claim when the claim language is broader than the embodiment” (again see MPEP § 2111).

It is asserted by the examiner that Owner has conceded that

Art Unit: 3992

“Patent Owner admits that the information transmission display parts J of Minesaki appear curved with the top portion seemingly directed obliquely downwardly...” (page 8, lines 18-19).

Minesaki clearly discloses portions of the screen of the monitor **J** being directed obliquely downward toward the car seats, as is evidenced by Figure 2. Claim 1 further recites,

the monitors being... directed obliquely downward, **so that each video screen is readily visible to passengers in the subway car.** (Emphasis added).

In examination of Figure 2, any user of the Minesaki subway car, either sitting in the seats provided or standing, would be able to view the monitors from an obliquely oriented perspective.

Therefore, since portions of the monitor screen of Minesaki are directed obliquely downward toward the car seats, Minesaki fully meets “the screen of the monitor...(is) directed obliquely downward toward the car seats, so that each video screen is readily visible to passengers in the subway car” given its broadest reasonable interpretation.

Issue 2: Rejections under 35 U.S.C. 102(b) by Amano et al

With respect to Owners reply/argument that Amano et al. fails to expressly or inherently describe “with the screen of the monitor substantially flushed with the adjacent wall surface structure of the car”, the examiner respectfully disagrees. Although the claims are interpreted in light of the specification, limitations from the specification are not read into the claims. See *In re Van Geuns*, 988 F.2d 1181, 26 USPQ2d 1057 (Fed. Cir. 1993).

In that regard, it is improper to import claim limitations from the specification. “Although claims of issued patents are interpreted in light of the specification, prosecution history, prior art and other claims, this is not the mode of claim interpretation to be applied during examination. During examination, the claims must be interpreted as broadly as their terms reasonably allow” (see MPEP § 2111). “Though understanding the claim language may be aided by explanations contained in the written description, it is important not to import into a claim limitations that are not part of the claim. For example, a particular embodiment appearing in the written description may not be read into a claim when the claim language is broader than the embodiment” (again see MPEP § 2111).

As asserted in the previous Office action

(T)he term “substantially” is often used in conjunction with another term to describe a particular characteristic of the claimed invention. It is a broad term. (See MPEP 2173.05).

The recitation to “flush” is modified by the term “substantially” which essentially broadens the recitation of “flush”. The term “flush” is examined as “forming a continuous plane or unbroken surface.”² The limitation of “substantially flushed” recites the screen of the monitor not forming a continuous plane or unbroken surface, but to the screen *not wholly forming* a continuous plane or unbroken surface with the adjacent wall surface structure. Owner discloses

An alternative embodiment is illustrated in FIG. 4A, a view similar to that of FIG. 4. In this alternative embodiment, CRT video monitor 22 is replaced with an LCD-based video monitor 22A which is of thin, rectangular cross-section, and

² “flush.” Merriam-Webster Online Dictionary. 2012. Merriam-Webster Online. 10 April 2012 <<http://www.merriam-webster.com/dictionary/flush>>

Art Unit: 3992

occupies less space in the ceiling structure of the car. Accordingly, it can be moved towards the ceiling so that its viewing screen is substantially flush with or even behind the light panel 40. This use of an LCD-based monitor gives a better aesthetic appearance to the inside of the subway car as a whole, as well as improving the display performance by minimizing the interference effects, as previously discussed. (Page 5, lines 35-46)

Included below is Figure 4A.

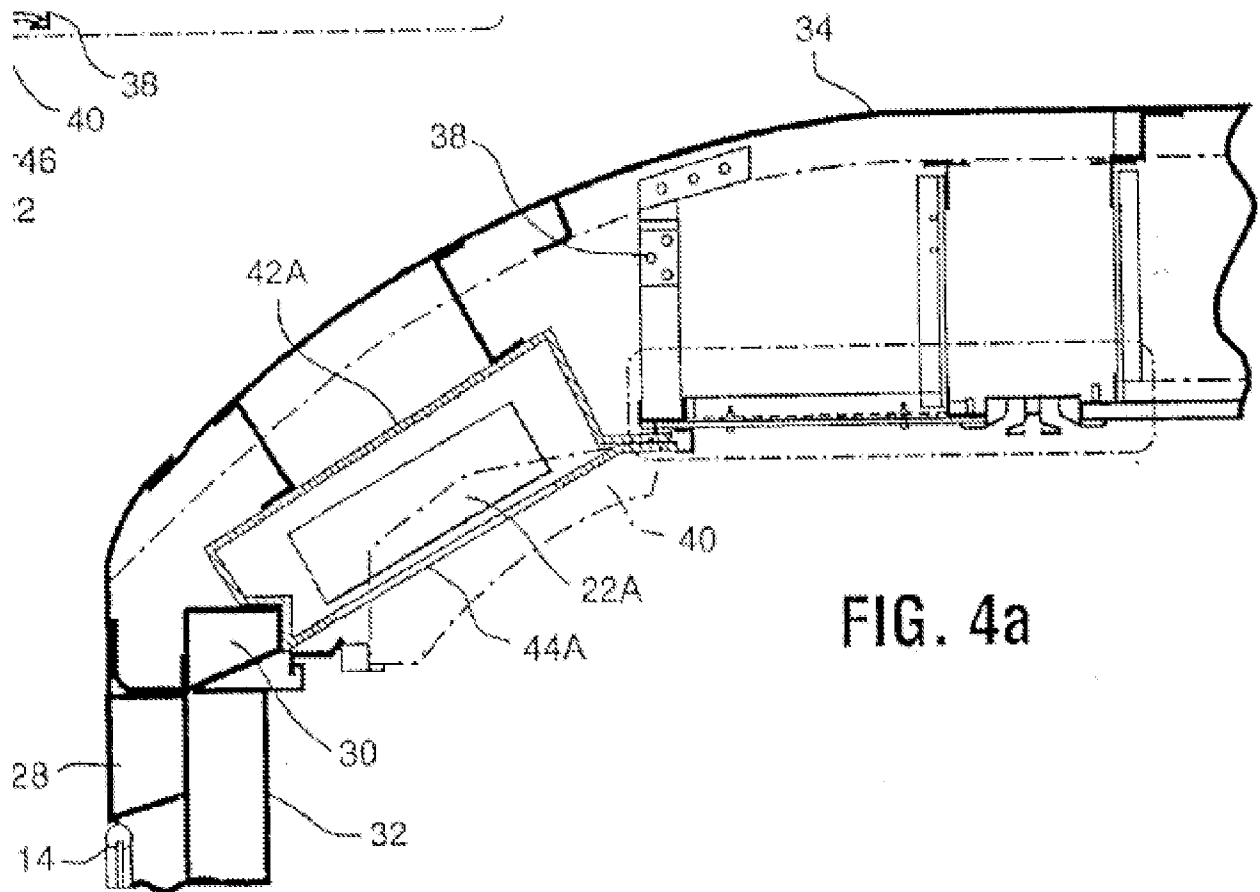

FIG. 4a

As asserted above, the

*“CRT video monitor is replaced with an LCD-based video monitor **22A** which is of thin, rectangular cross-section, and occupies less space in the ceiling structure of the car”.*

Art Unit: 3992

In Figure 4A, Owner explicitly discloses the monitor **22A** being behind the light panel **40** (see Figure 4A above). Owner alludes to the monitor **22A** being “substantially flush”, however, never provides explicit disclosure of the embodiment. Moreover, after further examination of Figure 4A, the actual viewing screen of the monitor **22A** can never really be flush with the light panel since the screen of the monitor **22A** is further behind the transport screen **44A** of the appropriately shaped enclosure **42A**, hence there is an actual space and/or distance between the actual viewing screen of the monitor **22A** and the transport screen **44A** of the appropriately shaped enclosure **42A**. Furthermore, Owner never defines the term “flushed” and only alludes to the disclosure of “substantially flushed” in light of Figure 4A. Figure 4A clearly does not show the embodiment of the screen being “flushed” with the adjacent wall surface structure and, additionally provides evidence to the fact that screen of the display monitor can never form a continuous plane or unbroken surface with the adjacent wall surface structure, but can only form a surface that is offset therefrom or “substantially flushed”, in light of the Owner's instant disclosure.

In that light, Amano et al. clearly discloses “information signal devices **8a-8n**” being formed on the transitional portion of the sidewalls, as shown in Figures 4, 5 and 6. The “information signal devices **8a-8n**” would never be really flush with the sidewall, however, the “information signal devices **8a-8n**” would be “substantially flush”, or offset therefrom, in light of the instant Owner's disclosure. Therefore, Amano et al. clearly discloses “the screen of the monitor (being) substantially flushed with the adjacent wall surface structure of the car” given its broadest reasonable interpretation.

**Issue 3: Rejections under 35 U.S.C. 103(a) as being unpatentable over
Maekawa et al. in view of Amano et al**

With respect to Owners reply/argument that Maekawa et al. fails to teach or suggest “the screen of the monitor (is) substantially flushed with the adjacent wall surface structure of the car”, the examiner respectfully disagrees. Although the claims are interpreted in light of the specification, limitations from the specification are not read into the claims. See *In re Van Geuns*, 988 F.2d 1181, 26 USPQ2d 1057 (Fed. Cir. 1993).

In that regard, it is improper to import claim limitations from the specification. “Although claims of issued patents are interpreted in light of the specification, prosecution history, prior art and other claims, this is not the mode of claim interpretation to be applied during examination. During examination, the claims must be interpreted as broadly as their terms reasonably allow” (see MPEP § 2111). “Though understanding the claim language may be aided by explanations contained in the written description, it is important not to import into a claim limitations that are not part of the claim. For example, a particular embodiment appearing in the written description may not be read into a claim when the claim language is broader than the embodiment” (again see MPEP § 2111).

As asserted in the previous Office action

(T)he term “substantially” is often used in conjunction with another term to describe a particular characteristic of the claimed invention. It is a broad term. (See MPEP 2173.05).

Art Unit: 3992

The recitation to “flush” is modified by the term “substantially” which essentially broadens the recitation of “flush”. The term “flush” is examined as “forming a continuous plane or unbroken surface.”³ The limitation of “substantially flushed” recites the screen of the monitor not forming a continuous plane or unbroken surface, but to the screen not wholly forming a continuous plane or unbroken surface with the adjacent wall surface structure. Owner discloses

An alternative embodiment is illustrated in FIG. 4A, a view similar to that of FIG. 4. In this alternative embodiment, CRT video monitor 22 is replaced with an LCD-based video monitor 22A which is of thin, rectangular cross-section, and occupies less space in the ceiling structure of the car. Accordingly, it can be moved towards the ceiling so that its viewing screen is substantially flush with or even behind the light panel 40. This use of an LCD-based monitor gives a better aesthetic appearance to the inside of the subway car as a whole, as well as improving the display performance by minimizing the interference effects, as previously discussed. (Page 5, lines 35-46)

Included below is Figure 4A.

³ “flush.” Merriam-Webster Online Dictionary. 2012. Merriam-Webster Online. 10 April 2012 <<http://www.merriam-webster.com/dictionary/flush>>

Art Unit: 3992

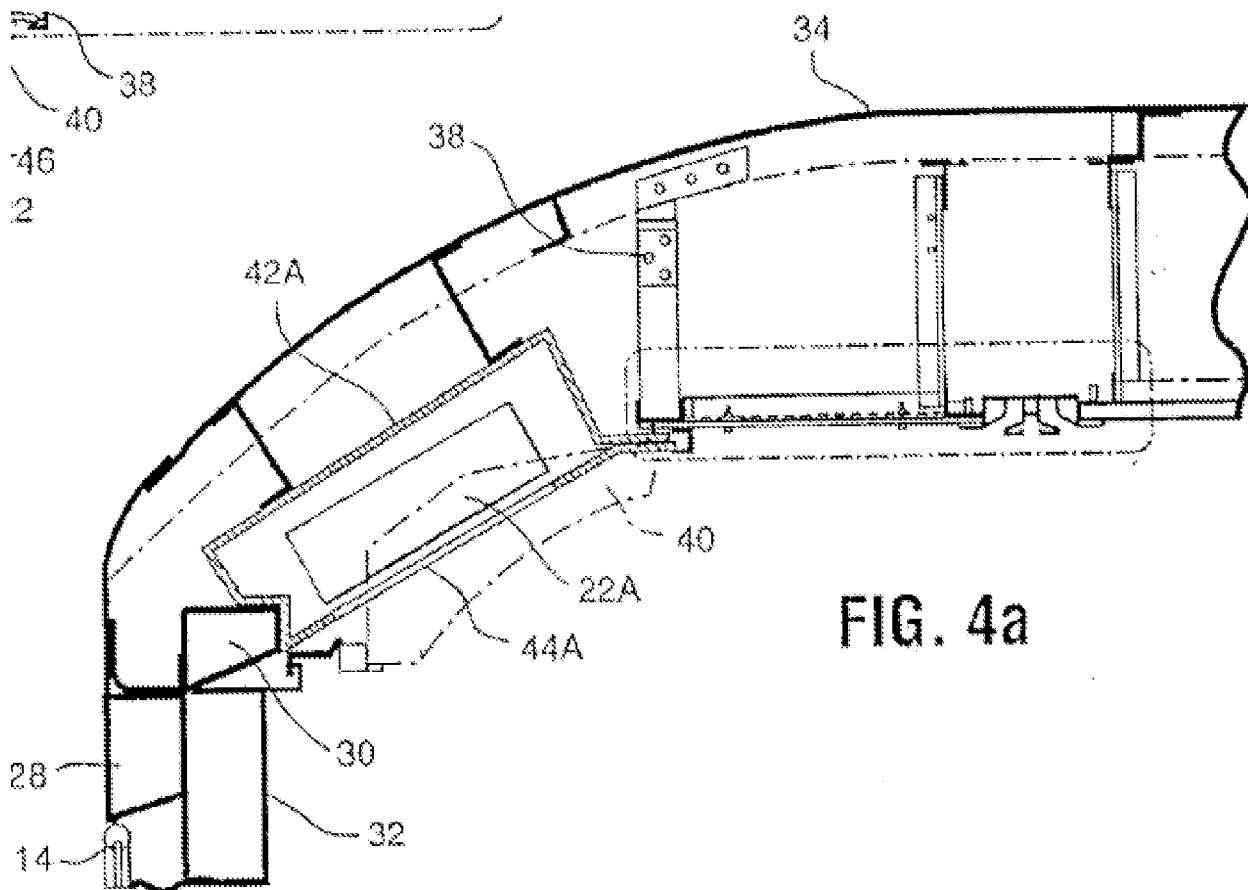

FIG. 4a

As asserted above, the

*“CRT video monitor is replaced with an LCD-based video monitor **22A** which is of thin, rectangular cross-section, and occupies less space in the ceiling structure of the car”.*

In Figure 4A, Owner explicitly discloses the monitor **22A** being behind the light panel **40** (see Figure 4A above). Owner alludes to the monitor **22A** being “substantially flush”, however, never provides explicit disclosure of the embodiment. Moreover, after further examination of Figure 4A, the actual viewing screen of the monitor **22A** can never really be flush with the light panel since the screen of the monitor **22A** is further behind the transport screen **44A** of the appropriately shaped enclosure **42A**, hence there is an

Art Unit: 3992

actual space and/or distance between the actual viewing screen of the monitor **22A** and the transport screen **44A** of the appropriately shaped enclosure **42A**. Furthermore, Owner never defines the term “flushed” and only alludes to the disclosure of “substantially flushed” in light of Figure 4A. Figure 4A clearly does not show the embodiment of the screen being “flushed” with the adjacent wall surface structure and, additionally provides evidence to the fact that screen of the display monitor can never form a continuous plane or unbroken surface with the adjacent wall surface structure, but can only form a surface that is offset therefrom or “substantially flushed”, in light of the Owner's instant disclosure.

In that light, Maekawa et al. clearly discloses the screen (**display**) of the plurality of monitor (**101-124**) being placed on the sidewall so that each video screen (**display**) is readily visible to passengers in the subway car, as is evidenced by Figure 2. In addition, Maekawa et al. discloses the plurality of monitor (**101-124**) being a “liquid crystal panel” having a low profile (page 738, bottom right portion). A “liquid crystal panel” would never be really flush with the sidewall, however, the “liquid crystal panel”, would be “substantially flush”, or offset therefrom, in light of the instant Owner's disclosure. Therefore, Maekawa et al. clearly discloses “the screen of the monitor (being) substantially flushed with the adjacent wall surface structure of the car” given its broadest reasonable interpretation.

Issue 5: Rejections under 35 U.S.C. 103(a) as being unpatentable over Minesaki in view of Moore et al.

With respect to Owners reply/argument that Minesaki fails to expressly or inherently describe “each of said monitor being mounted at the junction of the sidewall and ceiling”, the examiner respectfully disagrees. As Owner has noted, Minesaki discloses

This information transmission display part J may also be formed on the sidewall of the train car (page 590, right upper most column).

Minesaki further discloses such a configuration in the annotated Figure 2, as shown below

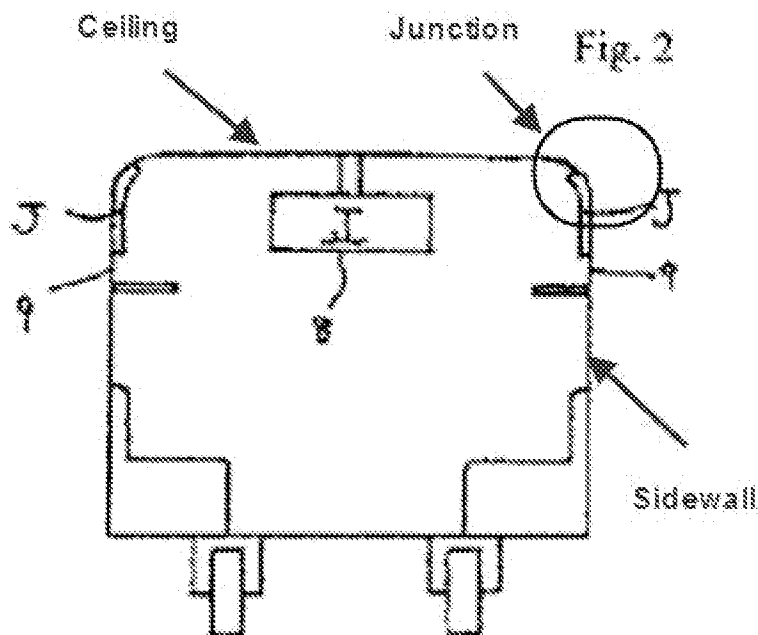

In the annotated Figure 2 above, Minesaki illustrates a ceiling portion, a sidewall portion, and a junction portion between the respective sidewall and ceiling portions (see

Art Unit: 3992

above). In addition, the monitor (information transmission display part J) is clearly partially mounted and disposed in the junction portion between the respective sidewall and ceiling portions. Therefore, Minesaki fully meets each of said monitor being mounted at the junction of the sidewall and ceiling “each of said monitor being mounted at the junction of the sidewall and ceiling” given its broadest reasonable interpretation.

With respect to Owners reply/argument that Minesaki fails to expressly or inherently describe “the screen of the monitor... (is) directed obliquely downward toward the car seats”, the examiner respectfully disagrees. The Owner further argues that the recitation to “the screen of the monitor...(is) directed obliquely downward toward the car seats” does not include prior art in which “only portions of the screen of the monitor are directed obliquely downwardly”. It is noted that the features upon which applicant relies (i.e. the total screen of the monitor being directed obliquely downward toward the car seats) are not recited in the rejected claim(s). Although the claims are interpreted in light of the specification, limitations from the specification are not read into the claims. See *In re Van Geuns*, 988 F.2d 1181, 26 USPQ2d 1057 (Fed. Cir. 1993).

In that regard, it is improper to import claim limitations from the specification. “Although claims of issued patents are interpreted in light of the specification, prosecution history, prior art and other claims, this is not the mode of claim interpretation to be applied during examination. During examination, the claims must be interpreted as broadly as their terms reasonably allow” (see MPEP § 2111). “Though understanding the claim language may be aided by explanations contained in the written description, it is important not to import into a claim limitations that are not part of

Art Unit: 3992

the claim. For example, a particular embodiment appearing in the written description may not be read into a claim when the claim language is broader than the embodiment” (again see MPEP § 2111).

It is asserted by the examiner that Owner has conceded that

“Patent Owner admits that the information transmission display parts J of Minesaki appear curved with the top portion seemingly directed obliquely downwardly...” (page 8, lines 18-19).

Minesaki clearly discloses portion of the screen of the monitor **J** being directed obliquely downward toward the car seats, as is evidenced by Figure 2. Therefore, since portions of the monitor screen of Minesaki are directed obliquely downward toward the car seats, Minesaki fully meets “the screen of the monitor...(is) directed obliquely downward toward the car seats” given its broadest reasonable interpretation.

Issue 6: Rejections under 35 U.S.C. 103(a) as being unpatentable over Amano et al. in view of Moore et al.

With respect to Owner’s reply/argument that Amano et al. teaches away from “the screen monitor (being) substantially flushed with the adjacent wall surface structure of the car”, the examiner respectfully disagrees. While Amano et al. teaches a preferred embodiment of the screen of the monitor protruding a certain distance from the transitional portion of the sidewall (see Figures 4-6), disclosed examples and preferred embodiments do not constitute a teaching away from a broader disclosure or non-preferred embodiments. Furthermore, the examiner can find no teaching to criticize, discredit or otherwise discourage trying to make the screen of monitor substantially

Art Unit: 3992

flush with the adjacent wall surface structure of the car (see MPEP § 2123). Therefore, the examiner asserts that Amano et al. does not teach away from using a screen monitor that is substantially flushed with the adjacent wall surface structure of Moore et al. given its broadest reasonable interpretation.

Furthermore, in response to Owner's reply/ argument that the modifications to the area near the junction of the sidewall and ceiling of the Amano et al. train would render the Amano et al. train unsatisfactory for its intended purpose because the storage area would have to be eliminated entirely or substantially reduced, the test for obviousness is not whether the features of a secondary reference may be bodily incorporated into the structure of the primary reference; nor is it that the claimed invention must be expressly suggested in any one or all of the references. Rather, the test is what the combined teachings of the references would have suggested to those of ordinary skill in the art. See *In re Keller*, 642 F.2d 413, 208 USPQ 871 (CCPA 1981).

In that light, the storage devices of Amano et al. are permanent structures of the train, as is evidenced by Figures 4-6. Specifically, the storage area structures in Figures 5 and 6 are independent of the information signal display devices **8**. Similarly, the storage device in Figure 4 seems to have a slotted area in which one of ordinary skill in the art would render the information signal display devices **8** as also being independent from the storage device. Clearly, the modification of the information signal display devices **8** of Amano et al. to be "substantially flushed", as taught by Moore et al., would not destroy the functionality of the storage devices of Amano et al, but instead, provide even more potential area for storage. Therefore, the examiner asserts that the

Art Unit: 3992

replacement of the slightly protruding information signal display devices **8** of Amano et al. with the “substantially flushed” monitors of Moore et al. would not render Amano et al. unsatisfactory for its intended purpose because Amano et al. would still provide real-time information to the users of the train via the monitors as well as potentially even more adequate storage for particular items.

Issues 7 and 8: Rejections under 35 U.S.C. 103(a) as being unpatentable over Maekawa et al. and/or Shinagawa et al., either in view of Amano et al. and Moore et al.

Furthermore, in response to Owner’s reply/ argument that the modifications to the area near the junction of the sidewall and ceiling of the Amano et al. train would render the Amano et al. train unsatisfactory for its intended purpose because the storage area would have to be eliminated entirely or substantially reduced, the test for obviousness is not whether the features of a secondary reference may be bodily incorporated into the structure of the primary reference; nor is it that the claimed invention must be expressly suggested in any one or all of the references. Rather, the test is what the combined teachings of the references would have suggested to those of ordinary skill in the art. See *In re Keller*, 642 F.2d 413, 208 USPQ 871 (CCPA 1981).

In that light, the storage devices of Amano et al. are permanent structures of the train, as is evidenced by Figures 4-6. Specifically, the storage area structures in Figures 5 and 6 are independent of the information signal display devices **8**. Similarly, the storage device in Figure 4 seems to have a slotted area in which one of ordinary skill in

Art Unit: 3992

the art would render the information signal display devices **8** as also being independent from the storage device. Clearly, the modification of the information signal display devices **8** of Amano et al. to be “substantially flushed”, as taught by Moore et al., would not destroy the functionality of the storage devices of Amano et al, but instead, provide even more potential area for storage. Therefore, the examiner asserts that the replacement of the slightly protruding information signal display devices **8** of Amano et al. with the “substantially flushed” monitors of Moore et al. would not render Amano et al. unsatisfactory for its intended purpose because Amano et al. would still provide real-time information to the users of the train via the monitors as well as potentially even more adequate storage for particular items.

STATEMENT OF REASONS FOR PATENTABILITY AND/OR CONFIRMATION

The following is an examiner's statement of reasons for patentability and/or confirmation of the claims found patentable in this reexamination proceeding: The prior art of record clearly teaches a subway car for mass transportation having a video display system with each of a plurality of monitors being located substantially flush in a transitional wall portion between the ceiling and side wall of the subway car (see *Minesaki, Amano et al., Maekawa et al., and Shinagawa et al.* alone, or in various combinations). In addition, the prior art of record of Moore et al. teaches a monitor of a video display system being either flushed or substantially flushed with the surrounding wall surfaces (see Moore et al.; column 7, lines 32-51). However, with respect to the limitation of independent claims 8 and 21, the prior art of record does not teach a

Art Unit: 3992

plurality of transparent cover units that cover the video display monitors in which each of the transparent cover units being either flush or substantially flushed with the adjacent transitional wall portion. Furthermore, with respect to the limitation of independent claim 15, the prior art of record does not teach a back lit panel disposed on the transitional segment disposed adjacent the ceiling and a respective wall.

Therefore, allowance of claims 8-14 and 21-30 are indicated because none of the prior art of record teaches or fairly suggests a subway car for mass transportation having a video display system, with all of the limitations of independent claims 8 and 21, particularly at least the limitations of providing a plurality of transparent cover units that cover the video display monitors in which each of the transparent cover units being either flush or substantially flushed with the adjacent transitional wall portion in combination with the apparatus limitations as set forth in the claims. Claims 9-14 and 22-30 are allowable at least because they depend from an allowable independent claim.

Similarly, allowance of claims 15-18 and 20 are indicated because none of the prior art of record teaches or fairly suggests a subway car for mass transportation having a video display system, with all of the limitations of independent claim 15, particularly at least the limitations of providing a back lit panel disposed on the transitional segment disposed adjacent the ceiling and a respective wall in combination with the apparatus limitations as set forth in the claims. Claims 16-18 and 20 are allowable at least because they depend from an allowable independent claim.

Any comments considered necessary by PATENT OWNER regarding the above statement must be submitted promptly to avoid processing delays. Such submission by

Art Unit: 3992

the patent owner should be labeled: "Comments on Statement of Reasons for Patentability and/or Confirmation" and will be placed in the reexamination file.

Conclusion

Extensions of time under 37 CFR 1.136(a) will not be permitted in these proceedings because the provisions of 37 CFR 1.136 apply only to "an applicant" and not to parties in a reexamination proceeding. Additionally, 35 U.S.C. 305 requires that reexamination proceedings "will be conducted with special dispatch" (37 CFR 1.550(a)). Extension of time in *ex parte* reexamination proceedings are provided for in 37 CFR 1.550(c).

The patent owner is reminded of the continuing responsibility under 37 CFR 1.565(a), to apprise the Office of any litigation activity, or other prior or concurrent proceeding, involving Patent No. 6,700,602 throughout the course of this reexamination proceeding. See MPEP §§ 2207, 2282 and 2286.

All correspondence relating to this *ex parte* reexamination proceeding should be directed:

By Mail to: Mail Stop *Ex Parte* Reexam
 Central Reexamination Unit
 Commissioner for Patents
 United States Patent & Trademark Office
 P.O. Box 1450
 Alexandria, VA 22313-1450

By FAX to: (571) 273-9900
 Central Reexamination Unit

By hand: Customer Service Window
 Randolph Building
 401 Dulany Street
 Alexandria, VA 22314

By EFS-Web:

Art Unit: 3992

Registered users of EFS-Web may alternatively submit such correspondence via the electronic filing system EFS-Web, at

<https://efs.uspto.gov/efile/myportal/efs-registered>

EFS-Web offers the benefit of quick submission to the particular area of the Office that needs to act on the correspondence. Also, EFS-Web submissions are "soft scanned" (i.e., electronically uploaded) directly into the official file for the reexamination proceeding, which offers parties the opportunity to review the content of their submissions after the "soft scanning" process is complete.

Any inquiry concerning this communication or earlier communications from the Reexamination Legal Advisor or Examiner, or as to the status of this proceeding, should be directed to the Central Reexamination Unit at telephone number (571) 272-7705.

/Stephen J Ralis/
Primary Examiner, Art Unit 3992

Conferee

/Luke S. Wassum/
Primary Examiner, Art Unit 3992

Conferee

/Sudhanshu C Pathak/
Supervisory Patent Examiner, Art
Unit 3992

SJR
1/04/2013

Application/Control Number: 90/011,861
Art Unit: 3992

Page 27

BLAIR.001A

OK TO ENTER: /S.R./

PATENT

IN THE UNITED STATES PATENT AND TRADEMARK OFFICE

Patentee : Scott Blair)
 Patent No. : 6,700,602 – Issued 03/02/04)
 Control No. : 90/011,861)
 Filed : August 16, 2011)
 For : **SUBWAY TV MEDIA SYSTEM**)
 Examiner : Stephen Ralis)
 Group Art Unit: 3992)



27299

PATENT TRADEMARK OFFICE

CERTIFICATE OF ELECTRONIC (EFS-WEB) TRANSMISSION

I hereby certify that this correspondence is being transmitted via the Office electronic filing system in accordance with 37 C.F.R. § 1.8(a)(1)(C) from the Pacific Time Zone of the United States on the local date shown below.

Dated: June 25, 2012

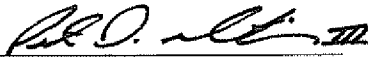
By: 
Peter J. Gutierrez, III, Reg. No. 56,732

5

RESPONSE TO FINAL OFFICE ACTION – EX PARTE REEXAMINATION

10 Mail Stop *Ex Parte* Reexam
 Central Reexamination Unit
 Commissioner for Patents
 United States Patent & Trademark Office
 P.O. Box 1450
 15 Alexandria, VA 22313-1450

Dear Sir:

In response to the Final Office Action in *Ex Parte* Reexamination dated April 25, 2012 (“*Ex Parte* Office Action”), the following is provided:

20

Reexamination 	Application/Control No. 90011861	Applicant(s)/Patent Under Reexamination 6700602
	Certificate Date	Certificate Number

Requester Correspondence Address:	<input checked="" type="checkbox"/> Patent Owner	<input type="checkbox"/> Third Party
GAZDZINSKI & ASSOCIATES, PC 16644 WEST BERNARDO DRIVE SUITE 201 SAN DIEGO, CA 92127		

LITIGATION REVIEW <input checked="" type="checkbox"/>	SR (examiner initials)	09/27/2011 (date)
Case Name	Director Initials	
No Litigation is currently pending.		

COPENDING OFFICE PROCEEDINGS	
TYPE OF PROCEEDING	NUMBER
1. No copending proceedings.-	

--	--

Ex Parte Reexamination Advisory Action Before the Filing of an Appeal Brief	Control No. 90/011,861	Patent Under Reexamination 6700602
	Examiner STEPHEN RALIS	Art Unit 3992

--The MAILING DATE of this communication appears on the cover sheet with the correspondence address--

THE PROPOSED RESPONSE FILED 25 June 2012 FAILS TO OVERCOME ALL OF THE REJECTIONS IN THE FINAL REJECTION MAILED 25 April 2012.

1. Unless a timely appeal is filed, or other appropriate action by the patent owner is taken to overcome all of the outstanding rejection(s), this prosecution of the present *ex parte* reexamination proceeding WILL BE TERMINATED and a Notice of Intent to Issue *Ex Parte* Reexamination Certificate will be mailed in due course. Any finally rejected claims, or claims objected to, will be CANCELLED.

THE PERIOD FOR RESPONSE IS EXTENDED TO RUN 6 MONTHS FROM THE MAILING DATE OF THE FINAL REJECTION. Extensions of time are governed by 37 CFR 1.550(c).

NOTICE OF APPEAL

2. An Appeal Brief is due two months from the date of the Notice of Appeal filed on _____ to avoid dismissal of the appeal. See 37 CFR 41.37(a). Extensions of time are governed by 37 CFR 1.550(c). See 37 CFR 41.37(e).

AMENDMENTS

3. The proposed amendment(s) filed after a final action, but prior to the date of filing a brief, will not be entered because:
- (a) They raise new issues that would require further consideration and/or search (see NOTE below);
 - (b) They raise the issue of new matter (see NOTE below);
 - (c) They are not deemed to place the proceeding in better form for appeal by materially reducing or simplifying the issues for appeal; and/or
 - (d) They present additional claims without canceling a corresponding number of finally rejected claims.

NOTE: _____ (See 37 CFR 1.116 and 41.33(a)).

4. Patent owner's proposed response filed 25 June 2012 has overcome the following rejection(s): see attached
5. The proposed new or amended claim(s) _____ would be allowable if submitted in a separate, timely filed amendment canceling the non-allowable claim(s).

6. For purposes of appeal, the proposed amendment(s) a) will not be entered, or b) will be entered and an explanation of how the new or amended claim(s) would be rejected is provided below or appended.

The status of the claim(s) is (or will be) as follows:

Claim(s) patentable and/or confirmed: 8-18 and 20-30

Claim(s) objected to: _____

Claim(s) rejected: 1

Claim(s) not subject to reexamination: 2-7

AFFIDAVIT OR OTHER EVIDENCE

7. The affidavit or other evidence filed after a final action, but before or on the date of filing a Notice of Appeal will not be entered because patent owner failed to provide a showing of good and sufficient reasons why the affidavit or other evidence is necessary and was not earlier presented. See 37 CFR 1.116(e).
8. The affidavit or other evidence filed after the date of filing a Notice of Appeal, but prior to the date of filing a brief, will not be entered because the affidavit or other evidence fails to overcome all rejections under appeal and/or appellant failed to provide a showing of good and sufficient reasons why the affidavit or other evidence is necessary and was not earlier presented. See 37 CFR 41.33(d)(1).
9. The affidavit or other evidence is entered. An explanation of the status of the claims after entry is below or attached.

REQUEST FOR RECONSIDERATION/OTHER

10. The request for reconsideration has been considered but does NOT place the application in condition for allowance because: see attached.
11. Note the attached Information Disclosure Statement(s), PTO/SB/08, Paper No(s) _____.
12. Other: _____.

/Stephen J Ralis/ Primary Examiner, Art Unit 3992		
cc: Requester (if third party requester)		

IN THE UNITED STATES PATENT AND TRADEMARK OFFICE

Patentee : Scott Blair)
 Patent No. : 6,700,602 – Issued 03/02/2004)
 Control No. : 90/011,861)
 Filed : August 16, 2011)
 For : **SUBWAY TV MEDIA SYSTEM**)
 Examiner : Stephen Ralis)
 Group Art Unit: 3992)



27299

PATENT TRADEMARK OFFICE

CERTIFICATE OF ELECTRONIC (EFS-WEB) TRANSMISSION

I hereby certify that this correspondence is being transmitted via the Office electronic filing system in accordance with 37 C.F.R. § 1.8(a)(i)(C) from the Pacific Time Zone of the United States on the local date shown below.

January 18, 2013

(Date)

Peter J. Gutierrez III

Peter J. Gutierrez III, Reg. No. 56,732

PETITION FOR REVIVAL OF AN APPLICATION FOR EX PARTE REEXAMINATION UNDER 37 C.F.R. § 1.137(b)

Mail Stop *Ex Parte Reexam*
Central Reexamination Unit
Commissioner For Patents
P.O. Box 1450
Alexandria, VA 22313-1450

Dear Sir:

The above-identified application for ex parte reexamination became abandoned for failure to file a timely and proper reply to a Final Office Action from the United States Patent and Trademark Office dated April 25, 2012. The Patent Office issued an Advisory Action dated January 16, 2013, terminating the aforementioned ex parte reexamination.

Applicant respectfully submits that pursuant to MPEP §711.03(c) citing *H.R. Rep. No. 542, 97th Cong., 2d Sess. 6-7 (1982)* that the abandonment of the application was not the result of a deliberately chosen course of action on the part of the Assignee. The following outlines the evidence applicable to this matter:

Control No. : 90/011,861
Filed : August 16, 2011

1. On April 25, 2012, Examiner Stephen Ralis of the USPTO issued a Final Office Action dated April 25, 2012 to Gazdzinski & Associates, PC ("GAPC"), Attorneys for Patentee Scott Blair.

2. On June 25, 2012, GAPC timely filed a Response to the Final Office Action dated April 25, 2012.

3. On January 16, 2013, an Advisory Action was issued to GAPC with respect to the above ex parte reexamination. The Advisory Action was issued well after the six month time period set forth in the Final Office Action, and thus terminated the aforementioned ex parte reexamination.

4. Applicant submits that the entire delay in filing the Notice of Appeal to the April 25, 2012 Final Office Action from the due date for this Notice of Appeal (i.e. October 25, 2012) until the filing of a grantable petition pursuant to 37 C.F.R. §1.137 was unintentional.

Applicant hereby petitions for revival of this application under 37 C.F.R. §1.137(b).

The petition fee for revival of an unintentionally abandoned application for a small entity is \$945.00 in accordance with 37 C.F.R. § 1.17(m). The Commissioner is hereby authorized to charge the petition fee amount to Deposit Account No. 501423.

I hereby declare that all statements made herein of my own knowledge are true and that all statements made on information and belief are believed to be true; and further that these statements were made with the knowledge that willful false statements and the like so made are punishable by fine or imprisonment, or both, under Section 1001 of Title 18 of the United States Code and that such willful, false statements may jeopardize the validity of the application or any patent issued thereon.

Respectfully submitted,

GAZDZINSKI & ASSOCIATES, PC

Dated: January 18, 2013

By: 

Peter J. Gutierrez, III
Reg. No. 56,732
16644 West Bernardo Drive, Suite 201
San Diego, CA 92127
Telephone No.: (858) 675-1670
Facsimile No.: (858) 675-1674

Under the Paperwork Reduction Act of 1995, no persons are required to respond to a collection of information unless it displays a valid OMB control number.

NOTICE OF APPEAL FROM THE EXAMINER TO THE PATENT TRIAL AND APPEAL BOARD	Docket Number (Optional) BLAIR.001A
---	---

I hereby certify that this correspondence is being facsimile transmitted to the USPTO, EFS-Web transmitted to the USPTO, or deposited with the United States Postal Service with sufficient postage in an envelope addressed to "Commissioner for Patents, P.O. Box 1450, Alexandria, Alexandria, VA 22313-1450" [37 CFR 1.8(a)] on _____ Signature _____ Typed or printed name _____	in re Application of Scott Blair	
	Application Number 90/011,861	Filed August 16, 2011
	For SUBWAY TV MEDIA SYSTEM	
	Art Unit 3992	Examiner Stephen Ralis

Applicant hereby **appeals** to the Patent Trial and Appeal Board from the last decision of the examiner.

The fee for this Notice of Appeal is (37 CFR 41.20(b)(1)) \$ 315

Applicant claims small entity status. See 37 CFR 1.27. Therefore, the fee shown above is reduced by half, and the resulting fee is: \$ _____
 A check in the amount of the fee is enclosed.
 Payment by credit card. Form PTO-2038 is attached.
 The Director has already been authorized to charge fees in this application to a Deposit Account.
 The Director is hereby authorized to charge any fees which may be required, or credit any overpayment to Deposit Account No. 501423.
 Payment made via EFS-Web.
 A petition for an extension of time under 37 CFR 1.136(a) (PTO/SB/22 or equivalent) is enclosed.

WARNING: Information on this form may become public. Credit card information should not be included on this form. Provide credit card information and authorization on PTO-2038.

I am the

applicant.
 attorney or agent of record.
 Registration number 56,732
 attorney or agent acting under 37 CFR 1.34
 Registration number if acting under 37 CFR 1.34 _____

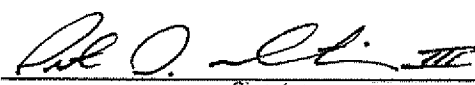

 Signature
Peter J. Gutierrez, III

 Typed or printed name
(858) 675-1670

 Telephone number
January 18, 2013

 Date

NOTE: This form must be signed in accordance with 37 CFR 1.33. See 37 CFR 1.4 for signature requirements and certifications. Submit multiple forms if more than one signature is required, see below*.

*Total of _____ forms are submitted.

This collection of information is required by 37 CFR 41.31. The information is required to obtain or retain a benefit by the public which is to file (and by the USPTO to process) an application. Confidentiality is governed by 35 U.S.C. 122 and 37 CFR 1.11, 1.14 and 41.6. This collection is estimated to take 12 minutes to complete, including gathering, preparing, and submitting the completed application form to the USPTO. Time will vary depending upon the individual case. Any comments on the amount of time you require to complete this form and/or suggestions for reducing this burden, should be sent to the Chief Information Officer, U.S. Patent and Trademark Office, U.S. Department of Commerce, P.O. Box 1450, Alexandria, VA 22313-1450. DO NOT SEND FEES OR COMPLETED FORMS TO THIS ADDRESS. SEND TO: Commissioner for Patents, P.O. Box 1450, Alexandria, VA 22313-1450.

If you need assistance in completing the form, call 1-800-PTO-9199 and select option 2.

Electronic Patent Application Fee Transmittal

Application Number:	90011861			
Filing Date:	16-Aug-2011			
Title of Invention:	SUBWAY TV MEDIA SYSTEM			
First Named Inventor/Applicant Name:	6700602			
Filer:	Peter John Gutierrez III			
Attorney Docket Number:	BLAIR.001A			
Filed as Small Entity				
ex parte reexam Filing Fees				
Description	Fee Code	Quantity	Amount	Sub-Total in USD(\$)
Basic Filing:				
Pages:				
Claims:				
Miscellaneous-Filing:				
Petition:				
Petition-revive unintent. abandoned appl	2453	1	945	945
Patent-Appeals-and-Interference:				
Notice of appeal	2401	1	315	315
Post-Allowance-and-Post-Issuance:				

Description	Fee Code	Quantity	Amount	Sub-Total in USD(\$)
Extension-of-Time:				
Miscellaneous:				
Total in USD (\$)				1260

Electronic Acknowledgement Receipt

EFS ID:	14743428
Application Number:	90011861
International Application Number:	
Confirmation Number:	3736
Title of Invention:	SUBWAY TV MEDIA SYSTEM
First Named Inventor/Applicant Name:	6700602
Customer Number:	27299
Filer:	Peter John Gutierrez III
Filer Authorized By:	
Attorney Docket Number:	BLAIR.001A
Receipt Date:	18-JAN-2013
Filing Date:	16-AUG-2011
Time Stamp:	17:52:26
Application Type:	Reexam (Patent Owner)

Payment information:

Submitted with Payment	yes
Payment Type	Deposit Account
Payment was successfully received in RAM	\$1260
RAM confirmation Number	5518
Deposit Account	501423
Authorized User	

The Director of the USPTO is hereby authorized to charge indicated fees and credit any overpayment as follows:

Charge any Additional Fees required under 37 C.F.R. Section 1.16 (National application filing, search, and examination fees)

Charge any Additional Fees required under 37 C.F.R. Section 1.17 (Patent application and reexamination processing fees)

Charge any Additional Fees required under 37 C.F.R. Section 1.19 (Document supply fees)

Charge any Additional Fees required under 37 C.F.R. Section 1.20 (Post Issuance fees)

Charge any Additional Fees required under 37 C.F.R. Section 1.21 (Miscellaneous fees and charges)

File Listing:

Document Number	Document Description	File Name	File Size(Bytes)/ Message Digest	Multi Part /.zip	Pages (if appl.)
1	Petition for review by the Office of Petitions.	Petition.pdf	76650 853593e9882d2a356920a04c724c52da854380fd	no	2

Warnings:

Information:

2	Notice of Appeal Filed	NTC_of_Appeal.pdf	53964 8b6b42fa00468e01a7b271c51e1863e61f289ab6	no	1
---	------------------------	-------------------	---	----	---

Warnings:

Information:

3	Fee Worksheet (SB06)	fee-info.pdf	32014 9e541d0c6e4bea50a8f9340fe3c9098f47f66a00	no	2
---	----------------------	--------------	---	----	---

Warnings:

Information:

Total Files Size (in bytes):

162628

This Acknowledgement Receipt evidences receipt on the noted date by the USPTO of the indicated documents, characterized by the applicant, and including page counts, where applicable. It serves as evidence of receipt similar to a Post Card, as described in MPEP 503.

New Applications Under 35 U.S.C. 111

If a new application is being filed and the application includes the necessary components for a filing date (see 37 CFR 1.53(b)-(d) and MPEP 506), a Filing Receipt (37 CFR 1.54) will be issued in due course and the date shown on this Acknowledgement Receipt will establish the filing date of the application.

National Stage of an International Application under 35 U.S.C. 371

If a timely submission to enter the national stage of an international application is compliant with the conditions of 35 U.S.C. 371 and other applicable requirements a Form PCT/DO/EO/903 indicating acceptance of the application as a national stage submission under 35 U.S.C. 371 will be issued in addition to the Filing Receipt, in due course.

New International Application Filed with the USPTO as a Receiving Office

If a new international application is being filed and the international application includes the necessary components for an international filing date (see PCT Article 11 and MPEP 1810), a Notification of the International Application Number and of the International Filing Date (Form PCT/RO/105) will be issued in due course, subject to prescriptions concerning national security, and the date shown on this Acknowledgement Receipt will establish the international filing date of the application.

IN THE UNITED STATES PATENT AND TRADEMARK OFFICE

5 Patent Owner: Scott Blair Control No.: 90/011,861
Examiner: Stephen J. Ralis Gr. Art Unit: 3992
Filing Date: August 16, 2011
For: **SUBWAY TV MEDIA SYSTEM**

10 APPEAL BRIEF PURSUANT TO 37 CFR 41.37

Dear Sir or Madam:

15 In response to the Final Office Action in *Ex Parte* Reexamination dated April 25, 2012 (“Final *Ex Parte* Office Action”) and the Advisory Action in *Ex Parte* Reexamination dated January 16, 2013 (“*Ex Parte* Advisory Action”), Patent Owner herein files an appeal brief for the above-identified application.

Real Party in Interest

20 Scott Blair (the Patent Owner for Reexamination Control No. 90/011,861) is the real party in interest.

Related Appeals and Interferences

25 Not Applicable.

Status of Claims

30 Claims 1 – 18 and 20 – 30 are now pending in the application.

Per the *Ex Parte* Advisory Action, Claim 1 stands rejected, Claims 2 – 7 are not subject to reexamination and Claims 8 – 18 and 20 – 30 are patentable and/or confirmed.

35 Patent Owner herein explicitly appeals the rejection of Claim 1.

Status of Amendments

40 Patent Owner has not submitted amendments to any of the claims subsequent to the *Ex Parte* Advisory Action (see also the response to the Final *Ex Parte* Office Action dated June 25, 2012).

Summary of Claimed Subject Matter

45 **Claim 1** – Claim 1 discloses a subway car for mass transportation including longitudinal opposed sidewalls disclosed at, *inter alia*, FIGS. 1A and 1B, as well as at FIG. 2, along with its accompanying disclosure of Patent Owner’s specification. The subway car includes a ceiling adjoining the sidewalls disclosed at, *inter alia*, FIG. 4a, along with its accompanying disclosure

Control No. : 90/011,861
Filed : August 16, 2011

at Col. 5, lines 35 – 49 of Patent Owner’s specification. The subway car also includes a video display system comprising a plurality of video display monitors each having a video screen disclosed at, *inter alia*, Col. 5, lines 35 – 49 and Col. 5, lines 4 – 7 of Patent Owner’s specification. The subway car further includes a video signal source unit operatively connected to the monitors disclosed at; *inter alia*, Col. 5, lines 4 – 7 of Patent Owner’s specification. The monitors are spaced along the length of the car on opposed sides thereof disclosed at, *inter alia*, Col. 1, lines 45 – 50 as well as at Col. 4, lines 57 – 59 of Patent Owner’s specification. Each of the monitors are mounted at the junction of the sidewall and ceiling disclosed at, *inter alia*, Col. 3, line 67 – Col. 4, line 6 and Col. 4, lines 64 – 67 of Patent Owner’s specification. The screen of the monitor is substantially flushed with the adjacent wall surface structure of the car disclosed at; *inter alia*, Col. 5, lines 40 – 42 of Patent Owner’s specification. The screen of the monitor is further directed obliquely downwardly toward the car seats, so that each video screen is readily visible to passengers in the subway car disclosed at, *inter alia*, Col. 4, line 67 – Col. 5, line 4 of Patent Owner’s specification.

Grounds of Rejection to be Reviewed

1. Whether Claim 1 is unpatentable under 35 U.S.C. §102(b) as being anticipated by Minesaki (Japanese Publication No. JP 63-125984 of Japanese Application No. JP 61-272668, hereinafter “Minesaki”).
2. Whether Claim 1 is unpatentable under 35 U.S.C. §102(b) as being anticipated by Amano et al. (Japanese Publication No. JP 02-23985A, hereinafter “Amano”).
3. Whether Claim 1 is unpatentable under 35 U.S.C. §103(a) as being unpatentable over Maekawa et al. (Japanese Publication No. JP 04-160991A, hereinafter “Maekawa”) in view of Amano.
4. Whether Claim 1 is unpatentable under 35 U.S.C. §103(a) as being unpatentable over Minesaki in view of Moore et al. (U.S. Patent No. 3,480,727, hereinafter “Moore”).
5. Whether Claim 1 is unpatentable under 35 U.S.C. §103(a) as being unpatentable over Amano in view of Moore.
6. Whether Claim 1 is unpatentable under 35 U.S.C. §103(a) as being unpatentable over Maekawa and/or Shinagawa et al. (Japanese Publication No. JP 04-160991A, hereinafter “Shinagawa”), either in view of Amano and Moore.

Arguments

I. Rejection of Claim 1 Under 35 U.S.C. § 102 as Being Anticipated by Minesaki

Claim 1 – Patent Owner respectfully submits that it is well established that “[a] claim is anticipated only if each and every element as set forth in the claim is found, either expressly or

Control No. : 90/011,861
Filed : August 16, 2011

inherently described, in a single prior art reference." Verdegaal Bros. v. Union Oil Co. of California, 814 F.2d 628, 631, 2 USPQ2d 1051, 1053 (Fed. Cir. 1987). See also MPEP §2131.

5 With regards to the Office's rejection of Claim 1 as being anticipated by Minesaki, Patent Owner respectfully traverses. Specifically, Minesaki fails to expressly or inherently describe: (1) "each of said monitor being mounted at the junction of the sidewall and ceiling"; (2) "with the screen of the monitor substantially flushed with the adjacent wall surface structure of the car"; and (3) "directed obliquely downwardly toward the car seats".

10 With regards to the claimed feature "each of said monitor being mounted at the junction of the sidewall and ceiling", Minesaki appears to only contemplate two configurations for mounting the information transmission display (part J). Specifically, one such configuration contemplated by Minesaki is an "information display part J ... which is suspended and hangs down from the ceiling". {emphasis added} Such a configuration as described does not expressly or inherently
15 describe mounting the monitor at the junction of the sidewall and ceiling.

Minesaki's second configuration contemplates that the "information transmission display part J may also be formed on the sidewall 9 of the train car." {emphasis added} Accordingly, Minesaki only appears to contemplate suspending the information transmission display part from
20 the ceiling, or alternatively, forming the information transmission display part on the sidewall of the train car, and respectfully does *not* expressly contemplate mounting the monitor at the junction of the sidewall and ceiling. Furthermore, The Office alleges at page 100 of the Final *Ex Parte* Office Action that Fig. 2 of Minesaki illustrates the information transmission display part J at the junction of the sidewall and the ceiling.

25 Furthermore, Patent Owner respectfully submits that it is clear that the drawing of Fig. 2 is not intended to be to scale, and that the drafting quality of Fig. 2 is poor. Patent Owner notes that per MPEP §2125:

30 "When the reference does not disclose that the drawings are to scale and is silent as to dimensions, arguments based on measurement of the drawing features are of little value. See Hockerson-Halberstadt, Inc. v. Avia Group Int'l, 222 F.3d 951, 956, 55 USPQ2d 1487, 1491 (Fed. Cir. 2000)"

35 For example, and as illustrated in Fig. 2, the information transmission display parts J are shown as being curved along the top portion of the display. However, Minesaki provides no mention or explanation for this curvature in its specification, and it would appear that such a curved feature is quite unusual in that it seemingly affects only the very top portion of the display shown in FIG. 2, which optically would seem to distort the light rays emanating from the display in an inconsistent
40 manner (and hence distort at least a portion of any image displayed thereon, akin to a prism). Accordingly, it is believed that this drawing (Fig. 2) is at best unreliable (and at worst, inconsistent) in its teachings when considered without the context of the two configurations discussed *supra* provided by the written detailed description, and would not expressly or inherently describe a monitor being "mounted at the junction of the sidewall and ceiling" to one of ordinary skill in the
45 art.

Furthermore, with regards to the claimed feature “with the screen of the monitor substantially flushed with the adjacent wall surface structure of the car”, the Office alleges that the term “substantially” is often used in conjunction with another term to describe a particular characteristic of the claimed invention, and is further construed to be a broad term (citing MPEP §2173.05). While Patent Owner agrees that the term “substantially” is construed broadly, the use of the term “substantially” cannot be construed so broadly as to read the term “flushed” completely out of the claim. See e.g., *Exxon Chem. Patents v. Lubrizol Corp.*, 64 F.3d 1553, 1555 (Fed. Cir. 1995), *cert. denied*, 518 U.S. 1020 (1996), as it believes the Office’s interpretation has done.

Furthermore, Patent Owner notes that terms in its claims must be interpreted in light of Patent Owner’s specification as filed; see MPEP § 2111; “During patent examination, the pending claims must be “given their broadest reasonable interpretation consistent with the specification.” *Phillips v. AWH Corp.*, 415 F.3d 1303, 75 USPQ2d 1321 (Fed. Cir. 2005)” {emphasis added}. Fig. 2 of Minesaki is reproduced below for the convenience of the Office.

Fig. 2

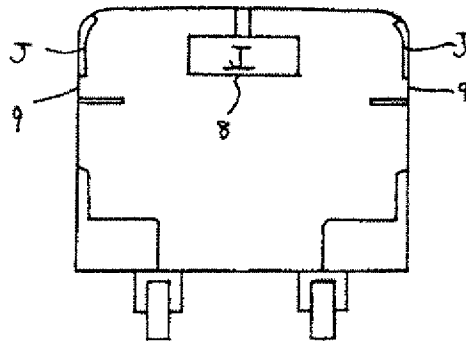
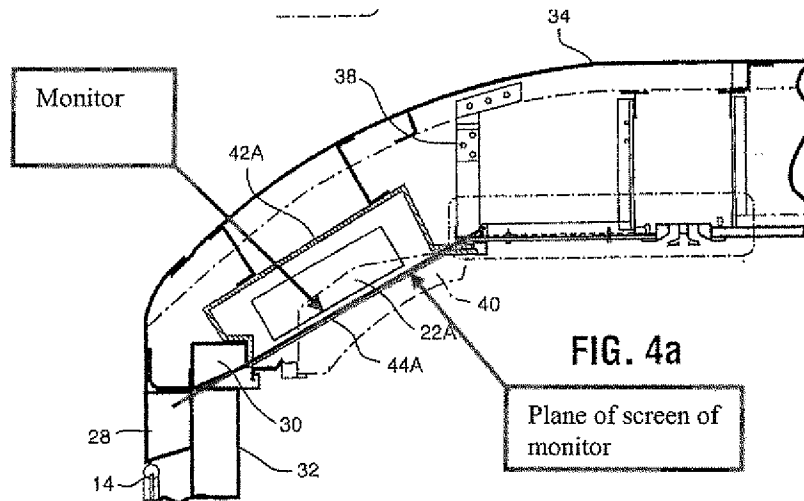

Figure 2 of Minesaki

As can be seen, there is not a single part of the information transmission display (part J) illustrated in Fig. 2 which can reasonably be considered to be flush with the adjacent wall surface (as Patent Owner has used that term in its specification and Claim 1); in fact, the entire information transmission display part J of Minesaki clearly protrudes away from the adjacent wall surface. Patent Owner refers the Office to FIG. 4a of its specification (reproduced below for convenience), which clearly shows an embodiment of Patent Owner’s invention that has a screen that is substantially flushed with the adjacent wall surface (as explicitly recited in Claim 1), and with no protrusion of the display (as occurs in Minesaki). As indicated in Patent Owner’s specification regarding FIG. 4a, (See, e.g. Col 5, lines 42 – 45 of Patent Owner’s specification) this configuration gives a better aesthetic appearance to the inside of the subway car as a whole, as well as improving the display performance by minimizing the interference effects.



r. 2, 2004
Sheet 4 of 6
US 6,700,602 B1

5 Accordingly, Patent Owner respectfully submits that the Office's interpretation of the term
"substantially flushed" is improper, as the Office's interpretation completely reads out the claimed
"flushed" feature, and obscures what is meant by "substantially flushed" as clearly described
throughout Patent Owner's specification and figures. Patent Owner's specification clearly describes
a subway car with video monitors that appear integral with the design of the subway car (see, e.g.,
10 Col. 4, lines 8 – 13 of Patent Owner's specification). Furthermore, the Patent Owner's specification
and figures are indicative of monitors that are built within the inner spaces and below the surface
structure of the interior of the subway car so as to achieve the stated goal of making the video
display monitors appear integral with the inside structure of the subway car (see e.g., Col. 3, line 55
to Col. 4, line 9). No attempt has been made by Minesaki to expressly place the information
15 transmission display parts within the inner spaces of the adjacent interior surface structure of the
car, nor is Minesaki concerned about having the information transmission display parts screen
"substantially flush" with the adjacent surface structure. In response to Patent Owner's previous
assertions, the Office states that the term flush is "examined as 'forming a continuous plane or
unbroken surface.'" Furthermore, the Office alleges that the screen of the display monitor
20 illustrated in FIG. 4a above can never form a continuous plane or unbroken surface with the
adjacent wall surface structure. However, the Office alleges that this is the case because the screen
is further behind the transport screen of the enclosure (see page 103 of the *Ex Parte* Office Action).
Patent Owner submits that although the screen of the monitor is behind the transport screen in the
illustrated embodiment, the use of the transport screen would give the appearance of a flush
25 mounted monitor (e.g., "substantially flush"), even though the screen of the monitor would actually
be slightly offset from the adjacent wall surface structure of the car. Again, contrast with Minesaki,
which illustrates information transmission display parts which would clearly not give the
appearance of a flush mounted monitor, instead showing its information transmission display parts
sitting on top of the wall surface. In fact, if the drawings of Minesaki were taken literally, the
30 information transmission display parts would protrude out from the wall approximately four (4)
times the thickness of the wall, or alternatively, would protrude away from the wall at a distance
approximately equal to the back portion of the seats illustrated in Minesaki. Clearly, such a
configuration cannot be considered to be "substantially flush".

Control No. : 90/011,861
Filed : August 16, 2011

5 Furthermore, “it is well established that patent drawings do not define the precise proportions of the elements and may not be relied on to show particular sizes if the specification is completely silent on the issue.” *Hockerson-Halberstadt, Inc. v. Avia Group Int’l*, 222 F.3d 951, 956, 55 USPQ2d 1487, 1491 (Fed. Cir. 2000) Per page 7 of the *Ex Parte* Advisory Action, the Office alleges that Minesaki discloses a “liquid crystal panel” that would have a low profile and hence would be “substantially flush” as claimed. However, Patent Owner notes that Minesaki never states that the liquid crystal panels are low profile and even assuming, *arguendo*, that they are low profile, a low profile monitor would not by itself be “substantially flush” as claimed.

10 Finally, Patent Owner respectfully submits that Minesaki does not expressly or inherently describe that “the screen of the monitor ... [is] directed obliquely downwardly toward the car seats”. While Patent Owner admits that the information transmission display parts J of Minesaki appear curved with the top portion seemingly directed obliquely downwardly, the majority portion of the information transmission display part J is directed perpendicular to the sidewall of the
15 Minesaki train (see Fig. 2 reproduced above). Furthermore, Patent Owner has set forth and claimed in Claim 1 that “the screen of the monitor ... [is] directed obliquely downwardly toward the car seats” as opposed to setting forth and claiming that only portions of the screen of the monitor are directed obliquely downwardly. In response, the Office states that since portions of the monitor screen of Minesaki are directed obliquely downward toward the car seats, Minesaki fully meets
20 Patent Owner’s claimed language. However, Patent Owner has actually claimed “the screen of the monitor ... directed obliquely downwardly toward the car seats, so that each video screen is readily visible to passengers in the subway car.” Furthermore, the stated reasoning in Patent Owner’s specification states that the screen is: “suitably angled downwardly, for best viewing by passengers seated opposite the screen” (Col. 4, lines 6 – 7 of the ‘602 Patent); “angled downwardly for ease of viewing of passengers 24 seated in such inward facing seats 16” (Col. 5, lines 1 – 2 of the ‘602 Patent); and “angled downwardly for best viewing by a passenger 24 seated opposite” (Col. 5, lines 30 – 32 of the ‘602 Patent). Patent Owner respectfully submits that the arrangement illustrated in Minesaki would frustrate the ability for each video screen to be readily visible to passengers if only a portion of the screen were directed obliquely downwardly
30 (due to *inter alia*, optical distortion associated with only the very top portion of light emanating from the screen), and that the Office’s interpretation of Patent Owner’s language is inconsistent with Patent Owner’s specification.

35 Accordingly, Patent Owner submits that Claim 1 distinguishes on this independent and distinct basis as well.

II. Rejection of Claim 1 Under 35 U.S.C. § 102 as Being Anticipated by Amano

40 **Claim 1** – With regards to the Office’s rejection of Claim 1 as being anticipated by Amano, Patent Owner respectfully traverses. Specifically, Patent Owner respectfully submits that Amano fails to expressly or inherently describe “the screen of the monitor substantially flushed with the adjacent wall surface structure of the car”.

45 Again, the Office alleges that the term “substantially” is often used in conjunction with another term to describe a particular characteristic of the claimed invention and is further construed to be a broad term (citing MPEP §2173.05). Again, Patent Owner respectfully submits that the use

of the term "substantially" cannot be construed so broadly as to read the term "flushed" completely out of the claim. Figures 4 – 6 of Amano are reproduced below for the convenience of the Office.

Figure 4

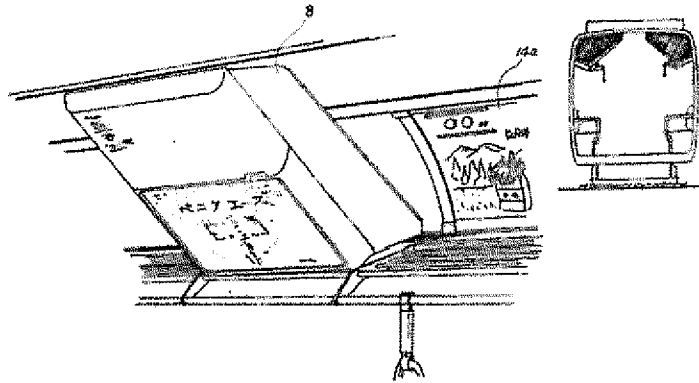

5

Figure 4 of Amano

Figure 5

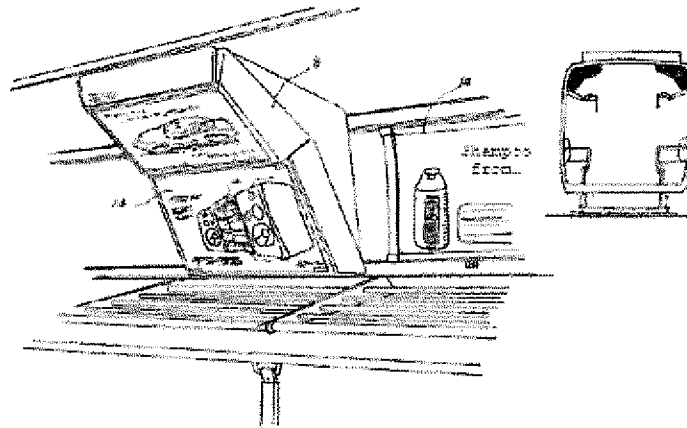

Figure 5 of Amano

Figure 6

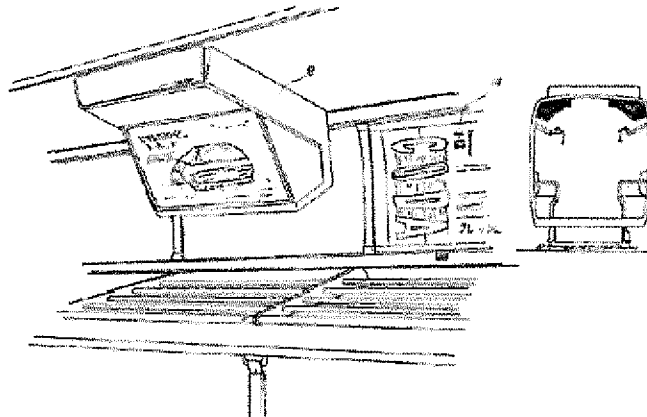

Figure 6 of Amano

10

Control No. : 90/011,861
Filed : August 16, 2011

As can be seen, there is not a single part of the information display device 8 illustrated in Figures 4 – 6 that can reasonably be considered to be “flush with the adjacent wall surface” as recited in Claim 1. In fact, the entire information display device 8 of Amano (including the screen, which is the component Patent Owner’s Claim 1 recites as being substantially flushed with the wall surface) clearly protrudes away from the adjacent wall surface. Patent Owner respectfully submits that the Office’s interpretation of the term “substantially flushed” is improper, as the Office’s interpretation completely reads out the “flushed” feature and obscures what is meant by “substantially flushed” as clearly described throughout Patent Owner’s specification and figures. Patent Owner’s specification clearly describes a subway car with video monitors that appear integral with the design of the subway car (see, e.g., Col. 4, lines 8 – 13 of Patent Owner’s specification). Furthermore, the Patent Owner’s specification and figures are indicative of monitors that are built within the inner spaces and below the surface structure of the interior of the subway car so as to achieve the stated goal of making the video display monitors appear integral with the inside structure of the subway car (see e.g., Col. 3, line 55 to Col. 4, line 9). No attempt has been made by Amano to expressly place the information transmission display parts within the inner spaces of the adjacent interior surface structure of the car, nor is Amano concerned about having the information transmission display parts screen “substantially flush” with the adjacent surface structure. See again FIG. 4a of the ‘602 Patent discussed *supra*.

In response to Patent Owner’s previous assertions, the Office states that the term flush is “examined as *forming a continuous plane or unbroken surface.*” Furthermore, the Office alleges that the screen of the display monitor illustrated in FIG. 4a above can never form a continuous plane or unbroken surface with the adjacent wall surface structure. However, the Office alleges that this is the case because the screen is further behind the transport screen of the enclosure (see page 108 of the *Ex Parte* Office Action). Patent Owner submits that although the screen of the monitor is behind the transport screen in the illustrated embodiment, the use of the transport screen would give the appearance of a flush mounted monitor (e.g., “substantially flush”), even though the screen of the monitor would actually be slightly offset from the adjacent wall surface structure of the car. Again, contrast with Amano which illustrates information display devices which would clearly not give the appearance of a flush mounted monitor.

Accordingly, Patent Owner respectfully submits that the Office’s rejection of Claim 1 as being anticipated by Amano is improper, and should be withdrawn.

III. Rejection of Claim 1 Under 35 U.S.C. § 103 as Being Obvious over Maekawa in View of Amano

Claim 1 – With regards to Claim 1, the Office admits that Maekawa does not specifically disclose monitors that are mounted at the junction of the sidewall and ceiling and directed obliquely downwardly toward the car seats (see pages 8 – 9 of the Final *Ex Parte* Office Action). However, the Office alleges that such a feature is taught by Amano. Patent Owner respectfully directs the Office’s attention towards the discussion of Amano *supra*. Furthermore, the Office alleges that Maekawa expressly discloses that the screen of the monitor is substantially flushed with the adjacent wall surface structure of the car, citing features 101 – 124, page 738, column 2, and Figures 1 and 2 of Maekawa. Patent Owner respectfully traverses.

Specifically, Maekawa fails to teach or suggest that “the screen of the monitor [is] substantially flushed with the adjacent wall surface structure of the car”. Page 738, column 2 of Maekawa states in relevant part: “...each of the television receivers (101), (102), (103) ... (124) is made low profile using liquid crystal panels or the like.” Accordingly, while Maekawa clearly contemplates low profile displays, Maekawa is completely silent as to these liquid crystal panels being “substantially flush” with the adjacent wall surface structure of the car.

Again, the Office alleges that the term “substantially” is often used in conjunction with another term to describe a particular characteristic of the claimed invention and is further construed to be a broad term (citing MPEP §2173.05). However, Patent Owner respectfully submits that the use of the term “substantially” cannot be construed so broadly as to read the term “flushed” completely out of the claim; see discussion provided *supra*. Figure 2 of Maekawa illustrates that no part of these low profile displays are “flush” with the adjacent wall surface structure of the car as Patent Owner has used that term in its specification and Claim 1. Figure 2 of Maekawa is reproduced below for the convenience of the Office.

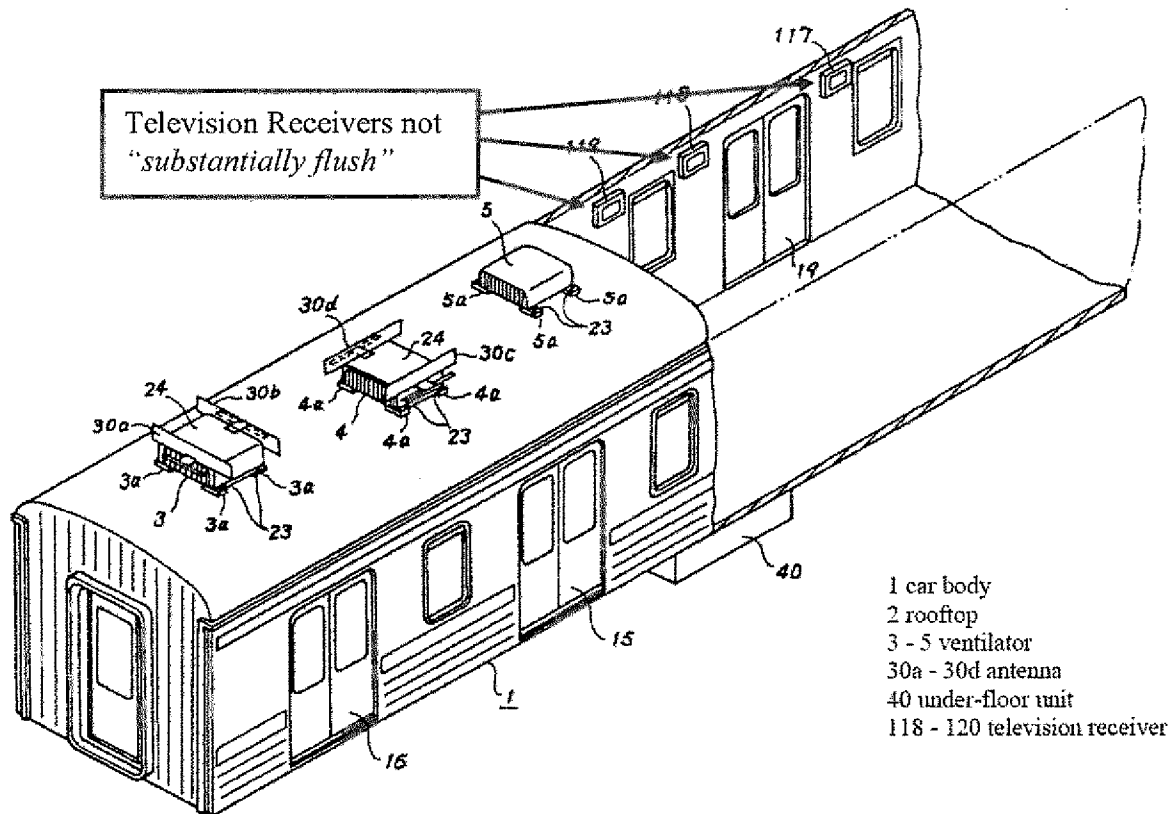

Figure 2 of Maekawa

As can be seen, there is not a single part of the television receiver illustrated in Figure 2 (including especially its screen) that is flush with the adjacent wall surface structure of the car; in fact, the entire television receiver of Maekawa clearly protrudes from the adjacent car wall surface, or sits on top of the adjacent wall surface, by an amount roughly equal to the thickness of the wall itself. Accordingly, Patent Owner respectfully submits that the Office’s interpretation of the term “substantially flushed” is improper, as the Office’s interpretation completely reads out the “flushed” feature.

Control No. : 90/011,861
Filed : August 16, 2011

Patent Owner further submits that Amano does not cure the deficiencies present in Maekawa (see discussion of Amano with regards to the Office's 35 U.S.C. § 102 rejection above).

5 In response to Patent Owner's previous assertions, the Office states that the term flush is
"examined as *forming a continuous plane or unbroken surface.*" Furthermore, the Office alleges
that the screen of the display monitor illustrated in FIG. 4a above can never form a continuous
plane or unbroken surface with the adjacent wall surface structure. However, the Office alleges that
10 this is the case because the screen is further behind the transport screen of the enclosure (see page
112 of the *Ex Parte* Office Action). Patent Owner submits that although the screen of the monitor
is behind the transport screen in the illustrated embodiment, the use of the transport screen would
give the appearance of a flush mounted monitor ("*substantially flush*"), even though the screen of
the monitor would actually be slightly offset from the adjacent wall surface structure of the car.
Again, contrast with Maekawa which illustrates information display devices which would clearly
15 not give the appearance of a flush mounted monitor, instead showing its monitors sitting on top of
the wall surface.

Accordingly, the Office's rejection of Claim 1 as being obvious over Maekawa in view of Amano is respectfully improper and should be withdrawn.

20 **IV. Rejection of Claim 1 Under 35 U.S.C. § 103 as Being Obvious over Minesaki in View of Moore**

Claim 1 – Patent Owner respectfully traverses the Office's contention that Claim 1 is
obvious over Minesaki in view of Moore. Specifically, and as discussed previously herein with
25 regards to Patent Owner's discussion of Minesaki *supra*, Minesaki fails to teach or suggest: (1)
"*each of said monitor being mounted at the junction of the sidewall and ceiling*"; and (2) "*directed
obliquely downwardly toward the car seats*". See, e.g., the discussion with regards to the 35 U.S.C.
§ 102 rejection of Minesaki discussed *supra*.

30 Furthermore, Patent Owner submits that Moore does not cure the deficiencies found in
Minesaki, as Moore is only being utilized for its teaching of a monitor adapted to be mounted flush
with a surrounding wall, and teaches nothing of the placement of the monitor within the wall (e.g.,
at a junction or otherwise).

35 Patent Owner also submits that the Office's combination of Minesaki and Moore constitutes
impermissible hindsight reasoning. Specifically, Patent Owner notes that:

40 "*[a]ny judgement on obviousness is in a sense necessarily a
reconstruction based on hindsight reasoning, but so long as it takes into account
only knowledge which was within the level of ordinary skill in the art at the time
the claimed invention was made and does not include knowledge gleaned only
from applicant's disclosure, such a reconstruction is proper.*" *In re McLaughlin*,
443 F.2d 1392, 1395 (CCPA 1971).

45 Per page 11 of the Final *Ex Parte* Office Action, the Office alleges that:

Control No. : 90/011,861
Filed : August 16, 2011

5 *"It would have been obvious to one of ordinary skill in the art at the time of the invention as made to modify the monitor being projecting slightly beyond the adjacent wall surface structure of the car of Minesaki with the screen of the monitor being substantially flushed with the adjacent wall surface structure of Moore et al. in order to provide a means to compensate for wall thickness or, the availability of space beyond the surface of the wall."* {emphasis added}

10 The requisite motivation (i.e., *"to provide a means to compensate for wall thickness ..."*) is alleged to be disclosed at Col. 7, lines 44 – 47. However, Col. 7, lines 44 – 47 of Moore actually states:
15 *"[t]he type of installation depends on the available wall thickness, or the availability of space beyond the wall into which the rear end of the monitor may project."* However, nothing within the teachings of Minesaki teaches or suggests the availability of space beyond the wall into which the rear end of the monitor may project. Accordingly, Patent Owner submits that the only such reasoning for making such a combination is gleaned entirely from Patent Owner's disclosure, as
20 nothing within the teachings of Minesaki suggests the availability of space or the desirability of the proposed combination. Accordingly, Patent Owner respectfully submits that the Office's reasoning constitutes impermissible hindsight reasoning.

25 Accordingly, Patent Owner respectfully submits that the Office's rejection of Claim 1 as being unpatentable over Minesaki in view of Moore is improper and should be withdrawn.

30 **V. Rejection of Claim 1 Under 35 U.S.C. § 103 as Being Obvious over Amano in View of Moore**

35 **Claim 1** – Patent Owner respectfully traverses the Office's rejection of Claim 1 as being unpatentable over Amano in view of Moore. Specifically, and as discussed previously herein with regards to Patent Owner's discussion of Amano *supra*, Amano fails to teach or suggest *"each of said monitor being mounted at the junction of the sidewall and ceiling"*. See, e.g., the discussion with regards to the 35 U.S.C. § 102 rejection of Amano discussed *supra*.

40 Furthermore, the Office alleges, in part, that it would have been obvious for one of ordinary skill in the art to arrive at *"the screen of the monitor [being] substantially flushed with the adjacent wall surface structure of the car"* by combining the monitors mounted near the junction of the sidewall and ceiling of Amano (see Figures 4 – 6 of Amano) with the teaching of a monitor adapted to be mounted flush with a surrounding wall as taught by Moore. Patent Owner respectfully disagrees and traverses.

45 MPEP §2143.03(VI) states that: *"[a] prior art reference must be considered in its entirety, i.e., as a whole, including portions that would lead away from the claimed invention."* Accordingly, where cited art teaches away from a claimed feature, the cited art is not available for the purposes of an obviousness rejection.

 Furthermore, if the *"proposed modification would render the prior art invention being modified unsatisfactory for its intended purpose, then there is no suggestion or motivation to make the proposed modification. In re Gordon, 733 F.2d 900, 221 USPQ 1125 (Fed. Cir. 1984)"*. See also MPEP §2143.01.

In the instant case, Amano fails to teach or suggest “the screen of the monitor [being] substantially flushed with the adjacent wall surface structure of the car”. However, the Office states that the monitor of Amano can readily and predictably be substituted with the flush monitor of Moore. To the contrary, Patent Owner respectfully submits that the wall structure of Amano (in particular, the area near the junction of the sidewall and ceiling) would need to be appreciably modified in order to accommodate a flush monitor. See also, for example, FIG. 4a of the ‘602 Patent. However, Amano also illustrates storage areas on the upper areas of the train. See for example, Figure 4 of Amano reproduced below.

Figure 4

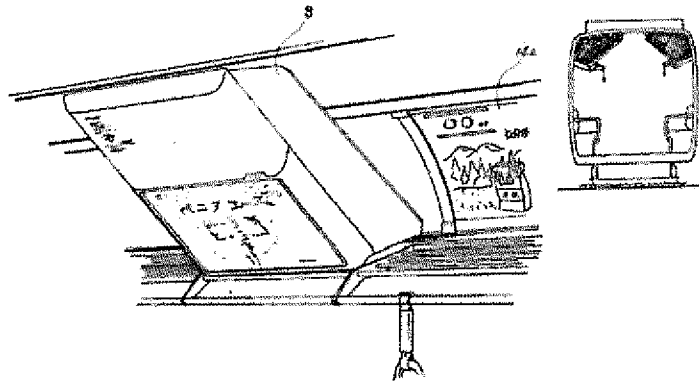

Figure 4 of Amano

Accordingly, modifications to the area near the junction of the sidewall and ceiling of the Amano train would render the Amano train unsatisfactory for its intended purpose. For example, if the wall surface structure near the information display device 8 were to be extended so that the screen of the information display device 8 were “substantially flushed” with its adjacent walls, the storage areas would need to be substantially reduced in size or eliminated entirely. It is not clear to Patent Owner why one would be motivated to make such a modification, where the modification would remove desirable storage area on the train of Amano, thereby leading to a situation where no overhead storage is available for passengers’ luggage or other items. By analogy, one would not design a commercial airliner such that no overhead storage was available (thereby requiring passengers to check all baggage).

Note also that the cross-sectional view in FIG. 4 of Amano reproduced above shows a thin outer shell or body for the train car with seemingly little or no interior volume of space, thereby frustrating mounting of the monitor screen flush therewith (otherwise, the back of the monitor, wiring, etc., would protrude through the car body and be exposed on the outside), which is clearly undesirable.

Furthermore, it is a stated purpose of Amano to take the opportunity to effectively use the time on a transportation vehicle to provide various information to people who are using various cited transportation vehicles (i.e., airplane, train and bus). Accordingly, if Amano were modified so that the display devices 8 were flush with the adjacent wall surface structure of the car, and the storage areas were modified to protrude further away from the sidewall to accommodate for the space taken up by the flush mounted monitors, passengers would place luggage or other articles

Control No. : 90/011,861
Filed : August 16, 2011

onto these storage areas thereby obscuring the display of information on these display devices from the passengers on the transportation vehicle, in direct contravention with the stated purpose of Amano.

5 Amano does not appear to explicitly describe the reasoning behind the placement of the information signal display devices near the junction of the ceiling and the sidewall. However, it appears reasonable to infer that since each of the respective embodiments which illustrate this feature (i.e. FIGS. 4 – 6) also include areas for overhead storage, that the placement of the information signal display devices is merely necessitated because of the existence of these
10 overhead storage areas; i.e., they would not otherwise be able to be accommodated on the sidewall areas as illustrated in, for example, Maekawa, as the overhead storage areas interface with the sidewall in these traditional information signal display device mounting areas.

15 In addition, Patent Owner also submits that the Office’s combination of Amano and Moore constitutes impermissible hindsight reasoning. Specifically, Patent Owner notes that:

20 *“[a]ny judgement on obviousness is in a sense necessarily a reconstruction based on hindsight reasoning, but so long as it takes into account only knowledge which was within the level of ordinary skill in the art at the time the claimed invention was made and does not include knowledge gleaned only from applicant’s disclosure, such a reconstruction is proper.” In re McLaughlin, 443 F.2d 1392, 1395 (CCPA 1971).*

25 Per pages 14 – 15 of the Final *Ex Parte* Office Action, the Office alleges that:

30 *“It would have been obvious to one of ordinary skill in the art at the time of the invention as made to modify the monitor being projecting slightly beyond the adjacent wall surface structure of the car of Amano et al. with the screen of the monitor being substantially flushed with the adjacent wall surface structure of Moore et al. in order to provide a means to compensate for wall thickness or, the availability of space beyond the surface of the wall.” {emphasis added}*

35 The requisite motivation (i.e., “to provide a means to compensate for wall thickness”) is alleged to be disclosed at Col. 7, lines 44 – 47. However, Col. 7, lines 44 – 47 of Moore actually states: “[t]he type of installation depends on the available wall thickness, or the availability of space beyond the wall into which the rear end of the monitor may project.” However, nothing within the teachings of Amano teaches or suggests the availability of space beyond the wall into which the rear end of the monitor may project. Accordingly, Patent Owner submits that the only such reasoning for making such a combination is gleaned entirely from Patent Owner’s disclosure, as nothing within
40 the teachings of Amano suggests the availability of space or the desirability of the proposed combination. Accordingly, Patent Owner respectfully submits that the Office’s reasoning constitutes impermissible hindsight reasoning.

45 Therefore, as the proposed modification to Amano would render the Amano storage areas (or information display devices 8) unsatisfactory for their intended purpose, one of ordinary skill in the art would not be motivated to modify Amano to incorporate certain features of Moore in an

Control No. : 90/011,861
Filed : August 16, 2011

effort to arrive at the claimed invention. Accordingly, Patent Owner respectfully submits that the rejection is improper and respectfully requests that the rejection be withdrawn.

5 **VI. Rejection of Claim 1 Under 35 U.S.C. § 103 as Being Obvious over Maekawa and/or Shinagawa in View of Amano and Moore**

10 **Claim 1** – In each of these respective instances, Maekawa and Shinagawa are both alleged to disclose all of the limitations of the claimed invention, except for specifically calling for each of the monitors to be mounted at the junction of the sidewall and ceiling and directed obliquely downwardly toward the car seats, with the screen of the monitor being substantially flushed with the adjacent wall surface structure. However, the Office utilizes Amano in combination with Moore to allegedly teach such features as claimed.

15 However, as discussed previously herein, Patent Owner respectfully submits that the proposed combination of Amano and Moore is improper, as the modification of Amano to include the flush monitors of Moore would render the Amano storage areas (or information display devices 8) unsatisfactory for their intended purpose. Accordingly, as the proposed modification would render the “*prior art invention being modified unsatisfactory for its intended purpose ... there is no suggestion or motivation to make the proposed modification*”.

20 In addition, Patent Owner also submits that the Office’s combination of Amano and Moore constitutes impermissible hindsight reasoning. Specifically, Patent Owner notes that:

25 “*[a]ny judgement on obviousness is in a sense necessarily a reconstruction based on hindsight reasoning, but so long as it takes into account only knowledge which was within the level of ordinary skill in the art at the time the claimed invention was made and does not include knowledge gleaned only from applicant's disclosure, such a reconstruction is proper.*” *In re McLaughlin*, 443 F.2d 1392, 1395 (CCPA 1971).

30 Per pages 18 – 19 of the Final *Ex Parte* Office Action, the Office alleges that:

35 “*It would have been obvious to one of ordinary skill in the art at the time of the invention as made to modify the monitor being projecting slightly beyond the adjacent wall surface structure of the car of Maekawa et al. with the screen of the monitor being substantially flushed with the adjacent wall surface structure of Moore et al. in order to provide a means to compensate for wall thickness or, the availability of space beyond the surface of the wall.*” {emphasis added}

40 The requisite motivation (i.e., “*to provide a means to compensate for wall thickness*”) is alleged to be disclosed at Col. 7, lines 44 – 47. However, Col. 7, lines 44 – 47 of Moore actually states: “[*t*]he type of installation depends on the available wall thickness, or the availability of space beyond the wall into which the rear end of the monitor may project.” However, nothing within the teachings of Maekawa teaches or suggests the availability of space beyond the wall into which the rear end of the monitor may project. Accordingly, Patent Owner submits that the only such reasoning for making such a combination is gleaned entirely from Patent Owner’s disclosure, as

Control No. : 90/011,861
Filed : August 16, 2011

nothing within the teachings of Maekawa suggests the availability of space or the desirability of the proposed combination. Accordingly, Patent Owner respectfully submits that the Office's reasoning constitutes impermissible hindsight reasoning.

5 Patent Owner respectfully requests withdrawal of the Office's rejection of Claim 1 as being unpatentable over Maekawa in view of Amano and further in view of Moore; or alternatively as being unpatentable over Shinagawa in view of Amano and further in view of Moore.

10 Respectfully submitted,
GAZDZINSKI & ASSOCIATES, PC

Dated: March 18, 2013

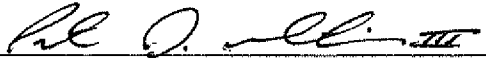
By: 
Peter J. Gutierrez, III,
Reg. No. 56,732
16644 West Bernardo Drive, Suite 201
San Diego, CA 92127
Telephone No.: (858) 675-1670
Facsimile No.: (858) 675-1674

15

Control No. : 90/011,861
Filed : August 16, 2011

APPENDIX I - CLAIMS

1. A subway car for mass transportation including longitudinal opposed sidewalls, a
5 ceiling adjoining the sidewalls, a video display system comprising a plurality of video display
monitors each having a video screen, and a video signal source unit operatively connected to said
monitors,

said monitors being spaced along the length of the car on opposed sides thereof, each of
said monitor being mounted at the junction of the sidewall and ceiling, with the screen of the
10 monitor substantially flushed with the adjacent wall surface structure of the car, and directed
obliquely downwardly toward the car seats, so that each video screen is readily visible to
passengers in the subway car.

2. The subway car of claim 1 wherein the video signal source system includes a pre-
recorded video transmission program for feeding to display on the monitors of duration about 5-
15 15 minutes.

3. The subway car of claim 1 wherein the program is repeatable, and includes a
series of commercial messages of 30 second-1 minute duration.

4. The video system subway car of claim 1 which is sound free.

5. The subway car of claim 1 wherein the video signal source unit comprises a video
20 tape player, a video disk player or computer-based digital video recorder.

6. The subway car of claim 1 wherein the video monitors include LCD screens.

7. The subway car of any of claim 1 including a self-contained wiring-cabling
system connecting the video monitors to the video signal source unit.

8. (Amended) A subway car for mass transportation, comprising:
25 a video display system comprising a plurality of video display monitors each having a
video screen, and a video signal source unit operatively connected to said video display monitors;
a plurality of transparent cover units that cover respective ones of the video display
monitors;

a pair of longitudinal opposed sidewalls, each of the sidewalls comprising a transitional
30 wall portion at the junction of the sidewall and ceiling that is directed obliquely downwardly; and
a ceiling adjoining the sidewalls;

Control No. : 90/011,861
Filed : August 16, 2011

5 wherein the monitors are spaced along the length of the car on opposed sides thereof, the monitors being disposed within the transitional wall portion such that the transparent cover units covering respective ones of the video display monitors are substantially flush with the adjacent surface structure of the transitional wall portion, wherein the monitors are also directed obliquely downwardly toward the car seats so that each video screen is readily visible to passengers in the subway car.

9. (Amended) The subway car of Claim 8, wherein the plurality of transparent cover units are rigid and are further configured to protect the video display monitor.

10 10. The subway car of Claim 9, wherein the video display monitor is disposed within the transitional wall portion such that it contains no visible edges or protuberances.

11. The subway car of Claim 8, further comprising a back lit panel disposed on the transitional wall portion, the back lit panel disposed adjacent the video screen of the video display monitor.

15 12. The subway car of Claim 8, wherein the video display monitors are each enclosed within an enclosure.

13. The subway car of Claim 12, wherein the enclosure is secured to a structural member disposed between an inner wall and an outer structural shell of the subway car.

14. The subway car of Claim 13, wherein the enclosure and a respective video display monitor is removable from the subway car as a unit.

20 15. (Amended) A subway car for mass transportation including longitudinal opposed sidewalls that further comprise a transitional segment and a ceiling adjoining the sidewalls with the transitional segment disposed at the junction of the sidewall and the ceiling, the subway car further comprising:

a video display system comprising:

25 a plurality of video display monitors each having a video screen; and

a video signal source unit operatively connected to said video display monitors;

wherein said video display monitors are spaced along the length of the car on opposing sides of the subway, each of the video display monitors being mounted within the transitional segment, with the video screen of each video display monitor being substantially contiguous with an exterior surface of said transitional segment, said video screen being directed obliquely

30

Control No. : 90/011,861
Filed : August 16, 2011

downwardly toward the car seats so that each video screen is readily visible to passengers in the subway car; and

a back lit panel disposed on the transitional segment disposed adjacent the ceiling and a respective sidewall.

5 16. The subway car of Claim 15, wherein an external surface of the longitudinal opposed sidewall, the exterior surface of said transitional segment and an external surface of the ceiling comprise a blended contour.

17. The subway car of Claim 15, wherein the video signal source unit is configured to display a series of short messages in sequence on said plurality of video display monitors.

10 18. The subway car of Claim 17, wherein the series of short messages comprise advertising content, said advertising content providing an additional source of revenue for the operator of the subway car.

19. (Cancelled)

15 20. (Amended) The subway car of Claim 15, wherein the back lit panel is disposed adjacent the video screen of the video display monitor.

21. (Amended) A subway car for mass transportation including longitudinal opposed sidewalls, a ceiling adjoining the sidewalls, a video display system comprising a plurality of video display monitors each having a video screen, and a video signal source unit operatively connected to said monitors,

20 said monitors being spaced along the length of the car on opposed sides thereof, each of said monitors being mounted at the junction of the sidewall and ceiling and further being covered with a transparent cover unit, with the transparent cover unit flushed with the adjacent wall surface structure of the car, and with the monitors directed obliquely downwardly toward the car seats, so that each video screen is readily visible to passengers in the subway car.

25 22. (Amended) The subway car of Claim 21, wherein the transparent cover unit for a respective video display monitor is rigid and is further configured to protect the video display monitor.

23. (Amended) The subway car of Claim 21, wherein the transparent cover unit is flushed within the adjacent wall structure such that it contains no protuberances.

30 24. The subway car of Claim 21, further comprising a back lit panel disposed on the adjacent wall surface structure of the car.

Control No. : 90/011,861
Filed : August 16, 2011

25. The subway car of Claim 21, wherein the video display monitors are each enclosed within an enclosure.

26. The subway car of Claim 25, wherein the enclosure is secured to a structural member disposed between an inner wall and an outer structural shell of the subway car.

5 27. The subway car of Claim 26, wherein the enclosure and a respective video display monitor is removable from the subway car as a unit.

28. The subway car of Claim 21, wherein an external surface of the longitudinal opposed sidewalls, the adjacent wall surface structure and an external surface of the ceiling comprise a blended contour.

10 29. The subway car of Claim 21, wherein the video signal source unit is configured to display a series of short messages in sequence on said plurality of video display monitors.

30. The subway car of Claim 29, wherein the series of short messages comprise advertising content, said advertising content providing an additional source of revenue for the operator of the subway car.

15

Control No. : 90/011,861
Filed : August 16, 2011

APPENDIX II - EVIDENCE

NONE

5

Control No. : 90/011,861
Filed : August 16, 2011

APPENDIX III - RELATED PROCEEDINGS

NONE

Electronic Acknowledgement Receipt

EFS ID:	14743428
Application Number:	90011861
International Application Number:	
Confirmation Number:	3736
Title of Invention:	SUBWAY TV MEDIA SYSTEM
First Named Inventor/Applicant Name:	6700602
Customer Number:	27299
Filer:	Peter John Gutierrez III
Filer Authorized By:	
Attorney Docket Number:	BLAIR.001A
Receipt Date:	18-JAN-2013
Filing Date:	16-AUG-2011
Time Stamp:	17:52:26
Application Type:	Reexam (Patent Owner)

Payment information:

Submitted with Payment	yes
Payment Type	Deposit Account
Payment was successfully received in RAM	\$ 1260
RAM confirmation Number	5518
Deposit Account	501423
Authorized User	

The Director of the USPTO is hereby authorized to charge indicated fees and credit any overpayment as follows:

Charge any Additional Fees required under 37 C.F.R. Section 1.16 (National application filing, search, and examination fees)

Charge any Additional Fees required under 37 C.F.R. Section 1.17 (Patent application and reexamination processing fees)

Charge any Additional Fees required under 37 C.F.R. Section 1.19 (Document supply fees)
 Charge any Additional Fees required under 37 C.F.R. Section 1.20 (Post Issuance fees)
 Charge any Additional Fees required under 37 C.F.R. Section 1.21 (Miscellaneous fees and charges)

File Listing:

Document Number	Document Description	File Name	File Size(Bytes)/ Message Digest	Multi Part /.zip	Pages (if appl.)
1	Petition for review by the Office of Petitions.	Petition.pdf	76650 853593e9882d2a356920a04c724c52da854380fd	no	2

Warnings:

Information:

2	Notice of Appeal Filed	NTC_of_Appeal.pdf	53964 8b6b42fa05468e01a7b271c51e1863a61f289ab6	no	1
---	------------------------	-------------------	---	----	---

Warnings:

Information:

3	Fee Worksheet (SB06)	fee-info.pdf	32014 9e541d0c6e4bea50a8b9340fe3c9098f47f6c8e0	no	2
---	----------------------	--------------	---	----	---

Warnings:

Information:

Total Files Size (in bytes): 162628

This Acknowledgement Receipt evidences receipt on the noted date by the USPTO of the indicated documents, characterized by the applicant, and including page counts, where applicable. It serves as evidence of receipt similar to a Post Card, as described in MPEP 503.

New Applications Under 35 U.S.C. 111

If a new application is being filed and the application includes the necessary components for a filing date (see 37 CFR 1.53(b)-(d) and MPEP 506), a Filing Receipt (37 CFR 1.54) will be issued in due course and the date shown on this Acknowledgement Receipt will establish the filing date of the application.

National Stage of an International Application under 35 U.S.C. 371

If a timely submission to enter the national stage of an international application is compliant with the conditions of 35 U.S.C. 371 and other applicable requirements a Form PCT/DO/EO/903 indicating acceptance of the application as a national stage submission under 35 U.S.C. 371 will be issued in addition to the Filing Receipt, in due course.

New International Application Filed with the USPTO as a Receiving Office

If a new international application is being filed and the international application includes the necessary components for an international filing date (see PCT Article 11 and MPEP 1810), a Notification of the International Application Number and of the International Filing Date (Form PCT/RO/105) will be issued in due course, subject to prescriptions concerning national security, and the date shown on this Acknowledgement Receipt will establish the international filing date of the application.

Under the Paperwork Reduction Act of 1995, no persons are required to respond to a collection of information unless it displays a valid OMB control number.

NOTICE OF APPEAL FROM THE EXAMINER TO THE PATENT TRIAL AND APPEAL BOARD	Docket Number (Optional) BLAIR.001A
--	---

I hereby certify that this correspondence is being facsimile transmitted to the USPTO, EFS-Web transmitted to the USPTO, or deposited with the United States Postal Service with sufficient postage in an envelope addressed to "Commissioner for Patents, P.O. Box 1450, Alexandria, VA 22313-1450" [37 CFR 1.8(a)] on _____ Signature _____ Typed or printed name _____	In re Application of Scott Blair	
	Application Number 90/011,861	Filed August 16, 2011
	For SUBWAY TV MEDIA SYSTEM	
	Art Unit 3992	Examiner Stephen Ralis

Applicant hereby **appeals** to the Patent Trial and Appeal Board from the last decision of the examiner.

The fee for this Notice of Appeal is (37 CFR 41.20(b)(1)) \$ 315

Applicant claims small entity status. See 37 CFR 1.27. Therefore, the fee shown above is reduced by half, and the resulting fee is: \$ _____

A check in the amount of the fee is enclosed.

Payment by credit card. Form PTO-2038 is attached.

The Director has already been authorized to charge fees in this application to a Deposit Account.

The Director is hereby authorized to charge any fees which may be required, or credit any overpayment to Deposit Account No. 501423

Payment made via EFS-Web.

A petition for an extension of time under 37 CFR 1.136(a) (PTO/SB/22 or equivalent) is enclosed.

WARNING: information on this form may become public. Credit card information should not be included on this form. Provide credit card information and authorization on PTO-2038.

I am the

applicant.

attorney or agent of record.
 Registration number 56,732

attorney or agent acting under 37 CFR 1.34
 Registration number if acting under 37 CFR 1.34 _____

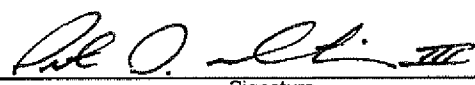

 Signature
Peter J. Gutierrez, III

 Typed or printed name
(858) 675-1670

 Telephone number

January 18, 2013

 Date

NOTE: This form must be signed in accordance with 37 CFR 1.33. See 37 CFR 1.4 for signature requirements and certifications. Submit multiple forms if more than one signature is required, see below*.

*Total of _____ forms are submitted.

This collection of information is required by 37 CFR 41.31. The information is required to obtain or retain a benefit by the public which is to file (and by the USPTO to process) an application. Confidentiality is governed by 35 U.S.C. 122 and 37 CFR 1.11, 1.14 and 41.6. This collection is estimated to take 12 minutes to complete, including gathering, preparing, and submitting the completed application form to the USPTO. Time will vary depending upon the individual case. Any comments on the amount of time you require to complete this form and/or suggestions for reducing this burden, should be sent to the Chief Information Officer, U.S. Patent and Trademark Office, U.S. Department of Commerce, P.O. Box 1450, Alexandria, VA 22313-1450. DO NOT SEND FEES OR COMPLETED FORMS TO THIS ADDRESS. SEND TO: Commissioner for Patents, P.O. Box 1450, Alexandria, VA 22313-1450.

If you need assistance in completing the form, call 1-800-PTO-9199 and select option 2.

IN THE UNITED STATES PATENT AND TRADEMARK OFFICE

Patentee : Scott Blair)
 Patent No. : 6,700,602 – Issued 03/02/2004)
 Control No. : 90/011,861)
 Filed : August 16, 2011)
 For : **SUBWAY TV MEDIA SYSTEM**)
 Examiner : Stephen Ralis)
 Group Art Unit: 3992)



27299

PATENT TRADEMARK OFFICE

CERTIFICATE OF ELECTRONIC (EFS-WEB) TRANSMISSION

I hereby certify that this correspondence is being transmitted via the Office electronic filing system in accordance with 37 C.F.R. § 1.8(a)(i)(C) from the Pacific Time Zone of the United States on the local date shown below.

January 18, 2013

(Date)

Peter J. Gutierrez III

Peter J. Gutierrez III, Reg. No. 56,732

PETITION FOR REVIVAL OF AN APPLICATION FOR EX PARTE REEXAMINATION UNDER 37 C.F.R. § 1.137(b)

Mail Stop *Ex Parte Reexam*
Central Reexamination Unit
Commissioner For Patents
P.O. Box 1450
Alexandria, VA 22313-1450

Dear Sir:

The above-identified application for ex parte reexamination became abandoned for failure to file a timely and proper reply to a Final Office Action from the United States Patent and Trademark Office dated April 25, 2012. The Patent Office issued an Advisory Action dated January 16, 2013, terminating the aforementioned ex parte reexamination.

Applicant respectfully submits that pursuant to MPEP §711.03(c) citing *H.R. Rep. No. 542, 97th Cong., 2d Sess. 6-7 (1982)* that the abandonment of the application was not the result of a deliberately chosen course of action on the part of the Assignee. The following outlines the evidence applicable to this matter:

Control No. : 90/011,861
Filed : August 16, 2011

1. On April 25, 2012, Examiner Stephen Ralis of the USPTO issued a Final Office Action dated April 25, 2012 to Gazdzinski & Associates, PC ("GAPC"), Attorneys for Patentee Scott Blair.

2. On June 25, 2012, GAPC timely filed a Response to the Final Office Action dated April 25, 2012.

3. On January 16, 2013, an Advisory Action was issued to GAPC with respect to the above ex parte reexamination. The Advisory Action was issued well after the six month time period set forth in the Final Office Action, and thus terminated the aforementioned ex parte reexamination.

4. Applicant submits that the entire delay in filing the Notice of Appeal to the April 25, 2012 Final Office Action from the due date for this Notice of Appeal (i.e. October 25, 2012) until the filing of a grantable petition pursuant to 37 C.F.R. §1.137 was unintentional.

Applicant hereby petitions for revival of this application under 37 C.F.R. §1.137(b).

The petition fee for revival of an unintentionally abandoned application for a small entity is \$945.00 in accordance with 37 C.F.R. § 1.17(m). The Commissioner is hereby authorized to charge the petition fee amount to Deposit Account No. 501423.

I hereby declare that all statements made herein of my own knowledge are true and that all statements made on information and belief are believed to be true; and further that these statements were made with the knowledge that willful false statements and the like so made are punishable by fine or imprisonment, or both, under Section 1001 of Title 18 of the United States Code and that such willful, false statements may jeopardize the validity of the application or any patent issued thereon.

Respectfully submitted,

GAZDZINSKI & ASSOCIATES, PC

Dated: January 18, 2013

By: 
Peter J. Gutierrez, III
Reg. No. 56,732
16644 West Bernardo Drive, Suite 201
San Diego, CA 92127
Telephone No.: (858) 675-1670
Facsimile No.: (858) 675-1674

IN THE UNITED STATES PATENT AND TRADEMARK OFFICE

Applicant : Scott Blair)
 App. No. : 90/011,861)
 Filed : August 16, 2011)
 For : **SUBWAY TV MEDIA SYSTEM**)
 Examiner : Ralis, Stephen J.)
 Group Art Unit: 3992)



27299

PATENT TRADEMARK OFFICE

CERTIFICATE OF ELECTRONIC (EFS-WEB) TRANSMISSION

I hereby certify that this correspondence is being transmitted via the Office electronic filing system in accordance with 37 C.F.R. § 1.8(a)(1)(C) from the Pacific Time Zone of the United States on the local date shown below

March 18, 2013
(Date)

Peter J. Gutierrez, III, Reg. No. 56,732

TRANSMITTAL LETTER

**MAIL STOP APPEAL BRIEF-PATENTS
 COMMISSIONER FOR PATENTS
 P.O. BOX 1450
 ALEXANDRIA, VA 22313-1450**

Sir:

Transmitted herewith in the above-entitled application are the following:

- (X) Amended Appeal Brief Pursuant to 37 CFR 41.37, with attachments (26 Pages).
- (X) The Commissioner is hereby authorized to charge any deficiency in fees owed under 37 CFR 1.16 and 1.17 which may be required to Deposit Account No. 501423.

Respectfully submitted,

GAZDZINSKI & ASSOCIATES, PC

Dated: March 18, 2013

By:
 Peter J. Gutierrez, III
 Registration No. 56,732
 16644 West Bernardo Drive, Suite 201
 San Diego, CA 92127
 Telephone No.: (858) 675-1670
 Facsimile No.: (858) 675-1674

Electronic Acknowledgement Receipt

EFS ID:	15292120
Application Number:	90011861
International Application Number:	
Confirmation Number:	3736
Title of Invention:	SUBWAY TV MEDIA SYSTEM
First Named Inventor/Applicant Name:	6700602
Customer Number:	27299
Filer:	Robert F. Gazdzinski/Rebecca Beach
Filer Authorized By:	Robert F. Gazdzinski
Attorney Docket Number:	BLAIR.001A
Receipt Date:	18-MAR-2013
Filing Date:	16-AUG-2011
Time Stamp:	20:20:59
Application Type:	Reexam (Patent Owner)

Payment information:

Submitted with Payment	no
------------------------	----

File Listing:

Document Number	Document Description	File Name	File Size(Bytes)/ Message Digest	Multi Part /.zip	Pages (if appl.)
1	Appeal Brief Filed	Appeal_Brief.pdf	1239291 <small>ee99388b4523c9dcd6d2dfa42b81394b9c265b57</small>	no	26

Warnings:

Information:

2	Transmittal Letter	Transmittal.pdf	26470 6e8243db3f54b610117d3e5ddc85c8c992379a30	no	1
---	--------------------	-----------------	---	----	---

Warnings:

Information:

Total Files Size (in bytes):	1265761
-------------------------------------	---------

This Acknowledgement Receipt evidences receipt on the noted date by the USPTO of the indicated documents, characterized by the applicant, and including page counts, where applicable. It serves as evidence of receipt similar to a Post Card, as described in MPEP 503.

New Applications Under 35 U.S.C. 111

If a new application is being filed and the application includes the necessary components for a filing date (see 37 CFR 1.53(b)-(d) and MPEP 506), a Filing Receipt (37 CFR 1.54) will be issued in due course and the date shown on this Acknowledgement Receipt will establish the filing date of the application.

National Stage of an International Application under 35 U.S.C. 371

If a timely submission to enter the national stage of an international application is compliant with the conditions of 35 U.S.C. 371 and other applicable requirements a Form PCT/DO/EO/903 indicating acceptance of the application as a national stage submission under 35 U.S.C. 371 will be issued in addition to the Filing Receipt, in due course.

New International Application Filed with the USPTO as a Receiving Office

If a new international application is being filed and the international application includes the necessary components for an international filing date (see PCT Article 11 and MPEP 1810), a Notification of the International Application Number and of the International Filing Date (Form PCT/RO/105) will be issued in due course, subject to prescriptions concerning national security, and the date shown on this Acknowledgement Receipt will establish the international filing date of the application.



UNITED STATES PATENT AND TRADEMARK OFFICE

UNITED STATES DEPARTMENT OF COMMERCE
United States Patent and Trademark Office
Address: COMMISSIONER FOR PATENTS
P.O. Box 1450
Alexandria, Virginia 22313-1450
www.uspto.gov

APPLICATION NO.	FILING DATE	FIRST NAMED INVENTOR	ATTORNEY DOCKET NO.	CONFIRMATION NO.
90/011,861	08/16/2011	6700602	BLAIR.001A	3736
27299 7590 06/24/2013 GAZDZINSKI & ASSOCIATES, PC 16644 WEST BERNARDO DRIVE SUITE 201 SAN DIEGO, CA 92127			EXAMINER RALIS, STEPHEN J	
			ART UNIT	PAPER NUMBER
			3992	
			MAIL DATE	DELIVERY MODE
			06/24/2013	PAPER

Please find below and/or attached an Office communication concerning this application or proceeding.

The time period for reply, if any, is set in the attached communication.



Gadzinski & Associates, PC
16644 West Bernardo Drive
Suite 201
San Diego, CA 92127

(For Patent Owner)

MAILED

JUN 24 2013

In re Scott Blair
Ex Parte Reexamination Proceeding
Control No. 90/011,861
Filed: August 16, 2011
For: U.S. Patent No. 6,700,602

:
: **DECISION GRANTING**
: **PETITION UNDER**
: **37 CFR 1.137(b)**
:

CENTRAL REEXAMINATION UNIT

This is a decision on the January 18, 2013 patent owner petition under 37 CFR 1.137(b) to accept an unintentionally delayed response to final Office action and revive the present terminated reexamination¹ ("the January 18, 2013 patent owner petition to revive").

The January 18, 2013 patent owner petition to revive is before the Office of Patent Legal Administration (OPLA) for consideration.

The January 18, 2013 patent owner petition to revive is **granted**.

STATUTES, REGULATIONS, AND PATENT EXAMINING PROCEDURES

35 U.S.C. 41(a)(7) provides, in pertinent part:

REVIVAL FEES. — On filing each petition ... for an unintentionally delayed response by the patent owner in any reexamination proceeding ...

¹ Although a Notice of Intent to Issue *Ex Parte* Reexamination Certificate (NIRC) has not been mailed to set forth the termination of the prosecution in this instance, the prosecution was "terminated" within the meaning of 37 CFR 1.550(d) for failure of the patent owner to timely file a proper response, within the meaning of 37 CFR 1.113, to the final Office action of April 25, 2012.

35 U.S.C. 133 provides:

Upon failure of the applicant to prosecute the application within six months after any action therein, of which notice has been given or mailed to the applicant, or within such shorter time, not less than thirty days, as fixed by the Director in such action, the application shall be regarded as abandoned by the parties thereto, unless it be shown to the satisfaction of the Director that such delay was unavoidable.

35 U.S.C. 305 provides, in pertinent part:

After the times for filing the statement and reply provided for by section 304 of this title have expired, reexamination will be conducted according to the procedures established for initial examination under the provisions of sections 132 and 133 of this title.

37 CFR 1.113 provides, in pertinent part:

(a) On the second or any subsequent examination or consideration by the examiner the rejection or other action may be made final, whereupon ... for *ex parte* reexaminations filed under § 1.510, patent owner's reply is limited to appeal in the case of rejection of any claim (§ 41.31 of this title), or to amendment as specified in § 1.114 or § 1.116.

*
*

(c) Reply to a final rejection or action must include cancellation of, or appeal from the rejection of, each rejected claim. If any claim stands allowed, the reply to a final rejection or action must comply with any requirements or objections as to form.

37 CFR 1.137 provides, in pertinent part:

(b) *Unintentional*. If the delay in reply by ... patent owner was unintentional, a petition may be filed pursuant to this paragraph to revive ... a reexamination prosecution terminated under §§ 1.550(d) or 1.957(b) or limited under § 1.957(c) A grantable petition pursuant to this paragraph must be accompanied by:

- (1) The reply required to the outstanding Office action or notice, unless previously filed;
- (2) The petition fee as set forth in § 1.17(m);
- (3) A statement that the entire delay in filing the required reply from the due date for the reply until the filing of a grantable petition pursuant to this paragraph was unintentional. The Director may require additional information where there is a question whether the delay was unintentional

*
*

(d) *Terminal disclaimer*.

*
*

(3) The provisions of paragraph (d)(1) of this section do not apply to ... reexamination proceedings.

37 CFR 1.550 provides, in pertinent part:

(d) If the patent owner fails to file a timely and appropriate response to any Office action or any written statement of an interview required under § 1.560(b), the prosecution in the *ex parte* reexamination proceeding will be a terminated prosecution, and the Director will proceed to issue and publish a certificate concluding the reexamination proceeding under § 1.570 in accordance with the last action of the Office.

(e) If a response by the patent owner is not timely filed in the Office,

*

*

(2) The response may nevertheless be accepted if the delay was unintentional; a petition to accept an unintentionally delayed response must be filed in compliance with § 1.137(b).

MPEP 711.03(c)(II)(A)(2)(b) provides, in pertinent part:

A reply under 37 CFR 1.113 to a final action must include ... cancellation of, or appeal from the rejection of, each claim so rejected. Accordingly, ... the reply required for consideration of a petition to revive must be:

(A) a Notice of Appeal and appeal fee; [or]

(B) an amendment under 37 CFR 1.116 that cancels all the rejected claims or otherwise prima facie places the application in condition for allowance;

*

*

When a notice of appeal is the reply filed pursuant to 37 CFR 1.137(a)(1) or 1.137(b)(1), the time period under 37 CFR 41.37 for filing the appeal brief will be set by the Director of the USPTO in the decision granting the petition.

MPEP 2268 provides, in pertinent part:

II. PETITION BASED ON UNINTENTIONAL DELAY

The unintentional delay fee provisions of 35 U.S.C. 41(a)(7) are imported into, and are applicable to, all *ex parte* reexamination proceedings by section 4605 of the American Inventors Protection Act of 1999. The unintentional delay provisions of 35 U.S.C. 41(a)(7) became effective in reexamination proceedings on November 29, 2000. Accordingly, the Office will consider, in appropriate circumstances, a petition showing unintentional delay under 37 CFR 1.137(b) where untimely papers are filed subsequent to the order for reexamination. Any such petition must provide a verified statement that the delay was unintentional, a proposed response to continue prosecution (unless it has been previously filed), and the petition fee set forth in 37 CFR 1.17(m).

*

*

IV. FURTHER DISCUSSION OF THE PETITION REQUIREMENTS

See also MPEP § 711.03(c), subsection III, for a detailed discussion of the requirements of petitions filed under 37 CFR 1.137(a) and (b).

DECISION

The Petition Under 37 CFR 1.137(b) is Granted

A grantable petition under 37 CFR 1.137(b) for a reexamination proceeding must be accompanied by: (1) a response to the outstanding Office action; (2) the petition fee set forth in 37 CFR 1.17(m); and (3) a proper statement under 37 CFR 1.137(b)(3) that the entire delay in filing the required response from the due date of the response to the filing of a grantable petition was unintentional.

Regarding item (1), the instant reexamination proceeding was terminated due to the failure to timely submit an appropriate response to the April 25, 2012 final Office action pursuant to 37 CFR 1.550(b). In a reexamination proceeding terminated for failure to reply to a final Office action, the reply required for consideration of a petition to revive must be (i) an amendment under 37 CFR 1.116 that cancels all the rejected claims or otherwise *prima facie* places the proceeding in condition for issuance of a reexamination certificate by making all pending claims patentable or (ii) a Notice of Appeal and appeal fee.² Patent owner submitted a Notice of Appeal and paid the corresponding fee of \$315.00 on January 18, 2013, thereby satisfying item (1).

The petition fee under 37 CFR 1.17(m) required by 37 CFR 1.137(b)(2) and a proper statement under 37 CFR 1.137(b)(3) were submitted as part of the January 18, 2013 patent owner petition to revive, which satisfy items (2) and (3), respectively.

The present proceeding is a reexamination proceeding; thus, the petition does not require a terminal disclaimer.³

Accordingly, the January 18, 2013 patent owner petition to revive is **granted**.

CONCLUSION

1. The January 18, 2013 patent owner petition to revive under 37 CFR 1.137(b) is **granted**.

² See: MPEP 2268(IV) and MPEP 711.03(c)(II)(A)(2)(b).

³ See: 37 CFR 1.137(d)(3).

2. Art Unit 3992 of the Central Reexamination Unit will process the January 18, 2013 Notice of Appeal and the March 18, 2013 Appeal Brief in the 90/011,861 reexamination proceeding.
3. Any inquiry concerning the examination of the reexamination proceeding should be directed to the primary examiner, Stephen Ralis, of CRU Art Unit 3992, at (571) 272-6227.
4. Any inquiry concerning this decision should be directed to the undersigned at (571) 272-7728.

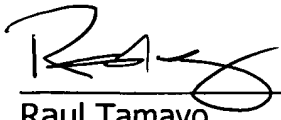

Raul Tamayo
Senior Legal Advisor
Office of Patent Legal Administration

06/14/2013



UNITED STATES PATENT AND TRADEMARK OFFICE

UNITED STATES DEPARTMENT OF COMMERCE
United States Patent and Trademark Office
Address: COMMISSIONER FOR PATENTS
P.O. Box 1450
Alexandria, Virginia 22313-1450
www.uspto.gov

APPLICATION NO.	FILING DATE	FIRST NAMED INVENTOR	ATTORNEY DOCKET NO.	CONFIRMATION NO.
90/011,861	08/16/2011	6700602	BLAIR.001A	3736
27299	7590	07/10/2013	EXAMINER	
GAZDZINSKI & ASSOCIATES, PC 16644 WEST BERNARDO DRIVE SUITE 201 SAN DIEGO, CA 92127			RALIS, STEPHEN J	
			ART UNIT	PAPER NUMBER
			3992	
			MAIL DATE	DELIVERY MODE
			07/10/2013	PAPER

Please find below and/or attached an Office communication concerning this application or proceeding.

The time period for reply, if any, is set in the attached communication.

Art Unit: 3992



UNITED STATES PATENT AND TRADEMARK OFFICE

Commissioner for Patents
United States Patent and Trademark Office
P.O. Box 1450
Alexandria, VA 22313-1450
www.uspto.gov

**BEFORE THE BOARD OF PATENT APPEALS
AND INTERFERENCES**

Application Number: 90/011,861
Filing Date: 16 August 2011
Appellant(s): 6,700,602

Peter J. Gutierrez, III
For Appellant

EXAMINER'S ANSWER

This is in response to the appeal brief filed 18 March 2013.

(1) Grounds of Rejection to be Reviewed on Appeal

Every ground of rejection set forth in the Office action dated 25 April 2012 from which the appeal is taken is being maintained by the examiner except for the grounds of rejection (if any) listed under the subheading "WITHDRAWN REJECTIONS." New grounds of rejection (if any) are provided under the subheading "NEW GROUNDS OF REJECTION."

The following ground(s) of rejection are applicable to the appealed claims.

Issue 1

Claim 1 is rejected under 35 U.S.C. 102(b) as being anticipated by Minesaki (Japanese. Publication No. JP 63-125984 of Japanese Application No. JP 61-272668).

With respect to the limitations of claim 1, Minesaki discloses a subway car (train cars; page 588, lines 6-10; page 590, lines 18-19) for mass transportation including longitudinal opposed sidewalls (**9**), a ceiling (top portion in Figure 2) adjoining the sidewalls (**9**), a video display system (control part G/information communication display part **J** combination) comprising a plurality of video display monitors (see references to **J** on each side of sidewall **9** and ceiling interface in Figure 2) each having a video screen (**display**), and a video signal source unit (control part **G**) operatively connected to the monitors (see references to **J** on each side of sidewall **9** and ceiling interface in Figure 2), the monitors (see references to **J** on each side of sidewall **9** and ceiling interface in Figure 2) being spaced along the length of the car on opposed sides thereof (in the middle of the length of each sidewall opposite each other; see Figure 2), each of the

Art Unit: 3992

monitors being mounted at the junction of the sidewall and ceiling (see Figure 2), with the screen (display) of the monitor (see one of references to J on each side of sidewall 9 and ceiling interface in Figure 2) substantially flushed with the adjacent wall surface structure of the car (see Figure 2), and directed obliquely downwardly toward the car seats (top portion of Information communication part J directed obliquely downwardly toward the car seats; see Figure 2) , so that each video screen (display) is readily visible to passengers in the subway car (train cars; page 588, lines 6-10; page 590, lines 18-19).

With respect to the limitation of claim 1 and “the screen of the monitor substantially flushed with the adjacent wall surface structure of the car”, the term “substantially” is often used in conjunction with another term to describe a particular characteristic of the claimed invention. It is a broad term. (See MPEP 2173.05). Minesaki explicitly discloses the screen (display) of the monitor (see one of references to J on each side of sidewall 9 and ceiling interface in Figure 2) being substantially flushed with the adjacent wall surface structure of the car (see Figure 2) given its broadest reasonable interpretation of “substantially flushed” in light of the Blair Patent disclosure (column 5, line 35 – column 6, line 7; see Figures 4A-7). Therefore, Minesaki fully meets “the screen of the monitor substantially flushed with the adjacent wall surface structure of the car” given its broadest reasonable interpretation.

Issue 2

Claim 1 is rejected under 35 U.S.C. 102(b) as being anticipated by Amano et al. (Japanese. Publication No. JP 02-23985 A).

Amano et al. discloses a subway car (train cars; page 651, column 2, lines 5-10, 28-33; page 653, column 1, lines 43-45; see Figures 4-6) for mass transportation including longitudinal opposed sidewalls (see Figures 4-6), a ceiling (see Figures 4-6) adjoining the sidewalls (see Figures 4-6), a video display system (see Figure 2) comprising a plurality of video display monitors (**8; 8a-8n**; see Figures 2, 4-6) each having a video screen (**display**), and a video signal source unit (display information signal transmitter) operatively connected to the monitors (**8; 8a-8n**; see Figures 2, 4-6), the monitors (**8; 8a-8n**; see Figures 2, 4-6) being spaced along the length of the car on opposed sides thereof (in the middle of the length of each sidewall opposite each other; see Figures 4-6), each of the monitors being mounted at the junction of the sidewall and ceiling (see Figures 4-6), with the screen (**display**) of the monitor (**8; 8a-8n**; see Figures 2, 4-6) substantially flushed with the adjacent wall surface structure of the car (see Figure 4-6), and directed obliquely downwardly toward the car seats (see Figures 4-6), so that each video screen (**display**) is readily visible to passengers in the subway car (train cars; page 651, column 2, lines 5-10, 28-33; page 653, column 1, lines 43-45; see Figures 4-6).

With respect to the limitation of “the screen of the monitor substantially flushed with the adjacent wall surface structure of the car”, the term “substantially” is often used in conjunction with another term to describe a particular characteristic of the claimed invention. It is a broad term. (See MPEP 2173.05). Minesaki explicitly discloses the

Art Unit: 3992

screen (display) of the monitor (**8; 8a-8n**; see Figures 2, 4-6) substantially flushed with the adjacent wall surface structure of the car (see Figures 4-6) given its broadest reasonable interpretation of "substantially flushed" in light of the Blair Patent disclosure (column 5, line 35 – column 6, line 7; see Figures 4A-7). Therefore, Amano et al. fully meets "the screen of the monitor substantially flushed with the adjacent wall surface structure of the car" given its broadest reasonable interpretation.

Issue 3

Claim 1 is rejected under 35 U.S.C. 103(a) as being unpatentable over Maekawa et al. (Japanese. Publication No. JP 04-160991 A) in view of Amano et al. (Japanese. Publication No. JP 02-23985 A).

Maekawa et al. discloses a subway car (car body of an electric train; page 738, column 2; see Figures 1, 2) for mass transportation including longitudinal opposed sidewalls (see Figures 1, 2), a ceiling (see Figures 1, 2) adjoining the sidewalls (see Figures 1, 2), a video display system (see Figure 1) comprising a plurality of video display monitors (**101-124**; page 738, column 2; see Figures 1, 2) each having a video screen (display), and a video signal source unit (see Figure 1) operatively connected to the monitors (**101-124**; page 738, column 2; see Figures 1, 2), the monitors (**101-124**; page 738, column 2; see Figures 1, 2) being spaced along the length of the car on opposed sides thereof (see Figures 1, 2), with the screen (**display**) of the monitor (**101-124**; page 738, column 2; see Figures 1, 2) substantially flushed with the adjacent wall surface structure of the car (low profile; page 738; see Figure 2), so that each video

Art Unit: 3992

screen (display) is readily visible to passengers in the subway car (car body of an electric train; page 738, column 2; see Figures 1, 2).

With respect to the limitation of “the screen of the monitor substantially flushed/blended with the adjacent wall surface structure of the car”, the term “substantially” is often used in conjunction with another term to describe a particular characteristic of the claimed invention. It is a broad term. (See MPEP 2173.05). Maekawa et al. explicitly discloses the screen (display) of the monitor being low profile, (101-124; page 738, column 2; see Figures 1, 2) substantially flushed with the adjacent wall surface structure of the car (see Figure 2) given its broadest reasonable interpretation of “substantially flushed” in light of the Blair Patent disclosure (column 5, line 35 – column 6, line 7; see Figures 4A-7). Therefore, Maekawa et al. et al. fully meets “the screen of the monitor substantially flushed/blended with the adjacent wall surface structure of the car” given its broadest reasonable interpretation.

Maekawa et al. discloses all of the limitations of the claimed invention, as previously set forth, except for specifically calling for each of the monitors being mounted at the junction of the sidewall and ceiling and directed obliquely downwardly toward the car seats.

However, each of the monitors being mounted at the junction of the sidewall and ceiling and directed obliquely downwardly toward the car seats is known in the art. Amano et al., for example, teaches each of the monitors being mounted at the junction of the sidewall and ceiling (see Figures 4-6) and directed obliquely downwardly toward the car seats (see Figures 4-6). Amano et al. further teaches such a configuration

Art Unit: 3992

presents a means to provide the offering place for information in transportation equipment being used more effectively and sharpness being obtained, thereby increasing the information offering ability to passengers (English translation Abstract). It would have been obvious to one of ordinary skill in the art at the time of the invention was made to modify the mounting and screen direction orientation of the monitors of Maekawa et al. with each of the monitors being mounted at the junction of the sidewall and ceiling and directed obliquely downwardly toward the car seats of Amano et al. in order to present a means to provide the offering place for information in transportation equipment being used more effectively and sharpness being obtained, thereby increasing the information offering ability to passengers.

To the degree it can be argued that “Minesaki”, “Amano et al.”, and/or “Maekawa et al.” and/or “ do not disclose “the screen of the monitor substantially flushed/blended or flushed with the adjacent wall surface structure of the car”; and “the video display monitor being substantially contiguous with an exterior surface of said transitional segment” given their broadest reasonable interpretation, the additional rejections are provided as set forth below:

Issue 5

Claim 1 is rejected under 35 U.S.C. 103(a) as being unpatentable over Minesaki (Japanese. Publication No. JP 63-125984 of Japanese Application No. JP 61-272668) in view of Moore et al. (U.S. Patent No. 3,480,727).

Art Unit: 3992

With respect to the limitations of claim 1, Minesaki discloses a subway car (train cars; page 588, lines 6-10; page 590, lines 18-19) for mass transportation including longitudinal opposed sidewalls (9), a ceiling (top portion in Figure 2) adjoining the sidewalls (9), a video display system (control part **G**/information communication display part **J** combination) comprising a plurality of video display monitors (see references to **J** on each side of sidewall 9 and ceiling interface in Figure 2) each having a video screen (**display**), and a video signal source unit (control part **G**) operatively connected to the monitors (see references to **J** on each side of sidewall 9 and ceiling interface in Figure 2), the monitors (see references to **J** on each side of sidewall 9 and ceiling interface in Figure 2) being spaced along the length of the car on opposed sides thereof (in the middle of the length of each sidewall opposite each other; see Figure 2), each of the monitors being mounted at the junction of the sidewall and ceiling (see Figure 2), with the screen (**display**) of the monitor being projecting slightly beyond the adjacent wall surface structure of the car (see Figure 2) and directed obliquely downwardly toward the car seats (top portion of Information communication part **J** directed obliquely downwardly toward the car seats; see Figure 2) , so that each video screen (**display**) is readily visible to passengers in the subway car (train cars; page 588, lines 6-10; page 590, lines 18-19).

Minesaki discloses all of the limitations of the claimed invention, as previously set forth, except for specifically calling for the screen of the monitor being substantially flushed with the adjacent wall surface structure instead of the monitor being projecting slightly beyond the adjacent wall surface structure.

Art Unit: 3992

However, a screen of the monitor being substantially flushed with the adjacent wall surface structure is known in the art. Moore et al., for example, teach a screen of the monitor being substantially flushed with the adjacent wall surface structure as being an equivalent structure in the art (column 7, lines 41-44). Moore et al. further teaches such a configuration provides a means to compensate for wall thickness or, the availability of space beyond the surface of the wall (column 7, lines 44-47). It would have been obvious to one of ordinary skill in the art at the time of the invention was made to modify the monitor being projecting slightly beyond the adjacent wall surface structure of the car of Minesaki with the screen of the monitor being substantially flushed with the adjacent wall surface structure of Moore et al. in order to provide a means to compensate for wall thickness or, the availability of space beyond the surface of the wall. In addition, because these two monitor/wall configurations were art recognized equivalents at the time the invention was made, one of ordinary skill in the art would have found it obvious to substitute a screen of the monitor being substantially flushed with the adjacent wall surface structure for a monitor being projecting slightly beyond the adjacent wall surface structure.

Similarly, the examiner asserts that applying a known technique to a known device ready for improvement would yield predictable results. That is, it would have been recognized by one of ordinary skill in the art that applying the known technique taught by Moore et al. to the subway car of Minesaki would have yielded predictable results and resulted in an improved system, namely, a screen of the monitor being substantially flushed with the adjacent wall surface structure for a monitor being

Art Unit: 3992

projecting slightly beyond the adjacent wall surface structure in Minesaki to provide a means to compensate for wall thickness or, the availability of space beyond the surface of the wall.

Moreover, the examiner asserts that simple substitution of one known element for another would obtain predictable results. That is, the substitution of one known element (a screen of the monitor being substantially flushed with the adjacent wall surface structure as shown in Moore et al.) for another (a monitor being projecting slightly beyond the adjacent wall surface structure as shown in Moore et al. and Minesaki) would have been obvious to one of ordinary skill in the art at the time of the invention since the substitution of a screen of the monitor being substantially flushed with the adjacent wall surface structure in Minesaki would have yielded predictable results, namely, providing a screen of the monitor being substantially flushed with the adjacent wall surface structure in Minesaki to provide a means to compensate for wall thickness or, the availability of space beyond the surface of the wall.

Furthermore, the examiner asserts use of known technique to improve similar devices in the same way is obvious to one of ordinary skill in the art. That is, the manner of enhancing a particular device (providing a screen of the monitor being substantially flushed with the adjacent wall surface structure) was made part of the ordinary capabilities of one skilled in the art based upon the teaching of such improvement in Moore et al. Accordingly, one of ordinary skill in the art would have been capable of applying this known "improvement" technique in the same manner to the prior art subway car of Minesaki and the results would have been predictable to one of ordinary

Art Unit: 3992

skill in the art, namely, one skilled in the art would have readily recognized that providing a screen of the monitor being substantially flushed with the adjacent wall surface structure in Minesaki would positively provide a means to compensate for wall thickness or, the availability of space beyond the surface of the wall.

Issue 6

Claim 1 is rejected under 35 U.S.C. 103(a) as being unpatentable over Amano et al. (Japanese. Publication No. JP 02-23985 A) in view of Moore et al. (U.S. Patent No. 3,480,727).

With respect to the limitations of claim 1, Amano et al. discloses a subway car (train cars; page 651, column 2, lines 5-10, 28-33; page 653, column 1, lines 43-45; see Figures 4-6) for mass transportation including longitudinal opposed sidewalls (see Figures 4-6), a ceiling (see Figures 4-6) adjoining the sidewalls (see Figures 4-6), a video display system (see Figure 2) comprising a plurality of video display monitors (8; 8a-8n; see Figures 2, 4-6) each having a video screen (display), and a video signal source unit (display information signal transmitter) operatively connected to the monitors (8; 8a-8n; see Figures 2, 4-6), the monitors (8; 8a-8n; see Figures 2, 4-6) being spaced along the length of the car on opposed sides thereof (in the middle of the length of each sidewall opposite each other; see Figures 4-6), each of the monitors being mounted at the junction of the sidewall and ceiling (see Figures 4-6), with the screen (display) of the monitor being projecting slightly beyond the adjacent wall surface structure of the car (see Figures 4-6) and directed obliquely downwardly toward the car seats (see Figures

Art Unit: 3992

4-6) , so that each video screen (display) is readily visible to passengers in the subway car (train cars; page 651, column 2, lines 5-10, 28-33; page 653, column 1, lines 43-45; see Figures 4-6).

Amano et al. discloses all of the limitations of the claimed invention, as previously set forth, except for specifically calling for the screen of the monitor being substantially flushed with the adjacent wall surface structure instead of the monitor being projecting slightly beyond the adjacent wall surface structure.

However, a screen of the monitor being substantially flushed with the adjacent wall surface structure is known in the art. Moore et al., for example, teach a screen of the monitor being substantially flushed with the adjacent wall surface structure as being an equivalent structure in the art (column 7, lines 41-44). Moore et al. further teaches such a configuration provides a means to compensate for wall thickness or, the availability of space beyond the surface of the wall (column 7, lines 44-47). It would have been obvious to one of ordinary skill in the art at the time of the invention was made to modify the monitor being projecting slightly beyond the adjacent wall surface structure of the car of Amano et al. with the screen of the monitor being substantially flushed with the adjacent wall surface structure of Moore et al. in order to provide a means to compensate for wall thickness or, the availability of space beyond the surface of the wall. In addition, because these two monitor/wall configurations were art recognized equivalents at the time the invention was made, one of ordinary skill in the art would have found it obvious to substitute a screen of the monitor being substantially

Art Unit: 3992

flushed with the adjacent wall surface structure for a monitor being projecting slightly beyond the adjacent wall surface structure.

Similarly, the examiner asserts that applying a known technique to a known device ready for improvement would yield predictable results. That is, it would have been recognized by one of ordinary skill in the art that applying the known technique taught by Moore et al. to the subway car of Amano et al. would have yielded predictable results and resulted in an improved system, namely, a screen of the monitor being substantially flushed with the adjacent wall surface structure for a monitor being projecting slightly beyond the adjacent wall surface structure in Amano et al. to provide a means to compensate for wall thickness or, the availability of space beyond the surface of the wall.

Moreover, the examiner asserts that simple substitution of one known element for another would obtain predictable results. That is, the substitution of one known element (a screen of the monitor being substantially flushed with the adjacent wall surface structure as shown in Moore et al.) for another (a monitor being projecting slightly beyond the adjacent wall surface structure as shown in Moore et al. and Amano et al.) would have been obvious to one of ordinary skill in the art at the time of the invention since the substitution of a screen of the monitor being substantially flushed with the adjacent wall surface structure in Amano et al. would have yielded predictable results, namely, providing a screen of the monitor being substantially flushed with the adjacent wall surface structure in Amano et al. to provide a means to compensate for wall thickness or, the availability of space beyond the surface of the wall.

Furthermore, the examiner asserts use of known technique to improve similar devices in the same way is obvious to one of ordinary skill in the art. That is, the manner of enhancing a particular device (providing a screen of the monitor being substantially flushed with the adjacent wall surface structure) was made part of the ordinary capabilities of one skilled in the art based upon the teaching of such improvement in Moore et al. Accordingly, one of ordinary skill in the art would have been capable of applying this known "improvement" technique in the same manner to the prior art subway car of Amano et al. and the results would have been predictable to one of ordinary skill in the art, namely, one skilled in the art would have readily recognized that providing a screen of the monitor being substantially flushed with the adjacent wall surface structure in Amano et al. would positively provide a means to compensate for wall thickness or, the availability of space beyond the surface of the wall.

Issue 7

Claim 1 is rejected under 35 U.S.C. 103(a) as being unpatentable over Maekawa et al. (Japanese. Publication No. JP 04-160991 A) in view of Amano et al. (Japanese. Publication No. JP 02-23985 A) and Moore et al. (U.S. Patent No. 3,480,727).

With respect to the limitations of claim 1, Maekawa et al. discloses a subway car (car body of an electric train; page 738, column 2; see Figures 1, 2) for mass transportation including longitudinal opposed sidewalls (see Figures 1, 2), a ceiling (see Figures 1, 2) adjoining the sidewalls (see Figures 1, 2), a video display system (see Figure 1) comprising a plurality of video display monitors (101-124; page 738, column 2;

Art Unit: 3992

see Figures 1, 2) each having a video screen (display), and a video signal source unit (see Figure 1) operatively connected to the monitors (101-124; page 738, column 2; see Figures 1, 2), the monitors (101-124; page 738, column 2; see Figures 1, 2) being spaced along the length of the car on opposed sides thereof (see Figures 1, 2), so that each video screen (display) is readily visible to passengers in the subway car (car body of an electric train; page 738, column 2; see Figures 1, 2).

Maekawa et al. discloses all of the limitations of the claimed invention, as previously set forth, except for specifically calling for each of the monitors being mounted at the junction of the sidewall and ceiling and directed obliquely downwardly toward the car seats; and the screen of the monitor being substantially flushed with the adjacent wall surface structure instead of the monitor being projecting slightly beyond the adjacent wall surface structure.

However, each of the monitors being mounted at the junction of the sidewall and ceiling and directed obliquely downwardly toward the car seats is known in the art. Amano et al., for example, teaches each of the monitors being mounted at the junction of the sidewall and ceiling (see Figures 4-6) and directed obliquely downwardly toward the car seats (see Figures 4-6). Amano et al. further teaches such a configuration presents a means to provide the offering place for information in transportation equipment being used more effectively and sharpness being obtained, thereby increasing the information offering ability to passengers (English translation Abstract). It would have been obvious to one of ordinary skill in the art at the time of the invention was made to modify the mounting and screen direction orientation of the monitors of

Art Unit: 3992

Maekawa et al. with each of the monitors being mounted at the junction of the sidewall and ceiling and directed obliquely downwardly toward the car seats of Amano et al. in order to present a means to provide the offering place for information in transportation equipment being used more effectively and sharpness being obtained, thereby increasing the information offering ability to passengers.

Similarly, a screen of the monitor being substantially flushed with the adjacent wall surface structure is known in the art. Moore et al., for example, teach a screen of the monitor being substantially flushed with the adjacent wall surface structure as being an equivalent structure in the art (column 7, lines 41-44). Moore et al. further teaches such a configuration provides a means to compensate for wall thickness or, the availability of space beyond the surface of the wall (column 7, lines 44-47). It would have been obvious to one of ordinary skill in the art at the time of the invention was made to modify the monitor being projecting slightly beyond the adjacent wall surface structure of the car of Maekawa et al. with the screen of the monitor being substantially flushed with the adjacent wall surface structure of Moore et al. in order to provide a means to compensate for wall thickness or, the availability of space beyond the surface of the wall. Furthermore, because these two monitor/wall configurations were art recognized equivalents at the time the invention was made, one of ordinary skill in the art would have found it obvious to substitute a screen of the monitor being substantially flushed with the adjacent wall surface structure for a monitor being projecting slightly beyond the adjacent wall surface structure.

Similarly, the examiner asserts that applying a known technique to a known device ready for improvement would yield predictable results. That is, it would have been recognized by one of ordinary skill in the art that applying the known technique taught by Moore et al. to the subway car of Maekawa et al. would have yielded predictable results and resulted in an improved system, namely, a screen of the monitor being substantially flushed with the adjacent wall surface structure for a monitor being projecting slightly beyond the adjacent wall surface structure in Maekawa et al. to provide a means to compensate for wall thickness or, the availability of space beyond the surface of the wall.

Moreover, the examiner asserts that simple substitution of one known element for another would obtain predictable results. That is, the substitution of one known element (a screen of the monitor being substantially flushed with the adjacent wall surface structure as shown in Moore et al.) for another (a monitor being projecting slightly beyond the adjacent wall surface structure as shown in Moore et al. and Maekawa et al.) would have been obvious to one of ordinary skill in the art at the time of the invention since the substitution of a screen of the monitor being substantially flushed with the adjacent wall surface structure in Maekawa et al. would have yielded predictable results, namely, providing a screen of the monitor being substantially flushed with the adjacent wall surface structure in Maekawa et al. to provide a means to compensate for wall thickness or, the availability of space beyond the surface of the wall.

Furthermore, the examiner asserts use of known technique to improve similar devices in the same way is obvious to one of ordinary skill in the art. That is, the manner of enhancing a particular device (providing a screen of the monitor being substantially flushed with the adjacent wall surface structure) was made part of the ordinary capabilities of one skilled in the art based upon the teaching of such improvement in Moore et al. Accordingly, one of ordinary skill in the art would have been capable of applying this known "improvement" technique in the same manner to the prior art subway car of Maekawa et al. and the results would have been predictable to one of ordinary skill in the art, namely, one skilled in the art would have readily recognized that providing a screen of the monitor being substantially flushed with the adjacent wall surface structure in Maekawa et al. would positively provide a means to compensate for wall thickness or, the availability of space beyond the surface of the wall.

Issue 8

Claim 1 is rejected under 35 U.S.C. 103(a) as being unpatentable over Shinagawa et al. (Japanese. Publication No. JP 04-160991 A) in view of Amano et al. (Japanese. Publication No. JP 02-23985 A) and Moore et al. (U.S. Patent No. 3,480,727).

With respect to the limitations of claim 1, Shinagawa et al. discloses a subway car (car of a train; page 619, column 1; see Figure 4) for mass transportation including longitudinal opposed sidewalls (see Figure 4), a ceiling (see Figure 4) adjoining the sidewalls (see Figure 4), a video display system (see Figure 1) comprising a plurality of

Art Unit: 3992

video display monitors (**21-2n**; page 621, column 1; see Figures 1, 4) each having a video screen (**display**), and a video signal source unit (see Figure 1) operatively connected to the monitors (**21-2n**; page 621, column 1; see Figures 1, 4), the monitors (**21-2n**; page 621, column 1; see Figures 1, 4) being spaced along the length of the car on opposed sides thereof (page 621, column 1, paragraph 3; see Figures 1, 4), so that each video screen (**display**) is readily visible to passengers in the subway car (car of a train; page 619, column 1; see Figure 4).

Shinagawa et al. discloses all of the limitations of the claimed invention, as previously set forth, except for specifically calling for each of the monitors being mounted at the junction of the sidewall and ceiling and directed obliquely downwardly toward the car seats; and the screen of the monitor being substantially flushed with the adjacent wall surface structure instead of the monitor being projecting slightly beyond the adjacent wall surface structure.

However, each of the monitors being mounted at the junction of the sidewall and ceiling and directed obliquely downwardly toward the car seats is known in the art. Amano et al., for example, teaches each of the monitors being mounted at the junction of the sidewall and ceiling (see Figures 4-6) and directed obliquely downwardly toward the car seats (see Figures 4-6). Amano et al. further teaches such a configuration presents a means to provide the offering place for information in transportation equipment being used more effectively and sharpness being obtained, thereby increasing the information offering ability to passengers (English translation Abstract). It would have been obvious to one of ordinary skill in the art at the time of the invention

Art Unit: 3992

was made to modify the mounting and screen direction orientation of the monitors of Shinagawa et al. with each of the monitors being mounted at the junction of the sidewall and ceiling and directed obliquely downwardly toward the car seats of Amano et al. in order to present a means to provide the offering place for information in transportation equipment being used more effectively and sharpness being obtained, thereby increasing the information offering ability to passengers.

Similarly, a screen of the monitor being substantially flushed with the adjacent wall surface structure is known in the art. Moore et al. for example, teach a screen of the monitor being substantially flushed with the adjacent wall surface structure as being an equivalent structure in the art (column 7, lines 41-44). Moore et al. further teaches such a configuration provides a means to compensate for wall thickness or, the availability of space beyond the surface of the wall (column 7, lines 44-47). It would have been obvious to one of ordinary skill in the art at the time of the invention was made to modify the monitor being projecting slightly beyond the adjacent wall surface structure of the car of Shinagawa et al. with the screen of the monitor being substantially flushed with the adjacent wall surface structure of Moore et al. in order to provide a means to compensate for wall thickness or, the availability of space beyond the surface of the wall. Furthermore, because these two monitor/wall configurations were art recognized equivalents at the time the invention was made, one of ordinary skill in the art would have found it obvious to substitute a screen of the monitor being substantially flushed with the adjacent wall surface structure for a monitor being projecting slightly beyond the adjacent wall surface structure.

Art Unit: 3992

Similarly, the examiner asserts that applying a known technique to a known device ready for improvement would yield predictable results. That is, it would have been recognized by one of ordinary skill in the art that applying the known technique taught by Moore et al. to the subway car of Shinagawa et al. would have yielded predictable results and resulted in an improved system, namely, a screen of the monitor being substantially flushed with the adjacent wall surface structure for a monitor being projecting slightly beyond the adjacent wall surface structure in Shinagawa et al. to provide a means to compensate for wall thickness or, the availability of space beyond the surface of the wall.

Moreover, the examiner asserts that simple substitution of one known element for another would obtain predictable results. That is, the substitution of one known element (a screen of the monitor being substantially flushed with the adjacent wall surface structure as shown in Moore et al.) for another (a monitor being projecting slightly beyond the adjacent wall surface structure as shown in Moore et al. and Shinagawa et al.) would have been obvious to one of ordinary skill in the art at the time of the invention since the substitution of a screen of the monitor being substantially flushed with the adjacent wall surface structure in Shinagawa et al. would have yielded predictable results, namely, providing a screen of the monitor being substantially flushed with the adjacent wall surface structure in Shinagawa et al. to provide a means to compensate for wall thickness or, the availability of space beyond the surface of the wall.

Furthermore, the examiner asserts use of known technique to improve similar devices in the same way is obvious to one of ordinary skill in the art. That is, the manner of enhancing a particular device (providing a screen of the monitor being substantially flushed with the adjacent wall surface structure) was made part of the ordinary capabilities of one skilled in the art based upon the teaching of such improvement in Moore et al. Accordingly, one of ordinary skill in the art would have been capable of applying this known "improvement" technique in the same manner to the prior art subway car of Amano et al. and the results would have been predictable to one of ordinary skill in the art, namely, one skilled in the art would have readily recognized that providing a screen of the monitor being substantially flushed with the adjacent wall surface structure in Shinagawa et al. would positively provide a means to compensate for wall thickness or, the availability of space beyond the surface of the wall.

(2) Response to Argument

REMARKS

Owners Arguments

Issue 1: Rejection of Claim 1 under 35 under 35 U.S.C. 102 as Being Anticipated by Minesaki

With respect to Appellant's reply/argument that Minesaki fails to expressly or inherently describe "each of said monitor being mounted at the junction of the sidewall

Art Unit: 3992

and ceiling”, the examiner respectfully disagrees. As Appellant has noted, Minesaki discloses

This information transmission display part J may also be formed on the sidewall of the train car (Minesaki; page 590, right upper most column).

Minesaki further discloses such a configuration in the annotated Figure 2, as shown below

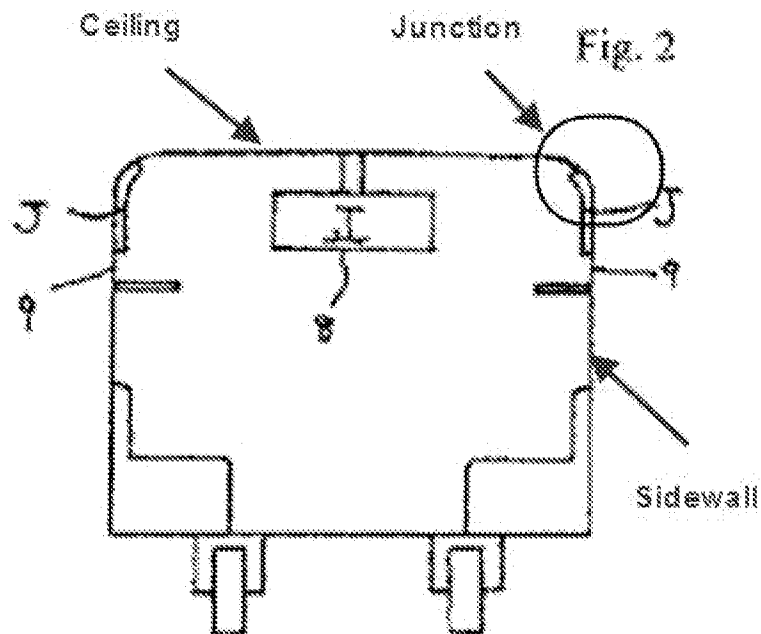

In the annotated Figure 2 above, Minesaki illustrates a ceiling portion, a sidewall portion, and a junction portion between the respective sidewall and ceiling portions (see above). In addition, the monitor (information transmission display part J) is clearly partially mounted and disposed in the junction portion between the respective sidewall and ceiling portions.

Appellant further argues,

Art Unit: 3992

it is believed that this drawing (Fig. 2) is at best unreliable (and at worst, inconsistent) in its teachings when considered without the context of the two configurations discussed supra provided by the written detailed description, and would not expressly or inherently describe a monitor being "mounted at the junction of the sidewall and ceiling" to one of ordinary skill in the art. (Appeal Brief filed 18 March 2013 (hereafter the "Brief"); page 3, last paragraph).

Appellant attempts to argue that Figure 2 is "not intended to be to scale" and "that the drafting quality... is poor". (Brief; page 3, last paragraph). In that regard, the examiner respectfully asserts that patents/publications are relevant as prior art for **all** they contain. MPEP § 2123 states,

"The use of patents as references is not limited to what the patentees describe as their own inventions or to the problems with which they are concerned. They are part of the literature of the art, **relevant for all they contain.**" *In re Heck*, 699 F.2d 1331, 1332-33, 216 USPQ 1038, 1039 (Fed. Cir. 1983) (quoting *In re Lemelson*, 397 F.2d 1006, 1009, 158 USPQ 275, 277 (CCPA 1968)). (emphasis added).

A reference may be relied upon for all that it would have reasonably suggested to one having ordinary skill the art, including nonpreferred embodiments. (See MPEP § 2123).

The examiner respectfully asserts that Figure 2, included above, explicitly discloses monitors **J** being mounted at the junction of the sidewall and ceiling. Regardless of the scale or image quality of Figure 2, Figure 2 is a cross-section drawing of the subway car in which the monitors **J** are specifically positioned on a both a portion of the sidewall and a portion of the junction of the ceiling and the sidewall. Minesaki clearly intended for monitors **J** to be at the interface portion of the subway car, as shown in Figure 2 above since there is no disclosure to other embodiments. Therefore, one of ordinary skill in the art would clearly determine that Minesaki explicitly intended monitors **J** to be mounted

Art Unit: 3992

at the junction of the sidewall and ceiling or Minesaki would not have drawn them as such.

Thus, Minesaki fully meets “each of said monitor being mounted at the junction of the sidewall and ceiling” given its broadest reasonable interpretation.

With respect to Appellant’s reply/argument that Minesaki fails to expressly or inherently describe “with the screen of the monitor substantially flushed with the adjacent wall surface structure of the car”, the examiner respectfully disagrees. Although the claims are interpreted in light of the specification, limitations from the specification are not read into the claims. See *In re Van Geuns*, 988 F.2d 1181, 26 USPQ2d 1057 (Fed. Cir. 1993).

In that regard, it is improper to import claim limitations from the specification. “Although claims of issued patents are interpreted in light of the specification, prosecution history, prior art and other claims, this is not the mode of claim interpretation to be applied during examination. During examination, the claims must be interpreted as broadly as their terms reasonably allow” (see MPEP § 2111). “Though understanding the claim language may be aided by explanations contained in the written description, it is important not to import into a claim limitations that are not part of the claim. For example, a particular embodiment appearing in the written description may not be read into a claim when the claim language is broader than the embodiment” (again see MPEP § 2111).

As asserted in the previous Office action

Art Unit: 3992

(T)he term “substantially” is often used in conjunction with another term to describe a particular characteristic of the claimed invention. It is a broad term. (See MPEP 2173.05).

The recitation to “flush” is modified by the term “substantially” which essentially broadens the recitation of “flush”. The term “flush” is examined as “forming a continuous plane or unbroken surface.”¹ The limitation of “substantially flushed” recites the screen of the monitor not forming a continuous plane or unbroken surface, but to the screen *not wholly forming* a continuous plane or unbroken surface with the adjacent wall surface structure. Appellant discloses

An alternative embodiment is illustrated in FIG. 4A, a view similar to that of FIG. 4. In this alternative embodiment, CRT video monitor 22 is replaced with an LCD-based video monitor 22A which is of thin, rectangular cross-section, and occupies less space in the ceiling structure of the car. Accordingly, it can be moved towards the ceiling so that its viewing screen is substantially flush with or even behind the light panel 40. This use of an LCD-based monitor gives a better aesthetic appearance to the inside of the subway car as a whole, as well as improving the display performance by minimizing the interference effects, as previously discussed. ('602 patent; page 5, lines 35-46)

Included below is Figure 4A.

¹ “flush.” Merriam-Webster Online Dictionary. 2012. Merriam-Webster Online. 10 April 2012 <<http://www.merriam-webster.com/dictionary/flush>>

Art Unit: 3992

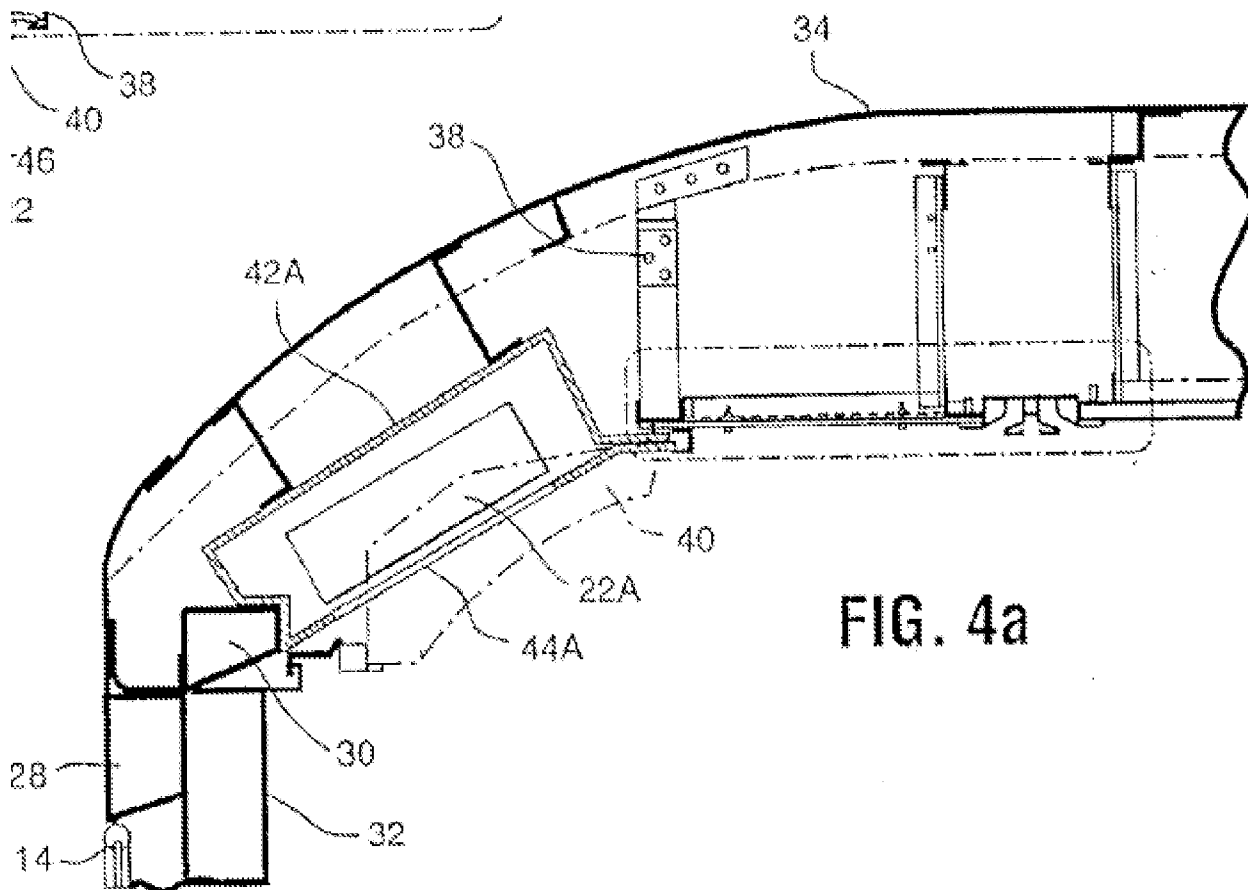

As asserted above, the

*“CRT video monitor is replaced with an LCD-based video monitor **22A** which is of thin, rectangular cross-section, and occupies less space in the ceiling structure of the car”.*

In Figure 4A, Appellant explicitly discloses the monitor **22A** being behind the light panel **40** (see Figure 4A above). Appellant alludes to the monitor **22A** being “substantially flush”, however, never provides explicit disclosure of the embodiment. Moreover, after further examination of Figure 4A, the actual viewing screen of the monitor **22A** can never really be flush with the light panel since the screen of the monitor **22A** is further behind the transport screen **44A** of the appropriately shaped enclosure **42A**, hence

Art Unit: 3992

there is an actual space and/or distance between the actual viewing screen of the monitor **22A** and the transport screen **44A** of the appropriately shaped enclosure **42A**. Furthermore, Appellant never defines the term "flushed" and only alludes to the disclosure of "substantially flushed" in light of Figure 4A. Figure 4A clearly does not show the embodiment of the screen being "flushed" with the adjacent wall surface structure and, additionally provides evidence to the fact that screen of the display monitor can never form a continuous plane or unbroken surface with the adjacent wall surface structure, but can only form a surface that is offset therefrom or "substantially flushed", in light of the Appellant's instant disclosure.

Appellant further argues,

Patent Owner submits that although the screen of the monitor is behind the transport screen in the illustrated embodiment, **the use of the transport screen would give the appearance of a flush mounted monitor (e.g., "substantially flush"), even though the screen of the monitor would actually be slightly offset from the adjacent wall surface structure of the car**. Again, contrast with Minesaki, which illustrates information transmission display parts which would clearly not give the appearance of a flush mounted monitor, instead showing its information transmission display parts sitting of the wall surface. (Brief; page 5, lines 22-28; emphasis added).

Appellant confirms the examiner's position that the monitor is never even "flush" with the adjacent wall at any time and it is the "transport screen" that gives the appearance on the monitor being "substantially flush". Moreover, in examining the term "substantially flush" in light of the claim, there is no claim requirement for the monitor to be behind the wall to give the appearance of the monitor being "substantially flush", only to the screen of the monitor being "substantially flush with the adjacent wall". Thus, a

Art Unit: 3992

monitor protruding somewhat outwardly from the adjacent wall is considered "substantially flush" just as a monitor extending somewhat into adjacent wall is considered "substantially flush", as set forth by the analysis above.

In that light, Minesaki clearly discloses a "liquid crystal panel", **J**, being formed on the sidewall **9** and such a "liquid crystal panel" would have a low profile, as shown above. A "liquid crystal panel" would never be really flush with the sidewall, however, the "liquid crystal panel", **J**, would be "substantially flush", or offset therefrom, in light of the instant Appellant's disclosure.

Thus, Minesaki clearly discloses "the screen of the monitor (being) *substantially flushed* with the adjacent wall surface structure of the car" given its broadest reasonable interpretation.

With respect to Appellant's reply/argument that Minesaki fails to expressly or inherently describe "the screen of the monitor... (being) directed obliquely downwardly toward the car seats", the examiner respectfully disagrees. The Appellant further argues that the recitation to "the screen of the monitor...(being) directed obliquely downwardly toward the car seats" does not include prior art in which "only portions of the screen of the monitor are directed obliquely downwardly". It is noted that the features upon which appellant relies (i.e. the total screen of the monitor being directed obliquely downward toward the car seats) are not recited in the rejected claim(s). Although the claims are interpreted in light of the specification, limitations from the specification are not read into the claims. See *In re Van Geuns*, 988 F.2d 1181, 26 USPQ2d 1057 (Fed. Cir. 1993).

Art Unit: 3992

In that regard, it is improper to import claim limitations from the specification. “Although claims of issued patents are interpreted in light of the specification, prosecution history, prior art and other claims, this is not the mode of claim interpretation to be applied during examination. During examination, the claims must be interpreted as broadly as their terms reasonably allow” (see MPEP § 2111). “Though understanding the claim language may be aided by explanations contained in the written description, it is important not to import into a claim limitations that are not part of the claim. For example, a particular embodiment appearing in the written description may not be read into a claim when the claim language is broader than the embodiment” (again see MPEP § 2111).

It is asserted by the examiner that Appellant has conceded that

“Patent Owner admits that the information transmission display parts J of Minesaki appear curved with the top portion seemingly directed obliquely downwardly...” (Brief; page 6, lines 12-13).

Minesaki clearly discloses portions of the screen of the monitor **J** being directed obliquely downward toward the car seats, as is evidenced by Figure 2. Claim 1 further recites,

the monitors being... directed obliquely downward, **so that each video screen is readily visible to passengers in the subway car.** (Emphasis added).

In examination of Figure 2, any user of the Minesaki subway car, either sitting in the seats provided or standing, would be able to view the monitors from an obliquely oriented perspective.

Appellant further argues,

Art Unit: 3992

that the arrangement illustrated in Minesaki would frustrate the ability for each video screen to be readily visible to passengers if only a portion of the screen were directed obliquely downwardly (due to *inter alia*, optical distortion associated with only the very top portion of light emanating from the screen), and that the Office's interpretation of Patent Owner's language is inconsistent with Patent Owner's specification. (Brief; page 6, lines 12-13).

Again as set forth above, it is improper to import claim limitations from the specification.

“Although claims of issued patents are interpreted in light of the specification, prosecution history, prior art and other claims, this is not the mode of claim interpretation to be applied during examination. During examination, the claims must be interpreted as broadly as their terms reasonably allow” (see MPEP § 2111). “Though understanding the claim language may be aided by explanations contained in the written description, it is important not to import into a claim limitations that are not part of the claim. For example, a particular embodiment appearing in the written description may not be read into a claim when the claim language is broader than the embodiment” (again see MPEP § 2111).

Minesaki is deemed an enabling disclosure for what it teaches. Minesaki explicitly discloses a portion of the monitor being **J** being directed obliquely downward toward the car seats. Minesaki would not frustrate the ability for each passenger to view the video screens. With its specialized orientation, Minesaki provides the ability for both standing and sitting passengers to see what is on the monitors **J**. Therefore, the monitors Minesaki are even more useful than just a monitor that is completely directed obliquely downward toward the car seats and would not frustrate the passenger, but enhance the passenger's experience.

Thus, since portions of the monitor screen of Minesaki are clearly directed obliquely downward toward the car seats, Minesaki fully meets “the screen of the monitor...(being) directed obliquely downward toward the car seats, so that each video screen is readily visible to passengers in the subway car” given its broadest reasonable interpretation.

Issue 2: Rejections of Claim 1 Under 35 U.S.C. 102 as Being Anticipated by Amano et al.

With respect to Appellant’s reply/argument that Amano et al. fails to expressly or inherently describe “with the screen of the monitor substantially flushed with the adjacent wall surface structure of the car”, the examiner respectfully disagrees. Although the claims are interpreted in light of the specification, limitations from the specification are not read into the claims. See *In re Van Geuns*, 988 F.2d 1181, 26 USPQ2d 1057 (Fed. Cir. 1993).

In that regard, it is improper to import claim limitations from the specification. “Although claims of issued patents are interpreted in light of the specification, prosecution history, prior art and other claims, this is not the mode of claim interpretation to be applied during examination. During examination, the claims must be interpreted as broadly as their terms reasonably allow” (see MPEP § 2111). “Though understanding the claim language may be aided by explanations contained in the written description, it is important not to import into a claim limitations that are not part of the claim. For example, a particular embodiment appearing in the written description

Art Unit: 3992

may not be read into a claim when the claim language is broader than the embodiment” (again see MPEP § 2111).

As asserted in the previous Office action

(T)he term “substantially” is often used in conjunction with another term to describe a particular characteristic of the claimed invention. It is a broad term. (See MPEP 2173.05).

The recitation to “flush” is modified by the term “substantially” which essentially broadens the recitation of “flush”. The term “flush” is examined as “forming a continuous plane or unbroken surface.”² The limitation of “substantially flushed” recites the screen of the monitor not forming a continuous plane or unbroken surface, but to the screen *not wholly forming* a continuous plane or unbroken surface with the adjacent wall surface structure. Owner discloses

*An alternative embodiment is illustrated in FIG. 4A, a view similar to that of FIG. 4. In this alternative embodiment, CRT video monitor **22** is replaced with an LCD-based video monitor **22A** which is of thin, rectangular cross-section, and occupies less space in the ceiling structure of the car. Accordingly, it can be moved towards the ceiling so that its viewing screen is substantially flush with or even behind the light panel **40**. This use of an LCD-based monitor gives a better aesthetic appearance to the inside of the subway car as a whole, as well as improving the display performance by minimizing the interference effects, as previously discussed. (Page 5, lines 35-46)*

Included below is Figure 4A.

² “flush.” Merriam-Webster Online Dictionary. 2012. Merriam-Webster Online. 10 April 2012 <<http://www.merriam-webster.com/dictionary/flush>>

Art Unit: 3992

actual space and/or distance between the actual viewing screen of the monitor **22A** and the transport screen **44A** of the appropriately shaped enclosure **42A**. Furthermore, Owner never defines the term “flushed” and only alludes to the disclosure of “substantially flushed” in light of Figure 4A. Figure 4A clearly does not show the embodiment of the screen being “flushed” with the adjacent wall surface structure and, additionally provides evidence to the fact that screen of the display monitor can never form a continuous plane or unbroken surface with the adjacent wall surface structure, but can only form a surface that is offset therefrom or “substantially flushed”, in light of the Owner's instant disclosure.

In that light, Amano et al. clearly discloses “information signal devices **8a-8n**” being formed on the transitional portion of the sidewalls, as shown in Figures 4, 5 and 6. The “information signal devices **8a-8n**” would never be really flush with the sidewall, however, the “information signal devices **8a-8n**” would be “substantially flush”, or offset therefrom, in light of the instant Owner's disclosure. Therefore, Amano et al. clearly discloses “the screen of the monitor (being) substantially flushed with the adjacent wall surface structure of the car” given its broadest reasonable interpretation.

In addition, Appellant argues,

Patent Owner respectfully submits that the Office's interpretation of the term “substantially flushed” is improper, as the Office's interpretation completely reads out the “flushed” feature and obscures what is meant by “substantially flushed” as clearly described throughout Patent Owner's specification and figures. Patent Owner's specification clearly describes a subway car with video monitors that appear integral with the design of the subway car (see, e.g., Col. 4, lines 8 – 13 of Patent Owner's specification). **Furthermore, the Patent Owner's specification and figures are indicative of monitors that are built within the**

Art Unit: 3992

inner spaces and below the surface structure of the interior of the subway car so as to achieve the stated goal of making the video display monitors appear integral with the inside structure of the subway car (see e.g., Col. 3, line 55 to Col. 4, line 9). (Brief; page 8, lines 5-14).

As set forth above, it is improper to import claim limitations from the specification.

“Although claims of issued patents are interpreted in light of the specification, prosecution history, prior art and other claims, this is not the mode of claim interpretation to be applied during examination. During examination, the claims must be interpreted as broadly as their terms reasonably allow” (see MPEP § 2111). “Though understanding the claim language may be aided by explanations contained in the written description, it is important not to import into a claim limitations that are not part of the claim. For example, a particular embodiment appearing in the written description may not be read into a claim when the claim language is broader than the embodiment” (again see MPEP § 2111).

Appellant confirms the examiner’s position that the monitor is never “integral” with the adjacent wall at any time and it is placed inside the wall to make the monitor appear integral”. Moreover, there is no prerequisite in the claim that the monitor be “*within the inner space a below the surface structure of the interior of the subway car*”, only to the monitor being “substantially flushed”.

Thus, the argument to the actual orientation of the monitor to the surrounding structure, other than “substantially flushed” is moot.

Appellant further argues,

Art Unit: 3992

Patent Owner submits that although the screen of the monitor is behind the transport screen in the illustrated embodiment, **the use of the transport screen would give the appearance of a flush mounted monitor (e.g., "substantially flush"), even though the screen of the monitor would actually be slightly offset from the adjacent wall surface structure of the car.** Again, contrast with Amano, which illustrates information transmission display devices which would clearly not give the appearance of a flush mounted monitor. (Brief; page 8, lines 25-30; emphasis added).

Appellant confirms the examiner's position that the monitor is never even "flush" with the adjacent wall at any time and it is the "transport screen" that gives the appearance on the monitor being "substantially flush". Moreover, in examining the term "substantially flush" in light of the claim, there is no claim requirement for the monitor to be behind the wall to give the appearance of the monitor being "substantially flush", only to the screen of the monitor being "substantially flush with the adjacent wall". Thus, a monitor protruding somewhat outwardly from the adjacent wall is considered "substantially flush" just as a monitor extending somewhat into adjacent wall is considered "substantially flush", as set forth by the analysis above.

Thus, Amano et al. clearly discloses "the screen of the monitor (being) *substantially flushed* with the adjacent wall surface structure of the car" given its broadest reasonable interpretation.

Issue 3: Rejection of Claim 1 Under 35 U.S.C. 103 as Being Obvious over Maekawa in View of Amano.

With respect to Appellant's reply/argument that Maekawa et al. fails to teach or suggest "the screen of the monitor (is) substantially flushed with the adjacent wall surface structure of the car", the examiner respectfully disagrees. Although the claims

Art Unit: 3992

are interpreted in light of the specification, limitations from the specification are not read into the claims. See *In re Van Geuns*, 988 F.2d 1181, 26 USPQ2d 1057 (Fed. Cir. 1993).

In that regard, it is improper to import claim limitations from the specification. “Although claims of issued patents are interpreted in light of the specification, prosecution history, prior art and other claims, this is not the mode of claim interpretation to be applied during examination. During examination, the claims must be interpreted as broadly as their terms reasonably allow” (see MPEP § 2111). “Though understanding the claim language may be aided by explanations contained in the written description, it is important not to import into a claim limitations that are not part of the claim. For example, a particular embodiment appearing in the written description may not be read into a claim when the claim language is broader than the embodiment” (again see MPEP § 2111).

As asserted in the previous Office action

(T)he term “substantially” is often used in conjunction with another term to describe a particular characteristic of the claimed invention. It is a broad term. (See MPEP 2173.05).

The recitation to “flush” is modified by the term “substantially” which essentially broadens the recitation of “flush”. The term “flush” is examined as “forming a continuous plane or unbroken surface.”³ The limitation of “substantially flushed” recites the screen of the monitor not forming a continuous plane or unbroken surface, but to the screen not

³ “flush.” Merriam-Webster Online Dictionary. 2012. Merriam-Webster Online. 10 April 2012 <<http://www.merriam-webster.com/dictionary/flush>>

Art Unit: 3992

wholly forming a continuous plane or unbroken surface with the adjacent wall surface structure. Owner discloses

An alternative embodiment is illustrated in FIG. 4A, a view similar to that of FIG. 4. In this alternative embodiment, CRT video monitor 22 is replaced with an LCD-based video monitor 22A which is of thin, rectangular cross-section, and occupies less space in the ceiling structure of the car. Accordingly, it can be moved towards the ceiling so that its viewing screen is substantially flush with or even behind the light panel 40. This use of an LCD-based monitor gives a better aesthetic appearance to the inside of the subway car as a whole, as well as improving the display performance by minimizing the interference effects, as previously discussed. (Page 5, lines 35-46)

Included below is Figure 4A.

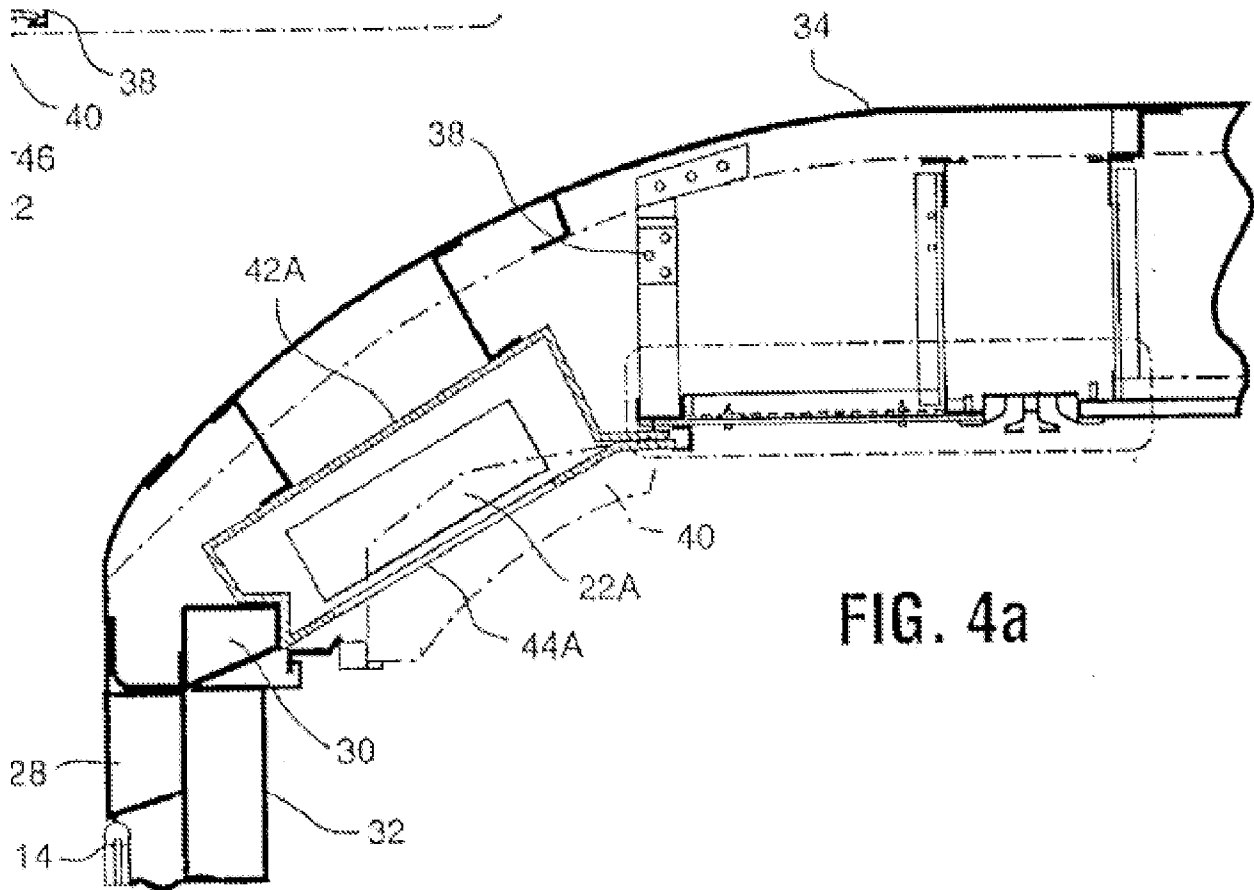

As asserted above, the

Art Unit: 3992

*“CRT video monitor is replaced with an LCD-based video monitor **22A** which is of thin, rectangular cross-section, and occupies less space in the ceiling structure of the car”.*

In Figure 4A, Owner explicitly discloses the monitor **22A** being behind the light panel **40** (see Figure 4A above). Owner alludes to the monitor **22A** being “substantially flush”, however, never provides explicit disclosure of the embodiment. Moreover, after further examination of Figure 4A, the actual viewing screen of the monitor **22A** can never really be flush with the light panel since the screen of the monitor **22A** is further behind the transport screen **44A** of the appropriately shaped enclosure **42A**, hence there is an actual space and/or distance between the actual viewing screen of the monitor **22A** and the transport screen **44A** of the appropriately shaped enclosure **42A**. Furthermore, Owner never defines the term “flushed” and only alludes to the disclosure of “substantially flushed” in light of Figure 4A. Figure 4A clearly does not show the embodiment of the screen being “flushed” with the adjacent wall surface structure and, additionally provides evidence to the fact that screen of the display monitor can never form a continuous plane or unbroken surface with the adjacent wall surface structure, but can only form a surface that is offset therefrom or “substantially flushed”, in light of the Owner's instant disclosure.

In that light, Maekawa et al. clearly discloses the screen (**display**) of the plurality of monitor (**101-124**) being placed on the sidewall so that each video screen (**display**) is readily visible to passengers in the subway car, as is evidenced by Figure 2. In addition, Maekawa et al. discloses the plurality of monitors (**101-124**) being a “liquid crystal panel” having a low profile (page 738, bottom right portion). A “liquid crystal panel”

Art Unit: 3992

would never be really flush with the sidewall, however, the "liquid crystal panel", would be "substantially flush", or offset therefrom, in light of the instant Owner's disclosure.

Appellant further argues,

Patent Owner submits that although the screen of the monitor is behind the transport screen in the illustrated embodiment, **the use of the transport screen would give the appearance of a flush mounted monitor (e.g., "substantially flush"), even though the screen of the monitor would actually be slightly offset from the adjacent wall surface structure of the car**. Again, contrast with Maekawa, which illustrates information transmission display devices which would clearly not give the appearance of a flush mounted monitor, instead showing its monitors sitting on top of the wall surface. (Brief; page 10, lines 9-15; emphasis added).

Appellant confirms the examiner's position that the monitor is never even "flush" with the adjacent wall at any time and it is the "transport screen" that gives the appearance on the monitor being "substantially flush". Moreover, in examining the term "substantially flush" in light of the claim, there is no claim requirement for the monitor to be behind the wall to give the appearance of the monitor being "substantially flush", only to the screen of the monitor being "substantially flush with the adjacent wall". Thus, a monitor protruding somewhat outwardly from the adjacent wall is considered "substantially flush" just as a monitor extending somewhat into adjacent wall is considered "substantially flush", as set forth by the analysis above.

Thus, Maekawa et al. clearly discloses "the screen of the monitor (being) substantially flushed with the adjacent wall surface structure of the car" given its broadest reasonable interpretation.

**Issue 5: Rejection of Claim 1 Under 35 U.S.C. 103 as Being Obvious over
Minesaki in View of Moore.**

With respect to Appellant's reply/argument that Minesaki fails to teach or suggest: (1) "*each of said monitor being mounted at the junction of the sidewall and ceiling*"; and (2) "*directed obliquely downwardly toward the car seats*", the examiner respectfully disagrees. This argument has already been addressed by the examiner directly above. See pages 23-26 and 30-33, which are hereby incorporated by reference.

In response to Appellant's argument that the examiner's conclusion of obviousness is based upon improper hindsight reasoning, it must be recognized that any judgment on obviousness is in a sense necessarily a reconstruction based upon hindsight reasoning. But so long as it takes into account only knowledge which was within the level of ordinary skill at the time the claimed invention was made, and does not include knowledge gleaned only from the applicant's disclosure, such a reconstruction is proper. See *In re McLaughlin*, 443 F.2d 1392, 170 USPQ 209 (CCPA 1971).

Appellant further argues,

nothing within the teachings of Minesaki teaches or suggests the availability of space beyond the wall into which the rear end of the monitor may project. Accordingly, Patent Owner submits that the only such reasoning for making such a combination is gleaned entirely from Patent Owner's disclosure, as nothing within the teachings of Minesaki suggests the availability of space or the desirability of the proposed combination. (Brief, page 11, lines 11-16).

Art Unit: 3992

Appellant essentially argues that since Minesaki does not disclose any space or desirability for the combination of the "substantially flush" configuration of Moore et al., the combination of Minesaki and Moore et al. is improper. However, the examiner respectfully asserts that this argument is misplaced, since it is the combination of Minesaki and Moore et al. that is pertinent, not whether there is "space" in one reference and "no space" in the other.

In this regard, the test for obviousness is not whether the features of a secondary reference may be bodily incorporated into the structure of the primary reference; nor is it that the claimed invention must be expressly suggested in any one or all of the references. Rather, the test is what the combined teachings of the references would have suggested to those of ordinary skill in the art. See *In re Keller*, 642 F.2d 413, 208 USPQ 871 (CCPA 1981).

In this regard, Minesaki, explicitly discloses monitors being mounted at the junction of a ceiling and wall, with each monitor being directed obliquely downward toward the car seats. However, Minesaki is silent to an exact configuration of the wall/monitor structural interface. (Minesaki; see Figure 2). Prior art to Moore et al. teaches the mounting of monitors into walls and providing either a flush or "substantially flush" (i.e. projecting slightly beyond the surface of the wall) configuration depending on spacing. (Moore et al.; column 7, lines 41-46). One of ordinary skill in the art would clearly look to the monitor mounting teachings of Moore et al. and improve Minesaki's silent subway car wall/monitor structural interface since it is known in the art that subway cars have thin wall construction. The MPEP further states,

Art Unit: 3992

[t]he mere fact that references can be combined or modified does not render the resultant combination obvious unless ** > the results would have been predictable to one of ordinary skill in the art. *KSR International Co. v. Teleflex Inc.*, 550 U.S. ___, ___, 82 USPQ2d 1385, 1396 (2007) (“If a person of ordinary skill can implement a predictable variation, § 103 likely bars its patentability. **For the same reason, if a technique has been used to improve one device, and a person of ordinary skill in the art would recognize that it would improve similar devices in the same way, using the technique is obvious unless its actual application is beyond his or her skill.**”). (MPEP § 2143.01).

This combination of references (i.e. Minesaki and Moore et al.) satisfies at least rationales A-D identified by the Supreme Court in *KSR International Co. v. Teleflex Inc.*, 550 U.S. ___, ___, 82 USPQ2d 1385, 1395-97 (2007): “Combining prior art elements according to known methods to yield predictable results”; “Simple substitution of one known element for another to obtain predictable results”; “Use of known technique to improve similar devices (methods, or products) in the same way”; and “Applying a known technique to a known device (method, or product) ready for improvement to yield predictable results.” (See MPEP 2143; Also see Final Office, pages 10-13).

Thus, the examiner respectfully asserts that the examiner’s reasoning did not constitute “impermissible hindsight” and that a *prima facie* case of obviousness for placing monitors “substantially flush” with adjacent walls of a subway car was set forth appropriately.

Issue 6: Rejection of Claim 1 Under 35 U.S.C. 103 as Being Obvious over Amano in View of Moore.

With respect to Appellant’s reply/argument that Amano et al. fails to teach or suggest: (1) “*each of said monitor being mounted at the junction of the sidewall and*

Art Unit: 3992

ceiling”, the examiner respectfully disagrees. This argument has already been addressed by the examiner directly above. See pages 33-38, which are hereby incorporated by reference.

Amano et al. Specifically teaches “*each of said monitor being mounted at the junction of the sidewall and ceiling*” in Figures 4-6.

In response to Appellant’s argument that the examiner's conclusion of obviousness is based upon improper hindsight reasoning, it must be recognized that any judgment on obviousness is in a sense necessarily a reconstruction based upon hindsight reasoning. But so long as it takes into account only knowledge which was within the level of ordinary skill at the time the claimed invention was made, and does not include knowledge gleaned only from the applicant's disclosure, such a reconstruction is proper. See *In re McLaughlin*, 443 F.2d 1392, 170 USPQ 209 (CCPA 1971).

Appellant further argues,

nothing within the teachings of Amano teaches or suggests the availability of space beyond the wall into which the rear end of the monitor may project. Accordingly, Patent Owner submits that the only such reasoning for making such a combination is gleaned entirely from Patent Owner's disclosure, as nothing within the teachings of Amano suggests the availability of space or the desirability of the proposed combination. (Brief, page 13, lines 36-41).

Appellant essentially argues that since Amano et al. does not disclose any space or desirability for the combination of the “substantially flush” configuration of Moore et al., the combination of Amano et al. and Moore et al. is improper. However, the examiner respectfully asserts that this argument is misplaced, since it is the combination of

Art Unit: 3992

Amano et al. and Moore et al. that is pertinent, not whether there is "space" in one reference and "no space" in the other.

In this regard, the test for obviousness is not whether the features of a secondary reference may be bodily incorporated into the structure of the primary reference; nor is it that the claimed invention must be expressly suggested in any one or all of the references. Rather, the test is what the combined teachings of the references would have suggested to those of ordinary skill in the art. See *In re Keller*, 642 F.2d 413, 208 USPQ 871 (CCPA 1981).

In this regard, Amano et al., explicitly discloses monitors being mounted at the junction of a ceiling and wall, with each monitor being directed obliquely downward toward the car seats. (Amano et al.; see Figures 4-6). Prior art to Moore et al. teaches the mounting of monitors into walls and providing either a flush or "substantially flush" (i.e. projecting slightly beyond the surface of the wall) configuration depending on spacing. (Moore et al.; column 7, lines 41-46). One of ordinary skill in the art would clearly look to the monitor mounting teachings of Moore et al. and improve Amano et al.'s silent subway car wall/monitor structural interface since it is known in the art that subway cars have thin wall construction. The MPEP further states,

[t]he mere fact that references can be combined or modified does not render the resultant combination obvious unless ** > the results would have been predictable to one of ordinary skill in the art. *KSR International Co. v. Teleflex Inc.*, 550 U.S. ___, ___, 82 USPQ2d 1385, 1396 (2007) ("If a person of ordinary skill can implement a predictable variation, § 103 likely bars its patentability. **For the same reason, if a technique has been used to improve one device, and a person of ordinary skill in the art would recognize that it would improve similar devices in the same way, using the technique is obvious unless its actual application is beyond his or her skill.**"). (MPEP § 2143.01).

Art Unit: 3992

This combination of references (i.e. Amano et al. and Moore et al.) satisfies at least rationales A-D identified by the Supreme Court in *KSR International Co. v. Teleflex Inc.*, 550 U.S. ~, ___, 82 USPQ2d 1385, 1395-97 (2007): "Combining prior art elements according to known methods to yield predictable results"; "Simple substitution of one known element for another to obtain predictable results"; "Use of known technique to improve similar devices (methods, or products) in the same way"; and "Applying a known technique to a known device (method, or product) ready for improvement to yield predictable results." (See MPEP 2143; Also see Final Office, pages 13-16).

Thus, the examiner respectfully asserts that the examiner's reasoning did not constitute "impermissible hindsight" and that a *prima facie* case of obviousness for the placing of monitors "substantially flush" with adjacent walls of a subway car was set forth appropriately.

Issues 7 and 8: Rejection of Claim 1 under 35 U.S.C. 103(a) as being unpatentable over Maekawa et al. and/or Shinagawa et al., either in view of Amano et al. and Moore et al.

Furthermore, in response to Owner's reply/ argument that the modifications to the area near the junction of the sidewall and ceiling of the Amano et al. train would render the Amano et al. train unsatisfactory for its intended purpose because the storage area would have to be eliminated entirely or substantially reduced, the test for obviousness is not whether the features of a secondary reference may be bodily incorporated into the structure of the primary reference; nor is it that the claimed

Art Unit: 3992

invention must be expressly suggested in any one or all of the references. Rather, the test is what the combined teachings of the references would have suggested to those of ordinary skill in the art. See *In re Keller*, 642 F.2d 413, 208 USPQ 871 (CCPA 1981).

In that light, the storage devices of Amano et al. are permanent structures of the train, as is evidenced by Figures 4-6. Specifically, the storage area structures in Figures 5 and 6 are independent of the information signal display devices **8**. Similarly, the storage device in Figure 4 seems to have a slotted area in which one of ordinary skill in the art would render the information signal display devices **8** as also being independent from the storage device. Clearly, the modification of the information signal display devices **8** of Amano et al. to be “substantially flushed”, as taught by Moore et al., would not destroy the functionality of the storage devices of Amano et al, but instead, provide even more potential area for storage. Therefore, the examiner asserts that the replacement of the slightly protruding information signal display devices **8** of Amano et al. with the “substantially flushed” monitors of Moore et al. would not render Amano et al. unsatisfactory for its intended purpose because Amano et al. would still provide real-time information to the users of the train via the monitors as well as potentially even more adequate storage for particular items.

In response to Appellant’s argument that the examiner's conclusion of obviousness is based upon improper hindsight reasoning, it must be recognized that any judgment on obviousness is in a sense necessarily a reconstruction based upon hindsight reasoning. But so long as it takes into account only knowledge which was

Art Unit: 3992

within the level of ordinary skill at the time the claimed invention was made, and does not include knowledge gleaned only from the applicant's disclosure, such a reconstruction is proper. See *In re McLaughlin*, 443 F.2d 1392, 170 USPQ 209 (CCPA 1971).

Appellant further argues,

nothing within the teachings of Maekawa teaches or suggests the availability of space beyond the wall into which the rear end of the monitor may project. Accordingly, Patent Owner submits that the only such reasoning for making such a combination is gleaned entirely from Patent Owner's disclosure, as nothing within the teachings of Maekawa suggests the availability of space or the desirability of the proposed combination. (Brief, pages 14, line 43 – page 15, line 2).

Appellant essentially argues that since Maekawa does not disclose any space or desirability for the combination of the “substantially flush” configuration of Moore et al., the combination of Maekawa and Moore et al. is improper. However, the examiner respectfully asserts that this argument is misplaced, since it is the combination of Maekawa and Moore et al. that is pertinent, not whether there is “space” in one reference and “no space” in the other.

In this regard, the test for obviousness is not whether the features of a secondary reference may be bodily incorporated into the structure of the primary reference; nor is it that the claimed invention must be expressly suggested in any one or all of the references. Rather, the test is what the combined teachings of the references would have suggested to those of ordinary skill in the art. See *In re Keller*, 642 F.2d 413, 208 USPQ 871 (CCPA 1981).

Art Unit: 3992

In this regard, Maekawa and Shinagawa disclose providing monitors on the side walls of a rain car. (Maekawa; page 738, lower right paragraphs; see Figures 1, 2; Shinagawa; page 621, lower left paragraphs; see Figure 4). Prior art to Amano et al., explicitly teaches monitors being mounted at the junction of a ceiling and wall, with each monitor being directed obliquely downward toward the car seats. (Amano et al.; see English translation Abstract; see Figures 4-6). Moreover, prior art to Moore et al. teaches the mounting of monitors into walls and providing either a flush or "substantially flush" (i.e. projecting slightly beyond the surface of the wall) configuration depending on spacing. (Moore et al.; column 7, lines 41-46). One of ordinary skill in the art would clearly look to the monitor mounting teachings of Amano et al. and Moore et al. and improve either Maekawa's and/or Shinagawa's subway car wall/monitor structural interface since it is known in the art that subway cars have thin wall construction and the need for sharper images. The MPEP further states,

[t]he mere fact that references can be combined or modified does not render the resultant combination obvious unless ** > the results would have been predictable to one of ordinary skill in the art. *KSR International Co. v. Teleflex Inc.*, 550 U.S. ___, ___, 82 USPQ2d 1385, 1396 (2007) ("If a person of ordinary skill can implement a predictable variation, § 103 likely bars its patentability. **For the same reason, if a technique has been used to improve one device, and a person of ordinary skill in the art would recognize that it would improve similar devices in the same way, using the technique is obvious unless its actual application is beyond his or her skill.**"). (MPEP § 2143.01).

This combination of references (i.e. Maekawa and/or Shinagawa in view of Amano et al. and Moore et al.) satisfies at least rationales A-D identified by the Supreme Court in *KSR International Co. v. Teleflex Inc.*, 550 U.S. ~, ___, 82 USPQ2d 1385, 1395-97 (2007): "Combining prior art elements according to known methods to yield predictable

Art Unit: 3992

results”; “Simple substitution of one known element for another to obtain predictable results”; “Use of known technique to improve similar devices (methods, or products) in the same way”; and “Applying a known technique to a known device (method, or product) ready for improvement to yield predictable results.” (See MPEP 2143; Also see Final Office, pages 13-16).

Thus, the examiner respectfully asserts that the examiner’s reasoning did not constitute “impermissible hindsight” and that a *prima facie* case of obviousness for the placing of monitors “*substantially flush*” with adjacent walls of a subway car “*at the junction of the sidewall and ceiling with the monitors being directed obliquely downward towards the car seat*” was set forth appropriately.

In conclusion, the claims on appeal are not novel as it pertains to a subway car having monitors in which the screens of the monitors are substantially flushed with the adjacent wall surface at the junction of the sidewall and ceiling with the monitors being directed obliquely downward toward the car seats. The examiner has provided proper evidence to anticipation as well as evidence to support a *prima facie* case of obviousness with respect to the rejections asserted above. The examiner respectfully requests that the rejections of the claims be affirmed and that such claims be indicated as not inventive or allowable over the prior art of record.

Art Unit: 3992

For the above reasons, it is believed that the rejections should be sustained.

Respectfully submitted,

/Stephen J Ralis/
Primary Examiner, Art Unit 3992

Conferees:

/Luke S. Wassum/
Primary Examiner, Art Unit 3992

/Sudhanshu C Pathak/
Supervisory Patent Examiner, Art Unit
3992

SJR
July 1, 2013



UNITED STATES PATENT AND TRADEMARK OFFICE

UNITED STATES DEPARTMENT OF COMMERCE
United States Patent and Trademark Office
Address: COMMISSIONER FOR PATENTS
P.O. Box 1450
Alexandria, Virginia 22313-1450
www.uspto.gov

APPLICATION NO.	FILING DATE	FIRST NAMED INVENTOR	ATTORNEY DOCKET NO.	CONFIRMATION NO.
90/011,861	08/16/2011	6700602	BLAIR.001A	3736
27299	7590	10/03/2013	EXAMINER	
GAZDZINSKI & ASSOCIATES, PC 16644 WEST BERNARDO DRIVE SUITE 201 SAN DIEGO, CA 92127			RALIS, STEPHEN J	
			ART UNIT	PAPER NUMBER
			3992	
			MAIL DATE	DELIVERY MODE
			10/03/2013	PAPER

Please find below and/or attached an Office communication concerning this application or proceeding.

The time period for reply, if any, is set in the attached communication.



United States Patent and Trademark Office

Under Secretary of Commerce for Intellectual Property and
Director of the United States Patent and Trademark Office

P.O. Box 1450
Alexandria, Virginia 22313-1450
www.uspto.gov

GAZDZINSKI & ASSOCIATES, PC
16644 WEST BERNARDO DRIVE
SUITE 201
SAN DIEGO, CA 92127

Appeal No: 2014-000060
Application: 90/011,861
Appellant: Scott Blair

Patent Trial and Appeal Board Docketing Notice

Application 90/011,861 was received from the Technology Center at the Board on September 25, 2013 and has been assigned Appeal No: 2014-000060.

In all future communications regarding this appeal, please include both the application number and the appeal number.

The mailing address for the Board is:

PATENT TRIAL and APPEAL BOARD
UNITED STATES PATENT AND TRADEMARK OFFICE
P.O. BOX 1450
ALEXANDRIA, VIRGINIA 22313-1450

Telephone inquiries can be made by calling 571-272-9797 and referencing the appeal number listed above.

By order of the Patent Trial and Appeal Board.



UNITED STATES PATENT AND TRADEMARK OFFICE

UNITED STATES DEPARTMENT OF COMMERCE
United States Patent and Trademark Office
Address: COMMISSIONER FOR PATENTS
P.O. Box 1450
Alexandria, Virginia 22313-1450
www.uspto.gov

APPLICATION NO.	FILING DATE	FIRST NAMED INVENTOR	ATTORNEY DOCKET NO.	CONFIRMATION NO.
90/011,861	08/16/2011	6700602	BLAIR.001A	3736
27299	7590	06/30/2014	EXAMINER	
GAZDZINSKI & ASSOCIATES, PC 16644 WEST BERNARDO DRIVE SUITE 201 SAN DIEGO, CA 92127			RALIS, STEPHEN J	
			ART UNIT	PAPER NUMBER
			3992	
			MAIL DATE	DELIVERY MODE
			06/30/2014	PAPER

Please find below and/or attached an Office communication concerning this application or proceeding.

The time period for reply, if any, is set in the attached communication.

UNITED STATES PATENT AND TRADEMARK OFFICE

BEFORE THE PATENT TRIAL AND APPEAL BOARD

Ex parte SCOTT BLAIR
Patent Owner, Appellant

Appeal 2014-000060
Reexamination Control 90/011,861
Patent US 6,700,602 B1¹
Technology Center 3900

Before CAROLYN D. THOMAS, ELENI MANTIS MERCADER, and
DANIEL N. FISHMAN, *Administrative Patent Judges*.

MANTIS MERCADER, *Administrative Patent Judge*.

DECISION ON APPEAL

¹ Issued Mar. 2, 2004 to Blair (hereinafter the “’602 Patent”).

STATEMENT OF THE CASE

The Patent Owner (hereinafter “Appellant”) appeals under 35 U.S.C. §§ 134(b) and 306 from the Final Rejection of claim 1.² Br. 1.

We reverse.

We have considered in this decision only those arguments Appellant actually raised in the Briefs. Any other arguments which Appellant could have made but chose not to make in the Briefs are deemed to be waived. *See* 37 C.F.R. § 41.37(c)(1)(vii).

Appellant’s Invention

Appellant’s invention relates to a television system, for subway cars including a plurality of TV monitors mounted at the junction of the sidewall and ceiling. *See generally* ’602 Patent, Abstract.

Claim 1 under reexamination is reproduced as follows:

1. A subway car for mass transportation including longitudinal opposed sidewalls, a ceiling adjoining the sidewalls, a video display system comprising a plurality of video display monitors each having a video screen, and a video signal source unit operatively connected to said monitors,

said monitors being spaced along the length of the car on opposed sides thereof, each of said monitor being mounted at

² In response to Patent Owner’s Request for *Ex Parte* Reexamination filed August 16, 2011, seeking reexamination of independent claim 1, an Order Granting Request for *Ex Parte* Reexamination was issued on September 29, 2011, ordering reexamination of claim 1. During reexamination, Patent Owner presented new claims 8-30. Claims 2-7 are not subject to reexamination, claims 8-18, and 20-30 stand patentable and/or confirmed, and claim 19 is canceled. Final Action 2 (mailed Apr. 25, 2012); Advisory Action 2, 22-23 (mailed Jan. 16, 2013).

the junction of the sidewall and ceiling, with the screen of the monitor substantially flushed with the adjacent wall surface structure of the car, and directed obliquely downwardly toward the car seats, so that each video screen is readily visible to passengers in the subway car.

The Examiner's Rejections

1. Claim 1 stands rejected under 35 U.S.C. § 102(b) as being anticipated by Minesaki (JP 63-125984, pub. May 30, 1988).
2. Claim 1 stands rejected under 35 U.S.C. § 102(b) as being anticipated by Amano (JP H2-223985, pub. Sept. 6, 1990).
3. Claim 1 stands rejected under 35 U.S.C. § 103(a) as being unpatentable over Maekawa (JP H04-160991, pub. June 4, 1992) and Amano.
4. Claim 1 stands rejected under 35 U.S.C. § 103(a) as being unpatentable over Minesaki and Moore (US 3,480,727, issued Nov. 25, 1969).
5. Claim 1 stands rejected under 35 U.S.C. § 103(a) as being unpatentable over Amano and Moore.
6. Claim 1 stands rejected under 35 U.S.C. § 103(a) as being unpatentable over Maekawa, Amano, and Moore.
7. Claim 1 stands rejected under 35 U.S.C. § 103(a) as being unpatentable over Shinagawa (JP S61-285490, pub. Dec. 16, 1986), Amano, and Moore.

ANALYSIS

Claim 1 rejected under 35 U.S.C. § 102(b) as anticipated by Minesaki

Appellant argues, *inter alia*, that Minesaki fails to teach the limitation of “each of said monitor being mounted at the junction of a sidewall and ceiling” as recited in claim 1 (Br. 3). In particular, Appellant argues that “[w]hen the reference does not disclose that the drawings are to scale and is silent as to dimensions, arguments based on measurement of the drawing features are of little value” (Br. 3 (quoting MPEP § 2125 (emphasis and internal quotation marks omitted))). *See Hockerson-Halberstadt, Inc. v. Avia Group Int'l*, 222 F.3d 951, 956 (Fed. Cir. 2000). Appellant asserts that in Figure 2, the information transmission display parts J are shown as being curved along the top portion of the display and Minesaki provides no mention or explanation for this curvature in its specification, which would be unusual in that optically such a curve would distort the light rays emanating from the display in an inconsistent manner causing image distortion (Br. 3).

We agree with Appellant’s argument. Figure 2 certainly shows the monitors are mounted at the sidewalls but it is unclear from the informal drawings whether the monitors necessarily extend at the *junctions of the sidewalls and the ceilings*. It could be that the monitors are merely on the sidewalls. “The mere fact that a certain thing *may* result from a given set of circumstances is not sufficient” under anticipation principles. *In re Robertson*, 169 F.3d 743, 745 (Fed. Cir. 1999) (emphasis added) (citations and internal quotation marks omitted).

Accordingly, we reverse the Examiner's rejection of claim 1 as anticipated by Minesaki.

Claim 1 rejected under 35 U.S.C. § 102(b) as anticipated by Amano

Appellant argues that Amano fails to teach the limitation of “the screen of the monitor substantially flushed with the adjacent wall surface structure of the car” as recited in claim 1 (Br. 6). Appellant particularly argues that “substantially” cannot be construed so broadly as to read the term “flushed” completely out of the claim (Br. 6-7).

We agree with Appellant's argument. The term “substantially” is defined, in pertinent part, as “to a great extent or degree [.]” THE FREE DICTIONARY, <http://www.thefreedictionary.com/substantially> (last visited June 26, 2014). Amano's Figures 4-6 cited by the Examiner, especially looking at the side views of the drawings show the screens of the monitors being located at quite some distance away from the surface structure of the car, and thus, not being reasonably “substantially” or to a great extent *flushed* against the surface (*see* for example, Amano's Figure 4 reproduced below).

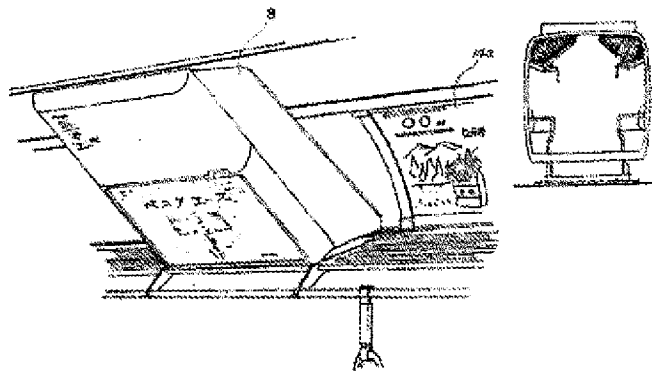

Figure 4 shows the side view of the screen extending some distance away from the surface of the car.

Accordingly, we reverse the Examiner's rejection of claim 1 as anticipated by Amano.

Claim 1 rejected under 35 U.S.C. § 103(a) as unpatentable over Maekawa in view of Amano

Appellant argues, *inter alia*, that Maekawa's Figure 2 shows the monitors on top of the surface structure of the car, and thus, Maekawa does not show the screens being *substantially flushed* against the car surface (Br. 9-10).

We agree with Appellant. The term "flush" is described in pertinent part as "a surface exactly even with an adjoining one[.]" Vocabulary.com, <http://www.vocabulary.com/dictionary/flush> (last visited June 26, 2014). As stated *supra*, "substantially" means to a great extent, and thus, "substantially flush" would mean a surface which is to a great extent even with an adjoining one. Thus, we agree with Appellant that a screen located at a monitor on top of the surface of the car would not be substantially flushed against the car surface.

Accordingly, we reverse the Examiner's rejection of claim 1 as obvious over Maekawa in view of Amano.

Claim 1 rejected under 35 U.S.C. § 103(a) as unpatentable over Minesaki in view of Moore

Appellant repeats the same argument as that presented for claim 1 as anticipated by Minesaki as addressed *supra* (Br. 10-11).

Accordingly, we reverse claim 1 for the same reasons as stated above.

Appeal 2014-000060
Reexamination Control 90/011,861
Patent US 6,700,602 B1

Claim 1 rejected under 35 U.S.C. § 103(a) as unpatentable over Amano in view of Moore

Appellant repeats the same argument as that presented for claim 1 as anticipated by Amano as addressed *supra* (Br. 11-12).

Thus, we reverse claim 1 for the same reasons as stated above.

Claim 1 rejected under 35 U.S.C. § 103(a) as unpatentable over Maekawa and/or Shinagawa in view of Amano and Moore

Appellant repeats the same argument as that presented for claim 1 as anticipated by Amano as addressed *supra* (Br. 14).

Thus, we reverse claim 1 for the same reasons as stated above.

CONCLUSION

Based on the analysis above, we conclude that the Examiner erred in rejecting claim 1.

DECISION

We reverse the Examiner's decision rejecting claim 1.

TIME PERIOD FOR RESPONSE

Requests for extensions of time in this *ex parte* reexamination proceeding are governed by 37 C.F.R. § 1.550(c). *See* 37 C.F.R. § 41.50(f).

REVERSED

Appeal 2014-000060
Reexamination Control 90/011,861
Patent US 6,700,602 B1

msc

Patent Owner:

GAZDZINSKI & ASSOCIATES, PC
16644 WEST BERNARDO DRIVE
SUITE 201
SAN DIEGO CA 92127

Litigation Search Report CRU 3999

Reexam Control No. 90/011,681

TO: Stephen Ralis
Location: CRU
Art Unit: 3992
Date: 07/28/2014

From: Patricia Volpe
Location: CRU 3999
MDE 4B21
Phone: (571) 272-6825
Patricia.volpe@uspto.gov

Search Notes

Litigation search for U.S. Patent Number: **6,700,602**

- 1) I performed a KeyCite Search in Westlaw, which retrieves all history on the patent including any litigation.
- 2) I performed a search on the patent in Lexis CourtLink for any open dockets or closed cases.
- 3) I performed a search in Lexis in the Federal Courts and Administrative Materials databases for any cases found.
- 4) I performed a search in Lexis in the IP Journal and Periodicals database for any articles on the patent.
- 5) I performed a search in Lexis in the news databases for any articles about the patent or any articles about litigation on this patent.

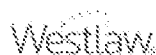

Date of Printing: Jul 28, 2014

KEYCITE**© US PAT 6700602 SUBWAY TV MEDIA SYSTEM, (Mar 02, 2004)****History****Direct History**

=> 1 **SUBWAY TV MEDIA SYSTEM**, US PAT 6700602, 2004 WL 380060 (U.S. PTO Utility Mar 02, 2004)

Patent Family

2 SUBWAY TV MEDIA SYSTEM E.G. FOR PUBLIC SERVICE MESSAGE DISPLAY HAS SEVERAL TV MONITORS MOUNTED AT INTERVALS ALONG CARS AT JUNCTION OF SIDEWALL AND CEILING WITH CENTRAL VIDEO SIGNAL SOURCE CONNECTED TO VIDEO MONITORS AND PROGRAMS OF SHORT DURATION ARE PLAYED AND DISPLAYED ON MONITORS, Derwent World Patents Legal 1998-610758+

Patent Status Files

.. Request for Re-Examination, (OG DATE: Oct 04, 2011)

Prior Art (Coverage Begins 1976)

- © 4 AIRCRAFT PASSENGER ENTERTAINMENT SYSTEM, US PAT 4352124 Assignee: Bell & Howell Company, (U.S. PTO Utility 1982)
- © 5 AIRCRAFT PASSENGER TELEVISION SYSTEM, US PAT 4647980 Assignee: Aviation Entertainment Corporation, (U.S. PTO Utility 1987)
- © 6 AUTOMATED MERCHANDISING SYSTEM, US PAT 4073368 (U.S. PTO Utility 1978)
- © 7 AUTOMATIC ADVERTISING STATION ANNOUNCING SYSTEM AND METHOD, US PAT 1894684 (U.S. PTO Utility 1933)
- © 8 BILLBOARD DEVICE, US PAT 5229910 Assignee: Abisare Co., Ltd., (U.S. PTO Utility 1993)
- © 9 DEVICE FOR INTERFACING A CD-ROM PLAYER TO AN ENTERTAINMENT OR INFORMATION NETWORK AND A NETWORK INCLUDING SUCH DEVICE, US PAT 5666291 Assignee: Sony Corporation; Sony Trans Com Inc., (U.S. PTO Utility 1997)
- © 10 DISPLAY APPARATUS FOR VEHICLE, US PAT 5059957 Assignee: Nissan Motor Company, Limited, (U.S. PTO Utility 1991)
- © 11 DISPLAY DEVICE, US PAT 5463827 Assignee: Hanover Displays Limited, (U.S. PTO Utility 1995)
- © 12 OVERHEAD SUPPORT SYSTEM FOR TV MONITORS, US PAT 5009384 Assignee: Inter-Link Communications Inc., (U.S. PTO Utility 1991)

© 2014 Thomson Reuters. All rights reserved.

- © 13 PROJECTION STATION, US PAT 3457006Assignee: BELL + HOWELL COMPANY, (U.S. PTO Utility 1969)
- © 14 REAR SCREEN VIDEO PROJECTION SYSTEM FOR AIRCRAFT PASSENGER ENTERTAINMENT, US PAT 5123728Assignee: Sony Trans Com, Inc., (U.S. PTO Utility 1992)
- © 15 SYSTEM AND METHOD FOR PROCESSING PASSENGER SERVICE SYSTEM INFORMATION, US PAT 5854591Assignee: Sony Trans Com, Inc.; Sony Corporation, (U.S. PTO Utility 1998)
- © 16 SYSTEM AND METHOD FOR SECURING A REMOVABLE SEAT ELECTRONICS UNIT WITHOUT DETACHMENT OF THE COMMUNICATION CABLE, US PAT 6038426Assignee: Sony Corporation; Sony Trans Com, Inc., (U.S. PTO Utility 2000)
- © 17 TAXICAB ADVERTISING DEVICE, US PAT 3182550 (U.S. PTO Utility 1965)
- © 18 TIMED ADVERTISING IN ELEVATORS AND OTHER SHUTTLES, US PAT 5606154Assignee: Otis Elevator Company, (U.S. PTO Utility 1997)
- © 19 VIDEO GAME APPARATUS INTEGRAL WITH AIRPLANE PASSENGER SEAT TRAY, US PAT 4630821Assignee: Aero-Vision Systems, Inc., (U.S. PTO Utility 1986)

© 2014 Thomson Reuters. All rights reserved.

Single Search - with Terms and Connectors

Enter keywords - Search multiple dockets & documents Info

 [Search](#) > [Patent Search](#) > Searching

Patent Search 6700602 7/28/2014

No cases found.

(Charges for search still apply)



UNITED STATES PATENT AND TRADEMARK OFFICE

UNITED STATES DEPARTMENT OF COMMERCE
United States Patent and Trademark Office
Address: COMMISSIONER FOR PATENTS
P.O. Box 1450
Alexandria, Virginia 22313-1450
www.uspto.gov

APPLICATION NO.	FILING DATE	FIRST NAMED INVENTOR	ATTORNEY DOCKET NO.	CONFIRMATION NO.
90/011,861	08/16/2011	6700602	BLAIR.001A	3736
27299	7590	01/05/2015	EXAMINER	
GAZDZINSKI & ASSOCIATES, PC 16644 WEST BERNARDO DRIVE SUITE 201 SAN DIEGO, CA 92127			RALIS, STEPHEN J	
			ART UNIT	PAPER NUMBER
			3992	
			MAIL DATE	DELIVERY MODE
			01/05/2015	PAPER

Please find below and/or attached an Office communication concerning this application or proceeding.

The time period for reply, if any, is set in the attached communication.

Notice of Intent to Issue Ex Parte Reexamination Certificate	Control No.	Patent Under Reexamination	
	90/011,861	6700602	
	Examiner	Art Unit	AIA (First Inventor to File) Status
	Stephen J. Ralis	3992	No

-- The MAILING DATE of this communication appears on the cover sheet with the correspondence address --

1. Prosecution on the merits is (or remains) closed in this *ex parte* reexamination proceeding. This proceeding is subject to reopening at the initiative of the Office or upon petition. Cf. 37 CFR 1.313(a). A Certificate will be issued in view of
 - (a) Patent owner's communication(s) filed: _____.
 - (b) Patent owner's failure to file an appropriate timely response to the Office action mailed: _____.
 - (c) Patent owner's failure to timely file an Appeal Brief (37 CFR 41.31).
 - (d) The decision on appeal by the Board of Patent Appeals and Interferences Court dated 30 June 2014
 - (e) Other: _____.
2. The Reexamination Certificate will indicate the following:
 - (a) Change in the Specification: Yes No
 - (b) Change in the Drawing(s): Yes No
 - (c) Status of the Claim(s):
 - (1) Patent claim(s) confirmed: 1.
 - (2) Patent claim(s) amended (including dependent on amended claim(s)): _____
 - (3) Patent claim(s) canceled: _____.
 - (4) Newly presented claim(s) patentable: 8-18,20-30.
 - (5) Newly presented canceled claims: 19.
 - (6) Patent claim(s) previously currently disclaimed: _____
 - (7) Patent claim(s) not subject to reexamination: 2-7.
3. A declaration(s)/affidavit(s) under **37 CFR 1.130(b)** was/were filed on _____.
4. Note the attached statement of reasons for patentability and/or confirmation. Any comments considered necessary by patent owner regarding reasons for patentability and/or confirmation must be submitted promptly to avoid processing delays. Such submission(s) should be labeled: "Comments On Statement of Reasons for Patentability and/or Confirmation."
5. Note attached NOTICE OF REFERENCES CITED (PTO-892).
6. Note attached LIST OF REFERENCES CITED (PTO/SB/08 or PTO/SB/08 substitute).
7. The drawing correction request filed on _____ is: approved disapproved.
8. Acknowledgment is made of the priority claim under 35 U.S.C. § 119(a)-(d) or (f).
 - a) All b) Some* c) None of the certified copies have
 - been received.
 - not been received.
 - been filed in Application No. _____.
 - been filed in reexamination Control No. _____.
 - been received by the International Bureau in PCT Application No. _____.

* Certified copies not received: _____.
9. Note attached Examiner's Amendment.
10. Note attached Interview Summary (PTO-474).
11. Other: _____.

All correspondence relating to this reexamination proceeding should be directed to the **Central Reexamination Unit** at the mail, FAX, or hand-carry addresses given at the end of this Office action.

	/Stephen J. Ralis/ Primary Examiner, Art Unit 3992
--	---

cc: Requester (if third party requester)

NOTICE OF INTENT TO ISSUE REEXAMINATION CERTIFICATE

1. The present reexamination is being conducted under the pre-AIA first to invent provisions.

I. Pertinent Prosecution History

2. On 16 August 2011, a Patent Owner (“Owner”) filed an *ex parte* reexamination request (“2011 Request”) in reexamination Control No. 90/011,861 proceedings (“’11861 Proceedings”) for claim 1 of United States Patent Number 6,700,602 (“’602 patent”).

3. On 29 September 2011, the Office mailed an Order granting the *ex parte* reexamination of claim 1 of the ‘602 patent (“2011 Order”) in the ‘11861 Proceedings.

4. The Office issued a non-Final Office action on 11 January 2012 in the (“2012 Non Final Office Action”) rejecting claim 1 of the ‘602 patent.

5. On 09 March 2012, Owner filed a “Response to Office Action” in Ex Parte Re-Examination (“March 2012 PO Response”) providing new claims 8-30.

6. The Office issued a Final Office action on 25 April 2012 (“2012 Final Office Action”) maintaining the rejection of claim 1 and rejecting new claims 8-30 of the ‘602 patent.

7. On 12 June 2012, the Office and Owner had an interview discussing the 2012 Final Office Action (“June 2012 Int Summary”).

8. On 25 June 2012, Owner filed a timely “Response to Office Action” (“June 2012 PO Response”) providing amendments to claims 8, 9, 15 and 20-23 and canceling claim 19.

Art Unit: 3992

9. The Office issued an Advisory Action on 16 January 2013 ("2013 Adv Action") entering the proposed amendments to claims 8, 9, 15 and 20-23, and canceling of claim 19, while deeming new claims 8-18 and 20-30 as patentable and maintaining the rejection of claim 1.

10. On 18 January 2013, Owner filed a "Notice of Appeal" under 35 U.S.C. 134 ("Notice of Appeal").

11. On 18 March 2013, Owner filed an Appeal Brief under 35 U.S.C. 134 ("App. Br.") and a petition to revive under 37 CFR § 1.137(b) ("2013 PO Petition").

12. The Office issued a Petition Decision on 24 June 2013 ("2013 Petition Decision") granting the revival of the '11861 Proceedings.

13. The Office issued an Examiner's Answer on 10 July 2013 ("Ans.") under 37 CFR § 41.39.

14. On 30 June 2014, the Patent Trial and Appeal Board issued a decision ("2014 Board Decision") reversing the Examiner's decision rejecting claim 1. (See Board Decision of Appeal 2014-000060 pp. 4-7).

II. Claim Status

15. The status of the claims is as follows:

Claim 1 (Original, rejected and reversed)

Claims 2-7 (Original and not under reexamination)

Claims 8-18, 20-30 (New and Allowed)

Claim 19 (Canceled).

Art Unit: 3992

STATEMENT OF REASONS FOR PATENTABILITY AND/OR CONFIRMATION

The following is an examiner's statement of reasons for patentability and/or confirmation of the claims found patentable in this reexamination proceeding: The prior art of record clearly teaches a subway car for mass transportation having a video display system with each of a plurality of monitors being located in a transitional wall portion between the ceiling and side wall of the subway car (see *Minesaki* (Japanese. Publication No. JP 63-125984 of Japanese Application No. JP 61-272668), *Amano et al.* (Japanese. Publication No. JP 02-23985 A), *Maekawa et al.* (Japanese. Publication No. JP 04-160991 A) and *Shinagawa et al.* (Japanese. Publication No. JP 04-160991 A) alone, or in various combinations).

However, with respect to the limitations of claim 1, the Board finds that the prior art of *Minesaki* fails to teach the limitation of “*each of said monitor being mounted at the junction of a sidewall and ceiling*” as recited in claim 1. (2014 Board Decision p. 4-5). Similarly, with respect to the limitations of claim 1, the Board finds that the prior art of *Maekawa et al.* and *Amano et al.*, alone or in combination, fails to teach the limitation of “*the screen of the monitor substantially flushed with the adjacent wall surface structure of the car*” as recited in claim 1. (2014 Board Decision p. 5-7)

With respect to the limitation of independent claims 8 and 21, the Examiner finds that the prior art of record does not teach *a plurality of transparent cover units* that cover the video display monitors in which *each of the transparent cover units being either flush or substantially flushed with the adjacent transitional wall portion.* Furthermore, with respect to the limitation of independent claim 15, the prior art of record does not teach *a back lit panel disposed on the transitional segment disposed adjacent the ceiling and a respective wall.*

Art Unit: 3992

Therefore, allowance of claim 1 is indicated because the prior art of *Minesaki, Maekawa et al.* and *Amano et al.* fail to teach or fairly suggests a subway car for mass transportation having a video display system, with all of the limitations of independent claim 1, particularly at least the limitations of “*each of said monitor being mounted at the junction of a sidewall and ceiling*” and “*the screen of the monitor substantially flushed with the adjacent wall surface structure of the car*” in combination with the apparatus limitations as set forth in the claim.

Allowance of claims 8-14 and 21-30 are indicated because none of the prior art of record teaches or fairly suggests a subway car for mass transportation having a video display system, with all of the limitations of independent claims 8 and 21, particularly at least the limitations of providing *a plurality of transparent cover units* that cover the video display monitors in which *each of the transparent cover units being either flush or substantially flushed with the adjacent transitional wall portion* in combination with the apparatus limitations as set forth in the claims.

Claims 9-14 and 22-30 are allowable at least because they depend from an allowable independent claim.

Similarly, allowance of claims 15-18 and 20 are indicated because none of the prior art of record teaches or fairly suggests a subway car for mass transportation having a video display system, with all of the limitations of independent claim 15, particularly at least the limitations of providing *a back lit panel disposed on the transitional segment disposed adjacent the ceiling and a respective wall* in combination with the apparatus limitations as set forth in the claims. Claims 16-18 and 20 are allowable at least because they depend from an allowable independent claim.

Any comments considered necessary by PATENT OWNER regarding the above statement must be submitted promptly to avoid processing delays. Such submission by the

Application/Control Number: 90/011,861

Page 6

Art Unit: 3992

patent owner should be labeled: "Comments on Statement of Reasons for Patentability and/or Confirmation" and will be placed in the reexamination file.

Art Unit: 3992

Conclusion

All correspondence relating to this *ex parte* reexamination proceeding should be directed:

By Mail to: Mail Stop *Ex Parte* Reexam
 Attn: Central Reexamination Unit
 Commissioner of Patents
 United States Patent & Trademark Office
 P.O. Box 1450
 Alexandria, VA 22313-1450

By FAX to: (571) 273-9900
 Central Reexamination Unit

By hand: Customer Service Window
 Randolph Building
 401 Dulany St.
 Alexandria, VA 22314

By EFS-Web:

Registered users of EFS-Web may alternatively submit such correspondence via the electronic filing system EFS-Web, at

<https://efs.uspto.gov/efile/myportal/efs-registered>

EFS-Web offers the benefit of quick submission to the particular area of the Office that needs to act on the correspondence. Also, EFS-Web submissions are "soft scanned" (i.e., electronically uploaded) directly into the official file for the reexamination proceeding, which offers parties the opportunity to review the content of their submissions after the "soft scanning" process is complete.

Art Unit: 3992

Any inquiry concerning this communication or earlier communications from the examiner, or as to the status of this proceeding, should be directed to the Central Reexamination Unit at telephone number (571) 272-7705.

/Stephen J. Ralis/
Primary Examiner, Art Unit 3992

Conferees:
/Luke S. Wassum/
Primary Examiner, Art Unit 3992

/Sudhanshu C Pathak/
SPRS, Art Unit 3992

SJR
December 12, 2014

UNITED STATES PATENT AND TRADEMARK OFFICE

UNITED STATES DEPARTMENT OF COMMERCE
United States Patent and Trademark Office
 Address: COMMISSIONER FOR PATENTS
 P.O. Box 1450
 Alexandria, Virginia 22313-1450
 www.uspto.gov

BIB DATA SHEET
CONFIRMATION NO. 3736

SERIAL NUMBER	FILING or 371(c) DATE	CLASS	GROUP ART UNIT	ATTORNEY DOCKET NO.	
90/011,861	08/16/2011	348	3992	BLAIR.001A	
APPLICANTS INVENTORS 6700602, Residence Not Provided; SCOTT BLAIR, TORONTO, CANADA; PETER J. GUTIERREZ III, SAN DIEGO, CA;					
** CONTINUING DATA ***** This application is a REX of 09/423,284 02/22/2000 PAT 6700602 which is a 371 of PCT/CA98/00439 05/06/1998 which claims benefit of 60/045,811 05/07/1997					
** FOREIGN APPLICATIONS *****					
** IF REQUIRED, FOREIGN FILING LICENSE GRANTED **					
Foreign Priority claimed <input type="checkbox"/> Yes <input checked="" type="checkbox"/> No 35 USC 119(a-d) conditions met <input type="checkbox"/> Yes <input checked="" type="checkbox"/> No Verified and Acknowledged <u>/STEPHEN J RALIS/</u> Examiner's Signature	<input type="checkbox"/> Met after Allowance Initials _____	STATE OR COUNTRY	SHEETS DRAWINGS	TOTAL CLAIMS 7	INDEPENDENT CLAIMS 1
ADDRESS GAZDZINSKI & ASSOCIATES, PC 16644 WEST BERNARDO DRIVE SUITE 201 SAN DIEGO, CA 92127 UNITED STATES					
TITLE SUBWAY TV MEDIA SYSTEM					
FILING FEE RECEIVED 2520	FEES: Authority has been given in Paper No. _____ to charge/credit DEPOSIT ACCOUNT No. _____ for following:		<input type="checkbox"/> All Fees		<input type="checkbox"/> 1.16 Fees (Filing)
			<input type="checkbox"/> 1.17 Fees (Processing Ext. of time)		<input type="checkbox"/> 1.18 Fees (Issue)
			<input type="checkbox"/> Other _____		<input type="checkbox"/> Credit

Search Notes 	Application/Control No. 90011861	Applicant(s)/Patent Under Reexamination 6700602
	Examiner STEPHEN RALIS	Art Unit 3992

CPC- SEARCHED		
Symbol	Date	Examiner

CPC COMBINATION SETS - SEARCHED		
Symbol	Date	Examiner

US CLASSIFICATION SEARCHED			
Class	Subclass	Date	Examiner

SEARCH NOTES		
Search Notes	Date	Examiner
Reviewed proposed prior art and patent prosecution history.	9/23/2011	SR
Text Searching Strategies (see EAST notes)	9/26/2011	SR
Reviewed proposed prior art and patent prosecution history.	12/23/2011	SR
Reviewed proposed prior art and patent prosecution history.	4/9/2012	SR

INTERFERENCE SEARCH			
US Class/ CPC Symbol	US Subclass / CPC Group	Date	Examiner

--	--

Issue Classification 	Application/Control No. 90011861	Applicant(s)/Patent Under Reexamination 6700602
	Examiner STEPHEN J RALIS	Art Unit 3992

<input type="checkbox"/> Claims renumbered in the same order as presented by applicant																<input type="checkbox"/> CPA		<input type="checkbox"/> T.D.		<input type="checkbox"/> R.1.47	
Final	Original	Final	Original	Final	Original	Final	Original	Final	Original	Final	Original	Final	Original	Final	Original						
1	1	17	17																		
2	2	18	18																		
3	3		19																		
4	4	19	20																		
5	5	20	21																		
6	6	21	22																		
7	7	22	23																		
8	8	23	24																		
9	9	24	25																		
10	10	25	26																		
11	11	26	27																		
12	12	27	28																		
13	13	28	29																		
14	14	29	30																		
15	15																				
16	16																				

NONE		Total Claims Allowed:	
		29	
(Assistant Examiner)	(Date)	O.G. Print Claim(s)	O.G. Print Figure
/STEPHEN J RALIS/ Primary Examiner. Art Unit 3992	12/12/2014	1	2
(Primary Examiner)	(Date)		

Reexamination 	Application/Control No. 90011861	Applicant(s)/Patent Under Reexamination 6700602
	Certificate Date	Certificate Number C1

Requester Correspondence Address:	<input checked="" type="checkbox"/> Patent Owner	<input type="checkbox"/> Third Party
--	---	---

GAZDZINSKI & ASSOCIATES, PC
16644 WEST BERNARDO DRIVE
SUITE 201
SAN DIEGO, CA 92127

LITIGATION REVIEW <input checked="" type="checkbox"/>	SR (examiner initials)	07/28/2014 (date)
Case Name		Director Initials
No Litigation is currently pending.		

COPENDING OFFICE PROCEEDINGS	
TYPE OF PROCEEDING	NUMBER
1. No copending proceedings.-	

--	--



US006700602C1

(12) **EX PARTE REEXAMINATION CERTIFICATE** (10487th)
United States Patent
Blair

(10) **Number:** **US 6,700,602 C1**
(45) **Certificate Issued:** **Jan. 29, 2015**

(54) **SUBWAY TV MEDIA SYSTEM**

(76) Inventor: **Scott Blair**, Toronto (CA)

Reexamination Request:

No. 90/011,861, Aug. 16, 2011

Reexamination Certificate for:

Patent No.: **6,700,602**
Issued: **Mar. 2, 2004**
Appl. No.: **09/423,284**
Filed: **Feb. 22, 2000**

(21) Appl. No.: **90/011,861**

(22) PCT Filed: **May 6, 1998**

(86) PCT No.: **PCT/CA98/00439**

§ 371 (c)(1),
(2), (4) Date: **Feb. 22, 2000**

(87) PCT Pub. No.: **WO98/51081**

PCT Pub. Date: **Nov. 12, 1998**

Related U.S. Application Data

(60) Provisional application No. 60/045,811, filed on May 7, 1997.

(51) **Int. Cl.**

H04N 7/18 (2006.01)

H04N 5/64 (2006.01)

(52) **U.S. Cl.**

USPC **348/61; 348/837**

(58) **Field of Classification Search**

None

See application file for complete search history.

(56)

References Cited

To view the complete listing of prior art documents cited during the proceeding for Reexamination Control Number 90/011,861, please refer to the USPTO's public Patent Application Information Retrieval (PAIR) system under the Display References tab.

Primary Examiner — Stephen J Ralis

(57)

ABSTRACT

A television system for subway cars (10) includes a plurality of TV monitors (22) mounted at intervals along the cars (10), at the junction of the sidewall and the ceiling, and a central video signal source unit (23) such as a video tape player, video disk player, computer-based digital video recorder or television receiver, connected to the video monitors (22). Programs of short duration, e.g. 5-15 minutes, matching the average length of a subway ride, and comprising advertising messages, news bytes and the like are played and displayed in the monitors repeatedly during the subway ride.

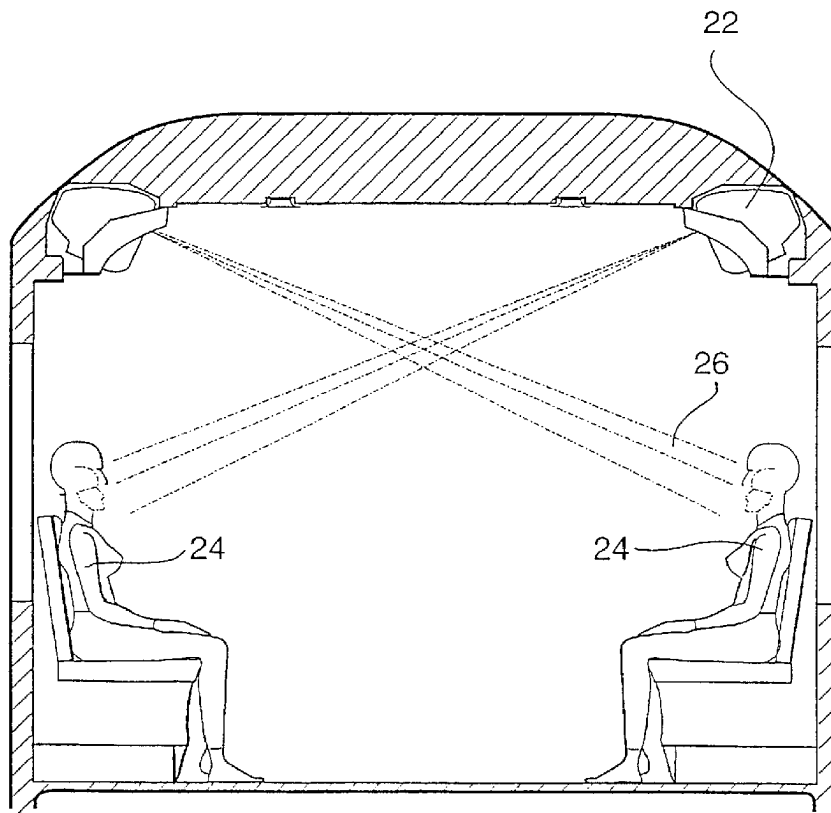

1
EX PARTE
REEXAMINATION CERTIFICATE
ISSUED UNDER 35 U.S.C. 307

THE PATENT IS HEREBY AMENDED AS
INDICATED BELOW.

Matter enclosed in heavy brackets [] appeared in the patent, but has been deleted and is no longer a part of the patent; matter printed in italics indicates additions made to the patent.

AS A RESULT OF REEXAMINATION, IT HAS BEEN DETERMINED THAT:

The patentability of claim 1 is confirmed.

New claims 8-29 are added and determined to be patentable.

Claims 2-7 were not reexamined.

8. *A subway car for mass transportation, comprising: a video display system comprising a plurality of video display monitors each having a video screen, and a video signal source unit operatively connected to said video display monitors; a plurality of transparent cover units that cover respective ones of the video display monitors; a pair of longitudinal opposed sidewalls, each of the sidewalls comprising a transitional wall portion at the junction of the sidewall and ceiling that is directed obliquely downwardly; and a ceiling adjoining the sidewalls; wherein the monitors are spaced along the length of the car on opposed sides thereof, the monitors being disposed within the transitional wall portion such that the transparent cover units covering respective ones of the video display monitors are substantially flush with the adjacent surface structure of the transitional wall portion, wherein the monitors are also directed obliquely downwardly toward the car seats so that each video screen is readily visible to passengers in the subway car.*

9. *The subway car of claim 8, wherein the plurality of transparent cover units are rigid and are further configured to protect the video display monitor.*

10. *The subway car of claim 9, wherein the video display monitor is disposed within the transitional wall portion such that it contains no visible edges or protuberances.*

11. *The subway car of claim 8, further comprising a back lit panel disposed on the transitional wall portion, the back lit panel disposed adjacent the video screen of the video display monitor.*

12. *The subway car of claim 8, wherein the video display monitors are each enclosed within an enclosure.*

13. *The subway car of claim 12, wherein the enclosure is secured to a structural member disposed between an inner wall and an outer structural shell of the subway car.*

14. *The subway car of claim 13, wherein the enclosure and a respective video display monitor is removable from the subway car as a unit.*

15. *A subway car for mass transportation including longitudinal opposed sidewalls that further comprise a transitional segment and a ceiling adjoining the sidewalls with the transitional segment disposed at the junction of the sidewall and the ceiling, the subway car further comprising:*

2

*a video display system comprising:
a plurality of video display monitors each having a video screen; and
a video signal source unit operatively connected to said video display monitors;*

wherein said video display monitors are spaced along the length of the car on opposing sides of the subway, each of the video display monitors being mounted within the transitional segment, with the video screen of each video display monitor being substantially contiguous with an exterior surface of said transitional segment, said video screen being directed obliquely downwardly toward the car seats so that each video screen is readily visible to passengers in the subway car; and

a back lit panel disposed on the transitional segment disposed adjacent the ceiling and a respective sidewall.

16. *The subway car of claim 15, wherein an external surface of the longitudinal opposed sidewall, the exterior surface of said transitional segment and an external surface of the ceiling comprise a blended contour.*

17. *The subway car of claim 15, wherein the video signal source unit is configured to display a series of short messages in sequence on said plurality of video display monitors.*

18. *The subway car of claim 17, wherein the series of short messages comprise advertising content, said advertising content providing an additional source of revenue for the operator of the subway car.*

19. *The subway car of claim 15, wherein the back lit panel is disposed adjacent the video screen of the video display monitor.*

20. *A subway car for mass transportation including longitudinal opposed sidewalls, a ceiling adjoining the sidewalls, a video display system comprising a plurality of video display monitors each having a video screen, and a video signal source unit operatively connected to said monitors,*

said monitors being spaced along the length of the car on opposed sides thereof, each of said monitors being mounted at the junction of the sidewall and ceiling and further being covered with a transparent cover unit, with the transparent cover unit flushed with the adjacent wall surface structure of the car, and with the monitors directed obliquely downwardly toward the car seats, so that each video screen is readily visible to passengers in the subway car.

21. *The subway car of claim 20, wherein the transparent cover unit for a respective video display monitor is rigid and is further configured to protect the video display monitor.*

22. *The subway car of claim 20, wherein the transparent cover unit is flushed within the adjacent wall structure such that it contains no protuberances.*

23. *The subway car of claim 20, further comprising a back lit panel disposed on the adjacent wall surface structure of the car.*

24. *The subway car of claim 20, wherein the video display monitors are each enclosed within an enclosure.*

25. *The subway car of claim 24, wherein the enclosure is secured to a structural member disposed between an inner wall and an outer structural shell of the subway car.*

26. *The subway car of claim 25, wherein the enclosure and a respective video display monitor is removable from the subway car as a unit.*

27. *The subway car of claim 20, wherein an external surface of the longitudinal opposed sidewalls, the adjacent wall surface structure and an external surface of the ceiling comprise a blended contour.*

28. The subway car of claim 20, wherein the video signal source unit is configured to display a series of short messages in sequence on said plurality of video display monitors.

29. The subway car of claim 28, wherein the series of short messages comprise advertising content, said advertising content providing an additional source of revenue for the operator of the subway car. 5

* * * * *

IN THE UNITED STATES PATENT AND TRADEMARK OFFICE

Patentee : Scott Blair)
 Patent No. : 6,700,602 – Issued 03/02/04)
 Control No. : 90/011,861)
 Filed : August 16, 2011)
 For : **SUBWAY TV MEDIA SYSTEM**)
 Examiner : Stephen Ralis)
 Group Art Unit: 3992)



27299

PATENT TRADEMARK OFFICE

CERTIFICATE OF ELECTRONIC (EFS-WEB) TRANSMISSION

I hereby certify that this correspondence is being transmitted via the Office electronic filing system in accordance with 37 C.F.R. § 1.8(a)(i)(C) from the Pacific Time Zone of the United States on the local date shown below.

Dated: February 17, 2015

By: Peter J. Gutierrez, III
Peter J. Gutierrez, III, Reg. No. 56,732

TRANSMITTAL LETTER – EX PARTE REEXAMINATION

Mail Stop *Ex Parte* Reexam
Central Reexamination Unit
Commissioner for Patents
United States Patent & Trademark Office
P.O. Box 1450
Alexandria, VA 22313-1450

Sir:

Transmitted herewith in the above-entitled Ex Parte Reexamination application are the following:

- Comments on Statement of Reasons for Patentability and/or Confirmation (2 Pages).

The Commissioner is hereby authorized to charge any fees owed to Deposit Acct. No. 501423.

Respectfully submitted,

GAZDZINSKI & ASSOCIATES, PC

Dated: February 17, 2015

By: Peter J. Gutierrez, III
 Peter J. Gutierrez, III
 Registration No. 56,732
 16644 West Bernardo Drive, Suite 201
 San Diego, CA 92127
 Telephone No.: (858) 675-1670
 Facsimile No.: (858) 675-1674

IN THE UNITED STATES PATENT AND TRADEMARK OFFICE

Patentee : Scott Blair)
 Patent No. : 6,700,602 – Issued 03/02/04)
 Control No. : 90/011,861)
 Filed : August 16, 2011)
 For : **SUBWAY TV MEDIA SYSTEM**)
 Examiner : Stephen Ralis)
 Group Art Unit: 3992)



27299

PATENT TRADEMARK OFFICE

CERTIFICATE OF ELECTRONIC (EFS-WEB) TRANSMISSION

I hereby certify that this correspondence is being transmitted via the Office electronic filing system in accordance with 37 C.F.R. § 1.8(a)(i)(C) from the Pacific Time Zone of the United States on the local date shown below.

Dated: February 17, 2015

By: *Peter J. Gutierrez, III*
Peter J. Gutierrez, III, Reg. No. 56,732

5

COMMENTS ON STATEMENT OF REASONS FOR PATENTABILITY AND/OR CONFIRMATION

10

Mail Stop *Ex Parte* Reexam
Central Reexamination Unit
Commissioner for Patents
United States Patent & Trademark Office
15 P.O. Box 1450
Alexandria, VA 22313-1450

Dear Sir:

In response to the Notice of Intent to Issue Reexamination Certificate dated January 5,
20 2015 (“NIRC”), the following is provided:

Control No. : 90/011,861
Filed : August 16, 2011

COMMENTS

Patent Owner hereby acknowledges the Statement of Reasons for Patentability and/or Confirmation ("Reasons") given by the Examiner in the NIRC. Moreover, Patent Owner respectfully notes that the Examiner has provided one or more personal opinions as to the teachings of the prior art within the NIRC. Patent Owner in no way acquiesces to, nor necessarily agrees with, the Examiner's opinions. Patent Owner respectfully notes that there may be reasons for allowance that have not been specifically cited, and which may apply to various ones of the allowed claim(s), in addition to or instead of the cited Reasons given by the Examiner.

Patent Owner respectfully submits that notwithstanding the foregoing Reasons, it is believed that each of the allowed claims is patentable in its own right and/or for reasons raised during reexamination and/or explained in the specification of this application.

Other Remarks

If the Examiner has any questions or comments which may be resolved over the telephone, he is respectfully requested to call the undersigned at (858) 675-1670.

Respectfully submitted,

GAZDZINSKI & ASSOCIATES, PC

Dated: February 17, 2015

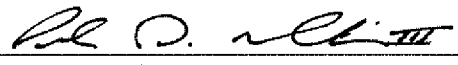
By: 
Peter J. Gutierrez, III
Registration No. 56,732
16644 West Bernardo Drive, Suite 201
San Diego, CA 92127
Telephone No.: (858) 675-1670
Facsimile No.: (858) 675-1674

Electronic Acknowledgement Receipt

EFS ID:	21520394
Application Number:	90011861
International Application Number:	
Confirmation Number:	3736
Title of Invention:	SUBWAY TV MEDIA SYSTEM
First Named Inventor/Applicant Name:	6700602
Customer Number:	27299
Filer:	Peter John Gutierrez III
Filer Authorized By:	
Attorney Docket Number:	BLAIR.001A
Receipt Date:	17-FEB-2015
Filing Date:	16-AUG-2011
Time Stamp:	17:44:38
Application Type:	Reexam (Patent Owner)

Payment information:

Submitted with Payment	no
------------------------	----

File Listing:

Document Number	Document Description	File Name	File Size(Bytes)/ Message Digest	Multi Part /.zip	Pages (if appl.)
1	Reexam Miscellaneous Incoming Letter	Transmittal.pdf	31788 <small>b154bd94c55f90b0ea70ad4c24630d4eb375456f</small>	no	1

Warnings:

Information:

2	Reexam Miscellaneous Incoming Letter	Comments_on_NIRC.pdf	52084	no	2
			2df6ef3f1f5c31a8aed5904db3a935affd8f20 of		

Warnings:

Information:

Total Files Size (in bytes):	83872
-------------------------------------	-------

This Acknowledgement Receipt evidences receipt on the noted date by the USPTO of the indicated documents, characterized by the applicant, and including page counts, where applicable. It serves as evidence of receipt similar to a Post Card, as described in MPEP 503.

New Applications Under 35 U.S.C. 111

If a new application is being filed and the application includes the necessary components for a filing date (see 37 CFR 1.53(b)-(d) and MPEP 506), a Filing Receipt (37 CFR 1.54) will be issued in due course and the date shown on this Acknowledgement Receipt will establish the filing date of the application.

National Stage of an International Application under 35 U.S.C. 371

If a timely submission to enter the national stage of an international application is compliant with the conditions of 35 U.S.C. 371 and other applicable requirements a Form PCT/DO/EO/903 indicating acceptance of the application as a national stage submission under 35 U.S.C. 371 will be issued in addition to the Filing Receipt, in due course.

New International Application Filed with the USPTO as a Receiving Office

If a new international application is being filed and the international application includes the necessary components for an international filing date (see PCT Article 11 and MPEP 1810), a Notification of the International Application Number and of the International Filing Date (Form PCT/RO/105) will be issued in due course, subject to prescriptions concerning national security, and the date shown on this Acknowledgement Receipt will establish the international filing date of the application.