

EXHIBIT 2006

2761960.txt

1

1
2
3
4
5
6
7
8
9
10
11
12
13
14
15
16
17
18
19
20
21

UNITED STATES PATENT AND TRADEMARK OFFICE
BEFORE THE PATENT TRIAL AND APPEAL BOARD
Case No. IPR2017-00117

- - - - -x

KAWASAKI RAIL CAR, INC.

Petitioner,

v.

SCOTT BLAIR,

Patent Owner.

- - - - -x

November 28, 2017
11:24 a.m.

VIDEOTAPED DEPOSITION of LOWELL
MALO, an Expert on behalf of
Petitioner, taken by Patent Owner,
held at the offices of Andrews, Kurth
& Kenyon LLP, One Broadway, New York,

2761960.txt

22 New York, before Kathleen Piazza
23 Luongo, a Notary Public of the State
24 of New York.
25

2

1

2 A P P E A R A N C E S :

3

4 ANDREWS, KURTH & KENYON LLP

5 One Broadway

6 10th Floor

7 New York, New York 10004-1007

8 Attorneys for Petitioner and

9 Expert Witness

10 BY: ZAED M. BILLAH, ESQ.

11 zbillah@andrewskurthkenyon.com

12 -and-

13 ARMIN GHIAM, ESQ.

14 aghiam@andrewskurthkenyon.com

15

16 MEREDITH & KEYHANI, PLLC

17 205 Main Street

2761960.txt

18 East Aurora, New York 14052
19 Attorneys for Patent Owner
20 BY: DARIUS KEYHANI, ESQ.
21 dkeyhani@meredithkeyhani.com

22
23 ALSO PRESENT:
24 Stephen Kent, Videographer
25

3

1

2 S T I P U L A T I O N S

3

4 IT IS HEREBY STIPULATED AND AGREED
5 by and between the attorneys for the
6 respective parties hereto that the filing
7 and sealing and be and the same are hereby
8 waived.

9 IT IS FURTHER STIPULATED AND AGREED
10 that all objections, except as to form of
11 the question, shall be reserved to the time
12 of the trial.

13 IT IS FURTHER STIPULATED AND AGREED

2761960.txt

14 that the within examination may be signed
15 before any notary public with the same
16 force and effect as though signed and sworn
17 to before the Court.

18
19
20
21
22
23
24
25

4

1 LOWELL MALO
2 THE VIDEOGRAPHER: Good 11:25:29
3 morning. 11:25:29
4 We are going on the record at 11:25:30
5 11:24 a.m. on November 28, 2017. 11:25:32
6 Please note that the 11:25:38
7 microphones are sensitive and may 11:25:40
8 pick up whispering, private 11:25:42
9 conversations and cellular 11:25:44
10 interference. 11:25:48

2761960.txt

11 Please turn off all cell phones 11:25:48
12 or place them away from the 11:25:50
13 microphones as they can interfere 11:25:52
14 with the deposition audio. 11:25:53
15 Audio and video recording will 11:25:54
16 continue to take place unless all 11:25:56
17 parties agree to go off the record. 11:25:59
18 This is media unit one of the 11:26:01
19 video-recorded deposition of Lowell 11:26:03
20 Malo in the matter of Kawasaki Rail 11:26:06
21 Car, Incorporated versus Scott Blair, 11:26:10
22 filed in the United States Patent 11:26:13
23 and Trademark Office, Case No. 11:26:15
24 IPR2017-00117. 11:26:20
25 This deposition is being held 11:26:22

5

1 LOWELL MALO
2 at Andrews Kurth & Kenyon, located at 11:26:24
3 One Broadway. 11:26:27
4 My name is Stephen Kent from 11:26:28
5 the firm Veritext, New York, and I'm 11:26:30
6 the videographer. 11:26:32
7 The court reporter is Kathleen 11:26:34

2761960.txt

8 Luongo from the firm Veritext, 11:26:36
9 New York. 11:26:38
10 I'm not authorized to 11:26:38
11 administer an oath. I'm not related 11:26:41
12 to any party in this action nor am I 11:26:43
13 financially interested in the 11:26:46
14 outcome. 11:26:48
15 Counsel and all present in the 11:26:48
16 room will now state their appearances 11:26:49
17 and affiliations for the record. 11:26:52
18 If there are any objections to 11:26:54
19 the proceeding please state them at 11:26:56
20 the time of your appearance, 11:26:58
21 beginning with the Noticing attorney. 11:26:59
22 MR. KEYHANI: Darius Keyhani of 11:27:02
23 Meredith & Keyhani on behalf of the 11:27:03
24 Patent Owner, Scott Blair. 11:27:04
25 MR. BILLAH: Zaed Billah from 11:27:06

6

1 LOWELL MALO
2 Andrews Kurth & Kenyon, representing 11:27:07
3 Petitioner, Kawasaki Rail Car, Inc. 11:27:11
4 and the witness. 11:27:15

2761960.txt

5 MR. GHIAM: Armin Ghiam on 11:27:16
6 behalf of Kawasaki Rail Car, Inc., 11:27:18
7 representing Petitioner. 11:27:20
8 THE VIDEOGRAPHER: Will the 11:27:23
9 court reporter please swear in the 11:27:25
10 witness. 11:27:26
11 L O W E L L M A L O, called as a 11:27:26
12 witness, having first been duly sworn, was 11:27:26
13 examined and testified as follows: 11:27:43
14 THE VIDEOGRAPHER: Thank you. 11:27:43
15 You may proceed. 11:27:44
16 EXAMINATION BY MR. KEYHANI: 11:27:45
17 Q. Good morning. May I call you 11:27:45
18 Dr. Malo; is that okay? 11:27:48
19 A. I'm not a doctor but you can if 11:27:49
20 you want. 11:27:51
21 Q. What would you like to be 11:27:52
22 called? 11:27:54
23 A. Just Lowell. 11:27:54
24 Q. Lowell, okay. 11:27:55
25 Lowell, can you tell us how you 11:28:05

7

1 LOWELL MALO

Page 7

2761960.txt

2 prepared for this deposition today. 11:28:08
3 MR. BILLAH: I caution the 11:28:12
4 witness not to disclose 11:28:13
5 communications with counsel. 11:28:15
6 MR. KEYHANI: You can go ahead. 11:28:18
7 MR. BILLAH: You can answer. 11:28:21
8 THE WITNESS: Pardon? 11:28:22
9 MR. BILLAH: You can answer. 11:28:24
10 THE WITNESS: Okay. 11:28:25
11 A. We read the depositions. We 11:28:26
12 read the patents. 11:28:30
13 Q. Which deposition did you read? 11:28:31
14 A. There were two of them. 11:28:33
15 Q. When you say "deposition" do 11:28:37
16 you mean transcripts or are you speaking 11:28:40
17 about something else? You said you read 11:28:41
18 two depositions. 11:28:44
19 A. Um hum, not depositions, I'm 11:28:45
20 sorry, declarations. I believe that's the 11:28:47
21 terminology. I'm not an attorney, I'm 11:28:49
22 not up on the words. 11:28:53
23 Q. No problem. 11:28:54
24 Before you proceed, can I ask 11:28:55
25 you have you been deposed before in any 11:28:56

2761960.txt

23 Q. Sure, fair enough. 11:29:49
 24 So you were involved as a 11:29:50
 25 consultant in at least two cases before? 11:29:53

9

1 LOWELL MALO

2 A. Um hum. 11:29:56
 3 Q. And how long ago was that? 11:29:56
 4 A. At least two years ago. 11:30:00
 5 Q. Two years ago? 11:30:01
 6 A. At least, yes. 11:30:02
 7 Q. So there are a few ground rules 11:30:04
 8 in a deposition -- you may know this 11:30:09
 9 already, your lawyers may have advised 11:30:11
 10 you already, but I'll share them with you 11:30:13
 11 on the record to make the process as 11:30:15
 12 smooth as possible. 11:30:17
 13 A. Um hum. 11:30:19
 14 Q. I'm going to be asking you 11:30:19
 15 questions today, obviously, you're going 11:30:21
 16 to be providing testimony, as you know, 11:30:23
 17 under oath as you are sworn in. 11:30:26
 18 A. Um hum. 11:30:29
 19 Q. This is no different than if 11:30:30

2761960.txt

20 you were testifying before the Court and 11:30:32
 21 a jury? 11:30:34
 22 A. Right. 11:30:34
 23 Q. If you don't understand my 11:30:36
 24 question just ask me to clarify, I'll be 11:30:37
 25 happy to, that's my job to do that. 11:30:40

10

1 LOWELL MALO

2 A. Um hum. 11:30:43
 3 Q. Of if there's confusion or 11:30:43
 4 there is some other problem with the 11:30:46
 5 question. 11:30:47
 6 A. Um hum. 11:30:47
 7 Q. And just let me know and I will 11:30:48
 8 assist you with that. 11:30:50
 9 Your attorneys may object from 11:30:51
 10 time to time, like they just did a moment 11:30:54
 11 ago; unless they tell you not to answer 11:30:55
 12 the question you need to answer the 11:30:58
 13 question. 11:30:59
 14 If they tell you don't answer 11:31:00
 15 the question then you can confer with 11:31:02
 16 them; but otherwise they make their 11:31:05

2761960.txt

17 objection, you answer the question and 11:31:07
 18 then we will proceed, and that's just the 11:31:09
 19 way that the process goes. 11:31:14
 20 A. Okay. 11:31:15
 21 Q. If you need a break for water 11:31:17
 22 or any other reason, just please take 11:31:20
 23 your break after you answer my question 11:31:23
 24 that was pending, obviously. 11:31:25
 25 A. Um hum. 11:31:27

11

1 LOWELL MALO
 2 Q. The rules also provide that 11:31:29
 3 you're not supposed to confer with your 11:31:31
 4 counsel during breaks regarding the 11:31:33
 5 deposition. 11:31:35
 6 A. Um hum. 11:31:36
 7 Q. Counsel may have already 11:31:36
 8 advised you of that but those are part 11:31:39
 9 of the rules. You may confer about 11:31:42
 10 lunch, just not about the testimony, no 11:31:44
 11 different than if you would be testifying 11:31:46
 12 in a courtroom. 11:31:47
 13 A. Um hum. 11:31:48

2761960.txt

14 Q. I will be providing you various 11:31:53
15 documents during the course of the 11:31:55
16 deposition that will be marked by our 11:31:58
17 court reporter; and that is the general 11:32:00
18 guidelines that I can think of. 11:32:04
19 One last point, please try not 11:32:09
20 your very best, it will happen, that 11:32:12
21 before my question is finished don't 11:32:15
22 interrupt or answer your question before 11:32:17
23 I'm finished so that we get a clear 11:32:19
24 record because she can't type two 11:32:22
25 conversations at the same time, and I 11:32:25

12

1 LOWELL MALO
2 will do my very best to listen and watch 11:32:26
3 your body language and not interrupt you 11:32:29
4 or if you're still trying to finish your 11:32:32
5 answer to a question so that question, 11:32:34
6 answer, question, answer. 11:32:37
7 Also, I know this happens in 11:32:38
8 normal conversation, but we don't want to 11:32:40
9 do that for the purposes of this 11:32:42
10 exercise. 11:32:45

2761960.txt

11 And one other point is don't 11:32:45
12 use body language to answer like yes or 11:32:47
13 no because that doesn't show up on the 11:32:52
14 transcript. Say yes or no or whatever 11:32:54
15 the answer is verbally. Okay? 11:32:55
16 A. All right. 11:32:57
17 Q. Do you have any questions for 11:32:58
18 me? 11:33:00
19 A. Not at this point. 11:33:00
20 Q. Okay. 11:33:01
21 Can you state your address for 11:33:03
22 the record. 11:33:06
23 A. 9305 River Cove Drive, River 11:33:06
24 View, Florida. 11:33:11
25 Q. And your full name, your full 11:33:12

13

1 LOWELL MALO
2 formal name for the record. 11:33:16
3 A. Loyal Leo Malo. 11:33:16
4 Q. Thank you. 11:33:19
5 What is your current position? 11:33:20
6 A. Vice President of Engineering 11:33:23
7 with Rail Plan International. 11:33:26

2761960.txt

8 THE REPORTER: I can barely 11:33:26
9 hear you. 11:33:26
10 MR. BILLAH: Speak up a little. 11:33:23
11 A. Vice President of Engineering 11:33:23
12 with Rail Plan International. 11:33:26
13 MR. KEYHANI: You may want to 11:33:35
14 pull up your microphone just a little 11:33:36
15 bit if that's helpful. Couple of 11:33:39
16 inches. 11:33:41
17 Q. What are your responsibilities 11:33:42
18 in this capacity? 11:33:44
19 A. I manage the overall 11:33:46
20 engineering activities of Rail Plan 11:33:49
21 International, including on occasions 11:33:52
22 doing some actual engineering work 11:33:54
23 myself. 11:33:57
24 Q. When you say "manage," can you 11:33:57
25 explain a little more what that entails 11:33:59

14

1 LOWELL MALO
2 in sort of categories of work perhaps. 11:34:01
3 A. Rail Plan has several different 11:34:03
4 clients, many car builders, Kawasaki, 11:34:06

2761960.txt

5 CAF, Siemens, Stadler and Alstom, and we 11:34:10
6 have various contracts with these 11:34:20
7 companies and so we assign people to do -- 11:34:21
8 to fulfill the requirements of the 11:34:24
9 contracts. 11:34:25

10 Q. So can you explain how you do 11:34:27
11 that, how you assist them with that, with 11:34:30
12 fulfilling the requirements of the 11:34:33
13 contract. 11:34:35

14 A. We'll take a look at the 11:34:36
15 requirement of the contract, we will 11:34:39
16 select the proper personnel to put on the 11:34:41
17 contract and to do the work and then we 11:34:44
18 review the output before going to the 11:34:47
19 customer. 11:34:50

20 Q. So you kind of like work in 11:34:50
21 between sort of, between the people that 11:34:53
22 work on the project and the customer? 11:34:55

23 A. For the most part, yes. 11:34:57

24 Q. For the most part? 11:34:58

25 A. Um hum. 11:35:00

2761960.txt

2 Q. Do you -- do you actually 11:35:01
3 engage in engineering activities 11:35:02
4 sometimes? 11:35:04
5 A. Yes. 11:35:04
6 Q. Can you explain, when does that 11:35:05
7 happen? 11:35:07
8 A. Um, it happens frequently. 11:35:09
9 Q. Okay. 11:35:13
10 A. Just to give guidance to the 11:35:14
11 engineers and in some cases I will 11:35:16
12 actually do the work if we're 11:35:19
13 shorthanded. 11:35:20
14 Q. Do the engineers work for you 11:35:21
15 or they work for a separate entity that 11:35:23
16 you coordinate with? 11:35:25
17 A. They work for a group within 11:35:26
18 Rail Plan. I travel a lot and I cannot 11:35:28
19 be there continuously, so there's a 11:35:31
20 separate group that regularly reports to 11:35:33
21 me and then I work out the assignments. 11:35:36
22 Q. And that's a division of your 11:35:37
23 company, the -- 11:35:39
24 A. Yes. 11:35:42
25 Q. Okay. 11:35:42

1 LOWELL MALO

2 Who are your biggest customers 11:35:43

3 right now you are working with? You 11:35:44

4 mentioned a couple, a number of them. 11:35:47

5 A. Yes. 11:35:49

6 Right now the biggest customer 11:35:49

7 would be CAF, Spanish company. 11:35:51

8 Q. Yes. 11:35:54

9 A. Alstom is a customer. We do 11:35:56

10 work with Kawasaki. We have contracts 11:35:58

11 with Stadler right now. We have -- I'm 11:36:01

12 trying to think of the other companies -- 11:36:07

13 Talgo. We do a lot of work with 11:36:09

14 different companies. 11:36:12

15 Q. What kind of work do you do, 11:36:13

16 for example, with Alstom right now? 11:36:15

17 A. With Alstom right now we do two 11:36:17

18 things, one is building the mock-ups for 11:36:21

19 the high speed trains. 11:36:24

20 Q. Oh, where are these trains 11:36:26

21 going to be going from, the high speed? 11:36:28

22 A. The high speed is going to be 11:36:30

2761960.txt

23 the replacement for the Acela up and down 11:36:32
 24 the East Coast. 11:36:36
 25 Q. I was hoping a different 11:36:36

17

1 LOWELL MALO

2 location. 11:36:37
 3 A. They will come up this way, 11:36:39
 4 too; that's Amtrak's call. 11:36:41
 5 Q. I see. 11:36:43
 6 What else do you do for Alstom, 11:36:44
 7 contract-wise? 11:36:47
 8 A. Contract-wise they have had me 11:36:50
 9 for a short time managing projects until 11:36:52
 10 they can get a replacement for me, just 11:36:56
 11 filling the gap. 11:36:59
 12 Q. How long have you been managing 11:37:00
 13 projects for them, approximately? 11:37:02
 14 A. Well, it would go back many, 11:37:03
 15 many years, but I would say since 1998. 11:37:05
 16 Q. You have been handling projects 11:37:10
 17 -- I'm sorry for interrupting you. 11:37:13
 18 A. On and off, sometimes no work 11:37:15
 19 with Alstom, sometimes work with Alstom. 11:37:17

2761960.txt

20 Like I said, we have many customers. 11:37:21

21 Q. Right. 11:37:23

22 And sometimes you manage those 11:37:23

23 projects yourself? 11:37:25

24 A. Yes, short term until they can 11:37:26

25 get a replacement. 11:37:28

18

1 LOWELL MALO

2 Q. And how long has short term 11:37:29

3 been, for example? 11:37:32

4 A. The longest contract I've had 11:37:33

5 with Alstom has been about four months. 11:37:35

6 Q. Four months? 11:37:38

7 A. Um hum. 11:37:38

8 Q. Are you working on any matters 11:37:39

9 right now with Alstom? 11:37:41

10 A. Yes. 11:37:41

11 Q. What are you working on? Is 11:37:42

12 that the speed train project? 11:37:44

13 A. No, I'm doing some work out in 11:37:46

14 California and we have a project called 11:37:48

15 Holland America and I have some 11:37:51

16 background as an ex-customer with another 11:37:54

2761960.txt

17 company I used to work for, so that means 11:37:57
18 come in, set up a proposal and then turn 11:38:00
19 the project over. 11:38:03
20 Q. I see. 11:38:04
21 And that involves what kind of 11:38:04
22 technology, that project? 11:38:07
23 A. It's complete renovation of 11:38:08
24 rail cars. 11:38:10
25 Q. The interior of rail cars? 11:38:11

19

1 LOWELL MALO
2 A. Yes, and exterior. 11:38:13
3 Q. The entire rail car? 11:38:15
4 A. Yes. 11:38:17
5 Q. Are you doing engineering work 11:38:18
6 to or are you managing engineers on that 11:38:19
7 project? 11:38:22
8 A. Both. 11:38:22
9 Q. Both? 11:38:23
10 A. Yes. 11:38:23
11 Q. Sounds like a lot of traveling. 11:38:24
12 A. It is. 11:38:26
13 Q. How about Kawasaki, what kind 11:38:28

2761960.txt

14 of work are you doing for them or with 11:38:28
15 them? 11:38:31
16 A. Okay, with Kawasaki it's 11:38:31
17 various interior components, trying to 11:38:34
18 think of some, interior panels and such 11:38:39
19 for the rail cars, interior design work 11:38:42
20 for them. 11:38:45
21 Q. Currently are you doing some of 11:38:45
22 them right now? 11:38:47
23 A. That is a little bit of a low 11:38:48
24 level right now. 11:38:50
25 Q. With Kawasaki it's just -- 11:38:51

20

1 LOWELL MALO
2 A. At a low level right now. 11:38:51
3 Q. When was the last time you had 11:38:52
4 a higher level work with them? 11:38:54
5 A. Eight months ago or so. 11:38:56
6 Q. What were you working on then? 11:38:57
7 A. Interior panels. 11:39:00
8 Q. Interior panels? 11:39:02
9 A. Yes. 11:39:03
10 Q. Are these like monitors? When 11:39:03

2761960.txt

11 you say "panels" what are you speaking 11:39:05
12 about? 11:39:07
13 A. Mainly the interior walls, 11:39:07
14 interior ceilings, the location of 11:39:09
15 displays, for example. 11:39:13
16 Q. Like display monitors? When 11:39:15
17 you see displays, like advertising 11:39:20
18 displays for example? 11:39:21
19 A. It could be, yeah. 11:39:22
20 Q. So any kind of displays? 11:39:24
21 A. Yes. 11:39:25
22 Q. What about like the chairs in 11:39:25
23 the car, stuff like that, would you be 11:39:27
24 working on that as well, or the benches, 11:39:30
25 whatever you call them? 11:39:32

21

1 LOWELL MALO
2 A. Seats. 11:39:33
3 Q. Seats, I'm sorry. 11:39:33
4 A. Not -- not recently. We have 11:39:35
5 developed complete seating systems in the 11:39:37
6 past but not this one. 11:39:40
7 Q. So you work on both the 11:39:42

2761960.txt

8 structure and interior components that 11:39:44
9 are attached to the structure? 11:39:46
10 A. Um hum. 11:39:47
11 Q. And you said right now you are 11:39:49
12 working on a low level, lower level 11:39:51
13 matters or lesser matters with Kawasaki; 11:39:53
14 what would those be, for example? 11:39:55
15 A. Right now personally I've been 11:39:57
16 not doing a whole lot for them. 11:40:00
17 Q. All right, but you're on 11:40:01
18 retainer with them? 11:40:03
19 A. I don't know how -- 11:40:04
20 Q. Well, your company is on 11:40:08
21 retainer? 11:40:08
22 A. I don't know if a retainer 11:40:10
23 exists or not. 11:40:12
24 Q. Okay. 11:40:13
25 A. But it's -- 11:40:14

22

1 LOWELL MALO
2 Q. Ongoing? 11:40:15
3 A. It's an ongoing relationship. 11:40:16
4 MR. KEYHANI: Do you want to go 11:40:27

2761960.txt

5 off the record for a second? 11:40:28

6 THE REPORTER: Please. 11:40:29

7 THE VIDEOGRAPHER: We are now 11:40:30

8 off the record. The time on the 11:40:31

9 video monitor is 11:39. 11:40:33

10 (Whereupon, a brief recess was 11:41:15

11 taken.) 11:41:15

12 THE VIDEOGRAPHER: We are on 11:41:15

13 the record. The time on the video 11:41:19

14 monitor is 11:40 a.m. 11:41:22

15 We are on the record. 11:41:35

16 MR. KEYHANI: Yes, thank you. 11:41:36

17 CONTINUED EXAMINATION BY MR. KEYHANI: 11:41:41

18 Q. Now, you said that you had met 11:41:41

19 with your lawyers in preparation of this 11:41:43

20 deposition? 11:41:46

21 A. Yes. 11:41:46

22 Q. About when did you meet with 11:41:48

23 them, today or yesterday? 11:41:50

24 A. Yesterday, this morning. 11:41:51

25 Q. Yesterday and this morning? 11:41:54

2761960.txt

2 A. Um hum. 11:41:55

3 Q. About how long? A few hours? 11:41:56

4 A. I couldn't tell you right off. 11:41:58

5 Several hours. 11:42:00

6 Q. Several hours. 11:42:01

7 And you mentioned you looked at 11:42:03

8 a couple of documents then we stopped. 11:42:05

9 Could you describe the documents you 11:42:07

10 reviewed in preparation for this 11:42:08

11 deposition? Do the best that you can. 11:42:10

12 A. Okay. 11:42:12

13 MR. BILLAH: Object as 11:42:13

14 attorney-client privilege. Instruct 11:42:14

15 the witness not to answer. 11:42:16

16 MR. KEYHANI: I'm only asking 11:42:18

17 for documents, not your 11:42:18

18 communications with your client -- 11:42:20

19 with your lawyer, just the documents 11:42:22

20 you reviewed, which you can testify 11:42:23

21 to. You can go ahead. 11:42:25

22 MR. BILLAH: Instruct the 11:42:27

23 witness not to answer. 11:42:28

24 I'll allow you to ask him 11:42:29

25 specific documents but asking about 11:42:31

1 LOWELL MALO

2 the collection of documents is 11:42:33

3 privileged, work product. 11:42:34

4 MR. KEYHANI: Actually, it's 11:42:35

5 not. I'm perfectly permitted to ask 11:42:37

6 the witness what documents he 11:42:40

7 reviewed in preparation for this 11:42:41

8 deposition. 11:42:43

9 I'm not asking him about 11:42:44

10 communications with counsel. 11:42:45

11 MR. BILLAH: You can ask him 11:42:46

12 what specific documents -- 11:42:48

13 MR. KEYHANI: I can ask him any 11:42:49

14 documents he reviewed. 11:42:52

15 Do you want to confer with your 11:42:52

16 co-counsel? I'm quite certain that 11:42:54

17 I'm allowed to ask him about any 11:42:56

18 documents. 11:42:58

19 MR. BILLAH: I'll allow it 11:42:58

20 because I don't think it's a big 11:43:00

21 deal, so go ahead. 11:43:02

22 MR. KEYHANI: Okay. 11:43:03

2761960.txt

23 CONTINUED EXAMINATION BY MR. KEYHANI: 11:43:03
 24 Q. I'm not getting into any of 11:43:03
 25 your communications with counsel, just the 11:43:06

25

1 LOWELL MALO
 2 documents that you reviewed. 11:43:08
 3 A. Um hum. 11:43:09
 4 Q. Go 'head. 11:43:11
 5 A. Okay. 11:43:12
 6 It was a combination of with 11:43:13
 7 the counsel and by myself. 11:43:14
 8 Q. Sure. 11:43:17
 9 A. By myself in a hotel room. 11:43:18
 10 Q. Of course. 11:43:21
 11 A. I looked at -- we read a 11:43:21
 12 couple -- the two declarations. 11:43:24
 13 Q. Yes? 11:43:25
 14 A. And scanned over some of the 11:43:26
 15 patents. 11:43:30
 16 Q. The prior art patents? 11:43:31
 17 A. Yes. 11:43:35
 18 Q. Anything else that you can 11:43:37
 19 recollect? 11:43:40

2761960.txt

20 A. No. 11:43:40

21 Q. Did you look at your own 11:43:41

22 declaration? 11:43:42

23 A. Yes. 11:43:42

24 Q. You submitted a couple of 11:43:44

25 declarations in connection with this 11:43:46

26

1 LOWELL MALO

2 matter? 11:43:48

3 A. Yes. 11:43:48

4 Q. Did you look at both of them? 11:43:48

5 A. Yes, I did. 11:43:50

6 Q. Okay. Anything else? 11:43:50

7 A. Not that I can think of right 11:43:55

8 now. 11:43:57

9 Q. Sure. 11:43:57

10 A. I did mention the patents 11:43:59

11 though? 11:44:01

12 Q. Yes, you did, you did. 11:44:01

13 A. Okay. 11:44:03

14 MR. KEYHANI: I would like to 11:44:09

15 have Patent Owner's Exhibit 1 marked 11:44:12

16 for the record. 11:44:19

2761960.txt

17 (Whereupon, the above-mentioned 11:44:20
18 Supplemental Expert Declaration of 11:44:20
19 Lowell Malo was marked Patent Owner's 11:44:20
20 Exhibit 1 for identification.) 11:44:28
21 MR. KEYHANI: Once we mark it 11:44:28
22 then you can take a look at it. 11:44:29
23 THE WITNESS: Okay. 11:44:30
24 MR. KEYHANI: Take a couple of 11:44:51
25 moments to look at it, please. 11:44:54

27

1 LOWELL MALO
2 THE WITNESS: It's long. It 11:44:57
3 will take me more than a few minutes. 11:44:58
4 MR. KEYHANI: That's fine. 11:45:01
5 I will direct you to specific 11:45:02
6 sections but just take a general 11:45:04
7 perusal. 11:45:10
8 THE WITNESS: Okay. 11:45:10
9 [Witness peruses Patent Owner's 11:45:10
10 Exhibit 1.] 11:45:10
11 CONTINUED EXAMINATION BY MR. KEYHANI: 11:46:15
12 Q. I have a general question for 11:46:15
13 you. 11:47:13

2761960.txt

14 A. Um hum. 11:47:14
15 Q. Do you recognize -- first of 11:47:14
16 all, do you recognize this declaration? 11:47:16
17 A. Yes. 11:47:18
18 Q. Okay. 11:47:18
19 At the front of it it's labeled 11:47:20
20 as a Supplemental Expert Declaration of 11:47:23
21 Lowell Malo? 11:47:27
22 A. Um hum. 11:47:29
23 Q. And I'd like to direct your 11:47:30
24 attention to page 11. 11:47:32
25 Is that your signature? 11:47:39

28

1 LOWELL MALO
2 A. Yes, it is. 11:47:40
3 Q. Okay. 11:47:41
4 Did you write this declaration 11:47:42
5 yourself? 11:47:43
6 A. Did I write it? 11:47:46
7 Q. Yes. 11:47:49
8 A. Generally, yes. 11:47:49
9 Q. What do you mean by 11:47:52
10 "generally"? 11:47:53

2761960.txt

11 A. I did not type it. 11:47:53

12 Q. Okay. 11:47:55

13 Were you provided a draft to 11:47:55

14 review by your lawyers? 11:48:02

15 A. The -- the attorneys prepared 11:48:05

16 the draft, they did the typing, sent it 11:48:07

17 to me for corrections or comments and we 11:48:10

18 went back and forth a couple of times 11:48:12

19 until I signed it, yes. 11:48:14

20 Q. The initial draft was provided 11:48:15

21 by your counsel? 11:48:18

22 A. Yes. 11:48:18

23 When you say "draft," you mean 11:48:20

24 the typed draft? 11:48:22

25 Q. Yes, nowadays most things are 11:48:23

29

1 LOWELL MALO

2 done I assume by typed? 11:48:26

3 A. Um hum. 11:48:28

4 Q. Did you have discussions with 11:48:29

5 your counsel -- I don't want to get into 11:48:34

6 those discussion details or anything 11:48:37

7 about them -- but did you have any 11:48:39

2761960.txt

8 discussions with counsel about the 11:48:42
9 subject matter of this case prior to 11:48:42
10 being provided with a draft declaration? 11:48:44
11 A. Yes. 11:48:47
12 Q. Okay. 11:48:49
13 And I'm not going to get into 11:48:50
14 the subject matter of those -- of those 11:48:51
15 conversations. Those are privileged. 11:48:54
16 In paragraph 10 on page 4 you 11:48:56
17 make a statement regarding the 1995 to 11:49:28
18 1997 timeframe. 11:49:34
19 A. Um hum. 11:49:35
20 Q. And you say that "a subway car 11:49:37
21 was normally constructed such that it had 11:49:41
22 had a cavity between its interior wall 11:49:43
23 and exterior shell." 11:49:48
24 A. Yes. 11:49:50
25 Q. Do you agree with that 11:49:50

30

1 LOWELL MALO
2 statement today? 11:49:51
3 A. Yes. 11:49:52
4 Q. You don't have any references 11:49:53

2761960.txt

5 for that. Do you have any references 11:49:55
6 that you have in mind or any support for 11:49:57
7 that proposition? 11:50:00
8 A. Well, it's mainly based on my 11:50:01
9 personal experience with the construction 11:50:05
10 of rail cars. 11:50:06
11 Q. Okay. 11:50:07
12 Besides your personal 11:50:07
13 experience, do you have anything else to 11:50:09
14 support that proposition here, the 11:50:11
15 proposition that I just read, "a subway 11:50:15
16 car was normally constructed such that it 11:50:18
17 had a cavity in between its interior wall 11:50:21
18 and exterior shell." 11:50:25
19 A. In terms of what substance? 11:50:26
20 What would you be looking for? 11:50:29
21 Q. Well, you looked at, as you 11:50:31
22 indicated today and in connection with 11:50:34
23 preparing in connection with these 11:50:35
24 declarations, a number of patents. 11:50:38
25 A. Um hum. 11:50:40

31

1

LOWELL MALO

Page 34

2761960.txt

2 Q. Do you believe any of those 11:50:41
3 patents that the petitioner that you are 11:50:43
4 working with has provided the -- did 11:50:47
5 those references provide or disclose 11:50:54
6 cavities within the wall as you describe 11:50:57
7 in paragraph 10? 11:51:00

8 MR. BILLAH: Objection. Lack 11:51:02
9 of foundation. 11:51:03

10 MR. KEYHANI: You can answer 11:51:07
11 the question unless he says you can't 11:51:08
12 answer the question. 11:51:11

13 A. Looking at the construction of 11:51:14
14 the patents, some of the illustrations 11:51:17
15 show or indicate that there would be 11:51:22
16 construction of that type, yes. 11:51:24

17 MR. KEYHANI: Well, let's take 11:51:31
18 a look at them for a moment. 11:51:33

19 THE WITNESS: Sure. 11:51:34

20 MR. KEYHANI: I'm going to 11:51:38
21 label this reference as PO No. 2. 11:51:39

22 (Whereupon, the above-mentioned 11:51:42
23 was marked Patent Owner's Exhibit 2 11:51:42
24 for identification.) 11:52:02

25 (Witness peruses Patent Owner's 11:52:02

2761960.txt

32

1 LOWELL MALO

2 Exhibit 2.) 11:52:06

3 MR. KEYHANI: We will call this 11:52:07

4 for short Namikawa, PO 2. 11:52:08

5 I understand it's a translation 11:52:13

6 of a patent in Japan. 11:52:14

7 THE WITNESS: Um hum. 11:52:17

8 CONTINUED EXAMINATION BY MR. KEYHANI: 11:52:17

9 Q. If you take a look at the 11:52:38

10 figures in this, Figure 1 for example, in 11:52:39

11 the -- in the patent? 11:52:43

12 A. Um hum. 11:52:45

13 Q. Where do you see an indication 11:52:49

14 that this figure discloses a cavity in 11:52:53

15 the wall between the interior wall and 11:53:00

16 the exterior wall? 11:53:07

17 A. Actually in this case it brings 11:53:08

18 the cavity interior to the interior wall 11:53:12

19 as well. 11:53:14

20 Q. I'm sorry, can you explain 11:53:15

21 that? 11:53:16

22 A. Sure. 11:53:16

2761960.txt

23 If you look at the construction 11:53:16
 24 here [indicating]? 11:53:18
 25 Q. Actually, you can make notes on 11:53:19

33

1 LOWELL MALO
 2 that draft that you have because that's 11:53:21
 3 the exhibit for the deposition. 11:53:23
 4 A. Okay. Well, I'm not going to 11:53:25
 5 make any notes. 11:53:26
 6 Q. Okay. 11:53:27
 7 A. But if you look at the wall 11:53:27
 8 here and the juncture that comes up, this 11:53:29
 9 is at a different angle. It's very, very 11:53:33
 10 common construction to come down from the 11:53:35
 11 roof and cut across at a diagonal, that 11:53:37
 12 allows you to turn the screens down to be 11:53:40
 13 able to be seen, and that forms a cavity 11:53:43
 14 back behind this area as well 11:53:46
 15 [indicating]. Great place for conduits, 11:53:47
 16 piping and such. 11:53:50
 17 Q. But you don't know that, you're 11:53:50
 18 speculating about that. 11:53:53
 19 Is there anywhere in this 11:53:55

2761960.txt

20 reference that -- that explains what you 11:53:57
 21 just said? 11:53:58
 22 A. Let me take the time to reread 11:53:59
 23 the whole thing. 11:54:02
 24 Q. Again, what we are trying to 11:54:05
 25 find out or I'm trying to learn from you 11:54:08

34

1 LOWELL MALO
 2 is if anywhere in this reference it 11:54:10
 3 states or describes a cavity in between 11:54:14
 4 the interior wall and the exterior shell. 11:54:17
 5 A. Okay. 11:54:23
 6 Just to be clear, you're 11:55:37
 7 looking at an example of wording in the 11:55:38
 8 text or -- 11:55:40
 9 Q. Any statement in this patent, 11:55:41
 10 anywhere in this patent, that indicates 11:55:45
 11 that there's a cavity between the 11:55:46
 12 interior wall and exterior wall. 11:55:48
 13 A. Okay. 11:55:50
 14 Q. Any statement, suggestion about 11:55:51
 15 it, discussion about it, anything. 11:55:54
 16 THE WITNESS: Okay. So may I 11:57:21

2761960.txt

17 ask a question? 11:57:22

18 MR. KEYHANI: No, 11:57:23

19 unfortunately, or fortunately, maybe 11:57:24

20 fortunate for me, you can't ask any 11:57:29

21 questions. 11:57:31

22 Q. Why don't we look at a second 11:57:32

23 exhibit. 11:57:34

24 A. Let's just stay with this one 11:57:34

25 for the time being. 11:57:37

35

1 LOWELL MALO

2 Q. Okay. Go ahead. 11:57:38

3 A. Okay. 11:57:38

4 So my statement is that we are 11:57:39

5 looking at an interior wall. 11:57:41

6 Q. My question that was pending 11:57:42

7 was -- 11:57:44

8 A. Yes. 11:57:45

9 MR. KEYHANI: If you can go 11:57:45

10 back and reread my question. 11:57:47

11 (The requested portion of the 11:57:47

12 record was read.) 11:58:33

13 MR. KEYHANI: That's the 11:58:33

2761960.txt

14 question pending. 11:58:33

15 A. Okay. 11:58:35

16 So there is an interior wall 11:58:35

17 and there's an exterior wall, so the 11:58:37

18 question is what's between them? That's 11:58:39

19 the question? 11:58:43

20 Q. I'm not asking for an 11:58:44

21 explanation from you. 11:58:45

22 A. Um hum. 11:58:46

23 Q. I'm asking if there is any 11:58:47

24 reference, any indication, writing in 11:58:49

25 this reference. 11:58:50

36

1 LOWELL MALO

2 A. I saw nothing in the wording. 11:58:50

3 Q. Okay. 11:58:52

4 A. The indication is strictly from 11:58:53

5 looking at the illustration. 11:58:54

6 Q. It's your interpretation of the 11:58:56

7 illustration? 11:58:58

8 A. Yes. 11:58:59

9 Q. Okay, thank you. 11:59:00

10 MR. KEYHANI: I'd like to mark 11:59:00

2761960.txt

11 Patent Owner Exhibit 3 I believe this 11:59:03
12 would be. 11:59:06
13 (Whereupon, the above-mentioned 11:59:07
14 Amano document was marked Patent Owner 11:59:07
15 Exhibit 3 for identification.) 11:59:21
16 MR. KEYHANI: Take a moment to 11:59:21
17 look at this exhibit. For short I'm 11:59:22
18 going to call this Amano, Patent 11:59:26
19 Owner's Exhibit 3. 11:59:30
20 I would like for you to take a 11:59:32
21 few moments or as many moments as you 11:59:35
22 need to look through the writing in 11:59:37
23 this patent -- it's not very long, 11:59:40
24 the writing, but it will still take 11:59:42
25 you a few minutes -- for any writing 11:59:45

37

1 LOWELL MALO
2 in this patent where it indicates, 11:59:47
3 suggests, describes that there is a 11:59:53
4 cavity between the interior wall and 11:59:58
5 its exterior shell of the rail car 12:00:02
6 that's being disclosed. 12:00:06
7 Take your time in looking at 12:00:09

2761960.txt

8 that and direct my attention to that 12:00:11
9 particular language, please. 12:00:13
10 (Witness peruses Patent Owner's 12:01:01
11 Exhibit 3.) 12:01:08
12 MR. KEYHANI: Let me know when 12:05:35
13 you're ready to answer the pending 12:05:36
14 question. 12:05:38
15 Could you read back the pending 12:05:38
16 question for us kindly. 12:05:41
17 (The requested portion of the 12:05:41
18 record was read.) 12:06:22
19 A. The reference to the cavity is 12:06:22
20 limited only to the pictures. There is 12:06:24
21 nothing in the writing. 12:06:26
22 Q. Your interpretation of the 12:06:28
23 figures? 12:06:29
24 A. Yes. 12:06:29
25 Q. But there is nothing in the 12:06:29

38

1 LOWELL MALO
2 writing that suggests or indicates that? 12:06:32
3 A. Not that I see. 12:06:35
4 MR. KEYHANI: I'd like to mark 12:06:36

2761960.txt

5 Exhibit PO 4. 12:06:39

6 (Whereupon, the above-mentioned 12:06:41

7 Miyajima document was marked Patent 12:06:41

8 Owner Exhibit 4 for identification.) 12:06:51

9 MR. KEYHANI: We will call this 12:06:51

10 one Miyajima for short. Take a look 12:06:56

11 at this, please. 12:07:03

12 I would like for you to do the 12:07:12

13 same thing as you did for the other 12:07:14

14 references. 12:07:17

15 THE WITNESS: Okay. 12:07:17

16 MR. KEYHANI: Look at the 12:07:18

17 writing here anywhere in the 12:07:18

18 disclosures and indicate if there is 12:07:21

19 any indication, description, 12:07:23

20 suggestion of a cavity in the wall 12:07:26

21 between the exterior and interior 12:07:36

22 wall, that is, any cavity between the 12:07:38

23 exterior and interior wall of the 12:07:40

24 rail car being described. 12:07:42

25 (Witness peruses Patent Owner's 12:08:22

2761960.txt

2 Exhibit 4.) 12:08:25

3 MR. KEYHANI: Let me know when 12:18:47

4 you're ready to answer the pending 12:18:48

5 question. 12:18:51

6 THE WITNESS: Okay. 12:18:52

7 CONTINUED EXAMINATION BY MR. KEYHANI: 12:19:00

8 Q. Can you answer the pending 12:19:00

9 question as to whether there are any 12:19:01

10 indications or descriptions or 12:19:03

11 suggestions of a cavity in the language 12:19:06

12 of the disclosure of this patent in front 12:19:09

13 of you? 12:19:12

14 MR. BILLAH: Objection, 12:19:12

15 compound. 12:19:13

16 MR. KEYHANI: I'll restate the 12:19:16

17 question. 12:19:17

18 Q. Is there any writing in this 12:19:18

19 patent before you -- excuse me, Patent 12:19:20

20 Owner No. 4, excuse me, indicating or 12:19:25

21 describing or suggesting a cavity in 12:19:29

22 between the exterior and interior wall of 12:19:35

23 the rail car? 12:19:38

24 A. There is no verbiage. 12:19:40

25 Q. Thank you. 12:19:43

1 LOWELL MALO

2 When you said there was no 12:20:07

3 verbiage, you mean there was no writing 12:20:08

4 in the patent specification that 12:20:11

5 describes or indicates or suggests a 12:20:13

6 cavity between the interior and exterior 12:20:14

7 wall; is that correct? 12:20:17

8 A. It talks about interior walls. 12:20:18

9 Q. Yes. 12:20:20

10 A. And that's about it. 12:20:20

11 Q. Okay. Thank you. 12:20:21

12 MR. KEYHANI: I'd like to mark 12:20:25

13 this next exhibit as Patent Owner 5. 12:20:27

14 I think this will be 5. 12:20:31

15 (Whereupon, the above-mentioned 12:20:33

16 Sasao document was marked Patent 12:20:33

17 Owner Exhibit 5 for identification.) 12:20:54

18 MR. KEYHANI: This is another 12:20:54

19 patent document, Patent Owner No. 5, 12:20:56

20 I think the author is Sasao, or one 12:21:03

21 of them is. We'll call it Sasao. 12:21:07

22 If you could take a few moments 12:21:10

2761960.txt

23 and go through the same exercise and 12:21:13
 24 see if there is any language in the 12:21:15
 25 disclosure of the patent that would 12:21:17

41

1 LOWELL MALO

2 indicate or suggest or describe a 12:21:19
 3 cavity between an interior and 12:21:24
 4 exterior of a rail car. Same 12:21:25
 5 question I've asked a couple of 12:21:28
 6 times. 12:21:30

7 THE WITNESS: Okay. 12:21:30

8 (Witness peruses Patent Owner's 12:22:13
 9 Exhibit 5.) 12:22:17

10 CONTINUED EXAMINATION BY MR. KEYHANI: 12:22:17

11 Q. What is your position or answer 12:26:26
 12 to the pending question on this 12:26:27
 13 reference? 12:26:30

14 THE WITNESS: Could you repeat 12:26:31
 15 the question, please? 12:26:32

16 MR. KEYHANI: Of course. 12:26:33

17 (The requested portion of the 12:26:33
 18 record was read.) 12:27:04

19 A. Specific to a rail car, no. 12:27:04

2761960.txt

20 Q. Thank you. 12:27:07

21 MR. KEYHANI: I'd like to mark 12:27:10

22 this next exhibit as No. 6, I think? 12:27:12

23 Thank you. 12:27:15

24 (Whereupon, the above-mentioned 12:27:16

25 Maekawa document was marked Patent 12:27:16

42

1 LOWELL MALO

2 Owner Exhibit 6 for identification.) 12:27:35

3 MR. KEYHANI: This is Patent 12:27:35

4 Owner's Exhibit 6, we will call this 12:27:37

5 by one of the inventor's names, 12:27:41

6 Maekawa. 12:27:44

7 If you could take a look at 12:27:44

8 this patent and answer the same 12:27:46

9 question, if there is any writing and 12:27:50

10 disclosure in this patent that would 12:27:52

11 indicate, suggest, describe the 12:27:55

12 existence of a cavity between the 12:27:58

13 exterior and interior wall of a rail 12:28:00

14 car, please. Thank you. 12:28:03

15 (Witness peruses Patent Owner's 12:36:12

16 Exhibit 6.) 12:36:16

2761960.txt

17 MR. KEYHANI: Let me know when 12:37:40
18 you're ready to proceed. 12:37:41
19 THE WITNESS: I just need to 12:37:43
20 look at something here. 12:37:44
21 MR. KEYHANI: Sure. 12:37:45
22 THE WITNESS: Okay. 12:38:00
23 MR. KEYHANI: Could you please 12:38:02
24 read the pending question, please. 12:38:03
25 (The requested portion of the 12:38:03

43

1 LOWELL MALO
2 record was read.) 12:38:03
3 MR. KEYHANI: I'm sorry, it's 12:38:28
4 Maekawa, I apologize. 12:38:29
5 A. The answer is yes. 12:38:54
6 CONTINUED EXAMINATION BY MR. KEYHANI: 12:38:56
7 Q. Could you direct your attention 12:38:56
8 to that, please. 12:38:58
9 A. Sure. 12:39:00
10 Over here on the second page in 12:39:00
11 the last paragraph [indicating]. 12:39:01
12 Q. Yup? 12:39:03
13 A. It refers to things being 12:39:03

2761960.txt

14 installed. 12:39:06

15 Q. Can you read the section, 12:39:06

16 please. 12:39:07

17 A. Okay. How far back can we go? 12:39:10

18 It's the second to the last paragraph. 12:39:13

19 Q. Okay. Go ahead and read it. 12:39:14

20 A. In Figure 1 and Figure 2, (1) 12:39:16

21 indicates a car body for an electric 12:39:18

22 train; doors (entrances and exits) (11), 12:39:20

23 (12), (13)... (16) and (17), (18), (19) 12:39:20

24 ... (22) are provided in six locations on 12:39:23

25 each side, in the sides of this car body 12:39:25

44

1 LOWELL MALO

2 (1); and television receivers (101), 12:39:29

3 (102), (103)... (124) are installed above 12:39:32

4 the left and right door pocket parts for 12:39:33

5 each of the doors." Okay? 12:39:37

6 And it refers to door pocket 12:39:38

7 parts a little bit farther down. The 12:39:40

8 door pocket is a void between the inner 12:39:44

9 and outer wall that allows a door to pass 12:39:46

10 into it, that's a pocket door. 12:39:50

2761960.txt

11 Q. And that to you indicates that 12:39:54
12 there is a cavity between -- between the 12:39:56
13 exterior and interior wall of the car? 12:40:01
14 A. The door goes into the cavity, 12:40:02
15 yes. 12:40:06
16 Q. Okay. 12:40:06
17 What about -- what about the 12:40:06
18 cavity at the junction of the side wall 12:40:08
19 and the ceiling; is that disclosed in 12:40:11
20 this reference? 12:40:13
21 A. Specifically here, no. 12:40:13
22 Q. You've read the entire Maekawa 12:40:16
23 reference and you've read all the other 12:40:20
24 references that we went over. 12:40:23
25 Was there a discussion, 12:40:25

45

1 LOWELL MALO
2 description, suggestion or indication in 12:40:26
3 any of the references that you just 12:40:28
4 reviewed this morning of a cavity between 12:40:30
5 the exterior wall and the interior wall 12:40:38
6 at the junction of the rail car, at the 12:40:40
7 junction between the ceiling and side 12:40:50

Page 50

2761960.txt

8 wall? 12:40:51

9 A. Right, okay. Not directly. 12:40:52

10 Indirectly, yes. 12:40:54

11 Q. Did you not just testify 12:40:56

12 earlier that none of the other references 12:40:58

13 had any disclosure of a cavity between 12:41:00

14 the exterior and the interior wall, 12:41:04

15 period? 12:41:06

16 MR. BILLAH: Objection to 12:41:07

17 mischaracterization of prior 12:41:08

18 testimony. 12:41:09

19 Q. With the exception of Maekawa, 12:41:10

20 you testified earlier that none of the 12:41:13

21 other references you reviewed had any 12:41:15

22 indication, suggestion or teaching of a 12:41:18

23 cavity between the exterior wall and the 12:41:21

24 interior wall; correct? 12:41:23

25 MR. BILLAH: Same objection. 12:41:24

46

1 LOWELL MALO

2 MR. KEYHANI: You can testify. 12:41:28

3 A. No verbal indication, yes. 12:41:30

4 Q. Okay, no verbal indication. 12:41:32

2761960.txt

5 And in Maekawa there was no 12:41:34
6 verbal indication, you testified, now to 12:41:38
7 be clear, there is no verbal indication 12:41:40
8 of a cavity between the interior/exterior 12:41:42
9 wall at the junction of the side wall and 12:41:47
10 the ceiling; is that correct? 12:41:49
11 A. What it says is that there is a 12:41:52
12 door pocket. 12:41:54
13 Q. A door pocket? 12:41:55
14 A. Which is a cavity in the wall. 12:41:56
15 Q. At the -- at the door level? 12:41:59
16 A. At the door level. 12:42:00
17 Q. But at no other location? 12:42:01
18 A. There is no reason not to have 12:42:03
19 a cavity. The doors -- the walls are 12:42:05
20 relatively straight. Unless the walls, 12:42:09
21 there's an indication to change it, no. 12:42:12
22 Q. Again my question was is there 12:42:14
23 any verbiage, indication or description 12:42:15
24 of a cavity in the wall between the 12:42:18
25 interior and exterior wall at the 12:42:20

47

1

LOWELL MALO

Page 52

2761960.txt

2 junction of the ceiling and the side 12:42:22
3 wall, that's the question, in Maekawa, in 12:42:24
4 the verbiage, in the language of this 12:42:29
5 patent? 12:42:32
6 A. In the verbiage -- let me see 12:42:33
7 here -- it says television receivers are 12:42:37
8 installed above the left and right door 12:42:49
9 pockets. 12:42:51
10 Q. And we're talking about the 12:42:55
11 junction of the ceiling and the side 12:42:56
12 wall? 12:42:58
13 A. Yes. 12:42:59
14 Q. And your answer is? 12:43:41
15 A. There is no verbiage that the 12:43:44
16 door pocket, that that cavity extends 12:43:47
17 beyond it. 12:43:50
18 Q. Beyond the -- beyond the door 12:43:50
19 pocket? 12:43:52
20 A. Yes. 12:43:52
21 Q. I have another question for 12:43:53
22 you. Can you take a look at Namikawa, 12:43:55
23 please, for a second. 12:43:58
24 MR. BILLAH: Counsel, we would 12:44:13
25 like to break for lunch soon. 12:44:14

1 LOWELL MALO

2 MR. KEYHANI: Yes, after we're 12:44:16

3 done with this line -- shortly after 12:44:17

4 we're done with this line of 12:44:18

5 questioning then we can take a break. 12:44:20

6 MR. BILLAH: That's fine. 12:44:21

7 Q. You had an opportunity to read 12:44:32

8 Namikawa, which is labeled as Patent 12:44:34

9 Owner's No. 2, Exhibit No. 2? 12:44:40

10 A. Um hum. 12:44:45

11 Q. Can you tell me whether in this 12:44:46

12 disclosure in this patent there is any 12:44:48

13 indication as to any mounting structure 12:44:50

14 in the -- of the -- for the TV monitors 12:45:01

15 in the rail car, any structure that would 12:45:03

16 mount TV panels or the monitors in the 12:45:07

17 rail car. 12:45:11

18 (Witness peruses exhibit.) 12:46:00

19 A. I don't see a reference to a 12:46:05

20 mounting structure. 12:46:14

21 Q. I want to direct your attention 12:46:21

22 to, in Namikawa, to page 4. If you look 12:46:23

2761960.txt

23 at the section that says Means For 12:46:36
24 Solving -- For Solving the Problems? 12:46:38
25 A. Um hum. 12:46:41

49

1 LOWELL MALO

2 Q. If you could read the first two 12:46:42
3 sentences, please, on the record. You 12:46:51
4 can read them aloud, please. 12:46:54
5 A. "In order to achieve the object 12:46:56
6 described above, the present device 12:46:58
7 allows broadcasting of commercials or 12:47:00
8 broadcast programming taken from 12:47:02
9 broadcasting media by disposing a 12:47:05
10 plurality of televisions on a wall face 12:47:08
11 inside a car of a transit bus, electric 12:47:16
12 train or the like." 12:47:17
13 Q. That's fine. 12:47:19
14 Reading this first sentence -- 12:47:28
15 and you can go on and read to yourself 12:47:30
16 the rest of it if you wish for context -- 12:47:31
17 is this patent in your view speaking to 12:47:34
18 or talking about a television screen on a 12:47:39
19 wall or in a wall? 12:47:44

Page 55

2761960.txt

20 A. The wording is on a wall face. 12:48:02
21 Q. And how do you understand or 12:48:05
22 what do you understand that to mean? 12:48:09
23 Does that mean on top of the wall or 12:48:11
24 inside the wall, "on a wall face"? 12:48:13
25 A. Depends on the mounting. If 12:48:15

50

1 LOWELL MALO
2 you had, for example, a flat metal with 12:48:18
3 screws on it it would push back into it, 12:48:22
4 that's considered face mounting, it's 12:48:25
5 mounted to the face of the wall even 12:48:29
6 though it does project back into the 12:48:32
7 wall. 12:48:34
8 Q. You testified a few moments ago 12:48:35
9 that there is no indication about 12:48:37
10 mounting structure in this particular 12:48:38
11 patent. 12:48:40
12 A. Right. 12:48:40
13 Q. Okay. 12:48:41
14 Given that being the case and 12:48:41
15 it describes the patent discloses 12:48:45
16 televisions, a plurality -- disposing a 12:48:48

2761960.txt

17 plurality of televisions on a wall 12:48:53
 18 face -- 12:48:55
 19 A. Um hum. 12:48:55
 20 Q. -- do you read that as placing 12:48:56
 21 televisions on the wall or inside the 12:48:57
 22 wall? 12:48:59
 23 A. Again, I think it depends on 12:49:07
 24 the mounting. 12:49:23
 25 Q. Okay. In this context. 12:49:24

51

1 LOWELL MALO
 2 A. Um hum. 12:49:26
 3 Q. Let me show you another section 12:49:27
 4 here. 12:49:29
 5 A. Sure. 12:49:30
 6 Q. On page 2, lines 4 through 6. 12:49:30
 7 A. Page 2. 12:49:34
 8 Q. Of the same patent. 12:49:35
 9 A. Okay. 12:49:37
 10 Q. Line 4 says -- let's see here 12:49:42
 11 -- well, under what's numbered as 2, I 12:49:49
 12 guess the line that's more difficult in 12:49:51
 13 that sentence that's numbers 2 (1), it 12:49:54

2761960.txt

14 says: "The public transport vehicle 12:49:56
 15 characterized in that commercials or 12:50:00
 16 broadcast programming taken from 12:50:02
 17 broadcasting media can be broadcast by 12:50:04
 18 disposing a plurality of televisions on a 12:50:08
 19 wall face inside a car of a transit bus, 12:50:11
 20 electric train or the like." 12:50:15
 21 Is this, do you understand this 12:50:19
 22 to be on the wall or inside the wall, 12:50:21
 23 these TV's? 12:50:23
 24 You could also take a look at 12:50:26
 25 page 6 of the same disclosure, at lines 2 12:50:28

52

1 LOWELL MALO
 2 and 3: "Crystal televisions 12 are 12:50:35
 3 disposed along the direction of travel on 12:50:45
 4 a wall face above each seat 11." 12:50:49
 5 Or page 8, lines 3 and 4 of 12:50:58
 6 page 8: "A liquid crystal televisions 22 12:51:01
 7 are disposed on a wall face above the 12:51:10
 8 window side of seat 21 in a car 20 of a 12:51:14
 9 transit bus," and there are a few other 12:51:21
 10 references. 12:51:24

Page 58

2761960.txt

11 It repeatedly says "on a wall 12:51:25
12 face." 12:51:28
13 A. Um hum. 12:51:28
14 Q. Do you understand it to mean 12:51:29
15 putting a TV on the wall of the interior 12:51:30
16 or do you understand the language to mean 12:51:33
17 putting the TV inside the wall in this 12:51:36
18 particular context? 12:51:38
19 A. Within terminology common 12:51:44
20 within the rail industry, when you say 12:51:48
21 something is wall-mounted, can it be 12:51:50
22 mounted outside, yes. We would not do 12:51:54
23 that. If there is a flange that goes 12:51:56
24 around and they run the outside screws 12:51:59
25 into it we still call it wall-mounted. 12:52:01

53

1 LOWELL MALO
2 I'm not clear of their definition of wall 12:52:05
3 mounted. 12:52:07
4 Q. I understand, but you did have 12:52:08
5 a chance to read this, this patent a few 12:52:09
6 minutes ago. 12:52:11
7 A. Yes, um hum. 12:52:11

2761960.txt

8 Q. So it's not a trick question 12:52:12
9 taking it out of the context. I gave you 12:52:16
10 time to read it, it's not very long, it's 12:52:18
11 actually one of the shorter 12:52:21
12 specifications, fairly. 12:52:24
13 How do you read this patent 12:52:25
14 when it talks about putting the 12:52:26
15 television screens on -- on the wall? Do 12:52:29
16 you read it as putting it on the surface 12:52:34
17 of the wall or inside the wall? What is 12:52:35
18 your reading of it? Again, this is from 12:52:37
19 your perspective. 12:52:40
20 A. Yeah. Again, from my 12:52:41
21 perspective it can be partially inside 12:52:43
22 the wall. It depends on the wall 12:52:45
23 mounting. 12:52:47
24 Q. In this context? 12:52:47
25 A. Yes. 12:52:49

54

1 LOWELL MALO
2 Now somebody else reading it 12:52:51
3 might interpret it like hanging a picture 12:52:53
4 on a wall. 12:52:56

2761960.txt

5 Q. How do you interpret it in this 12:52:56
6 context? 12:52:58

7 A. I've got it either face- 12:52:58
8 mounted, either all the way outside or 12:53:00
9 face-mounted where part of it is tucked 12:53:03
10 into the wall. 12:53:05

11 Q. Having read this patent now, 12:53:06
12 not just a few lines out of context, do 12:53:08
13 you -- how do you -- what does Namikawa 12:53:10
14 -- Namikawa teach, disclose to you, does 12:53:15
15 it disclose, specifically in this 12:53:19
16 particular patent, does this reference to 12:53:23
17 you or in this reference are they 12:53:26
18 teaching or are they disclosing a TV put 12:53:29
19 on the wall or a TV that's a screen 12:53:35
20 monitor that's inside the wall? 12:53:39

21 MR. BILLAH: Objection. Asked 12:53:41
22 and answered. 12:53:43

23 MR. KEYHANI: You can answer 12:53:43
24 the question. 12:53:43

25 A. Again, definitions within 12:53:47

2761960.txt

2 people who do this, it can be partially 12:53:51

3 inside the wall and still be on the wall. 12:53:53

4 Q. I understand. 12:53:56

5 A. It depends on the mounting. 12:53:57

6 Q. Okay. 12:53:59

7 But from this disclosure, we 12:54:00

8 don't have any more than what's disclosed 12:54:02

9 in this patent. 12:54:04

10 A. Um hum. 12:54:05

11 Q. So what's being disclosed in 12:54:05

12 this patent, what do you understand it to 12:54:07

13 mean? You say it could mean either one, 12:54:10

14 and I understand I heard your answer, I'm 12:54:13

15 not trying to change or argue with that 12:54:15

16 answer. 12:54:17

17 In this particular context what 12:54:17

18 are they talking about, which one of 12:54:19

19 those categories? Is it inside the wall 12:54:20

20 partially or is it on the outside of the 12:54:24

21 wall, as you read this disclosure? 12:54:25

22 MR. BILLAH: Objection. Asked 12:54:28

23 and answered. 12:54:30

24 Q. You can't tell me? 12:54:30

25 A. If it's face-mounted, again, 12:54:32

2761960.txt

56

1 LOWELL MALO

2 it's how is it mounted. If it's face- 12:54:35

3 mounted or wall-mounted, again, there 12:54:38

4 could be a hole cut in there, you put a 12:54:40

5 screw in there and put it on, that's 12:54:43

6 considered face-mounted or wall-mounted. 12:54:46

7 Q. So this disclosure doesn't 12:54:48

8 clarify one way or the other, you're 12:54:50

9 saying, to you, could be either way? 12:54:52

10 A. It would not be -- well, I 12:54:53

11 can't say that either. 12:54:58

12 Again, it's a face-mounted, can 12:55:01

13 it be either, can you hang it on the 12:55:05

14 outside? It would not be a normal way to 12:55:08

15 do it. 12:55:11

16 Q. I guess I'm asking you what do 12:55:11

17 you glean from this reference. Does it 12:55:13

18 tell you whether it's partially inside or 12:55:16

19 is it on the outside, which one of those 12:55:18

20 categories do you read this to be 12:55:21

21 disclosing as the invention? 12:55:23

22 Presumably the invention is to 12:55:24

2761960.txt

23 teach somebody of ordinary skill in the 12:55:27
 24 art to do this. 12:55:29
 25 A. Um hum. 12:55:31

57

1 LOWELL MALO

2 Q. That's the purpose in part, I 12:55:31
 3 guess? 12:55:33

4 A. Um hum. 12:55:33

5 Q. So you're of at least ordinary 12:55:33
 6 skill in the art. 12:55:36

7 A. Um hum. 12:55:37

8 Q. Respectfully, how do you read 12:55:37
 9 the disclosure here? 12:55:41

10 Do you understand this to be 12:55:41
 11 they're disclosing or teaching a monitor 12:55:44
 12 to be partially inserted in the wall or a 12:55:46
 13 monitor being placed on the wall in this 12:55:49
 14 context? 12:55:51

15 MR. BILLAH: Objection. Asked 12:55:52
 16 and answered. 12:55:53

17 MR. KEYHANI: I didn't ask and 12:55:53
 18 answer it. I'm trying to elaborate, 12:55:55
 19 get an elaboration of an answer that 12:55:58

2761960.txt

20 was provided. 12:56:00
 21 You can answer the question. 12:56:01
 22 THE WITNESS: Okay. 12:56:02
 23 A. The patent to me had to do with 12:56:04
 24 the location and the placement of a TV 12:56:09
 25 screen. 12:56:12

58

1 LOWELL MALO
 2 Q. Okay. 12:56:12
 3 A. My interpretation, when you say 12:56:14
 4 mounted on the wall or face mounting is a 12:56:17
 5 flash mounting generally on the front. 12:56:22
 6 Q. It doesn't talk about face 12:56:24
 7 mounting, it only talks about on the wall 12:56:26
 8 mounting; would you agree with that? 12:56:28
 9 A. Same thing. 12:56:30
 10 Q. Okay. 12:56:31
 11 So, go ahead, what is your 12:56:31
 12 understanding in this disclosure. Is it 12:56:32
 13 talking about a monitor partially inside 12:56:34
 14 the wall? Is Namikawa talking about a TV 12:56:37
 15 monitor partially inside the wall or a 12:56:41
 16 monitor on the wall? Which one of those 12:56:44

Page 65

2761960.txt

17 do you interpret the patent discloses? 12:56:46
 18 MR. BILLAH: Objection. Asked 12:56:48
 19 and answered. 12:56:49
 20 MR. KEYHANI: You can answer 12:56:50
 21 the question. 12:56:51
 22 THE WITNESS: Okay. 12:56:51
 23 A. I don't know what's in that 12:56:53
 24 gentleman's head, what his intention was. 12:56:55
 25 I can only tell you how I would interpret 12:56:57

59

1 LOWELL MALO
 2 it. 12:57:00
 3 Q. And how would you interpret 12:57:00
 4 what he's trying to ask people to do with 12:57:01
 5 this disclosure? 12:57:03
 6 A. I said mounted on a wall, and 12:57:04
 7 that could be one of several ways, you 12:57:07
 8 can stick it on the outside of the wall, 12:57:09
 9 you could face mount. We would face 12:57:11
 10 mount it to make it flush. 12:57:15
 11 Q. Your reading of this is it 12:57:16
 12 could be done in several ways? 12:57:19
 13 A. Depending on the interpreter, 12:57:20

2761960.txt

14 yes. 12:57:23
15 Q. And people with ordinary skill 12:57:23
16 in the art could have their different 12:57:25
17 interpretations of the same reference? 12:57:27
18 A. Not too much but... 12:57:29
19 Q. But with respect to this issue. 12:57:30
20 A. But it would be very close. 12:57:32
21 Q. I guess I'm just trying to nail 12:57:35
22 down, what would you take from this. If 12:57:38
23 you read this, as one of ordinary skill 12:57:40
24 in the art, do you take that the inventor 12:57:43
25 of this patent, inventors, were trying to 12:57:47

60

1 LOWELL MALO
2 teach a television screen being mounted 12:57:49
3 partially -- because you gave two 12:57:53
4 possibilities -- partially mounted inside 12:57:55
5 the wall or hung on the wall, as you put 12:57:57
6 it, on the wall? 12:57:59
7 What do you read this 12:58:00
8 disclosure as, on the wall like hung on 12:58:02
9 the wall, or partially inside the wall? 12:58:05
10 MR. BILLAH: Objection. Asked 12:58:08

Page 67

2761960.txt

11 and answered. 12:58:10

12 MR. KEYHANI: I'm trying to get 12:58:10

13 a clarification. I apologize for 12:58:12

14 asking the question in different 12:58:14

15 ways. 12:58:16

16 THE WITNESS: That's okay. 12:58:16

17 You're doing your job. I'm doing 12:58:18

18 mine. 12:58:20

19 A. Okay. I mean for me the patent 12:58:21

20 had about the placement of the TV 12:58:24

21 screens. 12:58:27

22 Q. Yes. 12:58:27

23 A. Okay? The term on the wall or 12:58:27

24 in the wall or the definition to me 12:58:30

25 wasn't that important when I read the 12:58:33

61

1 LOWELL MALO

2 patent initially. It was the location of 12:58:35

3 the screens up at the junction, multi- 12:58:38

4 positions down. It does the same job 12:58:43

5 regardless of how it's mounted. That was 12:58:46

6 my initial impression. 12:58:48

7 Q. So are you saying that it's not 12:58:50

2761960.txt

8 clear to you whether it's inside the wall 12:58:51
9 or on the outside of the wall, on that 12:58:53
10 issue? 12:58:56
11 A. Yeah. 12:58:57
12 Q. What's being disclosed here, 12:58:59
13 basically? 12:59:01
14 A. Again, the way I would 12:59:02
15 interpret it, it's wall-mounted or 12:59:04
16 face-mounted. 12:59:07
17 Q. Okay. 12:59:07
18 A. And when you're mounting on the 12:59:07
19 outside, part of it may protrude inside. 12:59:09
20 Now, the gentleman may have a 12:59:22
21 different definition, but I didn't see a 12:59:24
22 definition either way. 12:59:26
23 Q. Could one of ordinary skill in 12:59:33
24 the art also interpret the monitors to be 12:59:35
25 placed on the wall -- as you put, I need 12:59:37

62

1 LOWELL MALO
2 to clarify your own language -- to be 12:59:39
3 hanging on the wall in this context? 12:59:43
4 A. It would be bad skill. Could 12:59:46

2761960.txt

5 you do it? Yes. But why? 12:59:48

6 Q. Would one of ordinary skill in 12:59:50

7 the art interpret this reference to be 12:59:51

8 teaching a television screen being placed 12:59:54

9 on the wall as opposed to inside the 12:59:58

10 wall, or is that -- would that be 13:00:02

11 unreasonable? 13:00:03

12 A. It would not be reasonable for 13:00:05

13 somebody who is knowledgeable in the best 13:00:09

14 practices to just hang it on the outside 13:00:12

15 someplace. 13:00:16

16 Q. But it would -- but would it 13:00:19

17 have to be in the wall? 13:00:22

18 A. Would it have to be in the 13:00:23

19 wall? We have other patents that showed 13:00:26

20 the whole screen could be totally outside 13:00:31

21 of a wall to the point the screens are so 13:00:35

22 thin it looks flat. 13:00:38

23 The other thing to notice in 13:00:55

24 this patent is that they have built 13:00:56

25 another interior wall. So could it go 13:00:59

63

1

LOWELL MALO

Page 70

2761960.txt

2 back into the wall, yes, because they 13:01:09

3 have generated the space to do so. 13:01:11

4 MR. KEYHANI: Do you want to 13:01:50

5 take a break? 13:01:51

6 THE WITNESS: Thank you. 13:01:53

7 MR. KEYHANI: Do you want to 13:01:53

8 take that break? 13:01:55

9 MR. BILLAH: Sure. 13:01:55

10 THE VIDEOGRAPHER: Okay. We 13:01:56

11 are now off the record. The time on 13:01:57

12 the video monitor is 1:01 p.m. 13:01:59

13 [Whereupon, after a luncheon 13:58:00

14 recess was taken, the following was 13:58:00

15 had:] 13:58:00

16 13:58:00

17 A F T E R N O O N S E S S I O N 13:58:00

18 14:11:36

19 THE VIDEOGRAPHER: We are now 14:11:36

20 on the record. The time on the video 14:12:11

21 monitor is 2:11 p.m. 14:12:13

22 CONTINUED EXAMINATION BY MR. KEYHANI: 14:12:17

23 Q. Could you please take a look at 14:12:17

24 Patent Owner's Exhibit 1, please. 14:12:20

25 A. Okay. 14:12:23

1 LOWELL MALO

2 Q. I direct your attention to page 14:12:25

3 8, this is part of paragraph 15. 14:12:34

4 A. Okay. 14:12:38

5 Q. You reference NYCT R-38 14:12:40

6 railcars built. Is there some document 14:12:53

7 that you're referencing or are you just 14:12:55

8 talking about them generally? 14:12:56

9 A. I'm talking about my personal 14:12:58

10 experience with the cars. 14:13:00

11 Q. Okay. 14:13:01

12 So there is no reference with a 14:13:01

13 document? 14:13:04

14 A. No. 14:13:04

15 Q. Any reason why there was no 14:13:04

16 literature or materials about that 14:13:06

17 particular car not disclosed in your 14:13:08

18 declaration? 14:13:14

19 A. Not particularly. 14:13:15

20 Q. Okay. 14:13:19

21 A. It's something that I've 14:13:20

22 personally seen and personally could 14:13:22

2761960.txt

23 attest to. These other cars they have 14:13:23
 24 that I have not seen so I can't say 14:13:26
 25 anything personally about them. 14:13:29

65

1 LOWELL MALO

2 Q. I see. 14:13:30

3 MR. KEYHANI: Mark this 14:13:51

4 document, will this be PO 7? 14:13:53

5 THE REPORTER: Yes. 14:13:53

6 (Whereupon, the above-mentioned 14:15:02

7 proposed FRA regulations document was 14:15:02

8 marked Patent Owner's Exhibit 7 for 14:15:02

9 identification.) 14:15:02

10 CONTINUED EXAMINATION BY MR. KEYHANI: 14:14:17

11 Q. I'm not going to make you read 14:14:17

12 this entire document. 14:14:19

13 A. That's good. 14:14:20

14 Q. In your declaration, page 9 14:14:23

15 onto 10, you reference this document, 14:14:34

16 this proposed FRA document. 14:14:38

17 Can you take a look at this 14:14:57

18 document and tell me what this is, 14:14:58

19 proposed FRA regulations document. 14:15:02

2761960.txt

20 A. All right. 14:15:06
 21 Q. I'm pointing to paragraph 18 14:15:07
 22 where you reference this document; what 14:15:09
 23 is this document? 14:15:11
 24 A. This document is the -- is 14:15:13
 25 this the proposed or is this final -- 14:15:18

66

1 LOWELL MALO
 2 this is the notice of proposed 14:15:21
 3 rulemaking, so this is a document that 14:15:23
 4 publishes the laws, if you will, as 14:15:27
 5 changed by the Federal Railway 14:15:30
 6 Administration, they are changed 14:15:34
 7 literally by Congress, I'm guessing. 14:15:36
 8 Q. Who writes this document? 14:15:39
 9 A. It's finalized by somebody at 14:15:40
 10 the Federal Railway Administration, but 14:15:44
 11 it gets sent to a committee of people to 14:15:45
 12 get a consensus, who write it together, 14:15:48
 13 and then the FRA picks it up from there. 14:15:51
 14 Q. Are there people with skill or 14:15:54
 15 technical skill in the art in the railway 14:15:57
 16 design area that are involved in the 14:16:00

2761960.txt

17 proposed regulations? 14:16:02

18 A. Generally, yes. 14:16:04

19 Q. People like yourself? 14:16:05

20 A. Not on this particular document, 14:16:07

21 but I've been part of other documents, 14:16:08

22 yes. 14:16:10

23 Q. And these are proposed, means 14:16:11

24 that at the time they weren't yet -- they 14:16:13

25 weren't yet actual regulations but they 14:16:15

67

1 LOWELL MALO

2 were proposals to the regulations? 14:16:18

3 A. Yes, um hum. 14:16:21

4 Q. Do you know if any of these 14:16:22

5 proposals became ultimately regulations? 14:16:24

6 A. Yes, they did. 14:16:27

7 Q. Any particular ones? Most of 14:16:28

8 it? Part of it? 14:16:30

9 A. Most of it. 14:16:30

10 Q. Do you generally find these 14:16:53

11 regulations to be consistent with your 14:17:00

12 experience in terms of the various 14:17:03

13 regulatory issues that they addressed? 14:17:07

2761960.txt

14 Is it consistent, the way they 14:17:10
15 addressed it, is it consistent with the 14:17:12
16 way you would address it from your own 14:17:15
17 expertise? 14:17:17
18 A. Actually, these regulations are 14:17:17
19 guides -- not guides, but they tell me 14:17:22
20 how to address a situation; so it's 14:17:24
21 federal law and that's what we do. 14:17:28
22 Q. Okay, understood. 14:17:30
23 My question is as somebody that 14:17:32
24 has years of experience in your art -- 14:17:34
25 A. Um hum. 14:17:37

68

1 LOWELL MALO
2 Q. -- in design or managing the 14:17:37
3 design of rail cars and various systems 14:17:42
4 like that -- 14:17:47
5 A. Um hum. 14:17:48
6 Q. -- do you find these 14:17:49
7 regulations to be reasonable? I mean, 14:17:50
8 informative? Thoughtful? 14:17:54
9 A. After you go through several 14:17:59
10 iterations, yes, because they'll come 14:18:01

2761960.txt

11 through with some things that sometimes 14:18:04
12 they're not so reasonable, you have the 14:18:07
13 right to read them, you have the right to 14:18:08
14 object, you have the right to have them be 14:18:12
15 modified. 14:18:15

16 Q. When you say who, who has a 14:18:16
17 right to object to it? 14:18:18

18 A. Everybody. 14:18:19

19 Q. I'm not trying to be cute. I 14:18:21
20 don't know the industry as well as you 14:18:24
21 do, obviously. 14:18:25

22 A. Okay. 14:18:25

23 Q. Who is "everybody"? Like, for 14:18:26
24 example, who are the constituents, let's 14:18:28
25 say, that would have a right to object to 14:18:31

69

1 LOWELL MALO

2 it? 14:18:33

3 A. Okay. 14:18:33

4 You would have the rail car 14:18:33
5 manufacturers, the major rail car 14:18:35
6 consulting companies, the rail car 14:18:39
7 suppliers would be involved in it. 14:18:42

2761960.txt

8 Q. A company that you worked for, 14:18:43
9 for example, could provide input? 14:18:45
10 A. Yes. 14:18:47
11 Q. In what capacity would you put 14:18:47
12 yourself, your company in, in the 14:18:49
13 manufacturing area? Design? 14:18:51
14 A. Uh, design. 14:18:53
15 Q. Design? 14:18:55
16 A. Um hum. 14:18:55
17 Q. Rail car design? 14:18:56
18 A. Yes. 14:18:58
19 Q. You referenced this particular 14:19:02
20 document that's why I brought it in to 14:19:04
21 this deposition. 14:19:08
22 A. Sure. 14:19:09
23 Q. Have you looked through this 14:19:09
24 proposed FRA document? 14:19:11
25 A. I've looked through it in a 14:19:12

70

1 LOWELL MALO
2 different format, they actually publish a 14:19:15
3 book. 14:19:17
4 Q. Right. 14:19:17

2761960.txt

5 A. On the final requirements. 14:19:18

6 Q. So you've gone through it 14:19:20

7 generally? 14:19:22

8 A. Yes. 14:19:22

9 Q. Do you find this, the proposed 14:19:22

10 regulations in this particular form, 14:19:26

11 generally reasonable in terms of 14:19:29

12 consistent with your expertise? 14:19:34

13 A. Yes. 14:19:36

14 Q. So you don't think it needs too 14:19:36

15 much editing? 14:19:39

16 A. The editing has already been 14:19:41

17 done. 14:19:43

18 Q. This is a later version of 14:19:43

19 this, this is further down the track in 14:19:45

20 other words? 14:19:47

21 A. Yeah, the proposed rulemaking 14:19:48

22 will be issued after it's gone through 14:19:50

23 several internal iterations and then 14:19:52

24 it's decided to proceed with it, go out to 14:19:54

25 the public. 14:19:57

71

2761960.txt

2 Q. Right. 14:19:58

3 A. And go through that. 14:19:59

4 Q. Do these regulations focus on 14:20:12

5 particular topics that are of particular 14:20:15

6 importance to the department of 14:20:20

7 transportation in connection with rail 14:20:22

8 cars and transportation cars? 14:20:25

9 A. These particular regulations 14:20:27

10 have to do with the passenger equipment 14:20:29

11 safety standards, so it's aimed at 14:20:31

12 safety. 14:20:33

13 Q. Passenger equipment? 14:20:33

14 A. Yes. 14:20:35

15 Q. What -- what would you consider 14:20:36

16 to be passenger equipment, for example? 14:20:37

17 How would you define that in your 14:20:40

18 perspective, when they're talking about 14:20:42

19 it? Obviously everybody may have a 14:20:44

20 different view but... 14:20:46

21 A. These particular standards 14:20:48

22 refer to -- refer directly to any 14:20:50

23 passenger car that falls under the 14:20:54

24 Federal Railway Administration. 14:20:59

25 Q. And the equipment, when you 14:21:00

2761960.txt

72

1 LOWELL MALO

2 talk about passenger safety standard -- 14:21:03

3 I'm sorry, passenger equipment safety, 14:21:05

4 what is the equipment they're talking 14:21:05

5 about? 14:21:07

6 A. Basic cars. 14:21:08

7 Q. A rail car's specific equipment 14:21:09

8 in this context? 14:21:11

9 A. Yes. 14:21:12

10 Q. So anything, the outside, the 14:21:12

11 inside, any part of the rail car? 14:21:15

12 A. Yes. 14:21:17

13 Q. Little different than intuitive, 14:21:18

14 equipment you think of something smaller 14:21:21

15 like, but in this context it's the whole 14:21:22

16 car? 14:21:26

17 A. Right, um hum. 14:21:26

18 Q. In a rail car what is the 14:21:34

19 biggest, in your experience -- among the 14:21:36

20 biggest, give it a one, two or three -- 14:21:40

21 safety concerns, things you want to 14:21:44

22 absolutely protect against as a priority, 14:21:47

2761960.txt

23 would you say? 14:21:51
24 A. Um hum. 14:21:52
25 You look at two main things: 14:21:53

73

1 LOWELL MALO

2 One is how to prevent an accident, and 14:21:55
3 then once things go really wrong how do 14:22:00
4 you minimize the damage. 14:22:03
5 Q. So in the first category what 14:22:07
6 are you trying to protect more than 14:22:09
7 anything else? 14:22:11
8 A. People. 14:22:12
9 Q. People's safety? 14:22:12
10 A. Um hum. 14:22:13
11 Q. And what are the biggest 14:22:14
12 concerns in a rail car, let's say a 14:22:17
13 subway car specifically that goes under- 14:22:20
14 ground. 14:22:23
15 A. Yeah. 14:22:24
16 Q. In terms of like people getting 14:22:27
17 hurt. 14:22:29
18 A. Yeah, um -- 14:22:30
19 Q. What are you trying to avoid 14:22:32

2761960.txt

20 going wrong? You have two categories, 14:22:33
21 things going wrong and if they go wrong 14:22:37
22 do something with it. 14:22:41
23 A. You want to make sure that 14:22:41
24 people cannot get their arms into things 14:22:42
25 that are dangerous. You want to make 14:22:45

74

1 LOWELL MALO

2 sure they don't bump their heads or bump 14:22:48
3 their shoulders just as best you can 14:22:52
4 walking through the car. 14:22:54
5 You do pay attention to fire 14:22:56
6 hazards, which is extremely important in 14:22:58
7 order for people to be safe. 14:23:01
8 Q. Is that one of the big problems 14:23:02
9 in an underground subway, fire? 14:23:04
10 A. Yes, it is, because there is no 14:23:06
11 place to go in a subway. 14:23:09
12 Q. Is that a common cause of 14:23:11
13 fatalities, fires? 14:23:13
14 A. It has been a cause of 14:23:14
15 fatalities. Is it any worse than 14:23:16
16 anything else? I don't know. 14:23:19

2761960.txt

17 Q. But one of them? 14:23:20
18 A. Yes. 14:23:21
19 Q. I'd like to direct your 14:23:28
20 attention to page 49745 of this document. 14:23:30
21 A. 745? 14:23:46
22 Q. Yes. 14:23:48
23 A. Okay. 14:23:49
24 Q. In the middle column it says 14:23:50
25 Train Internal Safety Features? 14:23:52

75

1 LOWELL MALO
2 A. Yes. 14:23:54
3 Q. Further down it says: "A 14:23:56
4 review of the accident/incident data, 14:23:57
5 related to fatalities and injuries on 14:24:00
6 passenger trains for the period of 1972 14:24:03
7 to 1973, indicates that collapse of 14:24:04
8 equipment structure and loss of 14:24:05
9 sufficient space for the passengers to 14:24:07
10 ride out the collision is a principal 14:24:09
11 cause of fatality in train accidents." 14:24:12
12 And then the next sentence it 14:24:15
13 goes on and talks about, it says: "Fire 14:24:17

2761960.txt

14 and post-collision conditions result in 14:24:19
 15 30 percent of the fatalities and 16 14:24:19
 16 percent of the serious injuries." 14:24:19
 17 Do you think that's reasonable, 14:24:25
 18 those numbers? 14:24:28
 19 A. In the '72 to '73 timeframe? 14:24:29
 20 Q. Yes. 14:24:33
 21 A. It could well be. 14:24:34
 22 Q. If we take a look at actually 14:24:45
 23 the page before, 49744, it talks about, 14:24:48
 24 the first column says fire safety. 14:24:54
 25 A. Um hum. 14:24:56

76

1 LOWELL MALO
 2 Q. You can read it to yourself but 14:24:58
 3 I'll start it. The first sentence says: 14:25:02
 4 "In 1984, FRA published guidelines 14:25:04
 5 recommending testing methods and 14:25:08
 6 performance criteria for the 14:25:10
 7 flammability, smoke emission, and fire 14:25:13
 8 endurance characteristics for categories 14:25:13
 9 and functions of materials to be used in 14:25:16
 10 the construction of new or rebuilt +rail 14:25:16

Page 85

2761960.txt

11 passenger equipment." 14:25:19

12 And it goes on and then it 14:25:22

13 says: "The intent of the guidelines is 14:25:25

14 to prevent fire ignition and to maximize 14:25:27

15 the time available for passenger 14:25:31

16 evacuation if fire does occur." 14:25:32

17 A. Yes. 14:25:35

18 Q. This is kind of consistent with 14:25:35

19 what you just said? 14:25:37

20 A. Um hum. 14:25:38

21 Q. You must have written this. 14:25:39

22 A. No. 14:25:40

23 Q. You did not write this. 14:25:41

24 Considering these guidelines on 14:25:42

25 safety and fire safety, how do design of 14:25:58

77

1 LOWELL MALO

2 TV monitors may be impacted by these 14:26:13

3 regulations and considerations that these 14:26:18

4 regulations are directed to in your mind? 14:26:22

5 A. Okay. The TV monitors are 14:26:25

6 subject to -- and it mentions some of the 14:26:28

7 testing in here, ASTM Event 160 -- well, 14:26:31

Page 86

2761960.txt

8 I can tell you what they are. 14:26:36
9 Q. Right. 14:26:37
10 A. There are three testing 14:26:37
11 procedures they have to follow, and the 14:26:39
12 idea is that the video screen itself 14:26:40
13 wouldn't melt and drip and start setting 14:26:46
14 fires below it, okay? 14:26:48
15 As far as, you know, does that 14:26:50
16 answer the question? 14:26:52
17 Q. Yes, no, go ahead, I'm 14:26:52
18 listening, yes. 14:26:55
19 A. Okay. 14:26:55
20 I mean that's just basically 14:26:56
21 what it does. It makes sure that it 14:26:57
22 cannot catch on fire and if it does it 14:26:59
23 does not have an open flame and spread, 14:27:02
24 and that's one of the drip criteria where 14:27:05
25 you have hot flame and stuff coming down 14:27:08

78

1 LOWELL MALO
2 to the carpets, going down to the seats, 14:27:10
3 coming down on people's heads. 14:27:14
4 Q. Are there any design features 14:27:16

2761960.txt

5 regarding the location and disposition of 14:27:19
6 TV monitors in subway cars that you think 14:27:21
7 would be impacted by these fire safety 14:27:28
8 guidelines and fire safety concerns? 14:27:33
9 A. You mean as far as location of 14:27:36
10 the monitors or -- 14:27:42
11 Q. Location of the monitors, yes. 14:27:43
12 A. Well, it is if the monitors are 14:27:45
13 part of the fire warning system, which is 14:27:56
14 a possibility, you would have to have 14:27:58
15 them in a place where you could see them 14:28:00
16 easily. 14:28:02
17 Q. Okay. 14:28:03
18 A. But in a rail car by the time 14:28:03
19 you're told to get out you already know 14:28:06
20 it, okay? 14:28:09
21 Q. Right. 14:28:09
22 A. The other thing you look at is 14:28:09
23 location of the monitors to make sure 14:28:12
24 that you can't spread the fire to 14:28:14
25 somewhere else. By then the monitor has 14:28:17

79

1

LOWELL MALO

Page 88

2761960.txt

2 already passed the smoke and flame test 14:28:19
3 and hopefully meets the criteria. 14:28:22
4 Q. Right. 14:28:24
5 What about the ventilation 14:28:25
6 monitors and the heating of these 14:28:27
7 monitors? 14:28:29
8 A. Um hum. 14:28:30
9 Q. How does that play into -- how 14:28:33
10 does the heating -- 14:28:38
11 MR. KEYHANI: Let's strike 14:28:39
12 that. 14:28:41
13 Q. How do the concerns about 14:28:41
14 heating of these monitors, ventilation of 14:28:44
15 these monitors play, for safety reasons, 14:28:47
16 play into the disposition of the 14:28:50
17 monitoring in the rail car? 14:28:51
18 A. We would have to take a look at 14:28:55
19 how much heat the monitor itself 14:28:56
20 generates and then see how we would 14:28:58
21 dissipate. If it was a number large 14:29:00
22 enough we would have to be able to 14:29:03
23 dissipate the heat. 14:29:05
24 Q. How would you dissipate that? 14:29:06
25 A. Sometimes just venting directly 14:29:07

1 LOWELL MALO

2 into the car, you know, that would be one 14:29:11

3 way of doing it. Some things, not 14:29:13

4 necessarily monitors, but lights, for 14:29:16

5 example, have a little tunnel behind it, 14:29:18

6 if you will, for air to pass through, and 14:29:20

7 it's just to bring cool air in to cool it 14:29:24

8 off. 14:29:28

9 Q. Are there fans behind or 14:29:28

10 somewhere around these monitors? 14:29:30

11 A. Generally no. 14:29:32

12 Q. What about do these monitors 14:29:33

13 have -- these TV monitors have 14:29:35

14 ventilation? 14:29:37

15 A. No more than the monitors 14:29:41

16 already have ventilation built into the 14:29:44

17 tops or the sides. 14:29:46

18 Q. How does that work? Are you 14:29:47

19 familiar with those types of designs? 14:29:48

20 A. It's just conventional heat, 14:29:48

21 heat comes out, there's no fans inside 14:29:50

22 generally. 14:29:53

2761960.txt

23 Q. Are there -- are there holes in 14:29:53
24 these monitors, TV monitors, for heat to 14:29:55
25 come out? 14:29:59

81

1 LOWELL MALO

2 A. I'm trying to think of specific 14:30:01
3 examples. 14:30:03

4 Q. In rail cars I'm talking about 14:30:04
5 in particular. 14:30:06

6 A. Okay. 14:30:07

7 Q. Well, let's look at TV monitors 14:30:07
8 generally. Are there -- are there holes 14:30:10
9 for heat to come out in TV monitors 14:30:14
10 generally, or should there be? 14:30:17

11 A. On the older style CRT 14:30:19
12 televisions, my own television had 14:30:22
13 ventilation on the back side, now that 14:30:25
14 it's flat screen I don't think there is 14:30:27
15 ventilation. 14:30:30

16 Q. Well, what about going back 14:30:31
17 from 1995 to 1997, the period that is the 14:30:32
18 subject of some of this prior art related 14:30:35
19 to the patent, what kind of TVs were 14:30:38

2761960.txt

20 there then? The kind of TV that you had? 14:30:40
21 A. Pardon? 14:30:44
22 Q. The kind of TV that you were 14:30:45
23 talking about? 14:30:48
24 A. They were getting into more of 14:30:48
25 the liquid crystal displays, which is 14:30:49

82

1 LOWELL MALO
2 very cool items, not quite into LEDs yet, 14:30:52
3 it was making -- it was making progress 14:30:56
4 towards much cooler units. 14:30:57
5 Q. Did the TVs in the 1990s have, 14:30:59
6 to your knowledge, have openings for 14:31:02
7 ventilation? 14:31:06
8 A. I'm not positive at the moment. 14:31:10
9 Q. It would make sense that they 14:31:16
10 would have that to make sure that they 14:31:19
11 don't overheat? 14:31:19
12 A. If that's the only way of 14:31:20
13 dissipating the heat. I mean, you could 14:31:22
14 dissipate the heat by heating the 14:31:24
15 enclosure around it without having heat. 14:31:28
16 Q. Are you familiar with any 14:31:30

Page 92

2761960.txt

17 federal regulations or guidelines related 14:31:33
 18 to safety in terms of heating of TV 14:31:36
 19 monitors, the kind of regulations we are 14:31:39
 20 talking about here? 14:31:42
 21 A. I'm not aware of one, there 14:31:47
 22 could well be, but I'm not aware of it. 14:31:49
 23 Q. Do you think that might be 14:31:51
 24 relevant to the understanding about how 14:31:54
 25 and where to place TV monitors in a rail 14:31:57

83

1 LOWELL MALO
 2 car that goes underground with passengers 14:31:59
 3 in it? 14:32:02
 4 A. I think it's more important 14:32:03
 5 that TV monitors be designed to dissipate 14:32:05
 6 the heat so you don't have special 14:32:08
 7 conditions; in other words, you dissipate 14:32:13
 8 the heat through a particular case or 14:32:14
 9 something like that. 14:32:16
 10 Q. And how would it do that? How 14:32:17
 11 would a TV monitor dissipate heat 14:32:19
 12 generally? 14:32:22
 13 A. Okay. Do it through an 14:32:23

2761960.txt

14 enclosure case, basically an aluminum 14:32:25
 15 heat sink. 14:32:28
 16 Q. I'm sorry, a what? 14:32:29
 17 A. You do it through an aluminum 14:32:29
 18 heat sink, just is a way of dissipating 14:32:28
 19 the heat that's all. 14:32:33
 20 Q. What about having openings in 14:32:35
 21 the monitor so that heat can escape the 14:32:39
 22 monitor, is that a reasonable way to deal 14:32:42
 23 with preventing overheating of the 14:32:46
 24 monitor? 14:32:48
 25 A. The downside when you have 14:32:48

84

1 LOWELL MALO
 2 openings is things that you don't want 14:32:50
 3 getting into the monitors. 14:32:52
 4 Q. Wasn't that always the case? 14:32:53
 5 A. Like dust and crap. My RCA 14:32:56
 6 once did. 14:33:02
 7 MR. KEYHANI: Please mark this 14:33:28
 8 as Patent Owner's Exhibit 8. 14:33:29
 9 (Whereupon, the above-mentioned 14:33:33
 10 Consumer Product Safety Commission 14:34:55

Page 94

2761960.txt

11 Guidelines Television Receiver Safety 14:34:55
 12 was marked Patent Owner Exhibit 8 for 14:34:55
 13 identification.) 14:34:09
 14 Q. Are you familiar with the 14:34:09
 15 Consumer Product Safety Commission? 14:34:10
 16 A. Yes. 14:34:12
 17 Q. Can you tell us what that is? 14:34:13
 18 A. It's a commission that just 14:34:14
 19 looks out for the safety and wellbeing of 14:34:16
 20 the consumer and public. 14:34:19
 21 Q. Is it concerned about, for 14:34:20
 22 example, safety of products that are in 14:34:24
 23 rail cars as well or items that are in 14:34:26
 24 rail cars? 14:34:31
 25 A. I am not aware of any time I've 14:34:33

85

1 LOWELL MALO
 2 ever seen a Consumer Product Safety 14:34:36
 3 indoors or checking anything in a rail 14:34:39
 4 car. 14:34:39
 5 Q. What about television monitors? 14:34:42
 6 A. Even television monitors. They 14:34:44
 7 may be, but I'm not aware of it. 14:34:47

Page 95

2761960.txt

8 Q. Take a look at this exhibit. 14:34:49

9 This is a public record of the Consumer 14:34:51

10 Product Safety Commission. 14:34:55

11 If you go to page 2 of this 14:35:06

12 document -- 14:35:09

13 A. If you don't mind I'd like to 14:35:09

14 just read through real quickly. 14:35:12

15 Q. Absolutely, of course. 14:35:17

16 (Witness peruses Patent Owner's 14:35:51

17 Exhibit 8.) 14:35:54

18 THE WITNESS: Okay. 14:37:02

19 Q. Looking at paragraph 10, for 14:37:03

20 example. 14:37:04

21 A. Um hum. 14:37:04

22 Q. It says, "TV sets are provided 14:37:05

23 with ventilation openings in the cabinet 14:37:07

24 to allow heat generated during the 14:37:07

25 operation to be released." 14:37:11

86

1 LOWELL MALO

2 You've testified to that. 14:37:14

3 "If these openings are blocked, 14:37:15

4 heat build-up within the TV can cause 14:37:17

2761960.txt

5 failures which may result in a fire 14:37:19
6 hazard." 14:37:19
7 Would you agree with that 14:37:23
8 statement? 14:37:25
9 A. Not only televisions but 14:37:26
10 anything with enough heat can be a fire 14:37:29
11 hazard. 14:37:31
12 Q. And therefore the commission 14:37:32
13 says -- states the following: 14:37:34
14 "Never cover the openings with 14:37:35
15 cloth or other material. 14:37:37
16 "Never block the bottom 14:37:39
17 ventilation slots of a portable TV by 14:37:41
18 placing it on a bed, sofa, rug, etc. 14:37:41
19 "Never place the set near or 14:37:43
20 over a radiator or heat register. 14:37:47
21 "Never place a set in a 14:37:49
22 'built-in' enclosure unless proper 14:37:52
23 ventilation is provided." 14:37:53
24 If you put a TV screen or 14:38:00
25 monitor into the wall of a rail car -- 14:38:03

87

1

LOWELL MALO

Page 97

2761960.txt

88

1 LOWELL MALO

2 monitor in the structure of the rail car? 14:39:16

3 MR. BILLAH: Objection. Calls 14:39:20

4 for speculation. Lack of foundation. 14:39:21

5 MR. KEYHANI: That's fine. 14:39:24

6 You can answer the question. 14:39:25

7 You have offered him as an 14:39:28

8 expert, that's what he has been doing 14:39:29

9 today. 14:39:31

10 THE WITNESS: That's okay. 14:39:32

11 Could you repeat that please, I guess. 14:39:33

12 MR. KEYHANI: Could you please 14:39:34

13 read the question. 14:39:36

14 (The requested portion of the 14:40:07

15 record was read.) 14:40:07

16 Q. Can you take a look at Exhibit 14:40:07

17 2, Namikawa. 14:40:09

18 A. Um hum. Where are we looking? 14:40:11

19 Q. Now, keeping that -- the 14:40:13

20 question is directed at this particular 14:40:18

21 exhibit so if you have an answer there is 14:40:20

22 a question pending -- 14:40:23

Page 99

2761960.txt

23 A. Um hum. 14:40:24

24 Q. -- but it's directed at this 14:40:24

25 exhibit. 14:40:26

89

1 LOWELL MALO

2 A. Okay. 14:40:26

3 Q. The question she just read. 14:40:27

4 A. Right. 14:40:29

5 So is it a fact that it should 14:40:33

6 be considered; is that the question? 14:40:35

7 Q. Yes. 14:40:37

8 A. Yes, it should be considered. 14:40:37

9 Q. Do you believe at the time of 14:40:39

10 the publication of Namikawa, which is 14:40:41

11 1992, and the application was filed, I'm 14:40:45

12 looking at Exhibit 2 on the front of it, 14:40:50

13 was filed in 1990 -- 14:40:52

14 A. Um hum. 14:40:53

15 Q. And the kind of TV's that 14:40:58

16 existed in 1990 -- 14:41:01

17 A. Um hum. 14:41:02

18 Q. -- would there have likely have 14:41:03

19 been ventilation through openings in the 14:41:07

2761960.txt

20 TV monitors at that time, 1990 and a 14:41:10
21 little bit prior to that, because that 14:41:13
22 was what presumably the inventors had to 14:41:15
23 look at and think about at that time? 14:41:18
24 A. There could well be, and this 14:41:20
25 provides very nicely for it [indicating]. 14:41:22

90

1 LOWELL MALO
2 Q. What does, you're looking at 14:41:24
3 Figure 1? 14:41:25
4 A. Yes. 14:41:25
5 Q. Could you explain what you're 14:41:26
6 pointing at? 14:41:27
7 A. Again, you have a slanted 14:41:28
8 surface here [indicating]. 14:41:32
9 Q. Yes? 14:41:33
10 A. That builds an opening or 14:41:33
11 cavity on the back side of the wall so it 14:41:35
12 gives you a place to ventilate. 14:41:38
13 Q. Where is the ventilation 14:41:39
14 happening? 14:41:41
15 A. It happens right behind the 14:41:41
16 back along with all the conduits and 14:41:43

Page 101

2761960.txt

17 wiring that runs along this part of the 14:41:47
18 car. 14:41:49
19 Q. I'm sorry, I'm looking at a 14:41:49
20 figure. 14:41:50
21 A. Yes. 14:41:50
22 Q. Are you pointing to something 14:41:51
23 that is not being shown in the figure? 14:41:52
24 A. See back here this corner where 14:41:54
25 it comes up here [indicating]? That 14:41:56

91

1 LOWELL MALO
2 doesn't exist down here. There is a 14:41:59
3 separate panel that runs at an angle down 14:42:01
4 this way out here that allows for the 14:42:04
5 mounting, allows for the television to 14:42:07
6 show down, so that empty space behind 14:42:10
7 that wall that's where this would 14:42:12
8 ventilate to. 14:42:15
9 Q. Looking at this Figure 1, 14:42:15
10 doesn't this appear that there's a 14:42:17
11 certain amount of width that is outside 14:42:20
12 of the wall that appears in this figure 14:42:21
13 here, on the monitor 12 in Figure 1? 14:42:23

2761960.txt

14 A. And the answer is yes, there is 14:42:28
15 a certain amount of monitor width. 14:42:30
16 Q. Could there be a ventilation 14:42:31
17 opening on the sides there? 14:42:34
18 A. Could be, um hum. 14:42:35
19 Q. That would be one way to cool 14:42:36
20 it off? 14:42:38
21 A. Yes, the, um -- 14:42:39
22 Q. I have another question. 14:42:42
23 A. Sure, go ahead. 14:42:43
24 Q. I wanted to take a look at 14:42:45
25 another reference, actually. 14:42:46

92

1 LOWELL MALO
2 What about Amano, if you could 14:42:48
3 pull out the Amano reference. 14:42:54
4 A. Um hum. 14:42:57
5 Q. Amano is Patent Owner's No. 3. 14:43:04
6 This patent was published in 14:43:09
7 1990, application is 1989. 14:43:12
8 A. Okay. 14:43:15
9 Q. At that time, 1989, circa 1989 14:43:16
10 or a little bit before then, 1988, 1999, 14:43:20

2761960.txt

11 would TV monitors at that time probably 14:43:24
12 be ventilated through holes in the TV, in 14:43:26
13 other words openings in the TV itself 14:43:29
14 where air could escape? 14:43:32
15 We could pull some other 14:43:37
16 literature if you want to look at it. 14:43:39
17 A. That's okay. 14:43:40
18 Probably, yes. Definitely, I 14:43:41
19 don't know. It depends on the unit. 14:43:44
20 Q. Go to Figure 5, for example 14:43:53
21 Figure 5 or Figure 6, this is on page 6. 14:43:58
22 A. Okay. 14:44:01
23 Q. The TV monitor appears to be 14:44:03
24 outside of the wall of these particular 14:44:07
25 figures; would you agree with that? 14:44:10

93

1 LOWELL MALO
2 A. That's what it appears to be, 14:44:11
3 yes. 14:44:13
4 Q. Could there be ventilation on 14:44:13
5 the sides of these monitors, openings, in 14:44:16
6 other words openings for air to come out 14:44:20
7 to avoid overheating? 14:44:22

2761960.txt

8 A. Could there be? Yes. 14:44:24

9 Q. Do you think there likely would 14:44:26

10 have been at this time? 14:44:29

11 A. That I can't tell you. 14:44:31

12 Q. Well, you are here to testify 14:44:32

13 about various aspects in your opinion. 14:44:35

14 A. Okay. 14:44:38

15 Q. Based on your knowledge and 14:44:38

16 design of these things, you were in this 14:44:40

17 business at the time in 1989 and 1990? 14:44:43

18 A. Yes. 14:44:44

19 Q. If there was going to be a TV 14:44:45

20 monitor disposed on a wall and you're 14:44:47

21 dealing with the technology of that era 14:44:52

22 at that time, would you likely want to 14:44:55

23 see some ventilation in that monitor and 14:44:58

24 how would that be done probably at that 14:45:02

25 time? 14:45:05

94

1 LOWELL MALO

2 MR. BILLAH: Objection. 14:45:05

3 Compound. 14:45:06

4 A. Okay. 14:45:08

2761960.txt

5 MR. KEYHANI: Let me ask the 14:45:08
6 first question, restate the question. 14:45:10
7 THE WITNESS: Go 'head. 14:45:12
8 Q. Would there likely be openings 14:45:12
9 in this TV monitor in Figure 5 and Figure 14:45:15
10 6 for ventilation purposes? 14:45:18
11 A. I'm not the person that 14:45:21
12 designed the television. 14:45:23
13 Q. No, I understand. 14:45:24
14 A. Okay. 14:45:26
15 Q. But you provided a lot of 14:45:26
16 testimony about a lot of figures -- 14:45:28
17 A. Yes. 14:45:29
18 Q. -- that you didn't draw or were 14:45:30
19 not part of your personal inventions or 14:45:31
20 disclosures so -- 14:45:34
21 A. I'm not seeing any ventilation 14:45:35
22 here. 14:45:37
23 Q. Okay. 14:45:38
24 It doesn't mean it's not there, 14:45:38
25 you just don't see it? 14:45:40

1 LOWELL MALO

2 Q. And a disclosure of around -- 14:46:27
3 that was disclosing, well, was applied 14:46:29
4 for in 1989, how do you believe that 14:46:32
5 these monitors were being ventilated? 14:46:35

6 A. A, they might not have had to 14:46:40
7 be ventilated; B, they could have done it 14:46:44
8 with heat tubes, which is a different way 14:46:46
9 of cooling. It's the way your computer 14:46:48
10 is cooled now. There are several 14:46:50
11 different ways to do it. 14:46:53

12 Q. What do -- what did your -- 14:46:54
13 what you believe is the way ventilation 14:46:55
14 was mostly done as one of ordinary skill 14:46:56
15 in the art would have probably done? 14:46:58

16 A. Let's see what type of monitor 14:47:00
17 it is. Yes, so this is back in 1990 and 14:47:02
18 they're talking about liquid crystal 14:47:28
19 displays, which was very low heat output. 14:47:30
20 I don't see any other monitor or type 14:47:45
21 called out here right off. 14:47:48

22 MR. KEYHANI: Is there a 14:49:06

2761960.txt

23 question pending, I'm sorry? 14:49:06
 24 THE REPORTER: No. 14:49:13
 25 Q. How about in Maekawa, which is 14:49:25

97

1 LOWELL MALO
 2 exhibit -- Maekawa -- Exhibit PO 6, take 14:49:29
 3 a look at this. 14:49:59
 4 How do you believe that the TV 14:50:05
 5 monitors in this patent were being 14:50:11
 6 ventilated? 14:50:17
 7 (Witness peruses Patent Owner's 14:50:30
 8 Exhibit 6.) 14:50:34
 9 A. I'm looking for the screen 14:50:43
 10 type. This refers to liquid crystal 14:51:37
 11 displays, which are very low heat. 14:51:41
 12 Q. Okay. 14:51:43
 13 And so is there no concern 14:51:44
 14 about ventilating liquid crystal 14:51:48
 15 displays? 14:51:51
 16 A. Generally, no. 14:51:52
 17 Q. So there's -- so do you have 14:51:55
 18 expertise in ventilation or proper 14:51:58
 19 ventilation of TV monitors? 14:52:01

2761960.txt

20 A. I'm a little confused because I 14:52:08
21 thought you just told me I did. 14:52:11
22 Q. I don't know if you do. I 14:52:13
23 don't know if you do. I'm talking about 14:52:15
24 ventilation of TV monitors generally; do 14:52:16
25 you have expertise in that? 14:52:19

98

1 LOWELL MALO

2 A. My expertise is if heat is 14:52:20
3 generated I know how to dissipate it; but 14:52:23
4 as far as the heat within the monitor, I 14:52:25
5 didn't design that. 14:52:29
6 Q. I guess are you -- do you 14:52:30
7 consider yourself qualified to testify 14:52:33
8 about what is the appropriate way for a 14:52:35
9 particular type of TV to be ventilated or 14:52:38
10 to avoid overheating? 14:52:41
11 A. I would say that if you told me 14:52:47
12 how much heat was generated I would be 14:52:50
13 qualified in dissipating the heat. 14:52:53
14 Q. Well, you just testified a 14:52:56
15 moment ago about a certain type of TV, 14:52:58
16 you said liquid crystal? 14:53:00

Page 110

2761960.txt

17 A. Yes. 14:53:02
18 Q. And you didn't think that that 14:53:03
19 needed to be ventilated? 14:53:04
20 A. Very, very low heat. 14:53:06
21 Q. What is your basis for that 14:53:09
22 statement; do you have any expertise? 14:53:11
23 A. It's just not TV's it's any 14:53:15
24 displays. The displays we have that use 14:53:19
25 LCDs we don't ventilate. 14:53:23

99

1 LOWELL MALO
2 Q. And you base that on what 14:53:26
3 conclusion? 14:53:27
4 A. Installation of LCDs in cars. 14:53:28
5 Q. Any particular expertise other 14:53:32
6 than installing them in cars? 14:53:34
7 A. Measuring heat output, making 14:53:38
8 sure they don't get too hot. 14:53:40
9 Q. Are you testifying today that 14:53:42
10 the guidelines on the Commission that we 14:53:44
11 just went over, the Consumer Product 14:53:45
12 Safety Commission, does not apply to, was 14:53:50
13 it crystal LCD TV; is that what you 14:53:54

2761960.txt

14 called it? 14:53:57

15 A. Liquid crystal display. 14:53:58

16 Q. So it doesn't apply to liquid 14:54:01

17 crystal display TV monitors? 14:54:03

18 A. I would say that the guidelines 14:54:07

19 are very good general guidelines, 14:54:10

20 ultra-safe guidelines. I think you would 14:54:15

21 not have these guidelines if you put a TV 14:54:17

22 in an aircraft or an automobile or a rail 14:54:21

23 car. 14:54:24

24 Q. Well, I have a very specific 14:54:26

25 question. I was asking with respect to 14:54:27

100

1 LOWELL MALO

2 liquid crystal display TVs. 14:54:29

3 A. Um hum. 14:54:32

4 Q. Are these guidelines that we 14:54:32

5 just discussed and went over, do they not 14:54:34

6 apply to those type of TVs, in your 14:54:37

7 opinion? I don't know if it's an expert 14:54:40

8 opinion, but in your opinion? 14:54:41

9 A. Generally speaking the heat is 14:54:43

10 so low that's being generated out of this 14:54:44

2761960.txt

11 you don't worry about it. We have much 14:54:47
 12 higher heat sources in a car besides a 14:54:51
 13 TV. 14:54:54

14 Q. With respect to what type of 14:55:21
 15 TVs would you then, in your opinion, be 14:55:22
 16 concerned about having not covered 14:55:27
 17 ventilation? 14:55:31

18 A. Any vacuum tube television. 14:55:32

19 Q. What other kind of televisions, 14:55:35
 20 televisions like a Namikawa type of 14:55:37
 21 television where it's not an LCD or 14:55:41
 22 liquid crystal display, as you say? 14:55:44

23 A. Generally LCD or liquid crystal 14:55:47
 24 displays, again very, very low heat. 14:55:51

25 Q. In your view? 14:55:53

101

1 LOWELL MALO

2 A. Yes. 14:55:54

3 Q. So what other kinds of TVs 14:55:55
 4 would you want to have ventilation 14:55:57
 5 through openings, in your opinion? 14:55:59

6 A. Again, rear projection 14:56:02
 7 television or any vacuum tube television 14:56:05

2761960.txt

8 would generate huge amounts of heat. 14:56:09
9 MR. KEYHANI: I'd like to ask 14:57:29
10 you to take a look at -- would you 14:57:31
11 take a look at Maekawa. 14:57:33
12 THE WITNESS: Okay. It's right 14:57:38
13 in front of me. 14:57:40
14 Q. What kind of a TV is disclosed 14:57:50
15 in Maekawa in the rail car display 14:57:54
16 monitor? 14:57:58
17 A. I believe it's also liquid 14:57:59
18 crystal. Let me look. Okay. This is 14:58:01
19 the television receivers are thin using 14:58:25
20 liquid crystal panels or the like. 14:58:28
21 Q. And so you don't think there 14:58:40
22 was concerns about heating for the same 14:58:41
23 reasons you discussed before in Maekawa 14:58:45
24 in terms of -- in terms of ventilation of 14:58:47
25 a TV monitor? 14:58:51

102

1 LOWELL MALO
2 A. Monitors, it appears to be very 14:58:55
3 small. No, I wouldn't worry about it. 14:58:57
4 Q. What about Miyajima, I'll give 14:58:59

Page 114

2761960.txt

5 you a moment to find it. 14:59:06

6 Miyajima looks like -- that's 14:59:11

7 Miyajima, Patent Owner's Exhibit 4, what 14:59:13

8 kind of monitor is Miyajima involved? 14:59:17

9 MR. BILLAH: Objection. 14:59:20

10 Outside the scope. 14:59:21

11 MR. KEYHANI: Actually he's 14:59:25

12 been testifying regarding the state 14:59:25

13 of art at the time, so you can go 14:59:28

14 ahead and testify. 14:59:30

15 MR. BILLAH: You can answer. 14:59:35

16 THE WITNESS: Pardon? 14:59:37

17 MR. BILLAH: You can answer. 14:59:38

18 MR. KEYHANI: You can answer 14:59:38

19 the question. 14:59:39

20 (Witness peruses exhibit.) 15:00:31

21 A. It says a pneumatic liquid 15:00:37

22 crystal display. 15:00:40

23 Q. Okay. 15:00:41

24 A. Is that what you were looking 15:00:42

25 at? 15:00:43

2761960.txt

2 Q. Yes, Claim 15 it says? 15:00:44

3 A. Yes. 15:00:45

4 Q. And that's the kind -- that's 15:00:46

5 the kind of display you have been talking 15:00:47

6 about? 15:00:49

7 A. Um hum. 15:00:49

8 Q. That you don't think requires 15:00:49

9 cooling? 15:00:52

10 A. In a thin film transistor if 15:00:52

11 you add heat you couldn't, it would melt. 15:00:56

12 Q. So this type monitoring would 15:00:58

13 not require -- would not require cooling? 15:01:01

14 A. The only one I can't speak to 15:01:06

15 is electron beam radiation braun tube, I 15:01:09

16 have not put that in. 15:01:13

17 Q. But the liquid crystal display 15:01:14

18 would not have had -- you would not have 15:01:17

19 had any concerns regarding overheating? 15:01:18

20 A. We would look at it. What 15:01:20

21 happens is we take a look at the unit, 15:01:22

22 take a look at the spec sheets on the 15:01:24

23 unit, see how much heat it generates, and 15:01:26

24 if it's a significant amount we address 15:01:29

25 it, if it's not a significant amount -- 15:01:31

1 LOWELL MALO

2 which I would suspect it's not -- you 15:01:33

3 don't have to do a whole lot with it. 15:01:36

4 And this appears -- all of 15:01:38

5 these are mounted clearly in the open so 15:01:41

6 you have good -- good just natural 15:01:46

7 convection. 15:01:48

8 Q. You mean they are not inside 15:01:50

9 the wall in the Miyajima? 15:01:53

10 A. That's not what it looks like, 15:01:55

11 yes. 15:01:57

12 Q. Looks like it is externally 15:01:57

13 mounted? 15:01:59

14 A. From what I can see here, you 15:02:00

15 don't show the other wall, but just what I 15:02:02

16 can see here. 15:02:05

17 Q. So because it is externally 15:02:06

18 mounted you don't have to worry about any 15:02:08

19 heating in this case? 15:02:11

20 A. It helps. 15:02:12

21 Q. Lessens the heating? Lessens 15:02:12

22 the overheating, I'm sorry. 15:02:15

2761960.txt

23 A. It increases the cooling. 15:02:17

24 Q. Fine. 15:02:18

25 If you go to page 3 of this 15:02:23

105

1 LOWELL MALO

2 patent. 15:02:25

3 A. Yes. 15:02:25

4 Q. What is marked as paragraph 12. 15:02:26

5 A. Okay. 15:02:27

6 Q. It says: "If the display 15:02:28

7 compromises a backlight, the display 15:02:31

8 device may comprise a means for supplying 15:02:37

9 a cooling air flow that cools the 15:02:37

10 backlight via a gap between with the 15:02:40

11 display and the inner wall of the 15:02:42

12 vehicle." 15:02:44

13 A. Okay. 15:02:45

14 Q. Doesn't this disclosure teach 15:02:46

15 cooling systems, a cooling system for the 15:02:50

16 monitor? 15:02:52

17 A. It says if you had a backlit 15:02:52

18 display, it teaches cooling for a backlit 15:02:57

19 display; but for a display that has no 15:03:00

2761960.txt

20 backlighting, it doesn't say anything 15:03:03
 21 about that. 15:03:05
 22 Q. Can you explain that, what do 15:03:06
 23 you mean a display that comprises a 15:03:09
 24 backlight what does that -- what does 15:03:12
 25 that mean? 15:03:14

106

1 LOWELL MALO
 2 A. Okay. There's a couple -- I 15:03:15
 3 don't know if it shows you any pictures 15:03:18
 4 -- yes, it does, right here -- Figure 2. 15:03:19
 5 Okay? 15:03:30
 6 Q. Yes. 15:03:32
 7 A. Okay. 15:03:33
 8 So it shows you here the film 15:03:33
 9 itself, the polarizing film and glass 15:03:38
 10 substrate; behind it it shows backlight 15:03:43
 11 that is 01p, for papa, that is the item 15:03:46
 12 that is generating heat. 15:03:50
 13 So in this case with this 15:03:51
 14 particular thing we look at heat 15:03:52
 15 dissipation, the answer is yes. 15:03:56
 16 Q. What about paragraph at the 15:04:06

2761960.txt

17 bottom of 12, Figure 23? Figure 23 on 15:04:08
 18 page 5. 15:04:14
 19 A. Okay. 15:04:14
 20 Q. Figure 23 is a schematic view 15:04:15
 21 -- Figure 23 is a schematic view 15:04:30
 22 illustrating a display device according 15:04:33
 23 to twelfth embodiment of the present 15:04:37
 24 invention. Here, cooling air that has 15:04:40
 25 passed through the cooling air passage 15:04:43

107

1 LOWELL MALO
 2 gap 03c is discharged to the exterior by 15:04:47
 3 an exhaust fan 09, directed to the 15:04:50
 4 exterior, from the ceiling of the vehicle 15:04:53
 5 carriage." 15:04:55
 6 Are you suggesting that the 15:04:57
 7 cooling system in this patent is only for 15:04:59
 8 -- being disclosed only for an embodiment 15:05:03
 9 with a backlight? 15:05:06
 10 A. That's what the patent says, 15:05:10
 11 but it also shows on 03c a cavity in the 15:05:11
 12 side wall that extends all the way to the 15:05:16
 13 side wall, around the junction and into 15:05:18

Page 120

2761960.txt

14 the ceiling. 15:05:22

15 Q. Where does it show a cavity in 15:05:28

16 the disclosure? 15:05:31

17 A. Okay, it says air flow 03c and 15:05:32

18 if you look again at picture 25 it even 15:05:35

19 has a little arrow showing the air flow 15:05:38

20 coming up through the side wall. 15:05:41

21 Q. Figure 23 you mean? 15:05:43

22 A. I was referring to 03c, the 15:05:45

23 item number. Is that 3 or 5? I don't 15:05:47

24 know. 15:05:49

25 Q. Figure 23? 15:05:49

108

1 LOWELL MALO

2 A. Okay. 15:05:50

3 So let's go back here and see 15:05:51

4 the definition. Boy, I need better 15:05:54

5 glasses. 15:06:14

6 Q. Are you saying Figure 23 does 15:06:17

7 not have a cooling system or does? 15:06:20

8 A. Oh, it does. 15:06:22

9 Q. Okay. 15:06:23

10 Why would it need a cooling 15:06:25

2761960.txt

11 system if it's a crystal LCD as you're 15:06:27
12 describing? 15:06:33
13 A. Because you have backlighting. 15:06:33
14 Q. Where does it say that Figure 15:06:34
15 23 has backlighting? 15:06:36
16 These are various embodiments; 15:06:39
17 correct? 15:06:41
18 A. Yes, embodiments, I guess, 15:06:42
19 yeah. I don't think in terms of legal 15:06:46
20 terms, sorry. 15:06:48
21 Q. That's okay. 15:06:50
22 A. Which one -- what paragraph 15:06:53
23 were we looking at before, the last 15:06:55
24 paragraph? 15:06:58
25 Q. Page 5, Figure 23, paragraph -- 15:06:58

109

1 LOWELL MALO
2 embodiment 12. We were looking at a 15:07:01
3 different embodiment. We were on page 3, 15:07:05
4 now we're on a different embodiment; 15:07:14
5 we're on page 5, embodiment 12. 15:07:15
6 A. Well, let's take a step back 15:07:18
7 here. Yeah, heater cooling is different 15:07:22

2761960.txt

8 from embodiment 12. 15:07:30

9 Q. What page are you on? 15:07:32

10 A. I'm on page 5, embodiment 12. 15:07:33

11 Q. Yes. 15:07:36

12 A. Okay. 15:07:37

13 This is "a schematic view 15:07:37

14 illustrating a display device according 15:07:39

15 to the twelfth embodiment of the present 15:07:39

16 invention. Here, cooling air that has 15:07:44

17 passed through the cooling air passage 15:07:46

18 gap 03c is discharged to the exterior by 15:07:50

19 exhaust fan 09, directed to the exterior, 15:07:53

20 from the ceiling of the vehicle carriage." 15:07:57

21 If you look at Figure 23 you 15:08:01

22 will see a path of air that's going 15:08:02

23 through the cavity in the wall, up 15:08:05

24 through the junction of the wall to the 15:08:07

25 ceiling, over to the roof and out. 15:08:08

110

1 LOWELL MALO

2 So you previously asked me was 15:08:18

3 there anything in the wording that shows, 15:08:20

4 but this picture and embodiment does. Now 15:08:21

2761960.txt

5 I have to go back and say that it even 15:08:25
6 says. 15:08:28
7 Q. I'm sorry, what? 15:08:28
8 A. And the embodiment that we were 15:08:29
9 just looking at, 12, even stated 15:08:30
10 that there was -- was it 12? I'm getting 15:08:32
11 confused here. I think it's via a gap 15:08:38
12 between the display in the inner wall of 15:08:48
13 the vehicle, so that air is flowing 15:08:51
14 through a gap in and out of the walls 15:08:57
15 through a cavity. 15:08:59
16 Q. Is that really between the 15:09:00
17 inner and outer wall? Is 03 an inner 15:09:02
18 wall or is that just the outer wall? 15:09:06
19 A. 03 is the passage. 15:09:08
20 Q. No, 03 in Figure 23, what is 15:09:10
21 that? 15:09:12
22 A. I am looking -- 15:09:13
23 Q. Isn't that the inner wall? 15:09:14
24 A. Just a minute. 15:09:16
25 03a is the curved part of the 15:09:25

2761960.txt

2 inner wall. 15:09:28

3 Q. Yes. 15:09:29

4 A. B is the glass. C -- 03c is 15:09:29

5 the cooling air passage gap. 15:09:33

6 Q. So 03 is actually an inner 15:09:51

7 wall, it's not an exterior wall; correct? 15:09:54

8 A. Let me see here, C what. 03a 15:10:09

9 is a curved part of the inner wall. 15:10:27

10 Q. Exactly. 15:10:29

11 A. Of the passage. 15:10:30

12 Q. That's correct. 15:10:31

13 So they're not talking about an 15:10:32

14 exterior wall, they're just talking about 15:10:33

15 -- isn't this just a monitor on top of the 15:10:36

16 interior wall in the interior part of the 15:10:40

17 passenger car and not -- there is no 15:10:44

18 exterior wall involved here? 15:10:46

19 A. I'm not clear how we can draw 15:10:50

20 that conclusion. 15:10:53

21 Q. Is there any reference to an 15:10:54

22 exterior wall anywhere? 15:10:56

23 A. Outside of the picture -- I'm 15:10:58

24 sorry, I didn't let you finish. 15:11:01

25 Q. That's okay. 15:11:03

1 LOWELL MALO

2 Anywhere in this specification. 15:11:04

3 A. No, but there is -- there is a 15:11:06

4 reference to an air passage, and an air 15:11:08

5 passage has to be bounded by two 15:11:11

6 somethings. 15:11:14

7 Q. Right, that could just be the 15:11:14

8 structure of the TV monitor being put 15:11:16

9 into the interior of -- 15:11:19

10 A. Except the air flow goes beyond 15:11:22

11 the TV monitors. If you look at the 15:11:25

12 little arrows, especially as it comes 15:11:28

13 through here, and you're on the roof, 15:11:30

14 it's going into the gap between the 15:11:32

15 outside roof and the inner roof. 15:11:35

16 Q. I see that. 15:11:37

17 It explicitly states though 15:11:37

18 that 03 is the interior wall. 15:11:40

19 A. Okay. 15:11:43

20 Q. Okay. 15:11:43

21 Is there any reference to an 15:11:53

22 exterior wall anywhere in this patent 15:11:54

2761960.txt

23 disclosure which is labeled as the Patent 15:11:57
 24 Owner's 4, Miyajima? 15:12:03
 25 A. 03 refers to vehicle carriage, 15:12:24

113

1 LOWELL MALO
 2 which appears to be the carousel that's 15:12:32
 3 pointing to the exterior. 15:12:37
 4 Q. It does specifically say that 15:12:38
 5 03 is the interior wall though; correct? 15:12:40
 6 A. It says 03 -- let's see now -- 15:12:43
 7 03a is the curved part of the inner wall 15:12:49
 8 of the carriage. 15:12:53
 9 Q. Correct. 15:12:53
 10 A. 03 is the vehicle carriage 15:12:53
 11 itself, and 03c is the cooling air 15:12:57
 12 passage gap. 15:13:01
 13 And also in Figure 2 here it 15:13:16
 14 does show the vehicle carriage as being 15:13:18
 15 outside of the air passage gap and the 15:13:21
 16 interior wall is back here someplace 15:13:25
 17 (indicating) so that gap is between the 15:13:27
 18 interior wall and the exterior wall. 15:13:29
 19 Q. But, again, there's no 15:13:31

2761960.txt

20 disclosure in the specification, the 15:13:32
21 verbiage of this about a cavity between 15:13:35
22 an interior and exterior wall, is there? 15:13:37
23 You're looking at the figures, 15:13:40
24 I understand that, but you testified 15:13:42
25 earlier -- and I just want to make sure 15:13:43

114

1 LOWELL MALO
2 that I got the testimony correct -- is 15:13:45
3 there any disclosure in the verbiage and 15:13:47
4 the language of this disclosure that 15:13:49
5 there is a cavity between an exterior and 15:13:50
6 an interior wall? 15:13:53
7 A. Yes. 15:13:54
8 Q. Okay. 15:13:55
9 A. It says air passage gap -- 15:13:55
10 cooling air passage gap. 15:13:59
11 Q. And the discussion about -- 15:14:02
12 where is that? 15:14:04
13 A. It's on page 6 under the 15:14:06
14 definitions of what θ -- of what θ_{3c} is. 15:14:10
15 Q. I'm sorry, where? 15:14:16
16 A. It's on page 6. 15:14:17

2761960.txt

17 Q. What is it, three what? 15:14:25
 18 A. 3c, 03c. 15:14:26
 19 Q. It says a cooling air passage 15:14:31
 20 gap. That is -- that is proof to you 15:14:34
 21 that there is a cavity between the 15:14:38
 22 exterior and internal walls of the rail 15:14:40
 23 car? 15:14:46
 24 A. Yes, how would air flow. 15:14:46
 25 Q. Would it have to be air flowing 15:14:48

115

1 LOWELL MALO
 2 between an exterior wall and interior 15:14:50
 3 wall? Couldn't it just be a compartment 15:14:52
 4 that's added on to the interior of the -- 15:14:54
 5 of the rail car and create a gap? 15:14:57
 6 Does it have to dig into -- 15:15:00
 7 does that -- does that mean that it has 15:15:00
 8 to dig into -- it has to be embedded into 15:15:02
 9 the wall of the rail car because there is 15:15:05
 10 a gap? 15:15:07
 11 A. I'm just giving my observation 15:15:09
 12 on what the picture shows. 15:15:11
 13 Q. I understand about the picture, 15:15:13

Page 129

2761960.txt

14 but a reference to -- but a reference 15:15:15
15 that you're talking about, a cooling air 15:15:17
16 passage gap, are you stating that that -- 15:15:19
17 does that allow you to conclude or that's 15:15:23
18 an indication that there's a -- that the 15:15:26
19 monitor is -- that there's a cavity 15:15:28
20 embedded in the wall -- 15:15:31
21 A. Yes. 15:15:33
22 Q. -- of the rail car? 15:15:33
23 A. Yes. 15:15:35
24 Q. And how do you come to that 15:15:35
25 conclusion? 15:15:37

116

1 LOWELL MALO
2 A. Because there is a hollow void, 15:15:38
3 that's what a gap is, that allows air to 15:15:41
4 flow through it, which means there's 15:15:44
5 nothing else there. 15:15:46
6 Q. Does that mean that that cavity 15:15:47
7 has to be within the wall between the -- 15:15:50
8 between the inner wall and an exterior 15:15:54
9 wall of the rail car? 15:15:58
10 Could it not just be a 15:16:00

Page 130

2761960.txt

11 structure on top of the interior wall 15:16:04
 12 that creates a gap between the interior 15:16:07
 13 wall and the structure? 15:16:10
 14 A. Not by this figure. 15:16:13
 15 Q. Doesn't 03 -- isn't that an 15:16:15
 16 indication in the figure as the interior 15:16:20
 17 wall, looking at Figure 23? 15:16:22
 18 A. Okay. 15:16:24
 19 Q. Isn't 03 -- isn't that the 15:16:25
 20 interior wall? 15:16:28
 21 A. No. 15:16:29
 22 Q. It's not? 15:16:29
 23 A. 03 is the vehicle carriage, I 15:16:30
 24 believe they use the term. 15:16:32
 25 Q. Okay, but 03c, isn't that the 15:16:33

117

1 LOWELL MALO
 2 interior wall? 15:16:36
 3 A. No, that's the air gap, that's 15:16:37
 4 the air flow gap that goes through. 15:16:38
 5 Here's -- here's -- here's the 15:16:42
 6 explanation (indicating). Okay? 03 is 15:16:43
 7 the vehicle carriage. 03a is the curved 15:16:49

Page 131

2761960.txt

8 part of the inner walls of the carriage. 15:16:53
9 03b is the transparent glass part and 03c 15:16:56
10 is the cooling air passage gap. 15:17:00
11 Q. I direct your attention to page 15:17:04
12 3. 15:17:06
13 A. Okay. 15:17:06
14 Q. Paragraph 12. 15:17:07
15 It says the display device -- 15:17:13
16 if the display compromises a backlight -- 15:17:18
17 and we read this before -- if the display 15:17:21
18 devise comprises a means for supplying a 15:17:25
19 cooling air flow that cools this 15:17:27
20 backlight via gap between the display and 15:17:29
21 the inner wall of the vehicle; where is 15:17:31
22 the exterior wall? 15:17:35
23 Isn't that an explicit 15:17:39
24 statement that the cooling air is between 15:17:41
25 the display and the inner wall of the 15:17:43

118

1 LOWELL MALO
2 vehicle, Mr. Malo? 15:17:45
3 A. Let's take a look at the 15:17:46
4 picture. 15:17:47

2761960.txt

5 Q. I'm reading that explicitly, 15:17:47
6 what it says. It says a cooling air flow 15:17:50
7 that cools this backlight via a gap 15:17:52
8 between the display and the inner wall of 15:17:55
9 the vehicle, okay? 15:17:58

10 A. Um hum. 15:17:58

11 Q. So there's the gap we're 15:17:59
12 talking about, right, and the cooling air 15:18:01
13 is between the gap and the inner wall; 15:18:04
14 correct? 15:18:06

15 A. I'm thinking we might have more 15:18:07
16 than one explanation here. We are going 15:18:10
17 to have to go through this in a lot more 15:18:11
18 detail. 15:18:14

19 Q. Doesn't talk about an exterior 15:18:15
20 wall, does it? 15:18:17

21 THE VIDEOGRAPHER: Counsel, be 15:18:20
22 advised I have to stop this in nine 15:18:22
23 minutes for the cards. 15:18:24

24 MR. KEYHANI: No problem. 15:18:26

25 You can go ahead. I have a 15:18:27

2761960.txt

2 question pending. 15:18:28
3 THE WITNESS: Okay. 15:18:30
4 MR. KEYHANI: Can you read my 15:18:31
5 question pending. 15:18:32
6 (The requested portion of the 15:18:50
7 record was read.) 15:18:53
8 A. In 12 it does not say anything 15:18:53
9 about an exterior wall. 15:18:58
10 Q. Doesn't it explicitly state and 15:18:59
11 explain the cooling air is between the 15:19:02
12 gap between the display and the inner 15:19:04
13 wall; doesn't that explicitly state that? 15:19:06
14 A. Well, what I have to do is go 15:19:09
15 back and read all of these others now and 15:19:11
16 find out if it's just an alternate 15:19:13
17 application; in other words, that's just 15:19:15
18 another way of doing it, because within 15:19:18
19 this thing here -- 15:19:20
20 Q. I've asked you before -- 15:19:21
21 A. Okay. 15:19:22
22 Q. -- if there is any reference to 15:19:22
23 any exterior wall, and let's start there, 15:19:24
24 is there any reference to any exterior 15:19:26
25 wall -- any cooling air going between an 15:19:28

1 LOWELL MALO

2 inner wall and exterior wall in this 15:19:31

3 specification. And you're welcome to 15:19:33

4 look at it, but that's the question. 15:19:38

5 A. I'm trying to think of a way to 15:19:46

6 answer this differently. 15:19:48

7 Q. Well, I'm not -- we're not 15:19:49

8 trying to dance around here. I just want 15:19:51

9 to know if this specification -- we are 15:19:53

10 looking at a very specific document -- is 15:19:55

11 there any disclosure or teaching or 15:19:57

12 description of cooling air going between 15:20:00

13 an inner wall and an exterior wall. 15:20:03

14 We know -- we know that there 15:20:05

15 is explicitly a description of cooling 15:20:06

16 air going between the display and the 15:20:09

17 inner wall, there is no question about 15:20:12

18 that; correct? Right? 15:20:14

19 A. Okay. 15:20:14

20 Q. Is that correct? 15:20:15

21 There is no question that this 15:20:16

22 specification discloses cooling air going 15:20:17

2761960.txt

23 between a display and an inner wall; is 15:20:20
 24 that correct? 15:20:23
 25 A. In paragraph 12, section 15:20:25

121

1 LOWELL MALO

2 reference 12 that's what it says. 15:20:29
 3 Q. Right, would you agree with 15:20:30
 4 that? 15:20:32
 5 A. Let me read it one more time. 15:20:32
 6 Which one was it now? That's not what 15:20:47
 7 this says. 15:20:50
 8 Q. Page 3, paragraph 12? 15:20:50
 9 A. Okay, thank you. 15:20:52
 10 MR. KEYHANI: Could you read my 15:20:53
 11 question that's pending again, 15:20:54
 12 please. 15:20:57
 13 (The requested portion of the 15:21:37
 14 record was read.) 15:21:38
 15 A. In that paragraph, yes. 15:21:38
 16 Q. Is there any disclosure in this 15:21:40
 17 specification of cooling air going 15:21:42
 18 between an inner wall and an external 15:21:44
 19 wall, that's the other question. 15:21:47

2761960.txt

20 A. Again, I'm going to go back to 15:21:52
21 Figure 23. 15:21:55
22 Q. Okay, but there is no 15:21:55
23 verbiage -- there is no verbiage in here 15:21:57
24 or any language disclosing any other flow 15:21:59
25 of cooling air between an inner wall and 15:22:03

122

1 LOWELL MALO
2 external wall. If there is, point it to 15:22:06
3 me; otherwise, let me know that there 15:22:10
4 isn't any. And you're welcomed to review 15:22:11
5 the specification. 15:22:14
6 A. Let me see about what 15:22:15
7 reference 23 is. 15:22:18
8 Again, I have to go back to 15:23:48
9 Figure 23, embodiment 12. 15:23:50
10 Q. So there is no disclosure in 15:23:52
11 the verbiage or language that 15:23:54
12 contradicts, that's different than the 15:23:55
13 fact that there's cooling air going 15:23:58
14 between the inner -- between the display 15:24:00
15 and the inner wall? Other than that 15:24:03
16 disclosure there is no other disclosure 15:24:06

Page 137

2761960.txt

17 regarding the flow of air, of cool air, 15:24:08
18 in the verbiage of the specification; is 15:24:13
19 that correct? 15:24:16
20 A. If we ignore Figure 23, yes. 15:24:17
21 Q. My question is about the 15:24:19
22 verbiage. 15:24:21
23 A. Okay. 15:24:22
24 Q. I understand you have opinions 15:24:22
25 regarding the figure and you're right, 15:24:24

123

1 LOWELL MALO
2 I'm asking the question about, you have a 15:24:26
3 right to testify about that or have 15:24:29
4 opinions on that. 15:24:31
5 A. Um hum. 15:24:31
6 Q. But my question is in the 15:24:32
7 verbiage of the specification there is no 15:24:34
8 disclosure of a cavity between an inner 15:24:36
9 wall and an external wall, there only is 15:24:38
10 a disclosure of a gap between a display 15:24:42
11 and an inner wall; is that correct? 15:24:45
12 A. In the verbiage. 15:24:51
13 Q. That is correct? 15:24:52

2761960.txt

14 A. Um hum. 15:24:53
15 Q. I'm sorry, you have to answer 15:24:53
16 yes or no. 15:24:55
17 A. Yes, I'm sorry, I apologize. 15:24:55
18 MR. KEYHANI: I have no further 15:24:57
19 questions right now unless I have to 15:24:59
20 -- unless I do a redirect or re-cross 15:25:00
21 after redirect. 15:25:02
22 Do you have some -- do you have 15:25:02
23 some cross? 15:25:04
24 MR. BILLAH: I might. 15:25:05
25 Why don't we take a break and -- 15:25:06

124

1 LOWELL MALO
2 THE VIDEOGRAPHER: I have to 15:25:09
3 take us off. 15:25:11
4 MR. BILLAH: Okay. 15:25:11
5 THE VIDEOGRAPHER: We are now 15:25:12
6 off the record. The time on the 15:25:12
7 video monitor is 3:24 p.m. 15:25:14
8 (Whereupon, a brief recess was 15:32:54
9 taken.) 15:33:20
10 THE VIDEOGRAPHER: We are now 15:33:20

2761960.txt

11 on the record. The time on the video 15:33:25
12 monitor is 3:33 p.m. 15:33:27
13 EXAMINATION BY MR. BILLAH: 15:33:27
14 Q. Lowell, can you take a look 15:33:32
15 back at what was marked Patent Owner's 15:33:34
16 Exhibit 2, which is Namikawa? 15:33:37
17 A. 02? 15:33:38
18 Q. Yes. 15:33:41
19 A. Yes. 15:33:41
20 Q. And can you flip to the figure 15:33:45
21 we've been referring to throughout the 15:33:48
22 day, Figure 1. 15:33:50
23 A. Yes. 15:33:50
24 Q. Do you recall Patent Owner's 15:33:55
25 counsel asking you prior questions about 15:33:59

125

1 LOWELL MALO
2 ventilation for TVs? 15:34:01
3 A. Yes. 15:34:03
4 Q. Looking at the drawing, Figure 15:34:04
5 1 in Namikawa, if you assume that the 15:34:08
6 television disclosed here required 15:34:11
7 ventilation, how could you completely 15:34:14

2761960.txt

8 flush-mount the TVs with the side walls 15:34:16

9 and provide for ventilation for the TVs? 15:34:20

10 MR. KEYHANI: Objection. Form. 15:34:24

11 MR. BILLAH: You can answer the 15:34:28

12 question. 15:34:29

13 THE WITNESS: Okay. 15:34:29

14 A. You could ventilate the 15:34:29

15 televisions back behind the wall. In 15:34:33

16 other words it can be set in -- actually 15:34:38

17 I would have taken the side wall, come 15:34:40

18 straight down, ventilate back into that 15:34:43

19 area behind the wall. 15:34:46

20 Understand in ventilation you 15:34:47

21 just have to give an area for the heat to 15:34:49

22 dissipate. You don't actually have to 15:34:52

23 send the heat outside. It just has to 15:34:55

24 dissipate. 15:34:58

25 MR. BILLAH: Pass the witness. 15:35:00

126

1 LOWELL MALO

2 MR. KEYHANI: I have no further 15:35:03

3 questions. 15:35:05

4 MR. BILLAH: Okay. 15:35:06

2761960.txt

5 I just have a couple of 15:35:07
6 notations for the record. 15:35:09
7 We will take a 30-day read and 15:35:10
8 sign, and I just want to note that or 15:35:12
9 Kawasaki wishes to note that for 15:35:15
10 what's been marked as Patent Owner's 15:35:18
11 Exhibit 1, which is the Supplemental 15:35:23
12 Expert Declaration of Lowell Malo -- 15:35:25
13 MR. KEYHANI: Yes. 15:35:30
14 MR. BILLAH: -- we are 15:35:30
15 correcting the citations in paragraph 15:35:32
16 12, the citations to Exhibit 1004 15:35:36
17 should be to Exhibit 1011, Sasao. 15:35:40
18 That's it. 15:35:46
19 MR. KEYHANI: I object to 15:35:50
20 attorney testimony regarding the 15:35:51
21 declaration on the record in this 15:35:53
22 deposition. 15:35:55
23 That's it. 15:35:58
24 [Continued on following page to 15:35:58
25 include signature line/jurat clause.] 15:35:58

2761960.txt

2 15:35:59

3 THE VIDEOGRAPHER: Okay. 15:35:59

4 We are now off the record. 15:35:59

5 The time on the video monitor 15:36:01

6 is 3:35 p.m. 15:36:03

7

8 _____
LOWELL MALO

9

10 _____
 11 Subscribed and sworn to
 12 before me this _____
 13 day of _____,
 14 2017

13

14 _____
Notary Public

15

16

17

18

19

20

21

22

23

24

25

1
2
3
4
5
6
7
8
9
10
11
12
13
14
15
16
17
18
19
20
21

C E R T I F I C A T I O N

I, KATHLEEN PIAZZA LUONGO, a
Notary Public for and within the State of
New York, do hereby certify that the
foregoing witness, LOWELL MALO, was duly
sworn on the date indicated, and that the
foregoing is a true and accurate
transcription of my stenographic notes.

I further certify that I am not
employed by nor related to any party to
this action.

<%signature%>

KATHLEEN PIAZZA LUONGO

2761960.txt

22
23
24
25

129

1

I N D E X

2
3

WITNESS

4
5

Lowell Malo

6

EXAMINATION BY

PAGE

7
8
9

Mr. Keyhani

6-123

Mr. Billah

124-126

10

11

E X H I B I T S

12
13

PATENT OWNER'S

DESCRIPTION

PAGE

14
15
16

Exhibit 1

Supplemental Expert
Declaration of
Lowell Malo

26

17

2761960.txt

18	Exhibit 2	Namikawa document	31
19			
20	Exhibit 3	Amano document	36
21	Exhibit 4	Miyajima document	38
22			
23	Exhibit 5	Sasao document	40
24	Exhibit 6	Miyajima document	41
25			

130

1

2 [Cont'd.]

3	PATENT OWNER'S	DESCRIPTION	PAGE
---	----------------	-------------	------

4	Exhibit 7	proposed FRA regulations document	65
5			
6			

7	Exhibit 8	Consumer Product Safety Commission Guidelines Television Receiver Safety	84
8			
9			

10 EXHIBITS RETAINED BY COURT REPORTER

11

12

13

2761960.txt

14
15
16
17
18
19
20
21
22
23
24
25

131

1
2
3
4
5
6
7
8
9

LITIGATION SUPPORT INDEX

DIRECTION TO WITNESS NOT TO ANSWER

Page	Line	Page	Line
------	------	------	------

(NONE)

REQUEST FOR PRODUCTION OF DOCUMENTS

Page	Line
------	------

Page 147

2761960.txt

10

(NONE)

11

12

INFORMATION TO BE FURNISHED

13

14

Page Line

15

16

(NONE)

17

QUESTIONS MARKED FOR A RULING

18

Page Line Page Line

19

20

(NONE)

21

22

23

24

25

132

1

ERRATA SHEET
VERITEXT/NEW YORK REPORTING, LLC
1-800-727-9396

2

3

200 OLD COUNTRY ROAD 1350 BROADWAY
MINEOLA, NEW YORK 11501 NY, NY 10018

4

5

NAME OF CASE:

2761960.txt

DATE OF DEPOSITION:

6 NAME OF DEPONENT:

7

8	PAGE	LINE(S)	CHANGE	REASON
9	_____	_____	_____	_____
10	_____	_____	_____	_____
11	_____	_____	_____	_____
12	_____	_____	_____	_____
13	_____	_____	_____	_____
14	_____	_____	_____	_____
15	_____	_____	_____	_____
16	_____	_____	_____	_____
17	_____	_____	_____	_____
18	_____	_____	_____	_____

19 _____
(NAME OF WITNESS)

21 SUBSCRIBED AND SWORN TO BEFORE ME
22 THIS ____ DAY OF _____, 20__.

23 _____ MY COMMISSION EXPIRES:
(NOTARY PUBLIC)

24

25

EXHIBIT 2006- 150
DEPOSITION MALO EXHIBIT 1
**UNITED STATES PATENT AND TRADEMARK OFFICE
BEFORE THE PATENT TRIAL AND APPEAL BOARD**

KAWASAKI RAIL CAR, INC.
Petitioner,

v.

SCOTT BLAIR,
Patent Owner.

Case No. IPR2017-00117

Patent No. 6,700,602

Issue Date: March 2, 2004

Title: Subway TV Media System

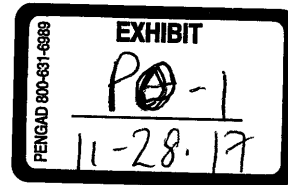

**SUPPLEMENTAL EXPERT DECLARATION OF
LOWELL MALO**

I. INTRODUCTION

1. I, Lowell Malo, have been retained by counsel for Kawasaki Rail Car, Inc. (hereinafter “Petitioner”).
2. I submit this declaration in support of Petitioner’s Petition for *Inter Partes* Review of U.S. Pat. No. 6,700,602, No. IPR2017-00117.

II. QUALIFICATIONS

3. I am currently Vice President of Engineering Services for RailPlan International Inc.
4. I have previously summarized in my original declaration (Ex. 1014) my background, education, and professional experience.

III. MATERIALS CONSIDERED

5. I have reviewed the following:
 - a. U.S. Pat. No. 6,700,602 (“the ’602 Patent”) including the claims thereof;
 - b. The translation of Japanese Publication No. 04-085379 (Ex. 1005, “Namikawa”);
 - c. The translation of Japanese Publication No. 04-322579 (Ex. 1011, “Sasao”);
 - d. Patent Owner Scott Blair’s Response (Paper No. 13) (“Response”);
 - e. Expert Declaration of Jack Long (Ex. 2002);

f. Supplemental Declaration of Jack Long (Ex. 2004).

6. In making my conclusions stated herein, while reviewing the materials listed in paragraph 5, I have applied the claim construction definitions applied by Petitioner in its Reply to Patent Owner Scott Blair's Response (unless otherwise indicated herein).
7. I understand that a claim is invalid for obviousness if the differences between the subject matter sought to be patented and the prior art are so insubstantial that the subject matter as a whole would have been obvious, at the time the invention was made, to a person having ordinary skill in the art to which that subject matter pertains.
8. To the best of my understanding, my opinions regarding obviousness of the '602 Patent follow the legal principles contained in *Graham v. John Deere*, 383 U.S. 1 (1966) and *KSR Int'l Co. v. Teleflex, Inc.*, 550 U.S. 398 (2007).

IV. OPINIONS

A. Namikawa and Sasao

9. The Response states that "Nothing within the teachings of Namikawa teaches or suggests the availability of space beyond the wall, let alone the availability of space beyond the wall at the junction of the sidewall and the ceiling to allow for the screen of the monitor to be substantially flushed with the adjacent wall surface structure of the car." (Response at 6). The

Response also states that “Still further, nothing within the teachings of Namikawa teaches or suggests the availability of space beyond the wall, let alone the availability of space beyond the wall at the junction of the sidewall and the ceiling to allow for the screen of the monitor to be substantially flushed with the adjacent wall surface structure of the car.” (Response at 20-21). Mr. Long states that “Nothing within the teachings of Namikawa teaches or suggests the availability of space beyond the wall, let alone the availability of space beyond the wall at the junction of the sidewall and the ceiling to allow for the screen of the monitor to be substantially flushed with the adjacent wall surface structure of the car.” (Ex. 2004 at ¶ 10). I disagree with these statements.

10. In the 1995-1997 timeframe, a subway car was normally constructed such that it had a cavity in between its interior wall and its exterior shell. Such a cavity was important to allow space for the inclusion of (a) thermal insulation, (b) sound deadening material, (c) wiring and cabling, and (d) an array of structural members which could be used for the mounting of interior equipment. Indeed, the '602 Patent itself states that “A subway car is normally constructed so that it has a cavity wall, defined between its outer structural shell and its inner lining wall, the cavity providing for wiring and cables and other mechanical functions, and, at places, containing insulation.”

(Ex. 1001 at 55:59). The last time the state of the art included rail cars that did not have a cavity in between the interior wall and exterior shell was well before 1950.

11. Namikawa bears an application date of November 29, 1990 and a publication date of July 24, 1992. (Ex. 1005 at 1). Accordingly, a person of ordinary skill in the art in the 1995-1997 timeframe would have understood Figure 1 of Namikawa to be disclosing a subway car having a cavity in between the interior wall and the exterior shell. Thus, contrary to the statements made by the Patent Owner and Mr. Long, a person of ordinary skill in the art would have understood Figure 1 of Namikawa to be disclosing a subway car having space beyond the wall, including the availability of space beyond the wall at the junction of the sidewall and the ceiling to allow for the screen of the monitor to be substantially flushed with the adjacent wall surface structure of the car.
12. The Response appears to take the position that Sasao is limited to a rear projection television. (Response at 21). I disagree with this apparent position. Sasao discloses that “an ordinary television having a CRT may serve as the image formation part.” (Ex. 1004 at 3). Indeed, Sasao is directed towards “display devices,” and more generally, Sasao states that “[t]he present invention relates to a display device such as a rear projection

television, and in particular relates to a display device that is structured so as to be housed at the interior of a wall.” (Ex. 1004 at 2). Accordingly, Sasao is not limited to only rear projection televisions.

13. The Response takes the position that Namikawa discloses that its televisions are mounted on a “wall face” and therefore not mounted at the claimed “junction.” (Response at 18-20). I disagree with this position. First, there is no basis for saying Namikawa’s screens are “externally mounted.” Namikawa’s Figure 1 does not show any mounting structure or cables. Therefore, one of ordinary skill in the art reading the disclosure of Namikawa would have understood the screens in Namikawa’s Figure 1 to be at the very least partially in the cavity between the interior surface and the external shell of the railcar. Moreover, the fact that Namikawa refers to the curved portion of its wall where the televisions are mounted as the “wall face” does not somehow mean that this curved portion of the wall is not the claimed “junction.” The conclusion that Namikawa discloses televisions mounted at the “junction” of the sidewall and ceiling is immediately apparent to one of ordinary skill in the art from looking at Figure 1 of Namikawa, reproduced below:

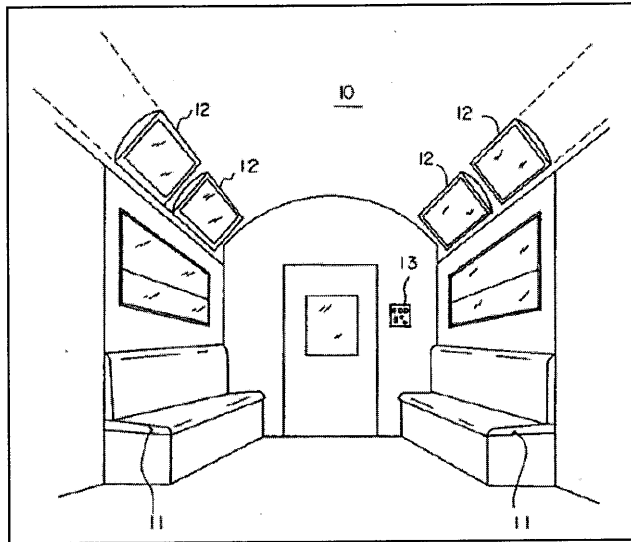

14. Indeed, Patent Owner’s own expert Mr. Long testifies that “[i]t would be clear to one of ordinary skill in the art that the ‘junction of the sidewall and the ceiling’ in a subway car is not a single point, but an area between the ceiling and a sidewall that is curved.” (Ex. 2004 at ¶ 24). Under this definition, one of ordinary skill in the art would understand Figure 1 of Namikawa to be disclosing televisions mounted at the “junction” of the sidewall and ceiling.
15. The Response states that “A person of ordinary skill in the art would not take the teachings of a monitor with a screen that is adjusted forward to accomplish a flush mount in a flat sidewall (as in Sasao) and expect to similarly mount the television at the curved junction of the sidewall and the ceiling.” (Response at 30). I disagree with this statement. As a threshold

matter, the junction of the sidewall and the ceiling does not have to be curved. For example, there are several models of New York City Transit (“NYCT”) railcars where the junction of the sidewall and the ceiling does not follow the exterior shape of the railcar, and the junction provides for a cavity to mount additional equipment. One early example is the NYCT R-38 railcars (built in 1966-67 by the St. Louis Car Company). In addition, the Response is suggesting that it would somehow be difficult for a person of ordinary skill in the art to modify the curved wall surface in Namikawa to have a flat wall surface instead. To the contrary, such a modification would have been well within the knowledge and ability of one of skill in the art in the 1995-1997 timeframe. It would not have been difficult for a person of ordinary skill in the art to interchange curved structural pieces of wall with flat structural pieces of wall in Namikawa. Specifically, in 1995-1997 many railcar manufacturers used fiberglass panels at the junction of a sidewall and ceiling because fiberglass panels are light in weight, last for a long time, require low maintenance, and are good insulators. Fiberglass panels can easily be molded into any shape and have the mechanical strength to support many components mounted thereon. In addition, fiberglass panels installed in a railcar are easy to replace because each fiberglass panel can individually be assembled or disassembled inside a railcar. Therefore, the widespread

use of fiberglass panels at the junction of a sidewall and ceiling in subway cars in 1995-1997 would have allowed a person of ordinary skill in the art great flexibility in modifying the shape of the junction to whatever suited his intended purpose, such as the modification of a curved wall surface into a flat wall surface. In that case, to flush mount a flat screen TV in the flat junction one would only have to cut out a hole and run power to the hole.

16. Systems for mounting televisions in subway cars (whether it be to the interior wall or to structural members in the cavity between the interior wall and the exterior shell) were widely available to persons of ordinary skill in the art in the 1995-1997 timeframe.

17. One of ordinary skill in the art would have known how to mount Namikawa's televisions to structural members in the cavity such that the television screens would be substantially flushed with the adjacent wall surfaces.

B. FRA Regulations

18. The Response states that "In paragraph 31 [of Ex. 1014], the Declaration mentions TVs as examples of such 'interior fittings,' without providing any citation to the FRA rule(s) where a 'fitting' is defined to include televisions or video monitors. This is a blatant cognitive leap, of course driven by hindsight in view of the disclosure in the '602 patent." (Response at 13).

However, my original declaration (Ex. 1014 at ¶ 31) cited to 62 Fed. Reg. 49728-01 (proposed Sept. 23, 1997) (to be codified at 49 C.F.R. § 238.233) (attached as Appendix A). Paragraph (d) of proposed § 238.233, Interior Fittings and Surfaces, provided that “[t]o the extent possible, all interior fittings in a passenger car, except seats, shall be recessed or flush-mounted.” (*Id.*, 49745). Under § 238.5 of the proposed rule, an interior fitting was defined as “any auxiliary component in the passenger compartment which is mounted to the floor, ceiling, sidewalls, or end walls and projects into the passenger compartment from the surface or surfaces to which it is mounted.” (*Id.*, 49793). “[S]ide and end walls, floors, door pockets, or ceiling lining materials” were excluded from this definition. (*Id.*, 49793-4). Furthermore, this definition is consistent with how someone of ordinary skill in the art would understand the term “interior fitting” as used in the industry. Accordingly, one of ordinary skill in the art would understand the term “interior fitting” as used in the FRA rules to encompass a television or display mounted inside the rail car at any location.

V. COMPENSATION

19. Although I am compensated for the time I work on this litigation, this compensation is not dependent on the outcome of this proceeding.

I hereby declare that all statements made herein of my own knowledge are true and that all statements made on information and belief are believed to be true; and further that these statements were made with the knowledge that willful false statements and the like so made are punishable by fine or imprisonment, or both, under Section 1001 of Title 18 of the United States Code.

Dated: November 6, 2017

A handwritten signature in cursive script, appearing to read "Lowell Malo", written over a horizontal line.

Lowell Malo

APPENDIX A

Selected Pages from Passenger Equip. Safety Standards, 62 Fed. Reg. 49728-01
(proposed Sept. 23, 1997) (to be codified at 49 C.F.R. § 238.233)

62 FR 49728-01, 1997 WL 582679(F.R.)
PROPOSED RULES
DEPARTMENT OF TRANSPORTATION
Federal Railroad Administration
49 CFR Parts 216, 223, 229, 231, 232, and 238
[FRA Docket No. PCSS-1, Notice No. 2]
RIN 2130-AA95

Passenger Equipment Safety Standards

Tuesday, September 23, 1997

***49728** AGENCY: Federal Railroad Administration (FRA), Department of Transportation (DOT).

ACTION: Notice of proposed rulemaking (NPRM).

SUMMARY: FRA is proposing a rule establishing comprehensive Federal safety standards for railroad passenger equipment. The proposed rule contains requirements concerning equipment design and performance criteria related to passenger and crew survivability in the event of a passenger train accident; the inspection, testing, and maintenance of passenger equipment; and the safe operation of passenger train service. The proposed rule is designed to address the safety of passenger train service in an environment where technology is advancing, and equipment is being designed for operation at higher speeds. The rule would amend existing regulations concerning special notice for repairs, safety glazing, locomotive safety, safety appliances, and railroad power brakes as applied to passenger equipment.

The proposed rule does not apply to tourist and historic railroad operations. However, after consulting with the excursion railroad associations to determine appropriate applicability in light of financial, operational, or other factors unique to such operations, FRA may prescribe requirements for these operations that are different from those affecting other types of passenger operations.

DATES: (1) Written comments: Written comments must be received on or before November 24, 1997. Comments received after that date will be considered by FRA and the Passenger Equipment Safety Standards Working Group to the extent possible without incurring substantial additional expense or delay. The docket will remain open until the Working Group proceedings are concluded. Requests for formal extension of the comment period must be made by November 7, 1997.

(2) Public hearing: FRA intends to hold a public hearing to allow interested parties the opportunity to comment on specific issues addressed in the NPRM. The date and location of the hearing will be set forth in a forthcoming notice that will be published in the Federal Register. Anyone who desires to make an oral statement at the hearing must notify the Docket Clerk by telephone (202-632-3198), and must submit three copies of the oral statement that he or she intends to make at the hearing. The notification should also provide the Docket Clerk with the participant's mailing address. FRA reserves the right to limit participation in the hearings of persons who fail to provide such notification. The date by which the Docket Clerk must be notified about the oral statement and receive copies of it will be set forth in the notice announcing the hearing.

ADDRESSES: Written comments should identify the docket number and must be submitted in triplicate to the Docket Clerk, Office of Chief Counsel, Federal Railroad Administration, 400 Seventh Street, S.W., Mail Stop 10, Washington, D.C. 20590. Persons desiring to be notified that their comments have been received by FRA should submit a stamped, self-addressed postcard with their comments. The Docket Clerk will indicate on the postcard the date on which the

that the performance of individual components of a rail passenger car in a real-world fire environment may be different from that experienced in bench-scale tests due to vehicle geometry and materials interaction.[FN2]

The NFPA publishes a standard (NFPA 130) covering fire protection requirements for fixed guideway transit systems and for life safety from fire in transit stations, trainways, vehicles, and outdoor maintenance and storage areas. (A copy of the 1995 edition of this standard has been placed in the public docket for this rulemaking.) However, this standard does not apply to passenger railroad systems including those that provide commuter service (NFPA 130 1-1.2). An APTA representative on the Working Group who is also an NFPA member has initiated an NFPA-sponsored task force to revise the scope of NFPA 130 to cover all passenger rail transportation systems, including intercity and *49745 commuter rail, and revise other provisions as necessary. (Copies of the correspondence concerning the establishment of this task force have also been placed in the public docket.) FRA and the Working Group will evaluate the results of this effort for application to this rulemaking.

Safety Glazing Standards

Existing regulations found in 49 CFR part 223 provide minimum requirements for glazing materials in order to protect railroad passengers and employees from injury as a result of objects striking the windows of locomotives, cabooses, and passenger cars. Noting some possible concerns with these requirements, FRA sought comment on whether these standards should be revised and requested information on any glazing-related injuries to passenger train occupants (61 FR 30696).

The Sierracin/Sylmar Corporation (Sierracin) commented that rail glazing meeting much higher impact and ballistic requirements is currently available, economically viable, and in fact in use by a few rail agencies (mass transit and commuter rail) here in the United States. Among its observations in particular, Sierracin noted that the strength of the glazing frame could quite easily be tested. Further, it explained that from its experience as a glazing manufacturer it is aware of very few ballistic attacks on trains, and such attacks have been limited to the side windows of locomotives or coach cars or both—not to end-facing windows. In addition, Sierracin pointed out that since the impact energy of an object is a function of velocity, an object's destructive capability increases as the speed of the surface it impacts increases.

FRA believes that existing safety glazing requirements have largely proven effective in passenger service at speeds up to 125 mph. In fact, FRA is concerned that less stringent requirements would create vulnerability to objects thrown at trains as well as the risk of ejection of passengers during train derailments. Because the safety glazing standards do not address the performance of the frame which attaches the glazing to the car body, FRA is proposing frame performance requirements for all passenger equipment. Moreover, FRA believes that more stringent glazing requirements are necessary on passenger equipment operating at speeds greater than 125 mph because of the increased destructive potential of an object impacting equipment operating at such speeds. Additionally, improved marking and periodic inspection of emergency windows are being addressed in FRA's emergency preparedness rulemaking.

Train Interior Safety Features

A review of the accident/incident data, related to fatalities and injuries on passenger trains for the period of 1972 to 1973, indicates that collapse of the equipment structure and the loss of sufficient space for the passengers to ride out the collision is the principal cause of fatality in train accidents, resulting in approximately 63 percent of the fatalities and 27 percent of the serious injuries. Fire and post-collision conditions result in 30 percent of the fatalities and 16 percent of the serious injuries. Thus, collapse of the equipment structure, fire, and post-collision conditions account for 93 percent of the fatalities and 43 percent of the serious injuries. To address these major causes of fatalities and injuries, FRA is proposing comprehensive requirements related to structural design, fire protection, and emergency exits. As discussed above, FRA believes these proposed requirements will aid in reducing the number of fatalities and injuries by minimizing the collapse of equipment, reducing the likelihood of fire, and ensuring accessible and operable emergency exits.

Prior research also indicates, however, that passengers striking interior objects in trains, principally during collisions and derailments, accounts for 57 percent of the serious injuries and 7 percent of the fatalities occurring on passenger trains. [FN3] Therefore, as an initial measure to reduce these numbers, FRA proposals include requiring that:

- Passenger seats and other interior fittings be securely attached to the car body;
- Interior fittings in a passenger car be recessed or flush-mounted;
- Overhead storage racks provide restraint for stowed articles; and
- Sharp edges be padded or otherwise avoided.

Overall, FRA's proposed requirements rely on "compartmentalization" or "passive restraints" (i.e., requiring no action to be taken on the part of the occupant) as a passenger protection strategy. The proposed requirements are based on the current available research, discussed in detail below, which indicates that during a collision the interior environment of a passenger coach is substantially less hostile than the interiors of automobiles and aircraft. In fact, current research indicates that the interior of a typical intercity passenger coach without active restraints provides a level of protection to the occupants that is at least as high as that provided to automobile and transport aircraft passengers with active restraints.

Some research indicates that there may be a potential for even a greater level of passenger protection if lap belts and shoulder harnesses are utilized on passenger trains. In fact, FRA is proposing that lap belts and shoulder harnesses be required in the cab of a Tier II train, as recommended by the Tier II Equipment Subgroup. Due to the high strength of the cab and its forward location near the expected point of impact in many different collision scenarios, decelerations experienced by crewmembers in the cab of Tier II trains may be high. Accordingly, members of the subgroup believed that restraints for the crewmembers could provide a significant benefit. FRA requests information and comment from interested parties as to whether there is any existing research or experience which would justify proposing active seat restraints in the current stage of this rulemaking. However, FRA believes more research is necessary in this area in order to determine the feasibility and effectiveness of such active restraints as well as the impact on seat design and strength. Although FRA currently proposes a passenger protection strategy based on compartmentalization, FRA will be undertaking an aggressive research and testing program to determine the feasibility and effectiveness of active restraints such as lap belts and shoulder harnesses. If this research indicates that these types of active restraints are a viable and feasible means of providing additional protection to the riding public, then FRA will propose the use of such restraints in the second NPRM on passenger equipment scheduled for development in 1998.

Discussion

The principal means of protecting occupants during accidents include "friendly" ("delethalized") interior arrangements and occupant restraints, such as lap belts, shoulder harnesses and airbags. Occupant protection devices which require some action on the part of the occupant, such as buckling a seatbelt, are termed "active devices," while protection devices which require no action, such as automobile door-mounted shoulder harnesses and airbags, are termed "passive devices." Both active and passive occupant protection strategies *49746 act to limit the decelerations and to distribute the loads imparted to occupants during an accident. Typical passenger protection strategies in automobiles include airbags, lap belts and shoulder harnesses, and friendly lower dashboard designs which limit thigh loads imparted during a collision. Typical passenger protection strategies in transport category aircraft, intended to protect passengers during accidents occurring during takeoff or landing, include seatbelts and friendly design of the seatback or bulkhead ahead of the occupant which limit the decelerations of the occupant's head.

The passenger protection devices incorporated into a vehicle must allow occupants to survive the deceleration of the volume within which they are contained. The decelerations of the occupant volume of an automobile in a collision can

Paragraph (i) proposes to require that passenger cars be equipped with a means for the emergency brake to be applied that is clearly identified and accessible to passengers. This is a longstanding industry practice and an important safety feature because crucial time may be lost requiring passengers sensing danger to find a member of the train crew to stop the train.

Paragraph (j) contains proposed provisions to ensure that the dynamic brake does not become a safety-critical device. Railroads have consistently held that dynamic brakes are not safety devices because the friction brake alone is capable of safely stopping a train if the dynamic brake is not available. The proposed provisions include requiring that the blending of the friction and dynamic brakes be automatic, that the friction brakes alone be able to stop the train in the allowable stopping distance, and that a failure of the dynamic brake does not cause thermal damage to wheels or discs due to the greater friction braking load. FRA believes that without these requirements the dynamic brake would most likely become a safety-critical item and railroads would not be permitted to dispatch trains unless the dynamic brake were fully operational.

Paragraph (k) proposes to require that either computer modeling or dynamometer tests be performed to confirm that new brake designs not result in thermal damage to wheels or discs. Further, if the operating parameters of the new braking system change significantly, a new simulation must be performed. This proposal provides a means to ensure that the requirements proposed in paragraphs (f) and (g) are being complied with by new brake designs.

Paragraph (l) proposes to require that all locomotives ordered on or after January 1, 1999, or placed in service for the first time on or after January 1, 2001, be equipped with effective air coolers or air dryers on those locomotives that are equipped with air compressors. The coolers or dryers must be capable of providing air to the main reservoir with a dew point suppression at least 10 degrees F. below ambient temperature. FRA and most members in the industry agree that moisture is a major cause of brake line contamination. Consequently, reducing moisture leads to longer component life and better brake system performance. Currently, virtually all passenger railroads purchase only locomotives equipped with air dryers or coolers. Therefore, FRA proposes to require the continuation of what it believes is good industry practice.

§238.233 Interior Fittings and Surfaces

This section contains proposed requirements concerning interior fittings and surfaces that apply, as specified in this section, to passenger cars and locomotives ordered on or after January 1, 1999, or placed in service for the first time on or after January 1, 2001. This section should be read in connection with an earlier discussion of train interior safety features in the preamble.

FRA and NTSB investigations of passenger train accidents have revealed that luggage, seats, and other interior objects breaking or coming loose is a frequent cause of injury to passengers and crewmembers. During a collision, the greatest decelerations and thus the greatest forces to cause potential failure of interior fitting attachment points are experienced in the longitudinal direction, i.e., in the direction parallel to the normal direction of train travel. Current practice is to design seats and other interior fittings to withstand the forces due to accelerations of 6g in the longitudinal direction, 3g in the vertical direction, and 3g in the lateral direction. Due to the injuries caused by broken seats and other loose fixtures, FRA believes that the current design practice is inadequate.

Accordingly, paragraph (a) proposes that each seat in a passenger car remain firmly attached to the car body when subjected to individually applied accelerations of 4g in the vertical direction and 4g in the lateral direction acting on the deadweight of the seat or seats, if a tandem unit. In addition, the attachment must resist a longitudinal inertial force of 8g acting on the mass of the seat plus the impact force of the mass of a 95th-percentile male occupant(s) being decelerated from a relative speed of 25 mph and striking the seat from behind. By resisting the force of an occupant striking the seat from behind, a potential domino effect of seats breaking away from their attachments is avoided.

Paragraph (b) proposes that overhead storage racks provide longitudinal and lateral restraint for stowed articles to minimize the potential for these objects to come loose and injure train occupants. Further, to prevent overhead storage racks from breaking away from their attachment points to the car body, these racks shall have an ultimate strength capable of resisting individually applied accelerations of 8g longitudinally, 4g vertically, and 4g laterally acting on the mass of the luggage stowed. This mass shall be specified by each railroad. Paragraph (c) requires that all other interior fittings in a passenger car be attached to the car body with sufficient strength to withstand individually applied accelerations of 8g longitudinally, 4g vertically, and 4g laterally acting on the mass of the fitting. FRA believes the proposed attachment strength requirements for seats, overhead storage racks, and other interior fittings will help reduce the number of injuries to occupants in passenger cars.

Passenger car occupants may also be injured by protruding objects, especially if the occupants fall or are thrown against such objects during a train collision or derailment. As a result, FRA is proposing in paragraph (d) that, to the extent possible, all interior fittings in a passenger car, except seats, shall be recessed or flush-mounted. Such fittings do not protrude above interior surfaces and thereby help to minimize occupant injuries.

Paragraph (e) is a general, common sense prohibition against sharp edges and corners in a locomotive cab and a passenger car. Just as FRA is concerned about protruding objects, these surfaces could also injure passenger train *49770 occupants. If sharp edges and corners cannot be avoided, they should be padded to mitigate the consequences of occupant impacts.

Paragraph (f) contains the requirements for floor-mounted cab seats provided solely for the crewmembers in locomotive cabs. FRA proposes to require the seat attachment to have an ultimate strength capable of resisting the loads due to individually applied accelerations of 8g longitudinally, 4g vertically, and 4g laterally acting on the combined mass of the seat and its occupant. This requirement is more stringent than the requirement for seats in passenger cars in paragraph (a) because the mass of the seat occupant is included in determining the load that must be resisted. Cab seats designed to this requirement will allow the use of seat belts and shoulder harnesses to restrain crewmembers in a collision. Further, when turned backwards during a collision, seats designed to this requirement can effectively restrain crewmembers.

§238.235 Emergency Window Exits

This section should be read with the earlier discussion of emergency window exits in the preamble. With the exception of paragraph (b), the requirements in this section are applicable to passenger cars on or after January 1, 1998, thereby including existing passenger cars. However, the emergency window exit size requirements in paragraph (b) are only applicable to passenger cars placed in service for the first time on or after January 1, 1998. APTA has advised FRA that not all emergency window exits on existing passenger cars meet the size requirements of paragraph (b), and FRA invites comment on this point.

This section requires that a single-level passenger car, other than a passenger car of special design, have a minimum of four emergency window exits, either in a staggered configuration or with one located at each end of each side of the car. A bi-level car shall have a minimum of four emergency window exits on each main level, configured as above, so that the car has a minimum total of eight emergency window exits. Safety may be advanced by staggering the configuration of emergency window exits so that the window exits are located diagonally across from each other on opposite sides of a car, instead of placing them directly across from each other. Commenters are invited to address this issue. In addition, concern has been raised that the seat arrangement of passenger cars may block access to and the removal of emergency window exits. Commenters are also requested to address this issue.

FRA is proposing that each passenger car of special design, such as a sleeper car, have at least one emergency window exit in each compartment. Occupants of a sleeper car may have difficulty reaching the car doors quickly in an emergency from their compartments, for example, if an emergency window exit is not provided in their individual sleeping compartments.

(2) Mitigate the consequences of accidents involving railroad passenger equipment, to the extent such accidents cannot be prevented.

(b) This part prescribes minimum Federal safety standards for railroad passenger equipment. This part does not restrict a railroad from adopting and enforcing additional or more stringent requirements not inconsistent with this part.
49 CFR § 238.3

§238.3 Application.

(a) Except as provided in paragraph (c) of this section, this part applies to all:

(1) Railroads that operate intercity or commuter passenger train service on standard gage track which is part of the general railroad system of transportation;

(2) Railroads that provide commuter or other short-haul rail passenger train service in a metropolitan or suburban area as described by 49 U.S.C. 20102(1), including public authorities operating passenger train service; and

(3) Rapid transit operations in an urban area.

(b) Railroads that permit to be used or hauled on their lines passenger equipment subject to this part, in violation of a power brake provision of this part or a safety appliance provision of this part, are subject to the power brake and safety appliance provisions of this part with respect to such operations.

(c) This part does not apply to:

(1) Rapid transit operations in an urban area that are not connected with the general railroad system of transportation;

(2) Circus trains; or

(3) Tourist, scenic, historic, or excursion operations, whether on or off the general railroad system of transportation.
49 CFR § 238.5

§238.5 Definitions.

As used in this part—

AAR means the Association of American Railroads.

Alerter means a device or system installed in the operator cab to promote continuous, active operator attentiveness by monitoring select operator-induced control activities. If fluctuation of a monitored operator control is not detected within a predetermined time, a sequence of audible and visual alarms is activated so as to progressively prompt a response by the operator. Failure by the operator to institute a change of state in a monitored control, or acknowledge the alerter alarm activity through a manual reset provision, results in a penalty brake application, bringing the locomotive or train to a stop.

Anti-climbing mechanism means a device at the ends of adjoining vehicles in a train that is designed to engage when subjected to large buff loads to prevent the override of the vehicles.

Bind means restrict the intended movement of one or more brake system components by reduced clearance, by obstruction, or by increased friction.

Block of cars means one car or multiple cars in a solid unit coupled together for the purpose of being added to, or removed from, a train as a solid unit.

Brake, air or power brake means a combination of devices operated by compressed air, arranged in a system, and controlled manually, electrically, or pneumatically, by means of which the motion of a car or locomotive is retarded or arrested.

Brake control system means the components, including software, that either automatically or under the control of the engineer control the retarding force applied to the train by the brake system.

Brake, disc means a retardation system used on some rail vehicles, primarily passenger equipment, that utilizes flat metal discs as the braking surface instead of the wheel tread.

Brake, dynamic means a train braking system whereby the kinetic energy of a moving train is used to generate electric current at the locomotive traction motors, which is then dissipated through banks of resistor grids or back into the catenary or third rail system.

Brake, effective means a brake that is capable of producing its required design retarding force on the train.

Brake indicator means a device, actuated by brake cylinder pressure, which indicates whether brakes are applied or released.

Brake, inoperative means a primary brake that, for any reason, no longer applies or releases as intended or is otherwise ineffective.

Brake, on-tread friction means a braking system that uses a brake shoe that acts on the tread of the wheel to retard the vehicle.

Brake, parking or hand brake means a brake that can be applied and released by hand to prevent movement of a stationary car or locomotive.

Brake pipe means the system of piping (including branch pipes, angle cocks, cutout cocks, dirt collectors, hose, and hose couplings) used for connecting locomotives and all cars for the passage of air to control the locomotive and car brakes.

Brake, power means "air brake" as that term is defined in this section.

Brake, primary means those components of the train brake system necessary to stop the train within the signal spacing distance without thermal damage to friction braking surfaces.

Brake, secondary means those components of the train brake system which develop supplemental brake retarding force that is not needed to stop the train within signal spacing distances or to prevent thermal damage to wheels.

Brake shoes or pads aligned with tread or disc means that the surface of the brake shoe or pad, respectively, engages the surface of the wheel tread or disc, respectively, with no more than a ¼ inch overhang.

Braking system, blended means a braking system where the primary brake and one or more secondary brakes are ***49793** automatically combined to stop the train. If the secondary brakes are unavailable, the blended brake uses the primary brake alone to stop the train.

Calendar day means a time period starting at 12:01 am and ending at midnight on a given date.

Class I brake test means a complete passenger train brake system test (as further specified in §238.313) performed by a qualified mechanical inspector to ensure that the air brake system is 100 percent effective.

Class IA brake test means a test and inspection (as further specified in §238.315) of the air brake system on each car in a passenger train to ensure the air brake system is 100 percent effective.

Class II brake test means a test (as further specified in §238.317) of brake pipe integrity and continuity from the controlling locomotive to the rear unit of a passenger train.

Collision posts means members of the end structures of a vehicle that project upward vertically from the underframe to which they are securely attached, and that provide protection of occupied compartments from an object penetrating the vehicle during a collision.

Control valves means that part of the air brake equipment on each car or locomotive that controls the charging, application, and release of the air brakes, in response to train line commands.

Corner posts means structural members located at the intersection of the front or rear surface with the side surface of a vehicle and which extend vertically from the floor support structure to the roof support structure. Corner posts may be combined with collision posts to become part of the end structure.

Crack means a fracture without complete separation into parts, except that, in a casting, a shrinkage crack or hot tear that does not significantly diminish the strength of the member is not a crack.

Crash energy management means an approach to the design of rail passenger equipment which controls the dissipation of energy during a collision to protect the occupied volumes from crushing and to limit the decelerations on passengers and crewmembers in those volumes. This may be accomplished by designing energy-absorbing structures of low strength in the unoccupied volumes of a rail vehicle or passenger train to collapse in a controlled fashion, while providing higher structural strength in the occupied volumes. Energy deflection can also be part of a crash energy management approach. Crash energy management can be used to help provide anti-climbing resistance and to reduce the risk of train buckling during a collision.

Crash refuge means a volume with extreme structural strength designed to maximize the survivability of crewmembers stationed in the locomotive cab during a collision.

Crewmember means a railroad employee called to perform service covered by 49 U.S.C. 21103 and subject to the railroad's operating rules and program of operational tests and inspections required in §§217.9 and 217.11 of this chapter.

Critical buckling stress means minimum stress necessary to initiate buckling of a structural member.

Emergency application means an irretrievable brake application resulting in the maximum retarding force available from the train brake system.

End structure means the main support structure projecting upward from the floor or underframe of a locomotive, passenger car, or other rail vehicle. The end structure is securely attached to the underframe at each end of a rail vehicle.

Foul means restrict the intended movement of one or more brake system components because the component is snagged, entangled, or twisted.

Fuel tank, integral means a fuel containment volume that is integral with some other structural element of the locomotive not designed solely as a fuel container.

Full-height collision post, corner post, or side frame post means any vertical framing member in the car body structure that spans the distance between the underframe and the roof at the car body section where the post is located. For collision posts located at the approximate third points of an end frame, the term "full-height" applies to posts that extend and connect to supporting structural members in the roof at the location of the posts, or to a beam connected to the tops of the end-frame and supported by the roof rails (or anti-telescoping plate), or to both.

Full service application means a brake application which results in a brake cylinder pressure at the service limiting valve setting or equivalent.

Glazing, end-facing means a glazing panel located where a line perpendicular to the exterior surface of the panel makes an angle of 50 degrees or less with the longitudinal center line of the rail vehicle in which the panel is installed. A glazing panel that curves so as to meet the definition for both side-facing and end-facing glazing is end-facing glazing.

Glazing, exterior means a glazing panel that is an integral part of the exterior skin of a rail vehicle with a surface exposed to the outside environment.

Glazing frame means the arrangement used to install the glazing into the structure of a rail vehicle.

Glazing, interior means a glazing panel with no surface exposed to the outside environment and which is protected from projectiles by the structure of a rail vehicle.

Glazing, side-facing means a glazing panel located where a line perpendicular to the exterior surface of the panel makes an angle of more than 50 degrees with the longitudinal center line of the rail vehicle in which the panel is installed.

Handrails means safety appliances installed on either side of a rail vehicle's exterior doors to assist passengers and crew to safely board and depart the vehicle.

Head end power means power generated on board the locomotive of a passenger train used for purposes other than propelling the train, such as cooking, heating, illumination, ventilation and air conditioning.

Hunting oscillations means, for purposes of Tier I equipment, lateral oscillations of trucks that could lead to a dangerous instability and, for purposes of Tier II equipment, truck frame lateral oscillations exceeding 0.8g peak-to-peak for six or more consecutive oscillations.

In passenger service, when used in connection with passenger equipment, means passenger equipment subject to this part that is carrying, or available to carry, fare-paying passengers.

In service, when used in connection with passenger equipment, means:

- (1) Passenger equipment subject to this part that is in passenger service; and
- (2) All other passenger equipment subject to this part, unless the passenger equipment:
 - (i) Is being handled in accordance with §§238.15, 238.17, 238.305(c)(5), or 238.503(f), as applicable;

- (ii) Is in a repair shop or on a repair track;
- (iii) Is on a storage track and is not carrying passengers; or
- (iv) Has been delivered in interchange but has not been accepted by the receiving railroad.

Interior fitting means any auxiliary component in the passenger compartment which is mounted to the floor, ceiling, sidewalls, or end walls and projects into the passenger compartment from the surface or surfaces to which it is mounted. Interior *49794 fittings do not include side and end walls, floors, door pockets, or ceiling lining materials, for example.

Lateral means the horizontal direction perpendicular to the direction of travel of a rail vehicle.

Locomotive means a piece of on-track equipment, other than hi-rail, specialized maintenance, or other similar equipment, which may consist of one or more units operated from a single control stand with one or more propelling motors designed for moving other equipment; with one or more propelling motors designed to transport freight or passenger traffic or both; or without propelling motors but with one or more control stands. This term does not include a locomotive propelled by steam power unless it is used to haul an intercity or commuter passenger train.

Locomotive cab means a compartment or space on board a locomotive where the control stand is located and which is normally occupied by the engineer when the locomotive is being operated.

Locomotive, cab car means a unit of rolling equipment intended to provide transportation for members of the general public that is without propelling motors but with one or more control stands.

Locomotive, controlling means the locomotive from which the engineer exercises control over the train.

Locomotive, MU means a unit of rolling equipment self-propelled by any power source, other than steam, and intended to provide transportation for members of the general public.

Longitudinal means in a direction parallel to the normal direction of travel of a rail vehicle.

Luminescent material means a material that absorbs light energy when ambient levels of light are high and emits this stored energy when ambient levels of light are low, making the material appear to glow in the dark.

L/V ratio means the lateral force that the flange of a vehicle's wheel exerts on the rail, divided by the vertical force that the tread of the same wheel exerts on the rail.

MIL-STD-882C means a military standard issued by the United States Department of Defense to provide uniform requirements for developing and implementing a system safety program to identify and then eliminate the hazards of a system or reduce the associated risk to an acceptable level.

Occupied volume means the spaces of a rail vehicle or passenger train where passengers or crewmembers are normally located during service operation, such as the operating cab and passenger seating and sleeping areas. Vestibules are typically not considered occupied, except when in use as a control cab.

Ordered or date ordered means the date on which notice to proceed is given by a procuring railroad to a contractor or supplier for new equipment.

49 CFR § 238.229

§238.229 Safety appliances.

All passenger equipment continues to be subject to the safety appliance requirements contained in Federal statute at 49 U.S.C. chapter 203 and in FRA regulations at part 231 and §232.2 of this chapter.

49 CFR § 238.231

§238.231 Brake system.

Except as otherwise provided in this section, on or after January 1, 1998, the following requirements apply to all passenger equipment and passenger trains.

- (a) A passenger train's primary brake system shall be capable of stopping the train with a service application from its maximum authorized operating speed within the signal spacing existing on the track over which the train is operating.
- (b) The brake system design of passenger equipment ordered on or after January 1, 1999, or placed in service for the first time on or after January 1, 2001, shall not require an inspector to place himself or herself on, under, or between components of the equipment to observe brake actuation or release.
- (c) Passenger equipment shall be provided with an emergency application feature that produces an irretrievable stop, using a brake rate consistent with prevailing adhesion, passenger safety, and brake system thermal capacity. An emergency application shall be available at any time, and shall be initiated by an unintentional parting of the train.
- (d) A passenger train brake system shall respond as intended to signals from train brake control line or lines. Control lines shall be designed so that failure or breakage of a control line will cause the brakes to apply or will result in a default to control lines that meet this requirement.
- (e) Introduction of alcohol or other chemicals into the air brake system of passenger equipment is prohibited.
- (f) The operating railroad shall require that the design and operation of the brake system results in wheels that are free of condemnable cracks.
- (g) Disc brakes shall be designed and operated to produce a surface temperature no greater than the safe operating temperature recommended by the disc manufacturer and verified by testing or previous service.
- (h) Except for a locomotive that is ordered before January 1, 1999, and placed in service for the first time before January 1, 2001, and except for a private car, all passenger equipment shall be equipped with a hand or parking brake that shall be:
- (1) Capable of application or activation by hand;
 - (2) Capable of release by hand; and
 - (3) Capable of holding the loaded unit on the maximum grade anticipated by the operating railroad.
- (i) Passenger cars shall be equipped with a means to apply the emergency brake that is accessible to passengers and located in the vestibule or passenger compartment. The emergency brake shall be clearly identified and marked.
- (j) Locomotives equipped with blended brakes shall be designed so that:
- (1) The blending of friction and dynamic brake to obtain the correct retarding force is automatic;

- (2) Loss of power or failure of the dynamic brake does not result in exceeding the allowable stop distance;
- (3) The friction brake alone is adequate to safely stop the train under all operating conditions; and
- (4) Operation of the friction brake alone does not result in thermal damage to wheels or disc rotor surface temperatures exceeding the manufacturer's recommendation.
- (k) For new designs of braking systems, the design process shall include computer modeling or dynamometer simulation of train braking that shows compliance with paragraphs (f) and (g) of this section over the range of equipment operating speeds. Changes in operating parameters shall require a new simulation prior to implementing the changes.
- (l) Locomotives ordered on or after January 1, 1999, or placed in service for the first time on or after January 1, 2001, shall be equipped with effective air coolers or dryers that provide air to the main reservoir with a dew point at least 10 degrees F. below ambient temperature.
49 CFR § 238.233

§238.233 Interior fittings and surfaces.

- (a) Each seat in a passenger car shall be securely fastened to the car body so as to withstand an individually applied acceleration of 4g acting in the vertical and in the lateral direction on the deadweight of the seat or seats, if a tandem unit. A seat attachment shall have an ultimate strength capable of resisting the longitudinal inertial force of 8g acting on the mass of the seat plus the impact force of the mass of a 95th-percentile male occupant(s) being decelerated from a relative speed of 25 mph and striking the seat from behind.
- (b) Overhead storage racks in a passenger car shall provide longitudinal and lateral restraint for stowed articles. Overhead storage racks shall be attached to the car body with sufficient strength to resist loads due to the following individually applied accelerations acting on the mass of the luggage stowed as determined by the railroad:
- (1) Longitudinal: 8g;
- (2) Vertical: 4g; and
- (3) Lateral: 4g.
- (c) Other interior fittings within a passenger car shall be attached to the car body with sufficient strength to withstand the following individually applied accelerations acting on the mass of the fitting:
- (1) Longitudinal: 8g;
- (2) Vertical: 4g; and
- (3) Lateral: 4g.
- (d) To the extent possible, all interior fittings in a passenger car, except seats, shall be recessed or flush-mounted.
- (e) Sharp edges and corners in a locomotive cab and a passenger car shall be either avoided or padded to mitigate the consequences of an impact with such surfaces.
- (f) Each floor-mounted seat provided exclusively for a crewmember assigned to occupy the cab of a locomotive shall be secured to the car body with an attachment having an ultimate strength capable of withstanding the loads due to the

following individually applied accelerations acting on the mass of the seat and the crewmember (ranging from a 5th-percentile female to a 95th-percentile male) occupying it:

(1) Longitudinal: 8g;

(2) Lateral: 4g; and

(3) Vertical: 4g.

49 CFR § 238.235

§238.235 Emergency window exits.

Except as provided in paragraph (b), the following requirements apply to all passenger cars on or after January 1, 1998—

(a) Except as provided in paragraphs (d) and (e) of this section, each passenger car shall have a minimum of four emergency window exits, either in a staggered configuration or with one located at each end of each side of the car.

(b) Each emergency window exit in a passenger car placed in service for the first time on or after January 1, 1998, shall have a minimum unobstructed opening with dimensions of 24 inches horizontally by 18 inches vertically.

(c) Each emergency window exit shall be easily operable by a 5th-percentile female without requiring the use of a tool or other implement. *49807

(d) If the car is bi-level, each main level shall have a minimum of four emergency window exits, either in a staggered configuration or with one located at each end of each side of the car.

(e) Each passenger car of special design, such as a sleeping car, shall have at least one emergency window exit in each compartment.

(f) Marking and instructions. [Reserved]

49 CFR § 238.237

§238.237 Doors.

(a) Within 2 years of the effective date of the final rule, each powered, exterior side door in a vestibule that is partitioned from the passenger compartment of a passenger car shall be equipped with a manual override that is:

(1) Capable of opening the door without power from inside the car;

(2) Located adjacent to the door which it controls; and

(3) Designed and maintained so that a person may access the override device from inside the car without requiring the use of a tool or other implement.

(b) Each passenger car ordered on or after January 1, 1999, or placed in service for the first time on or after January 1, 2001, shall have a minimum of four side doors, or the functional equivalent of four side doors, each permitting at least one 95th-percentile male to pass through at a single time.[FN1] Each powered, exterior side door shall be equipped with a manual override that is:

(1) Capable of opening the door without power from both inside and outside the car;

(2) Located adjacent to the door which it controls; and

Kokai Unexamined Utility Model Application 4-85379

(19) Japanese Patent Office (JP)
(12) Kokai Unexamined Utility Model Application (U)
(11) Laid Open Patent Application No. 4-85379
(43) Publication Date July 24, 1992
Number of Claims 4
Number of Pages
Examination Request not yet made

(51)	Int. Cl. ⁵	Identification Code	Internal File No.
	G 09 F 21/04	L	6447-5G
	B 61 D 37/00	G	7140-3D
	G 09 G 5/00	A	8121-5G

(54) Title of the Device: Public transport vehicle
(21) Application No.: 2-128348
(22) Application Date: November 29, 1990
(72) Creator: NAMIKAWA, Midori
4-5-26-1-208, Kamiosaki,
Shinagawa-ku, Tokyo-to
(71) Applicant: Sundex Inc.
1-33-2 Koyamadai, Shinagawa-ku,
Tokyo-to
(74) Agent: Patent Attorney, SAEKI, Tadao

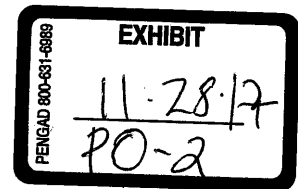

Specification

1. Title of the Device Public transport vehicle

2. Utility Model Claims

(1) A public transport vehicle characterized in that commercials or broadcast programming taken from broadcasting media can be broadcast by disposing a plurality of televisions on a wall face inside a car of a transit bus, electric train, or the like.

(2) The public transport vehicle described in claim (1) characterized in that the plurality of televisions on the wall face above seats in a car are arranged along the direction of travel.

(3) The public transport vehicle described in claim (1) characterized in that broadcast content for the televisions in each car is made to be different.

(4) The public transport vehicle described in claim (1) or (2) characterized in that the televisions are formed into a flat panel shape.

3. Detailed Description of the Device

Field of Industrial Application

The present device relates to a public transport

JP-04-085379-U (3)

vehicle such as a transit bus or electric train wherein commercials or programming can be broadcast by disposing a plurality of liquid crystal televisions above seats in the car, for example.

Prior Art and Problems to Be Solved

Conventionally, many advertisements are displayed in the cars of electric trains such as those of JR and subways; however, the medium for these advertisements is printed material resulting from printing or photographing or the like, on paper, and the advertising medium is a static form that is completely fixed. Likewise, many advertisements are displayed in transit buses traveling on city routes but, as is well known, these are all advertising media displayed on paper and can only display advertisements in a static form that is completely fixed. Moreover, conventional transit buses that travel routes or electric train cars do not have any equipment to broadcast television broadcasts, and thus there are matters that should be improved in terms of the service given to passengers of transit buses or electric trains traveling intermediate distance routes.

The present device focuses on the aforementioned matters, and an object thereof is to provide a public transport vehicle such as

JP-04-085379-U (4)

a transit bus or electric train that can broadcast, in the car, commercials and broadcast programming that are taken from broadcasting media.

Means for Solving the Problems

In order to achieve the object described above, the present device allows broadcasting of commercials or broadcast programming taken from broadcasting media by disposing a plurality of televisions on a wall face inside a car of a transit bus, electric train or the like. The plurality of televisions are disposed above the seats in the car. These televisions are formed into a flat panel shape according to one configuration of the present device.

In the aforementioned configuration, one characteristic of the present application is that the broadcast content for the televisions in each car can be different.

Operation

When commercials that are taken from broadcasting media are broadcast to televisions, passengers in a car can see dynamic advertisements in the car rather than conventional static advertisements and dynamic advertisements that have story variations can be displayed in the car. Moreover, when broadcast programming is broadcast on a liquid crystal television, the passengers in the car can view the broadcast programming being shown on the television. Therefore, while commuting to work, school, or the like,

JP-04-085379-U (5)

passengers can watch dynamic advertisements shown on the televisions or learn about the news by watching broadcast programming or watch dramas as one type of recreation, and the passengers can commute to work, school, or the like in a more relaxed manner. Moreover, because the advertisements are dynamic and these can have story variations, the effectiveness of advertising can be further improved over static advertisement on conventional paper.

Note that when the vehicle is an electric train, broadcast programming with different content can be viewed in each car by making the broadcast programming broadcast on the television different for each car. Moreover, for transit buses, the broadcast content can be made easier to view by disposing a liquid crystal television for each seat.

Furthermore, space in the car is not lost when the television is formed into a flat panel shape.

Embodiment

Hereafter, an embodiment of the present device is described with reference to the drawings.

JP-04-085379-U (6)

FIG. 1 shows one example of applying the present device to a car in an electric train of JR, a subway, or the like, and a plurality of liquid crystal televisions 12 are disposed along the direction of travel on a wall face above each seat 11 inside a car 10. The liquid crystal television is assembled in a mounting position for an advertising media using conventional paper. The liquid crystal television 12 is formed into a flat panel shape for this embodiment. Therefore, no space inside the car is lost. Each liquid crystal television 12 broadcasts content taken from broadcasting media, such as cable television for example, in other words, programming such as various types of commercials, dramas, and news. In this case, a passenger sitting in one facing seat can watch the liquid crystal television 12 above another seat and a passenger in the other seat can watch the liquid crystal television 12 above the seat of the one facing seat.

An operation panel 13 is disposed in a prescribed location in the car. The operation panel 13 turns the broadcast to the liquid crystal panels 12 on and off and switches the broadcast content. Note that a configuration is possible in which a

JP-04-085379-U (7)

conductor centrally controls turning the broadcast on and off and switching the broadcast content in each car from one location in one of the plurality of cars.

When broadcasting to the liquid crystal televisions 12 in the car, commercials can be broadcast on the liquid crystal televisions 12 on one seat side and a drama, news, or other programming can be broadcast by the liquid crystal televisions 12 on another seat side, and all liquid crystal televisions 12 in the car can broadcast commercials or programming such as news or dramas. When broadcasting commercials, the same content can be broadcast by all liquid crystal televisions 12 in the car, and a different commercial can also be broadcast on each liquid crystal television 12.

According to the above configuration, passengers in the car can enjoy dynamic commercials and other programming such as news and dramas shown on the liquid crystal television 12 that they are facing, or can obtain necessary information therefrom while sitting in a seat or holding onto a strap while riding during the commute to work, school, or the like.

JP-04-085379-U (8)

FIG. 2 shows another embodiment of the present device and shows applying the present device to a transit bus traveling in a city.

A liquid crystal televisions 22 are disposed on a wall face above the window side of seats 21 in a car 20 of a transit bus. An operation panel 23 is disposed near each seat 21. The liquid crystal television 22 above each seat 21 can be turned on and off, or the broadcast content, that is commercials or other programming such as news or dramas, can be switched by way of passengers in the seats operating the operation panel 23.

The liquid crystal televisions 22 for each of the seats 21 broadcast the broadcast content taken from broadcasting media such as cable television, as described above. When the broadcast content is a commercial, the advertisement is dynamic with story variations, and when this is a news program, necessary information can be obtained during the ride. Furthermore, in the case of broadcasts such as dramas and movies, the liquid crystal television can be watched as recreation during the ride.

JP-04-085379-U (9)

When the vehicle is a transit bus or electric train that travels intermediate distances for work and school commuting routes, the passengers must ride for a comparatively long time. In such cases, when programming such as a drama or a movie is broadcast by the liquid crystal television in the car, the passengers can enjoy themselves in a relaxed state by watching the broadcast programming as a form of recreation during the ride.

Note that in the above embodiment, the liquid crystal television 12 is used as a broadcasting medium for broadcast programming and advertisements, but other formats of television may be used, and other flat panel model televisions may also be used.

Effect of the Device

As described above, the following effects are provided by way of the present device.

(1) While riding, passengers can watch and enjoy, as a form of recreation, programming such as news, dramas, or movies that are broadcast from a liquid crystal television in the car and can ride in a relaxed state. In addition, commercials and programming broadcast from the liquid crystal televisions can take on various

JP-04-085379-U (10)

aspects and a broadcast format that is rich in variety can be adopted. Therefore, the service given to the passengers can be improved.

(2) Because dynamic advertisements with story variations can be broadcast in the car, the effectiveness of advertising can be further improved over static advertisement that is on conventional paper.

(3) A unique vehicle that provides advertising media not conventionally seen and recreation equipment can be provided.

4. Brief Description of the Drawings

FIG. 1 is a perspective view showing one embodiment of the present device, and FIG. 2 is a perspective view showing another embodiment of the present device.

- 10, 20 vehicle
- 11, 21 seat
- 12 liquid crystal television
- 13, 23 operation panel

Utility Model Applicant: Sundex Inc.
Agent: Patent Attorney, SAEKI, Tadao

FIG. 1

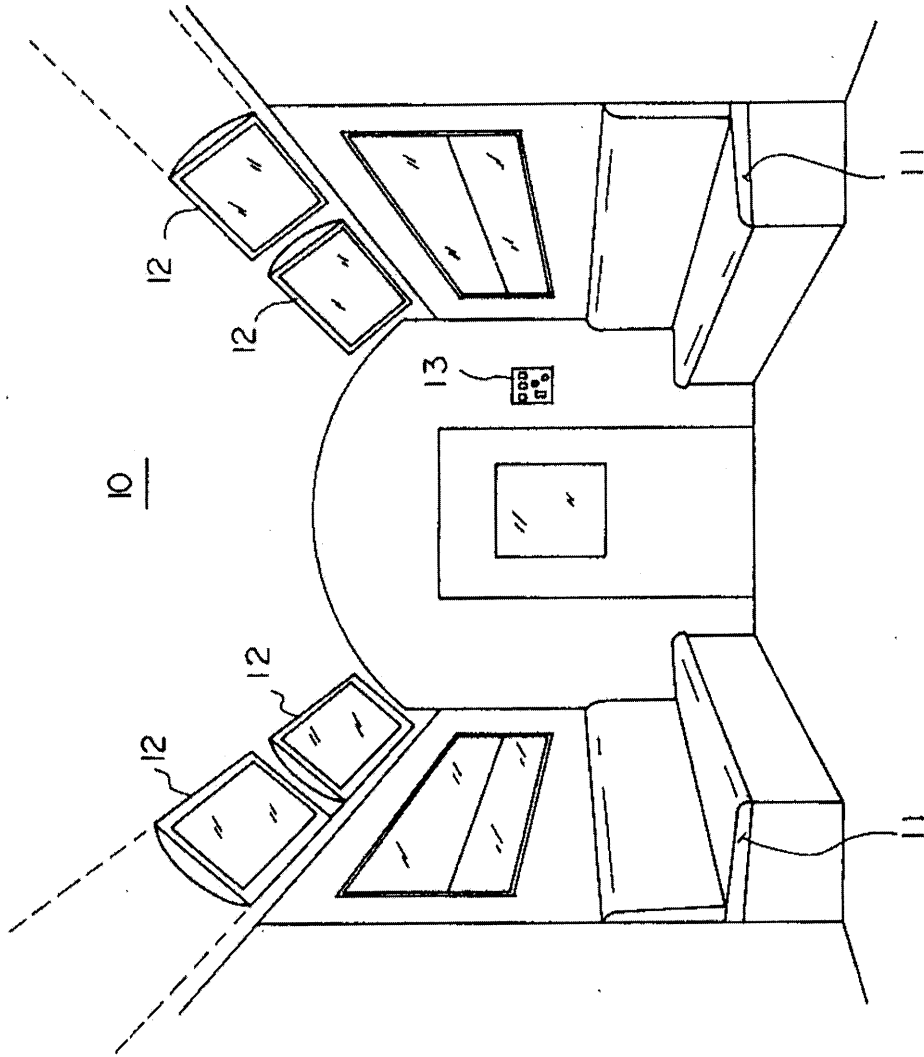

1133

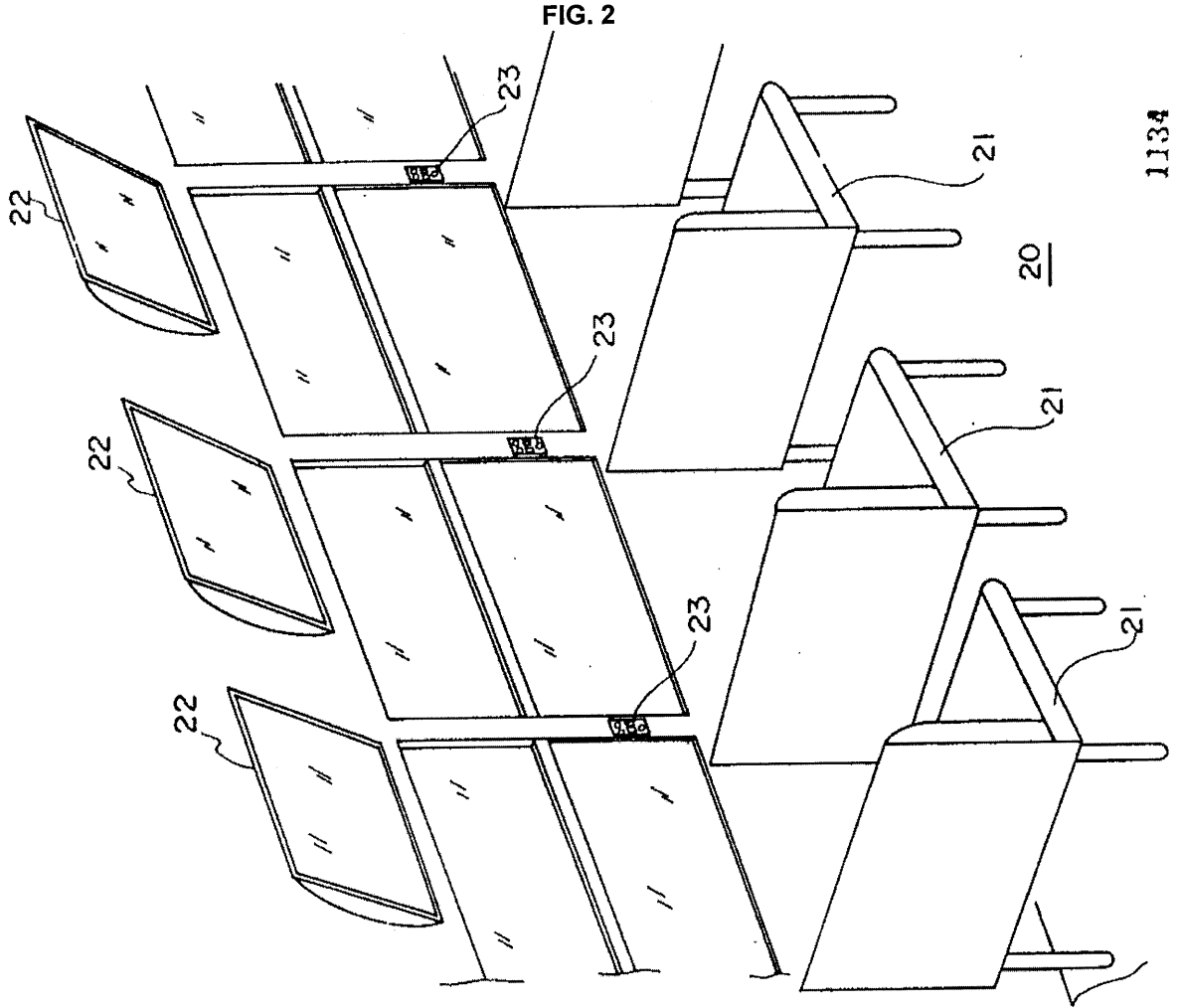

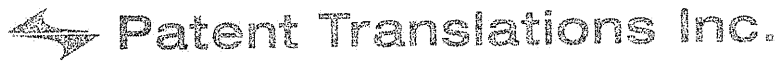

1700 Seventh Avenue, Suite 2100 mail@PatentTranslations.com
Seattle, WA 98101, USA http://www.PatentTranslations.com
Fax: 206-299-3692 Tel: 206-357-8508

Certification of Translation

Translator's Declaration: June 20, 2016

I, Carl McBee, hereby declare:

That I possess advanced knowledge of the Japanese and English languages. My qualifications are as follows:

- More than eighteen years as a Japanese technical translator
- Master of Science in Engineering (Technical Japanese Program) from University of Washington
- Formerly the Senior Bilingual Technical Writer at Nintendo of America
- US Department of Defense certification of General Professional Proficiency in Japanese

The attached translation is, to the best of my knowledge and belief, a true and accurate translation from Japanese to English of Japanese Unexamined Utility Model Application Number JP-04-85379-U. I understand that willful false statements and the like are punishable by fine or imprisonment, or both (18 U.S.C. 1001), and may jeopardize the validity of the application or any patent issuing thereon. I declare under penalty of perjury that all statements made herein of my own knowledge are true, and all statements made on information and belief are believed to be true.

Carl McBee

A handwritten signature in black ink, appearing to read 'Carl McBee', is written over a horizontal line.

(19) Japanese Patent Office (JP)

(11) Laid Open Patent
 Application No.
 2-223985

(12) Kokai Unexamined Patent Application Bulletin (A)

(51) Int. Cl.⁵

Identification Code

Internal File No.

(43) Publication Date

G 09 G 3/00
 G 09 F 9/00

363

Z

6376-5C
 6422-5C

September 6, 1990

Examination
 Request

not yet
 made

Number of
 Claims

1

Number of Page 8

(54) Title of the Invention:

System for providing nonstandard information to large indefinite number of people in transportation equipment

(21) Application No.:

1-42966

(22) Application Date:

February 27, 1989

(72) Inventor:

AMANO, Yoshikazu

Hitachi Ltd. Yokohama Factory, 292 Yoshida-cho, Totsuka-ku, Yokohama-shi, Kangawa-ken

(72) Inventor:

UMEZAWA, Kouichi

Hitachi Ltd. Design Laboratory, 1-280 Higashikoigakubo, Kokubunji-shi, Tokyo-to

(72) Inventor:

YAMAGUCHI, Tadahiro

Hitachi Ltd. Design Laboratory, 1-280 Higashikoigakubo, Kokubunji-shi, Tokyo-to

(72) Inventor:

FUKUDA, Nobuo

Hitachi Ltd. Design Laboratory, 1-280 Higashikoigakubo, Kokubunji-shi, Tokyo-to

(71) Applicant:

Hitachi Ltd.

4-6 Kanda surugadai, Chiyoda-ku, Tokyo-to

(74) Agent:

Patent Attorney OGAWA, Katsuo and one other person

Continued on the last page

SPECIFICATION

1. Title of the Invention

System for providing nonstandard information to large indefinite number of people in transportation equipment

2. Patent Claims

1. A system for providing nonstandard information to a large indefinite number of people in transportation equipment, characterized by comprising: a display device for providing nonstandard information wherein the display content can change at any time, to a large indefinite number of people in transportation equipment that provides a limited space as a transportation means; a means for transmitting the provided information to this display device from inside the transportation equipment; and a means for receiving transmitted information from outside the transportation equipment and providing the same to said transmission means in the transportation equipment.

3. Detailed Description of the Invention

(Field of Industrial Application)

The present invention relates to the opportunity of making use of time in transportation equipment, by installing a display device, which provides nonstandard information to a large indefinite number of people who are using a limited space such as an airplane, train, or bus as a transportation means, and to a system that provides various information.

(Prior Art)

Conventionally, in transportation means used by a large indefinite number of people, such as a train or a bus, information such as advertisements and notifications normally hang down as printed material, or are posted on the walls in the equipment. These are normally displayed for a limited time period, and in the case of advertisements, the provider of the transportation means obtains income from advertising contracts over a fixed period.

Note that a related known example of this sort is the "New Video Service System in Vehicles with Liquid Crystal Displays," which appeared in *Dempa Shinbun* on February 14, 1989.

(Problems to Be Solved by the Invention)

When the prior art described above is viewed from the perspective of providing information, because printed material is posted as described above, the provided information is displayed for a fixed time period, and in order to change the posted information, the printed material posted in the equipment must be replaced on each occasion. Furthermore, this posted information is commonly posted in many places, on the order of several locations to dozens of locations in a unit of equipment, but when used in dozens of connected cars, such as in a train,

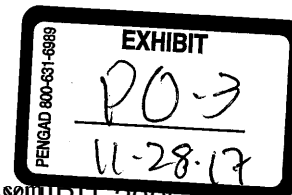

that number reaches several hundred locations. Consequently, in situations such as when postings are periodically changed, there are problems in so much as management is difficult and it is not possible to increase the utilization rate of the locations at which information is provided.

Meanwhile, when viewed from the perspective of receiving information, there are disadvantages in so much as, because the information provided is the same for a fixed time period, once new information has been seen, it will subsequently cease to garner attention, and even if new information is posted, because, for the most part, the posted information is viewed by [people] who are in its presence for on the order of a few tens of minutes, the amount of information [provided] is low, considering the [duration] of the presence of [people] at the location of the posting. Information provision means using light-emitting diodes exist, but are limited to providing standard information, wherein the information is fixed, such as the name of the station stop or the type of transportation vehicle. Furthermore, there are examples of video and text information being provided in vehicles, but this is limited to providing information that has been set up in the vehicles, and timely information is not provided.

An object of the present invention is to provide a system which solves the problems described above.

(Means for Solving the Problems)

For the problems described above, this is achieved by installing: a display device for providing nonstandard information wherein the display content can change at any time, to a large indefinite number of people in transportation equipment that provides limited space as a transportation means, such as an airplane, train, or bus; and means for transmitting the provided information to the display device from inside and outside the transportation equipment.

(Operation)

This is can be achieved by displaying the information to be provided, which had been transmitted from a transmission device, on a plurality of display devices set up at locations used by the passengers, from a device having a function for setting and transmitting the indefinite information to be provided and a function for receiving and transmitting information transmitted from outside the transportation equipment, which is provided in a location in the transportation equipment that is not used by the passengers, for example, the cockpit in an airplane, the conductor's cab in a train, or the driver's seat on a bus.

(Embodiments)

Embodiments of the present invention are described with reference to the following figures.

FIG. 1 represents the overall system of the present invention. [Reference number] 1 is transportation equipment; 2 is an antenna installed on the transportation equipment; 3 is an antenna primarily for transmitting the provided information; 4 is a device for receiving transmissions of region-specific information and signals from the transportation equipment; 5 is a

region-specific information controller, which controls the transmission of region-specific information and manages the signals received from the transportation equipment; and 6 is an information signal transmission path between the region-specific information controller and the region-specific transmitter.

FIG. 1 is described, taking an example where the transportation equipment is a bus. A region-specific information transmitter/receiver 4 is installed at each bus stop, which stores the provided information transmitted from the region-specific information controller 5, and transmits the provided information through the antenna 3 to the transportation equipment 1. The transportation equipment 1 receives the information provided through the antenna 2, and provides the information to passengers via the display information signal transmitter and the information signal display devices provided in the bus. Transportation equipment 1a provides information stored in region-specific information transmitter 4b, through antennas 3b and 2a, to the interior of the vehicle; and transportation equipment 1b provides information stored in region-specific information transmitter 4n, through antennas 3n and 2b, to the interior of the vehicle. The region-specific information controller 5 controls which information is transmitted to the region-specific information transmitter 4. Accordingly, the information transmission content from region-specific information transmitters 4a to 4n may differ from each other or be identical. In addition, the transmitted information can be changed every certain number of regions.

This system is bidirectional; when the transportation equipment 1 arrives at a stop, the provided information is received from the region-specific information transmitter/receiver described above, together with which a signal making it known that the transportation equipment 1 has arrived at the stop is transmitted to antenna 3 from antenna 2. That signal is received by the region-specific information transmitter/receiver 4, and transmitted to the region-specific information controller 5 via the transmission path 6, such that the navigation status of the transportation equipment 1 can be determined, together with which this status can be transmitted as information to the next stop to notify waiting passengers.

In this drawing, the transmission paths 6 are indicated by wires to facilitate the representation, but wireless transmission paths based on communication satellites can, of course, also be used. This scenario can be realized by installing antennas for transmission and reception, such as parabolic antennas, for the region-specific information controller 5 and the region-specific information transmitter/receiver 4.

FIG. 2 shows a display information signal transmitter and an information signal display device installed in the transportation equipment. [Reference number] 7 is a

display information signal transmitter, which comprises: a video information playback function 7b, which primarily plays back motion pictures stored on a video disk or a videotape; a text and image information input function 7e, which primarily reads out text and image information from a storage medium such as a magnetic disk or a memory card, and performs information input by way of associated input keys; a text and image information control function 7d, which performs control so as to allow the input information to be displayed; a video, text and image information combining function 7c, which combines and/or selects the motion picture information played back by the video information playback function 7b and information from the text and image information control function 7d; a region-specific information reception function 7f, which primarily receives and stores region-specific information from outside the transportation equipment; an information transmission function 7g, which finally transmits the information provided to the passengers to the information display devices; and an operation control function 7a, which operates these functions. [Reference numbers] 2 and 3 are antennas; 4 is a region-specific information transmission function, which primarily transmits region-specific information; 8 is an information display device for displaying the provided information transmitted from the display information display device [sic] 7; and 9 is a transmission path between these devices. [Reference number] 10 is an input signal, which represents travel information concerning the travelling state or the stopped state of the transportation equipment.

Normally the provided information is such that or text and image information or motion pictures stored on a video disk or a videotape are provided individually or in combination, but when the region-specific information is transmitted through the antenna 3 by way of the region-specific information transmission function 4, this is received by the antenna 2 and the transmitted data is stored by the region-specific information input function 7f and displayed on the information signal display device 8, via the text and image information control function 7d, the text and image information combining function 7c and the information transmission function 7g. This provided information can provide timely information, which is not covered by the motion picture information and text and image information that has been provided in the transportation equipment in advance. For example, emergency news can be released and information limited to things happening in that region can be provided. If region-specific information transmission functions 4 are installed along the travel route of the transportation equipment, this information can be such that the content of the provided information is changed in corresponding interval units.

FIG. 3 shows a configuration assuming that the transportation equipment is a train. This is an example in which the information signal display device 8 is provided with cultural information 11 in a section 1, with event information 12 in a section 2, and with amusement

park information 13 in a section 3. In this example, information is provided over the entire screen of the information signal display device 8, but the motion picture information or text and image information described above can be provided in combination, or a portion [of the screen] can be used to provide these.

FIGS. 4 to 7 are examples in which the information signal display devices 8, for the interior of the transportation equipment, are installed in a train.

(Effects of the Invention)

According to the present invention, locations providing information in a transportation equipment can be put to good use, while in comparison with cases in which printed materials are posted, as was conventional, not only is the management time reduced, but there is an effect of strengthening the power of the information provided to passengers because timeliness and freshness are brought out.

4. Brief Description of the Drawings

FIG. 1 is a view representing an example of the overall system of the present invention; FIG. 2 is a schematic view of an example of the device functions in the transportation equipment; FIG. 3 shows an example of the provision of region-specific information; FIG. 4, FIG. 5, FIG. 6, and FIG. 7 are views showing examples of the information signal display devices installed in the transportation equipment.

Explanation of the Reference Numbers

1... transportation equipment; 2... antenna installed in the transportation equipment; 3... antenna installed in a region-specific information transmission function; 4... region-specific information transmission function; 5... region-specific information controller; 6...transmission path; 7...display information signal transmitter; 8 ...information signal display device; 9...transmission path; 10... traveling state information input; 11, 12, 13 ... examples of region-specific information provision; 14... example of information provided by way of printed material

Agent Patent Attorney: OGAWA, Katsuo

Clean copies of the drawings (no changes to the content)

FIG. 1

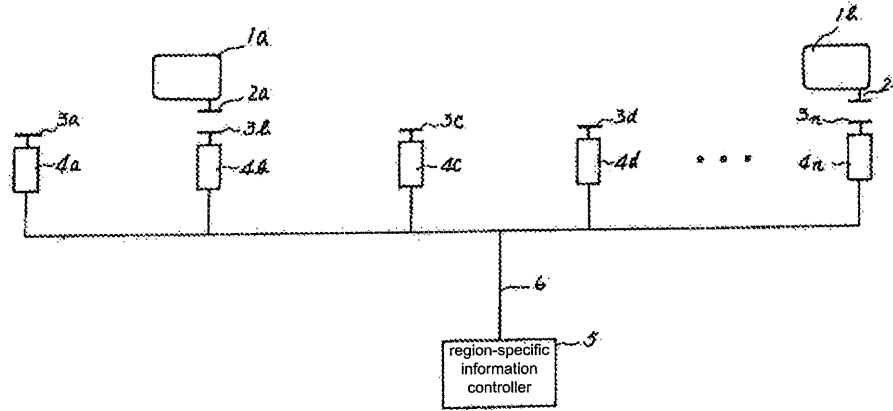

FIG. 2

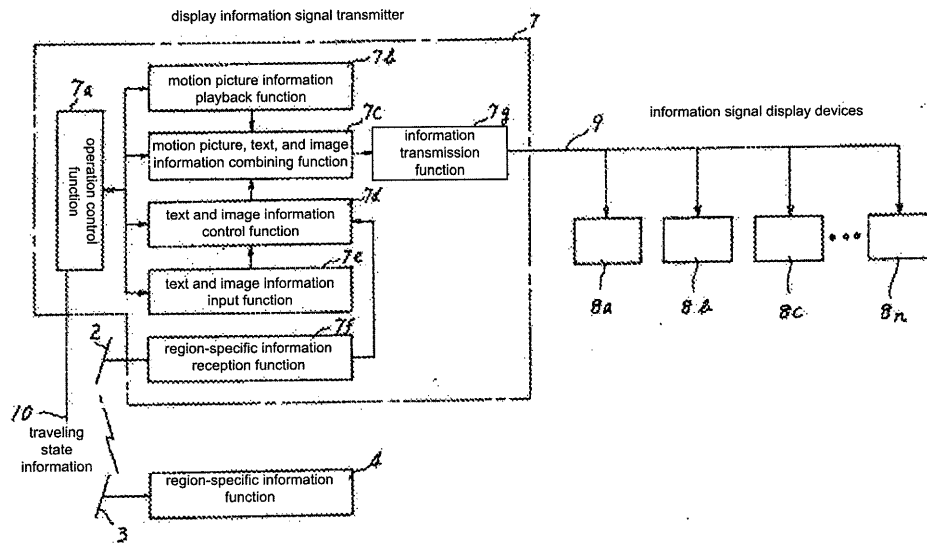

FIG. 3

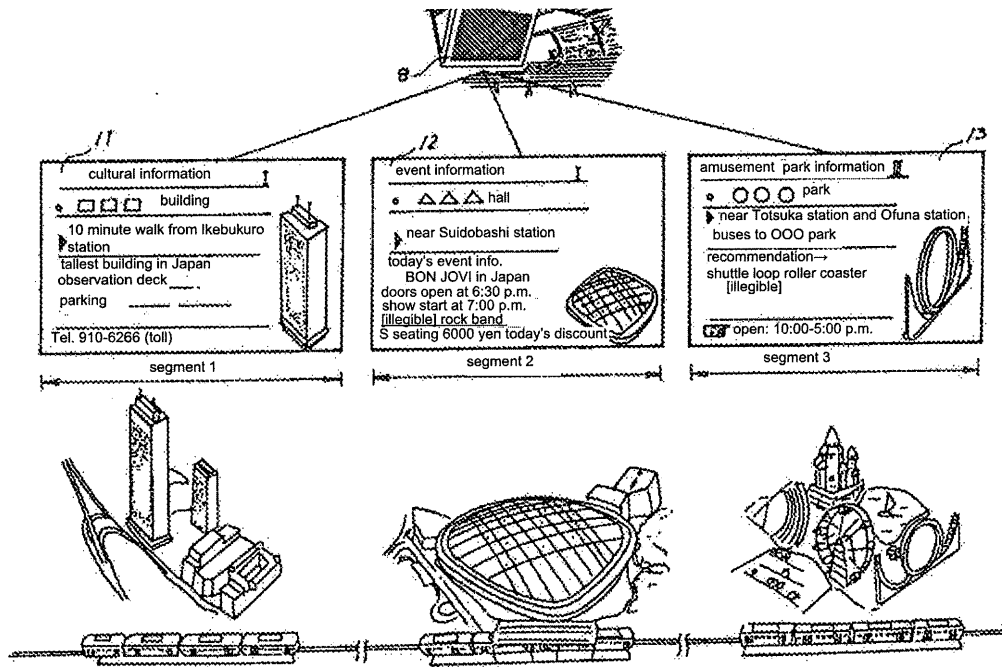

FIG. 4

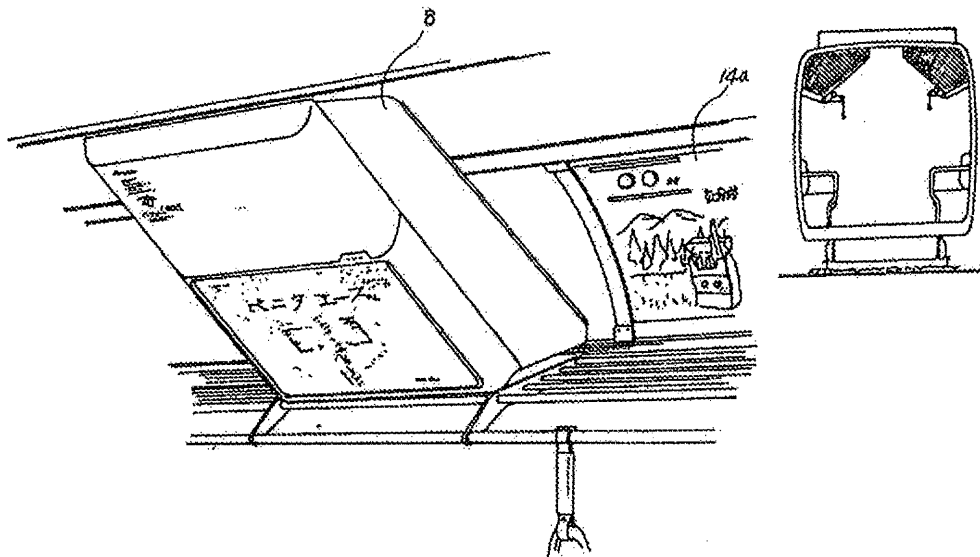

FIG. 5

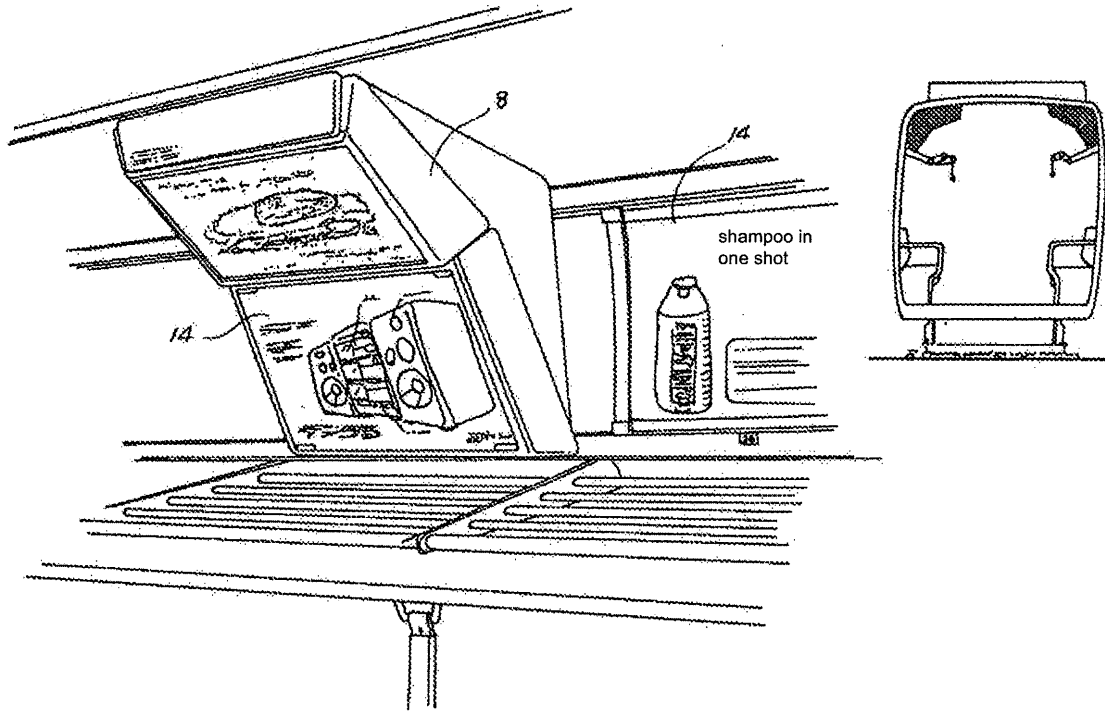

FIG. 6

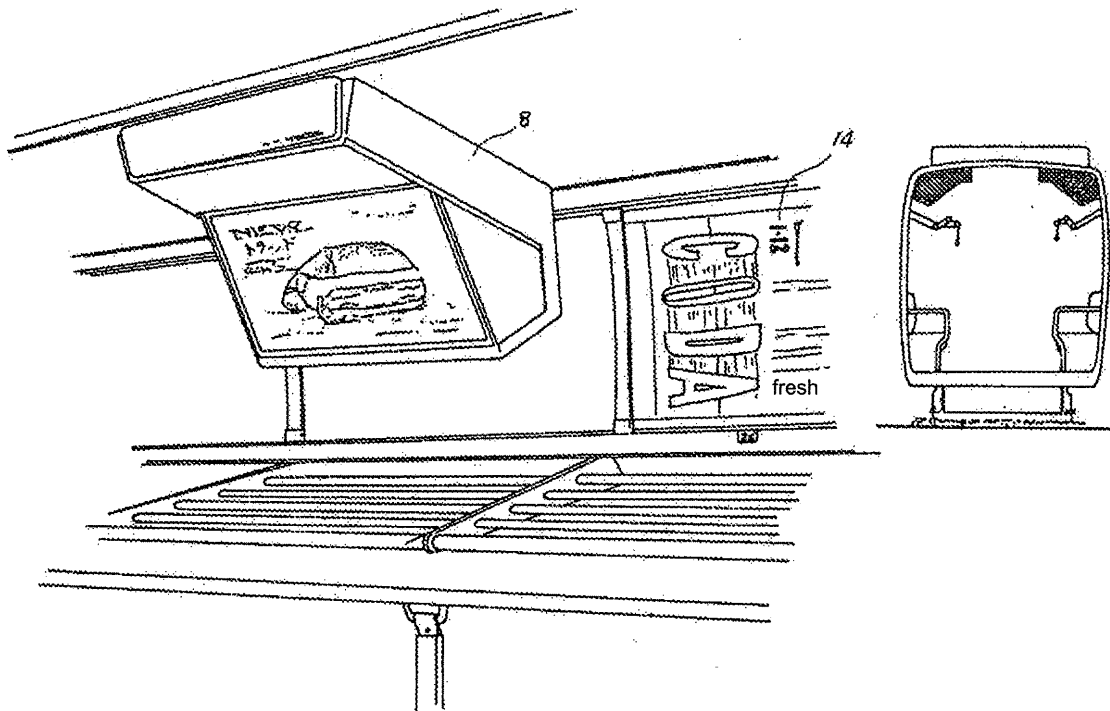
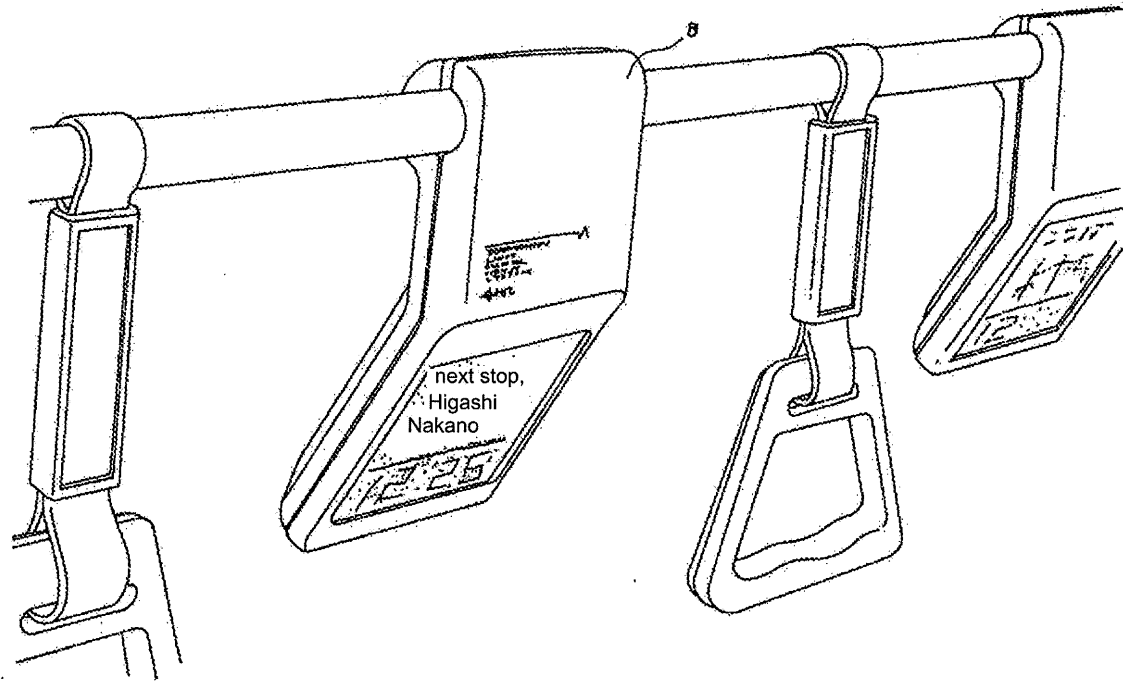

FIG. 7



Continued from the front page

(72) **Inventor:**

KAWAKATSU, Yoshihiro

Hitachi Ltd. Design Laboratory, 1-280 Higashikoigakubo,
Kokubunji-shi, Tokyo-to

Amendment to Proceedings (Formal)

June 21, 1989

To: Commissioner of the Patent Office

Case Indication

1989 Patent Application No. 42966

Title of the Invention:

System for providing nonstandard information to
large indefinite number of people in transportation
equipment

Amending Party

Relationship to the Case: Patent applicant

Name: Hitachi Ltd. (510)

Applicant:

Address Hitachi Ltd.

1-5-1, Marunouchi, Chiyoda-ku, Tokyo

Name Katsuo Ogawa, Patent Attorney (6850)

[stamp]

[illegible]

Date of Amendment Order: May 30, 1989 (transmittal
date)

Object of Amendment

All of the drawings

Amended Content

Clean copies on separate sheets of all of the
drawings initially appended to the application
(Content not changed)

[stamp] JPO, 6/21/1989, Second Application Dept.

End

Formal Examination



Certification of Translation

Translator's Declaration: September 8, 2016

I, Martin Cross, hereby declare:

That I possess advanced knowledge of the Japanese and English languages. My qualifications are as follows:

- over 25 years as a Japanese-English translator focusing primarily on patents, and technical and scientific documents;
- co-author of the *Japanese Patent Translator's Handbook*, published by American Translators Association;
- United States district court recognition as an expert in Japanese technical translation for patent litigation; and
- work experience including design and testing of electronic circuits for Research and Development Laboratories Waterloo Ltd.

The attached translation is, to the best of my knowledge and belief, a true and accurate translation from Japanese to English of Japanese Unexamined Patent Application Publication Number JP-02-223985-A. I understand that willful false statements and the like are punishable by fine or imprisonment, or both (18 U.S.C. 1001), and may jeopardize the validity of the application or any patent issuing thereon. I declare under penalty of perjury that all statements made herein of my own knowledge are true, and all statements made on information and belief are believed to be true.

Martin Cross

(19) Japanese Patent Office (JP)
 (12) **Kokai Unexamined Patent Application Bulletin (A)**
 (11) **Laid Open Patent Application No.** 7-181900
 (43) **Publication Date** July 21, 1995
Number of Claims 15 FD
Number of Pages 14
Examination Request not yet made

(51)	Int. Cl. ⁶	Identification Code	Internal File No.	FI	Tech. Indic.
	G09F 9/00	363 Z	7610-5G		
	G02F 1/13	505			
	G09G 3/00	C	9378-5G		

(21) **Application No.:** 5-344760 (71) **Applicant:** 000001007
 Canon Inc.
 3-30-2 Shimomaruko,
 Ota-ku, Tokyo-to

(22) **Application Date:** December 21, 1993 (72) **Inventor:** MIYAJIMA, Yoshikazu
 Canon Inc.
 3-30-2 Shimomaruko,
 Ota-ku, Tokyo-to

(74) **Agent:** Patent Attorney, ITO, Tetsuya
 (and 1 other person)

(54) [Title of the Invention] Display Device

(57) [Abstract]

[Object] To provide a means for efficiently providing information based on image information within a vehicle.

[Constitution] In a display device comprising a plurality of displays 01 and a drive device 02 that performs display on the displays on the basis of stored image data, the display device is installed in a vehicle 03 and the displays are flat displays having shapes conforming to the shape of a region where the display is to be installed within the vehicle.

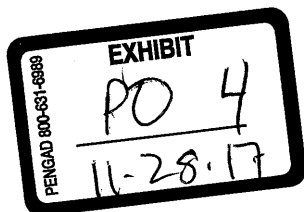
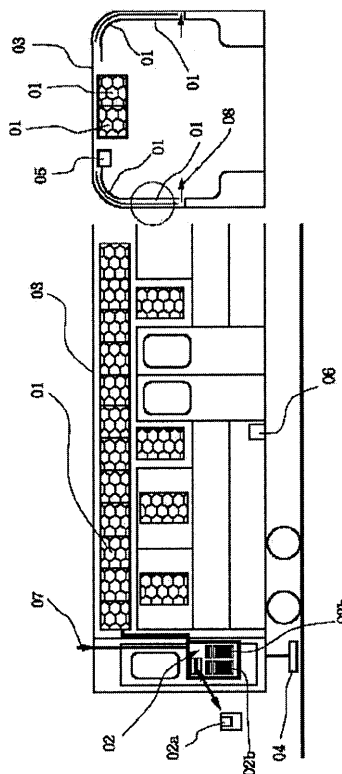

(2)

JP-07-181900-A

[CLAIMS]

[Claim 1] In a display device comprising a plurality of displays and a drive device that performs display on the displays on the basis of stored image data, the display device characterized in that the display device is installed in a vehicle and the displays are flat displays having shapes conforming to the shape of a region where the display is to be installed within the vehicle.

[Claim 2] The display device recited in claim 1, characterized in that the vehicle has a transparent glass part and the display constitutes part of the transparent glass part or is installed in the transparent glass part itself.

[Claim 3] The display device recited in claim 1, characterized in that the drive device changes the display content of the display in approximate synchronization with the movement or stopping of the vehicle.

[Claim 4] The display device recited in claim 1, characterized in that the displays are arranged adjacent to each other, and the drive device performs display so as to change the display content on each display or so that the display content continuously moves across adjacent displays.

[Claim 5] The display device recited in claim 1, characterized by comprising a means for detecting a movement position of the vehicle, wherein the drive device changes the display content on the display in accordance with a detection signal from this detection means.

[Claim 6] The display device recited in claim 1, characterized in that the vehicle has a door for shielding from the exterior, and the drive device changes the display content on the display in approximate synchronization with the opening and closing of this shielding door.

[Claim 7] The display device recited in claim 1, characterized in that the drive device has a means for transferring the image data to the displays, which accesses the stored image data in accordance with the vehicle movement or position, or the opening and closing of the door, and transfers the image data to the displays.

[Claim 8] The display device recited in claim 1, characterized in that the display device comprises a means for detecting changes in brightness in part of the vehicle, and the display comprises a backlight, the brightness of which changes in accordance with the output of this detection means.

[Claim 9] The display device recited in claim 1, characterized in that the drive device comprises an information memory search online transfer means provided within the vehicle, which stores the image data, and accesses and transfers the same, and a communication information transfer means, which receives and transfers image data that is transmitted from outside the vehicle, wherein display is performed on the displays on the basis of image data from this information memory search online transfer means and this communication information transfer means.

[Claim 10] The display device recited in claim 1, characterized by having a pair of displays that are installed with their backs facing each other and forming a certain angle.

[Claim 11] The display device recited in claim 1, characterized by having a pair of displays that are installed with their backs facing each other, wherein this pair of displays has a mutually shared backlight.

[Claim 12] The display device recited in claim 1, characterized in that the display comprises a backlight, and

the display device comprises a means for supplying a cooling air flow that cools this backlight via a gap between the display and the inner wall of the vehicle.

[Claim 13] The display device recited in claim 1, characterized in that the display comprises a backlight, and the display device comprises a means for supplying a cooling air flow that cools this backlight, and for discharging it to the exterior of the vehicle.

[Claim 14] The display device recited in claim 1, characterized in that the display is a surface-stabilized ferroelectric liquid crystal display, to which voltage is applied only when the display content changes and which otherwise maintains the display content without the application of voltage.

[Claim 15] The display device recited in claim 1, characterized in that the displays are one or more type of electronic display selected from a nematic liquid crystal display, a thin film transistor liquid crystal display, a surface-stabilized ferroelectric liquid crystal display, an antiferroelectric liquid crystal display, a plasma display, a light emitting diode display, an electron beam irradiation Braun tube display, an electroluminescent display, a plasma display, and a fluorescent tube display.

[Detailed Description of the Invention]

[0001]

[Field of Industrial Application] The present invention relates to a display device having a plurality of displays and a drive device for performing this display.

[0002]

[Prior Art] Conventionally, as shown in FIG. 27, image information such as announcements, maps and destination displays were provided within vehicles such as railway carriages, aircraft, buses and ships, by way of paper display using printed paper 101.

[0003]

[Problems to Be Solved by the Invention] However, there was a problem with this method, in so much as it was extremely difficult to change the content of the display. Further, there was a limit on the amount of information that could be supplied due to the limited space within the vehicle.

[0004] As a reflection of these conventional problems, an object of the present invention is to provide a means for efficiently providing information based on image information within a vehicle.

[0005]

[Means for Solving the Problems] In order to achieve this object, in the present invention, a display device comprising a plurality of displays and a drive device installed in a vehicle, which performs display on the displays on the basis of stored image data, flat displays having shapes conforming to the shape of a region where

(3)

JP-07-181900-A

the display is to be installed within the vehicle are used as the displays.

[0006] The drive device stores image data, which it searches for and delivers, and has a memory/search device such as an image information data searching device using various types of optical/magnetic recording media such as optical discs and hard discs, and rapidly displays images on the displays, on the basis of this image data.

[0007] If the vehicle has a transparent glass part, the display may constitute part of this transparent glass part, or be installed in this transparent glass part itself.

[0008] The drive device may change the display content of the display in approximate synchronization with the movement or stopping of the vehicle. Further, the displays may be arranged adjacent to each other, and the drive device may perform display so as to change the display content on each display or so that the display content continuously moves across adjacent displays. Furthermore, a means for detecting a movement position of the vehicle may be provided, wherein the drive device changes the display content on the display in accordance with a detection signal from this detection means. Furthermore, if the vehicle has a door for shielding from the exterior, the drive device may change the display content on the display in approximate synchronization with opening and closing of this shielding door. Further, the drive device may have a means for transferring the image data to the displays, which accesses the stored image data in accordance with the vehicle movement or position, or the opening and closing of the door, and transfers the image data to the displays.

[0009] The display device may comprise a means for detecting changes in brightness in part of the vehicle, and the display may comprise a backlight, the brightness of which changes in accordance with the output of this detection means.

[0010] The drive device may comprise an information memory search online transfer means provided within the vehicle, which stores image data, and accesses and transfers the same, and a communication information transfer means, which receives image data that is transmitted from outside the vehicle, wherein display is performed on the displays on the basis of image data from this information memory search online transfer means and this communication information transfer means.

[0011] This may have a pair of displays that are installed with their backs facing each other and forming a certain angle, or may have a pair of displays that are installed with their backs facing each other, while this pair of displays has a mutually shared backlight.

[0012] If the display comprises a backlight, the display device may comprise a means for supplying a cooling air flow that cools this backlight via a gap between the display and the inner wall of the vehicle. Furthermore, this may comprise a means for discharging this cooled air to the exterior of the vehicle.

[0013] The display may be a surface-stabilized ferroelectric liquid crystal display, to which voltage is applied only when the display content changes and which otherwise maintains the display content without the application of voltage. Furthermore, display may be performed by selecting and combining displays from nematic liquid crystal displays, thin film transistor liquid crystal displays, surface-stabilized

ferroelectric liquid crystal displays, antiferroelectric liquid crystal displays, plasma displays, light emitting diode displays, electron beam irradiation Braun tube displays, electroluminescent displays, plasma displays, and fluorescent tube displays, each matched to the types of image information and character information.

[0014]

[Operation] With this configuration, because the displays are flat displays having shapes conforming to the shapes in the regions where the displays are to be installed within the vehicle, the displays can be installed with efficient use of the space within the vehicle along the interior walls and the like, within the vehicle. Furthermore, in terms of the image data that is supplied to the displays, various image information items such as announcements, maps, destination guides, and railway maps are stored, and these are displayed on the displays with suitable switching, whereupon the content of the display is instantaneously changed, and thus multiple types of items are displayed. Accordingly, the content of the displays can be changed very easily, and the amount of information that can be displayed is increased, such that information can be supplied very efficiently within the vehicle, based on image information.

[0015]

[Embodiments]

(Embodiment 1) FIG. 1 is a schematic view illustrating a display device according to a first embodiment of the present invention. As shown in the drawing, this device is installed in a vehicle carriage 03, and comprises a plurality of displays 01, and a drive device (02 or the like) that stores image data and performs display on the displays on the basis thereof. Flat displays, having shapes conforming to the shape of the region in which the displays are to be installed within the vehicle carriage 03, are used as the displays 01.

[0016] Electronic-display displays comprising various electronic-display-control light emitting means, such as nematic liquid crystal displays (STN), thin film transistor liquid crystal displays (TFT), surface-stabilized ferroelectric liquid crystal displays (FLC), antiferroelectric liquid crystal displays (AFS), plasma displays, light emitting diode (LED) displays, electron irradiation displays, electroluminescent displays, and fluorescent tube displays can be used for the displays 01.

[0017] FIG. 2 shows the sectional structure of a liquid crystal display 01. Here, a liquid crystal 01A that controls the transmission of light is enclosed between a common electrode 01B and drive electrodes 01C. Furthermore, orientation films 01D and 01E, which orient the liquid crystal, are provided on the electrode surfaces, and a spacer 01F,

(4)

JP-07-181900-A

which maintains a specific space between the orientation films 01D and 01E, is provided therebetween. Color filters 01J are provided at the surface of the common electrode 01B, at each of the drive electrodes 01C, with protection film 01H therebetween. These color filters 01J and drive electrodes 01C are each trapped between glass substrates 01G and 01K. Polarizing films 01M, and 01L, which polarize the transmitted light that is transmitted through the liquid crystal, are affixed to the surfaces of the glass substrates 01G and 01K. Furthermore, a seal 01N is provided around the sides of the display 01, which seals the liquid crystal 01A. A backlight 01P is provided on one side of the liquid crystal panel that is configured in this manner, in order to irradiate transmitted light from one side of the liquid crystal panel, such that backlight-irradiated light 01Q is transmitted to the display 01. Furthermore, the structure is such that cooling air 08 passes by the backlight 01P, in order to limit the temperature-rise of the backlight 01P to no greater than a certain temperature. In FIG. 2, the structure is such that the cooling air 08 flows between the vehicle carriage 03 and the backlight.

[0018] Display data such as image data is transferred for display to the displays 01 by an electronic filing device 02, which has a data access means for various optical discs 02a, or magnetic disks such as hard disks or floppy disks, or various memory drive devices such as magnetic tape or semiconductor memories, and an autochanger 02b for optical discs or the like.

[0019] FIGS. 3 to 5 illustrate modes of installing the displays 01 in the vehicle carriage 03. That is to say, FIG. 3 shows the modes in which displays 01 having shapes conforming to the curved surface parts 03a of the inner walls of the carriage are installed in the vehicle carriage 03. FIG. 4 shows the mode in which the displays 01 are divided into flat displays 01a and 01b and installed in a shape conforming to the curved surface parts 03a of the inner walls in the vehicle carriage 03 with mutual angles between the flat displays 01a and 01b in a shape conforming to the curved surface parts 03a of the inner walls of the carriage. FIG. 5 shows the mode in which displays 01 are divided into a plurality of displays which are flat displays 01c to 01g and installed in a shape conforming to the curved surface parts of the inner walls of the carriage in the vehicle carriage 03, with mutual angles between the flat displays 01c to 01g conforming to the curved surface parts of the inner walls of the carriage.

(Embodiment 2) FIG. 6 is a schematic view illustrating a display device according to a second embodiment of the present invention. Here, backlights 01P are not provided on windows that are provided in the vehicle carriage 03, which is to say on transparent glass parts 03b, but rather the displays 01h are directly affixed, and display is performed as a result of the liquid crystal display appearing, brought about by external light from the exterior of the vehicle. Furthermore, as shown in FIG. 7, it is also possible to install this with a liquid crystal display 01 directly encased within the transparent glass part 03b.

(Embodiment 3) FIG. 8 is a schematic view illustrating a display device according to a third embodiment of the present invention. Here, as shown in FIG. 9, by way of a moving/stopping detection position-detecting sensor 04, which is provided on the vehicle carriage 03, from among the displays 01, image information is displayed on displays 01i and 01j when the carriage is stopped, and when the carriage

is moving, the movement of the carriage is detected by the moving/stopping detection position-detecting sensor 04, and from among the displays 01, the image information for the display 01j is changed by the electronic filing device, and then displayed.

(Embodiment 4) FIG. 10 and FIG. 11 are schematic views illustrating a display device according to a fourth embodiment of the present invention. Here, a plurality of images displayed on respective displays 01 are successively sent in the manner of display modes A1 to A2 and then A3, so as to move on the displays by changing the display content, in display [screen sized] units. Alternatively, a particular image ABC is progressively increased so as to be shown in the form of display modes B1 and B2. Alternatively, as shown with display modes C1 and C2, image information is displayed on the displays within the vehicle carriage in uninterrupted motion, by performing continuous moving display of certain image information across adjacent displays.

(Embodiment 5) FIG. 12 and FIG. 13 are schematic views illustrating a display device according to a fifth embodiment of the present invention. Here, as shown in FIG. 13, by way of a moving/stopping detection position-detecting sensor 04, which is provided on the vehicle carriage 03 and detects the position of the vehicle carriage, when the vehicle carriage has moved from a carriage stop position A to a carriage stop position B, the position of the vehicle carriage is detected by the moving/stopping detection position-detecting sensor 04 and, on the basis thereof, from among the display images 01i and 01j on the display 01, the electronic filing device 02 changes the content displayed for the display image 01j.

(Embodiment 6) FIG. 14 is a schematic view illustrating a display device according to a sixth embodiment of the present invention. Here, by way of an opening and closing detection sensor 06 for the opening and closing doors 03C provided on the vehicle carriage 03, when the opening and closing doors 03C have gone from an open state to a closed state, as shown in FIG. 15, from among the display images 01i and 01j on the display 01, the display image displayed on 01j is changed by the electronic filing device 02, on the basis of an opening and closing detection signal from the opening and closing sensor 06.

(Embodiment 7) FIG. 16 is a schematic view illustrating a display device according to a seventh embodiment of the present invention. Here, by way of a brightness sensor 05 that is provided within the vehicle carriage 03, changes in brightness at the interior and exterior of the vehicle are detected, and when the brightness outside the vehicle has changed from a daytime bright state to an evening dark state as shown in FIG. 17, the brightness of the backlight 01P provided on the display 01 is adjusted in accordance with the brightness sensor 05 so as to control the brightness so that the display image can easily be recognized.

(Embodiment 8) FIG. 18 is a schematic view illustrating a display device according to an eighth embodiment of the present invention. Here, an antenna 07 is provided on the electronic filing device 02 that is provided on the vehicle carriage, in order to receive communication information from the exterior; and communication information images are displayed on the displays 01 by way of receiving image information, in an external communication, which is different from the image information that is stored in the electronic filing device itself. For example, by changing some of the

(5)

JP-07-181900-A

display content, from display of the image that is stored in the electronic filing device itself as shown in FIG. 18, to an external communication information image as shown in FIG. 19, image information from within the vehicle, and from outside the vehicle, is suitably displayed on the display 01 within the vehicle carriage 03.

(Embodiment 9) FIG. 20 is a schematic view illustrating a display device according to a ninth embodiment of the present invention. Here, in the vehicle carriage, two displays 01k are installed so as to face each other back-to-back [suspended] from the ceiling in the center of the carriage, at vertical angles relative to each other, and a backlight is installed at the back of each of the displays.

(Embodiment 10) FIG. 21 is a schematic view illustrating a display device according to a tenth embodiment of the present invention. Here, in the vehicle carriage, two displays 01n are installed united so as to face each other back-to-back [suspended] from the ceiling in the center of the carriage as shown in the figure, and a common backlight 01p is provided between the two displays.

(Embodiment 11) FIG. 22 is a schematic view illustrating a display device according to an eleventh embodiment of the present invention. Here, backlights 01t and 01r are respectively provided at the back of the displays, for displays 01s and 01r, which are provided in the vehicle carriage, and a cooling air passage gap 03c is provided between the vehicle carriage 03 and the backlights 01t and 01r, in which cooling air 08 flows, which cools the backlights.

(Embodiment 12) FIG. 23 is a schematic view illustrating a display device according to a twelfth embodiment of the present invention. Here, cooling air that has passed through the cooling air passage gap 03c is discharged to the exterior by an exhaust fan 09, directed to the exterior, from the ceiling of the vehicle carriage.

(Embodiment 13) FIG. 24 is a schematic view illustrating a display device according to a thirteenth embodiment of the present invention. Here, as shown in FIG. 24, surface-stabilized ferroelectric liquid crystal displays (FLC) 11, 12 and 13, which, once a voltage has been applied during image formation, have the capacity for image memory even if voltage is not applied, and a thin film transistor liquid crystal display (TFT) 10, which does not have image memory capacity, but which has a rapid display-switching speed and is suitable for high definition color display, are installed as the displays; and images that are infrequently changed after having been once formed are displayed at all times by the displays 11 to 13, while images that are frequently changed at all times, or for which moving image display is necessary, are displayed by the display 10, such that the display content is changed from the display image 10a to 10b only on the displays 10, as shown in FIG. 25.

(Embodiment 14) FIG. 26 is a schematic view illustrating a display device according to a fourteenth embodiment of the present invention. Here, various types of displays suited to the display images are provided at different positions within the vehicle carriage 03. From among the display-installation regions within the vehicle, curved surface displays 14 such as nematic liquid crystal displays that use flexible transparent cover electrodes, light emitting diodes (LED) and the like, which can easily be configured for curved surface displays, are used for the curved surface regions. Liquid crystal displays 15 such as nematic liquid crystal displays

(STN/LCD), thin-film transistor liquid crystal displays (TFT), surface-stabilized ferroelectric liquid crystal displays (FLC) and antiferroelectric liquid crystal displays (AFS), which can perform display with external light as a backlight, are used for the glass windows 18 of the vehicle carriage. Furthermore, thin multi-electron-beam-irradiation CRTs, plasma displays, thin-film transistor liquid crystal displays (TFT) or the like, having relatively rapid response speeds, are used for the moving-image-display displays 16 on the walls within the vehicle. Furthermore, a display, such as one in which a multiplicity of light emitting diodes (LED) are aligned, is used as a band-shaped elongate mounted display 17 for simple display of characters alone, which extends in the lengthwise direction of the vehicle carriage as shown in FIG. 26.

[0020] Note that, in the embodiments, a railway carriage or the like was described as an example of the vehicle, but it is conceivable that this be applied to other vehicles such as aircrafts, ships, buses, elevators, recreational facilities and the like.

[0021]

[Effects of the Invention] As described above, by virtue of the present invention, a means can be provided for efficiently supplying information based on image information within a vehicle.

[0022] In other words: (1) the display efficiency, such as in the changing of displays, can be markedly increased by efficient installation in which displays for display of announcements, guidance and the like, which are to be displayed within the vehicle, are made electronic; (2) information such as communication information, which could not be displayed in the past, can be displayed; (3) by moving display images across a plurality of displays, the display content can be seen in all places within the vehicle; and (4) it is possible to automatically and suitably control the display content and the display mode in accordance with stopping of the vehicle, changes in brightness within the vehicle, opening and closing of doors and the like.

[Brief Description of the Drawings]

[FIG. 1] This is a schematic view illustrating a display device according to the first embodiment of the present invention.

[FIG. 2] This is a sectional view showing the sectional structure of the liquid crystal display in the device in FIG. 1.

[FIG. 3] This is a schematic view illustrating modes of installing the displays in the device in FIG. 1 in a vehicle carriage.

[FIG. 4] This is a schematic view illustrating other modes of installing the displays in the device in FIG. 1 in a vehicle carriage.

[FIG. 5] This is a schematic view illustrating still other modes of installing the displays in the device in FIG. 1 in a vehicle carriage.

[FIG. 6] This is a schematic view illustrating a display device according to the second embodiment of the present invention.

[FIG. 7] This is a schematic view illustrating the manner in which a liquid crystal display is installed so as to be directly encased within the transparent glass part in the device in FIG. 6.

[FIG. 8] This is a schematic view illustrating a display device according to the third embodiment of the present invention.

[FIG. 9] This is a schematic view illustrating a change in the display state of the display in the device in FIG. 8.

(6)

JP-07-181900-A

[FIG. 10] This is a schematic view illustrating a display device according to the fourth embodiment of the present invention.
 [FIG. 11] This is a schematic view illustrating a change in the display state of the display in the device in FIG. 10.
 [FIG. 12] This is a schematic view illustrating a display device according to the fifth embodiment of the present invention.
 [FIG. 13] This is a schematic view illustrating a change in the display state of the display in the device in FIG. 12.
 [FIG. 14] This is a schematic view illustrating a display device according to the sixth embodiment of the present invention.
 [FIG. 15] This is a schematic view illustrating a change in the display state of the display in the device in FIG. 14.
 [FIG. 16] This is a schematic view illustrating a display device according to the seventh embodiment of the present invention.
 [FIG. 17] This is a schematic view illustrating the manner in which the backlight brightness is adjusted so as to control the display image at a brightness that is easily recognized when there is a change in the brightness outside the vehicle, from a daytime bright state to an evening dark state.
 [FIG. 18] This is a schematic view illustrating a display device according to the eighth embodiment of the present invention.
 [FIG. 19] This is a schematic view illustrating the manner in which some of the display content is changed to the external communication information image, in the device in FIG. 18.
 [FIG. 20] This is a schematic view illustrating a display device according to the ninth embodiment of the present invention.
 [FIG. 21] This is a schematic view illustrating a display device according to the tenth embodiment of the present invention.
 [FIG. 22] This is a schematic view illustrating a display device

according to the eleventh embodiment of the present invention.
 [FIG. 23] This is a schematic view illustrating a display device according to the twelfth embodiment of the present invention.
 [FIG. 24] This is a schematic view illustrating a display device according to the thirteenth embodiment of the present invention.
 [FIG. 25] This is a schematic view illustrating a change in the display state of the display in the device in FIG. 24.
 [FIG. 26] This is a schematic view illustrating a display device according to the fourteenth embodiment of the present invention.
 [FIG. 27] This is a schematic view illustrating a method of displaying image information within the vehicle according to a conventional example.
[Explanation of the Symbols]
 01: display, 01A: liquid crystal, 01B: common electrode, 01C: drive electrode, 01D, 01E: orientation film, 01F: spacer, 01G: glass substrate, 01H: protective film, 01J: color filter, 01K: glass substrate, 01L, 01M: polarizing film, 01N: seal, 01P: backlight, 01Q: backlight irradiation light, 02: electronic filing device, 03: vehicle carriage, 03a: curved part of the inner walls of the carriage, 03b: transparent glass part, 03c: cooling air passage gap, 04: moving/stopping detection position-detecting sensor, 05: brightness sensor, 06: open/close detection sensor, 07: antenna, 08: cooling air, 09: exhaust fan, 10: thin-film transistor liquid crystal display (TFT), 11 to 13: surface-stabilized ferroelectric liquid crystal display (FLC), 14 to 17: various displays.

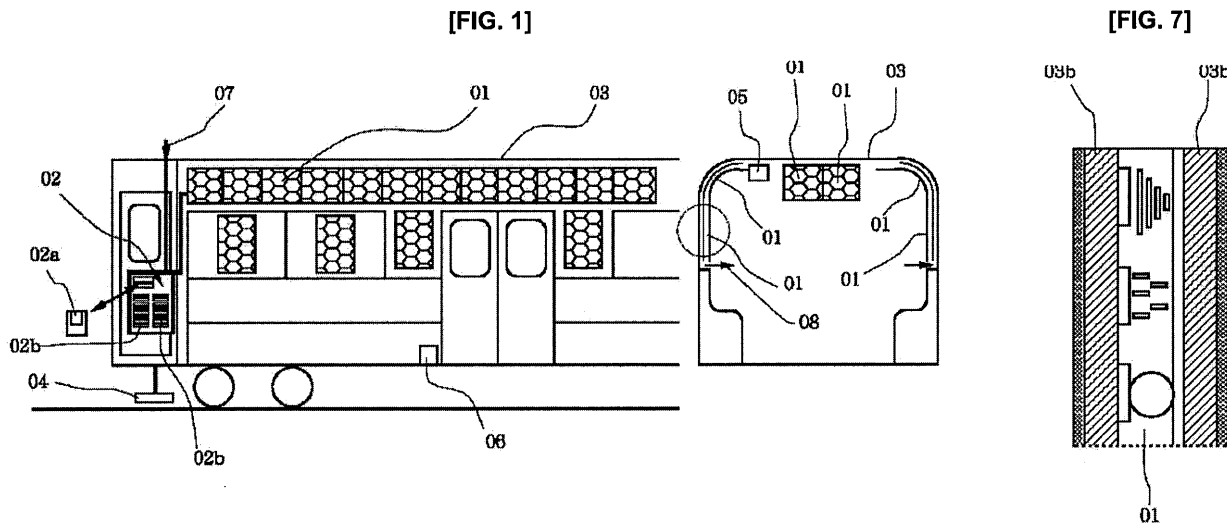

(7)

JP-07-181900-A

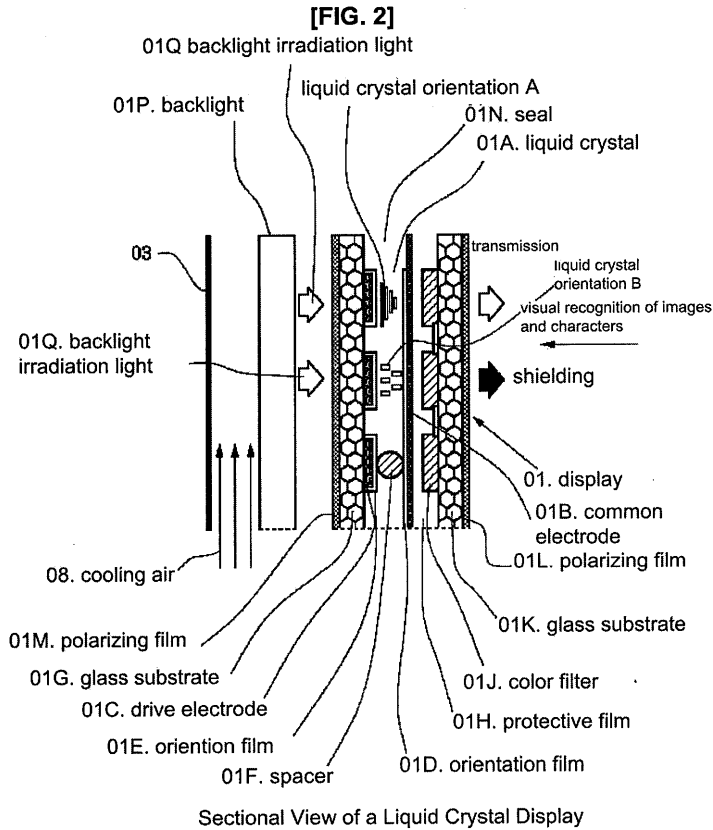

[FIG. 11]

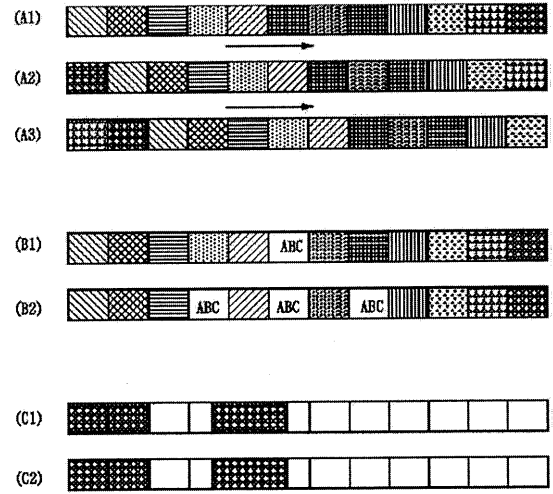

[FIG. 3]

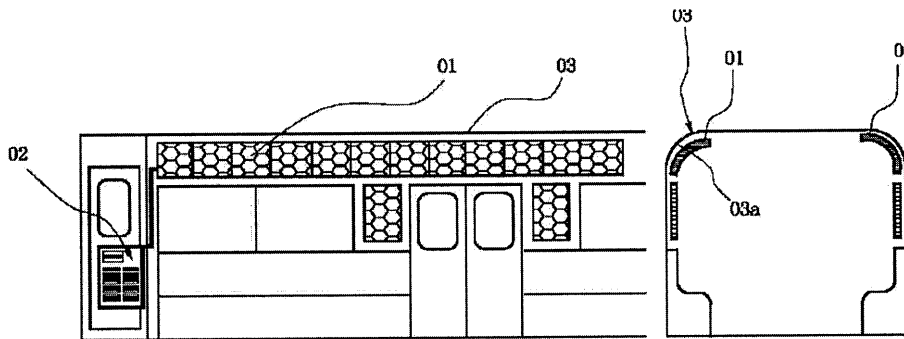

[FIG. 4]

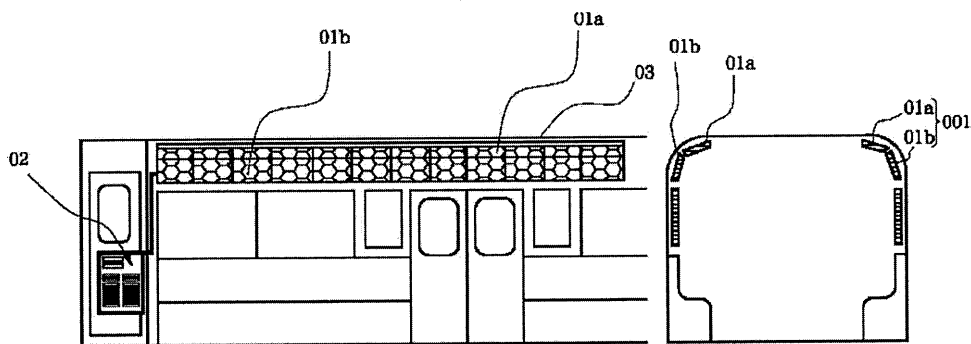

(8)

[FIG. 5]

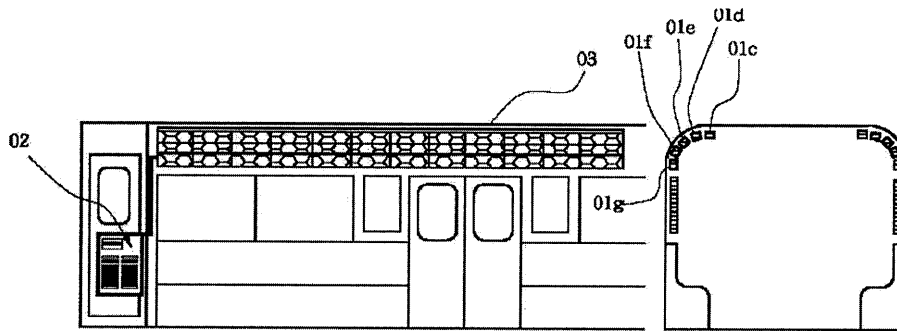

[FIG. 6]

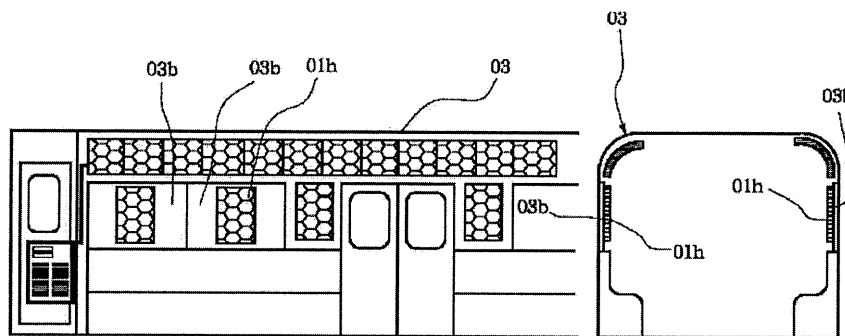

[FIG. 8]

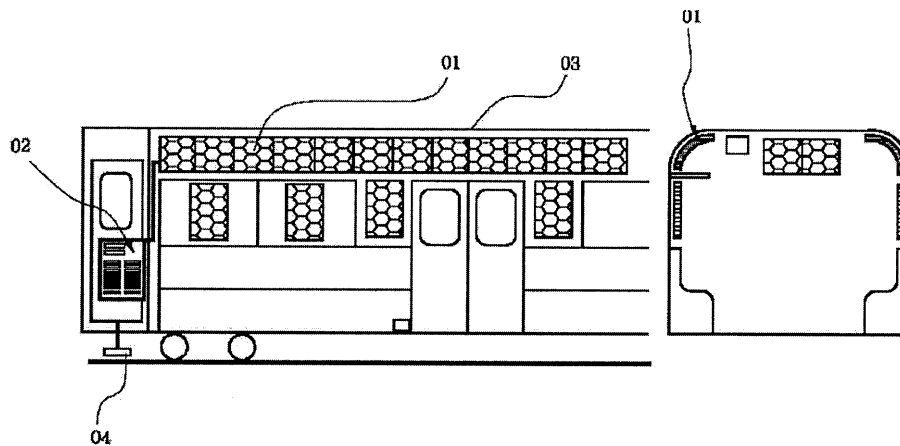

(9)
[FIG. 9]

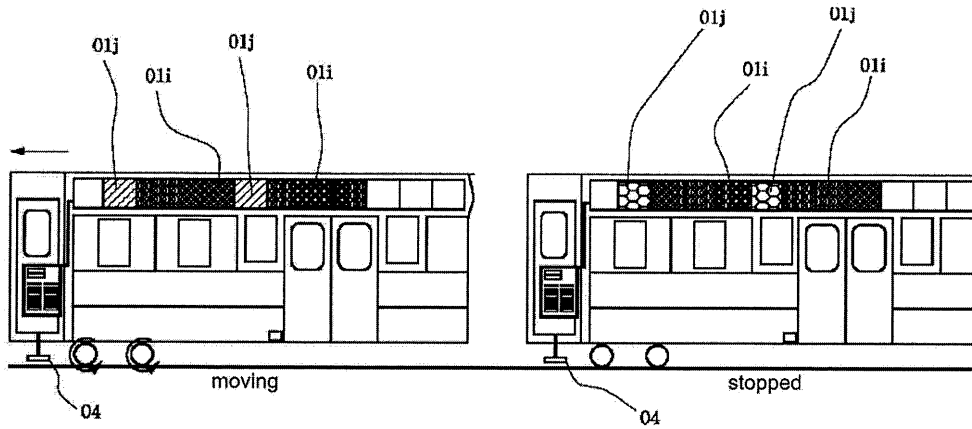

[FIG. 10]

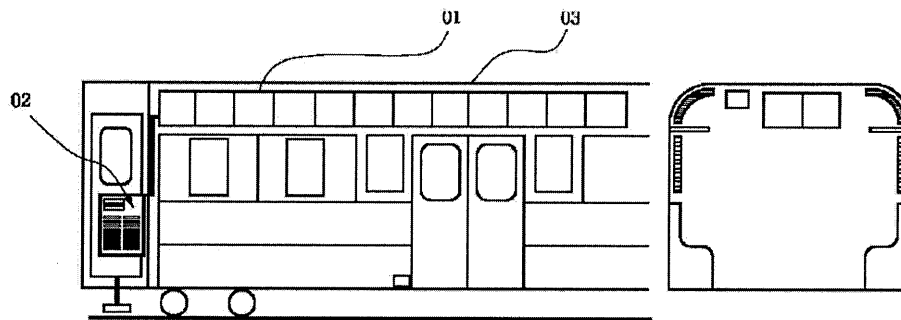

[FIG. 12]

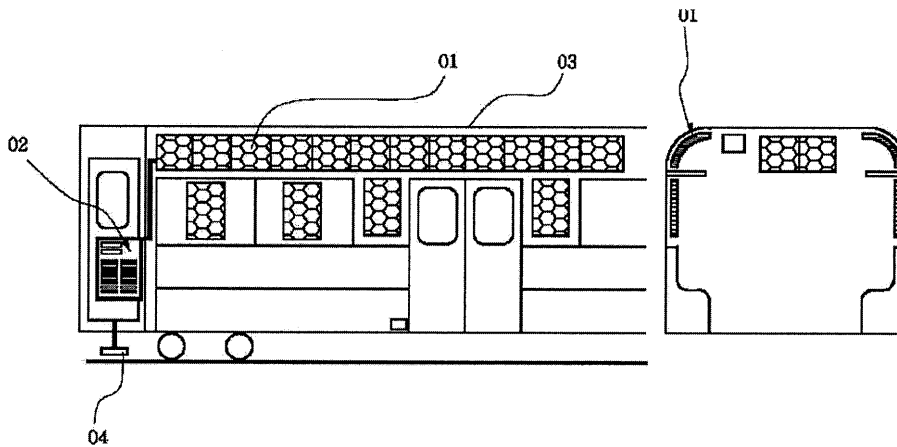

(10)
[FIG. 13]

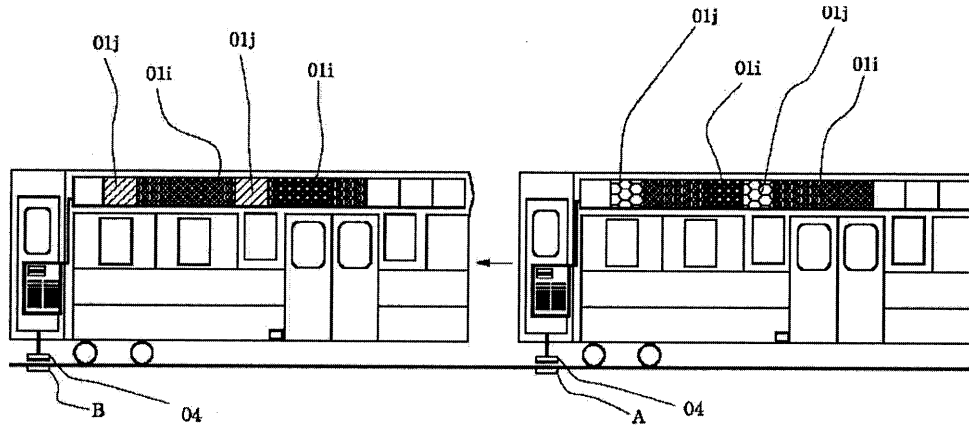

[FIG. 14]

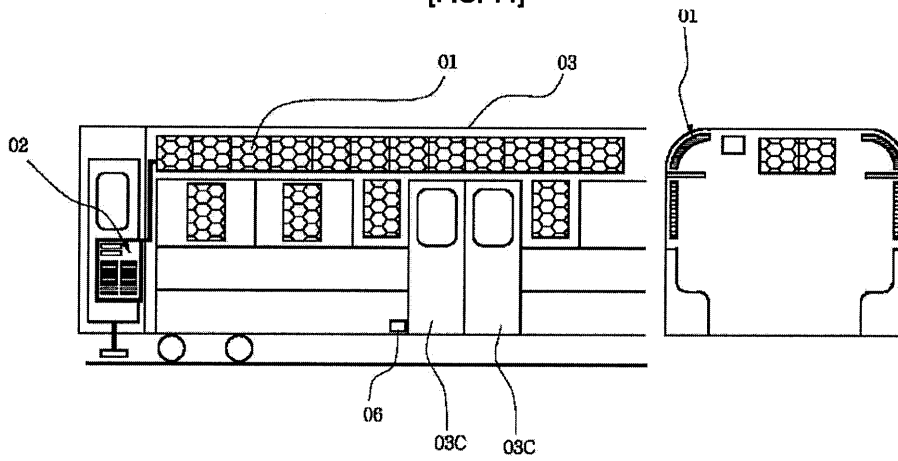

[FIG. 15]

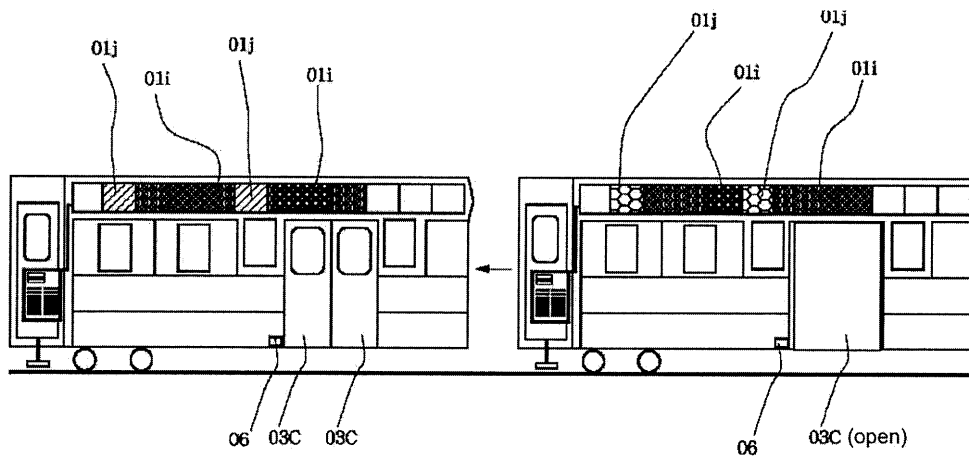

(11)
 [FIG. 16]

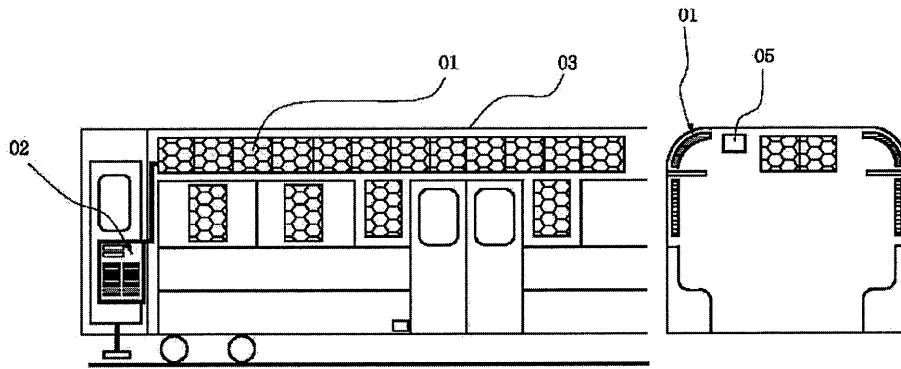

[FIG. 17]

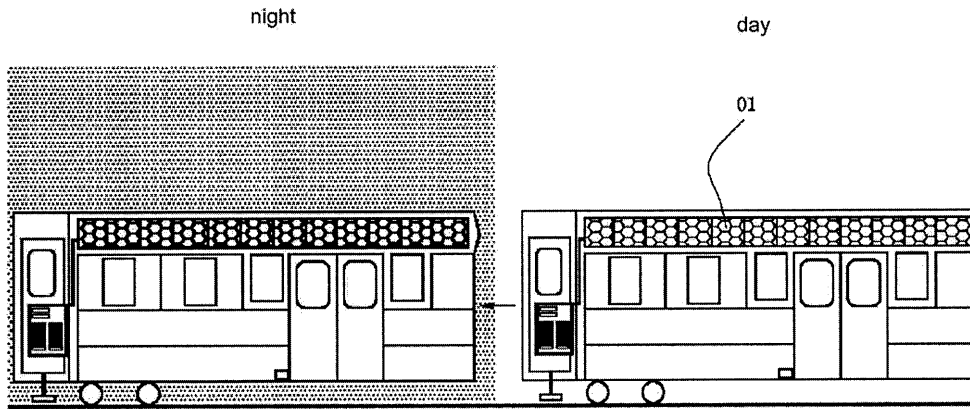

[FIG. 18]

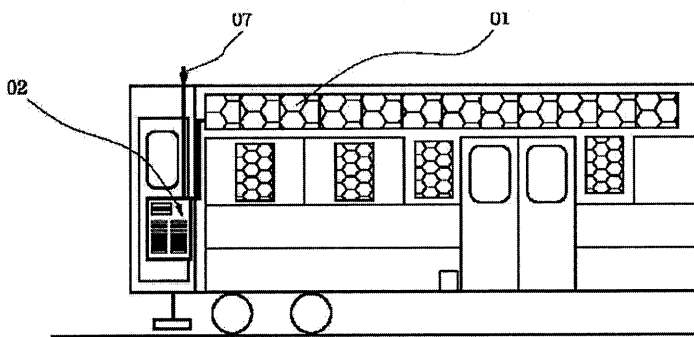

[FIG. 22]

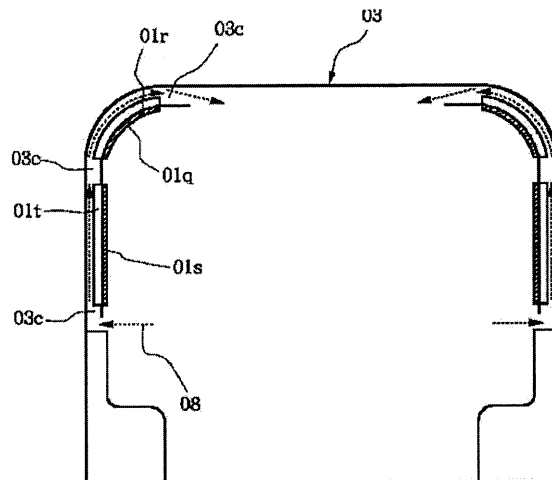

(12)

[FIG. 19]

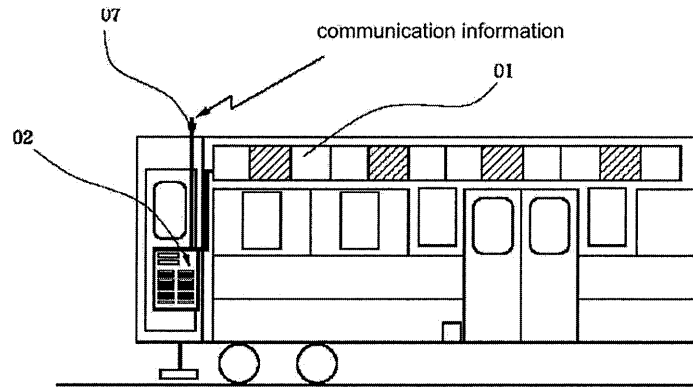

[FIG. 20]

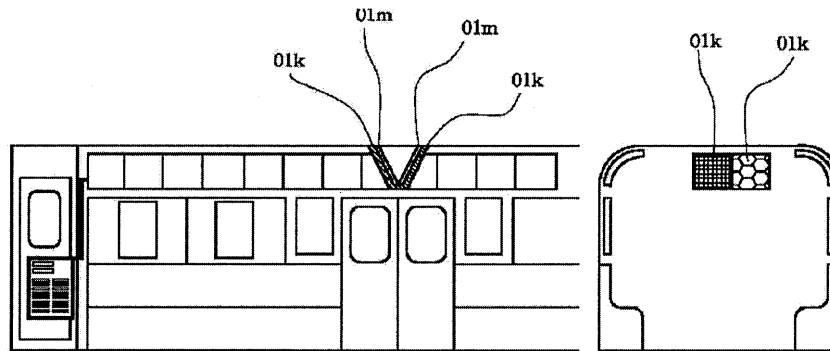

[FIG. 21]

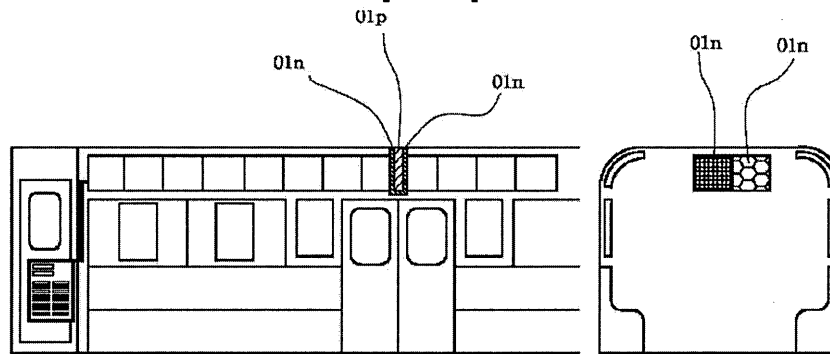

(13)

JP-07-181900-A

[FIG. 23]

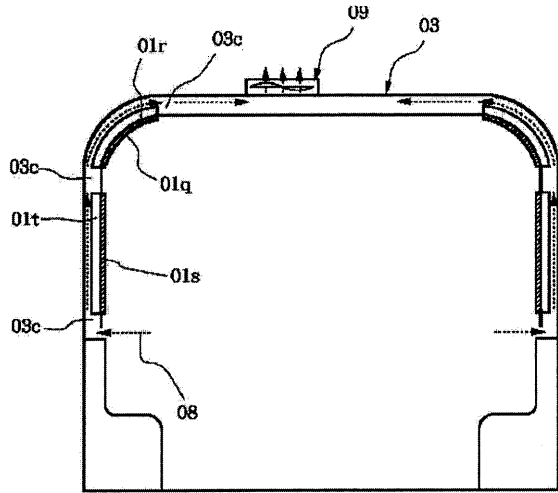

[FIG. 24]

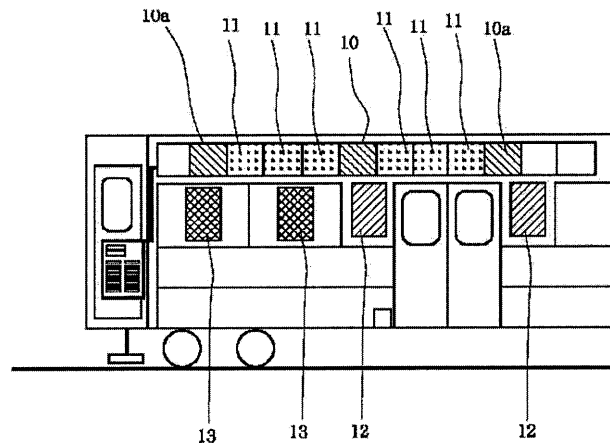

[FIG. 25]

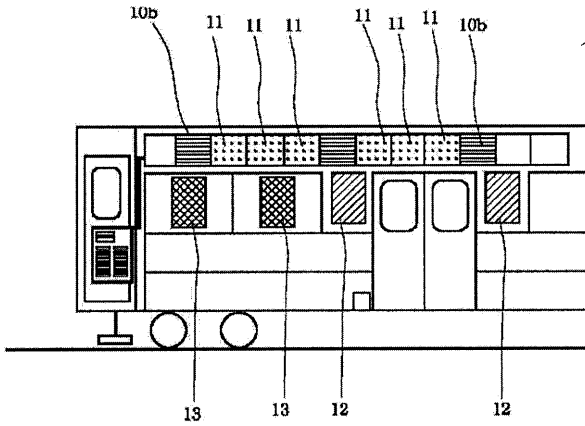

[FIG. 26]

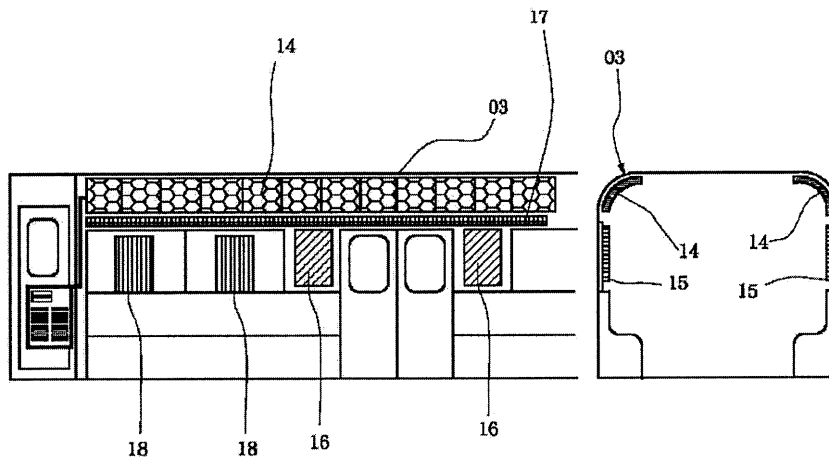

(14)
[FIG. 27]

JP-07-181900-A

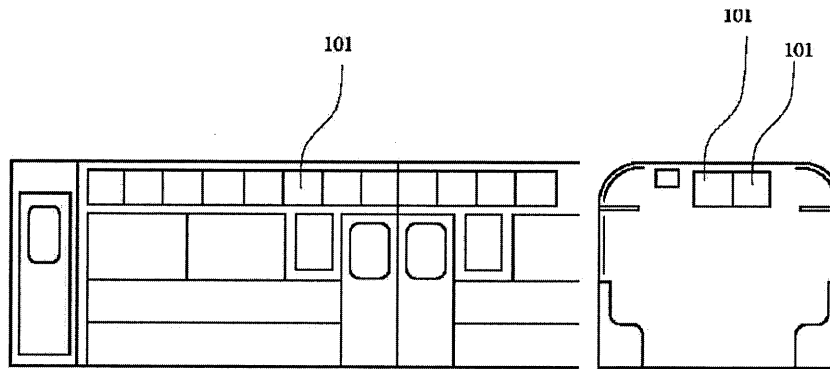

 **Patent Translations Inc.**

1700 Seventh Avenue, Suite 2100 mail@PatentTranslations.com
Seattle, WA 98101, USA http://www.PatentTranslations.com
Fax: 206-299-3692 Tel: 206-357-8508

Certification of Translation

Translator's Declaration: August 19, 2016

I, Martin Cross, hereby declare:

That I possess advanced knowledge of the Japanese and English languages. My qualifications are as follows:

- over 25 years as a Japanese-English translator focusing primarily on patents, and technical and scientific documents;
- co-author of the *Japanese Patent Translator's Handbook*, published by American Translators Association;
- United States district court recognition as an expert in Japanese technical translation for patent litigation; and
- work experience including design and testing of electronic circuits for Research and Development Laboratories Waterloo Ltd.

The attached translation is, to the best of my knowledge and belief, a true and accurate translation from Japanese to English of Japanese Unexamined Patent Application Number JP-07-181900-A. I understand that willful false statements and the like are punishable by fine or imprisonment, or both (18 U.S.C. 1001), and may jeopardize the validity of the application or any patent issuing thereon. I declare under penalty of perjury that all statements made herein of my own knowledge are true, and all statements made on information and belief are believed to be true.

Martin Cross

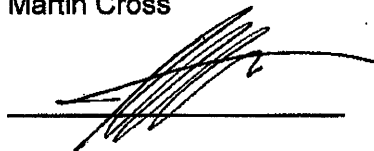

(19) Japanese Patent Office (JP)

(12) Kokai Unexamined Patent
 Application Bulletin (A)

(11) Laid Open Patent Application No.

4-322579

(43) Publication Date: Nov. 12, 1992

(51) Int. Cl. ⁵	Identification Code	Internal File No.	FI	Tech. Indic.
H04N 5/64	501 D	7205-5C		
E04F 19/08	102 Z	7151-2E		
G03B 21/10	D	7316-2K		
G09F 19/22	D	6447-5G		
H04N 5/74	F	7205-5C		

Examination Request: not yet made Number of Claims: 2 Number of Pages 5

(21) Application No.:	3-90761	(71) Applicant:	000005016 Pioneer Corporation 1-4-1 Meguro, Meguro-Ku, Tokyo-to
(22) Application Date:	April 22, 1991	(72) Inventor:	SASAO, Minoru Pioneer Corporation Omori Factory, 4-15-5 Omorinishi, Ota-Ku, Tokyo-to
		(74) Agent:	Patent Attorney, ISHIKAWA, Yasuo (and one other person)

(54) Title of the Invention: Display Device

(57) [Abstract]

[Object] To provide a display device with which the perceived presence of the cabinet can be entirely eliminated, such that only the necessary image is produced.

[Configuration] This comprises: a main display unit disposed at an opening that is formed in a wall of a room in a building, with the front face of an image formation part facing the interior of the room; and a frame member, which is engaged on the main display unit, disposed at the periphery of the image formation part, so as to cover a gap between the main display unit and the edge of the opening.

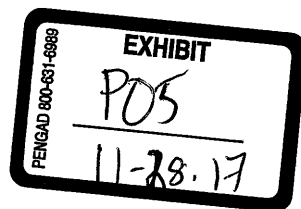
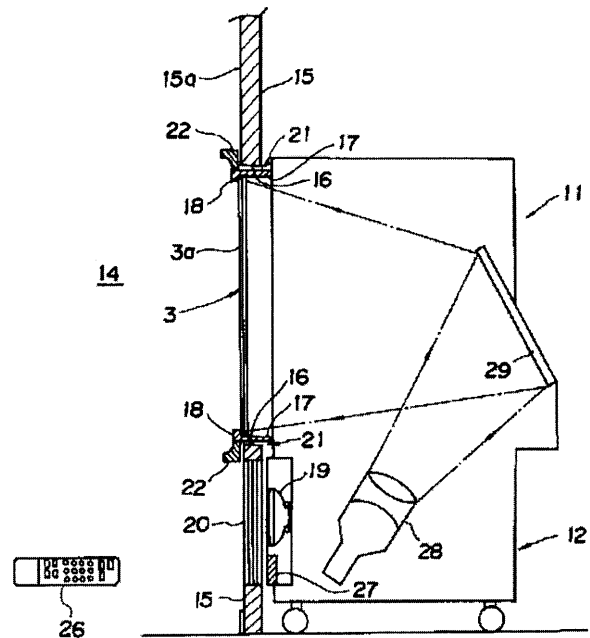

[Claims]

[Claim 1] A display device characterized by comprising: a main display unit disposed at an opening that is formed in a wall of a room in a building, with the front face of an image formation part facing the interior of the room; and a frame member, which is engaged on the main display unit, disposed at the periphery of the image formation part, so as to cover a gap between the main display unit and the edge of the opening.

[Claim 2] The display device according to claim 1, characterized in that an engagement part is formed on the main display unit, and desired frame members can be exchanged on this engagement part.

[Detailed Description of the Invention]**[0001]**

[Field of Industrial Application] The present invention relates to a display device such as a rear projection television, and in particular relates to a display device that is structured so as to be housed at the interior of a wall.

[0002]

[Prior Art] Rear projection televisions as mentioned above have built-in CRTs for R (blue [sic]), G (green) and B (blue), and the colored light that is emitted from each of these CRTs irradiates the back face of a screen mounted in a cabinet so as to form a color image on the front face of the screen. Such rear projection televisions, or ordinary market available televisions that use a normal CRT, are normally used by placing them in the living room of an ordinary residence or in a viewing room in a commercial building.

[0003]

[Problems to Be Solved by the Invention] However, the aforementioned rear projection televisions and ordinary televisions alone take up their own space when set up in rooms, and the perceived presence of the main television unit is strongly felt. In particular, as the cabinets of the aforementioned rear projection televisions were normally large, they occupied a large amount of space when set up in a room, and thus the perceived presence thereof was even greater. Furthermore, there were problems in so much as large rear projection television devices were in the way, and made the room smaller, and in particular in cases such as that of an ordinary residence with small rooms, it was not possible to view them from more than a predetermined distance from the screen.

[0004] The presence of such cabinets reduced the concentration of the viewer on the content of the images that were displayed on the screen, such that the presence of the cabinet itself had a negative impact, constituting what might be termed a noise factor. The present invention was made in order to solve such problems, and an object thereof is to produce a display device that can entirely eliminate the perceived presence of the cabinet.

[0005] Furthermore, an object is to produce a display device that allows the frame member to be freely selected in keeping with the content of the image.

[0006]

[Means for Solving the Problems] The display device according to the present invention comprises: a main display unit disposed at an opening that is formed in a wall of a room in a building, with the front face of an image formation part facing the interior of the room; and a frame member, which is engaged on the main display unit, disposed at the periphery of the image formation part, so as to cover a gap between the main display unit and the edge of the opening.

[0007] Furthermore, it is preferable that an engagement part be formed on the main display unit, and that desired frame members can be exchanged on this engagement part.

[0008]

[Operation] In the present invention, the front face of the image formation part of the main display unit is disposed in an opening formed in a wall of the room, and the cabinet of the main display unit is installed outside of the room, such that only the front face of the image formation part can be seen from within the room.

[0009]

[Embodiments] Hereafter, an embodiment of the present invention will be described based on the drawings. FIG. 1 shows an ordinary market available rear projection television 1, which is set up in a room; the rear projection television 1, serving as the main display unit, has a cabinet 2; and electronic components and optical components for forming a color image on the front face of a screen 3, serving as the image formation part, are housed within the cabinet 2.

[0010] In the present invention, this rear projection television 1 can be used as is, but in a preferred embodiment, one wherein this rear projection television 1 is partially modified, as shown in FIG. 2, is used. That is to say, as shown in FIGS. 2 and 3, a rear projection television 11 serving as a main display unit according to the present embodiment is disposed with a front face 3a of a rectangular screen 3, which serves as the image formation part, facing the interior of a room 14, at an opening 16 that is formed in a wall 15 of the room 14, in an ordinary residential or commercial building. The front face 3a of the screen 3, which is provided at the front (to the left in FIG. 2) of the cabinet 12 of such a rear projection television 11, is positioned forward of the front 12a of the cabinet 12 by a distance D_1 (for example, $D_1 = 25$ mm); this distance D_1 is made greater than the distance D_2 (for example, $D_2 = 10$ mm) between the front 6 of the cabinet and the front face 3a of the screen of the market available rear projection television 1 shown in FIG. 1. The cabinet 12 itself is disposed behind the wall 15 and cannot be seen from within the room 14; furthermore, as described above, the screen 3 protrudes forward from the cabinet 12 so that the front face 3a of the screen and the wall surface 15a in the room 14 are substantially flush. Reference numeral 17 [indicates] a support member (screen frame), which protrudes forward from the cabinet 12 and is rectangular as seen from the front, the back end of which is attached to the front 12a of the cabinet 12, and supports the screen 3 with an engagement part 18 at the front end thereof; this is normally made from a plastic or aluminum material. This support member 17 is preferably such that the width of the member as seen from the front is

as thin and narrow as possible (for example, a width of 3 mm). Thus, with the rear projection television 11 shown in FIG. 2, the screen 3 is positioned further forward than that of the rear projection television 1 shown in FIG. 1 by a distance ($D_1 - D_2$) (for example, 15 mm) and therefore the electronic components and optical components serving to form a clear color image on the front face 3a of this screen 3 are disposed so as to be shifted forward by the necessary distance (for example 15 mm).

[0011] Furthermore, in the rear projection television 1 shown in FIG. 1, Saran net 7 for covering a speaker and support members 8a, 8b that support this Saran net 7 are provided below the front 6 of the cabinet 2, but in the rear projection television 11 shown in FIG. 2, such Saran net 7 and support members 8a, 8b are eliminated [sic]. In their place, as shown in FIG. 3, a speaker Saran net 20 is formed in the wall 15, in front of the speaker 19 that is mounted on the lower front of the cabinet 12, corresponding to the position of this speaker 19, whereby the sound that is generated by the speaker 19 passes through the speaker Saran net 20, and reaches the interior of the room 14.

[0012] Further, in the present invention, a frame a member 22 is disposed at the peripheral edge of the screen 3, which covers a gap 21 between the rear projection television 11 and the edge of the opening 16 in the wall 15, this frame member 22 engaging on the rear projection television 11. As a more preferred mode for the present embodiment, an engagement part 23 is formed at the outer peripheral face of the support member 17, in the vicinity of the forward end thereof, which allows the frame member 22 to be replaced by way of engagement and disengagement, when the rear projection television 11 has been positioned by way of inserting the support member 17, which supports the screen 3, into the opening 16 in the wall 15. This engagement part 23 may have a flat surface but, preferably, a groove-like height differential is formed so that the frame member 22 will not accidentally fall off of this engagement part 23 but rather the frame member 22 can be held with a suitable force, and so that it can be mounted or dismounted with a single operation. Furthermore, this frame member may be fixed in place in an easily mountable and dismountable manner, by way of Velcro or screw members in positions that cannot be seen from within the room.

[0013] It will be noted that, as shown in FIG. 3 and 4, the cabinet 12 of the rear projection television 11 is set up behind the wall 15, and therefore requires no decoration whatsoever, but ordinary decoration is provided on the support member 17 and the frame member 22, which are exposed to the interior of the room. In particular, it is possible to prepare multiple types of frame members 22 on which differing decoration is provided, such as providing a frame 24 that gives a heavy impression when still images such as pictures 100 or the like are [displayed] (FIG. 5) and providing a frame 25 that has a plain feel when other images (for example moving images such as a television broadcast) are [displayed] (FIG. 6), and to select the frame member 22 with the most suitable decoration for the content of the image that is formed on the screen 3, and engage this on the engagement part 23 of the support member 17, allowing only the image on the screen 3 and the frame member 22 to be seen, while the cabinet 12 itself cannot be seen at all from the interior of the room 14. In particular, when a BGV videotape is used so as to form a still image such as scenery on the screen 3, it is possible to achieve an unexpected effect wherein it seems as if a picture having a

(3)

JP-04-322579-A

frame has been hung on the wall surface 15a, and to produce a comfortably harmonious feeling, without the design of the frame producing a discordant feeling with respect to the content of the image. Meanwhile, when a television broadcast is received, it is preferable to use a frame member 22 that is merely a frame, with which the perceived presence of the frame can be abstracted to as great an extent as possible.

[0014] Note that, in order to operate this rear projection television 11, a portable controller 26 having an infrared emitter unit is placed within the room 14, and infrared signals are emitted from this controller 26. The emitted infrared signals pass through the speaker Saran net 20, whereafter they are received by an infrared receiver unit 27, which is installed facing forward in the vicinity of the speaker 19, and command signals are output to the electronic components and optical components within the cabinet 12, from this infrared receiver unit 27. Consequently, colored light emitted from a CRT lens-block 28 is reflected by a reflector 29, and then irradiates the back face of the screen 3, forming a color image on the front face 3a of the screen 3.

[0015] Furthermore, with the present embodiment, the cabinet 12 is set up behind the wall 15, and therefore it is not necessary to provide decoration on this cabinet 12 itself, allowing for cost reductions in terms of the materials and the decoration for the cabinet 12. Further, safety can be improved by making this cabinet 12 out of a material having good fire resistance. Furthermore, when the rear projection television 11 is off and no image is formed on the screen 3, the frame member 22 (or the frame 24 or 25) on which decoration has been provided constitutes an effective part of the interior design of the room 14.

[0016] Note that, in the embodiment described above, a case was shown in which the rear projection television 11 served as the main display unit, but an ordinary television having a CRT may serve as the image formation part. Furthermore, the type of wall as well as the material therefor, the color thereof and the like may be freely chosen, and there are no restrictions on the location of the wall, such that opening can be provided at a desired location in the wall and the rear projection television 11 can be set up there.

[0017]

[Effects of the Invention] Because the present invention according to claim 1 is configured as described above, only the image formation part will be seen from the interior of the room, without the main display unit being seen at all, which eliminates the perceived presence of the main display unit, allowing only the necessary image to be produced, and because the gap between the main display unit and the opening in the wall is covered by the frame member, the gap is not exposed to the interior of the room.

[0018] Furthermore, because the present invention according to claim 2 is configured as described above, it is possible to achieve harmony between the image and the frame member by freely selecting the frame member according to the content of the image on the image formation part.

[Brief Description of the Drawings]

[FIG. 1] This is a side view of a market available rear projection television.

[FIG. 2] This is a side view of a rear projection television showing one embodiment of the present invention.

[FIG. 3] This is a side structural view showing the situation in which the rear projection television shown in FIG. 2 has been set up at an opening in a wall.

[FIG. 4] This is an explanatory diagram serving to explain the situation in FIG. 3.

[FIG. 5] This is a front view of the situation in which a frame for the rear projection television shown in FIG. 2 has been mounted.

[FIG. 6] This is a front view of the situation in which another frame for the rear projection television shown in FIG. 2 has been mounted.

(4)

[Explanation of the Symbols]

- 1, 11 ...rear projection television (main display unit)
- 3 ...screen (image formation part)
- 3a ...front face
- 14 ...room
- 15 ...wall
- 16 ...opening
- 21 ...gap
- 22 ...frame member
- 23 ...engagement part
- 24, 25 ...frame (frame member)

[FIG. 1]

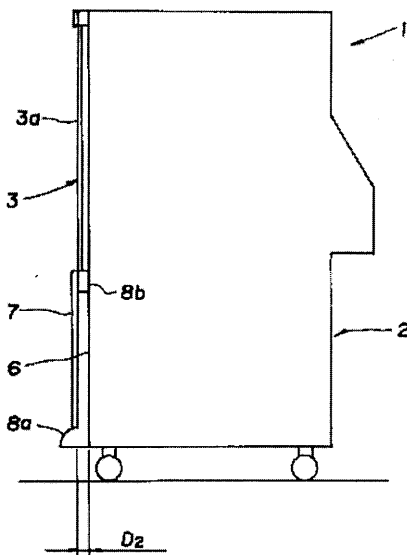

[FIG. 2]

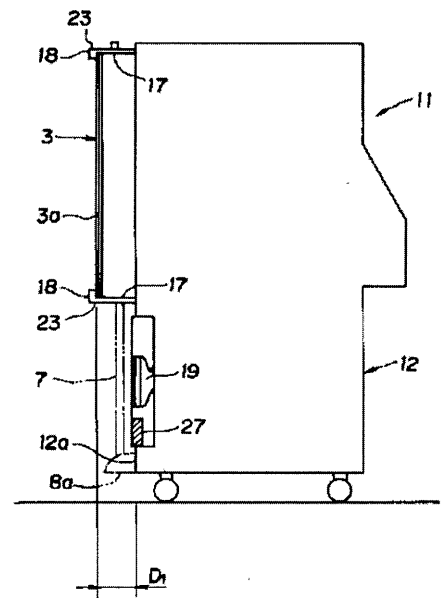

[FIG. 4]

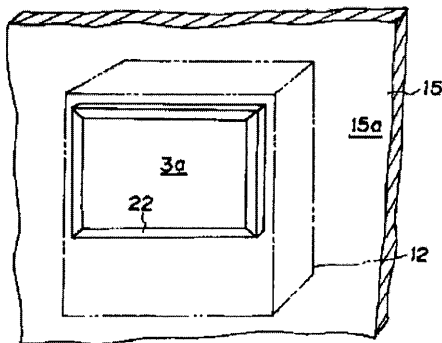

(5)

[FIG. 3]

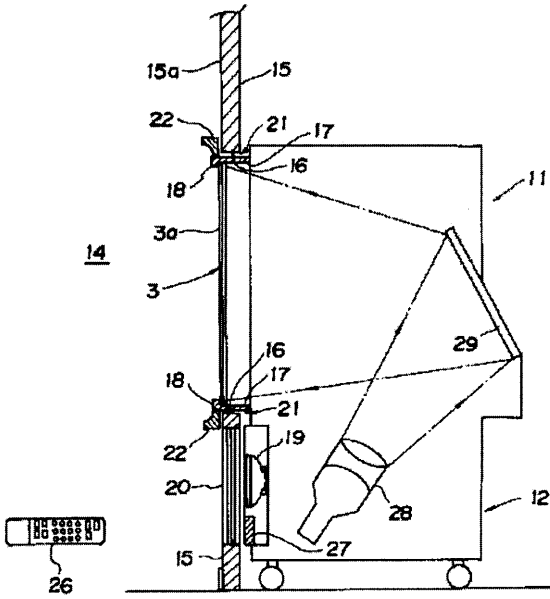

[FIG. 6]

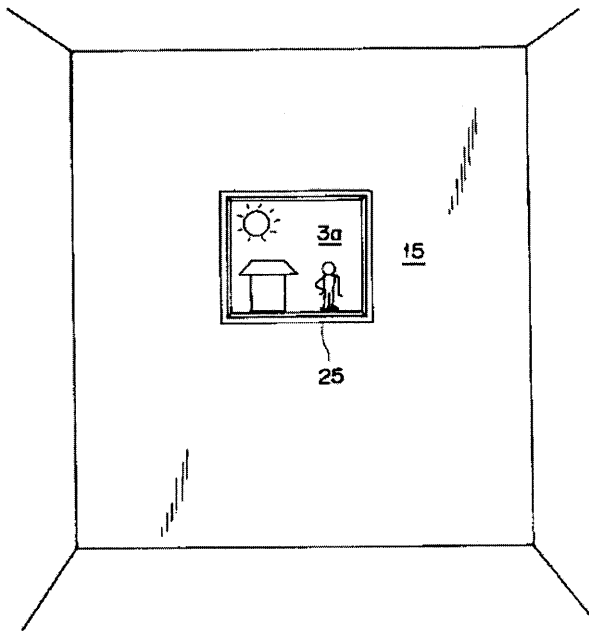

[FIG. 5]

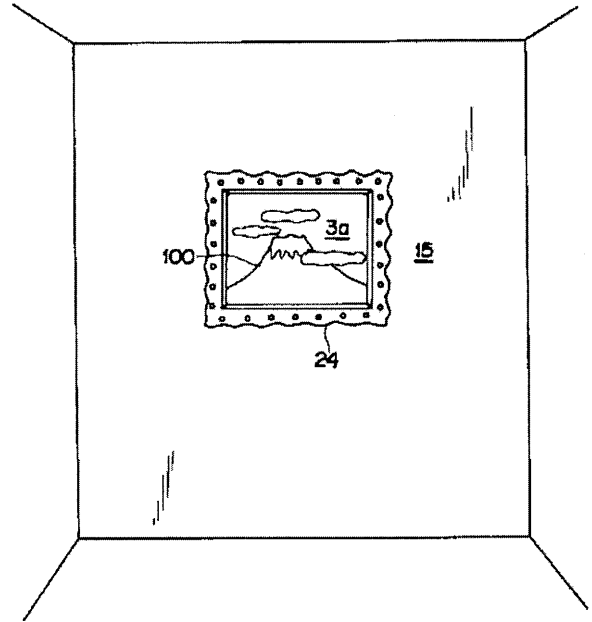

 **Patent Translations Inc.**

1700 Seventh Avenue, Suite 2100 mail@PatentTranslations.com
Seattle, WA 98101, USA http://www.PatentTranslations.com
Fax: 206-299-3692 Tel: 206-357-8508

Certification of Translation

Translator's Declaration: June 21, 2016

I, Martin Cross, hereby declare:

That I possess advanced knowledge of the Japanese and English languages. My qualifications are as follows:

- over 25 years as a Japanese-English translator focusing primarily on patents, and technical and scientific documents;
- co-author of the *Japanese Patent Translator's Handbook*, published by American Translators Association;
- United States district court recognition as an expert in Japanese technical translation for patent litigation; and
- work experience including design and testing of electronic circuits for Research and Development Laboratories Waterloo Ltd.

The attached translation is, to the best of my knowledge and belief, a true and accurate translation from Japanese to English of Japanese Unexamined Patent Application Number JP-04-322579-A. I understand that willful false statements and the like are punishable by fine or imprisonment, or both (18 U.S.C. 1001), and may jeopardize the validity of the application or any patent issuing thereon. I declare under penalty of perjury that all statements made herein of my own knowledge are true, and all statements made on information and belief are believed to be true.

Martin Cross

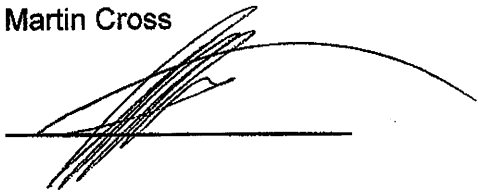

(19) Japanese Patent Office (JP)

(11) Laid Open Patent
Application No.

(12) Kokai Unexamined Patent Application Bulletin (A)

4-160991

(51) Int. Cl.⁵

Identification Code

Internal File No.

(43) Publication Date

H 04 N 7/08
9/00A
C8838-5C
7033-5C

June 4, 1992

Examination
Requestnot yet
madeNumber of
Claims

1

Number of Page

9

(54) Title of the Invention:	Teletext Broadcast Receiving System for Mobile Body		
(21) Application No.:	2-288142		
(22) Application Date:	October 25, 1990		
(72) Inventor:	MAEKAWA, Yoshio	East Japan Railway Co., 1-6-5 Marunouchi, Chiyoda-ku, Tokyo-to	
(72) Inventor:	KAJITA, Toru	East Japan Railway Co., 1-6-5 Marunouchi, Chiyoda-ku, Tokyo-to	
(72) Inventor:	TADAMA, Mare	Sony Co., 6-7-35 Kitashinagawa, Shinagawa-ku, Tokyo-to	
(72) Inventor:	SATO, Fumihisa	Sony Co., 6-7-35 Kitashinagawa, Shinagawa-ku, Tokyo-to	
(71) Applicant:	East Japan Railway Co.	1-6-5 Marunouchi, Chiyoda-ku, Tokyo-to	
(71) Applicant:	Sony Co.	6-7-35 Kitashinagawa, Shinagawa-ku, Tokyo-to	
(74) Agent:	Patent Attorney MATSUZUMI, Hidemori		

Continued on the last page

SPECIFICATION

Title of the Invention: Teletext broadcast receiving system for mobile body

Claim

A teletext broadcast receiving system for a mobile body comprising, installed in a mobile body: a tuner for receiving television broadcasts; a teletext broadcast decoder that extracts and demodulates teletext data from a television broadcast signal received by said tuner; a memory that stores a plurality of frames' worth of the teletext data obtained by said teletext broadcast decoder; and a display means that displays the teletext broadcast data stored in said memory,

configured such that, when at least one frame's worth of teletext broadcast data for a required teletext broadcast program has been demodulated by said teletext broadcast decoder, this frame of teletext broadcast data obtained by demodulation is stored in the corresponding area of said memory and the stored data of said memory is updated.

Detailed Description of the Invention**[Field of Application in Industry]**

The present invention relates to a teletext broadcast receiving system for a mobile body, preferably used in installations in mobile bodies such as electric trains.

[Summary of the Invention]

The present invention is a teletext broadcast receiving system for a mobile body that is installed in a mobile body such as an electric train, configured such that, when at least one frame's worth of teletext broadcast data for a required teletext broadcast program is demodulated by a teletext broadcast decoder, this frame of teletext broadcast data that has been obtained by demodulation is stored in a corresponding area of a memory, the stored data in the memory that stores the teletext broadcast data is updated, and thus, even when all of the data for the teletext broadcast program has not been received, good display of the teletext broadcast program is possible.

[Prior Art]

In recent years, services have been provided to passengers, in which television receivers have been installed in mobile bodies such as electric trains, and images that were played back by VTRs or the like have been received by these. In such cases, an antenna is attached to the roof of the electric train, television broadcast signals are received from ground-based transmitting stations by this antenna,

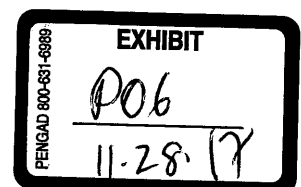

JP-04-160991-A (2)

and images are received.

[Problems to be Solved by the Invention]

However, the ability to receive such television broadcast signals has been limited to times when locations with comparatively good radio wave conditions are traveled through. In other words, with mobile bodies traveling through areas with many obstacles such as buildings, as in cities, there are few locations where good reception is possible without undue interference with the broadcast signals from the transmitting stations, and thus reception status was very poor when a normal television antenna was just installed on a mobile body, such that the images were often in a state that was not good enough for practical use. For example, in the case of the Yamanote electric train line that runs roughly through the center of Tokyo, the distance from the transmitting stations is very short, and it is inherently an area with strong electric fields allowing for good reception, even with a simply structured antenna; but as there are very many obstacles such as buildings, it was nearly impossible to receive television signals with conventional technology without ghosting.

In addition, radio waves for teletext broadcasts were transmitted using a portion of the television broadcast signal, but since these signals for teletext broadcasts were converted into digital data for transmission, it was impossible to receive the teletext broadcasts in moving bodies which are particularly sensitive to occurrences of ghosting.

It is an object of the present invention to make good reception of teletext broadcasts possible in moving bodies such as electric trains.

[Means for Solving the Problems]

As is shown, for example, in Fig. 1, the present invention comprises, installed in a mobile body (1): a tuner for receiving television broadcasts (43); a teletext broadcast decoder (46) that demodulates teletext broadcast data extracted from a television broadcast signal received by this tuner (43); a memory (47) that stores a plurality of frame's worth of the teletext broadcast data obtained by this teletext broadcast decoder (46); and display means (101), (102), (103) ... (124) that display that teletext broadcast data stored in this memory (47), configured such that when at least one frame's worth of teletext broadcast data for a required teletext broadcast program has been decoded by the teletext broadcast decoder (46), this teletext broadcast data that has been obtained by decoding is stored in a corresponding area of the memory (47) and the stored data in the memory (47) is updated.

[Operation]

With this configuration, if the data for all the

frames of the required teletext broadcast program is initially stored in the memory, the data for the teletext broadcast program may be successively updated to the latest version, even if only the data for some of the frames of this teletext broadcast program can be received while the mobile body is traveling or the like, by updating only that portion of the data that could be received to the latest data; and because the data for all of the frames for the required teletext broadcast program is stored in the memory, display of all frames of the teletext broadcast program in question is always possible.

[Embodiment]

In the following, an embodiment of the present invention will be described with reference to Fig. 1 through Fig. 4.

In this example, a television receiver installed in an electric train is used in a receiving system that displays teletext broadcasts; therefore, the overall constitution of this receiving system will be described first.

In Fig. 1 and Fig. 2, (1) indicates a car body for an electric train; doors (entrances and exits) (11), (12), (13) ... (16) and (17), (18), (19) ... (22) are provided in six locations on each side, in the sides of this car body (1); and television receivers (101), (102), (103) ... (124) are installed above the left and right door pocket parts for each of the doors (11) through (22) inside the car. As is shown in Fig. 2, for example, television receivers (117) and (118) are attached to the upper part of the door pocket part on the left and right of the door (19). In this instance, the television receivers (101), (102), (103) ... (124) are thin, using liquid crystal panels or the like.

Furthermore, these television receivers (101), (102), (103) ... (124) display teletext broadcasts, and in order to receive these teletext broadcasts, four antennas (30a), (30b), (30c), (30d) are attached to the periphery of ventilators (3) and (4) on the rooftop (2) of the car body (1). In this instance, each of the antennas (30a), (30b), (30c), (30d)

JP-04-160991-A (3)

has a dipole antenna configuration, comprising two conductor rods (31), (32), the ends of which are proximal, and a reflector (33) disposed with a prescribed gap from these conductor rods (31), (32); the gap part between the two conductor rods (31), (32) is connected to a coaxial cable (35) (see Fig. 3) via a balun (matching transformer), and this coaxial cable (35) is connected to a switch (41) inside an under-floor unit (40), which is described below. The length of the two conductor rods (31), (32) is selected according to the frequency of the channel received, and the reflector (33) is longer than the length of the two conductive rods (31), (32) together.

Furthermore, the mounting angles of the four antennas (30a), (30b), (30c), (30d) are offset 90° each in the horizontal direction; the antennas (30a), (30b) are mounted on the front and back (direction parallel to the rails) of the ventilator (3), and the antennas (30c), (30d) are attached to the left and right (direction perpendicular to the rails) of the ventilator (4) which is adjacent to the ventilator (3).

Describing the manner in which the antennas are mounted on the ventilators in detail here, a plurality of ventilators (3), (4), (5) ... are mounted on the roof (2) of this car body (1); these ventilators (3), (4), (5) ... are so-called forced ventilators that function as ventilation devices forcing air into the car from the outside while it is traveling, and legs (3a), (4a), (5a) at the four corners of each of the ventilators (3), (4), (5) ... are secured to the rooftop (2) by bolts (23). In this instance, each of the ventilators (3), (4), (5) ... is mounted on the car body (1) in an insulated state.

Furthermore, two antennas (30a), (30b) are mounted using the bolts (23) that secure the legs (3a) at the four corners of the ventilator (3). In addition, two antennas (30c), (30d) are mounted using the bolts (23) that secure the legs (4a) at the four corners of the ventilator (4) which is adjacent to the ventilator (3).

Showing enlargements of the situation in which these antennas (30c), (30d) are mounted on the ventilator (4) in Fig. 3 and Fig. 4, a square-U shaped cover (24) is mounted around the ventilator (4) by way of the bolts (23). In this instance, the cover (24) is configured so that it does not block the air passage part (4b) of the ventilator (4). Furthermore, one end of linking members (34) comprised by the antennas (30c) and (30d) is secured to the top part of this cover (24), and along with each of these linking members (34) securing a reflector (33) substantially in the middle, the conductor rods (31), (32) are secured to the other end. Here, the two conductive rods (31) and (32) are secured to the linking member (34) with a prescribed gap. In addition, an insulating material is used for the linking members (34). In addition, in this example, angle materials with L-shaped cross-sections are used for the conductive rods (31), (32)

and reflectors (33), and are configured so that they may easily be mounted.

Here, a space H, in the height direction, between the upper part of each ventilator and the lower edge of the reflector (33) is set to at least 15 mm, and a width L, in the horizontal direction, between each ventilator and the reflector (33) is set to a width of at least 20 mm; furthermore, the reflector height B is set to 70 mm or greater. In this instance, larger values for the height H and width L of the ventilator and the height B of the reflector (33) itself are preferable in terms of the antenna characteristics, but the size of equipment that can actually be installed on the rooftop (2) is determined by standards such as rolling stock gauge, such that very large antennas cannot be mounted, and this is limited to the values described above or values somewhat larger than these values.

With the four antennas (30a), (30b), (30c), (30d) mounted in this manner, each of the antennas (30a), (30b), (30c), (30d) only receives radio waves in the direction in which the conductor rods (31), (32) are disposed; radio waves oriented toward the conductor rods (31), (32) from the opposite side (ventilator side) are blocked by the reflector (33), so that the occurrence of standing waves due to reflected radio waves can be suppressed. Therefore, radio waves that come from all directions in substantially 360° may be received by the four antennas (30a), (30b), (30c), (30d), which are installed in positions that each differ by 90°.

Furthermore, the four antennas (30a), (30b), (30c), (30d) configured in this manner are connected by the coaxial cables (35) to the switch (41) inside the under-floor unit (40) that is hung beneath the floor of the car body (1). The equipment for receiving teletext broadcasts is housed in this under-floor unit (40), and the switch (41) selectively outputs received signals supplied by any of the antennas under the control of a discriminator circuit (44), which will be discussed below.

JP-04-160991-A (4)

Furthermore, this switch (41) supplies the received signal that is output to a ghost reduction tuner (43) via a booster (42), and this ghost reduction tuner (43) receives a television broadcast signal for a prescribed channel that is set in advance. In this instance, the ghost reduction tuner (43) uses a GCR signal that has been inserted into the vertical blanking interval to perform ghost reduction on the received broadcast signal; in addition to channel tuning unit and an intermediate frequency amplifier/demodulator unit, this is provided with a ghost suppression filter, GCR signal extraction circuit, comparator circuit, control circuit and the like; the GCR signal, in which distortion occurs due to irregular reflection of radio waves and the like, and a reference signal are compared, so as to suppress reflected wave signals.

Here, in this example, the television broadcast signal for the prescribed channel obtained by this ghost reduction tuner (43) is supplied to the discriminator circuit (44), and the level of the synchronization signal included in the television broadcast signal received by this discriminator circuit (44) is determined; selection of the antenna line by the switch (41) obtains the synchronization signal with the best level, so as to constitute what is known as antenna diversity. In this instance, a timer circuit (45) is connected to this discriminator circuit (44), and the level discrimination described above is carried out in at prescribed intervals with control by the timer circuit (45).

Furthermore, the television broadcast signal obtained by the ghost reduction tuner (43) is supplied to the teletext broadcast decoder (46), and a teletext broadcast signal of text, graphics and the like that was multiplexed in the vertical blanking interval of the broadcast signal is obtained by this teletext broadcast decoder (46). In this instance, a plurality of teletext broadcast programs are sent in a single channel of television broadcast signal, and when at least one frame's worth of data for a prescribed teletext broadcast program that was set in advance has been obtained, this data is recorded in the memory (47) connected to the teletext broadcast decoder (46). In other words, the teletext broadcast decoder (46) has a circuit that determines whether or not each teletext broadcast frame that is received and obtained is complete; and when it is determined by this circuit that complete frame data for even one frame has been obtained, if this data is from a required teletext broadcast program, it is stored in the memory (47).

Describing the configuration of this memory (47) here, the data storage part of this memory (47) is divided into a plurality of areas, and the areas are used as shown in Fig. 5. In other words, this is configured so that four teletext broadcast programs A, B, C, D may be stored, with areas a1 through a10,

b1 through b10, c1 through c10 and d1 through d10, which can store 10 frame's worth [of data] from page 1 to page 10, for each program. In this instance, areas a1 through a10, b1 through b10, c1 through c10 and d1 through d10 are configured so that, if data for a prescribed teletext broadcast program stored is temporarily stored therein when the vehicle (1) starts driving, the stored data for each area can be updated independently; and when it has only been possible to receive some of the pages (frames) of a teletext broadcast program, only the storage areas for these pages that it was possible to receive are overwritten. Therefore, there are instances where the data stored for each page comprised by the teletext broadcast programs A, B, C, D is not stored at the same time. Moreover, when the teletext broadcast programs A, B, C, D are made up of 10 or fewer pages, pages for which data is not obtained are left as empty areas.

Furthermore, the data for the prescribed teletext broadcast program stored in the memory (47) in this manner is sequentially read out to the teletext broadcast decoder (46) and made into a video signal for displaying the text, graphics and the like as images, this video signal being output from the under-floor unit (40) via a coaxial cable. When, in this instance, at least one frame's worth of any program of the four stored teletext broadcast programs A, B, C, D is overwritten, this overwritten program is read sequentially from the first page to the final page and is displayed.

Moreover, the output video signal from the under-floor unit (40) is a baseband video signal (in other words a video signal that is not RF modulated). In this example, in addition, a power supply circuit (48) is provided in the under-floor unit (40), and a low voltage DC power supply is output from this power supply circuit (48).

Furthermore, the coaxial cable that outputs the video signal from the under-floor unit (40) is connected to a three-way distributor (61) in the car body (1) to provide the output video signal. In addition,

JP-04-160991-A (5)

the power supply output from the power supply circuit (48) is also supplied to the three-way distributor (61). This three-way distributor (61) is configured so that the baseband video signal is distributed three ways.

Furthermore, of the first second and third distribution outputs from this three-way distributor (61), the first distribution output is supplied to a first two-way distributor (71), the second distribution output is supplied to a connection terminal (62) provided on a connection surface on a first end (one end) of the car body (1) and the third distribution output is supplied to a connection terminal (63) provided on a connection surface on a second end (other end) of the car body (1). In addition, the power supply supplied to the three-way distributor (61) is also supplied to the first two-way distributor (71).

This first two-way distributor (71) is configured so that the baseband video signal that is supplied is distributed two ways.

Furthermore, the first distribution output distributed by the first two-way distributor (71) is supplied to a second two-way distributor (72) connected to a subsequent stage, and the second distribution output is supplied to a 13th two-way distributor (83) that is connected to a subsequent stage. In this instance, the power supply supplied from the three-way distributor (61) side is supplied to the second and 13th two-way distributors (72) and (83).

This second two-way distributor (72) is configured so as to perform two-way distribution in the same manner as the first two-way distributor (71), and the first distribution output is supplied to a television receiver (102) mounted inside the car, while the second distribution output is connected to a third two-way distributor (73).

Hereafter, the baseband video signal supplied by the two-way distributors (73), (74), (75) ... (82) connected to the subsequent stage is distributed in two in the same manner, and the first distribution outputs are supplied to the corresponding television receivers (103), (104), (105) ... (111) mounted inside the car, while the second distribution outputs are supplied to the two-way distributors (74), (75), (76) ... (82) connected to the subsequent stage. However, the second distribution output of the 12th two-way distributor (82) connected at the end is supplied to a television receiver (112).

In this instance, the power supply supplied from the two-way distributor in the previous stage is supplied to television receivers connected to the various two-way distributors and the two-way distributor in the subsequent stage.

In addition, the first distribution output of the 13th two-way distributor (83) connected to the second distribution output side of the first two-way distributor (71) is supplied to a television receiver

(113) mounted inside the car, while the second distribution output is supplied to a 14th two-way distributor (84) in the subsequent stage.

Hereafter, the baseband video signal supplied by two-way distributors (84), (85), (86) ... (93) connected to subsequent stage is distributed in two in the same manner, and the first distribution outputs are supplied to the corresponding television receivers (114), (115), (116) ... (124) mounted inside the car, while the second distribution outputs are supplied to two-way distributors (85), (86), (87) ... (93) connected to the subsequent stage. However, the second distribution output of the 23rd two-way distributor (93) connected at the end is supplied to a television receiver (124).

In this instance as well, the power supply supplied from the two-way distributor in the previous stage is supplied to television receivers connected to the various two-way distributors and the two-way distributor in the subsequent stage.

Moreover, when the connection terminals (62) and (63) provided on the connection surface are linked to other preceding and following cars, which are not provided with tuners or the like, they are connected to video signal input terminals in these connected cars (not shown in the drawings). The video signals for the teletext broadcasts and the like may be supplied to preceding and following cars. In this instance, the power supply necessary for the television receivers in the preceding and following cars is supplied by a power supply circuit in each of the cars.

Next, the operation when teletext broadcast images are displayed on the television receivers (101), (102), (103) ... (124) connected in this manner will be described.

First, the teletext broadcast is received, and the data for the required teletext broadcast program is stored in the memory (47) connected to the teletext broadcast decoder (46). If, in this instance, the television broadcast signal reception status is good, the operation of storing this to the memory (47) will be completed in a short time, but because the service is provided when the vehicle (1) actually is traveling, if at least one frame's worth of data for a required teletext broadcast program can be obtained by the teletext broadcast decoder (46), when the reception status is temporarily good, this obtained frame data is stored in the memory (47), and the data in the same page, which was stored previously, is updated with the data that was newly received.

In other words, as is shown in the flow chart in Fig. 6,

the frame of the teletext broadcast program received by the teletext broadcast decoder (46) is assembled, and a determination is made as to whether the frame that is assembled is a complete frame (in other words, whether the assembled frame is free of missing parts). Furthermore, if the assembled frame is complete, the data for this frame is written to the corresponding area of the memory (47), and the data in this area is overwritten. Furthermore, when this overwriting has been performed, the data stored in the memory (47) is read out and an output video signal is created by the teletext broadcast decoder (46), so that the teletext broadcast program that has been overwritten is displayed sequentially starting with the first page. In addition, when the assembled frame is determined to be an incomplete frame, the assembled frame data is discarded, and the data received at this time is not stored.

When this teletext broadcast program is received, the direction of the transmitting station as seen from the vehicle (1) changes with travel, but this had been configured for antenna diversity, in which a determination is made as to whether good reception is possible with any of the four antennas (30a), (30b), (30c), (30d), which each differ in direction by 90°; the tuner (43) is connected, by the switch (41), to each of these antennas (30a), (30b), (30c), (30d), in order; the reception status is sequentially determined by the determination circuit (44) in the ghost reduction tuner (43); and the antenna obtaining the best broadcast signal is connected.

Moreover, since having a temporarily good reception status and obtaining a frame of a required teletext broadcast program with the teletext broadcast decoder (46) is limited to very good reception statuses, most [reception] will be when stopped at stations or the like. In other words, for example, in the case of an electric train traveling as a local train in the city center, it will stop for a few tens of seconds to one minute at a station in every two to three minutes of travel; and there is a high probability that reception of a teletext broadcast program will be possible during this stop, such that reception of teletext broadcasts will possible relatively frequently. In this case, the time necessary for one frame's worth of one teletext broadcast program to be transmitted is often normally under one second, and at the longest several seconds; therefore, it is fully possible to receive a teletext broadcast program with the configuration described above.

Furthermore, if teletext data can be captured to the memory (47) that is connected to the teletext broadcast decoder (46) in this manner, the data for the teletext broadcast program that is displayed at prescribed intervals is read and a video signal for displaying the teletext broadcast is created; this video signal is transmitted to the television receivers (101) through (124) via the distributors (61), (71)

through (93), and the teletext broadcast program is displayed on the television receivers (101) through (124) disposed in this vehicle. In this instance, the four teletext broadcast programs stored in the memory (47) are displayed sequentially in a cycle of several minutes to several dozen minutes. However, when new teletext broadcast program data has been received, as described above, this program that has been received is displayed starting with the first page.

Moreover, in the embodiment described above, only teletext broadcast receiving equipment was installed, but image playback equipment such as a VTR may be provided, and playback images and the teletext broadcast programs maybe be alternately displayed. In addition, this was configured so that, when data for a teletext broadcast program has been received, this teletext broadcast program is displayed, but the four teletext broadcast programs may be displayed sequentially at prescribed time periods, regardless of the data reception status.

In addition, in the embodiment described above, the receiving system was installed in an electric train, but it may also be used in other mobile bodies (automobiles, ships or the like).

Furthermore, the present invention is also not limited to the embodiment described above and various other configurations are of course possible.

[Effects of the Invention]

According to the present invention, even when only data for some frames of this teletext broadcast program can be received while a mobile body is travelling or the like, only that portion of the data that has been received is updated with the most recent data, so that the data for the teletext broadcast program is successively updated with the most recent data, so that teletext broadcast programs using the most comparatively recent data can always be displayed, even if the reception status in the mobile body deteriorates during travel or the like.

Brief Description of the Drawings

Fig. 1 is a block diagram showing an embodiment of the present invention; Fig. 2 is a partial cutaway perspective view showing the situation in which the system in one embodiment is installed in a car body; Fig. 3 is a perspective view showing the important parts of an embodiment; Fig. 4 is a side view showing the important parts of an embodiment; Fig. 5 is a schematic view showing the manner in which the memory is used in one embodiment; and Fig. 6 is a flow chart to accompany a description of an embodiment.

(1) is a car body; (3), (4) ... (8) are ventilators; (30a), (30b), (30c), (30d) are antennas, (40) is an under-floor unit; (41) is a switch; (43) is ghost reduction tuner; (46) is a teletext broadcast decoder; (47) is a memory; (48) is a power supply circuit; (61) is a three-way distributor; (62), (63) are connection terminals; (71), (72) ... (93) are two-way distributors; and (101), (102) ... (124) are television receivers.

	program A	program B	program C	program D
page 1	a 1	b 1	c 1	d 1
page 2	a 2	b 2	c 2	d 2
page 3	a 3	b 3	c 3	d 3
...
page 10	a10	b10	c10	d10

Example of memory areas
FIG. 5

Agent: MATSUZUMI, Hidemori

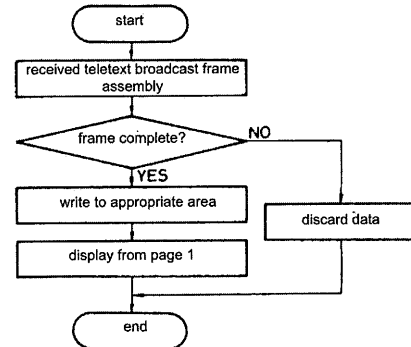

Flowchart for reception of teletext broadcast
FIG. 6

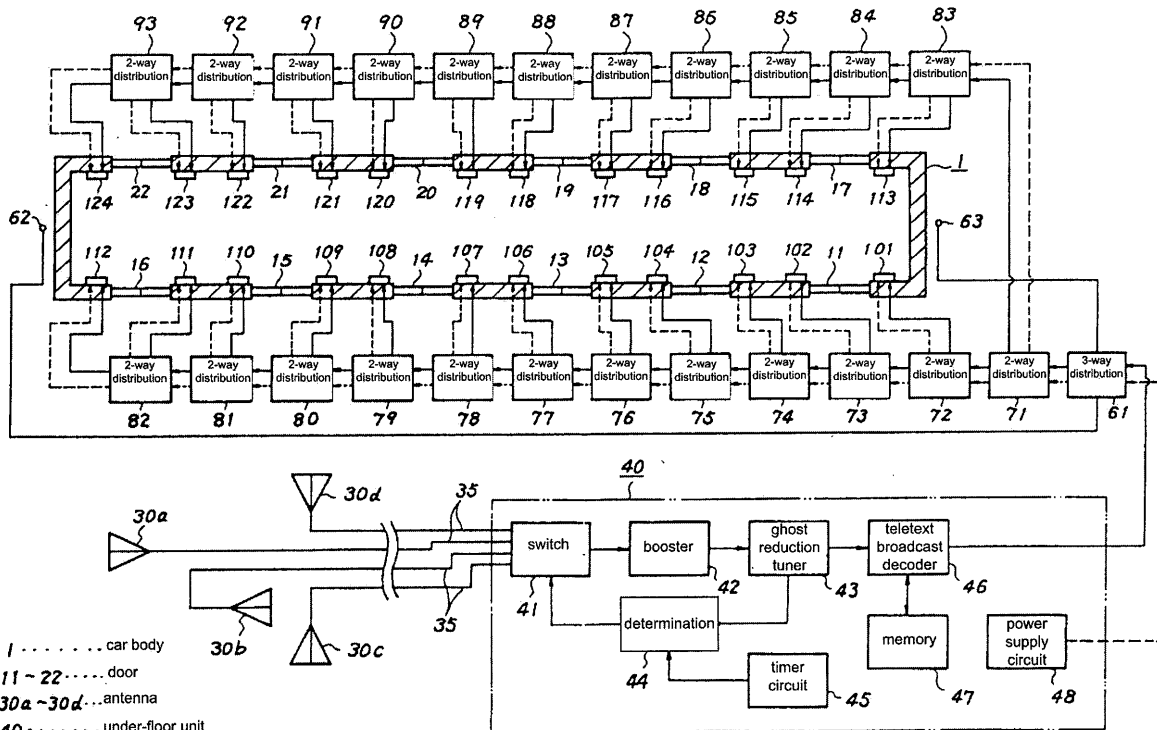

Overall configuration
FIG. 1

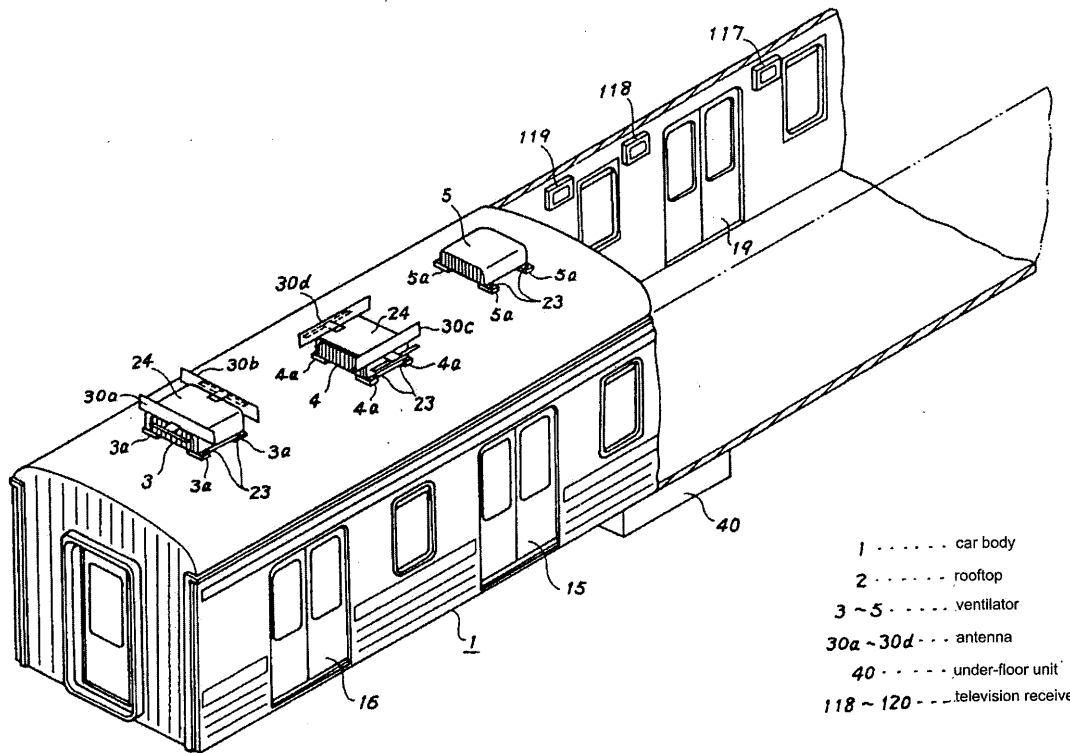

- 1 car body
- 2 rooftop
- 3 ~ 5 ventilator
- 30a ~ 30d antenna
- 40 under-floor unit
- 118 ~ 120 television receiver

Situation when mounted on car body
FIG. 2

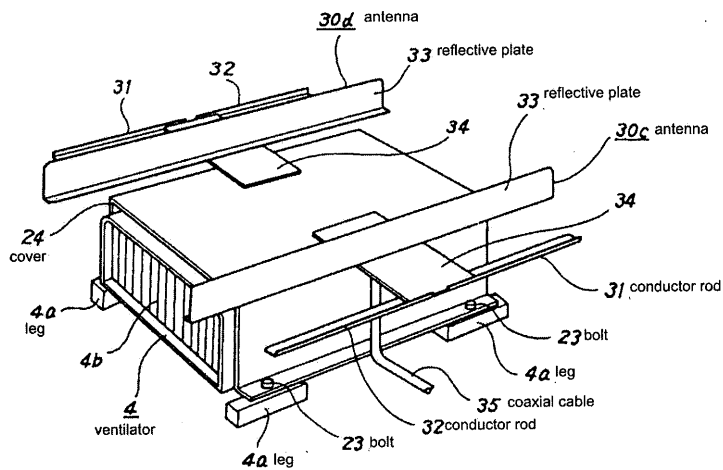

Enlargement of area around antenna
FIG. 3

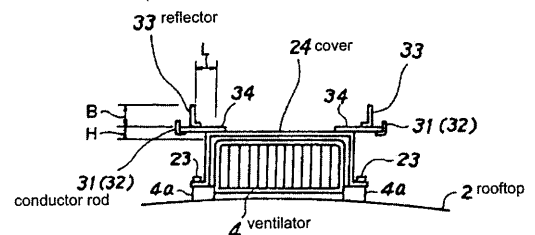

View showing antenna mounting state
FIG. 4

Continued from page 1

(72) Inventor:	KATO, Kenichi	Sony Co., 6-7-35 Kitashinagawa, Shinagawa-ku, Tokyo-to
(72) Inventor:	ARAI, Takehiko	Sony Co., 6-7-35 Kitashinagawa, Shinagawa-ku, Tokyo-to
(72) Inventor:	AOZUKA, Torao	Sony Co., 6-7-35 Kitashinagawa, Shinagawa-ku, Tokyo-to



1700 Seventh Avenue, Suite 2100 mail@PatentTranslations.com
Seattle, WA 98101, USA http://www.PatentTranslations.com
Fax: 206-299-3692 Tel: 206-357-8508

Certification of Translation

Translator's Declaration: September 8, 2016

I, Martin Cross, hereby declare:

That I possess advanced knowledge of the Japanese and English languages. My qualifications are as follows:

- over 25 years as a Japanese-English translator focusing primarily on patents, and technical and scientific documents;
- co-author of the *Japanese Patent Translator's Handbook*, published by American Translators Association;
- United States district court recognition as an expert in Japanese technical translation for patent litigation; and
- work experience including design and testing of electronic circuits for Research and Development Laboratories Waterloo Ltd.

The attached translation is, to the best of my knowledge and belief, a true and accurate translation from Japanese to English of Japanese Unexamined Patent Application Number JP-04-160991-A. I understand that willful false statements and the like are punishable by fine or imprisonment, or both (18 U.S.C. 1001), and may jeopardize the validity of the application or any patent issuing thereon. I declare under penalty of perjury that all statements made herein of my own knowledge are true, and all statements made on information and belief are believed to be true.

Martin Cross

A handwritten signature in black ink, consisting of several overlapping, sweeping strokes, positioned above a horizontal line.



49728

Federal Register / Vol. 62, No. 184 / Tuesday, September 23, 1997 / Proposed Rules

EXHIBIT
PO7
11-28-17

FENGAD 800-631-8688

DEPARTMENT OF TRANSPORTATION**Federal Railroad Administration****49 CFR Parts 216, 223, 229, 231, 232, and 238****[FRA Docket No. PCSS-1, Notice No. 2]****RIN 2130-AA95****Passenger Equipment Safety Standards****AGENCY:** Federal Railroad Administration (FRA), Department of Transportation (DOT).**ACTION:** Notice of proposed rulemaking (NPRM).

SUMMARY: FRA is proposing a rule establishing comprehensive Federal safety standards for railroad passenger equipment. The proposed rule contains requirements concerning equipment design and performance criteria related to passenger and crew survivability in the event of a passenger train accident; the inspection, testing, and maintenance of passenger equipment; and the safe operation of passenger train service. The proposed rule is designed to address the safety of passenger train service in an environment where technology is advancing, and equipment is being designed for operation at higher speeds. The rule would amend existing regulations concerning special notice for repairs, safety glazing, locomotive safety, safety appliances, and railroad power brakes as applied to passenger equipment.

The proposed rule does not apply to tourist and historic railroad operations. However, after consulting with the excursion railroad associations to determine appropriate applicability in light of financial, operational, or other factors unique to such operations, FRA may prescribe requirements for these operations that are different from those affecting other types of passenger operations.

DATES: (1) *Written comments:* Written comments must be received on or before November 24, 1997. Comments received after that date will be considered by FRA and the Passenger Equipment Safety Standards Working Group to the extent possible without incurring substantial additional expense or delay. The docket will remain open until the Working Group proceedings are concluded. Requests for formal extension of the comment period must be made by November 7, 1997.

(2) *Public hearing:* FRA intends to hold a public hearing to allow interested parties the opportunity to comment on specific issues addressed in the NPRM.

The date and location of the hearing will be set forth in a forthcoming notice that will be published in the *Federal Register*. Anyone who desires to make an oral statement at the hearing must notify the Docket Clerk by telephone (202-632-3198), and must submit three copies of the oral statement that he or she intends to make at the hearing. The notification should also provide the Docket Clerk with the participant's mailing address. FRA reserves the right to limit participation in the hearings of persons who fail to provide such notification. The date by which the Docket Clerk must be notified about the oral statement and receive copies of it will be set forth in the notice announcing the hearing.

ADDRESSES: Written comments should identify the docket number and must be submitted in triplicate to the Docket Clerk, Office of Chief Counsel, Federal Railroad Administration, 400 Seventh Street, S.W., Mail Stop 10, Washington, D.C. 20590. Persons desiring to be notified that their comments have been received by FRA should submit a stamped, self-addressed postcard with their comments. The Docket Clerk will indicate on the postcard the date on which the comments were received and will return the card to the addressee. Written comments will be available for examination, both before and after the closing date for written comments, during regular business hours in Room 7051 of FRA headquarters at 1120 Vermont Avenue, N.W., in Washington, D.C.

FOR FURTHER INFORMATION CONTACT: Edward Pritchard, Acting Staff Director, Motive Power and Equipment Division, Office of Safety Assurance and Compliance, FRA, 400 Seventh Street, S.W., Mail Stop 25, Washington, D.C. 20590 (telephone: 202-632-3362); Daniel Alpert, Trial Attorney, Office of Chief Counsel, FRA, 400 Seventh Street, S.W., Mail Stop 10, Washington, D.C. (telephone: 202-632-3186); or Thomas Herrmann, Trial Attorney, Office of Chief Counsel, FRA, 400 Seventh Street, S.W., Mail Stop 10, Washington, D.C. 20590 (telephone: 202-632-3167).

SUPPLEMENTARY INFORMATION:**Background**

To enhance rail safety, the Secretary of Transportation convened a meeting of representatives from all sectors of the rail industry in September, 1994. As one of the initiatives arising from this Rail Safety Summit, the Secretary announced that DOT would begin developing safety standards for rail passenger equipment over a five-year period. In November, 1994, Congress

adopted the Secretary's schedule for implementing rail passenger equipment regulations and included it in the Federal Railroad Safety Authorization Act of 1994 (the Act), Pub. L. No. 103-440, 108 Stat. 4619, 4623-4624 (November 2, 1994). Section 215 of the Act, as now codified at 49 U.S.C. 20133, requires:

(a) **MINIMUM STANDARDS.**—The Secretary of Transportation shall prescribe regulations establishing minimum standards for the safety of cars used by railroad carriers to transport passengers. Before prescribing such regulations, the Secretary shall consider—

- (1) The crashworthiness of the cars;
- (2) Interior features (including luggage restraints, seat belts, and exposed surfaces) that may affect passenger safety;
- (3) Maintenance and inspection of the cars;
- (4) Emergency response procedures and equipment; and
- (5) Any operating rules and conditions that directly affect safety not otherwise governed by regulations.

The Secretary may make applicable some or all of the standards established under this subsection to cars existing at the time the regulations are prescribed, as well as to new cars, and the Secretary shall explain in the rulemaking document the basis for making such standards applicable to existing cars.

(b) **INITIAL AND FINAL REGULATIONS.**—(1) The Secretary shall prescribe initial regulations under subsection (a) within 3 years after the date of enactment of the Federal Railroad Safety Authorization Act of 1994. The initial regulations may exempt equipment used by tourist, historic, scenic, and excursion railroad carriers to transport passengers.

(2) The Secretary shall prescribe final regulations under subsection (a) within 5 years after such date of enactment.

(c) **PERSONNEL.**—The Secretary may establish within the Department of Transportation 2 additional full-time equivalent positions beyond the number permitted under existing law to assist with the drafting, prescribing, and implementation of regulations under this section.

(d) **CONSULTATION.**—In prescribing regulations, issuing orders, and making amendments under this section, the Secretary may consult with Amtrak, public authorities operating railroad passenger service, other railroad carriers transporting passengers, organizations of passengers, and organizations of employees. A consultation is not subject to the Federal Advisory Committee Act (5 U.S.C. App.), but minutes of the consultation shall be placed in the public docket of the regulatory proceeding.

The Secretary of Transportation has delegated these rulemaking responsibilities to the Federal Railroad Administrator. 49 CFR 1.49(m).

Consistent with the intent of Congress that FRA consult with the railroad industry in prescribing these regulations, FRA invited various organizations to participate in a working

group to focus on the issues related to railroad passenger equipment safety and assist FRA in developing Federal safety standards. The Passenger Equipment Safety Standards Working Group (or the "Working Group") first met on June 7, 1995,¹ and continues to meet in support of this rulemaking. This proposed rule was developed by FRA in consultation with the Working Group, and FRA will again convene the Working Group to consider comments received in response to this Notice and develop the final rule. Notice of any Working Group meetings will be available through the FRA Docket Clerk.

The Working Group has evolved since its initial meeting, and its membership currently includes representatives from the following organizations:

American Association of Private Railroad Car Owners, Inc. (AAPRCO),
American Association of State Highway and Transportation Officials (AASHTO),
American Public Transit Association (APTA),
Association of American Railroads (AAR),
Brotherhood of Locomotive Engineers (BLE),
Brotherhood Railway Carmen (BRC),
FRA,
Federal Transit Administration (FTA) of DOT,
National Railroad Passenger Corporation (Amtrak),
National Association of Railroad Passengers (NARP),
Railway Progress Institute (RPI),
Safe Travel America (STA),
Transportation Workers Union of America (TWU), and
United Transportation Union (UTU).

The Working Group is chaired by FRA, and supported by FRA program, legal, and research staff, including technical personnel from the Volpe National Transportation Systems Center (Volpe Center) of the Research and Special Programs Administration of DOT. FRA has included vendor representatives designated by RPI as associate members of the Working Group. FRA has also included the AAPRCO as an associate Working Group member. The National Transportation Safety Board has designated staff members to advise the Working Group.

In developing proposed safety standards for passenger equipment operating at speeds greater than 125 mph but not exceeding 150 mph, FRA formed a subgroup (the "Tier II Equipment Subgroup") of Working Group members representing interests associated with the provision of rail passenger service at such high speeds. FRA invited representatives from organizations including Amtrak, the

BLE, BRC, RPI, and UTU to participate in this effort.

In accordance with 49 U.S.C. 20133(d), the evolving positions of the Working Group members—as reflected in the minutes of the group's meetings and associated documentation, together with data provided by the members during their deliberations—have been placed in the public docket of this rulemaking.

On June 17, 1996, FRA published an Advance Notice of Proposed Rulemaking (ANPRM) concerning the establishment of comprehensive safety standards for railroad passenger equipment (61 FR 30672). The ANPRM provided background information on the need for such standards, offered preliminary ideas on approaching passenger safety issues, and presented questions on various topics including: system safety programs and plans; passenger equipment crashworthiness; inspection, testing, and maintenance requirements; training and qualification requirements for mechanical personnel and train crews; excursion, tourist, and private equipment; commuter equipment and operations; train make-up and operating speed; tiered safety standards; fire safety; and operating practices and procedures.

FRA's commitment to developing proposed regulations through the Working Group necessarily influenced the role and purpose of the ANPRM. FRA specifically asked that members of the Working Group not respond formally to the ANPRM. The issues and ideas presented in the ANPRM had already been placed before the Working Group, and the Working Group had commented on drafts of the ANPRM. As a result, FRA solicited the submission of written comments that might be of assistance in developing a proposed rule from interested persons not involved in the Working Group's deliberations.

FRA received 12 comments in response to the ANPRM, including a request from a member of the Working Group to extend the ANPRM's comment period. In addition, the United States Small Business Administration (SBA) commented that the length of the comment period was inadequate for the industry, especially small railways, to prepare a thorough response to the ANPRM. FRA had closed the comment period on July 9, 1996, so that all comments could be shared with the Working Group before its meeting on July 10, 1996.

Although FRA did not formally extend the comment period, comments received after the closing date of the comment period have been shared with the Working Group at subsequent

meetings. Such comments have been considered (and identified in this Notice) to the extent possible without incurring additional delay in preparing this Notice. Moreover, the Working Group is broadly representative of interests involved in the provision of intercity and commuter rail service nationwide, and its members had the opportunity to comment on the issues raised in the ANPRM before the document's publication, as noted above.

Need for Safety Standards

Effective Federal safety standards for freight equipment have long been in place, but equivalent Federal standards for passenger equipment do not currently exist. The AAR sets industry standards for the design and maintenance of freight equipment that add materially to the safe operation of this equipment. Industry standards for the safety of railroad passenger equipment have been in place since the early part of this century, as noted by the AAPRCO in comment on the ANPRM. However, over the years, the AAR has discontinued the development and maintenance of passenger equipment standards.

Passenger railroads do offer the traveling public one of the safest forms of transportation available. In the five-year period 1991–1995, there were 1.07 passenger fatalities for every billion miles a passenger was transported by rail. However, accidents continue to occur, often as a result of factors beyond the control of the passenger railroad. Further, the rail passenger environment is rapidly changing. Worldwide, passenger equipment operating speeds are increasing. Several passenger trainsets designed to European standards have been proposed for operation at high speeds in the United States. In general, these trainsets do not meet the structural or operating standards that are common practice for current North American equipment. FRA believes that adherence to such standards by the nation's passenger railroads has in large measure contributed to the high level of safety at which rail passenger service is currently operated. However, these standards do not have the force of regulation.

In general, the North American railroad operating environment requires passenger equipment to operate commingled with very heavy and long freight trains, often over track with frequent grade crossings used by heavy highway equipment. European passenger operations are intermingled with freight equipment of lesser weight than in North America. In many cases, highway-rail grade crossings also pose

¹ This date was incorrectly identified as June 6, 1995, in the Advance Notice of Proposed Rulemaking (61 FR 30672, June 17, 1996).

lesser hazards to passenger trains in Europe due to lower highway vehicle weight. European passenger equipment design standards may therefore not be appropriate for the North American rail environment.

FRA must become more active to ensure that passenger trains continue to be designed, built, and operated with a high level of safety. A clear set of Federal safety and design standards for passenger equipment tailored to the nation's operating environment is needed to provide for the safety of future rail operations and to facilitate sound planning for those operations.

Passenger Train Safety Hazards

Passenger trains are exposed to a variety of safety hazards. Some of these hazards are endemic to the nation's rail passenger operating environment, as noted above, and result from the operation of passenger trains commingled with freight trains, often over track with frequent grade crossings used by heavy highway equipment.

Collisions with a wide range of objects may occur at various speeds under a number of different circumstances. In addition to freight trains and highway vehicles, these objects include maintenance-of-way equipment and other passenger trains. Although most of these collisions occur only in the normal running direction of the train, impact into the side of the train can occur, especially at the junction of rail lines and at highway-rail grade crossings.

A passenger train collision with another train concerns FRA because of the potential for significant harm demonstrated in actual accidents.

- On February 16, 1996, a near-head-on collision occurred between Maryland Rail Commuter Service (MARC) train 286 and Amtrak train 29 on track owned by CSX Transportation, Inc., (CSXT) at Silver Spring, Maryland. The MARC train was operating with a cab car (a car which provides passenger seating, as well as a location from which the train is operated) as the lead car in the train, followed by two passenger coaches and a locomotive pushing the consist. The collision separated the left front corner of the cab car from the roof to its sill plate, and tore off much of the forward left side of the car body. Three crewmembers and eight passengers were fatally injured, and 13 other occupants of the MARC train sustained injuries. (FRA Accident Investigation Report (Report) B-3-96.)

- On February 9, 1996, a near-head-on collision occurred between New Jersey Transit Rail Operations, Inc., trains 1254 and 1107 on the borderline

of Secaucus and Jersey City, New Jersey. Two crewmembers and one passenger were fatally injured, and 35 other people sustained injuries. The passenger fatality and most of the nonfatal injuries to passengers occurred on train 1254, which was operating with the cab car forward, followed by four passenger coaches and a locomotive pushing the consist. (FRA Report B-2-96.)

- On January 18, 1993, Northern Indiana Commuter Transportation District (NICTD) trains 7 and 12 collided corner-to-corner in Gary, Indiana. The left front corners and adjacent car body sidewall structures were destroyed on both of the lead cars in each train. Seven passengers died, and 95 people sustained injuries. (NTSB/Railroad Accident Report (RAR)-93/03.)

The exposure of passenger trains to hazards associated with sharing common rights-of-way with freight trains has been demonstrated in recent accidents, and a past disastrous accident.

- On February 15, 1995, an Amtrak train traveling at 58 mph struck a shifted load of steel "I" beams extending from a Union Pacific Railroad Company freight train stopped in a siding at Borah, Idaho. The Amtrak train's six passenger coaches were raked with a steel beam which penetrated the outer layer of the car bodies at various points. Although no passengers were injured, the Amtrak train's two locomotives were significantly damaged, and two crewmembers were injured. (FRA Report C-14-95.)

- On May 16, 1994, an Amtrak train derailed after striking an intermodal trailer which had fallen or was falling from a CSXT freight train travelling northbound on an adjacent track at Selma, North Carolina. The lead locomotive of the Amtrak train rolled over, and the assistant engineer was killed. The engineer sustained serious injuries, and 120 other occupants of the Amtrak train reported injuries. (NTSB/RAR-95/02.)

- On January 4, 1987, an Amtrak train collided with the rear of a Consolidated Rail Corporation (Conrail) train near Chase, Maryland, when it unexpectedly entered the track ahead of the Amtrak train, which had been travelling between 120 and 125 mph only a few seconds earlier. The Amtrak train's two locomotives and three front passenger cars were destroyed in the collision. The engineer and 15 passengers aboard the Amtrak train were fatally injured, and 174 other persons aboard the train were injured. (NTSB/RAR-88/01.)

The exposure of passenger trains to hazards associated with operating over frequent highway-rail grade crossings,

used by heavy highway vehicles, has also been demonstrated in numerous accidents.

- On January 16, 1996, a Massachusetts Bay Transportation Authority (MBTA) train being operated by Amtrak struck a loaded tractor-trailer which had become lodged in a grade crossing in Wakefield, Massachusetts. Twenty-two passengers were taken to hospitals by ambulance or air. (FRA Report C-4-96.)

- On October 3, 1995, a Metro-North Commuter Railroad Company (Metro-North) train with a cab car in the lead struck a loaded tractor-trailer which had become lodged in a grade crossing near Milford, Connecticut. Two crewmembers and 24 passengers were injured. (FRA Report C-60-95.)

- On September 21, 1995, an Amtrak train traveling at 81 mph struck a loaded tractor-trailer at a highway-rail grade crossing near Indiantown, Florida. The assistant engineer was killed, and five other persons onboard the train were injured. (FRA Report C-56-95.)

- On November 30, 1993, an Amtrak train derailed after striking an 82-ton turbine being transported by a 184-foot long vehicle which was fouling a grade crossing near Intercession City, Florida. Fifty-eight of the train's passengers and crewmembers were injured. (NTSB Highway Accident Report 95/01.)

In addition to collisions involving passenger trains striking highway vehicles, highway vehicles may also strike passenger trains. According to FRA's Rail-Highway Grade Crossing Accident/Incident database, 13.8% of all highway-rail grade crossing collisions involving passenger trains from 1986 through 1995 occurred when the highway vehicle struck the passenger train. This accounts for 388 such occurrences out of 2,820 highway-rail grade crossing collisions involving passenger trains in this period. In commenting on the ANPRM, the Washington State Department of Transportation (WSDOT) had asked that FRA clarify the statement that 25 percent of all highway-rail grade crossing accidents involve a highway vehicle striking the side of a train. See 61 FR 30692. Though this higher figure does include accidents involving both freight and passenger trains, the potential for a highway vehicle to strike a passenger train is real.

The WSDOT also requested that FRA document how many "heavy" highway vehicles were involved in highway-rail grade crossing accidents in which highway vehicles struck passenger trains. Over the same ten-year period from 1986 through 1995, 52 of the 388 occurrences in which a highway vehicle

struck a passenger train involved a heavy highway vehicle. For purposes of this analysis, FRA considered the number of heavy highway vehicles which struck passenger trains to consist of all those vehicles identified as a "Truck-Trailer" (12) and one-half the number of those vehicles identified as a "Truck" (79), as specified according to Form FRA F 6180.57—Rail-Highway Grade Crossing Accident/Incident Report.

Passenger trains are also vulnerable to accidents caused by defective railroad track structure and vehicle interaction with the rail structure.

- On August 3, 1994, an Amtrak train derailed while travelling at approximately 79 mph on Conrail trackage near Batavia, New York, because of the dynamic interaction between a material handling car and a flattened rail head. Five of the derailed passenger cars descended a railroad embankment and came to rest on their sides. One-hundred-and-eight passengers and ten crewmembers were injured. (NTSB/RAR-96/02.)

- On July 31, 1991, an Amtrak train derailed while travelling at 80 mph over CSXT trackage in Lugoff, South Carolina, when a switch point leading to a parallel auxiliary track unexpectedly opened under the Amtrak train. The derailed passenger cars collided with the first of nine hopper cars stored on the auxiliary track. The collision caused the wheel set from the first hopper car to penetrate the last passenger car. Eight passengers were fatally injured, and 12 passengers sustained serious injuries. (NTSB/RAR-93/02.)

Moreover, passenger trains are vulnerable to accidents caused by vandalism and sabotage.

- On October 9, 1995, an Amtrak train derailed near Hyder, Arizona, while operating at 50 mph on Southern Pacific Transportation Company trackage because the railroad track structure had been sabotaged. The derailment killed an Amtrak employee who occupied a passenger car which had rolled over onto its side. Seventy-eight passengers were also injured. (FRA Report C-62-95.)

- On May 21, 1993, an Amtrak train traveling at approximately 45 mph derailed after striking two pieces of steel pipe which had been lodged between the rails of a turnout near Opa-Locka, Florida. Six of the train's passengers and crewmembers were injured. (FRA Report C-34-93.)

- On August 12, 1992, an Amtrak train traveling at 79 mph derailed at Newport News, VA, after being unexpectedly diverted into a railroad siding because of a vandalized track

switch. Seventy of the train's passengers and crewmembers were injured. (FRA Report C-52-92.)

Regardless of the cause of an accident, the occupants of a passenger train may risk harm caused by the crushing of the occupant compartment, in which the occupants themselves are crushed, and local penetration into the occupant compartment, where an object intrudes into the occupant compartment and directly strikes an occupant, as demonstrated in the Amtrak accident in Lugoff, South Carolina. Passenger train occupants are also vulnerable to harm from collisions within the train's interior, including loose objects inside the train, such as baggage. For example, the NTSB determined that at least two passengers in a lounge car were injured when they were struck by displaced pedestal seats as a result of the Intercession City, Florida, grade crossing collision on November 30, 1993. The seat columns on four pedestal seats had separated from their floor attachments, allowing them to be projected forward.

A variety of threats to passengers are also posed by fire, broken glazing, electrical shock, and submergence. These dangers may arise following a train derailment or collision, with potentially catastrophic results.

- On September 22, 1993, an accident occurred when an Amtrak train travelling at approximately 72 mph derailed after striking a girder that had been displaced when a towboat, pushing six barges, struck a railroad bridge near Mobile, Alabama. The train's three locomotives, the baggage and dormitory cars, and two of its six passenger cars fell into the water. Forty-two passengers and five crewmembers were killed. All passengers died from asphyxia due to drowning, and the train's three locomotive engineers died from asphyxia and blunt force trauma while inside the lead locomotive that became filled with mud. Two other employees died from smoke inhalation inside the dormitory coach car which had caught on fire. (NTSB Railroad-Marine Accident Report 94/01.)

Further, in the 1996 Silver Spring, Maryland, train collision between the MARC and Amtrak trains, fire erupted after the fuel tank of one of the Amtrak locomotives was breached. Fuel oil spilled into the MARC train's cab car through the openings in the torn car body. The forward section of the cab car was incinerated.

Some dangers to passenger train occupants, such as fire and smoke, may also arise independently without being associated with a train collision or derailment.

- On June 23, 1982, a fire started onboard an Amtrak passenger train in a sleeping car travelling en route to Los Angeles, California. As a result of the fire and smoke, two passengers died, two passengers were seriously injured, and 59 other occupants of the train were treated for smoke inhalation. (NTSB/RAR-83/03.)

Development of Passenger Train Safety Program

This rulemaking is part of several related and complementary efforts by FRA that will contribute to rail passenger safety. FRA has proposed regulations governing emergency preparedness and emergency response procedures for rail passenger service in a separate rulemaking proceeding, designated as FRA No. PTEP-1. See 62 FR 8330, Feb. 24, 1997. In addition, FRA has formed a separate working group (the Passenger Train Emergency Preparedness Working Group) to assist FRA in the development of such regulations. This related proceeding is also addressing some of the issues FRA identified in the ANPRM on passenger equipment safety. Persons wishing to receive more information regarding this other rulemaking should contact Mr. Edward R. English, Director, Office of Safety Assurance and Compliance, FRA, 400 Seventh Street, S.W., Washington, D.C. 20590 (telephone number: 202-632-3349), or David H. Kasminoff, Esq., Trial Attorney, Office of Chief Counsel, FRA, 400 Seventh Street, S.W., Washington, D.C. 20590 (telephone: 202-632-3191).

Further, in response to the New Jersey Transit and MARC train accidents in early 1996, FRA issued Emergency Order No. 20 (Notice No. 1) on February 20, 1996, requiring prompt action to immediately enhance passenger train operating rules and emergency egress and to develop an interim system safety plan addressing the safety of operations that permit passengers to occupy the leading car in a train. 61 FR 6876, Feb. 22, 1996. Both the New Jersey Transit and MARC train accidents involved operations where a cab car occupied the lead position in a passenger train. The Emergency Order explained that in collisions involving the front of a passenger train, operating with a cab car in the forward position or a multiple unit (MU) locomotive, *i.e.*, a self-propelled locomotive with passenger seating, presents an increased risk of severe personal injury or death as compared with locomotive-hauled service when the locomotive occupies the lead position in the train and thereby acts as a buffer for the trailing passenger cars. This risk is of particular

concern where operations are conducted at relatively higher speeds, where there is a mix of various types of trains, and where there are numerous highway-rail crossings over which large motor vehicles are operated. Accordingly, the Emergency Order required in particular that "railroads operating scheduled intercity or commuter rail service * * * conduct an analysis of their operations and file with FRA an interim safety plan indicating the manner in which risk of a collision involving a cab car is addressed." 61 FR 6879.

The Emergency Order also noted that there is a need to ensure that emergency exits are clearly marked and in operable condition on all passenger lines, regardless of the equipment or train control system used. Although FRA Safety Glazing Standards, 49 CFR Part 223, require that passenger cars have a minimum of four emergency window exits "designed to permit rapid and easy removal during a crisis situation," the Silver Spring accident raised concerns that at least some of the occupants of the MARC train attempted unsuccessfully to exit through the windows. The Emergency Order requires "that any emergency windows that are not already legibly marked as such on the inside and outside be so marked, and that a representative sample of all such windows be examined to ensure operability." 61 FR 6880. On February 29, 1996, FRA issued Notice No. 2 to Emergency Order No. 20 to refine three aspects of the original order, including providing more detailed guidance on the emergency egress sampling provision. 61 FR 8703, Mar. 5, 1996.

In addition, FRA submitted a report to Congress on locomotive crashworthiness and working conditions on September 18, 1996, and subsequently referred the issues raised in the report to the Railroad Safety Advisory Committee (RSAC). FRA established RSAC in March of 1996, to provide FRA with advice and recommendations on railroad safety matters. See 61 FR 9740, Mar. 11, 1996. RSAC consists of 48 individual representatives, drawn from 27 organizations representing various rail industry perspectives, and two associate nonvoting representatives from the agencies with railroad safety regulatory responsibility in Canada and Mexico. RSAC will make recommendations as to the best way to address the findings of the report to Congress, including voluntary initiatives, and regulatory standards where appropriate. As a result, FRA may initiate a separate rulemaking proposing equipment safety requirements for both conventional freight and passenger locomotives.

In the context of improving railroad communications, RSAC has established a working group to specifically address communication facilities and procedures, with a strong emphasis on passenger train emergency requirements. FRA expects that group will report recommendations to RSAC early in 1997. FRA anticipates that those recommendations will address the issue of whether there should be redundant communications capability on all passenger trains.

Scope of the Proposed Rule

Through this Notice, FRA proposes to establish a comprehensive set of necessary safety regulations for railroad passenger equipment. These safety standards will improve the safety of rail passenger service.

In commenting on the ANPRM, the General Railway Signal Corporation (GRS) expressed concern that FRA has focused on equipment crashworthiness without sufficiently addressing crash avoidance. GRS noted that the underlying systems which can provide crash avoidance and the related systems safety elements involving a vitally integrated crash avoidance control system include much more than the elements onboard a train.

As explained in the ANPRM (61 FR 30683), and as is evident in Emergency Order No. 20, FRA recognizes that rail passenger safety does involve the safety of the railroad system as a whole, including the track structure, signal and train control systems, operating procedures, and station- and platform-to-train interface design—in addition to passenger equipment safety. To that end, FRA has active rulemaking and research projects in a variety of contexts that address non-equipment aspects of passenger railroad safety, including signal and train control systems. Nevertheless, this proposed rule is designed to address the specific statutory mandate that minimum safety standards be prescribed for the safety of cars used to transport railroad passengers. Signal and train control systems are not the focus of this rulemaking.

FRA received comments from the SBA and on behalf of the Minnesota Transportation Museum, Inc., about this rulemaking's effect on tourist, scenic, historic, and excursion railroads. The proposed rule does not apply to these railroads. Instead, the proposed rule applies to railroads that provide intercity passenger and commuter service. A joint FRA/industry working group formed under RSAC is currently developing recommendations regarding the applicability of FRA regulations,

including this one, to tourist, scenic, historic, and excursion railroads. After appropriate consultation with the excursion railroad associations takes place, passenger equipment safety requirements for these operations may be proposed by FRA that are different from those affecting other types of passenger train operations. Any such requirements proposed by FRA will be part of a separate rulemaking proceeding.

Approach

The proposed regulations are principally designed to apply to two groups of equipment. The first group is identified as Tier I equipment and consists of railroad passenger equipment operated at speeds not exceeding 125 mph. The second group is identified as Tier II equipment and consists of railroad passenger equipment operated at speeds greater than 125 mph but not exceeding 150 mph. FRA is not proposing a rule of general applicability for railroad passenger equipment operated at speeds exceeding 150 mph. FRA believes that the safety of such passenger equipment must be addressed in a rule of a particular applicability for an individual railroad.

The speed break points between Tier I and Tier II equipment have been chosen because most of the nation's intercity passenger and commuter rail equipment has demonstrated an ability to operate safely at speeds up to 125 mph. Nevertheless, FRA recognizes that most of this same equipment is currently operated only at speeds of 110 mph or less. As a result, the proposed rule contains particular suspension system safety requirements for passenger equipment operating at speeds above 110 mph but not exceeding 125 mph, near the transition range from Tier I to Tier II requirements.

Pursuant to 49 U.S.C. 20133(a), FRA may apply some or all of the proposed standards to passenger cars existing at the time the regulations are published, as well as to new cars, but FRA must explain the basis for applying any such standards to existing cars. FRA believes that passenger railroad equipment operating in permanent service in the United States has established a good safety record, proving its compatibility with the operating environment. Moreover, FRA seeks to maximize the benefits resulting from the passenger railroad industry's investment in any safety requirements which FRA may impose through this rule. Accordingly, to be cost effective, most of the proposed requirements would apply only to new or rebuilt equipment.

However, certain features routinely incorporated in existing designs would be required at an earlier date than the more innovative features proposed by this rule. Further, where appropriate, rebuilt equipment would be required to comply with specific requirements.

FRA intends that the rules proposed in this NPRM lead to the issuance of initial passenger equipment safety regulations, which are required by statute to be issued by November 2, 1997. See 49 U.S.C. 20133(b)(1). FRA will propose additional rules for passenger equipment in a second NPRM principally when the results of further research are available. FRA intends that the second NPRM lead to the issuance of final regulations by November 2, 1999, thereby completing the rulemaking within the five-year period required by law. See 49 U.S.C. 20133(b)(2). To that end, FRA convened a meeting of the Working Group on December 10-11, 1996, at the Volpe Center in Cambridge, Massachusetts, to determine and set priorities for the research necessary to address unresolved safety issues identified in prior Working Group meetings. Moreover, FRA hopes that the establishment of final regulations in 1999 will be furthered by APTA's own initiative to develop and maintain recommended industry standards for rail passenger equipment. APTA's effort is being carried out through the Passenger Rail Equipment Safety Standards (PRESS) Task Force, and APTA has invited FRA, FTA, the NTSB, equipment manufacturers, engineering and consulting firms, rail labor, and others with an interest in rail passenger equipment to work with it in developing and effectuating the recommended standards. This represents a substantial and continuing investment by member commuter authorities in the safety of rail passenger service.

System Safety

FRA believes that passenger railroads should carefully evaluate their operations with a view toward enhancing the safety of those operations. The importance of formal safety planning has been recognized in Emergency Order No. 20 and the proposed rule on passenger train emergency preparedness. As noted, Emergency Order No. 20, Notice No. 1, required that "railroads operating scheduled intercity or commuter rail service . . . conduct an analysis of their operations and file with FRA an interim safety plan indicating the manner in which risk of a collision involving a cab car is addressed." 61 FR 6879.

In a letter to FRA dated June 24, 1996, Mr. Donald N. Nelson, President of Metro-North and Chairperson of APTA's Commuter Railroad Committee, announced that commuter railroads are committed to seeking additional opportunities to ensure the safety of their operations beyond efforts such as those made to comply with the interim system safety plan requirements of Emergency Order No. 20. Mr. Nelson explained in particular that commuter railroads will examine and ensure the safety of their operations by adopting a comprehensive system safety plan that:

- (a) Defines the overall safety effort, how it is to be implemented and the staff required to maintain it;
- (b) Establishes the safety interface within the railroad, as well as with its key outside agencies;
- (c) Clearly indicates Senior Management support for implementing the safety plan and the railroad's overall commitment to safety;
- (d) Establishes the safety philosophy of the organization and provides the means for implementation;
- (e) Defines the authority and responsibilities of the safety organization and delineates the safety related authority and responsibilities of other departments; and
- (f) Incorporates safety goals and objectives into the overall corporate strategic plan.

(APTA's Commuter Railroad Committee letter at pages 1 and 2.) Further, the system safety plan is intended to be updated through periodic safety reviews of all operations.

In a letter to FRA dated October 21, 1996, Mr. Donald N. Nelson submitted for FRA's review APTA's "Manual for the Development of a System Safety Plan for Commuter Railroads" (APTA Manual). The APTA Manual is intended to assist commuter railroads in adopting a comprehensive system safety plan by September 1, 1997. In addition, Amtrak recently began a corporate system safety program initiative to make system safety formally an integral part of Amtrak's operations. The value of the system safety process is rapidly being recognized and accepted by the passenger railroad industry.

The System Safety Society (the "Society"), which provided detailed comments in response to the ANPRM, observed that the use of the systems approach to safety is very actively followed in many other industries. The Society noted that the implementation of system safety plans has been observed to improve safety by reducing accidents and incidents. Further, the Society explained that safety plans are

usually updated annually to maintain their utility because of technological improvements and other changed circumstances, including changes in the operating environment, rules and regulations.

The proposed rule contains system safety requirements to be applied to all intercity passenger and commuter rail equipment. Although FRA initially considered addressing system safety requirements for Tier I and Tier II equipment separately, FRA decided to propose system safety requirements which can be applied generally to all types of passenger equipment. Each individual railroad would be required to develop a system safety plan and a system safety program tailored to its specific operation, including train speed. The plan required by this part would be developed as part of a comprehensive system safety process to which commuter railroads are already committed.

Through the system safety process, each railroad would be required to identify, evaluate, and seek to eliminate or reduce the hazards associated with the use of passenger equipment over the railroad system. In particular, the proposed rule would require that each intercity passenger and commuter railroad prepare a system safety plan addressing, at a minimum:

- Fire protection;
- Software safety;
- Equipment inspection, testing, and maintenance;
- Employee training and qualifications; and
- Pre-revenue service acceptance testing of equipment.

However, because FRA is also proposing a comprehensive set of mandatory, equipment safety standards in this rule, FRA is generally not proposing to enforce every element of a railroad's system safety plan. The section-by-section analysis identifies those portions of the system safety plan that will be enforced by FRA. Commenters are requested to address whether FRA should mandate the contents of system safety plans, whether the areas identified by FRA are appropriate, whether additional areas should be added, and whether FRA should enforce other portions of the system safety plans and, if so, which portions. Should the proposed rule require that system safety plans be comprehensive and address the entire railroad system in which the equipment operates? Should the emergency preparedness planning requirements contained in proposed 49 CFR part 239 (See the Passenger Train Emergency Preparedness rulemaking,

designated as FRA No. PTEP-1 (62 FR 8330, Feb. 24, 1997)) be expressly integrated with the system safety planning requirements contained in this proposed part (49 CFR part 238)?

APTA, citing to the fact that the commuter railroads have voluntarily agreed to adopt system safety plans, has objected to FRA issuing any regulations governing such plans. Commenters are requested to address APTA's suggestion that the commuter railroads be allowed to regulate themselves in this area. FRA understands that APTA's system safety approach will be more comprehensive than what FRA is proposing and address each commuter railroad's system more as an integrated whole, not focused principally on rail equipment. FRA will carefully consider the comments received in deciding what approach to take in the final rule with respect to system safety plans.

Passenger railroads should seek to employ all means necessary to reduce the risks associated with the use of passenger equipment over their systems such as by improving the crashworthiness of their equipment or by imposing operational limitations on its use. Further, because many passenger railroads operate at least in part as a tenant on the right-of-way of another railroad and may not in themselves be able to control some of the major system hazards, as demonstrated when an intermodal trailer from a CSXT freight train struck an Amtrak train operating on an adjacent track in Selma, North Carolina, all railroads are encouraged to exploit ways to reduce the risks associated with rail travel to their employees, passengers, and the general public.

Emergency Egress and Access

During the NTSB's investigation of the February 16, 1996, collision between the MARC and Amtrak trains in Silver Spring, Maryland, that agency identified unsafe conditions on MARC's rail cars that had been manufactured by Sumitomo. Concerned that the unsafe conditions identified on these rail cars may exist on other commuter lines subject to FRA oversight, on March 12, 1996, the NTSB recommended that FRA:

Inspect all commuter rail equipment to determine whether it has: (1) easily accessible interior emergency quick-release mechanisms adjacent to exterior passageway doors; (2) removable windows or kick panels in interior and exterior passageway doors; and (3) prominently displayed retroreflective signage marking all interior and exterior emergency exits. If any commuter equipment lacks one or more of these features, take appropriate emergency measures to ensure

corrective action until these measures are incorporated into minimum passenger car safety standards. (Class I, Urgent Action) (R-96-7)

(In a letter to FRA dated June 24, 1996, the NTSB announced that it has added "Safety of Passengers in Railroad Passenger Cars" to its list of "Most Wanted" transportation safety improvements.)

In the discussion accompanying the safety recommendation, the NTSB expressed concern that emergency quick-release mechanisms for the exterior side doors on MARC's Sumitomo rail cars are located in a secured cabinet some distance from the doors that they control, and the emergency controls for each door are not readily accessible and identifiable. Each cabinet door was secured by two fasteners, requiring a screwdriver or coin to open. The NTSB believes that the emergency quick-release mechanisms for exterior doors on MARC rail cars should be well marked and relocated, so that they are immediately adjacent to the door which they control and readily accessible for emergency escape.

Access to Emergency Door-Release for Power-Operated Doors

In response to the NTSB's recommendation, FRA inspected a total of 1,250 pieces of equipment in use on 16 commuter organizations. In addition to MARC rail cars, FRA found that some commuter railroads operate cars with power doors equipped with emergency door-release levers located inside cabinets requiring special tools to enter. In large part, these railroads have committed to the voluntary elimination of latches requiring tools or other implements to access the emergency-release levers on power-operated doors.

FRA convened a joint meeting of the Passenger Equipment Safety Standards Working Group and the Passenger Train Emergency Preparedness Working Group on March 26, 1996, to discuss the NTSB's recommendations and incorporate the Safety Board's findings, as appropriate, into each working group's rulemaking. In accordance with the consensus of the working groups, FRA is proposing in §§ 238.237 and 238.441 of the rule that train passengers and crewmembers be able to access door-release mechanisms without the use of any tool or other implement.

Relocation of Emergency Door-Release

NTSB advisors to the Working Group clarified that the recommendation to relocate emergency door-release mechanisms refers to exterior side doors located in end vestibules partitioned

from the passenger compartment of the rail vehicle. If emergency door-release mechanisms are located inside the passenger compartments of such vehicles, exiting the vehicles in an emergency through side doors in the vestibules may be complicated as passengers try to locate the mechanisms and move between the vestibule and passenger compartment areas.

In response to the NTSB's safety recommendation, passenger railroads that operate rail equipment with end vestibules have agreed to relocate emergency door-release mechanisms so that they are located adjacent to the doors which they control. However, agreement could not be reached on a time-table for retrofitting existing equipment. APTA has proposed that the retrofit be required on all such passenger equipment when it is overhauled in the course of each railroad's equipment overhaul cycle. APTA anticipates that under this process retrofitting the entire fleet of affected equipment will be accomplished within 10 to 15 years.

FRA believes that the retrofit must be accomplished sooner to ensure the safety of passenger train occupants. Consequently, FRA is proposing in § 238.237 that for equipment operated at speeds not exceeding 125 mph (Tier I equipment), within two years of the effective date of the final rule each powered, exterior side door in a vestibule that is partitioned from the passenger compartment of a passenger car be equipped with a manual override that is: (1) capable of opening the door without power from inside the car; (2) located adjacent to the door which it controls; and (3) designed and maintained so that a person may access the override device from inside the car without requiring the use of any tool or other implement.

FRA expects that railroads will expedite this retrofit program and believes that this retrofit can be completed well in advance of the 2-year deadline. APTA maintains that the supply industry cannot provide the necessary materials to complete the retrofit in such time without unreasonable increases in costs, and believes that a 3 to 5 year time frame is needed. (Commenters are requested to address whether a shorter or longer time period should be established and, if so, provide the rationale for the time period that the commenter recommends. Railroads are requested to identify the number of cars that are not yet retrofitted.) Further, before any equipment may be introduced for service at speeds exceeding 125 mph but not exceeding 150 mph (Tier II

equipment), FRA is proposing in § 238.441 that each powered, exterior side door on a passenger car be equipped with a manual override meeting the above and additional requirements.

FRA believes that the cost of meeting the retrofit requirement will be \$3.7 million dollars, and recognizes that it is not clear whether the occupants of the MARC train in the Silver Spring, Maryland, accident could have opened the vestibule exterior side doors after the collision, assuming that the emergency-release had been employed. The NTSB did note that the left and right rear exterior side doors of the first car and the front interior end door and the right front exterior door of the second car on the MARC train were jammed. However, FRA believes it must institute the retrofit requirement to decrease the risk that passengers cannot rapidly exit a train in a life-threatening situation.

FRA recognizes that passenger railroads have located door-release mechanisms away from the doors which they control to discourage passengers from exiting trains in non-emergency situations. When no emergency is present, passengers exiting trains along the railroad right-of-way unnecessarily risk exposure to oncoming trains, electrical hazards, and other dangerous conditions. In consequence, the proposed rule permits railroads to protect emergency door-release mechanisms from casual or inadvertent use with a cover or a screen. However, the cover or screen must be capable of removal by a 5th-percentile female without the use of any tool or other implement. If the method of removing the protective cover or screen entails breaking or shattering it, the cover or screen shall be scored, perforated, or otherwise weakened so that a 5th-percentile female can penetrate the cover or screen with a single blow of her fist without injury to her hand.

Additional Egress Issues

The NTSB noted that none of the car doors on the MARC train involved in the Silver Spring, Maryland, accident had removable windows or pop-out emergency escape panels ("kick panels") for use in an emergency. In addition, the NTSB stated that several train passengers were unaware of the locations of emergency exits, and none knew how to operate them. The NTSB found that the interior emergency window decals were not prominently displayed and that one car had no interior emergency window decals. Also, the exterior emergency decals were often faded or obliterated, and the

information on them, when legible, directed emergency responders to another sign at the end of the car for instructions on how to open emergency exits.

Through the issuance of Emergency Order No. 20, FRA has addressed on an interim basis the inspection of required emergency exits, and emergency exit signage and marking. Further, FRA is proposing requirements concerning the marking of emergency exits, as well as instructions for their use, in the related rulemaking on passenger train emergency preparedness. FRA shares the NTSB's concern about passenger egress in an emergency; however, FRA believes that the NTSB's suggestion to install kick panels is best limited to interior doors to ensure passage through a train in an emergency—and not applied to exterior doors.

To the best of FRA's knowledge, the concept of kick panels has not been utilized in North American rail equipment. Installing kick panels below the window levels in exterior doors was evaluated by FRA, with concurrence from the joint working groups, as unacceptable for safety reasons. Because passenger railroads have encountered recurring situations in which passengers have inappropriately exited moving trains, leading to death or serious injury, introducing kick panels in exterior doors would create an unacceptable risk of inadvertent use, particularly by children. Penetration of occupied areas by objects from the outside is also a potential concern.

Use of kick panels to open passageways through a train has merit. If panels can be made sufficiently large without decreasing the functionality of doors in normal operation, such a feature may facilitate evacuation through the length of the train if exterior side doors are jammed. Evacuation throughout the length of the train is often the safest route of egress in situations such as fires, derailments in multiple track territory, and incidents in third-rail powered commuter service. Accordingly, FRA is proposing in § 238.441 of the rule that Tier II passenger car end doors be equipped with a kick-out panel, pop-out window or other similar means of egress in the event the doors will not open.

Unlike a Tier II passenger train which should operate as a fixed unit, the interchangeable use of some cab cars and MU locomotives as leading and trailing units on a Tier I passenger train will complicate analyzing the efficacy of installing such panels on Tier I equipment. It would be unacceptable to have a removable panel at the point of a train where objects or fluids might

enter the vehicle as a result of a highway-rail grade crossing accident or other collision. As a result, FRA will further examine the concerns involving the use of kick panels on Tier I equipment in the second phase of this rulemaking.

Additional emergency egress and access topics addressed in this proposed rule are discussed below in the Emergency Systems section of this preamble. Emergency egress and access topics are also addressed in the related rulemaking on passenger train emergency preparedness. See 62 FR 8330, Feb. 24, 1997.

Power Brake Inspection and Testing

In 1992, Congress amended the Federal rail safety laws by adding certain statutory mandates related to power brake safety. These amendments specifically address the revision of the power brake regulations and state in pertinent part:

(r) POWER BRAKE SAFETY.—(1) The Secretary shall conduct a review of the Department of Transportation's rules with respect to railroad power brakes, and not later than December 31, 1993, shall revise such rules based on such safety data as may be presented during that review.

* * * * *
Pub. L. No. 102-365, § 7; codified at 49 U.S.C. 20141, superseding 45 U.S.C. 431(r).

In response to the statutory mandate, various recommendations to improve power brake safety, and due to its own determination that the power brake regulations were in need of revision, FRA published an ANPRM on December 31, 1992, concerning railroad power brake safety. See 57 FR 62546. The ANPRM provided background information and presented questions on various subjects related to intercity passenger and commuter train operations, including: training of testing and inspection personnel; electronic braking systems; cleaning, oiling, testing, and stenciling (COT&S) requirements; performance of brake inspections; and high speed passenger train brakes. Following publication of the ANPRM, FRA conducted a series of public workshops. The ANPRM and the public workshops were intended as fact-finding tools to elicit views of those persons outside FRA charged with ensuring compliance with the power brake regulations on a day-to-day basis.

Furthermore, on July 26, 1993, the NTSB made the following recommendation to FRA: "Amend the power brake regulations, 49 Code of Federal Regulations 232.12, to provide appropriate guidelines for inspecting brake equipment on modern passenger

cars." (R-93-16). The recommendation arose out of the NTSB's investigation of the December 17, 1991, derailment of an Amtrak passenger train in Palatka, Florida. The derailed equipment struck two homes and blocked a street north of the Palatka station. The derailment resulted in eleven passengers sustaining serious injuries and 41 others receiving minor injuries. In addition, five members of the operating crew and four onboard service personnel received minor injuries. By letter dated September 16, 1993, FRA told the NTSB that it was in the process of reviewing and rewriting the power brake regulations and would consider the NTSB's recommendation during the process.

Based on comments and information received, FRA published an NPRM in 1994 regarding revision of the power brake regulations which contained specific requirements related to intercity passenger and commuter train operations. These specific requirements included: general design requirements; movement of defective equipment; employee qualifications; inspection and testing requirements; single car testing requirements and periodic maintenance; operating requirements; and requirements for the introduction of new train brake system technology. See 59 FR 47722-47753, September, 16, 1994.

Following publication of the 1994 NPRM (59 FR 47676), FRA held a series of public hearings in 1994 to allow interested parties the opportunity to comment on specific issues addressed in the 1994 NPRM. Public hearings were held in Chicago, Illinois, on November 1-2; in Newark, New Jersey, on November 4; in Sacramento, California, on November 9; and in Washington, D.C. on December 13-14, 1994. These hearings were attended by numerous railroads; organizations representing railroads; labor organizations; rail shippers; and State governmental agencies. Due to the strong objections raised by a large number of commenters, FRA announced by notice published on January 17, 1995, that it would defer action on the 1994 NPRM and permit the submission of additional comments prior to making a determination as to how it would proceed in this matter. See 60 FR 3375.

Based on these considerations and after review of all the comments submitted, FRA determined that in order to limit the number of issues to be examined and developed in any one proceeding it would proceed with the revision of the power brake regulations via three separate processes. In light of the testimony and comments received

on the 1994 NPRM, emphasizing the differences between passenger and freight operations and the brake equipment utilized by the two, FRA decided to separate passenger equipment power brake standards from freight equipment power brake standards. As passenger equipment power brake standards are a logical subset of passenger equipment safety standards, FRA requested the Passenger Equipment Safety Standards Working Group to assist FRA in developing appropriate power brake standards for passenger equipment and then decided that they would be included in this NPRM. See 49 U.S.C. 20133(c). In addition, a second NPRM covering freight equipment power brake standards would be developed with the assistance of FRA's Railroad Safety Advisory Committee. See 61 FR 29164, June 7, 1996. Furthermore, in the interest of public safety and due to statutory as well as internal commitments, FRA determined that it would separate the issues related to two-way end-of-train-telemetry devices from both the passenger and freight issues. FRA convened a public regulatory conference and published a final rule on the subject on January 2, 1997. See 62 FR 278.

Beginning in December of 1995, the Passenger Equipment Safety Standards Working Group adopted the additional task of attempting to develop power brake standards applicable to intercity passenger and commuter train operations and equipment. The Working Group met on four separate occasions in the last six months, which consisted of ten days of meetings, with a good portion of these meetings being devoted to discussion of power brake issues. From the outset, a majority of the members, as well as FRA, believed that any requirements developed by the group regarding the inspection and testing of the brake equipment should not vary significantly from the current requirements and should be consistent with current industry practice.

FRA's accident/incident data related to intercity passenger and commuter train operations support the assumption that the current practices of these operations in the area of power brake inspection, testing, and maintenance are for the most part sufficient to ensure the safety of the public. Between January 1, 1990 and October 31, 1996, there were only five brake related accidents involving commuter and intercity passenger railroad equipment. No casualties resulted from any of these accidents and the total damage to railroad equipment totaled approximately \$650,000, or \$96,000

annually. In addition, between January 1, 1995 and October 31, 1996, FRA inspected approximately 13,000 commuter and intercity passenger rail units for compliance with 49 CFR part 232. The defect ratio for these units during this period was approximately 0.8 percent. Furthermore, during this same period FRA inspected approximately 6,300 locomotives for compliance with 49 CFR part 229. The brake defect ratio for these units was approximately 4.65 percent. Consequently, the defect ratio for brake related defects on locomotives and other passenger equipment during this period was approximately 2.08 percent.

The existing regulations covering the inspection and testing of the braking systems on passenger trains are contained in 49 CFR part 232. The current regulations do provide some requirements relevant to passenger train operations, including: initial terminal inspection and testing, intermediate inspections, running tests, and general maintenance requirements. See 49 CFR 232.12, 232.13(a), 232.16, and 232.17. However, most of the existing regulations are written to address freight train operations and do not sufficiently address the unique operating environment of commuter and intercity passenger train operations or the equipment currently being used in those operations. Therefore, it has been necessary for FRA to provide interpretations of some of the current regulations in order to address these unique concerns.

Currently, all non-MU (multiple unit) commuter trains that do not remain connected to a source of compressed air overnight and all MU commuter trains equipped with RT-5 or similar brake systems must receive an initial terminal inspection of the brake system pursuant to § 232.12(c)-(j) prior to the train's first departure on any given calendar day. All non-MU commuter trains that remain connected to a source of compressed air overnight are permitted to receive an initial terminal inspection of the brake system sometime during each 24-hour period in which they are used. Furthermore, all intercity passenger trains must receive an initial terminal inspection of the brake system at the point where they are originally made up and must receive an intermediate inspection in accordance with § 232.12(b) every 1,000 miles.

As noted previously, most of the members of the Working Group believed that any requirements developed by the group regarding the inspection and testing of the brake equipment should not vary significantly from the current requirements and should be consistent

with current industry practice. However, the Working Group was unable to reach consensus on power brake standards, despite the positing of multiple alternatives, use of a facilitator, and the foundation provided by the 1994 NPRM. The Working Group identified and discussed options with which the agency and labor can agree, and others with which FRA and the railroads can agree. However, bridging the gap between those various options proved elusive. Consequently, as the Working Group could not reach any type of consensus on the inspection and testing requirements, it was determined that FRA would address these issues unilaterally, based on the information and discussions provided by the Working Group and the information gathered from the 1994 NPRM. FRA is interested in receiving comments on the brake tests that it has developed given the differences in the positions of the various parties.

The Working Group discussed various options regarding the types of brake inspections that should be required as well as when and how these inspections should be performed. Labor representatives, particularly the BRC, insisted that a comprehensive power brake inspection (i.e., something similar to the initial terminal brake inspections currently required under § 232.12(c)-(j)) must be performed prior to a train's first run on a given calendar day. The BRC expressed concern that, as equipment lays over between the evening commuter cycle and the first trip of the morning, vandalism, weather changes, or other factors could affect the integrity of the air brake system. The BRC also believes that it is necessary for the first inspection of the day to determine whether the brake shoes and the disc pads actually apply as intended. The BRC further contends that in order to perform a comprehensive inspection equivalent to an initial terminal inspection the train must be walked or otherwise inspected on a car-to-car basis. In addition, the BRC contends that these principal inspections should be performed only by carmen or other qualified mechanical personnel as they are the only employees sufficiently trained to perform these inspections.

Representatives of intercity passenger and commuter railroads expressed the desire to have the flexibility to conduct a comprehensive in-depth inspection of the train brake system sometime during the day in which the equipment is utilized. These parties argued that safety would be better served by allowing the railroads the flexibility to conduct these inspections on a daily basis as it would allow the railroads to conduct the

inspections at locations that are more conducive to permitting a full inspection of the equipment than many of the outlying locations where trains are stationed overnight and where the ability to observe all the equipment may be hampered. It is further contended that, if trains are required to receive the equivalent of an initial terminal inspection at these outlying points, then many of these inspections may be performed by individuals not as fully qualified as a mechanical inspector. Whereas, if the railroads are allowed some flexibility in conducting these type of inspections, then the equipment can be moved to a location where a fully qualified mechanical inspector can perform a detailed brake inspection under optimum conditions, perhaps in conjunction with a daily mechanical inspection.

Several parties also pointed out that, with proper maintenance, "tread brake units" and other friction brake components, commonly used in commuter train operations, are highly reliable and that the non-functioning of any individual unit would in no way compromise the overall safety of the train. Furthermore, permitting the inspection of these types of brake components in the middle of the day, rather than at the beginning of the day, involves no greater safety risk to passengers because friction brake systems and their components degrade in performance based largely on use, and nothing short of a continuous brake inspection can guarantee 100-percent performance at all times. Railroad representatives suggested an inspection scheme that would permit an in-depth, comprehensive brake inspection to be performed sometime during the day in which the equipment is used with a brake inspection being performed prior to the first run of the day verifying the continuity of the trainline by performing a set and release on the rear car of the train. In addition, one commuter railroad also requested relief from performing Class I inspections on trains operated in weekend service due to the shortage of mechanical inspectors currently employed on those shifts.

Based on consideration of the discussions held in the Working Group meetings, outlined above, as well as information obtained in relation to the 1994 NPRM, FRA proposes to abandon the terminology related to the power brake inspection and testing requirements contained in the current regulations, which is generally based on the locations where the inspections and tests are performed (i.e., initial terminal, intermediate locations). In its stead, FRA proposes to identify various classes

of inspections based on the duties and type of inspection required, such as: Class I; Class IA; and Class II. This is similar to the approach taken by FRA in the 1994 NPRM. See 59 FR 47736-40. FRA believes that this type of classification system will avoid confusion with the power brake inspection and testing requirements applicable to freight operations and will avoid the connotations historically attached to the current terminology. FRA also believes this approach is better suited for providing operational flexibility to commuter operations while maintaining the safety provided by the current inspection and testing requirements. Although FRA proposes a change in the terminology used to describe the various power brake inspections and tests, the requirements of these inspections and tests will closely track the current requirements with some modifications made to address the unique operating environment of, and equipment operated in, commuter and intercity passenger train service. Members of the Working Group appeared receptive to this kind of classification system and discussed various options using some of this terminology. Consequently, FRA proposes four different types of brake inspections to be performed by commuter and intercity passenger railroads some time during the operation of the equipment. FRA proposes the terms "Class I," "Class IA," "Class II," and "running brake test" to identify the four types of brake inspections required by this proposal.

FRA also proposes to divide passenger train operations into two distinct types for purposes of brake inspections and testing. FRA recognizes that there are major differences in the operations of commuter or short-distance intercity passenger trains, and long-distance intercity passenger trains. Commuter and short-distance intercity passenger trains tend to operate for fairly short distances between passenger stations and generally operate in relatively short turn-around service between two terminals several times in any given day. In contrast, long-distance intercity passenger trains tend to operate for long distances, with trips between the beginning terminal and ending terminal taking a day or more and traversing multiple states with relatively long distances between passenger stations. Consequently, FRA proposes to use and define the terms "commuter train," "short-distance intercity passenger train," and "long-distance intercity passenger train" in order to identify the inspection and

testing requirements associated with each. For the most part, commuter and short-distance intercity passenger trains are treated similarly, whereas, long-distance intercity passenger trains have slightly different proposed inspection and testing requirements. In addition, FRA proposes slightly different requirements with regard to the movement of defective equipment in long-distance intercity passenger trains (see the discussion below on the "Movement of Equipment with Defective Brakes").

APTA, in its comments on a draft of the NPRM, expressed opposition to the proposed Class IA brake test. APTA's position is that brake tests prior to a train's first departure in any day should be limited to a pre-departure set and release followed by a running test of the brakes. APTA also expresses the belief that the proposed NPRM Class I and Class II requirements go well beyond existing brake inspection processes and that which is required for safety, and that these requirements will increase costs dramatically.

A. Commuter and Short-Distance Intercity Passenger Trains Require a Class I Brake Test Sometime During a Day the Equipment Is Used

The proposed Class I brake test basically requires an inspection similar to an initial terminal inspection as currently described at § 232.12(c)-(j), but is somewhat more extensive and specifically aimed at the types of equipment being used in commuter and intercity passenger train service. A Class I brake test would require an inspection of the application and release of the friction brakes on each side of each car as well as an inspection of the brake shoes, pads, discs, rigging, angle cocks, piston travel, and brake indicators if the equipment is so equipped. The Class I brake test would also require testing of the communication signal system and the emergency braking control devices. In addition, all supplemental braking systems would be required to be inspected and be working. In recognition of the advanced technology and various designs used in many of these operations, which make observation of the piston travel virtually impossible, FRA proposes to permit the inspection of the piston travel to be conducted either through direct observation or by observation of a brake actuator or the clearance between the brake shoe and the wheel. Furthermore, FRA proposes to require a brake pipe leakage test only when leakage will affect service performance.

Although FRA agrees with the position advanced by many labor

representatives that some sort of car-to-car inspection must be made of the brake equipment prior to the first run of the day, FRA does not agree that it is necessary to perform a full Class I brake test before the first run in order to ensure the proper functioning of the brake equipment. As FRA proposes that Class I brake tests be a comprehensive inspection of the braking system, including the proper operation of supplemental braking systems, FRA believes that commuter and short-distance intercity passenger train operations must be permitted some flexibility in conducting these inspections. Consequently, FRA proposes to require that commuter and short-distance intercity passenger train operations perform a Class I brake test sometime during the calendar day in which the equipment is used. FRA believes that the flexibility permitted by this proposed requirement will allow these railroads to move equipment to locations that are most conducive to the inspection of the brake equipment and would allow these railroads to combine the daily mechanical inspections with this brake inspection for added efficiency.

Furthermore, as FRA intends for these Class I brake inspections to be in-depth inspections of the entire braking system which most likely will be performed only one time in any given day in which the equipment is used, FRA believes that these inspections must be performed by individuals possessing not only the knowledge to identify and detect a defective condition in all of the brake equipment required to be inspected but also the knowledge to recognize the interrelational workings of the equipment and the ability to "troubleshoot" and repair the equipment. Therefore, FRA proposes that only qualified mechanical inspectors be permitted to perform Class I brake tests.

Currently, initial terminal air brake inspections are conducted prior to the first run of the day on 554 commuter train sets by mechanical inspectors and on 168 commuter train sets by train crews or other personnel who could not be fully qualified as mechanical inspectors. Typically, commuter and short-distance intercity passenger trains receive more than one initial terminal test each day, even if this is not required due to the equipment being left "off air." See 49 CFR 232.12(a). Often these additional tests are conducted sometime during the middle of the day by train crews or mechanical employees. Although most commuter and short-distance intercity operations voluntarily perform an initial terminal brake

inspection with mechanical employees some time during the day, there is no requirement to do so. In addition, there is a certain percentage of equipment where the principal brake inspections are currently being performed strictly by train crews rather than by mechanical employees. Consequently, FRA believes that the proposed requirement incorporates the current best practices of the industry and will, at a minimum, ensure that the braking systems on all commuter and short-distance intercity equipment will be inspected at least once each day by a fully qualified mechanical inspector.

FRA has not proposed any special provisions for weekend operations as suggested by some members of the Working Group. FRA recognizes this is a difficult issue. Existing operations generally involve using particular sets of equipment on only one day during the weekend to avoid the need to refuel. On the one hand, there is no specific data suggesting that existing weekend operations involving inspections exclusively by train crew members have created a safety hazard. Yet, the rationale for requiring daily attention by mechanical forces, a proposition generally accepted by Working Group members, would appear to apply equally to weekend periods. FRA believes that adjustments might be made to weekend operations that might avoid significant new expense while providing expert attention to inspection of the equipment. Accordingly, FRA seeks additional information on the costs and benefits of requiring that Class I brake inspections and daily mechanical inspections be conducted by qualified mechanical inspectors, as well as any suggestions for alternative means of addressing this issue.

B. Commuter and Short-Distance Intercity Passenger Trains Require at Least a Class IA Brake Test Prior to the Train's First Departure in Any Given Day

Although FRA agrees with the position advanced by many labor representatives that some sort of car-to-car inspection must be made of the brake equipment prior to the first run of the day, FRA does not agree that it is necessary to perform a full Class I brake test in order to ensure the proper functioning of the brake equipment in all situations. However, contrary to the position espoused by APTA, FRA believes that something more than just a determination that the brakes on the rear car set and release is necessary.

Currently, the quality of initial terminal tests performed by train crews is likely adequate to determine that

brakes apply on each car. However, most commuter equipment utilizes "tread brake units" in lieu of cylinders and brake rigging of the kind prevalent on freight and some intercity passenger cars. It is undoubtedly the case that train crew members do not verify application of the brakes by tapping brake shoes while the brakes are applied, the only effective means of determining that adequate force is being applied. This is one reason why the subject railroads typically conduct redundant initial terminal tests at other times during the day. Further, train crews are not asked to inspect for wheel defects and other unsafe conditions, nor should they be asked to do so, given the conditions under which they are asked to inspect and the training they receive.

FRA proposes that, at a minimum, a Class IA brake test be performed prior to a commuter or short-distance intercity passenger train's first departure on any given day. FRA believes that the proposed Class IA brake is sufficiently detailed to ensure the proper functioning of the brake system yet not so intensive that it requires individuals to perform an inspection for which they are not qualified.

The proposed Class IA brake test is somewhat less comprehensive than a Class I brake test but includes a detailed inspection of the brake system to verify the continuity of the brake system and the proper functioning of the brake valves on each car. A Class IA brake test would be similar to the intermediate brake inspection currently required for freight trains prescribed at § 232.13(d)(1). A Class IA brake test would generally require a walking inspection of the set and release of the brakes on each car; however, the proposal would allow brake indicators to be used to verify the set and release if the railroad determines that operating conditions pose a safety hazard to an inspector walking along the train. The Class IA brake test would also require a leakage test if leakage affects service performance, as well as an inspection of: angle cocks; piston travel, if determinable; brake indicators; emergency brake control devices; and communication of brake pipe pressure changes at the rear of train to the controlling locomotive. FRA believes that a qualified mechanical inspector or a properly trained and qualified train crew member could perform a Class IA brake test.

C. Long-distance Intercity Passenger Trains Require a Class I Brake Test Prior to Departure From an Originating Terminal and Once Each Calendar Day the Equipment Is Used or Every 1,500 Miles, Whichever Occurs First

As noted above, FRA recognizes the differences between commuter or short-distance intercity operations and long-distance intercity passenger train operations. Long-distance intercity passenger trains do not operate in shorter turn around service over the same sections of track on a daily basis for the purpose of transporting passengers from major centers of employment. Instead, these trains tend to operate for extended periods of time, over long distances with greater distances between passenger stations and terminals. Further, these trains may operate well over 1,000 miles in any 24 hour period. Thus, the opportunity for conducting inspections on these trains is somewhat diminished. Therefore, FRA believes that a thorough inspection of the braking system on these types of operations must be conducted prior to the train's departure from an initial starting terminal. Consequently, FRA will not permit the use of Class IA brake tests for these trains and proposes to require that a Class I brake inspection be performed on long-distance intercity passenger trains prior to departure from an initial terminal. FRA does not believe there would be any significant burden placed on these operations as the current regulations require that an initial terminal inspection be performed at these locations. Furthermore, virtually all of the initial terminal inspections currently conducted on these types of trains are performed by individuals who would be considered qualified mechanical employees under this proposal.

FRA also recognizes that these long-distance intercity passenger trains could conceivably travel over 3,000 miles if Class I inspections were required only once every 24 hours the equipment is in service as proposed for commuter and short-distance intercity passenger trains. Thus, FRA believes that some outside mileage limit must be placed on these trains between brake inspections. Currently, a passenger train is permitted to travel no further than 1,000 miles from its initial terminal, at which point it must receive an intermediate inspection of brakes that includes application of the brakes and the inspection of the brake rigging to ensure it is properly secured. See 49 CFR 232.12(b). However, in recognition of the improved technology used in passenger train brake systems combined

with the comprehensive nature of the proposed Class I brake tests and mechanical safety inspections both being performed by qualified mechanical inspectors, FRA proposes to permit long-distance passenger trains to travel up to 1,500 miles between Class I brake tests. Consequently, FRA proposes to eliminate the 1,000-mile inspection for these trains and proposes to require that the proposed Class I brake test be performed once every calendar day that the equipment is used or every 1,500 miles, which ever occurs first.

D. The Brake Inspection and Testing Intervals for Long-distance Intercity Passenger Trains Apply to All Tier II Equipment Regardless of Whether the Equipment is Used in Short- or Long-distance Intercity Trains

FRA also proposes to apply the brake inspection and testing intervals proposed for long-distance passenger trains to all Tier II equipment (i.e., equipment operating at speeds greater than 125 mph but not exceeding 150 mph) regardless of whether it is used in short- or long-distance intercity trains. As FRA proposes to permit operators of Tier II equipment to develop inspection and testing criteria and procedures, these operations will be required to develop a brake test that is equivalent to a Class I brake test for Tier II equipment. Due to the speeds at which this equipment will be allowed to operate, FRA believes it is a necessity that an equivalent Class I brake test be performed on Tier II equipment before it departs from its initial terminal. Likewise, FRA proposes to require that the equivalent Class I brake test be performed every calendar day in which the equipment is used or every 1,500 miles, whichever comes first.

E. Class II Brake Test Required Where Minor Changes to a Train Consist Occur

In addition to the proposed Class I and Class IA brake tests, FRA also proposes a Class II brake test. The proposed Class II brake test is an inspection intended to verify the continuity of the train brake system and is similar to the intermediate terminal inspection currently prescribed at § 232.13(a). A Class II brake test would basically require a set and release of the brakes on the rear car. The proposed Class II test would be required in those circumstances where minor changes to a train consist occur. These include the change of a control stand, the removal of cars from the consist, the addition of previously tested cars, and the situations in which an operator first takes control of the train.

F. Running Brake Tests

FRA also proposes to require a running brake test as soon as conditions safely permit it to be conducted after a train receives a Class I, Class IA, or Class II brake test. FRA believes that this test should be conducted in accordance with each railroad's operating rules. The "running brake test" requirement is similar to the "running test" requirements currently contained at § 232.16.

Movement of Equipment With Defective Brakes

The current regulations do not contain requirements pertaining to the movement of equipment with defective power brakes. The movement of equipment with these types of defects is currently controlled by a specific statutory provision originally enacted in 1910, which states:

(a) GENERAL.—A vehicle that is equipped in compliance with this chapter whose equipment becomes defective or insecure nevertheless may be moved when necessary to make repairs, without a penalty being imposed under section 21302 of this title, from the place at which the defect or insecurity was first discovered to the *nearest available place at which the repairs can be made*—

(1) On the railroad line on which the defect or insecurity was discovered; or

(2) At the option of a connecting railroad carrier, on the railroad line of the connecting carrier, if not further than the place of repair described in clause (1) of this subsection.

49 U.S.C. 20303(a) (emphasis added).

Although there is no limit contained in 49 U.S.C. 20303 as to the number of cars with defective equipment that may be hauled in a train, FRA has a longstanding interpretation which requires that, at a minimum, 85 percent of the cars in a train have operative brakes. FRA bases this interpretation on another statutory requirement which permits a railroad to use a train only if "at least 50 percent of the vehicles in the train are equipped with power or train brakes and the engineer is using the power or train brakes on those vehicles and on all other vehicles equipped with them that are associated with those vehicles in a train." 49 U.S.C. 20302(a)(5)(B). As originally enacted in 1903, section 20302 also granted the Interstate Commerce Commission (ICC) the authority to increase this percentage, and in 1910 the ICC issued an order increasing the minimum percentage to 85 percent. See 49 CFR 232.1, which codified the ICC order.

As virtually all freight cars are presently equipped with power brakes and are operated on an associated

trainline, the statutory requirement is in essence a requirement that 100 percent of the cars in a train have operative power brakes, unless being hauled for repairs pursuant to 49 U.S.C. 20303. Consequently, FRA currently requires that equipment with defective or inoperative air brakes make up no more than 15 percent of the train and that, if it is necessary to move the equipment from where the railroad first discovered it to be defective, the defective equipment be moved no further than the nearest place on the railroad's line where the necessary repairs can be made or, at the option of the receiving carrier, to a repair point that is no further than the reposit on the delivering line.

The requirements regarding the movement of equipment with defective or insecure brakes noted above can and do create safety hazards as well as operational difficulties in the area of commuter and intercity passenger railroad operations. As the provisions regarding the movement of defective brake equipment were written almost a century ago, they do not address the realities of these types of operations in today's world. Strict application of the requirements has the potential of causing major disruptions of service which result in the creation of serious safety and security problems. For example, requiring repairs to be made at the nearest location where the necessary repairs can be made could result in passengers being discharged between stations where adequate facilities for their safety are not available or in the overcrowding of station platforms and trailing trains due to discharging passengers from a defective train at a location other than the passenger's destination. In addition, strict application of the statutory requirements could result in the moving of trains with defective brake equipment against the current of traffic during busy commuting hours. Irregular movements of this type increase the risk of collisions on the railroad. Furthermore, many of today's commuter train operations often utilize six cars or less in trains and in many instances operate just two-car trains. Consequently, the necessity to cut out the brakes on one car can easily result in noncompliance with the 85-percent requirement for hauling the car for repairs, thus prohibiting the train's movement and resulting in the same type of safety problems noted above.

FRA has attempted to recognize the nature of commuter and intercity passenger operations and the importance of addressing the safety of passengers, as well as avoiding

disruption of this service, when applying the requirements regarding the movement of equipment with defective brakes on a day-to-day basis. In addition, the representatives of commuter and intercity passenger train operations participating in this proceeding have requested that the regulations be brought up to date, recognizing that brakes will have to be cut out en route from time to time (e.g., because of damage from debris placed on the track structure or because of sticking brakes) and that contemporary braking systems and established stopping distances provide a very considerable margin of safety. Furthermore, speed restrictions can readily be used to compensate for the loss of brakes on a minority of cars. FRA believes that affirmatively recognizing appropriate movement restrictions would actually enhance safety, since compliance with the existing restrictions is potentially unsafe.

Representatives from APTA proposed a method of updating the current requirements regarding the movement of commuter passenger equipment with defective brakes to bring them more in line with the realities of today's operations. The Working Group discussed the proposal at length, making various revisions. Although the Working Group did not reach consensus on the issue, FRA believes that the proposed requirements are within the scope of options discussed by the group. FRA believes that the proposed restrictions are very conservative and effectively ensure a high level of safety in light of the reliability of braking systems currently used in commuter and intercity passenger train operations.

FRA recognizes that some of the proposed restrictions are not in accord with the requirement contained in 49 U.S.C. 20303(a) that cars with defective or insecure brakes be moved to the "nearest" location where the necessary repairs can be made. However, FRA does have authority under 49 U.S.C. 20306, entitled "Exemption for technological improvements," to establish the proposed restrictions. Section 20306 provides:

[T]he Secretary of Transportation may exempt from the requirements of this chapter railroad equipment or equipment that will be operated on rails, when those requirements preclude the development or implementation of more efficient railroad transportation equipment or other transportation innovations under existing law.

This provision was originally enacted as a part of the Rock Island Railroad Transition and Employee Assistance Act to authorize the use of RoadRailer[®] trailers as freight cars. See Pub. L. 96-

254 (May 30, 1980). Although it could be argued that the purpose of the provision is too narrow to comprehend the instant application, FRA believes that the use of the provision as contemplated in this proposal is consistent with the authority granted the Secretary of Transportation in 49 U.S.C. 20306. As noted previously, the statutory requirements regarding the movement of equipment with defective brake equipment were written nearly a century ago and, in FRA's opinion, were focused generally on the operation of freight equipment and did not contemplate the types of commuter and intercity passenger train operations currently prevalent throughout the nation. Since the original enactment in 1910 of the provisions now codified at 49 U.S.C. 20303(a), there have been substantial changes both in the nature of the operations of passenger trains as well as in the technology used in those operations.

Contemporary passenger equipment incorporates various types of advanced braking systems; in some cases these include electrical activation of brakes on each car (with pneumatic application through the train line available as a backup). Dynamic brakes are also typically employed to limit thermal stresses on friction surfaces and to limit the wear and tear on the brake equipment. Furthermore, the brake valves and brake components used today are far more reliable than was the case several decades ago. In addition to these technological advances, the brake equipment used in commuter and intercity passenger train operations incorporate advanced technologies not found with any regularity in freight operations. These include:

- The use of brake cylinder pressure indicators which provide a reliable indication of the application and release of the brakes.
- The use of disc brakes which provide shorter stopping distances and decrease the risk of thermal damage to wheels.
- The ability to effectuate a graduated release of the brakes due to a design feature of the brake equipment which permits more flexibility and more forgiving train control.
- The ability to cut out brakes on a per-axle or per-truck basis rather than a per car basis, thus permitting greater use of those brakes that are operable.
- The use of a pressure-maintaining feature on each car which continuously maintains the air pressure in the brake system, thereby compensating for any leakage in the trainline and preventing a total loss of air in the brake system.

- The use of a separate trainline from the locomotive main reservoir to continuously charge supply reservoirs independent of the brake pipe train line.

- Brake ratios that are 2½ times greater than the brake ratios of loaded freight cars.

Although some of the technologies noted above have existed for several decades, most of the technologies were not in wide spread use until after 1980. Furthermore, most of the noted technological advances just started to be integrated into one efficient and reliable braking system within the last decade. In addition to the technological advances, commuter and intercity passenger train operations have experienced considerable growth in the last 15 years necessitating the need to provide more reliable and efficient service to the riding public. Since 1980, the number of commuter operations providing rail service has almost doubled and the number of daily passengers serviced by passenger operations has more than doubled over the same time period. Furthermore, commuter and intercity passenger train operations conduct more frequent single car tests, COT&S, and maintenance of the braking systems than is generally the practice in the freight industry. Consequently, the technology incorporated into the brake equipment used in today's commuter and intercity passenger train operations has increased the reliability of the braking system and permits the safe operation of the equipment for extended distances even though a portion of the braking system may be inoperative or defective.

In the face of these technological advances, FRA believes it is appropriate to utilize the authority granted by 49 U.S.C. 20306 and exempt commuter and intercity passenger train operations from the specific restriction contained in 49 U.S.C. 20303(a) requiring the movement of equipment with defective or insecure brakes to the nearest location where the necessary repairs could be made and proposes various restrictions on the movement of this type of equipment which FRA believes are more conducive to safe operations.

In utilizing the authority granted pursuant to 49 U.S.C. 20306, the Secretary is required to make "findings based on evidence developed at a hearing," unless there is "an agreement between national railroad labor representatives and the developer of the new equipment or technology." FRA is confident that, after notice and opportunity for public comment, oral and written, the record will support a finding that the proposed provisions are "in the public interest and consistent

with railroad safety," the basic test for waiving safety requirements issued under other, general provisions of the code. See 49 U.S.C. 20103(d). It should be noted that the exemption granted to these operations does not include an exemption from 49 U.S.C. 20303(c), which contains the liability provisions attendant with the movement equipment with defective or insecure safety appliances, including power brakes. Consequently, the liability provisions contained in 49 U.S.C. 20303(c) will be applicable to a railroad when hauling equipment with defective or insecure power brakes pursuant to the requirements proposed by FRA in this notice.

FRA also proposes to exempt commuter and intercity passenger train operations from its longstanding interpretation, based on 49 U.S.C. 20302(a)(5)(B) and 49 CFR 232.1 noted above, prohibiting the movement of a train if more than 15 percent of the cars in the train have defective, insecure, or inoperative brakes. As discussed previously, such a limitation is overly burdensome and has the potential of creating safety hazards due to the short length of the trains commonly operated in commuter and intercity passenger service.

Based on the preceding discussions, FRA proposes various restrictions on the movement of vehicles with defective brake equipment which allow commuter and intercity passenger train operations to take advantage of the efficiencies created due to the advanced braking systems these operations employ as well as the improvements made in brake equipment over the years, while ensuring if not enhancing the safety of the traveling public. FRA proposes to permit trains to be operated with up to 50 percent inoperative brakes to the next forward passenger station or terminal based on the percentage of operative brakes, which may result in movements past locations where the necessary repairs could be made. However, to ensure the safety of these trains with lower percentages of operative brakes, FRA also proposes various speed restrictions and other operating restrictions, based on the percentage of operative brakes. FRA believes that the proposed speed restrictions are very conservative and ensure a high level of safety. In fact, test data establish that with the proposed speed restrictions the stopping distances of those trains with lower percentages of operative brakes are shorter than if the trains were operating at normal speed and had 100 percent operative brakes. Consequently, FRA believes that the proposed approach to the movement of

equipment with defective brakes not only enhances the overall safety of train operations but benefits both the railroads, by providing operational flexibility, and the traveling public, by permitting them to get to their destinations in a more expedient and safe fashion. (The proposed restrictions on the movement of equipment with defective brakes are discussed in detail in the section-by-section analysis below.)

Although FRA proposes to exempt all commuter and passenger operations from the specific statutory requirement contained in 49 U.S.C. 20303(a), it should be noted that in reality the exemption being proposed is fairly limited. In FRA's view, many of the proposed methods for moving defective equipment are consistent, if not in accordance, with the current statutory requirement. For example, FRA proposes to permit a passenger train with 50–75 percent operative brakes to be moved at reduced speed to the next forward passenger station. Although the percentage of operative brakes is lower than currently permitted by FRA's longstanding agency interpretation (which FRA believes is fully compensated for by the proposed speed restrictions), FRA believes that the movement of the defective equipment to the next passenger station is in accordance with the statutory requirement as the safety of the passengers must be considered in determining the nearest location where necessary repairs can be made. In addition, permitting passenger trains to continue to the next forward location where the necessary repairs can be performed is also consistent with the statutory requirement as such movement is necessary to ensure the safety of the traveling public by protecting them from the hazards incident to performing movements against the current of traffic. Furthermore, the proposed movement provisions related to long-distance intercity passenger trains and long-distance Tier II equipment are consistent with the current statutory requirements as the proposal permits the movement of defective brake equipment on these trains only to the next passenger station or the next repair location, with various speed restrictions depending on the percentage of operative brakes. Due to the unique technologies used on the brake systems of these operations and the unique operating environments, the facilities and personnel necessary to conduct proper repairs on this equipment are somewhat specialized and limited.

EXHIBIT 2006- 242

DEPOSITION MALO EXHIBIT 7

Thus, FRA proposes to require the operators of these trains to designate the locations where repairs will be made to the equipment.

Some of the members of the Working Group, particularly those representing labor organizations, expressed concern that any alteration of the movement for repair provisions made in the context of commuter and intercity passenger train operations may have a spillover effect into the freight industry. FRA wishes to make clear that it has no intention, at this time, of exempting freight operations from the requirements relating to the movement of defective equipment contained in 49 U.S.C. 20303. As noted above, many of the advanced brake system technologies currently used in passenger service are not used in the freight context. Furthermore, even if freight operations were to make similar advances in the braking equipment they employ, this development on the freight side may not create the efficiencies created in the passenger train context since the operating environments of freight trains and passenger trains differ significantly. Finally, the special safety considerations relative to passengers are not present in freight operations.

Structural Standards

To help ensure the survivability of a passenger train accident, FRA is proposing comprehensive, minimum safety standards for the structural design of rail passenger equipment. Under current regulations, MU locomotives must comply with minimum structural design requirements, *see* 49 CFR 229.141; however, no comparable set of Federal structural design requirements apply to other forms of passenger equipment. Moreover, FRA believes that existing structural design requirements for MU locomotives should be revised, particularly those concerning MU locomotives operating in trains having a total empty weight of less than 600,000 pounds, *see* § 229.141(b), because train operation has significantly changed since these requirements were first promulgated.

The requirements contained in the proposed rule for the structural design of Tier I and Tier II equipment are specified below in the section-by-section analysis. These requirements include safety standards for the following:

- Anti-climbers—to prevent vehicles in a passenger train from overriding or telescoping into one another;
- Collision posts—to protect against the crushing of a passenger vehicle's occupied areas in the event of a collision or derailment;

- Corner posts—to protect passenger vehicles in corner-to-corner collisions and impacts with objects intruding upon the clearance envelope;
- Rollover strength—to prevent significant deformation of the normally occupied spaces of a vehicle in the event it rolls onto its side or roof;
- Side impact strength—to resist penetration of a passenger vehicle's side structure from a side collision with an object such as a highway vehicle or a freight car; and
- Truck to car body attachment—to prevent separation of trucks from car bodies during collisions or derailments.

Corner Posts

Requirements concerning corner posts on rail passenger equipment have been the subject of an NTSB safety recommendation. Following the January 18, 1993, NICTD corner-to-corner train collision in Gary, Indiana, the NTSB expressed concern about the adequacy of the corner post structure in self-propelled passenger cars (MU locomotives) that allows significant inward car body intrusion and subsequent serious injuries and fatalities in a corner-to-corner collision. The NTSB noted that, while MU locomotives must comply with Federal structural design requirements which include providing for the protection of vulnerable areas of the car body in a head-on collision, Federal regulations do not address structural requirements for corner posts which protect the car body in a corner-to-corner collision. Based on its investigation, the NTSB recommended that FRA:

In cooperation with the Federal Transit Administration and the American Public Transit Association, study the feasibility of providing car body corner post structures on all self-propelled passenger cars and control cab locomotives to afford occupant protection during corner collisions. If feasible, amend the locomotive safety standards accordingly. (Class II, Priority Action) (R-93-24)

The Working Group has recommended that minimum corner post structural design requirements be proposed for both locomotives and rail cars designed to carry passengers, regardless whether the rail cars are self-propelled or have control compartments. FRA is proposing such a requirement in this rule and thereby extending the scope of the NTSB's safety recommendation, which is expressly limited to self-propelled rail cars. This action recognizes passenger exposure in accidents such as the one in Lugoff, South Carolina, on July 31, 1991. There, eight passengers were killed following incursion of a freight car into

the side of two Amtrak coaches beginning at the corner of each car.

For cab cars, material improvements in actual end structure design with respect to corner posts must await completion of further research. Research completed to date indicates that improvements in strength alone will not prevent casualties in accidents at higher closing speeds such as those in the Silver Spring, Maryland, and Secaucus, New Jersey, accidents.

Fuel Tank Standards

Locomotive fuel tanks are vulnerable to damage from collisions, derailments, and debris on the roadbed due to their location on the underframe and between the trucks of locomotives. Damage to the tank frequently results in spilled fuel, creating the safety problem of an increased risk of fire and the environmental problem of cleanup and restoration of the spill site. Although 49 CFR 229.71 does require a minimum clearance of 2.5 inches between the top of the rail and the lowest point on a part or appliance of a locomotive, which includes fuel tanks, FRA regulations do not address the safety of fuel tanks in particular.

In 1992, the NTSB issued a report identifying concerns regarding safety problems caused by diesel fuel spills from ruptured or punctured locomotive fuel tanks. Entitled "Locomotive Fuel Tank Integrity Safety Study," the NTSB report cited in particular a collision involving an Amtrak train and an MBTA commuter train on December 12, 1990, as both trains were entering a station in Boston, Massachusetts. (NTSB Safety Study-92/04.) Fuel spilled from a tank which had separated from an Amtrak locomotive during the collision. The fuel ignited. Smoke and fumes from the burning diesel fuel filled the tunnel, increasing the hazard level in the post-crash phase of the accident, and hindering emergency response activity. As a result of the safety study, the NTSB made several safety recommendations to FRA, including in particular that FRA:

Conduct, in conjunction with the Association of American Railroads, General Electric, and the Electro-Motive Division of General Motors, research to determine if the locomotive fuel tank can be improved to withstand forces encountered in the more severe locomotive derailment accidents or if fuel containment can be improved to reduce the rate of fuel leakage and fuel ignition. Consideration should be given to crash or simulated testing and evaluation of recent and proposed design modifications to the locomotive fuel tank, including increasing the structural strength of end and side wall plates, raising the tank higher above the rail, and using internal tank bladders and foam inserts. (Class II, Priority Action) (R-92-10)

Establish, if warranted, minimum performance standards for locomotive fuel tanks based on the research called for in recommendation R-92-10. (Class III, Longer Term Action) (R-92-11)

The NTSB reiterated Safety Recommendation R-92-10 in a letter to FRA dated August 28, 1997, conveying the NTSB's final safety recommendations arising from the February 16, 1996, collision between a MARC commuter train and an Amtrak passenger train. During the collision, the fuel tank on the lead Amtrak locomotive ruptured catastrophically. The fuel sprayed into the exposed interior of the MARC cab control car and ignited, engulfing the car. (Letter at 12.)

As explained in FRA's report to Congress on locomotive crashworthiness and working conditions, FRA believes that fuel tank design has a direct impact on safety. Minimum performance standards for locomotive fuel tanks should be included in Federal safety regulations. Accordingly, FRA is proposing that AAR Recommended Practice RP-506 be incorporated into § 238.223 of the proposed rule for external fuel tanks on Tier I passenger locomotives. FRA believes that RP-506 represents a good interim safety standard for Tier I passenger locomotives. Further, FRA is proposing more demanding fuel tank safety standards for Tier II passenger equipment in § 238.423 of the proposed rule. Additionally, it is anticipated that RSAC will address the safety of locomotive fuel tanks used on freight equipment, thereby furthering the safety of rail passenger trains which operate commingled with freight trains.

FRA invites comments whether the proposed rule should also require that locomotive fuel tanks be compartmentalized. The Working Group specifically discussed requiring whether the interior of fuel tanks be divided into a minimum of four separate compartments so that a penetration in the exterior skin of any one compartment results in loss of fuel only from that compartment. The Working Group recommended that such a requirement be addressed in the second phase of the rulemaking, to allow for additional research to remedy fuel feeding disruptions that may result from the compartmentalization of fuel tanks. Commenters are therefore requested to provide the results of specific research and operating experience showing how compartmentalization can be practically accomplished. Commenters are also asked to explain why the issue of compartmentalization should or should not be addressed in the final rule of this first phase of the rulemaking.

Rim-Stamped Straight-Plate Wheels

On January 13, 1994, a Ringling Bros. and Barnum & Bailey Circus (Ringling Bros.) train operating on CSXT trackage derailed while passing through Lakeland, Florida. Two circus employees were killed, and 15 received minor injuries. The NTSB determined that the probable cause of the accident was the fatigue failure of a thermally damaged straight-plate wheel due to fatigue cracking that initiated at a stress raiser associated with a stamped character on the wheel rim. (NTSB/RAR-95/01.)

Noting that tread braking is a significant source of wheel overheating and thermal damage; straight-plate wheels are vulnerable to thermal damage; and rim stamping provides a stress concentration for crack initiation, the NTSB recommends as a result of its investigation that FRA "[p]rohibit the replacement of wheels on any tread-braked passenger railroad car with rim-stamped straight-plate wheels." (Class II, Priority Action) (R-95-1).

FRA agrees that rim stamping of straight-plate wheels can lead to wheel failure when subjected to heat from tread braking. Rim-stamping was banned by the AAR in 1978, and FRA does not believe that rim-stamped straight-plate wheels are in use on Amtrak or the nation's commuter railroads. Nevertheless, in the event such wheels are in fact in use, FRA proposes to prohibit the use of rim-stamped straight-plate wheels on all equipment, whether tread-braked or not, used in intercity passenger or commuter service as of January 1, 1998. In a letter to the NTSB dated February 21, 1995, Ringling Bros. itself announced that it has removed all rim-stamped straight-plate wheels on tread-braked passenger cars from its circus trains. (Appendix D, NTSB/RAR-95/01.)

At this time, FRA is not proposing to prohibit the use of rim-stamped straight-plate wheels on private passenger cars hauled in intercity passenger or commuter trains. Private passenger cars are generally not highly utilized in comparison to intercity passenger or commuter equipment. According to a comment received from the AAPRCO, the average private car, qualified to operate on Amtrak, probably operates less than 4,000 miles per year, and a few may exceed 50,000 miles per year. Further, in a letter to the NTSB dated December 2, 1994, Amtrak stated that it only operates private cars that are registered with Amtrak and are subject to a regular inspection by Amtrak-approved inspectors. Amtrak observed that it "has not experienced any

problems on the private cars that operate on Amtrak trains with wheels that are rim-stamped." (Appendix E, NTSB/RAR-95/01.)

However, FRA is requiring that rim-stamped straight-plate wheels not be used as a replacement wheelset on a private car. As part of this rulemaking, FRA may further address the use of rim-stamped straight-plate wheels on private cars hauled in intercity passenger or commuter trains.

Fire Safety

In 1984, FRA published guidelines recommending testing methods and performance criteria for the flammability, smoke emission, and fire endurance characteristics for categories and functions of materials to be used in the construction of new or rebuilt rail passenger equipment. See 49 FR 33076, Aug. 20, 1984; 49 FR 44582, Nov. 7, 1984. The guidelines mirrored fire safety guidelines developed by the Urban Mass Transit Administration (UMTA) of DOT (now the Federal Transit Administration).

The intent of the guidelines is to prevent fire ignition and to maximize the time available for passenger evacuation if fire does occur. FRA later reissued the guidelines in 1989 to update the recommended testing methods. See 54 FR 1837, Jan. 17, 1989. Testing methods cited in the current FRA guidelines include those of the American Society of Testing and Materials (ASTM) and the Federal Aviation Administration (FAA). In particular, the ASTM and FAA testing methods provide a useful screening device to identify materials that are especially hazardous.

FRA sought comments in the ANPRM on the need for more thorough guidelines or Federal regulations concerning fire safety (61 FR 30696). FRA noted that fire resistance, detection, and suppression technologies have all advanced since the guidelines were first published. In addition, FRA explained that a trend toward a systems approach to fire safety is evident in most countries with modern rail systems. In response, the National Fire Protection Association (NFPA) commented that perhaps more thorough guidelines are needed, or at least should be evaluated. A private citizen also responded that, at a minimum, guidelines which are more in depth and "well thought out"—based on current system safety procedures and available fire safety engineering techniques—are needed to address the fire safety concerns FRA raised in the ANPRM. The commenter noted in particular that Federal maintenance standards related

to fire safety are necessary to ensure that materials carefully qualified for use in rail passenger vehicles because of their fire safety characteristics are not replaced with either substandard materials or materials whose origin and fire performance cannot be determined.

The proposed rule addresses fire safety by making FRA's fire safety guidelines mandatory for the construction of new passenger equipment as well as the refurbishing of existing equipment. In addition, the proposed rule would require that fire safety be furthered through a fire protection plan and program carried out by each operating railroad. This effort would include conducting a fire safety analysis of existing passenger equipment and taking appropriate action to reduce the risk of personal injuries. In the second phase of this rulemaking, FRA anticipates improving upon the safety standards contained in the existing fire safety guidelines through ongoing research.

Currently, the National Institute of Standards and Technology (NIST) is conducting research under the direction of FRA and the Volpe Center involving the fire safety of rail passenger vehicles. The NIST project, scheduled for completion in 1998, will investigate the use of alternative fire testing methods and computer hazard assessment models to identify and evaluate approaches to passenger train fire safety. The evaluation will examine the effects and tradeoffs of passenger car and system design (including materials), fire detection and suppression systems, and passenger egress time. A peer review committee has been established to provide project guidance and review interim results and reports. The committee includes representatives from FRA, the Volpe Center, the NFPA, builders of rail passenger vehicles, producers of materials, Amtrak and commuter railroads, and testing laboratories.

In the first phase of the NIST project, selected materials which satisfy the testing methods referenced in FRA's fire safety guidelines will be evaluated using a different testing instrument, the ASTM 1354 Cone Calorimeter. The Cone Calorimeter provides a measurement of heat release rate (the amount of energy that a material produces while burning), specimen mass loss, smoke production, and combustion gases. For a given confined space such as a rail car interior, the air temperature and risk of harm to passengers are increased as the heat release rate increases. As a result, even if passengers do not come in direct contact with a fire, they may likely be injured from the high temperatures,

high heat fluxes, and large amounts of toxic gases emitted by materials involved in the fire.

The NIST testing will help develop performance criteria for materials using the Cone Calorimeter in a context similar to that provided in the FRA fire safety guidelines. In addition, unlike data derived from the testing methods referenced in the current FRA guidelines, heat release rate and other measurements obtained from the Cone Calorimeter can be used in a fire modeling methodology to evaluate the contribution of materials to the overall fire safety of a passenger train. Data gathered from the NIST testing will be used in the second phase of the project to perform a fire hazard analysis of selected passenger train fire scenarios. The analysis will employ computer modeling to assess the impact on passenger train fire safety for a range of construction materials and system design. In the final phase of the project, selected real-scale proof testing of assemblies representing rail passenger equipment will be performed to verify the bench-scale (small-scale) criteria and hazard analysis studies in actual end use configurations. This research effort thus follows upon FRA-sponsored studies by the National Bureau of Standards in 1984 and the NIST in 1993 which noted among their findings that the performance of individual components of a rail passenger car in a real-world fire environment may be different from that experienced in bench-scale tests due to vehicle geometry and materials interaction.²

The NFPA publishes a standard (NFPA 130) covering fire protection requirements for fixed guideway transit systems and for life safety from fire in transit stations, trainways, vehicles, and outdoor maintenance and storage areas. (A copy of the 1995 edition of this standard has been placed in the public docket for this rulemaking.) However, this standard does not apply to passenger railroad systems including those that provide commuter service (NFPA 130 1-1.2). An APTA representative on the Working Group who is also an NFPA member has initiated an NFPA-sponsored task force to revise the scope of NFPA 130 to cover all passenger rail transportation systems, including intercity and

² "Fire Tests of Amtrak Passenger Rail Vehicle Interiors." (NBS Technical Note 1193, May 1984); "Fire Safety of Passenger Trains: A Review of U.S. and Foreign Approaches." (DOT/FRA/ORD-93/23-DOT-VNTSC-FRA-93-26, December, 1993). The 1993 report is available to the public through the National Technical Information Service, Springfield, VA 22161. A copy of both reports have been placed in the public docket for this rulemaking.

commuter rail, and revise other provisions as necessary. (Copies of the correspondence concerning the establishment of this task force have also been placed in the public docket.) FRA and the Working Group will evaluate the results of this effort for application to this rulemaking.

Safety Glazing Standards

Existing regulations found in 49 CFR part 223 provide minimum requirements for glazing materials in order to protect railroad passengers and employees from injury as a result of objects striking the windows of locomotives, cabooses, and passenger cars. Noting some possible concerns with these requirements, FRA sought comment on whether these standards should be revised and requested information on any glazing-related injuries to passenger train occupants (61 FR 30696).

The Sierracin/Sylmar Corporation (Sierracin) commented that rail glazing meeting much higher impact and ballistic requirements is currently available, economically viable, and in fact in use by a few rail agencies (mass transit and commuter rail) here in the United States. Among its observations in particular, Sierracin noted that the strength of the glazing frame could quite easily be tested. Further, it explained that from its experience as a glazing manufacturer it is aware of very few ballistic attacks on trains, and such attacks have been limited to the side windows of locomotives or coach cars or both—not to end-facing windows. In addition, Sierracin pointed out that since the impact energy of an object is a function of velocity, an object's destructive capability increases as the speed of the surface it impacts increases.

FRA believes that existing safety glazing requirements have largely proven effective in passenger service at speeds up to 125 mph. In fact, FRA is concerned that less stringent requirements would create vulnerability to objects thrown at trains as well as the risk of ejection of passengers during train derailments. Because the safety glazing standards do not address the performance of the frame which attaches the glazing to the car body, FRA is proposing frame performance requirements for all passenger equipment. Moreover, FRA believes that more stringent glazing requirements are necessary on passenger equipment operating at speeds greater than 125 mph because of the increased destructive potential of an object impacting equipment operating at such speeds. Additionally, improved marking

and periodic inspection of emergency windows are being addressed in FRA's emergency preparedness rulemaking.

Train Interior Safety Features

A review of the accident/incident data, related to fatalities and injuries on passenger trains for the period of 1972 to 1973, indicates that collapse of the equipment structure and the loss of sufficient space for the passengers to ride out the collision is the principal cause of fatality in train accidents, resulting in approximately 63 percent of the fatalities and 27 percent of the serious injuries. Fire and post-collision conditions result in 30 percent of the fatalities and 16 percent of the serious injuries. Thus, collapse of the equipment structure, fire, and post-collision conditions account for 93 percent of the fatalities and 43 percent of the serious injuries. To address these major causes of fatalities and injuries, FRA is proposing comprehensive requirements related to structural design, fire protection, and emergency exits. As discussed above, FRA believes these proposed requirements will aid in reducing the number of fatalities and injuries by minimizing the collapse of equipment, reducing the likelihood of fire, and ensuring accessible and operable emergency exits.

Prior research also indicates, however, that passengers striking interior objects in trains, principally during collisions and derailments, accounts for 57 percent of the serious injuries and 7 percent of the fatalities occurring on passenger trains.³ Therefore, as an initial measure to reduce these numbers, FRA proposals include requiring that:

- Passenger seats and other interior fittings be securely attached to the car body;
- Interior fittings in a passenger car be recessed or flush-mounted;
- Overhead storage racks provide restraint for stowed articles; and
- Sharp edges be padded or otherwise avoided.

Overall, FRA's proposed requirements rely on "compartmentalization" or "passive restraints" (i.e., requiring no action to be taken on the part of the occupant) as a passenger protection strategy. The proposed requirements are based on the current available research, discussed in detail below, which indicates that during a collision the interior environment of a passenger coach is substantially less hostile than the interiors of automobiles and aircraft.

³Rail Safety/Equipment Crashworthiness," M.J. Reiley, R.H. Jines, & A.E. Tanner. (FRA/ORD-77/73, Vol. I, July 1978)."

In fact, current research indicates that the interior of a typical intercity passenger coach without active restraints provides a level of protection to the occupants that is at least as high as that provided to automobile and transport aircraft passengers with active restraints.

Some research indicates that there may be a potential for even a greater level of passenger protection if lap belts and shoulder harnesses are utilized on passenger trains. In fact, FRA is proposing that lap belts and shoulder harnesses be required in the cab of a Tier II train, as recommended by the Tier II Equipment Subgroup. Due to the high strength of the cab and its forward location near the expected point of impact in many different collision scenarios, decelerations experienced by crewmembers in the cab of Tier II trains may be high. Accordingly, members of the subgroup believed that restraints for the crewmembers could provide a significant benefit. FRA requests information and comment from interested parties as to whether there is any existing research or experience which would justify proposing active seat restraints in the current stage of this rulemaking. However, FRA believes more research is necessary in this area in order to determine the feasibility and effectiveness of such active restraints as well as the impact on seat design and strength. Although FRA currently proposes a passenger protection strategy based on compartmentalization, FRA will be undertaking an aggressive research and testing program to determine the feasibility and effectiveness of active restraints such as lap belts and shoulder harnesses. If this research indicates that these types of active restraints are a viable and feasible means of providing additional protection to the riding public, then FRA will propose the use of such restraints in the second NPRM on passenger equipment scheduled for development in 1998.

Discussion

The principal means of protecting occupants during accidents include "friendly" ("delethalized") interior arrangements and occupant restraints, such as lap belts, shoulder harnesses and airbags. Occupant protection devices which require some action on the part of the occupant, such as buckling a seatbelt, are termed "active devices," while protection devices which require no action, such as automobile door-mounted shoulder harnesses and airbags, are termed "passive devices." Both active and passive occupant protection strategies

act to limit the decelerations and to distribute the loads imparted to occupants during an accident. Typical passenger protection strategies in automobiles include airbags, lap belts and shoulder harnesses, and friendly lower dashboard designs which limit thigh loads imparted during a collision. Typical passenger protection strategies in transport category aircraft, intended to protect passengers during accidents occurring during takeoff or landing, include seatbelts and friendly design of the seatback or bulkhead ahead of the occupant which limit the decelerations of the occupant's head.

The passenger protection devices incorporated into a vehicle must allow occupants to survive the deceleration of the volume within which they are contained. The decelerations of the occupant volume of an automobile in a collision can reach a peak of approximately 30 g's, while the decelerations of transport-category aircraft during a landing accident can reach 18 g's. In order to assure a high likelihood of survival for such high decelerations, the use of occupant restraints are required in automobiles and transport aircraft. The peak deceleration of passenger rail coach

equipment is 8 g's for a head on collision. Figure 1 shows the time histories of the occupant volume decelerations for a Ford Taurus colliding into a rigid barrier at 35 mph,⁴ a transport category aircraft during a landing accident,⁵ and a rail passenger coach during a train-to-train collision at 70 mph.⁶ During a collision, the interior of a passenger train is inherently a less hostile environment than those of an automobile or aircraft, owing to the relatively low deceleration of the occupant volume.

BILLING CODE 4910-06-P

Figure 1.

Typical Automobile, Transport Aircraft, and Passenger Rail Car Decelerations During a Collision

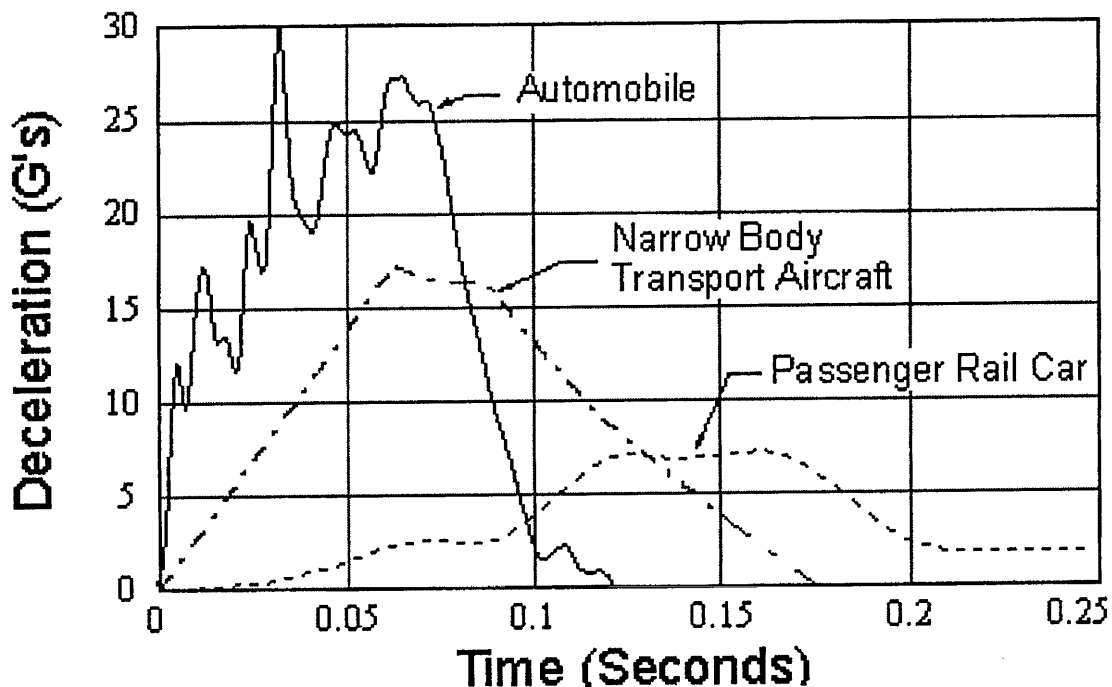

⁴ New Car Assessment Program Test #2312. DOT/NHTSA, 1996. A copy of this test has been placed in the public docket for this rulemaking.

⁵ The Effect of Aircraft Size on Cabin Floor Dynamic Pulses." G. Wittlin, L. Neri. (DOT/FAA/CT-49-01-1990-01-0246 is available to

the public through the National Technical Information Service, Springfield, VA 22161. A copy of the report has also been placed in the public docket for this rulemaking.

⁶ "Crashworthiness of Passenger Trains." (DOT-VNTSC-FRA-96-5, September 1996). The report

has not yet been published, but a copy of the report has been placed in the public docket for this rulemaking.

BILLING CODE 4910-06-C

Simulation studies of occupant impacts with interiors have been conducted in support of this rulemaking effort, and have been placed in the public docket for this rulemaking.⁷ Simulation results include detailed time-histories of occupant motions and the forces imparted to occupants during a collision. These motions and forces have been evaluated for the potential for fatality using the criteria employed by the National Highway Traffic Safety Administration (NHTSA) and the FAA in their regulatory requirements for passenger protection in automobiles and transport-category aircraft, respectively. The principal criteria employed by NHTSA and the FAA are the Head

Injury Criteria (HIC), which relate the deceleration of the occupant's head to the potential for fatality, and the Chest Deceleration, which relates the deceleration of the occupant's chest (heart) with the potential for fatality. The maximum limit prescribed by NHSTA and the FAA for the HIC is 1000, and 60 g's for Chest Deceleration. Passenger rail equipment interior configurations studied include rows of forward-facing seats without passenger restraints, with seat belts, and with seatbelts and shoulder harnesses. The seat design employed in these studies is a typical intercity passenger coach seat, for which the floor attachment is sufficient not to fail during the simulated collision. (The occupant

protection strategy in which occupant motion during the collision is restricted by fixed equipment such as seats and bulkheads is termed "compartmentalization.") Table 1 summarizes the results for passengers seated in the first coach of a locomotive-led consist, initially traveling at 70 mph, which collides head-on with a stationary locomotive-led consist. These data indicate that without restraints, the interior of a typical intercity passenger coach provides a level of protection to the occupants at least as high as that provided to automobile and transport aircraft passengers with restraints, while lap and shoulder belts provide the highest level of protection.

TABLE 1.—SELECTED RESULTS, INTERIOR SIMULATION STUDIES

	No restraint (compartmentalization)		Lap belt		Lap and shoulder belts		NHTSA and FAA Max. permitted values	
	HIC	Chest g's	HIC	Chest g's	HIC	Chest g's	HIC	Chest g's
50th percentile male, Seat ahead Upright	241	20	141	23	21	9	1000	60
50th percentile male, Seat ahead Reclined	401	36	1428-2089	26	21	9	1000	60

The data in Table 1 indicate that lap belts alone result in a greater likelihood of fatal head injury for certain occupants if the seat ahead of the occupant is reclined. This is owing to the lap-belted occupant striking the top of the seatback ahead. Struck in this manner, the seat is stiff and the head deceleration is large, resulting in a high likelihood of head injury. The head of an unrestrained occupant will strike the rear of the seatback ahead of the occupant, along with the knees of the occupant. Struck in this manner, the seat is relatively soft, the impact forces are distributed over the occupant's body, and the decelerations experienced by the occupant are within survivable levels. The head on an occupant restrained by a lap belt and a shoulder harness will not strike an interior surface, and the deceleration of an occupant so restrained is relatively low. The motions of an unrestrained occupant, an occupant restrained by a lap belt, and an occupant restrained by a lap belt and a shoulder harness are sketched in Figure 2.

BILLING CODE 4910-06-P

⁷ "Evaluation of Selected Crashworthiness Strategies for Passenger Trains." D. Tyrell, K. Severson-Green, & B. Marquis. National Academy Press, Transportation Research Record No. 1989, July 1995; "Analysis of Occupant Protection

Strategies in Train Collisions." D. Tyrell, K. Severson, & B. Marquis. American Society of Mechanical Engineers, AMD-Vol. 210/BED-Vol. 30, pp. 539-557, 1995; "Crashworthiness Testing of Amtrak's Traditional Coach Seat." D. Tyrell K.

Severson. (DOT/FRA/ORD-96/08—DOT-VNTSC-FRA-96-11, October 1996); and "Crashworthiness of Passenger Trains." See note 6.

Figure 2.

Sketch of Occupant Motions: Unrestrained, with Lap Belt, and with Lap Belt and Shoulder Harness

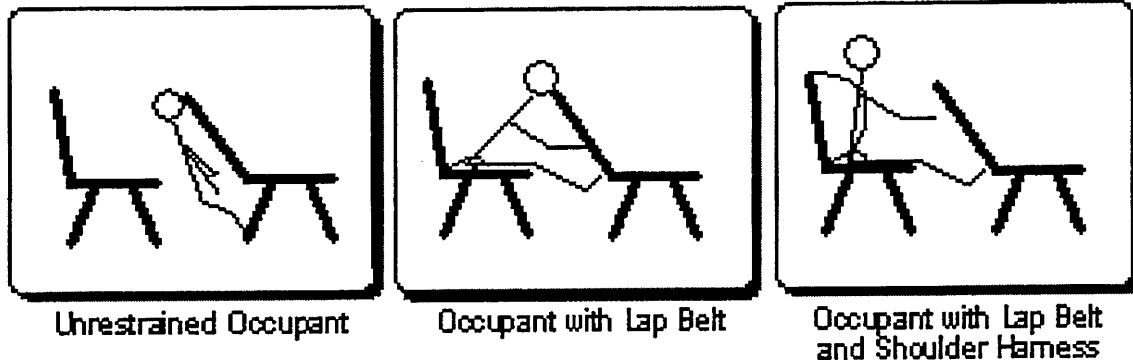

BILLING CODE 4910-06-C

The potential effectiveness of occupant restraints in protecting passengers has been inferred from available information on what types of injury occur during passenger train accidents and the equipment involved in causing these injuries. Available criteria which relate these forces and motions to the range of injuries resulting from rail passenger accidents are limited in number and reliability. For example, there is only one accepted criterion for evaluating back injury (an axial load criterion employed by the FAA) while there are many potential modes of back

injury, including twisting and excessive flexion. The two principal considerations in inferring the potential effectiveness are the likelihood that the occupant is in a seat and is able to use the restraint, and the potential that the type of injury is prone to prevention or reduction in severity with an occupant restraint.

Table 2 lists the types of injuries, their frequency of occurrence from 1972 to 1973 (see note 3), and the potential effectiveness of occupant restraints. The likely causes of back injury are the seats becoming unlocked and swiveling during an accident and standing

passengers subject to falling. Leg, knee, and thigh injuries are potentially caused by leg entrapment beneath the seat ahead of the occupant. Neck injuries are likely the result of "whiplash" effects of low seat backs during accidents. The potential effectiveness of occupant restraints can be inferred from the type of injury. For example, seat belts may reduce the occurrence and severity of back injury owing to the longitudinal decelerations from collisions, but may not reduce the occurrence and severity of back injury owing to the lateral accelerations associated with derailment or for a standing passenger falling.

TABLE 2.—INJURY TYPES, NUMBER OF OCCURRENCES, AND POTENTIAL EFFECTIVENESS OF OCCUPANT RESTRAINT

Injury type	Number of Occurrences, 1972-73	Potential/effectiveness		
		No Restraints (Compartmentalization)	Lap Belts	Lap belts and shoulder harnesses
Back	195	Medium	Medium	High
Leg/Knee/Thigh	140	Low	Medium	Medium
Neck	126	Medium	Low	Medium
Head	94	Medium	Low	High
Arm/Hand	89	Low	Low	Low
Chest	64	Medium	Medium	Medium
Shoulder	61	Medium	Medium	Medium
Hip/Pelvis	40	Medium	High	High
Face/Nose	38	Medium	Low	High
Foot/Ankle	27	Low	Medium	Medium
Abdomen	19	Medium	Medium	Medium
Side	15	Medium	Medium	High

Table 3 lists the equipment involved in injury over this same period (see note 3). The likelihood that an occupant was in a seat immediately prior to the injury can be inferred from the type of equipment. For example, the potential effectiveness of occupant restraints protecting occupants from injury with food service and lavatory equipment—the most likely equipment to be involved with injury—is low because such equipment is not located near passenger coach seats. Appropriate measures to assure that such equipment is "friendly" during a collision may potentially reduce the severity of injuries associated with food service and lavatory equipment. In fact, since the time of the study, Amtrak has taken significant steps to secure food service equipment and provides for better retention of luggage in overhead storage racks. Further, lavatory design has also been improved in the newer generations of Amtrak equipment.

TABLE 3.—EQUIPMENT INVOLVED IN INJURY, FREQUENCY OF OCCURRENCE, AND POTENTIAL EFFECTIVENESS OF OCCUPANT RESTRAINT

Equipment involved in injury	Frequency of occurrence (percent)	Potential effectiveness		
		No restraints (compartmentalization)	Lap belts	Lap belts and shoulder harnesses
Food Service and Lavatory Equipment	27.5	Medium	Low	Low
Bulkheads, Doors, Window Frames	20	Medium	Low	Low
Seats	16	High	High	High
Floor	10.2	Medium	Medium	Medium
Window Glass	10.2	Medium	Medium	Medium
Tables Counters	7.2	Low	Low	Low
Hand Rail	2.9	Low	Low	Low
Entrance Platform	2.9	Low	Low	Low
Luggage	1.5	Low	Low	Low
Cabinets	1.5	Low	Low	Low

Conclusions from the research conducted to date on passenger protection in train collisions are that lap belts alone may potentially increase fatalities in train collisions; compartmentalization can provide a level of protection for rail passengers at least as effective as that provided by current regulations for automobile and transport-category aircraft passengers; and that lap belts and shoulder restraints provide the highest level of occupant protection of those protection strategies studied.

Current FRA research plans include efforts for developing the means of implementing seat belts and shoulder restraints in intercity and commuter passenger rail equipment and efforts for optimizing compartmentalization for a wide range of occupant sizes, from infants to large adults, and a wide range of interior configurations, including those of food service cars and lavatories in addition to coach car seating configurations. Issues to be addressed in research on implementing seat belts and shoulder restraints include:

- The development of a seat structure design with sufficient integrity to sustain the loads imparted by the restraints during collisions;
- The potential for increased injury of unrestrained occupants striking such strengthened seatbacks and the hard points necessary for lap and shoulder belt securement;
- The potential for increased injury to occupants who misuse the seat and shoulder belts (e.g., placement of the shoulder belt behind the occupant).

The development of mechanisms for adjusting the height location of the shoulder restraint to prevent strangulation of occupants of small stature, including children;

- The overall effectiveness in reducing injury owing to occupant impacts with the interior; and

- The manufacturing costs for a seat which can support the loads imparted by the restraints during collisions.

Although FRA's research and development budget is somewhat limited, FRA is committed to completing the following items within approximately the next 12 months:

- Preliminary cost/benefit analysis on lap belts and shoulder harnesses;
- Preliminary hazard analysis; and
- Preliminary qualitative engineering feasibility work on new seat and belt designs, including cost estimates.

The results of this research will be followed by a final cost/benefit review and will be available when FRA begins the development of the second NPRM on passenger equipment standards.

Based on current research results, the proposed interior passenger protection requirements for Tier I and II passenger equipment rely on compartmentalization as a passenger protection strategy. Research results indicate that during a collision the interior environment of a passenger coach is substantially less hostile than the interiors of automobiles and aircraft. Owing to this lower hostility of the passenger collision environment, the interior of a typical intercity passenger coach can provide a level of protection to passengers without restraints at least as effective in preventing fatality as the protection provided to automobile and transport aircraft passengers with restraints. Such a strategy has the benefits of being passive, requiring no action to be taken on the part of the occupants, of being effective for a range of occupant sizes, and potentially being effective in a wide range of interior configurations. If the results of ongoing research indicate that lap belts and shoulder restraints can provide a greater level of protection for passengers than compartmentalization, while being cost-effective, then FRA will consider

requiring passenger restraints in the second NPRM.

Crash Energy Management

FRA is proposing that Tier II equipment be designed with a crash energy management system. Crash energy management is an equipment design technique to provide a controlled deformation and collapse of designated sections of the unoccupied volumes of a passenger train to absorb the energy from a collision. This allows collision energy to dissipate before any structural damage occurs to the occupied volumes of a passenger train and reduces the decelerations experienced by passengers and crewmembers in a collision, thereby mitigating the force of any collisions with objects in a train's interior, such as seats.

In a report prepared by the Volpe Center, the crash energy management approach was found to offer significant safety benefits.⁸ For example, the Volpe Center report found the crash energy management approach significantly more effective in preserving occupant volume in a head-on collision at a relative speed above 70 mph between two trains propelled by power cars (locomotives) than when the trains did not employ such an approach. Moreover, for the full range of collision speeds, the crash energy management design provided a significantly gentler initial deceleration of the passenger train occupants than when the trains did not employ such an approach. Further, the crash energy management designed power car train is more compatible with existing equipment. It serves as a softer collision surface to a conventionally designed train owing to the collision energy absorbed as the

⁸ "Crashworthiness of Passenger Trains." (DOT-VNTSC-FRA-96-5, September 1996). See Note 6.

unoccupied volumes of the power car train intentionally crush.

Emergency Systems

In addition to the proposed requirements concerning emergency egress and access discussed above, FRA is considering and proposing other requirements to mitigate harm to passenger train occupants in emergency situations.

Emergency Lighting

In a passenger train emergency, inadequate lighting may make it difficult or impossible to read emergency information, to locate doors and emergency exits, and to move about within the train's interior. Rapid egress from the passenger train may be inhibited, and rescue efforts hampered. Further, a private citizen commented in response to the ANPRM that passengers can be very frightened when a train's head-end power shuts down at night or in a darkened station, and there is no onboard emergency lighting for the passengers' security. Accordingly, the proposed rule requires in § 238.123 that all new or rebuilt passenger equipment be equipped with an emergency lighting system. FRA is also considering requiring that auxiliary portable lighting be available for assistance in a passenger train emergency. FRA may prescribe requirements for such lighting in either the final rule of this rulemaking or in the final rule of FRA's complementary rulemaking on passenger train emergency preparedness.

Emergency Communication: To the Train Control Center

FRA is considering requirements for emergency communication equipment on passenger trains. In Working Group discussions, the UTU emphasized that passenger trains should be equipped with both a primary and a redundant means to communicate with a railroad control center. The UTU and BRC also stressed that both means of communication should be required to operate properly before a passenger train is dispatched.

The ability to communicate in an emergency is important for all trains—freight and passenger. For example, because passenger trains operate commingled with freight trains, the ability of a freight train crew to notify a railroad control center of an emergency involving its train may prevent a collision with an oncoming passenger train. As noted above, FRA is currently engaged in revising the Radio Standards and Procedures in 49 CFR part 220 through the Railroad Communications Working Group

established under the RSAC. Although FRA anticipates that this separate effort will establish minimum safety requirements with respect to communications equipment for all train service, it should be noted that intercity passenger and commuter railroads already make extensive provision for ensuring communication capabilities during emergencies.

Emergency Communication: Within the Train

FRA is proposing in § 238.437 that Tier II passenger trains be equipped with a means of emergency communication throughout the train. This will enable crewmembers to provide passengers with information and instructions in an emergency.

FRA has decided to limit this proposal to Tier II passenger trains, however, because such trains are intended to operate as a fixed unit, unlike Tier I passenger trains. Whereas an emergency system to communicate throughout the train may be more easily provided for a train which remains as a fixed unit, the interchangeability of passenger cars and locomotives raises practical considerations about the compatibility of communications equipment in a Tier I passenger train. FRA will seek to address these considerations and further examine requirements concerning emergency communication within a Tier I train in the second phase of the development of passenger equipment safety standards.

Emergency Window Exits

As noted, under 49 CFR part 223 equipment designed to carry passengers must be equipped with a minimum of four emergency window exits which permit rapid and easy removal during a crisis. FRA is proposing in §§ 238.235 and 238.439 to strengthen this requirement by making certain, for example, that passenger cars be equipped with four window exits on each main level of each car. FRA is also proposing that each compartment in a sleeping car be equipped with at least one emergency window exit. Above all, the proposed rule requires that each emergency window exit be easily operable without requiring the use of any tool or other implement to facilitate passenger egress in an emergency.

FRA notes that Canadian passenger equipment typically contain more than four emergency window exits, and that MARC is requiring that at least half of all windows in each passenger car be available for use during an emergency. Commenters are requested to address the issue of whether the final rule

should require additional emergency window exits in a passenger car.

Commenters are also requested to address what size requirements for emergency window exits FRA should impose in the final rule. FRA is currently proposing that Tier I equipment have a minimum, unobstructed emergency window exit opening of 24 inches horizontally by 18 inches vertically, and that Tier II equipment have a minimum, unobstructed emergency window exit opening of 30 inches horizontally by 30 inches vertically. The Tier II Equipment Subgroup, including Amtrak, recommended the latter requirement for application to Tier II equipment. However, the full Working Group advised against imposing such a requirement on Tier I equipment. Although FRA would prefer that all emergency window exits afford the larger opening, the Tier I equipment proposal provides the minimum opening needed for a fully-equipped emergency response worker to gain access to the interior of a train, according to the NFPA.

Roof Hatches or Clearly Marked Structural Weak Points

In an emergency, roof hatch exits on railroad passenger equipment may facilitate the rapid egress of passengers. However, APTA and Amtrak have raised concerns about requiring such exits on passenger equipment. Allowing access to the roof of a passenger train can be particularly dangerous, especially when the train operates in electrified territory. As an alternative, passenger equipment could be designed with a clearly marked structural weak point in the roof to provide quick access for emergency personnel. Access to and egress from passenger equipment would be facilitated, without the risk of allowing passengers immediate access to the roof when no emergency is present.

As recommended by the Tier II Equipment Subgroup, the proposed rule requires in § 238.439 that Tier II equipment either be equipped with roof hatches or be designed with clearly marked structural weak points in the roof to permit quick access for properly equipped emergency personnel. The proposed rule does not contain such requirements for Tier I equipment, however. There was no consensus within the full Working Group to recommend that such requirements be included. FRA will consider such requirements for Tier I equipment in the second phase of the rulemaking, and the Working Group agreed to do so as well. FRA does believe that the safety of Tier

I passenger trains will still be significantly advanced by the other requirements for emergency egress and access contained in this proposed rule.

Additional Passenger Train Safety Issues

As detailed below in the section-by-section analysis, the proposed rule will also address additional passenger train safety issues including:

- Equipment (non-brake) inspection, testing, and maintenance;
- Suspension system safety;
- Operating cab controls;
- Safety appliances;
- Electrical system safety;
- Software and hardware safety, and
- Introduction of new technology.

Further, in consultation with the Working Group, FRA has identified issues to address in the second phase of this rulemaking which may lead FRA to propose additional standards for Tier I equipment in a future NPRM. Although certain issues have already been noted above, such as improvements in cab car end structure design, other issues include crash energy management requirements and increased side impact strength requirements for car bodies. FRA intends that the Working Group advise FRA as to which requirements make sense for application to Tier I equipment and which requirements already proposed in this NPRM should be strengthened. It is anticipated that any operational experience gained from the use of Tier II equipment will assist the Working Group in this effort.

June 1997 NTSB Safety Recommendations

On June 17, 1997, the NTSB announced a series of safety recommendations as a result of its investigation of the collision between MARC train 286 and Amtrak train 29 in Silver Spring, Maryland, on February 16, 1996. While its investigation was still ongoing, the NTSB issued an urgent safety recommendation (R-96-7) to FRA on March 12, 1996. As explained earlier in the preamble, FRA convened a joint meeting of the Passenger Equipment Safety Standards Working Group and the Passenger Train Emergency Preparedness Working Group on March 26, 1996, to discuss this recommendation and incorporate the Safety Board's initial findings into each working group's rulemaking, as appropriate. This urgent recommendation has been fully considered and is reflected in this NPRM as well as the NPRM on Passenger Train Emergency Preparedness that was published on February 24, 1997 (see 62 FR 8330).

Though the Safety Board has reiterated portions of its earlier, urgent recommendation, FRA has not yet had the opportunity to discuss with the Passenger Equipment Safety Standards Working Group the full array of June 1997 recommendations pertaining to passenger equipment safety. However, for the consideration of interested parties, FRA has set forth below for public comment the recent NTSB recommendations relevant to this rulemaking. In particular, the NTSB has recommended that FRA:

- Require all passenger cars to have easily accessible interior emergency quick-release mechanisms adjacent to exterior passageway doors and take appropriate emergency action to ensure corrective action until these measures are incorporated into minimum passenger car safety standards.
- Require all passenger cars to have either removable windows, kick panels, or other suitable means for emergency exiting through the interior and exterior passageway doors where the door could impede passengers exiting in an emergency and take appropriate emergency measures to ensure corrective action until these measures are incorporated into minimum passenger car safety standards.
- Issue interim standards for the use of luminescent or retro-reflective material or both to mark all interior and exterior emergency exits in all passenger cars as soon as possible and incorporate the interim standards into minimum passenger car safety standards.
- Require all passenger cars to contain reliable emergency lighting fixtures that are each fitted with a self-contained independent power source and incorporate the requirements into minimum passenger car safety standards.
- Provide promptly a prescribed inspection and test cycle to ensure the proper operation of all emergency exit windows as well as provide that the 180-day inspection and maintenance test cycle is prescribed in the final rule.
- Require that all exterior emergency door release mechanisms on passenger cars be functional before a passenger car is placed in revenue service, that the emergency door release mechanism be placed in a readily accessible position and marked for easy identification in emergencies and derailments, and that these requirements be incorporated into minimum passenger car safety standards.
- Require that a comprehensive inspection of all commuter passenger cars be performed to independently verify that the interior materials of these cars meet the expected performance

requirements for flammability and smoke emissions characteristics. FRA has specifically responded in § 238.105 (Fire protection program) of this NPRM to the Board's recent recommendation concerning the flammability and smoke emission characteristics of interior materials in existing passenger cars.

APTA Comments

As explained earlier in the preamble, under the authority of 49 U.S.C. 20133(d) FRA developed the proposed rule in consultation with a Working Group that included Amtrak, individual commuter railroads, and APTA, which represents the interests of commuter railroads in regulatory matters. On March 19, 1997, following the last full meeting of the Working Group, FRA sent a draft of the NPRM to Working Group members and advisors for their review and comment as to whether the rule inaccurately reflected the Working Group's recommendations in a significant way. By letter dated April 28, 1997, APTA requested a meeting with FRA to address its significant concerns about a number of substantive items in the NPRM, as well as the process used to develop the NPRM. A meeting took place on May 23, 1997, at which time APTA provided FRA with extensive written comments on the draft NPRM. These comments have been placed in the public docket for this rulemaking, along with a summary of the meeting. FRA has also included a number of APTA's comments in this NPRM for the consideration of interested parties, and FRA invites all interested parties to address APTA's comments while commenting on the proposed rule.

Section-by-Section Analysis

Amendments to 49 CFR Part 216

Part 216 currently authorizes certain FRA and participating State inspectors to issue Special Notices for Repair, under specified conditions, for freight cars with defects under the part 215, locomotives with defects under parts 229 or 230 or 49 U.S.C. chapter 207, and track with defects under part 213. The proposed revisions to part 216 would create a fourth category of Special Notices for Repair: for passenger equipment with defects under part 238. In summary, if the inspector determines that the noncomplying passenger equipment is "unsafe for further service" and issues the proposed Special Notice, it would require the railroad to take the passenger equipment out of service, to make repairs to bring the equipment into compliance with part 238, and to report the repairs to

FRA. The revisions would also make conforming changes to part 216 reflecting this new enforcement tool.

Finally, these proposed revisions include various technical amendments to update part 216 to reflect the following: (1) internal organizational changes within FRA; (2) the division of former part 230, Locomotive Inspection Regulations, into parts 229 and 230 and the redesignation of those portions of former part 230 related to non-steam locomotives as part 229, Railroad Locomotive Safety Standards; and (3) the repeal, reenactment without substantive change, and recodification of the Federal railroad safety laws in 1994. See 45 FR 21092, Mar. 31, 1980; Pub. L. 103-272, July 5, 1994.

Amendments to 49 CFR Parts 223, 229, 231, and 232

FRA proposes conforming changes to the applicability sections of FRA's Safety Glazing Standards, Railroad Locomotive Safety Standards, Railroad Safety Appliance Standards, and railroad power brakes and drawbars regulations that were necessitated by proposed provisions of new part 238. In the final rule, FRA may adjust the application of provisions in parts 215, 223, 229, 231, or 232, or possibly delete provisions in those parts, to avoid duplication of provisions in part 238. FRA has not proposed deletion of passenger train brake test and maintenance requirements from part 232 because proposed part 238 would not cover certain operations subject to part 232, e.g., tourist, historic, scenic, and excursion railroad operations on the general system. If any provision in parts 215, 223, 229, 231, or 232 is deleted in the final rule, FRA will revise the schedule of civil penalties for the affected part by removing the entry for the provision deleted. Because such penalty schedules are statements of policy, notice and comment are not required prior to their issuance. See 5 U.S.C. 553(b)(3)(A).

49 CFR Part 238

(APTA is concerned that the proposed record keeping and reporting requirements in subparts A-D are extensive and significantly exceed current railroad practice, without any corresponding safety benefit. Commenters are requested to address APTA's concern.)

Subpart A—General

§ 238.1 Purpose and scope.

Paragraph (a) states the purpose of the rule to be the prevention of accidents involving railroad passenger equipment and the mitigation of the consequences

of accidents involving railroad passenger equipment, to the extent such accidents cannot be prevented. Paragraph (b) states that these regulations provide minimum standards for the subjects addressed. Railroads and other persons subject to this part may adopt more stringent requirements, so long as they are not inconsistent with this part.

§ 238.3 Application. As a general matter, in paragraphs (a)(1) and (a)(2), FRA proposes that this rule apply to all railroads that operate intercity passenger train service on the general railroad system of transportation or provide commuter or other short-haul passenger train service in a metropolitan or suburban area; that is, the rule will apply to commuter or other short-haul service described in paragraph (a)(2) regardless of whether that service is connected to the general railroad system. A public authority that indirectly provides passenger train service by contracting out the actual operation to another railroad or independent contractor would be regulated by FRA as a railroad under the provisions of the proposed rule. Paragraph (a)(3), read in conjunction with paragraph (c)(1), means that rapid transit operations in an urban area that are connected to the general railroad system of transportation would also be covered by this part. Paragraph (b) makes explicit the liability imposed by statute, 49 U.S.C. 20303, on a railroad that owns track over which another railroad hauls or uses equipment with a power brake or safety appliance defect. Under paragraph (b), a railroad that permits operations over its trackage by passenger equipment subject to this part that does not comply with a power brake provision of this part or a safety appliance provision of this part is subject to the power brake and safety appliance provisions of this part with respect to such operations that it permits.

This section contains no explicit reference to private cars. Rather than addressing the scope of applicability of part 238 to private cars in this section, FRA has indicated in the particular substantive sections of the rule whether private cars are covered, according to the terms of those sections. FRA proposes to apply certain requirements of the rule to private cars that operate on railroads subject to this part. FRA has taken into account the burden imposed by requiring private car owners and operators to conform to the requirements of this part. Further, FRA recognizes that private cars are often hauled by railroads such as Amtrak and commuter railroads which often impose

their own safety requirements on the operation of the private cars. Accordingly, FRA intends to limit the application of the proposed rule only to those requirements necessary to ensure the safe operation of the passenger train that is hauling the private car. For instance, private cars will be subject to brake inspection, testing, and maintenance requirements.

The proposed rule is structured to apply to intercity and commuter service, but not to tourist, scenic, historic, and excursion operations. The term "tourist, scenic, historic, or excursion operations" is defined in § 238.5 to mean "railroad operations that carry passengers, often using antiquated equipment, with the conveyance of the passengers to a particular destination not being the principal purpose." The term refers to the particular physical operation, not to the nature of the railroad company as a whole that conducts the operation. As a result, part 238 would exempt not only a recreational train ride by a tourist railroad company that employed five people but also a recreational train ride by the Union Pacific Railroad Company, a Class I freight railroad. FRA has not yet had the opportunity to fully consult with tourist and historic railroad operators and their associations to determine the appropriate applicability of the provisions contained in the proposed rule to such railroad operations. The Federal Railroad Safety Authorization Act of 1994 directs FRA to examine the unique circumstances of tourist railroads when establishing safety regulations. The Act, which amended 49 U.S.C. 20103, states that:

In prescribing regulations that pertain to railroad safety that affect tourist, historic, scenic, or excursion railroad carriers, the Secretary of Transportation shall take into consideration any financial, operational, or other factors that may be unique to such railroad carriers. The Secretary shall submit a report to Congress not later than September 30, 1995, on actions taken under this subsection.

Pub. L. No. 103-440, § 217, 108 Stat. 4619, 4624, November 2, 1994. In its 1996 report to Congress entitled "Regulatory Actions Affecting Tourist Railroads," FRA responded to the direction in the statutory provision and also provided additional information related to tourist railroad safety for consideration of the Congress.

Section 215 of the 1994 Act specifically permits FRA to exempt equipment used by tourist, historic, scenic, and excursion railroads to transport passengers from the initial regulations that must be prescribed by November 2, 1997. 49 U.S.C.

20133(b)(1). FRA is addressing the passenger equipment safety concerns for these unique types of operations through the Tourist and Historic Railroads Working Group formed under RSAC. Any requirements proposed by FRA for these operations will be part of a separate rulemaking proceeding.

§ 238.5 Definitions. This section contains a set of definitions to introduce the regulations. FRA intends these definitions to clarify the meaning of important terms as they are used in the text of the proposed rule. Several of the definitions involve new or fundamental concepts which require further discussion.

"Brake indicator" means a device, actuated by brake cylinder pressure, which indicates whether brakes are applied or released on a car. The use of brake indicators in the performance of brake tests is a controversial subject. Rail labor organizations correctly maintain that brake indicators are not fully reliable indicators of brake application and release on each car in the train. Further, railroads correctly maintain that reliance on brake indicators is necessary because inspectors cannot always safely observe brake application and release. FRA believes that brake indicators serve an important role in the performance of brake tests. FRA has specified three different types of brake tests—Class I, Class IA, and Class II (described below)—that must be performed on passenger equipment. Railroads should perform Class I brake tests so that the inspector is able to actually observe brake application and release. However, FRA believes that during the performance of a Class IA brake test, railroads may rely on brake indicators if they determine that the inspector cannot safely make a direct observation of the brake application or release.

"Primary brake" and "secondary brake" are complementary definitions. "Primary brake" refers to "those components of the train brake system necessary to stop the train within the signal spacing distance without thermal damage to friction braking surfaces," while "secondary brake" refers to "those components of the train brake system which develop supplemental brake retarding force that is not needed to stop the train within signal spacing distances or to prevent thermal damage to wheels." FRA provides these definitions to help draw the line between safety and economics of brake systems. Railroads have long held that the dynamic portion of a blended brake is not a safety system. Under the provisions proposed in this rule, railroads must demonstrate through

testing and analysis that the dynamic brake fits the definition of a secondary brake. Defective primary braking systems are a serious safety problem that railroads must address immediately. Defective secondary braking systems, as defined in § 238.5, are not a serious safety concern, because, by definition, their failure does not result in unacceptable thermal inputs into friction brake components. Accordingly, FRA proposes to allow railroads more flexibility in dealing with defective secondary braking systems.

Three brake tests are fundamental to this proposed rule. A "Class I brake test" means a complete passenger train brake system test as further specified in § 238.313. The Class I test is the most complete test. It must be done once a day by qualified mechanical inspectors as opposed to train crews. The Class I test is intended to replace the current initial terminal brake test. See 49 CFR 232.12 (c)–(j). The proposed Class I test is much more tailored to the specific designs of passenger equipment than the initial terminal brake test that is required now.

A "Class IA brake test" means a test and inspection (as further specified in § 238.315) of the air brake system on each car in a passenger train to ensure the air brake system is 100 percent effective. The Class IA test is a somewhat less complete test than the Class I test. However, the Class IA test is equivalent to the current initial terminal brake test. An important difference between the Class I and Class IA tests is that the Class IA test may be performed by train crews as long as they have been qualified by the railroad to do so. The Class IA test allows commuter railroads the flexibility to have trains depart their first run of the day from an outlying point without having to station qualified mechanical inspectors at all outlying points. If railroads take advantage of the flexibility offered by the Class IA test, they must follow up with a Class I test sometime during the day.

A "Class II train brake test" means a test (as further specified in § 238.317) of brake pipe integrity and continuity from controlling locomotive to rear car. The proposed Class II brake test is a simple set-and-release test intended to replace the passenger train intermediate terminal air brake test. See 49 CFR 232.13(b). The Class II test is also tailored to the special design of the passenger equipment.

The concept of "ordered" or "date ordered" is vital to the correct application of this proposed rule. The terms mean the date on which notice to

proceed is given by a procuring railroad to a contractor or supplier for new equipment. Many of the provisions of the proposed rule, particularly structural requirements, will apply only to newly constructed equipment. When FRA proposes to apply requirements only to passenger equipment ordered on or after January 1, 1999, or placed in service for the first time on or after January 1, 2001, FRA intends to grandfather any piece of equipment that is both ordered before January 1, 1999, and placed in service for the first time before January 1, 2001. FRA believes this approach will allow railroads to avoid any costs associated with changes to existing orders and yet limit the delay in realizing the safety benefits of the requirements proposed in this rule.

FRA's proposed definition of "passenger car" goes beyond its traditional meaning. "Passenger car" means a unit of rolling equipment to provide transportation for members of the general public and includes a self-propelled car designed to carry passengers, baggage, mail, or express. This term includes a cab car, an MU locomotive, and a passenger coach. A cab car and an MU locomotive are also a "locomotive" under this rule. "Passenger coach" means a unit of rolling equipment intended to provide transportation for members of the general public that is without propelling motors and without a control stand; therefore, passenger coaches are a subset of passenger cars.

"Control stand" is defined in *The Railroad Dictionary of Car and Locomotive Terms* (Simmons-Boardman Publishing Corp. 1980), as "[t]he upright column upon which the throttle control, reverser handle, transition lever, and dynamic braking control are mounted within convenient reach of the engineer on a locomotive. The air gauges and some switches are also included on the control stand."

"Passenger equipment" is the most inclusive definition. It means all powered and unpowered passenger cars, locomotives used to haul a passenger car, and any other unit of rail rolling equipment hauled in a train with one or more passenger cars and includes a (1) Passenger coach, (2) cab car, (3) MU locomotive, (4) private car, (5) locomotive not intended to provide transportation for members of the general public that is used to power a passenger train, and (6) any non-self-propelled vehicle hauled in a train with one or more passenger cars, including a freight car hauled in a train with one or more passenger cars. The term therefore covers a baggage car, mail car, or express car.

The terms "passenger station" and "terminal" are crucial to the interpretation of the proposed rule for movement of defective equipment. "Passenger station" means a location designated in the railroad's timetable where passengers are regularly scheduled to get on or off any train. By contrast, "terminal" means a train's starting point or ending point of a single scheduled trip, where passengers may embark or disembark a train; normally, a "terminal" is a point where the train would reverse direction or change destinations.

Under certain carefully controlled conditions, FRA proposes to permit a passenger train with defective equipment to move to the next forward passenger station or terminal. This flexibility is allowed to prevent railroads from discharging passengers in potentially unsafe locations and to minimize schedule impacts where this can safely be done.

The concepts of "qualified person" and "qualified mechanical inspector" are vital to interpreting the proposed inspection, testing, and maintenance provisions of the rule. A "qualified person" is a person determined by the railroad to have the knowledge and skills necessary to perform one or more functions required under this part. With the proper training, a train crewmember could be a qualified person.

A "qualified mechanical inspector" is a "qualified person" who as a part of the training, qualification, and designation program required under § 238.111 has received instruction and training that includes "hands-on" experience (under appropriate supervision or apprenticeship) in one or more of the following functions: trouble-shooting, inspection, testing, and maintenance or repair of the specific train brake and other components and systems for which the inspector is assigned responsibility. Further, the mechanical inspector must be a person whose primary responsibility includes work generally consistent with those functions and is designated to (1) Conduct Class I brake tests under this part; (2) inspect MU locomotives or other passenger cars for compliance with this part; or (3) determine whether equipment not in compliance with this part may be moved safely and, if so, under what conditions. A train crewmember would not be a qualified mechanical inspector. (APTA believes that the proposed definition of "qualified mechanical inspector" adds nothing to safety, dictates work rules, and creates unnecessary restricted jobs with limited duties.)

FRA includes a clear definition of "qualified person" to allow railroads the flexibility of having train crews perform Class IA and Class II brake tests. A qualified person must be trained and designated as able to perform the types of brake inspections and tests that the railroad assigns to him or her. However, a qualified person need not have the extensive knowledge of brake systems or components or be able to trouble-shoot and repair them. The qualified person is the "checker." He or she must have the knowledge and experience necessary to be able to identify brake system problems.

FRA provides a clear definition of qualified mechanical inspector so that a differentiation can be made between the thorough brake test and inspection performed by a professional mechanical employee, and the less comprehensive brake checks performed by train crews. Under FRA's proposal, only qualified mechanical inspectors are permitted to perform the required calendar day inspections and Class I brake tests under this part. This definition largely rules out the possibility of train crewmembers becoming a qualified mechanical inspector. Part of the definition requires the primary job of a qualified mechanical inspector to be inspection, testing, or maintenance of passenger equipment. FRA intends the definition to allow the members of the trades associated with testing and maintenance of equipment such as carmen, machinists, and electricians to become qualified mechanical inspectors. However, membership in labor organizations or completion of apprenticeship programs associated with these crafts is not required to be a qualified mechanical inspector. The two primary qualifications are possession of the knowledge required to do the job and a primary work assignment inspecting, testing, or maintaining the equipment.

Discussions conducted in the Working Group meetings revealed that railroad operators believe these definitions are too restrictive and will require training beyond the minimum needed for many employees to do their jobs. On the other hand, the representatives of labor organizations maintain that this approach will allow unqualified train crewmembers to conduct tests and inspections that should be performed only by mechanical employees.

FRA believes the proposed rule strikes the correct balance between these conflicting points of view. FRA agrees with labor representatives that mechanical employees generally conduct a more thorough inspection

than train crewmembers. As a result, the rule calls for a daily Class I brake test and mechanical inspection performed by qualified mechanical inspectors. At the same time, FRA agrees with railroad operators that properly trained train crews are capable of performing brake tests and have been doing so effectively for years. As a result, the proposed rule grants flexibility to railroads to use properly trained train crewmembers to perform certain brake tests.

"System safety" is another concept that forms a foundation for the proposed rule. System safety means the application of design, operating, technical, and management techniques and principles throughout the life cycle of a system to reduce hazards and unsafe conditions to the lowest level possible through the most effective use of the available resources. FRA proposes that each railroad implement a system safety program to identify and manage safety risks. The system safety program would generate data to be used to make safety decisions. The risk identification and analysis portion of the system safety program would help demonstrate an alternate means of achieving equivalent safety when a proposed operation does not fully comply with the Passenger Equipment Safety Standards.

Definitions of the various types of trains covered by the proposed standards are extremely important to understand how FRA proposes that the rule be applied. The most general definition is that of a "passenger train." The proposed definition makes two points very clear. First, the proposed rule does not apply to tourist and excursion railroads; and, second, the provisions of the rule do apply to non-passenger carrying units included in a passenger train.

An important distinction highlighted in these definitions is the difference between a "long-distance intercity passenger train" and a "short-distance intercity passenger train." "Long-distance intercity passenger train" means a passenger train that provides service between large cities more than 125 miles apart and is not operated exclusively in the National Railroad Passenger Corporation's (Amtrak) Northeast Corridor. "Short-distance intercity passenger train" means a passenger train that provides service exclusively on the Northeast Corridor or between cities that are not more than 125 miles apart. This distinction attempts to recognize the special set of operating conditions on the Northeast Corridor in light of the need to treat long-distance trains differently than short-distance trains. Additionally, APTA has advised FRA that there are

commuter rail systems that operate trains over 100 miles in distance on a single run, and thus recommended the use of the 125-mile distance in these definitions.

The definition of the term "in service" is modeled after the definition of that term in the Railroad Freight Car Safety Standards. See 49 CFR 215.5(e). Passenger equipment that is in service includes passenger equipment "in passenger service," meaning "carrying, or available to carry, fare-paying passengers," as well as all other passenger equipment unless it falls into one of four categories; specifically, unless the passenger equipment—

- (a) Is being handled in accordance with §§ 238.15, 238.17, 238.305(c)(5), or 238.503(f), as applicable;
- (b) Is in a repair shop or on a repair track;
- (c) Is on a storage track and is not carrying passengers; or
- (d) Has been delivered in interchange but has not been accepted by the receiving railroad.

The term "in service" is important because if the train or passenger equipment is not in service, it is not subject to a part 238 civil penalty.

The last definition that warrants discussion is "vestibule." FRA proposes "vestibule" to mean an area of a passenger car that normally does not contain seating and that leads from the seating area to the side exit doors. The definition of "vestibule" is important to determine the requirements for the location of side door emergency-release mechanisms.

§ 238.7 Waivers. This section sets forth the procedures for seeking waivers of compliance with the requirements of this rule. Requests for such waivers may be filed by any interested party. In reviewing such requests, FRA conducts investigations to determine if a deviation from the general criteria can be made without compromising or diminishing rail safety.

FRA recognizes that circumstances may arise when the operation of passenger equipment that does not meet the standards proposed in this rule is appropriate and in the public interest. FRA would entertain petitions for waiver to allow operation of equipment that does not fully comply with the proposed standards, provided the petitioner can demonstrate that the equipment will operate at a level of safety equivalent to that afforded by the provision of this part that is sought to be waived, *i.e.*, demonstrate "equivalent safety." Equivalent safety may be afforded by features that compensate for equipment that does not meet these standards. Equivalent safety is met when railroad employees, passengers,

and the general public are no more at risk from passenger equipment that does not meet the requirements of this part, but is protected by compensating features, than when the equipment meets the requirements of this part.

Some of the structural requirements that FRA is proposing would prohibit the operation of most light rail vehicles if the operation is connected to the general railroad system on or after January 1, 1998; however, FRA does not intend to completely foreclose the possibility of the operation of such equipment. FRA is aware of arrangements by which light rail service is conducted during the day, with freight operations conducted at night. FRA will entertain petitions for waiver of the structural requirements from operators of such "time-separated" service.

FRA proposes that the risk assessment portion of the system safety program be used to demonstrate equivalent safety. The burden would be on the petitioning railroad to perform a comparative risk assessment and to prove equivalent safety. FRA has experience with two instances involving different passenger equipment operations where a comparative risk assessment has been used successfully. Amtrak commissioned a comparative risk assessment between current Northeast Corridor operations and proposed operations involving the American Flyer trainset at speeds up to 150 mph. The risk assessment demonstrated that proposed countermeasures such as enhancements to the train control system and the increased structural strength and the crash energy management design of the American Flyer should compensate for the increased operating speed. The comparative risk assessment quantitatively showed that passengers were no more at risk travelling on the American Flyer at 150 mph on the Northeast Corridor than if they were travelling on an existing Amtrak passenger train at a lesser speed on the same corridor.

The second instance is the proposed Florida Overland Express (FOX) operation of a French TGV high speed rail system in Florida. FOX performed a comparative risk assessment of three operations: the American Flyer on the Northeast Corridor, the TGV on high speed lines in France, and the proposed FOX operation in Florida. See FRA Docket: RM Pet. 97-1. The analysis showed the TGV operation in France to pose less risk to passengers than the American Flyer trainset on the Northeast Corridor and the proposed FOX operation to be even safer than the

TGV in France. The FOX risk assessment suggested that collision avoidance provided by a dedicated right-of-way with no grade crossings more than compensated for the increased speed and decreased structural strength of the proposed equipment.

FRA cites these two instances as examples of what is expected to demonstrate equivalent safety for proposed operations where the equipment does not meet the Passenger Equipment Safety Standards. FRA would expect an analysis showing the effectiveness of clearly compensating features, such as closing grade crossings, providing absolute separation of lighter rail equipment from heavy rail equipment, or using highly capable signal and train control systems that significantly reduce the probability of accidents caused by human error. FRA would provide advice and guidance to organizations wishing to demonstrate equivalent safety, but the burden of performing a comparative risk assessment and establishing that the operation provides equivalent safety is on the entity proposing to operate equipment that does not comply with this part.

§ 238.9 Responsibility for compliance. General compliance requirements are proposed in this section. Paragraph (a). Paragraphs (a)(1) and (a)(2) prohibit a railroad subject to part 238 from committing a series of specified acts with respect to a train or a piece of passenger equipment while the train or passenger equipment is in service if it has a condition that does not comply with part 238 or if it has not been inspected and tested as required by part 238. In particular, consistent with 49 U.S.C. chapter 203, under which the provision is proposed, paragraph (a)(1) imposes a strict liability standard with respect to violations of the safety appliance and power brake provisions of part 238. In addition to the acts prohibited by paragraph (a)(2) (that is, the use, haul, offering in interchange, or accepting in interchange of defective or not properly inspected equipment), paragraph (a)(1) prohibits a railroad from merely permitting the use or haul on its line of such equipment if it does not conform with the safety appliance and power brake provisions. See § 238.3(b). By contrast, paragraph (a)(2) imposes a lower standard of liability for using, hauling, delivering in interchange, or accepting in interchange a train or passenger equipment that is defective or not properly inspected, in violation of another provision of this part; a railroad subject to this part is liable only if it knew, had notice, or

should have known of the existence of either the defective condition of the equipment or the failure to inspect and test. Finally, paragraph (a)(3) establishes a strict liability standard for noncompliance with any other provision of this part, for example, the requirement to adopt a written system safety plan under § 238.103.

Paragraph (b). In accordance with the "use" or "haul" language previously contained in the Safety Appliance Acts (49 U.S.C. chapter 203) and with FRA's general rulemaking authority under the Federal railroad safety laws, FRA proposes in paragraph (b) that passenger equipment will be considered "in use" prior to departure but after it receives or should have received the necessary tests and inspections required for movement. FRA will no longer wait for a piece of equipment with a power brake defect to be hauled before issuing a violation, a practice frequently criticized by the railroads. FRA believes that this approach will increase FRA's ability to prevent the movement of defective equipment that creates a potential safety hazard to both the public and railroad employees. FRA does not feel that this approach increases the railroads' burden since equipment should not be operated if it is found in defective condition in the pre-departure tests and inspections, unless permitted by the regulations.

Paragraph (c). This paragraph clarifies FRA's position that the requirements contained in the proposed rules are applicable not only to any "railroad" subject to this part but also to any "person," as illustrated in § 238.11, that performs any function required by the proposed rules. Although various sections of the proposed rule address the duties of a railroad, FRA intends that any person who performs any action on behalf of a railroad or any person who performs any action covered by the proposed rule is required to perform that action in the same manner as required of a railroad or be subject to FRA enforcement action. For example, private car owner and contract shippers that perform duties covered by these proposed regulations would be required to perform those duties in the same manner as required of a railroad.

§ 238.11 Civil penalties. Section 238.11 identifies the civil penalties that FRA may impose upon any person, including a railroad or an independent contractor providing goods or services to a railroad, that violates any requirement of this part. These penalties are authorized by 49 U.S.C. 21301, 21302, and 21304. The penalty provision parallels penalty provisions included in numerous other safety regulations issued by FRA. Essentially,

any person who violates any requirement of this part or causes the violation of any such requirement will be subject to a civil penalty of at least \$500 and not more than \$10,000 per violation. Civil penalties may be assessed against individuals only for willful violations; where a grossly negligent violation or a pattern of repeated violations creates an imminent hazard of death or injury to persons, or causes death or injury, a penalty not to exceed \$20,000 per violation may be assessed. In addition, each day a violation continues will constitute a separate offense. Finally, a person may be subject to criminal penalties under 49 U.S.C. 21311 for knowingly and willfully falsifying reports required by these regulations. FRA believes that the inclusion of penalty provisions for failure to comply with the regulations is important in ensuring that compliance is achieved.

The final rule will include a schedule of civil penalties as appendix A to this part. Because such penalty schedules are statements of policy, notice and comment are not required prior to their issuance. See 5 U.S.C. 553(b)(3)(A). Nevertheless, commenters are invited to submit suggestions to FRA describing the types of actions or omissions under each regulatory section that would subject a person to the assessment of a civil penalty. Commenters are also invited to recommend what penalties may be appropriate, based upon the relative seriousness of each type of violation.

§ 238.13 Preemptive effect. Proposed § 238.13 informs the public as to FRA's views regarding what will be the preemptive effect of the final rule. While the presence or absence of such a section does not in itself affect the preemptive effect of a final rule, it informs the public concerning the statutory provision which governs the preemptive effect of the rule. Section 20106 of title 49 of the United States Code provides that all regulations prescribed by the Secretary relating to railroad safety preempt any State law, regulation, or order covering the same subject matter, except a provision necessary to eliminate or reduce an essentially local safety hazard that is not incompatible with a Federal law, regulation, or order and that does not unreasonably burden interstate commerce. With the exception of a provision directed at an essentially local safety hazard, 49 U.S.C. 20106 will preempt any State regulatory agency rule covering the same subject matter as the regulations proposed today when issued as final rules.

§ 238.15 Movement of passenger equipment with defective power brakes. This section contains the proposed requirements for movement of passenger equipment with a power brake defect without civil penalty liability under this part. (Railroads remain liable, however, "in a proceeding to recover damages for death or injury of a railroad employee arising from the movement of" the defective equipment. See 49 U.S.C. 20303(c).) A "power brake defect," as defined in paragraph (a), "is a condition of a power brake component, or other primary brake component, that does not conform with this" rule. The term does not include a failure to properly inspect such a component.

The Passenger Equipment Safety Standards Working Group did not reach a consensus on the requirements proposed in this section; however, the Working Group did agree that passenger operations needed some flexibility to get passengers to their destination or, at a minimum, to a location where passengers can safely disembark. The proposed requirements regarding the movement of passenger equipment with defective power brakes are based on the extensive discussions and information presented in the Working Group meetings and in response to the previous NPRM on power brakes.

As previously noted in the general discussion, FRA proposes to utilize the authority granted in 49 U.S.C. 20306 to exempt passenger train operations covered by this part from the statutory requirements contained in 49 U.S.C. 20303(a) permitting the movement of equipment with defective or insecure brakes only if various requirements are met, including the requirement that the movement for repair be only to the nearest location where the necessary repairs can be made. FRA believes that the granting of this exemption is justified based on the technological advances made in the brake systems and equipment used in passenger operations, and is necessary for these operations to make efficient use of the technological advances and protect the safety of the riding public.

FRA also proposes to exempt passenger train operations from a long-standing agency interpretation, based on a 1910 Interstate Commerce Commission order codified at 49 CFR 232.1, that prohibits the movement of a train for repairs under 49 U.S.C. 20303 if less than 85 percent of the train's brakes are operative. As noted in the previous discussion, many passenger operations utilize a small number of cars in their trains and the necessity to cut out the brakes on just one car can easily result in noncompliance. FRA

believes that speed restrictions can readily be used to compensate for the loss of brakes on a minority of cars.

Paragraph (b)(1). This paragraph addresses the movement for repair of equipment with a power brake defect found during a Class I or IA brake test or, for Tier II equipment, the equivalent of a Class I or IA brake test. This paragraph allows railroads the flexibility to move passenger equipment with a power brake defect found during such a test if the following three conditions are satisfied: (1) if the train is moved for purposes of effecting repair of the defect, without passengers; (2) the applicable operating restrictions set forth in paragraph (d) are complied with; and (3) the information concerning the defect is recorded on a tag affixed to the equipment or in an automated defect tracking system as specified in paragraph (c)(2).

Paragraph (b)(2). This paragraph permits railroads to move, for purposes of scrapping or sale, passenger equipment with a power brake defect found during a Class I or IA brake test (or the Tier II equivalent) if each of the following conditions is satisfied: if the movement is without passengers, if the speed of the movement is 15 mph or less, and if the railroad's air brake or power brake instructions are followed when making the movement. This provision allows railroads to move surplus equipment without having to request permission for one-time moves from FRA, as is currently required. FRA has not had any serious safety concerns with the methods currently used by railroads to move this equipment and does not believe its limited resources should be tied up in approving these types of moves.

Paragraph (c), generally. This paragraph addresses the use of passenger equipment with a power brake defect that develops en route from a location where a Class I or IA brake test (or the Tier II equivalent) was performed on the equipment. The two basic requirements are that at the location where the railroad first finds the defect, specified information (such as the nature of the defect and the destination where the defect will be repaired) must be placed on tags attached to the equipment or in a computer tracking system and that the railroad must observe the applicable operating restrictions in paragraph (d). A third requirement, found in paragraph (c)(3) is a special, applying only if the defect causes any brakes to be cut out.

Paragraph (c)(2) requires that equipment being hauled for repairs be adequately identified. Currently, there is no requirement that equipment with

defective power brakes be tagged or otherwise identified, although most railroads voluntarily engage in such activity. Furthermore, the current regulations regarding freight cars and locomotives contain tagging requirements for the movement of equipment not in compliance with those parts. See 49 CFR 215.9 and 229.9. Consequently, FRA proposes to require the identification of equipment with defective power brakes through either the traditional tags which are placed in established locations on the equipment or by an automated tracking system developed by the railroad. FRA proposes certain information which must be contained whichever method is used by a railroad. FRA believes that the proposed tagging or tracking requirements add reliability, accountability, and enforceability for the timely and proper repair of equipment with defective power brakes.

In addition, under paragraph (c)(3), if the defect causes the brakes on the equipment to be cut out, then the railroad must first find out what percentage of the power brakes in the train are cut out or inoperative in some other way, using the formula in paragraph (d)(1). Next, the railroad must notify the dispatcher of the percentage of operative brakes and the movement restrictions imposed by paragraph (d), inform the railroad's mechanical desk or department about the brake defect, and walk the train to confirm the percentage of operative brakes at the next point where it is safe to do so.

Paragraph (d)(1). This paragraph explains the term "inoperative power brakes" and proposes a new method for calculating the percentage of operative power brakes (operative primary brakes) in a train. Regarding the term itself, a cut-out power brake is an inoperative power brake, but the failure or cutting out of a secondary brake system (as defined in § 238.5) does not result in inoperative power brakes. For example, failure of dynamic brakes does not render a power brake inoperative unless the dynamic brakes are in fact primary brakes. Although the statute discusses the percentage of operative brakes in terms of a percentage of vehicles, the statute was written nearly a century ago and at that time the only way to cut out the brakes on a car or locomotive was to cut out the entire unit. See 49 U.S.C. 20302(a)(5)(B). Today, virtually every piece of equipment used in passenger service can have the brakes cut out on a per-truck or per-axle basis. Consequently, FRA merely proposes a method of calculating the percentage of operative brakes based on the design of passenger equipment used today, and

thus, a means to more accurately reflect the true braking ability of the train as a whole. FRA believes that the proposed method of calculation is consistent with the intent of Congress when it drafted the statutory requirement and simply recognizes the technological advancements made in braking systems over the last century. Consequently, FRA proposes to permit the percentage of operative brakes to be determined by dividing the number of axles in the train with operative brakes by the total number of axles in the train. Furthermore, for equipment utilizing tread brake units (TBU), FRA proposes that the percentage of operative brakes be determined by dividing the number of operative TBUs by the total number of TBUs.

Paragraphs (d)(2)-(d)(4), generally. These paragraphs propose various speed and other operating restrictions based on the percentage of operative brakes in order to permit passenger railroads the flexibility to efficiently move passengers without compromising safety. FRA believes that the proposed movement restrictions actually enhance the safety of the riding public. The proposed requirements retain the basic principle that a train carrying passengers shall not depart a location where a major brake inspections or tests are performed on that train unless the train has 100 percent operational brakes.

FRA recognizes that there are major differences in the operations of commuter or short-distance intercity passenger trains, and long-distance intercity passenger trains. Commuter and short-distance intercity passenger trains tend to operate fairly short distances between passenger stations and generally operate in relatively short turn-around service between two terminals several times in any given day. On the other hand, long-distance intercity passenger trains tend to operate for long distances, with trips between the beginning terminal and ending terminal taking a day or more and traversing multiple States with relatively long distances between passenger stations. Consequently, FRA proposes slightly different requirements with regard to the movement of defective brake equipment in long-distance intercity passenger trains.

FRA believes that passenger railroads can safely and efficiently operate trains with en route brake failures under the strict set of conditions proposed. FRA has long held that the industry can safely operate trains at normal track speeds with as low as 85 percent effective brakes as long as the inoperative brakes were due to failures which occurred en route or due to

defective cars being picked up en route and being moved for repairs. The only change being proposed to current practice is the additional flexibility for certain passenger operations to move the equipment past a location capable of performing the repairs.

Paragraph (d)(2). This paragraph proposes operating requirements for the movement of any passenger train that develops en route brake failures resulting in 74 to 50 percent operative brakes. In these circumstances, FRA proposes to allow the trains to proceed only to the next passenger station at a reduced speed, not to exceed 20 mph, to discharge passengers before proceeding, without passengers, to the nearest location where the necessary repairs can be made. This provision recognizes the dangers of unloading passenger at locations other than passenger stations by allowing railroads to move the equipment to a location with the facilities to handle the discharge of passengers. Furthermore, engineering evidence and test data demonstrate that the reduced speed more than compensates for the reduced braking force. At the reduced speed, even with only 50 percent effective brakes, a train is able to stop in a much shorter distance than the same train traveling at the maximum operating speed with 100 percent operative brakes.

Paragraph (d)(3)(i). FRA also proposes to permit commuter, short-distance intercity, and short-distance Tier II passenger trains experiencing en route brake failures resulting in 84 to 75 percent operative brakes to continue in service to the next terminal prior to being moved without passengers to the nearest location where repairs can be made. However, in these circumstances, FRA proposes that the speed of the train must be reduced to 50 percent of the train's maximum operating speed or 40 mph, whichever is less. Engineering evidence and test data demonstrate that the reduced speed more than compensates for the reduced braking force. At the reduced speed, even with only 75 percent effective brakes, a train is able to stop in a much shorter distance than the same train traveling at the maximum operating speed with 100 percent operative brakes.

Paragraph (d)(3)(ii). FRA proposes to permit commuter and short-distance intercity passenger trains that develop defective brake equipment en route resulting in 99 to 85 percent operative brakes, the flexibility to move the defective equipment to the next terminal where passengers can be unloaded, prior to the defective equipment being moved to the nearest

location where repairs can be made. During Working Group meetings, APTA presented engineering evidence and test data that demonstrated that stopping distances remained well within signal spacing distances with a large margin of safety even for trains with as low as 85 percent effective brakes.

Paragraph (d)(4). As noted above, most long-distance intercity passenger trains, both in Tier I and Tier II, have considerable distances between their starting terminal and their ending terminal, thus FRA does not intend to provide these operations the latitude to move those large distance with defective equipment entrained. This paragraph permits the movement of defective brake equipment in these trains only to the nearest forward location designated as a repair location for this equipment by the operating railroad in the list required by § 238.19(d). FRA also proposes to permit long-distance intercity passenger trains to continue in service past a designated repair location to the next forward passenger station only if the designated repair location does not have the facilities to safely unload passengers. Although FRA proposes to permit the continued operation of long-distance intercity passenger trains that develop en route brake failures resulting in 99 to 85 percent operative brakes at normal speeds, FRA proposes a speed restriction of no greater than 40 mph when the en route brake failures result in 84 to 75 percent operative brakes. Therefore, although long-distance intercity passenger trains do not have the flexibility to continue in service to the next terminal, these trains do gain flexibility in being permitted to move a greater percentage of defective equipment than currently allowed and are able to move that equipment to the next forward repair location rather than the "nearest" repair location as currently required. 49 U.S.C. 20303(a). As noted previously, FRA believes that the safety of the traveling public mandates the flexibility of permitting passenger trains to continue to the next forward repair location or passenger station because requiring trains to reverse directions and perform back hauls to the nearest repair location increases the risk of collision on the railroad.

APTA, in its comments on a draft of the NPRM, agreed that many of the defects need to be repaired but do not require stopping the car or immediately taking it out of service. Commenters are requested to address APTA's concern.

§ 238.17 Movement of passenger equipment with other than power brake defects. This section contains the

proposed requirements for the movement of passenger equipment with a condition not in compliance with part 238, excluding a power brake defect and including a safety appliance defect, without civil penalty liability under this part. (Railroads remain liable, however, under 49 U.S.C. 20303(c), as described in the discussion of the previous section.)

The Working Group was unable to reach full consensus on the requirements contained in this section. There are currently no statutory or regulatory restrictions on the movement of passenger cars with defective conditions that are not power brake or safety appliance defects. The proposed provisions contained in this section are similar to the provisions for moving defective locomotives and freight cars currently contained in 49 CFR 229.9 and 215.9, respectively. As these provisions have generally worked well with regard to the movement of defective locomotives and freight cars and in order to maintain consistency, FRA has modeled the proposed movement requirements on those existing requirements. FRA proposes to allow passenger railroads the flexibility to continue to use equipment with non-safety-critical defects until the next scheduled calendar day exterior mechanical inspection. However, FRA intends the calendar day mechanical inspection to be the tool used by railroads to repair all reported defects and to prevent continued use of defective equipment to carry passengers. (Compare § 238.17(b) with § 238.17(c).)

FRA intends for 49 CFR 229.9 to continue to govern the movement of locomotives used in passenger service which develop defective conditions, not covered by part 238, that are not in compliance with part 229. In the final rule, FRA will make any necessary conforming amendments to part 229 in order to remove provisions that will now be covered in this part or to make inapplicable to locomotives subject to part 238 provisions of part 229 that will now be covered in part 238. Part 229 will continue to cover (non-steam) locomotives that are used by the tourist railroads until such railroads are covered by part 238.

FRA also does not intend to alter the current statutory requirements contained in 49 U.S.C. 20303 regarding the movement of passenger equipment with defective or insecure safety appliances. See proposed §§ 238.229, 238.429, 238.431. Consequently, in paragraph (d), FRA proposes to require that passenger equipment that develops a defective or insecure safety appliance continue to be subject to all the

statutory restrictions on its movement. Under the current statutory language—

A vehicle that is equipped in compliance with this chapter whose equipment becomes defective or insecure nevertheless may be moved when necessary to make repairs * * * from the place at which the defect or insecurity was first discovered to the nearest available place at which the repairs can be made-

(1) on the railroad line on which the defect or insecurity was discovered; or

(2) at the option of a connecting railroad carrier, on the railroad line of the connecting carrier, if not farther than the place of repair described in clause (1) of this subsection.

49 U.S.C. 20303(a). It should be noted that the proposed requirement applicable to Tier I equipment merely references the Railroad Safety Appliance Standards (49 CFR part 231); however, FRA has proposed separate safety appliance requirements for Tier II passenger equipment. See proposed §§ 238.429 and 238.431.

FRA proposes that passenger equipment that is found with conditions not in compliance with this part, other than power brake defects, be moved only after a qualified mechanical inspector has determined that the equipment is safe to move and determined any restrictions necessary for the equipment's safe movement. FRA also proposes to allow railroads to move equipment based on an assessment made by a qualified mechanical inspector in communication with on-site personnel. FRA proposes this allowance based on the reality that mechanical personnel are not readily available at every location on a railroad's line of road. However, FRA further proposes that if a qualified mechanical inspector does not actually inspect the equipment to determine that it is safe to move, then, at the first forward location where a qualified mechanical inspector is on duty, an inspector will perform a physical inspection of the equipment to confirm the initial assessment made while in communication with on-site personnel previously. Paragraph (c)(3) requires tracking of the defect in either of two ways. One option is to tag the equipment in a manner similar to what is currently required under § 215.9 for freight cars. The second option is to record the specified information in an automated tracking system. The latter alternative is offered to provide railroads some flexibility and in recognition of advances made in electronic recordkeeping.

Under paragraph (c), FRA proposes that after a mechanical inspector verifies that a noncomplying piece of equipment is safe to remain in passenger service,

that piece of equipment may remain in passenger service until its next calendar day mechanical inspection. However, under paragraph (b), equipment containing noncomplying conditions at the time of the calendar day mechanical inspection may be moved from that location only if the noncomplying conditions are repaired or if all of the following conditions are satisfied: (1) if the equipment is moved out of passenger service and in a non-revenue train for the purpose of effectuating the repairs; (2) if the requirements of paragraphs (c)(2) and (c)(3) (regarding tagging and notification) are satisfied; and (3), in the case of a safety appliance defect, if the special conditions of paragraph (d) are met. As discussed previously, FRA has intentionally provided railroads wide flexibility in where and when it will perform the calendar day mechanical inspection in order to permit railroads to get the equipment to locations most conducive to conducting the inspections. Thus, FRA intends for calendar day mechanical inspections of passenger equipment to be conducted at locations where qualified mechanical inspectors are available and where virtually any necessary repair can be made. Consequently, FRA does not believe that the proposed restrictions on the movement of noncomplying equipment will be overly burdensome to the industry.

Paragraph (d) states the special statutory restrictions on the movement of passenger equipment with a safety appliance defect.

APTA, in its comments on a draft of the NPRM, agreed that many of the defects need to be repaired but do not require shopping the car or immediately taking it out of service. APTA further noted that this section does not take into account the fact-based maintenance cycles for equipment, subsystems, and components as the introduction of technology outpaces the regulatory process. Commenters are requested to address APTA's concerns.

§ 238.19 Reporting and tracking defective equipment. This section contains the reporting and tracking requirements that passenger railroads must maintain regarding defective passenger equipment. The Working Group did not reach consensus on the requirements proposed in this section. FRA proposes to require that each railroad develop and maintain a system for reporting and tracking equipment defects. FRA proposes that for each equipment defect discovered by the railroad on equipment used by the railroad the system record: the number by which the equipment is identified,

type of defect, when the defect occurred, the determination made by a qualified mechanical inspector on how to handle the defect, and finally how and when the defect was corrected. FRA has not proposed any specific method or means by which a railroad should gather and maintain the required information. FRA believes that each railroad is in the best position to determine the method of obtaining the required information which is most efficient and effective based on its specific operation. Thus, railroads could maintain this information electronically in conjunction with their automated tracking system, if so desired.

FRA believes that reporting and tracking of defective equipment are essential features of any effective system safety program. Railroad managers are able to utilize such systems to ensure that the railroad complies with safety regulations, does not use unsafe equipment, makes needed repairs, and has failure data to make reliability-based decisions on maintenance intervals. Furthermore, most passenger railroads currently have some sort of reporting and tracking system in place. FRA recognizes that some railroads may have to incur additional initial costs to develop or improve defect reporting and tracking systems; however, FRA believes these costs can be recouped through the increased operating efficiency that an effective recording and tracking system provides.

Paragraph (b) requires that railroads maintain the required information for a period equal to one periodic maintenance interval for each specific type of equipment as described in the railroad's system safety plan. FRA believes that this minimum retention period will ensure that the records remain available when they are most needed, but will not place a burdensome record storage requirement on railroads. However, FRA strongly encourages railroads to keep these records for longer periods of time because they form the basis for future reliability-driven decisions concerning test and maintenance intervals.

Paragraph (d) requires railroads operating long-distance passenger trains to list the locations where repairs can be made to the equipment. FRA believes that the operators are in the best position to determine which locations have the necessary expertise to handle the repairs of the somewhat advanced braking systems utilized in passenger trains. FRA also proposes a broad performance-based requirement that railroads operating this equipment designate a sufficient number of repair locations to ensure the safe and timely

repair of the equipment. FRA intends to fine a railroad for violating this proposed requirement or take other enforcement action if, based on its expertise and experience, FRA believes the railroad is failing to designate an adequate number repair locations.

§ 238.21 Special approval procedure. This section states the procedures to be followed when seeking to obtain FRA approval of a pre-revenue service acceptance testing plan under §§ 238.113 or 238.603 or an alternative standard under §§ 238.115 ("Fire safety"), 238.223 ("Fuel tanks"), 238.309 ("Periodic brake equipment maintenance"), 238.311 ("Single car test"), 238.405 ("Longitudinal static compressive strength"), or 238.427 ("Suspension system"). Procedures for obtaining FRA approval of inspection, testing, and maintenance programs for Tier II equipment under § 238.503 are found at § 238.505.

Subpart B—System Safety and General Requirements

§ 238.101 Scope. This subpart contains the system safety program requirements to be applied to all passenger equipment subject to this part. Although FRA initially considered addressing system safety requirements for Tier I and Tier II equipment separately, FRA is proposing broad, minimum requirements which can be applied to all types of passenger railroad systems. Therefore, separate requirements are not needed.

The Working Group did not reach consensus on the system safety requirements as they apply to Tier I equipment, but strong support exists among Working Group members to apply formal system safety planning to Tier I equipment. The Tier II Subgroup did reach full consensus on the system safety program requirements as they apply to Tier II equipment.

Tier I and Tier II passenger equipment is used in a heavy rail environment that includes a mixture of freight and rail passenger traffic and highway-rail grade crossings used by heavy highway vehicles. Such an environment makes reliance on collision avoidance risky. As a result, crashworthiness must be designed into the equipment.

However, situations may arise where requiring strict adherence to either the Tier I standards or the Tier II standards may prevent rail passenger transportation that is in the public interest. As a result, FRA intends that the system safety planning process allow railroads to develop approaches to providing rail passenger transportation that do not meet all the Passenger Equipment Safety Standards but

compensate by providing safety equivalency to that provided by meeting the full set of equipment safety standards. For example, a rail passenger operator would be allowed to seek relief from some of the structural standards based on a dedicated right-of-way or an advanced signaling system. However, the burden of demonstrating safety equivalency based on a comprehensive risk assessment falls squarely on the organization proposing the rail passenger operation that does not meet all the equipment standards.

The system safety plan must be a living document that evolves with the passenger rail system, and the system safety program detailed in the plan should be enforced until the system is decommissioned. Ideally, the system safety program would be in place at the inception of the system. This allows the maximum benefit of the program to be achieved. Tier II equipment and major new purchases of Tier I equipment will allow system safety planning to be used in the design and development phase of the new equipment. However, for the most part, Tier I system safety programs must be tailored to existing operations and equipment.

The system safety approach can be instituted at any point in the life cycle of a passenger rail system. APTA currently publishes a voluntary system safety program guide. Several APTA members, which operate existing Tier I equipment, instituted this system safety program on their existing rail systems. APTA periodically audits these programs and provides the operating authority with feedback on how well the system safety program has been implemented. As previously noted, APTA has suggested that commuter railroads be allowed to regulate themselves in this area, and that FRA not issue any regulations governing such plans. See preamble discussion; in the preamble FRA asked a variety of questions that commenters should address regarding the need for system safety plans, and if such plans should be required what their contents should contain and whether FRA should enforce the various elements of the plans.

In addition, Amtrak recently started a corporate system safety program initiative to make a formal system safety program an integral part of the way Amtrak conducts business. The value of the formal system safety process is rapidly being recognized by the passenger railroad industry and is becoming an accepted way of doing business.

§ 238.103 General system safety requirements. Paragraph (a) requires

each railroad operating equipment subject to this part to adopt and annually update a system safety plan and implement a system safety program using MIL-STD-882(C) as a guide. MIL-STD-882(C) is a military standard issued by the Department of Defense that describes system safety planning and system safety programs used by the United States military for procuring and operating weapon systems. See also the discussion under § 238.5 of this section-by-section analysis. FRA does not attempt to dictate to railroads how to apply this guidance. Railroads should tailor their application of the guidance to their unique safety needs and operating scenarios.

Paragraphs (b)–(d) describe the various elements required to be included in the plan. In particular, paragraph (e) requires the operating railroad to document how the design meets safety requirements and to track how safety issues were raised and resolved. This is a necessary step to demonstrate that risks were identified and eliminated or mitigated.

Paragraph (f) requires the system safety plan to describe how operational limitations are to be imposed if the design cannot meet certain safety requirements. Operational limits are the least desirable and thus the last means considered to reduce a safety risk.

Paragraph (g) establishes the dates by which the operating railroad must adopt a system safety plan for each of the three categories of passenger equipment.

Paragraph (h) obliges the railroad to allow FRA to inspect and copy its system safety plan and the documentation required by paragraph (e).

§ 238.105 Fire protection program. Paragraph (a) requires that the operating railroad's system safety program address the fire safety of new equipment during the design stage so as to reduce the risk of harm due to fire on such equipment to an acceptable level as defined in MIL-STD-882(C). Paragraph (b) requires that railroads make a written analysis of the fire protection problem. These paragraphs require the operating railroad to ensure that good fire protection practice is used during the design and operation of the equipment. Using this good practice will allow the FRA fire safety regulations to be kept to a minimum. Four elements of this analysis correspond to required action under § 238.115, "Fire safety": the installation of overheat detectors, a fire or smoke detection system, and a fixed, automatic, fire-suppression system where the railroad's written analysis determines they are required and compliance with the railroad's written

procedures for the inspection, testing, and maintenance of fire safety systems and equipment that such procedures designate as mandatory. See § 238.115(c)-(f).

Paragraph (c) requires the operating railroad to exercise reasonable care to assure that the system developer follows the design criteria and performs the tests required by the railroad's fire safety program during the design of new equipment. To fulfill this obligation in part, the operating railroad must include fire safety requirements in each of its contracts for the purchase of new equipment.

Paragraph (d) requires that existing passenger equipment and operations be subjected to a fire safety analysis similar to that proposed for new equipment in paragraphs (a)-(c). A preliminary fire safety analysis would be required within the first year. This effort would constitute an overview of the fleet and service environments, together with known elements of risk (e.g., tunnels). For any category of equipment and service identified as possibly presenting unacceptable risk, a full analysis and any necessary remedial action would be required within the following year. A full fire safety analysis, including review of the extent to which interior materials in all existing cars comply with the test performance criteria for flammability and smoke emission characteristics contained in Appendix B to this part or alternative standards approved by FRA under this part, would be required within 4 years. This overall review would closely parallel and reinforce the passenger train emergency preparedness planning effort that will be mandated under a separate docket (see 62 FR 8330; February 24, 1997).

This paragraph responds to NTSB concerns announced on June 17, 1997, in adopting its report on the collision of the MARC commuter train with Amtrak's Capitol Limited at Silver Spring, Maryland, and approving related recommendations. Among 13 recommendations to be addressed to FRA was the following:

Require that a comprehensive inspection of all commuter passenger cars be performed to independently verify that the interior materials in these cars meet the expected performance requirements for flammability and smoke emissions characteristics.

The Abstract of Final Report did not include any express finding that materials in the MARC cab car did not meet FTA/FRA criteria for flammability and smoke emission characteristics. However, FRA understands that the full report may point to the introduction of some non-standard materials during

refurbishing and repair of the car. The Board did find as follows:

19. Because other commuter passenger cars may also have interior materials that may not meet specified performance criteria for flammability and smoke emission characteristics, the safety of passengers in those cars could be at risk.

20. The federal guidelines on the flammability and smoke emission characteristics and the testing of interior materials do not provide for the integrated use of passenger car interior materials and, as a result, are not useful in predicting the safety of the interior environment of a passenger car in a fire.

FRA believes that existing fire safety guidelines have continuing value for their specific purpose. Those guidelines are proposed for codification in § 238.115 as the best currently available criteria for analysis of individual materials, and NTSB representatives on the working group have not suggested alternative proposals. However, as explained in the preamble, FRA is conducting research through the National Institute of Standards and Technology to address the interaction of materials and other aspects of fire safety from a broader, systems approach. This philosophy is embodied in proposed § 238.105(a)-(c) with respect to new equipment. Based on this ongoing research, FRA may propose new fire safety performance criteria in the second phase of this rulemaking.

FRA agrees with the Board that steps must be taken to minimize fire safety vulnerabilities in the existing rail passenger equipment fleet. Present fire safety guidelines are advisory and were not introduced by FRA until 1984. Even in recent years, passenger railroads have been free to utilize non-compliant materials (particularly during interior refurbishment funded locally without FTA support). It is appropriate for each commuter authority and Amtrak to evaluate the mix of materials, possible sources of ignition, and potential fire environments—including tunnels, cuts and elevated structures where evacuation to the outside of the vehicle may be difficult or ineffectual in reducing the risk of injury—relevant to the risk of injury due to fire or smoke exposure.

FRA is concerned in particular with the risk arising from the operation of cab cars forward and MU locomotives. Due to their position in the lead of a passenger train, these vehicles are more greatly exposed to the risk of fire from collisions with other rail vehicles as well as highway vehicles at grade crossings. In a collision, fire may erupt from the fuel tanks of both the rail and highway vehicles, and also from tanks

used by highway vehicles that transport loads of flammable material. The level of risk on each railroad corresponds to the number of highway-rail grade crossings, density of rail traffic, and opportunities for collisions.

FRA requests comments on the costs and benefits associated with the approach contained in paragraph (d) should railroads be successful in establishing the categorical framework assumed for the analysis. Is the period of time allowed adequate to complete a review of the existing fleet and differing operating environments? To what extent does available fire safety literature adequately support this undertaking? What difficulties will be faced in identifying the source and current characteristics of interior materials, particularly in older cars and cars that have been transferred from the initial purchaser? In cars that have been refurbished by the railroad's own shop or a contract shop?

§ 238.107 Software safety program. This section provides requirements for the software portion of the system safety program and ties the system safety program to § 238.121, which describes the requirements for software that controls safety features of Tier I or Tier II equipment.

§ 238.109 Inspection, testing, and maintenance program. This section contains the general requirements for the railroad's program for inspecting, testing, and maintaining Tier I equipment. (The inspection, testing, and maintenance program for Tier II equipment is covered under § 238.503.) FRA's goal is a set of standards to ensure that the equipment remains safe as it wears and ages, to protect the workers who perform the inspection, testing, and maintenance tasks, and to provide flexibility enough to allow individual railroads to adapt the maintenance standards to their own unique operating environment. FRA based the proposed requirements on the extensive discussions and information presented in the Working Group meetings.

Paragraph (a) requires a railroad that operates Tier I passenger equipment subject to this part to provide to FRA, if requested, particulars about its inspection, testing, and maintenance program for that equipment, including the following:

- Safety inspection procedures, intervals and criteria; Washington, DC
- Testing procedures and intervals;
- Scheduled preventive maintenance intervals;
- Maintenance procedures; and
- Training of workers who perform the tasks.

Since FRA does not dictate the contents of the program, individual railroads retain much flexibility to tailor the program to their individual needs and experience. At the same time, FRA believes this requirement is an important component of the overall system safety program and the approach will cause railroads to re-examine their inspection, testing, and maintenance procedures to determine that they are adequate to ensure that the safety-related components of their equipment are not deteriorating over time. This approach represents good business practice and in most cases merely formalizes what passenger railroads are already doing. However, FRA believes this section will provide valuable guidance to regional governments or coalitions attempting to establish new commuter rail service.

Paragraph (b) defines broadly the types of conditions that can endanger the safety of the crew, passengers, or equipment that the inspection, testing, and maintenance program should be designed to prevent or to detect and correct. Beyond promulgating and enforcing an extensive set of Federal safety regulations on this subject, FRA is not proposing to specify how a railroad should prevent or detect these conditions. Instead, the proposed standards leave these details to be developed by each individual railroad.

Paragraph (c) establishes a link between scheduled maintenance intervals and the system safety program. Scheduled maintenance intervals should be set so that worn parts are replaced before they fail. Initial intervals should be based on manufacturer's recommendations. As operating experience is gained, FRA believes that accumulated reliability data should be used as the basis for changing preventive maintenance intervals on safety-critical components. This standard will encourage railroads to keep reliability records on safety-critical components that will provide confidence that any safety or economic trade-offs have a firm basis.

Paragraph (d) requires operating railroads to adopt standard operating procedures, in writing, on how to safely perform all safety-critical inspection, testing, and maintenance tasks. This provision is intended to provide protection to the workers who perform these tasks. Inspecting, testing and maintaining rail passenger equipment involves many inherently dangerous tasks. FRA does not intend to prescribe to how to perform these tasks. The proposed standard requires each individual railroad to think through how to safely perform these tasks and to

develop procedures that are safe under its individual set of working conditions. Standard operating procedures can be a key component of a training program to ensure new employees know how to do their jobs safely.

§ 238.111 Training, qualification, and designation program. This section contains the proposed training, qualification, and designation requirements for workers (that is, both railroad employees and contractors as defined in the section) who perform inspection, testing, and maintenance tasks. FRA believes that worker training, qualification, and designation are central to a safe operation.

Labor organizations representing mechanical employees believe that only employees who receive a long-term apprenticeship and on-the-job training—typical of their membership—are qualified to perform inspection, testing, and maintenance tasks. Labor organizations representing operating employees (train crews) believe the work of inspecting and testing is largely outside the scope of work that should be performed by their members, and that railroads do not provide adequate training to their members for them to effectively inspect and test equipment.

Operating railroads believe a different level of skills is needed for simple inspections and tests ("checkers") than is required for trouble-shooting and correction of problems ("maintainers"). As a practical reality, operating railroads make the point that they cannot afford to train their entire inspection, testing, and maintenance work force to be highly-skilled maintainers. Operating railroads claim that operating employees can be easily trained to perform the less complex inspection and testing tasks and in fact have been performing these tasks effectively for years.

Mechanical employee labor organizations counter this point with a strong belief that operating employees—lacking the experience and trained eye of a mechanical employee—perform a cursory inspection that misses defects or problems that would be caught by a mechanical employee.

As a result of these widely different points of view, the Working Group failed to reach overall consensus on the requirements contained in this section. FRA based the proposed requirements on the extensive discussions and information presented in the Working Group meetings as the merits and drawbacks of various approaches to setting the safety standards covered in this section were debated.

Paragraph (a) requires railroads to establish and comply with a training,

qualification, and designation program for employees and contractors who perform safety-related inspection, testing, or maintenance tasks under this part. "Contractor," in this context, means "a person under contract with the railroad or an employee of a person under contract with the railroad." Paragraph (b) lists the steps that must be followed in developing a training, qualification, and designation program.

FRA believes that the list of general requirements enumerated in this section informs railroads what their training, qualification, and designation program must do reasonably to ensure that employees know how to keep the equipment running safely. Most passenger railroads have training programs in place that meet or come close to meeting these proposed requirements. The list of actions that FRA proposes would compel railroads to evaluate their operation and focus their training resources where the need is greatest.

FRA recognizes that some passenger railroads will be forced to place a greater emphasis on training and qualifications than they have in the past, and this requirement will result in additional costs for those railroads. However, the proposed rule allows the railroads the flexibility that they need to provide only that training which an employee needs for a specific job. The proposed rule does not require the "checkers" to receive the intensive training needed for the "maintainers." The training can be tailored to the need. Across the industry as a whole, this proposal will not require extensive changes in the way passenger railroads currently operate. But it will prevent railroads from using minimally trained and unqualified people to perform crucial safety tasks.

Benefits can be gained from this increased investment in training. Better inspections will be performed, resulting in the running of less defective equipment, which translates to a better safety record. Equipment conditions requiring maintenance attention are more likely to be found while the equipment is at a maintenance or yard site where repairs can be more easily done. Trouble-shooting will take less time. More maintenance will be done right the first time, resulting in cost savings due to less rework.

APTA, in commenting on a draft of the NPRM, believes that this section's requirements are overly detailed in scope, content, and record keeping. APTA maintains that broad interpretation of the regulation could lead to arbitrary enforcement resulting in misdirection of training resources. In

addition, APTA contends that the proposal adds costs without a corresponding safety benefit—the cost to develop and implement the training programs and the cost to hire additional work force to perform the duties of those employees attending the required training classes. Commenters are invited to address APTA's concerns.

§ 238.113 Pre-revenue service acceptance testing plan. This section provides requirements for pre-revenue service testing of passenger equipment and ties the system safety program to subpart G, which describes the requirements for the introduction of new technology that could affect safety systems of Tier II passenger equipment. These tests are extremely important in that they are the culmination of all the safety analysis and component tests of the system safety program. The pre-revenue service tests are intended to demonstrate the effectiveness of the system safety program and prove that the equipment can be operated safely in its intended environment.

For equipment that has not previously been used in revenue service in the United States, paragraph (a) requires the operating railroad to develop a pre-revenue service acceptance testing plan and obtain FRA approval of the plan under the procedures stated in § 238.21 before beginning testing. Previous testing of the equipment at the Transportation Test Center, on another railroad, or elsewhere will be considered by FRA in approving the test plan. Paragraph (b) requires the railroad to fully execute the tests required by the plan, to correct any safety deficiencies identified by FRA, and to obtain FRA's approval to place the equipment in revenue service prior to introducing the equipment in revenue service. Paragraph (c) requires the railroad to comply with any operational limitations imposed by FRA. Paragraph (d) requires the railroad to make the plan available to FRA for inspection and copying. Paragraph (e) enumerates the elements that must be included in the plan. FRA believes this set of steps and the documentation required by this section are necessary to ensure that all safety risks have been reduced to a level that permits the equipment to be used in revenue service.

In lieu of the requirements of paragraphs (a) through (e), paragraph (f) provides for an abbreviated testing procedure for equipment that has previously been used in revenue service in the United States. The railroad need not submit a test plan to FRA; however, a description of the testing shall be kept by the railroad and made available to FRA for inspection and copying.

General Requirements

§ 238.115 Fire Safety

Paragraph (a) contains the fire safety requirements for materials used in constructing the interiors of passenger cars and cabs of locomotive ordered on or after January 1, 1999, or placed in service for the first time on or after January 1, 2001. Further, as of the effective date of the final rule, fire safety requirements also apply to materials used in refurbishing the interiors of passenger cars and locomotive cabs. Currently, the rail industry follows FRA's fire safety guidelines as revised on January 17, 1989. See 54 FR 1837. Several Working Group members believe that current fire safety practice has worked well in addressing the flammability of passenger car and locomotive cab interiors. However, since FRA's guidelines were first established, considerable fire safety and fire resistance testing technology has developed and some Working Group members believe that new information is available to improve fire safety.

As discussed earlier in the preamble, FRA is proposing that the existing fire safety guidelines be made mandatory for the construction of new equipment as well as the refurbishing of existing equipment, and they are contained in Appendix B. However, railroads can request, under § 238.21, FRA approval to utilize alternative standards issued or recognized by an expert consensus organization. As part of the second phase of the rulemaking, the Working Group will consider how to apply new fire safety information to improve the fire safety standards, including information being gathered by the NIST and the NFPA.

Paragraph (b) requires railroads to obtain certification that combustible materials to be used in constructing and refurbishing passenger car and locomotive cab interiors have been tested and comply with the fire safety standards as specified in paragraph (a) and Appendix B to this part.

Paragraphs (c) through (e) contain requirements for installing various detection and suppression equipment when shown to be necessary by analyses conducted as part of the fire protection program in § 238.105.

Paragraph (f) requires the railroad to comply with those elements of its written procedures, under § 238.105(12), for the inspection, testing, and maintenance of all fire safety systems and equipment that is has designated as mandatory as part of its fire protection program.

Paragraph (g) requires the railroad, after completing each fire safety analysis

required by § 238.105(d), to take action to reduce the risk of personal injuries due to fire and smoke exposure as provided in § 238.105(d).

§ 238.117 Protection Against Personal Injury

As recommended by the Working Group, this section contains a general requirement to protect passengers and crewmembers from moving parts, electrical shock and hot pipes. This section extends to passenger equipment not classified as locomotives the protection against personal injury which applies to locomotives under 49 CFR 229.41. The proposed requirements represent common-sense safety practice; reflect current industry practice; and should result in no additional cost burden to the industry. These requirements apply to all passenger equipment on or after January 1, 1998.

§ 238.119 Rim-Stamped Straight-Plate Wheels

This section addresses the NTSB's safety recommendation concerning the use of rim-stamped straight-plate wheels on tread-braked rail passenger equipment, as discussed earlier in the preamble. Because a wheel having a rim-stamped straight-plate character is a sufficient safety concern in itself, FRA is extending the NTSB's safety recommendation to apply to all such wheels used on passenger equipment regardless whether the equipment is tread-braked or not.

§ 238.121 Train System Software and Hardware

This section contains the proposed requirements for the hardware and software that controls train safety functions that is ordered on or after January 1, 1999, and such systems implemented or materially modified for new or existing equipment on or after January 1, 2001. This section reflects the growing role of automated systems to control passenger train safety functions. FRA had presented for consideration a rather complex set of software safety requirements in the ANPRM, but the Working Group recommended simplifying these requirements and combining them with the requirements for the hardware components of control systems.

Paragraph (a) proposes a requirement for a formal safety methodology that includes a Failure Modes, Effects, Criticality Analysis (FMECA) and full verification tests for all components of safety system controls. A formal safety analysis that includes full verification is now standard practice for safety systems that contain software components.

In paragraph (b), FRA proposes to require a comprehensive hardware and software integration testing program to ensure that the hardware and the software installed in the hardware function together as intended. Again, this is a practice that has become common for critical control systems that include both software and hardware.

Paragraph (c) contains a provision for safety-related control systems driven by computer software to have design features that result in a safe condition in the event of a computer hardware or software failure. This is a design feature that is used in aircraft and in weapon control systems.

These requirements are not complex and will not limit the flexibility of equipment designers. Yet, they reflect good design practices that have led to reliable, safe computer hardware and software control systems in other industries. Computer hardware and software systems designed to these requirements may require a larger initial investment to develop, but experience in other industries has shown that this investment is quickly recovered by significantly reducing hardware and software integration problems and minimizing trouble-shooting and debugging of equipment.

§ 238.123 Emergency Lighting

Experience gained during rescues conducted after recent passenger train accidents indicates that emergency lighting systems either did not work or failed after a short time, greatly hindering rescue operations. This section requires that passenger cars and locomotives ordered or rebuilt on or after January 1, 1999, or placed in service for the first time on or after January 1, 2001, be equipped with emergency lighting providing a minimum average illumination level of 5 foot-candles at floor level for all potential evacuation routes and a back-up power feature capable of operation for a minimum of two hours after loss of normal power. Although members of the Working Group advised that the lighting intensity requirement be 0.05 foot-candle, FRA does not believe that 0.05 foot-candle provides enough illumination for passengers to locate emergency exits, read instructions for their operation, and operate the exits, as demonstrated by Volpe Center staff at a Working Group meeting in December, 1996. FRA requests comments whether the lighting intensity requirement need be 5 foot-candles at floor level for all potential evacuation routes if the rail vehicle has a combination of lower intensity floor proximity lighting, similar to that used on aircraft to mark

the exit path, and higher intensity lighting at the vehicle's exits.

FRA is considering requiring that emergency lighting meeting the requirements of this section be implemented in existing passenger equipment sooner than when the equipment is rebuilt. Existing passenger equipment may not be rebuilt for 20 years or more. FRA therefore invites comments whether the proposed requirements should be implemented in existing passenger equipment within a specified time such as 5 years.

The two-hour time duration for availability of back-up power is based on experience gained during rescue operations for passenger train accidents in remote locations. In such accidents, fully-equipped emergency response forces can take an hour or more to arrive at the site, and additional time is required to deploy and reach people trapped or injured in the train. In addition, the back-up power system must be able to operate in all orientations within 45 degrees of vertical and after experiencing a shock due to a longitudinal acceleration of 8g and vertical and lateral accelerations of 4g. The shock requirement will ensure that the back-up power system has a reasonable chance of operating after the initial shock caused by a collision or derailment. FRA originally considered that the back-up power system be capable of operation within a vehicle in any orientation. However, members of the Working Group advised that some battery technologies utilize a liquid electrolyte which can leak when the battery is tilted. FRA is further considering whether the back-up power system should be made capable of operation within a vehicle in any orientation, including allowing railroads to continue using any existing batteries through their permanent life before implementing such a requirement on replacement batteries. Commenters are requested to address this issue.

FRA is further investigating emergency lighting requirements as part of a systems approach to effective passenger train evacuation through a research study to be performed by the Volpe Center. FRA welcomes input from knowledgeable persons as to what emergency lighting requirements would be appropriate for passenger trains to assist in passenger evacuation.

Subpart C—Specific Requirements for Tier I Passenger Equipment

§ 238.201 Scope

This subpart contains specific requirements for railroad passenger equipment operating at speeds not

exceeding 125 mph. Unless otherwise specified in the discussion of this subpart and with the following qualifications, the proposed requirements represent the consensus recommendations of the Working Group. FRA has proposed the specific implementation dates for these requirements. Additionally, in structuring the rule FRA has specified the type of equipment subject to each requirement more finely than in the Working Group's recommendations, while at the same time reflecting those recommendations as closely as possible. Further, FRA has made other changes to the recommendations to make the proposed requirements more clear, enforceable, and compatible with other rail safety laws.

Structural standards for new equipment. Unless otherwise specified, the requirements of this subpart apply only to passenger equipment ordered on or after January 1, 1999, or placed in service for the first time on or after January 1, 2001.

The proposed rule also provides that passenger equipment placed in service for the first time on or after January 1, 1998, unless otherwise provided in the cited sections, must meet the minimum structural requirements specified in: §§ 238.203 (static end strength); 238.205(a) (anti-climbing mechanism); 238.207 (link between coupling mechanism and car body); and 238.211(a) (collision posts). Together, these four proposed requirements are virtually identical to existing Federal requirements, found in 49 CFR 229.141(a)(1)–(4), that apply to MU locomotives built new after April 1, 1956, and operated in trains having a total empty weight of 600,000 pounds or more. These proposed requirements reflect the current construction practice for North American passenger equipment, and FRA believes they are minimum safety requirements for new equipment.

In addition to the structural requirements identified above, the proposed rule also requires that passenger equipment ordered on or after January 1, 1999, or placed in service for the first time on or after January 1, 2001, unless otherwise provided in the cited sections, comply with other structural requirements specified in: §§ 238.205(b) (anti-climbing mechanism for locomotives); 238.209 (forward-facing end structure of locomotives); 238.211(b) (collision posts for locomotives); 238.213 (corner posts); 238.215 (rollover strength); 238.217 (side impact strength); 238.219 (truck-to-car-body attachment); and 238.223 (fuel tanks).

Structural standards for existing equipment. The proposed rule would require that passenger equipment (other than private cars, or vehicles of a special design operating at the rear of a passenger train and used solely to transport freight) in use on or after January 1, 1998, have a minimum static end strength of 800,000 pounds (§ 238.203). Static end strength is critical in protecting passenger equipment from crushing in a head-on or rear-end collision, especially in the North American railroad operating environment that includes frequent highway-rail grade crossings and the mixed operation of freight and passenger trains.

FRA is confident that existing North American passenger cars have been built to basic compressive strength requirements. Beginning in 1939, the AAR recommended that new passenger cars operated in trains of over 600,000 pounds empty weight have a minimum static end strength of 800,000 pounds, and since 1956, Federal Regulations (49 CFR 229.141) require that new MU locomotives operated in such trains must meet this standard.

FRA is considering requiring that one or more of the other structural requirements for new passenger equipment, discussed above, be made applicable to existing equipment as soon as one of the following events occurs: the equipment is sold to another railroad; the equipment is rebuilt; the equipment reaches 40 years of age; or 10 years after the effective date of the rule. FRA invites comments on: (1) what equipment would be affected by each of these structural requirements; (2) the feasibility and costs of retrofitting such equipment, with costs broken out for each of the different structural requirements, in the event such triggering events were adopted in the final rule; (3) whether these triggering events are reasonable, or whether some other fixed deadline should be established for making one or more of these structural requirements applicable to existing passenger equipment; and (4) the safety benefits that could accrue by making these requirements applicable to existing equipment.

FRA notes that older passenger equipment may not meet the collision post requirements in § 238.211(a) because of a change in collision post design following a collision between two Illinois Central Gulf Railroad commuter trains in Chicago, Illinois, on October 30, 1972. Moreover, APTA is opposed to making structural requirements applicable to existing equipment. In particular, APTA has advised FRA that a significant number

of such equipment either may not meet the structural requirements in §§ 238.203, 238.205(a), 238.207, and 238.211(a), or the equipment must undergo potentially costly testing to determine whether the requirements are met. FRA will discuss with the Working Group alternatives that would avoid unnecessary expense to document design features of older equipment.

No new safety appliance requirements. FRA is not proposing new safety appliance requirements for passenger equipment subject to this subpart. The safety appliance requirements referenced in § 238.229 continue to apply to such passenger equipment and are noted in this rule for clarity, on the advice of the Working Group.

§ 238.203 Static End Strength

This section contains the requirements for the overall compressive strength of rail passenger equipment. The proposed requirements make mandatory the long-standing, North American design practice of specifying a minimum static end strength of 800,000 pounds, and a minimum static end strength of 800,000 pounds in the line of draft at the ends of occupied volumes, without permanent deformation of the car body structure. This requirement has proven effective in the North American railroad operating environment that includes frequent highway-rail grade crossings, mixed operation of freight and passenger trains, and less than fully-capable signal and train control systems. The requirement is effective on or after January 1, 1998. Although FRA would prefer that every vehicle in a passenger train have a minimum static end strength as specified in this section, FRA recognizes that imposing this requirement universally may effectively prohibit the use of some private cars and all auto-carriers and RoadRailer equipment.

To prevent sudden, brittle-type failure of the main structure of passenger equipment, the proposed rule requires that the body structure be designed, to the maximum extent possible, to fail by buckling or crushing, or both, of structural members rather than by fracture of structural members or failure of structural connections. To allow a crash energy management design approach to be employed, this requirement applies only to the occupied volume of the equipment. Unoccupied volumes may have a lesser static end yield strength.

§ 238.205 Anti-Climbing Mechanism

This section contains the vertical strength requirements for anti-climbing mechanisms on rail passenger equipment. The purpose of the anti-climbing mechanism is to prevent override or telescoping of one passenger train unit into another in the event of high compressive forces caused by a derailment or collision.

FRA is proposing that all passenger equipment placed in service for the first time on or after January 1, 1998, shall have an anti-climbing mechanism at each end capable of resisting an upward or downward vertical force of 100,000 pounds without permanent deformation. When coupled together in any combination to join two vehicles, AAR Type H and Type F tight-lock couplers satisfy this requirement. This requirement incorporates a long-standing industry practice into the proposed rule.

The proposed rule further requires that the forward end of a locomotive ordered on or after January 1, 1999, or placed in service for the first time on or after January 1, 2001, be equipped with an anti-climbing mechanism capable of resisting an upward or downward vertical force of 200,000 pounds without failure. This requirement applies to locomotives or power cars of permanently coupled trains. AAR Standard S-580, which addresses the crashworthiness of locomotives, has included this requirement for all locomotives built since August 1990. FRA believes this industry practice represents sound equipment design.

§ 238.207 Link Between Coupling Mechanism and Car Body

This section contains the vertical strength requirements for the structure that links the coupling mechanism to the car body on passenger equipment. The purpose of this requirement is to avoid a premature failure of the draft system so that the anti-climbing mechanism will have an opportunity to engage.

FRA is proposing that all passenger equipment placed in service for the first time on or after January 1, 1998, be provided with a coupler carrier or other coupler-to-car-body linking structure that is designed to resist a vertical downward thrust from the coupler shank of 100,000 pounds, without permanent deformation for any normal horizontal position of the coupler.

§ 238.209 Forward-Facing End Structure of Locomotives

This section contains the requirement for the covering or skin of the forward-

facing end structure of each passenger locomotive ordered on or after January 1, 1999, or placed in service for the first time on or after January 1, 2001. The purpose of this requirement is to protect the occupied area of a locomotive cab, which is especially vulnerable in a highway-rail grade crossing collision if a fuel tank that is part of or being transported by a highway vehicle ruptures.

FRA is proposing that the skin covering the forward-facing end of each passenger locomotive, *e.g.*, a cab car and an MU locomotive, be equivalent to a 1/2-inch steel plate with a 25,000 pounds-per-square-inch yield strength and be designed to inhibit the entry of fluids into the occupied area of the equipment. Higher yield strength material may be used to decrease the required thickness of the material provided an equivalent strength is maintained. AAR Standard S-580 has included this requirement for all locomotives built since August 1990. From observations of the improved performance of locomotives during collisions, FRA believes that this industry standard should become part of the proposed safety standards.

§ 238.211 Collision Posts

This section contains the structural strength requirements for collision posts. Collision posts provide protection against the crushing of occupied areas of passenger equipment in the event of a collision or derailment. This section does not apply to a vehicle of special design that operates at the rear of a passenger train and is used solely to transport freight, such as an auto-carrier or RoadRailer.

Paragraph (a) requires that all passenger equipment placed in service for the first time on or after January 1, 1998, shall have either two full-height collision posts at each end where coupling and uncoupling are expected, each collision post having an ultimate longitudinal strength of not less than 300,000 pounds; or an equivalent end structure.

The proposed 300,000-pound strength requirement makes mandatory the long-standing North American passenger equipment design practice for collision posts. This requirement has proven effective in the North American railroad operating environment. This requirement is similar to that contained in 49 CFR 229.141(a)(4), which applies to MU locomotives operated in trains having a total empty weight of 600,000 pounds or more, but also requires the collision posts to be full-height. Full-height collision posts provide additional protection because they extend higher

than posts attached only at the underframe. Little, if any, additional cost is imposed on builders by requiring full height posts. The spacing at approximately the one-third points laterally will allow both collision posts to be engaged in many collision scenarios. An equivalent single rear end structure may be used in place of the two collision posts provided it can withstand the sum of the forces that each collision post is required to withstand.

Paragraph (b) requires that each locomotive ordered on or after January 1, 1999, or placed in service for the first time on or after January 1, 2001, have two forward collision posts, located at approximately the one-third points laterally, each capable of withstanding a 500,000-pound longitudinal force without exceeding the ultimate strength of the joint. In addition, each post must be capable of withstanding a 200,000-pound longitudinal force exerted 30 inches above the joint of the post to the underframe, without exceeding its ultimate strength. AAR Standard S-580 has included this requirement for all locomotives built since August 1990. From observation of the improved performance of these locomotives during collisions, FRA believes this industry practice should become part of the proposed safety standards.

As an option, an equivalent end structure may be used in place of the two forward collision posts. The single end structure shall withstand the sum of the forces that each collision post is required to withstand. This option is proposed to allow for the design of unitized or aircraft-type structures.

FRA is proposing that collision posts be required at the ends of passenger equipment where coupling and uncoupling are expected or where separation is likely in the event of a violent derailment. Paragraph (c) provides that if a train is made up of vehicles with articulated units, collision posts are required only at the ends of the permanently joined assembly of units, not at the ends of each unit of the assembly. Articulated units are not likely to experience impacts on other than the outside ends of the assembly.

§ 238.213 Corner Posts

This section contains the requirements for corner posts on passenger cars, *e.g.*, passenger coaches, cab cars and MU locomotives.

A corner post is the vertical structural member normally located at the intersection of the end of a rail vehicle with a side of that vehicle. However, FRA intends for the proposed rule to allow flexibility so that the corner post

may be located at positions other than the extreme outside corner of a vehicle. For example, on cars equipped with end vestibules, the corner posts may be located in the side structure inboard of the side door opening.

The structural parameters proposed for corner post strength represent the current design practice for passenger cars built for North American service. They are being proposed as an interim measure to prevent the introduction of equipment not meeting such requirements. FRA recognizes that current design practice has proven inadequate to protect the occupied volume in several recent side-swipe collisions involving passenger trains with cab cars leading. Crash modeling suggests that it is not feasible to protect against collisions of the magnitude that occurred at Secaucus, New Jersey, and Silver Spring, Maryland, in February of 1996. Nevertheless, stronger corner posts are necessary to address collisions involving lower closing speeds, and determining what may be feasible in terms of cost and weight will be a priority in the second phase of the rulemaking.

§ 238.215 Rollover Strength

This section contains the structural requirements intended to prevent significant deformation of the normally occupied spaces of a passenger car in the event it rolls onto its side or roof. The proposal essentially requires the vehicle structure to be able to support twice the dead weight of the vehicle while the vehicle is resting on its side or roof. Deformation of sheathing and framing is allowed to the extent necessary for the vehicle to be supported directly by more substantial structural members of the frame, including the top chords and side frames. Analysis has shown that current passenger car design practice meets this requirement. This requirement has proven effective in preventing massive structural deformation of cars that have rolled during collisions or derailments. For this reason, FRA believes this requirement should be incorporated into the proposed safety standards.

FRA invites comment on whether this requirement should also apply to locomotives. Representatives from RPI advised that locomotives do not roll over frequently enough to justify such requirements for locomotives. Nevertheless, even if a locomotive does not roll over, this requirement should help protect its roof from crushing if it is forced to support the weight of another vehicle thrown onto its roof in an accident.

§ 238.217 Side Impact Strength

This section contains the car body strength requirements intended to resist penetration of the side structure of a passenger car by a highway or rail vehicle.

FRA believes that a side impact strength requirement is necessary because approximately 14% of the grade crossing accidents involving a passenger train result from a highway vehicle striking the side of the passenger train. In addition, during a derailment or train-to-train collision, trains frequently buckle, exposing the sides of cars to potential impacts during the collision. The proposed requirement was an AAR recommended design practice for passenger cars, as last revised in 1984, and represents current North American design practice.

In designing a side impact strength requirement for a passenger car, the objective is to cause the side of the passenger car to be strong enough so that the car derails rather than collapses when struck in the side by another rail vehicle or a heavy highway vehicle. FRA believes that current design practice may not be adequate to meet this goal. FRA also believes that cars with low floors, such as bi-level equipment, are particularly vulnerable to penetration when struck in the side. A more meaningful side impact strength requirement is necessary and will be a priority in the second phase of the rulemaking, as research determines what may be feasible in terms of cost and weight. The proposed requirement is therefore an interim measure to prevent the introduction or use of equipment not meeting this basic strength requirement.

§ 238.219 Truck-to-Car-Body Attachment

This section contains the truck-to-car-body attachment strength requirement for passenger equipment. The attachment is required to resist without failure a 2g vertical force on the mass of the truck and a force of 250,000 pounds in any horizontal direction. The requirement for the attachment to resist a horizontal force is intended to allow the truck to act as an anti-climbing device during a collision. With the truck attached to the car body, the truck of an overriding rail vehicle is likely to be caught by the underframe of the overridden rail vehicle, thus arresting the override. The parameter selected represents the current design practice that has proven effective in preventing horizontal shear of trucks from car bodies.

The requirement for the attachment to resist a vertical force is intended to keep the truck attached if the car body is raised or rolls over. If the truck remains attached to the car body, the truck is less likely to be struck by other units of the train. The attachment must resist, without failure, a force equal to twice the weight of the truck and all the components attached to the truck. Many types of keepers are used to keep trucks attached to car bodies. FRA believes that the majority of them are capable of meeting this requirement.

§ 238.221 Glazing

FRA is proposing additional requirements concerning the safety glazing of passenger equipment subject to the requirements of 49 CFR part 223. Existing safety glazing requirements for windows have largely proven effective in passenger service at speeds up to 125 mph. However, part 223 does not address the performance of the frame which attaches the glazing to the car body. This section requires the glazing frame to be capable of holding the glazing in place against all forces which the glazing is required to resist under part 223. In addition, the glazing frame must hold the glazing in place against the forces created by air pressure differences caused when two trains pass at their maximum authorized speeds in opposite directions at the minimum track separation for two adjacent tracks. This requirement is intended to prevent the glazing from being forced from the window opening and potentially injuring passengers and crewmembers. FRA that believes most existing passenger equipment subject to part 223 meets these requirements. However, they should not be left to chance and need to be required in the equipment design.

§ 238.223 Fuel Tanks

This section contains the structural requirements for external and integral fuel tanks on locomotives ordered on or after January 1, 1999, or placed in service for the first time after January 1, 2001. A discussion of fuel tank safety issues is provided above.

External fuel tanks must comply with AAR Recommended Practice-506, Performance Requirements for Diesel Electric Locomotive Fuel tanks. FRA believes that RP-506 represents an improvement in fuel tank crashworthiness and should be incorporated into the proposed standards. Labor representatives on the Working Group object to a direct incorporation of industry standards that effectively allow an industry organization to change a Federal safety

standard by changing the industry standard. FRA agrees and is proposing that the rule incorporate the industry standard as adopted on July 1, 1995.

§ 238.225 Electrical System

This section contains the proposed requirements for the design of electrical systems on passenger equipment. The Working Group advised that no single, well-recognized electrical code or set of standards applied directly to the design of railroad passenger equipment. As a result, the Working Group recommended broad performance requirements which reflect common electrical safety practice and are widely recognized as good electrical design practice. FRA had offered for comment more detailed electrical system design requirements in the ANPRM, but as advocated by the Working group the proposed rule is more performance-oriented and provides wide latitude in equipment design. FRA believes that this approach helps to ensure good electrical design practice without imposing unnecessary costs on the industry.

The electrical system requirements include provisions for:

- Electrical conductor sizes and properties to provide a margin of safety for the intended application;
- Battery system design to prevent the risk of overcharging or accumulation of dangerous gases that can cause an explosion;
- Design of resistor grids that dissipate energy produced by dynamic braking with sufficient electrical isolation and ventilation to minimize the risk of fires; and
- Electromagnetic compatibility within the intended operating environment to prevent electromagnetic interference with safety-critical equipment systems and to prevent interference of the rolling stock with other systems along the rail right-of-way.

§ 238.227 Suspension System

This section contains the proposed requirements for suspension system performance of all Tier I passenger equipment on or after January 1, 1998, and represents the minimum requirements for a safe operation. In the ANPRM, FRA presented for comment a large set of fairly detailed suspension system performance requirements very similar to those now being proposed for Tier II passenger equipment. The Working Group advised that such an extensive set of requirements was not needed for Tier I passenger equipment.

Overall, FRA is proposing that all passenger equipment shall exhibit

freedom from hunting oscillations at all speeds. Further, FRA is proposing particular suspension system safety requirements for passenger equipment operating at speeds above 110 mph but not exceeding 125 mph, near the transition speed range from Tier I to Tier II requirements. Although FRA believes that for speeds not exceeding 110 mph existing equipment has not demonstrated serious suspension system stability problems, most of this same equipment is only operated at speeds that do not exceed 110 mph. Accordingly, when new or existing passenger equipment is intended for operation above 110 mph, this equipment must demonstrate stable operation during pre-revenue service qualification tests at all speeds up to 5 mph in excess of its maximum intended operating speed under worst-case conditions—including component wear—as determined by the operating railroad. The Working Group advised FRA that a single definition of worst-case conditions could not be applied generally to all railroads; and, as a result, the definition of worst-case conditions shall be determined by each railroad based upon its particular operating environment.

§ 239.229 Safety Appliances

This section references current safety appliance requirements contained in 49 U.S.C. chapter 203 and 49 CFR part 231. These existing requirements continue to apply independently to all Tier I passenger equipment, and FRA is referencing them here for clarity on the recommendation of the Working Group.

§ 238.231 Brake System

This section contains general brake system performance requirements that apply on or after January 1, 1998, to Tier I passenger equipment except as otherwise provided. Although the Working Group did not reach consensus on these proposed requirements due to the inability of the group to resolve the brake inspection, testing, and maintenance issues, the proposed provisions had widespread support among many of the members of the Working Group. Several of the proposed requirements contained in this section were included in written positions provided by both rail labor and management members of the Working Group. Virtually all of the proposed provisions were discussed in the 1994 NPRM on power brakes. See 59 FR 47676.

Paragraph (a) contains a requirement that the primary braking system be capable of stopping the train with a service application of the brakes from its

maximum authorized operating speed within the signal spacing existing on the track. FRA believes that this proposed requirement is the most fundamental performance standard for any train brake system. This section merely codifies a requirement which is current industry practice and is the basis for safe train operation in the United States.

Paragraph (b) requires that passenger equipment ordered on or after January 1, 1999, or placed in service for the first time on or after January 1, 2001, be designed not to require an inspector to place himself or herself on, under, or between components of the equipment to observe brake actuation or release. The proposal allows railroads the flexibility of using a reliable indicator in place of requiring direct observation of the brake application or piston travel because the current designs of many passenger car brake systems make direct observation extremely difficult without the inspector placing himself or herself underneath the equipment. Brake system piston travel or piston cylinder pressure indicators have been used with satisfactory results for many years. Although indicators do not provide 100 percent certainty that the brakes are effective, FRA believes that they have proven themselves effective enough to be preferable to requiring an inspector to assume a dangerous position.

Paragraph (c) proposes to require that an emergency brake application feature be available at any time and that it produce an ir retrievable stop. This section merely codifies current industry practice and ensures that passenger equipment will continue to be designed with an emergency brake application feature. In the 1994 NPRM on power brakes, FRA proposed a requirement that all trains be equipped with an emergency application feature capable of increasing the train's deceleration rate a minimum of 15 percent. See 59 FR 47729. Comments received in response to that proposal indicated that passenger brake equipment should provide a deceleration rate with a full service application that is close to the emergency brake rate and that the proposed requirement would require the lowering of full service brake rates, thereby compromising safety and lowering train speeds. Based on these comments, FRA proposes the current requirement which is in accordance with suggestions made by several passenger operations.

Paragraph (d) proposes to require that the train brake system respond as intended to brake control signals and that the brake control system be designed so that a loss of control signal causes a redundant control to take over

or cause the brakes to apply. These proposed provisions are fundamental requirements necessary for effective brake system performance, and a codification of current industry practice. FRA intends the requirement to apply to all types of brake control signals, including pneumatic, electric, and radio signals.

Paragraph (e) proposes to prohibit the introduction of alcohol or other chemicals into the brake line. During periods of extreme cold weather, railroad employees at times resort to adding alcohol or other freezing point depressants to the brake line in an attempt to prevent accumulated moisture in the line from freezing. Virtually every railroad has a policy against this practice because alcohol and other chemicals attack the o-rings and gaskets that seal the brake system, causing them to age or fail prematurely. This practice can lead to dangerous air leaks and it increases maintenance costs. FRA proposed a similar requirement in the 1994 NPRM on power brakes and received numerous comments supporting this provision. See 59 FR 47728.

Paragraph (f) proposes to require that the brake system be designed and operated to prevent dangerous cracks in wheels. Passenger equipment wheels are normally heat treated so that the wheel rim is in compression. This condition forces small cracks that form in the rim to be closed. Heavy tread braking can heat wheels to the point that a stress reversal occurs and the wheel rim is in tension to a certain depth. Rim tension is a dangerous condition because it promotes surface crack growth. In the 1994 NPRM on power brakes, FRA proposed a wheel surface temperature limit to prevent this condition. See 59 FR 47729. Several brake manufacturers and railroads objected to this approach, claiming that the temperature limit was too conservative and did not allow for the development of new materials that can withstand higher temperatures. Based on these comments and concerns, FRA is proposing a more flexible performance requirement rather than a wheel tread surface temperature limit. This is an extremely important safety requirement because a cracked wheel that fails at high speed can have catastrophic consequences. In addition, the proposed requirement will lead to longer wheel life, and thus should provide maintenance savings to the railroads.

Paragraph (g) proposes to require that brake discs be designed and operated so that the disc surface temperature does not exceed manufacturer recommendations. In the 1994 NPRM,

FRA proposed a disc surface temperature limit. See 59 FR 47729. As noted above, several brake manufacturers and railroads objected to this approach, claiming that the temperature limit was too conservative and did not allow for the development of new materials that can withstand higher temperatures. Based on these comments and concerns, FRA proposes a more flexible requirement rather than a single disc surface temperature limit. FRA believes this requirement will lead to longer disc life, and thus will produce maintenance savings to railroads.

Paragraph (h) proposes to require that, except for a locomotive that is ordered before January 1, 1999, and placed in service for the first time before January 1, 2001, and except for a private car, all passenger equipment shall be equipped with a hand or parking brake that can be set and released manually and can hold the equipment on the maximum grade anticipated by the operating railroad. A hand or parking brake is an important safety feature that prevents the rolling or runaway of parked equipment. The proposed requirement represents current industry practice. In the 1994 NPRM on power brakes, FRA proposed requiring that a hand brake be equipped on cars and locomotives. See 59 FR 47729. FRA received several comments to that proposal suggesting that the term "parking brake" be added to the requirement since that is what is used in many passenger operations. Based on those suggestions, FRA has added the term in this proposal.

Paragraph (i) proposes to require that passenger cars be equipped with a means for the emergency brake to be applied that is clearly identified and accessible to passengers. This is a longstanding industry practice and an important safety feature because crucial time may be lost requiring passengers sensing danger to find a member of the train crew to stop the train.

Paragraph (j) contains proposed provisions to ensure that the dynamic brake does not become a safety-critical device. Railroads have consistently held that dynamic brakes are not safety devices because the friction brake alone is capable of safely stopping a train if the dynamic brake is not available. The proposed provisions include requiring that the blending of the friction and dynamic brakes be automatic, that the friction brakes alone be able to stop the train in the allowable stopping distance, and that a failure of the dynamic brake does not cause thermal damage to wheels or discs due to the greater friction braking load. FRA believes that without these requirements the dynamic

brake would most likely become a safety-critical item and railroads would not be permitted to dispatch trains unless the dynamic brake were fully operational.

Paragraph (k) proposes to require that either computer modeling or dynamometer tests be performed to confirm that new brake designs not result in thermal damage to wheels or discs. Further, if the operating parameters of the new braking system change significantly, a new simulation must be performed. This proposal provides a means to ensure that the requirements proposed in paragraphs (f) and (g) are being complied with by new brake designs.

Paragraph (l) proposes to require that all locomotives ordered on or after January 1, 1999, or placed in service for the first time on or after January 1, 2001, be equipped with effective air coolers or air dryers on those locomotives that are equipped with air compressors. The coolers or dryers must be capable of providing air to the main reservoir with a dew point suppression at least 10 degrees F. below ambient temperature. FRA and most members in the industry agree that moisture is a major cause of brake line contamination. Consequently, reducing moisture leads to longer component life and better brake system performance. Currently, virtually all passenger railroads purchase only locomotives equipped with air dryers or coolers. Therefore, FRA proposes to require the continuation of what it believes is good industry practice.

§ 238.233 Interior Fittings and Surfaces

This section contains proposed requirements concerning interior fittings and surfaces that apply, as specified in this section, to passenger cars and locomotives ordered on or after January 1, 1999, or placed in service for the first time on or after January 1, 2001. This section should be read in connection with an earlier discussion of train interior safety features in the preamble.

FRA and NTSB investigations of passenger train accidents have revealed that luggage, seats, and other interior objects breaking or coming loose is a frequent cause of injury to passengers and crewmembers. During a collision, the greatest decelerations and thus the greatest forces to cause potential failure of interior fitting attachment points are experienced in the longitudinal direction, *i.e.*, in the direction parallel to the normal direction of train travel. Current practice is to design seats and other interior fittings to withstand the forces due to accelerations of 6g in the longitudinal direction, 3g in the vertical

direction, and 3g in the lateral direction. Due to the injuries caused by broken seats and other loose fixtures, FRA believes that the current design practice is inadequate.

Accordingly, paragraph (a) proposes that each seat in a passenger car remain firmly attached to the car body when subjected to individually applied accelerations of 4g in the vertical direction and 4g in the lateral direction acting on the deadweight of the seat or seats, if a tandem unit. In addition, the attachment must resist a longitudinal inertial force of 8g acting on the mass of the seat plus the impact force of the mass of a 95th-percentile male occupant(s) being decelerated from a relative speed of 25 mph and striking the seat from behind. By resisting the force of an occupant striking the seat from behind, a potential domino effect of seats breaking away from their attachments is avoided.

Paragraph (b) proposes that overhead storage racks provide longitudinal and lateral restraint for stowed articles to minimize the potential for these objects to come loose and injure train occupants. Further, to prevent overhead storage racks from breaking away from their attachment points to the car body, these racks shall have an ultimate strength capable of resisting individually applied accelerations of 8g longitudinally, 4g vertically, and 4g laterally acting on the mass of the luggage stowed. This mass shall be specified by each railroad. Paragraph (c) requires that all other interior fittings in a passenger car be attached to the car body with sufficient strength to withstand individually applied accelerations of 8g longitudinally, 4g vertically, and 4g laterally acting on the mass of the fitting. FRA believes the proposed attachment strength requirements for seats, overhead storage racks, and other interior fittings will help reduce the number of injuries to occupants in passenger cars.

Passenger car occupants may also be injured by protruding objects, especially if the occupants fall or are thrown against such objects during a train collision or derailment. As a result, FRA is proposing in paragraph (d) that, to the extent possible, all interior fittings in a passenger car, except seats, shall be recessed or flush-mounted. Such fittings do not protrude above interior surfaces and thereby help to minimize occupant injuries.

Paragraph (e) is a general, common sense prohibition against sharp edges and corners in a locomotive cab and a passenger car. Just as FRA is concerned about protruding objects, these surfaces could also injure passenger train

occupants. If sharp edges and corners cannot be avoided, they should be padded to mitigate the consequences of occupant impacts.

Paragraph (f) contains the requirements for floor-mounted cab seats provided solely for the crewmembers in locomotive cabs. FRA proposes to require the seat attachment to have an ultimate strength capable of resisting the loads due to individually applied accelerations of 8g longitudinally, 4g vertically, and 4g laterally acting on the combined mass of the seat and its occupant. This requirement is more stringent than the requirement for seats in passenger cars in paragraph (a) because the mass of the seat occupant is included in determining the load that must be resisted. Cab seats designed to this requirement will allow the use of seat belts and shoulder harnesses to restrain crewmembers in a collision. Further, when turned backwards during a collision, seats designed to this requirement can effectively restrain crewmembers.

§ 238.235 Emergency Window Exits

This section should be read with the earlier discussion of emergency window exits in the preamble. With the exception of paragraph (b), the requirements in this section are applicable to passenger cars on or after January 1, 1998, thereby including existing passenger cars. However, the emergency window exit size requirements in paragraph (b) are only applicable to passenger cars placed in service for the first time on or after January 1, 1998. APTA has advised FRA that not all emergency window exits on existing passenger cars meet the size requirements of paragraph (b), and FRA invites comment on this point.

This section requires that a single-level passenger car, other than a passenger car of special design, have a minimum of four emergency window exits, either in a staggered configuration or with one located at each end of each side of the car. A bi-level car shall have a minimum of four emergency window exits on each main level, configured as above, so that the car has a minimum total of eight emergency window exits. Safety may be advanced by staggering the configuration of emergency window exits so that the window exits are located diagonally across from each other on opposite sides of a car, instead of placing them directly across from each other. Commenters are invited to address this issue. In addition, concern has been raised that the seat arrangement of passenger cars may block access to and the removal of

emergency window exits. Commenters are also requested to address this issue.

FRA is proposing that each passenger car of special design, such as a sleeper car, have at least one emergency window exit in each compartment. Occupants of a sleeper car may have difficulty reaching the car doors quickly in an emergency from their compartments, for example, if an emergency window exit is not provided in their individual sleeping compartments. An emergency window exit is necessary in each compartment to enable occupants to quickly exit the car when time is of the essence, especially if the car is submerged.

Each emergency window exit must be easily operable by a 5th-percentile female without requiring the use of a tool or other implement. FRA has added to the Working Group's recommendation by specifying that a 5th-percentile female must be able to easily operate the emergency exit, thereby making clear the degree to which the exit need be easily operable by members of the general public. FRA believes this is consistent with the desire of the Working Group to promote the safety of the travelling public.

Paragraph (f) is reserved for emergency window exit marking and operating instruction requirements. These requirements are currently being addressed in the proposed rule on passenger train emergency preparedness. See 62 FR 8330, Feb. 24, 1997.

§ 238.237 Doors

This section contains the requirements for exterior side doors on passenger cars. These doors are the primary means of egress from a passenger train. This section should be read in connection with the preamble discussion of NTSB safety recommendation (R-96-7) arising from the 1996 Silver Spring, Maryland accident.

Paragraph (a) requires that within two years of the effective date of the final rule, each powered, exterior side door in a vestibule that is partitioned from the passenger compartment of a passenger car shall be equipped with a manual override that is: capable of opening the door without power from inside the car; located adjacent to the door which it controls; and designed and maintained so that a person may access the override device from inside the car without requiring the use of a tool or other implement. Passenger cars subject to this requirement that are not already equipped with such manual override devices must be retrofitted accordingly. As noted above, FRA's proposal is not

a consensus recommendation of the Working Group.

FRA invites comment on whether the location of the manual override device should be specified in terms of distance from the door it controls or some other measure. FRA is proposing that the manual override device be "adjacent" to the door, as stated in the NTSB safety recommendation. Railroad representatives on the Working Group have suggested a time performance requirement that includes the time necessary for locating and opening the door.

Currently, there is no Federal requirement that passenger cars be equipped with side doors. Accordingly, in paragraph (b) FRA is proposing that passenger cars ordered on or after January 1, 1999, or placed in service for the first time on or after January 1, 2001, shall have a minimum of four side doors, or the functional equivalent, each permitting at least one 95th-percentile male to pass through at a single time. Although the Working Group did not discuss this proposal, FRA believes that such a requirement is necessary, at least as an interim measure, so that each passenger car have sufficient doorway openings to allow passengers to quickly exit in a life-threatening situation. Exiting a passenger car through a window exit is slower.

FRA recognizes that existing designs of passenger cars do not always provide for four side doors, and the proposed requirement does not specifically require that passenger cars have four side doors. For instance, the requirement would be met if a passenger car had two double-wide doors that permit two 95th-percentile males to pass through each door at the same time—the functional equivalent of four side doors having openings of the specified size. FRA is interested in comments concerning the extent to which existing designs of passenger cars cannot comply with the proposed requirement, and FRA may modify the proposal based on the information supplied. As a longer term approach, FRA is investigating an emergency evacuation performance requirement similar to that used in commercial aviation where a sufficient number of emergency exits must be provided to evacuate the maximum passenger load in a specified time for various types of emergency situations.

Paragraph (b) also provides that each powered, exterior side door be equipped with a manual override feature the same as that required in paragraph (a) for existing equipment, except that the manual override must also be capable of opening the door from outside the car.

This requirement is intended to provide quick access to a passenger car by emergency response personnel, and represents the consensus recommendation of the Working Group.

FRA is also considering, but has not proposed in this rule, that for passenger cars ordered on or after January 1, 1999, or placed in service for the first time on or after January 1, 2001, the status of each powered, exterior side door shall be displayed to the crew in the operating cab of the train. Such a proposal had support from Working Group members and would enable a crewmember in the operating cab to determine whether train doors are closed before departure, for example. However, FRA is concerned that railroads operating Tier I passenger equipment would be unable to meet this requirement. Because Tier I passenger trains are not intended to operate as a fixed unit and instead passenger cars are freely switched into and out of such trains, practical concerns exist about the compatibility of door sensor equipment in a Tier I passenger train. Commenters are invited to address this issue.

To make sure that manual override devices are easily accessible by passengers, FRA is proposing requirements in paragraph (c) addressing covers and screens used to protect such devices from casual or inadvertent use. FRA desires to balance the concern that passengers may unnecessarily exit cars when no emergency is present with the need for passengers to easily access a door-release mechanism in an emergency. Although this proposal reflects general discussions within the Working Group, it is not specifically a Working Group recommendation.

Paragraph (d) is reserved for door marking and operating instruction requirements. These requirements are currently being addressed in the proposed rule on passenger train emergency preparedness. See 62 FR 8330, Feb. 24, 1997.

§ 238.239 Automated Monitoring

This section requires on or after January 1, 1998, an operational alerter or a deadman control in the controlling locomotive of each passenger train operating in other than cab signal, automatic train control, or automatic train stop territory. This section further requires that such locomotives ordered on or after January 1, 1999, or placed in service for the first time on or after January 1, 2001, must be equipped with a working alerter. As a result, the use of a deadman control alone on these new locomotives would be prohibited. The Working Group recommended that new

locomotives be equipped with a working alerter, and FRA is proposing that existing locomotives also be equipped with either a working alerter or a deadman control as provided in paragraph (a).

An alerter will initiate a penalty brake application if it does not receive the proper response from the engineer. Likewise, a deadman control will initiate a penalty brake application if the engineer fails to maintain proper contact with the device. The Working Group discussed establishing specific setting requirements for alerters or deadman controls based on maximum train speed and the capabilities of the signal system. This discussion led to the conclusion that settings should be left to the discretion of individual railroads as long as they document the basis for the settings that they select. If the device fails en route, the proposed rule requires a second person qualified on the signal system and brake application procedures to be stationed in the cab or the engineer must be in constant radio communication with a second crewmember until the train reaches the next terminal. This is intended to allow the train to complete its trip with the device's function of keeping the operator alert taken over by another member of the crew.

Alerters are safety devices intended to verify that the engineer remains capable and vigilant to accomplish the tasks that he or she must perform. Equipping passenger locomotives with an alerter is current industry practice. These devices have proven themselves in service, and the requirement will not impose an additional cost on the industry.

Subpart D—Inspection, Testing, and Maintenance Requirements of Tier I Passenger Equipment

§ 238.301 Scope

This subpart contains the proposed requirements regarding the inspection, testing, and maintenance of all types of passenger equipment operating at speeds of 125 mph or less. FRA originally considered developing one set of requirements for MU locomotives and one set for push-pull equipment. However, the Working Group determined that this approach would be redundant because nearly identical requirements could be applied to both types of equipment. Consequently, this subpart includes the proposed requirements for the inspection, testing, and maintenance of Tier I passenger equipment brake systems as well as the other mechanical and electrical safety components of Tier I passenger equipment.

§ 238.303 Exterior Calendar Day Mechanical Inspection of Passenger Cars and Unpowered Vehicles Used in Passenger Trains

This section contains the proposed requirements for an exterior calendar day mechanical inspection on passenger cars and unpowered vehicles used in passenger trains that is patterned after a combination of the current calendar day inspection required for locomotives under the Railroad Locomotive Safety Standards and the pre-departure inspection for freight cars under the Railroad Freight Car Safety Standards. See 49 CFR 229.21 and 215.13, respectively. FRA proposes that the calendar day mechanical inspection apply to all passenger cars and all unpowered vehicles used in passenger trains (which includes, e.g., not only coaches, MU locomotives, and cab cars but also any other unit of rail rolling equipment used in a passenger train). A mechanical safety inspection of freight cars has been a longstanding Federal safety requirement, and FRA believes that the lack of a similar requirement for passenger equipment creates a serious void in the current Federal railroad safety standards.

Paragraphs (a) and (b). Rail labor representatives advocate a daily inspection of all safety-related mechanical components with pass/fail criteria or limits written into the Federal safety standards much like the requirements contained in 49 CFR part 215, whereas, APTA and other passenger railroad representatives strongly maintain that specific inspection criteria or limits are not necessary. During the ongoing meeting of the Working Group, FRA repeatedly requested that railroad representatives provide a recommended list of mechanical components and criteria for their inspection. These representatives consistently responded with very broad requirements basically limited to inspections for obvious and visible defects. Although passenger railroad representatives do not object to the safety principle of a mechanical inspection, they do not want their operations to be bound by a rigid list of components and criteria for the inspection.

FRA agrees with labor representatives that a specific list of components to be inspected with enforceable inspection or pass/fail criteria needs to be included as part of the proposed Passenger Equipment Safety Standards. For several years, Amtrak has been conducting voluntary mechanical safety inspections of passenger train components. Amtrak, working in conjunction with FRA, has

developed a list of components to be inspected and "go" "no go" inspection criteria for the various components. Amtrak has trained mechanical employees to conduct these inspections and has issued pocket guides containing the inspection criteria to all mechanical employees. FRA commends Amtrak for its progressive and voluntary efforts. Furthermore, based upon investigations conducted by FRA field inspectors, it appears that virtually every passenger railroad currently performs some type of daily mechanical inspection on its passenger equipment. Consequently, FRA proposes to codify various requirements and minimum standards for conducting a calendar day mechanical inspection.

Paragraph (a) requires that each passenger car and each unpowered vehicle used in a passenger train receive an exterior mechanical safety inspection at least once each calendar day that the equipment is placed in service except under the circumstances described in paragraph (d). Paragraph (b) requires that this inspection be performed by a qualified mechanical inspector. FRA believes the combination of a daily Class I brake test and a mechanical safety inspection performed by fully qualified mechanical employees is a key to safer passenger railroad operations. Such a practice will most likely detect and correct equipment problems before they become the source of an accident or incident resulting in personal injuries or damage to property. FRA recognizes that this requirement may create a problem for some commuter railroads that operate trains on weekends or other days when qualified mechanical inspectors are not scheduled to work. Some railroads may be forced to schedule qualified mechanical inspectors to work on these days at additional expense. However, based on independent investigations performed by FRA, it is believed that the impact of this proposal will be much less than several railroad representatives have indicated. Nevertheless, FRA is willing to consider whether to allow railroads that have demonstrated an ability to operate passenger trains safely over weekends without a mechanical safety inspection being performed by qualified mechanical inspectors to continue that practice. The problem, from FRA's position, is that it is difficult to allow this flexibility without creating a loophole that could be abused in certain circumstances. Consequently, FRA solicits detailed comments from interested parties on whether the granting of such flexibility is even

necessary and on possible methods for providing such flexibility.

Paragraph (c) identifies the components that FRA proposes to be inspected as part of the exterior daily mechanical safety inspection and provides measurable inspection criteria for the components. The railroad is required to ascertain that each passenger car, and each unpowered vehicle used in a passenger train conforms with the conditions enumerated in paragraph (c). Deviation from any listed condition makes the passenger car or unpowered vehicle defective if it is in service. The Working Group members generally agreed that the components contained in this section represent valid safety-related components that should be frequently inspected by railroads. However, members of the Working Group had widely different opinions regarding the criteria to be used to inspect these components. Therefore, as FRA was not provided any clear guidance from the Working Group, FRA selected inspection criteria based on the locomotive calendar day inspection and the freight car safety pre-departure inspection required by 49 CFR parts 229 and 215, respectively. FRA believes that, at a minimum, passenger cars should receive an inspection which is at least equivalent to that received by locomotives and freight cars. FRA solicits comments from interested parties concerning other sets of mechanical safety inspection criteria. For example, a concern has been raised by some parties regarding the securement of doors on baggage cars. Consequently, FRA seeks comments from interested parties on the necessity to inspect these doors as part of any required daily mechanical inspection.

APTA believes that this section contains exterior inspection requirements that cannot be safely or practically performed in the field. In particular, APTA maintains that the inspections concerning the draft gear, truck attachment, suspension system, and coupler knuckle can only be properly performed by placing each car individually over a repair pit.

FRA intends for the daily mechanical inspection to serve as the time when the railroad repairs defects that occurred en route. Thus, this section proposes to require that safety components not in compliance with this part be repaired before the equipment is permitted to remain in or return to passenger service. (See § 238.9 for a discussion of the prohibitions against using passenger equipment containing defects; and §§ 238.15 and 238.17 for a discussion of movement of defective equipment for purposes of repair or sale). The purpose

of the defect reporting and tracking system proposed in § 238.19 is to have the mechanical forces make all necessary safety repairs to the equipment before it is cleared for another day of operation. In other words, FRA intends for the flexibility to operate defective equipment in passenger service to end at the calendar day mechanical inspection.

The narrow exception in paragraph (d) allows long-distance intercity passenger trains that miss a scheduled exterior calendar day mechanical inspection due to a delay en route to continue in passenger service to the location where the inspection was scheduled to be performed. At that point, a calendar day mechanical inspection must be performed prior to returning the equipment to service of any kind. This flexibility applies only to the mechanical safety inspections of coaches. FRA does not intend to relieve the railroad of the responsibility to perform a locomotive calendar day inspection as required by 49 CFR part 229.

Paragraph (e) specifies an additional contingent component of the calendar day exterior mechanical inspection. If a car requiring a single car test is moved in a train carrying passengers or available to carry such passengers to a place where the test can be performed, then the single car test must be performed before or during the exterior calendar day mechanical inspection.

§§ 238.305 and 238.307 Interior Calendar Day Mechanical Inspection and Periodic Mechanical Inspection of Passenger Cars

Section 238.305 requires the performance of an interior inspection of passenger cars (which includes, e.g., passenger coaches, MU locomotives, and cab cars) each calendar day that the equipment is used in service except under the circumstances described in paragraph (d). Unlike the exterior calendar day mechanical inspection, FRA proposes in § 238.305(b) to permit the interior inspections of passenger cars to be performed by "qualified persons," individuals qualified by the railroad to do so. Thus, these individuals need not meet the definition of a "qualified mechanical inspector."

FRA's original position was to require the interior inspections to be performed by qualified mechanical inspectors. However, after several discussions with members of the Working Group and several other representatives of passenger railroads, FRA determined that the training and experience typical of qualified mechanical inspectors is not necessary and often does not apply to

inspecting interior safety components of passenger equipment. In addition, the flexibility created by permitting someone less qualified than a mechanical inspector can reduce the cost of performing the mechanical safety inspection since the most economical way to accomplish the mechanical inspection is to combine the exterior inspection with the Class I brake test and then have a crewmember or train coach cleaner combine the interior coach inspection with coach cleaning.

Section 238.305(c) lists various components that FRA proposes to be inspected as part of the interior daily mechanical safety inspection. As a minimum, FRA proposes that the following components be inspected: trap doors; end and side doors; manual door releases; safety covers, doors and plates; vestibule step lighting; and safety-related signs and instructions. Consistent with the proposed exterior inspection requirements, FRA proposes that all en route defects and all noncomplying conditions must be repaired at the time of the daily interior inspection in order for the equipment to be placed or remain in passenger service with the exception of a defect under § 238.305(c)(5). (See § 238.9 for a discussion of the prohibitions against using passenger equipment containing defects, and § 238.17 for a discussion of the movement of defective equipment for purposes of repair.) Furthermore, § 238.305(d) allows long-distance intercity passenger trains that miss a scheduled calendar day mechanical inspection due to a delay en route to continue in passenger service to the location where the inspection was scheduled.

Initially, FRA considered requiring a more extensive list of components to be checked at each daily interior inspection. However, based on discussions conducted with the Working Group, FRA determined that the daily inspection and repair of some interior items could be burdensome to the railroads without producing an offsetting safety benefit. As a result, FRA in § 238.307 proposes a periodic mechanical inspection for passenger cars (which include, e.g., passenger coaches, MU locomotives, and cab cars) in order to reduce the frequency with which certain components require inspection and repair. FRA proposes to require that the following components be inspected for proper operation and repaired, if necessary, as part of the periodic maintenance of the equipment: emergency lights; emergency exit windows; seats and seat attachments; overhead luggage racks and

attachments; floor and stair surfaces; and hand-operated electrical switches.

Virtually all passenger railroads currently have defined periodic maintenance intervals for all of the equipment they operate. These intervals vary depending on the type of equipment and the service in which it is used, but typically range from 60 to 180 days. Although FRA does not intend to limit the railroad's flexibility to set periodic maintenance intervals, FRA believes that an outside limit must be placed on the performance of the periodic mechanical inspection. Thus, FRA proposes that the periodic mechanical inspection be performed at least every 180 days, as that appears to be the outside limit of currently established maintenance cycles. As with the daily inspection, any known defects or conditions not in compliance with this section which are uncovered by the periodic inspection must be repaired in order for the equipment to remain in or return to passenger service.

APTA has advised FRA that most of the daily interior inspection requirements proposed in this section are currently performed as part of a railroad's own periodic inspection. Moreover, APTA maintains that the daily interior inspection requirements do not add to safety and will create delays impacting on-time performance. APTA believes that many cars with defects found during both the daily interior and exterior inspections can be operated safely with appropriate restrictions without first shopping the cars. Commenters are asked to address the various concerns raised by APTA.

§ 238.309 Periodic Brake Equipment Maintenance

This section contains the proposed requirements for the performance of periodic brake maintenance for various types of passenger equipment, referred to in the industry as clean, oil, test, and stencil (COT&S).

Paragraph (b) extends the periodic maintenance interval for MU locomotive fleets that are 100 percent equipped with air dryers and modern brake systems from 736 days to 1,104 days. The requirement remains 736 days for fleets that are not 100 percent equipped with air dryers or that are equipped with older brake systems. FRA bases this proposed extension on tests conducted by Metro-North and monitored by FRA field inspectors. These tests revealed that after three years, brake valves on MU locomotives equipped with air dryers were very clean and showed little or no signs of deterioration. Based on the results of these tests, FRA is confident that these

valves can safely operate for three years between periodic maintenance. FRA believes this extension of the periodic maintenance interval will result in a cost savings to those railroads that operate MU locomotives equipped with air dryers.

Paragraph (c) extends the periodic maintenance interval on conventional locomotives equipped with 26-L or equivalent types of brakes from the current standard of 736 days to 1,104 days. The required periodic maintenance interval remains at 736 days for locomotives equipped with other types of brake systems. The proposed requirement merely makes universal a practice that has been approved by waiver for several years. See H-80-7. FRA believes that locomotives equipped with 26-L brakes have demonstrated an ability to operate safely for three years between periodic maintenance.

Paragraph (d) extends the periodic maintenance interval on passenger coaches and other unpowered vehicles equipped with 26-C or equivalent brake systems from 1,104 days to 1,476 days. This extension is based on tests performed by Amtrak. Based on these tests, FRA granted Amtrak a waiver for this extension on July 26, 1995. See FRA Docket No. PB 94-3. Amtrak has operated under the terms of this waiver for several years with no problems. Consequently, based on Amtrak's experience, FRA believes all passenger cars with 26-C equipment can safely be operated for four years between periodic maintenance.

Paragraph (e) proposes that the same extensions applicable to locomotives and passenger coaches should be applied to control cab cars that use brake valves that are identical to the 26-C valves used in passenger cars or the 26-L valves used on locomotives. Consequently, based on the information and tests conducted on those valves as well as waivers currently existing, FRA proposes to extend the periodic maintenance interval for cab cars to 1,476 days or 1,104 days for those cab cars that use brake systems identical to the 26-C and 26-L, respectively. This proposed extension is consistent with recent requests for waivers received by FRA.

A railroad may petition FRA, under § 238.21, to approve alternative maintenance procedures providing equivalent safety. Railroads could propose using periodically scheduled single car tests to extend the time between required periodic maintenance on passenger coaches. FRA believes that the single car test provides a good alternative to more frequent periodic

maintenance. In fact, in the previous NPRM on power brakes, FRA proposed the elimination of time-based COT&S and in its stead proposed time intervals for conducting single car tests, ranging from three to six months, depending on the utilization rate of the passenger equipment. See 59 FR 47690-47691, 47710-47711, and 47740-47741. However, comments received and discussions with members of the Working Group revealed that many passenger railroads would rather perform periodic maintenance than more frequent single car tests. One reason for this is that some operators would rather take equipment out of service every few years and perform the overhaul of the brake system rather than having equipment out of service for shorter periods every few months. Therefore, FRA proposes to retain periodic maintenance intervals but provide the alternative to railroads to propose single car testing intervals in order to reduce the frequency with which the periodic maintenance is performed. Consequently, railroads are afforded some flexibility to determine the type of maintenance approach that best suits their operations.

§ 238.311 Single Car Test

This section contains the proposed requirements for single car tests of passenger equipment. Although the Working Group failed to reach consensus on the requirements contained in this section, the group did agree that single car tests are a valuable tool to demonstrate that a car's brake system performs correctly after repairs have been made that could affect the brakes. A major issue raised both in comments to the previous NPRM on power brakes and by various members of the Working Group was the method for specifying how the test is to be performed. Labor representatives objected to specifying the method of testing by reference to an industry standard that could be changed unilaterally by the organization that maintains the standard. These representatives insisted that the requirements specifying how to conduct the test must be contained in the rule text so that the only way that changes can be made is through the administrative procedures required by the formal rulemaking process. FRA agrees and proposes in paragraph (a) to require that passenger railroads perform the single car test of the brake system in accordance with AAR Standard S-044 contained in AAR's "Instruction Pamphlet 5039-4, Supp. 3 (April 1991)," which is the most recent version of the test description. FRA also

proposes that the special approval process detailed in § 238.21 would be employed to evaluate any proposed changes in this highly technical procedure.

The single car test proposed in this section has proven effective in uncovering brake system problems that are the root cause of certain wheel defects or that have been caused by repairs made to the brake system. FRA believes that this test has contributed to the current trend of greater brake system reliability and fewer brake-related accidents/incidents of passenger equipment. Currently, the regulations require that a single car test be performed on passenger cars whenever they are on a shop or repair track. In the previous NPRM on power brakes, FRA discussed the potential loophole that the current regulations permit. See 59 FR 47710. Basically, it has the potential of allowing railroads to avoid the performance of the tests by calling repair tracks something other than a repair track. Although this is an issue that has arisen in the freight context, it does appear prudent to base the requirement to perform a single car test on the type of defect involved rather than the location where the defect is repaired.

Paragraph (b) lists the wheel defects that would trigger the requirement to perform a single car test. FRA believes that the proposed wheel defects indicate some type of braking equipment problem. FRA believes that merely changing a wheel to correct a wheel defect that is actually caused by a brake system problem will only lead to a continuation of the problem on the new wheel and will increase repair costs to the railroad. A test that checks for the root cause of the defect is not only a good safety practice, but is a good business practice that will lead to reduced operating costs.

Paragraph (c) requires a railroad to conduct a single car test if one or more of the identified brake system components is removed, repaired, or replaced. This paragraph also proposes that a single car test be performed if a passenger car or vehicle is placed in service after having been out of service for 30 or more days. FRA believes that these requirements will ensure that brake system repairs have been performed correctly and that the car's brake system will operate as intended after repairs are made or after the car has been in storage for extended periods. The proposed requirements are consistent with the current practices of most passenger railroads.

Paragraph (d) requires that all single car tests be performed by qualified

mechanical inspectors. A single car test is a comprehensive brake test that requires the skills and knowledge of a professional mechanical employee. Railroads currently use the "qualified mechanical inspector" as defined by this part to perform single car tests, and FRA believes that this practice should continue.

Paragraph (e) provides that if a single car test cannot be made at the point where repairs are made, the car may be moved in service to the next forward location where the test can be made. The single car test shall be completed prior to, or as a part of, the car's next calendar day mechanical inspection.

APTA has advised FRA that the proposed section on single car tests contains an outdated standard and requires a large number of tests which do not serve to enhance safety. APTA believes that actual operating experience does not support a requirement for this level of testing, and the proposal will increase maintenance costs and require additional spare vehicles to maintain service. Additionally, APTA maintains that the proposed regulation provides a disincentive to updating single car test procedures as needed.

§ 238.313 Class I Brake Test

This section contains the proposed requirements related to Class I brake tests. FRA proposes that the requirements in this section apply to all passenger coaches, control cab cars, MU locomotives, and all nonself-propelled vehicles that are part of a passenger train. The Working Group was unable to reach consensus on the requirements proposed in this section.

This section proposes to require that a Class I brake test be performed at least once each calendar day that a piece of equipment is placed in service. As discussed previously, the Working Group discussed and debated when and how a Class I brake test should be performed. Labor representatives stressed the need for a thorough brake test performed by qualified mechanical inspectors on every passenger train. These representatives strongly contended that this brake test must be performed prior to the first daily departure of each passenger train. On the other hand, representatives of passenger railroads expressed the desire to have flexibility in conducting a comprehensive brake inspection, arguing that safety would be better served if railroads were permitted to conduct these inspections on a daily basis.

Although FRA agrees with the position advanced by many labor

representatives that some sort of car-to-car inspection must be made of the brake equipment prior to the first run of the day, FRA does not agree that it is necessary to perform a full Class I brake test in order to ensure the proper functioning of the brake equipment. As FRA proposes that a Class I brake test consist of a comprehensive inspection of the braking system, including the proper operation of supplemental braking systems, FRA believes that commuter and short-distance intercity passenger train operations must be permitted some flexibility in conducting these inspections. Consequently, FRA proposes in paragraph (a) to require that commuter and short-distance intercity passenger train operations perform a Class I brake test sometime during the calendar day in which the equipment is used.

However, FRA also recognizes the differences between commuter or short-distance intercity operations and long-distance intercity passenger train operations. Long-distance intercity passenger trains do not operate in shorter turnaround service over the same sections of track on a daily basis for the purpose of transporting passengers from major centers of employment. Instead, these trains tend to operate for extended periods of time, over long distances with greater distances between passenger stations and terminals. Further, these trains may operate well over 1,000 miles in any 24-hour period, somewhat diminishing the opportunity for conducting inspections on these trains. Therefore, FRA believes that a thorough inspection of the braking system on these types of operations must be conducted prior to the trains' departure from an initial starting terminal. Consequently, FRA proposes in paragraph (b) that a Class I brake inspection be performed on long-distance intercity passenger trains prior to departure from an initial terminal. FRA does not believe there would be any significant burden placed on these operations as the current regulations require that an initial terminal inspection be performed at these locations. Furthermore, virtually all of the initial terminal inspections currently conducted on these types of trains are performed by individuals who would be considered qualified mechanical employees under this proposal.

FRA also recognizes that these long-distance intercity passenger trains could conceivably travel over 3,000 miles if Class I inspections were required only once every 24 hours that the equipment is in service, as proposed for commuter and short-distance intercity passenger

trains. Thus, FRA believes that some outside mileage limit must be placed on these trains between brake inspections. Currently, a passenger train can lawfully travel no further than 1,000 miles from its initial terminal, at which point it must receive an intermediate inspection of brakes, which includes application of the brakes to ensure brake pipe continuity and the inspection of the brake rigging to ensure it is properly secured. See 49 CFR 232.12(b). However, in recognition of the improved technology used in passenger train brake systems, combined with the comprehensive nature of the proposed Class I brake tests and mechanical safety inspections both being performed by qualified mechanical inspectors, FRA proposes to require that the proposed Class I brake test be performed once every calendar day that the equipment is used or every 1,500 miles, whichever occurs first.

Paragraph (c) requires that the Class I brake tests be performed by qualified mechanical inspectors. As FRA intends for these Class I brake inspections to be in-depth inspections of the entire braking system, which most likely will be performed only one time in any given day in which the equipment is used, FRA believes that these inspections must be performed by individuals possessing the knowledge to not only identify and detect a defective condition in all of the brake equipment required to be inspected but also the knowledge to recognize the interrelational workings of the equipment and the ability to trouble-shoot and repair the equipment. Furthermore, most passenger railroads currently have a daily brake test performed by mechanical employees so this requirement is not really a departure from current industry practice.

FRA recognizes that these requirements may create a problem for some commuter railroads that operate trains on weekends or other days when qualified mechanical inspectors are not scheduled to work. Some railroads may be forced to schedule qualified mechanical inspectors to work on these days at additional expense. However, based on independent investigations performed by FRA, it is believed that the impact of this proposal will be much less than several railroad representatives have indicated. However, FRA is willing to consider whether to allow railroads that have demonstrated an ability to operate passenger trains safely over weekends without a mechanical safety inspection being performed by qualified mechanical inspectors to continue that practice. The problem, from FRA's position, is that it is difficult to allow

this flexibility without creating a loophole that could be abused in certain circumstances. Consequently, FRA solicits detailed comments from interested parties on whether the granting of such flexibility is even necessary and on possible methods of providing such flexibility.

Paragraph (d) provides railroads with the option to perform the Class I brake test either separately or in conjunction with the calendar day mechanical inspections. FRA proposes this provision simply to clarify that the two inspections need not be done at the same time or location as long as they are both performed sometime during the day.

Paragraph (e) prohibits a railroad from using or hauling a passenger train in passenger service from a location where a Class I brake test has been performed, or was required to have been performed, with less than 100 percent operating brakes. (See § 238.15 for a discussion of movement of defective equipment for purposes of repair or sale).

Paragraph (f) contains a proposed list of the safety-related items that must be inspected, tested, or demonstrated as part of a Class I brake test. This list was developed based on the experience and knowledge of FRA's motive power and equipment field inspectors familiar with the operations and inspection practices of passenger operations. The Working Group extensively discussed the items contained in this proposal. Paragraph (f)(1) requires that an inspection be conducted on each side of each car to verify the application and release of each brake. This requirement is consistent with FRA's longstanding interpretation of what the current regulations require when conducting initial terminal and 1,000 brake inspections pursuant to § 232.12. For clarity and consistency, FRA has explicitly incorporated the requirement into this proposal.

The requirements included in paragraph (f) which FRA proposes to be included in a Class I brake test contain two items that would bar the use of a train that current regulations allow to be placed in service. These include the requirement that the secondary brake systems must be fully operational and the requirement that brake indicators must function as intended. These requirements will require railroads to make more frequent repairs than are currently required. However, FRA believes these added costs are necessitated by and offset by the added flexibility to move defective equipment as well as the ability to use brake indicators during the performance of

certain brake tests in lieu of direct observation of the brakes.

Paragraph (g) proposes to require the qualified mechanical inspector that performs a Class I brake test to record the date, time and location of the test as well as the number of the controlling locomotive of the train. This minimal information would be required to be available in the cab of the controlling locomotive to demonstrate to the train crew and future inspectors that the train is operating under a current Class I brake test. Furthermore, the use of such records or "brake slips" as they are known in the industry is the current practice of virtually all passenger railroads. FRA believes that this recordkeeping requirement adds necessary reliability, accountability, and enforceability to the inspection requirements proposed in this section.

Paragraph (h) also proposes to allow long distance, intercity passenger trains that miss a scheduled Class I brake test due to a delay en route to proceed to the point where the scheduled brake test was to be performed. This flexibility prevents Amtrak or other operators of long distance trains from having to dispatch qualified mechanical inspectors to the location of a delayed train merely to meet the calendar day Class I brake test requirement. This is a common sense exception that will not compromise safety.

§ 238.315 Class IA Brake Test

This section contains the proposed requirements regarding Class IA brake tests. As mentioned previously, although FRA agrees with the position advanced by many labor representatives that some sort of car-to-car inspection must be made of the brake equipment prior to the first run of the day, FRA does not agree that it is necessary to perform a full Class I brake test in order to ensure the proper functioning of the brake equipment in all situations. However, contrary to the position espoused by several railroad representatives, FRA believes that something more than just a determination that the brakes on the rear car set and release is necessary.

Currently, the quality of initial terminal tests performed by train crews is likely adequate to determine that brakes apply on each car. However, most commuter equipment utilizes "tread brake units" in lieu of cylinders and brake rigging of the kind prevalent on freight and some intercity passenger cars. It is undoubtedly the case that train crewmembers do not verify application of the brakes by tapping brake shoes while the brakes are applied, the only effective means of

determining that adequate force is being applied. This is one reason why the subject railroads typically conduct redundant initial terminal tests at other times during the day. Further, train crews are not asked to inspect for wheel defects and other unsafe conditions, nor should they be asked to do so, given the conditions under which they are asked to inspect and the training they receive.

Consequently, paragraph (a) requires that, at a minimum, a Class I or Class IA brake test be performed prior to a commuter or short-distance intercity passenger train's first departure on any given day. FRA believes that the proposed Class IA brake test is sufficiently detailed to ensure the proper functioning of the brake system, yet not so intensive that it requires individuals to perform an inspection for which they are not qualified. FRA proposes in paragraph (a) that a qualified mechanical inspector or a properly trained and qualified train crewmember perform a Class IA brake test.

As noted in the discussion of Class I brake tests, FRA recognizes the differences between commuter or short-distance intercity operations and long-distance intercity passenger train operations. FRA believes that a thorough inspection of the braking system on these types of operations must be conducted prior to each train's departure from an initial starting terminal. Consequently, FRA will not permit the use of Class IA brake tests for these trains, and requires that a Class I brake inspection be performed on long-distance intercity passenger trains prior to departure from an initial terminal.

Paragraph (a) also requires that a Class IA brake test be performed prior to placing a train in service if that train has been off a source of compressed air for more than four hours. This requirement formalizes a long-standing agency interpretation of the existing power brake regulations but increases the time limit from two hours to four hours. Labor representatives maintain that any number of brake system problems can develop with equipment off air for only a short time, while management representatives contend that equipment can be left off air for extended periods of time with no problems. FRA believes the proposed requirement is a fair compromise that allows railroads some operating flexibility, but does not allow equipment to be off air without a new brake test for extended periods of time. As stated in the previous NPRM on power brakes, FRA agrees that its longstanding administrative interpretation of allowing cars to be "off air" for only two hours was established

prior to the development of new equipment that has greatly reduced leakage problems. However, contrary to the contentions of some commenters, FRA does not believe that cars should be allowed to be "off air" for extended periods without being retested. The longer cars sit without a supply of compressed air attached, the greater the chances are that the integrity of the system will be compromised, either by weather conditions or vandalism.

Paragraph (b) allows a commuter or short-distance intercity passenger train that provides continuing late night service that began prior to midnight to complete its daily operating cycle after midnight without performing another Class I or Class IA brake test.

Paragraph (c) allows a Class IA brake test to be performed at a shop or yard site without needing the test repeated at the first passenger terminal if the train remains on air and in the custody of the crew. This provision is an incentive for railroads to conduct the tests at locations where they can be performed more safely and easily. FRA believes that a shop or yard location is more conducive for conducting a proper brake test. Raised platforms and other conditions frequently found at terminals can make the performance of a brake test difficult, if not hazardous.

Paragraph (d) permits the Class IA test to be performed by either a qualified person or a qualified mechanical inspector. Paragraph (e) prohibits a railroad from using or hauling a passenger train from a location where a Class IA brake test has been performed, or was required to have been performed, with less than 100 percent operative brakes. (See §§ 238.15-238.17 for a discussion of movement of defective equipment for purposes of repair or sale). Paragraph (f) establishes the requirements for conducting a proper Class IA brake test. It is proposed that a Class IA brake test include: a check that each brake sets and releases, a test of the emergency brake application feature, a check of the deadman or other emergency control device, a check that piston travel is in the nominal range for the type of brake equipment, and an observation that angle cocks and cutout cocks are properly set and that brake pipe pressure changes are communicated to the rear of the train.

Paragraph (g) requires that the inspection of the set and release of the brakes be performed by walking the train so the inspector actually observes the set and release of each brake. Labor representatives strongly contended that this is the only way to do a proper brake test. They believe that observation of brake indicators does not give a reliable

indication of effective brakes because the indicators sense brake cylinder pressure rather than the force of the brake shoe against the wheel or the pad against the disc. However, this section proposes to allow an exception when railroads determine that direct observation of the set and release can place the inspector in danger. FRA acknowledges the contention of rail management representatives that conditions at certain locations where Class IA tests may be performed could place the inspector in danger if he or she is required to place himself or herself in a position to actually observe the set and release of each brake. Where railroads determine this to be the case, FRA will permit the use of brake indicators for the set and release step of the Class IA brake test as long as the inspector takes a position where an accurate observation of the indicators can be made.

§ 238.317 Class II Brake Test

This section proposes the requirements regarding how a Class II brake test is to be performed and contains the proposed conditions for when a railroad is required to perform the brake test. The Class II brake test provides passenger railroads the flexibility to continue to use train crew personnel to perform the limited brake tests required when minor changes to the train occur. Both labor and management representatives to the Working Group recognized that train crews are capable of performing the relatively simple checks required by a Class II brake test and that the operations of most commuter and passenger railroads require the flexibility of having operating personnel perform these tests.

Paragraph (c) requires that passenger trains not depart from Class II brake tests which are performed at a terminal or a yard with any brakes known to be cut-out, inoperative, or defective. This requirement was agreed to by members of the Working Group and is consistent with the movement for repair provisions contained in this proposal. See § 238.15. Terminals and yards are generally the best locations available to a railroad for either conducting repairs or removing a vehicle from a train. This requirement only applies to brake equipment which is known to be cut-out, inoperative, or otherwise defective by the railroad prior to the train's departure from the yard or terminal where the Class II brake test is performed.

Paragraph (d) requires that a Class II brake test consist of: a check that the brakes on rear unit of the train apply and release in response to brake control

signals, a test of the emergency brake application, a test of the deadman pedal or other emergency control device, and a check that brake pipe pressure changes are properly communicated at the rear of the train. FRA believes that if the equipment receives a full Class I brake test and a calendar day mechanical inspection at some time during each operating day, then these simple checks are adequate to confirm brake system performance at intermediate terminals or turning points. This requirement basically codifies current industry practice.

§ 238.319 Running Brake Tests

This section contains the proposed requirements for conducting running brake tests on the brakes of passenger trains. A running brake test is merely a brake application at the first safe opportunity to confirm that the brake system works as expected by the engineer. FRA proposes that a running brake test be performed in accordance with the railroad's established operating rules after the train has received a Class I, Class IA, or Class II brake test as safety permits. FRA believes that railroads are in the best position to determine when and where running tests can be safely performed. As most passenger railroads routinely conduct running brake tests, FRA believes that the proposal requirement captures an important safety check without changing current operating practice to any great extent.

Tier II Passenger Equipment Requirements

Most of the requirements proposed for Tier II equipment are based on lengthy discussions between Amtrak and FRA over safety requirements for operation of passenger train sets at speeds up to 150 mph in the Northeast Corridor (NEC). Amtrak voluntarily included many of the provisions proposed for Tier II equipment in their procurement specification for American Flyer trainsets—the first Tier II equipment which should be placed in regular revenue service in the United States.

The process used by the Working Group to discuss proposed Tier II equipment standards differed from that used for the Tier I standards. Many members of the full Working Group stated that they will never be involved in the operation of such high-speed equipment and participation in Tier II standards was outside their area of interest and expertise. As a result, the full Working Group recommended the formation of a smaller subgroup to consider Tier II standards. Consequently, a subgroup consisting of representatives from Amtrak, equipment

builders, labor organizations, the NTSB and FRA was formed to consider Tier II equipment safety standards.

The Tier II Equipment Subgroup came very close to reaching full consensus recommendations on the proposed Tier II safety standards. Only two exceptions to a full consensus on recommendations resulted from the process. The first exception involves a disagreement between Amtrak and labor organizations over the proper use of brake indicator technology.

The second exception results from a joint meeting between the Tier II equipment subgroup and the RSAC High Speed Track Standards Working Group. The purpose of this joint meeting was to ensure that the two sets of proposed standards not conflict at the wheel-rail interface where the two sets of standards overlap.

These two exceptions to full consensus will be more fully discussed under the appropriate section of this section-by-section analysis. In all other cases, the section-by-section analysis assumes the full consensus of the Subgroup without actually repeating it as part of each of the discussions.

Subpart E—Specific Requirements for Tier II Passenger Equipment

§ 238.401 Scope

This subpart contains the design and performance requirements for Tier II passenger equipment operating at speeds exceeding 125 mph but not exceeding 150 mph. Unless otherwise specified, the proposed requirements represent the consensus recommendations of the Tier II Equipment Subgroup with refinements by FRA for clarity, enforceability, and compatibility with other rail safety laws. For the most part, compliance with the requirements of this section will be demonstrated by one-time analysis or initial acceptance tests.

The requirements contained in this subpart have their basis in discussions between Amtrak and FRA involving safety requirements for the operation of passenger trainsets at speeds up to 150 mph on the Northeast Corridor (NEC). Aware that FRA was considering the development of safety standards for high-speed passenger rail equipment, Amtrak asked FRA for assistance in developing a set of safety specifications for the procurement of high-speed trainsets which would address FRA's safety concerns. As a result, Amtrak's American Flyer trainsets, scheduled to begin regular passenger service in 1999, will very likely comply with all of the proposed safety standards in this subpart.

Amtrak's discussions with FRA led it to sponsor a risk assessment of high speed rail passenger systems on the north end of the NEC—from New York to Boston. The discussions also prompted FRA to sponsor computer modeling to predict the performance of various equipment structural designs and configurations in collisions. A copy of the risk assessment performed by Arthur D. Little, Inc., for Amtrak is included in the docket of this rulemaking. The risk assessment was based on existing and predicted future right-of-way configurations and traffic density patterns. The risk assessment concluded that a significant risk of collisions at speeds below 20 mph and a risk of collisions at speeds exceeding 100 mph exist over the 20-year projected operational life of the American Flyer trainsets—due to heavy and increasing conventional commuter rail traffic, freight rail traffic on the NEC, highway-rail grade crossings, moveable bridges, and a history of low speed collisions in or near stations and rail yards.

Based on the risk assessment and the results of the computer modeling, Amtrak and FRA determined that reliance on collision avoidance measures rather than crashworthiness, though the hallmark of safe high-speed rail operations in several parts of the world, could not be implemented in corridors like the north end of the NEC. Existing traffic and right-of-way configurations do not permit implementation of the same collision avoidance measures that have proven successful in Europe and Japan. To compensate for the increased risk of a collision, a more crashworthy trainset design is needed. As a result, the set of structural design requirements proposed for Tier II passenger equipment is more stringent than current design practice for North American passenger equipment or for high-speed rail equipment in other parts of the world.

§ 238.403 Crash Energy Management Requirements

This section requires that each power car and trailer car be designed with a crash energy management system to dissipate kinetic energy during a collision. This section should be read with the discussion of crash energy management in the preamble.

During discussions with Amtrak over the safety provisions for the American Flyer trainsets, FRA proposed very challenging crash energy management requirements based on predictions using computer modeling. Amtrak believed that meeting these requirements would be well beyond the current state of the

art for passenger equipment design, and that an extensive and costly research and testing program would be required. As an alternative, Amtrak proposed a crash energy management design based on the demonstrated, commercially viable design developed by France and incorporated in the most recent design of the TGV trainset. FRA believes that Federal safety standards must be capable of implementation in the design of passenger equipment without driving the cost of implementation to the point that high speed rail systems are no longer financially viable.

As a result, paragraph (c) proposes a crash energy management system capable of absorbing a minimum of 13 megajoules (MJ) of energy at each end of the trainset. The ability to absorb this energy must be partitioned as follows: a minimum of 5 MJ by the front end of the power car ahead of the operator's control compartment; a minimum of 3 MJ by the power car structure behind the operator's control compartment; and a minimum of 5 MJ by the unoccupied end of the first trailer car adjacent to the power car. This requirement can be met using existing technology. However, it will effectively prevent a conventional cab car from operating as the lead vehicle in a Tier II passenger train because such equipment cannot absorb 5 MJ of collision energy ahead of the train operator's position. Recent accidents involving trains operating with a cab car forward have demonstrated the vulnerability of this type of equipment in collisions. FRA believes such equipment should not be used in the forward position of a train that travels at speeds greater than 125 mph. Further, FRA is specifically proposing in paragraph (f) that passenger seating be prohibited in the leading unit of a Tier II train, though not a specific recommendation of the Subgroup.

Paragraph (e) proposes the analysis process to demonstrate that equipment meets the crash energy management design performance requirements. The process allows simplifying assumptions to be made so computer modeling techniques can be used to confirm compliance.

§ 238.405 Longitudinal Static Compressive Strength

This section contains the proposed requirements for longitudinal compressive strength of power cars and trailer cars. Paragraph (a) requires the ultimate compressive strength of the underframe of the power car cab to be a minimum of 2,100,000 pounds. To form an effective crash refuge, this strength is needed to take advantage of

the strength of the power car's two end frames. Alternate design approaches that provide equivalent protection are allowed, but the equivalent protection must be demonstrated through analysis and testing and approved by the FRA Associate Administrator for Safety under the provisions of § 238.21.

Paragraph (b) contains the requirements for the static compressive strength of the occupied volumes of trailer cars. This proposal adopts the traditional North American design practice of a static strength of 800,000 pounds, without deformation of the underframe. Paragraph (c) makes clear that unoccupied or lightly occupied volumes of power cars or trailer cars may have a static end strength of less than 800,000 pounds to accommodate crash energy management designs.

The crash energy management design requirement ensures that the stronger end structures and the stronger static compressive strength of the cab of a power car will not make Tier II passenger equipment incompatible with existing passenger equipment should a collision between the two different types of equipment occur. The crash energy management design makes a Tier II passenger train appear as a softer collision surface to a conventionally designed train owing to the collision energy absorbed by the Tier II train as its unoccupied volumes intentionally crush.

§ 238.407 Anti-Climbing Mechanism

This section contains the proposed requirements for anti-climbing mechanisms on power and trailer cars. Paragraph (a) requires a power car to have a forward anti-climbing mechanism capable of resisting an upward or downward static vertical force of 200,000 pounds. This proposal is identical to that required of locomotives by AAR S-580. However, designs are permitted that require the crash energy management controlled crushing to occur prior to the anti-climber fully engaging.

Paragraph (b) requires that interior train coupling points between units, including between units of articulated cars or other permanently joined units of cars, have an anti-climbing device capable of resisting an upward or downward vertical force of 100,000 pounds. This is consistent with current design practice. Paragraph (c) requires the forward coupler of a power car to resist a vertical downward force of 100,000 pounds for any horizontal position of the coupler without yielding, and is virtually identical to that provided in 49 CFR 229.141(a) for MU locomotives built new after April 1,

1956, and operated in trains having a total empty weight of 600,000 pounds or more.

§ 238.409 Forward End Structures of Power Car Cabs

This section contains the proposed requirements for forward end structures of power car cabs. The forward end structure of a power car cab plays a vital role in a collision with another object. This structure must resist override, prevent the entry of fluids into occupied spaces of the cab, and allow the crash energy management system to function. The proposed requirements in paragraphs (a)-(c) are based on a specific end structure design that consists of a full-height center collision post, two side collision posts located at approximately the one-third points laterally, and two full-height corner posts. The proposal includes loading requirements that each of these structural members must withstand. In addition, the proposal permits flexibility for using other equipment designs that provide equivalent structural protection. End structures meeting these requirements will provide considerably greater protection to the train operator than provided by existing passenger equipment designs. For example, much stronger corner posts are proposed here than for Tier I passenger equipment. FRA believes these end structures help provide a degree of crashworthiness to compensate for the increased risk associated with operating at higher speeds.

The front end structure design also includes in paragraph (d) a skin requirement equivalent to that required by AAR S-580 and proposed in § 238.209 for Tier I locomotives.

§ 238.411 Rear End Structures of Power Car Cabs

The rear end structure of a power car cab provides protection to crewmembers from intrusion of locomotive machinery or trailing cars into the occupied volume as a result of a collision or derailment. The proposed requirements are based on a specific end structure design that consists of two full-height corner posts (paragraph (a)) and two full-height collision posts (paragraph (b)). The proposal includes loading requirements that each of these structural members must withstand. Further, the proposal permits flexibility for using other equipment designs that provide equivalent structural protection. The proposed rear end structure will provide considerably greater protection to the train operator than that provided by existing passenger equipment designs. Together, the front and rear end

structures proposed in this rule for a power car cab make the cab a highly survivable crash refuge.

§ 238.413 End Structures of Trailer Cars

The proposed requirements in paragraph (a) are based on a specific end structure design that consists of two full-height corner posts and two full-height collision posts. The proposal includes loading requirements that each of these structural members must withstand. The proposal also allows flexibility for other designs that provide protection structurally equivalent to the proposed design.

Paragraph (b) makes clear how the requirements proposed in paragraph (a) apply to a trailer car that consists of multiple articulated units not designed for uncoupling in other than at a maintenance shop. The end structure requirements apply only to the two ends of the entire articulated assembly of units. Paragraph (b) explains that the interior ends of the individual units of the articulated assembly need not be equipped with an end structure that meets the requirements proposed in paragraph (a). Articulated assemblies have a history of remaining in line during derailments and collisions and if not designed to be uncoupled, only the exposed ends of the entire assembly will be exposed to the risks of override. However, interior units that are merely semi-permanently coupled, but not articulated, are subject to the proposed end structure requirements in paragraph (a).

Paragraph (c) contains an additional requirement for trailer cars designed with an end vestibule. Such designs provide an opportunity for additional corner post structures inboard of the vestibule side doors. These corner posts can be supported by the side sill and therefore be structurally more substantial than the corner posts outboard of the side doors. The proposal includes loading requirements that these additional full-height corner posts must withstand. Overall, the double corner post design provides significantly increased protection to passengers in such trailer cars.

§ 238.415 Rollover Strength

This section contains the proposed requirements for the rollover strength of power cars and trailer cars. If the occupied volumes of these vehicles remain intact when they roll onto their side or roof structures, occupant injury from vehicle collapse will be avoided. The proposal essentially requires the vehicle structure to support twice the deadweight of the vehicle as it rests on

its side or roof. Minor deformations of the side and roof sheathing and smaller structural members are allowed to the extent necessary for the vehicle to be supported directly by more substantial structural members of the frame. Passenger equipment constructed to North American design practice performs well in rollover situations. FRA believes this proposal captures this design practice.

§ 238.417 Side Loads

This section contains the proposed requirements intended to resist penetration of the side structure of a passenger car by a highway or rail vehicle. The objective is to make the side of the passenger car strong enough so that the car derails rather than collapses when struck in the side by a highway or rail vehicle. If the passenger car moves sideways (derails), less structural damage and potential to injure train occupants will result.

§ 238.419 Truck-to-Car-Body and Truck Component Attachment

Paragraph (a) requires the truck-to-car-body attachment on Tier II passenger equipment to resist without failure a vertical force equivalent to 2g acting on the mass of the truck and a force of 250,000 pounds acting in any horizontal direction. The earlier discussion of the proposed truck-to-car-body attachment strength requirement in § 238.219 for Tier I passenger equipment is also applicable here.

Paragraph (b) requires that each component of the truck must remain attached to the truck when a force equivalent to 2g acting on the mass of the component is exerted in any direction on that component. Whereas paragraph (a) is intended to keep the truck attached to the car body, paragraph (b) is intended to keep truck components attached to the truck.

§ 238.421 Glazing

This section contains the proposed glazing requirements for Tier II passenger equipment. FRA believes that the higher speed of Tier II passenger equipment requires more stringent glazing standards than currently required by 49 CFR part 223.

Paragraph (a) requires each power car and trailer car to be equipped with glazing meeting the following requirements. First, under paragraph (a)(1), end-facing glazing shall resist the impact of a 12-pound solid steel sphere traveling at the maximum speed of the vehicle in which the glazing will be installed. The test must be conducted so that the sphere strikes the glazing at the same angle as an object would strike the

glazing when installed in a train. To successfully pass the test, the glazing must neither spall nor be penetrated by the sphere. This test is similar to the requirements imposed under European glazing standards for high-speed trains, and should be much more repeatable than the cinder block test specified in 49 CFR part 223.

Second, under paragraph (a)(2)(i), side-facing glazing shall resist the impact of a 12-pound solid steel sphere traveling at 15 mph and impacting at an angle of 90 degrees to the surface of the glazing, with no penetration or spall. This is a highly repeatable test that demonstrates whether side-facing glazing can protect occupants from a relatively heavy object thrown against the side of the train. This test is more stringent than the large object impact test required for side facing glazing under 49 CFR part 223.

Third, under paragraph (a)(2)(ii), side-facing exterior glazing shall resist the impact of a granite ballast stone weighing a minimum of 0.5 pounds, traveling at 75 mph, and impacting at a 90-degree angle to the glazing surface, with no penetration or spall. This is a highly repeatable test to demonstrate whether the glazing can protect occupants against impact from a common stone found along the railroad thrown at a speed slightly faster than a human could throw such an object.

Fourth, under paragraph (a)(3)(i), all exterior glazing shall resist the single impact of a 9-mm, 147-grain bullet traveling at an impact velocity of 900 feet per second, with no bullet penetration or spall. This bullet is a much more common handgun round than the 22-caliber bullet specified in 49 CFR part 223. The proposed requirement does represent a balance between the degree of bullet impact protection and window weight, however. Ballistic tests revealed that a requirement to resist a round fired at velocities typical of high-powered rifles requires a glazing thickness that creates a window weight that is impractical for use as an emergency exit.

Fifth, under paragraph (a)(3)(ii), all exterior glazing shall demonstrate anti-spalling performance by the use of a 0.001 aluminum witness plate, placed 12 inches from the glazing surface during all impact tests. The witness plate must not contain any marks from spalled glazing particles after any impact test. When impacted on the exterior surface, glazing currently used in railroad equipment tends to spall from the inside surface. Several eye injuries to crewmembers have resulted. FRA believes that the witness plates used in conducting the spalling tests to

qualify current glazing are too thick and have allowed glazing that actually spalled to pass the test. The witness plate specified in this paragraph is much thinner and therefore more sensitive to detecting spall.

Paragraph (b) requires glazing material to be marked to indicate that it has passed the testing requirements proposed in paragraph. This marking requirement is similar to that provided in 49 CFR part 223.

Paragraph (c) requires glazing frames to hold the glazing in place against all the forces which the glazing is required to resist in paragraph (a). This proposal is intended to prevent the glazing from being knocked out of its frame by the force of an object striking the glazing, even though no penetration of the glazing itself occurs. Since FRA is proposing more stringent impact testing requirements for glazing in Tier II passenger equipment than for Tier I passenger equipment, stronger glazing frames will be required to keep the glazing in place and achieve the additional safety benefit provided by the stronger glazing.

Paragraph (d) requires the glazing securement components to resist the forces due to air pressure differences caused by trains passing with the minimum separation for two adjacent tracks while traveling in opposite directions, each traveling at maximum speed. The higher speed of Tier II passenger equipment makes this a more stringent requirement than proposed for Tier I passenger equipment.

Paragraph (e) requires interior glazing to meet the minimum requirements of AS1 type laminated glass as defined in American National Standard "Safety Code for Glazing Materials for Glazing Motor Vehicles Operating on Land Highways," ASA Standard Z26.1-1966. This requirement alleviates the need for interior glazing to meet the stringent impact resistance requirements placed on exterior glazing, while ensuring that the glazing will shatter in a safe manner like automotive glazing.

Paragraph (f) requires that each vehicle be stencilled on an interior wall to indicate that it meets the glazing requirements contained in this section. This requirement is already provided for existing equipment in 49 CFR 223.17.

§ 238.423 Fuel Tanks

This section contains the proposed requirements for fuel tanks for fossil-fueled Tier II passenger equipment. FRA is proposing separate requirements for external fuel tanks, which are traditional, under the car body fuel tanks, and for internal tanks, which are built into the structure of the car body.

Paragraph (a) requires the following of external fuel tanks:

- A minimum height above the rail;
- A minimum penetration resistance for end bulkheads;
- A minimum exterior skin strength;
- A temperature range to which material properties must not degrade;
- A vent system that prevents spills in any tank orientation;
- Skid surfaces on the bottom of the tank; and
- An overall structural strength adequate to support 1½ times the dead weight of the locomotive without deformation of the tank.

This set of proposed requirements is based on investigations of accidents involving fuel tank rupture; analysis and testing of improved fuel tank designs; reports by railroads of reductions in fuel spills on locomotives built with more crashworthy fuel tanks; and an analysis of the common methods of damaging fuel tanks. FRA believes the proposed requirements will result in significantly fewer fuel spills and fewer post-collision fires. Although the proposed requirements reduce the range of a train by adding weight and reducing fuel carrying capacity, FRA does not believe that this reduced range will impact passenger train service because food and other supplies will likely need replenishing first before a train needs refueling.

Paragraph (b) requires that internal fuel tanks be a minimum height above the rail, be equipped with a vent system that prevents spills in any tank orientation, and have a minimum penetration resistance of the bulkheads and skin. Amtrak has included internal fuel tanks in the design of many new locomotives. Experience with these tanks has shown them to be much less vulnerable than external fuel tanks due to protection provided by the structure of the car body. This reduced vulnerability lessens the need for many of the requirements proposed for external fuel tanks.

§ 238.425 Electrical Systems

This section contains the proposed requirements for electrical system design. These requirements reflect common electrical safety practice and are widely recognized as good electrical design practice. They include provisions for:

- Circuit protection against surges, overload and ground faults;
- Electrical conductor sizes and properties to provide a margin of safety for the intended application;
- Battery system design to prevent the risk of overcharging or accumulation of

dangerous gases that can cause an explosion;

- Design of resistor grids that dissipate energy produced by dynamic braking with sufficient electrical isolation and ventilation to minimize the risk of fires; and
- Electromagnetic compatibility within the intended operating environment to prevent electromagnetic interference with safety-critical equipment systems and to prevent interference of the rolling stock with other systems along the right-of-way.

§ 238.427 Suspension System

Suspension system performance parameters are crucial to the safe operation of high-speed rail passenger equipment. The suspension system requirements that FRA is proposing served as safety limits for the successful demonstrations of the X-2000 and the ICE trainsets on the NEC at speeds up to 135 mph. These proposed requirements are also part of the suspension system performance requirements for Amtrak's American Flyer trainsets.

Safety requirements concerning the wheel-rail interface have traditionally been addressed as part of the track safety standards. In parallel with the Tier II Equipment Subgroup's effort to develop high-speed equipment safety standards, the RSAC Track Working Group developed an NPRM on track safety standards which includes proposed high-speed track standards. See 62 FR 36138, Jul. 3, 1997. FRA sponsored a joint meeting of the Tier II Equipment Subgroup and members of the Track Working Group focusing on the development of high-speed track standards to ensure that the two sets of standards not conflict at the wheel-rail interface, where they overlap. Overall, the two groups proposed very similar standards, but members of the Track Working Group recommended some modifications to Tier II passenger equipment standards so that these standards would dovetail with the high-speed track standards. FRA has revised the proposed Tier II passenger equipment standards accordingly, as noted in discussions below of the specific requirements of this section.

To ensure safe, stable performance and ride quality, paragraph (a) requires suspension systems to be designed to reasonably prevent wheel climb, wheel lift, rail rollover, rail shift, and a vehicle from overturning. These requirements must be met in all operating environments, and under all track and loading conditions as determined by the operating railroad. In addition, these requirements must be met under all

track speeds and track conditions consistent with the Track Safety Standards (49 CFR part 213), up to the maximum operating speed and maximum cant deficiency of the equipment. These broad suspension system performance requirements address the operation of equipment at both high speed over well maintained track and at low speed over lower classes of track. Suspension system performance requirements are needed at both high and low speeds as exemplified by recent incidents where stiff, high-speed suspension systems caused passenger equipment to derail while negotiating curves in yards at low speeds.

Compliance with paragraph (a) must be demonstrated during pre-revenue service acceptance testing of the equipment and by complying with the safety performance standards for suspension systems contained in Appendix C to this part. Because better ways to demonstrate suspension system safety performance may be developed in the future, the rule allows the use of alternative standards to those contained in Appendix C if they provide equivalent safety and are approved by the FRA Associate Administrator for Safety under the provisions of § 238.21.

Paragraph (b) requires the steady-state lateral acceleration of passenger cars to be less than 0.1g, as measured parallel to the car floor inside the passenger compartment, under all operating conditions. Passenger cars shall not operate when the steady-state lateral acceleration is 0.1g or greater. FRA originally considered limiting the cant deficiency, but Track Working Group members recommended that the steady-state lateral acceleration requirement alone is sufficient to ensure safe operation. The Tier II Equipment Subgroup concurred, and FRA is proceeding according to these recommendations.

Paragraph (c) requires each truck to be equipped with a permanently installed lateral accelerometer mounted on the truck frame. If hunting oscillations are detected, the train must be slowed. The proposal contained in the paragraph did not have the full support of the Tier II Equipment Subgroup and the Track Working Group members because of disagreement over where the accelerometer should be located.

Paragraph (d) provides ride vibration (quality) limits for vertical accelerations, lateral accelerations, and the combination of lateral and vertical accelerations. These limits must be met while the equipment is traveling at the maximum operating speed over its intended route. The limiting parameters

and the means to measure them represent the consensus recommendations of both working groups and have proven effective during the demonstrations of the X-2000 and ICE trainsets.

Paragraph (e) provides that compliance with the ride quality requirements contained in paragraph (d) be demonstrated during the equipment pre-revenue service qualification tests required under § 238.113 and § 213.345 of the proposed federal track safety standards. One of the most important objectives of pre-revenue service qualification testing is to demonstrate that suspension system performance requirements have been met.

Paragraph (f) requires bearing overheat sensors to be provided either on board the equipment or at reasonable wayside intervals. FRA prefers sensors to be on board the equipment to eliminate the risk of a hotbox that develops between wayside locations. However, FRA does recognize that onboard sensors have a history of falsely detecting overheat conditions that have caused significant operating difficulties for some passenger railroads.

§ 238.429 Safety Appliances

This section contains the proposed requirements for safety appliances for Tier II passenger equipment. FRA has attempted to simplify and clarify how the Safety Appliance Standards contained in 49 CFR part 231 and 49 U.S.C. 20302(a) will be applied to Tier II passenger equipment. The proposed requirements are basically a restatement of existing requirements but tailored specifically for application to this new and somewhat unconventional equipment. They represent the consensus recommendation of the Tier II Equipment Subgroup.

Paragraph (b) deserves special mention; it proposes to require that Tier II passenger trains be provided with a parking or hand brake that can be set and released manually and can hold the equipment on a 3-percent grade. A hand brake is an important safety feature that prevents the rolling or runaway of parked equipment.

§ 238.431 Brake System

This section contains proposed brake system design and performance requirements for Tier II passenger equipment, and, except for one provision, represents the consensus recommendation of the Tier II Equipment Subgroup. The main issue of concern among Subgroup members involved the capability of sensor technology used to monitor the application and release of brakes. Labor

representatives maintained that a technology that actually measures the force of brake shoes and pads against wheels and brake discs is required for a reliable indication of brake application and release. Railroad operators contended that this technology is not commercially available and that monitoring pressure in brake cylinders does provide a reliable indication of brake application and release, particularly when those cylinders are directly adjacent to the point where brake friction surfaces are forced together.

Aside from this issue, the rest of the proposed brake system design and performance requirements received widespread support. In fact, several of the proposed requirements were contained in written positions provided by both rail labor and management members of the Subgroup, and virtually all of the proposed requirements were discussed in the high-speed passenger equipment section of the 1994 NPRM on power brakes. See 59 FR 47693-47694, 47699-47700, and 47730. Many of the requirements proposed in this section are similar to the requirements proposed for Tier I passenger equipment in § 238.231, thus the discussion related to that section should be read in conjunction with the following discussion.

The proposal contained in paragraph (a) is virtually identical to the proposal related to the braking systems of Tier I passenger equipment in § 238.231 (a).

Paragraph (b) proposes a requirement similar to that proposed in § 238.231 (b) and is intended to protect railroad employees. FRA believes that inspectors of equipment must be able to ascertain if brakes are applied or released without placing themselves in a vulnerable position. The proposed rule allows railroads the flexibility of using a reliable indicator in place of requiring direct observation of the brake application or piston travel because the designs of many of the brake systems used on passenger equipment make direct observation of the brakes extremely difficult. Brake system piston travel or piston cylinder pressure indicators have been used with satisfactory results for many years. Although indicators do not provide 100 percent certainty that the brakes are effective, they have proven effective enough to be preferable to requiring an inspector to assume a dangerous position.

Paragraph (c) is virtually identical to the requirement proposed in § 238.231 (c), and is a fundamental brake system performance requirement that an emergency brake application feature be

available at any time and produce an irretrievable stop. This paragraph proposes an additional requirement that a means to actuate the emergency brake be provided at two locations in each unit of the train. This additional requirement ensures the availability of the emergency brake feature and is in accordance with the current available design of high-speed passenger equipment.

Paragraph (d) requires the brake system to be designed to prevent thermal damage to wheels and brake discs.

Paragraph (e) proposes requirements related to blended braking systems. These requirements are similar to those proposed in § 238.231 (j). The only additional requirement is that the operational status of the electric portion of the blended brake be displayed in the operator's cab. Operators use different train handling procedures when the electric portion of blended brake is not available. A very dangerous situation can arise when an operator expects the electric portion of the blended brake to be available and it is not. FRA believes that when operations exceed 125 mph either the train must not be used if the electric portion of the blended brake is not available, or the train operator must know that the electric portion of the blended brake is not available so he or she can be prepared to use compensating train handling procedures. Further, FRA believes that if the additional heat input to wheels or discs caused by lack of the electric portion of the blended brake causes thermal damage to these braking surfaces, then the electric portion of the blended brake should be considered a required safety feature and, unless it is available, the equipment should not be used.

Paragraph (f) requires the brake system to allow a disabled train's pneumatic brakes to be controlled by a conventional locomotive during rescue operations.

Paragraph (g) requires that Tier II passenger trains be equipped with an independent brake failure detection system that compares brake commands to brake system outputs to determine if a failure has occurred. This paragraph also proposes that the brake failure detection system report failures to the automated monitoring system, which is proposed in § 238.445, thus alerting the train operator to potential brake system degradation so that the operator can take corrective action such as slowing the train.

Paragraph (h) requires that all Tier II passenger equipment be provided with an adhesion control system designed to

automatically adjust the braking force on each wheel to prevent sliding during braking. FRA also proposes to require that the train operator be alerted in the event of a failure of this system with a wheel slide alarm that is visual or audible, or both. This proposed feature ties the adhesion control system to the automated monitoring system and prevents dangerous wheel slide flat conditions that can be caused when wheels lock during braking.

§ 238.433 Draft System

FRA is proposing that leading and trailing automatic couplers of Tier II trains be compatible with standard AAR couplers with no special adapters used. FRA believes that compatibility with standard couplers is necessary in order that a conventional locomotive could assist in the rescue of disabled Tier II passenger equipment. In addition, couplers must include an automatic coupling feature as well as an uncoupling device that complies with 49 U.S.C. chapter 203, 49 CFR part 231, and 49 CFR 232.2. FRA believes that automatic uncoupling devices are necessary in order to comply with the intent of the statute so that employees will not have to place themselves between equipment in order to perform coupling or uncoupling operations.

§ 238.435 Interior Fittings and Surfaces

This section contains proposed requirements for interior fittings and surfaces. Once survivable space is ensured by basic vehicle structural strength and crash energy management requirements, the design of interior features becomes an important factor in preventing or mitigating injuries resulting from collisions or derailments. Loose seats, equipment, and luggage are a significant cause of injuries in passenger train collisions and derailments.

Paragraphs (a) through (c) contain requirements for the design of passenger car seats and the strength of their attachment to the car body. These requirements are based on sled tests of passenger coach seats, seat tests conducted for other modes of transportation, and computer modeling to predict the results of passenger train collisions. These provisions include a requirement for shock absorbent material on the backs of seats to cushion the impact of passengers with the seats ahead of them.

Paragraph (d) contains the requirements for strength of attachment of interior fittings and is similar to that proposed in § 238.233(c).

Paragraph (e) contains a special requirement for the ultimate strength of seats and other fittings in the cab of a power car. Due to the extra strength of the cab, its structure is capable of resisting forces caused by accelerations that exceed 10g. As a result, benefit can be gained from a greater longitudinal strength requirement for seat and other interior fitting attachments. FRA is therefore proposing that seats and equipment in the cab be attached to the car body with sufficient strength to resist longitudinal forces caused by an acceleration of 12g. The lateral and vertical requirements remain 4g. This requirement does not apply to equipment located outside the cab.

Paragraphs (f) and (g) contain requirements representing good safety design practice for any type of vehicle.

FRA believes the luggage restraint requirement proposed in paragraph (h) will prevent many of the injuries caused by flying luggage that are typical of passenger train collisions and derailments.

§ 238.437 Emergency Communication

This section requires an emergency communication system within the train with back-up power, and is discussed earlier in the preamble. This safety feature will allow the train crew to provide evacuation and other instructions to passengers. Such a system can help prevent panic that can occur during emergency situations. FRA is proposing that transmission locations be located at both ends of each unit, that the locations be marked with luminescent material, and that clear instructions be provided for the use of the emergency communication system.

§ 238.439 Emergency Window Exits and Roof Hatches

Paragraph (a) contains proposed requirements that apply to emergency window exits on passenger cars. This paragraph is virtually identical to that proposed for Tier I passenger equipment in § 238.235, except for the required size of the emergency window exits. A discussion of emergency window exits and the distinction between proposed requirements for Tier I and Tier II passenger equipment is provided earlier in the preamble.

Paragraph (b) requires either a roof hatch or a clearly marked structural weak point in the roof to provide quick access for properly equipped emergency personnel. One roof hatch or structural weak point is required for each power car cab and two roof hatches or structural weak points for each passenger car. A discussion of roof hatches and structural weak points is

also provided earlier in the preamble. Such features should aid in removing passengers and crewmembers from a vehicle that is either on its side or upright in water.

Paragraph (c) is reserved for marking and operating instruction requirements.

§ 238.441 Doors

This section contains the proposed requirements for exterior doors on Tier II passenger cars. This section should be read with the discussion of emergency egress and access earlier in the preamble. The requirements in paragraph (a) are virtually identical to those proposed in § 238.237(b), except that paragraph (a)(2) requires that the status of powered, exterior side doors be displayed to the crew in the operating cab and, if door interlocks are used, the sensors to detect train motion must nominally be set at 3 mph. Such equipment is well within current technology. Paragraph (b) requires that powered, exterior side doors be connected to an emergency back-up power system. Paragraph (c) is identical to that proposed for Tier I passenger equipment in § 238.237(c). Paragraph (d) requires passenger compartment end doors to be equipped with a kick-out panel, pop-out window, or other means of egress in the event the door will not open. As discussed above, FRA considered this requirement for both Tier I and Tier II equipment, but believes such a feature may be dangerous on side doors because passengers could use the feature inappropriately and possibly exit from a moving train. However, this feature has a strong safety benefit for end doors that allow movement from car to car. These doors are not used to exit the train, and using end doors to exit to the next car is the preferred mode of evacuating a car.

Paragraph (e) is reserved for door marking and operating instruction requirements. These requirements are currently being addressed in the proposed rule on passenger train emergency preparedness. See 62 FR 8330, Feb. 24, 1997.

§ 238.443 Headlights

Because of the high speeds at which Tier II passenger equipment operates, FRA is proposing that a headlight be directed farther in front of the train to illuminate a person than is currently required for existing equipment under 49 CFR 229.125(a). A Tier II passenger train will travel distances more quickly than a Tier I passenger train, and the train operator will have less time to react thereby necessitating earlier awareness of objects on the track.

§ 238.445 Automated Monitoring

This section contains the proposed requirements for automated monitoring of the status or performance of various safety-related systems. Investigations of past passenger train accidents reveal that many of them were either fully or partly caused by human error. The faster operating speeds of Tier II passenger equipment means that the train operator will have less time to evaluate and react to potentially dangerous situations. The potential for accidents is increased. Automated monitoring systems can decrease the risk of accidents by alerting the operator to abnormal conditions and advising the operator as to necessary corrective action. Such systems can even be designed to take corrective action automatically in certain situations. As a result, FRA is proposing that a Tier II passenger train be equipped with an automated system to monitor various train systems and components.

Paragraph (a) requires the train to be equipped to monitor the performance of a minimum set of safety-related systems and components. The monitoring system can also be used to provide information for trouble-shooting and maintenance and to accumulate reliability data to form the basis for setting required periodic maintenance intervals.

Paragraph (b) requires the operator to be alerted when any of the monitored parameters are out of predetermined limits. FRA does not intend to remove the decision from the operating railroad for when automatic intervention is necessary. However, the operating railroad should have a valid basis for either leaving response in the hands of the train operator or making corrective action automatic.

Paragraph (c) requires the monitoring system to be designed with an automatic self-test feature that notifies the operator that the monitoring capability is functioning correctly and alerts the operator that a system failure has occurred. Because operators can become dependent on automated monitoring systems, they need to know when their vigilance must be heightened to compensate for a malfunction in this automated safety tool.

§ 238.447 Operator's Controls and Cab Layout

In the ANPRM, FRA offered for comment a detailed set of requirements concerning cab control systems and interior safety features for consideration by the industry. However, several members of the Working Group believed that a number of these requirements

involved ergonomic issues which do not directly affect safety. Nonetheless, FRA is proposing in this section extensive requirements for Tier II cab interior features. The speeds at which Tier II equipment will operate will press human reaction time, and such features will contribute to the ability of the crew to operate the train as safely as possible.

Paragraph (g)(1) deserves special mention; it requires that each seat provided for a crewmember be equipped with a single-acting, quick-release lap belt and shoulder harness as defined in § 571.209 of this title. This proposed requirement is mentioned earlier in the preamble discussion of train interior safety features.

Subpart F—Inspection, Testing, and Maintenance Requirements for Tier II Passenger Equipment

Currently, there is no operating history with regard to Tier II equipment, and thus there are no regulations or industry standards establishing detailed testing, inspection, or maintenance procedures, criteria, and intervals for the equipment. The railroads and the rail labor organizations differ on the approach that should be taken in establishing inspection, testing, and maintenance requirements. Railroads have long appealed to FRA to move away from detailed "command and control" regulations and instead to provide broad safety performance requirements that afford railroads wide latitude to develop the operational details. Rail labor organizations, on the other hand, believe that specific inspection, testing, and maintenance criteria that cannot be unilaterally changed by railroads are the only way that safe railroad operation can be assured.

FRA believes that the introduction of a new type of passenger train equipment offers the opportunity for a fresh start, where perhaps both of these seemingly conflicting concerns can be resolved. FRA proposes general guidelines on the process to be used by the operating railroad, together with the system developer, to develop an inspection, testing, and maintenance program. The operating railroad and the system developer together have the best information, expertise, and resources necessary to develop the details of an effective inspection, testing, and maintenance program. The operating railroad is thereby granted some latitude to develop the operational details of the program, using the system safety process to justify the safety decisions that are made. However, FRA proposes to exercise final approval of the inspection, testing, and maintenance

program proposed by the operating railroad; rail labor organizations will be given an opportunity to discuss their concerns with FRA during the approval process set forth in § 238.505. Tier II equipment must not be used prior to FRA approval of an inspection, testing, and maintenance program. Further, FRA proposes to enforce the safety-critical inspection, testing, and maintenance procedures, criteria, and maintenance intervals that result from the approval process.

§ 238.501 Scope

This subpart contains inspection, testing, and maintenance requirements for passenger equipment that operates at speeds exceeding 125 mph but not exceeding 150 mph.

§ 238.503 Inspection, Testing, and Maintenance Requirements

This section requires the establishment by the railroad of an FRA-approved inspection, testing, and maintenance program based on a daily complete brake system test and mechanical safety inspection of the equipment performed by qualified mechanical inspectors, coupled with a periodic maintenance program based on a system safety analysis. Although paragraph (a) proposes some basic requirements to be included in a program, FRA does not intend to prescribe every detail of what a program must contain. FRA proposes to require the operating railroad to develop and justify the details of any program it adopts based on the specific safety needs and operating environment of the high speed rail system being developed.

Paragraph (b) would make enforceable, subject to civil penalties and other enforcement action, the safety-critical inspection, testing, and maintenance requirements that are identified in the railroad's program and approved by FRA. "Safety-critical" requirements are those that, if not fulfilled, increase the risk of damage to equipment or personal injury to a passenger, crewmember, or other person." See § 238.5. Under paragraph (k), the railroad must identify which items in its inspection, testing, and maintenance program are safety-critical. The railroad must submit the program to FRA under the procedures of § 238.505. Once these programs are approved by FRA, this section proposes to make those items identified as safety-critical enforceable by FRA. FRA agrees with labor representatives to the Working Group that safety standards are stronger when they contain specific provisions that can be enforced.

Paragraph (c) requires that the operating railroad develop an inspection, testing, and maintenance program to ensure that all systems and components of Tier II passenger equipment are free of general conditions that endanger the safety of the crew, passengers, or equipment. FRA has identified the various conditions enumerated in paragraph (c) that would need to be addressed in the railroad's program. Consequently, FRA has attempted to define what the inspection, testing, and maintenance program must accomplish, but not how to accomplish it.

Paragraph (d) contains the more specific requirements that any inspection, testing, and maintenance program must incorporate. In paragraph (d)(1), FRA proposes that Tier II equipment receive the equivalent of a Class I brake test, as described in § 238.313, before its departure from an originating terminal and every 1,500 miles after that or once each calendar day the equipment remains in service. The test must be performed by a qualified mechanical inspector. For example, a Tier II train must receive the equivalent of a Class I brake test at its originating terminal and must receive a second Class I equivalent brake test after traveling 1,500 miles from the time of the original Class I brake test, whether or not it is the same calendar day. Furthermore, a Tier II train must receive the equivalent of a Class I brake test each calendar day it is used in service even if it has not traveled 1,500 miles since the last Class I equivalent brake test. Due to the speeds at which this equipment is permitted to operate, FRA believes that a comprehensive brake test must be performed prior to the equipment being placed in service.

Paragraph (d)(2) proposes that a complete exterior and interior mechanical inspection be conducted by qualified mechanical inspectors at least once each calendar day that the equipment is used. In order to perform a quality mechanical inspection, railroads must be provided some flexibility in determining the locations where these inspections can best be performed. FRA believes that permitting railroads to conduct these mechanical inspections at any time during the calendar day provides adequate flexibility to move equipment to appropriate locations. Trains that miss a scheduled Class I brake test or mechanical inspection due to a delay en route may proceed to the location where the Class I brake test or mechanical inspection was scheduled to be performed. FRA recognizes that, due to the specialized nature of this

equipment, proper inspections can only be conducted at a limited number of locations. FRA also recognizes that trains become delayed en route due to problems which are not readily foreseeable. Thus, FRA proposes to permit the continued use of such equipment to the location where the required inspection was scheduled to be performed.

Paragraph (e) restates § 238.15 and provides a cross-reference to that section. The paragraph provides that trains developing en route defective, inoperative, or insecure primary brake equipment be moved in accordance with the requirements of that section.

Paragraph (f) restates § 238.17 and adds a narrow exception to that section. The paragraph proposes that Tier II equipment that develops a defective condition not related to the primary brake be moved and handled in accordance with the requirements contained in § 238.17, with one exception. The exception to these requirements applies to a failure of the secondary portion of the brake that occurs en route. In those circumstances, FRA proposes that the train may proceed to the next scheduled equivalent Class I brake test at a speed no greater than the maximum safe operating speed demonstrated through analysis and testing for braking with the friction brake alone. At that location the brake system shall be restored to 100 percent operation before the train continues in service. This proposal allows extensive flexibility for the movement of equipment with defective brakes, but also contains a hard requirement that all brake components be repaired and the brake system, including secondary brakes, be restored at the location of the train's next major brake test. FRA believes that this proposal recognizes the secondary role played by the electric portion of blended brakes. If the railroad has demonstrated that the friction brake alone can stop the train within signal spacing without thermal damage to braking surfaces, then the train may be used at normal maximum speed in the event of an electric brake failure. This proposal essentially limits the use of trains without available secondary braking systems to no more than 48 hours. FRA believes that § 238.17 strikes the correct balance between the need of railroads to transport passengers to their destination and the need to have equipment with defects that could lead to more serious safety problems quickly repaired. This proposed requirement places a heavy responsibility on qualified mechanical inspectors to

exercise their judgment on when and how equipment is safe to move.

Paragraph (g) would require that scheduled maintenance intervals be based on the analysis conducted as part of the system safety program and approved by FRA under the procedures of § 238.505. FRA proposes to allow the maintenance intervals for safety-critical components to be changed only when justified by accumulated acceptable operating data. Changes in maintenance cycles of safety-critical components must be based on verifiable data made available to all interested parties and shall be reviewed by FRA. This proposal is another attempt to balance the needs of the operating railroad to run efficiently and the concern of rail labor organizations that railroads have the ability to unilaterally make safety decisions. For a new system with no operating history, a formal system safety analysis is the only justifiable way to set initial maintenance intervals. The proposal recognizes that as time passes and an operating history is developed, a basis for changing maintenance intervals can be established. However, the decision to make these changes must have the participation of all the affected parties.

Paragraph (h) would require that the operating railroad establish a training, qualification, and designation program as defined in the training program plan under § 238.111 to qualify individuals to perform safety inspections, tests, and maintenance on the equipment. If the railroad deems it safety-critical, then only qualified individuals may perform the safety inspection, test, or maintenance of the equipment. FRA does not prescribe a detailed training program or qualification and designation process. Those details are left to the operating railroad, but FRA must approve the program proposed by the operating railroad under procedures of § 238.505.

Under paragraph (i), the operating railroad would be obliged to establish standard procedures for performing all safety-critical inspections, tests, maintenance, or repair. This paragraph proposes various broad requirements relating to the content and enforceability of the standard operating procedures. FRA has drawn on the experiences of other heavy industries and in the military, where inherently dangerous tasks are common, which have proven that standard operating procedures are an effective tool in reducing work-related injuries. Further, standard operating procedures can form the basis for periodic safety refresher training. FRA does not propose to prescribe the detailed procedures to be

used. The proposed rule is designed to have the detailed procedures developed by those with most knowledge of how to safely perform the tasks: the operators and employees.

Paragraph (j) proposes to require that the operating railroad establish an inspection, testing, and maintenance quality control program enforced by railroad or contractor supervisors. In essence, this creates the need for the operating railroad to perform spot checks of the work performed by its employee and contract equipment maintainers to ensure that the work is performed in accordance with established procedures and Federal requirements. FRA believes this is an important management function that has a history of being neglected in the railroad industry.

Paragraph (k) requires the operating railroad to identify each inspection and testing procedure and criterion and each maintenance interval that the railroad considers safety-critical.

§ 238.505 Program Approval Procedure

This section contains the procedures a railroad shall follow in securing FRA approval of its program.

Subpart G—Introduction of New Technology to Tier II Passenger Equipment

§ 238.601 Scope

This subpart contains proposed general requirements for introducing new technology that affects safety systems of "existing Tier II passenger equipment," which is defined as Tier II passenger equipment that has been approved for revenue service by FRA under § 238.21. As part of the development of the ANPRM in this docket, FRA discussed extensive requirements for the introduction of new technology. During Working Group meetings, various group members pointed out that the requirements presented by FRA were very similar to the requirements of the system safety program. These members suggested that the proposed rule could be simplified and made more concise if the system safety process were used to introduce new technology to existing Tier II equipment. FRA agrees with this suggestion. FRA may determine that it is best to integrate subpart G with § 238.113. FRA invites comments from interested parties on this possible change.

§ 238.603 Process to Introduce New Technology

Paragraph (a) requires a major upgrade or introduction of new

technology that affects the performance of an existing Tier II passenger equipment safety system to be designed and implemented using the system safety process prescribed in § 238.101. This proposed requirement implements the suggestions of Working Group members.

Paragraph (b) requires railroads to follow the procedures set forth in § 238.21 and obtain FRA's special approval of a pre-revenue service acceptance testing plan for the existing Tier II passenger equipment with the upgrade or new technology containing all the elements prescribed in § 238.113 prior to executing the plan.

Paragraph (c) requires railroads to complete a pre-revenue service demonstration of the existing equipment with the upgrade or new technology in accordance with the FRA approved plan, to fulfill all other requirements of § 238.113, and obtain special approval from FRA pursuant to § 238.21 prior to using the Tier II equipment with the upgrade or new technology in revenue service. FRA considers these requirements extremely important to prevent unknown safety problems from being introduced along with the new technology.

Appendix A—Schedule of Civil Penalties

This appendix is being reserved until the final rule. At that time it will include a schedule of civil penalties to be used in connection with this part. Because such penalty schedules are statements of policy, notice and comment are not required prior to their issuance. See 5 U.S.C. 553(b)(3)(A). Nevertheless, commenters are invited to submit suggestions to FRA describing the types of actions or omissions under each regulatory section that would subject a person to the assessment of a civil penalty. Commenters are also invited to recommend what penalties may be appropriate, based upon the relative seriousness of each type of violation.

Regulatory Impact

Executive Order 12866 and DOT Regulatory Policies and Procedures

This proposed rule has been evaluated in accordance with existing policies and procedures and is considered to be significant under both Executive Order 12866 and DOT policies and procedures (44 FR 11034; Feb. 26, 1979). FRA has prepared and placed in the docket a regulatory evaluation of the proposed rule. This evaluation estimates the costs and

consequences of the proposed rule as well as its anticipated economic and safety benefits. It may be inspected and photocopied during normal business hours by visiting the FRA Docket Clerk at the Office of Chief Counsel, FRA, Seventh Floor, 1120 Vermont Avenue, N.W., in Washington, D.C. Photocopies may also be obtained by submitting a written request by mail to the FRA Docket Clerk at the Office of Chief Counsel, Federal Railroad Administration, 400 Seventh Street, S.W., Mail Stop 10, Washington, D.C. 20590.

FRA expects that overall the proposed rule will save the passenger rail industry a Net Present Value (NPV) of approximately \$41 million over the next 20 years. The estimated NPV of the total 20-year costs associated with the proposed rule is \$41,064,095. The estimated NPV of the total 20-year savings (economic benefits) expected to accrue to the industry from the proposed rule is \$81,612,874. For some passenger rail operators, the total costs incurred will exceed the total cost savings. For others, the cost savings will outweigh the costs.

The following table contains estimated 20-year costs and savings associated with the proposed requirements.

Requirement category	Cost
System Safety Program/Plan:	
Initial Filing	\$ 359,575
Modifications	101,974
Auditability/Tracking	159,611
Fire Protection:	
New equipment	497,509
Existing equipment (see discussion below)	622,486
Inspection, Testing, and Maintenance Program	525,247
Training Course Development	163,844
Training	3,778,176
Pre-Revenue Service Testing	496,281
Total—System Safety	6,704,703
General Design Requirements—Tier I:	
Anti-Climbing Mechanism & Link	65,948
Forward Facing End Structure/Collision Posts	1,745,407
Rollover Strength	60,927
Glazing	244,769
Brakes—ease of inspection	229,390
Interior Fittings	466,449
Emergency Lighting	1,483,162
Side Doors	3,400,297
Total—Design Requirements	7,696,349
Mechanical Inspections:	
Daily Exterior Mechanical Inspections	12,526,320
Daily Interior Mechanical Inspections	1,567,829
Total—Inspections	22,666,895
Brake Inspection, Testing, and Maintenance:	
Periodic MU Brake Maintenance	(20,052,750)
Periodic Coach Brake Maintenance	(5,468,750)
Periodic Cab Car Brake Maintenance	(6,158,448)
1,500-Mile Inspection	(36,019,648)
Class IA Brake Tests	(3,997,281)

Requirement category	Cost
Class II Brake Tests	3,996,147
Total—Brakes	(67,700,730)
Movement of Defective Equipment	(9,915,997)
Total Net Impact	(40,548,780)

The costs of performing fire safety analyses of existing equipment are included in the calculations above. However, the costs of modifying equipment to reduce the risk of personal injuries as required by the proposed rule are not included in the above figures. These costs could total between \$8.75 to \$14 million. The costs depend on the results of the proposed analyses, which cannot be accurately predicted. Consequently, the total net impact of the proposed rule could be a savings of \$26,548,780.

In the last six years there have been at least six passenger train accidents which resulted in more than one train occupant fatality. FRA does not know the severity or number of commuter or intercity passenger train accidents that will occur in the future. Although passenger railroads offer the travelling public one of the safest forms of transportation available—in the five-year period 1991–1995 there were 1.07 passenger fatalities per billion passenger miles—the potential for injuries and loss of life in certain situations is very high. FRA believes that the proposed rule represents a cost-effective approach to providing a reasonable level of protection against known threats to human life. Accordingly, FRA believes that it is reasonable to expect that the measures called for in this proposal would prevent or mitigate the severity of casualties greater in value than the costs of complying with the proposed requirements.

FRA is allowing 60 days for comments and invites public comment on the issue of regulatory impact, and in particular any impact the proposed rule may have on small entities. FRA seeks comments or data, or both, to help identify or quantify other factors that

may affect the benefits or costs of the proposal, including alternatives that were not explored by the Working Group and any costs or benefits associated with such alternatives.

Regulatory Flexibility Act

The Regulatory Flexibility Act of 1980 (5 U.S.C. 601 *et seq.*) requires an assessment of the impacts of proposed rules on small entities. FRA has conducted a regulatory flexibility assessment of this rule's impact on small entities, and the assessment has been placed in the public docket for this rulemaking. This proposed rule affects intercity passenger and commuter railroads, and the proposed provisions applicable to private cars may affect other entities as well.

Entities impacted by the proposed rule are principally governmental jurisdictions or transit authorities, which are not small for purposes of the United States Small Business Administration (*i.e.*, no entity operates in a locality with a population of under 50,000 people). Commuter railroads are part of larger transit organizations that receive Federal funds. FRA does not expect that smaller commuter railroads will be affected disproportionately. The level of costs incurred by each organization should vary in proportion to the organization's size. For instance, railroads with fewer employees and passenger equipment will have lower costs associated with employee training and the inspection, testing, and maintenance of passenger equipment.

Tourist, scenic, historic, and excursion railroad operations are excepted from the proposed rule. Entities devoted principally to such operations are smaller railroads. A joint FRA/industry working group formed

under RSAC is currently developing recommendations regarding the applicability of FRA regulations, including this one, to tourist, scenic, historic, and excursion railroads. After appropriate consultation with the excursion railroad associations takes place, passenger equipment safety requirements for these operations may be proposed by FRA that are different from those affecting other types of passenger train operations.

A few provisions of the proposed rule apply to private rail cars. These consist of requirements concerning protection against personal injury; rim-stamped straight-plate wheels; suspension system safety; safety appliances; brake system safety; mechanical inspections; and brake inspection, testing, and maintenance. FRA has sought to minimize the burden of the proposed rule on private cars as much as possible, while considering the safety concerns associated with the use of private rail cars in passenger trains operated by railroads subject to the proposed rule. FRA solicits comments or data, or both, to identify the impacts of these provisions to the extent that those affected by such provisions are small entities.

Paperwork Reduction Act

The proposed rule contains information collection requirements. FRA has submitted these information collection requirements to the Office of Management and Budget (OMB) for review and approval in accordance with the Paperwork Reduction Act of 1995 (44 U.S.C. 3501 *et seq.*). The sections that contain the new information collection requirements and the estimated time to fulfill each requirement are as follows:

CFR section	Respondent universe	Total annual responses	Average time per response	Total annual burden hours	Total annual burden cost
216.14—Special notice for repairs—passenger equipment.	17 railroads	12 letters	1 hour	12 hours	\$408
238.7—Waivers	17 railroads	12 waivers	2 hours	24 hours	816
238.15—Movement of passenger equipment with power brake defects, and 238.17—Movement of passenger equipment with other than power brake defects.	17 railroads	408 cards/tags	5 minutes	34 hours	1,020
Conditional requirement	17 railroads	200 events	3 minutes	10 hours	300

CFR section	Respondent universe	Total annual responses	Average time per response	Total annual burden hours	Total annual burden cost
238.19—Reporting and tracking defective passenger equipment.	17 railroads	N/A	Usual and customary procedure.	N/A	N/A
List of power brake repair points	1 railroad	1 list	2 hours	2 hours	68
Amendments to list	1 railroad	1 update	1 hour	1 hour	34
238.21/238.115/238.223(a)/ 238.309(2)/238.311(a)/238.427(2)					
Petitions for special approval of alternative standard.	17 railroads	1 petition	16 hours	16 hours	544
Petitions for special approval of pre-revenue service acceptance testing plan.	17 railroads	1 petition	24 hours	24 hours	816
Statement of interest in reviewing special approvals.	Unknown	2 statements	1 hour	2 hours	68
Comments on the petitions	Unknown	2 comments	1 hour	2 hours	122
238.103—General system safety requirements.	17 railroads	17 plans	433 hours	7,361 hours	355,351
Amendments to System Safety Plan.	17 railroads	17 amendments	11 hours	187 hours	97,801
Traceability and Auditability	17 railroads	17 documents	150 hours	2,550 hours	86,700
238.105—Fire protection program					
238.115—Fire safety Plan	6 equipment manufacturers.	4.8 (5 yr. average)	224 hours	1,075 hours	75,725
Subsequent equipment orders	6 equipment manufacturers.	4.8 (5 yr. average)	60 hours	288 hours	28,800
Preliminary fire safety analysis	17 railroads	17 documents	128 hours	2,184 hours	451,344
Final fire safety analysis	16 railroads	5.3 documents (3 yr. average).	68 hours	795 hours	79,467
Fire safety analysis on equipment transfer.	17 railroads	1 document	8 hours	8 hours	800
Certification	6 equipment manufacturers.	6 certifications	120 hours	720 hours	72,000
238.107—Software safety plan	17 railroads	N/A	Usual and customary procedure.	N/A	N/A
238.109—Inspection, testing, and maintenance program					
Program	17 railroads	N/A	Usual and customary procedure.	N/A	N/A
Maintenance intervals	17 railroads	1 change	88 hours	88 hours	3,208
Standard procedures for safely performing inspection, testing, and maintenance or repairs.	17 railroads	17 procedures	96 hours	1,632	62,832
Subsequent years—new railroads.	1 railroad	1 procedure	96 hours	96 hours	3,696
Subsequent years—railroad annual review and necessary modifications.	17 railroads	17 amendments	19 hours	323 hours	12,359
New equipment purchases	6 equipment manufacturers.	4.8 designs (5 yr. average)	120 hours	576 hours	57,600
238.111 Training, qualification, and designation program					
Training employees to perform brake-related inspections, tests, or maintenance.	17 railroads	N/A	Usual and customary procedure.	N/A	N/A
Training employees to perform daily mechanical inspections.	17 railroads	5,950 employees/235 instructors.	2 hours	12,376 hours	368,900
Development of Training Program.	17 railroads	17 programs	520 hours	8,840 hours	282,880
Record keeping	17 railroads	5,950 records	3 minutes	298 hours	10,132
238.113—Pre-revenue service acceptance testing plan.	6 equipment manufacturers.	4.8 plans (5 yr. average)	200 hours	960 hours	83,328
Subsequent equipment orders	6 equipment manufacturers.	4.8 plans (5 yr. average)	60 hours	288 hours	22,464
Previously used equipment	6 equipment manufacturers.	4.8 plans (5 yr. average)	60 hours	288 hours	22,464
238.231—Brake System Identify and mark emergency brake.	N/A	N/A	Usual and customary procedure.	N/A	N/A
238.239—Automated monitoring	17 railroads	17 documents	2 hours	34 hours	1,156

CFR section	Respondent universe	Total annual responses	Average time per response	Total annual burden hours	Total annual burden cost
238.303—Exterior calendar day mechanical inspection of passenger cars and unpowered vehicles used in passenger trains.	N/A	N/A	Usual and customary procedure.	N/A	N/A
238.305—Interior calendar day mechanical inspection of passenger cars	N/A	N/A	Usual and customary procedure.	N/A	N/A
Stenciling or marking emergency brake valve.	N/A	N/A	Usual and customary procedure.	N/A	N/A
Stenciling or marking high voltage equipment.	N/A	N/A	Usual and customary procedure.	N/A	N/A
Tagging of defective doors	9 railroads	540 tags	1 minute	9 hours	306
238.307—Periodic mechanical inspection of passenger cars.	N/A	N/A	Usual and customary procedure.	N/A	N/A
238.309—Records of periodic maintenance.	N/A	N/A	Usual and customary procedure.	N/A	N/A
238.313—Class I Brake Test	N/A	N/A	Usual and customary procedure.	N/A	N/A
238.403—Crash energy management requirements.	1 railroad	1 analysis	120 hours	120 hours	12,000
238.405—Longitudinal static compressive strength.	17 railroads	1 design	20 hours	20 hours	680
238.421—Gazing	N/A	N/A	Usual and customary procedure.	N/A	N/A
Marking of glazing material	N/A	N/A	Usual and customary procedure.	N/A	N/A
Stenciling requirement	N/A	N/A	Usual and customary procedure.	N/A	N/A
238.431—Brake System	1 railroad	1 analysis	40 hours	40 hours	1,360
238.437—Emergency communication	3 car manufacturers	3 instructions	1 hour	3 hours	90
238.439—Emergency window exits and roof hatches—Marking.	3 car manufacturers	16 cars marked	15 minutes	4 hours	120
238.503—Inspection, testing, and maintenance requirements	N/A	N/A	Usual and customary procedure.	N/A	N/A
238.505—Program approval procedures	N/A	N/A	Usual and customary procedure.	N/A	N/A
Submission of program	1 railroad	1 program	80 hours	80 hours	2,720
Amendments to program	1 railroad	1 amendment	8 hours	8 hours	272
Comments	4 unions/individuals	4 comments	1 hour	4 hours	244
Approval	N/A	N/A	No disapprovals expected at this time.	N/A	N/A
238.603—Process to introduce new technology.	1 railroad	1 plan	100 hours	100 hours	3,400
Appendix B to Part 238—Labeling requirement.	5–6 seat manufacturers.	N/A	Usual and customary procedure.	N/A	N/A

All estimates include the time for reviewing instructions; searching existing data sources; gathering or maintaining the needed data; and reviewing the information. Pursuant to 44 U.S.C. 3506(c)(2)(B), FRA solicits comments concerning: whether these information collection requirements are necessary for the proper performance of the functions of FRA, including whether the information has practical utility; the accuracy of FRA's estimates of the burden of the information collection requirements; the quality, utility, and clarity of the information to be

collected; and whether the burden of collection of information on those who are to respond, including through the use of automated collection techniques or other forms of information technology, may be minimized. For information or a copy of the paperwork package submitted to OMB contact Ms. Gloria Swanson Eutsler at 202-632-3318.

Organizations and individuals desiring to submit comments on the collection of information requirements should direct them to the Office of Management and Budget, Attention:

Desk Officer for the Federal Railroad Administration, Office of Information and Regulatory Affairs, New Executive Office Building, 726 Jackson Place, N.W., Washington, D.C. 20503, and should also send a copy of their comments to Ms. Gloria Swanson Eutsler, Federal Railroad Administration, 400 Seventh Street, S.W., Washington, D.C. 20590.

OMB is required to make a decision concerning the collection of information requirements contained in this NPRM between 30 and 60 days after publication of this document in the

Federal Register. Therefore, a comment to OMB is best assured of having its full effect if OMB receives it within 30 days of publication. The final rule will respond to any OMB or public comments on the information collection requirements contained in this proposal.

FRA is not authorized to impose a penalty on persons for violating information collection requirements which do not display a current OMB control number, if required. FRA intends to obtain current OMB control numbers for any new information collection requirements resulting from this rulemaking action prior to the effective date of a final rule. The OMB control number, when assigned, will be announced by separate notice in the **Federal Register**.

Environmental Impact

FRA has evaluated these proposed regulations in accordance with its procedures for ensuring full consideration of the environmental impact of FRA actions, as required by the National Environmental Policy Act (42 U.S.C. 4321 *et seq.*), and related directives. This notice meets the criteria that establish this as a non-major action for environmental purposes.

Federalism Implications

This proposed rule has been analyzed in accordance with the principles and criteria contained in Executive Order 12612, and it has been determined that the proposed rule does not have sufficient federalism implications to warrant the preparation of a Federalism Assessment. The fundamental policy decision providing that Federal regulations should govern aspects of service provided by municipal and public benefit corporations (or agencies) of State governments is embodied in the statute quoted above (49 U.S.C. 20133). Further, FRA has consulted with commuter authorities in developing this proposed rule.

Request for Public Comments

FRA proposes to adopt a new part 238 and to amend parts 216, 223, 229, 231, and 232 of title 49, Code of Federal Regulations, as set forth below. FRA solicits comments on all aspects of the proposed rule whether through written submissions, participation in the public hearing, or both. FRA may make changes in the final rule based on comments received in response to this proposed rule.

List of Subjects

49 CFR Part 216

Railroad safety, Special notice for repairs.

49 CFR Part 223

Railroad safety, Glazing standards.

49 CFR Part 229

Railroad safety, Railroad locomotive safety.

49 CFR Part 231

Railroad safety, Railroad safety appliances.

49 CFR Part 232

Railroad safety, Railroad power brakes.

49 CFR Part 238

Railroad safety, Railroad passenger equipment.

The Proposed Rule

In consideration of the foregoing, FRA proposes to amend chapter II, subtitle B of title 49, Code of Federal Regulations as follows:

PART 216—[AMENDED]

1. The authority citation for part 216 is revised to read as follows:

Authority: 49 U.S.C. 20102–20104, 20133, 20137–20138, 20141, 20143, 20301–20302, 20701–20702, 21301–21302, 21304; 49 CFR 1.49(c), (m).

2. Section 216.1(a) is revised to read as follows:

§ 216.1 Application.

(a) This part applies, according to its terms, to each railroad that uses or operates—

(1) A railroad freight car subject to part 215 of this chapter;

(2) A locomotive subject to 49 U.S.C. chapter 207 (49 U.S.C. 20701–20703); or

(3) Railroad passenger equipment subject to part 238 of this chapter.

* * * * *

3. Section 216.3(b) is amended by removing the phrase "section 206 of the Federal Railroad Safety Act of 1970 (45 U.S.C. 435)" and adding in its place the phrase "49 U.S.C. 20105".

4. Section 216.5(c) is amended by adding after "216.13," "216.14,".

5. The first sentence of § 216.13(a) is amended by removing the phrase "the FRA Locomotive Inspection Regulations set forth in part 230" and by adding in its place the phrase "the FRA Railroad Locomotive Safety Standards set forth in part 229 of this chapter or the FRA Railroad Locomotive Inspection Regulations set forth in part 230 of this chapter". The third sentence of § 216.13(a) is amended by removing the phrase "part 230" and adding in its place the phrase "parts 229 and 230".

6. Section 216.14 is added to read as follows:

§ 216.14 Special notice for repairs—passenger equipment.

(a) When an FRA Motive Power and Equipment Inspector or a State Equipment Inspector determines that railroad passenger equipment is not in conformity with one or more of the requirements of the FRA Passenger Equipment Safety Standards set forth in part 238 of this chapter and that it is unsafe for further service, he or she notifies the railroad in writing that the equipment is not in serviceable condition. The Special Notice sets out and describes the defect or defects that cause the equipment to be in unserviceable condition. After receipt of the Special Notice, the railroad shall remove the equipment from service until it is restored to serviceable condition. The equipment may not be deemed in serviceable condition until it complies with all applicable requirements of part 238 of this chapter.

(b) The railroad shall notify in writing the FRA Regional Administrator for the FRA region in which the Special Notice was issued when the equipment is returned to service, specifying the repairs completed.

(c) Railroad passenger equipment subject to a Special Notice may be moved from the place where it was found to be unsafe for further service to the nearest available point where the equipment can be repaired, if such movement is necessary to make the repairs. However, the movement is subject to the further restrictions of §§ 238.15 and 238.17 of this chapter.

§ 216.1 [Amended]

7. Section 216.17(a) is amended as follows:

a. By adding, after "216.13", "216.14,";

b. By adding, after the word "locomotive," in the third sentence, the phrase "railroad passenger equipment,"; and

c. By revising the fifth sentence to read as follows:

"If upon reinspection, the railroad freight car, locomotive, or passenger equipment is found to be in serviceable condition, or the track is found to comply with the requirements for the class at which it was previously operated by the railroad, the FRA Regional Administrator or his or her agent immediately notifies the railroad, whereupon the restrictions of the Special Notice cease to be effective."

8. In subpart B of part 216, the phrases "the FRA Regional Director for Railroad Safety", "the FRA Regional Director of Railroad Safety", "a Regional Director" and "the Regional Director" are removed, and the phrase "the FRA Regional Administrator" is added in their place.

PART 223—[AMENDED]

9. The authority citation for part 223 is revised to read as follows:

Authority: 49 U.S.C. 20102–20103, 20133, 20701–20702, 21301–21302, 21304; 49 CFR 1.49(c), (m).

10. Section 223.3 is amended by adding paragraph (c) to read as follows:

§ 223.3 Application.

* * * * *

(c) Except for § 223.9(d), this part does not apply to Tier II passenger equipment as defined in § 238.5 of this chapter (*i.e.*, passenger equipment operating at speeds exceeding 125 mph but not exceeding 150 mph).

PART 229—[AMENDED]

11. The authority citation for part 229 is revised to read as follows:

Authority: 49 U.S.C. 20102–20103, 20133, 20137–20138, 20143, 20701–20703, 21301–21302, 21304; 49 CFR 1.49(c), (m).

12. Section 229.3 is amended by revising new paragraphs (a), (d), and (e) to read as follows:

§ 229.3 Applicability.

(a) Except as provided in paragraphs (b) through (e) of this section, this part applies to all standard gage railroads.

(b) * * *

(c) Paragraphs (a), (b), and (d) through (h) of § 229.125 do not apply to Tier II passenger equipment as defined in § 238.5 of this chapter (*i.e.*, passenger equipment operating at speeds exceeding 125 mph but not exceeding 150 mph).

(d) On or after January 1, 1998, paragraphs (a)(1) and (b)(1) of § 229.141 do not apply to "passenger equipment" as defined in § 238.5 of this chapter that is subject to part 238 of this chapter.

(e) Paragraphs (a)(2) through (a)(4), and (b)(2) through (b)(4) of § 229.141 do not apply to "passenger equipment" as defined in § 238.5 of this chapter that is subject to part 238 of this chapter and placed in service for the first time on or after January 1, 1998.

PART 231—[AMENDED]

13. The authority citation for part 231 is revised to read as follows:

Authority: 49 U.S.C. 20102–20103, 20131, 20301–20303, 21301–21302, 21304; 49 CFR 1.49 (c), (m).

14. Section 231.0 is amended by redesignating paragraphs (c) through (e) as paragraphs (d) through (f), respectively; by revising paragraph (a); and by adding a new paragraph (c) to read as follows:

§ 231.0 Applicability and penalties.

(a) Except as provided in paragraphs (b) and (c) of this section, this part applies to all standard gage railroads.

(b) * * *

(c) Except for the provisions governing uncoupling devices, this part does not apply to Tier II passenger equipment as defined in § 238.5 of this chapter (*i.e.*, passenger equipment operating at speeds exceeding 125 mph but not exceeding 150 mph).

* * * * *

PART 232—[AMENDED]

15. The authority citation for part 232 is revised to read as follows:

Authority: 49 U.S.C. 20102–20103, 20133, 20141, 20301–20303, 20306, 21301–21302, 21304; 49 CFR 1.49 (c), (m).

16. Section 232.0 is amended by redesignating paragraphs (c) through (e) as paragraphs (d) through (f), respectively; by revising paragraph (a); and by adding a new paragraph (c) to read as follows:

§ 232.0 Applicability and penalties.

(a) Except as provided in paragraphs (b) and (c) of this section, this part applies to all standard gage railroads.

(b) * * *

(c) Except for §§ 232.2 and 232.21 through 232.25, this part does not apply to a "passenger train" or "passenger equipment" as defined in § 238.5 of this chapter that is subject to part 238 of this chapter.

* * * * *

17. Part 238 is added to read as follows:

PART 238—PASSENGER EQUIPMENT SAFETY STANDARDS

Subpart A—General

- Sec.
- 238.1 Purpose and scope.
- 238.3 Application.
- 238.5 Definitions.
- 238.7 Waivers.
- 238.9 Responsibility for compliance.
- 238.11 Civil penalties.
- 238.13 Preemptive effect.
- 238.15 Movement of passenger equipment with power brake defects.
- 238.17 Movement of passenger equipment with other than power brake defects.
- 238.19 Reporting and tracking defective passenger equipment.
- 238.21 Special approval procedure.

Subpart B—System Safety and General Requirements

- 238.101 Scope.
- System Safety**
- 238.103 General system safety requirements.
- 238.105 Fire protection program.

- 238.107 Software safety program.
- 238.109 Inspection, testing, and maintenance program.
- 238.111 Training, qualification, and designation program.
- 238.113 Pre-revenue service acceptance testing plan.

General Requirements

- 238.115 Fire safety.
- 238.117 Protection against personal injury.
- 238.119 Rim-stamped straight-plate wheels.
- 238.121 Train system software and hardware.
- 238.123 Emergency lighting.

Subpart C—Specific Requirements for Tier I Passenger Equipment

- 238.201 Scope.
- 238.203 Static end strength.
- 238.205 Anti-climbing mechanism.
- 238.207 Link between coupling mechanism and car body.
- 238.209 Forward-facing end structure of locomotives.
- 238.211 Collision posts.
- 238.213 Corner posts.
- 238.215 Rollover strength.
- 238.217 Side impact strength.
- 238.219 Truck-to-car-body attachment.
- 238.221 Glazing.
- 238.223 Fuel tanks.
- 238.225 Electrical system.
- 238.227 Suspension system.
- 238.229 Safety appliances.
- 238.231 Brake system.
- 238.233 Interior fittings and surfaces.
- 238.235 Emergency window exits.
- 238.237 Doors.
- 238.239 Automated monitoring.

Subpart D—Inspection, Testing, and Maintenance Requirements for Tier I Passenger Equipment

- 238.301 Scope.
- 238.303 Exterior calendar day mechanical inspection of passenger cars and unpowered vehicles used in passenger trains.
- 238.305 Interior calendar day mechanical inspection of passenger cars.
- 238.307 Periodic mechanical inspection of passenger cars.
- 238.309 Periodic brake equipment maintenance.
- 238.311 Single car test.
- 238.313 Class I brake test.
- 238.315 Class IA brake test.
- 238.317 Class II brake test.
- 238.319 Running brake test.

Subpart E—Specific Requirements for Tier II Passenger Equipment

- 238.401 Scope.
- 238.403 Crash energy management requirements.
- 238.405 Longitudinal static compressive strength.
- 238.407 Anti-climbing mechanism.
- 238.409 Forward end structures of power car cabs.
- 238.411 Rear end structures of power car cabs.
- 238.413 End structures of trailer cars.
- 238.415 Rollover strength.

- 238.417 Side loads.
- 238.419 Truck-to-car-body and truck component attachment.
- 238.421 Glazing.
- 238.423 Fuel tanks.
- 238.425 Electrical system.
- 238.427 Suspension system.
- 238.429 Safety appliances.
- 238.431 Brake system.
- 238.433 Draft system.
- 238.435 Interior fittings and surfaces.
- 238.437 Emergency communication.
- 238.439 Emergency window exits and roof hatches.
- 238.441 Doors.
- 238.443 Headlights.
- 238.445 Automated monitoring.
- 238.447 Operator's controls and cab layout.

Subpart F—Inspection, Testing, and Maintenance Requirements for Tier II Passenger Equipment

- 238.501 Scope.
- 238.503 Inspection, testing, and maintenance requirements.
- 238.505 Program approval procedure.

Subpart G—Introduction of New Technology to Tier II Passenger Equipment

- 238.601 Scope.
- 238.603 Process to introduce new technology.

Appendix A to Part 238—Schedule of Civil Penalties [Reserved]

Appendix B to Part 238—Test Performance Criteria for the Flammability and Smoke Emission Characteristics of Materials Used in Constructing or Refurbishing Locomotive Cab and Passenger Car Interiors

Appendix C to Part 238—Suspension System Safety Performance Standards

Authority: 49 U.S.C. 20102–20103, 20133, 20141, 20301–20303, 20306, 20701–20702, 21301–21302, 21304; 49 CFR 1.49(c), (m).

Subpart A—General

§ 238.1 Purpose and scope.

- (a) The purpose of this part is to:
- (1) Prevent accidents involving railroad passenger equipment that cause damage to property, or injury or death to railroad employees, railroad passengers, or the general public; and
 - (2) Mitigate the consequences of accidents involving railroad passenger equipment, to the extent such accidents cannot be prevented.
- (b) This part prescribes minimum Federal safety standards for railroad passenger equipment. This part does not restrict a railroad from adopting and enforcing additional or more stringent requirements not inconsistent with this part.

§ 238.3 Application.

- (a) Except as provided in paragraph (c) of this section, this part applies to all:
- (1) Railroads that operate intercity or commuter passenger train service on standard gage track which is part of the

general railroad system of transportation;

(2) Railroads that provide commuter or other short-haul rail passenger train service in a metropolitan or suburban area as described by 49 U.S.C. 20102(1), including public authorities operating passenger train service; and

(3) Rapid transit operations in an urban area.

(b) Railroads that permit to be used or hauled on their lines passenger equipment subject to this part, in violation of a power brake provision of this part or a safety appliance provision of this part, are subject to the power brake and safety appliance provisions of this part with respect to such operations.

(c) This part does not apply to:

(1) Rapid transit operations in an urban area that are not connected with the general railroad system of transportation;

(2) Circus trains; or

(3) Tourist, scenic, historic, or excursion operations, whether on or off the general railroad system of transportation.

§ 238.5 Definitions.

As used in this part—

AAR means the Association of American Railroads.

Alerter means a device or system installed in the operator cab to promote continuous, active operator attentiveness by monitoring select operator-induced control activities. If fluctuation of a monitored operator control is not detected within a predetermined time, a sequence of audible and visual alarms is activated so as to progressively prompt a response by the operator. Failure by the operator to institute a change of state in a monitored control, or acknowledge the alerter alarm activity through a manual reset provision, results in a penalty brake application, bringing the locomotive or train to a stop.

Anti-climbing mechanism means a device at the ends of adjoining vehicles in a train that is designed to engage when subjected to large buff loads to prevent the override of the vehicles.

Bind means restrict the intended movement of one or more brake system components by reduced clearance, by obstruction, or by increased friction.

Block of cars means one car or multiple cars in a solid unit coupled together for the purpose of being added to, or removed from, a train as a solid unit.

Brake, air or power brake means a combination of devices operated by compressed air, arranged in a system, and controlled manually, electrically, or

pneumatically, by means of which the motion of a car or locomotive is retarded or arrested.

Brake control system means the components, including software, that either automatically or under the control of the engineer control the retarding force applied to the train by the brake system.

Brake, disc means a retardation system used on some rail vehicles, primarily passenger equipment, that utilizes flat metal discs as the braking surface instead of the wheel tread.

Brake, dynamic means a train braking system whereby the kinetic energy of a moving train is used to generate electric current at the locomotive traction motors, which is then dissipated through banks of resistor grids or back into the catenary or third rail system.

Brake, effective means a brake that is capable of producing its required design retarding force on the train.

Brake indicator means a device, actuated by brake cylinder pressure, which indicates whether brakes are applied or released.

Brake, inoperative means a primary brake that, for any reason, no longer applies or releases as intended or is otherwise ineffective.

Brake, on-tread friction means a braking system that uses a brake shoe that acts on the tread of the wheel to retard the vehicle.

Brake, parking or hand brake means a brake that can be applied and released by hand to prevent movement of a stationary car or locomotive.

Brake pipe means the system of piping (including branch pipes, angle cocks, cutout cocks, dirt collectors, hose, and hose couplings) used for connecting locomotives and all cars for the passage of air to control the locomotive and car brakes.

Brake, power means "air brake" as that term is defined in this section.

Brake, primary means those components of the train brake system necessary to stop the train within the signal spacing distance without thermal damage to friction braking surfaces.

Brake, secondary means those components of the train brake system which develop supplemental brake retarding force that is not needed to stop the train within signal spacing distances or to prevent thermal damage to wheels.

Brake shoes or pads aligned with tread or disc means that the surface of the brake shoe or pad, respectively, engages the surface of the wheel tread or disc, respectively, with no more than a ¼ inch overhang.

Braking system, blended means a braking system where the primary brake and one or more secondary brakes are

automatically combined to stop the train. If the secondary brakes are unavailable, the blended brake uses the primary brake alone to stop the train.

Calendar day means a time period starting at 12:01 am and ending at midnight on a given date.

Class I brake test means a complete passenger train brake system test (as further specified in § 238.313) performed by a qualified mechanical inspector to ensure that the air brake system is 100 percent effective.

Class IA brake test means a test and inspection (as further specified in § 238.315) of the air brake system on each car in a passenger train to ensure the air brake system is 100 percent effective.

Class II brake test means a test (as further specified in § 238.317) of brake pipe integrity and continuity from the controlling locomotive to the rear unit of a passenger train.

Collision posts means members of the end structures of a vehicle that project upward vertically from the underframe to which they are securely attached, and that provide protection of occupied compartments from an object penetrating the vehicle during a collision.

Control valves means that part of the air brake equipment on each car or locomotive that controls the charging, application, and release of the air brakes, in response to train line commands.

Corner posts means structural members located at the intersection of the front or rear surface with the side surface of a vehicle and which extend vertically from the floor support structure to the roof support structure. Corner posts may be combined with collision posts to become part of the end structure.

Crack means a fracture without complete separation into parts, except that, in a casting, a shrinkage crack or hot tear that does not significantly diminish the strength of the member is not a crack.

Crash energy management means an approach to the design of rail passenger equipment which controls the dissipation of energy during a collision to protect the occupied volumes from crushing and to limit the decelerations on passengers and crewmembers in those volumes. This may be accomplished by designing energy-absorbing structures of low strength in the unoccupied volumes of a rail vehicle or passenger train to collapse in a controlled fashion, while providing higher structural strength in the occupied volumes. Energy deflection can also be part of a crash energy

management approach. Crash energy management can be used to help provide anti-climbing resistance and to reduce the risk of train buckling during a collision.

Crash refuge means a volume with extreme structural strength designed to maximize the survivability of crewmembers stationed in the locomotive cab during a collision.

Crewmember means a railroad employee called to perform service covered by 49 U.S.C. 21103 and subject to the railroad's operating rules and program of operational tests and inspections required in §§ 217.9 and 217.11 of this chapter.

Critical buckling stress means minimum stress necessary to initiate buckling of a structural member.

Emergency application means an irretrievable brake application resulting in the maximum retarding force available from the train brake system.

End structure means the main support structure projecting upward from the floor or underframe of a locomotive, passenger car, or other rail vehicle. The end structure is securely attached to the underframe at each end of a rail vehicle.

Foul means restrict the intended movement of one or more brake system components because the component is snagged, entangled, or twisted.

Fuel tank, integral means a fuel containment volume that is integral with some other structural element of the locomotive not designed solely as a fuel container.

Full-height collision post, corner post, or side frame post means any vertical framing member in the car body structure that spans the distance between the underframe and the roof at the car body section where the post is located. For collision posts located at the approximate third points of an end frame, the term "full-height" applies to posts that extend and connect to supporting structural members in the roof at the location of the posts, or to a beam connected to the tops of the end-frame and supported by the roof rails (or anti-telescoping plate), or to both.

Full service application means a brake application which results in a brake cylinder pressure at the service limiting valve setting or equivalent.

Glazing, end-facing means a glazing panel located where a line perpendicular to the exterior surface of the panel makes an angle of 50 degrees or less with the longitudinal center line of the rail vehicle in which the panel is installed. A glazing panel that curves so as to meet the definition for both side-facing and end-facing glazing is end-facing glazing.

Glazing, exterior means a glazing panel that is an integral part of the exterior skin of a rail vehicle with a surface exposed to the outside environment.

Glazing frame means the arrangement used to install the glazing into the structure of a rail vehicle.

Glazing, interior means a glazing panel with no surface exposed to the outside environment and which is protected from projectiles by the structure of a rail vehicle.

Glazing, side-facing means a glazing panel located where a line perpendicular to the exterior surface of the panel makes an angle of more than 50 degrees with the longitudinal center line of the rail vehicle in which the panel is installed.

Handrails means safety appliances installed on either side of a rail vehicle's exterior doors to assist passengers and crew to safely board and depart the vehicle.

Head end power means power generated on board the locomotive of a passenger train used for purposes other than propelling the train, such as cooking, heating, illumination, ventilation and air conditioning.

Hunting oscillations means, for purposes of Tier I equipment, lateral oscillations of trucks that could lead to a dangerous instability and, for purposes of Tier II equipment, truck frame lateral oscillations exceeding 0.8g peak-to-peak for six or more consecutive oscillations.

In passenger service, when used in connection with passenger equipment, means passenger equipment subject to this part that is carrying, or available to carry, fare-paying passengers.

In service, when used in connection with passenger equipment, means:

- (1) Passenger equipment subject to this part that is in passenger service; and
- (2) All other passenger equipment subject to this part, unless the passenger equipment:
 - (i) Is being handled in accordance with §§ 238.15, 238.17, 238.305(c)(5), or 238.503(f), as applicable;
 - (ii) Is in a repair shop or on a repair track;
 - (iii) Is on a storage track and is not carrying passengers; or
 - (iv) Has been delivered in interchange but has not been accepted by the receiving railroad.

Interior fitting means any auxiliary component in the passenger compartment which is mounted to the floor, ceiling, sidewalls, or end walls and projects into the passenger compartment from the surface or surfaces to which it is mounted. Interior

fittings do not include side and end walls, floors, door pockets, or ceiling lining materials, for example.

Lateral means the horizontal direction perpendicular to the direction of travel of a rail vehicle.

Locomotive means a piece of on-track equipment, other than hi-rail, specialized maintenance, or other similar equipment, which may consist of one or more units operated from a single control stand with one or more propelling motors designed for moving other equipment; with one or more propelling motors designed to transport freight or passenger traffic or both; or without propelling motors but with one or more control stands. This term does not include a locomotive propelled by steam power unless it is used to haul an intercity or commuter passenger train.

Locomotive cab means a compartment or space on board a locomotive where the control stand is located and which is normally occupied by the engineer when the locomotive is being operated.

Locomotive, cab car means a unit of rolling equipment intended to provide transportation for members of the general public that is without propelling motors but with one or more control stands.

Locomotive, controlling means the locomotive from which the engineer exercises control over the train.

Locomotive, MU means a unit of rolling equipment self-propelled by any power source, other than steam, and intended to provide transportation for members of the general public.

Longitudinal means in a direction parallel to the normal direction of travel of a rail vehicle.

Luminescent material means a material that absorbs light energy when ambient levels of light are high and emits this stored energy when ambient levels of light are low, making the material appear to glow in the dark.

L/V ratio means the lateral force that the flange of a vehicle's wheel exerts on the rail, divided by the vertical force that the tread of the same wheel exerts on the rail.

MIL-STD-882C means a military standard issued by the United States Department of Defense to provide uniform requirements for developing and implementing a system safety program to identify and then eliminate the hazards of a system or reduce the associated risk to an acceptable level.

Occupied volume means the spaces of a rail vehicle or passenger train where passengers or crewmembers are normally located during service operation, such as the operating cab and passenger seating and sleeping areas. Vestibules are typically not considered

occupied, except when in use as a control cab.

Ordered or date ordered means the date on which notice to proceed is given by a procuring railroad to a contractor or supplier for new equipment.

Override means to climb over the normal coupling or side buffers and linking mechanism and impact the end of the adjoining rail vehicle or unit above the underframe.

Passenger car means a unit of rail rolling equipment intended to provide transportation for members of the general public and includes a self-propelled car designed to carry passengers, baggage, mail, or express. This term includes a passenger coach, cab car, and an MU locomotive. This term does not include a private car.

Passenger coach means a unit of rail rolling equipment intended to provide transportation for members of the general public that is without propelling motors and without a control stand.

Passenger equipment means all powered and unpowered passenger cars, locomotives used to haul a passenger car, and any other unit of rail rolling equipment hauled in a train with one or more passenger cars. Passenger equipment includes a—

- (1) Passenger coach,
- (2) Cab car,
- (3) MU locomotive,
- (4) Private car,
- (5) Locomotive not intended to provide transportation for a member of the general public that is used to power a passenger train, and
- (6) Any non-self-propelled vehicle hauled in a passenger train, including a freight car.

Passenger station means a location designated in a railroad's timetable where passengers are regularly scheduled to get on or off any train.

Permanent deformation means the undergoing of a permanent change in shape of a structural member of a rail vehicle.

Piston travel means the amount of linear movement of the air brake hollow rod (or equivalent) or piston rod when forced outward by movement of the piston in the brake cylinder or actuator and limited by the brake shoes being forced against the wheel or disc.

Power car means a rail vehicle that propels a Tier II passenger train or is the lead vehicle in a Tier II passenger train, or both.

Pre-revenue service acceptance testing plan means a document, as further specified in § 238.113, prepared by a railroad that explains in detail how pre-revenue service tests of certain passenger equipment demonstrate that the equipment meets Federal safety

standards and the railroad's own safety design requirements.

Private car means historical or antiquated rail rolling equipment that is used only for excursion, recreational, or private transportation businesses. A private car is not a passenger car.

Qualified mechanical inspector means a qualified person who has received, as a part of the training, qualification, and designation program required under § 238.111, instruction and training that includes "hands-on" experience (under appropriate supervision or apprenticeship) in one or more of the following functions: troubleshooting, inspection, testing, and maintenance or repair of the specific train brake and other components and systems for which the inspector is assigned responsibility. Further, the mechanical inspector shall be a person whose primary responsibility includes work generally consistent with the above-referenced functions and is designated to—

- (1) Conduct Class I brake tests under this part;
- (2) Inspect MU locomotives or other passenger cars for compliance with this part; or
- (3) Determine whether equipment not in compliance with this part may be moved safely and, if so, under what conditions.

Qualified person means a person determined by a railroad to have the knowledge and skills necessary to perform one or more functions required under this part. The railroad determines the qualifications and competencies for employees designated to perform various functions in the manner set forth in this part.

Railroad means any form of non-highway ground transportation that runs on rails or electromagnetic guideways, including:

- (1) Commuter or short-haul rail passenger service in a metropolitan or suburban area and commuter railroad service that was operated by the Consolidated Rail Corporation on January 1, 1979; and

- (2) High speed ground transportation systems that connect metropolitan areas, without regard to whether those systems use new technologies not associated with traditional railroads. The term "railroad" is also intended to mean a person that provides railroad transportation, whether directly or by contracting out operation of the railroad to another person. The term does not include rapid transit operations in an urban area that are not connected to the general railroad system of transportation.

Rebuilt means equipment undergoing overhaul identified by the railroad as a capital expense under the Surface Transportation Board's accounting standards.

Refresher training means periodic retraining required by a railroad for employees or contractors to remain qualified to perform specific equipment inspection, testing, or maintenance functions.

Repair point means a location designated by a railroad where repairs of the type necessary occur on a regular basis. A repair point has, or should have, the facilities, tools, and qualified mechanical employees required to make the necessary repairs. A repair point need not be staffed continuously.

Respond as intended means to produce the result that a device or system is designed to produce.

Rollover strength means strength needed to protect the structural integrity of a rail vehicle in the event the vehicle leaves the track and impacts the ground on its side or roof.

Roof rail means the longitudinal structural member at the intersection of the side wall and the roof sheathing.

Running brake test means a test (as further specified in § 238.319) of a train system or component while the train is in motion to verify that the system or component functions as intended.

Safety appliance means an appliance required under 49 U.S.C. chapter 203, excluding power brakes. The term includes automatic couplers, hand brakes, sill steps, handholds, handrails, or ladder treads made of steel or a material of equal or greater mechanical strength used by the traveling public or railroad employees that provides a means for safely coupling, uncoupling, or ascending or descending passenger equipment.

Safety-critical component or system means a component or system that, if not available, increases the risk of damage to equipment or injury to a passenger, crewmember, or other person.

Safety-critical task means a task that, if not performed correctly, increases the risk of damage to equipment or injury to a passenger, crewmember, or other person.

Safety inspection criteria means a measurement limit or observation threshold used to trigger the duty under this part to take corrective action to prevent a serious safety problem from developing. Measurements may be taken manually or by reliable sensors.

Semi-permanently coupled means coupled by means of a drawbar or other coupling mechanism that requires tools to perform the uncoupling operation.

Coupling and uncoupling of each such unit in a train can be performed safely only while at a maintenance or shop location where personnel can safely get under a unit or between units.

Shear strength means the ability of a structural member to resist forces or components of forces acting perpendicular to compression or tension forces, or both, in the member.

Shock absorbent material means material designed to prevent or mitigate injuries due to impact by yielding and absorbing much of the energy of impact.

Side posts means main vertical structural elements in the sides of a rail vehicle.

Side sills means that portion of the underframe or side at the bottom of the rail vehicle side wall.

Single car test means a comprehensive test (as further specified in § 238.311) of the functioning of all critical brake system components installed on an individual passenger car or unpowered vehicle, other than a passenger car, hauled in a passenger train.

Single car test device means a device capable of controlling the application and release of the brakes on an individual passenger car or an unpowered vehicle, other than a passenger car, hauled in a passenger train through pneumatic or electrical means.

Skin means the outer covering on a fuel tank or the front of a locomotive, including a cab car and an MU locomotive, excluding the windows and forward-facing doors. The skin may be covered with another coating of a material such as fiberglass.

Spall, glazing means small pieces of glazing that fly off the back surface of glazing when an object strikes the front surface.

Spot checks means random checks of train inspections, tests, or maintenance operations conducted by qualified supervisors.

Standard procedures means a description of the step-by-step process to be used to safely accomplish a safety-critical or potentially hazardous task.

System means a composite of equipment, computer programs, people, facilities, procedures, and documentation which are integrated to perform a specific operational function in a specific environment.

System developer means the entity responsible for developing equipment or a system so that it may be approved for use in service.

System safety means the application of design, operating, technical, and management techniques and principles throughout the system's life cycle to

reduce hazards and unsafe conditions to the lowest level possible through the most effective use of the available resources.

System safety plan means a document that states in detail the techniques, procedures, and tests to follow to reduce hazards and unsafe conditions to the lowest level possible through the most effective use of available resources. The system safety plan is used as part of the design process for new equipment to ensure that the equipment meets all Federal safety standards and the railroad's own safety requirements.

System safety program means the activities described in the system safety plan to be performed to ensure that the railroad's passenger equipment meets all Federal safety standards and the railroad's own safety design requirements.

Telescope means override an adjoining rail vehicle or unit and penetrate into the interior of that adjoining vehicle or unit because of compressive forces.

Terminal means a starting point or ending point of a single scheduled train trip, where passengers may get on or off a train. Normally the location is a point where the train would reverse direction or change destinations.

Tier I means operating at speeds not exceeding 125 mph.

Tier II means operating at speeds exceeding 125 mph but not exceeding 150 mph.

Tourist, scenic, historic, or excursion operations are railroad operations that carry passengers, often using antiquated equipment, with the conveyance of the passengers to a particular destination not being the principal purpose.

Trailer car means a unit of rail rolling equipment that neither propels a Tier II passenger train nor is the leading unit in a Tier II passenger train. A trailer car is normally without a control stand and is normally occupied by passengers.

Train means a locomotive unit or locomotive units coupled, with or without cars. For the purposes of the provisions of this part related to power brakes, the term "train" does not include such equipment when being used in switching movements (as defined in § 231.30(b) of this chapter) of less than one mile.

Train brake communication line means the communication link between the locomotive and cars in a train by which the brake commands are transmitted. This may be a pneumatic pipe, electrical line, or radio signal.

Train, commuter means a passenger train providing commuter service within an urban, suburban, or metropolitan area. The term includes a

passenger train provided by an instrumentality of a State or a political subdivision of a State.

Train, long-distance intercity passenger means a passenger train that provides service between large cities more than 125 miles apart and is not operated exclusively in the National Railroad Passenger Corporation's Northeast Corridor.

Train, passenger means a train that transports or is available to transport members of the general public. If a train is composed of a mixture of passenger and freight equipment, that train is a passenger train for purposes of this part.

Train, short-distance intercity passenger means a passenger train that provides service exclusively on the National Railroad Passenger Corporation's Northeast Corridor or between cities that are not more than 125 miles apart.

Train, Tier II passenger means a short-distance or long-distance intercity passenger train providing service at speeds that include exceeding 125 mph but do not exceed 150 mph.

Trainset, passenger means a passenger train including the locomotive(s) or power car(s) and passenger cars that are semi-permanently coupled to operate as a single unit. The individual components are uncoupled only for emergencies or maintenance.

Transverse means in a direction perpendicular to the normal direction of travel of a railroad vehicle.

Ultimate strength means the load at which a structural member fractures or ceases to resist any load.

Uncoupling mechanism means the arrangement for operating the coupler by any means.

Underframe means the lower horizontal support structure of a car body.

Unit means rail rolling equipment of any type or, in the context of articulated equipment, "unit" means a piece of equipment located between two trucks.

Unit body (monocoque) design or unistructure means a type of vehicle construction where the shell or skin acts as a single unit with the supporting frame to resist and transmit the loads acting on the vehicle.

Unoccupied volume means the spaces of a rail vehicle or passenger train which do not contain seating and are not normally occupied by passengers or crewmembers.

Vehicle, rail means a car, locomotive, tender, or similar vehicle.

Vestibule means an area of a passenger car that normally does not contain seating, that leads from the seating area to the side exit doors.

Witness plate means a thin foil placed behind a piece of glazing undergoing an impact test. Any material spalled or broken from the back side of the glazing will dent or mark the witness plate.

Yard means a system of tracks within defined limits provided for the making up of trains, storing of cars, and other purposes.

Yard air test means a train brake system test conducted using a source of compressed air other than a locomotive.

Yield strength means the ability of a structural member to resist a change in length caused by a heavy load. Exceeding the yield strength may cause permanent deformation of the member.

§ 238.7 Waivers.

(a) Any person may petition the Federal Railroad Administration for a waiver of compliance with any requirement prescribed in this part.

(b) Each petition for a waiver under this section shall:

(1) Be filed in the manner required by part 211 of this chapter;

(2) Contain the information required by part 211 of this chapter; and

(3) Provide appropriate data or analysis, or both, establishing that a waiver is warranted under applicable statutory criteria as well as a description of the measures proposed to be taken to provide a level of safety equivalent to that afforded by the provision of this part that is sought to be waived.

§ 238.9 Responsibility for compliance.

(a) A railroad subject to this part shall not—

(1) Use, haul, permit to be used or hauled on its line, offer in interchange, or accept in interchange any train or passenger equipment, while in service,

(i) That has one or more conditions not in compliance with a safety appliance or power brake provision of this part; or

(ii) That has not been inspected and tested as required by a safety appliance or power brake provision of this part; or

(2) Use, haul, offer in interchange, or accept in interchange any train or passenger equipment, while in service,

(i) That has one or more conditions not in compliance with a provision of this part, other than the safety appliance and power brake provisions of this part, if the railroad has actual knowledge of the facts giving rise to the violation, or a reasonable person acting in the circumstances and exercising reasonable care would have that knowledge; or

(ii) That has not been inspected and tested as required by a provision of this part, other than the safety appliance and power brake provisions of this part, if the railroad has actual knowledge of the

facts giving rise to the violation, or a reasonable person acting in the circumstances and exercising reasonable care would have that knowledge; or

(3) Violate any other provision of this part.

(b) For purposes of this part, passenger equipment will be considered in use prior to departure but after it has received, or should have received, the inspection required under this part for movement and is deemed ready for service.

(c) Although many of the requirements of this part are stated in terms of the duties of a railroad, when any person (including, but not limited to, a contractor performing safety-related tasks under contract to a railroad subject to this part) performs any function required by this part, that person (whether or not a railroad) is required to perform that function in accordance with this part.

§ 238.11 Civil penalties.

Any person (including but not limited to a railroad; any manager, supervisor, official, or other employee or agent of a railroad; any owner, manufacturer, lessor, or lessee of railroad equipment, track, or facilities; any employee of such owner, manufacturer, lessor, lessee, or independent contractor) who violates any requirement of this part or causes the violation of any such requirement is subject to a civil penalty of at least \$500, but not more than \$10,000 per violation, except that: Penalties may be assessed against individuals only for willful violations, and, where a grossly negligent violation or a pattern of repeated violations has created an imminent hazard of death or injury to persons, or has caused death or injury, a penalty not to exceed \$20,000 per violation may be assessed. Each day a violation continues shall constitute a separate offense. Appendix A to this part contains a schedule of civil penalty amounts used in connection with this part.

§ 238.13 Preemptive effect.

Under 49 U.S.C. 20106, issuance of the regulations in this part preempts any State law, rule, regulation, order, or standard covering the same subject matter, except for a provision directed at an essentially local safety hazard if that provision is consistent with this part and does not impose an undue burden on interstate commerce.

§ 238.15 Movement of passenger equipment with power brake defects.

(a) **General.** This section contains the requirements for moving passenger equipment with a power brake defect

without liability for a civil penalty under this part. Railroads remain liable for the movement of passenger equipment under 49 U.S.C. 20303(c). For purposes of this section, § 238.17, and § 238.503, a "power brake defect" is a condition of a power brake component, or other primary brake component, that does not conform with this part. (Passenger cars and other passenger equipment classified as locomotives under part 229 of this chapter are also covered by the movement restrictions contained in § 229.9 of this chapter for those defective conditions covered by part 229 of this chapter.)

(b) *Limitations on movement of passenger equipment containing a power brake defect found during a Class I or IA brake test.* Except as provided in paragraph (c) of this section (dealing with brakes that become defective en route after a Class I or IA brake test was performed), a commuter or passenger train that has in its consist passenger equipment containing a power brake defect found during a Class I or IA brake test (or, for Tier II trains, the equivalent) may only be moved, without civil penalty liability under this part—

(1) If all of the following conditions are met:

- (i) The train is moved for purposes of repair, without passengers;
- (ii) The applicable operating restrictions in paragraph (d) of this section are observed; and
- (iii) The passenger equipment is tagged, or information is recorded, as prescribed in paragraph (c)(2) of this section; or

(2) If the train is moved for purposes of scrapping or sale of the passenger equipment that has the power brake defect, and without passengers; if the movement is at a speed of 15 mph or less; and if the movement conforms with the railroad's air brake or power brake instructions.

(c) *Limitations on movement of passenger equipment in passenger service that becomes defective en route after a Class I or IA brake test.* Passenger equipment hauled or used in service in a commuter or passenger train that develops a power brake defect while en route to another location after receiving a Class I or IA brake test (or, for Tier II trains, the equivalent) may be hauled or used by a railroad for repair, without civil penalty liability under this part, if the applicable operating restrictions set forth in paragraph (d) of this section are complied with and all of the following requisites are satisfied:

(1) *En route defect.* At the time of the train's Class I or IA brake test, the passenger equipment in the train was

properly equipped with power brakes that comply with this part. The power brakes on the passenger equipment become defective while it is en route to another location.

(2) *Record.* At the place where the railroad first discovers the defect, a tag or card is placed on both sides of the defective passenger equipment, or an automated tracking system is provided, with the following information about the defective passenger equipment:

- (i) The reporting mark and car or locomotive number;
- (ii) The name of the inspecting railroad;
- (iii) The name of the inspector;
- (iv) The inspection location and date;
- (v) The nature of each defect;
- (vi) The destination of the equipment where it will be repaired; and
- (vii) The signature, if possible, and job title of the person reporting the defective condition.

(3) *Conditional requirement.* In addition, if an en route failure causes power brakes to be cut out on passenger equipment, the railroad shall:

- (i) Determine the percentage of operative power brakes in the train based on the number of brakes known to be cut out or otherwise inoperative, using the formula specified in paragraph (d)(1) of this section;

- (ii) Notify the dispatcher of the percent of operative brakes and movement restrictions on the train imposed by paragraph (d) of this section;

- (iii) Notify the mechanical department or desk of the failure; and
- (iv) Confirm the percentage of operative brakes by a walking inspection at the next location where the railroad reasonably judges that it is safe to do so.

(d) *Operating restrictions based on percent operative power brakes in train.*

(1) *Computation of percent operative power brakes.*—(i) Except as specified in paragraphs (d)(1) (ii) and (iii) of this section, the percentage of operative power brakes in a train shall be determined by dividing the number of axles in the train with operative power brakes by the total number of axles in the train.

(ii) For equipment with tread brake units (TBUs), the percentage of operative power brakes shall be determined by dividing the number of operative TBUs by the total number of TBUs.

(iii) Each cut-out axle on a locomotive that weighs more than 200,000 pounds shall be counted as two cut-out axles for the purposes of calculating the percentage of operative brakes. Unless otherwise specified by the railroad, the

friction braking effort over all other axles shall be considered uniform.

(iv) The following brake conditions not in compliance with this part are not considered inoperative power brakes for purposes of this section:

(A) Failure or cutting out of secondary brake systems;

(B) Inoperative or otherwise defective handbrakes or parking brakes;

(C) Excessive piston travel that does not render the power brakes ineffective; and

(D) Power brakes overdue for inspection, testing, maintenance, or stencilling under this part.

(2) *All passenger trains developing 50–74 percent operative power brakes.*

A passenger train that develops inoperative power brake equipment resulting in at least 50 percent but less than 75 percent operative power brakes may be used only as follows:

(i) The train may be moved in passenger service only to the next forward passenger station;

(ii) The speed of the train shall be restricted to 20 mph or less;

(iii) After all passengers are discharged, the defective equipment shall be moved directly to the nearest location where the necessary repairs can be made; and

(iv) If the power brakes on the front or rear unit in the train are inoperative, a qualified person shall be stationed at the handbrake on this unit.

(3) *Commuter, short-distance intercity, and short-distance Tier II passenger trains developing 75–99 percent operative power brakes.*

(i) *75–84 percent operative brakes.* Commuter, short-distance intercity, and short-distance Tier II passenger trains which develop inoperative power brake equipment resulting in at least 75 percent but less than 85 percent operative brakes may be used only as follows:

(A) The train may be moved in passenger service only to the next forward terminal;

(B) The speed of the train shall be restricted to 50 percent of the train's maximum allowable speed or 40 mph, whichever is less;

(C) After discharging passengers, the defective equipment shall be moved directly to the nearest location where the necessary repairs can be made; and

(D) If the brakes on the front or rear unit in a train are inoperative, a qualified person shall be stationed at the handbrake on this unit.

(ii) *85–99 percent operative brakes.* Commuter, short-distance intercity, and short-distance Tier II passenger trains which develop inoperative power brake equipment resulting in at least 85

percent but less than 100 percent operative brakes may only be used as follows:

(A) The train may be moved in passenger service only to the next forward terminal;

(B) After all passengers are discharged, the defective cars shall be moved directly to the nearest location where the necessary repairs can be made; and

(C) If the brakes on the front or rear unit in a train are inoperative, a qualified person shall be stationed at the handbrake on this unit.

(4) *Long-distance intercity and long-distance Tier II passenger trains developing 75-99 percent operative power brakes.*

(i) *75-84 percent operative brakes.* Long-distance intercity and long-distance Tier II passenger trains which develop inoperative power brake equipment resulting in at least 75 percent but less than 85 percent operative brakes may be used only if all of the following restrictions are observed:

(A) The train may be moved in passenger service only to the next forward repair location identified for repair of that equipment by the railroad operating the equipment in the list required by § 238.19(d); however, if the next forward repair location does not have the facilities to handle the safe unloading of passengers, the train may be moved past the designated repair location in service only to the next forward passenger station in order to facilitate the unloading of passengers;

(B) The speed of the train shall be restricted to 50 percent of the train's maximum allowable speed or 40 mph, whichever is less;

(C) After discharging passengers, the defective equipment shall be moved directly to the nearest location where the necessary repairs can be made; and

(D) If the brakes on the front or rear unit in a train are inoperative, a qualified person shall be stationed at the handbrake on this unit.

(ii) *85-99 percent operative brakes.* Long-distance intercity and long-distance Tier II passenger trains which develop inoperative power brake equipment resulting in at least 85 percent but less than 100 percent operative brakes may be used only if all of the following restrictions are observed:

(A) The train may be moved in passenger service only to the next forward repair location identified for repair of that equipment by the railroad operating the equipment in the list required by § 238.19(d); however, if the next forward repair location does not

have the facilities to handle the safe unloading of passengers, the train may be moved past the designated repair location in service only to the next forward passenger station in order to facilitate the unloading of passengers;

(B) After passengers are discharged, the defective cars shall be moved directly to the nearest location where the necessary repairs can be made; and

(C) If the brakes on the front or rear unit in a train are inoperative, a qualified person shall be stationed at the handbrake on this unit.

(e) *Special Notice for Repair.* Nothing in this section authorizes the movement of passenger equipment subject to a Special Notice for Repair under part 216 of this chapter unless the movement is made in accordance with the restrictions contained in the Special Notice.

§ 238.17 Movement of passenger equipment with other than power brake defects.

(a) *General.* This section contains the requirements for moving passenger equipment with other than a power brake defect. (Passenger cars and other passenger equipment classified as locomotives under part 229 of this chapter are also covered by the movement restrictions contained in § 229.9 of this chapter for those defective conditions covered by part 229 of this chapter.)

(b) *Limitations on movement of passenger equipment containing defects found at time of calendar day inspection.* Except as provided in § 238.305(c)(5), passenger equipment containing a condition not in conformance with this part at the time of its calendar day mechanical inspection may be moved from that location for repair if all of the following conditions are satisfied:

(1) When the defective equipment is moved, it is not in passenger service and is in a non-revenue train;

(2) The requirements of paragraphs (c)(2) and (c)(3) of this section are met;

(3) The special requirements of paragraph (d) of this section, if applicable, are met.

(c) *Usual limitations on movement of passenger equipment that develops defects en route.* Except as provided in § 238.503(f), passenger equipment that develops en route to its destination, after its calendar day inspection was performed and before its next calendar day mechanical inspection was performed, any defect not in compliance with this part, other than a power brake defect, may be moved only if the railroad complies with all of the following requirements and, if

applicable, the special requirements in paragraph (d) of this section:

(1) Prior to movement of the defective equipment, a qualified mechanical inspector shall determine if it is safe to move the equipment in passenger service and, if so, the maximum speed and other restrictions necessary for safely conducting the movement. If appropriate, these determinations may be made based upon a description of the defective condition provided by a crewmember.

(2) Prior to movement of the defective equipment, the qualified mechanical inspector shall notify the crewmember in charge of the movement of the defective equipment, who in turn shall inform all other crewmembers of the presence of the defective condition(s) and the maximum speed and other restrictions determined under paragraph (c)(1) of this section. The movement shall be made in conformance with such restrictions.

(3) The railroad shall maintain a record of all defects reported and their subsequent repair in the defect tracking system required in § 238.19. In addition, prior to movement of the defective equipment, a tag or card placed on both sides of the defective equipment, or an automated tracking system, shall record the following information about the defective equipment:

(i) The reporting mark and car or locomotive number;

(ii) The name of the inspecting railroad;

(iii) The name of the inspector, inspection location, and date;

(iv) The nature of each defect;

(v) Movement restrictions and safety restrictions, if any;

(vi) The destination of the equipment where it will be repaired; and

(vii) The signature, if possible, as well as the job title and location of the person making the determinations required by this section.

(4) At the first location possible, a qualified mechanical inspector shall perform a physical inspection of the defective equipment to verify the description of the defect provided by the crew. After a qualified mechanical inspector verifies that the defective equipment is safe to remain in service, the defective equipment that develops a condition not in compliance with this part while en route may continue in passenger service not later than the next calendar day mechanical inspection, if the requirements of this paragraph are otherwise fully met.

(d) *Special requisites for movement of passenger equipment with safety appliance defects.* Consistent with 49 U.S.C. 20303, passenger equipment with

a safety appliance not in compliance with this part or with part 231 of this chapter, if applicable, may be moved—

(1) If necessary to effect repair of the safety appliance;

(2) From the point where the safety appliance defect was first discovered by the railroad to the nearest available location on the railroad where the necessary repairs required to bring the passenger equipment into compliance can be made or, at the option of the receiving railroad, the equipment may be received and hauled for repair to a point on the receiving railroad's line no farther than the point on the delivering railroad's line where the repair of the defect could have been made; and

(3) If a tag placed on both sides of the passenger equipment or an automated tracking system contains the information required under paragraph (c)(3) of this section.

(e) *Special Notice for Repair.* Nothing in this section authorizes the movement of equipment subject to a Special Notice for Repair under part 216 of this chapter unless the movement is made in accordance with the restrictions contained in the Special Notice.

§ 238.19 Reporting and tracking defective passenger equipment.

(a) *General.* Each railroad shall have in place a reporting and tracking system for passenger equipment with a defect not in conformance with this part that:

(1) Records the identification number of the defective equipment;

(2) Records the date the defect occurred;

(3) Records the nature of the defect;

(4) Records the determination made by a qualified mechanical inspector on whether the equipment is safe to run;

(5) Records the name of the qualified mechanical inspector making such a determination;

(6) Records any operating restrictions placed on the equipment; and

(7) Records repairs made and the date that they were made.

(b) *Retention of records.* At a minimum, each railroad shall keep the records described in paragraph (a) of this section for one periodic maintenance interval for each specific type of equipment as described in the railroad's system safety plan. FRA strongly encourages railroads to keep these records for longer periods of time because they form the basis for future reliability-driven decisions concerning test and maintenance intervals.

(c) *Availability of records.* Railroads shall make defect reporting and tracking records available to FRA upon request.

(d) *List of power brake repair points.* Railroads operating long-distance

intercity and long-distance Tier II passenger equipment shall designate locations, in writing, where repairs to passenger equipment with a power brake defect will be made and shall provide the list to FRA's Associate Administrator for Safety and make it available to FRA for inspection and copying upon request. Railroads operating these trains shall designate a sufficient number of repair locations to ensure the safe and timely repair of passenger equipment. These designations shall not be changed without at least 30 days' written notice to FRA's Associate Administrator for Safety.

§ 238.21 Special approval procedure.

(a) *General.* The following procedures govern consideration and action upon requests for special approval of alternative standards under §§ 238.115, 238.223, 238.309, 238.311, 238.405, or 238.427 and for special approval of pre-revenue service acceptance testing plans under § 238.113 or § 238.603. (Requests for approval of programs for the inspection, testing, and maintenance of Tier II passenger equipment are governed by § 238.505.)

(b) *Petitions for special approval of alternative standard.* Each petition for special approval of an alternative standard shall contain—

(1) The name, title, address, and telephone number of the primary person to be contacted with regard to review of the petition;

(2) The alternative proposed, in detail, to be substituted for the particular requirements of this part;

(3) Appropriate data or analysis, or both, establishing that the alternative will provide an equivalent level of safety; and

(4) A statement affirming that the railroad has served a copy of the petition on designated representatives of railroad employees, together with a list of the names and addresses of the persons served.

(c) *Petitions for special approval of pre-revenue service acceptance testing plan.* Each petition for special approval of a pre-revenue service acceptance testing plan shall contain—

(1) The name, title, address, and telephone number of the primary person to be contacted with regard to review of the petition; and

(2) The elements prescribed in § 238.113.

(d) *Service.* (1) Each petition for special approval under paragraph (b) or (c) of this section shall be submitted in triplicate to the Associate Administrator for Safety, Federal Railroad

Administration, 400 7th Street, S.W., Washington, D.C. 20590.

(2)(i) Service of each petition for special approval of an alternative standard under paragraph (b) of this section shall be made on the following:

(A) Designated employee representatives responsible for the equipment's operation, inspection, testing, and maintenance under this part;

(B) Any organizations or bodies that either issued the standard incorporated in the section(s) of this part to which the special approval pertains or issued the alternative standard that is proposed in the petition; and

(C) Any other person who has filed with FRA a current statement of interest in reviewing special approvals under the particular requirement of this part at least 30 days but not more than 5 years prior to the filing of the petition.

(ii) If filed, a statement of interest shall be filed with FRA's Associate Administrator for Safety and shall reference the specific section(s) of this part in which the person has an interest.

(e) *Federal Register notice.* FRA will publish a notice in the *Federal Register* concerning each petition under paragraph (b) of this section.

(f) *Comment.* Not later than 30 days from the date of publication of the notice in the *Federal Register* concerning a petition under paragraph (b) of this section, any person may comment on the petition.

(1) Each comment shall set forth specifically the basis upon which it is made, and contain a concise statement of the interest of the commenter in the proceeding.

(2) Three copies of each comment shall be submitted to the Associate Administrator for Safety, Federal Railroad Administration, 400 7th Street, S.W., Washington, D.C. 20590.

(3) The commenter shall certify that a copy of the comment was served on each petitioner.

(g) *Disposition of petitions.* (1) If FRA finds that the petition complies with the requirements of this section and that the proposed plan is acceptable or changes are justified, the petition will be granted, normally within 90 days of its receipt. If the petition is neither granted nor denied within 90 days, the petition remains pending for decision. FRA may attach special conditions to the approval of the petition. Following the approval of a petition, FRA may reopen consideration of the petition for cause stated.

(2) If FRA finds that the petition does not comply with the requirements of this section and that the proposed plan is not acceptable or that the proposed

changes are not justified, the petition will be denied, normally within 90 days of its receipt.

(3) When FRA grants or denies a petition, or reopens consideration of the petition, written notice is sent to the petitioner and other interested parties.

Subpart B—System Safety and General Requirements

§ 238.101 Scope.

This subpart contains system safety requirements for each railroad that operates passenger equipment and general requirements for the safety of all railroad passenger equipment subject to this part.

System Safety

§ 238.103 General system safety requirements.

(a) By the dates specified in paragraph (g) of this section, each railroad operating passenger equipment subject to this part shall adopt a written system safety plan that describes the railroad's system safety program, using MIL-STD-882(C) as a guide. The system safety plan shall be updated annually.

(b) For the procurement of new passenger equipment, the system safety plan shall describe the system safety program to be conducted as part of the equipment design and development process to ensure that all safety issues and Federal safety requirements are identified, addressed, and documented. The documentation shall include certification in writing by the manufacturer that the passenger equipment meets the design requirements of this part. The system safety plan shall also describe the system safety program to be conducted as part of the maintenance, overhaul, and operation of all passenger equipment by that railroad. The system safety program should ensure that safety issues are considered as important as cost and performance issues in the design, development, maintenance, overhaul, and operation of the equipment.

(c) The system safety plan shall be the principal safety document. It shall be used as guidance or, as applicable, requirements for the development and operation of equipment and subsystems. At a minimum, the system safety plan shall address:

- (1) Fire protection;
- (2) Software safety;
- (3) Inspection, testing, and maintenance;
- (4) Training and qualifications; and
- (5) Pre-revenue service acceptance testing.

(d) The system safety plan shall describe the approaches and processes to be used to:

- (1) Identify all safety requirements, including Federal requirements governing the design of passenger equipment and its supporting systems;
 - (2) Evaluate the total system, including hardware, software, testing, and support activities, to identify known or potential safety hazards over the life cycle of the equipment;
 - (3) Identify safety issues during design reviews;
 - (4) Eliminate or reduce the risk posed by the hazards identified;
 - (5) Monitor and track the progress made toward resolving safety issues, reducing hazards, and meeting safety requirements; and
 - (6) Develop a program of testing or analysis, or both, to demonstrate that safety requirements have been met.
- (e) As part of the system safety program, adequate documentation shall be maintained to audit how the design and operation of new equipment meets safety requirements and to track how safety issues are raised and resolved.
- (f) The system safety plan shall address how operational limitations may be imposed on the use of equipment if the equipment design cannot meet certain safety requirements.

(g) *Dates.* (1) The portion of the system safety plan applicable to existing passenger equipment shall be adopted no later than [one year after the effective date of the final rule].

(2) The portion of the system safety plan applicable to passenger equipment to be procured by the railroad that is already in the design and development process before the effective date of the final rule shall be adopted no later than [one year after the effective date of the final rule].

(3) The portion of the system safety plan applicable to passenger equipment to be procured by the railroad that is not yet in the design and development process on [the effective date of the final rule] shall be adopted before commencing the design and development of new equipment.

(h) The railroad's system safety plan and documentation required by paragraph (e) of this section shall be available for inspection and copying by FRA.

§ 238.105 Fire protection program.

(a) The operating railroad shall include in its system safety program fire safety considerations and features in the design of new passenger equipment that reduce the risk of equipment damage and personal injuries due to fires to an acceptable level as defined in MIL-STD-882(C).

(b) As part of the system safety program, each railroad operating passenger equipment subject to this part shall complete a thorough written analysis of the fire protection problem. In conducting this analysis, the railroad shall—

(1) Ensure that good fire protection practice is used as part of the equipment design process.

(2) Take effective steps to design equipment to be sufficiently fire resistant to detect a fire and allow the evacuation of equipment before fire, smoke, or toxic fumes cause injury to a passenger or crewmember.

(3) Identify, analyze, and prioritize the fire hazards inherent in the design of equipment.

(4) Document and explain how safety issues were resolved in relation to cost and performance issues in the design of equipment to minimize the risk of each fire hazard.

(5) Describe the analysis and tests necessary to demonstrate how the fire protection approach taken in the design of equipment will enable a train to meet the fire protection standards of this part and of the railroad's system safety plan.

(6) Describe the analysis and tests necessary to select materials which provide sufficient fire resistance to reasonably ensure adequate time to detect a fire and safely evacuate a train.

(7) Reasonably ensure that a ventilation system does not contribute to the lethality of a fire.

(8) Identify in writing which train components are at risk of being a source of fire and which require overheat protection. As prescribed in § 238.115(c), overheat detectors shall be installed in all components where the analysis determines that such equipment is necessary. If overheat protection is not provided for a component at risk of being a source of fire, the written rationale and justification for the decision shall be included as part of the system safety program documentation.

(9) Identify in writing all unoccupied train compartments that contain equipment or material posing a fire hazard, and analyze the benefit provided by including a fire or smoke detection system in each compartment identified. As prescribed in § 238.115(d), fire or smoke detectors shall be installed in unoccupied compartments where the analysis determines that such equipment is necessary to ensure sufficient time for the safe evacuation of a train. The written analysis shall explain why a fire or smoke detector is not necessary, if the decision is made not to install one in

any of the unoccupied compartments identified as a potential source of fire.

(10) Perform an analysis of the occupied and unoccupied spaces which require portable fire extinguishers. The analysis shall include the proper type and size of fire extinguisher for each location.

(11) Identify in writing all unoccupied train compartments that contain equipment or material which poses a fire hazard. On a case-by-case basis, the benefit provided by including a fixed, automatic fire-suppression system in each compartment identified shall be analyzed. The type and size of the automatic fire-suppression system for each necessary application shall be determined. As prescribed in § 238.115(e), a fixed, automatic fire suppression system shall be installed in unoccupied compartments where the analysis determines it is necessary and practical to ensure sufficient time for the safe evacuation of the train. The analysis shall provide the reasoning why a fixed, automatic fire-suppression system is not necessary or practical if the decision is made not to install one in any of the unoccupied compartments identified in the plan.

(12) Develop and adopt written procedures for the inspection, testing, and maintenance of all fire safety systems and equipment. As prescribed in § 238.115(f), the railroad shall comply with those procedures that it designates as mandatory.

(c) The operating railroad shall reasonably ensure in its contracts for the purchase of new equipment that the system developer follows the design criteria and performs the tests required by the fire protection part of the railroad's system safety plan and program.

(d)(1) Not later than 365 days following [the effective date of the final rule] each passenger railroad shall complete a preliminary fire safety analysis for each category of existing rail equipment and current rail service.

(2) Not later than 730 days following [the effective date of the final] rule each such railroad shall—

(i) Complete a final fire safety analysis (equivalent to that required for new equipment in this section) for any category of existing equipment and service evaluated during the preliminary fire safety analysis as likely presenting an unacceptable risk of personal injury, including consideration of the extent to which interior materials comply with the test performance criteria for flammability and smoke emission characteristics contained in Appendix B to this part or alternative

standards approved by FRA under this part; and

(ii) Take remedial action to reduce the risk of personal injuries to an acceptable level in any such category.

(3) Within 1460 days following the effective date of the final rule, the railroad shall complete a fire safety analysis for all categories of equipment and service. In completing this analysis, the railroad shall, to the extent practicable, determine the extent to which remaining interior materials comply with the test performance criteria for flammability and smoke emission characteristics contained in Appendix B to this part or alternative standards approved by FRA under this part and, based on the fire safety analysis, take remedial action to reduce the risk of personal injuries to an acceptable level in any such category.

(4) Where possible prior to transferring existing equipment to a new category of service, but in no case more than 90 days following such a transfer, the passenger railroad shall complete a new fire safety analysis taking into consideration the change in railroad operations and shall effect prompt action to reduce any identified risk to an acceptable level.

(5) As used in this paragraph, "category of rail equipment and current rail service" shall be determined by the railroad based on relevant fire safety risks, including available ignition sources, presence or absence of heat/smoke detection systems, known variations from required interior material test performance criteria or alternative standards approved by FRA, and availability of rapid and safe egress to the exterior of the vehicle under conditions secure from fire, smoke, and other hazards.

§ 238.107 Software safety program.

(a) The operating railroad shall develop and maintain a software safety program to guide the design, development, testing, integration, and verification of computer programs used to control or monitor equipment safety functions.

(b) The software safety program shall:

(1) Treat system software that controls or monitors safety functions as safety-critical unless a completely redundant, failsafe, non-software means to provide the same function is provided; and

(2) Include a description of how the following tasks will be accomplished, or objectives achieved, to ensure safe, reliable system software used to monitor or perform safety functions:

(i) The software design process used;

(ii) The software design documentation to be produced;

(iii) A software hazard analysis;

(iv) Software safety reviews;

(v) Software hazard monitoring and tracking;

(vi) Hardware and software integration safety tests; and

(vii) Demonstration of overall software safety as part of the pre-revenue service tests of equipment.

(c) The operating railroad shall ensure that the system developer follows the design criteria and performs the tests required by the software safety part of the system safety program. To fulfill this obligation in part, the operating railroad shall include software safety requirements in each of its contracts for the purchase of new equipment or new components of existing equipment that contain safety-critical software.

(d) The operating railroad shall follow the software safety procedures required by the software safety part of the system safety program.

§ 238.109 Inspection, testing, and maintenance program.

With respect to Tier II passenger equipment operated by a railroad, fulfillment of the requirements of § 238.503 to file an inspection, testing, and maintenance program with FRA satisfies the requirement of § 238.103(c)(3) to address the railroad's inspection, testing, and maintenance program for such equipment in the railroad's system safety plan.

The following provisions of this section apply only to Tier I equipment operated by the railroad.

(a) *General.* Each railroad shall provide to FRA, upon request, detailed information, consistent with the requirements of this part, on the inspection, testing, and maintenance procedures necessary for the railroad to safely operate Tier I equipment. This information shall include a detailed description of:

(1) Safety inspection procedures, intervals, and criteria;

(2) Test procedures and intervals;

(3) Scheduled preventive maintenance intervals;

(4) Maintenance procedures; and

(5) Special testing equipment or measuring devices required to perform safety inspections and tests.

(b) *General inspection, testing, and maintenance procedures.* The inspection, testing, and maintenance program shall contain procedures reasonably to ensure that all systems and components of the equipment are free of all general conditions that endanger the safety of the crew, passengers, or equipment, including procedures to ensure that all systems and components of the equipment are

free of the following conditions that endanger the safety of the crew, passengers, or equipment:

(1) A continuous accumulation of oil or grease;

(2) Improper functioning of a component;

(3) A crack, break, excessive wear, structural defect, or weakness of a component;

(4) A leak;

(5) Use of a component or system under a condition that exceeds that for which the component or system is designed to operate; and

(6) Insecure attachment of a component.

(c) *Maintenance intervals.* Initial scheduled maintenance intervals should be based on analysis completed as part of the system safety program. The intervals should be changed only when justified by accumulated, verifiable operating data.

(d) *Standard procedures for safely performing inspection, testing, and maintenance, or repairs.* Each railroad shall establish written standard procedures for performing all safety-critical or potentially hazardous equipment inspection, test, maintenance, or repair tasks. These standard procedures shall be available to FRA upon request and shall:

(1) Describe in detail each step required to safely perform the task;

(2) Describe the knowledge necessary to safely perform the task;

(3) Describe any precautions that shall be taken to safely perform the task;

(4) Describe the use of any safety equipment necessary to perform the task;

(5) Be approved by the railroad's chief mechanical officer;

(6) Be approved by the railroad's official responsible for safety;

(7) Be enforced by supervisors with responsibility for accomplishing the tasks; and

(8) Be reviewed annually by the railroad.

§ 238.111 Training, qualification, and designation program.

(a) Each railroad shall adopt and comply with a training, qualification, and designation program for employees and contractors that perform safety-related inspections, tests, or maintenance of passenger equipment. For purposes of this section, a "contractor" is defined as a person under contract with the railroad or an employee of a person under contract with the railroad.

(b) As part of this program, the railroad shall, at a minimum:

(1) Identify the safety-related tasks that must be performed on each type of equipment that the railroad operates;

(2) Develop written procedures for the performance of the tasks identified;

(3) Identify the skills and knowledge necessary to perform each task;

(4) Develop a training course that includes classroom and "hands-on" lessons designed to impart the skills and knowledge identified as necessary to perform each task;

(5) Require all employees and contractors to successfully complete the training course that covers the equipment and tasks for which they are responsible;

(6) Require all employees and contractors to pass a written examination covering the equipment and tasks for which they are responsible;

(7) Require all employees and contractors to demonstrate "hands-on" capability to perform their assigned tasks on the type equipment to which they are assigned;

(8) Require supervisors to complete the program that covers the employees that they supervise;

(9) Require supervisors to exercise oversight to ensure that all the identified tasks are performed in accordance with the railroad's written procedures;

(10) Designate in writing that each employee and contractor has the knowledge and skills necessary to perform the safety-related tasks that are part of his or her job;

(11) Require periodic refresher training at an interval not to exceed three years that includes classroom and "hands-on" training, as well as testing;

(12) Add new equipment to the qualification and designation program prior to its introduction to revenue service; and

(13) Maintain records adequate to demonstrate that each employee and contractor performing safety-related tasks on passenger equipment is currently qualified to do so. These records shall be adequate to distinguish the qualifications of the employee or contractor as a qualified person or as a qualified mechanical inspector.

§ 238.113 Pre-revenue service acceptance testing plan.

(a) Except as provided in paragraph (f), before using passenger equipment for the first time on its system the operating railroad shall submit a pre-revenue service acceptance testing plan containing the information required by paragraph (e) of this section and obtain the approval of the FRA Associate Administrator for Safety, under the procedures specified in § 238.21.

(b) After receiving FRA approval of the pre-revenue service testing plan and before introducing the passenger equipment into revenue service, the operating railroad shall:

(1) Adopt and comply with such FRA-approved plan, including fully executing the tests required by the plan;

(2) Report to the FRA Associate Administrator for Safety the results of the pre-revenue service acceptance tests;

(3) Correct any safety deficiencies identified by FRA in the design of the equipment or in the inspection, testing, and maintenance procedures or, if safety deficiencies cannot be corrected by design changes, agree to comply with any operational limitations that may be imposed by the Associate Administrator for Safety on the revenue service operation of the equipment; and

(4) Obtain FRA approval to place the equipment in revenue service.

(c) The operating railroad shall comply with any such operational limitations imposed by the Associate Administrator for Safety.

(d) The plan shall be made available to FRA for inspection and copying upon request.

(e) The plan shall include all of the following elements:

(1) An identification of any waivers of FRA or other Federal safety regulations required for the tests or for revenue service operation of the equipment.

(2) A clear statement of the test objectives. One of the principal test objectives shall be to demonstrate that the equipment meets the safety design and performance requirements specified in this part when operated in the environment in which it is to be used.

(3) A planned schedule for conducting the tests.

(4) A description of the railroad property or facilities to be used to conduct the tests.

(5) A detailed description of how the tests are to be conducted. This description shall include:

(i) An identification of the equipment to be tested;

(ii) The method by which the equipment is to be tested;

(iii) The criteria to be used to evaluate the equipment's performance; and

(iv) The means by which the test results are to be reported to FRA.

(6) A description of any special instrumentation to be used during the tests.

(7) A description of the information or data to be obtained.

(8) A description of how the information or data obtained is to be analyzed or used.

(9) A clear description of any criteria to be used as safety limits during the testing.

(10) A description of the criteria to be used to measure or determine the success or failure of the tests. If acceptance is to be based on extrapolation of less than full level testing results, the analysis to be done to justify the validity of the extrapolation shall be described.

(11) A description of any special safety precautions to be observed during the testing.

(12) A written set of standard operating procedures to be used to ensure that the testing is done safely.

(13) Quality control procedures to ensure that the inspection, testing, and maintenance procedures are followed.

(14) Criteria to be used for the revenue service operation of the equipment.

(15) A description of any testing of the equipment that has previously been performed.

(f) For passenger equipment that has previously been used in revenue service in the United States, the railroad shall test the equipment on its system, prior to placing it in revenue service, to ensure the compatibility of the equipment with the operating system (track, signals, etc.) of the railroad. A description of such testing shall be retained by the railroad and made available to FRA for inspection and copying upon request.

General Requirements

§ 238.115 Fire safety.

(a)(1) All materials used in constructing the interior of both a passenger car and a cab of a locomotive ordered on or after January 1, 1999, or placed in service for the first time on or after January 1, 2001, shall meet the test performance criteria for flammability and smoke emission characteristics contained in Appendix B to this part or alternative standards issued or recognized by an expert consensus organization after special approval of FRA's Associate Administrator for Safety under § 238.21.

(2) On or after [the effective date of the final rule], all materials used in refurbishing the interior of a passenger car and a locomotive cab shall meet the test performance criteria for flammability and smoke emission characteristics contained in Appendix B to this part or alternative standards issued or recognized by an expert consensus organization after special approval of FRA's Associate Administrator for Safety under § 238.21. Refurbishing includes replacing an individual component such as a seat cushion.

(3) For purposes of this section the interior of a passenger car and a

locomotive cab includes walls, floors, ceilings, seats, doors, windows, electrical conduits, air ducts, and any other internal equipment.

(b) A railroad shall require certification that combustible materials to be used in constructing or refurbishing passenger car and locomotive cab interiors have been tested by a recognized independent testing laboratory and that the results comply with the requirements of paragraph (a) of this section.

(c) Overheat detectors shall be installed in all components of passenger equipment where the written analysis required by § 238.105(b)(8) determines that such equipment is necessary.

(d) Fire or smoke detectors shall be installed in unoccupied compartments of a train if the analysis required by § 238.105(b)(9) determines that such equipment is necessary to ensure sufficient time for the safe evacuation of the train.

(e) A fixed, automatic fire suppression system shall be installed in unoccupied compartments of a train if the analysis required by § 238.105(b)(11) determines that such a system is necessary and practical to ensure sufficient time for the safe evacuation of the train.

(f) The railroad shall comply with those elements of its written procedures, under § 238.105(b)(12), for the inspection, testing, and maintenance of all fire safety systems and equipment that it has designated as mandatory.

(g) After completing each fire safety analysis required by § 238.105(d), the railroad shall take action to reduce the risk of personal injuries as provided in that paragraph.

§ 238.117 Protection against personal injury.

On or after January 1, 1998, all moving parts, high voltage equipment, electrical conductors and switches, and pipes carrying hot fluids or gases on all passenger equipment shall be appropriately equipped with interlocks or guards to minimize the chance of personal injury.

§ 238.119 Rim-stamped straight-plate wheels.

(a) On or after January 1, 1998, no railroad shall place or continue in service any vehicle equipped with a rim-stamped straight-plate wheel, except for a private car.

(b) A rim-stamped straight-plate wheel shall not be used as a replacement wheel on a private car operated in a passenger train.

§ 238.121 Train system software and hardware.

Electrical and electronic systems, including software components, used to control safety functions of passenger equipment shall be treated as safety-critical by the operating railroad. Safety-critical systems utilized in equipment ordered on or after January 1, 1999, and such systems implemented or materially modified for new or existing equipment on or after January 1, 2001, shall conform with the following requirements:

(a) A formal safety methodology shall be used to develop electrical and electronic control systems that control safety functions for computer hardware and software. The safety methodology shall include a Failure Modes, Effects, Criticality Analysis (FMECA) and verification tests for all components of the control system and its interfaces for computer hardware and software.

(b) A comprehensive hardware and software integration program for safety-critical systems shall be adopted and complied with to ensure that the software functions as intended when installed in a hardware system identical to that to be used in service.

(c) Safety-related control systems driven by computer software shall include hardware and software design features that result in a safe condition in the event of a computer hardware or software failure.

§ 238.123 Emergency lighting.

(a) This section applies to each locomotive and passenger car ordered or rebuilt on or after January 1, 1999, or placed in service for the first time on or after January 1, 2001. This section applies to each level of a bi-level unit.

(b) Emergency lighting shall be provided and shall include the following:

(1) An illumination level of a minimum of 5 foot-candles at floor level for all potential passenger and crew evacuation routes from the equipment; and

(2) A back-up power system capable of:

(i) Operating in all equipment orientations within 45 degrees of vertical;

(ii) Operating after the initial shock of a collision or derailment resulting in the following individually applied accelerations:

(A) Longitudinal: 8g;

(B) Lateral: 4g; and

(C) Vertical: 4g; and

(iii) Operating all emergency lighting for a period of at least two hours.

Subpart C—Specific Requirements for Tier I Passenger Equipment**§ 238.201 Scope.**

This subpart contains requirements for railroad passenger equipment operating at speeds not exceeding 125 miles per hour. As stated in § 238.229, all such passenger equipment remains subject to the safety appliance requirements contained in Federal statute at 49 U.S.C. chapter 203 and in FRA regulations at part 231 and § 232.2 of this chapter. Unless otherwise specified, these requirements only apply to passenger equipment ordered on or after January 1, 1999, or placed in service for the first time on or after January 1, 2001.

§ 238.203 Static end strength.

(a) Except as further specified in this paragraph and paragraph (b) of this section, on or after January 1, 1998, all passenger equipment shall have a minimum static end strength of 800,000 pounds without permanent deformation of the car body structure. This requirement does not apply to either—

(1) A private car or
(2) A vehicle of special design that operates at the rear of a passenger train and is used solely to transport freight, such as an auto-carrier or a RoadRailer.

(b) On or after January 1, 1998, each locomotive and passenger car shall have a minimum static end strength of 800,000 pounds on the line of draft at the ends of occupied volumes without permanent deformation of the car body structure. The static end strength of unoccupied volumes may be less than 800,000 pounds if a crash energy management design is used.

(c) When overloaded in compression, the car body structure of passenger equipment shall be designed, to the maximum extent possible, to fail by buckling or crushing, or both, of structural members rather than by fracture of structural members or failure of structural connections.

§ 238.205 Anti-climbing mechanism.

(a) Except as provided in paragraph (b) of this section, all passenger equipment placed in service for the first time on or after January 1, 1998, shall have at both the forward and rear ends an anti-climbing mechanism capable of resisting an upward or downward vertical force of 100,000 pounds without failure. When coupled together in any combination to join two vehicles, AAR Type H and Type F tight-lock couplers satisfy this requirement.

(b) Each locomotive ordered on or after January 1, 1999, or placed in service for the first time on or after

January 1, 2001, shall have an anti-climbing mechanism at its forward end capable of resisting an upward or downward vertical force of 200,000 pounds without failure, in lieu of the forward end anti-climbing mechanism requirements described in paragraph (a) of this section.

§ 238.207 Link between coupling mechanism and car body.

All passenger equipment placed in service for the first time on or after January 1, 1998, shall have a coupler carrier designed to resist a vertical downward thrust from the coupler shank of 100,000 pounds for any normal horizontal position of the coupler, without permanent deformation.

§ 238.209 Forward-facing end structure of locomotives.

The skin covering the forward-facing end of each locomotive shall be:

(a) Equivalent to a ½-inch steel plate with a 25,000 pounds-per-square-inch yield strength—material of a higher yield strength may be used to decrease the required thickness of the material provided an equivalent level of strength is maintained;

(b) Designed to inhibit the entry of fluids into the occupied cab area of the equipment; and

(c) Be affixed to the collision posts or other main vertical structural members of the forward-facing end structure so as to add to the strength of the end structure.

§ 238.211 Collision posts.

(a) Except as further specified in this paragraph and paragraphs (b) and (c) of this section—

(1) All passenger equipment placed in service for the first time on or after January 1, 1998, shall have either:

(i) Two full-height collision posts, located at approximately the one-third points laterally, at each end where coupling and uncoupling are expected. Each collision post shall have an ultimate longitudinal shear strength of not less than 300,000 pounds at a point even with the top of the underframe member to which it is attached. If reinforcement is used to provide the shear value, the reinforcement shall have full value for a distance of 18 inches up from the underframe connection and then taper to a point approximately 30 inches above the underframe connection; or

(ii) An equivalent end structure that can withstand the sum of forces that each collision post is required to withstand. For analysis purposes, the required forces may be assumed to be evenly distributed at the end structure at the underframe joint.

(2) This paragraph does not apply to a vehicle of special design that operates at the rear of a passenger train and is used solely to transport freight, such as an auto-carrier or a RoadRailer.

(b) Each locomotive, including a cab car and an MU locomotive, ordered on or after January 1, 1999, or placed in service for the first time on or after January 1, 2001, shall have at its forward end, in lieu of the structural protection described in paragraph (a) of this section, either:

(1) Two forward collision posts, located at approximately the one-third points laterally, each capable of withstanding:

(i) A 500,000-pound longitudinal force at the point even with the top of the underframe, without exceeding the ultimate strength of the joint; and

(ii) A 200,000-pound longitudinal force exerted 30 inches above the joint of the post to the underframe, without exceeding the ultimate strength; or

(2) An equivalent end structure that can withstand the sum of the forces that each collision post is required to withstand.

(c) If a vehicle consists of articulated units, the end structural protection requirements in paragraphs (a) and (b) of this section apply only to the ends of the permanently joined assembly of units, not to each end of each unit so joined.

§ 238.213 Corner posts.

(a) Each passenger car shall have at each end of the vehicle two full-height corner posts capable of resisting without failure a horizontal load of 150,000 pounds at the point of attachment to the underframe and a load of 20,000 pounds at the point of attachment to the roof structure. The orientation of the applied horizontal loads shall range from longitudinal inward to transverse inward. The corner posts may be positioned near the occupied volume of the rail vehicle to provide protection or structural strength to the occupied volume.

(b) Each corner post shall resist a horizontal load of 30,000 pounds applied 18 inches above the top of the floor without permanent deformation. The orientation of the applied horizontal loads shall range from longitudinal inward to transverse inward.

§ 238.215 Rollover strength.

(a) Each passenger car shall be designed to rest on its side and be uniformly supported at the top ("roof rail"), the bottom ("side sill") chords of the side frame, and, if bi-level, the intermediate floor rail. The allowable

stress for occupied volumes for this condition shall be one-half yield or one-half the critical buckling stress, whichever is less.

(b) Each passenger car shall also be designed to rest on its roof so that any damage in occupied areas is limited to roof sheathing and framing. Deformation to the roof sheathing and framing is allowed to the extent necessary to permit the vehicle to be supported directly on the top chords of the side frames and end frames. Other than roof sheathing and framing, the allowable stress for occupied volumes for this condition shall be one-half yield or one-half the critical buckling stress, whichever is less.

§ 238.217 Side impact strength.

Each passenger car shall comply with the following:

(a) *Side posts and corner braces.* (1) For "modified girder," "semi-monocoque," or truss construction, the sum of the section moduli—about a longitudinal axis, taken at the weakest horizontal section between the side sill and side plate—of all posts and braces on each side of the car located between the body corner posts shall be not less than 0.30 multiplied by the distance in feet between the centers of end panels.

(2) For "modified girder" or "semi-monocoque" construction only, the sum of the section moduli—about a transverse axis, taken at the weakest horizontal section between side sill and side plate—of all posts, braces and pier panels, to the extent available, on each side of the car located between body corner posts shall be not less than 0.20 multiplied by the distance in feet between the centers of end panels.

(3) The center of an end panel is the point midway between the center of the body corner post and the center of the adjacent side post.

(b) *Sheathing.* (1) Outside sheathing of mild, open-hearth steel when used flat, without reinforcement (other than side posts) in a side frame of "modified girder" or "semi-monocoque" shall not be less than 1/8 inch nominal thickness. Other metals may be used of a thickness in inverse proportion to their yield strengths.

(2) Outside metal sheathing of less than 1/8 inch thickness may be used only if it is reinforced so as to produce at least an equivalent sectional area at a right angle to reinforcements as that of the flat sheathing specified in paragraph (b)(1) of this section.

(3) When the sheathing used for truss construction serves no load-carrying function, the minimum thickness of that sheathing shall be not less than 40

percent of that specified in paragraph (b)(1) of this section.

§ 238.219 Truck-to-car-body attachment.

Passenger equipment shall have a truck-to-car-body attachment with an ultimate strength sufficient to resist without failure a force of 2g vertical on the mass of the truck and a force of 250,000 pounds in any horizontal direction. For purposes of this section, the mass of the truck includes axles, wheels, bearings, the truck-mounted brake system, suspension system components, and any other components attached to the truck by design.

§ 238.221 Glazing.

(a) Passenger equipment shall comply with the applicable Safety Glazing Standards contained in part 223 of this chapter, if required by that part.

(b) Glazing securement components shall hold the glazing in place against all forces described in part 223 of this chapter. Securement components shall remain held to the car body structure against these same forces.

(c) Glazing securement components shall be designed to resist the forces due to air pressure differences caused when two trains pass at the minimum separation for two adjacent tracks, while traveling in opposite directions, each train traveling at the maximum authorized speed.

§ 238.223 Fuel tanks.

(a) *External fuel tanks.* External locomotive fuel tanks shall comply with AAR Recommended Practice-506, Performance Requirements for Diesel Electric Locomotive Fuel Tanks (as adopted July 1, 1995), or an industry standard providing at least equivalent safety if approved by FRA's Associate Administrator for Safety under § 238.21.

(b) *Integral fuel tanks.* Integral fuel tanks shall be positioned in a manner to reduce the likelihood of accidental penetration from roadway debris or collision.

(1) The vent system spill protection systems of integral fuel tanks shall be designed to prevent them from becoming a path of fuel loss for any tank orientation due to a locomotive overturning.

(2) The bulkheads and skin of integral fuel tanks shall at a minimum be made of steel plate 3/8 of an inch thick with a 25,000-lb yield strength, or made of material with an equivalent strength. Skid plates are not required. Higher yield strength material may be used to decrease the thickness of the material as long as an equivalent strength is maintained.

§ 238.225 Electrical system.

All passenger equipment shall comply with the following:

(a) *Conductors.* Conductor sizes shall be selected on the basis of current-carrying capacity, mechanical strength, temperature, flexibility requirements, and maximum allowable voltage drop. Current-carrying capacity shall be derated for grouping and for operating temperature.

(b) *Main battery system.* (1) The main battery compartment shall be isolated from the cab and passenger seating areas by a non-combustible barrier.

(2) Battery chargers shall be designed to protect against overcharging.

(3) If batteries are of the type to potentially vent explosive gases, the battery compartment shall be adequately ventilated to prevent the accumulation of explosive concentrations of these gases.

(c) *Power dissipation resistors.* (1) Power dissipating resistors shall be adequately ventilated to prevent overheating under worst-case operating conditions as determined by each railroad.

(2) Power dissipation grids shall be designed and installed with sufficient isolation to prevent combustion.

(3) Resistor elements shall be electrically insulated from resistor frames, and the frames shall be electrically insulated from the supports that hold them.

(d) *Electromagnetic interference and compatibility.* (1) The operating railroad shall ensure electromagnetic compatibility of the safety-critical equipment systems with their environment. Electromagnetic compatibility may be achieved through equipment design or changes to the operating environment.

(2) The electronic equipment shall not produce electrical noise that affects the safe performance of train line control and communications or wayside signaling systems.

(3) To contain electromagnetic interference emissions, suppression of transients shall be at the source wherever possible.

(4) All electronic equipment shall be self-protected from damage or improper operation, or both, due to high voltage transients and long-term over-voltage or under-voltage conditions. This includes protection from both power frequency and harmonic effects as well as protection from radio frequency signals into the microwave frequency range.

§ 238.227 Suspension system.

On or after January 1, 1998—

(a) All passenger equipment shall exhibit freedom from hunting oscillations at all speeds.

(b) All passenger equipment intended for service above 110 mph shall demonstrate stable operation during pre-revenue service qualification tests at all speeds up to 5 mph in excess of the maximum intended operating speed under worst-case conditions—including component wear—as determined by the operating railroad.

§ 238.229 Safety appliances.

All passenger equipment continues to be subject to the safety appliance requirements contained in Federal statute at 49 U.S.C. chapter 203 and in FRA regulations at part 231 and § 232.2 of this chapter.

§ 238.231 Brake system.

Except as otherwise provided in this section, on or after January 1, 1998, the following requirements apply to all passenger equipment and passenger trains.

(a) A passenger train's primary brake system shall be capable of stopping the train with a service application from its maximum authorized operating speed within the signal spacing existing on the track over which the train is operating.

(b) The brake system design of passenger equipment ordered on or after January 1, 1999, or placed in service for the first time on or after January 1, 2001, shall not require an inspector to place himself or herself on, under, or between components of the equipment to observe brake actuation or release.

(c) Passenger equipment shall be provided with an emergency application feature that produces an irretrievable stop, using a brake rate consistent with prevailing adhesion, passenger safety, and brake system thermal capacity. An emergency application shall be available at any time, and shall be initiated by an unintentional parting of the train.

(d) A passenger train brake system shall respond as intended to signals from train brake control line or lines. Control lines shall be designed so that failure or breakage of a control line will cause the brakes to apply or will result in a default to control lines that meet this requirement.

(e) Introduction of alcohol or other chemicals into the air brake system of passenger equipment is prohibited.

(f) The operating railroad shall require that the design and operation of the brake system results in wheels that are free of condemnable cracks.

(g) Disc brakes shall be designed and operated to produce a surface temperature no greater than the safe operating temperature recommended by

the disc manufacturer and verified by testing or previous service.

(h) Except for a locomotive that is ordered before January 1, 1999, and placed in service for the first time before January 1, 2001, and except for a private car, all passenger equipment shall be equipped with a hand or parking brake that shall be:

- (1) Capable of application or activation by hand;
- (2) Capable of release by hand; and
- (3) Capable of holding the loaded unit on the maximum grade anticipated by the operating railroad.

(i) Passenger cars shall be equipped with a means to apply the emergency brake that is accessible to passengers and located in the vestibule or passenger compartment. The emergency brake shall be clearly identified and marked.

(j) Locomotives equipped with blended brakes shall be designed so that:

- (1) The blending of friction and dynamic brake to obtain the correct retarding force is automatic;
- (2) Loss of power or failure of the dynamic brake does not result in exceeding the allowable stop distance;
- (3) The friction brake alone is adequate to safely stop the train under all operating conditions; and
- (4) Operation of the friction brake alone does not result in thermal damage to wheels or disc rotor surface temperatures exceeding the manufacturer's recommendation.

(k) For new designs of braking systems, the design process shall include computer modeling or dynamometer simulation of train braking that shows compliance with paragraphs (f) and (g) of this section over the range of equipment operating speeds. Changes in operating parameters shall require a new simulation prior to implementing the changes.

(l) Locomotives ordered on or after January 1, 1999, or placed in service for the first time on or after January 1, 2001, shall be equipped with effective air coolers or dryers that provide air to the main reservoir with a dew point at least 10 degrees F. below ambient temperature.

§ 238.233 Interior fittings and surfaces.

(a) Each seat in a passenger car shall be securely fastened to the car body so as to withstand an individually applied acceleration of 4g acting in the vertical and in the lateral direction on the deadweight of the seat or seats, if a tandem unit. A seat attachment shall have an ultimate strength capable of resisting the longitudinal inertial force of 8g acting on the mass of the seat plus

the impact force of the mass of a 95th-percentile male occupant(s) being decelerated from a relative speed of 25 mph and striking the seat from behind.

(b) Overhead storage racks in a passenger car shall provide longitudinal and lateral restraint for stowed articles. Overhead storage racks shall be attached to the car body with sufficient strength to resist loads due to the following individually applied accelerations acting on the mass of the luggage stowed as determined by the railroad:

- (1) Longitudinal: 8g;
- (2) Vertical: 4g; and
- (3) Lateral: 4g.

(c) Other interior fittings within a passenger car shall be attached to the car body with sufficient strength to withstand the following individually applied accelerations acting on the mass of the fitting:

- (1) Longitudinal: 8g;
- (2) Vertical: 4g; and
- (3) Lateral: 4g.

(d) To the extent possible, all interior fittings in a passenger car, except seats, shall be recessed or flush-mounted.

(e) Sharp edges and corners in a locomotive cab and a passenger car shall be either avoided or padded to mitigate the consequences of an impact with such surfaces.

(f) Each floor-mounted seat provided exclusively for a crewmember assigned to occupy the cab of a locomotive shall be secured to the car body with an attachment having an ultimate strength capable of withstanding the loads due to the following individually applied accelerations acting on the mass of the seat and the crewmember (ranging from a 5th-percentile female to a 95th-percentile male) occupying it:

- (1) Longitudinal: 8g;
- (2) Lateral: 4g; and
- (3) Vertical: 4g.

§ 238.235 Emergency window exits.

Except as provided in paragraph (b), the following requirements apply to all passenger cars on or after January 1, 1998—

(a) Except as provided in paragraphs (d) and (e) of this section, each passenger car shall have a minimum of four emergency window exits, either in a staggered configuration or with one located at each end of each side of the car.

(b) Each emergency window exit in a passenger car placed in service for the first time on or after January 1, 1998, shall have a minimum unobstructed opening with dimensions of 24 inches horizontally by 18 inches vertically.

(c) Each emergency window exit shall be easily operable by a 5th-percentile female without requiring the use of a tool or other implement.

(d) If the car is bi-level, each main level shall have a minimum of four emergency window exits, either in a staggered configuration or with one located at each end of each side of the car.

(e) Each passenger car of special design, such as a sleeping car, shall have at least one emergency window exit in each compartment.

(f) *Marking and instructions.*
[Reserved]

§ 238.237 Doors.

(a) Within 2 years of the effective date of the final rule, each powered, exterior side door in a vestibule that is partitioned from the passenger compartment of a passenger car shall be equipped with a manual override that is:

- (1) Capable of opening the door without power from inside the car;
- (2) Located adjacent to the door which it controls; and
- (3) Designed and maintained so that a person may access the override device from inside the car without requiring the use of a tool or other implement.

(b) Each passenger car ordered on or after January 1, 1999, or placed in service for the first time on or after January 1, 2001, shall have a minimum of four side doors, or the functional equivalent of four side doors, each permitting at least one 95th-percentile male to pass through at a single time.¹ Each powered, exterior side door shall be equipped with a manual override that is:

- (1) Capable of opening the door without power from both inside and outside the car;
- (2) Located adjacent to the door which it controls; and
- (3) Designed and maintained so that a person may access the override device from both inside and outside the car without requiring the use of a tool or other implement.

(c) A railroad may protect a manual override device used to open a powered, exterior door with a cover or a screen capable of removal by a 5th-percentile female without requiring the use of a tool or other implement. If the method of removing the protective cover or screen entails breaking or shattering it, the cover or screen shall be scored, perforated, or otherwise weakened so that a 5th-percentile female can penetrate the cover or screen with a single blow of her fist without injury to her hand.

¹The Americans with Disabilities Act (ADA) Accessibility Specifications for Transportation Vehicles also contain requirements for doorway clearance (See Title 49 Code of Federal Regulations Part 38).

(d) *Marking and instructions.*
[Reserved]

§ 238.239 Automated monitoring.

(a) Except as further specified in this paragraph, on or after January 1, 1998, a working alerter or deadman control shall be provided in the controlling locomotive of each passenger train operating in other than cab signal, automatic train control, or automatic train stop territory. If the controlling locomotive is ordered on or after January 1, 1999, or placed into service for the first time on or after January 1, 2001, a working alerter shall be provided.

(b) Alerter or deadman control timing shall be set by the operating railroad taking into consideration maximum train speed and capabilities of the signal system. The railroad shall document the basis for setting alerter or deadman control timing and make this documentation available to FRA upon request.

(c) If the train operator does not respond to the alerter or maintain proper contact with the deadman control, it shall initiate a penalty brake application.

(d) The following procedures apply if the alerter or deadman control fails en route:

- (1) A second person qualified on the signal system and brake application procedures shall be stationed in the cab; or
- (2) The engineer shall be in constant communication with a second crewmember until the train reaches the next terminal.

Subpart D—Inspection, Testing, and Maintenance Requirements for Tier I Passenger Equipment

§ 238.301 Scope.

This subpart contains requirements pertaining to the inspection, testing, and maintenance of passenger equipment operating at speeds not exceeding 125 miles per hour. The requirements in this subpart address the inspection, testing, and maintenance of the brake system as well as other mechanical and electrical components covered by this part.

§ 238.303 Exterior calendar day mechanical inspection of passenger cars and unpowered vehicles used in passenger trains.

(a) Except as provided in paragraph (d) of this section, each passenger car and each unpowered vehicle used in a passenger train shall receive an exterior mechanical safety inspection at least once each calendar day that the equipment is placed in service. (Note: The exterior inspection of a passenger

car classified as a locomotive under part 229 of this chapter shall be in accordance with this part as well as part 229 of this chapter.)

(b) The exterior calendar day mechanical safety inspection shall be performed by a qualified mechanical inspector as defined in § 238.5.

(c) As part of the exterior inspection, the railroad shall verify conformity with the following conditions, and nonconformity with any such condition renders the passenger car or unpowered vehicle used in a passenger train defective whenever discovered in service:

- (1) Products of combustion are released entirely outside the cab and other compartments.
- (2) All battery containers are vented and all batteries are kept from gassing excessively.
- (3) Each coupler is in the following condition:
 - (i) The distance between the guard arm and the knuckle nose is not more than 5¹/₈ inches on standard type couplers (MCB contour 1904) or more than 5⁹/₁₆ inches on D&E couplers;
 - (ii) Sidewall or pin bearing bosses and the pulling face of the knuckles are not broken or cracked;
 - (iii) The coupler assembly is equipped with anti-creep protection;
 - (iv) The free slack in the coupler or drawbar not absorbed by friction devices or draft gears is not more than 1/2 inch;
 - (v) The coupler carrier is not broken or cracked;
 - (vi) The yoke is not broken or cracked; and
 - (vii) The draft gear is not broken.

(4) A device is provided under the lower end of all drawbar pins and articulated connection pins to prevent the pin from falling out of place in case of breakage.

(5) The suspension system, including the spring rigging, is in the following condition:

- (i) Protective construction or safety hangers are provided to prevent spring planks, spring seats, or bolsters from dropping to the track structure in event of a hanger or spring failure;
- (ii) The top (long) leaf or any of the other three leaves of the elliptical spring is not broken, except when a spring is part of a nest of three or more springs and none of the other springs in the nest has its top leaf or any of the other three leaves broken;
- (iii) The outer coil spring or saddle is not broken;
- (iv) The equalizers, hangers, bolts, gibs, or pins are not cracked or broken;
- (v) The coil spring is not fully compressed when the car is at rest;

(vi) The shock absorber is not broken or leaking clearly formed droplets of oil or other fluid; and

(vii) Air bags or other pneumatic suspension system components inflate or deflate, as applicable, correctly and otherwise operate as intended.

(6) All trucks are in the following condition:

(i) Equipped with a device or securing arrangement to prevent the truck and car body from separating in case of derailment;

(ii) All tie bars are not loose;

(iii) All center castings, motor suspension lugs, equalizers, hangers, gibs, or pins are not cracked or broken; and

(iv) The truck frame is not broken and is not cracked in a stress area that may affect its structural integrity.

(7) All side bearings are in the following condition:

(i) All friction side bearings with springs designed to carry weight do not have more than 25 percent of the springs in any one nest broken;

(ii) All friction side bearings do not run in contact unless designed to carry weight; and

(iii) The maximum clearance of all side bearings does not exceed the manufacturer's recommendation.

(8) All wheels do not have any of the following conditions:

(i) A single flat spot that is 2½ inches or more in length, or two adjoining spots that are each two or more inches in length;

(ii) A gouge or chip in the flange that is more than 1½ inches in length and ½ inch in width;

(iii) A broken rim, if the tread, measured from the flange at a point ⅝ of an inch above the tread, is less than ¾ inches in width.

(iv) A shelled-out spot 2½ inches or more in length, or two adjoining spots that are each two or more inches in length;

(v) A seam running lengthwise that is within ¾ inches of the flange;

(vi) A flange worn to a ⅞ inch thickness or less, gauged at a point ⅜ of an inch above the tread;

(vii) A tread worn hollow ⅕ inch or more;

(viii) A flange height of 1½ inches or more measured from the tread to the top of the flange;

(ix) A rim less than 1 inch thick;

(x) A crack or break in the flange, tread, rim, plate, or hub;

(xi) A loose wheel; or

(xii) A weld.

(9) No part or appliance of a passenger coach, except the wheels, is less than 2½ inches above the top of the rail.

(10) All unguarded, noncurrent-carrying metal parts subject to becoming

charged are grounded or thoroughly insulated.

(11) All jumpers and cable connections are in the following condition:

(i) All jumpers and cable connections between coaches, between locomotives, or between a locomotive and a coach are located and guarded in a manner that provides sufficient vertical clearance. Jumpers and cable connections may not hang with one end free;

(ii) The insulation is not broken or badly chafed;

(iii) No plug, receptacle, or terminal is broken; and

(iv) No strand of wire is broken or protruding.

(12) All doors and cover plates guarding high voltage equipment are marked "Danger—High Voltage" or with the word "Danger" and the normal voltage carried by the parts so protected.

(13) All buffer plates are in place.

(14) If so equipped, all diaphragms are in place and properly aligned.

(15) All secondary braking systems are working.

(d) A long-distance intercity passenger train that misses a scheduled exterior calendar day mechanical inspection due to a delay en route may continue in service to the location where the inspection was scheduled to be performed. At that point, an exterior calendar day mechanical inspection shall be performed prior to returning the equipment to service. This flexibility applies only to the exterior mechanical safety inspections required by this section, and does not relieve the railroad of the responsibility to perform a calendar day inspection on a unit classified as a "locomotive" under part 229 of this chapter as required by § 229.21 of this chapter.

(e) Cars requiring a single car test in accordance with § 238.311 that are being moved in service to a location where the single car test can be performed shall have the single car test completed prior to, or as a part of, the calendar day mechanical inspection.

§ 238.305 Interior calendar day mechanical inspection of passenger cars.

(a) Except as provided in paragraph (d) of this section, each passenger car shall receive an interior mechanical safety inspection at least once each calendar day that it is placed in service.

(b) The interior daily mechanical inspection shall be performed by a qualified person or a qualified mechanical inspector.

(c) As part of the daily interior mechanical inspection, the railroad shall verify conformity with the following conditions, and

nonconformity with any such condition renders the car defective whenever discovered in service, except as provided in paragraph (c)(5) of this section:

(1) All fan openings, exposed gears and pinions, exposed moving parts of mechanisms, pipes carrying hot gases and high-voltage equipment, switches, circuit breakers, contactors, relays, grid resistors, and fuses are in non-hazardous locations or equipped with guards to prevent personal injury.

(2) The words "Emergency Brake Valve" are legibly stenciled or marked near each brake pipe valve or shown on an adjacent badge plate.

(3) All doors and cover plates guarding high voltage equipment are marked "Danger—High Voltage" or with the word "Danger" and the normal voltage carried by the parts so protected.

(4) All trap doors safely operate and securely latch in place in both the up and down position.

(5) All end doors and side doors operate safely and as intended. If all of the following conditions are satisfied, the car may remain in passenger service until the next interior calendar day mechanical inspection is due at which time the appropriate repairs shall be made:

(i) A qualified person or a qualified mechanical inspector determines that the repairs necessary to bring a door into compliance cannot be performed at the time the interior mechanical inspection is conducted;

(ii) A qualified person or a qualified mechanical inspector determines that it is safe to move the equipment in passenger service; and

(iii) A tag is prominently displayed on the door indicating that the door is defective.

(6) All safety-related signage is in place and legible.

(7) All vestibule steps are illuminated.

(8) All manual door releases are in place based on a visual inspection.

(d) A long-distance intercity passenger train that misses a scheduled calendar day interior mechanical inspection due to a delay en route may continue in service to the location where the inspection was scheduled to be performed. At that point, an interior calendar day mechanical inspection shall be performed prior to returning the equipment to service.

§ 238.307 Periodic mechanical inspection of passenger cars.

(a) Railroads shall conduct periodic inspections of passenger cars as required by this section and as warranted by data developed under §§ 238.103 and 238.109. A periodic

inspection conducted under part 229 of this chapter satisfies the requirement of this section with respect to the features inspected.

(b) The periodic inspection program shall specifically include the following interior features, which shall be inspected not less frequently than each 180 days. At a minimum, this inspection shall determine that:

(1) Floors of passageways and compartments are free from oil, water, waste, or any obstruction that creates a slipping, tripping, or fire hazard, and floors are properly treated to provide secure footing.

(2) Emergency lighting systems are operational.

(3) With regard to switches:

(i) All hand-operated switches carrying currents with a potential of more than 150 volts that may be operated while under load are covered and are operative from the outside of the cover;

(ii) A means is provided to display whether the switches are open or closed; and

(iii) Switches not designed to be operated safely while under load are legibly marked with the voltage carried and the words "must not be operated under load".

(4) Seats and seat attachments are not broken or loose.

(5) Luggage racks are not broken or loose.

(6) All beds and bunks are not broken or loose, and all restraints or safety latches and straps are in place and function as intended.

(7) A representative sample of emergency window exits on its cars properly operate, in accordance with the requirements of § 239.107 of this chapter.

(8) All manual door releases operate as intended.

(c) Nonconformity with any of the conditions set forth in this section renders the car defective whenever discovered in service.

§ 238.309 Periodic brake equipment maintenance.

(a) *General.* (1) This section contains the minimum intervals at which the brake equipment on various types of passenger equipment shall be periodically cleaned, repaired, and tested. This maintenance procedure requires that all of the equipment's brake system pneumatic components that contain moving parts and are sealed against air leaks be removed from the equipment, disassembled, cleaned, and lubricated and that the parts that can deteriorate with age be replaced.

(2) A railroad may petition FRA's Associate Administrator for Safety to

approve alternative maintenance procedures providing equivalent safety, in lieu of the requirements of this section. The petition shall be filed as provided in § 238.21.

(b) *MU locomotives.* The brake equipment of each MU locomotive shall be cleaned, repaired, and tested at intervals in accordance with the following schedule:

(1) Every 736 days if the MU locomotive is part of a fleet that is not 100 percent equipped with air dryers.

(2) Every 1,104 days if the MU locomotive is part of a fleet that is 100 percent equipped with air dryers and is equipped with PS-68, 26-C, 26-L, PS-90, CS-1, RT-5A, GRB-1, CS-2, or 26-R brake systems. (This listing of brake system types is intended to subsume all brake systems using 26 type, ABD, or ABDW control valves and PS68, PS-90, 26B-1, 26C, 26CE, 26-B1, 30CDW, or 30ECDW engineer's brake valves.)

(3) Every 736 days for all other MU locomotives.

(c) *Conventional locomotives.* The brake equipment of each conventional locomotive shall be cleaned, repaired, and tested at intervals in accordance with following schedule:

(1) Every 1,104 days for a locomotive equipped with a 26-L or equivalent brake system.

(2) Every 736 days for a locomotive equipped with other than a 26-L or equivalent brake system.

(d) *Passenger coaches and other unpowered vehicles.* The brake equipment on each passenger coach and each other unpowered vehicle used in a passenger train shall be cleaned, repaired, and tested at intervals in accordance with following schedule:

(1) Every 1,476 days for a coach or vehicle equipped with a 26-C or equivalent brake system.

(2) Every 1,104 days for a coach or vehicle equipped with other than a 26-C or equivalent brake system.

(e) *Cab cars.* The brake equipment of each cab car shall be cleaned, repaired, and tested in accordance with the following schedule:

(1) Every 1,476 days for that portion of the cab car brake system using brake valves that are identical to the passenger coach 26-C brake system;

(2) Every 1,104 days for that portion of the cab car brake system using brake valves that are identical to the locomotive 26-L brake system; and

(3) Every 732 days for all other types of cab car brake valves.

(f) *Records of periodic maintenance.* The date and place of the cleaning, repairing, and testing required by this section shall be recorded on Form FRA 6180-49A or a similar form developed

by the railroad containing the same information, and the person performing the work and that person's supervisor shall sign the form. Alternatively, the railroad may stencil the vehicle with the date and place of the cleaning, repairing, and testing and maintain an electronic record of the person performing the work and that person's supervisor. A record of the parts of the air brake system that are cleaned, repaired, and tested shall be kept in the railroad's files, the cab of the locomotive, or a designated location in the passenger car until the next such periodic test is performed.

§ 238.311 Single car test.

(a) Single car tests of all passenger cars and all unpowered vehicles used in passenger trains shall be performed in accordance with the AAR Standard S-044 contained in AAR "Instruction Pamphlet 5039-4, Supplement 3" (April 1991), or an alternative procedure approved by FRA's Associate Administrator for Safety under § 238.21.

(b) A railroad shall perform a single car test of the brake system of a car or vehicle described in paragraph (a) of this section when the car or vehicle is found with one or more of the following wheel defects:

- (1) Built-up tread;
- (2) Slid flat wheel;
- (3) Thermal cracks;
- (4) Overheated wheel; or
- (5) Shelling.

(c) Except as provided in paragraph (e) of this section, a railroad shall perform a single car test of the brake system of a car or vehicle described in paragraph (a) of this section when:

- (1) The car or vehicle is placed in service after having been out of service for 30 days or more;
- (2) The trainline is repaired; or
- (3) One or more of the following conventional air brake equipment items is removed, repaired, or replaced:

- (i) Brake reservoir;
- (ii) Brake cylinder;
- (iii) Piston assembly;
- (iv) Vent valve;
- (v) Quick service valve;
- (vi) Brake cylinder release valve;
- (vii) Modulating valve or slack adjuster;
- (viii) Relay valve;
- (ix) Angle cock or cutout cock;
- (x) Service portion;
- (xi) Emergency portion; or
- (xii) Pipe bracket.

(d) Each single car test required by this section shall be performed by a qualified mechanical inspector.

(e) If the single car test cannot be made at the point where repairs are made, the car may be moved in

passenger service to the next forward location where the test can be made. The single car test shall be completed prior to, or as a part of, the car's next calendar day mechanical inspection.

§ 238.313 Class I brake test.

(a) Each commuter and short-distance intercity passenger train shall receive a Class I brake test once each calendar day that the train is placed or remains in passenger service.

(b) Except as provided in paragraph (h) of this section, each long-distance intercity passenger train shall receive a Class I brake test:

(1) Prior to the train's departure from an originating terminal; and

(2) Every 1,500 miles or once each additional calendar day, whichever occurs first, that the train remains in continuous passenger service.

(c) Each Class I brake test shall be performed by a qualified mechanical inspector.

(d) Each Class I brake test may be performed either separately or in conjunction with the calendar day mechanical inspection required under § 238.303.

(e) Except as provided in § 238.15(b), a railroad shall not use or haul a passenger train in passenger service from a location where a Class I brake test has been performed, or was required by this part to have been performed, with less than 100 percent operative brakes.

(f) A Class I brake test shall determine and ensure that:

(1) The friction brakes apply and remain applied on each car in the train until a release of the brakes has been initiated on each car in response to train line electric, pneumatic, or other signals. This test shall include a verification that each side of each car's brake system responds properly to application and release signals;

(2) The brake shoes or pads are firmly seated against the wheel or disk with the brakes applied;

(3) Piston travel is within prescribed limits, either by direct observation, observation of an actuator, or by observation of the clearance between the brake shoe and the wheel with the brakes released;

(4) The communicating signal system is tested and known to be operating as intended;

(5) Each brake shoe is securely fastened and aligned in relation to the wheel;

(6) The engineer's brake valve or controller will cause the proper train line commands for each position or brake level setting;

(7) Brake pipe leakage does not exceed 5 pounds-per-square-inch per

minute if leakage will affect service performance;

(8) The emergency brake application and deadman pedal or other emergency control devices function as intended;

(9) Each brake shoe or pad is not below the minimum thickness established by the railroad. This thickness shall not be less than the minimum thickness necessary to safely travel the maximum distance allowed between Class I brake system tests;

(10) Each angle cock and cutout cock is properly positioned;

(11) Brake rigging does not bind or foul so as to impede the force delivered to a brake shoe, impede the release of a brake shoe, or otherwise adversely affect the operation of brake system;

(12) If the train is equipped with electropneumatic brakes, an electropneumatic application of the brakes is made and that the train is walked to determine that the brakes on each car in the train properly apply;

(13) Each brake disc is free of cracks;

(14) If the equipment is provided with a brake indicator, the brake indicator operates as intended; and

(15) The communication of brake pipe pressure changes at the rear of the train is verified.

(g) A qualified mechanical inspector that performs a Class I brake test on a train shall place in the cab of the controlling locomotive of the train a written statement, which shall be retained in the cab until the next Class I brake test is performed and which shall contain the following information:

(1) Date and time the Class I brake test was performed;

(2) Location where the test was performed; and

(3) The number of the controlling locomotive of the train.

(h) A long-distance, intercity passenger train that misses a scheduled calendar day Class I brake test due to a delay en route may proceed to the point where the Class I brake test was scheduled to be performed. A Class I brake test shall be completed at that point prior to placing the train back in service.

§ 238.315 Class IA brake test.

(a) Except as provided in paragraph (b)(1) of this section, either a Class I or Class IA brake test shall be performed:

(1) Prior to the first morning departure of each commuter or short-distance intercity passenger train; and

(2) Prior to placing a train in service that has been off a source of compressed air for more than four hours.

(b) A commuter or short-distance intercity passenger train that provides continuing late night service that began

prior to midnight may complete its daily operating cycle after midnight without performing another Class I or Class IA brake test. A Class I or Class IA brake test shall be performed on such a train before it starts a new daily operating cycle.

(c) A Class I or Class IA test may be performed at a shop or yard site and need not be repeated at the first passenger terminal if the train remains on a source of compressed air and in the custody of the train crew.

(d) The Class IA test shall be performed by either a qualified person or a qualified mechanical inspector as defined in § 238.5.

(e) Except as provided in § 238.15(b), a railroad shall not use or haul a passenger train in passenger service from a location where a Class IA brake test has been performed, or was required by this part to have been performed, with less than 100 percent operative brakes.

(f) In performing a Class IA brake test, it shall be determined that:

(1) Brake pipe leakage does not exceed 5 pounds-per-square-inch per minute if brake pipe leakage will affect service performance;

(2) Each brake sets and releases by inspecting in the manner described in paragraph (g) of this section;

(3) The emergency brake application and the deadman pedal or other emergency control devices function as intended;

(4) Each angle cock and cutout cock is properly set;

(5) To the extent determinable, piston travel is within the nominal range for the type of brake equipment; and

(6) Brake pipe pressure changes at the rear of the train are properly communicated to the controlling locomotive.

(g) In determining whether each brake sets and releases—

(1) The inspection of the set and release of the brakes shall be completed by walking the train to directly observe the set and release of each brake, if the railroad determines that such a procedure is safe.

(2) If the railroad determines that operating conditions pose a safety hazard to an inspector walking the brakes, brake indicators may be used to verify the set and release on cars so equipped. However, the observation of the brake indicators shall not be made from the cab of the locomotive. The inspector shall position himself or herself to be able to accurately observe the indicators.

§ 238.317 Class II brake test.

(a) A Class II brake test shall be performed on a passenger train when any of the following events occur:

- (1) Whenever the control stand used to control the train is changed;
- (2) When previously tested units are added to or removed from the train; and
- (3) When an operator first takes charge of the train, except for face-to-face relief.

(b) A Class II brake test shall be performed by a qualified person or a qualified mechanical inspector.

(c) A railroad shall not use or haul a passenger train in passenger service from a terminal or yard where a Class II brake test has been performed, or was required by this part to have been performed, with any of the brakes known to be cutout, inoperative, or defective.

(d) In performing a Class II brake test on a train, a railroad shall determine that:

- (1) The brakes on the rear unit of the train apply and release in response to a signal from the engineer's brake valve or controller of the leading or controlling unit;
- (2) The emergency brake application and deadman pedal or other emergency control devices function as intended; and
- (3) Brake pipe pressure changes are properly communicated at the rear of the train.

§ 238.319 Running brake test.

(a) As soon as conditions safely permit, a running brake test shall be performed on each passenger train after the train has received, or was required under this part to have received, either a Class I, Class IA, or Class II brake test.

(b) The running brake test shall be conducted in accordance with the railroad's established operating rules, and shall be made by applying brakes in a manner that allows the engineer to ascertain whether the brakes are operating properly.

(c) If the engineer determines that the brakes are not operating properly, the engineer shall stop the train and follow the procedures provided in § 238.15.

Subpart E—Specific Requirements for Tier II Passenger Equipment**§ 238.401 Scope.**

This subpart contains specific requirements for railroad passenger equipment operating at speeds exceeding 125 mph but not exceeding 150 mph. As stated in § 238.433(b), all such passenger equipment remains subject to the requirements concerning couplers and uncoupling devices

contained in Federal statute at 49 U.S.C. chapter 203 and in FRA regulations at part 231 and § 232.2 of this chapter. The requirements of this subpart are effective on the effective date of the final rule.

§ 238.403 Crash energy management requirements.

(a) Each power car and trailer car shall be designed with a crash energy management system to dissipate kinetic energy during a collision. The crash energy management system shall provide a controlled deformation and collapse of designated sections within the unoccupied volumes to absorb collision energy and to reduce the decelerations on passengers and crewmembers resulting from dynamic forces transmitted to occupied volumes.

(b) The design of each unit shall consist of an occupied volume located between two normally unoccupied volumes. Where practical, sections within the unoccupied volumes shall be designed to be structurally weaker than the occupied volume. During a collision, the designated sections within the unoccupied volumes shall start to deform and eventually collapse in a controlled fashion to dissipate energy before any structural damage occurs to the occupied volume.

(c) At a minimum, the train shall be designed to meet the following requirements:

- (1) Thirteen megajoules (MJ) shall be absorbed at each end of the train through the controlled crushing of unoccupied or occasionally occupied spaces, and of this amount a minimum of 5 MJ shall be absorbed outboard of the operator's cab in each power car;
- (2) A minimum of an additional 3 MJ shall be absorbed by the power car structure between the operator's cab and the first trailer car; and
- (3) The end of the first trailer car adjacent to each power car shall absorb a minimum of 5 MJ through controlled crushing.

(d) For a 30-mph collision of a train on tangent, level track with an identical stationary train:

(1) The deceleration of the occupied compartments of each trailer car shall not exceed 10g; and

(2) When seated anywhere in the train, the velocity at which a 50th-percentile male contacts the seat back ahead of him shall not exceed 25 mph.

(e) Compliance with paragraphs (a) through (d) of this section shall be demonstrated by analysis using a dynamic collision computer model. For the purpose of demonstrating compliance, the following assumptions shall be made:

(1) The train remains upright, in-line, and with all wheels on the track throughout the collision; and

(2) Resistance to structural crushing following the force-versus-distance function determined during the structural analysis required under § 238.103 as part of the design of the train.

(f) Passenger searing shall not be permitted in the leading unit of a Tier II train.

§ 238.405 Longitudinal static compressive strength.

(a) To form an effective crash refuge for crewmembers occupying the cab of a power car, the longitudinal ultimate compressive strength of the underframe of the cab of a power car shall be a minimum of 2,100,000 pounds unless equivalent protection to crewmembers is provided under an alternate design approach, validated through analysis and testing, approved by the FRA Associate Administrator for Safety under the provisions of § 238.21.

(b) The longitudinal compressive strength of the underframe of the occupied volume of each trailer car shall be a minimum of 800,000 pounds without deformation. To demonstrate compliance with this requirement, the 800,000-pound load shall be applied to the underframe of the occupied volume as it would be transmitted to the underframe by the full structure of the vehicle.

(c) Unoccupied or lightly occupied volumes of a power car or a trailer car designed to crush as part of the crash energy management design are not subject to the requirements of this section.

§ 238.407 Anti-climbing mechanism.

(a) Each power car shall have an anti-climbing mechanism at its forward end capable of resisting an upward or downward static vertical force of 200,000 pounds. A power car constructed with a crash energy management design is permitted to crush in a controlled manner before the anti-climbing mechanism fully engages.

(b) Interior train coupling points between units, including between units of articulated cars or other permanently joined units of cars, shall have an anti-climbing mechanism capable of resisting an upward or downward vertical force of 100,000 pounds.

(c) The forward coupler of a power car shall be attached to the car body to resist a vertical downward force of 100,000 pounds for any horizontal position of the coupler without yielding.

§ 238.409 Forward end structures of power car cabs.

This section contains the design requirements for the forward end structure of the cab of a power car. (A conceptual implementation of this end structure is provided in Figure 1.)

(a) *Center collision post.* The forward end structure shall have a full-height center collision post, or its structural equivalent, capable of withstanding the following:

(1) A shear load of 500,000 pounds at its joint with the underframe without exceeding the ultimate strength of the joint;

(2) A shear load of 150,000 pounds at its joint with the roof without exceeding the ultimate strength of the joint; and

(3) A horizontal, longitudinal force of 300,000 pounds applied at a point on level with the bottom of the windshield without exceeding the yield or the critical buckling stress.

(b) *Side collision posts.* The forward end structure shall have two side

collision posts, or their structural equivalent, located at approximately the one-third points laterally, each capable of withstanding the following:

(1) A shear load of 500,000 pounds at its joint with the underframe without exceeding the ultimate strength of the joint; and

(2) A horizontal, longitudinal force of 300,000 pounds, applied at a point on level with the bottom of the windshield, without exceeding the yield or the critical buckling stress.

(c) *Corner posts.* The forward end structure shall have two full-height corner posts, or their structural equivalent, each capable of withstanding the following:

(1) A horizontal, longitudinal or lateral shear load of 300,000 pounds at its joint with the underframe, without exceeding the ultimate strength of the joint;

(2) A horizontal, lateral force of 100,000 pounds applied at a point 30 inches up from the underframe

attachment, without exceeding the yield or the critical buckling stress; and

(3) A horizontal, longitudinal or lateral shear load of 150,000 pounds at its joint with the roof, without exceeding the ultimate strength of the joint.

(d) *Skin.* The skin covering the forward-facing end of each power car shall be:

(1) Equivalent to a 1/2-inch steel plate with a 25,000 pounds-per-square-inch yield strength—material of a higher yield strength may be used to decrease the required thickness of the material provided an equivalent level of strength is maintained.

(2) Securely attached to the end structure.

(3) Sealed to prevent the entry of fluids into the occupied cab area of the equipment.

BILLING CODE 4910-06-P

Power Car Control Cab Forward End Structure Conceptual Implementation

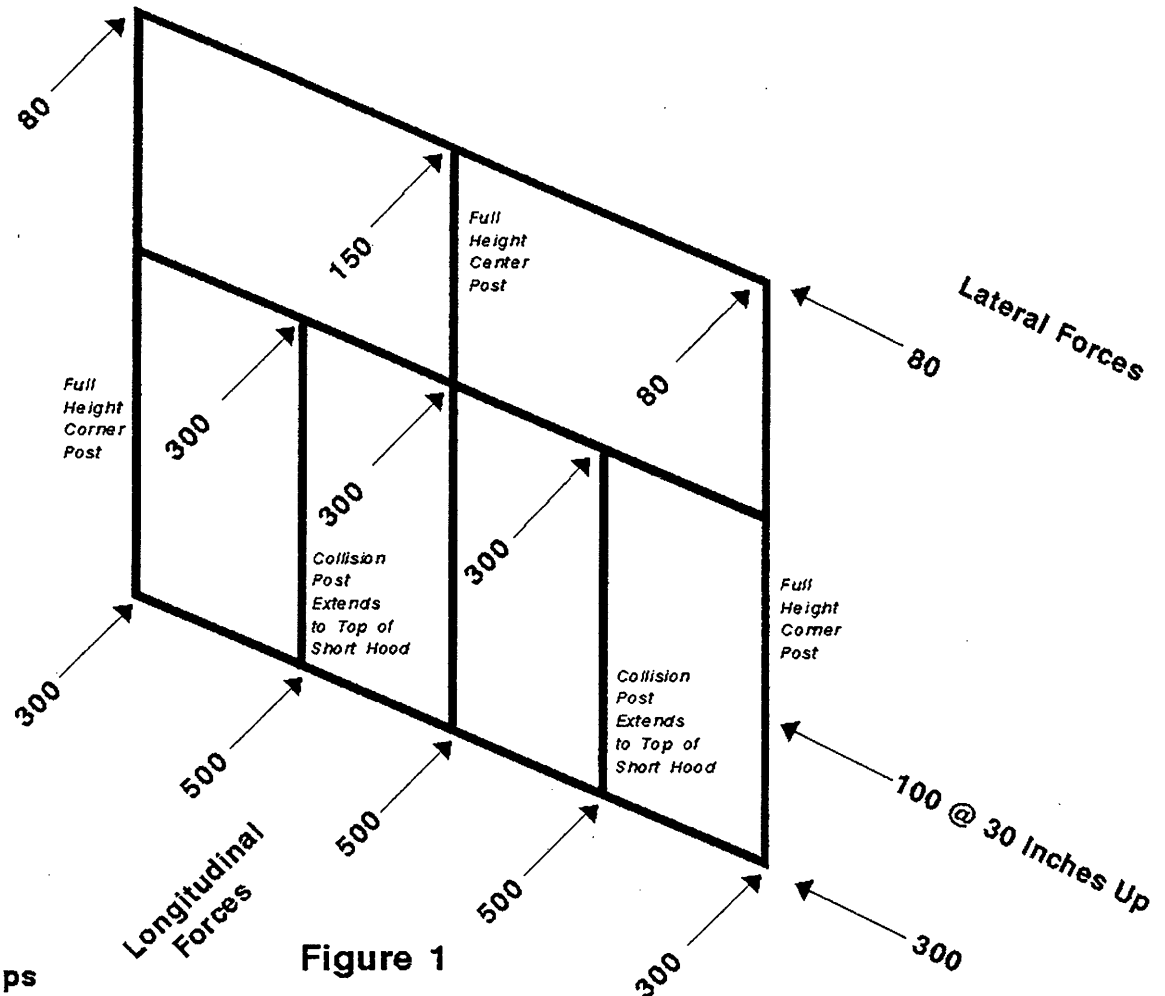

Figure 1

All Forces in Kips

BILLING CODE 4910-06-C

§ 238.411 Rear end structures of power car cabs.

This section contains design requirements for the rear end structure of the cab of a power car. (A conceptual implementation of this end structure is provided in Figure 2.)

(a) *Corner posts.* The rear end structure shall have two full-height corner posts, or their structural

equivalent, each capable of withstanding the following:

(1) A horizontal, longitudinal or lateral shear load of 300,000 pounds at its joint with the underframe without exceeding the ultimate strength of the joint; and

(2) A horizontal, longitudinal or lateral shear load of 80,000 pounds at its joint with the roof without exceeding the ultimate strength of the joint.

Collision posts. The rear end structure shall have two full-height collision

posts, or their structural equivalent, each capable of withstanding the following:

(1) A horizontal, longitudinal shear load of 750,000 pounds at its joint with the underframe without exceeding the ultimate strength of the joint; and

(2) A horizontal, longitudinal shear load of 75,000 pounds at its joint with the roof without exceeding the ultimate strength of the joint.

Power Car Control Cab Rear End Structure Conceptual Implementation

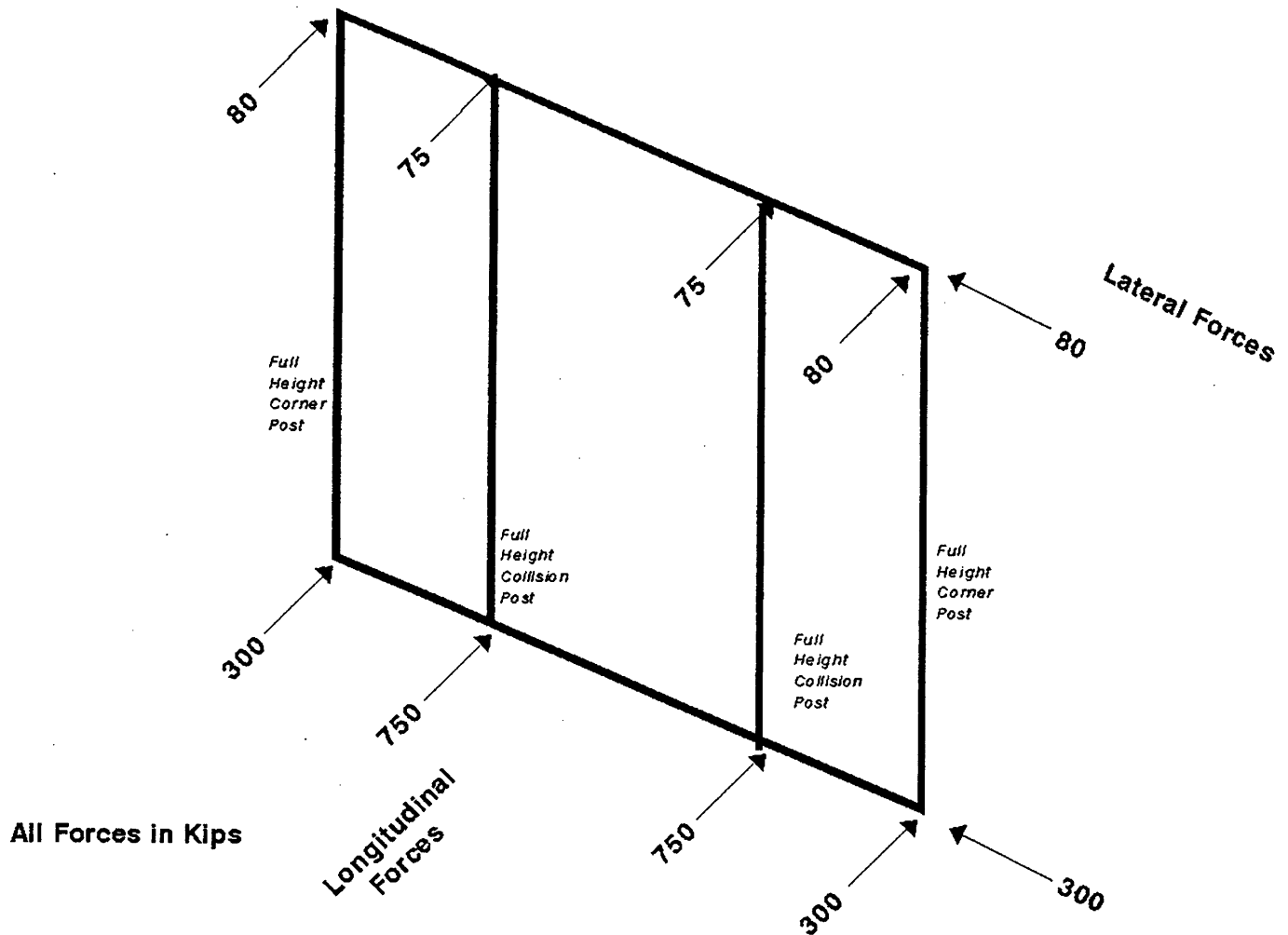

Figure 2

BILLING CODE 4910-06-C

§ 238.413 End structures of trailer cars.

(a) Except as provided in paragraphs (b) and (c) of this section, the end structure of a trailer car shall be designed to include the following elements, or their structural equivalent. (A conceptual implementation of this end structure is provided in Figure 3.)

(1) *Corner posts.* Two full-height corner posts, each capable of withstanding the following:

(i) A horizontal, longitudinal shear load of 150,000 pounds at its joint with the underframe without exceeding the ultimate strength of the joint;

(ii) A horizontal, longitudinal or lateral force of 30,000 pounds applied at a point 30 inches up from the

underframe attachment without exceeding the yield or the critical buckling stress; and

(iii) A horizontal, longitudinal or lateral shear load of 20,000 pounds at its joint with the roof without exceeding the ultimate strength of the joint.

(2) *Collision posts.* Two full-height collision posts each capable of withstanding the following:

(i) A horizontal, longitudinal shear load of 300,000 pounds at its joint with the underframe without exceeding the ultimate strength of the joint; and

(ii) A horizontal, longitudinal shear load of 60,000 pounds at its joint with the roof without exceeding the ultimate strength of the joint.

(b) If the trailer car consists of multiple articulated units not designed

for uncoupling other than in a maintenance shop, the end structure requirements of paragraph (a) of this section apply only to the ends of the entire car, not to the ends of each unit comprising the multi-unit car.

(c) If the trailer car is designed with a vestibule, the vestibule inboard end structure shall be designed with two full-height corner posts, or their structural equivalent, each capable of withstanding the following (A conceptual implementation of this end structure is provided in Figure 4.):

(1) A horizontal, longitudinal shear load of 200,000 pounds at its joint with the underframe without exceeding the ultimate strength of the joint;

(2) A horizontal, lateral force of 30,000 pounds applied at a point 30 inches up from the underframe attachment without exceeding the yield or the critical buckling stress;

(3) A horizontal, longitudinal force of 50,000 pounds applied at a point 30 inches up from the underframe attachment without exceeding the yield or the critical buckling stress; and

(4) A horizontal, longitudinal or lateral shear load of 20,000 pounds at its joint with the roof without exceeding the ultimate strength of the joint.

Trailer Car End Structure Conceptual Implementation

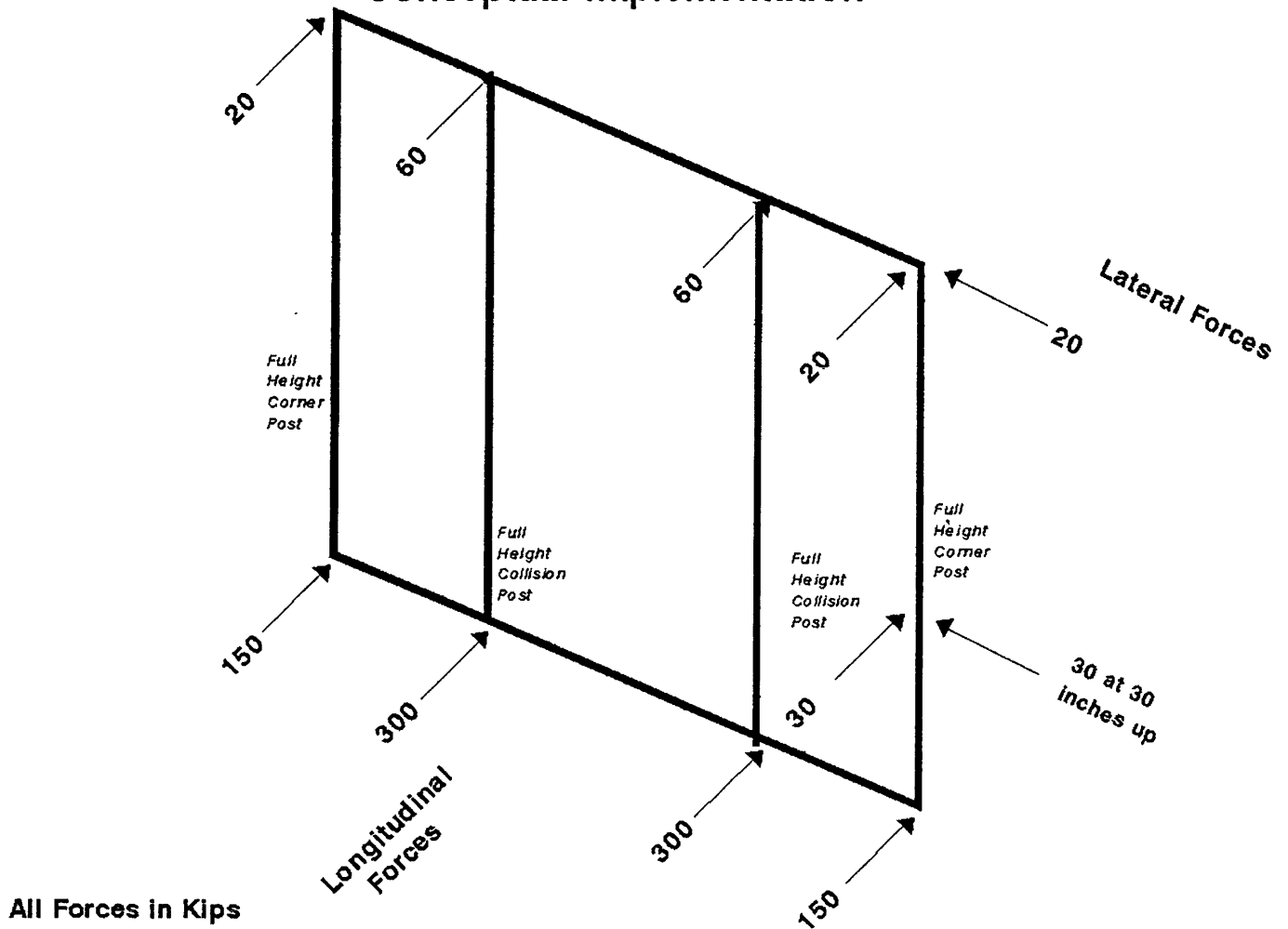

Figure 3

Trailer Car In-Board Vestibule End Structure Conceptual Implementation

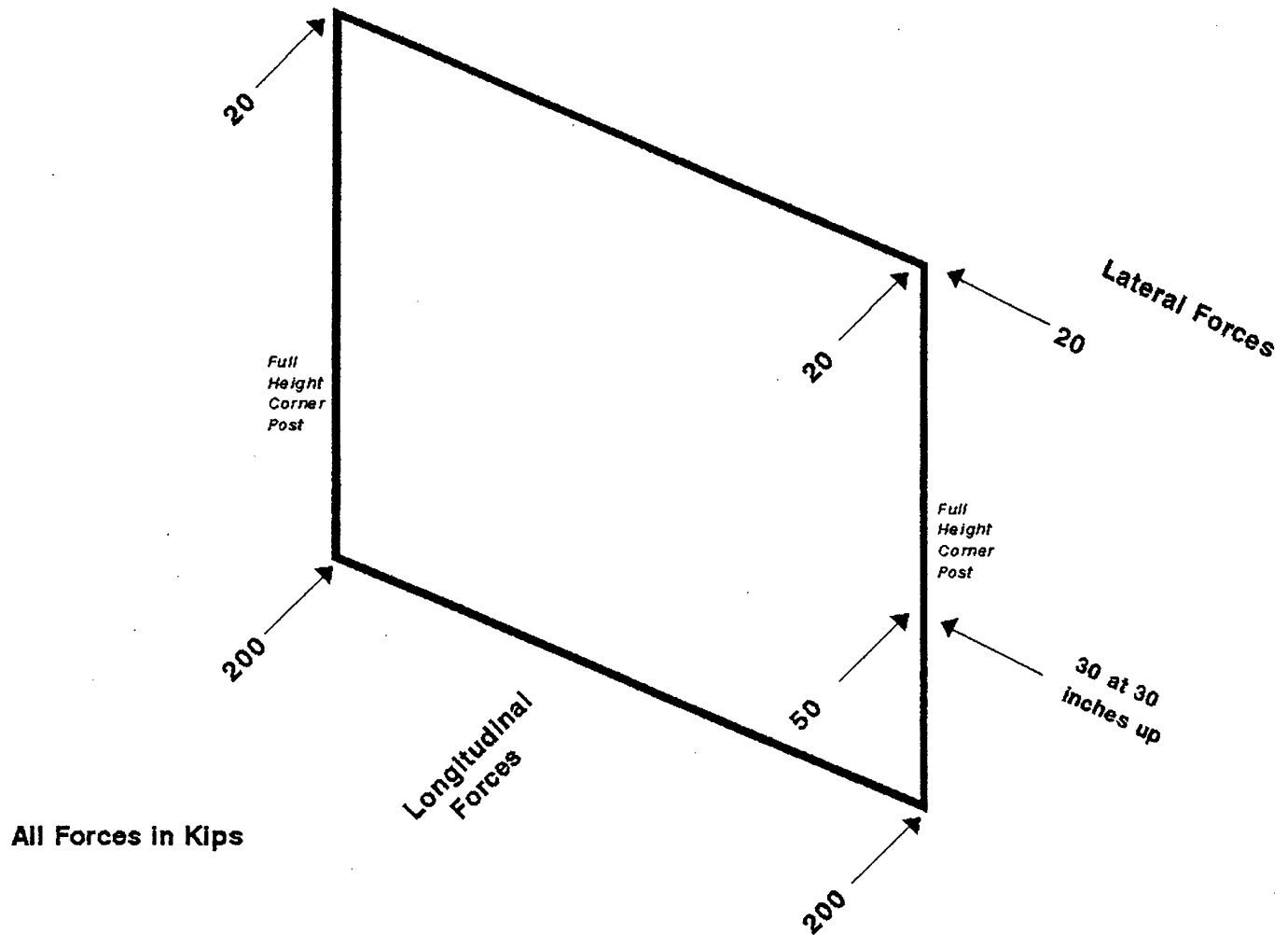

Figure 4

BILLING CODE 4910-06-C

§ 238.415 Rollover strength.

(a) Each power car shall be designed to rest on its side and be uniformly supported at the top ("roof rail") and the bottom ("side sill") chords of the side frame. The allowable stress for occupied volumes for this condition shall be one-half yield or one-half the critical buckling stress, whichever is less.

(b) Each passenger car and power car shall also be designed to rest on its roof so that any damage in occupied areas is limited to roof sheathing and framing. Deformation to the roof sheathing and framing is allowed to the extent necessary to permit the vehicle to be

supported directly on the top chords of the side frames and end frames. Other than roof sheathing and framing, the allowable stress for occupied volumes for this condition shall be one-half yield or one-half the critical buckling stress, whichever is less.

§ 238.417 Side loads.

(a) The single-level passenger car body structure shall be designed to resist an inward transverse load of 80,000 pounds of force applied to the side sill and 10,000 pounds of force applied to the belt rail (horizontal members at the bottom of the window opening in the side frame).

(b) These loads shall be considered to be applied separately over the full

vertical dimension of the specified member for a distance of 8 feet in the direction of the length of the car.

(c) The allowable stress shall be the lesser of the yield stress or the critical buckling stress with local yielding of the side skin allowed.

(d) The connections of the side frame to the roof and underframe shall support these loads.

§ 238.419 Truck-to-car-body and truck component attachment.

(a) The ultimate strength of the truck-to-car-body attachment for each unit in a train shall be sufficient to resist without failure a vertical force equivalent to 2g acting on the mass of the truck and a force of 250,000 pounds acting in any horizontal direction.

(b) Each component of a truck (which include axles, wheels, bearings, the truck-mounted brake system, suspension system components, and any other components attached to the truck by design) shall remain attached to the truck when a force equivalent to 2g acting on the mass of the component is exerted in any direction on that component.

§ 238.421 Glazing.

(a) Each power car and trailer car shall be equipped with certified glazing meeting the following requirements:

(1) End-facing exterior glazing shall resist the impact of a 12-pound solid steel sphere at the maximum speed at which the vehicle will operate, at an angle equal to the angle between the glazing surface as installed and the direction of travel, with no penetration or spall.

(2) Side-facing exterior glazing shall resist the impact of a:

(i) 12-pound solid steel sphere at 15 mph, at an angle of 90 degrees to the surface of the glazing, with no penetration or spall; and

(ii) A granite ballast stone weighing a minimum of 0.5 pounds, traveling at 75 mph and impacting at a 90-degree angle to the glazing surface, with no penetration or spall.

(3) All exterior glazing shall:

(i) Resist a single impact of a 9-mm, 147-grain bullet traveling at an impact velocity of 900 feet per second, with no bullet penetration or spall; and

(ii) Demonstrate anti-spalling performance by the use of a .001 aluminum witness plate, placed 12 inches from the glazing surface during all impact tests. The witness plate shall contain no marks from spalled glazing particles after any impact test.

(b) Each individual unit of glazing material shall be permanently marked, prior to installation, in such a manner that the marking is clearly visible after the material has been installed. The marking shall include:

(1) The words "FRA TYPE IH" for end-facing glazing or "FRA TYPE IHH" for side-facing glazing, to indicate that the material has successfully passed the testing requirements of paragraph (a) of this section;

(2) The name of the manufacturer; and

(3) The type or brand identification of the material.

(c) Glazing securement components shall hold the glazing in place against the forces described in paragraphs (a)(1) through (a)(3) of this section.

(d) Glazing securement components shall be designed to resist the forces due to air pressure differences caused when two trains pass at the minimum

separation for two adjacent tracks, while traveling in opposite directions, each train traveling at the maximum authorized speed.

(e) Interior equipment glazing shall meet the minimum requirements of AS1 type laminated glass as defined in American National Standard "Safety Code for Glazing Materials for Glazing Motor Vehicles Operating on Land Highways," ASA Standard Z26.1-1966.

(f) Each vehicle that is fully equipped with glazing materials that meet the requirements of paragraphs (a) through (e) of this section shall be stencilled on an interior wall as follows: "Fully Equipped with FRA Part 238 Glazing" or similar words conveying that meaning, in letters at least 3/8 of an inch high.

§ 238.423 Fuel tanks.

(a) *External fuel tanks.* (1) With all locomotive wheels resting on the ties beside the rail, the lowest point of an external fuel tank shall clear an 8½-inch combined height of the tie plate and rail by a minimum of 1½ inches. (This requirement results in a minimum 10-inch vertical distance from the lowest point on the wheel tread to the lowest point on the external fuel tank.)

(2) The end bulkheads of external fuel tanks shall at a minimum be equivalent to a 1-inch thick steel plate with a 25,000 pounds-per-square-inch yield strength—material of a higher yield strength may be used to decrease the required thickness of the material provided an equivalent level of strength is maintained.

(3) The skin of external fuel tanks shall at a minimum be equivalent to a ½-inch thick steel plate with a 25,000 pounds-per-square-inch yield strength—material of a higher yield strength may be used to decrease the required thickness of the material provided an equivalent level of strength is maintained.

(4) The material used for construction of external fuel tank exterior surfaces shall not exhibit a decrease in yield strength or penetration resistance in the temperature range of 0 to 160 degrees F.

(5) External fuel tank vent systems shall be designed to prevent them from becoming a path of fuel loss in the event a tank is placed in any orientation due to a locomotive overturning.

(6) The bottom surface of an external fuel tank shall be equipped with skid surfaces to prevent sliding contact with the rail or the ground from easily wearing through the tank.

(7) The structural strength of an external fuel tank shall be adequate to support 1½ times the dead weight of the

locomotive without deformation of the tank.

(b) *Internal fuel tanks.* (1) Internal fuel tanks shall have their lowest point at least 18 inches above the lowest point on the locomotive wheel tread and shall be enclosed by, or shall be part of, the locomotive structure.

(2) Internal fuel tank vent systems shall be designed to prevent them from becoming a path of fuel loss in the event a tank is placed in any orientation due to a locomotive overturning.

(3) Internal fuel tank bulkheads and skin shall at a minimum be equivalent to a 3/8-inch thick steel plate with a 25,000-pound yield strength—material of a higher yield strength may be used to decrease the required thickness of the material provided an equivalent level of strength is maintained. Skid plates are not required.

§ 238.425 Electrical system.

(a) *Circuit protection.* (1) The main propulsion power line shall be protected with a lightning arrestor, automatic circuit breaker, and overload relay. The lightning arrestor shall be run by the most direct path possible to ground with a connection to ground of not less than No. 6 AWG. These overload protection devices shall be housed in an enclosure designed specifically for that purpose with the arc chute vented directly to outside air.

(2) Head end power, including trainline power distribution, shall be provided with both overload and ground fault protection.

(3) Circuits used for purposes other than propelling the equipment shall be connected to their power source through circuit breakers or equivalent current-limiting devices.

(4) Each auxiliary circuit shall be provided with a circuit breaker located as near as practical to the point of connection to the source of power for that circuit; however, such protection may be omitted from circuits controlling safety-critical devices.

(b) *Main battery system.* (1) The main batteries shall be isolated from the cab and passenger seating areas by a non-combustible barrier.

(2) Battery chargers shall be designed to protect against overcharging.

(3) Battery circuits shall include an emergency battery cut-off switch to completely disconnect the energy stored in the batteries from the load.

(4) If batteries are of the type to potentially vent explosive gases, the batteries shall be adequately ventilated to prevent accumulation of explosive concentrations of these gases.

(c) *Power dissipation resistors.* (1) Power dissipating resistors shall be

adequately ventilated to prevent overheating under worst-case operating conditions.

(2) Power dissipation grids shall be designed and installed with sufficient isolation to prevent combustion between resistor elements and combustible material.

(3) Power dissipation resistor circuits shall incorporate warning or protective devices for low ventilation air flow, over-temperature, and short circuit failures.

(4) Resistor elements shall be electrically insulated from resistor frames, and the frames shall be electrically insulated from the supports that hold them.

(d) *Electromagnetic interference and compatibility.* (1) The operating railroad shall ensure electromagnetic compatibility of the systems critical to the safety of equipment with their environment. Electromagnetic compatibility can be achieved through equipment design or changes to the operating environment.

(2) The electronic equipment shall not produce electrical noise that interferes with trainline control and communications or with wayside signaling systems.

(3) To contain electromagnetic interference emissions, suppression of transients shall be at the source wherever possible.

(4) Electrical and electronic systems of equipment shall be capable of operation in the presence of external electromagnetic noise sources.

(5) All electronic equipment shall be self-protected from damage or improper operation, or both, due to high voltage transients and long-term over-voltage or under-voltage conditions.

§ 238.427 Suspension system.

(a) *General requirements.* (1) Suspension systems shall be designed to reasonably prevent wheel climb, wheel lift, rail rollover, rail shift, and a vehicle from overturning to ensure safe, stable performance and ride quality. These requirements shall be met in all operating environments, and under all track conditions and loading conditions as determined by the operating railroad. These requirements shall be met at all track speeds and over all track qualities of track consistent with the Track Safety Standards in part 213 of this chapter, up to the maximum operating speed and maximum cant deficiency of the equipment.

(2) Passenger equipment shall meet the safety performance standards for suspension systems contained in Appendix C to this part or alternative standards providing equivalent safety if

approved by the FRA Associate Administrator for Safety under the provisions of § 238.21.

(b) *Lateral accelerations.* Passenger cars shall not operate under conditions that result in a steady-state lateral acceleration of 0.1g (measured parallel to the car floor inside the passenger compartment) or greater.

(c) *Hunting oscillations.* Each truck shall be equipped with a permanently installed lateral accelerometer mounted on the truck frame. The accelerometer output signals shall be calibrated and filtered, and shall pass through signal conditioning circuitry designed to determine if hunting oscillations of the truck are occurring. If hunting oscillations are detected, the train monitoring system shall provide an alarm to the operator, and the train shall be slowed to a speed 5 mph less than the speed at which the hunting oscillations stopped.

(d) *Ride vibration (quality).* While traveling at the maximum operating speed over the intended route, the train suspension system shall be designed to:

(1) Limit the vertical acceleration, as measured by a vertical accelerometer mounted on the car floor, to no greater than 0.55g single event, peak-to-peak;

(2) Limit the lateral acceleration, as measured by a lateral accelerometer mounted on the car floor, to no greater than 0.3g single event, peak-to-peak; and

(3) Limit the combination of lateral acceleration (L) and vertical acceleration (V) occurring within any time period of 2 consecutive seconds as expressed by the square root of $(V^2 + L^2)$ to no greater than 0.604, where L may not exceed 0.3g and V may not exceed 0.55g.

(e) *Compliance.* Compliance with the requirements contained in paragraph (d) of this section shall be demonstrated during the equipment pre-revenue service acceptance tests required under § 238.113 and [proposed] § 213.345 of this chapter.

(f) *Overheat sensors.* Overheat sensors for each equipment bearing shall be provided. The sensors may be on board or placed at reasonable wayside intervals.

§ 238.429 Safety appliances.

(a) *Couplers.* (1) The leading and the trailing ends of semi-permanently coupled trainsets shall be equipped with an automatic coupler that couples on impact and uncouples by either activation of a traditional uncoupling lever or some other type of uncoupling mechanism that does not require a person to go between the equipment units.

(2) Automatic couplers and uncoupling devices on the leading and trailing ends of semi-permanently coupled trainsets may be stored within a removable shrouded housing.

(3) If the units in a train are not semi-permanently coupled, both ends of each unit shall be equipped with an automatic coupler, that couples on impact and uncouples by either activation of a traditional uncoupling lever or some other type of uncoupling mechanism that does not require a person to go between the equipment units.

(b) *Hand brakes.* Except as provided in paragraph (f) of this section, Tier II trains shall be equipped with a parking or hand brake that can be applied and released manually that is capable of holding the train on a 3-percent grade.

(c) Safety appliance mechanical strength and fasteners.

(1) All handrails, handholds, and sill steps shall be made of 1-inch diameter steel pipe or 5/8-inch thickness steel or a material of equal or greater mechanical strength.

(2) All safety appliances shall be securely fastened to the car body structure with mechanical fasteners that have mechanical strength greater than or equal to that of a 1/2-inch diameter SAE steel bolt mechanical fastener.

(i) Safety appliance mechanical fasteners shall have mechanical strength and fatigue resistance equal to or greater than a 1/2-inch diameter SAE steel bolt.

(ii) Mechanical fasteners shall be installed with a positive means to prevent unauthorized removal. Self-locking threaded fasteners do not meet this requirement.

(iii) Mechanical fasteners shall be installed to facilitate inspection.

(d) *Handrails and handholds.* Except as provided in paragraph (f) of this section:

(1) Handrails shall be provided for passengers on both sides of all steps used to board or depart the train.

(2) Exits on a power vehicle shall be equipped with handrails and handholds so that crewmembers can get on and off the vehicle safely.

(3) Throughout their entire length, handrails and handholds shall be a contrasting color to the surrounding vehicle body.

(4) The maximum distance above the top of the rail to the bottom of vertical handrails and handholds shall be 51 inches and the minimum distance shall be 21 inches.

(5) Vertical handrails and handholds shall be installed to continue to a point at least equal to the height of the top edge of the control cab door.

(6) The minimum hand clearance distance between a vertical handrail or handhold and the vehicle body shall be 2½ inches for the entire length.

(7) All vertical handrails and handholds shall be securely fastened to the vehicle body.

(8) If the length of the handrail exceeds 60 inches, it shall be securely fastened to the power vehicle body with two fasteners at each end.

(e) *Sill steps.* Except as provided in paragraph (f) of this section:

(1) Each power vehicle shall be equipped with a sill step below each exterior door as follows:

(i) The sill step shall have a minimum cross-sectional area of ½ by 3 inches.

(ii) The sill step shall be made of steel or a material of equal or greater strength and fatigue resistance.

(iii) The minimum tread length of the sill step shall be 10 inches.

(iv) The minimum clear depth of the sill step shall be 8 inches.

(v) The outside edge of the tread of the sill step shall be flush with the side of the car body structure.

(vi) Sill steps shall not have a vertical rise between treads exceeding 18 inches.

(vii) The lowest sill step tread shall be not more than 20 inches above the top of the track rail.

(viii) Sill steps shall be a color which contrasts with the surrounding power vehicle body color.

(ix) Sill steps shall be securely fastened.

(x) At least 50 percent of the tread surface area of each sill step shall be open space.

(xi) The portion of the tread surface area of each sill step which is not open space and is normally contacted by the foot shall be treated with an anti-skid material.

(f) Exceptions.

(1) If the units of the equipment are semi-permanently coupled, with uncoupling done only at maintenance facilities, the equipment units that are not required by paragraph (a) of this section to be equipped with automatic couplers need not be equipped with sill steps or end or side handholds that would normally be used to safely perform coupling and uncoupling operations.

(2) If the units of the equipment are not semi-permanently coupled, the units shall be equipped with hand brakes, sill steps, end handholds, and side handholds that meet the requirements contained in § 231.14 of this chapter.

(3) If two trainsets are coupled to form a single train that is not semi-permanently coupled (i.e., that is coupled by an automatic coupler), the

automatically coupled ends shall be equipped with hand brakes, sill steps, end handholds, and side handholds that meet the requirements contained in § 231.14 of this chapter. If the trainsets are semi-permanently coupled, these safety appliances are not required.

(g) *Optional safety appliances.* Safety appliances installed at the option of the railroad shall be firmly attached with mechanical fasteners and shall meet the design and installation requirements provided in this section.

§ 238.431 Brake system.

(a) A passenger train's brake system shall be capable of stopping the train from its maximum operating speed within the signal spacing existing on the track over which the train is operating under worst-case adhesion conditions.

(b) The brake system shall be designed to allow an inspector to determine that the brake system is functioning properly without having to place himself or herself in a dangerous position on, under, or between the equipment.

(c) Passenger equipment shall be provided with an emergency application feature that produces an irretrievable stop, using a brake rate consistent with prevailing adhesion, passenger safety, and brake system thermal capacity. An emergency application shall be available at any time, and shall be initiated by an unintentional parting of the train. A means to initiate an emergency brake application shall be provided at two locations in each unit of the train.

(d) The brake system shall be designed to prevent thermal damage to wheels and brake discs. The operating railroad shall demonstrate through analysis and test that no thermal damage results to the wheels or brake discs under conditions resulting in maximum braking effort being exerted on the wheels or discs.

(e) The following requirements apply to blended braking systems:

(1) Loss of power or failure of the dynamic brake does not result in exceeding the allowable stop distance;

(2) The friction brake alone is adequate to safely stop the train under all operating conditions;

(3) The operational status of the electric portion of the brake system shall be displayed for the train operator in the control cab; and

(4) The operating railroad shall demonstrate through analysis and testing the maximum operating speed for safe operation of the train using only the friction brake portion of the blended brake with no thermal damage to wheels or discs.

(f) The brake system design shall allow a disabled train's pneumatic brakes to be controlled by a conventional locomotive, during rescue operation, through brake pipe control alone.

(g) An independent failure-detection system shall compare brake commands with brake system output to determine if a failure has occurred. The failure detection system shall report brake system failures to the automated train monitoring system.

(h) Passenger equipment shall be provided with an adhesion control system designed to automatically adjust the braking force on each wheel to prevent sliding during braking. In the event of a failure of this system to prevent wheel slide within preset parameters, a wheel slide alarm that is visual or audible, or both, shall alert the train operator in the cab of the controlling power car to wheel-slide conditions on any axle of the train.

§ 238.433 Draft system.

(a) Leading and trailing automatic couplers of trains shall be compatible with standard AAR couplers with no special adapters used.

(b) All passenger equipment continues to be subject to the requirements concerning couplers and uncoupling devices contained in Federal Statute at 49 U.S.C. chapter 203 and in FRA regulations at part 231 and § 232.2 of this chapter.

§ 238.435 Interior fittings and surfaces.

(a) The seat back in a passenger car shall be designed to withstand, with deflection but without total failure, the load of a seat occupant who is a 95th-percentile male accelerated at 8g impacting the seat back.

(b) The seat back in a passenger car shall include shock-absorbent material to cushion the impact of occupants with the seat ahead of them.

(c) The ultimate strength of a seat attachment to a passenger car body shall be of sufficient strength to withstand the following individually applied accelerations acting on the mass of the seat plus the mass of a seat occupant who is a 95th-percentile male:

(1) Longitudinal: 8g;

(2) Lateral: 4g; and

(3) Vertical: 4g.

(d) Other interior fittings shall be attached to the passenger car body with sufficient strength to withstand the following individually applied accelerations acting on the mass of the fitting:

(1) Longitudinal: 8g;

(2) Lateral: 4g; and

(3) Vertical: 4g.

Fittings that can be expected to be impacted by a person during a collision, such as tables between facing seats, shall be designed for the mass of the fitting plus the mass of the number of occupants who are 95th-percentile males that could be expected to strike the fitting.

(e) The ultimate strength of the interior fittings and equipment in power car control cabs shall be sufficient to resist without failure loads due to the following individually applied accelerations acting on the mass of the fitting or equipment:

- (1) Longitudinal: 12g;
- (2) Lateral: 4g; and
- (3) Vertical: 4g.

(f) To the extent possible, interior fittings, except seats, shall be recessed or flush-mounted. Corners and sharp edges shall be avoided or otherwise padded.

(g) Energy-absorbent material shall be used to pad surfaces likely to be impacted by occupants during collisions or derailments.

(h) Luggage stowage compartments shall be of the enclosed, aircraft type with ultimate strength sufficient to resist loads due to the following individually applied accelerations acting on the mass of the luggage that the compartments are designed to accommodate:

- (1) Longitudinal: 8g;
- (2) Lateral: 4g; and
- (3) Vertical: 4g.

§ 238.437 Emergency communication.

A means of emergency communication throughout a train shall be provided and shall include the following:

(a) Transmission locations that are clearly marked with luminescent material at each end of each unit adjacent to the unit end doors;

(b) Clear and understandable operating instructions at or near each transmission location; and

(c) Back-up power for a minimum time period of two hours.

§ 238.439 Emergency window exits and roof hatches.

(a) *Emergency window exits.* Except as provided in paragraphs (a)(3) and (a)(4) of this section, each passenger car shall have a minimum of four emergency window exits, either in a staggered configuration or with one located at each end of each side of a passenger car.

(1) Each sealed emergency window exit on a passenger coach shall have a minimum free opening of 30 inches horizontally by 30 inches vertically.

(2) Each emergency window exit shall be easily operable by a 5th-percentile

female without requiring the use of a tool or other implement.

(3) If the passenger car is bi-level, each main level shall have a minimum of four emergency window exits, either in a staggered configuration or with one located at each end of each side on each level.

(4) Each passenger car of special design, such as a sleeping car, shall have at least one emergency window exit in each compartment.

(b) *Roof hatches.* (1) Each power car cab shall have a minimum of one roof hatch emergency entrance location with either a minimum opening of 18 inches by 24 inches or a clearly marked structural weak point in the roof to provide a minimum opening of the same dimensions to provide quick access for properly equipped emergency personnel.

(2) Each passenger car shall be equipped with a minimum of two roof hatch emergency entrance locations with either a minimum opening of 18 inches by 24 inches or two clearly marked structural weak points in the roof to provide a minimum opening of the same dimensions to provide quick access for properly equipped emergency personnel.

(c) *Marking and instructions.*
[Reserved]

§ 238.441 Doors.

(a) Each passenger car shall have a minimum of four side doors, or the functional equivalent of four side doors, each permitting at least one 95th-percentile male to pass through at a single time.²

(1) Each powered, exterior side door shall be equipped with a manual override that is:

(i) Capable of opening the door without power from both inside and outside the car;

(ii) Located adjacent to the door which it controls; and

(iii) Designed and maintained so that a person may access the override device from both inside and outside the car without the use of any tool or other implement.

(2) The status of each powered, exterior side door shall be displayed to the crew in the operating cab. If door interlocks are used, the sensors used to detect train motion shall be nominally set to operate at 3 mph.

(b) Each powered, exterior side door shall be connected to an emergency back-up power system.

² The Americans with Disabilities Act (ADA) Accessibility Specifications for Transportation Vehicles also contain requirements for doorway clearance (See Title 49 Code of Federal Regulations Part 38).

(c) A railroad may protect a manual override device used to open a powered, exterior door with a cover or a screen capable of removal by a 5th-percentile female without requiring the use of a tool or other implement. If the method of removing the protective cover or screen entails breaking or shattering it, the cover or screen shall be scored, perforated, or otherwise weakened so that a 5th-percentile female can penetrate the cover or screen with a single blow of her fist without injury to her hand.

(d) Passenger compartment end doors shall be equipped with a kick-out panel, pop-out window, or other similar means of egress in the event the door will not open.

(e) *Marking and instructions.*
[Reserved]

§ 238.443 Headlights.

Each power car shall be equipped with at least two headlights. Each headlight shall produce no less than 200,000 candela. One headlight shall be focused to illuminate a person standing between the rails at 800 feet under clear weather conditions. The other headlight shall be focused to illuminate a person standing between the rails at 1500 feet under clear weather conditions.

§ 238.445 Automated monitoring.

(a) Each passenger train shall be equipped to monitor the performance of the following systems or components:

- (1) Reception of cab signals and train control signals;
- (2) Truck hunting;
- (3) Dynamic brake status;
- (4) Friction brake status;
- (5) Fire detection systems;
- (6) Head end power status;
- (7) Alerter or deadman control;
- (8) Horn and bell;
- (9) Wheel slide;
- (10) Tilt system, if so equipped; and
- (11) On-board bearing-temperature sensors, if so equipped.

(b) The operator shall be alerted when any of the monitored parameters are out of predetermined limits. In situations where the system safety analysis indicates that operator-reaction time is crucial to safety, immediate automatic corrective action such as limiting the speed of the train shall be taken.

(c) The monitoring system shall be designed with an automatic self-test feature that notifies the operator that the monitoring capability is functioning correctly and alerts the operator that a system failure has occurred.

§ 238.447 Operator's controls and cab layout.

(a) Operator controls in the power vehicle or control cab shall be arranged

to be comfortably within view and within easy reach when the operator is seated in the normal train control position.

(b) The control panels shall be laid out to minimize the chance of human error.

(c) Control panel buttons, switches, levers, knobs, and the like shall be distinguishable by sight and by touch.

(d) An alerter shall be provided. If not acknowledged, the alerter shall cause a brake application to stop the train.

(e) Cab information displays shall be designed with the following characteristics:

(1) Simplicity and standardization shall be the driving criteria for design of formats for the display of information in the cab;

(2) Essential, safety-critical information shall be displayed as a default condition;

(3) Operator selection shall be required to display other than default information;

(4) Cab or train control signals shall be displayed for the operator; and

(5) Displays shall be readable from the operators' normal position under all lighting conditions.

(f) The cab layout shall be arranged to meet the following requirements:

(1) The crew has an effective field of view in the forward direction and to the right and left of the direction of travel;

(2) Field-of-view obstructions due to required structural members are minimized; and

(3) The crew's position in the cab is located to permit the crew to be able to directly observe traffic approaching the train from either side of the train.

(g) Each seat provided for a crewmember shall be:

(1) Equipped with a single acting, quick-release lap belt and shoulder harness as defined in § 571.209 of this title;

(2) Secured to the car body with an attachment having an ultimate strength capable of withstanding the loads due to the following individually applied accelerations acting on the mass of the seat and the crewmember occupying it:

(i) Longitudinal: 12g;

(ii) Lateral: 4g; and

(iii) Vertical: 4g;

(3) Designed so all adjustments have the range necessary to accommodate a 5th-percentile female to a 95th-percentile male;

(4) Equipped with lumbar support that is adjustable from the seated position;

(5) Equipped with force-assisted, vertical-height adjustment, operated from the seated position;

(6) Equipped with a manually reclining seat back, adjustable from the seated position;

(7) Equipped with an adjustable headrest; and

(8) Equipped with folding, padded armrests.

(h) Sharp edges and corners shall be eliminated from the interior of the cab, and interior surfaces of the cab likely to be impacted by a crewmember during a collision or derailment shall be padded with shock-absorbent material.

Subpart F—Inspection, Testing, and Maintenance Requirements for Tier II Passenger Equipment

§ 238.501 Scope.

This subpart contains inspection, testing, and maintenance requirements for railroad passenger equipment that operates at speeds exceeding 125 mph but not exceeding 150 mph.

§ 238.503 Inspection, testing, and maintenance requirements.

(a) *General.* Under the procedures provided in § 238.505, each railroad shall obtain FRA approval of a written inspection, testing, and maintenance program for Tier II passenger equipment prior to implementation of that program and prior to commencing passenger operations using that equipment. As further specified in this section, the program shall describe in detail the procedures, equipment, and other means necessary for the safe operation of the passenger equipment, including:

(1) Safety inspection procedures, intervals, and criteria;

(2) Testing procedures and intervals;

(3) Scheduled preventive-maintenance intervals;

(4) Maintenance procedures;

(5) Special testing equipment or measuring devices required to perform safety inspections and tests; and

(6) The training, qualification, and designation of employees and contractors to perform safety inspections, tests, and maintenance.

(b) *Compliance.* After the railroad's inspection, testing, and maintenance program is approved by FRA under § 238.505, the railroad shall adopt the program and shall perform—

(1) The inspections and tests of power brakes and other primary brakes as described in the program;

(2) The other inspections and tests described in the program in accordance with the procedures and criteria that the railroad identified as safety-critical; and

(3) The maintenance tasks described in the program in accordance with the procedures and intervals that the railroad identified as safety-critical.

(c) *General safety inspection, testing, and maintenance procedures.* The inspection, testing, and maintenance program under paragraph (a) of this section shall contain the railroad's written procedures to ensure that all systems and components of in service equipment are free of any general condition that endangers the safety of the crew, passengers, or equipment. These procedures shall protect against:

(1) A continuous accumulation of oil or grease;

(2) Improper functioning of a component;

(3) A crack, break, excessive wear, structural defect, or weakness of a component;

(4) A leak;

(5) Use of a component or system under a condition that exceeds that for which the component or system is designed to operate; and

(6) Insecure attachment of a component.

(d) *Specific safety inspections.* The program under paragraph (a) of this section shall specify that all Tier II passenger equipment shall receive thorough safety inspections in accordance with the following standards:

(1) Except as provided in paragraph (d)(3) of this section, the equivalent of a Class I brake test contained in § 238.313 shall be conducted prior to a train's departure from an originating terminal and every 1,500 miles or once each calendar day, whichever comes first, that the train remains in continuous service.

(i) Class I equivalent brake tests shall be performed by qualified mechanical inspectors.

(ii) Except as provided in § 238.15(b), a railroad shall not use or haul a Tier II passenger train in passenger service from a location where a Class I equivalent brake test has been performed, or was required by this part to have been performed, with less than 100 percent operative brakes.

(2) Except as provided in paragraph (d)(3) of this section, a complete safety exterior and interior mechanical inspection, in accordance with the railroad's inspection program, shall be conducted by qualified mechanical inspectors at least once during each calendar day the equipment is used in service.

(3) Trains that miss a scheduled Class I brake test or mechanical inspection due to a delay en route may proceed to the point where the Class I brake test or mechanical inspection was scheduled to be performed.

(e) *Movement of trains with power brake defects.* Movement of trains with

a power brake defect as defined in § 238.15 (any primary brake defect) shall be governed by § 238.15.

(f) *Movement of trains with other defects.* Movement of trains that with a defect other than a power brake defect shall be conducted in accordance with § 238.17, with the following exception. When a failure of the secondary brake on a Tier II passenger train occurs en route, that train may remain in service until its next scheduled calendar day Class I brake test equivalent at a speed no greater than the maximum safe operating speed demonstrated through analysis and testing for braking with the friction brake alone. The brake system shall be restored to 100 percent operation before the train departs that inspection location.

(g) *Maintenance intervals.* The program under paragraph (a) of this section shall include the railroad's initial scheduled maintenance intervals for Tier II equipment based on an analysis completed as part of the system safety program. The maintenance interval of a safety-critical component shall be changed only when justified by accumulated, verifiable operating data and approved by FRA's Associate Administrator for Safety under § 238.505 before the change takes effect.

(h) *Training, qualification, and designation program.* The program under paragraph (a) of this section shall describe the training, qualification, and designation program, as defined in the training program plan under § 238.111, established by the railroad to qualify individuals to inspect, test, and maintain the equipment.

(1) If the railroad deems it safety-critical, then only qualified individuals shall inspect, test, and maintain the equipment.

(2) Knowledge of the standard procedures described in paragraph (i) of this section shall be required to qualify an employee or contractor to perform an inspection, testing, or maintenance task under this part.

(i) *Standard procedures for safely performing inspection, testing, maintenance, or repairs.* The program under paragraph (a) of this section shall include the railroad's written standard procedures for performing all safety-critical equipment inspection, testing, maintenance, or repair tasks. These standard procedures shall:

(1) Describe in detail each step required to safely perform the task;

(2) Describe the knowledge necessary to safely perform the task;

(3) Describe any precautions that must be taken to safely perform the task;

(4) Describe the use of any safety equipment necessary to perform the task;

(5) Be approved by the railroad's chief mechanical officer;

(6) Be approved by the railroad's official responsible for safety;

(7) Be enforced by supervisors with responsibility for accomplishing the tasks; and

(8) Be reviewed annually by the railroad.

(j) *Quality control program.* Each railroad shall establish an inspection, testing, and maintenance quality control program enforced by railroad or contractor supervisors to reasonably ensure that inspections, tests, and maintenance are performed in accordance with Federal safety standards and the procedures established by the railroad.

(k) *Identification of safety-critical items.* In the program under paragraph (a) of this section, the railroad shall identify all inspection and testing procedures and criteria as well as all maintenance intervals that the railroad deems to be safety-critical.

§ 238.505 Program approval procedure.

(a) *Submission.* Not less than 90 days prior to commencing passenger operations using Tier II passenger equipment, each railroad to which this subpart applies shall submit for approval an inspection, testing, and maintenance program for that equipment meeting the requirements of this subpart with the Associate Administrator for Safety, Federal Railroad Administration, 400 7th Street, S.W., Washington, D.C. 20590. If a railroad seeks to amend an approved program, the railroad shall file with FRA's Associate Administrator for Safety a petition for approval of such amendment not less than 60 days prior to the proposed effective date of the amendment. A program responsive to the requirements of this subpart or any amendment to the program shall not be implemented prior to FRA approval.

(1) Each program or amendment under § 238.503 shall contain:

(i) The information prescribed in § 238.503 for such program or amendment;

(ii) The name, title, address, and telephone number of the primary person to be contacted with regard to review of the program or amendment; and

(iii) A statement affirming that the railroad has served a copy of the program or amendment on designated representatives of railroad employees, together with a list of the names and addresses of persons served.

(2) Each railroad shall serve a copy of each submission to FRA on designated representatives of railroad employees responsible for the equipment's operation, inspection, testing, and maintenance under this subpart.

(b) *Comment.* Not later than 45 days from the date of filing the program or amendment, any person may comment on the program or amendment.

(1) Each comment shall set forth specifically the basis upon which it is made, and contain a concise statement of the interest of the commenter in the proceeding.

(2) Three copies of each comment shall be submitted to the Associate Administrator for Safety, Federal Railroad Administration, 400 7th Street, S.W., Washington, D.C. 20590.

(3) The commenter shall certify that a copy of the comment was served on the railroad.

(c) *Approval.* (1) Within 60 days of receipt of each initial inspection, testing, and maintenance program, FRA will conduct a formal review of the program. FRA will then notify the primary railroad contact person and the designated employee representatives in writing whether the inspection, testing, and maintenance program is approved and, if not approved, the specific points in which the program is deficient. If a program is not approved by FRA, the railroad shall amend its program to correct all deficiencies and resubmit its program with the required revisions not later than 45 days prior to commencing passenger operations.

(2) FRA will review each proposed amendment to the program within 45 days of receipt. FRA will then notify the primary railroad contact person and the designated employee representatives in writing whether the proposed amendment has been approved by FRA and, if not approved, the specific points in which the proposed amendment is deficient. The railroad shall correct any deficiencies and file the corrected amendment prior to implementing the amendment.

(3) Following initial approval of a program or amendment, FRA may reopen consideration of the program or amendment for cause stated.

Subpart G—Introduction of New Technology to Tier II Passenger Equipment

§ 238.601 Scope.

This subpart contains general requirements for introducing new technology that affects a safety system of existing Tier II passenger equipment. For purposes of this subpart, "existing Tier II passenger equipment" is Tier II

passenger equipment that has been approved for revenue service by the FRA Associate Administrator for Safety under the procedures of § 238.21.

§ 238.603 Process to introduce new technology.

(a) If a railroad plans a major upgrade or introduction of new technology on existing Tier II passenger equipment, as defined in § 238.601, that affects the performance of a safety system on such equipment, such major upgrade or introduction of new technology shall be designed and implemented using the system safety process prescribed in § 238.101.

(b) Under the procedures of § 238.21, each railroad shall obtain special approval from the FRA Associate Administrator for Safety of a pre-revenue service acceptance testing plan, under § 238.113, for existing Tier II passenger equipment with a major upgrade or new technology that affects the performance of a safety system on such equipment, prior to implementing the plan. "New passenger equipment," for purposes of § 238.113, includes existing Tier II passenger equipment with such a major upgrade or new technology.

(c) Each railroad shall complete a pre-revenue service demonstration of such passenger equipment described in paragraph (b) of this section in accordance with the approved plan, shall fulfill all of the other requirements prescribed in § 238.113, and shall obtain special approval from the FRA Associate Administrator for Safety under the procedures of § 238.21 prior to using such passenger equipment in revenue service.

Appendix A to Part 238—Schedule of Civil Penalties [Reserved]

Appendix B to Part 238—Test Performance Criteria for the Flammability and Smoke Emission Characteristics of Materials Used in Constructing or Refurbishing Locomotive Cab and Passenger Car Interiors

This appendix provides the performance standards for testing the flammability and smoke emission characteristics of materials used in constructing or refurbishing locomotive cab and passenger car interiors, in accordance with the requirements of § 238.115.

(a) *Definitions.*

Critical radiant flux (CRF) means, as defined in ASTM E-648, a measure of the

behavior of horizontally-mounted floor covering systems exposed to a flaming ignition source in a graded radiant heat energy environment in a test chamber.

Flame spread index (I_s) means, as defined in ASTM E-162, a factor derived from the rate of progress of the flame front (F_s) and the rate of heat liberation by the material under test (Q), such that I_s = F_s × Q.

Specific optical density (D_s) means, as defined in ASTM E-662, the optical density measured over unit path length within a chamber of unit volume, produced from a specimen of unit surface area, that is irradiated by a heat flux of 2.5 watts/cm² for a specified period of time.

Surface flammability means the rate at which flames will travel along surfaces.

Flaming running means continuous flaming material leaving the site of material burning or material installation.

Flaming dripping means periodic dripping of flaming material from the site of material burning or material installation.

(b) *Required test procedures and performance criteria.*

The materials used in locomotive cabs and passenger cars shall be tested according to the procedures and performance criteria set forth in the following table. In all instances, the most recent version of the test procedures or the revision in effect at the time a vehicle is ordered should be employed in the evaluation of the materials specified.

Category	Function of material	Test procedure	Performance criteria
Passenger seats, Sleeping and dining car components.	Cushions, Mattresses ^{1, 2, 5, 9}	ASTM D-3675 ASTM E-662	I _s ≤ 25 D _s (1.5) ≤ 100; D _s (4.0) ≤ 175
	Seat and/or Mattress Frame ^{1, 5, 8}	ASTM E-162 ASTM E-662	I _s ≤ 35 D _s (1.5) ≤ 100; D _s (4.0) ≤ 200
	Seat and Toilet Shroud, Food Trays ^{1, 5}	ASTM E-162 ASTM E-662	I _s ≤ 35 D _s (1.5) ≤ 100; D _s (4.0) ≤ 200
	Seat Upholstery, Mattress Ticking and Covers, Curtains ^{1, 2, 3, 5}	FAR 25.853 (Vertical) ASTM E-662	Flame Time ≤ 10 sec.; Burn length ≤ 6 inch D _s (4.0) ≤ 250 coated; D _s (4.0) ≤ 100 uncoated
Panels	Wall ^{1, 5, 10}	ASTM E-162 ASTM E-662	I _s ≤ 35 D _s (1.5) ≤ 100; D _s (4.0) ≤ 200
	Ceiling ^{1, 5, 10}	ASTM E-162 ASTM E-662	I _s ≤ 35 D _s (1.5) ≤ 100; D _s (4.0) ≤ 200
	Partition, Tables and Shelves ^{1, 5}	ASTM E-162 ASTM E-662	I _s ≤ 35 D _s (1.5) ≤ 100; D _s (4.0) ≤ 200
	Windscreen ^{1, 5}	ASTM E-162 ASTM E-662	I _s ≤ 35 D _s (1.5) ≤ 100; D _s (4.0) ≤ 200
	HVAC Ducting ^{1, 5}	ASTM E-162 ASTM E-662	I _s ≤ 35 D _s (1.5) ≤ 100
	Window ^{4, 5}	ASTM E-162 ASTM E-662	I _s ≤ 100 D _s (1.5) ≤ 100; D _s (4.0) ≤ 200
	Light Diffuser ⁵	ASTM E-162 ASTM E-662	I _s ≤ 100 D _s (1.5) ≤ 100; D _s (4.0) ≤ 200
Flooring	Structural ⁶	ASTM E-119	Pass
	Covering ^{7, 10}	ASTM E-648 ASTM E-662	CRF ≤ 0.5 w/cm ² D _s (1.5) ≤ 100; D _s (4.0) ≤ 200
Insulation	Thermal ^{1, 2, 5}	ASTM E-162 ASTM E-662	I _s ≤ 25 D _s (1.5) ≤ 100
	Acoustic ^{1, 2, 5}	ASTM E-162 ASTM E-662	I _s ≤ 25 D _s (1.5) ≤ 100
	Elastomers	Window Gaskets, Door Nosing, Diaphragms, Roof Mat. ¹	ASTM C-542 ASTM E-662
Exterior Plastic Components	End Cap, Roof Housings ^{1, 5}	ASTM E-162 ASTM E-662	I _s ≤ 35 D _s (1.5) ≤ 100; D _s (4.0) ≤ 200

Category	Function of material	Test procedure	Performance criteria
Component Box Covers	Interior, Exterior Boxes ^{1, 3, 5}	ASTM E-162 ASTM E-662	I _s ≤ 35 D _s (1.5) ≤ 100; D _s (4.0) ≤ 200

1. Materials tested for surface flammability must not exhibit any flaming running or flaming dripping.

2. The surface flammability and smoke emission characteristics must be demonstrated to be permanent by washing, if appropriate, according to FED-STD-191A Textile Test Method 5830.

3. The surface flammability and smoke emission characteristics must be demonstrated to be permanent by dry-cleaning, if appropriate, according to ASTM D-2724. Materials that cannot be washed or dry cleaned must be so labeled and meet the applicable performance criteria after being cleaned as recommended by the manufacturer.

4. For double window glazing, only the interior glazing must meet the materials requirements specified herein; the exterior need not meet those requirements.

5. ASTM E-662 maximum test limits for smoke emission (specified optical density) must be measured in either the flaming or non-flaming mode, depending on which mode generates the most smoke.

6. Structural flooring assemblies must meet the performance criteria during a nominal test period determined by the railroad property. The nominal test period must be twice the maximum expected period of time, under normal circumstances, for a vehicle to come to a complete, safe stop from maximum speed, plus the time necessary to evacuate all passengers from a vehicle to a safe area. The nominal test period must not be less than 15 minutes. Only one specimen need be tested.

A proportional reduction may be made in the dimensions of the specimen provided that it represents a true test of its ability to perform as a barrier against under-car fires. Penetrations (ducts, etc.) must be designed against acting as passageways for fire and smoke.

7. Floor covering must be tested in accordance with ASTM E-648 with its padding, if the padding is used in actual installation.

8. Arm rests, if foamed plastic, are tested as cushions and, if hard material, are tested as a seat back shroud.

9. Testing is performed without upholstery.

10. Carpeting on walls and ceilings is to be considered wall and ceiling panel materials, respectively.

(c) *The sources of test procedures specified in the table are as follows:*

(1) Leaching Resistance of Cloth, FED-STD-191A-Textile Test Method 5830. (Available from: General Services Administration Specifications Division, Building 197 Washington Navy Yard, Washington, D.C. 20407.)

(2) Federal Aviation Administration Vertical Burn Test, FAR-25.853.

(3) American Society for Testing Materials (ASTM):

(i) Specification for Gaskets, ASTM C-542.
 (ii) Surface Flammability of Flexible Cellular Materials Using a Radiant Heat Energy Source, ASTM D-3675.

(iii) Fire Tests of Building Construction and Materials, ASTM E-119.

(iv) Surface Flammability of Materials Using a Radiant Heat Energy Source, STM E-162.

(v) Bonded and Laminated Apparel Fabrics, ASTM D-2724.

(vi) Critical Radiant Flux of Floor Covering Systems Using a Radiant Heat Energy Source, ASTM E-648.

(vii) Specific Optical Density of Smoke Generated by Solid Materials, STM E-662.

(Available from: American Society for Testing Materials, 1916 Race Street, Philadelphia, Pennsylvania 19103.)

Appendix C to Part 238—Suspension System Safety Performance Standards

This appendix contains the minimum suspension system safety performance standards for Tier II passenger equipment as required by § 238.427. These requirements shall be the basis for evaluating suspension system safety performance until an industry standard acceptable to FRA is developed and approved under the procedures provided in § 238.21.

Passenger equipment suspension systems shall be designed to limit the lateral and vertical forces and lateral to vertical (L/V) ratios, for the time duration required to travel six feet at any operating speed or over any class of track, under all operating conditions as determined by the railroad, as follows:

1. The maximum single wheel lateral to vertical force (L/V) ratio shall not exceed Nadal's limit as follows:

$$\text{Wheel L / V} \leq \frac{\tan(\delta) - \mu}{1 + \mu \tan(\delta)} \quad (\text{for positive angle of attack})$$

where: δ=flange angle (deg).
 μ=coefficient of friction of 0.5.

2. The net axle lateral force shall not exceed 0.5 times the static vertical axle load.

3. The vertical wheel/rail force shall be greater than 10 percent of the static vertical wheel load.

4. The sum of the vertical wheel loads on one side of any truck shall be greater than 20

percent of the static vertical axle load. This shall include the effect of a crosswind allowance as specified by the railroad for the intended service.

5. The maximum truck side L/V ratio shall not exceed 0.5.

6. When stopped on track with a uniform 6-inch superelevation, vertical wheel loads, at all wheels, shall be greater than 60 percent

of the nominal vertical wheel load on level track.

Issued in Washington, D.C., on September 12, 1997.

Jolene M. Molitoris,
 Federal Railroad Administrator.

[FR Doc. 97-24713 Filed 9-22-97; 8:45 am]

BILLING CODE 4910-06-P



United States
CONSUMER PRODUCT SAFETY COMMISSION

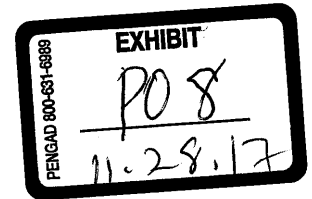

CPSC Guidelines For Television Receiver Safety

Release date: June 1, 1974

Release number: 74-045

Release Details

Numerous reports from manufacturers of potential fire and shock hazards associated with television receivers and consumer complaints of TV- related fire and shock incidents were instrumental in the March 1974 decision of the U.S. Consumer Product Safety Commission to proceed with the development of mandatory safety standards for television receivers.

On April 23 and 24, 1974, the Commission held two days of public hearings to gather additional information from the television industry and to hear from individuals who had personal experience with television fires or with potential TV hazards.

Proceedings for the development of mandatory standards are complicated and often time consuming.

In the interim, the Commission offers the following safety guidelines to assist consumers to reduce the risk of fire and shock hazards associated with home television sets. This advice applies to all television sets; however, consumers who own portable color TV's with plastic cabinets should use special caution because numerous incidents have involved this type of television receiver.

1. Follow all operating instructions and safety precautions that may have been furnished with your TV.
2. If the TV cabinet controls or set are damaged, if the picture fails, or if the performance of the TV deteriorates in any way, unplug the TV and have it checked by a reputable professional service technician.
3. When replacement parts are required, have the service technician verify that the replacements have the same safety characteristics as the original parts.
4. Upon completion of any service or repairs to the TV, ask the service technician to perform the safety checks described in the manufacturer's service literature.

5. It is normal for some TV sets to make occasional snapping or popping sounds, particularly when being turned on or off. However, if the snapping or popping becomes abnormally loud or is continuous or frequent while the TV is operating, unplug the TV and consult your dealer or service technician.

6. Caution children about dropping or pushing objects into the TV cabinet openings. Some internal parts carry hazardous voltages and contact can result in electrical shock.

7. Never operate the TV if liquid has been spilled into it. Unplug the TV and have it inspected by a service technician before further use. Spilled liquid inside can cause electrical shorts which can result in fire or shock hazards.

8. Never clean the face of the picture tube while the TV is on. Excess liquid may drain inside causing a fire or hazard to develop.

9. Never expose the set to rain or water. If the TV becomes damp or wet, pull the plug and have it inspected by a service technician before further use. Rain or excessive moisture -- even as a result of extended exposure on a back porch -- may cause electrical shorts which can result in fire or shock hazards.

10. TV sets are provided with ventilation openings in the cabinet to allow heat generated during the operation to be released. If these openings are blocked, heat build-up within the TV can cause failures which may result in a fire hazard.

Therefore:

-Never cover the openings with cloth or other material.

-Never block the bottom ventilation slots of a portable TV by placing it on a bed, sofa, rug, etc.

-Never place the set near or over a radiator or heat register.

-Never place a set in a "built-in" enclosure unless proper ventilation is provided.

11. Always turn the TV off if it is necessary to leave the room for more than a short period of time. Never leave a TV on when leaving the house.

12. When leaving the home for extended periods of time, such as weekend trips and longer, unplug the TV from the wall outlet and disconnect the external antenna lead-in wires at the TV set. A fire hazard could develop due to lightning storms and electrical powerline surges affecting TV components or the occurrence of TV component failures due to other reasons.

It is not recommended that the TV be routinely unplugged from the wall outlet after each viewing

session. Such a practice can cause the stranded wires within the cord to break and pose a fire hazard. Also, someone could be seriously shocked if the plug is carelessly removed or inserted into the wall outlet.

13. Some TV's have an "instant-on" feature which means that the sound and picture are almost immediately available when the set is turned on. To provide this feature, the TV must have electric current passing through it at **all** times.

In some cases, this feature has been suspected of causing TV fires. If this feature is not desired, it is suggested:

-Review the manual supplied with the TV or check with a dealer to determine if the TV has an "instant-on" defeat switch (sometimes referred to as a "vacation switch"). If so, the "defeat switch" can be switched to the off position.

-If available, plug the TV into a wall outlet controlled (turned on and off) by a standard electrical wall switch generally used to turn lamps and lights on and off. However, caution should be taken to always turn the wall switch on before turning the TV on and to always turn the TV off before turning the wall switch off.

14. If your TV power cord has been subjected to numerous flexings such as from plugging into and unplugging from the wall outlet or from wrapping or folding the cord of a portable TV when carrying it from place to place, or it has become worn for any other reason, have the cord checked by a service technician for possible replacement.

The U.S. Consumer Product Safety Commission is charged with protecting the public from unreasonable risks of injury or death associated with the use of thousands of types of consumer products under the agency's jurisdiction. Deaths, injuries, and property damage from consumer product incidents cost the nation more than \$1 trillion annually. CPSC is committed to protecting consumers and families from products that pose a fire, electrical, chemical or mechanical hazard. CPSC's work to help ensure the safety of consumer products - such as toys, cribs, power tools, cigarette lighters and household chemicals — contributed to a decline in the rate of deaths and injuries associated with consumer products over the past 40 years.

Federal law bars any person from selling products subject to a publicly-announced voluntary recall by a manufacturer or a mandatory recall ordered by the Commission.

To report a dangerous product or a product-related injury go online to www.SaferProducts.gov or call CPSC's Hotline at 800-638-2772 or teletypewriter at 301-595-7054 for the hearing impaired. Consumers can obtain news release and recall information at www.cpsc.gov, on Twitter @USCPSC or by subscribing to CPSC's free e-mail newsletters.

Media Contact

Please use the below phone number for all media requests.

Phone: (301) 504-7908

Spanish: (301) 504-7800

View CPSC contacts for specific areas of expertise

1
2
3
4
5
6
7
8
9
10
11
12
13
14
15
16
17
18
19
20
21
22
23
24
25

LOWELL MALO

THE VIDEOGRAPHER: Okay.

We are now off the record.

The time on the video monitor
is 3:35 p.m.

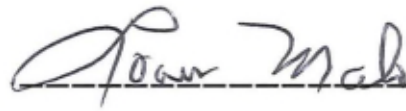

LOWELL MALO

Subscribed and sworn to before me
this 04th day of January, 2018.

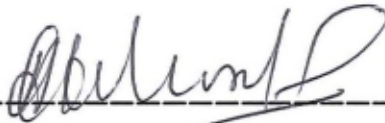

Notary Public

