

Feb. 27, 1968

J. W. SCHUETZ

3,370,451

APPARATUS AND METHOD FOR POINTING TUBES

Filed June 28, 1965

4 Sheets-Sheet 1

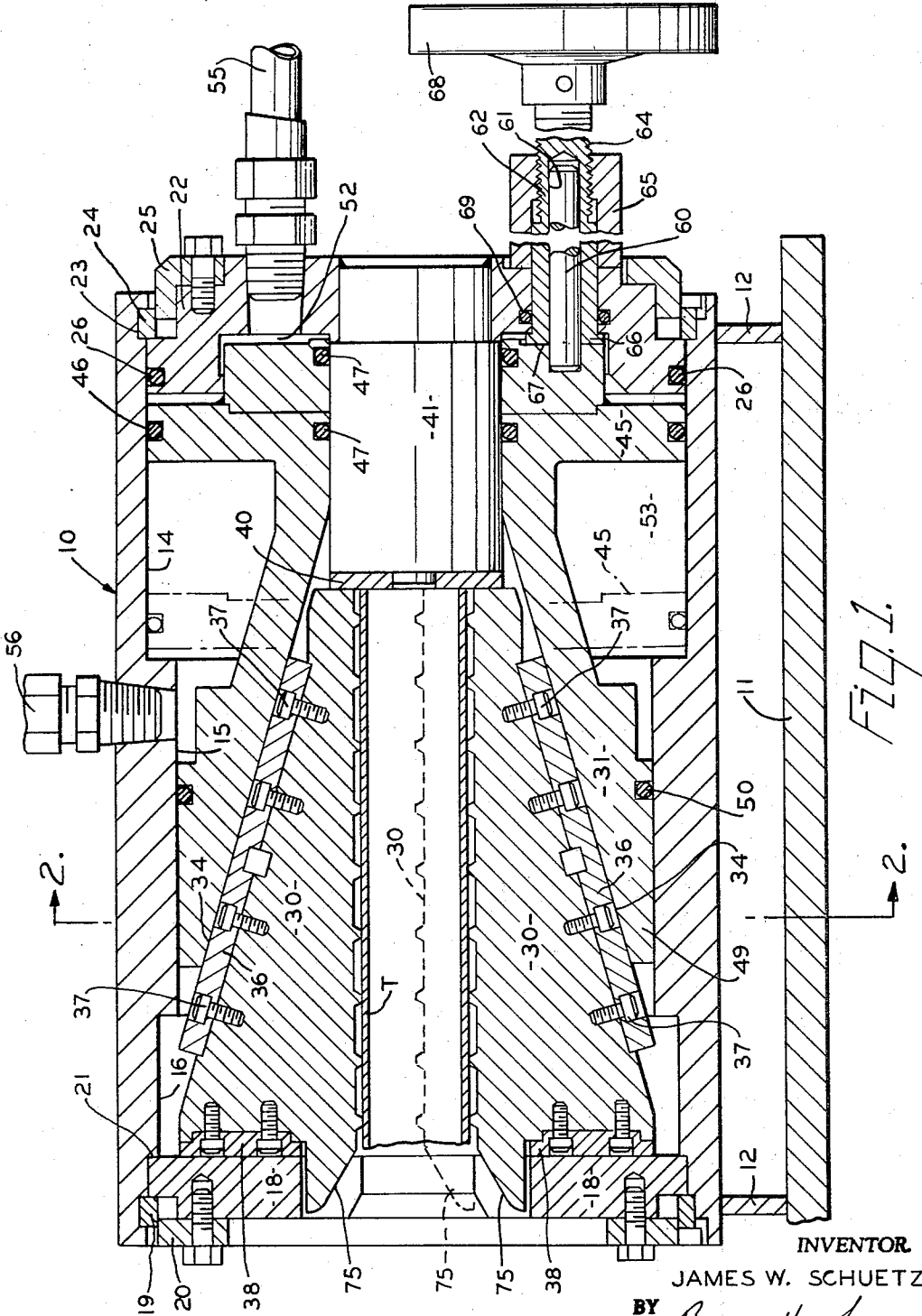

FIG. 1.

INVENTOR
JAMES W. SCHUETZ
BY *Bosworth, Sessions,
Herstrom & Knowles*
ATTORNEYS.

EDWARDS LIFESCIENCES EX 1020

Feb. 27, 1968

J. W. SCHUETZ

3,370,451

APPARATUS AND METHOD FOR POINTING TUBES

Filed June 28, 1965

4 Sheets-Sheet 2

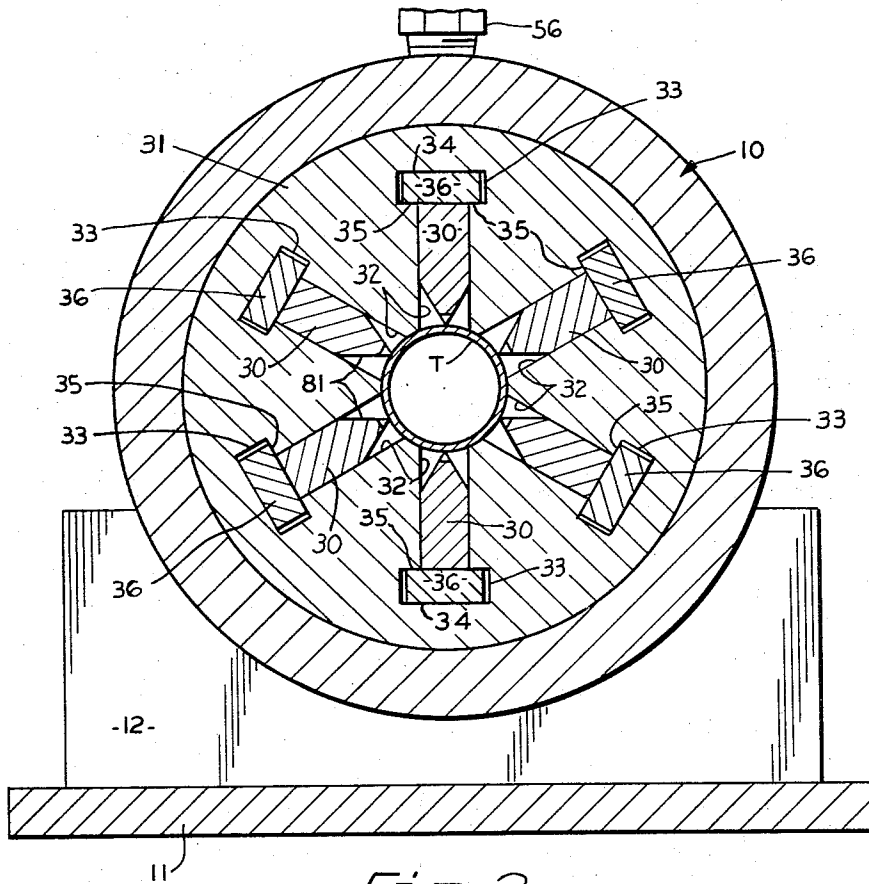

Fig. 2.

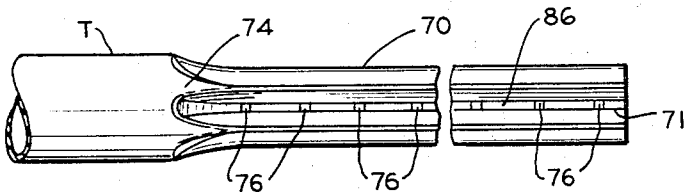

Fig. 3.

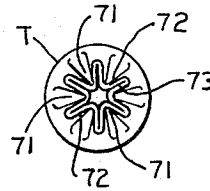

Fig. 4.

INVENTOR
JAMES W. SCHUETZ

BY *Boeworth, Sessions,
Herriott & Knowlton*
ATTORNEYS.

Feb. 27, 1968

J. W. SCHUETZ

3,370,451

APPARATUS AND METHOD FOR POINTING TUBES

Filed June 28, 1965

4 Sheets-Sheet 4

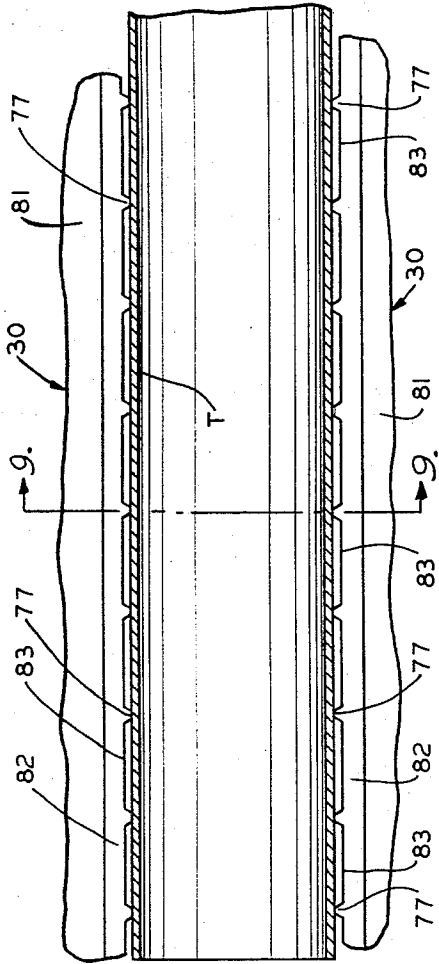

FIG. 8.

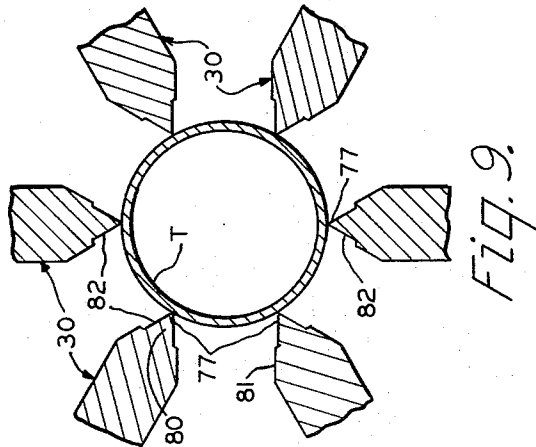

FIG. 9.

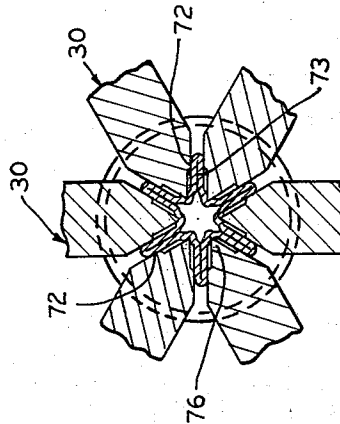

FIG. 10.

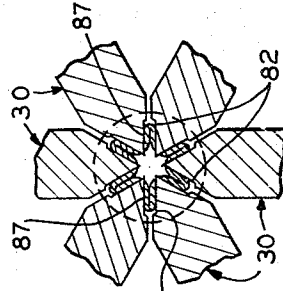

FIG. 11.

INVENTOR
 JAMES W. SCHUETZ
 BY *Bosworth, Sessins,
 Herrstrom & Knowles*
 ATTORNEYS.

1

3,370,451 APPARATUS AND METHOD FOR POINTING TUBES

James W. Schuetz, Pittsburgh, Pa., assignor to Blaw-Knox
Company, Pittsburgh, Pa., a corporation of Delaware
Filed June 28, 1965, Ser. No. 467,235
8 Claims. (Cl. 72-402)

ABSTRACT OF THE DISCLOSURE

Apparatus for pointing metal tubes preparatory to drawing them through a die embodying jaw members angularly spaced apart about a central axis and adapted to fold the walls of a tube inwardly to produce a tube having an end of reduced diameter made up of longitudinally extending ribs separated by intervening flutes. The jaws are V-shaped and have sharp, longitudinally spaced projections that first come into engagement with the wall of the tube and hold the tube properly centered during the pointing operation which takes place in one continuous inward stroke of the jaws.

This invention relates to an apparatus and method for pointing tubes so that they may be inserted into dies for drawing the tubes to reduce their diameter.

It is necessary to provide what is known as a point on the end of a tube before it can be drawn through a die to reduce its diameter; the point must have an overall transverse dimension such that it readily can be inserted through the die and must be long enough so that the projecting end of the point can be grasped by gripper tongs or jaws or the like on the other side of the die. If the drawing operation is to be carried out satisfactorily, the point and the juncture between the point and the remainder of the tube must be nearly as strong as the tube itself so that the metal will not be pulled apart during the drawing operation, and the point should be accurately centered with respect to the tube to prevent distortion of the tube during drawing. Also, the pointing operation should be accomplished quickly and without requiring skill on the part of the operator and the apparatus for carrying out the pointing operation should be sturdy, simple and capable of being manufactured at reasonable cost.

A general object of the present invention is to provide a machine and method for pointing tubes that meets the foregoing requirements. Other objects and advantages of the invention will become apparent from the following description of a preferred form thereof, reference being made to the accompanying drawings in which:

FIGURE 1 is a vertical axial section illustrating a preferred form of apparatus embodying the present invention.

FIGURE 2 is a transverse section taken along line 2-2 of FIGURE 1.

FIGURES 3 and 4 are side elevation and end views, respectively, of a typical tube that has been pointed in the illustrated apparatus.

FIGURES 5 and 6 are side and end elevations, respectively, of one of the gripper jaws used to deform the tube.

FIGURE 7 illustrates the inner or working face of the gripper jaw illustrated in FIGURES 5 and 6.

FIGURE 8 is a fragmentary elevation showing the initial engagement between the gripper jaws and a tube to be pointed.

FIGURE 9 is a section taken as indicated by line 9-9 of FIGURE 8.

FIGURE 10 is a similar section, but showing the jaws in their innermost position.

FIGURE 11 is similar to FIGURE 10, but shows a tube of the size shown in FIG-

2

Briefly, a preferred form of apparatus comprises a fluid operated chuck or similar mechanism that is adapted to urge a series of V-shaped gripper jaws or dies radially inwardly into engagement with the length of tube to be pointed. The jaws each have a series of longitudinally spaced points that first engage the tube and thus hold the tube against slippage with respect to the dies. As the jaws move inwardly, they fold the tube into a fluted form having a maximum dimension sufficiently smaller than the original outer diameter of the tube to permit the end of the tube readily to be inserted into the drawing die. The folding operation is completed in one continuous movement of the jaws and as soon as the inward movement of the jaws is completed, they are automatically retracted so that the tube can be removed from the apparatus ready for drawing through a die.

As shown in FIGURES 1 and 2 of the drawings, a preferred form of apparatus comprises a cylinder 10 supported on an appropriate base made up of a horizontal plate 11 and vertical plates 12 disposed at either end of the cylinder 10 and having arcuate saddle portions to receive the cylinder. The vertical members 12 preferably are welded to the base member 11 and the cylinder 10 may be welded to the vertical members 12. The internal bore of the cylinder 10 has a rear portion 14 of greatest diameter, an intermediate portion 15 of reduced diameter and a forward end portion 16 of enlarged diameter as compared to the intermediate portion 15. At the front end of the cylinder there is a front cylinder head 18 that is held in place by a key 19 and an annular ring 20 and is prevented from inward movement by a shoulder 21 in the cylinder bore. There is also a rear cylinder head 22 that is held in place against a shoulder 23 in the cylinder bore by a key 24 and a ring 25. The rear cylinder head 25 is sealed to the cylinder as by a conventional O-ring 26.

In order to form the required points on tubes, a plurality of angularly spaced gripper jaws 30 are disposed within the cylinder. Six jaws are shown in the drawings, but fewer or more jaws can be employed if desired. A tube T is shown in FIGURES 1 and 2 to illustrate the initial engagement between the jaws and the tubes. In order to move the jaws 30 inwardly to deform the tube to provide the desired flutes and reduce the diameter thereof, a hydraulically operated chuck 31 is disposed within the cylinder 10. Chuck 31 is provided with radial slots 32 in which the jaws 30 are slidably mounted and in order to move the jaws inwardly and outwardly upon axial movement of the chuck, the slots 32 are T-shaped as shown, with enlarged head openings 33 that are defined by sloping outer camming surfaces 34 and inner camming surfaces 35 that are parallel to the surfaces 34. The jaws 30 are provided with T heads 36, preferably composed of a material such as bronze in order to reduce friction the strips being secured to the jaws by cap screws 37. The forward ends of the jaws are provided with wear plate 38 that bear against the inner surface of the forward cylinder head 18 while the rear ends of the jaws bear against a washer 40 that is supported by a plug 41 that projects inwardly from the rear cylinder head 22. The jaws are prevented from longitudinal movement by the front cylinder head 18 and the washer 40 and thus reciprocal movement of the chuck 31 within the cylinder 10 will cause the dies to move radially inwardly and outwardly. The jaws and the chuck are shown in full line in FIGURE 1 in their fully retracted position; the broken lines in the lower part of FIGURE 1 indicate the innermost position of the jaws and the corresponding forward position of the chuck.

In order to reciprocate the chuck 31 within the cylinder 10, the chuck is provided with a rear piston portion 42 that operates within the bore 14 and also slides along the inner surface of the cylinder 10, the rear portion 45 being sealed to the

Explore Litigation Insights

Docket Alarm provides insights to develop a more informed litigation strategy and the peace of mind of knowing you're on top of things.

Real-Time Litigation Alerts



Keep your litigation team up-to-date with **real-time alerts** and advanced team management tools built for the enterprise, all while greatly reducing PACER spend.

Our comprehensive service means we can handle Federal, State, and Administrative courts across the country.

Advanced Docket Research



With over 230 million records, Docket Alarm's cloud-native docket research platform finds what other services can't. Coverage includes Federal, State, plus PTAB, TTAB, ITC and NLRB decisions, all in one place.

Identify arguments that have been successful in the past with full text, pinpoint searching. Link to case law cited within any court document via Fastcase.

Analytics At Your Fingertips



Learn what happened the last time a particular judge, opposing counsel or company faced cases similar to yours.

Advanced out-of-the-box PTAB and TTAB analytics are always at your fingertips.

API

Docket Alarm offers a powerful API (application programming interface) to developers that want to integrate case filings into their apps.

LAW FIRMS

Build custom dashboards for your attorneys and clients with live data direct from the court.

Automate many repetitive legal tasks like conflict checks, document management, and marketing.

FINANCIAL INSTITUTIONS

Litigation and bankruptcy checks for companies and debtors.

E-DISCOVERY AND LEGAL VENDORS

Sync your system to PACER to automate legal marketing.