



US008992608B2

(12) **United States Patent**  
**Haug et al.**

(10) **Patent No.:** **US 8,992,608 B2**  
(45) **Date of Patent:** **Mar. 31, 2015**

(54) **EVERTING HEART VALVE**  
(75) Inventors: **Ulrich R. Haug**, Campbell, CA (US);  
**Hans F. Valencia**, Berkeley, CA (US);  
**Robert A. Geshliger**, San Francisco, CA  
(US); **Tom Saul**, El Granada, CA (US);  
**Amr Salahieh**, Saratoga, CA (US);  
**Dwight P. Morejohn**, Davis, CA (US);  
**Kenneth J. Michlitsch**, Livermore, CA  
(US)

2,682,057 A 6/1954 Lord

(Continued)

**FOREIGN PATENT DOCUMENTS**

CN 1338951 A 3/2002  
DE 19532846 3/1997

(Continued)

**OTHER PUBLICATIONS**

Paul et al.; U.S. Appl. No. 12/578,463 entitled "Medical Devices and Delivery Systems for Delivering Medical Devices," filed Oct. 13, 2009.

(Continued)

(73) Assignee: **Sadra Medical, Inc.**, Los Gatos, CA (US)

(\* ) Notice: Subject to any disclaimer, the term of this patent is extended or adjusted under 35 U.S.C. 154(b) by 88 days.

(21) Appl. No.: **12/492,512**

(22) Filed: **Jun. 26, 2009**

(65) **Prior Publication Data**

US 2009/0264997 A1 Oct. 22, 2009

**Related U.S. Application Data**

(60) Division of application No. 12/269,213, filed on Nov. 12, 2008, now Pat. No. 8,668,733, which is a continuation of application No. 10/870,340, filed on Jun. 16, 2004, now Pat. No. 7,780,725.

(51) **Int. Cl.**  
**A61F 2/24** (2006.01)

(52) **U.S. Cl.**  
CPC ..... **A61F 2/2418** (2013.01); **A61F 2/2433** (2013.01); **A61F 2/2436** (2013.01); **A61F 2/2439** (2013.01);

(Continued)

(58) **Field of Classification Search**

CPC ..... A61F 2/2412; A61F 2/2427; A61F 2220/0016; A61F 2/24; A61F 2/2454; A61F 2/07  
USPC ..... 623/1.11-1.54  
See application file for complete search history.

(56) **References Cited**

**U.S. PATENT DOCUMENTS**

15,192 A 6/1856 Peale

*Primary Examiner* — David Isabella  
*Assistant Examiner* — Ann Schillinger

(74) *Attorney, Agent, or Firm* — Vidas, Arrett & Steinkraus, P.A.

(57) **ABSTRACT**

The present invention provides methods and apparatus for endovascularly replacing a patient's heart valve. The apparatus includes a replacement valve and an expandable anchor configured for endovascular delivery to a vicinity of the patient's heart valve. In some embodiments, the replacement valve is adapted to wrap about the anchor, for example, by everting during endovascular deployment. In some embodiments, the replacement valve is not connected to expandable portions of the anchor. In some embodiments, the anchor is configured for active foreshortening during endovascular deployment. In some embodiments, the anchor includes expandable lip and skirt regions for engaging the patient's heart valve during deployment. In some embodiments, the anchor comprises a braid fabricated from a single strand of wire. In some embodiments, the apparatus includes a lock configured to maintain anchor expansion. The invention also includes methods for endovascularly replacing a patient's heart valve. In some embodiments, the method includes the steps of endovascularly delivering a replacement valve and an expandable anchor to a vicinity of the heart valve, wrapping at least a portion of the replacement valve about the anchor, and expanding the anchor to a deployed configuration.

**9 Claims, 63 Drawing Sheets**

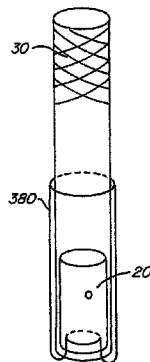

- (52) **U.S. Cl.**  
 CPC ... *A61F 2220/0016* (2013.01); *A61F 2220/005*  
 (2013.01); *A61F 2220/0058* (2013.01); *A61F*  
*2220/0075* (2013.01); *A61F 2230/005*  
 (2013.01); *A61F 2230/0054* (2013.01); *A61F*  
*2230/0065* (2013.01); *A61F 2230/0078*  
 (2013.01)  
 USPC ..... **623/2.38**

(56)

**References Cited**

## U.S. PATENT DOCUMENTS

2,701,559 A	2/1955	Cooper	4,692,164 A	9/1987	Dzemeshevich et al.
2,832,078 A	4/1958	Williams	4,705,516 A	11/1987	Barone et al.
3,099,016 A	7/1963	Edwards	4,710,192 A	12/1987	Liotta et al.
3,113,586 A	12/1963	Edmark, Jr.	4,733,665 A	3/1988	Palmaz
3,130,418 A	4/1964	Head et al.	4,755,181 A	7/1988	Igoe
3,143,742 A	8/1964	Cromie	4,759,758 A	7/1988	Gabbay
3,334,629 A	8/1967	Cohn	4,777,951 A	10/1988	Cribier et al.
3,367,364 A	2/1968	Cruz, Jr. et al.	4,787,899 A	11/1988	Lazarus
3,409,013 A	11/1968	Berry	4,787,901 A	11/1988	Baykut
3,445,916 A	5/1969	Schulte	4,796,629 A	1/1989	Grayzel
3,540,431 A	11/1970	Mobin-Uddin	4,819,751 A	4/1989	Shimada et al.
3,548,417 A	12/1970	Kischer	4,829,990 A	5/1989	Thuroff et al.
3,570,014 A	3/1971	Hancock	4,834,755 A	5/1989	Silvestrini et al.
3,587,115 A	6/1971	Shiley	4,851,001 A	7/1989	Taheri
3,592,184 A	7/1971	Watkins et al.	4,856,516 A	8/1989	Hillstead
3,628,535 A	12/1971	Ostrowsky et al.	4,865,600 A	9/1989	Carpentier et al.
3,642,004 A	2/1972	Osthagen et al.	4,872,874 A	10/1989	Taheri
3,657,744 A	4/1972	Ersek	4,873,978 A	10/1989	Ginsburg
3,671,979 A	6/1972	Moulopoulos	4,878,495 A	11/1989	Grayzel
3,714,671 A	2/1973	Edwards et al.	4,878,906 A	11/1989	Lindemann et al.
3,755,823 A	9/1973	Hancock	4,883,458 A	11/1989	Shiber
3,795,246 A	3/1974	Sturgeon	4,885,005 A	12/1989	Nashef et al.
3,839,741 A	10/1974	Haller	4,909,252 A	3/1990	Goldberger
3,868,956 A	3/1975	Alfidi et al.	4,917,102 A	4/1990	Miller et al.
3,874,388 A	4/1975	King et al.	4,922,905 A	5/1990	Strecker
3,997,923 A	12/1976	Possis	4,927,426 A	5/1990	Dretler
4,035,849 A	7/1977	Angell et al.	4,954,126 A	9/1990	Wallsten
4,056,854 A	11/1977	Boretos et al.	4,966,604 A	10/1990	Reiss
4,106,129 A	8/1978	Carpentier et al.	4,969,890 A	11/1990	Sugita et al.
4,222,126 A	9/1980	Boretos et al.	4,979,939 A	12/1990	Shiber
4,233,690 A	11/1980	Akins	4,986,830 A	1/1991	Owens et al.
4,265,694 A	5/1981	Boretos et al.	4,994,077 A	2/1991	Dobben
4,291,420 A	9/1981	Reul	5,002,556 A	3/1991	Ishida et al.
4,297,749 A	11/1981	Davis et al.	5,002,559 A	3/1991	Tower
4,323,358 A	4/1982	Lentz et al.	5,007,896 A	4/1991	Shiber
4,326,306 A	4/1982	Poler	5,026,366 A	6/1991	Leckrone
4,339,831 A	7/1982	Johnson	5,032,128 A	7/1991	Alonso
4,343,048 A	8/1982	Ross et al.	5,037,434 A	8/1991	Lane
4,345,340 A	8/1982	Rosen	5,047,041 A	9/1991	Samuels
4,373,216 A	2/1983	Klawitter	5,064,435 A	11/1991	Porter
4,406,022 A	9/1983	Roy	5,080,668 A	1/1992	Bolz et al.
4,423,809 A	1/1984	Mazzocco	5,085,635 A	2/1992	Cragg
4,425,908 A	1/1984	Simon	5,089,015 A	2/1992	Ross
4,470,157 A	9/1984	Love	5,132,473 A	7/1992	Furutaka et al.
4,484,579 A	11/1984	Meno et al.	5,141,494 A	8/1992	Danforth et al.
4,501,030 A	2/1985	Lane	5,152,771 A	10/1992	Sabbaghian et al.
4,531,943 A	7/1985	Van Tassel et al.	5,159,937 A	11/1992	Tremulis
4,535,483 A	8/1985	Klawitter et al.	5,161,547 A	11/1992	Tower
4,574,803 A	3/1986	Storz	5,163,953 A	11/1992	Vince
4,580,568 A	4/1986	Gianturco	5,167,628 A	12/1992	Boyles
4,592,340 A	6/1986	Boyles	5,209,741 A	5/1993	Spaeth
4,602,911 A	7/1986	Ahmadi et al.	5,215,541 A	6/1993	Nashef et al.
4,605,407 A	8/1986	Black et al.	5,217,483 A	6/1993	Tower
4,610,688 A	9/1986	Silvestrini et al.	5,258,023 A	11/1993	Reger
4,612,011 A	9/1986	Kautzky	5,258,042 A	11/1993	Mehta
4,617,932 A	10/1986	Kornberg	5,282,847 A	2/1994	Trescony et al.
4,643,732 A	2/1987	Pietsch et al.	5,295,958 A	3/1994	Shturman
4,647,283 A	3/1987	Carpentier et al.	5,332,402 A	7/1994	Teitelbaum
4,648,881 A	3/1987	Carpentier et al.	5,336,258 A	8/1994	Quintero et al.
4,655,218 A	4/1987	Kulik et al.	5,350,398 A	9/1994	Pavcnik et al.
4,655,771 A	4/1987	Wallsten	5,360,444 A	11/1994	Kusuhara
4,662,885 A	5/1987	DiPisa, Jr.	5,370,685 A	12/1994	Stevens
4,665,906 A	5/1987	Jervis	5,389,106 A	2/1995	Tower
4,680,031 A	7/1987	Alonso	5,397,351 A	3/1995	Pavcnik et al.
			5,409,019 A	4/1995	Wilk
			5,411,552 A	5/1995	Andersen et al.
			5,425,762 A	6/1995	Muller
			5,431,676 A	7/1995	Dubrul et al.
			5,443,446 A	8/1995	Shturman
			5,443,449 A	8/1995	Buelna
			5,443,477 A	8/1995	Marin et al.
			5,443,495 A	8/1995	Buscemi et al.
			5,443,499 A	8/1995	Schmitt
			5,476,506 A	12/1995	Lunn
			5,476,510 A	12/1995	Eberhardt et al.
			5,480,423 A	1/1996	Ravenscroft et al.
			5,480,424 A	1/1996	Cox
			5,500,014 A	3/1996	Quijano et al.
			5,507,767 A	4/1996	Maeda et al.

(56)

References Cited

U.S. PATENT DOCUMENTS

5,534,007	A	7/1996	St. Germain et al.	6,022,370	A	2/2000	Tower
5,545,133	A	8/1996	Burns et al.	6,027,520	A	2/2000	Tsugita et al.
5,545,209	A	8/1996	Roberts et al.	6,027,525	A	2/2000	Suh et al.
5,545,211	A	8/1996	An et al.	6,042,598	A	3/2000	Tsugita et al.
5,545,214	A	8/1996	Stevens	6,042,607	A	3/2000	Williamson, IV et al.
5,549,665	A	8/1996	Vesely et al.	6,051,014	A	4/2000	Jang
5,554,185	A	9/1996	Block et al.	6,059,827	A	5/2000	Fenton, Jr.
5,571,175	A	11/1996	Vanney et al.	6,074,418	A	6/2000	Buchanan et al.
5,571,215	A	11/1996	Sterman et al.	6,093,203	A	7/2000	Uflacker
5,573,520	A	11/1996	Schwartz et al.	6,096,074	A	8/2000	Pedros
5,575,818	A	11/1996	Pinchuk	6,123,723	A	9/2000	Konya et al.
5,591,185	A	1/1997	Kilmer et al.	6,132,473	A	10/2000	Williams et al.
5,591,195	A	1/1997	Taheri et al.	6,142,987	A	11/2000	Tsugita
5,607,464	A	3/1997	Trescony et al.	6,146,366	A	11/2000	Schachar
5,609,626	A	3/1997	Quijano et al.	6,162,245	A	12/2000	Jayaraman
5,645,559	A	7/1997	Hachtman et al.	6,165,200	A	12/2000	Tsugita et al.
5,662,671	A	9/1997	Barbut et al.	6,165,209	A	12/2000	Patterson et al.
5,667,523	A	9/1997	Bynon et al.	6,168,579	B1	1/2001	Tsugita
5,674,277	A	10/1997	Freitag	6,168,614	B1	1/2001	Andersen et al.
5,693,083	A	12/1997	Baker et al.	6,171,327	B1	1/2001	Daniel et al.
5,693,310	A	12/1997	Gries et al.	6,171,335	B1	1/2001	Wheatley et al.
5,695,498	A	12/1997	Tower	6,179,859	B1	1/2001	Bates
5,709,713	A	1/1998	Evans et al.	6,187,016	B1	2/2001	Hedges et al.
5,713,951	A	2/1998	Garrison et al.	6,197,053	B1	3/2001	Cosgrove et al.
5,713,953	A	2/1998	Vallana et al.	6,200,336	B1	3/2001	Pavcnik et al.
5,716,370	A	2/1998	Williamson, IV et al.	6,214,036	B1	4/2001	Letendre et al.
5,716,417	A	2/1998	Girard et al.	6,221,006	B1	4/2001	Dubrul et al.
5,720,391	A	2/1998	Dohm et al.	6,221,091	B1	4/2001	Khosravi
5,725,549	A	3/1998	Lam	6,221,096	B1	4/2001	Aiba et al.
5,728,068	A	3/1998	Leone et al.	6,221,100	B1	4/2001	Strecker
5,733,325	A	3/1998	Robinson et al.	6,231,544	B1	5/2001	Tsugita et al.
5,735,842	A	4/1998	Krueger et al.	6,231,551	B1	5/2001	Barbut
5,749,890	A	5/1998	Shaknovich	6,241,757	B1	6/2001	An et al.
5,755,783	A	5/1998	Stobie et al.	6,245,102	B1	6/2001	Jayaraman
5,756,476	A	5/1998	Epstein et al.	6,251,135	B1	6/2001	Stinson et al.
5,769,812	A	6/1998	Stevens et al.	6,258,114	B1	7/2001	Konya et al.
5,800,456	A	9/1998	Maeda et al.	6,258,115	B1	7/2001	Dubrul
5,800,531	A	9/1998	Cosgrove et al.	6,258,120	B1	7/2001	McKenzie et al.
5,807,405	A	9/1998	Vanney et al.	6,258,129	B1	7/2001	Dybdal et al.
5,817,126	A	10/1998	Imran	6,267,783	B1	7/2001	Letendre et al.
5,824,041	A	10/1998	Lenker et al.	6,270,513	B1	8/2001	Tsugita et al.
5,824,043	A	10/1998	Cottone, Jr.	6,277,555	B1	8/2001	Duran et al.
5,824,053	A	10/1998	Khosravi et al.	6,299,637	B1	10/2001	Shaolian et al.
5,824,055	A	10/1998	Spiridigliozzi et al.	6,302,906	B1	10/2001	Goicoechea et al.
5,824,056	A	10/1998	Rosenberg	6,309,417	B1	10/2001	Spence et al.
5,824,064	A	10/1998	Taheri	6,319,281	B1	11/2001	Patel
5,840,081	A	11/1998	Andersen et al.	6,327,772	B1	12/2001	Zadno-Azizi et al.
5,843,158	A	12/1998	Lenker et al.	6,336,934	B1	1/2002	Gilson et al.
5,855,597	A	1/1999	Jayaraman	6,336,937	B1	1/2002	Vonesh et al.
5,855,601	A	1/1999	Bessler et al.	6,338,735	B1	1/2002	Stevens
5,855,602	A	1/1999	Angell	6,346,116	B1	2/2002	Brooks et al.
5,860,966	A	1/1999	Tower	6,348,063	B1	2/2002	Yassour et al.
5,861,024	A	1/1999	Rashidi	6,352,554	B2*	3/2002	De Paulis ..... 623/1.26
5,861,028	A	1/1999	Angell	6,352,708	B1	3/2002	Duran et al.
5,868,783	A	2/1999	Tower	6,361,545	B1	3/2002	Macoviak et al.
5,876,419	A	3/1999	Carpenter et al.	6,363,938	B2	4/2002	Saadat et al.
5,876,448	A	3/1999	Thompson et al.	6,364,895	B1	4/2002	Greenhalgh
5,885,228	A	3/1999	Rosenman et al.	6,371,970	B1	4/2002	Khosravi et al.
5,888,201	A	3/1999	Stinson et al.	6,371,983	B1	4/2002	Lane
5,891,191	A	4/1999	Stinson	6,379,383	B1	4/2002	Palmaz et al.
5,895,399	A	4/1999	Barbut et al.	6,398,807	B1	6/2002	Chouinard et al.
5,906,619	A	5/1999	Olson et al.	6,402,736	B1	6/2002	Brown et al.
5,907,893	A	6/1999	Zadno-Azizi et al.	6,409,750	B1	6/2002	Hyodoh et al.
5,910,154	A	6/1999	Tsugita et al.	6,416,510	B1	7/2002	Altman et al.
5,911,734	A	6/1999	Tsugita et al.	6,425,916	B1	7/2002	Garrison et al.
5,925,063	A	7/1999	Khosravi	6,440,164	B1	8/2002	DiMatteo et al.
5,944,738	A	8/1999	Amplatz et al.	6,454,799	B1	9/2002	Schreck
5,954,766	A	9/1999	Zadno-Azizi et al.	6,458,153	B1	10/2002	Bailey et al.
5,957,949	A*	9/1999	Leonhardt et al. .... 623/1.24	6,461,382	B1	10/2002	Cao
5,968,070	A	10/1999	Bley et al.	6,468,303	B1	10/2002	Amplatz et al.
5,984,957	A	11/1999	Laptewicz, Jr. et al.	6,468,660	B2	10/2002	Ogle et al.
5,984,959	A	11/1999	Robertson et al.	6,475,239	B1	11/2002	Campbell et al.
5,993,469	A	11/1999	McKenzie et al.	6,482,228	B1	11/2002	Norred
5,997,557	A	12/1999	Barbut et al.	6,485,501	B1	11/2002	Green
6,010,522	A	1/2000	Barbut et al.	6,485,502	B2	11/2002	Don Michael et al.
				6,488,704	B1	12/2002	Connelly et al.
				6,494,909	B2	12/2002	Greenhalgh
				6,503,272	B2	1/2003	Duerig et al.
				6,508,833	B2	1/2003	Pavcnik et al.

(56)

## References Cited

## U.S. PATENT DOCUMENTS

6,527,800	B1	3/2003	McGuckin, Jr. et al.	6,872,226	B2	3/2005	Cali et al.
6,530,949	B2	3/2003	Konya et al.	6,875,231	B2	4/2005	Anduiza et al.
6,530,952	B2	3/2003	Vesely	6,881,220	B2	4/2005	Edwin et al.
6,537,297	B2	3/2003	Tsugita et al.	6,887,266	B2	5/2005	Williams et al.
6,540,768	B1	4/2003	Diaz et al.	6,890,340	B2	5/2005	Duane
6,562,058	B2	5/2003	Seguin et al.	6,893,459	B1	5/2005	Macoviak
6,569,196	B1	5/2003	Vesely	6,893,460	B2	5/2005	Spenser et al.
6,572,643	B1	6/2003	Gharibadeh	6,905,743	B1	6/2005	Chen et al.
6,585,766	B1	7/2003	Huynh et al.	6,908,481	B2	6/2005	Cribier
6,592,546	B1	7/2003	Barbut et al.	6,911,036	B2	6/2005	Douk et al.
6,592,614	B2	7/2003	Lenker et al.	6,911,043	B2	6/2005	Myers et al.
6,605,112	B1	8/2003	Moll et al.	6,936,058	B2	8/2005	Forde et al.
6,610,077	B1	8/2003	Hancock et al.	6,936,067	B2	8/2005	Buchanan
6,616,682	B2	9/2003	Joergensen et al.	6,939,352	B2	9/2005	Buzzard et al.
6,622,604	B1	9/2003	Chouinard et al.	6,951,571	B1	10/2005	Srivastava
6,623,518	B2	9/2003	Thompson et al.	6,953,332	B1	10/2005	Kurk et al.
6,623,521	B2	9/2003	Steinke et al.	6,964,673	B2	11/2005	Tsugita et al.
6,632,243	B1	10/2003	Zadno-Azizi et al.	6,969,395	B2	11/2005	Eskuri
6,635,068	B1	10/2003	Dubrul et al.	6,972,025	B2	12/2005	WasDyke
6,635,079	B2	10/2003	Unsworth et al.	6,974,464	B2	12/2005	Quijano et al.
6,652,571	B1	11/2003	White et al.	6,974,474	B2	12/2005	Pavcnik et al.
6,652,578	B2	11/2003	Bailey et al.	6,974,476	B2	12/2005	McGuckin, Jr. et al.
6,663,588	B2	12/2003	DuBois et al.	6,979,350	B2	12/2005	Moll et al.
6,663,663	B2	12/2003	Kim et al.	6,984,242	B2	1/2006	Campbell et al.
6,669,724	B2	12/2003	Park et al.	6,989,027	B2	1/2006	Allen et al.
6,673,089	B1	1/2004	Yassour et al.	7,004,176	B2	2/2006	Lau
6,673,109	B2	1/2004	Cox	7,011,681	B2	3/2006	Vesely
6,676,668	B2	1/2004	Mercereau et al.	7,018,406	B2	3/2006	Seguin et al.
6,676,692	B2	1/2004	Rabkin et al.	7,025,791	B2	4/2006	Levine et al.
6,676,698	B2	1/2004	McGuckin, Jr. et al.	7,037,331	B2	5/2006	Mitelberg et al.
6,682,543	B2	1/2004	Barbut et al.	7,041,132	B2	5/2006	Quijano et al.
6,682,558	B2	1/2004	Tu et al.	7,097,658	B2	8/2006	Oktay
6,682,559	B2	1/2004	Myers et al.	7,122,020	B2	10/2006	Mogul
6,685,739	B2	2/2004	DiMatteo et al.	7,125,418	B2	10/2006	Duran et al.
6,689,144	B2	2/2004	Gerberding	7,141,063	B2	11/2006	White et al.
6,689,164	B1	2/2004	Seguin	7,166,097	B2	1/2007	Barbut
6,692,512	B2	2/2004	Jang	7,175,653	B2	2/2007	Gaber
6,695,864	B2	2/2004	Macoviak et al.	7,175,654	B2	2/2007	Bonsignore et al.
6,695,865	B2	2/2004	Boyle et al.	7,175,656	B2	2/2007	Khairkhahan
6,702,851	B1	3/2004	Chinn et al.	7,189,258	B2	3/2007	Johnson et al.
6,712,842	B1	3/2004	Gifford et al.	7,191,018	B2	3/2007	Gielen et al.
6,712,843	B2	3/2004	Elliott	7,201,772	B2	4/2007	Schwammenthal et al.
6,714,842	B1	3/2004	Ito	7,235,093	B2	6/2007	Gregorich
6,719,789	B2	4/2004	Cox	7,258,696	B2	8/2007	Rabkin et al.
6,723,116	B2	4/2004	Taheri	7,267,686	B2	9/2007	DiMatteo et al.
6,730,118	B2	5/2004	Spenser et al.	7,276,078	B2	10/2007	Spenser et al.
6,730,377	B2	5/2004	Wang	7,322,932	B2	1/2008	Xie et al.
6,733,525	B2	5/2004	Yang et al.	7,326,236	B2	2/2008	Andreas et al.
6,736,846	B2	5/2004	Cox	7,329,279	B2	2/2008	Haug et al.
6,752,828	B2	6/2004	Thornton	7,374,560	B2	5/2008	Ressemann et al.
6,755,854	B2	6/2004	Gillick et al.	7,381,219	B2	6/2008	Salahieh et al.
6,758,855	B2	7/2004	Fulton, III et al.	7,381,220	B2	6/2008	Macoviak et al.
6,764,503	B1	7/2004	Ishimaru	7,399,315	B2	7/2008	Iobbi
6,764,509	B2	7/2004	Chinn et al.	7,445,631	B2	11/2008	Salahieh et al.
6,767,345	B2	7/2004	St. Germain et al.	7,470,285	B2	12/2008	Nugent et al.
6,769,434	B2	8/2004	Liddicoat et al.	7,491,232	B2	2/2009	Bolduc et al.
6,773,454	B2	8/2004	Wholey et al.	7,510,574	B2	3/2009	Le et al.
6,776,791	B1	8/2004	Stallings et al.	7,524,330	B2	4/2009	Berrekouw
6,786,925	B1	9/2004	Schoon et al.	7,530,995	B2	5/2009	Quijano et al.
6,790,229	B1	9/2004	Berrekouw	7,544,206	B2	6/2009	Cohn
6,790,230	B2	9/2004	Beyersdorf et al.	7,622,276	B2	11/2009	Cunanan et al.
6,790,237	B2	9/2004	Stinson	7,628,803	B2	12/2009	Pavcnik et al.
6,792,979	B2	9/2004	Konya et al.	7,632,298	B2	12/2009	Hijlkema et al.
6,797,002	B2	9/2004	Spence et al.	7,674,282	B2	3/2010	Wu et al.
6,814,746	B2	11/2004	Thompson et al.	7,712,606	B2	5/2010	Salahieh et al.
6,821,297	B2	11/2004	Snyders	7,722,638	B2	5/2010	Deyette, Jr. et al.
6,830,585	B1	12/2004	Artof et al.	7,722,662	B2	5/2010	Steinke et al.
6,837,901	B2	1/2005	Rabkin et al.	7,722,666	B2	5/2010	Lafontaine
6,840,957	B2	1/2005	DiMatteo et al.	7,736,388	B2	6/2010	Goldfarb et al.
6,843,802	B1	1/2005	Villalobos et al.	7,748,389	B2	7/2010	Salahieh et al.
6,849,085	B2	2/2005	Marton	7,758,625	B2	7/2010	Wu et al.
6,863,668	B2	3/2005	Gillespie et al.	7,780,725	B2	8/2010	Haug et al.
6,866,650	B2	3/2005	Stevens et al.	7,799,065	B2	9/2010	Pappas
6,866,669	B2	3/2005	Buzzard et al.	7,803,185	B2	9/2010	Gabbay
6,872,223	B2	3/2005	Roberts et al.	7,824,442	B2	11/2010	Salahieh et al.
				7,824,443	B2	11/2010	Salahieh et al.
				7,833,262	B2	11/2010	McGuckin, Jr. et al.
				7,846,204	B2	12/2010	Letac et al.
				7,892,292	B2	2/2011	Stack et al.



(56)

References Cited

U.S. PATENT DOCUMENTS

7,918,880	B2	4/2011	Austin	2003/0023303	A1	1/2003	Palmaz et al.
7,938,851	B2	5/2011	Olson et al.	2003/0028247	A1	2/2003	Cali
7,959,666	B2	6/2011	Salahieh et al.	2003/0036791	A1	2/2003	Philipp et al.
7,959,672	B2	6/2011	Salahieh et al.	2003/0040736	A1	2/2003	Stevens et al.
7,988,724	B2	8/2011	Salahieh et al.	2003/0040771	A1	2/2003	Hyodoh et al.
8,048,153	B2	11/2011	Salahieh et al.	2003/0040772	A1	2/2003	Hyodoh et al.
8,052,749	B2	11/2011	Salahieh et al.	2003/0040791	A1	2/2003	Oktay
8,182,528	B2	5/2012	Salahieh et al.	2003/0040792	A1	2/2003	Gabbay
8,192,351	B2	6/2012	Fishler et al.	2003/0050694	A1	3/2003	Yang et al.
8,226,710	B2	7/2012	Nguyen et al.	2003/0055495	A1	3/2003	Pease et al.
8,231,670	B2	7/2012	Salahieh et al.	2003/0057156	A1	3/2003	Peterson et al.
8,236,049	B2	8/2012	Rowe et al.	2003/0060844	A1	3/2003	Borillo et al.
8,246,678	B2	8/2012	Salahieh et al.	2003/0069492	A1	4/2003	Abrams et al.
8,252,051	B2	8/2012	Chau et al.	2003/0069646	A1	4/2003	Stinson
8,252,052	B2	8/2012	Salahieh et al.	2003/0070944	A1	4/2003	Nigam
8,308,798	B2	11/2012	Pintor et al.	2003/0100918	A1	5/2003	Duane
8,323,335	B2	12/2012	Rowe et al.	2003/0100919	A1	5/2003	Hopkins et al.
8,328,868	B2	12/2012	Paul et al.	2003/0109924	A1	6/2003	Cribier
8,343,213	B2	1/2013	Salahieh et al.	2003/0109930	A1	6/2003	Bluni et al.
8,376,865	B2	2/2013	Forster et al.	2003/0114912	A1	6/2003	Sequin et al.
8,377,117	B2	2/2013	Keidar et al.	2003/0114913	A1	6/2003	Spenser et al.
8,398,708	B2	3/2013	Meiri et al.	2003/0125795	A1	7/2003	Pavcnik et al.
8,579,962	B2	11/2013	Salahieh et al.	2003/0130729	A1	7/2003	Paniagua et al.
8,603,160	B2	12/2013	Salahieh et al.	2003/0135257	A1	7/2003	Taheri
8,617,236	B2	12/2013	Paul et al.	2003/0144732	A1	7/2003	Cosgrove et al.
8,623,076	B2	1/2014	Salahieh et al.	2003/0149475	A1	8/2003	Hyodoh et al.
8,623,078	B2	1/2014	Salahieh et al.	2003/0149476	A1	8/2003	Damm et al.
8,668,733	B2	3/2014	Haug et al.	2003/0149478	A1	8/2003	Figulla et al.
8,828,078	B2	9/2014	Salahieh et al.	2003/0153974	A1	8/2003	Spenser et al.
8,840,662	B2	9/2014	Salahieh et al.	2003/0171803	A1	9/2003	Shimon
8,840,663	B2	9/2014	Salahieh et al.	2003/0176884	A1	9/2003	Berrada et al.
8,858,620	B2	10/2014	Salahieh et al.	2003/0181850	A1	9/2003	Diamond et al.
2001/0002445	A1	5/2001	Vesely	2003/0187495	A1	10/2003	Cully et al.
2001/0007956	A1	7/2001	Letac et al.	2003/0191516	A1	10/2003	Weldon et al.
2001/0010017	A1	7/2001	Letac et al.	2003/0195609	A1	10/2003	Berenstein et al.
2001/0021872	A1*	9/2001	Bailey et al. .... 623/1.24	2003/0199759	A1	10/2003	Richard
2001/0025196	A1	9/2001	Chinn et al.	2003/0199913	A1	10/2003	Dubrul et al.
2001/0032013	A1	10/2001	Marton	2003/0199971	A1	10/2003	Tower et al.
2001/0039450	A1	11/2001	Pavcnik et al.	2003/0199972	A1	10/2003	Zadno-Azizi et al.
2001/0041928	A1	11/2001	Pavcnik et al.	2003/0208224	A1	11/2003	Broome
2001/0041930	A1	11/2001	Globerman et al.	2003/0212429	A1	11/2003	Keegan et al.
2001/0044634	A1	11/2001	Don Michael et al.	2003/0212452	A1	11/2003	Zadno-Azizi et al.
2001/0044652	A1	11/2001	Moore	2003/0212454	A1	11/2003	Scott et al.
2001/0044656	A1	11/2001	Williamson et al.	2003/0216774	A1	11/2003	Larson
2002/0002396	A1	1/2002	Fulkerson	2003/0225445	A1	12/2003	Derus et al.
2002/0010489	A1	1/2002	Grayzel et al.	2003/0229390	A1	12/2003	Ashton et al.
2002/0026233	A1	2/2002	Shaknovich	2003/0233117	A1	12/2003	Adams et al.
2002/0029014	A1	3/2002	Jayaraman	2004/0019374	A1	1/2004	Hojeibane et al.
2002/0029981	A1	3/2002	Nigam	2004/0034411	A1	2/2004	Quijano et al.
2002/0032480	A1	3/2002	Spence et al.	2004/0039436	A1	2/2004	Spenser et al.
2002/0032481	A1	3/2002	Gabbay	2004/0049224	A1	3/2004	Buehlmann et al.
2002/0042651	A1	4/2002	Liddicoat et al.	2004/0049226	A1	3/2004	Keegan et al.
2002/0052651	A1	5/2002	Myers et al.	2004/0049262	A1	3/2004	Obermiller et al.
2002/0055767	A1	5/2002	Forde et al.	2004/0049266	A1	3/2004	Anduiza et al.
2002/0055769	A1	5/2002	Wang	2004/0059409	A1	3/2004	Stenzel
2002/0058995	A1	5/2002	Stevens	2004/0073198	A1	4/2004	Gilson et al.
2002/0077696	A1	6/2002	Zadno-Azizi et al.	2004/0082904	A1	4/2004	Houde et al.
2002/0082609	A1	6/2002	Green	2004/0082967	A1	4/2004	Broome et al.
2002/0095173	A1	7/2002	Mazzocchi et al.	2004/0087982	A1	5/2004	Eskuri et al.
2002/0095209	A1	7/2002	Zadno-Azizi et al.	2004/0088045	A1	5/2004	Cox
2002/0111674	A1	8/2002	Chouinard et al.	2004/0093016	A1	5/2004	Root et al.
2002/0120328	A1	8/2002	Pathak et al.	2004/0093060	A1	5/2004	Seguin et al.
2002/0123802	A1	9/2002	Snyders	2004/0097788	A1	5/2004	Mourlas et al.
2002/0138138	A1	9/2002	Yang	2004/0098022	A1	5/2004	Barone
2002/0151970	A1	10/2002	Garrison et al.	2004/0098098	A1	5/2004	McGuckin, Jr. et al.
2002/0161390	A1	10/2002	Mouw	2004/0098099	A1	5/2004	McCullagh et al.
2002/0161392	A1	10/2002	Dubrul	2004/0098112	A1	5/2004	DiMatteo et al.
2002/0161394	A1	10/2002	Macoviak et al.	2004/0107004	A1	6/2004	Levine et al.
2002/0165576	A1	11/2002	Boyle et al.	2004/0111096	A1	6/2004	Tu et al.
2002/0177766	A1	11/2002	Mogul	2004/0116951	A1	6/2004	Rosengart
2002/0183781	A1	12/2002	Casey et al.	2004/0117004	A1	6/2004	Osborne et al.
2002/0188341	A1	12/2002	Elliott	2004/0117009	A1	6/2004	Cali et al.
2002/0188344	A1	12/2002	Bolea et al.	2004/0122468	A1	6/2004	Yodfat et al.
2002/0193871	A1	12/2002	Beyersdorf et al.	2004/0122516	A1	6/2004	Fogarty et al.
2003/0014104	A1	1/2003	Cribier	2004/0127936	A1	7/2004	Salahieh et al.
				2004/0127979	A1	7/2004	Wilson et al.
				2004/0133274	A1	7/2004	Webler et al.
				2004/0138694	A1	7/2004	Tran et al.
				2004/0138742	A1	7/2004	Myers et al.

(56)

References Cited

U.S. PATENT DOCUMENTS

2004/0138743	A1	7/2004	Myers et al.	2005/0137697	A1	6/2005	Salahieh et al.
2004/0148018	A1	7/2004	Carpentier et al.	2005/0137698	A1	6/2005	Salahieh et al.
2004/0148021	A1	7/2004	Cartledge et al.	2005/0137699	A1	6/2005	Salahieh et al.
2004/0153094	A1	8/2004	Dunfee et al.	2005/0137701	A1	6/2005	Salahieh et al.
2004/0158277	A1	8/2004	Lowe et al.	2005/0137702	A1	6/2005	Haug et al.
2004/0167565	A1	8/2004	Beulke et al.	2005/0143807	A1	6/2005	Pavcnik et al.
2004/0167620	A1	8/2004	Ortiz et al.	2005/0143809	A1	6/2005	Salahieh et al.
2004/0181140	A1	9/2004	Falwell et al.	2005/0149159	A1	7/2005	Andreas et al.
2004/0186558	A1	9/2004	Pavcnik et al.	2005/0165352	A1	7/2005	Henry et al.
2004/0186563	A1	9/2004	Lobbi	2005/0165477	A1	7/2005	Anduiza et al.
2004/0193261	A1	9/2004	Berrekouw	2005/0165479	A1	7/2005	Drewns et al.
2004/0199245	A1	10/2004	Lauterjung	2005/0182486	A1	8/2005	Gabbay
2004/0204755	A1	10/2004	Robin	2005/0197694	A1	9/2005	Pai et al.
2004/0210304	A1	10/2004	Seguin et al.	2005/0197695	A1	9/2005	Stacchino et al.
2004/0210306	A1	10/2004	Quijano et al.	2005/0203549	A1	9/2005	Realyvasquez
2004/0210307	A1	10/2004	Khairkahan	2005/0203614	A1	9/2005	Forster
2004/0215331	A1	10/2004	Chew et al.	2005/0203615	A1	9/2005	Forster
2004/0215333	A1	10/2004	Duran et al.	2005/0203616	A1	9/2005	Cribier
2004/0215339	A1	10/2004	Drasler et al.	2005/0203617	A1	9/2005	Forster et al.
2004/0220655	A1	11/2004	Swanson et al.	2005/0203618	A1	9/2005	Sharkawy et al.
2004/0225321	A1	11/2004	Krolik et al.	2005/0209580	A1	9/2005	Freyman
2004/0225353	A1	11/2004	McGuckin, Jr. et al.	2005/0228472	A1	10/2005	Case et al.
2004/0225354	A1	11/2004	Allen et al.	2005/0228495	A1	10/2005	Macoviak
2004/0225355	A1	11/2004	Stevens	2005/0234546	A1	10/2005	Nugent et al.
2004/0243221	A1	12/2004	Fawzi et al.	2005/0240200	A1	10/2005	Bergheim
2004/0254636	A1	12/2004	Flagle et al.	2005/0240262	A1	10/2005	White
2004/0260390	A1	12/2004	Sarac et al.	2005/0251250	A1	11/2005	Verhoeven et al.
2005/0010287	A1	1/2005	Macoviak et al.	2005/0251251	A1	11/2005	Cribier
2005/0021136	A1	1/2005	Xie et al.	2005/0261759	A1	11/2005	Lambrecht et al.
2005/0033398	A1	2/2005	Seguin	2005/0267560	A1	12/2005	Bates
2005/0033402	A1	2/2005	Cully et al.	2005/0283231	A1	12/2005	Haug et al.
2005/0043711	A1	2/2005	Corcoran et al.	2005/0283962	A1	12/2005	Boudjemline
2005/0043757	A1	2/2005	Arad et al.	2006/0004439	A1	1/2006	Spenser et al.
2005/0043790	A1	2/2005	Seguin	2006/0004442	A1	1/2006	Spenser et al.
2005/0049692	A1	3/2005	Numamoto et al.	2006/0015168	A1	1/2006	Gunderson
2005/0049696	A1	3/2005	Siess et al.	2006/0058872	A1	3/2006	Salahieh et al.
2005/0055088	A1	3/2005	Liddicoat et al.	2006/0149360	A1	7/2006	Schwammenthal et al.
2005/0060016	A1	3/2005	Wu et al.	2006/0155312	A1	7/2006	Levine et al.
2005/0060029	A1	3/2005	Le et al.	2006/0161249	A1	7/2006	Realyvasquez et al.
2005/0065594	A1	3/2005	DiMatteo et al.	2006/0173524	A1	8/2006	Salahieh et al.
2005/0075584	A1	4/2005	Cali	2006/0195183	A1	8/2006	Navia et al.
2005/0075662	A1	4/2005	Pedersen et al.	2006/0253191	A1	11/2006	Salahieh et al.
2005/0075712	A1	4/2005	Biancucci et al.	2006/0259134	A1	11/2006	Schwammenthal et al.
2005/0075717	A1	4/2005	Nguyen et al.	2006/0271166	A1	11/2006	Thill et al.
2005/0075719	A1	4/2005	Bergheim	2006/0287668	A1	12/2006	Fawzi et al.
2005/0075724	A1	4/2005	Svanidze et al.	2006/0287717	A1	12/2006	Rowe et al.
2005/0075730	A1	4/2005	Myers et al.	2007/0010876	A1	1/2007	Salahieh et al.
2005/0075731	A1*	4/2005	Artof et al. .... 623/2.18	2007/0010877	A1	1/2007	Salahieh et al.
2005/0085841	A1	4/2005	Eversull et al.	2007/0016286	A1	1/2007	Herrmann et al.
2005/0085842	A1	4/2005	Eversull et al.	2007/0055340	A1	3/2007	Pryor
2005/0085843	A1	4/2005	Opolski et al.	2007/0061008	A1	3/2007	Salahieh et al.
2005/0085890	A1	4/2005	Rasmussen et al.	2007/0112355	A1	5/2007	Salahieh et al.
2005/0090846	A1	4/2005	Pedersen et al.	2007/0118214	A1	5/2007	Salahieh et al.
2005/0090890	A1	4/2005	Wu et al.	2007/0162107	A1	7/2007	Haug et al.
2005/0096692	A1	5/2005	Linder et al.	2007/0173918	A1	7/2007	Dreher et al.
2005/0096734	A1	5/2005	Majercak et al.	2007/0203503	A1	8/2007	Salahieh et al.
2005/0096735	A1	5/2005	Hojeibane et al.	2007/0244552	A1	10/2007	Salahieh et al.
2005/0096736	A1	5/2005	Osse et al.	2007/0288089	A1	12/2007	Gurskis et al.
2005/0096738	A1	5/2005	Cali et al.	2008/0009940	A1	1/2008	Cribier
2005/0100580	A1	5/2005	Osborne et al.	2008/0033541	A1	2/2008	Gelbart et al.
2005/0107822	A1	5/2005	WasDyke	2008/0082165	A1	4/2008	Wilson et al.
2005/0113910	A1	5/2005	Paniagua et al.	2008/0125859	A1	5/2008	Salahieh et al.
2005/0131438	A1	6/2005	Cohn	2008/0188928	A1	8/2008	Salahieh et al.
2005/0137683	A1	6/2005	Hezi-Yamit et al.	2008/0208328	A1	8/2008	Antocci et al.
2005/0137686	A1	6/2005	Salahieh et al.	2008/0208332	A1	8/2008	Lamphere et al.
2005/0137687	A1	6/2005	Salahieh et al.	2008/0221672	A1	9/2008	Lamphere et al.
2005/0137688	A1	6/2005	Salahieh et al.	2008/0234814	A1	9/2008	Salahieh et al.
2005/0137689	A1	6/2005	Salahieh et al.	2008/0255661	A1	10/2008	Straubinger et al.
2005/0137690	A1	6/2005	Salahieh et al.	2008/0269878	A1	10/2008	Iobbi
2005/0137691	A1	6/2005	Salahieh et al.	2008/0288054	A1	11/2008	Pulnev et al.
2005/0137692	A1	6/2005	Haug et al.	2009/0005863	A1	1/2009	Goetz et al.
2005/0137693	A1	6/2005	Haug et al.	2009/0030512	A1	1/2009	Thielen et al.
2005/0137694	A1	6/2005	Haug et al.	2009/0054969	A1	2/2009	Salahieh et al.
2005/0137695	A1	6/2005	Salahieh et al.	2009/0076598	A1	3/2009	Salahieh et al.
2005/0137696	A1	6/2005	Salahieh et al.	2009/0093877	A1	4/2009	Keidar et al.
				2009/0171456	A1	7/2009	Kveen et al.
				2009/0222076	A1	9/2009	Figulla et al.
				2009/0264759	A1	10/2009	Byrd
				2009/0264997	A1	10/2009	Salahieh et al.

(56)

References Cited

U.S. PATENT DOCUMENTS

2009/0299462	A1	12/2009	Fawzi et al.
2010/0049313	A1	2/2010	Alon et al.
2010/0094399	A1	4/2010	Dorn et al.
2010/0121434	A1	5/2010	Paul et al.
2010/0191326	A1	7/2010	Alkhatib
2010/0219092	A1	9/2010	Salahieh et al.
2010/0280495	A1	11/2010	Paul et al.
2011/0257735	A1	10/2011	Salahieh et al.
2012/0022642	A1	1/2012	Haug et al.
2012/0029627	A1	2/2012	Salahieh et al.
2012/0041550	A1	2/2012	Salahieh et al.
2012/0053683	A1	3/2012	Salahieh et al.
2012/0089224	A1	4/2012	Haug et al.
2012/0330409	A1	12/2012	Haug et al.
2013/0018457	A1	1/2013	Gregg et al.
2013/0030520	A1	1/2013	Lee et al.
2013/0158656	A1	6/2013	Sutton et al.
2013/0190865	A1	7/2013	Anderson
2013/0304199	A1	11/2013	Sutton et al.
2014/0018911	A1	1/2014	Zhou et al.
2014/0094904	A1	4/2014	Salahieh et al.
2014/0114405	A1	4/2014	Paul et al.
2014/0114406	A1	4/2014	Salahieh et al.
2014/0121766	A1	5/2014	Salahieh et al.
2014/0135912	A1	5/2014	Salahieh et al.
2014/0243967	A1	8/2014	Salahieh et al.

FOREIGN PATENT DOCUMENTS

DE	19546692	6/1997
DE	19857887	7/2000
DE	19907646	8/2000
DE	10049812	4/2002
DE	10049813	4/2002
DE	10049814	4/2002
DE	10049815	4/2002
EP	0103546	5/1988
EP	0144167	11/1989
EP	0409929	B1 4/1997
EP	0850607	7/1998
EP	0597967	12/1999
EP	1000590	A1 5/2000
EP	1057459	12/2000
EP	1057460	12/2000
EP	1088529	4/2001
EP	0937439	B1 9/2003
EP	1340473	A2 9/2003
EP	1356793	10/2003
EP	1042045	B1 5/2004
EP	0819013	6/2004
EP	1435879	7/2004
EP	1439800	7/2004
EP	1472996	11/2004
EP	1229864	B1 4/2005
EP	1430853	A2 6/2005
EP	1059894	B1 7/2005
EP	1551274	7/2005
EP	1551336	7/2005
EP	1078610	B1 8/2005
EP	1562515	8/2005
EP	1570809	9/2005
EP	1576937	A2 9/2005
EP	1582178	A2 10/2005
EP	1582179	A2 10/2005
EP	1469797	11/2005
EP	1589902	11/2005
EP	1600121	A1 11/2005
EP	1156757	B1 12/2005
EP	1616531	1/2006
EP	1605871	7/2008
FR	2788217	7/2000
GB	2056023	3/1981
GB	2398245	8/2004
SU	1271508	11/1986

SU	1371700	2/1988
WO	9117720	11/1991
WO	9217118	10/1992
WO	9301768	2/1993
WO	93/15693	8/1993
WO	95/04556	2/1995
WO	95/29640	11/1995
WO	96/14032	5/1996
WO	96/24306	A1 8/1996
WO	96/40012	12/1996
WO	9829057	7/1998
WO	98/36790	8/1998
WO	98/50103	A1 11/1998
WO	98/57599	A2 12/1998
WO	9933414	7/1999
WO	9940964	8/1999
WO	9947075	9/1999
WO	99/44542	A2 9/1999
WO	00/09059	2/2000
WO	0041652	7/2000
WO	0044311	8/2000
WO	0045874	8/2000
WO	0047139	8/2000
WO	00/44308	8/2000
WO	00/44313	8/2000
WO	00/49970	A1 8/2000
WO	00/67661	11/2000
WO	01/05331	1/2001
WO	01/08596	A1 2/2001
WO	01/10320	A1 2/2001
WO	01/10343	A1 2/2001
WO	01/35870	5/2001
WO	0149213	7/2001
WO	0154625	8/2001
WO	0162189	8/2001
WO	01/64137	9/2001
WO	01/76510	A2 10/2001
WO	0197715	12/2001
WO	02/36048	5/2002
WO	02/41789	A2 5/2002
WO	0243620	6/2002
WO	0247575	6/2002
WO	02056955	7/2002
WO	02/100297	12/2002
WO	03/003943	1/2003
WO	03/003949	1/2003
WO	03/011195	2/2003
WO	03/030776	A2 4/2003
WO	03047648	6/2003
WO	03094793	11/2003
WO	03/015851	11/2003
WO	03/094797	11/2003
WO	2004006803	1/2004
WO	2004006804	1/2004
WO	2004/014256	A1 2/2004
WO	2004019817	3/2004
WO	2004021922	3/2004
WO	2004/019811	3/2004
WO	2004/023980	3/2004
WO	2004/026117	A2 4/2004
WO	2004043293	5/2004
WO	2004/041126	5/2004
WO	2004/047681	A1 6/2004
WO	2004058106	7/2004
WO	2004/066876	A1 8/2004
WO	2004/082536	A1 9/2004
WO	2004089250	10/2004
WO	2004089253	10/2004
WO	2004093728	11/2004
WO	2004105651	12/2004
WO	2005002466	1/2005
WO	2005004753	1/2005
WO	2005004753	1/2005
WO	2005009285	2/2005
WO	2005011534	2/2005
WO	2005011535	2/2005
WO	2005023155	3/2005
WO	2005027790	3/2005
WO	2005046528	5/2005
WO	2005046529	5/2005

(56)

## References Cited

## FOREIGN PATENT DOCUMENTS

WO	2005048883	6/2005
WO	2005062980	7/2005
WO	2005065585	7/2005
WO	WO 2005/084595 A1	9/2005
WO	WO 2005/087140 A1	9/2005
WO	2005096993	10/2005
WO	2006/005015 A2	1/2006
WO	2006009690	1/2006
WO	2006027499	3/2006
WO	2006138391	12/2006
WO	2007033093	3/2007
WO	2007035471	3/2007
WO	2007044285	4/2007
WO	2007053243	5/2007
WO	2007058847	5/2007
WO	2007092354	8/2007
WO	2007097983	8/2007
WO	2010042950	4/2010

## OTHER PUBLICATIONS

Paul et al.; U.S. Appl. No. 12/578,447 entitled "Medical Devices and Delivery Systems for Delivering Medical Devices," filed Oct. 13, 2009.

Salahieh et al.; U.S. Appl. No. 12/777,161 entitled "Two-Part Package for Medical Implant," filed May 10, 2010.

Andersen, H.R. et al. "Transluminal implantation of artificial heart valves. Description of a new expandable aortic valve and initial results with implantation by catheter technique in closed chest pigs." *Euro. Heart J.* 1992; 13:704-708.

Atwood, A. et al. "Insertion of Heart Valves by Catheterization." Project Supervised by Prof. S. Muftu of Northeastern University 2001-2002: 36-40.

Bodnar, E. et al. *Replacement Cardiac Valves R Chapter 13: Extinct cardiac valve prostheses.* Pergamon Publishing Corporation. New York, 1991: 307-322.

Boudjemline, Y. et al. Percutaneous implantation of a biological valve in the aorta to treat aortic valve insufficiency—a sheep study. *f Med Sci. Monit.* 2002; vol. 8, No. 4: BR113-116.

Boudjemline, Y. et al. "Percutaneous implantation of a valve in the descending aorta in lambs." *Euro. Heart J.* 2002; 23: 1045-1049.

Boudjemline, Y. et al. "Percutaneous pulmonary valve replacement in a large right ventricular outflow tract: an experimental study." *Journal of the American College of Cardiology.* 2004; vol. 43(6): 1082-1087.

Boudjemline, Y. et al. "Percutaneous valve insertion: A new approach?" *J. of Thoracic and Cardio. Surg.* 2003; 125(3): 741-743.

Boudjemline, Y. et al. "Steps Toward Percutaneous Aortic Valve Replacement." *Circulation.* 2002; 105: 775-778.

Cribier, A. et al. "Early Experience with Percutaneous Transcatheter Implantation of Heart Valve Prosthesis for the Treatment of End-Stage Inoperable Patients with Calcific Aortic Stenosis." *J. of Am. Coll. of Cardio.* 2004; 43(4): 698-703.

Cribier, A., et al. "Percutaneous Transcatheter Implantation of an Aortic Valve Prosthesis for Calcific Aortic Stenosis: First Human Case Description." *Circulation.* 2002; 106: 3006-3008.

Cribier, A., et al. "Percutaneous Transcatheter Implantation of an Aortic Valve Prosthesis for Calcific Aortic Stenosis: First Human Case." *Percutaneous Valve Technologies, Inc.* 2002: 16 pages.

Ferrari, M. et al. "Percutaneous transvascular aortic valve replacement with self expanding stent-valve device." Poster from the presentation given at SMIT 2000, 12th International Conference. Sep. 5, 2000.

Hijazi, Z.M. "Transcatheter Valve Replacement: A New Era of Percutaneous Cardiac Intervention Begins." *J. of Am. College of Cardio.* 2004; 43(6): 1088-1089.

Huber, C.H. et al. "Do valved stents compromise coronary flow?" *European Journal of Cardio-thoracic Surgery.* 2004; vol. 25: 754-759.

Knudsen, L. L. et al. "Catheter-implanted prosthetic heart valves." *Int'l J. of Art. Organs.* 1993; 16(5): 253-262.

Kort, S. et al. "Minimally invasive aortic valve replacement: Echocardiographic and clinical results." *Am. Heart J.* 2001; 142(3): 476-481.

Love, C. et al. fThe Autogenous Tissue Heart Valve: Current Stat.f *Journal of Cardiac Surgery.* 1991; 6(4): 499-507.

Lutter, G. et al. "Percutaneous aortic valve replacement: An experimental study. I. Studies on implantation." *J. of Thoracic and Cardio. Surg.* 2002; 123(4): 768-776.

Moulopoulos, S. D. et al. "Catheter-Mounted Aortic Valves." *Annals of Thoracic Surg.* 1971; 11(5): 423-430.

Paniagua, D. et al. "Percutaneous heart valve in the chronic in vitro testing model." *Circulation.* 2002; 106: e51-e52.

Paniagua, D. et al. *Heart Watch (2004).* Texas Heart Institute. Spring, 2004 Edition: 8 pages.

Pavcnik, D. et al. "Percutaneous bioprosthetic veno valve: A long-term study in sheep." *J. of Vascular Surg.* 2002; 35(3): 598-603.

Phillips, S. J. et al. "A Temporary Catheter-Tip Aortic Valve: Hemodynamic Effects on Experimental Acute Aortic Insufficiency." *Annals of Thoracic Surg.* 1976; 21(2): 134-136.

Sochman, J. et al. "Percutaneous Transcatheter Aortic Disc Valve Prosthesis Implantation: A Feasibility Study." *Cardiovasc. Intervent. Radiol.* 2000; 23: 384-388.

Stuart, M. "In Heart Valves, A Brave, New Non-Surgical World." *Start-Up.* 2004: 9-17.

Vahanian, A. et al. "Percutaneous Approaches to Valvular Disease." *Circulation.* 2004; 109: 1572-1579.

Van Herwerden, L. A. et al., "Percutaneous valve implantation: back to the future?" *Euro. Heart J.* 2002; 23(18): 1415-1416.

Zhou, J. Q. et al. "Self-expandable valved stent of large size: off-bypass implantation in pulmonary position." *Eur. J. Cardiothorac.* 2003; 24: 212-216.

Examiner's First Report on AU Patent Application No. 2011202667, issued on May 17, 2012.

A Matter of Size, Triennial Review of the National Nanotechnology Initiative, 2006, v-13, The National Academies Press, Washington, DC <http://www.nap.edu/catalog/11752.html>.

Atwood, A. et al., "Insertion of Heart Valves by Catheterization". The Capstone Design Course Report. MIME 1501-1502. Technical Design Report. Northeastern University. Nov. 5, 2007, pp. 1-93.

Aug. 19, 2011, Supplemental Search Report from EP Patent office, EP Application No. 04813777.2.

Aug. 19, 2011, Supplemental Search Report from EP Patent office, EP Application No. 04815634.3.

Cunanan, Crystal, M., M.S., et al., Tissue Characterization and Calcification Potential of Commercial Bioprosthetic Heart Valves, *Ann Thorac Surg*, 2001, S417-21.

Cunliffe, H.R. et al., Glutaraldehyde Inactivation of Exotic Animal Viruses in Swine Heart Tissue, *May 1979, 1044-1046, vol. 37, No. 5., Applied and Environmental Microbiology*, Greenport, New York.

EP Search Report mailed Aug. 10, 2011 for EP Application No. 06824992.9.

Heart Valve Materials—Bovine (cow), Equine & Porcine Pericardium, Maverick Biosciences Pty. Ltd, 2009, <http://www.maverickbio.com/biological-medical-device-materials.php?htm>.

Helmus, M.N., Mechanical and bioprosthetic heart valves in biomaterials for artificial organs, 114-162, Woodhead Publishing Limited, 2011.

Houriham, Maribeth, et al., Transcatheter Umbrella Closure of Valvular and Paravalvular Leaks, *Nov. 15, 1992, 1371-7, vol. 20, No. 6, JACC, Boston Massachusetts.*

Laborde, J.C. et al., Percutaneous implantation of the corevalve aortic valve prosthesis for patients presenting high risk for surgical valve replacement, 2006, 472-474, *EuroIntervention.*

Levy, Charles, M.D., Mycobacterium Chelonae Infection of Porcine Heart Valves, *Sep. 22, 1977, vol. 297, No. 12, The New England Journal of Medicine, Washington, D.C.*

Oct. 24, 2011, Supplemental Search Report from EP Patent office, EP Application No. 05758878.2.

Pericardial Heart Valves, Edwards Lifesciences, Cardiovascular Surgery FAQ, *Nov. 14, 2010, <http://www.edwards.com/products/cardiovascularsurgeryfaq.htm>.*

Southern Lights Biomaterials Homepage, *Jan. 7, 2011, <http://www.slv.co.nz/>.*

(56)

**References Cited**

OTHER PUBLICATIONS

Stassano, Paolo, Mid-term results of the valve-on-valve technique for bioprosthetic failure, 2000, 453-457, European Journal of Cardiothoracic Surgery.

Topol, Eric J., M.D., Percutaneous Expandable Prosthetic Valves, Textbook of Interventional Cardiology, 1994, 1268-1276, vol. 2, W.B. Saunders Company, Philadelphia.

\* cited by examiner

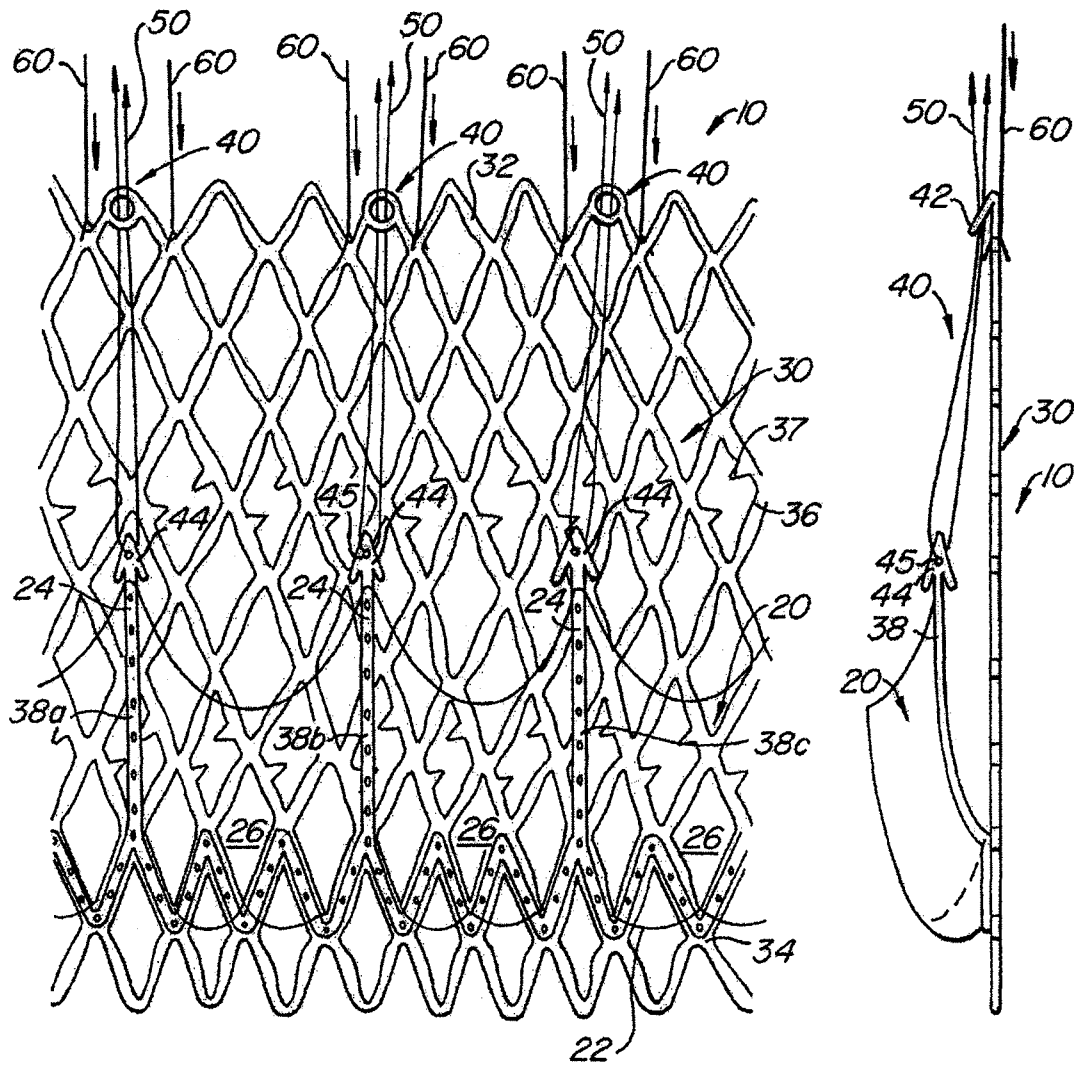

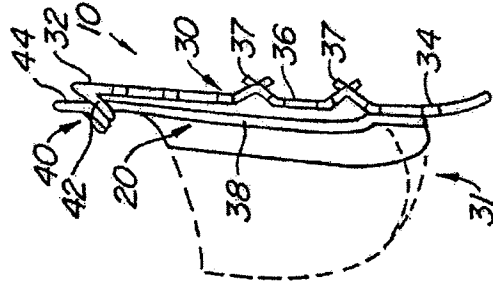

FIG. 2B

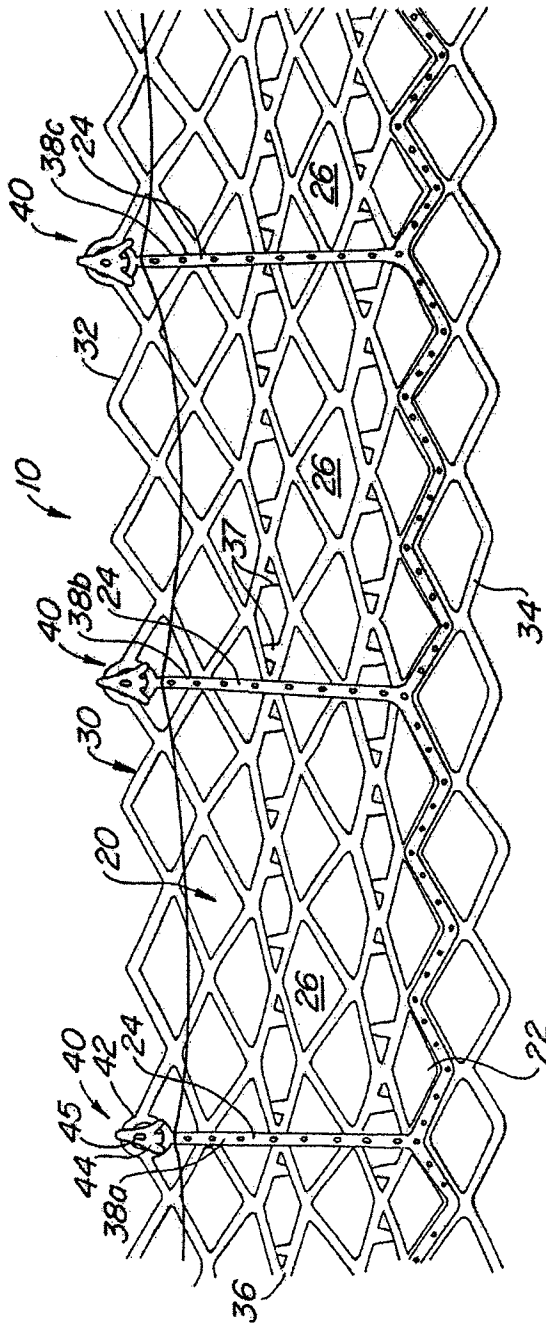

FIG. 1B

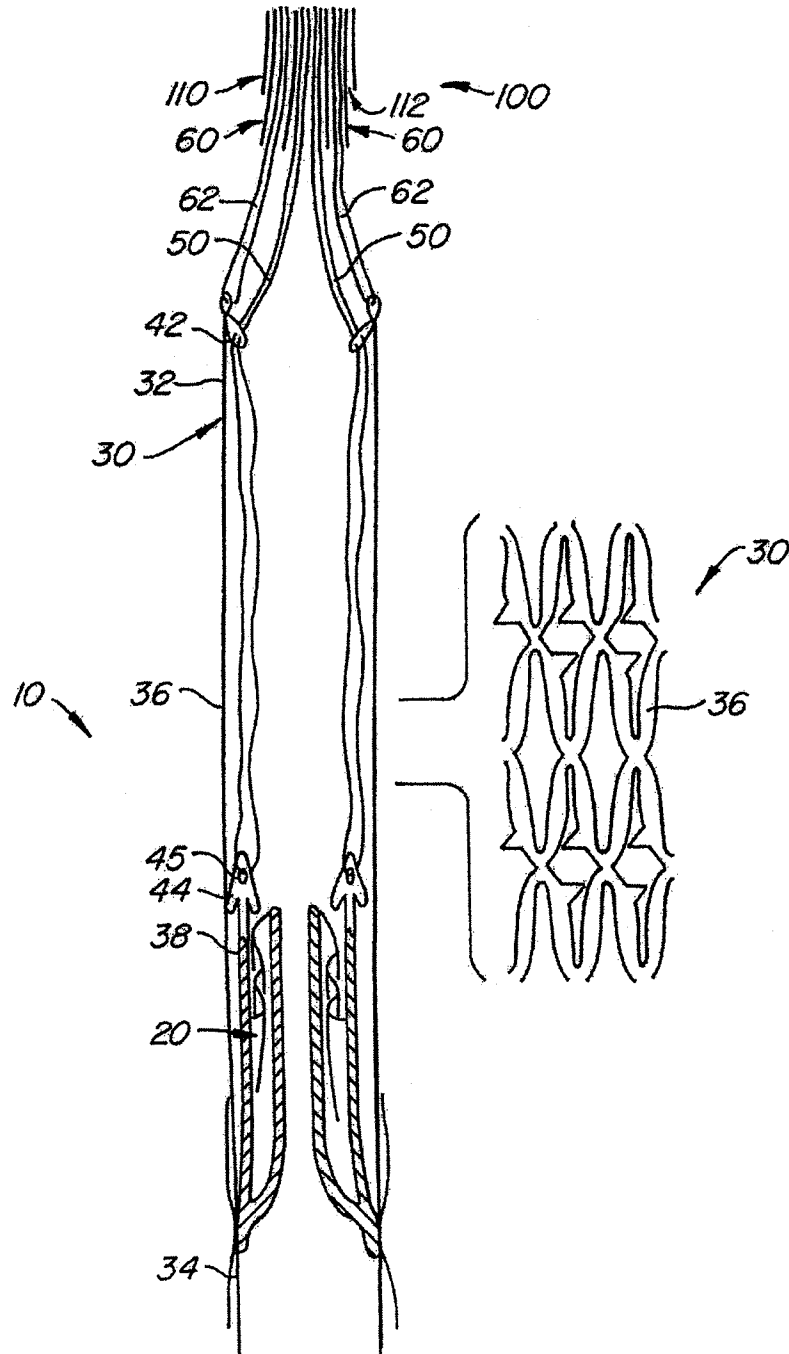

FIG. 3A



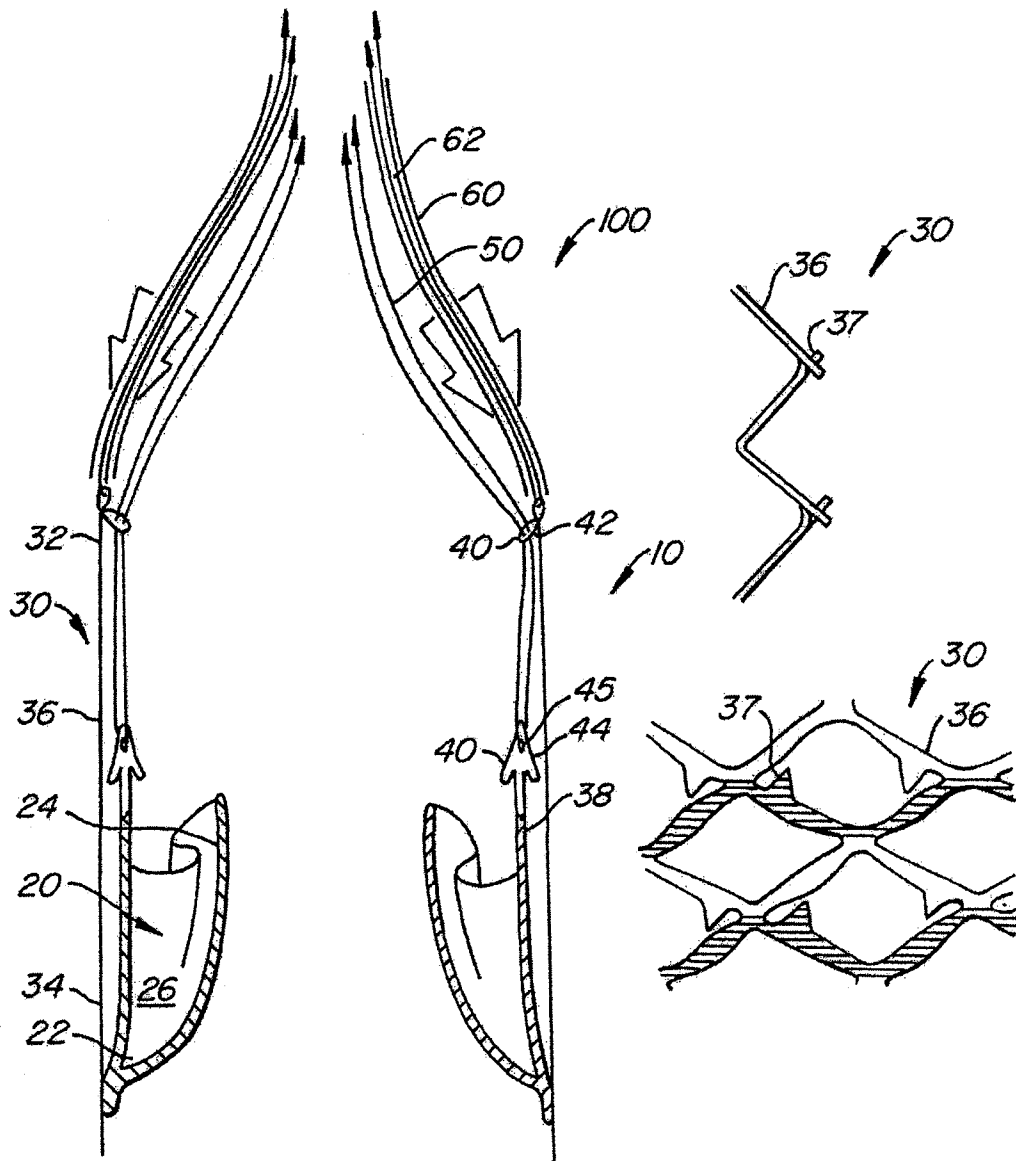

FIG. 3B

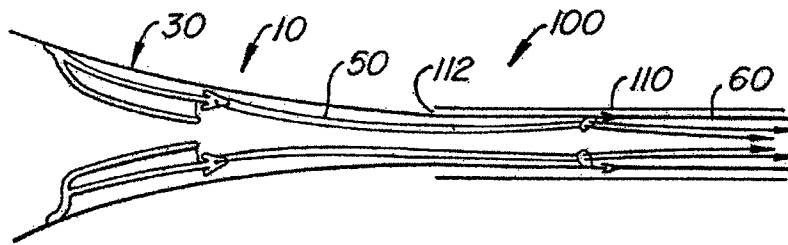

FIG. 4A

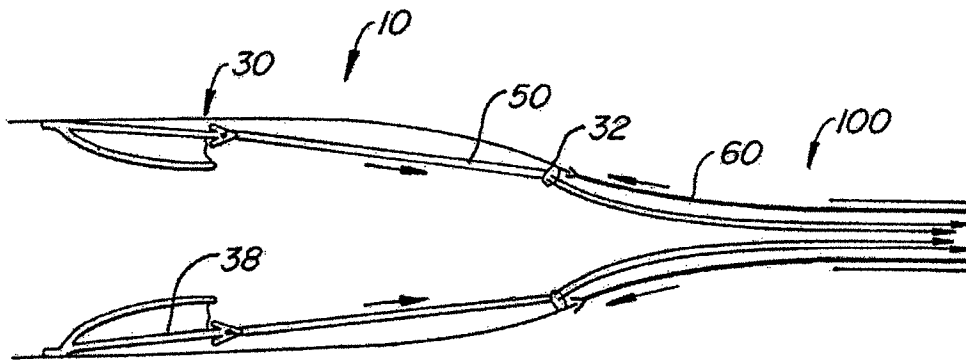

FIG. 4B

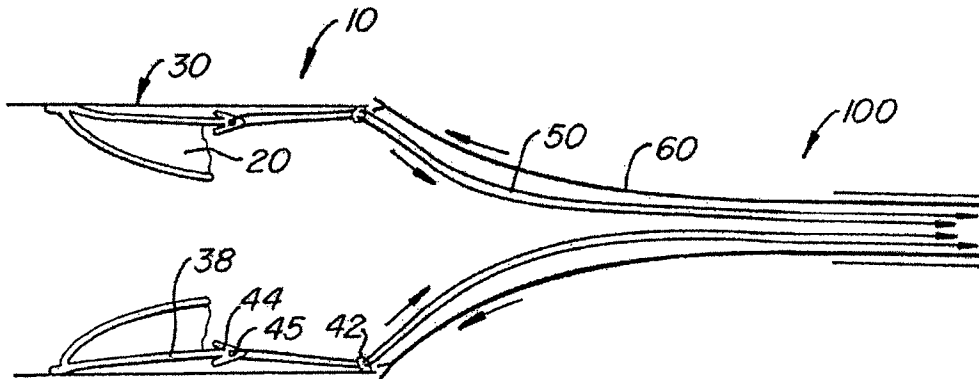

FIG. 4C

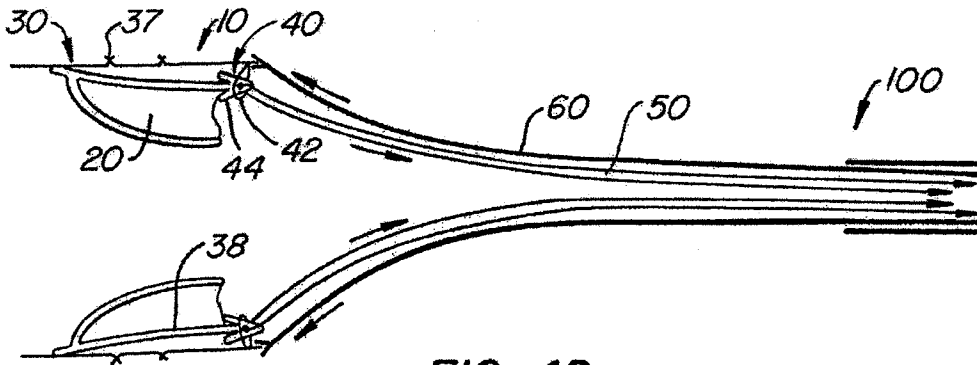

FIG. 4D

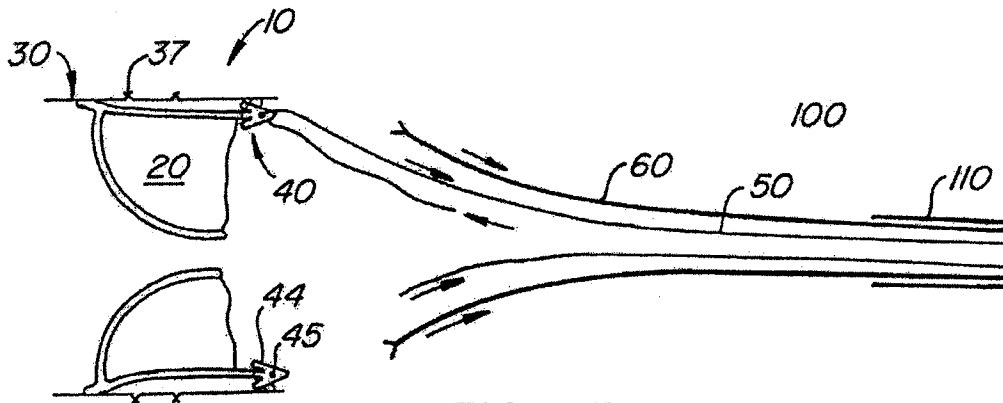

FIG. 4E

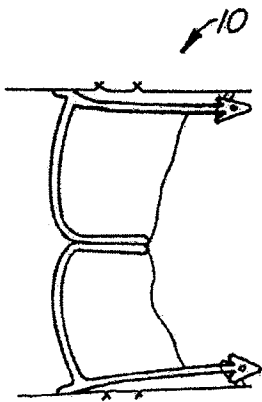

FIG. 4F

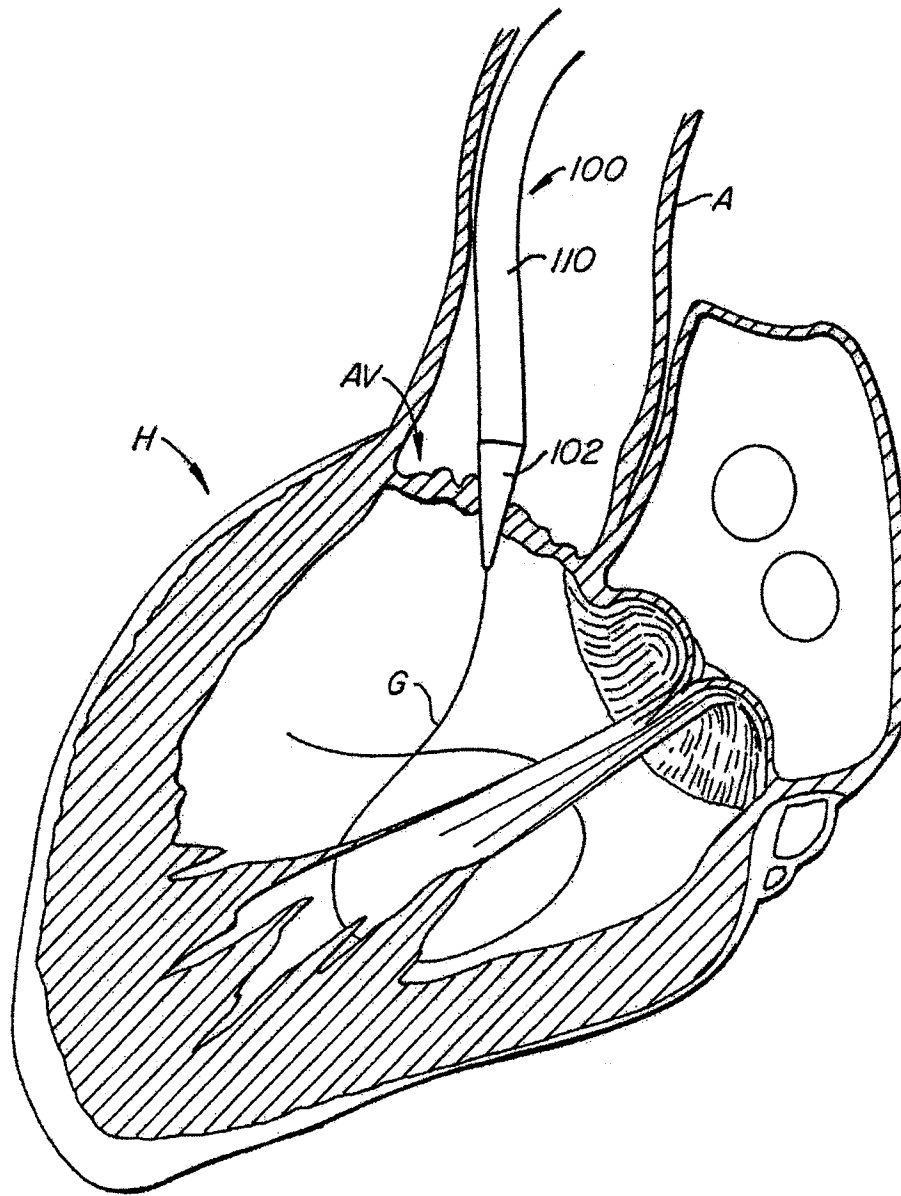

FIG. 5A

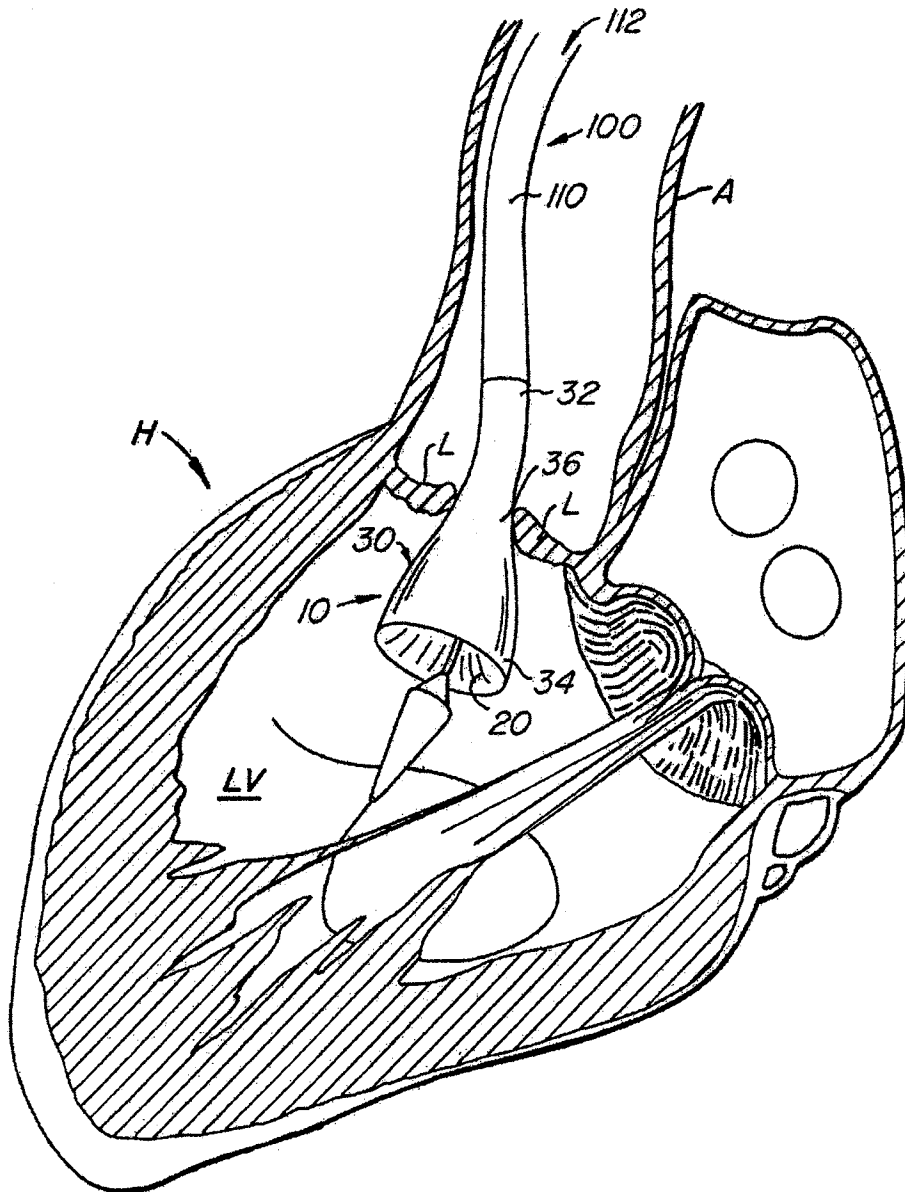

FIG. 5B

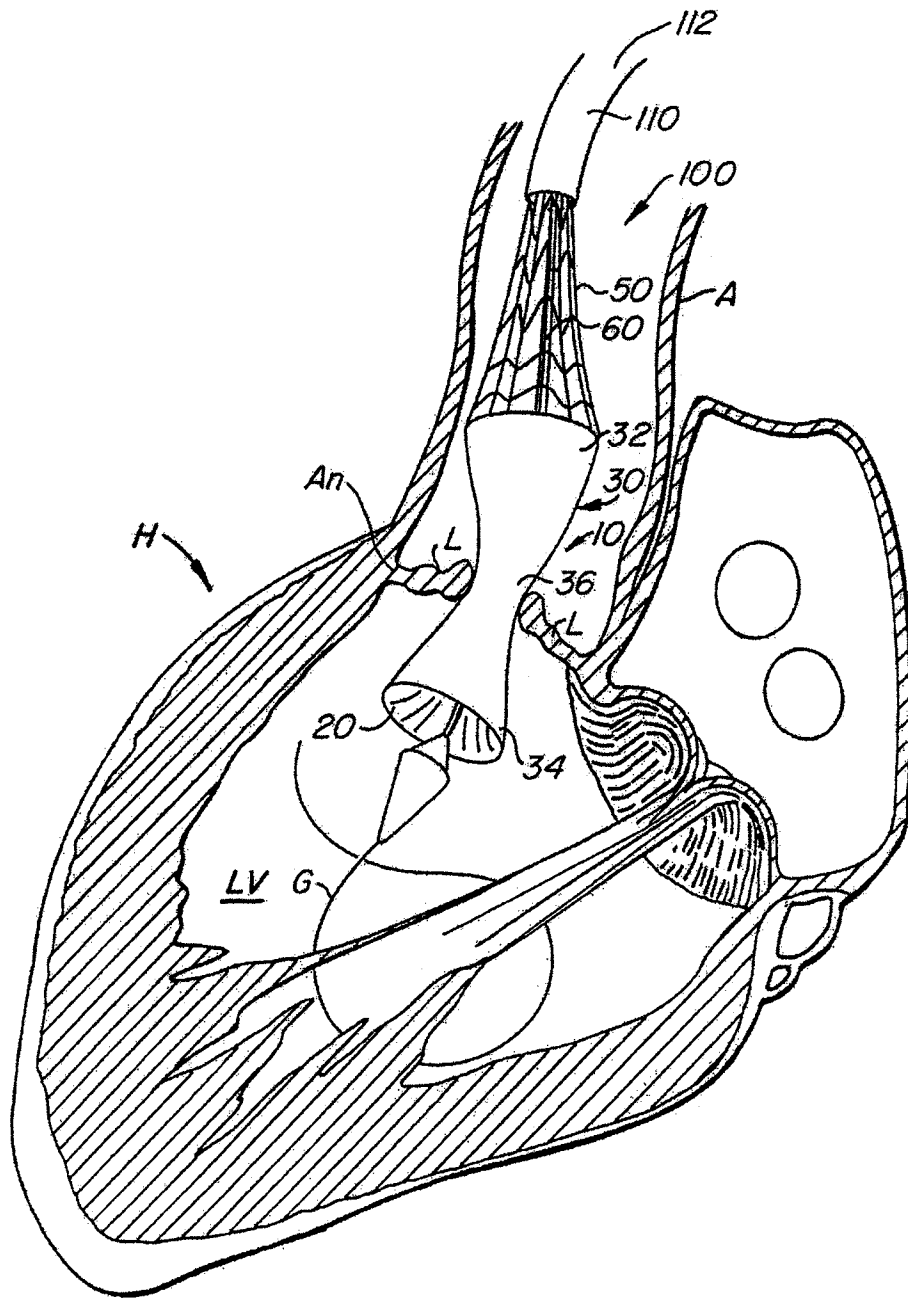

FIG. 5C

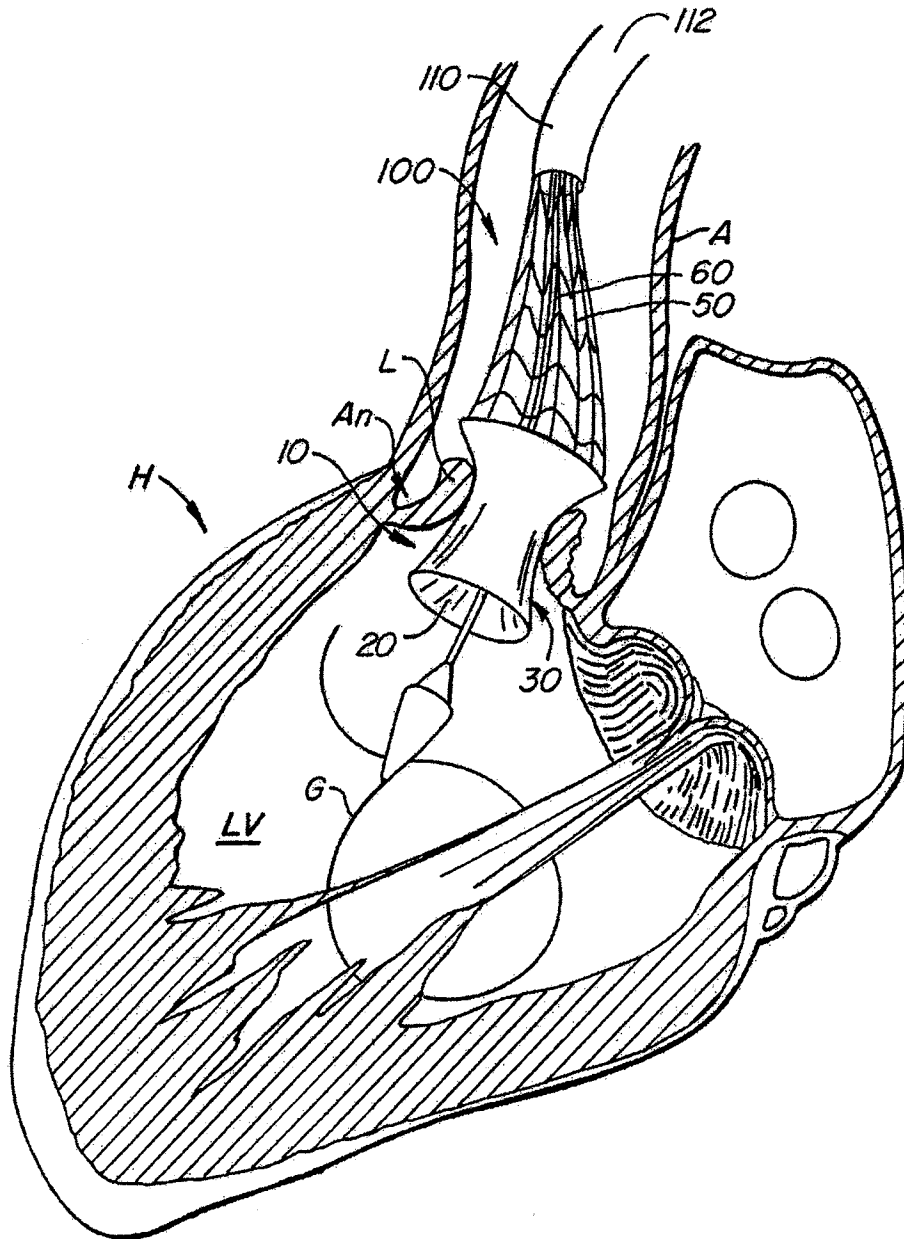

FIG. 5D

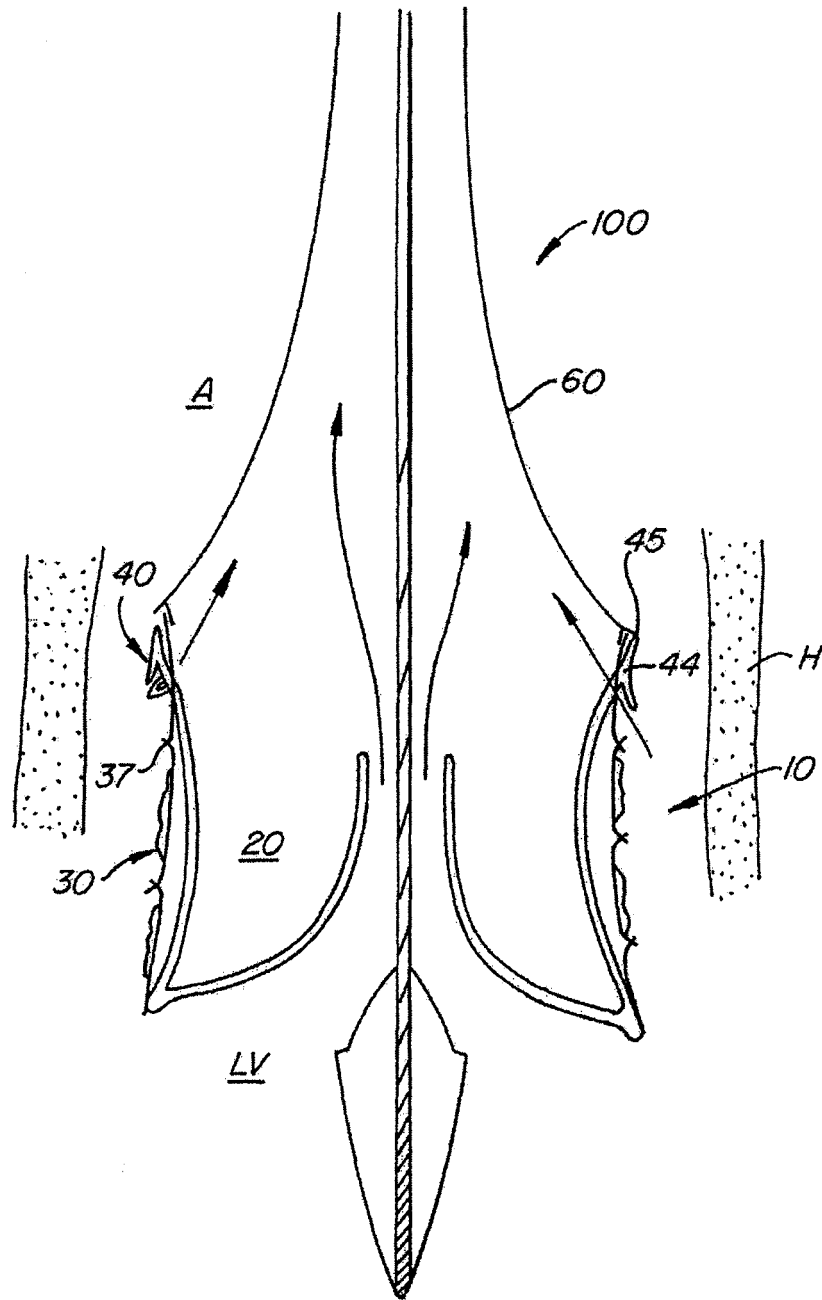

FIG. 5E



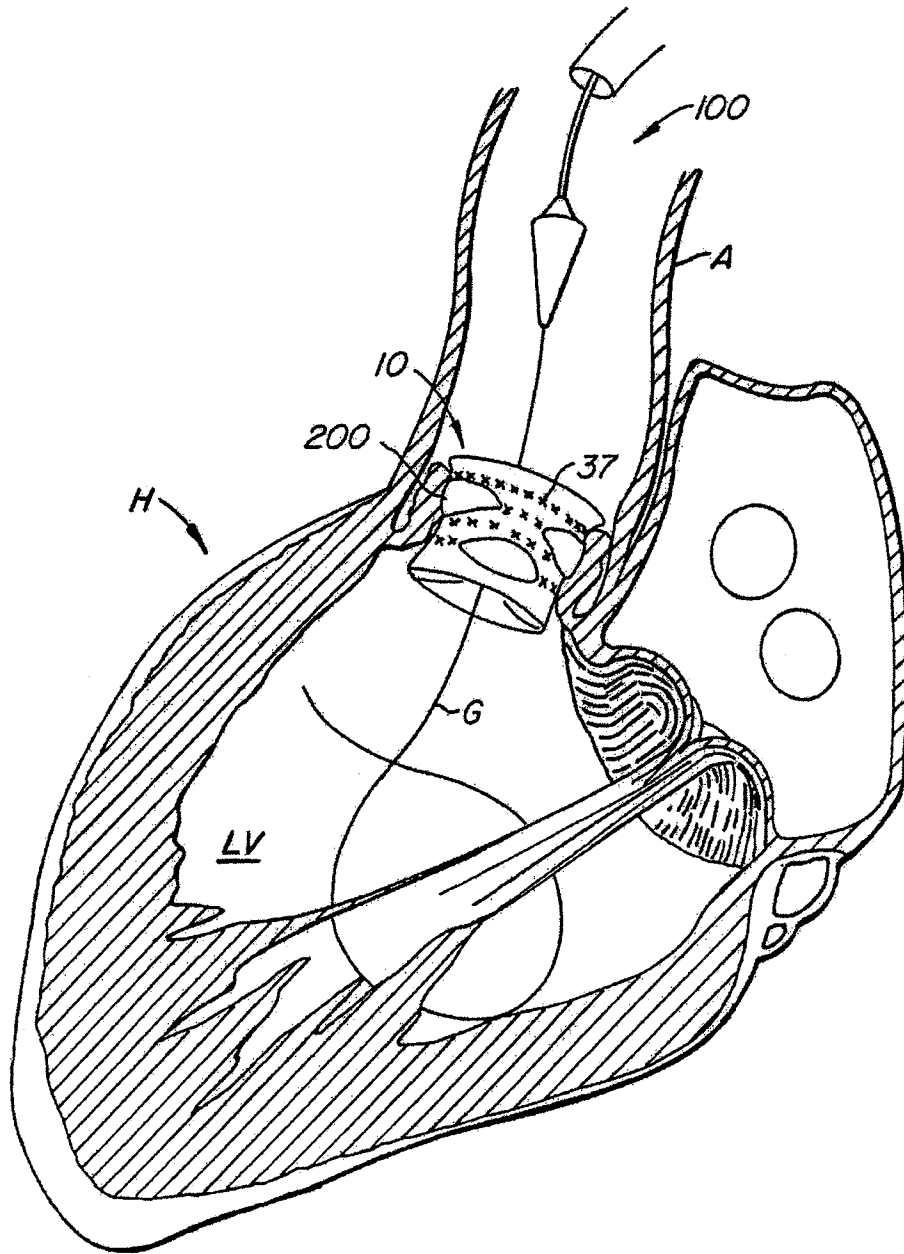

FIG. 5F

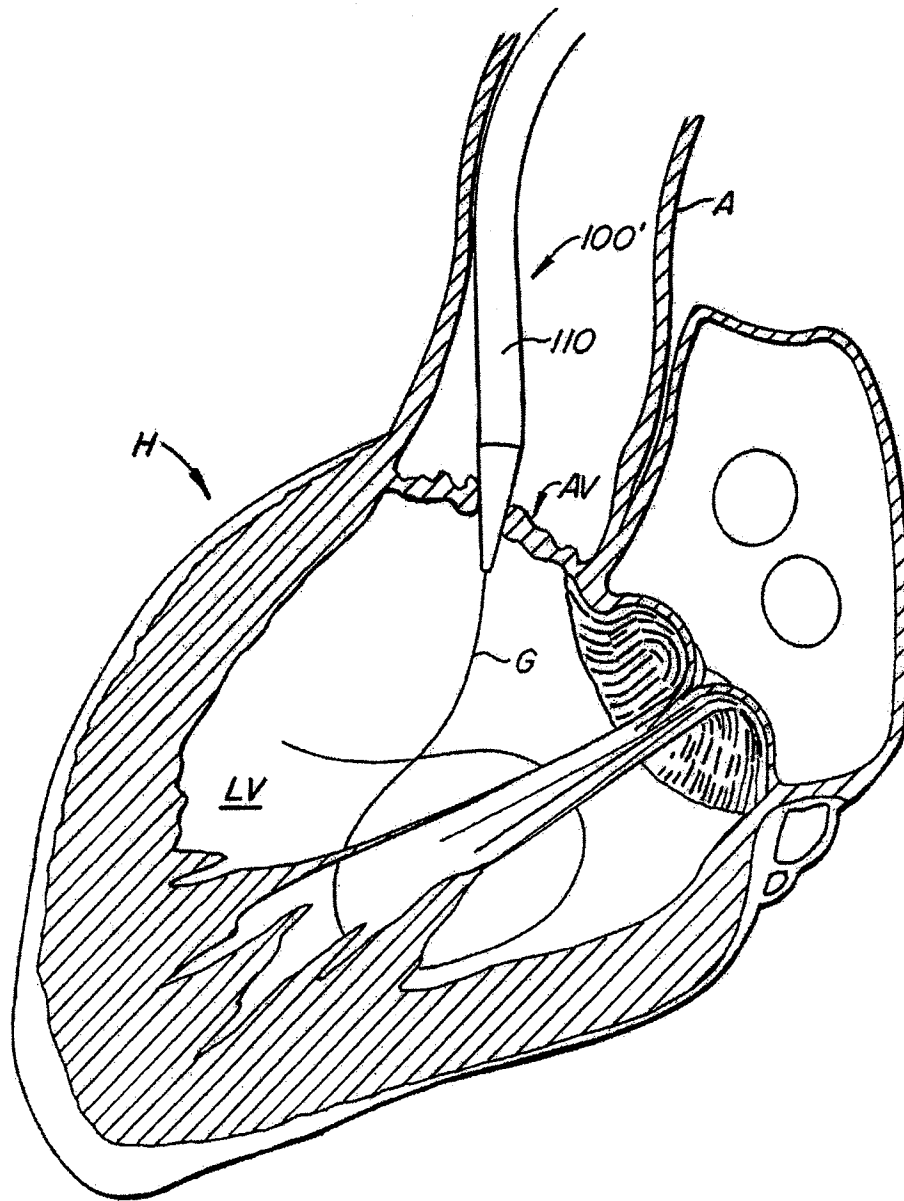

FIG. 6A

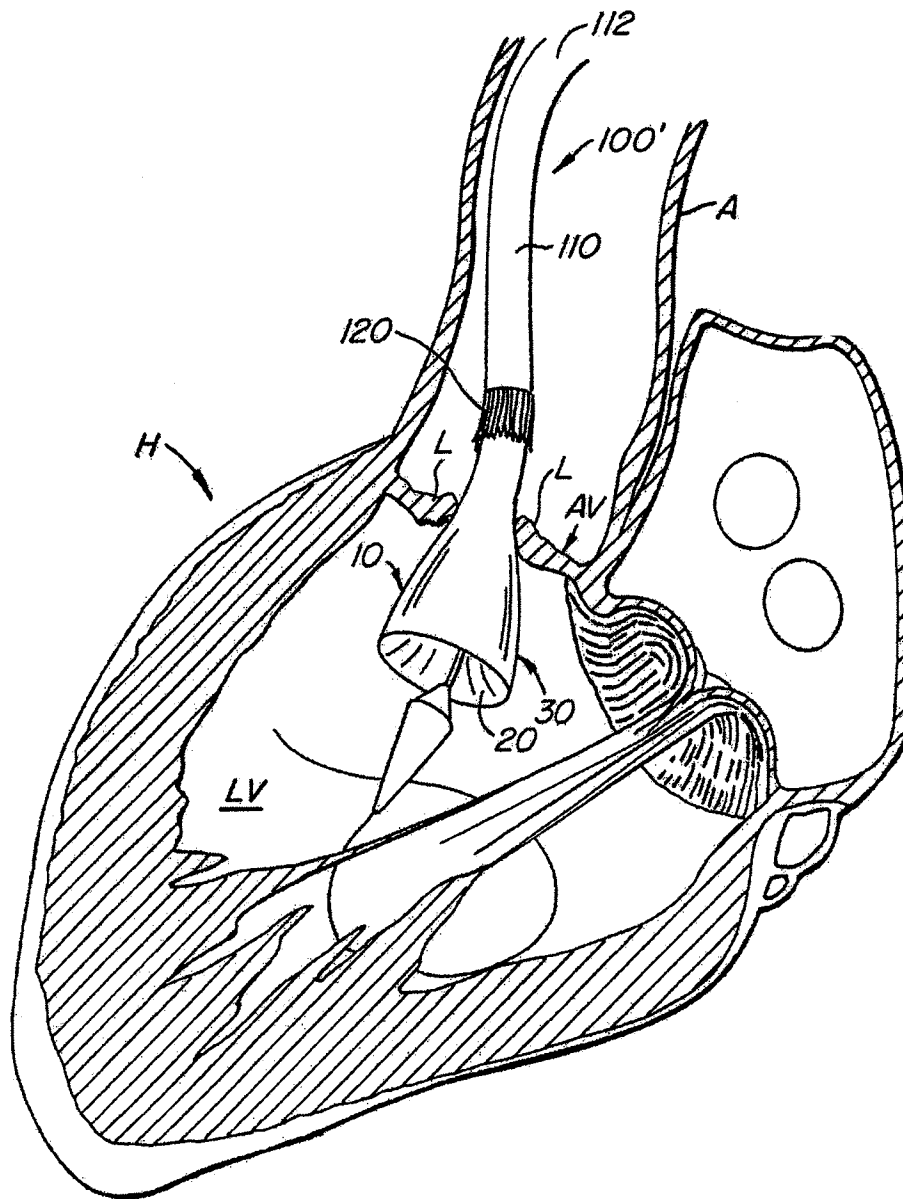

FIG. 6B

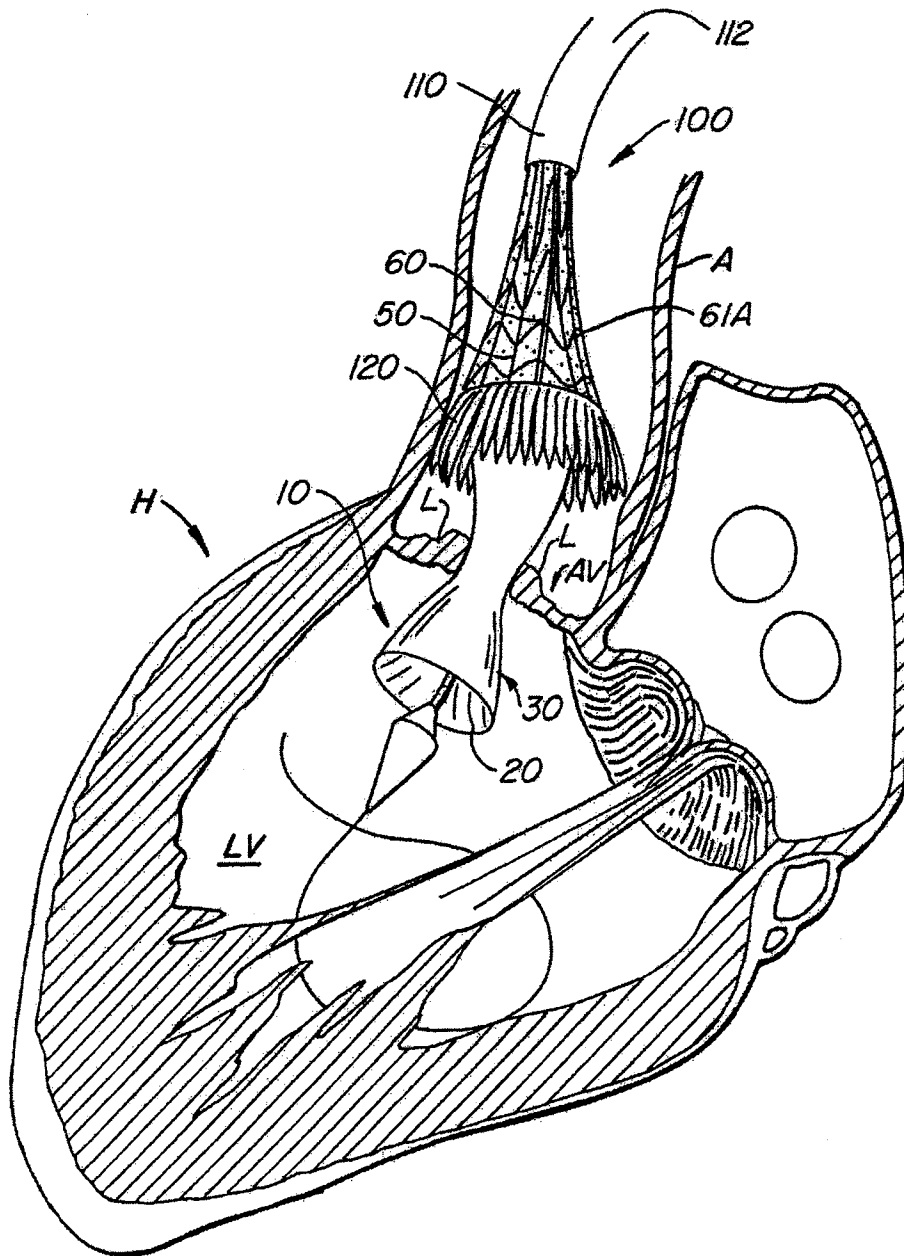

FIG. 6C

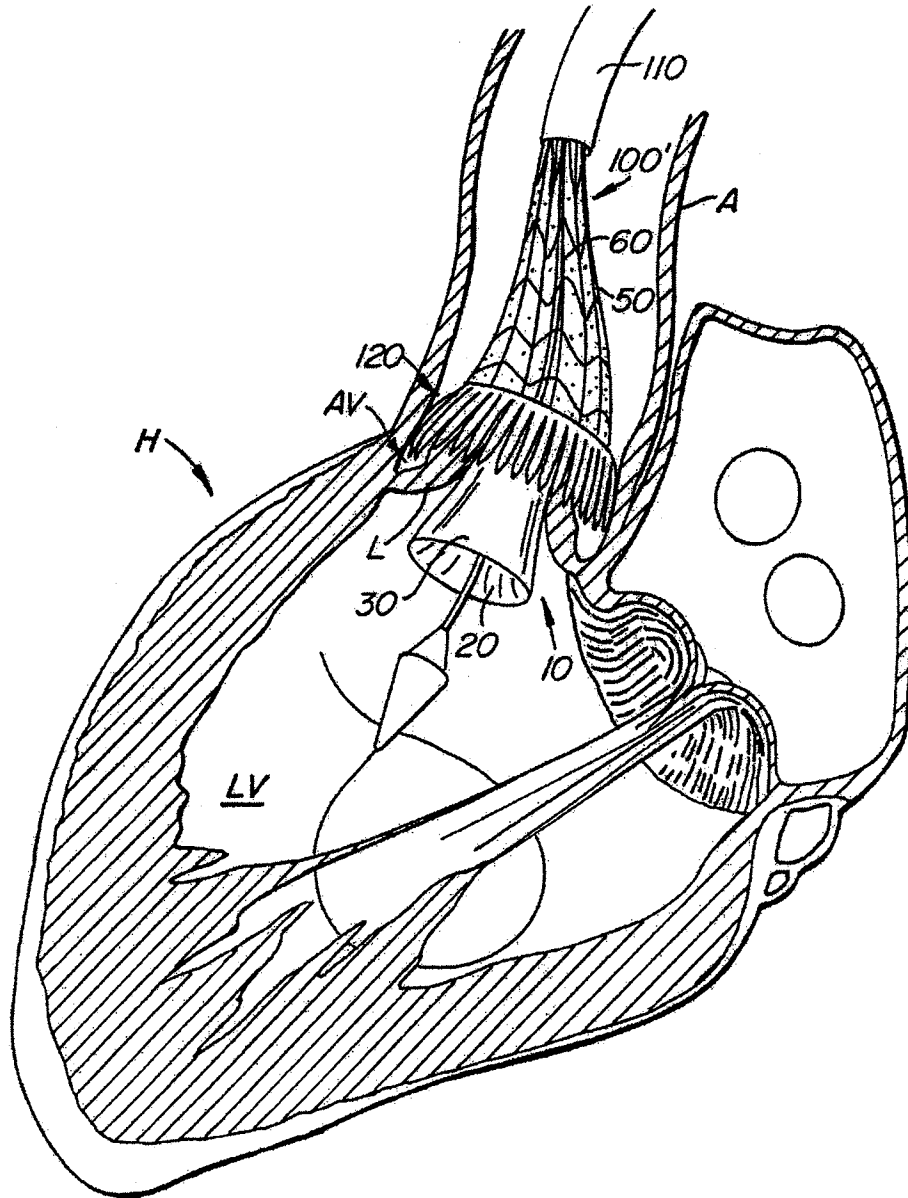

FIG. 6D

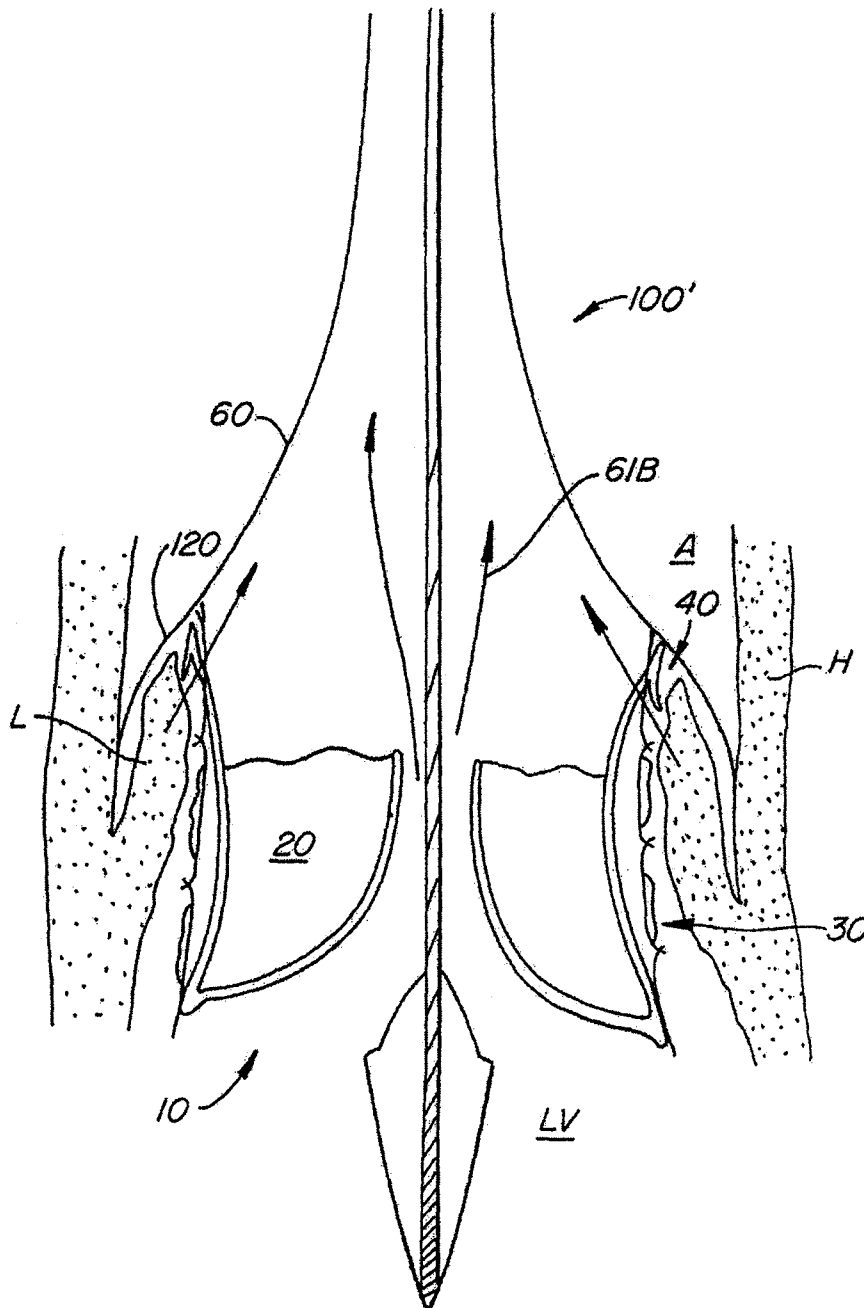

FIG. 6E

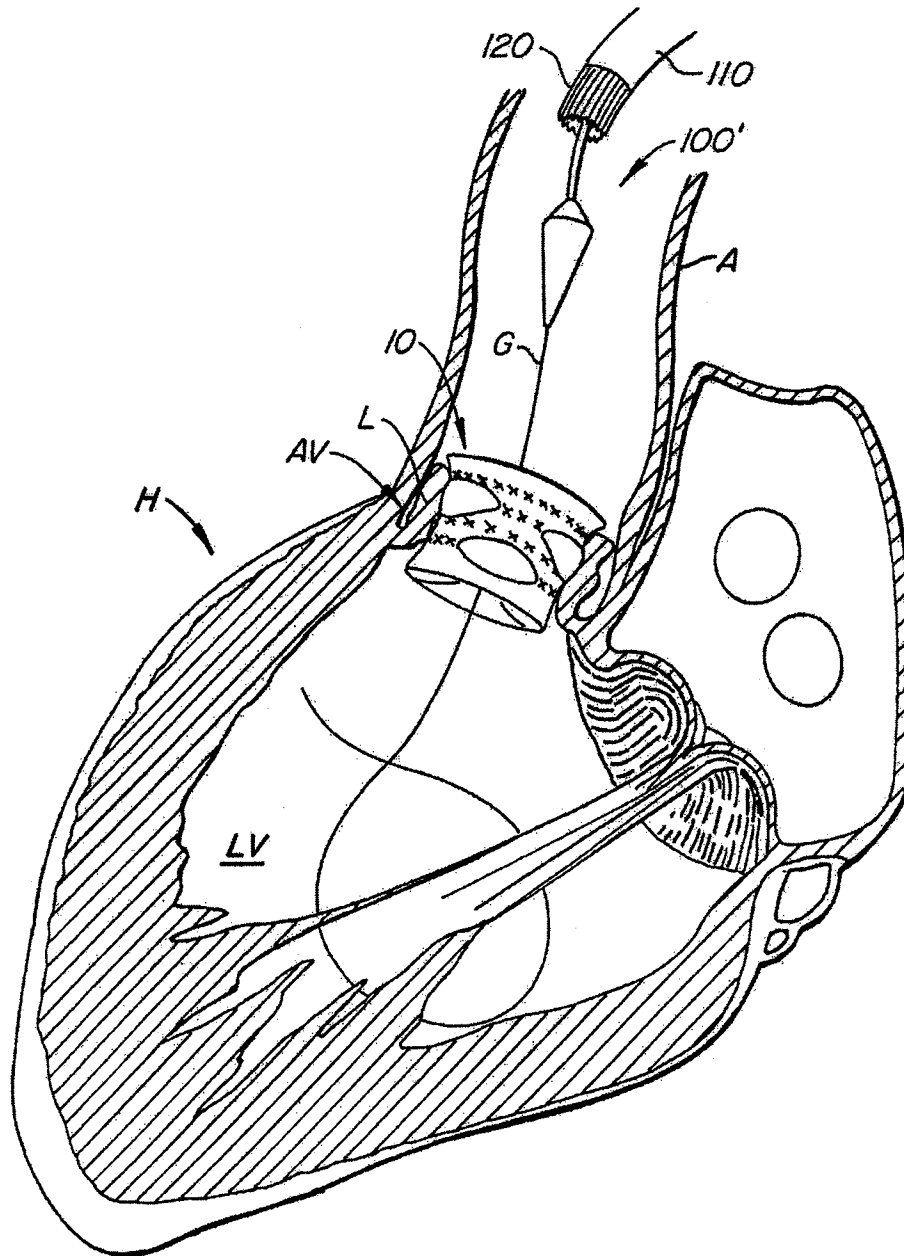

FIG. 6F

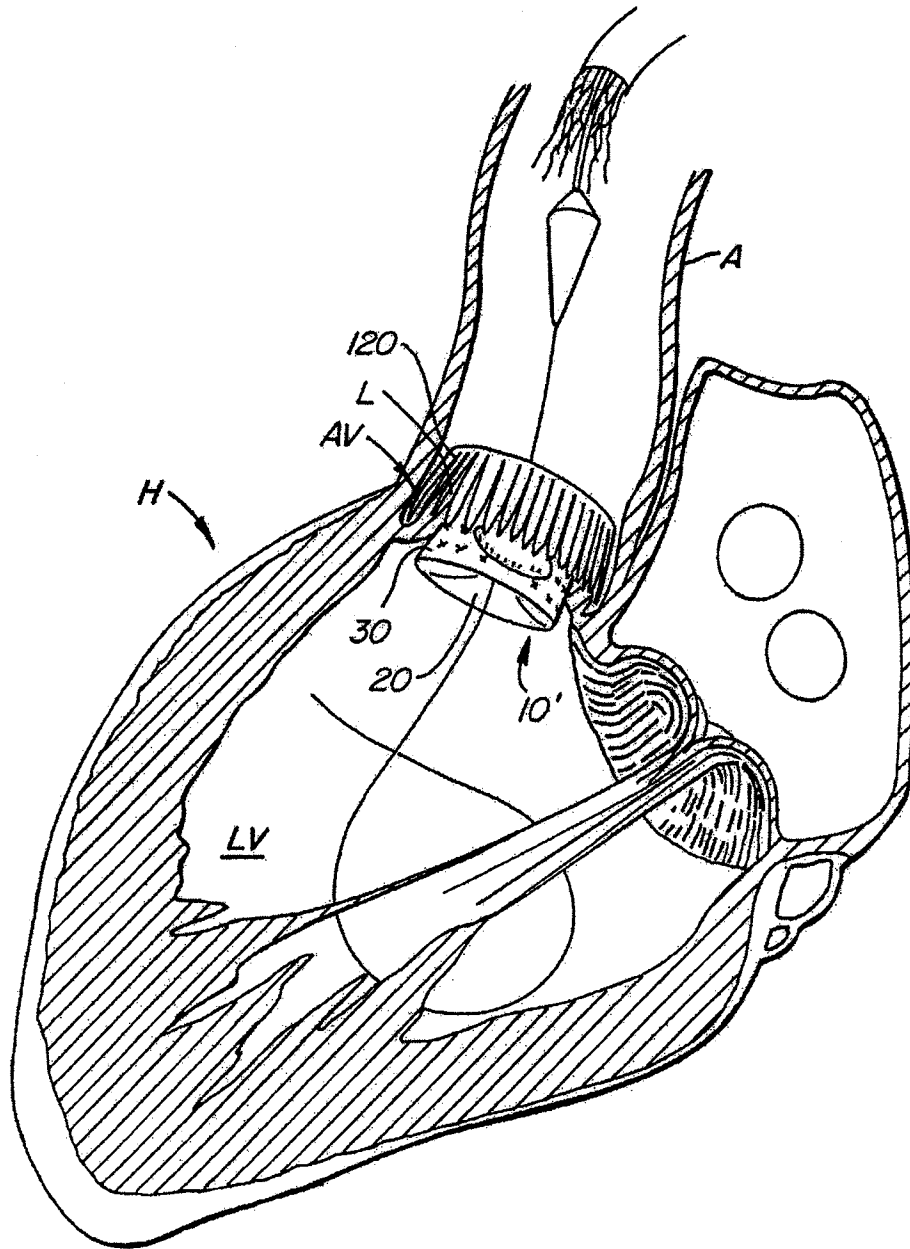
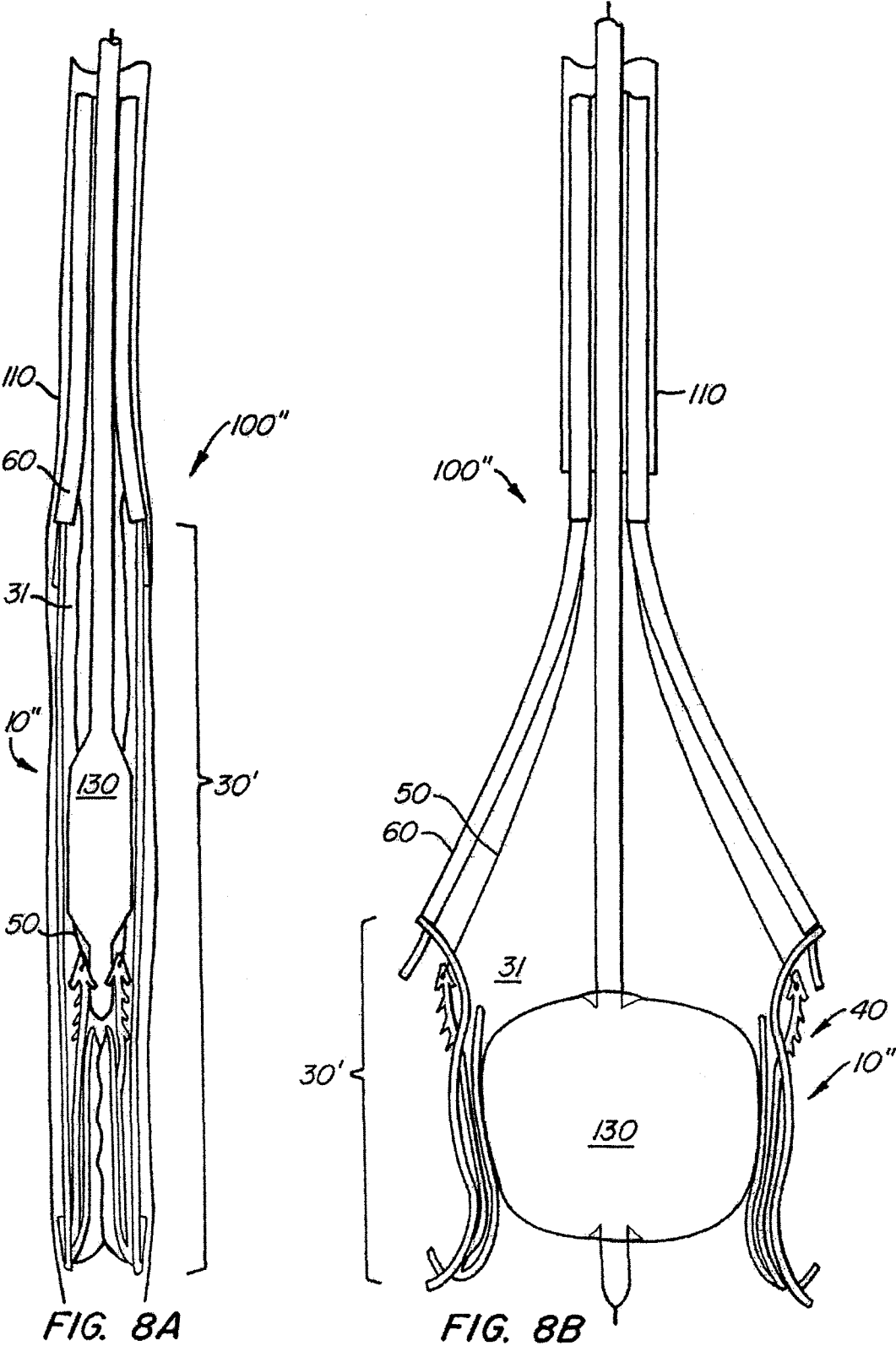

FIG. 7





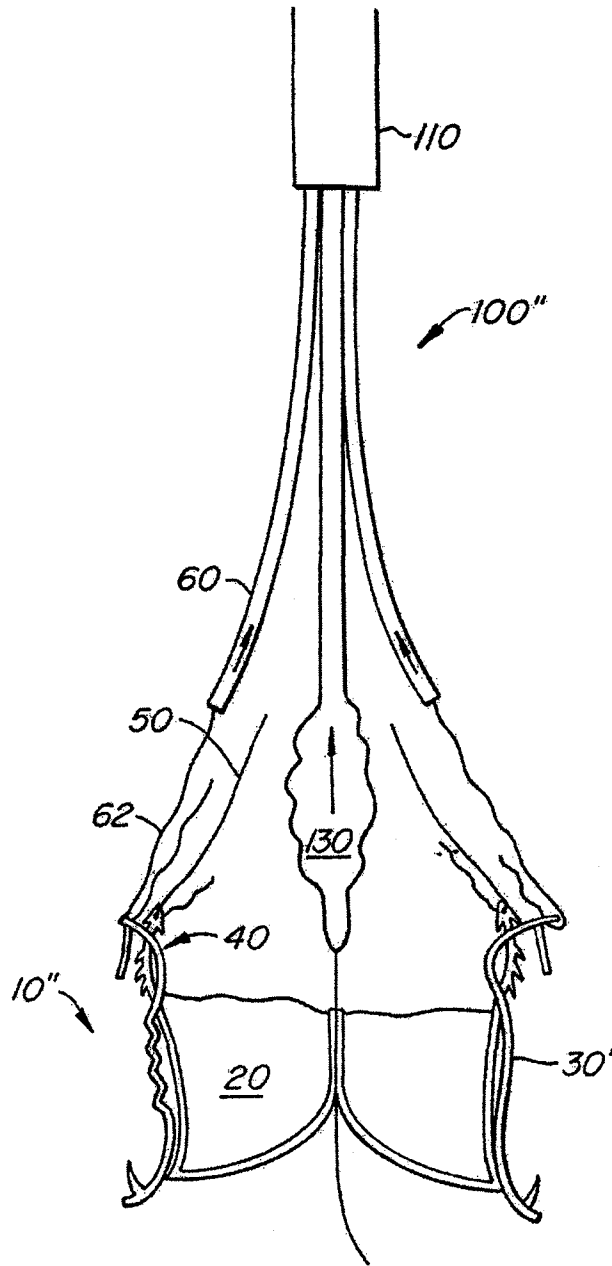

FIG. 8C

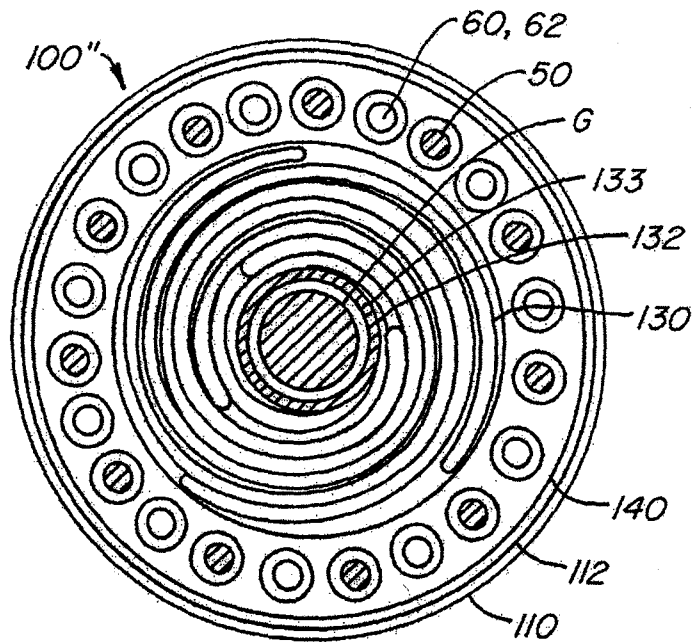

FIG. 10

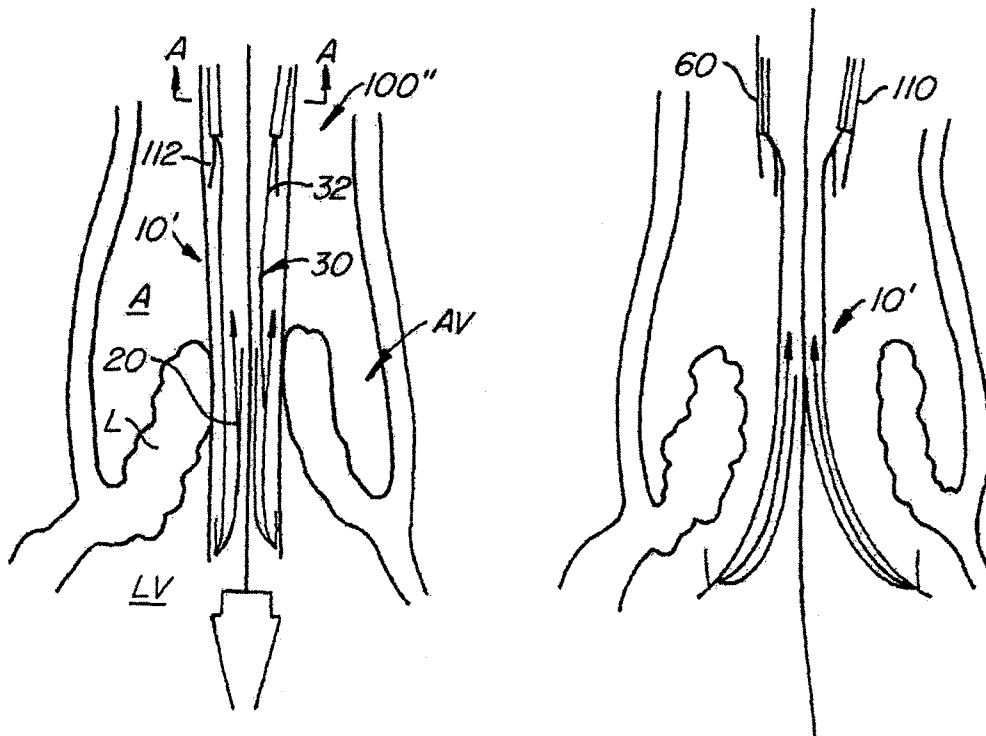

FIG. 9A

FIG. 9B

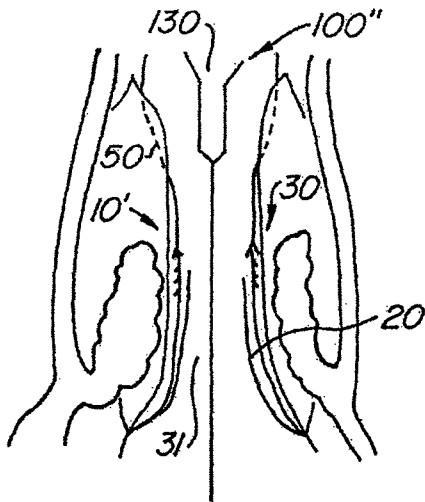

FIG. 9C

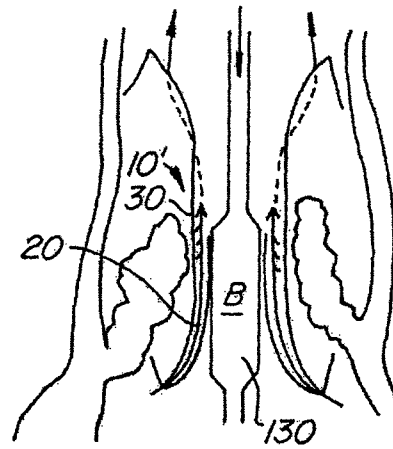

FIG. 9D

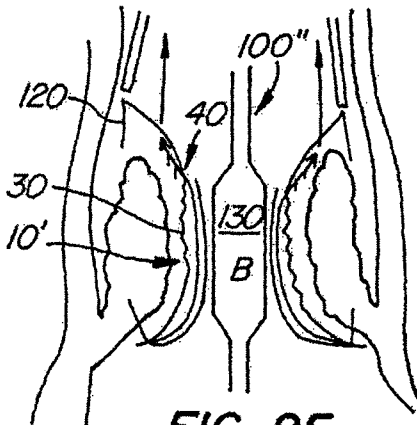

FIG. 9E

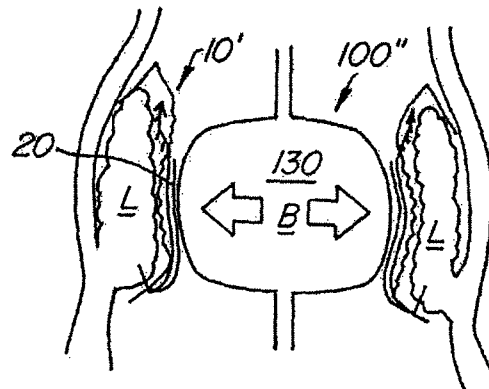

FIG. 9F

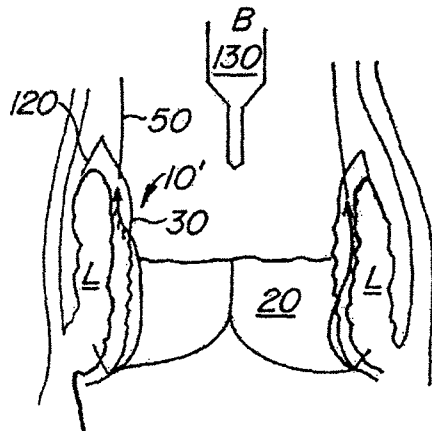

FIG. 9G

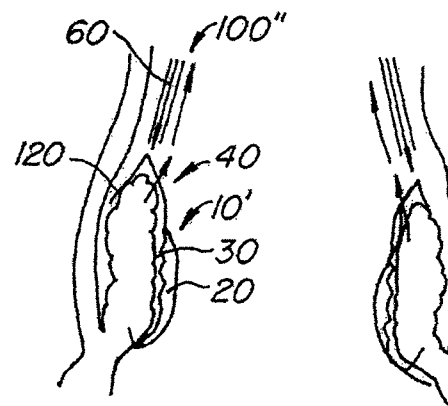

FIG. 9H

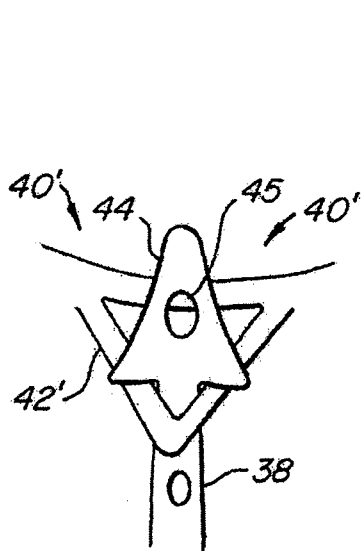

FIG. IIA

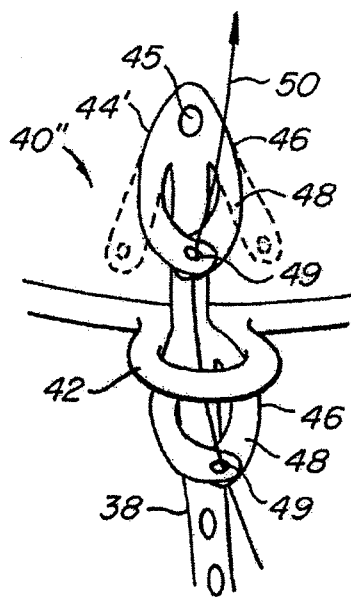

FIG. IIB

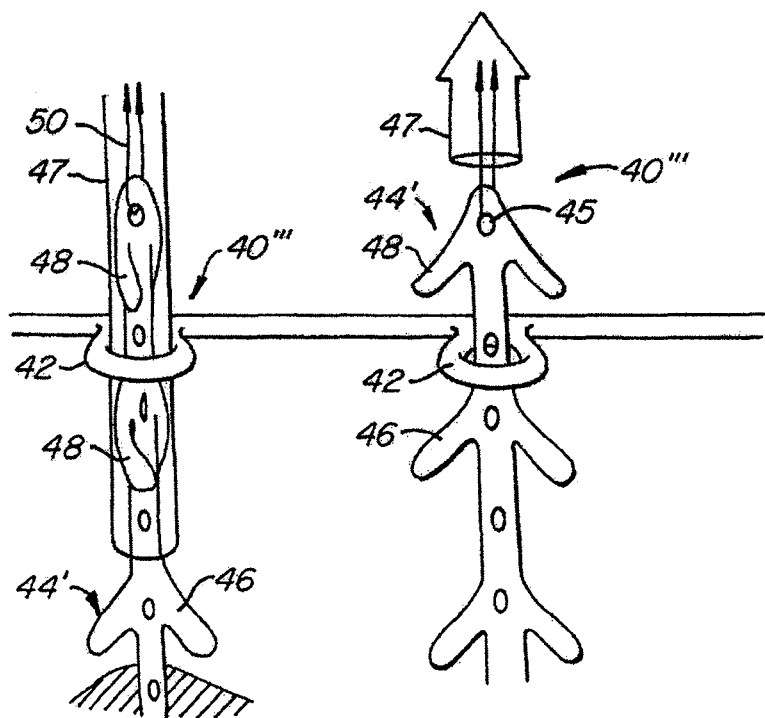

FIG. IIC

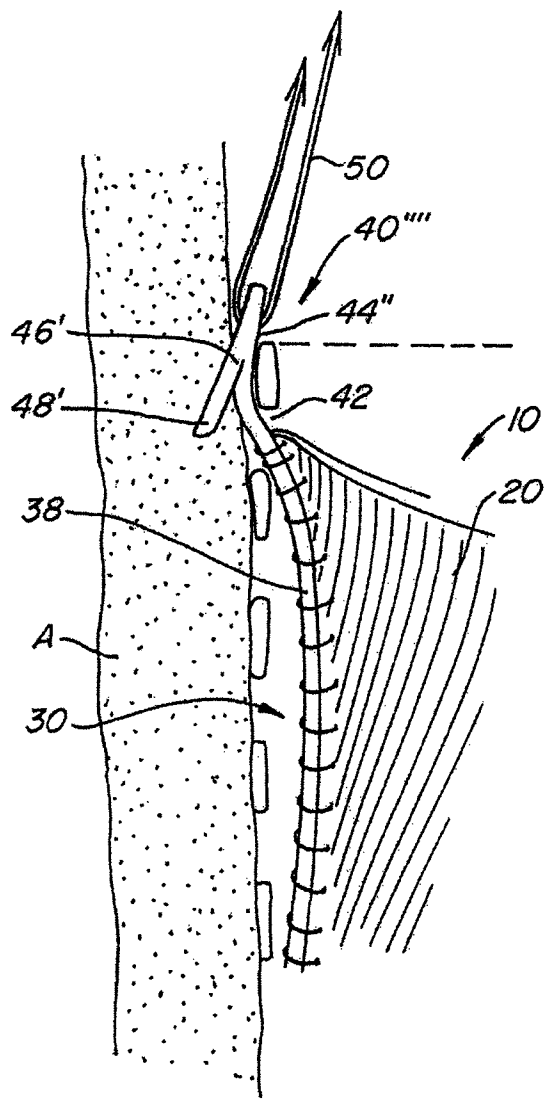

FIG. 12C

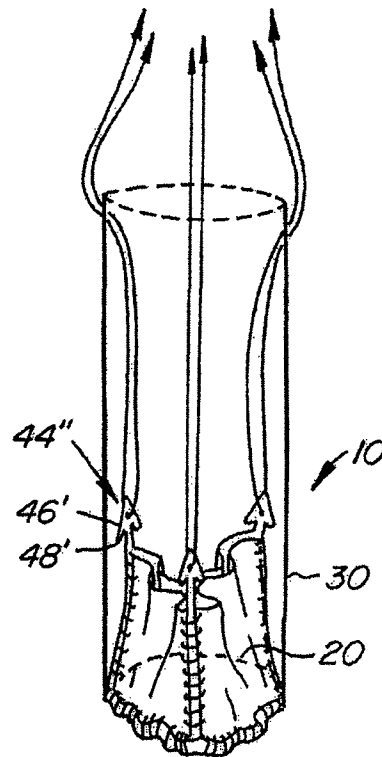

FIG. 12A

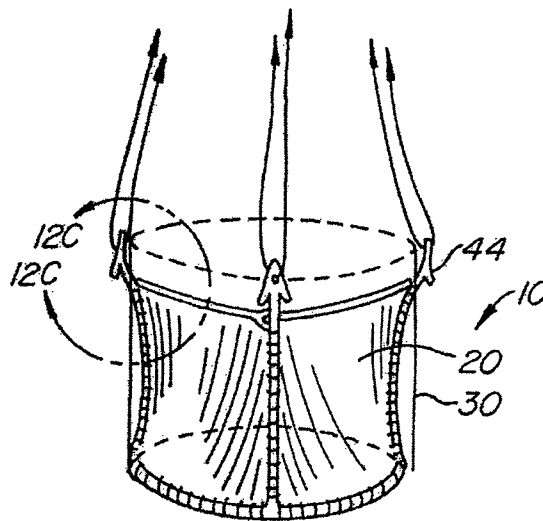

FIG. 12B

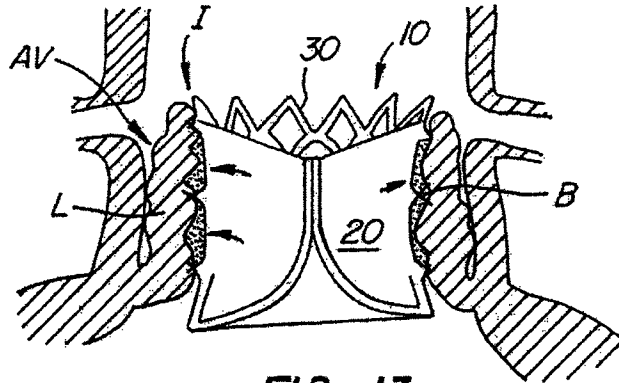

FIG. 13

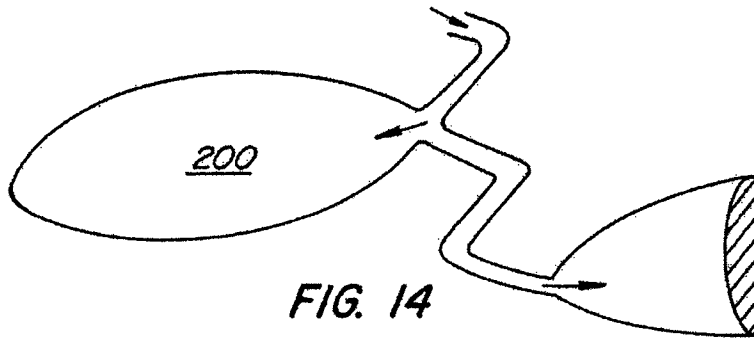

FIG. 14

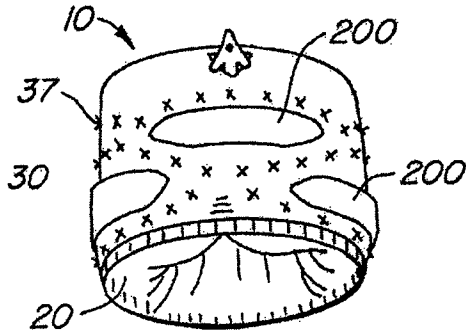

FIG. 15A

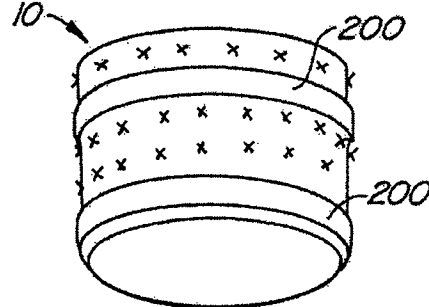

FIG. 15B

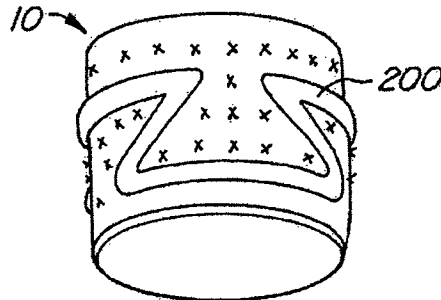

FIG. 15C

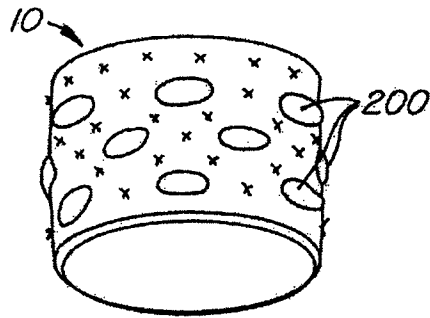

FIG. 15D

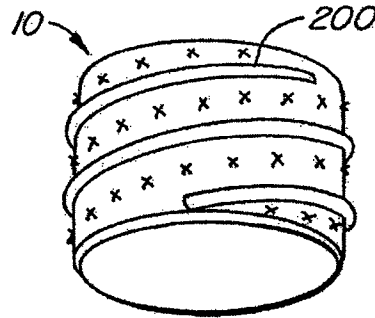

FIG. 15E

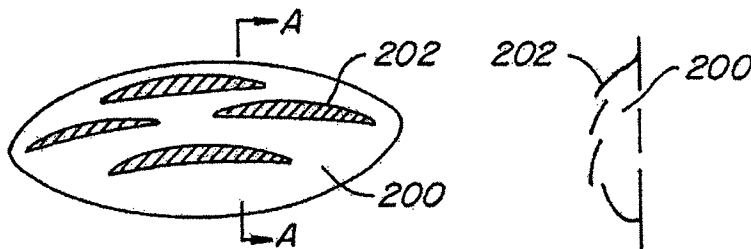

FIG. 16A

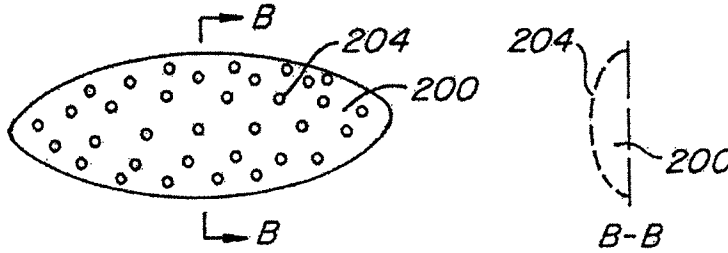

FIG. 16B

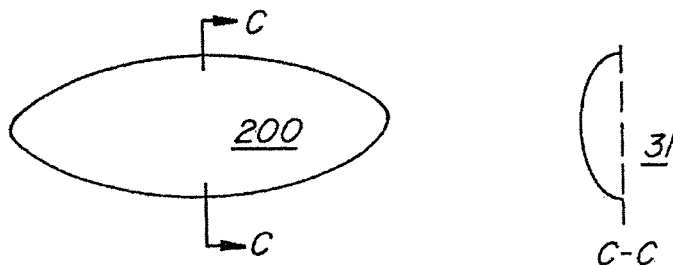
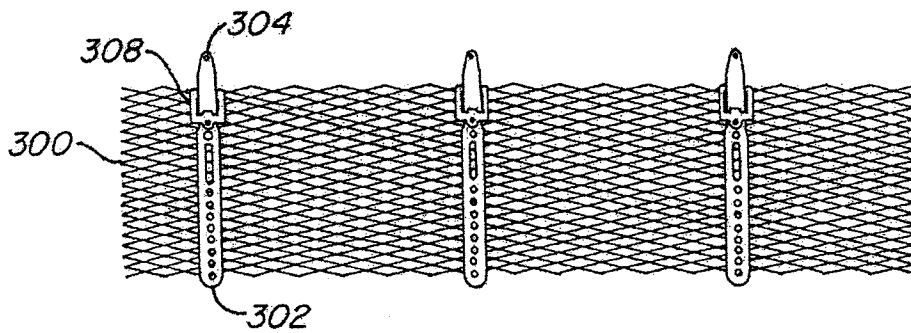
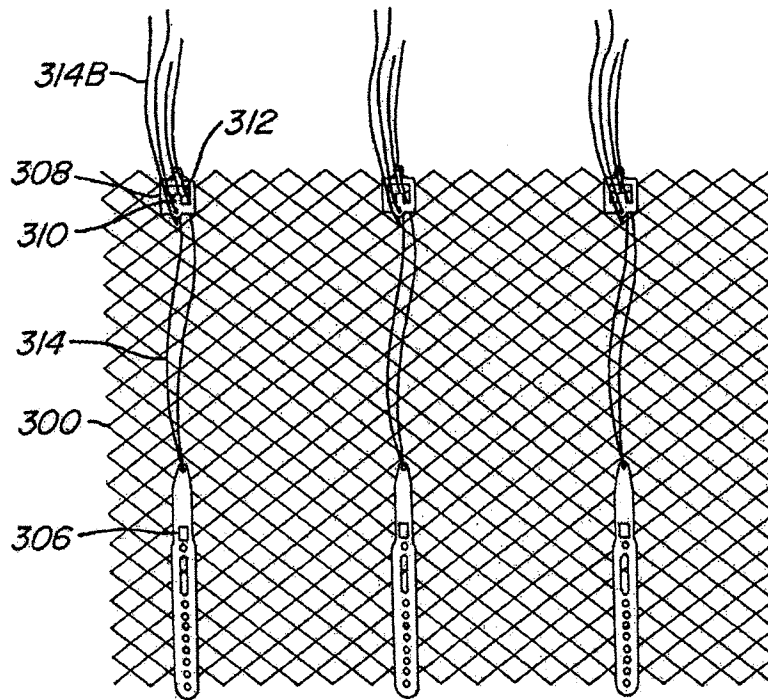

FIG. 16C





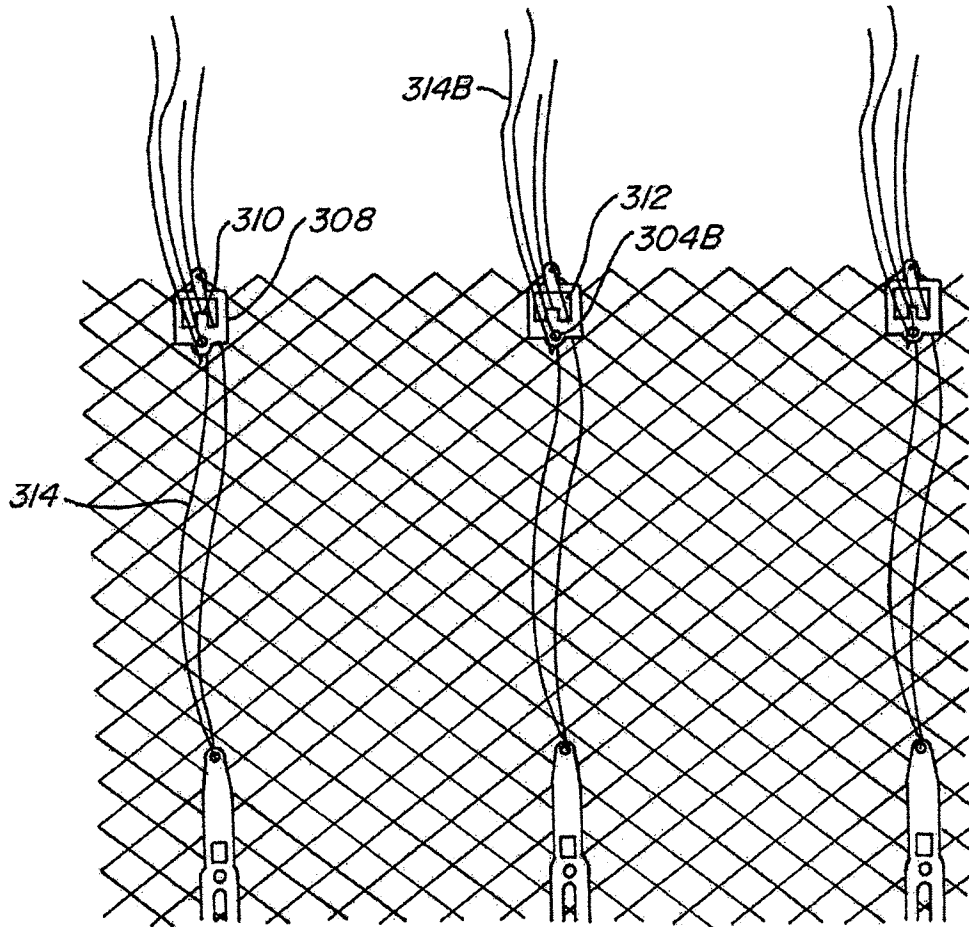

FIG. 17B

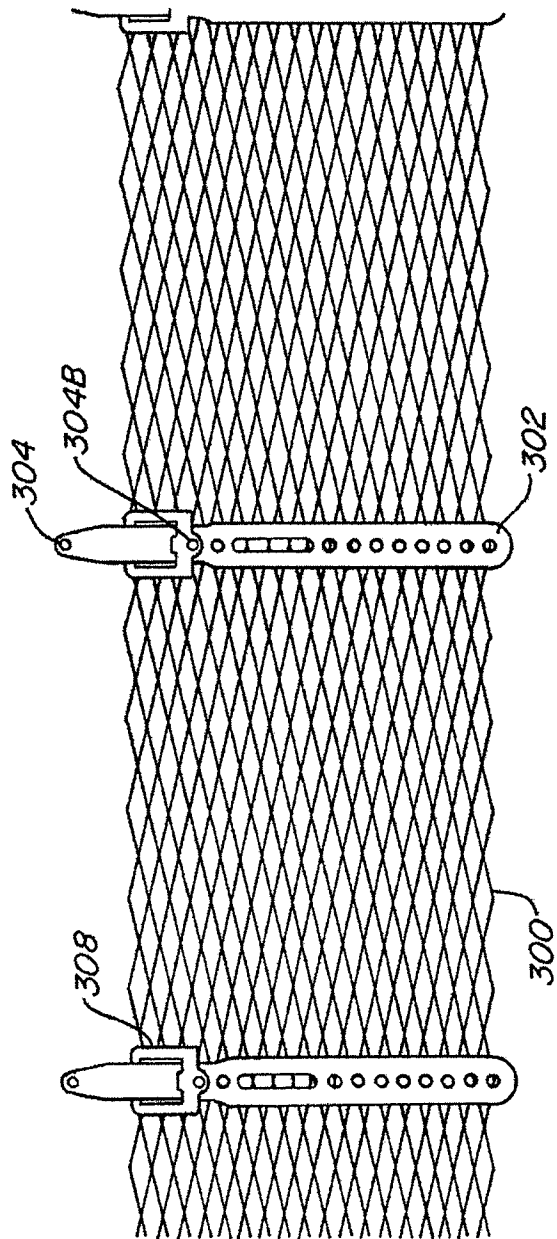

FIG. 18B

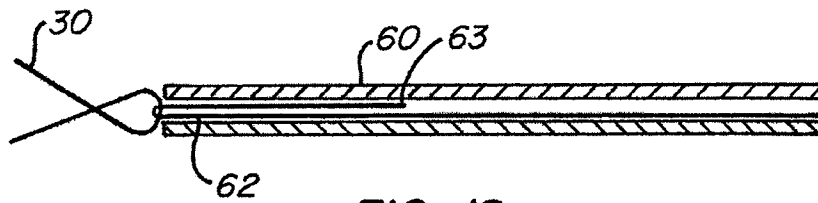

FIG. 19

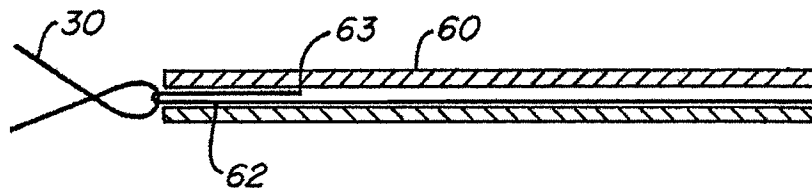

FIG. 20

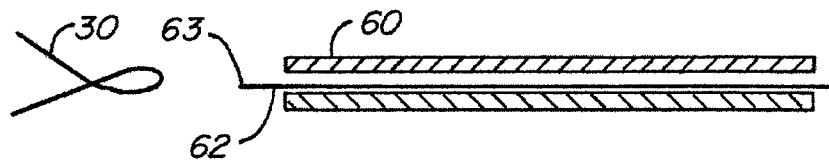

FIG. 21

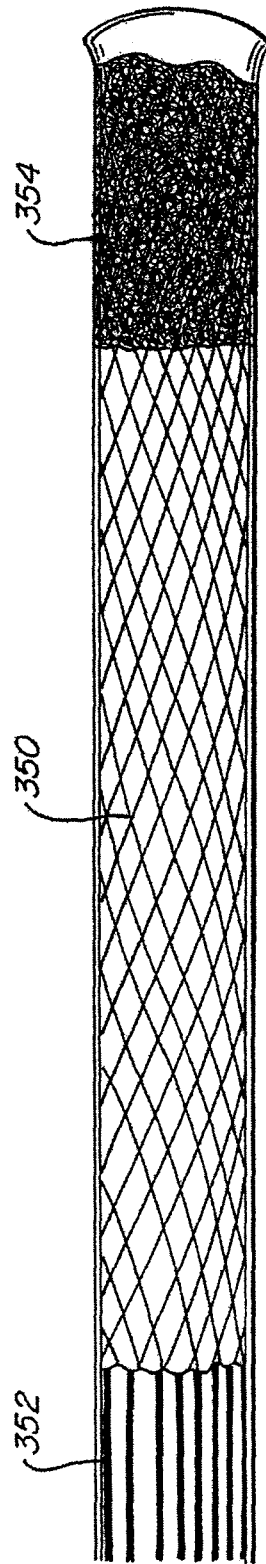

FIG. 22

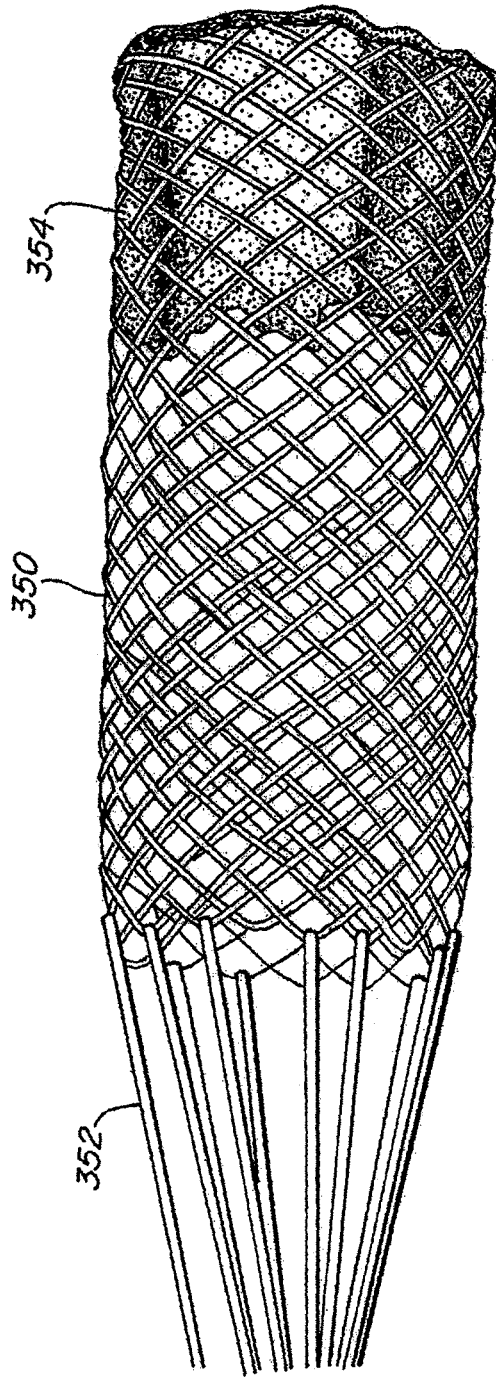

FIG. 23

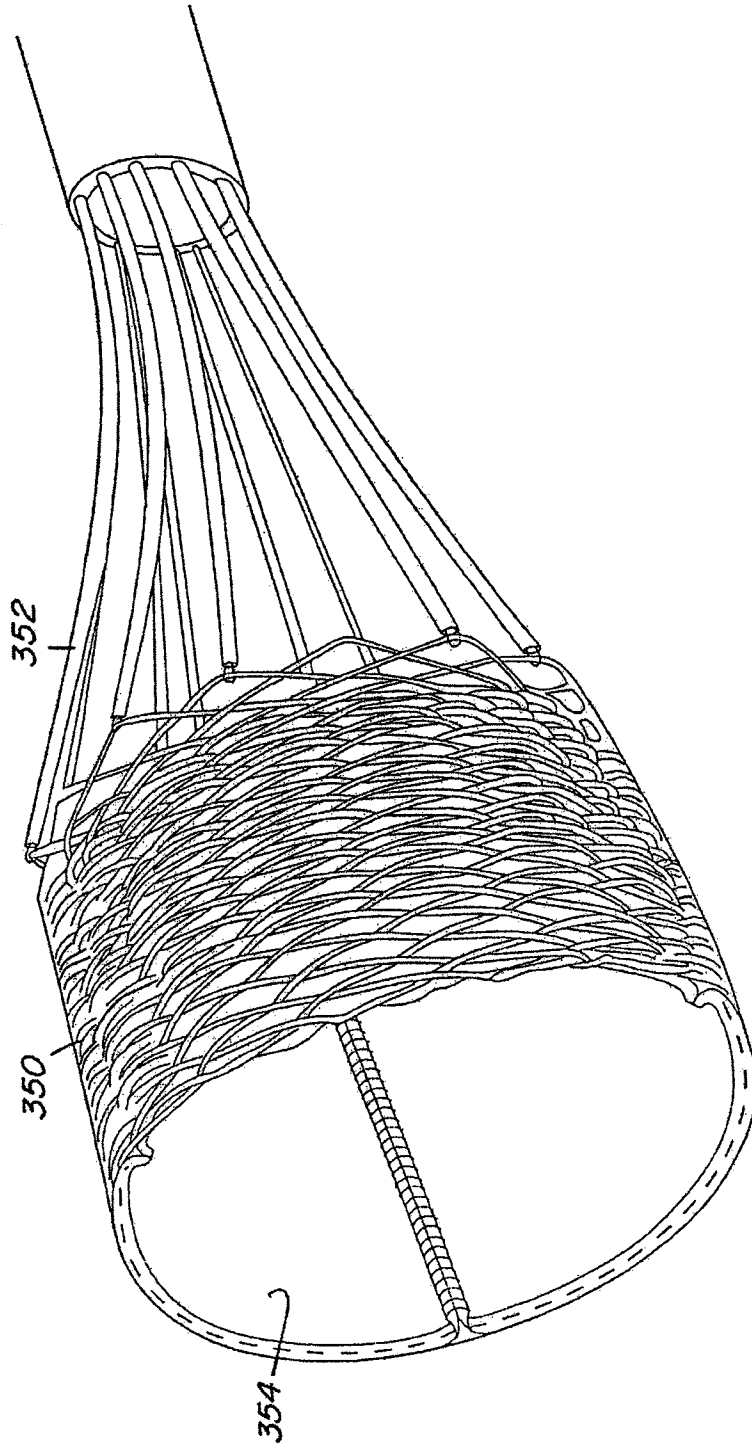

FIG. 24

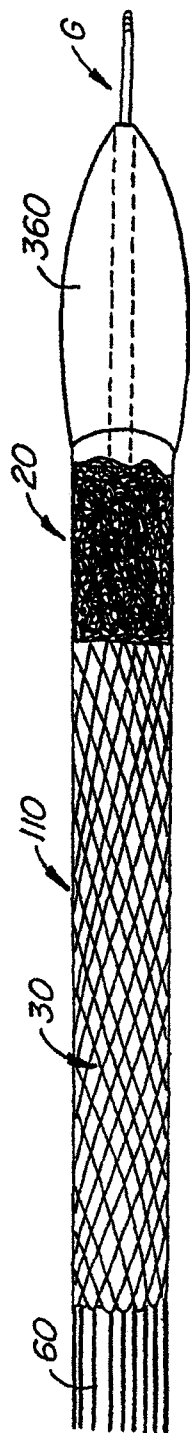

FIG. 25



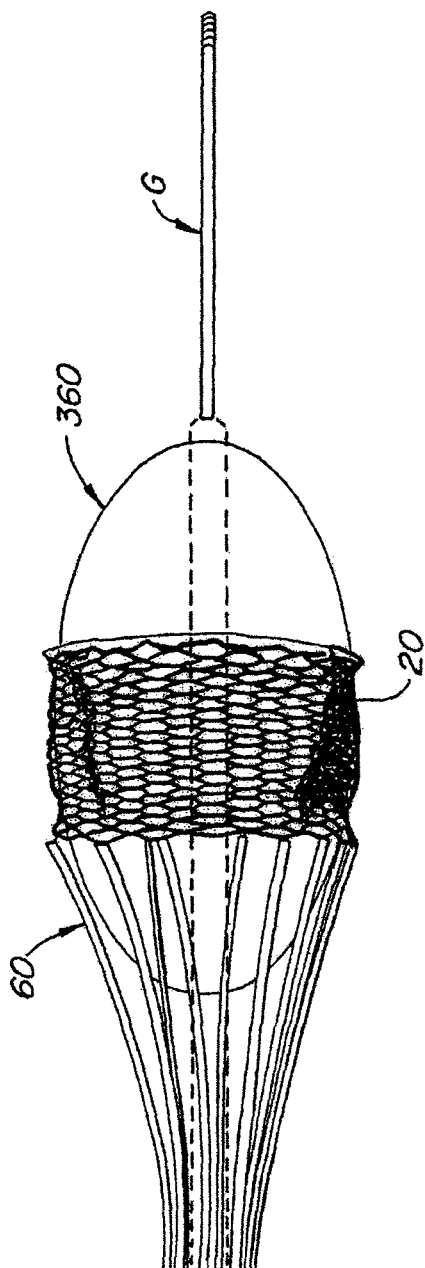

FIG. 26

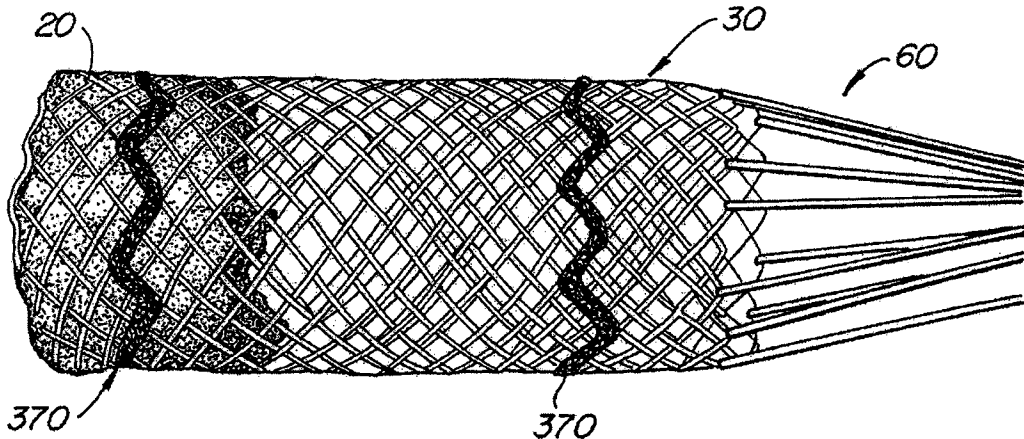

FIG. 27

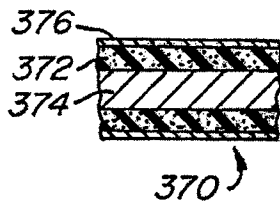

FIG. 28

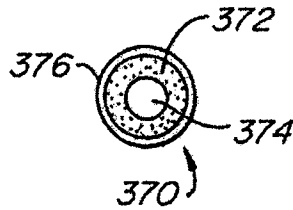

FIG. 29

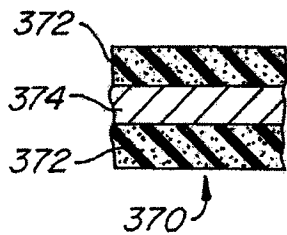

FIG. 30

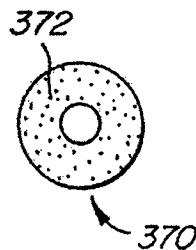

FIG. 31

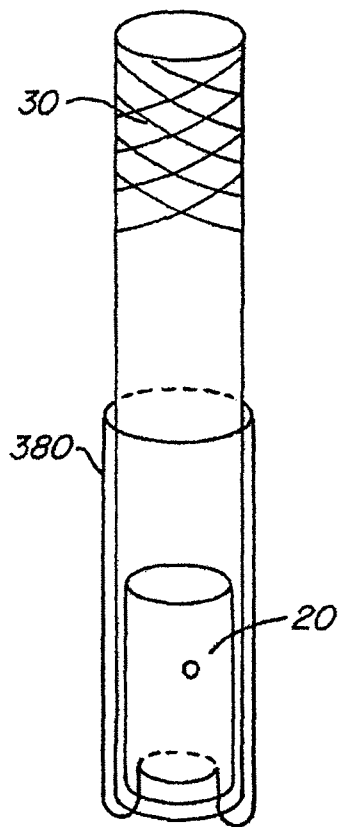

FIG. 32

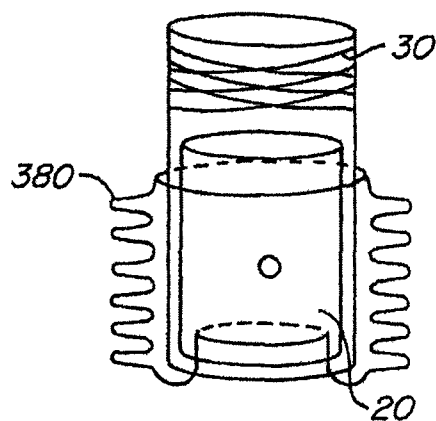

FIG. 33

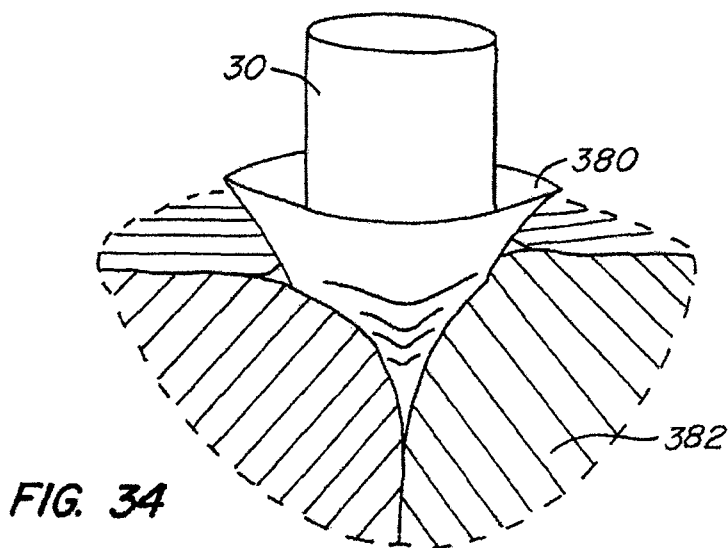

FIG. 34

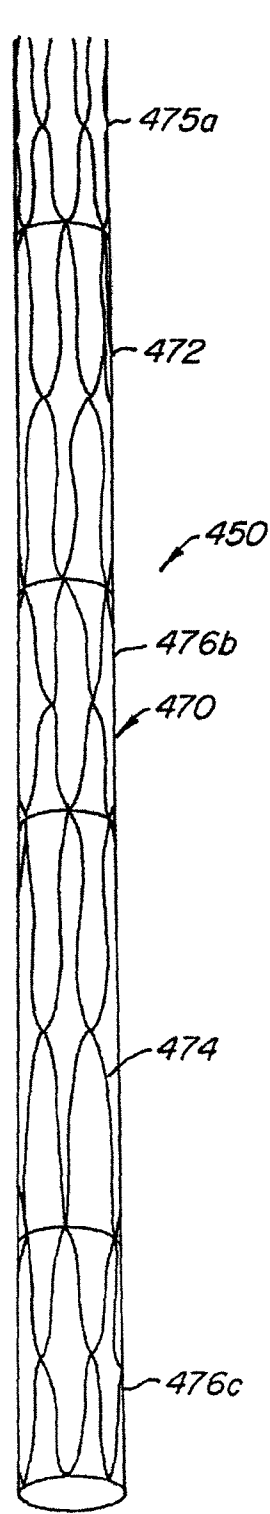

FIG. 35A

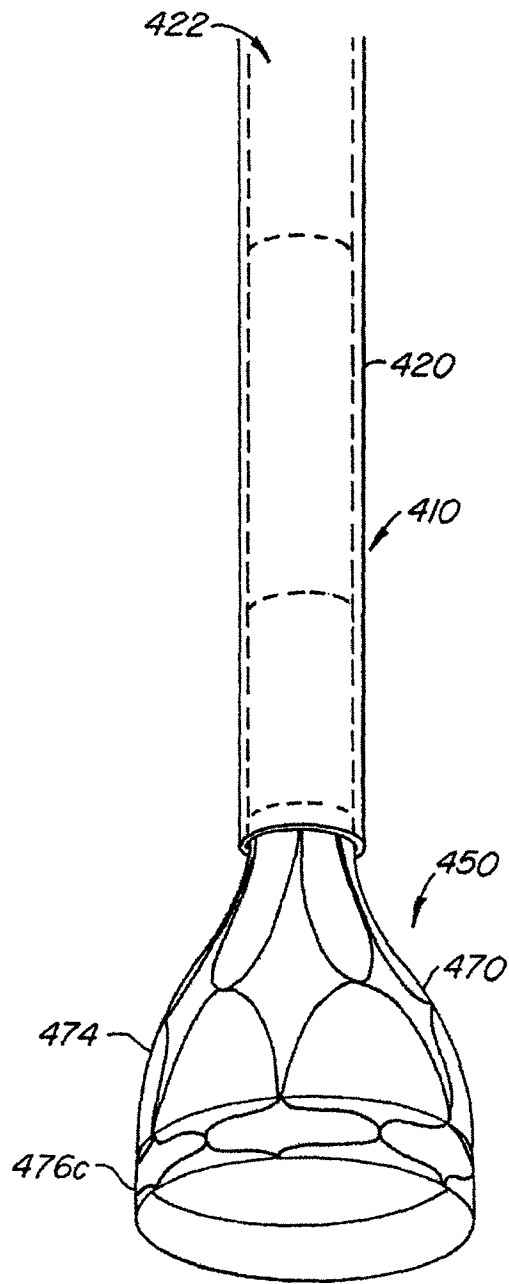

FIG. 35B

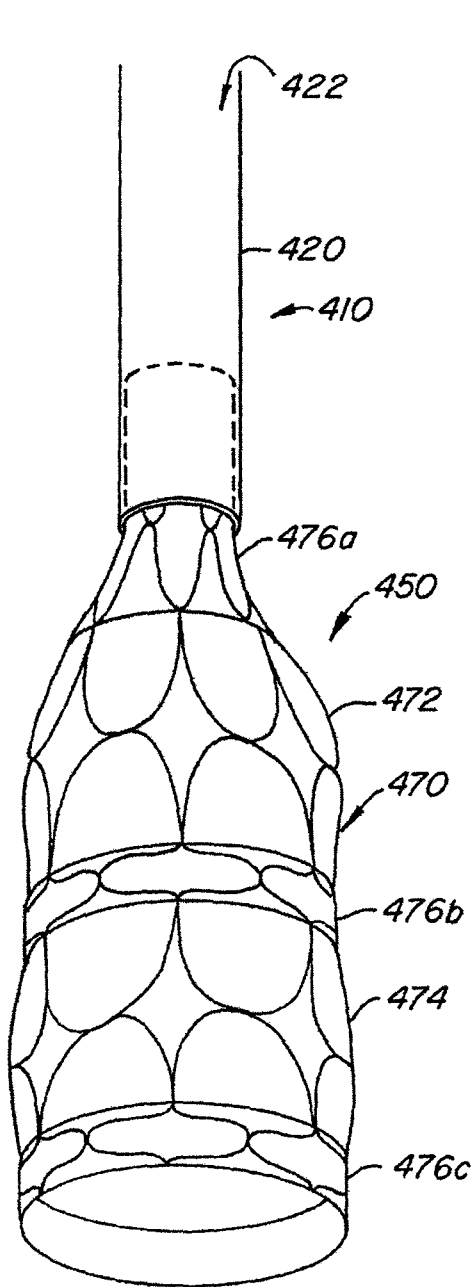

FIG. 35C

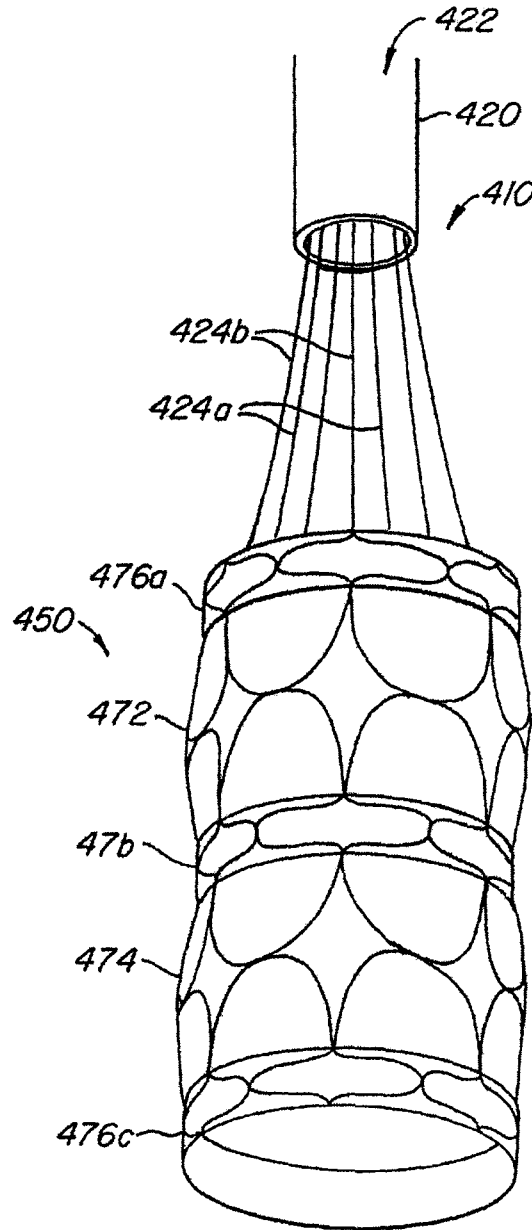

FIG. 35D

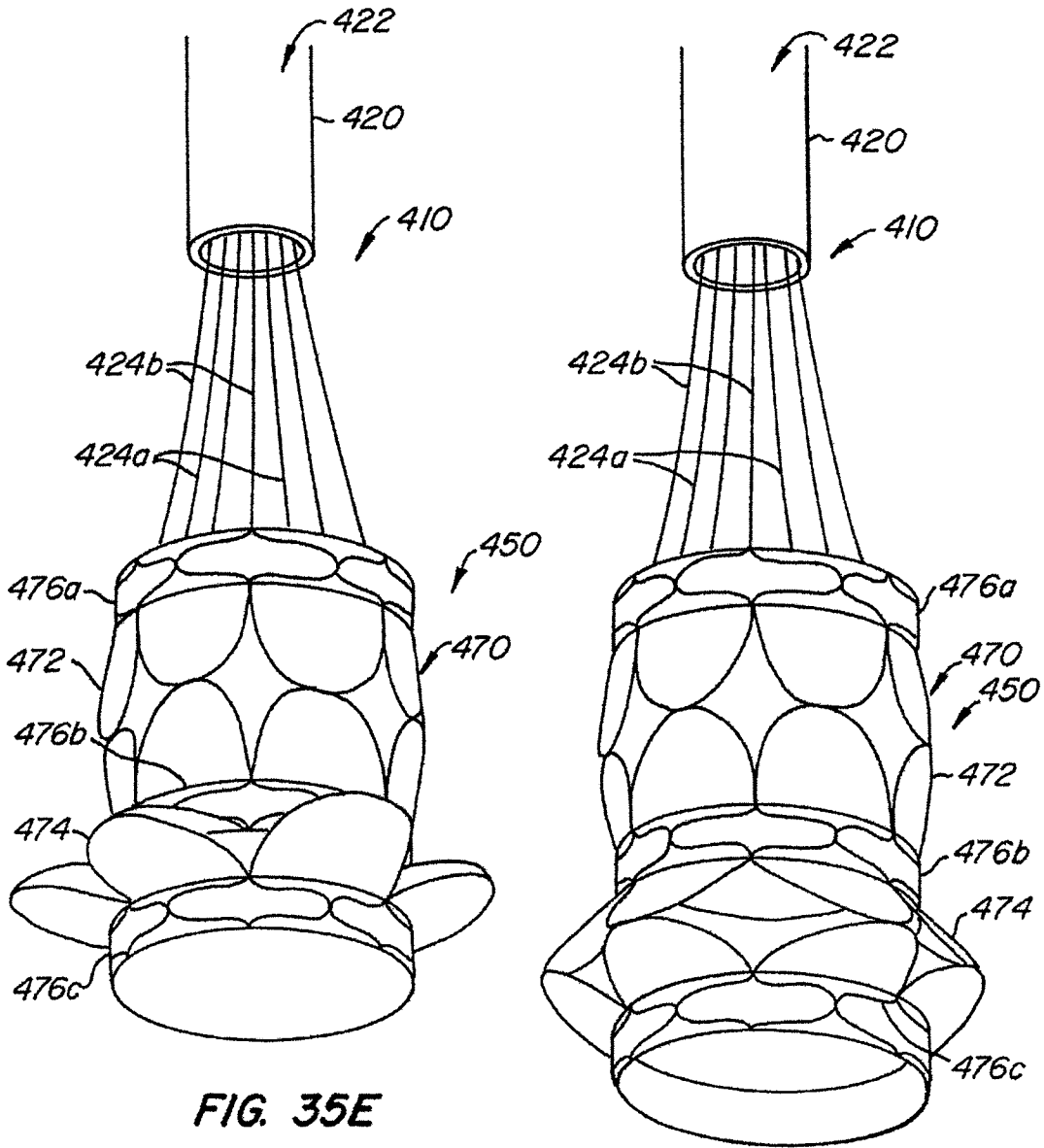

FIG. 35E

FIG. 35F

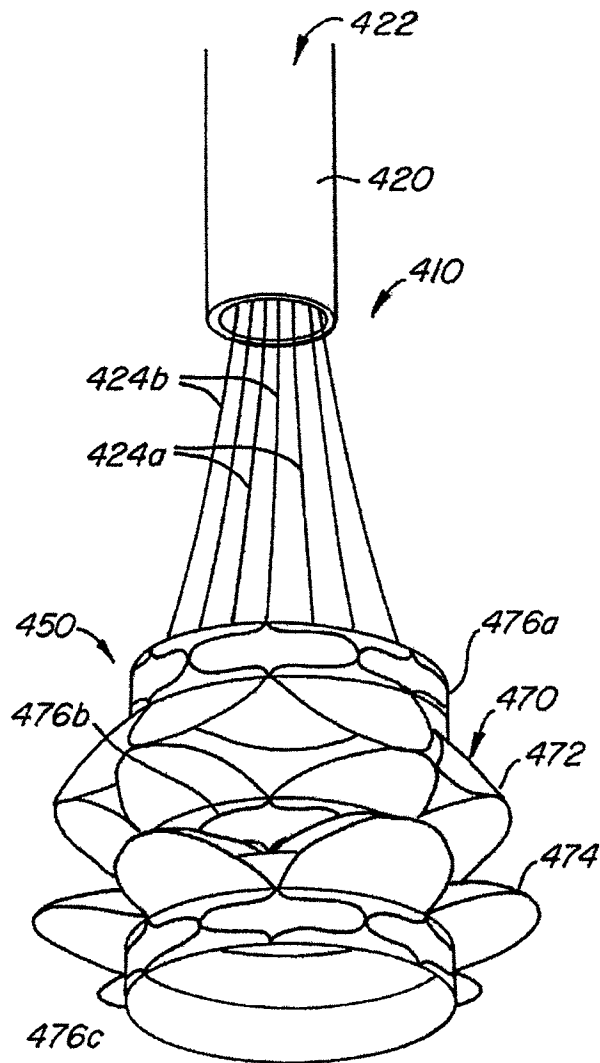

FIG. 35G

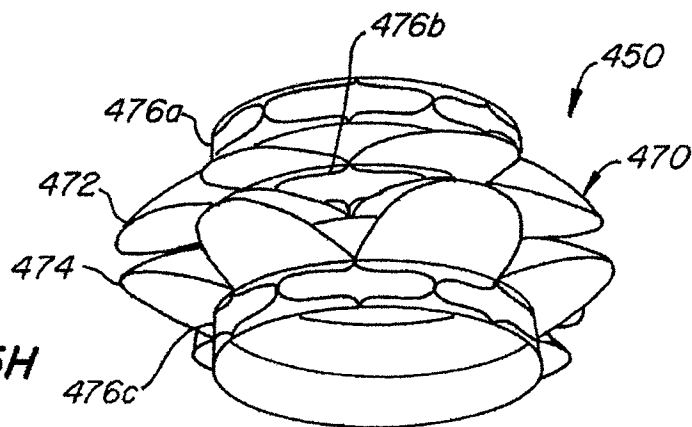

FIG. 35H

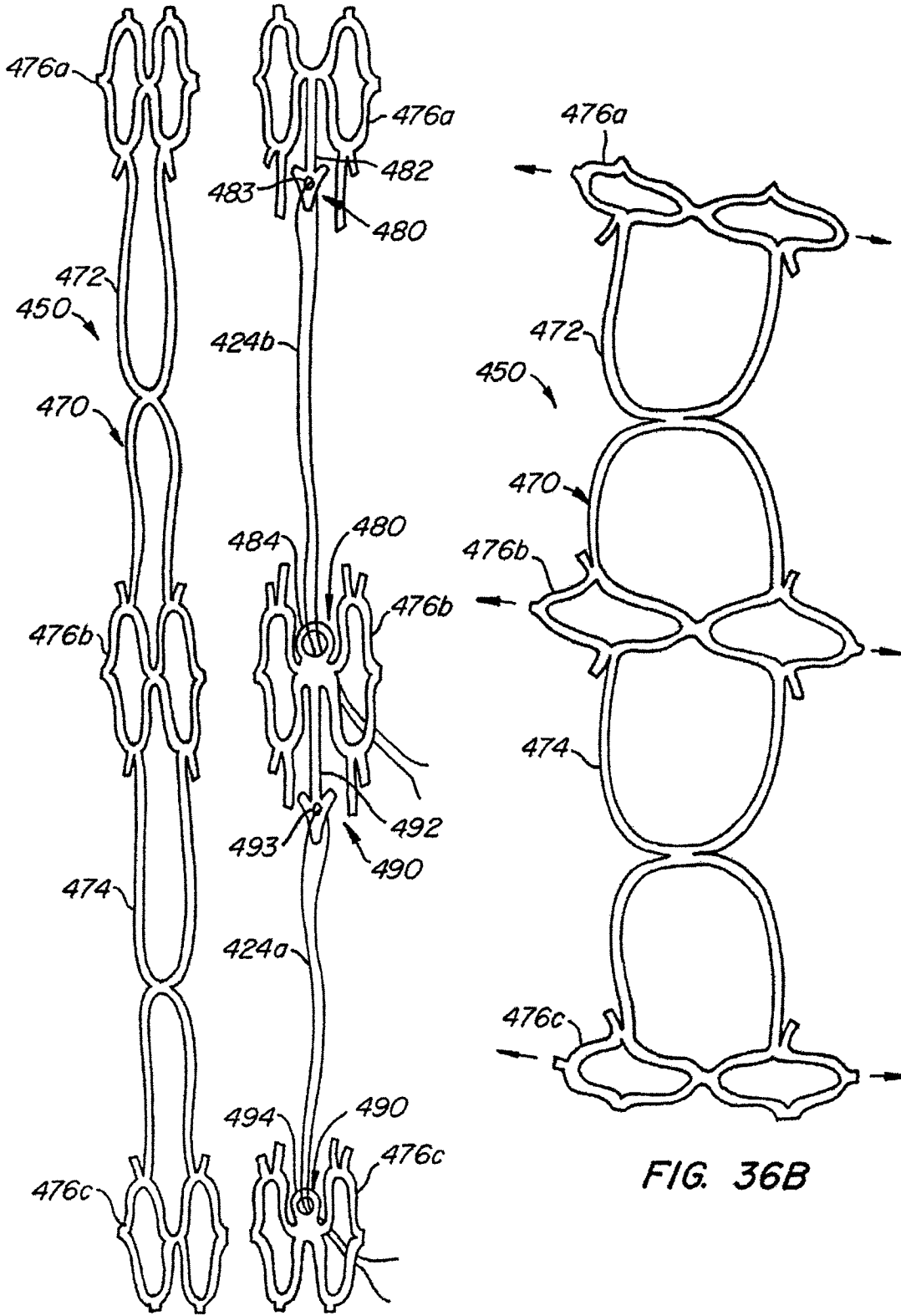

FIG. 36A

FIG. 36B



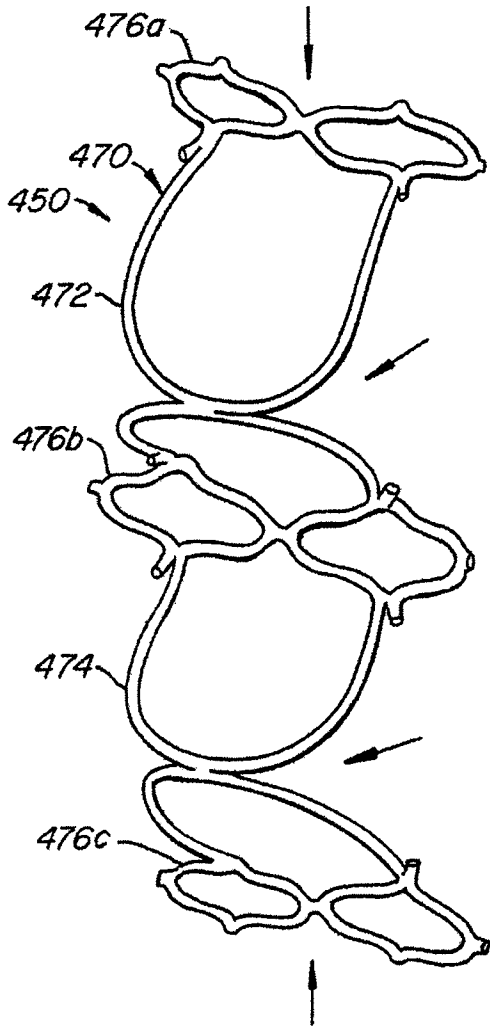

FIG. 36C

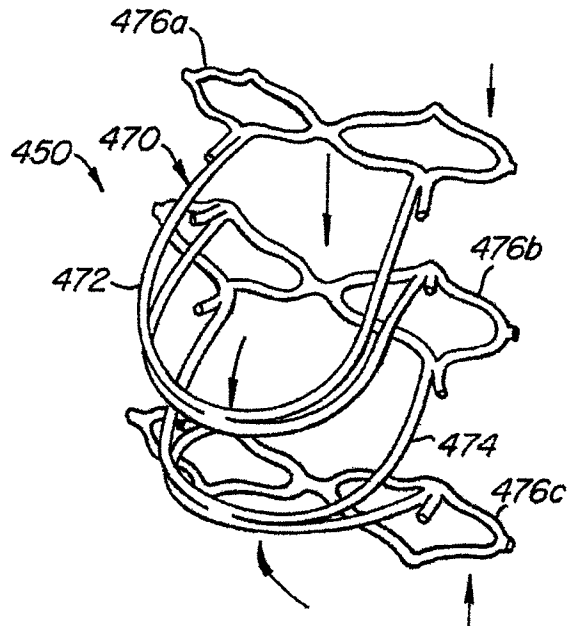

FIG. 36D

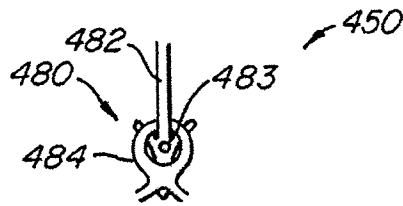

FIG. 36E

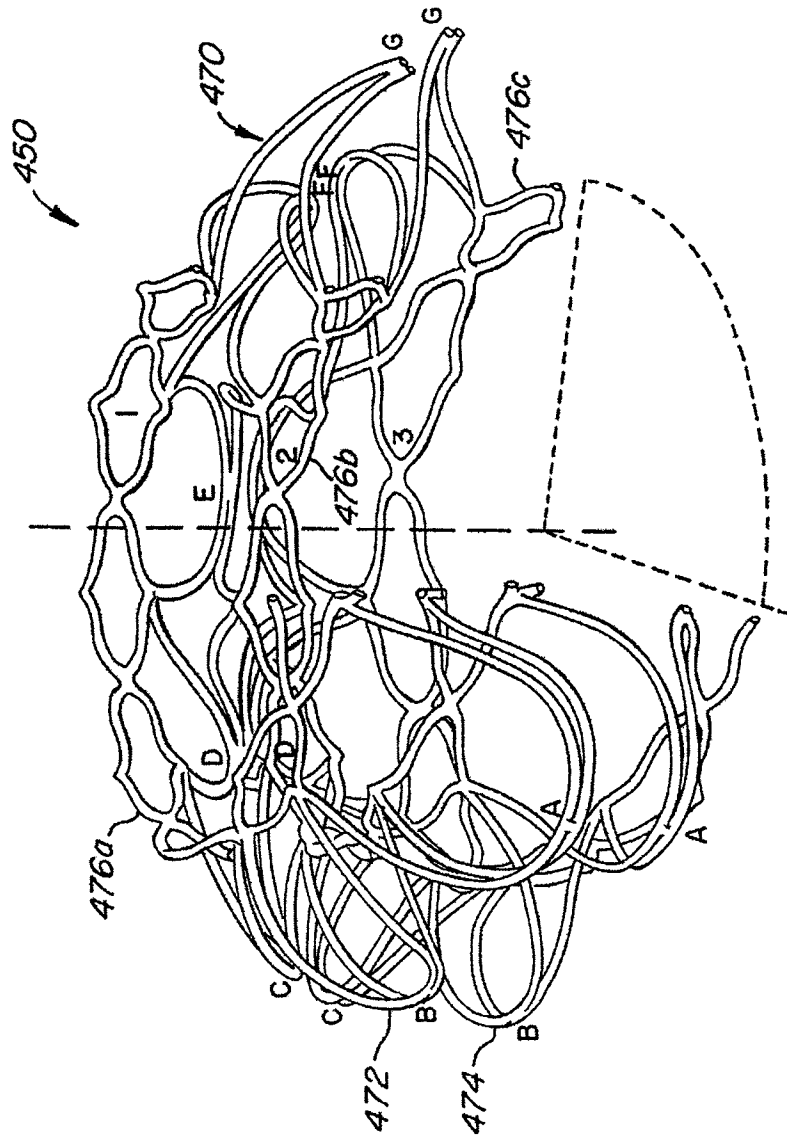

FIG. 37A

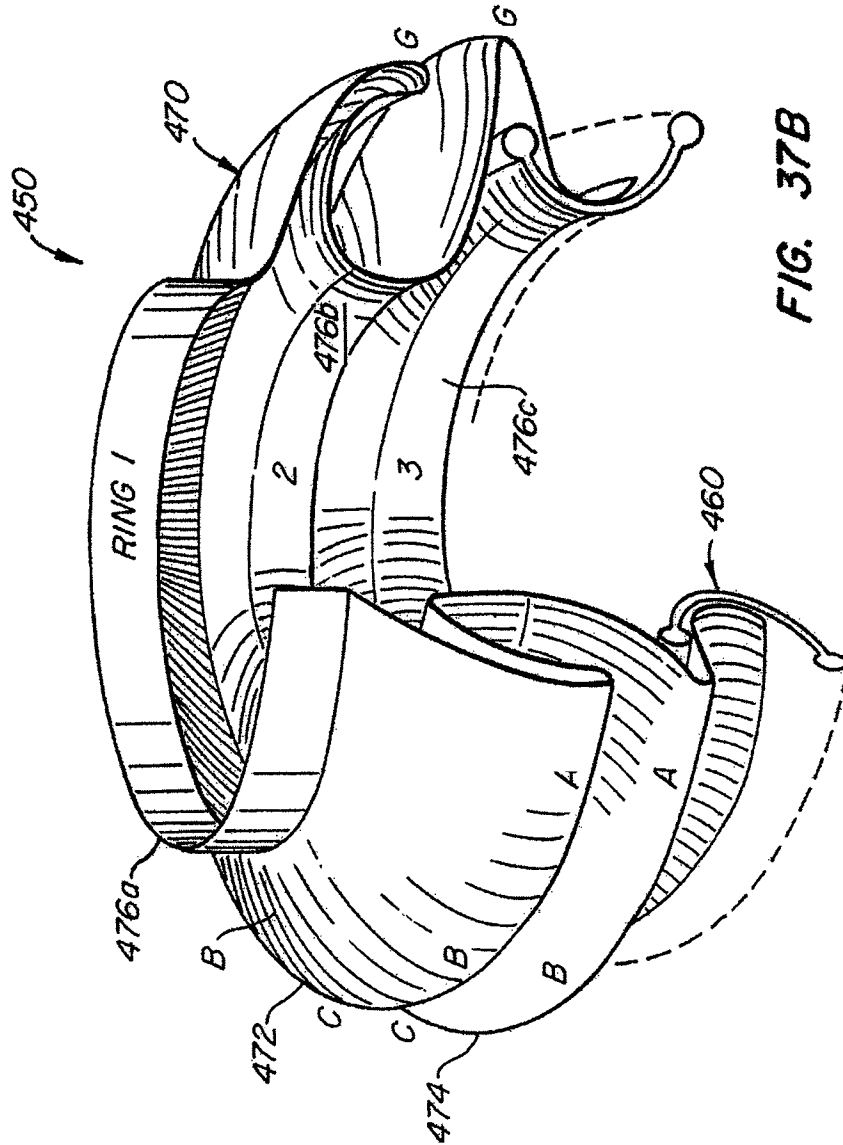

FIG. 37B

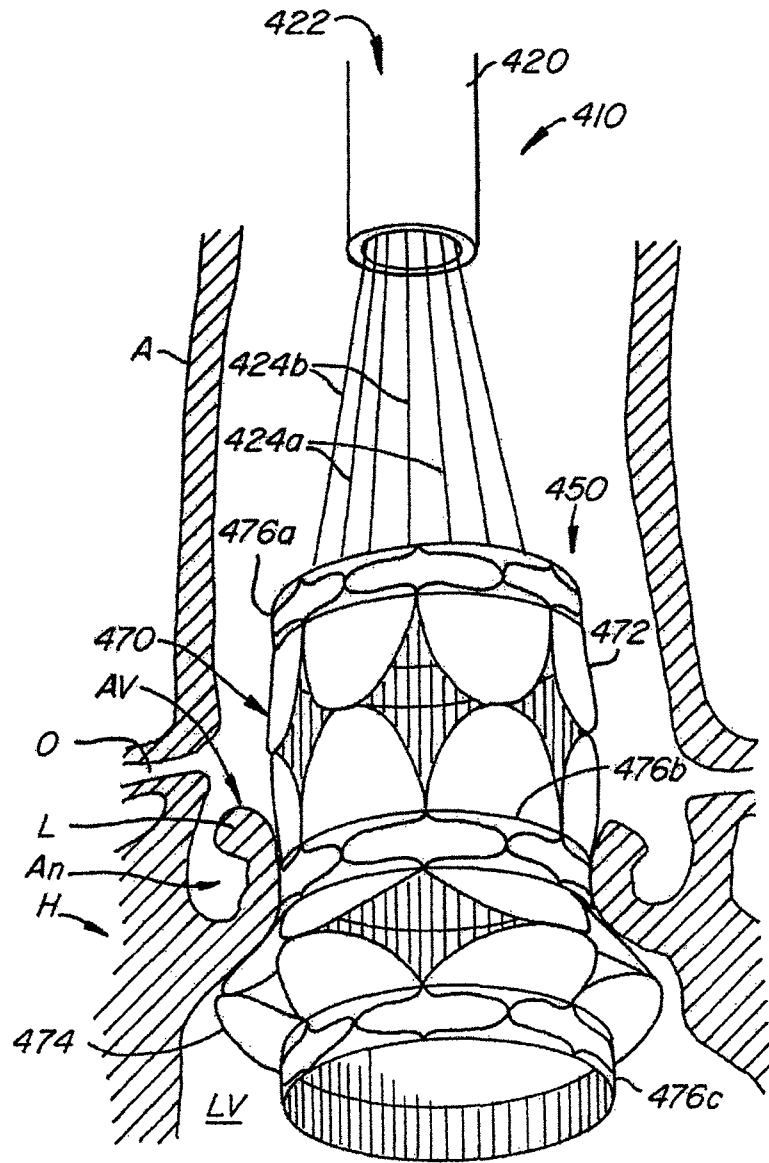

FIG. 38A

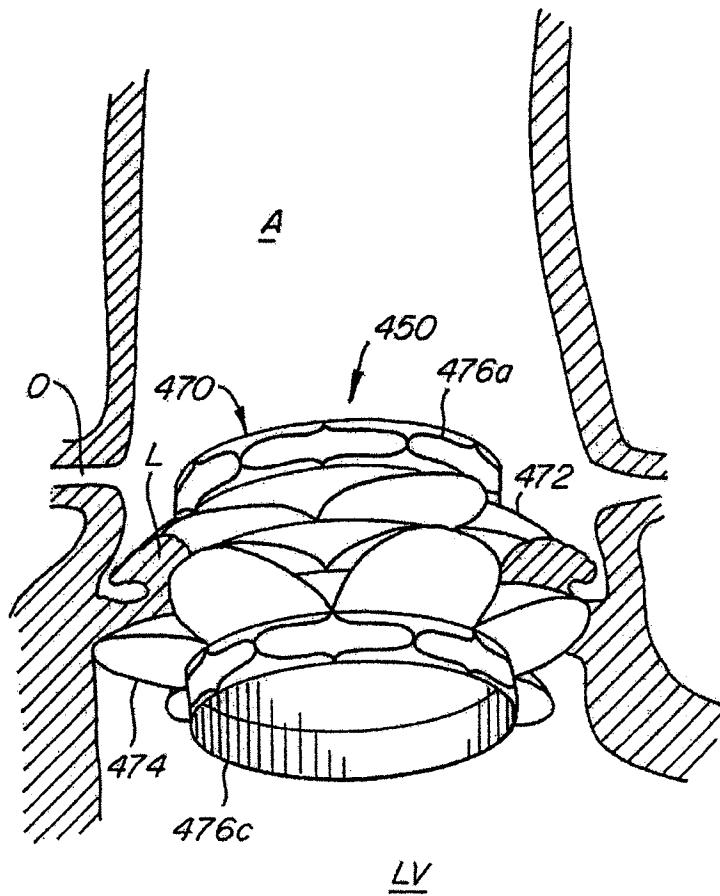

FIG. 38B

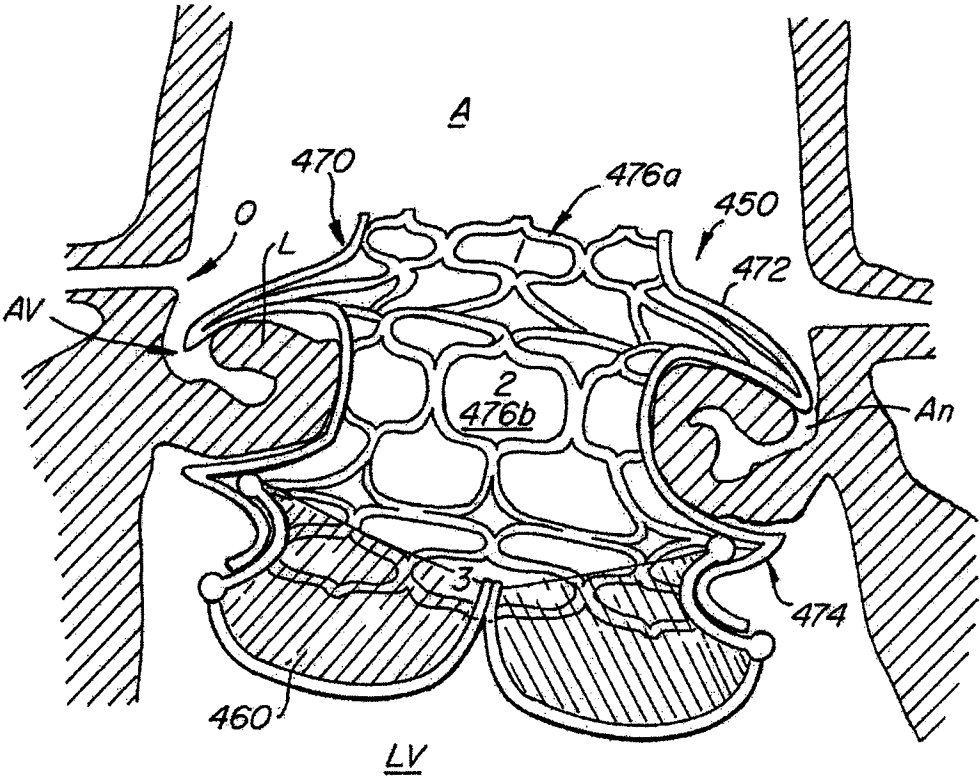
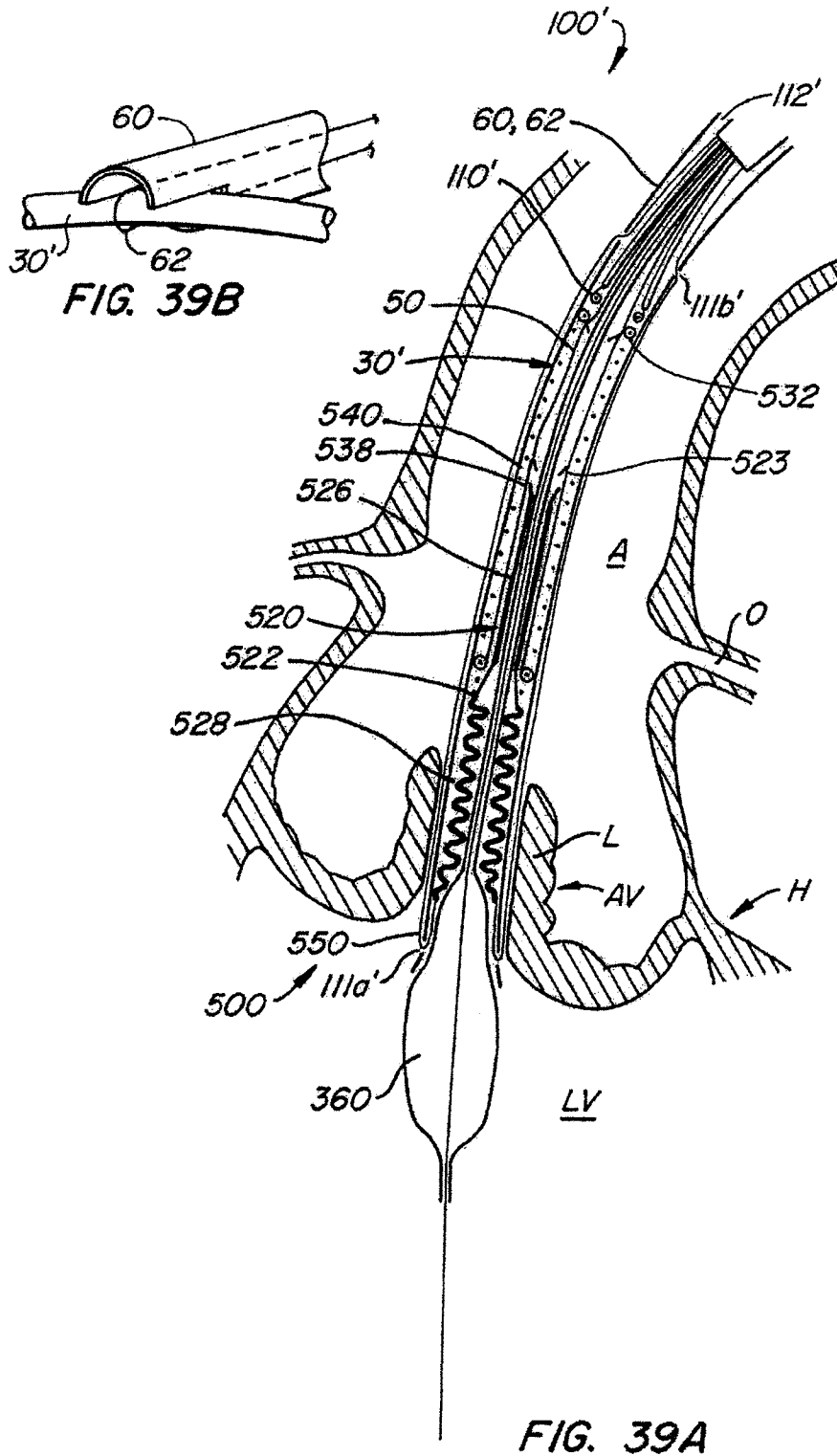
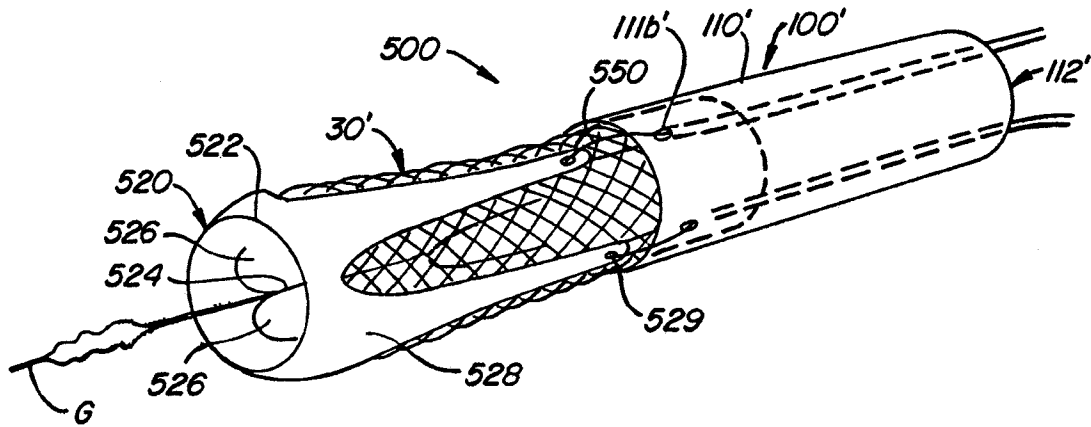

FIG. 38C





**FIG. 39C**



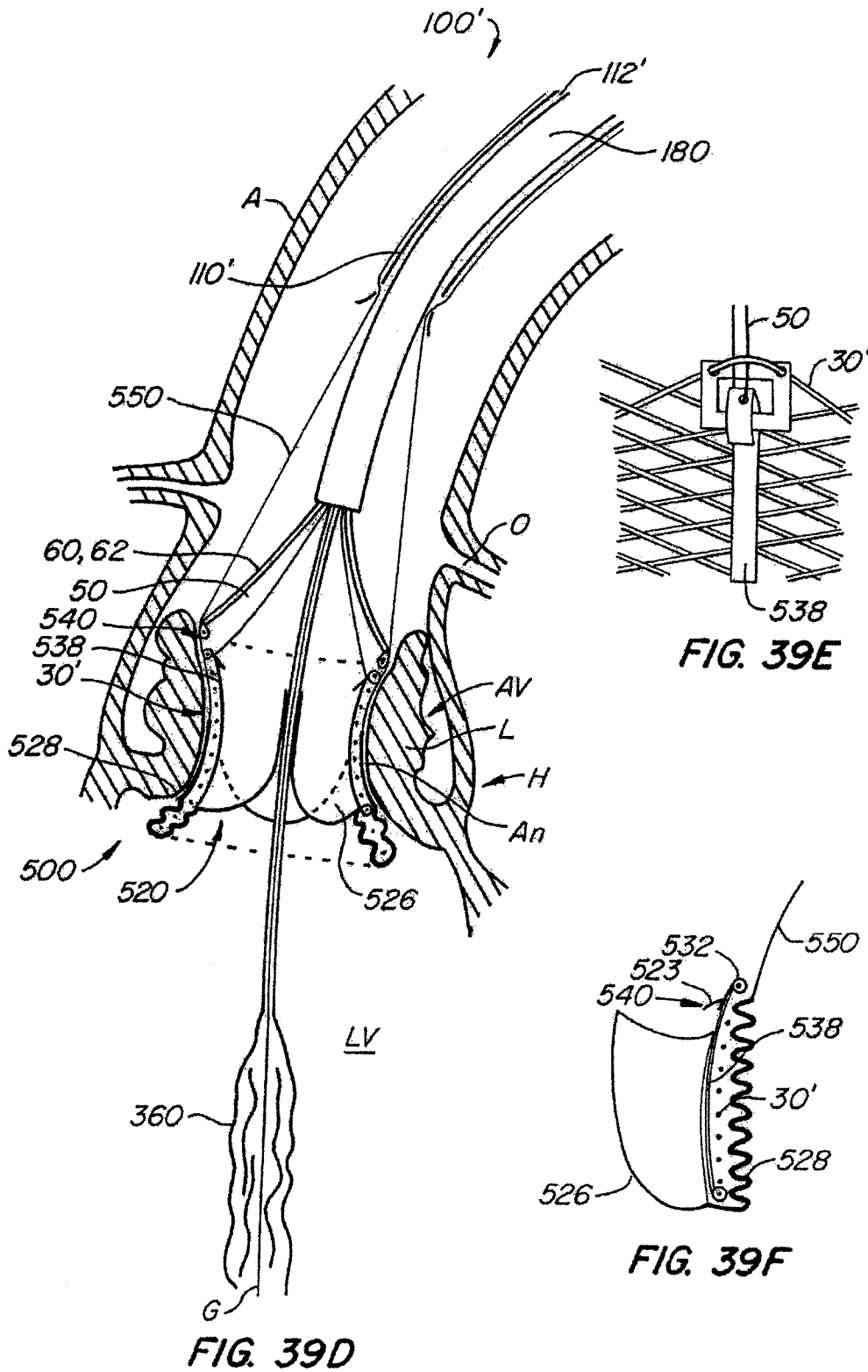

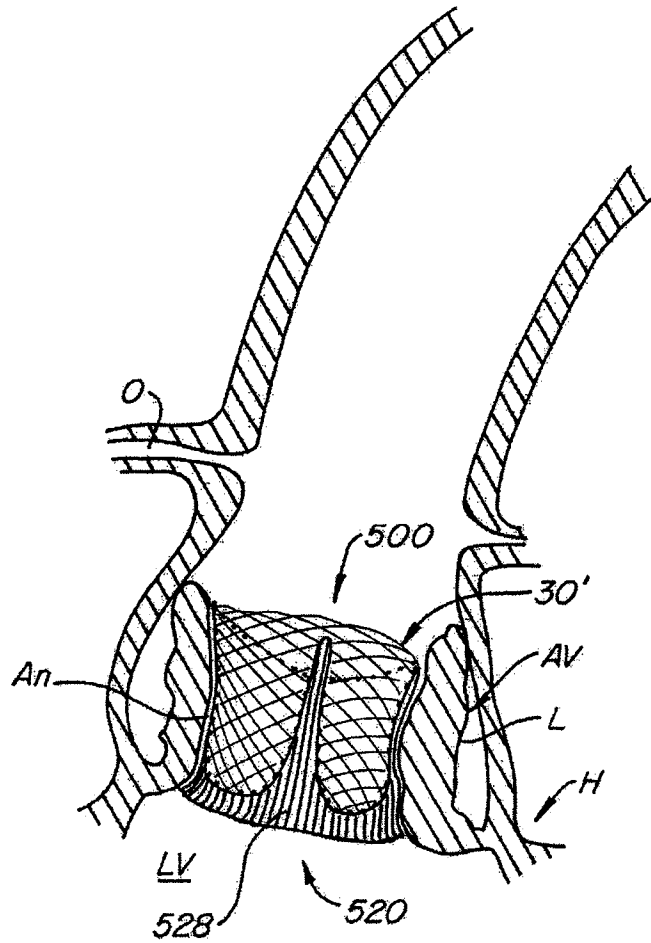

FIG. 396

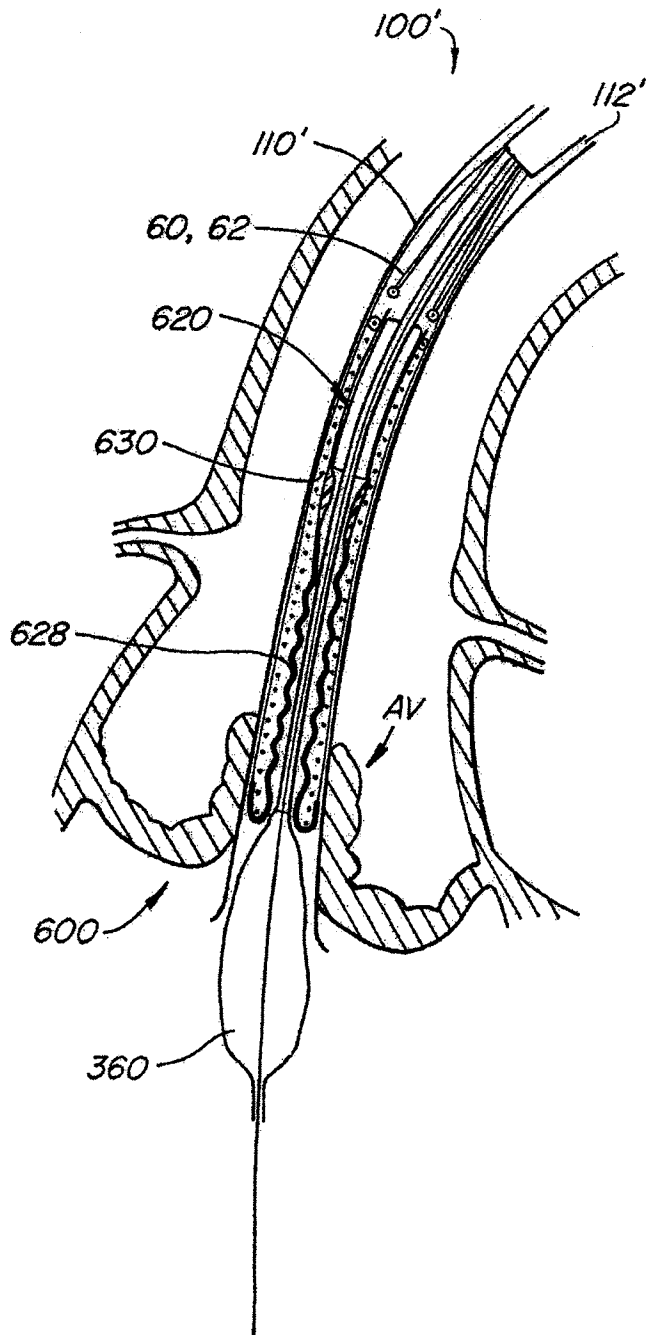
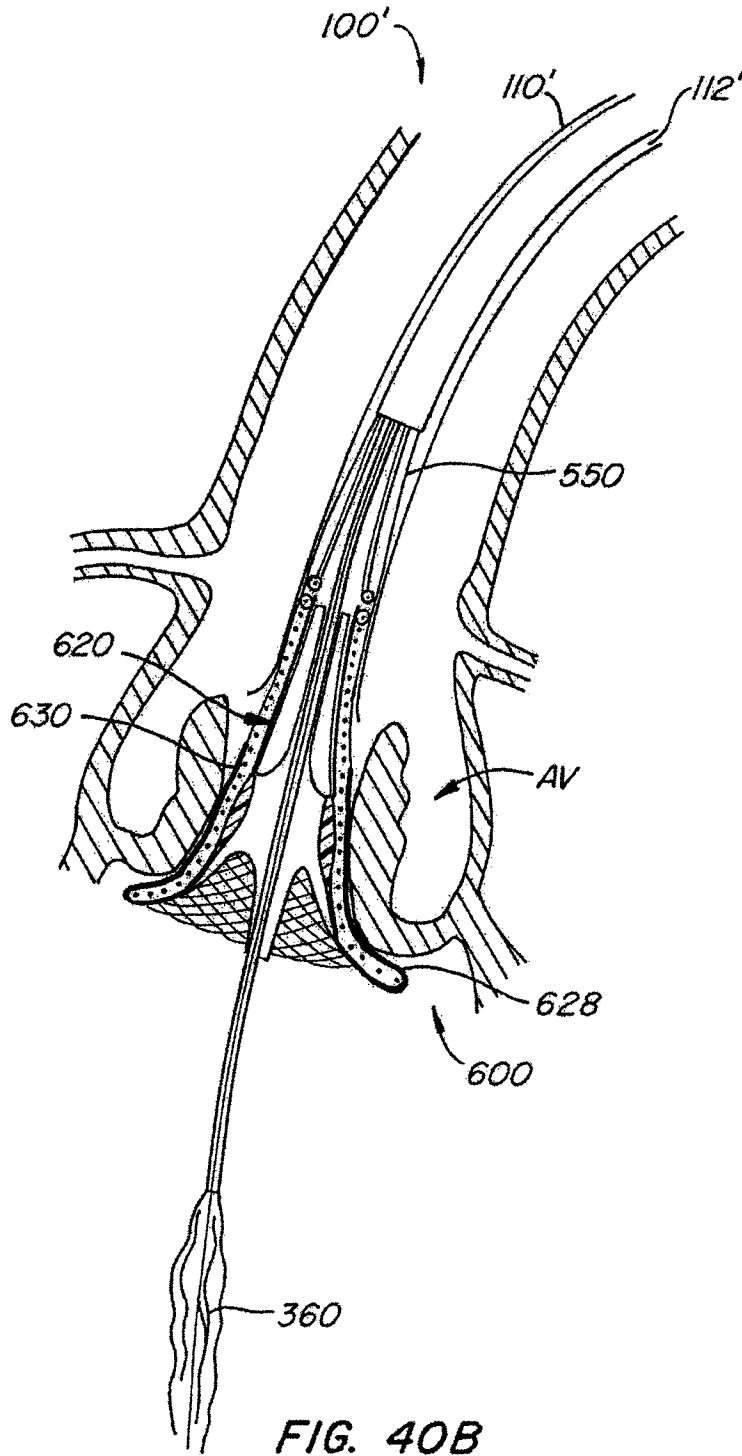

FIG. 40A



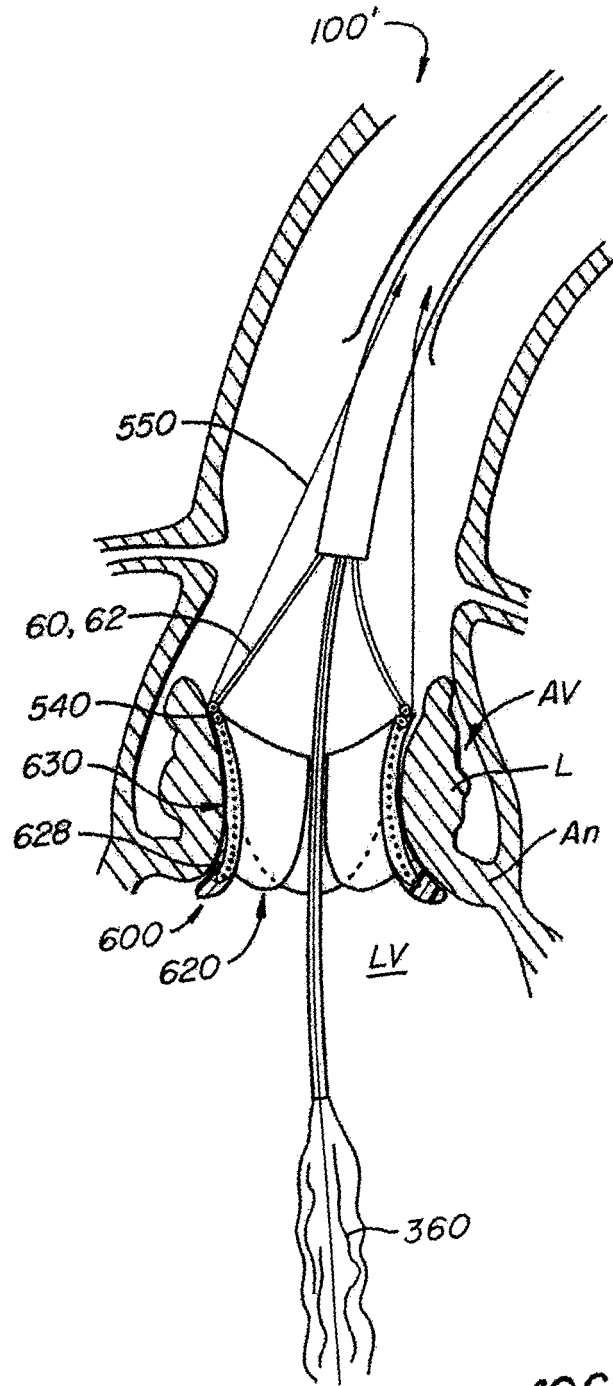

FIG. 40C

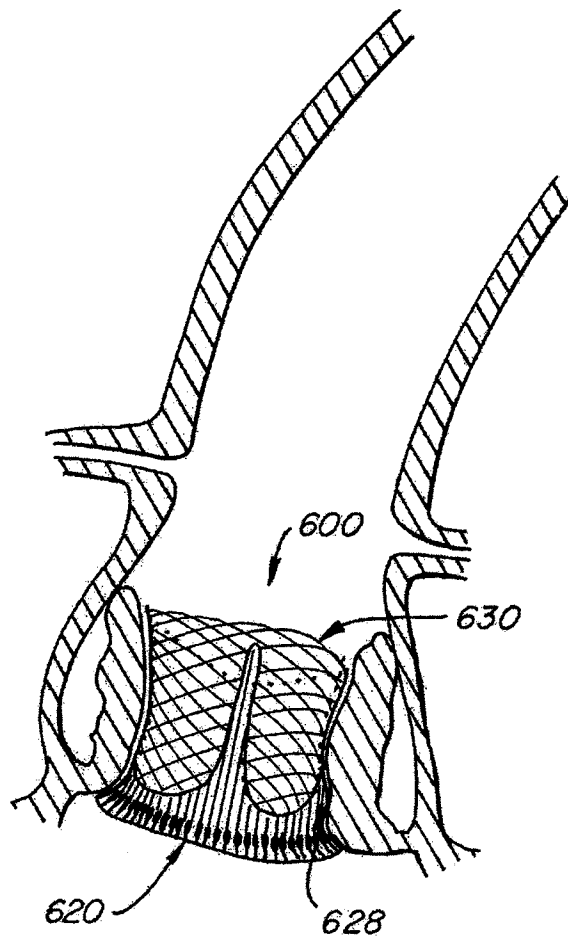

FIG. 40D

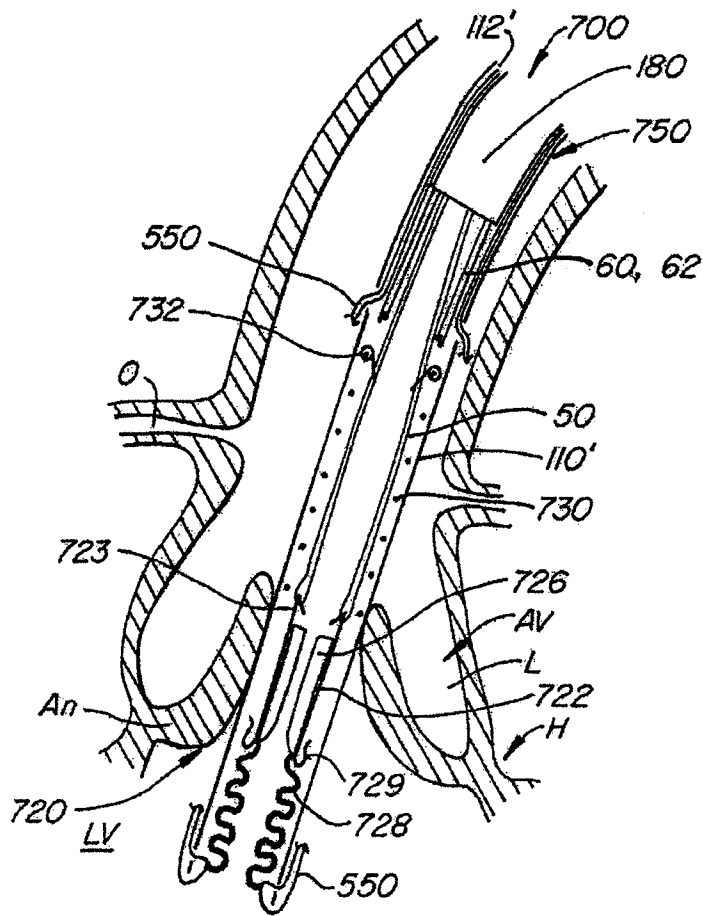

FIG. 41A

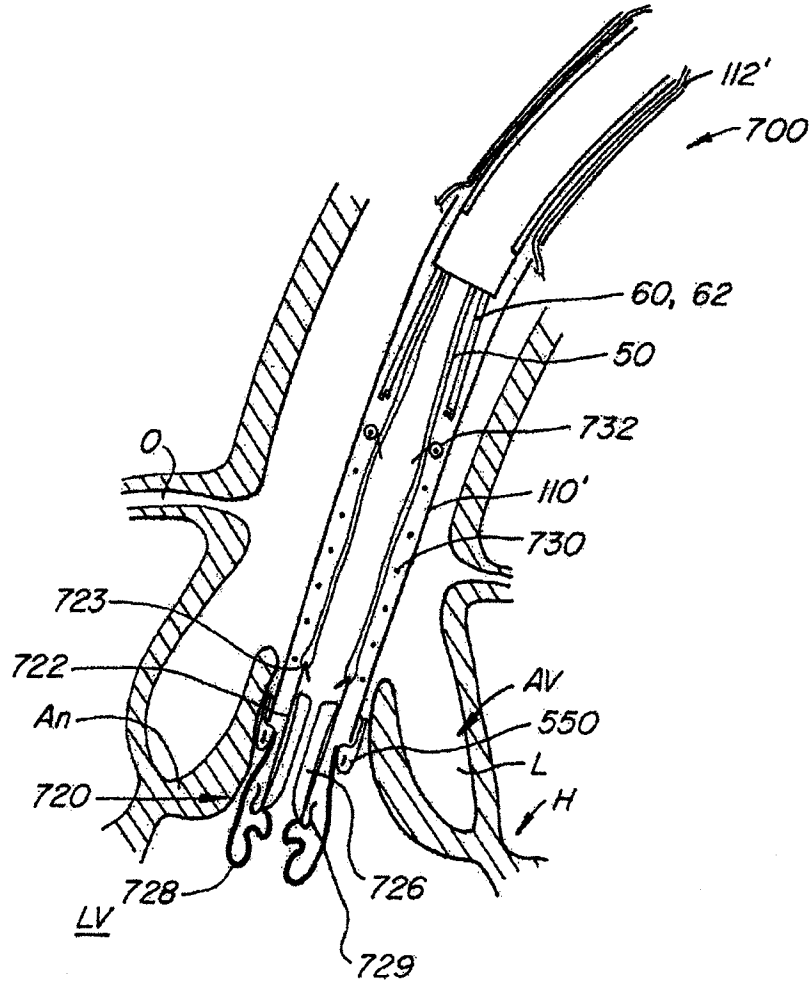

FIG. 41B





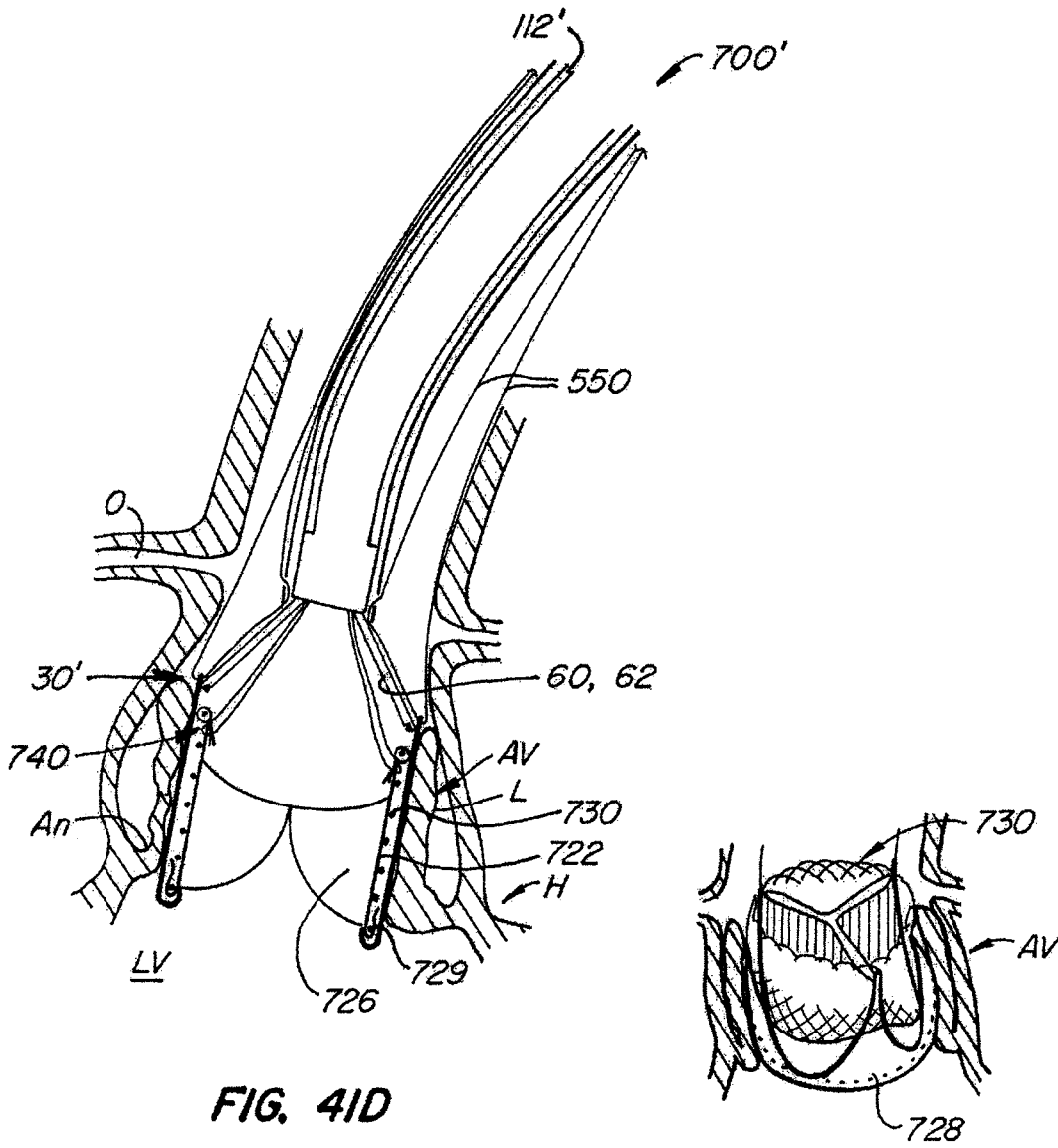

FIG. 41D

FIG. 41E

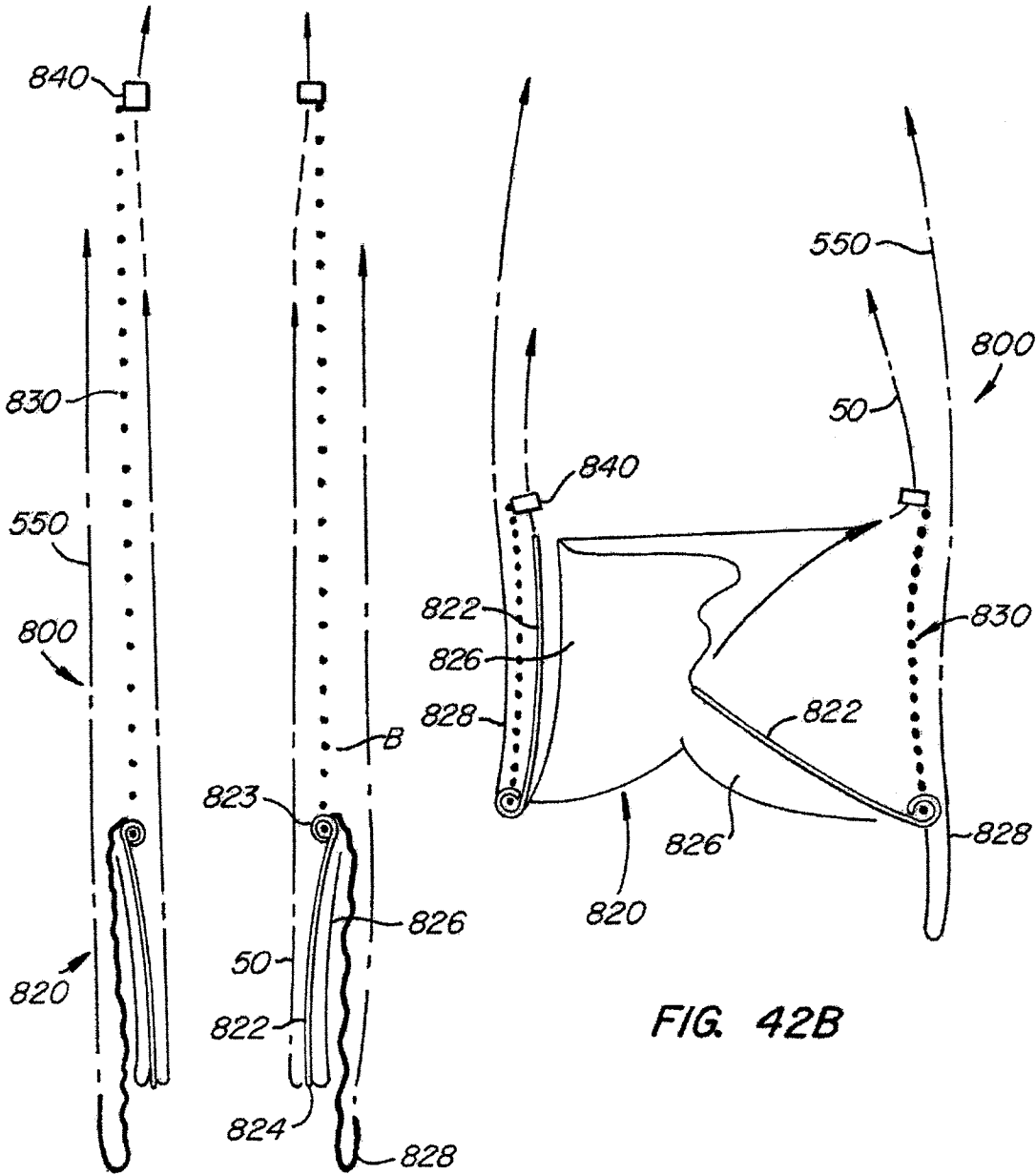

FIG. 42A

FIG. 42B

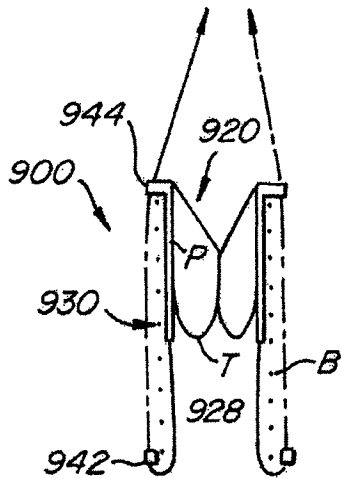

FIG. 43A

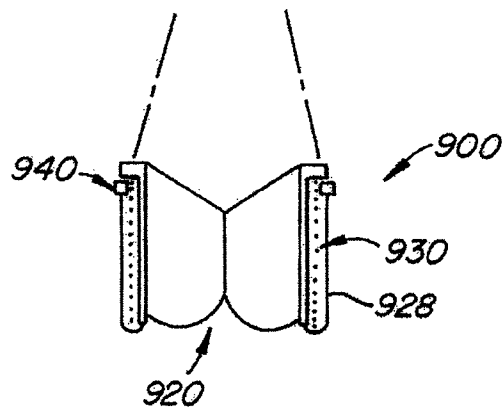

FIG. 43B

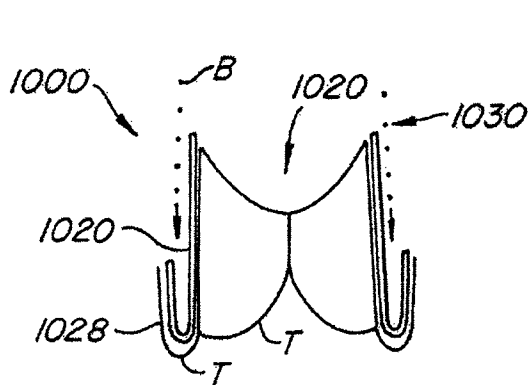

FIG. 44A

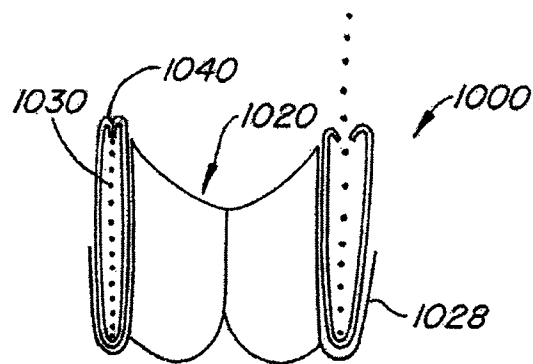

FIG. 44B

**EVERTING HEART VALVE****CROSS-REFERENCE TO RELATED APPLICATION**

This application is a divisional of U.S. application Ser. No. 12/269,213, filed Nov. 12, 2008 now U.S. Pat. No. 8,668,733; which application is a continuation of U.S. application Ser. No. 10/870,340, filed Jun. 16, 2004 now U.S. Pat. No. 7,780,725, entitled "Everting Heart Valve", the disclosures of which are incorporated by reference in their entirety.

**BACKGROUND OF THE INVENTION**

The present invention relates to methods and apparatus for endovascularly replacing a heart valve. More particularly, the present invention relates to methods and apparatus for endovascularly replacing a heart valve with a replacement valve and an expandable and retrievable anchor. The replacement valve preferably is not connected to the expandable anchor and may be wrapped about an end of the anchor, for example, by everting during endovascular deployment.

Heart valve surgery is used to repair or replace diseased heart valves. Valve surgery is an open-heart procedure conducted under general anesthesia. An incision is made through the patient's sternum (sternotomy), and the patient's heart is stopped while blood flow is rerouted through a heart-lung bypass machine.

Valve replacement may be indicated when there is a narrowing of the native heart valve, commonly referred to as stenosis, or when the native valve leaks or regurgitates. When replacing the valve, the native valve is excised and replaced with either a biologic or a mechanical valve. Mechanical valves require lifelong anticoagulant medication to prevent blood clot formation, and clicking of the valve often may be heard through the chest. Biologic tissue valves typically do not require such medication. Tissue valves may be obtained from cadavers or may be porcine or bovine, and are commonly attached to synthetic rings that are secured to the patient's heart.

Valve replacement surgery is a highly invasive operation with significant concomitant risk. Risks include bleeding, infection, stroke, heart attack, arrhythmia, renal failure, adverse reactions to the anesthesia medications, as well as sudden death. 2-5% of patients die during surgery.

Post-surgery, patients temporarily may be confused due to emboli and other factors associated with the heart-lung machine. The first 2-3 days following surgery are spent in an intensive care unit where heart functions can be closely monitored. The average hospital stay is between 1 to 2 weeks, with several more weeks to months required for complete recovery.

In recent years, advancements in minimally invasive surgery and interventional cardiology have encouraged some investigators to pursue percutaneous replacement of the aortic heart valve. See, e.g., U.S. Pat. No. 6,168,614. In many of these procedures, the replacement valve is deployed across the native diseased valve to permanently hold the valve open, thereby alleviating a need to excise the native valve and to position the replacement valve in place of the native valve.

In the endovascular aortic valve replacement procedure, accurate placement of aortic valves relative to coronary ostia and the mitral valve is critical. Standard self-expanding systems have very poor accuracy in deployment, however. Often the proximal end of the stent is not released from the delivery system until accurate placement is verified by fluoroscopy, and the stent typically jumps once released. It is therefore

often impossible to know where the ends of the stent will be with respect to the native valve, the coronary ostia and the mitral valve.

Also, visualization of the way the new valve is functioning prior to final deployment is very desirable. Visualization prior to final and irreversible deployment cannot be done with standard self-expanding systems, however, and the replacement valve is often not fully functional before final deployment.

Another drawback of prior art self-expanding replacement heart valve systems is their lack of radial strength. In order for self-expanding systems to be easily delivered through a delivery sheath, the metal needs to flex and bend inside the delivery catheter without being plastically deformed. In arterial stents, this is not a challenge, and there are many commercial arterial stent systems that apply adequate radial force against the vessel wall and yet can collapse to a small enough of a diameter to fit inside a delivery catheter without plastic deformation. However when the stent has a valve fastened inside it, as is the case in aortic valve replacement, the anchoring of the stent to vessel walls is significantly challenged during diastole. The force to hold back arterial pressure and prevent blood from going back inside the ventricle during diastole will be directly transferred to the stent/vessel wall interface. Therefore, the amount of radial force required to keep the self-expanding stent/valve in contact with the vessel wall and not sliding will be much higher than in stents that do not have valves inside of them. Moreover, a self-expanding stent without sufficient radial force will end up dilating and contracting with each heartbeat, thereby distorting the valve, affecting its function and possibly migrating and dislodging completely. Simply increasing strut thickness of the self-expanding stent is not a practical solution as it runs the risk of larger profile and/or plastic deformation of the self-expanding stent.

In view of drawbacks associated with previously known techniques for endovascularly replacing a heart valve, it would be desirable to provide methods and apparatus that overcome those drawbacks.

**SUMMARY OF THE INVENTION**

One aspect of the present invention provides apparatus for endovascularly replacing a patient's heart valve, the apparatus including: a replacement valve; and an expandable anchor, wherein the replacement valve and expandable anchor are configured for endovascular delivery to the vicinity of the heart valve, and wherein at least a portion of the replacement valve is configured to evert about the anchor during endovascular deployment.

Another aspect of the invention provides a method for endovascularly replacing a patient's heart valve. In some embodiments the method includes the steps of: endovascularly delivering a replacement valve and an expandable anchor to a vicinity of the heart valve; everting at least a portion of the replacement valve about the anchor; and expanding the anchor to a deployed configuration.

Yet another aspect of the invention provides apparatus for endovascularly replacing a patient's heart valve including: an anchor comprising a lip region and a skirt region; and a replacement valve, wherein at least a portion of the replacement valve is configured to evert about the anchor during endovascular deployment, and wherein the lip region and skirt region are configured for percutaneous expansion to engage the patient's heart valve.

Still another aspect of the present invention provides a method for endovascularly replacing a patient's heart valve, the method including: endovascularly delivering a replace-

ment valve and an expandable anchor to a vicinity of the heart valve, endovascularly wrapping at least a portion of the replacement valve about the anchor, and expanding the anchor to a deployed configuration.

Another aspect of the present invention provides apparatus for endovascularly replacing a patient's heart valve, the apparatus including: a replacement valve, and an expandable anchor, wherein the replacement valve and the anchor are configured for endovascular delivery to a vicinity of the patient's heart valve, and wherein at least a portion of the replacement valve is wrapped about an end of the anchor in a deployed configuration.

#### INCORPORATION BY REFERENCE

All publications and patent applications mentioned in this specification are herein incorporated by reference to the same extent as if each individual publication or patent application was specifically and individually indicated to be incorporated by reference.

#### BRIEF DESCRIPTION OF THE DRAWINGS

The novel features of the invention are set forth with particularity in the appended claims. A better understanding of the features and advantages of the present invention will be obtained by reference to the following detailed description that sets forth illustrative embodiments, in which the principles of the invention are utilized, and the accompanying drawings of which:

FIGS. 1A-B are elevational views of a replacement heart valve and anchor according to one embodiment of the invention.

FIGS. 2A-B are sectional views of the anchor and valve of FIG. 1.

FIGS. 3A-B show delivery and deployment of a replacement heart valve and anchor, such as the anchor and valve of FIGS. 1 and 2.

FIGS. 4A-F also show delivery and deployment of a replacement heart valve and anchor, such as the anchor and valve of FIGS. 1 and 2.

FIGS. 5A-F show the use of a replacement heart valve and anchor to replace an aortic valve.

FIGS. 6A-F show the use of a replacement heart valve and anchor with a positive registration feature to replace an aortic valve.

FIG. 7 shows the use of a replacement heart valve and anchor with an alternative positive registration feature to replace an aortic valve.

FIGS. 8A-C show another embodiment of a replacement heart valve and anchor according to the invention.

FIGS. 9A-H show delivery and deployment of the replacement heart valve and anchor of FIG. 8.

FIG. 10 is a cross-sectional drawing of the delivery system used with the method and apparatus of FIGS. 8 and 9.

FIGS. 11A-C show alternative locks for use with replacement heart valves and anchors of this invention.

FIGS. 12A-C show a vessel wall engaging lock for use with replacement heart valves and anchors of this invention.

FIG. 13 demonstrates paravalvular leaking around a replacement heart valve and anchor.

FIG. 14 shows a seal for use with a replacement heart valve and anchor of this invention.

FIGS. 15A-E show alternative arrangements of seals on a replacement heart valve and anchor.

FIGS. 16A-C show alternative seal designs for use with replacement heart valves and anchors.

FIG. 17 show an alternative anchor lock embodiment in an unlocked configuration.

FIGS. 18A-B show the anchor lock of FIG. 17 in a locked configuration.

FIG. 19 shows an alternative anchor deployment tool attachment and release mechanism for use with the invention.

FIG. 20 shows the attachment and release mechanism of FIG. 19 in the process of being released.

FIG. 21 shows the attachment and release mechanism of FIGS. 19 and 20 in a released condition.

FIG. 22 shows an alternative embodiment of a replacement heart valve and anchor and a deployment tool according to the invention in an undeployed configuration.

FIG. 23 shows the replacement heart valve and anchor of FIG. 22 in a partially deployed configuration.

FIG. 24 shows the replacement heart valve and anchor of FIGS. 22 and 23 in a more fully deployed configuration but with the deployment tool still attached.

FIG. 25 shows yet another embodiment of the delivery and deployment apparatus of the invention in use with a replacement heart valve and anchor.

FIG. 26 shows the delivery and deployment apparatus of FIG. 25 in the process of deploying a replacement heart valve and anchor.

FIG. 27 shows an embodiment of the invention employing seals at the interface of the replacement heart valve and anchor and the patient's tissue.

FIG. 28 is a longitudinal cross-sectional view of the seal shown in FIG. 27 in compressed form.

FIG. 29 is a transverse cross-sectional view of the seal shown in FIG. 28.

FIG. 30 is a longitudinal cross-sectional view of the seal shown in FIG. 27 in expanded form.

FIG. 31 is a transverse cross-sectional view of the seal shown in FIG. 30.

FIG. 32 shows yet another embodiment of the replacement heart valve and anchor of this invention in an undeployed configuration.

FIG. 33 shows the replacement heart valve and anchor of FIG. 32 in a deployed configuration.

FIG. 34 shows the replacement heart valve and anchor of FIGS. 32 and 33 deployed in a patient's heart valve.

FIGS. 35A-H show yet another embodiment of a replacement heart valve, anchor and deployment system according to this invention.

FIGS. 36A-E show more detail of the anchor of the embodiment shown in FIGS. 35A-H.

FIGS. 37A-B show other embodiments of the replacement heart valve and anchor of the invention.

FIGS. 38A-C illustrate a method for endovascularly replacing a patient's diseased heart valve.

FIGS. 39A-G are side views, partially in section, as well as an isometric view, illustrating a method for endovascularly replacing a patient's diseased heart valve with an embodiment of the present invention comprising a replacement valve that is not connected to the expandable anchor, the replacement valve wrapped about the anchor, illustratively by everting during deployment.

FIGS. 40A-D are side views, partially in section, illustrating a method for endovascularly replacing a patient's diseased heart valve with another everting embodiment of the present invention.

FIGS. 41A-E are side views, partially in section, illustrating a method for endovascularly replacing a patient's diseased heart valve with yet another everting embodiment of the

5

present invention, wherein the replacement valve and the anchor are telescoped relative to one another during endovascular delivery.

FIGS. 42A-B are side-sectional views of alternative evert-ing apparatus comprising evert-ing valve leaflets.

FIGS. 43A-B, are side-sectional views of further alterna-tive evert-ing apparatus comprising a locking mechanism coupled to the evert-ing segment.

FIGS. 44A-B are side-sectional views of telescoping embodiments of the present invention comprising U-shaped valve frames.

#### DETAILED DESCRIPTION OF THE INVENTION

While preferred embodiments of the present invention have been shown and described herein, it will be obvious to those skilled in the art that such embodiments are provided by way of example only. Numerous variations, changes, and substitutions will now occur to those skilled in the art without departing from the invention. It should be understood that various alternatives to the embodiments of the invention described herein may be employed in practicing the invention. For example, for the two-part locking mechanisms described hereinafter, it will be apparent that the locations of the male and female elements may be reversed. It is intended that the following claims define the scope of the invention and that methods and structures within the scope of these claims and their equivalents be covered thereby.

With reference now to FIGS. 1-4, a first embodiment of replacement heart valve apparatus in accordance with the present invention is described, including a method of actively foreshortening and expanding the apparatus from a delivery configuration and to a deployed configuration. Apparatus 10 comprises replacement valve 20 disposed within and coupled to anchor 30. FIG. 1 schematically illustrate individual cells of anchor 30 of apparatus 10, and should be viewed as if the cylindrical anchor has been cut open and laid flat. FIG. 2 schematically illustrate a detail portion of apparatus 10 in side-section.

Anchor 30 has a lip region 32, a skirt region 34 and a body region 36. First, second and third posts 38a, 38b and 38c, respectively, are coupled to skirt region 34 and extend within lumen 31 of anchor 30. Posts 38 preferably are spaced 120° apart from one another about the circumference of anchor 30.

Anchor 30 preferably is fabricated by using self-expanding patterns (laser cut or chemically milled), braids and materials, such as a stainless steel, nickel-titanium ("Nitinol") or cobalt chromium, but alternatively may be fabricated using balloon-expandable patterns where the anchor is designed to plastically deform to its final shape by means of balloon expansion. Replacement valve 20 is preferably made from biologic tissues, e.g. porcine valve leaflets or bovine or equine pericardium tissues or human cadaver tissue. Alternatively, it can be made from tissue engineered materials (such as extracellular matrix material from Small Intestinal Submucosa (SIS)) or may be prosthetic and made from an elastomeric polymer or silicone, Nitinol or stainless steel mesh or pattern (sputtered, chemically milled or laser cut). The leaflet may also be made of a composite of the elastomeric or silicone materials and metal alloys or other fibers such Kevlar or carbon. Annular base 22 of replacement valve 20 preferably is coupled to skirt region 34 of anchor 30, while commissures 24 of replacement valve leaflets 26 are coupled to and supported by posts 38.

Anchor 30 may be actuated using external non-hydraulic or non-pneumatic force to actively foreshorten in order to increase its radial strength. As shown below, the proximal and distal end regions of anchor 30 may be actuated indepen-

6

dently. The anchor and valve may be placed and expanded in order to visualize their location with respect to the native valve and other anatomical features and to visualize operation of the valve. The anchor and valve may thereafter be repositioned and even retrieved into the delivery sheath or catheter. The apparatus may be delivered to the vicinity of the patient's aortic valve in a retrograde approach in a catheter having a diameter no more than 23 french, preferably no more than 21 french, more preferably no more than 19 french, or more preferably no more than 17 french. Upon deployment the anchor and replacement valve capture the native valve leaflets and positively lock to maintain configuration and position.

A deployment tool is used to actuate, reposition, lock and/or retrieve anchor 30. In order to avoid delivery of anchor 30 on a balloon for balloon expansion, a non-hydraulic or non-pneumatic anchor actuator is used. In this embodiment, the actuator is a deployment tool that includes distal region control wires 50, control rods or tubes 60 and proximal region control wires 62. Locks 40 include posts or arms 38 preferably with male interlocking elements 44 extending from skirt region 34 and mating female interlocking elements 42 in lip region 32. Male interlocking elements 44 have eyelets 45. Control wires 50 pass from a delivery system for apparatus 10 through female interlocking elements 42, through eyelets 45 of male interlocking elements 44, and back through female interlocking elements 42, such that a double strand of wire 50 passes through each female interlocking element 42 for manipulation by a medical practitioner external to the patient to actuate and control the anchor by changing the anchor's shape. Control wires 50 may comprise, for example, strands of suture.

Tubes 60 are reversibly coupled to apparatus 10 and may be used in conjunction with wires 50 to actuate anchor 30, e.g., to foreshorten and lock apparatus 10 in the fully deployed configuration. Tubes 60 also facilitate repositioning and retrieval of apparatus 10, as described hereinafter. For example, anchor 30 may be foreshortened and radially expanded by applying a distally directed force on tubes 60 while proximally retracting wires 50. As seen in FIG. 3, control wires 62 pass through interior lumens 61 of tubes 60. This ensures that tubes 60 are aligned properly with apparatus 10 during deployment and foreshortening. Control wires 62 can also actuate anchor 60; proximally directed forces on control wires 62 contacts the proximal lip region 32 of anchor 30. Wires 62 also act to couple and decouple tubes 60 from apparatus 10. Wires 62 may comprise, for example, strands of suture.

FIGS. 1A and 2A illustrate anchor 30 in a delivery configuration or in a partially deployed configuration (e.g., after dynamic self-expansion from a constrained delivery configuration within a delivery sheath). Anchor 30 has a relatively long length and a relatively small width in the delivery or partially deployed configuration, as compared to the foreshortened and fully deployed configuration of FIGS. 1B and 2B.

In FIGS. 1A and 2A, replacement valve 20 is collapsed within lumen 31 of anchor 30. Retraction of wires 50 relative to tubes 60 foreshortens anchor 30, which increases the anchor's width while decreasing its length. Such foreshortening also properly seats replacement valve 20 within lumen 31 of anchor 30. Imposed foreshortening will enhance radial force applied by apparatus 10 to surrounding tissue over at least a portion of anchor 30. In some embodiments, the anchor is capable of exerting an outward radial force on surrounding tissue to engage the tissue in such way to prevent migration of anchor. This outward radial force is preferably greater than 2 psi, more preferably greater than 4 psi, more preferably

greater than 6 psi, more preferably greater than 8 psi, more preferably greater than 10 psi, more preferably greater than 20 psi, or more preferably greater than 30 psi. Enhanced radial force of the anchor is also important for enhanced crush resistance of the anchor against the surrounding tissue due to the healing response (fibrosis and contraction of annulus over a longer period of time) or to dynamic changes of pressure and flow at each heart beat. In an alternative embodiment, the anchor pattern or braid is designed to have gaps or areas where the native tissue is allowed to protrude through the anchor slightly (not shown) and, as the foreshortening is applied, the tissue and anchor become intertwined and immobilized. This feature would provide additional means to prevent anchor migration and enhance long-term stability of the device.

Deployment of apparatus 10 is fully reversible until lock 40 has been locked via mating of male interlocking elements 44 with female interlocking elements 42. Deployment is then completed by decoupling tubes 60 from lip section 32 of anchor 30 by retracting one end of each wire 62 relative to the other end of the wire, and by retracting one end of each wire 50 relative to the other end of the wire until each wire has been removed from eyelet 45 of its corresponding male interlocking element 44.

As best seen in FIG. 2B, body region 36 of anchor 30 optionally may comprise barb elements 37 that protrude from anchor 30 in the fully deployed configuration, for example, for engagement of a patient's native valve leaflets and to preclude migration of the apparatus.

With reference now to FIG. 3, a delivery and deployment system for a self-expanding embodiment of apparatus 10 including a sheath 110 having a lumen 112. Self-expanding anchor 30 is collapsible to a delivery configuration within lumen 112 of sheath 110, such that apparatus 10 may be delivered via delivery system 100. As seen in FIG. 3A, apparatus 10 may be deployed from lumen 112 by retracting sheath 110 relative to apparatus 10, control wires 50 and tubes 60, which causes anchor 30 to dynamically self-expand to a partially deployed configuration. Control wires 50 then are retracted relative to apparatus 10 and tubes 60 to impose foreshortening upon anchor 30, as seen in FIG. 3B.

During foreshortening, tubes 60 push against lip region 32 of anchor 30, while wires 50 pull on posts 38 of the anchor. Wires 62 may be retracted along with wires 50 to enhance the distally directed pushing force applied by tubes 60 to lip region 32. Continued retraction of wires 50 relative to tubes 60 would lock locks 40 and fully deploy apparatus 10 with replacement valve 20 properly seated within anchor 30, as in FIGS. 1B and 2B. Apparatus 10 comprises enhanced radial strength in the fully deployed configuration as compared to the partially deployed configuration of FIG. 3A. Once apparatus 10 has been fully deployed, wires 50 and 62 may be removed from apparatus 10, thereby separating delivery system 100 and tubes 60 from the apparatus.

Deployment of apparatus 10 is fully reversible until locks 40 have been actuated. For example, just prior to locking the position of the anchor and valve and the operation of the valve may be observed under fluoroscopy. If the position needs to be changed, by alternately relaxing and reapplying the proximally directed forces exerted by control wires 50 and/or control wires 62 and the distally directed forces exerted by tubes 60, expansion and contraction of the lip and skirt regions of anchor 30 may be independently controlled so that the anchor and valve can be moved to, e.g., avoid blocking the coronary ostia or impinging on the mitral valve. Apparatus 10 may also be completely retrieved within lumen 112 of sheath 110 by simultaneously proximally retracting wires 50 and

tubes 60/wires 62 relative to sheath 110. Apparatus 10 then may be removed from the patient or repositioned for subsequent redeployment.

Referring now to FIG. 4, step-by-step deployment of apparatus 10 via delivery system 100 is described. In FIG. 4A, sheath 110 is retracted relative to apparatus 10, wires 50 and tubes 60, thereby causing self-expandable anchor 30 to dynamically self-expand apparatus 10 from the collapsed delivery configuration within lumen 112 of sheath 110 to the partially deployed configuration. Apparatus 10 may then be dynamically repositioned via tubes 60 to properly orient the apparatus, e.g. relative to a patient's native valve leaflets.

In FIG. 4B, control wires 50 are retracted while tubes 60 are advanced, thereby urging lip region 32 of anchor 30 in a distal direction while urging posts 38 of the anchor in a proximal direction. This foreshortens apparatus 10, as seen in FIG. 4C. Deployment of apparatus 10 is fully reversible even after foreshortening has been initiated and has advanced to the point illustrated in FIG. 4C.

In FIG. 4D, continued foreshortening causes male interlocking elements 44 of locks 40 to engage female interlocking elements 42. The male elements mate with the female elements, thereby locking apparatus 10 in the foreshortened configuration, as seen in FIG. 4E. Wires 50 are then pulled through eyelets 45 of male elements 44 to remove the wires from apparatus 10, and wires 62 are pulled through the proximal end of anchor 30 to uncouple tubes 60 from the apparatus, thereby separating delivery system 100 from apparatus 10. Fully deployed apparatus 10 is shown in FIG. 4F.

Referring to FIG. 5, a method of endovascularly replacing a patient's diseased aortic valve with apparatus 10 and delivery system 100 is described. As seen in FIG. 5A, sheath 110 of delivery system 100, having apparatus 10 disposed therein, is endovascularly advanced over guide wire G, preferably in a retrograde fashion (although an antegrade or hybrid approach alternatively may be used), through a patient's aorta A to the patient's diseased aortic valve AV. A nosecone 102 precedes sheath 110 in a known manner. In FIG. 5B, sheath 110 is positioned such that its distal region is disposed within left ventricle LV of the patient's heart H.

Apparatus 10 is deployed from lumen 112 of sheath 110, for example, under fluoroscopic guidance, such that anchor 30 of apparatus 10 dynamically self-expands to a partially deployed configuration, as in FIG. 5C. Advantageously, apparatus 10 may be retracted within lumen 112 of sheath 110 via wires 50—even after anchor 30 has dynamically expanded to the partially deployed configuration, for example, to abort the procedure or to reposition apparatus 10 or delivery system 100. As yet another advantage, apparatus 10 may be dynamically repositioned, e.g. via sheath 110 and/or tubes 60, in order to properly align the apparatus relative to anatomical landmarks, such as the patient's coronary ostia or the patient's native valve leaflets L. When properly aligned, skirt region 34 of anchor 30 preferably is disposed distal of the leaflets, while body region 36 is disposed across the leaflets and lip region 32 is disposed proximal of the leaflets.

Once properly aligned, wires 50 are retracted relative to tubes 60 to impose foreshortening upon anchor 30 and expand apparatus 10 to the fully deployed configuration, as in FIG. 5D. Foreshortening increases the radial strength of anchor 30 to ensure prolonged patency of valve annulus An, as well as to provide a better seal for apparatus 10 that reduces paravalvular regurgitation. As seen in FIG. 5E, locks 40 maintain imposed foreshortening. Replacement valve 20 is properly seated within anchor 30, and normal blood flow between left ventricle LV and aorta A is thereafter regulated by apparatus



10. Deployment of apparatus 10 advantageously is fully reversible until locks 40 have been actuated.

As seen in FIG. 5F, wires 50 are pulled from eyelets 45 of male elements 44 of locks 40, tubes 60 are decoupled from anchor 30, e.g. via wires 62, and delivery system 100 is removed from the patient, thereby completing deployment of apparatus 10. Optional barb elements 37 engage the patient's native valve leaflets, e.g. to preclude migration of the apparatus and/or reduce paravalvular regurgitation.

With reference now to FIG. 6, a method of endovascularly replacing a patient's diseased aortic valve with apparatus 10 is provided, wherein proper positioning of the apparatus is ensured via positive registration of a modified delivery system to the patient's native valve leaflets. In FIG. 6A, modified delivery system 100' delivers apparatus 10 to diseased aortic valve AV within sheath 110. As seen in FIGS. 6B and 6C, apparatus 10 is deployed from lumen 112 of sheath 110, for example, under fluoroscopic guidance, such that anchor 30 of apparatus 10 dynamically self-expands to a partially deployed configuration. As when deployed via delivery system 100, deployment of apparatus 10 via delivery system 100' is fully reversible until locks 40 have been actuated.

Delivery system 100' comprises leaflet engagement element 120, which preferably self-expands along with anchor 30. Engagement element 120 is disposed between tubes 60 of delivery system 100' and lip region 32 of anchor 30. Element 120 releasably engages the anchor. As seen in FIG. 6C, the element is initially deployed proximal of the patient's native valve leaflets L. Apparatus 10 and element 120 then may be advanced/dynamically repositioned until the engagement element positively registers against the leaflets, thereby ensuring proper positioning of apparatus 10. Also, delivery system 100' includes filter structure 61A (e.g., filter membrane or braid) as part of push tubes 60 to act as an embolic protection element. Emboli can be generated during manipulation and placement of anchor, from either diseased native leaflet or surrounding aortic tissue, and can cause blockage. Arrows 61B in FIG. 6E show blood flow through filter structure 61A where blood is allowed to flow but emboli is trapped in the delivery system and removed with it at the end of the procedure.

Alternatively, foreshortening may be imposed upon anchor 30 while element 120 is disposed proximal of the leaflets, as in FIG. 6D. Upon positive registration of element 120 against leaflets L, element 120 precludes further distal migration of apparatus 10 during additional foreshortening, thereby reducing a risk of improperly positioning the apparatus. FIG. 6E details engagement of element 120 against the native leaflets. As seen in FIG. 6F, once apparatus 10 is fully deployed, element 120, wires 50 and tubes 60 are decoupled from the apparatus, and delivery system 100' is removed from the patient, thereby completing the procedure.

With reference to FIG. 7, an alternative embodiment of the apparatus of FIG. 6 is described, wherein leaflet engagement element 120 is coupled to anchor 30 of apparatus 10', rather than to delivery system 100. Engagement element 120 remains implanted in the patient post-deployment of apparatus 10'. Leaflets L are sandwiched between lip region 32 of anchor 30 and element 120 in the fully deployed configuration. In this manner, element 120 positively registers apparatus 10' relative to the leaflets and precludes distal migration of the apparatus over time.

Referring now to FIG. 8, an alternative delivery system adapted for use with a balloon expandable embodiment of the present invention is described. In FIG. 8A, apparatus 10" comprises anchor 30' that may be fabricated from balloon-expandable materials. Delivery system 100" comprises inflat-

able member 130 disposed in a deflated configuration within lumen 31 of anchor 30'. In FIG. 8B, optional outer sheath 110 is retracted, and inflatable member 130 is inflated to expand anchor 30' to the fully deployed configuration. As inflatable member 130 is being deflated, as in earlier embodiments, wires 50 and 62 and tubes 60 may be used to assist deployment of anchor 30' and actuation of locks 40, as well as to provide reversibility and retrievability of apparatus 10" prior to actuation of locks 40. Next, wires 50 and 62 and tubes 60 are removed from apparatus 10", and delivery system 100" is removed, as seen in FIG. 8C.

As an alternative delivery method, anchor 30' may be partially deployed via partial expansion of inflatable member 130. The inflatable member would then be advanced within replacement valve 20 prior to inflation of inflatable member 130 and full deployment of apparatus 10". Inflation pressures used will range from about 3 to 6 atm, or more preferably from about 4 to 5 atm, though higher and lower atm pressures may also be used (e.g., greater than 3 atm, more preferably greater than 4 atm, more preferably greater than 5 atm, or more preferably greater than 6 atm). Advantageously, separation of inflatable member 130 from replacement valve 20, until partial deployment of apparatus 10" at a treatment site, is expected to reduce a delivery profile of the apparatus, as compared to previously known apparatus. This profile reduction may facilitate retrograde delivery and deployment of apparatus 10", even when anchor 30' is balloon-expandable.

Although anchor 30' has illustratively been described as fabricated from balloon-expandable materials, it should be understood that anchor 30' alternatively may be fabricated from self-expanding materials whose expansion optionally may be balloon-assisted. In such a configuration, anchor 30' would expand to a partially deployed configuration upon removal of outer sheath 110. If required, inflatable member 130 then would be advanced within replacement valve 20 prior to inflation. Inflatable member 130 would assist full deployment of apparatus 10", for example, when the radial force required to overcome resistance from impinging tissue were too great to be overcome simply by manipulation of wires 50 and tubes 60. Advantageously, optional placement of inflatable member 130 within replacement valve 20, only after dynamic self-expansion of apparatus 10" to the partially deployed configuration at a treatment site, is expected to reduce a delivery profile of the apparatus, as compared to previously known apparatus. This reduction may facilitate retrograde delivery and deployment of apparatus 10".

With reference to FIGS. 9 and 10, methods and apparatus for a balloon-assisted embodiment of the present invention are described in greater detail. FIGS. 9 and 10 illustratively show apparatus 10' of FIG. 7 used in combination with delivery system 100" of FIG. 8. FIG. 10 illustrates a sectional view of delivery system 100". Inner shaft 132 of inflatable member 130 preferably is about 4 Fr in diameter, and comprises lumen 133 configured for passage of guidewire G, having a diameter of about 0.035", therethrough. Push tubes 60 and pull wires 50 pass through guidetube 140, which preferably has a diameter of about 15 Fr or smaller. Guide tube 140 is disposed within lumen 112 of outer sheath 110, which preferably has a diameter of about 17 Fr or smaller.

In FIG. 9A, apparatus 10' is delivered to diseased aortic valve AV within lumen 112 of sheath 110. In FIG. 9B, sheath 110 is retracted relative to apparatus 10' to dynamically self-expand the apparatus to the partially deployed configuration. Also retracted and removed is nosecone 102, which is attached to a pre-slit lumen (not shown) that facilitates its

11

removal prior to loading and advancing of a regular angioplasty balloon catheter over guidewire and inside delivery system 110.

In FIG. 9C, pull wires 50 and push tubes 60 are manipulated from external to the patient to foreshorten anchor 30 and sufficiently expand lumen 31 of the anchor to facilitate advancement of inflatable member 130 within replacement valve 20. Also shown is the tip of an angioplasty catheter 130 being advanced through delivery system 110.

The angioplasty balloon catheter or inflatable member 130 then is advanced within the replacement valve, as in FIG. 9D, and additional foreshortening is imposed upon anchor 30 to actuate locks 40, as in FIG. 9E. The inflatable member is inflated to further displace the patient's native valve leaflets L and ensure adequate blood flow through, and long-term patency of, replacement valve 20, as in FIG. 9F. Inflatable member 130 then is deflated and removed from the patient, as in FIG. 9G. A different size angioplasty balloon catheter could be used repeat the same step if deemed necessary by the user. Push tubes 60 optionally may be used to further set leaflet engagement element 120, or optional barbs B along posts 38, more deeply within leaflets L, as in FIG. 9H. Then, delivery system 100" is removed from the patient, thereby completing percutaneous heart valve replacement.

As will be apparent to those of skill in the art, the order of imposed foreshortening and balloon expansion described in FIGS. 9 and 10 is only provided for the sake of illustration. The actual order may vary according to the needs of a given patient and/or the preferences of a given medical practitioner. Furthermore, balloon-assist may not be required in all instances, and the inflatable member may act merely as a safety precaution employed selectively in challenging clinical cases.

Referring now to FIG. 11, alternative locks for use with apparatus of the present invention are described. In FIG. 11A, lock 40' comprises male interlocking element 44 as described previously. However, female interlocking element 42' illustratively comprises a triangular shape, as compared to the round shape of interlocking element 42 described previously. The triangular shape of female interlocking element 42' may facilitate mating of male interlocking element 44 with the female interlocking element without necessitating deformation of the male interlocking element.

In FIG. 11B, lock 40" comprises alternative male interlocking element 44' having multiple in-line arrowheads 46 along posts 38. Each arrowhead comprises resiliently deformable appendages 48 to facilitate passage through female interlocking element 42. Appendages 48 optionally comprise eyelets 49, such that control wire 50 or a secondary wire may pass therethrough to constrain the appendages in the deformed configuration. To actuate lock 40", one or more arrowheads 46 of male interlocking element 44' are drawn through female interlocking element 42, and the wire is removed from eyelets 49, thereby causing appendages 48 to resiliently expand and actuate lock 40".

Advantageously, providing multiple arrowheads 46 along posts 38 yields a ratchet that facilitates in-vivo determination of a degree of foreshortening imposed upon apparatus of the present invention. Furthermore, optionally constraining appendages 48 of arrowheads 46 via eyelets 49 prevents actuation of lock 40" (and thus deployment of apparatus of the present invention) even after male element 44' has been advanced through female element 42. Only after a medical practitioner has removed the wire constraining appendages 48 is lock 40" fully engaged and deployment no longer reversible.

12

Lock 40'" of FIG. 11C is similar to lock 40" of FIG. 11B, except that optional eyelets 49 on appendages 48 have been replaced by optional overtube 47. Overtube 47 serves a similar function to eyelets 49 by constraining appendages 48 to prevent locking until a medical practitioner has determined that apparatus of the present invention has been foreshortened and positioned adequately at a treatment site. Overtube 47 is then removed, which causes the appendages to resiliently expand, thereby fully actuating lock 40'".

With reference to FIG. 12, an alternative locking mechanism is described that is configured to engage the patient's aorta. Male interlocking elements 44'" of locks 40'" comprise arrowheads 46' having sharpened appendages 48'. Upon expansion from the delivery configuration of FIG. 12A to the foreshortened configuration of FIG. 12B, apparatus 10 positions sharpened appendages 48' adjacent the patient's aorta A. Appendages 48' engage the aortic wall and reduce a risk of device migration over time.

With reference now to FIG. 13, a risk of paravalvular leakage or regurgitation around apparatus of the present invention is described. In FIG. 13, apparatus 10 has been implanted at the site of diseased aortic valve AV, for example, using techniques described hereinabove. The surface of native valve leaflets L is irregular, and interface I between leaflets L and anchor 30 may comprise gaps where blood B may seep through. Such leakage poses a risk of blood clot formation or insufficient blood flow.

Referring to FIG. 14, optional elements for reducing regurgitation or leakage are described. Compliant sacs 200 may be disposed about the exterior of anchor 30 to provide a more efficient seal along irregular interface I. Sacs 200 may be filled with an appropriate material, for example, water, blood, foam or a hydrogel. Alternative fill materials will be apparent.

With reference to FIG. 15, illustrative arrangements for sacs 200 are provided. In FIG. 15A, sacs 200 are provided as discrete sacs at different positions along the height of anchor 30. In FIG. 15B, the sacs are provided as continuous cylinders at various heights. In FIG. 15C, a single sac is provided with a cylindrical shape that spans multiple heights. The sacs of FIG. 15D are discrete, smaller and provided in larger quantities. FIG. 15E provides a spiral sac. Alternative sac configurations will be apparent to those of skill in the art.

With reference to FIG. 16, exemplary techniques for fabricating sacs 200 are provided. In FIG. 16A, sacs 200 comprise 'fish-scale' slots 202 that may be back-filled, for example, with ambient blood passing through replacement valve 20. In FIG. 16B, the sacs comprise pores 204 that may be used to fill the sacs. In FIG. 16C, the sacs open to lumen 31 of anchor 30 and are filled by blood washing past the sacs as the blood moves through apparatus 10.

FIGS. 17 and 18 show yet another alternative embodiment of the anchor lock. Anchor 300 has a plurality of male interlocking elements 302 having eyelets 304 formed therein. Male interlocking elements are connected to braided structure 300 by inter-weaving elements 302 (and 308) or alternatively suturing, soldering, welding, or connecting with adhesive. Valve commissures 24 are connected to male interlocking elements 302 along their length. Replacement valve 20 annular base 22 is connected to the distal end 34 of anchor 300 (or 30) as is illustrated in FIGS. 1A and 1B. Male interlocking elements 302 also include holes 306 that mate with tabs 310 extending into holes 312 in female interlocking elements 308. To lock, control wires 314 passing through eyelets 304 and holes 312 are pulled proximally with respect to the proximal end of braided anchor 300 to draw the male interlocking elements through holes 312 so that tabs 310 engage holes 306 in male interlocking elements 302. Also

13

shown is release wires **314B** that pass through eyelet **304B** in female interlocking element **308**. If needed, during the procedure, the user may pull on release wires **314B**, thereby reversing orientation of tabs **310**, releasing the anchor and allowing for repositioning of the device or its removal from the patient. Only when finally positioned as desired by the operating physician, would release wire **314B** and control wire **314** be cut and removed from the patient with the delivery system.

FIGS. **19-21** show an alternative way of releasing the connection between the anchor and its actuating tubes and control wires. Control wires **62** extend through tubes **60** from outside the patient, loop through the proximal region of anchor **30** and extend partially back into tube **60**. The doubled up portion of control wire **62** creates a force fit within tube **60** that maintains the control wire's position with respect to tube **60** when all control wires **62** are pulled proximally to place a proximally directed force on anchor **30**. When a single control wire **62** is pulled proximally, however, the frictional fit between that control wire and the tube in which it is disposed is overcome, enabling the end **63** of control wire **62** to pull free of the tube, as shown in FIG. **21**, thereby releasing anchor **30**.

FIGS. **22-24** show an alternative embodiment of the anchor. Anchor **350** is made of a metal braid, such as Nitinol or stainless steel. A replacement valve **354** is disposed within anchor **350** and supported by a replacement valve support, such as the posts described in earlier embodiments. Anchor **350** preferably is fabricated from a single strand of metal wire wound into the braid. It is expected that fabricating anchor **350** from a single strand of wire will facilitate deployment of the anchor, as well as retrieval of the anchor, by more evenly distributing forces applied to the anchor. Fabrication from a single strand is also expected to facilitate coupling of replacement valve **354** to the anchor, as well as coupling and decoupling of control wires (not shown) and tubes **352** thereto. Anchor **350** is actuated in substantially the same way as anchor **30** of FIGS. **1-4** through the application of proximally and distally directed forces from control wires and tubes **352** and may be locked in its expanded deployed configuration, as described above. The employed configuration of anchor **354** may have the shape and anchoring characteristics described with respect to other embodiments as well.

The braid forming anchor **350** (as well as that forming previously described anchor **30**) optionally may be locally increased in diameter, e.g. via dipping in silicone or a hydrogel, in order to provide a better or complete seal against the patient's anatomy. An improved seal is expected to reduce paravalvular leakage, as well as migration of the anchor over time. The local increase in diameter of the braid may, for example, be provided over a full radial segment of anchor **350**.

FIGS. **25** and **26** show yet another embodiment of the delivery and deployment apparatus of the invention. As an alternative to the balloon expansion method described with respect to FIG. **8**, in this embodiment the nosecone (e.g., element **102** of FIG. **5**) is replaced by an angioplasty balloon catheter **360**. Thus, angioplasty balloon catheter **360** precedes sheath **110** on guidewire **G**. When anchor **30** and valve **20** are expanded through the operation of tubes **60** and the control wires (not shown) as described above, balloon catheter **360** is retracted proximally within the expanded anchor and valve and expanded further as described above with respect to FIG. **8**.

As an alternative, or in addition, to further expansion of balloon catheter **360** within valve **20** and expanded anchor **30** to further expand the anchor, the balloon may be deflated

14

prior to proximal retraction within and past the valve and anchor. In this manner, balloon catheter **360** may act as an atraumatic nosecone during delivery of valve **20** and anchor **30**, but then may be deflated to provide a reduced profile, as compared to a standard nosecone, during retrieval of the balloon catheter through the deployed valve. It is expected that a smaller balloon catheter **360** may be provided when the catheter is utilized merely in place of a nosecone than when the catheter is also utilized to complete expansion of anchor **30**.

FIGS. **27-31** show seals **370** that expand over time to seal the interface between the anchor and valve and the patient's tissue. Seals **370** are preferably formed from Nitinol wire surrounded by an expandable foam. As shown in cross-section in FIGS. **28** and **29**, at the time of deployment, the foam **372** is compressed about the wire **374** and held in the compressed form by a time-released coating **376**. After deployment, coating **376** dissolves in vivo to allow foam **372** to expand, as shown in FIGS. **30** and **31**.

FIGS. **32-34** show another way to seal the replacement valve against leakage. A fabric seal **380** extends from the distal end of valve **20** and back proximally over anchor **30** during delivery. When deployed, as shown in FIGS. **33** and **34**, fabric seal **380** bunches up to create fabric flaps and pockets that extend into spaces formed by the native valve leaflets **382**, particularly when the pockets are filled with blood in response to backflow blood pressure. This arrangement creates a seal around the replacement valve.

FIGS. **35A-H** show another embodiment of a replacement heart valve apparatus in accordance with the present invention. Apparatus **450** comprises replacement valve **460** (see FIGS. **37B** and **38C**) disposed within and coupled to anchor **470**. Replacement valve **460** is preferably biologic, e.g. porcine, but alternatively may be synthetic. Anchor **470** preferably is fabricated from self-expanding materials, such as a stainless steel wire mesh or a nickel-titanium alloy ("Nitinol"), and comprises lip region **472**, skirt region **474**, and body regions **476a**, **476b** and **476c**. Replacement valve **460** preferably is coupled to skirt region **474**, but alternatively may be coupled to other regions of the anchor. As described hereinbelow, lip region **472** and skirt region **474** are configured to expand and engage/capture a patient's native valve leaflets, thereby providing positive registration, reducing paravalvular regurgitation, reducing device migration, etc.

As seen in FIG. **35A**, apparatus **450** is collapsible to a delivery configuration, wherein the apparatus may be delivered via delivery system **410**. Delivery system **410** comprises sheath **420** having lumen **422**, as well as wires **424a** and **424b** seen in FIGS. **35D-35G**. Wires **424a** are configured to expand skirt region **474** of anchor **470**, as well as replacement valve **460** coupled thereto, while wires **424b** are configured to expand lip region **472**.

As seen in FIG. **35B**, apparatus **450** may be delivered and deployed from lumen **422** of catheter **420** while the apparatus is disposed in the collapsed delivery configuration. As seen in FIGS. **35B-35D**, catheter **420** is retracted relative to apparatus **450**, which causes anchor **470** to dynamically self-expand to a partially deployed configuration. Wires **424a** are then retracted to expand skirt region **474**, as seen in FIGS. **35E** and **35F**. Preferably, such expansion may be maintained via locking features described hereinafter.

In FIG. **35G**, wires **424b** are retracted to expand lip region **472** and fully deploy apparatus **450**. As with skirt region **474**, expansion of lip region **472** preferably may be maintained via locking features. After both lip region **472** and skirt region **474** have been expanded, wires **424** may be removed from

apparatus 450, thereby separating delivery system 410 from the apparatus. Delivery system 410 then may be removed, as seen in FIG. 35H.

As will be apparent to those of skill in the art, lip region 472 optionally may be expanded prior to expansion of skirt region 474. As yet another alternative, lip region 472 and skirt region 474 optionally may be expanded simultaneously, in parallel, in a step-wise fashion or sequentially. Advantageously, delivery of apparatus 450 is fully reversible until lip region 472 or skirt region 474 has been locked in the expanded configuration.

With reference now to FIGS. 36A-E, individual cells of anchor 470 of apparatus 450 are described to detail deployment and expansion of the apparatus. In FIG. 36A, individual cells of lip region 472, skirt region 474 and body regions 476a, 476b and 476c are shown in the collapsed delivery configuration, as they would appear while disposed within lumen 422 of sheath 420 of delivery system 410 of FIG. 35. A portion of the cells forming body regions 476, for example, every 'nth' row of cells, comprises locking features.

Body region 476a comprises male interlocking element 482 of lip lock 480, while body region 476b comprises female interlocking element 484 of lip lock 480. Male element 482 comprises eyelet 483. Wire 424b passes from female interlocking element 484 through eyelet 483 and back through female interlocking element 484, such that there is a double strand of wire 424b that passes through lumen 422 of catheter 420 for manipulation by a medical practitioner external to the patient. Body region 476b further comprises male interlocking element 492 of skirt lock 490, while body region 476c comprises female interlocking element 494 of the skirt lock. Wire 424a passes from female interlocking element 494 through eyelet 493 of male interlocking element 492, and back through female interlocking element 494. Lip lock 480 is configured to maintain expansion of lip region 472, while skirt lock 490 is configured to maintain expansion of skirt region 474.

In FIG. 36B, anchor 470 is shown in the partially deployed configuration, e.g., after deployment from lumen 422 of sheath 420. Body regions 476, as well as lip region 472 and skirt region 474, self-expand to the partially deployed configuration. Full deployment is then achieved by retracting wires 424 relative to anchor 470, and expanding lip region 472 and skirt region 474 outward, as seen in FIGS. 36C and 36D. As seen in FIG. 36E, expansion continues until the male elements engage the female interlocking elements of lip lock 480 and skirt lock 490, thereby maintaining such expansion (lip lock 480 shown in FIG. 36E). Advantageously, deployment of apparatus 450 is fully reversible until lip lock 480 and/or skirt lock 490 has been actuated.

With reference to FIGS. 37A-B, isometric views, partially in section, further illustrate apparatus 450 in the fully deployed and expanded configuration. FIG. 37A illustrates the wireframe structure of anchor 470, while FIG. 37B illustrates an embodiment of anchor 470 covered in a biocompatible material B. Placement of replacement valve 460 within apparatus 450 may be seen in FIG. 37B. The patient's native valve is captured between lip region 472 and skirt region 474 of anchor 470 in the fully deployed configuration (see FIG. 38B).

Referring to FIGS. 38A-C, in conjunction with FIGS. 35 and 36, a method for endovascularly replacing a patient's diseased aortic valve with apparatus 450 is described. Delivery system 410, having apparatus 450 disposed therein, is endovascularly advanced, preferably in a retrograde fashion, through a patient's aorta A to the patient's diseased aortic valve AV. Sheath 420 is positioned such that its distal end is

disposed within left ventricle LV of the patient's heart H. As described with respect to FIG. 35, apparatus 450 is deployed from lumen 422 of sheath 420, for example, under fluoroscopic guidance, such that skirt section 474 is disposed within left ventricle LV, body section 476b is disposed across the patient's native valve leaflets L, and lip section 472 is disposed within the patient's aorta A. Advantageously, apparatus 450 may be dynamically repositioned to obtain proper alignment with the anatomical landmarks. Furthermore, apparatus 450 may be retracted within lumen 422 of sheath 420 via wires 424, even after anchor 470 has dynamically expanded to the partially deployed configuration, for example, to abort the procedure or to reposition sheath 420.

Once properly positioned, wires 424a are retracted to expand skirt region 474 of anchor 470 within left ventricle LV. Skirt region 474 is locked in the expanded configuration via skirt lock 490, as previously described with respect to FIG. 36. In FIG. 38A, skirt region 474 is maneuvered such that it engages the patient's valve annulus An and/or native valve leaflets L, thereby providing positive registration of apparatus 450 relative to the anatomical landmarks.

Wires 424b are then actuated external to the patient in order to expand lip region 472, as previously described in FIG. 35. Lip region 472 is locked in the expanded configuration via lip lock 480. Advantageously, deployment of apparatus 450 is fully reversible until lip lock 480 and/or skirt lock 490 has been actuated. Wires 424 are pulled from eyelets 483 and 493, and delivery system 410 is removed from the patient. As will be apparent, the order of expansion of lip region 472 and skirt region 474 may be reversed, concurrent, etc.

As seen in FIG. 38B, lip region 472 engages the patient's native valve leaflets L, thereby providing additional positive registration and reducing a risk of lip region 472 blocking the patient's coronary ostia O. FIG. 38C illustrates the same in cross-sectional view, while also showing the position of replacement valve 460. The patient's native leaflets are engaged and/or captured between lip region 472 and skirt region 474. Advantageously, lip region 472 precludes distal migration of apparatus 450, while skirt region 474 precludes proximal migration. It is expected that lip region 472 and skirt region 474 also will reduce paravalvular regurgitation.

Referring now to FIG. 39, an embodiment of apparatus in accordance with the present invention is described, wherein the replacement valve is not connected to the expandable portion of the anchor. Rather, the replacement valve is wrapped about an end of the anchor. Such wrapping may be achieved, for example, by everting the valve during endovascular deployment.

In FIG. 39, apparatus 500 comprises expandable anchor 30' and everting replacement valve 520, as well as delivery system 100' for endoluminally delivering and deploying the expandable anchor and everting valve. Expandable anchor 30' illustratively is described as substantially the same as previously described anchor 30 of FIGS. 1-4; however, it should be understood that anchor 30' alternatively may be substantially the same as anchor 300 of FIGS. 17 and 18, anchor 350 of FIGS. 24-26, or anchor 470 of FIG. 35. As with anchor 30, anchor 30' comprises posts 38 and locks (comprised of elements 523 and 532). Alternative locks may be provided, such as locks 40', 40'', 40''' or 40'''' of FIGS. 11 and 12, or the reversible lock of anchor 300 described with respect to FIGS. 17 and 18.

Everting valve 520 is similar to previously described valve 20, in that commissures 524 of replacement valve leaflets 526 are coupled to and supported by posts 38 of anchor 30'. However, annular base 522 of replacement valve 520 is not coupled to anchor 30'. Rather, annular base 522 is coupled to

17

everting segment 528 of everting replacement valve 520. Everting segment 528 is disposed distal of anchor 30' in the delivery configuration and is configured to wrap about the distal end of the anchor during deployment, such as by everting, thereby holding (such as by friction locking) replacement valve 520 between the anchor and the patient's tissue, thereby creating a seal between the anchor and the patient's tissue. In this manner, replacement valve 520 is entirely disconnected from the expandable/collapsible portion of anchor 30', and a delivery profile of apparatus 500 is reduced, as compared to previously described apparatus 10.

Everting segment 528 of valve 520 may be fabricated from the same material as valve leaflets 526, e.g., a biologic tissue or a polymeric material. Alternatively, the segment may comprise a fabric, such as a permeable or impermeable fabric, a fabric that promotes or retards tissue ingrowth, a sealing foam, etc. Additional materials will be apparent.

Delivery system 100' for use with anchor 30' and replacement valve 520, is similar to previously described delivery system 100. The delivery system comprises sheath 110' having lumen 112', in which anchor 30' may be collapsed for delivery. Control wires 50, tubes 60 and control wires 62 have been provided to deploy, foreshorten, retrieve, etc., anchor 30', as discussed previously, and optional balloon catheter 360 has been provided as a collapsible nosecone (see FIG. 25). In delivery system 100', the posts are connected to the distal end of the anchor and the everting valve is connected to the posts. Delivery system 100' differs from system 100 in that it further comprises eversion control wires 550, which may, for example, be fabricated from suture.

Control wires 550 are coupled to a distal region of everting segment 528 of valve 520, and then pass proximally out of the patient external to anchor 30' for manipulation by a medical practitioner. Control wires 550 preferably are kept taut to keep everting segment 528 in tension. Upon retraction of sheath 110' relative to anchor 30' and valve 520 (or advancement of the anchor and valve relative to the sheath), the tension applied to segment 528 by wires 550 causes the segment to evert and wrap about the distal end of anchor 30'. Anchor 30' then may be expanded and deployed as described previously, thereby friction locking everting segment 528 between the anchor and the patient's anatomy.

FIG. 39 illustrate a device and method for endovascularly replacing a patient's diseased aortic valve utilizing apparatus 500. In FIG. 39A, sheath 110' of delivery system 100', having expandable anchor 30' and everting valve 520 disposed therein within lumen 112', is endovascularly advanced over guide wire G, preferably in a retrograde fashion (although an antegrade or hybrid approach alternatively may be used), through a patient's aorta A to the patient's diseased aortic valve AV. Balloon catheter nosecone 360 precedes sheath 110'. Sheath 110' is positioned such that its distal region is disposed within left ventricle LV of the patient's heart H. In FIG. 39A, wires 550 pass from segment 528 and lumen 112' to the exterior of sheath 110' via through-holes 111a', and then more proximally pass back into the interior of sheath 110' via through-holes 111b', which are disposed proximal of anchor 30'.

FIG. 39B is a blow-up of the intersection of tubes 60, wires 62 and anchor 30'.

FIG. 39C illustrates the beginning of the everting process wherein everting segment 528 is being pulled proximally over the exterior of anchor 30'. As seen in FIG. 39C, which provides and isometric view of the device, the inflatable element of balloon catheter 360 is deflated and further distally advanced within left ventricle LV along guide wire G relative to sheath 110'. Anchor 30' and replacement valve 520 then are

18

advanced relative to the sheath via tubes 60 and control wires 62, thereby deploying everting segment 528 of valve 520, as well as a distal region of anchor 30', from the distal end of lumen 112'. Tension applied to everting segment 528 via control wires 550 connected through eyelets 529 causes the segment to wrap about the distal region of anchor 30' by everting.

In FIG. 39C, wires 550 may pass distally from everting segment 528 out the distal end of lumen 112' of sheath 110', then proximally along the interior surface of the sheath all the way out of the patient. Optional through-holes 111b' allow wires 550 to be disposed within lumen 112' along a majority of their length. Wires 550 may also pass back into multi-lumen sheath 180.

FIG. 39D provides a cross sectional view of apparatus 500 after replacement valve 520 has everted about anchor 30'. This and other cross sectional figures portray a 120° view of the apparatus herein. Sheath 10' is then retracted relative to anchor 30' and valve 520, which deploys a remainder of the anchor and the replacement valve from lumen 112' of the sheath. Such deployment may be conducted, for example, under fluoroscopic guidance. Anchor 30' dynamically self-expands to a partially deployed configuration.

Advantageously, anchor 30' and replacement valve 520 may be retrieved and retracted within the lumen of sheath 110' via retraction of multi-lumen catheter 180 to which tubes 60 are attached and release of wires 50. Such retrieval of apparatus 500 may be achieved even after segment 528 has been wrapped about anchor 30', and even after anchor 30' has dynamically expanded to the partially deployed configuration. Retrieval of apparatus 500 may be utilized, for example, to abort the procedure or to reposition the apparatus. As yet another advantage, anchor 30' and valve 520 may be dynamically repositioned, e.g. via proximal retraction of multi-lumen catheter 180 and/or release of wires 50, in order to properly align the apparatus relative to anatomical landmarks, such as the patient's coronary ostia O or the patient's native valve leaflets L.

Once properly aligned sheath 110', tubes 60 and wires 62 are advanced relative to wires 50 and 550 to impose foreshortening upon anchor 30', thereby expanding the anchor to the fully deployed configuration, as in FIG. 39G. Foreshortening friction locks everting segment 528 of valve 520 between anchor 30' and annulus An/leaflets L of the patient's diseased valve, thus properly seating the valve within the anchor while providing an improved seal between the replacement and native valves that is expected to reduce paravalvular regurgitation. Foreshortening also increases a radial strength of anchor 30', which is expected to prolong patency of valve annulus An. Furthermore, foreshortening actuates the anchor's locks, which maintain such imposed foreshortening.

Deployment of anchor 30' and replacement valve 520 advantageously is fully reversible until the anchor locks have been actuated. Furthermore, if the anchor's locks are reversible locks or buckles, such as those described in conjunction with anchor 300 of FIGS. 17 and 18, deployment of the anchor and valve may be fully reversible even after actuation of the locks/buckles, right up until delivery system 100' is decoupled from the replacement apparatus.

As seen in FIG. 39G, in order to complete deployment of anchor 30' and replacement valve 520, wires 50 of delivery system 100' are decoupled from posts 38 of anchor 30', tubes 60 are decoupled from anchor 30', e.g. via wires 62, and wires 550 are decoupled from friction-locked everting segment 528 of replacement valve 520. FIG. 39E illustrates how wires 50 are associated with posts 38. In one example, wires 50 are decoupled from posts 38 by pulling on one of the wires.

19

Decoupling of the wires and tubes may also be achieved, for example, via eyelets (see FIGS. 4E, 19-21 and 39E) or via cutting of the wires. Delivery system 100' then is removed from the patient, as are deflated balloon catheter 360 and guide wire G, both of which are retracted proximally across the replacement valve and anchor. Normal blood flow between left ventricle LV and aorta A thereafter is regulated by replacement valve 520. FIG. 39F is a blow up illustration of replacement valves 526 which are connected to everting segment 528, wherein everting segment 528 has been everted around anchor 30'.

Referring now to FIG. 40, an alternative embodiment of everting apparatus in accordance with the present invention is described, wherein the posts are connected and the everting valve is disposed within the anchor to the proximal end of the anchor in the delivery configuration. In FIG. 40, apparatus 600 comprises everting replacement valve 620 and anchor 630, as well as previously described delivery system 100'. Replacement valve 620 and anchor 630 are substantially the same as valve 520 and anchor 30' of FIG. 39, except that valve 620 is initially seated more proximally within anchor 630, such that everting segment 628 of valve 620 is initially disposed within the anchor. Locking mechanisms as described previously may be implemented at the distal end of the post and anchor or proximal end of everted segment and anchor.

As with replacement valve 520, everting segment 628 of valve 620 is configured to wrap about the distal end of anchor 630 by everting during deployment, thereby friction locking the replacement valve between the anchor and the patient's anatomy. Furthermore, replacement valve 620 is entirely disconnected from the expandable/collapsible portion of anchor 630. In the delivery configuration, since only a single circumferential layer of valve 620 is present along any cross section of apparatus 600, a delivery profile of the apparatus is reduced, as compared to previously described apparatus 10. With apparatus 10, two circumferential layers of valve 20 are present in the cross section where annular base 22 of the valve is coupled to the expandable anchor 30.

FIG. 40 illustrate a method of endovascularly replacing a patient's diseased aortic valve utilizing apparatus 600. In FIG. 40A, apparatus 600 is endovascularly advanced into position with valve 620 and anchor 630 disposed within lumen 112' of sheath 110' of delivery system 100'. As seen in FIG. 40B, the valve and anchor are advanced relative to the sheath and/or the sheath is retracted relative to the valve and anchor, which deploys everting segment 628 of the valve, as well as a distal region of the anchor. Tension applied to the everting segment via control wires 550 causes the segment to evert and wrap about the distal region of anchor 630. Control wires 550 may enter the multi-lumen catheter at the distal end of the catheter or more proximally as is illustrated in 40C. Further retraction of sheath 110' deploys a remainder of replacement valve 620 and anchor 630 from lumen 112' of the sheath. Such deployment may be conducted, for example, under fluoroscopic guidance. Anchor 630 dynamically self-expands to a partially deployed configuration.

Once the anchor and valve have been properly aligned in relation to anatomical landmarks, foreshortening is imposed upon anchor 630 to expand the anchor to the fully deployed configuration, as in FIG. 40C. At this point, Locks may be actuated as previously described. Foreshortening friction locks everting segment 628 of valve 620 between anchor 630 and annulus An/leaflets L of the patient's diseased valve, thus properly seating the valve within the anchor while providing an improved seal between the replacement and native valves. Foreshortening also increases a radial strength of anchor 630, which is expected to prolong patency of valve annulus An. Deployed valve 620 and anchor 630 then are decoupled from delivery system 100', as in FIG. 40D, thereby completing

20

deployment of apparatus 600. Thereafter, normal blood flow between left ventricle LV and aorta A is regulated by replacement valve 620.

As with apparatus 500, apparatus 600 may be dynamically repositioned during deployment, for example, in order to properly align the apparatus relative to anatomical landmarks. Furthermore, apparatus 600 advantageously may be retrieved at any point at least up until actuation of optimal locks maintaining foreshortening. When the optional locks are reversible, retrieval may be achieved until valve 620 and anchor 630 are separated from delivery system 100'.

FIG. 41 illustrate an alternative embodiment of the present invention wherein the everting valve is distal to the anchor and the posts are not connected to the braid in the delivery configuration. As is illustrated in FIG. 41A, apparatus 700 comprises everting valve 720 and expandable anchor 730, as well as delivery system 750. Delivery system 750 includes multi-lumen catheter 180. Anchor 730 is fabricated from an expandable braid and comprises female/male element 732 of a locking mechanism, which is preferably reversible. Everting valve 720 comprises valve leaflets 726 and everting segment 728. Everting valve 720 further comprises posts 722 to which valve leaflets 726 are attached to provide commissure support. Posts 722, which are non-expandable and non-collapsible, comprise opposite male/female elements 723 of locking mechanism comprising eyelets. In the delivery configuration of FIG. 41A, anchor 730 may extend distally far enough to just overlap the proximal-most section of valve 720.

Delivery system 750 is similar to previously described delivery system 100' and includes multi-lumen catheter 180. As with previous embodiments, delivery system 750 facilitates dynamic repositioning and/or retrieval of apparatus 700 after partial or full deployment of the apparatus, e.g., right up until the apparatus is separated from the delivery system.

As seen in FIG. 41A, wires 50 pass from the multi-lumen catheter 180 through the female/male locking mechanism 732, which is associated with anchor 730. Wires 50 then further pass through female/male locking mechanism 723, which is at the proximal end of posts 722. Preferably, a double strand of each wire 50 is provided to facilitate decoupling of wires 50 from valve 720 and anchor 730 in the manner described previously. When wires 50 are pulled proximally into the multi lumen catheter 180, posts 722 move proximally within anchor 730, and the female/male element 723 interacts with female/male element 732 of anchor 730. In this embodiment, when element 723 is male, then element 732 is female, and vice versa.

Thus, valve 720 and anchor 730 are entirely decoupled from one another in the delivery configuration. Wires 50 are configured to approximate the telescoped valve and anchor, as well as to actuate locking mechanism 740 and contribute to foreshortening of anchor 730. By separating valve 720 and anchor 730 within lumen 112' of sheath 110', a delivery profile of apparatus 700 may be reduced.

In FIG. 41A, apparatus 700 is endovascularly advanced into position with valve 720 and anchor 730 spaced from one another within lumen 112' of sheath 110' of delivery system 750. Substantially all of valve 720 and its supporting posts 722 are disposed distal to the anchor during delivery. As seen in FIG. 41B, to evert valve 720, sheath 110' is pulled proximally around anchor 730.

Next, in FIG. 41C, to approximate anchor 730 and valve 720, the elongated braid of anchor 730 is pushed distally to the base of posts 722 using tubes 60 maintained in association with anchor 730 by wire 62. Anchor 730 will engage with the distal end of posts 722—an anchor engagement feature 729. In some embodiments, as illustrated in FIG. 41C, wires 550 re-enter sheath 110' proximal to the distal end of the multi-lumen catheter 180.

In FIG. 41D, the multi-lumen catheter 180 is held steady, while wires 50 are pulled proximally. This allows the foreshortening of anchor 730 and the engagement of the male and female elements of locking mechanism of 740. Foreshortening friction locks segment 728 of valve 720 against valve annulus An/leaflets L, thereby properly seating the valve within anchor 730. Foreshortening also completes expansion of anchor 730 and actuates locking mechanism 740, which maintains such expansion of the anchor. Delivery system 750 then may be decoupled from valve 720 and anchor 730, thereby completing deployment of apparatus 700. Normal blood flow between left ventricle LV and aorta A thereafter is regulated by replacement valve 720.

With reference now to FIG. 42, yet another alternative embodiment of everting apparatus in accordance with the present invention is described, wherein the replacement valve leaflets evert and wrap about the distal region of the anchor. Apparatus 800 comprises everting replacement valve 820 and expandable anchor 830. Valve 820 comprises posts 822, to which valve leaflets 826 are attached. The valve further comprises everting segment 828. Proximal regions 823 of posts 822 are rotatably coupled to a distal region of anchor 830, while distal regions 824 of the posts are coupled to control wires 50.

In the delivery configuration of FIG. 42A, posts 822 (and, thus, valve leaflets 826) and everting segment 828 of replacement valve 820 are disposed distal of anchor 830. FIG. 42B illustrates deployment of apparatus 800, whereby tubes 60/wires 62 (see, e.g., FIG. 41) are actuated in conjunction with control wires 50 to actively foreshorten anchor 830 and rotate posts 822 into position within the lumen of anchor 830, thereby everting valve leaflets 826 into position within the anchor. Furthermore, eversion wires 550 are actuated to evert segment 828 and wrap the segment about the exterior of anchor 830. Locks 840 maintain expansion and foreshortening of anchor 830.

Referring to FIG. 43, an everting embodiment of the present invention is described wherein a portion of the locking mechanism configured to maintain expansion of the anchor is coupled to the everting segment of the replacement valve instead of, or in addition to, the anchor posts and anchor posts P are only loosely associated with the anchor 930. Apparatus 900 comprises replacement valve 920 and anchor 930. Everting segment 928 of the replacement valve comprises male elements 942 of locks 940, while anchor 930 comprises female elements 944 of locks 940. Upon deployment of apparatus 900 from the delivery configuration of FIG. 43A to the deployed configuration of FIG. 43B, segment 928 of replacement valve 920 everts to wrap about the exterior of anchor 930, which is actively foreshortened during expansion. Locks 940 maintain anchor expansion.

With reference to FIG. 44, another telescoping embodiment of the present invention is described wherein the replacement valve comprises a U-shaped frame configured to receive the anchor. Optionally, the valve may comprise an everting segment that everts about the frame and/or the anchor during deployment. Apparatus 1000 comprises replacement valve 1020 and expandable anchor 1030. Replacement valve 1020 comprises frame 1022, leaflets 1026 and optional everting segment 1028.

Valve 1020 and anchor 1030 are configured for relative movement, such that the valve and anchor may be telescoped and spaced apart during delivery, thereby reducing a delivery profile of apparatus 1000, but may be approximated during deployment. Everting segment 1028 of valve 1020 optionally

may be disposed distal of valve frame 1022 during delivery, thereby further reducing a delivery profile of apparatus 1000, then everted during deployment.

As seen in FIG. 44A, the U-shape of valve frame 1022 preferably tilts leaflets 1026 of replacement valve 1020 slightly inward relative to blood flow through apparatus 1000. As seen in FIG. 44B, valve frame 1022 optionally may comprise a symmetric U-shape, which captures anchor 1030 on both sides in the deployed configuration. Frame 1022 may comprise lock 1040 that closes the frame's U-shape into an elliptical shape in the deployed configuration, thereby maintaining expansion of anchor 1030.

Prior to implantation of one of the replacement valves described above, it may be desirable to perform a valvuloplasty on the diseased valve by inserting a balloon into the valve and expanding it using saline mixed with a contrast agent. In addition to preparing the valve site for implant, fluoroscopic viewing of the valvuloplasty will help determine the appropriate size of replacement valve implant to use.

What is claimed is:

1. A system for replacing a heart valve, comprising:
  - an expandable anchor having a collapsed delivery configuration and an expanded configuration, the expandable anchor comprising a distal end;
  - a replacement valve commissure support element attached to the expandable anchor;
  - a commissure portion of a replacement valve leaflet attached to the commissure support element; and
  - a fabric seal at least partially disposed around an exterior portion of the expandable anchor when the anchor is in the expanded configuration, the fabric seal having an undeployed state and a deployed state, wherein in the deployed state the fabric seal comprises flaps that extend into spaces formed by native valve leaflets;
- wherein a distal end of the replacement valve leaflet is attached to the fabric seal and when the expandable anchor is in the collapsed delivery configuration, the fabric seal extends from the distal end of the replacement valve and back proximally over the expandable anchor, the fabric seal being adapted to prevent blood from flowing between the fabric seal and heart tissue.
2. The system of claim 1, wherein, in the deployed state, the fabric seal defines a plurality of pockets.
3. The system of claim 2, wherein the pockets are adapted to fill with blood in response to backflow blood pressure.
4. The system of claim 1, wherein the expandable anchor is formed from stainless steel or nickel-titanium alloy.
5. The system of claim 1, wherein the commissure support element is configured to interface with an anchor actuator.
6. The system of claim 5, wherein the anchor actuator is adapted to apply a proximally directed force on the commissure support element to foreshorten the expandable anchor.
7. The system of claim 1 further comprising a lock having a first lock element and a second lock element, the first and second lock elements being attached to the expandable anchor and configured to interlockingly engage one another to lock the expandable anchor in the expanded configuration.
8. The system of claim 7, wherein the commissure support element includes the first lock element.
9. The system of claim 8, wherein the second lock element is attached to the expandable anchor and is disposed proximal to the first lock element when the expandable anchor is in the collapsed delivery configuration.

\* \* \* \* \*