



US005140199A

# United States Patent [19]

[11] Patent Number: **5,140,199**

Seo

[45] Date of Patent: **Aug. 18, 1992**

[54] **SENSE AMPLIFIER DRIVER FOR MEMORY DEVICE HAVING REDUCED POWER DISSIPATION**

0178796 8/1986 Japan ..... 365/205  
0226111 9/1988 Japan ..... 307/603  
0275223 11/1988 Japan ..... 307/481

[75] Inventor: **Seung-mo Seo, Seoul, Rep. of Korea**

### OTHER PUBLICATIONS

[73] Assignee: **Samsung Electronics Co., Ltd., Rep. of Korea**

IBM Tech. Disc. Bult.; Chakravarti et al.; High Gain Sense Amplifier; Dec. 1977; p. 206.  
Wong et al.; Memory Techniques—A 45ns Fully Static 16K MOS ROM; Feb. 19, 1981; p. 150.

[21] Appl. No.: **358,679**

[22] Filed: **May 30, 1989**

*Primary Examiner*—Stanley D. Miller  
*Assistant Examiner*—Terry D. Cunningham  
*Attorney, Agent, or Firm*—Morgan & Finnegan

### [30] Foreign Application Priority Data

Jul. 11, 1988 [KR] Rep. of Korea ..... 88-8607

[51] Int. Cl.<sup>5</sup> ..... **G11C 7/00**

[52] U.S. Cl. .... **307/530; 307/263; 307/592; 307/601; 365/205; 365/233**

[58] Field of Search ..... 307/263, 530, 592, 601, 307/603, 481; 365/194, 205, 233

### [56] References Cited

#### U.S. PATENT DOCUMENTS

3,943,496	3/1976	Padgett et al.	365/233
4,295,062	10/1981	Mihalich et al.	307/290
4,508,978	4/1985	Reddy	307/482
4,638,187	1/1987	Boler et al.	307/270
4,649,295	3/1987	McLaughlin et al.	307/446
4,707,626	11/1987	Inoue	307/451
4,749,882	6/1988	Morgan	307/451
4,771,195	9/1988	Stein	307/451
4,829,199	5/1989	Prater	307/451
4,855,623	8/1989	Flaherty	307/451

#### FOREIGN PATENT DOCUMENTS

0156226	9/1983	Japan	307/605
0070592	4/1985	Japan	365/233

### [57] ABSTRACT

An improved sense amplifier driver for sensing and restoring data in memory cells is disclosed. Pull-up means in the form of p-channel MOS transistors are respectively provided for forcibly pulling up the gate voltage of delayable p-channel MOS transistors within the first inverter of the sensing clock driver and the second inverter of the restore clock driver in the trailing transient periods of the sensing and restoring clock signals. The formation of a DC current path between the power line and the ground line in any one of the delayable p-channel MOS transistors is prevented, thereby making it possible to avoid the unnecessary power dissipation. Further, delaying resistances are installed respectively in the first inverter of the sensing clock driver and in the second inverter of the restoring clock driver to make the slope of the leading edges of the sensing and restoring clocks less steep, thereby making it possible to exclude the occurrence of noise.

3 Claims, 5 Drawing Sheets

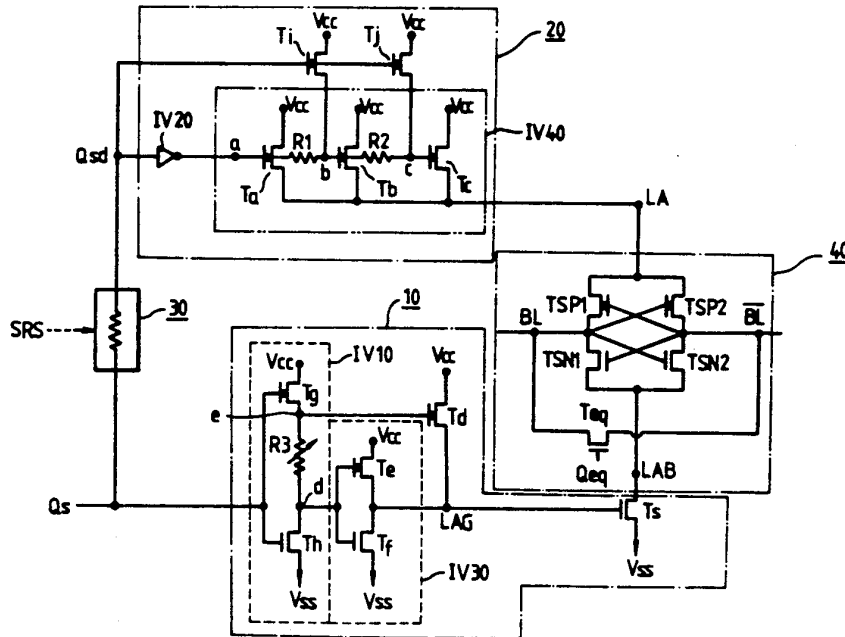



FIG. 2 (Prior Art)

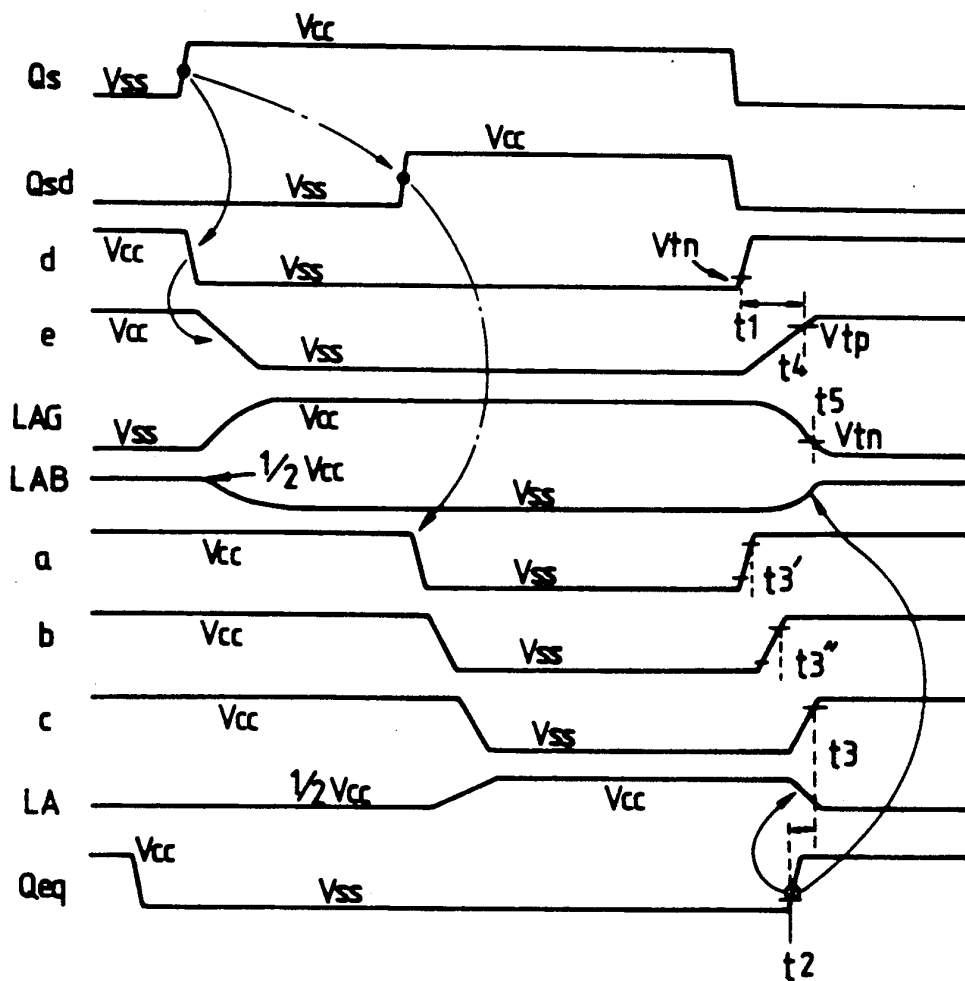

FIG. 3 (Prior Art)

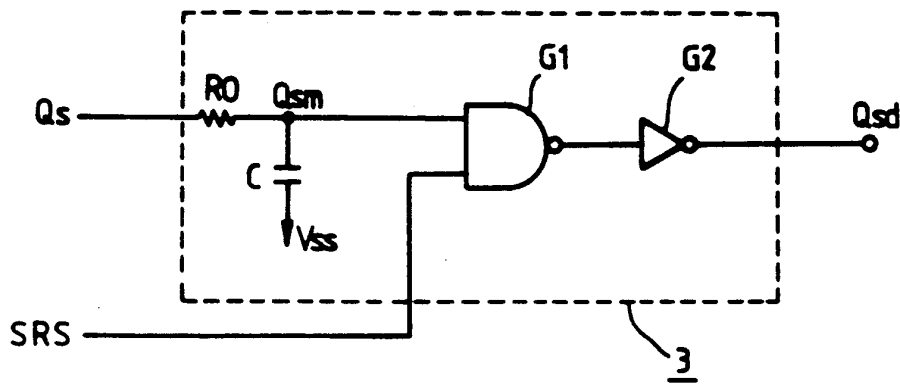
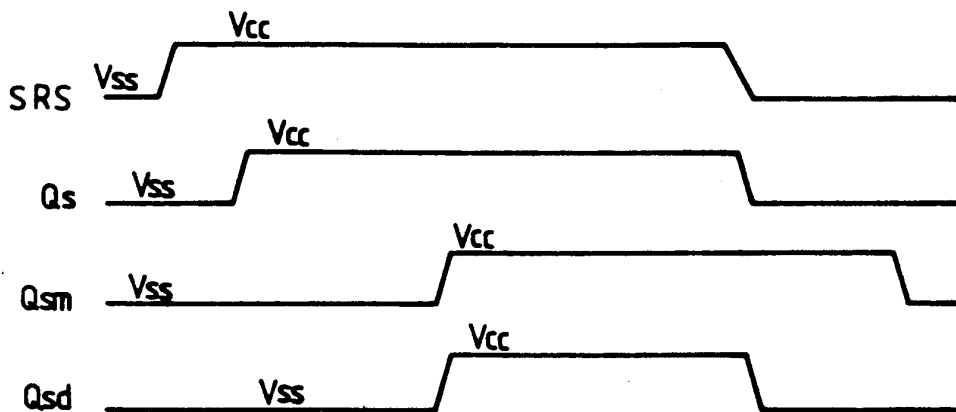
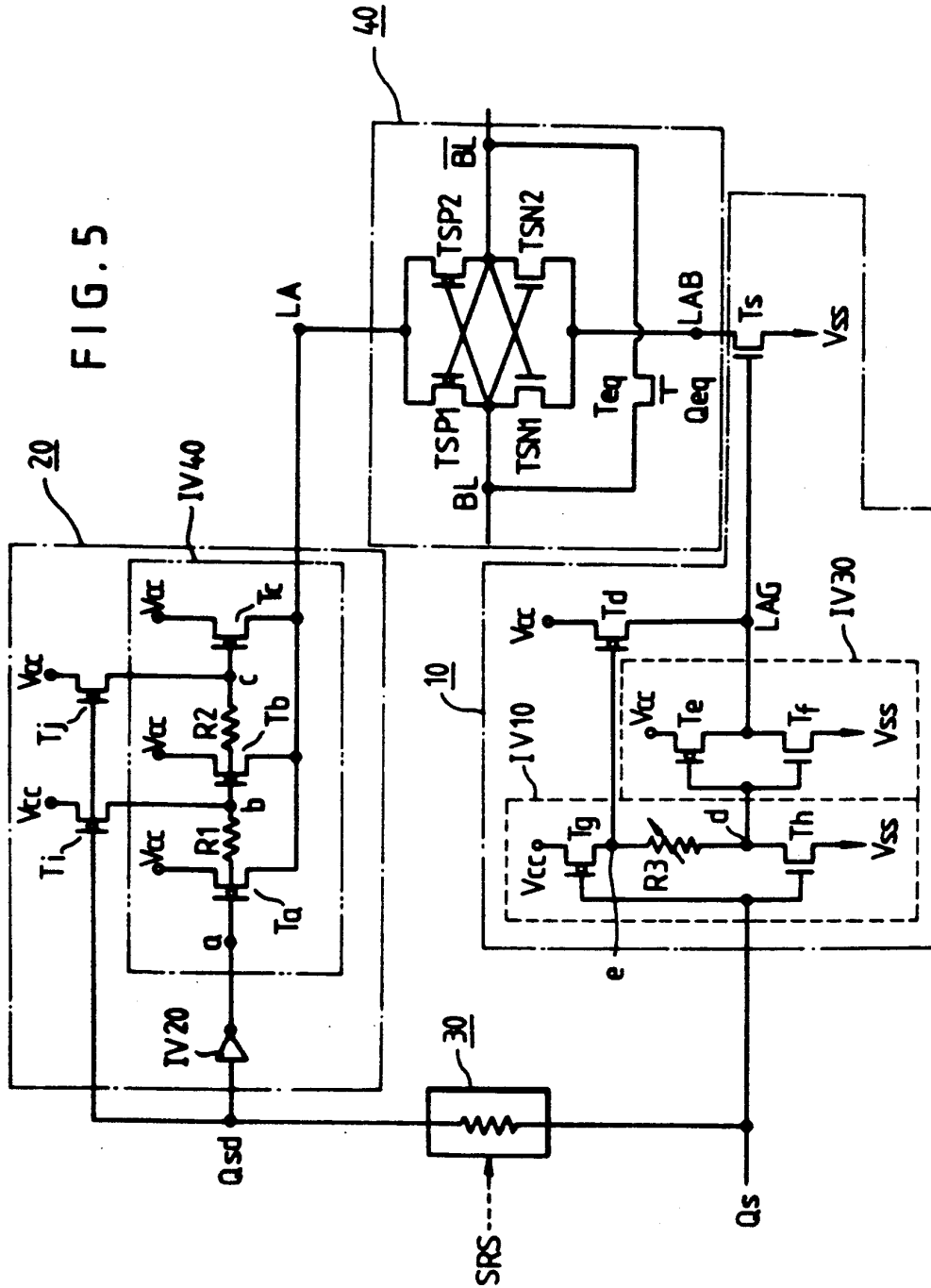

FIG. 4 (Prior Art)





# Explore Litigation Insights

Docket Alarm provides insights to develop a more informed litigation strategy and the peace of mind of knowing you're on top of things.

## Real-Time Litigation Alerts



Keep your litigation team up-to-date with **real-time alerts** and advanced team management tools built for the enterprise, all while greatly reducing PACER spend.

Our comprehensive service means we can handle Federal, State, and Administrative courts across the country.

## Advanced Docket Research



With over 230 million records, Docket Alarm's cloud-native docket research platform finds what other services can't. Coverage includes Federal, State, plus PTAB, TTAB, ITC and NLRB decisions, all in one place.

Identify arguments that have been successful in the past with full text, pinpoint searching. Link to case law cited within any court document via Fastcase.

## Analytics At Your Fingertips



Learn what happened the last time a particular judge, opposing counsel or company faced cases similar to yours.

Advanced out-of-the-box PTAB and TTAB analytics are always at your fingertips.

## API

Docket Alarm offers a powerful API (application programming interface) to developers that want to integrate case filings into their apps.

## LAW FIRMS

Build custom dashboards for your attorneys and clients with live data direct from the court.

Automate many repetitive legal tasks like conflict checks, document management, and marketing.

## FINANCIAL INSTITUTIONS

Litigation and bankruptcy checks for companies and debtors.

## E-DISCOVERY AND LEGAL VENDORS

Sync your system to PACER to automate legal marketing.