



US005442704A

United States Patent [19]

[11] Patent Number: 5,442,704

Holtey

[45] Date of Patent: Aug. 15, 1995

[54] SECURE MEMORY CARD WITH PROGRAMMED CONTROLLED SECURITY ACCESS CONTROL

[75] Inventor: Thomas O. Holtey, Newton, Mass.

[73] Assignee: Bull NH Information Systems Inc., Billerica, Mass.

[21] Appl. No.: 181,691

[22] Filed: Jan. 14, 1994

[51] Int. Cl.⁶ H04L 9/32; G07F 7/08

[52] U.S. Cl. 380/23; 235/380

[58] Field of Search 380/23, 24, 25; 235/380, 382

[56] References Cited

U.S. PATENT DOCUMENTS

4,819,204	4/1989	Schrenk	235/380 X
4,882,474	11/1989	Anderl et al.	235/380
4,885,788	12/1989	Takaragi et al.	235/380 X
5,285,200	2/1994	Kuriyama	235/380
5,313,520	5/1994	Han	380/23

Primary Examiner—Gilberto Barrón, Jr.

Attorney, Agent, or Firm—Faith F. Driscoll; John S. Solakian

single semiconductor chip which interconnects through an internal bus to a number of non-volatile addressable memory chips. The microprocessor includes an addressable non-volatile memory for storing information including a number of key values and program instruction information. Each chip's memory is organized into a number of blocks, each block including a number of rows of byte locations. Each row of each block further includes a lock bit location, the total number of which provide storage for a lock value uniquely coded to utilize a predetermined characteristic of the memory to ensure data protection. Each memory chip is constructed to include security control logic circuits which include a security access control unit and a volatile access control memory containing a plurality of access control storage elements. Under the control of a predetermined set of instructions, the security access control unit performs a predetermined key validation operation by comparing key values against the bit contents of lock bit locations read out a bit at a time during an authentication procedure with a host computer. After the successful performance of the key validation procedure, the microprocessor sets one of the storage elements of the volatile access control memory for enabling user access to block data.

[57] ABSTRACT

A secure memory card includes a microprocessor on a

20 Claims, 8 Drawing Sheets

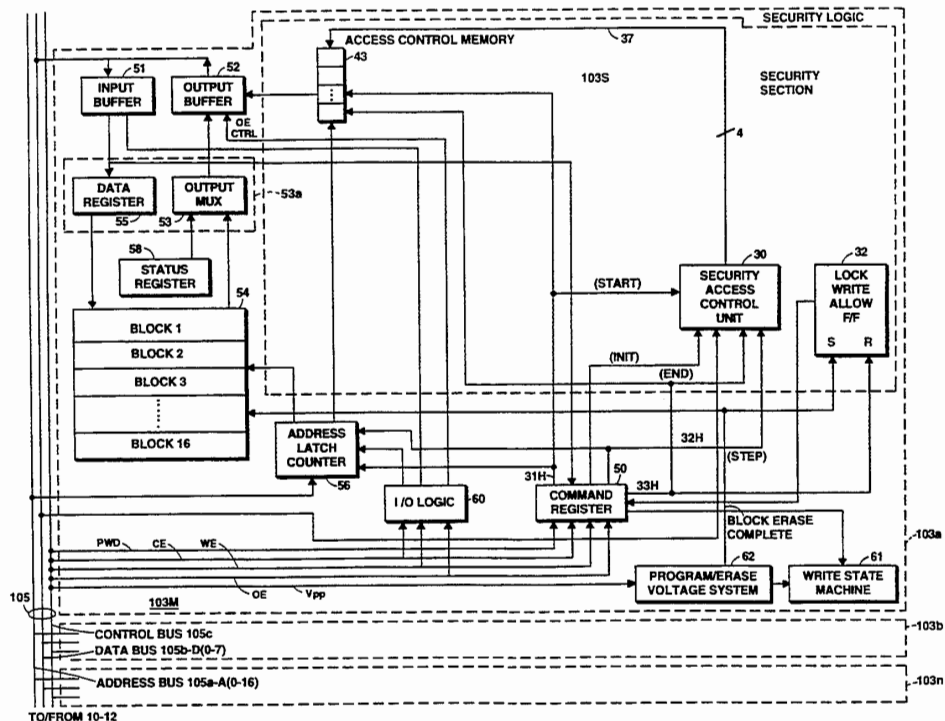
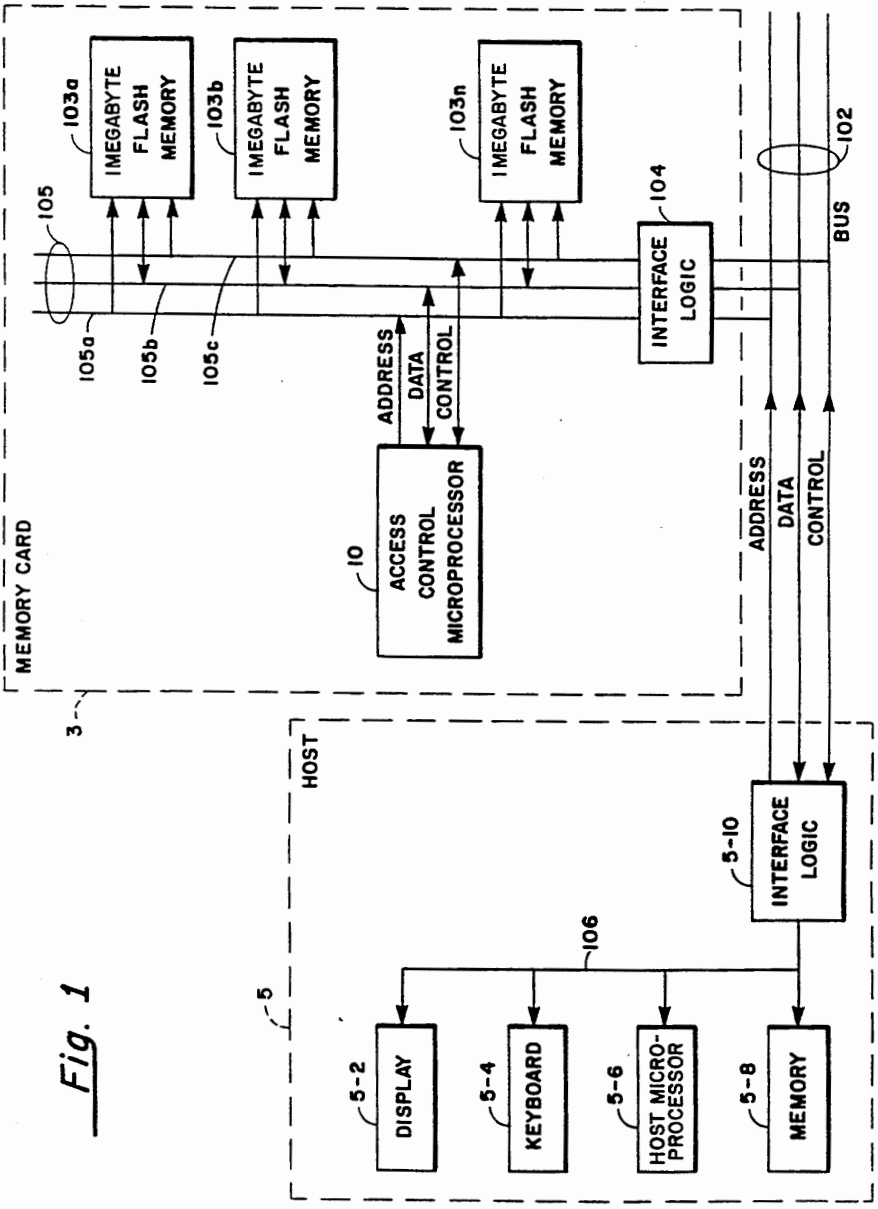

Fig. 1



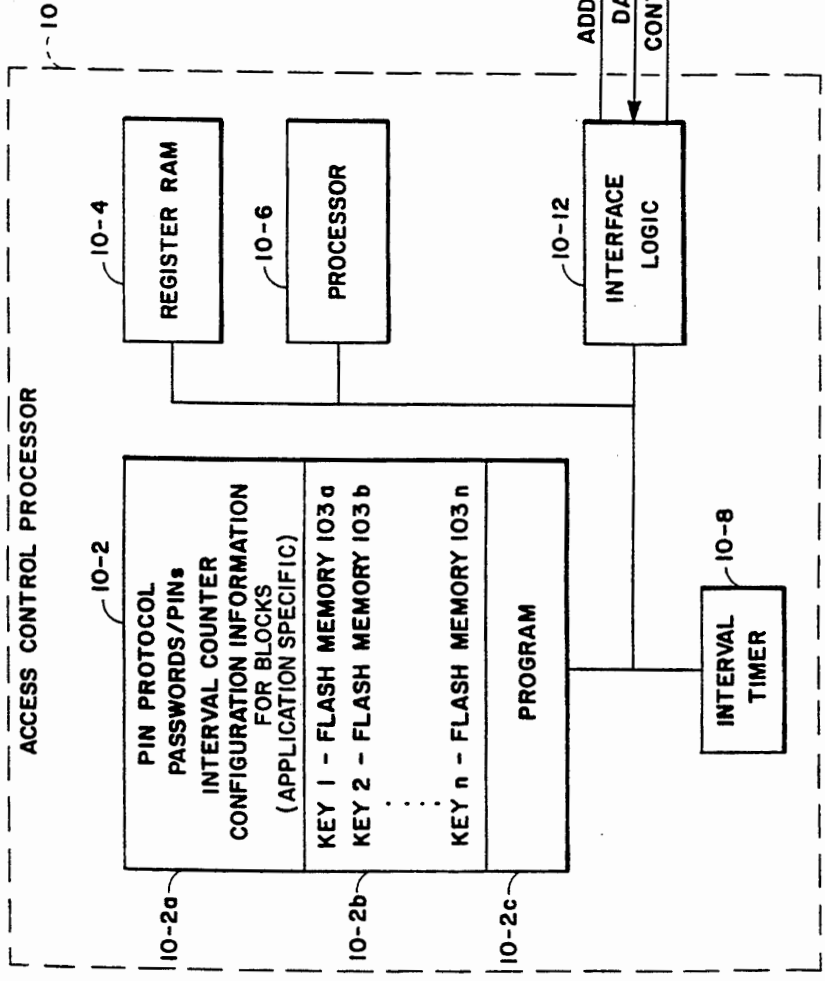
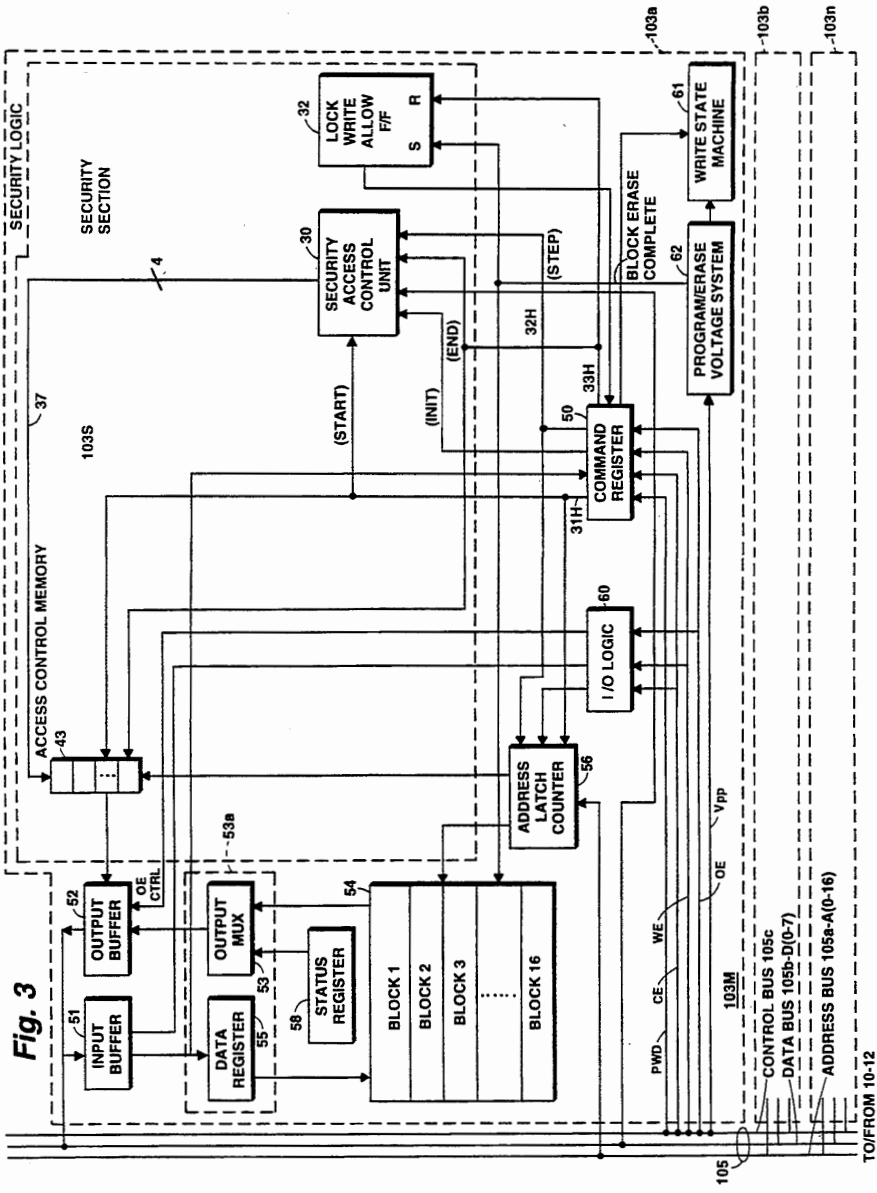

Fig. 2



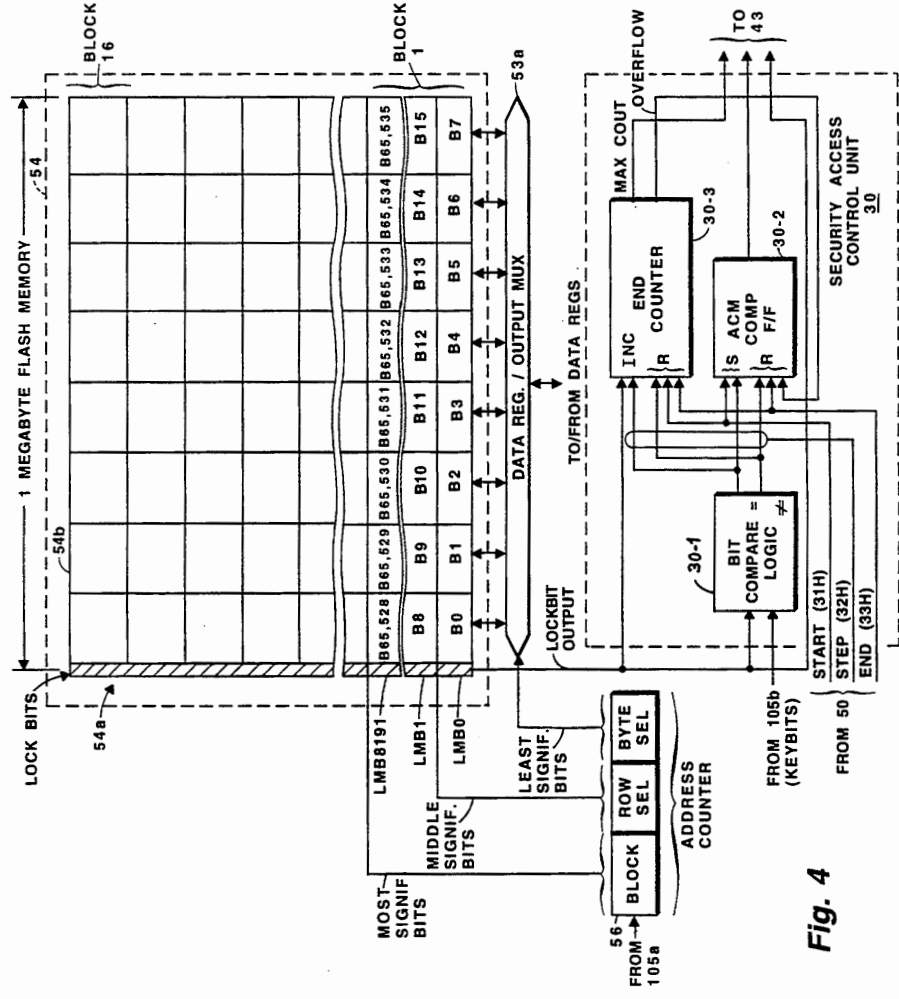

Fig. 4

Explore Litigation Insights

Docket Alarm provides insights to develop a more informed litigation strategy and the peace of mind of knowing you're on top of things.

Real-Time Litigation Alerts



Keep your litigation team up-to-date with **real-time alerts** and advanced team management tools built for the enterprise, all while greatly reducing PACER spend.

Our comprehensive service means we can handle Federal, State, and Administrative courts across the country.

Advanced Docket Research



With over 230 million records, Docket Alarm's cloud-native docket research platform finds what other services can't. Coverage includes Federal, State, plus PTAB, TTAB, ITC and NLRB decisions, all in one place.

Identify arguments that have been successful in the past with full text, pinpoint searching. Link to case law cited within any court document via Fastcase.

Analytics At Your Fingertips



Learn what happened the last time a particular judge, opposing counsel or company faced cases similar to yours.

Advanced out-of-the-box PTAB and TTAB analytics are always at your fingertips.

API

Docket Alarm offers a powerful API (application programming interface) to developers that want to integrate case filings into their apps.

LAW FIRMS

Build custom dashboards for your attorneys and clients with live data direct from the court.

Automate many repetitive legal tasks like conflict checks, document management, and marketing.

FINANCIAL INSTITUTIONS

Litigation and bankruptcy checks for companies and debtors.

E-DISCOVERY AND LEGAL VENDORS

Sync your system to PACER to automate legal marketing.