

UNITED STATES PATENT AND TRADEMARK OFFICE

---

BEFORE THE PATENT TRIAL AND APPEAL BOARD

---

ELEKTA, INC.  
Petitioner,

v.

VARIAN MEDICAL SYSTEMS, INC.,  
Patent Owner.

---

Case IPR2016-01904  
Patent 6,888,919 B2

---

Before BRIAN J. McNAMARA, PATRICK BOUCHER, and  
GARTH BAER, *Administrative Patent Judges*.

McNAMARA, *Administrative Patent Judge*.

DECISION  
Institution of *Inter Partes* Review  
*37 C.F.R. § 42.108*

## BACKGROUND

Elekta, Inc. (“Petitioner”) filed a petition, Paper 1 (“Pet.”), to institute an *inter partes* review of claims 1–4, 9, 11, and 13 (the “challenged claims”) of U.S. Patent No. 6,888,919 B2 (“the ’919 Patent”). 35 U.S.C. § 311. Varian Medical systems, Inc. (“Patent Owner”) timely filed a Preliminary Response, Paper 6 (“Prelim. Resp.”), contending that the Petition should be denied as to all challenged claims. We have jurisdiction under 37 C.F.R. § 42.4(a) and 35 U.S.C. § 314, which provides that an *inter partes* review may not be instituted unless the information presented in the Petition “shows that there is a reasonable likelihood that the petitioner would prevail with respect to at least 1 of the claims challenged in the petition.” Having considered the arguments and the associated evidence presented in the Petition and the Preliminary Response, for the reasons described below, we institute *inter partes* review of all the challenged claims (claims 1–4, 9, 11, and 13).

## REAL PARTIES IN INTEREST

Petitioner identifies itself and Elekta AB, Elekta Instrument AB, and Elekta Holdings U.S., Inc., as real parties-in-interest. Pet. 55.

## PENDING LITIGATION

The Petition states that Patent Owner asserted the ’919 Patent in *Varian Medical Systems, Inc. v. Elekta AB et al.*, No. 15-871-LPS, filed on September 25, 2015, and served on September 29, 2015. Pet. 55

THE '919 PATENT (EXHIBIT 1001)

The invention in the '919 Patent concerns an X-ray and electron radiotherapy machine for use in radiation treatment applications, e.g., oncology radiation therapy. Ex. 1001, 1:7–10. The '919 Patent states that, due to natural variations in the human body and changes in tumors during treatment, one challenge in radiotherapy is accurate positioning of the tumor in the radiation field. *Id.* 1:28–39. High energy megavolt radiation used for therapeutic treatment produces low contrast images that are used primarily for confirming the target volume has been radiated. *Id.* at 1:40–49. Low energy X-rays, typically 125 kV peak, are more useful for targeting or diagnostic information because they provide contrast that is far superior to that available in images generated from therapeutic megavolt electron beams. *Id.* at 1:49–64. A common treatment approach has been to use two separate imagers, each sensitive to an energy range, i.e., a low energy imager for diagnostic purposes and to provide accurate targeting and a high energy therapeutic imager to confirm the target has been radiated. *Id.* at 57–67. Figure 1A, labelled “Prior Art,” shows a radiotherapy machine with a therapeutic radiation source directed to a therapeutic imager and a single diagnostic radiation source directed to a diagnostic imager. *Id.* at 2:19–32. Figure 1B, also labelled “Prior Art,” shows a radiotherapy machine with a therapeutic radiation source capable of propagating high energy therapeutic energy to a therapeutic imager and, attached to support structures, two diagnostic radiation sources at off angles from the therapeutic radiation source, each in line with an imager to receive the radiation. *Id.* at 2:43–42. The entire structure of radiation sources and imagers can be pivoted together by a common base. *Id.* at 43–44. The '919 Patent notes that, because 360

degrees of rotation of the support structure holding the radiation source is required to radiate the target volume from different directions without turning the patient over, there is limited space for the various machine components. *Id.* at 2:44–61. The '919 Patent addresses the space limitations with a radiotherapy machine structure that uses a multiple-energy imager. *Id.* at 3:3–7; 11–14. None of the challenged claims, however, is limited to a multiple energy imager.

An annotated version of Figure 2A of the '919 Patent labelling the parts of a radiotherapy machine embodiment that has its therapeutic and diagnostic energy sources on separate C-shaped arms with one arm having a smaller radius of curvature nestled within the other arm is shown below. Ex. 1001, Fig. 2A; 5:12–14; 43–46.

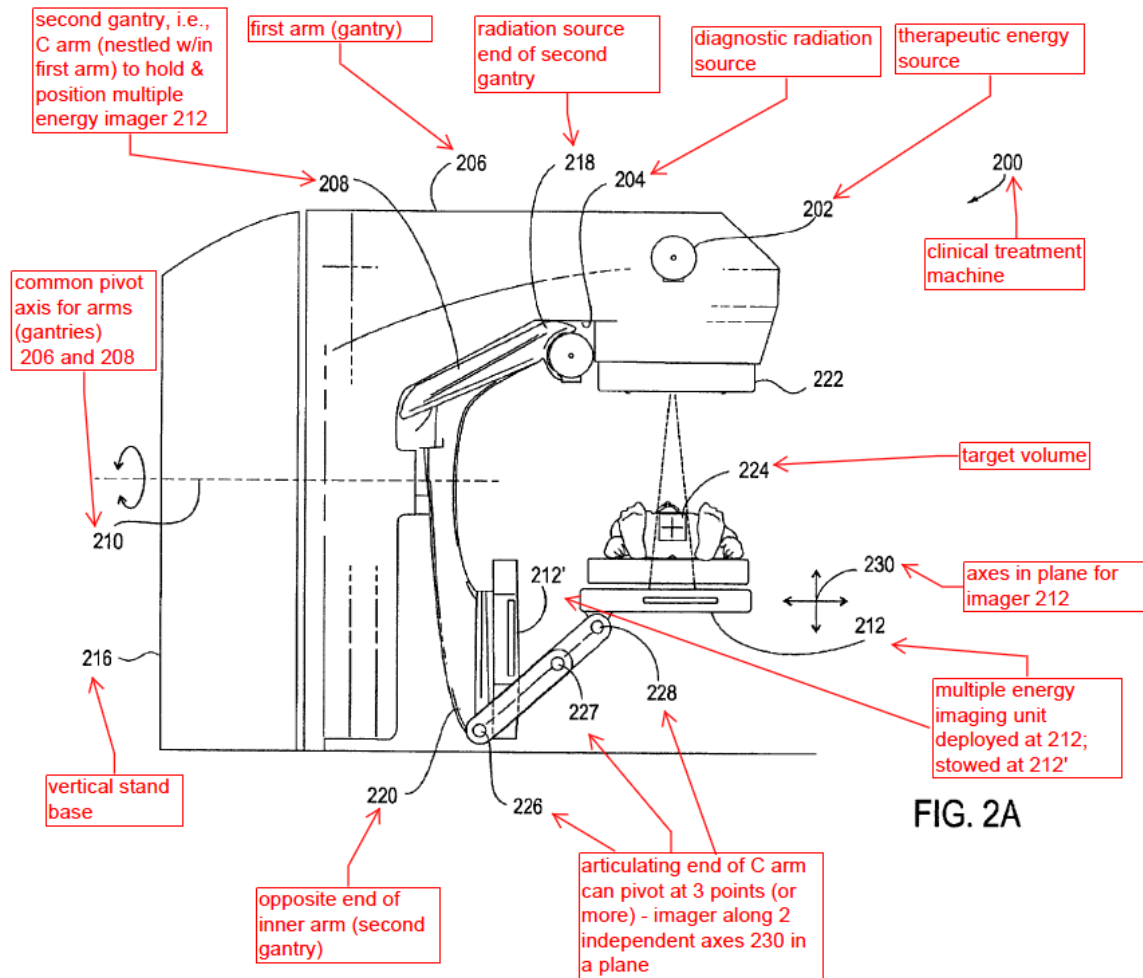

FIG. 2A

Annotated Version of Figure 2A of the '919 Patent

In Figure 2A therapeutic radiation source 202 is mounted on first arm (first gantry) 206, and diagnostic radiation source 204 is mounted on second arm (second gantry) 208 nestled within the first arm, with both arms on a common pivot axis 210 around which the arms can pivot independently. *Id.* at 5:12–18. The inner arm (second gantry) can extend and retract diagnostic radiation source 204 for positioning and clearance. *Id.* at 18–20. The first arm is attached pivotally to base stand 216 to permit 360 degree rotation of therapeutic energy source 204. Multiple-energy imager 212 can be attached at an articulating end 220 of inner arm (second gantry) 208 that is opposite

# Explore Litigation Insights

Docket Alarm provides insights to develop a more informed litigation strategy and the peace of mind of knowing you're on top of things.

## Real-Time Litigation Alerts



Keep your litigation team up-to-date with **real-time alerts** and advanced team management tools built for the enterprise, all while greatly reducing PACER spend.

Our comprehensive service means we can handle Federal, State, and Administrative courts across the country.

## Advanced Docket Research



With over 230 million records, Docket Alarm's cloud-native docket research platform finds what other services can't. Coverage includes Federal, State, plus PTAB, TTAB, ITC and NLRB decisions, all in one place.

Identify arguments that have been successful in the past with full text, pinpoint searching. Link to case law cited within any court document via Fastcase.

## Analytics At Your Fingertips



Learn what happened the last time a particular judge, opposing counsel or company faced cases similar to yours.

Advanced out-of-the-box PTAB and TTAB analytics are always at your fingertips.

## API

Docket Alarm offers a powerful API (application programming interface) to developers that want to integrate case filings into their apps.

## LAW FIRMS

Build custom dashboards for your attorneys and clients with live data direct from the court.

Automate many repetitive legal tasks like conflict checks, document management, and marketing.

## FINANCIAL INSTITUTIONS

Litigation and bankruptcy checks for companies and debtors.

## E-DISCOVERY AND LEGAL VENDORS

Sync your system to PACER to automate legal marketing.