

- [54] **METHOD AND APPARATUS FOR DIAGNOSTIC IMAGING IN RADIATION THERAPY**
- [76] Inventor: **Gideon Barnea**, 7887 E. Uhl St., No. 410, Tucson, Ariz. 85710
- [21] Appl. No.: **819,957**
- [22] Filed: **Jan. 13, 1992**
- [51] Int. Cl.⁵ **A61B 5/05**
- [52] U.S. Cl. **128/653.1; 378/65**
- [58] Field of Search **128/653.1; 378/65**

[56] **References Cited**

U.S. PATENT DOCUMENTS

| | | | |
|-----------|---------|-----------|-----------|
| 3,783,251 | 1/1974 | Pavkovich | 378/65 |
| 4,123,660 | 10/1978 | Horwitz | 378/65 |
| 4,930,509 | 6/1990 | Brisson | 128/653.1 |

OTHER PUBLICATIONS

Droege, R. T. et al., "Influence of Metal Screens on Contrast in Megavoltage X-Ray Imaging," *Med. Phys.* 6, 487-492, 1979.

Lutz, W. R. et al., "A Test Object for Evaluation of Portal Film" *Int. J. Radiat. Oncol. Biol. Phys.* 11, 631-634, 1985.

Munro, P. et al., "Therapy Imaging: A Signal-to-Noise Analysis of Metal Plate/Film Detectors," *Med. Phys.* 14, 975-984, 1987.

Mark, J. E. et al., "The Value of Frequent Treatment Verification Films in Reducing Localization Error in the Irradiation of Complex Fields," *Cancer*, 37, 2755-2761, 1976.

Huizenga et al. "Accuracy in Radiation Field Alignment in Head and Neck Cancer: A Prospective Study," *Rad. Oncol.* 11, 181-187, 1988.

Pearcy et al., "The Impact of Treatment Errors on Post-Operative Radiotherapy for Testicular Tumors," *Br. J. Radiol.* 58, 1003-1005, 1985.

Rabinowitz et al. "Accuracy of Radiation Field Alignment in Clinical Practice," *Int. J. Radiat. Oncol. Biol. Phys.* 11, 1857-1867, 1985.

Lam et al. "On-Line Measurement of Field Placement Errors in External Beam Radiotherapy," *Br. J. Radiol.* 60, 361-367, 1987.

Baily et al. "Fluoroscopic Visualization of Megavoltage Therapeutic X-Ray Beams," *Int. J. Radiat. Oncol. Biol. Phys.* 6, 935-939, 1980.

Herk et al., "A Digital Imaging System for Portal Verification," in *The Use of Computers in Radiation Therapy*, I. Brunvis Ed., North Holland, 371-373, 1987.

(List continued on next page.)

Primary Examiner—Lee S. Cohen
Assistant Examiner—Samuel Gilbert
Attorney, Agent, or Firm—Antonio R. Durando; Harry M. Weiss

[57] **ABSTRACT**

An apparatus for diagnostic and verification imaging in radiation therapy that consists of attachments for standard radiotherapy equipment comprising an x-ray tube and an x-ray detector placed on opposite sides of a patient along the main axis of the beam produced by the treatment unit. The detector is placed on a plane orthogonal to the axis of the treatment beam and between the beam source and the patient, while the x-ray tube is placed on the other side of the patient, coaxially with the treatment beam and facing the detector. As a result of this configuration, the radiographic view of the x-ray beam, as seen on the detector, is equivalent to the view produced on the same detector by the therapeutic beam, varied only by parallax deviations that can be corrected by geometrical calculations. Accordingly, x-ray exposures and real-time verification of the position of a patient can be obtained with the same unit used for treatment and without requiring movement of either patient or equipment. In addition, the apparatus enables a user to produce diagnostic images that can be used directly to manufacture shielding blocks in conventional shielding-block cutters.

10 Claims, 2 Drawing Sheets

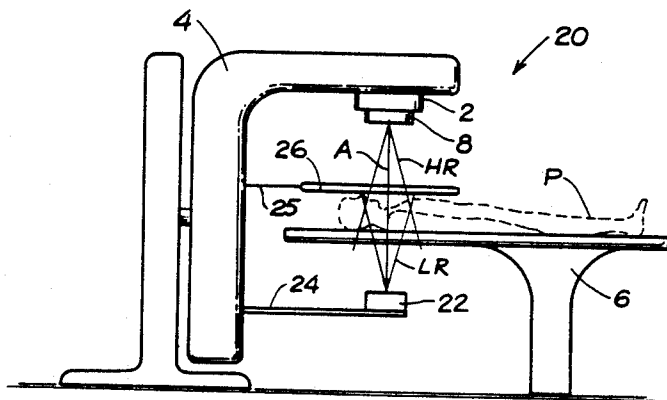

OTHER PUBLICATIONS

- Shalev et al. "Video Techniques for On-Line Portal Imaging," *Comp. Med. Imag. Graph.* 13, 217-226, 1989.
- Munro et al. "A Digital Fluoroscopic Imaging Device for Radiotherapy Localization," *Int. J. Radiat. Oncol. Biol. Phys.* 18, 641-649, 1990.
- Durham et al. "Portal Film Quality: A Multiple Institutional Study," *Med. Phys.* 11, 555-557, 1984.
- Biggs et al. "A Diagnostic X-Ray Field Verification Device for a 10 MV Accelerator," *Int. J. Radiat. Oncol. Biol. Phys.* 11, 635-643, 1985.
- Marks J. E. et al. "Localization in the Radiotherapy of Hodgkins Disease and Malignant Lymphoma with Extended Mantle Fields," *Cancer* 34, 83-90, 1974.
- Marks J. E. et al. "Dose-Response Analysis for Nasopharyngeal Carcinoma: An Historical Perspective," *Cancer* 50, 1042-1050 1982.
- White J. E. et al. "The Influence of Radiation Therapy Quality Control on Survival, Response and Sites of Relapse in Oat Cell Carcinoma of the Lung," *Cancer* 50, 1084-1090, 1982.
- Kinzie J. J. et al. "Patterns of Care Study: Hodgkins Disease Relapse Rates and Adequacy of Portals," *Cancer* 52, 2223-2226, 1983.

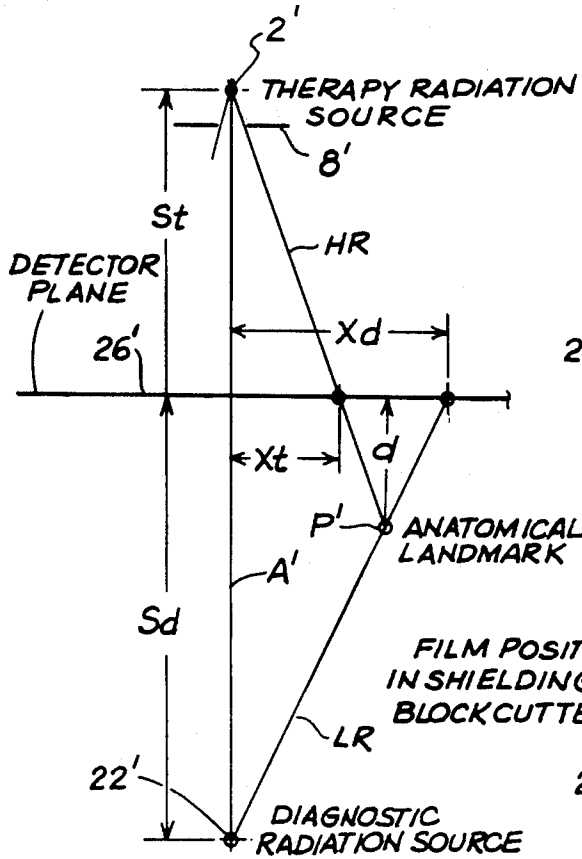

Fig. 3

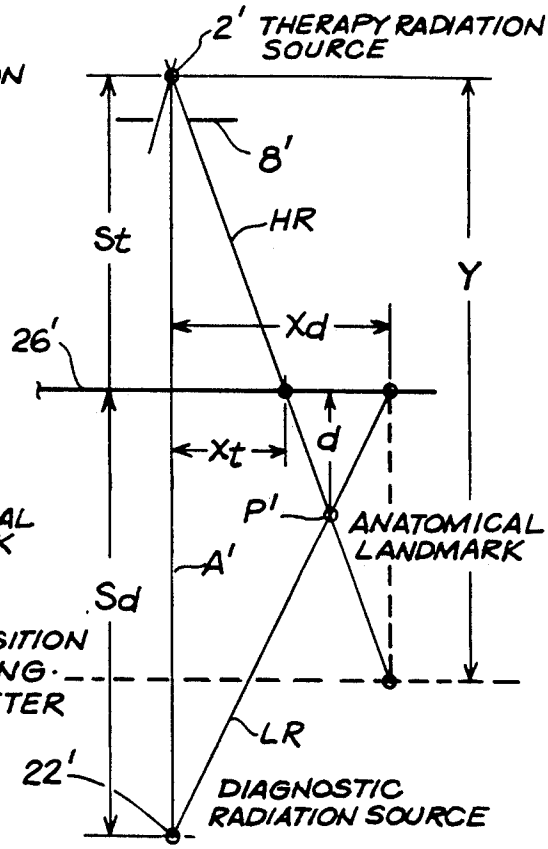

Fig. 4

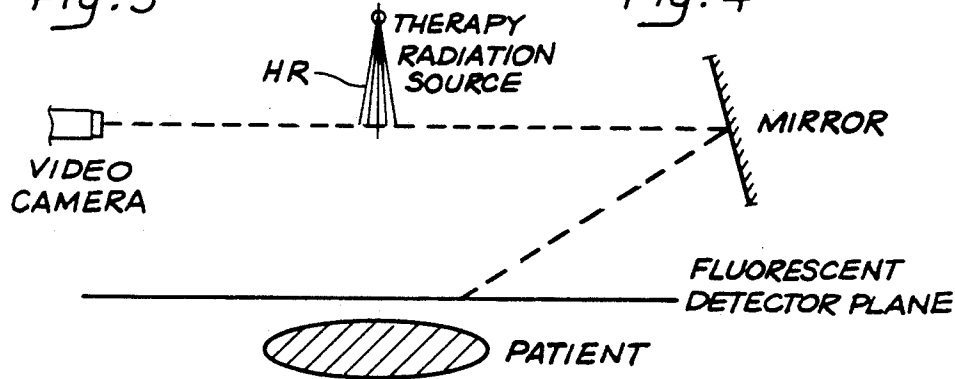

Fig. 5



METHOD AND APPARATUS FOR DIAGNOSTIC IMAGING IN RADIATION THERAPY

BACKGROUND OF THE INVENTION

1. Field of the Invention

This invention is related to the general field of radiation imaging for medical applications. In particular, the invention provides a new method and apparatus for producing a diagnostic image of the portion of the body affected by a tumor, so that the required dosage of radiation can be accurately delivered to the prescribed target volume.

2. Description of the Prior Art

The main object of radiotherapy is to deliver the prescribed dosage of radiation to a tumor in a patient while minimizing the damage to surrounding, healthy, tissue. Since very high energy radiation (produced at 4 to 25 million volts, typically generated by a linear accelerator) is normally used to destroy tumors in radiotherapy, the high energy is also destructive to the normal tissue surrounding the tumor. Therefore, it is essential that the delivery of radiation be limited precisely to the prescribed target volume (i.e., the tumor plus adequate margins), which is accomplished by placing appropriately constructed shielding blocks in the path of the radiation beam. Thus, the goal is to accurately identify the malignancy within the body of the patient and to target the prescribed dosage of radiation to the desired region on the immobilized patient.

To that end, the ideal procedure requires the identification of the exact anatomical location of the tumor and the corresponding accurate positioning of the radiation field during treatment. This could be easily achieved if it were possible to locate and treat the tumor at the same time. In practice, though, this is not possible because the equipment used to identify the tumor (x-ray machine, computed tomography equipment, or the like) is separate from the equipment used for the therapeutical irradiation of the patient, requiring the movement and repositioning of the patient from one piece of equipment to the other. As illustrated in schematic form in FIG. 1, a conventional treatment unit 10 consists of a linear accelerator (linac) head 2 mounted on a gantry 4 so that its collimated high-energy emissions HR irradiate a patient P lying on a gurney 6 directly below through shielding blocks 8 attached to the head. A bracket 12 supporting a detector 14 may be mounted on the opposite side of the head within the field of radiation in order to take radiographs of the patient being treated. The gantry 4 is movable around a pivot 16 to permit the rotation of the head (and of the detector) around the patient to afford different views of the area to be treated ("multiple fields" treatment). The normal procedure involves the use of a diagnostic simulator, which is a diagnostic x-ray machine with the same physical characteristics of the radiation therapy machine (schematically also represented by FIG. 1, where a diagnostic x-ray head replaces the linac head 2), so that the field of view of the low-energy x rays emitted in the simulator is the same as that of the high-energy radiation emitted in the radiation therapy machine. Prior to treatment, the patient is radiographed using the simulator and an image of the target area is obtained with low-energy radiation (in the order of 100 kVp), which yields good image quality. The exact target volume is then delineated on the radiograph by a physician and matching shielding blocks are constructed to limit the field of view of the irradiating

machine to the region so delineated. A mold of the shielding blocks is first cut out of plastic material (normally polystyrene) with a shielding-block cutter, a machine that reproduces exactly the relative positions of the linac head, the shielding blocks and the detector as they stand in the treatment unit. By using mechanical means, the shielding blocks are cut so that the field of irradiation from the treatment unit will correspond exactly to the area delineated by the physician on the diagnostic radiograph. The final shielding blocks are then made from the mold with lead alloys that attenuate considerably the propagation of radiation. Thus, the shielding blocks function as templates that limit the radiation treatment to the areas left open within the contour of the shielding blocks. In addition, it is common practice to mark the skin of a patient with reference markings that are used in aligning the position of the patient with the field of emission of the radiation therapy machine.

These apparently sound procedures in fact suffer from serious practical shortcomings. Errors in positioning the shielding blocks between the radiating source and the patient, as well as incorrect beam alignment and patient movement, all have a cumulative effect reducing the accuracy of the procedure. Even the markings on the skin of the patient may be the cause of alignment problems because of shifting of the skin with respect to the patient's internal anatomy as a result of body motion or, over a period of time, even of body changes. Thus, the area actually irradiated during the therapeutic session often does not correspond to the area delineated in the radiograph generated by the simulator.

Positioning errors during irradiation have been found to have very serious consequences for the successful prognosis of the treatment. For example, researchers have been able to correlate the recurrence of lymphoma to such positioning errors (J. E. Marks, A. G. Haus, H. G. Sutton and M. L. Griem, "Localization Error in the Radiotherapy of Hodgkin's Disease and Malignant Lymphoma with Extended Mantle Fields," *Cancer* 34, 83-90, 1974); and it has been found that improved tumor control of nasopharyngeal carcinomas can be related to greater accuracy in the delivery of calculated dosages of radiation (J. E. Marks, J. M. Bedwinek, F. Lee, J. A. Purdy and C. A. Perez, "Dose-Response Analysis for Nasopharyngeal Carcinoma: An Historical Perspective," *Cancer* 50, 1042-1050, 1982). Similarly, it has been found that shielding inaccuracies have resulted in significantly lower primary tumor control and survival of patients of oat cell lung cancer (J. E. White, T. Chen, J. McCracken, P. Kennedy, H. G. Seydel, G. Hartman, J. Mira, M. Khan, F. Y. Durrance and O. Skinner, "The Influence of Radiation Therapy Quality Control on Survival, Response and Sites of Relapse in Oat Cell Carcinoma of the Lung," *Cancer* 50, 1084-1090, 1982); and that the local recurrence of Hodgkin's disease was significantly higher when the radiation field did not adequately cover the tumor (J. J. Kinzie, G. E. Hanks, C. J. Maclean and S. Kramer, "Patterns of Care Study: Hodgkin's Disease Relapse Rates and Adequacy of Portals," *Cancer* 52, 2223-2226, 1983).

The only technique widely used today to check the accuracy of the radiation field is by imaging with the radiotherapy beam itself at the time of treatment. Prior to treatment, a "portal" image is obtained by using the therapy beam (at high energy) and the resulting exposure is visually compared with that taken with the simu-

Explore Litigation Insights

Docket Alarm provides insights to develop a more informed litigation strategy and the peace of mind of knowing you're on top of things.

Real-Time Litigation Alerts



Keep your litigation team up-to-date with **real-time alerts** and advanced team management tools built for the enterprise, all while greatly reducing PACER spend.

Our comprehensive service means we can handle Federal, State, and Administrative courts across the country.

Advanced Docket Research



With over 230 million records, Docket Alarm's cloud-native docket research platform finds what other services can't. Coverage includes Federal, State, plus PTAB, TTAB, ITC and NLRB decisions, all in one place.

Identify arguments that have been successful in the past with full text, pinpoint searching. Link to case law cited within any court document via Fastcase.

Analytics At Your Fingertips



Learn what happened the last time a particular judge, opposing counsel or company faced cases similar to yours.

Advanced out-of-the-box PTAB and TTAB analytics are always at your fingertips.

API

Docket Alarm offers a powerful API (application programming interface) to developers that want to integrate case filings into their apps.

LAW FIRMS

Build custom dashboards for your attorneys and clients with live data direct from the court.

Automate many repetitive legal tasks like conflict checks, document management, and marketing.

FINANCIAL INSTITUTIONS

Litigation and bankruptcy checks for companies and debtors.

E-DISCOVERY AND LEGAL VENDORS

Sync your system to PACER to automate legal marketing.