

UNITED STATES PATENT AND TRADEMARK OFFICE

---

BEFORE THE PATENT TRIAL AND APPEAL BOARD

---

APPLE INC.,

Petitioner,

v.

PAPST LICENSING GMBH & CO., KG,

Patent Owner.

---

Case IPR2016-01864

Patent 6,470,399 B1

---

Before JONI Y. CHANG, JAMES B. ARPIN, and MIRIAM L. QUINN,  
*Administrative Patent Judges.*

QUINN, *Administrative Patent Judge.*

DECISION

Institution of *Inter Partes* Review

37 C.F.R. § 42.108

## I. INTRODUCTION

Apple Inc. (“Petitioner”) filed a Petition requesting an *inter partes* review of claims 1, 3, 5, 11, and 14 (“the challenged claims”) of U.S. Patent No. 6,470,399 B1 (Ex. 1001, “the ’399 patent”). Paper 2 (“Pet.”). Papst Licensing GmbH & Co., KG (“Patent Owner”), filed a Preliminary Response. Paper 12 (“Prelim. Resp.”).

We have jurisdiction under 35 U.S.C. § 314. For the reasons that follow, we institute *inter partes* review of the claims challenged in the Petition.

### A. Related Matters

The parties indicate that the ’399 patent is involved in *Papst Licensing GmbH & Co. KG v. Apple, Inc.*, Case No. 6-15-cv-01095 (E.D. Tex.) and other proceedings. Pet. 2–3; Paper 9, 2–5.

### B. The ’399 Patent

The ’399 patent describes interface devices for communication between a computer host device and a data transmit/receive device (e.g., a multi-meter, transmitting measured data to a computer). Ex. 1001, 1:9–13, 1:48–51. According to the ’399 patent, using a specific driver to match very closely to an individual host system would achieve high data transfer rates across the interface, but the specific driver cannot be used with other host systems. *Id.* at 1:65–2:13. Several solutions to this problem were known in the art. *Id.* at 2:16–3:21. For example, IOtech offered an interface device for laptops, using a plug-in card for converting the personal computer

memory card association (“PCMCIA”) interface into a known standard interface (“IEEE 1284”). *Id.* at 2:16–24. The plug-in card provided a printer interface for enhancing data transfer rates. *Id.* at 2:24–28. In another example, a floppy disk drive interface was used for connecting a host device to a peripheral device. *Id.* at 3:6–10. The interface appeared as a floppy disk drive to the host, allowing a floppy disk drive and another peripheral device to be connected to the host device. *Id.* at 3:13–15.

The ’399 patent indicates that its “invention is based on the finding that both a high data transfer rate and host device-independent use can be achieved if a driver for an input/output device customary in a host device” is utilized. *Id.* at 4:23–27. Figure 1 of the ’399 patent, reproduced below, illustrates a block diagram of an interface device.

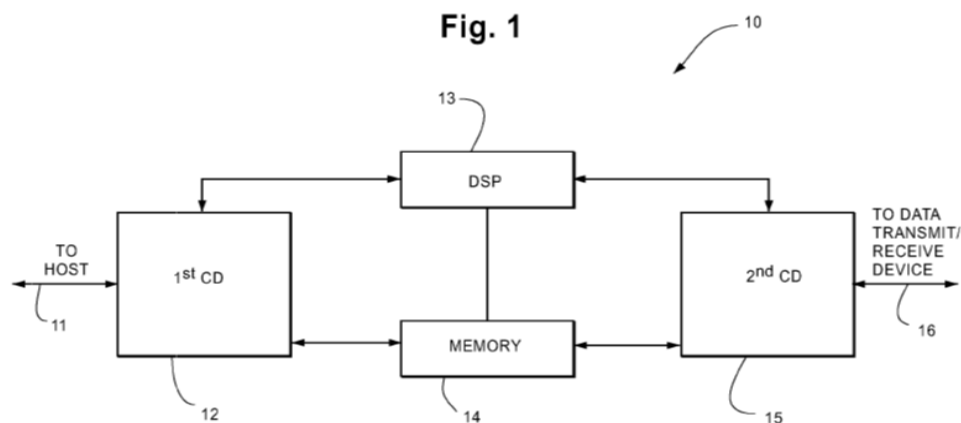

As shown in Figure 1 above, interface device 10 connects to a host device via host line 11, and to a data transmit/receive device via output line 16. *Id.* at 5:47–63. Interface device 10 includes first connecting device 12, second connecting device 15, digital signal processor 13, and memory means 14. *Id.* In a preferred embodiment, the interface device is

attached to a host device via a multi-purpose interface—e.g., a small computer systems interface (“SCSI”)—which includes both an interface card and the driver for the interface card. *Id.* at 4:40–46, 9:29–32. According to the ’399 patent, SCSI interfaces were known to be present on most host devices or laptops. *Id.* at 9:32–38. By using a standard interface of a host device and by simulating an input/output device to the host device, the interface device “is automatically supported by all known host systems without any additional sophisticated driver software.” *Id.* at 12:23–29.

### *C. Illustrative Claim*

Of the challenged claims, claims 1, 11, and 14 are independent. Each of claims 3 and 5 depends directly from claim 1. Claim 1 is illustrative:

1. An interface device for communication between a host device, which comprises drivers for input/output devices customary in a host device and a multi-purpose interface, and a data transmit/receive device, the data transmit/receive device being arranged for providing analog data, comprising:

a processor;

a memory;

a first connecting device for interfacing the host device with the interface device via the multi-purpose interface of the host device; and

a second connecting device for interfacing the interface device with the data transmit/receive device, the second connecting device including a sampling circuit for sampling the analog data provided by the data transmit/receive device and an analog-to-digital converter for converting data sampled by the sampling circuit into digital data,

wherein the interface device is configured by the processor and

the memory to include a first command interpreter and a second command interpreter,

wherein the first command interpreter is configured in such a way that the command interpreter, when receiving an inquiry from the host device as to a type of a device attached to the multi-purpose interface of the host device, sends a signal, regardless of the type of the data transmit/receive device attached to the second connecting device of the interface device, to the host device which signals to the host device that it is an input/output device customary in a host device, whereupon the host device communicates with the interface device by means of the driver for the input/output device customary in a host device, and

wherein the second command interpreter is configured to interpret a data request command from the host device to the type of input/output device signaled by the first command interpreter as a data transfer command for initiating a transfer of the digital data to the host device.

Ex. 1001, 12:42–13:12.

# Explore Litigation Insights

Docket Alarm provides insights to develop a more informed litigation strategy and the peace of mind of knowing you're on top of things.

## Real-Time Litigation Alerts



Keep your litigation team up-to-date with **real-time alerts** and advanced team management tools built for the enterprise, all while greatly reducing PACER spend.

Our comprehensive service means we can handle Federal, State, and Administrative courts across the country.

## Advanced Docket Research



With over 230 million records, Docket Alarm's cloud-native docket research platform finds what other services can't. Coverage includes Federal, State, plus PTAB, TTAB, ITC and NLRB decisions, all in one place.

Identify arguments that have been successful in the past with full text, pinpoint searching. Link to case law cited within any court document via Fastcase.

## Analytics At Your Fingertips



Learn what happened the last time a particular judge, opposing counsel or company faced cases similar to yours.

Advanced out-of-the-box PTAB and TTAB analytics are always at your fingertips.

## API

Docket Alarm offers a powerful API (application programming interface) to developers that want to integrate case filings into their apps.

## LAW FIRMS

Build custom dashboards for your attorneys and clients with live data direct from the court.

Automate many repetitive legal tasks like conflict checks, document management, and marketing.

## FINANCIAL INSTITUTIONS

Litigation and bankruptcy checks for companies and debtors.

## E-DISCOVERY AND LEGAL VENDORS

Sync your system to PACER to automate legal marketing.