



US00535374A

United States Patent [19]
Wilson et al.

[11] **Patent Number:** **5,353,374**
[45] **Date of Patent:** **Oct. 4, 1994**

- [54] **LOW BIT RATE VOICE TRANSMISSION FOR USE IN A NOISY ENVIRONMENT**
- [75] Inventors: **Dennis L. Wilson**, Palo Alto; **James L. Wayman**, Pebble Beach, both of Calif.
- [73] Assignee: **Loral Aerospace Corporation**, New York, N.Y.
- [21] Appl. No.: **963,101**
- [22] Filed: **Oct. 19, 1992**
- [51] Int. Cl.⁵ **G10L 9/14; G10L 3/02**
- [52] U.S. Cl. **395/2.35; 395/2.28**
- [58] **Field of Search** 381/29-40; 395/2.35, 2.28, 2.25-2.27, 2.36, 2.37

- [56] **References Cited**
- U.S. PATENT DOCUMENTS**
- | | | | |
|-----------|--------|---------------|----------|
| 4,718,087 | 1/1988 | Papamichalis | 395/2.31 |
| 4,720,861 | 1/1988 | Bertrand | 381/36 |
| 4,724,535 | 2/1988 | Ono | 375/122 |
| 4,752,956 | 6/1988 | Sluijter | 395/2.28 |
| 4,797,925 | 1/1989 | Lin | 395/2.32 |
| 4,815,134 | 3/1989 | Picone et al. | 395/2.31 |
| 4,864,620 | 9/1989 | Bialick | 395/2.16 |
| 4,903,303 | 2/1990 | Taguchi | 381/31 |
| 4,932,061 | 6/1990 | Kroon et al. | 395/2.32 |

OTHER PUBLICATIONS

Wayman et al., "Some Improvements on the Synchronized-Overlap-Add Method of Time Scale Modification for Use in Real-Time Speech Compression and

Noise Filtering", IEEE/ASSP Journal, Jan. 1988, pp. 139-140.

Primary Examiner—David D. Knepper
Attorney, Agent, or Firm—Perman & Green

[57] **ABSTRACT**

A compressing a voice signal by the steps of (a) digitizing an input signal that includes a voice signal, the input signal including a coherent noise component; and (b) compressing the digitized voice signal with a synchronized overlap add processor (20). So as to prevent the synchronized overlap add processor from locking to the coherent noise component, the step of compressing includes an initial step of applying the digitized input signal to a linear predictor (16), the linear predictor having time constants selected for attenuating the coherent noise component of the input signal. The residual signal output of the linear predictor includes the voice signal, and an uncorrelated noise component if one is present in the input signal. The operation of the synchronized overlap add processor also functions to attenuate the incoherent noise component. Further compression of the compressed voice signal is accomplished by Huffman coding, arithmetic coding, or transform coding so as to provide a greatly compressed voice signal that, when subsequently expanded, is found to exhibit excellent voice quality.

17 Claims, 3 Drawing Sheets

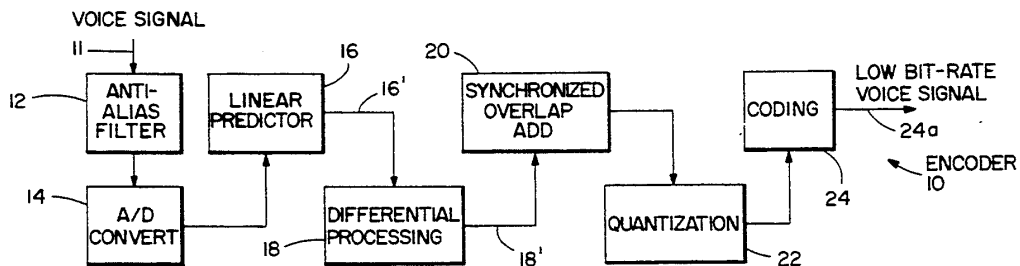

FIG. 1

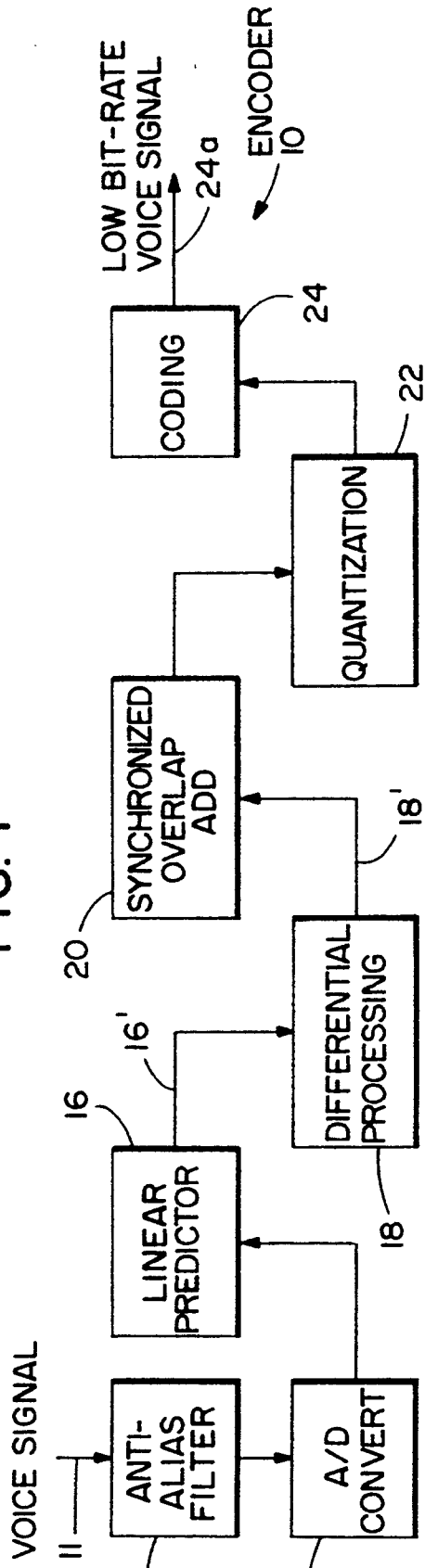

FIG. 2

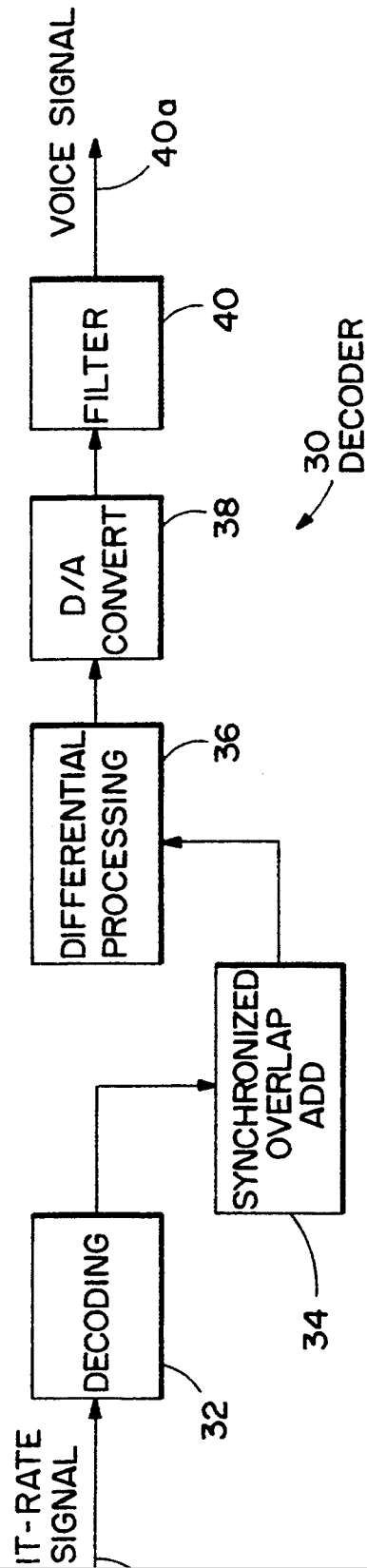

FIG. 3

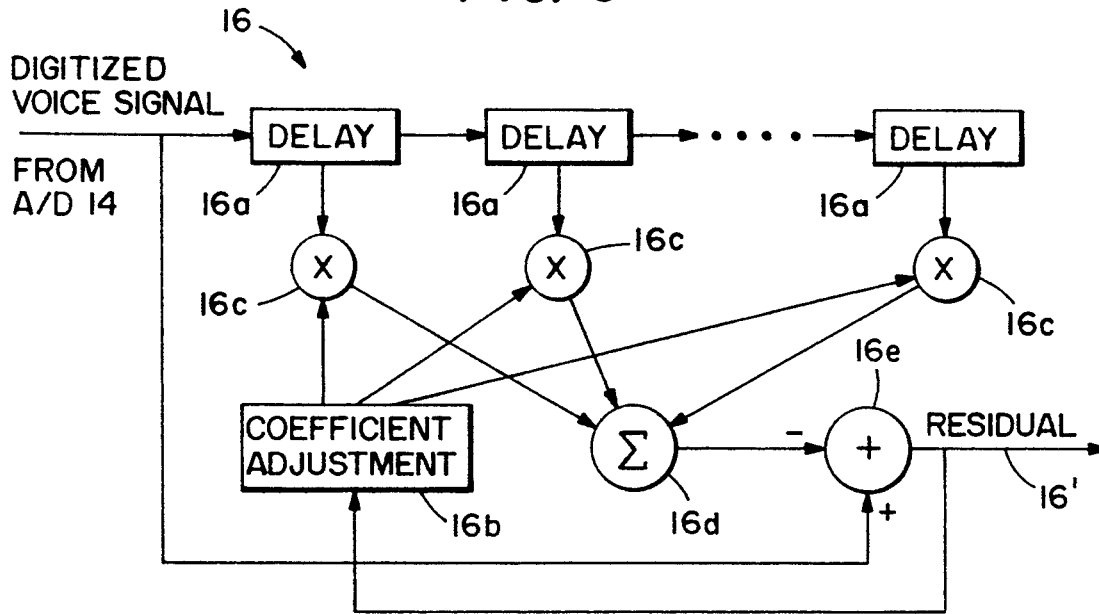

FIG. 4

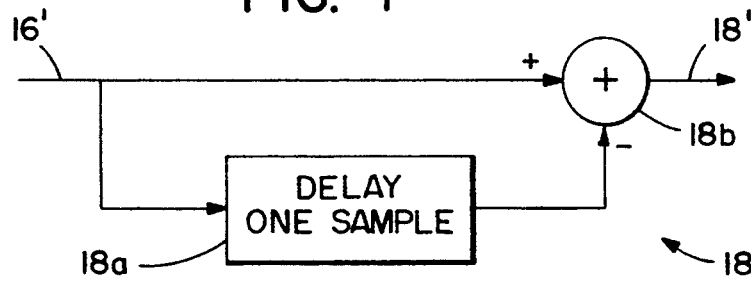

FIG. 5

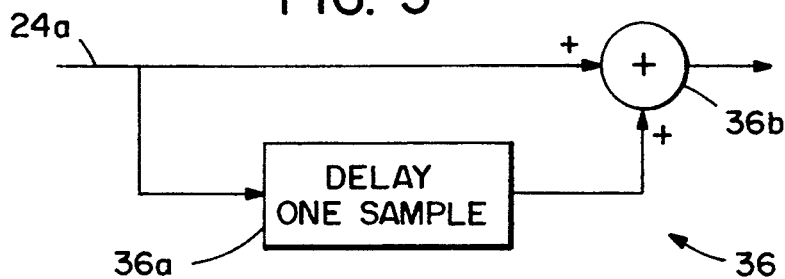
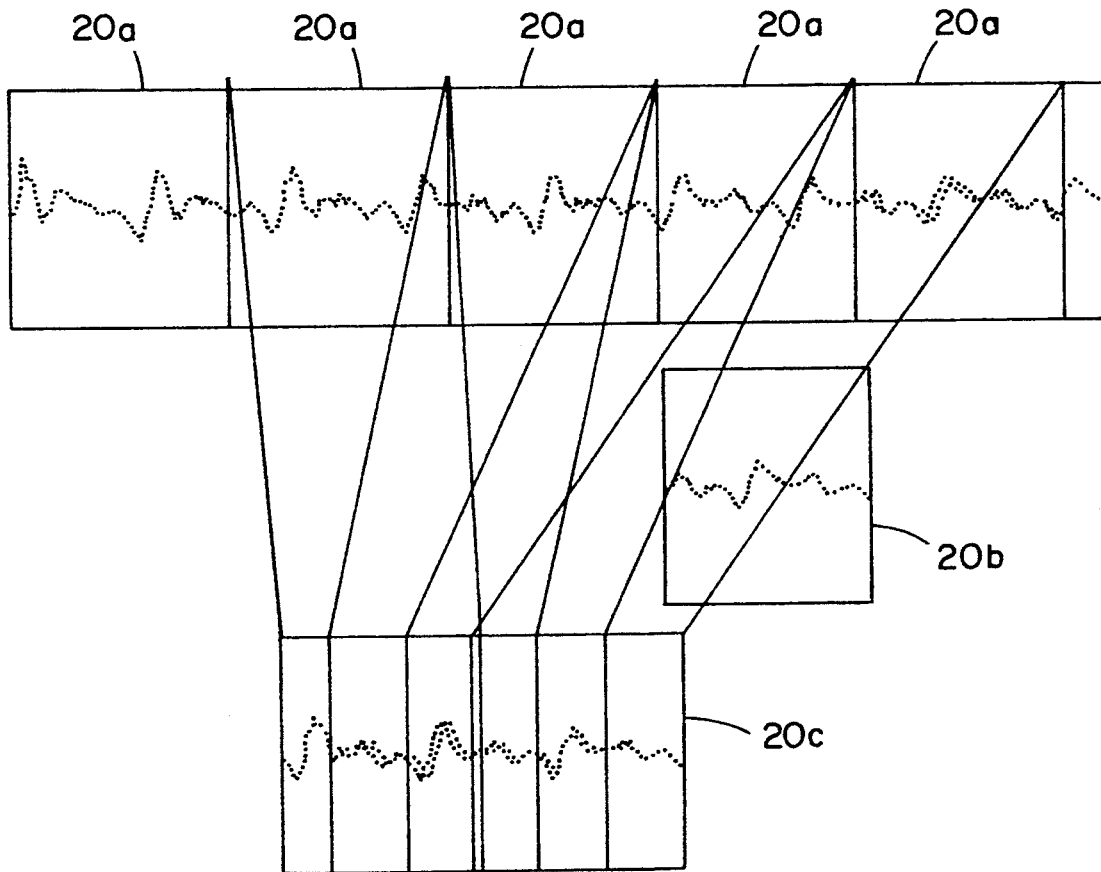

FIG. 6



LOW BIT RATE VOICE TRANSMISSION FOR USE IN A NOISY ENVIRONMENT

FIELD OF THE INVENTION

This invention relates generally to voice communication methods and apparatus and, in particular, to methods and apparatus for transmitting a compressed digitized voice signal in the presence of noise.

BACKGROUND OF THE INVENTION

There are many applications where a very low bit rate digitized voice signal is useful. For example, any communication system having a limited bandwidth can implement more voice channels within the bandwidth if the voice data rate is reduced. Examples of such communication systems include, but are not limited to, cellular telephone systems and satellite communications systems, such as those that employ L band communications. In general, any satellite communication scheme can employ bit reduction techniques to simplify the processing of the signals.

A primary example of the use of low bit rate voice signals is the enciphered telephone system used by the military and intelligence communities. One conventional approach for maintaining privacy on telephone uses a 16 kbit/s continuously variable slope delta modulation scheme (CVSD) in the transmission of the voice signals. However, the quality of the voice is notoriously poor, and would most likely not be used were it not for the sensitive nature of the conversations. When the bit rate is expanded to 32 kbits per second, the quality of the CVSD voice is quite good, but the data rate is large enough to consume considerably more communication bandwidth than the usual telephone channel. By comparison, a standard digital telephone channel uses 64 kbits per second.

Another known technique that is used to achieve low bit rates is linear predictive coding (LPC). Linear predictive coding achieves bit rates of 2.4 kbits per second for poor quality, but intelligible speech. However, it is often impossible to recognize the speaker when using the LPC speech.

Furthermore, LPC exhibits a problem when a noise signal coexists with the desired voice signal, in that the prediction algorithm adapts to the noise as well as to the speech. The result is that, for low signal-to-noise ratios, the speech signal may nearly disappear. This is because the noise signal "captures" the Linear Predictive Coder, and any residual of the voice signal is greatly reduced in amplitude and quality. LPC furthermore has difficulty with both white noise and with coherent noise. Examples of coherent noise are 60 Hz hum and the hum of machinery.

The following U.S. Patents all disclose various aspects of Linear Predictive Coding (LPC) as applied to speech: U.S. Pat. No. 4,718,087, entitled "Method and System Encoding Digital Speech Information", by Panagiotis E. Papamichalis; U.S. Pat. No. 4,720,861, entitled "Digital Speech Coding Circuit", by John P. Bertrand; U.S. Pat. No. 4,724,535, entitled "Low Bit-Rate Pattern Coding with Recursive Orthogonal Decision of Parameters", by Shigeru Ono; U.S. Pat. No. 4,797,925, entitled "Method for Coding Speech at Low Bit Rates", by Daniel Lin; U.S. Pat. No. 4,815,134, entitled "Very Low Rate Speech Encoder and De-

A Low Transmission Rate", by Tetsu Taguchi; and U.S. Pat. No. 4,932,061, entitled "Multi-Pulse Excitation Linear-Predictive Speech Coder", by Peter Kroon et al.

Other known voice encoding techniques are not degraded by white noise, but do have difficulty with coherent noise. One example of such a technique is known as Synchronized-Overlap-Add (SOLA). By example, U.S. Pat. No. 4,864,620, entitled "Method for Performing Time-Scale Modification of Speech Information or Speech Signals", by L. Bialik discloses a method for determining a value of an overlap and a windowing of the speech signal. However, it is believed that the presence of correlated noise will capture the overlap calculation and degrade the speech quality.

The present inventors describe an improved SOLA technique in an article entitled. "Some improvements on the synchronized-overlap-add method of time-domain modification for real-time speech compression and noise filtering", IEEE Journal on Acoust. Speech and signal Proc., Vol. 36, 1988, pp. 139-40.

One of the most severe environments for voice compression is in a vehicle where there exists both white noise, due to, for example, the wind, and coherent road noise and motor noise. Achievement of low bit rate voice encoding in these circumstances is difficult.

It is thus one object of this invention to provide a low bit rate voice encoding technique that provides intelligible speech at low signal-to-noise ratios.

It is a further object of this invention to improve the signal-to-noise ratio for low bit rate encoded speech, and to suppress both white noise and coherent noise when digitally encoding speech.

SUMMARY OF THE INVENTION

The foregoing and other problems are overcome and the objects of the invention are realized by a low bit rate method for the transmission of voice signals, and by apparatus for accomplishing the method. Bit rates of one to two kbits per second, and below, are achieved for very good quality voice, where the speech is intelligible and the speaker is easily recognizable. The low bit rates are readily accomplished with the disclosed method when the voice signal has little interfering noise and, also, in the presence of both white noise and correlated noise. The method of the invention thus finds application in noisy environments, such as in vehicles or areas where machinery is in use.

In accordance with the invention, there is provided a method for compressing a voice signal by the steps of (a) digitizing an input signal that includes a voice signal, the input signal including a coherent noise component; and (b) compressing the voice signal with a synchronized overlap add processor. So as to prevent the synchronized overlap add processor from locking to the coherent noise component, the step of compressing includes an initial step of applying the digitized input signal to a linear predictor, the linear predictor having time constants selected for attenuating the coherent noise component of the input signal, but not significantly attenuating the voice signal. The residual signal output of the linear predictor thus includes the voice signal and also an uncorrelated noise component, if one is present in the input signal. The operation of the syn-

Explore Litigation Insights

Docket Alarm provides insights to develop a more informed litigation strategy and the peace of mind of knowing you're on top of things.

Real-Time Litigation Alerts



Keep your litigation team up-to-date with **real-time alerts** and advanced team management tools built for the enterprise, all while greatly reducing PACER spend.

Our comprehensive service means we can handle Federal, State, and Administrative courts across the country.

Advanced Docket Research



With over 230 million records, Docket Alarm's cloud-native docket research platform finds what other services can't. Coverage includes Federal, State, plus PTAB, TTAB, ITC and NLRB decisions, all in one place.

Identify arguments that have been successful in the past with full text, pinpoint searching. Link to case law cited within any court document via Fastcase.

Analytics At Your Fingertips



Learn what happened the last time a particular judge, opposing counsel or company faced cases similar to yours.

Advanced out-of-the-box PTAB and TTAB analytics are always at your fingertips.

API

Docket Alarm offers a powerful API (application programming interface) to developers that want to integrate case filings into their apps.

LAW FIRMS

Build custom dashboards for your attorneys and clients with live data direct from the court.

Automate many repetitive legal tasks like conflict checks, document management, and marketing.

FINANCIAL INSTITUTIONS

Litigation and bankruptcy checks for companies and debtors.

E-DISCOVERY AND LEGAL VENDORS

Sync your system to PACER to automate legal marketing.