



US005623556A

United States Patent [19]

[11] Patent Number: **5,623,556**

Murayama et al.

[45] Date of Patent: **Apr. 22, 1997**

[54] **SYSTEM AND METHOD OF EXTRACTING BINARY IMAGE DATA**

[75] Inventors: **Masayoshi Murayama; Shigehiro Kajihara; Fumitaka Sato**, all of Tokyo, Japan

[73] Assignee: **Kabushiki Kaisha Toshiba**, Kawasaki, Japan

[21] Appl. No.: **368,719**

[22] Filed: **Jan. 4, 1995**

Related U.S. Application Data

[63] Continuation of Ser. No. 108,292, Aug. 19, 1993, abandoned, which is a continuation of Ser. No. 737,030, Jul. 29, 1991, abandoned.

Foreign Application Priority Data

Jul. 31, 1990 [JP] Japan 2-201539

[51] Int. Cl.⁶ **G06T 9/00**

[52] U.S. Cl. **382/233; 358/261.4**

[58] Field of Search 358/261.1, 261.3, 358/261.4, 261.2, 432, 453; 382/56, 232, 245, 233

References Cited

U.S. PATENT DOCUMENTS

3,723,641 3/1973 Heinrich et al. 358/261.4

4,700,402	10/1987	Okai et al.	382/56
4,725,815	2/1988	Mitchell et al.	358/261.3
4,748,512	5/1988	Armstrong	358/261.1
4,760,461	7/1988	Sato	358/432
4,843,632	6/1989	Lee et al.	358/261.1
4,884,147	11/1989	Arimoto et al.	358/261.1
5,086,434	2/1992	Abe et al.	358/453

FOREIGN PATENT DOCUMENTS

63-33350 7/1988 Japan .

OTHER PUBLICATIONS

Japanese Patent Publication No. 63-33350 Hitoshi Miyai et al., "Coded Image Storage Apparatus," (NEC Corporation), published Jul. 5, 1988.

Primary Examiner—Michael T. Razavi

Assistant Examiner—Jon Chang

Attorney, Agent, or Firm—Finnegan, Henderson, Farabow, Garrett & Dunner, L.L.P.

[57] ABSTRACT

For each of multiple segments acquired by dividing a binary image by a predetermined under of lines, image data of a reference line corresponding to a start line of that segment is stored in an intermediate start table in association with data indicating a head coding position of the start line in code data acquired when the binary image is compressed. Based on the stored data, partial image extraction is executed.

5 Claims, 3 Drawing Sheets

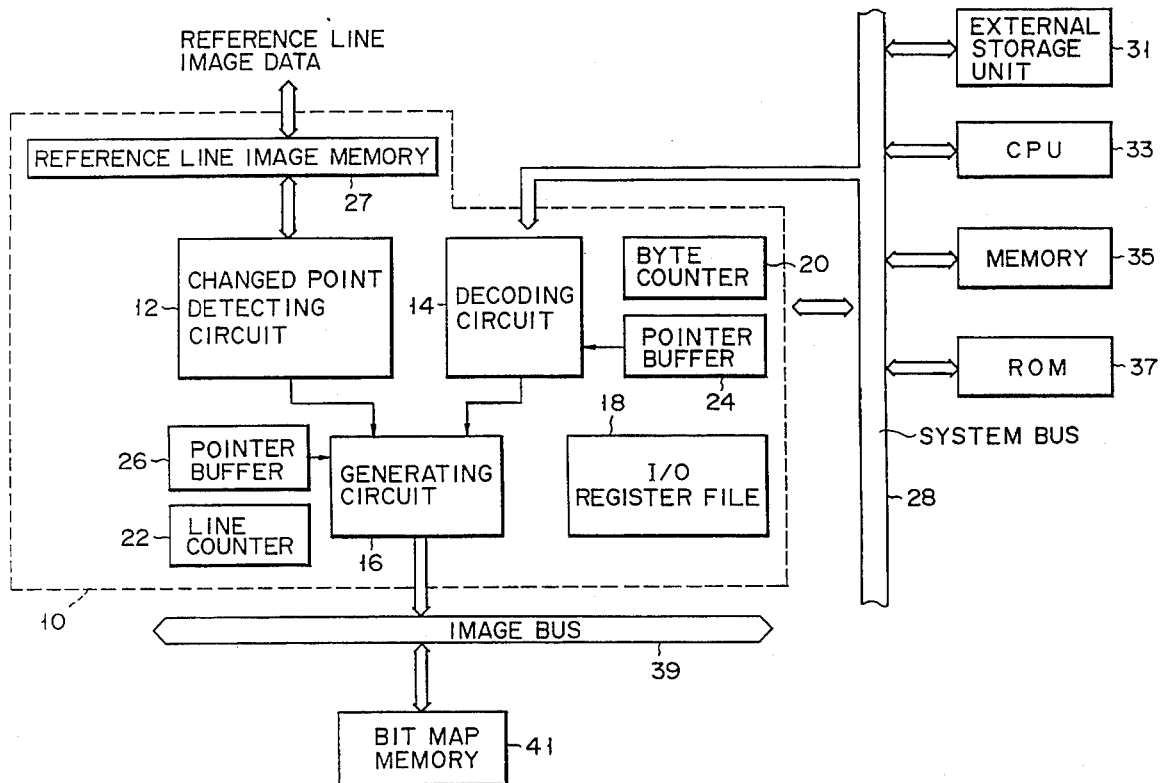

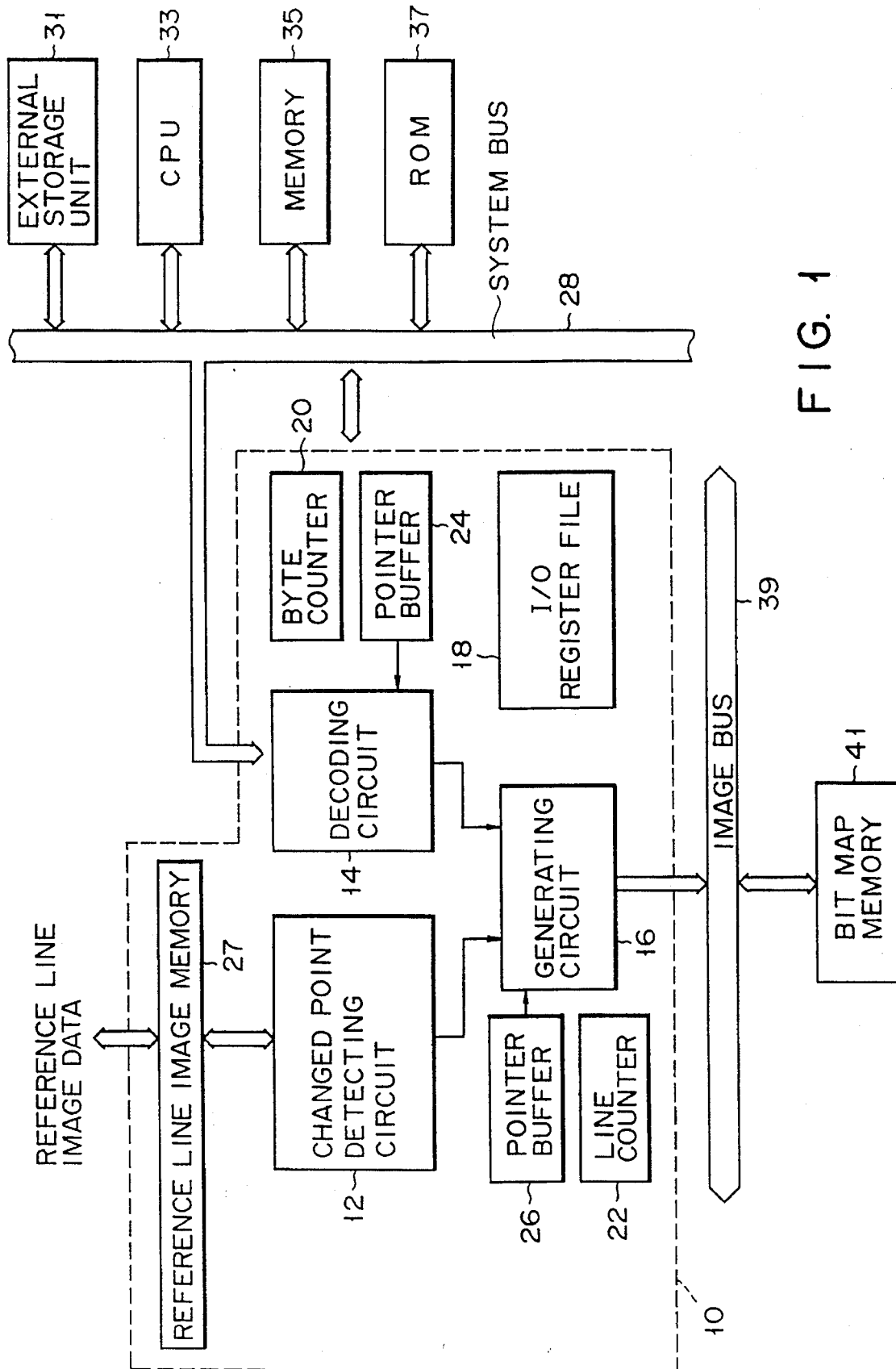

FIG. 1

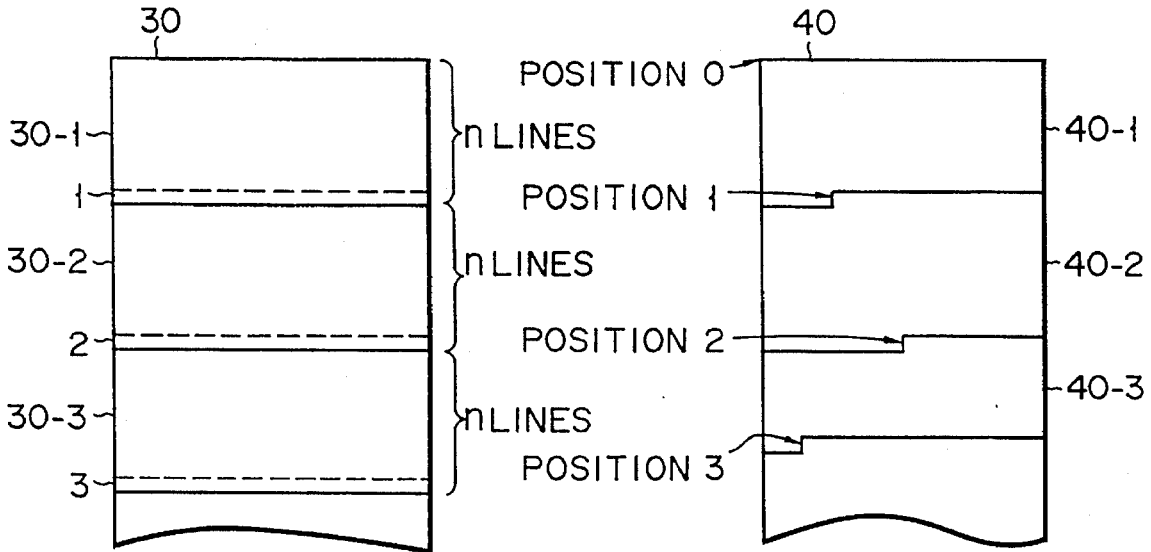

FIG. 2

FIG. 3

	REFERENCE LINE	CODE START POSITION
50	0 ----- 0	POSITION 0
	LINE 1	POSITION 1
	LINE 2	POSITION 2
	LINE 3	POSITION 3

FIG. 4

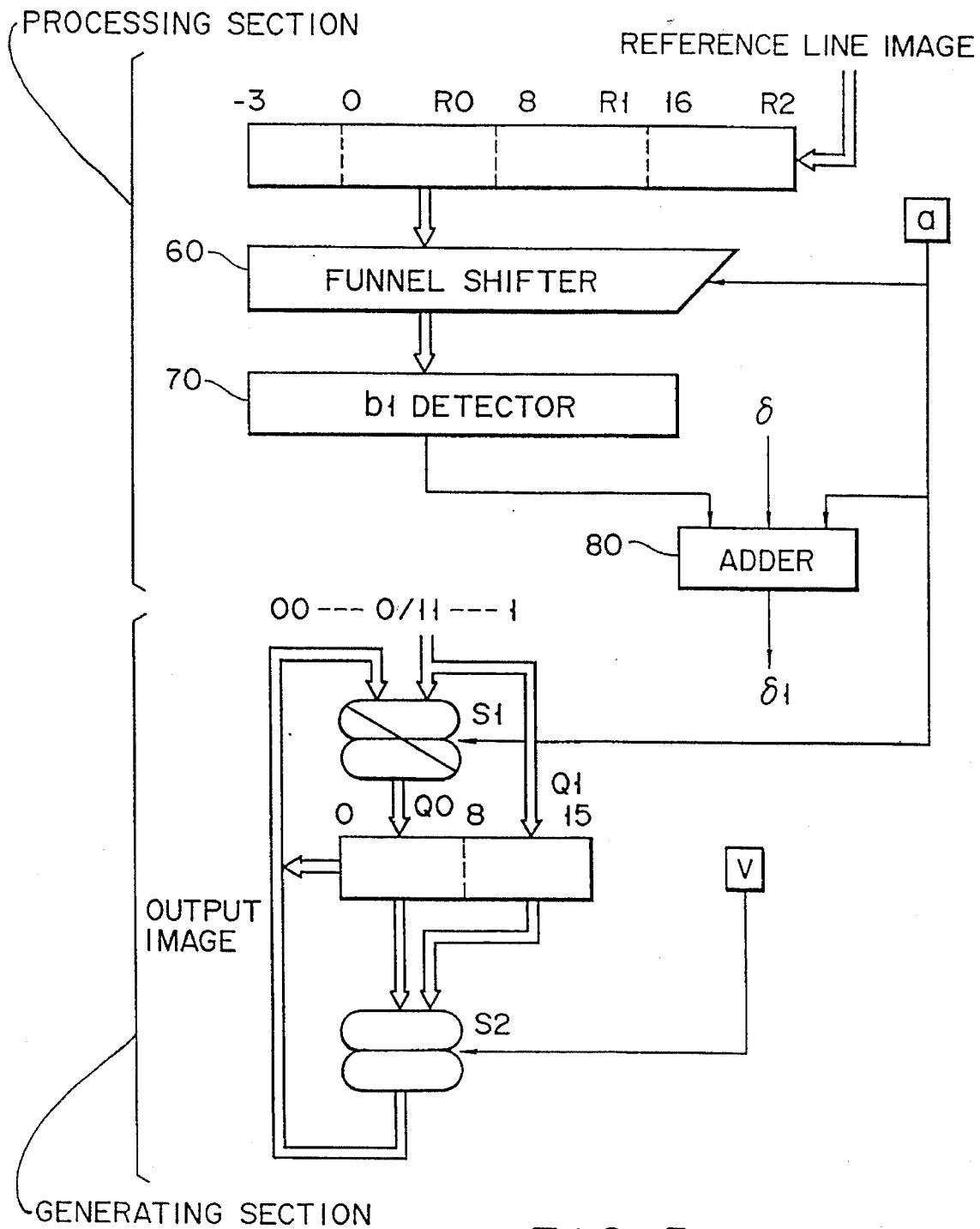

FIG. 5

SYSTEM AND METHOD OF EXTRACTING BINARY IMAGE DATA

This application is a continuation of application Ser. No. 08/108,292, filed Aug. 19, 1993, now abandoned which is a continuation of application Ser. No. 07/737,030, filed Jul. 29, 1991, now abandoned.

BACKGROUND OF THE INVENTION

1. Field of the Invention

The present invention relates to a binary image data extracting a system and method for extracting part of large image data in a binary image compression/expansion apparatus.

2. Description of the Related Art

A binary image compression/expansion apparatus handling a great amount of binary image data usually encodes binary image data to speed up the data transfer. Typical coding systems used for this type of apparatus are the MH (Modified Huffman) system, MR (Modified Read) system and MMR (Modified MR) system.

To extract part of image data from a binary image coded by the MH, MR or MMR coding system, all code data are expanded and developed into the original image before the extraction.

According to the above method, however, a large amount of image data which does not directly concern the extraction must be developed. As the original image becomes larger, therefore, image expansion takes more time, and the image memory needs a larger capacity.

Examined Japanese Patent Publication No. 63-33350 discloses a method for dividing a binary image into segments and encoding a head line of each segment in the one-dimensional coding system. This method cannot however be used with the MMR system which encodes binary image data with every line having a correlation with multiple lines. This method also cannot cope with the MR system if the head line of each segment is coded in a two-dimensional coding system.

SUMMARY OF THE INVENTION

It is therefore an object of the present invention to provide a binary image extracting system and method capable of quickly extracting part of even a large binary image based on code data.

To achieve this object, a system for compressing and expanding a binary image according to the first aspect of the present invention comprises: means for dividing the binary image into multiple segments by a predetermined number of lines; coding position data storing means for storing image data of a reference line corresponding to a start line of each of the divided segments, in association with that data in code data acquired when the binary image is compressed which indicates a head coding position of the start line; and means for producing an image based on the data stored in the coding position data storing means.

A system for compressing and expanding a binary image according to the second aspect of the present invention comprises: means for dividing the binary image into multiple segments by a predetermined number of lines; coding position data storing means for storing image data of a reference line corresponding to a start line of each of the divided segments, in association with that data in code data

acates a head coding position of the start line; and means for extracting part of the binary image based on the data stored in the coding position data storing means.

A system for compressing and expanding a binary image according to the third aspect of the present invention comprises: binary image compressing/expanding means for executing a compressing process to produce code data based on data of a binary image and an expanding process to produce a binary image based on the code data; means for dividing the binary image into multiple segments by a predetermined number of lines based on data acquired by processing done by the binary image compressing/expanding means; coding position data storing means for storing image data of a reference line corresponding to a start line of each of the divided segments, in association with that data in the code data acquired when the binary image is compressed which indicates a head coding position of the start line; code data storing means for storing code data to be handled in the binary image compressing/expanding means; and means for extracting and expanding the code data stored in the code data storing means to produce an image, based on the data stored in the coding position data storing means at a time the binary image compressing/expanding means extracts part of the binary image.

According to the present invention, since image data of a reference line corresponding to the start line of an image segment is stored in a memory in association with that data in code data which indicates the head coding position of the start line, the image data of the reference line can be referred to when extracting part of an image or expanding image data corresponding to the desired extraction area. This feature can permit the use of the MMR system as well as the two-dimensional coding line in the MR system.

In particular, the binary image compressing/expanding means is designed to skip reading code data stored in the code data storing means to avoid expanding the unnecessary data, thus speeding up the image extraction.

The coding position data storing means stores image data of the reference line and data indicating the head coding position of the start line in the compressing process or expanding process based on the contents of line number holding means, byte number counting means, bit position holding means, reference line holding means and line number counting means all provided in the binary image compressing/expanding means.

Additional objects and advantages of the invention will be set forth in the description which follows, and in part will be obvious from the description, or may be learned by practice of the invention. The objects and advantages of the invention may be realized and obtained by means of the instrumentalities and combinations particularly pointed out in the appended claims.

BRIEF DESCRIPTION OF THE DRAWINGS

The accompanying drawings, which are incorporated in and constitute a part of the specification, illustrate a presently preferred embodiment of the invention, and together with the general description given above and the detailed description of the preferred embodiment given below, serve to explain the principles of the invention.

FIG. 1 is a block diagram illustrating the structure of a binary image compressing/expanding apparatus in a system using a binary image data extracting system according to

Explore Litigation Insights

Docket Alarm provides insights to develop a more informed litigation strategy and the peace of mind of knowing you're on top of things.

Real-Time Litigation Alerts



Keep your litigation team up-to-date with **real-time alerts** and advanced team management tools built for the enterprise, all while greatly reducing PACER spend.

Our comprehensive service means we can handle Federal, State, and Administrative courts across the country.

Advanced Docket Research



With over 230 million records, Docket Alarm's cloud-native docket research platform finds what other services can't. Coverage includes Federal, State, plus PTAB, TTAB, ITC and NLRB decisions, all in one place.

Identify arguments that have been successful in the past with full text, pinpoint searching. Link to case law cited within any court document via Fastcase.

Analytics At Your Fingertips



Learn what happened the last time a particular judge, opposing counsel or company faced cases similar to yours.

Advanced out-of-the-box PTAB and TTAB analytics are always at your fingertips.

API

Docket Alarm offers a powerful API (application programming interface) to developers that want to integrate case filings into their apps.

LAW FIRMS

Build custom dashboards for your attorneys and clients with live data direct from the court.

Automate many repetitive legal tasks like conflict checks, document management, and marketing.

FINANCIAL INSTITUTIONS

Litigation and bankruptcy checks for companies and debtors.

E-DISCOVERY AND LEGAL VENDORS

Sync your system to PACER to automate legal marketing.