

(12) **United States Patent**
Rutledge, Sr. et al.

(10) **Patent No.:** **US 8,062,463 B2**
(45) **Date of Patent:** **Nov. 22, 2011**

(54) **METHOD OF ASSEMBLING SUCKER RODS AND END FITTINGS**

(75) Inventors: **Russell P. Rutledge, Sr.**, Big Spring, TX (US); **Russell P. Rutledge, Jr.**, Big Spring, TX (US); **Richard D. Burchett**, Coahoma, TX (US); **Floyd L. Brownfield**, Big Spring, TX (US)

(73) Assignee: **Fiberod, Inc.**, Morton Grove, IL (US)

(*) Notice: Subject to any disclaimer, the term of this patent is extended or adjusted under 35 U.S.C. 154(b) by 892 days.

(21) Appl. No.: **11/715,087**

(22) Filed: **Mar. 5, 2007**

(65) **Prior Publication Data**
US 2008/0217914 A1 Sep. 11, 2008

(51) **Int. Cl.**
B29C 65/00 (2006.01)
B29C 47/00 (2006.01)
B32B 37/00 (2006.01)
C08J 5/00 (2006.01)
B25G 3/34 (2006.01)
F16B 11/00 (2006.01)
F16B 12/04 (2006.01)
F16L 13/00 (2006.01)
G05G 1/12 (2006.01)

(52) **U.S. Cl.** **156/289**; 156/244.13; 156/293; 156/307.1; 403/268; 403/361

(58) **Field of Classification Search** 156/91, 156/153, 157, 158, 242, 244.11, 244.13, 156/244.24, 278, 281, 289, 293, 294, 296, 156/303.1, 304.1, 304.2, 304.3, 304.6, 307.1, 156/307.3, 307.5, 307.7; 403/265, 267, 268, 403/269, 345, 361

See application file for complete search history.

(56) **References Cited**

U.S. PATENT DOCUMENTS

3,168,340	A	2/1965	Howard	
4,315,699	A	2/1982	Lusk	
4,360,288	A	11/1982	Rutledge et al.	
4,401,396	A *	8/1983	McKay	403/13
4,430,018	A *	2/1984	Fischer	403/268
4,475,839	A	10/1984	Strandberg	
4,563,391	A *	1/1986	Tanner et al.	428/365
4,597,688	A *	7/1986	Pagan	403/265
4,662,774	A	5/1987	Morrow	
RE32,865	E	2/1989	Rutledge et al.	
4,822,201	A	4/1989	Iwasaki et al.	
4,919,560	A	4/1990	Rutledge et al.	

(Continued)

OTHER PUBLICATIONS

U.S. Patent & Trademark Office, Office Action in U.S. Appl. No. 11/715,088 (Dec. 30, 2010).

Primary Examiner — Philip C Tucker

Assistant Examiner — Brian R Slawski

(74) *Attorney, Agent, or Firm* — Leydig, Voit & Mayer, Ltd.

(57) **ABSTRACT**

An improved design and a method of assembly of end fittings to sucker rods which may be of conventional length or continuous sucker rods is described herein. The end fittings and rods are assembled so as to form wedges which enhance the connectability of the end fitting to the rod, and further, the wedge or wedges approach the rod asymptotically so as to avoid any abrupt discontinuities in the wedge or wedges thus substantially eliminating stress concentration areas and potential failure areas in the rod. The assembly method provides for integrity in the rod to end fitting assembly to promote longer connection life and fewer shop rejections and field failures.

12 Claims, 4 Drawing Sheets

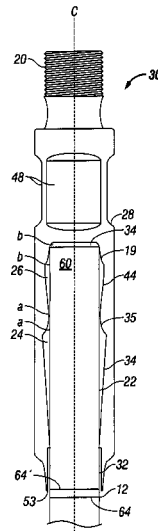

US 8,062,463 B2

Page 2

U.S. PATENT DOCUMENTS								
5,088,638	A *	2/1992	Karaev et al.	228/112.1	6,886,484	B2 *	5/2005 Thomas	114/108
5,253,946	A	10/1993	Watkins		2005/0000689	A1 *	1/2005 Peleanu et al.	166/279
6,193,431	B1 *	2/2001	Rutledge	403/268	2008/0217023	A1	9/2008 Rutledge	

* cited by examiner

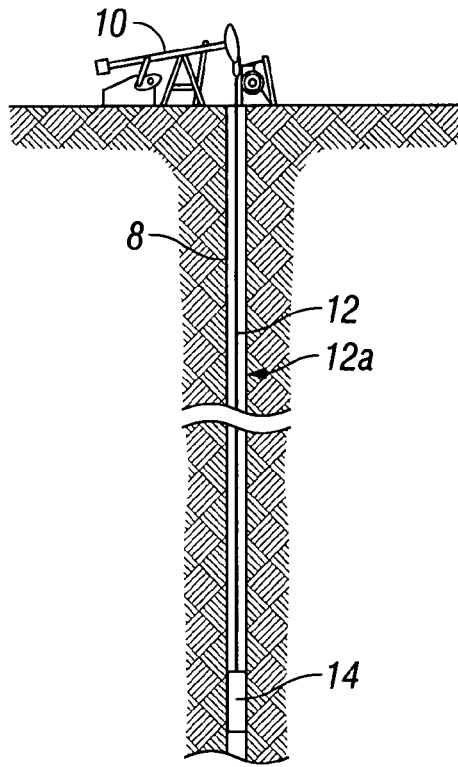

FIG. 1

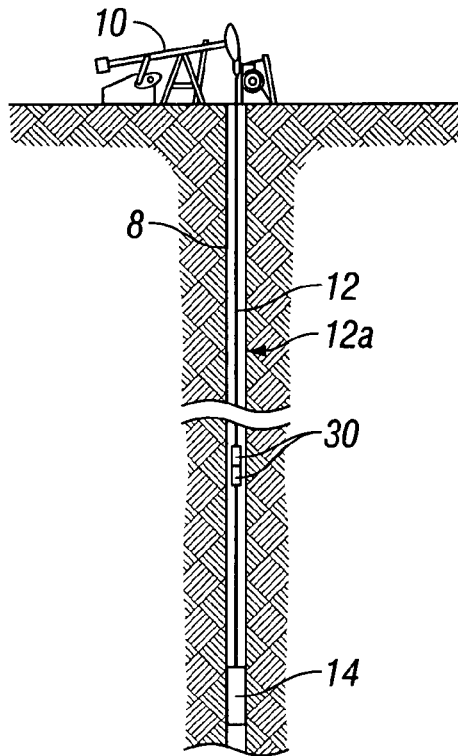

FIG. 1A

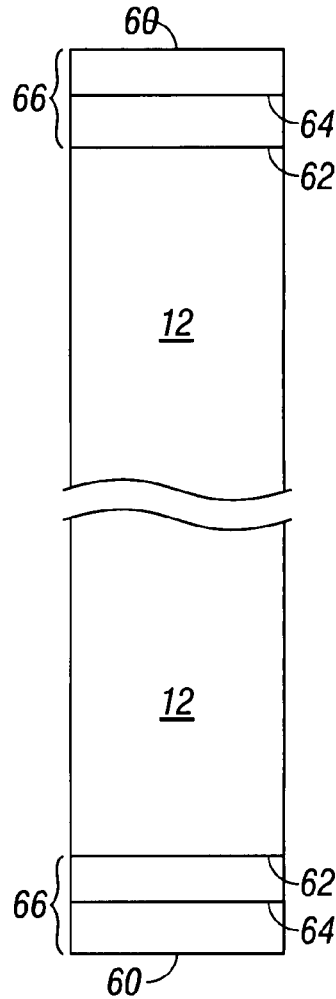
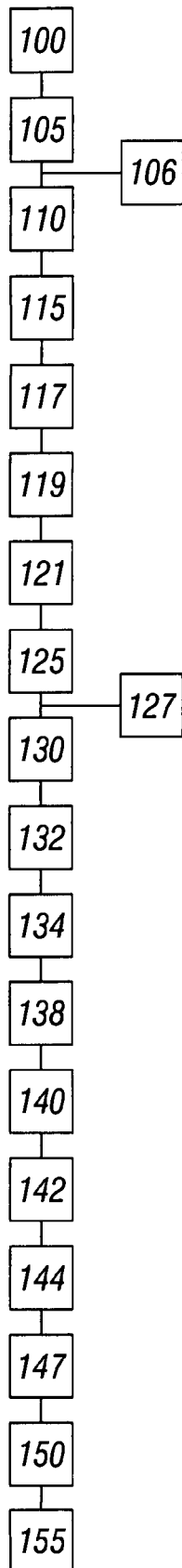

FIG. 3

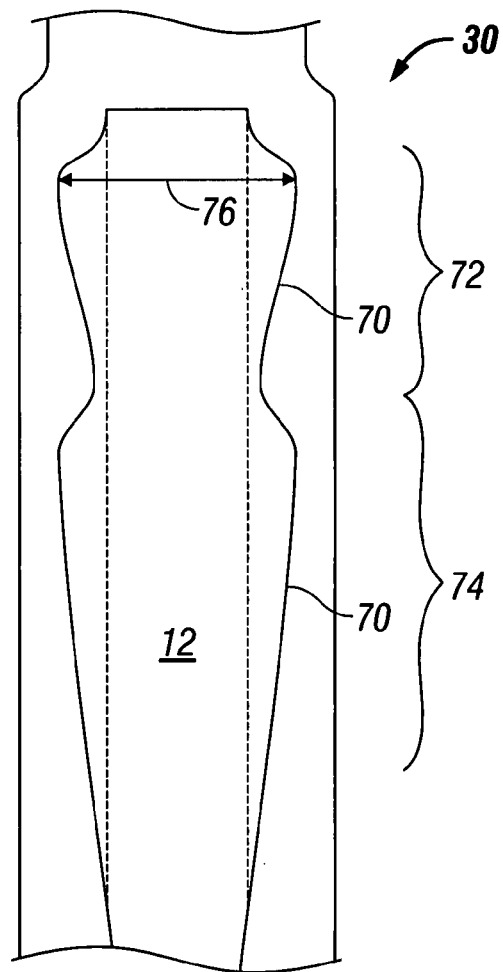
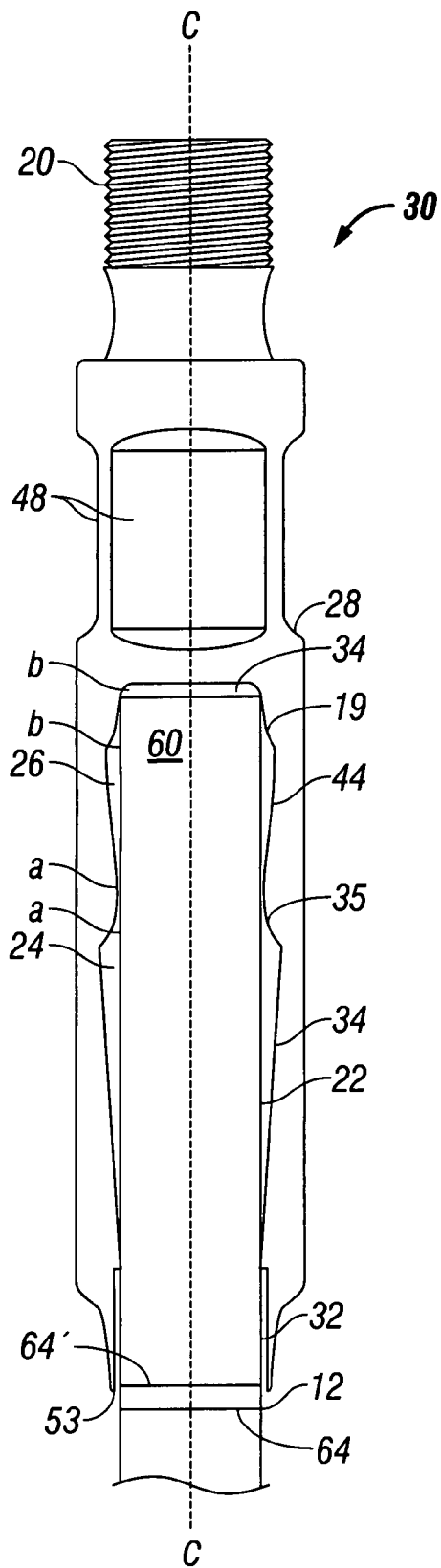

FIG. 4A

FIG. 4

Explore Litigation Insights

Docket Alarm provides insights to develop a more informed litigation strategy and the peace of mind of knowing you're on top of things.

Real-Time Litigation Alerts



Keep your litigation team up-to-date with **real-time alerts** and advanced team management tools built for the enterprise, all while greatly reducing PACER spend.

Our comprehensive service means we can handle Federal, State, and Administrative courts across the country.

Advanced Docket Research



With over 230 million records, Docket Alarm's cloud-native docket research platform finds what other services can't. Coverage includes Federal, State, plus PTAB, TTAB, ITC and NLRB decisions, all in one place.

Identify arguments that have been successful in the past with full text, pinpoint searching. Link to case law cited within any court document via Fastcase.

Analytics At Your Fingertips



Learn what happened the last time a particular judge, opposing counsel or company faced cases similar to yours.

Advanced out-of-the-box PTAB and TTAB analytics are always at your fingertips.

API

Docket Alarm offers a powerful API (application programming interface) to developers that want to integrate case filings into their apps.

LAW FIRMS

Build custom dashboards for your attorneys and clients with live data direct from the court.

Automate many repetitive legal tasks like conflict checks, document management, and marketing.

FINANCIAL INSTITUTIONS

Litigation and bankruptcy checks for companies and debtors.

E-DISCOVERY AND LEGAL VENDORS

Sync your system to PACER to automate legal marketing.