



US007031335B1

(12) **United States Patent**  
**Donohue et al.**

(10) **Patent No.:** **US 7,031,335 B1**  
(45) **Date of Patent:** **\*Apr. 18, 2006**

(54) **DIGITAL NODE FOR HYBRID FIBER/COAX NETWORK**

5,138,440 A 8/1992 Radice  
5,198,989 A 3/1993 Petroff  
5,272,700 A \* 12/1993 Hansen et al. .... 370/480

(75) Inventors: **John E. Donohue**, Ridgefield, CT (US); **Aravanan Gurusami**, Wallingford, CT (US); **Clarke V. Greene**, Middletown, CT (US)

(Continued)

**FOREIGN PATENT DOCUMENTS**

EP 0 664 621 7/1994

(Continued)

**OTHER PUBLICATIONS**

“Broadband Medium Attachment Unit and Broadband Medium Specification, Type 10BROAD36” *ANS/IEEE Std. 802.3, 177-205*, (1996).

(Continued)

(73) Assignee: **ADC Telecommunications, Inc.**, Minnetonka, MN (US)

(\* ) Notice: Subject to any disclaimer, the term of this patent is extended or adjusted under 35 U.S.C. 154(b) by 0 days.

This patent is subject to a terminal disclaimer.

*Primary Examiner*—Huy D. Vu  
*Assistant Examiner*—Daniel Ryman  
(74) *Attorney, Agent, or Firm*—Fogg and Associates LLC; David N. Fogg

(21) Appl. No.: **09/432,558**

(22) Filed: **Nov. 3, 1999**

(51) **Int. Cl.**  
**H04L 12/413** (2006.01)

(52) **U.S. Cl.** ..... **370/445; 370/481**

(58) **Field of Classification Search** ..... 714/746;  
348/476, 14.01; 370/480, 328, 438, 315,  
370/442; 359/167; 340/310.06; 333/103  
See application file for complete search history.

(57) **ABSTRACT**

An optical distribution node is provided. The optical distribution node includes a laser transceiver that is coupleable to at least one fiber optic link. The optical distribution node communicates upstream and downstream digital data with the head end over the at least one fiber optic link. The optical distribution node further includes a data concentrator coupled to the laser transceiver. Further, for each of at least one coaxial cable link, the optical distribution node includes a frequency translator and a node modem. The frequency translator receives and translates the upstream digital data from modems on the at least one coaxial cable link to a different carrier to provide a signal to the modems on the at least one coaxial cable link for collision detection. The node modem is coupled between the coaxial cable link and the data concentrator. The node modem demodulates upstream digital data for the data concentrator and modulates downstream digital data for transmission over the coaxial cable link.

(56) **References Cited**

**U.S. PATENT DOCUMENTS**

- 3,931,473 A 1/1976 Ferris, Jr.
- 3,995,144 A 11/1976 Johnson et al.
- 4,112,488 A 9/1978 Smith, III
- 4,244,046 A 1/1981 Brouard et al.
- 4,354,167 A \* 10/1982 Terreault et al. .... 333/103
- 4,402,076 A 8/1983 Krajewski
- 4,531,239 A 7/1985 Usui
- 4,754,451 A 6/1988 Eng et al.
- 4,816,825 A \* 3/1989 Chan et al. .... 340/825.5
- 4,920,533 A 4/1990 Dufresne et al.
- 4,959,829 A \* 9/1990 Griesing ..... 370/315
- 5,136,410 A 8/1992 Heiling et al.

**46 Claims, 3 Drawing Sheets**

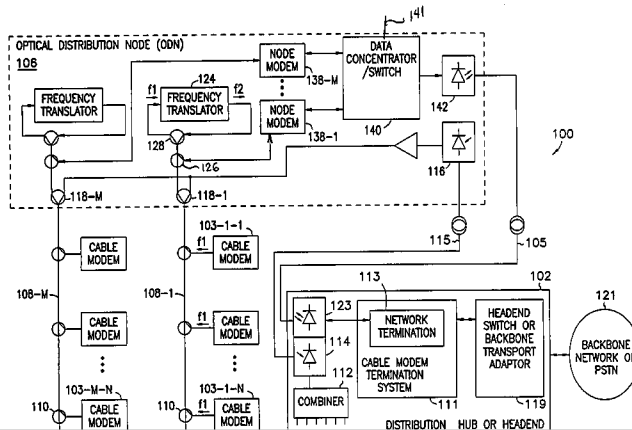

U.S. PATENT DOCUMENTS

|           |      |         |                       |            |
|-----------|------|---------|-----------------------|------------|
| 5,341,216 | A    | 8/1994  | Hoffart               |            |
| 5,442,700 | A *  | 8/1995  | Snell et al. ....     | 359/167    |
| 5,469,495 | A *  | 11/1995 | Beveridge .....       | 333/103    |
| 5,469,545 | A    | 11/1995 | Vanbuskirk et al.     |            |
| 5,557,319 | A    | 9/1996  | Gurusami et al. ....  | 348/11     |
| 5,586,121 | A *  | 12/1996 | Moura et al. ....     | 370/404    |
| 5,587,734 | A    | 12/1996 | Lauder et al.         |            |
| 5,621,786 | A    | 4/1997  | Fischer et al.        |            |
| 5,630,204 | A *  | 5/1997  | Hylton et al. ....    | 370/328    |
| 5,631,757 | A    | 5/1997  | Bodeep et al.         |            |
| 5,680,130 | A    | 10/1997 | Tsutsui et al.        |            |
| 5,729,370 | A    | 3/1998  | Bernstein et al.      |            |
| 5,754,552 | A *  | 5/1998  | Allmond et al. ....   | 370/465    |
| 5,765,097 | A    | 6/1998  | Dail                  |            |
| 5,765,099 | A    | 6/1998  | Georges et al.        |            |
| 5,768,682 | A *  | 6/1998  | Peyrovian .....       | 348/14.01  |
| 5,774,789 | A    | 6/1998  | Van der Kaay et al.   |            |
| 5,777,544 | A    | 7/1998  | Vander Mey et al.     |            |
| 5,790,806 | A    | 8/1998  | Koperda               |            |
| 5,828,677 | A    | 10/1998 | Sayeed et al.         |            |
| 5,838,989 | A    | 11/1998 | Hutchison et al.      |            |
| 5,859,895 | A *  | 1/1999  | Pomp et al. ....      | 340/310.06 |
| 5,864,672 | A    | 1/1999  | Bodeep et al.         |            |
| 5,864,748 | A *  | 1/1999  | Dail .....            | 725/126    |
| 5,867,485 | A    | 2/1999  | Chambers et al.       |            |
| 5,872,810 | A    | 2/1999  | Philips et al.        |            |
| 5,878,325 | A    | 3/1999  | Dail                  |            |
| 5,930,262 | A *  | 7/1999  | Sierens et al. ....   | 370/442    |
| 5,946,622 | A    | 8/1999  | Bojeryd               |            |
| 5,963,844 | A    | 10/1999 | Dail .....            | 455/5.1    |
| 5,986,691 | A *  | 11/1999 | Henderson .....       | 348/476    |
| 5,987,061 | A    | 11/1999 | Chen                  |            |
| 6,112,086 | A *  | 8/2000  | Wala .....            | 370/438    |
| 6,148,006 | A *  | 11/2000 | Dyke et al. ....      | 370/480    |
| 6,163,537 | A    | 12/2000 | Thacker               |            |
| 6,181,687 | B1 * | 1/2001  | Bisdikian .....       | 370/347    |
| 6,282,683 | B1 * | 8/2001  | Dapper et al. ....    | 714/746    |
| 6,356,369 | B1   | 3/2002  | Farhan                |            |
| 6,377,782 | B1   | 4/2002  | Bishop et al.         |            |
| 6,480,748 | B1 * | 11/2002 | Gerszberg et al. .... | 700/21     |

6,490,727 B1 12/2002 Nazarathy et al.

FOREIGN PATENT DOCUMENTS

|    |             |        |
|----|-------------|--------|
| EP | 0 727 883   | 8/1996 |
| WO | WO 96/24989 | 8/1996 |

OTHER PUBLICATIONS

“Scientific-Atlanta Announces New Technology To Enable High-Capacity Digital Reverse Path For Interactive Service”, <http://www.sciatl.com>, *Scientific-Atlanta, Inc., Norcross, GA*, 1-2, (Jan. 18, 1999).

Sniezko, O., “Reverse Path for Advanced Series—Architecture and Technology”, *NCTA Technical Papers*, AT&T Broadband & Internet Services, 11-19, (1999).

Sniezko, O., et al., “HFC Architecture in the Making”, *NCTA Technical Papers*, AT&T Broadband & Internet Services, 20-29, (1999).

Akos et al., Jul. 1999, *IEEE Transactions on Communications*, 47:983-988, “Direct Bandpass Sampling of Multiple Distinct RF Signals”.

Nakatsugawa et al., 2000, *IEEE*, pp. 617-621, “Software Radio Base and Personal Stations for Cellular/PCS Systems”.

1998, Foxcom Wireless Proprietary Information, pp. 1-8, “Litenna In-Building RF Distribution System”.

1998, Foxcom Wireless Proprietary Information, pp. 3-11, “Application Note Rfiber-RF Fiberoptic Links for Wireless Applications”.

“Creating a Network for Interactivity”, *IEEE Spectrum*, IEEE Inc., New York, US, vol.32, No. 4, Apr. 1995, pp 58-63, XP000506858, ISSN: 0018-9235.

“Adaptive Digital Access Protocol: A MAC Protocol for Multiservice Broadband Access Networks,” Dail et al, *IEEE Communications Magazine*, 34(3), 104-112, Mar. 1, 1996.

\* cited by examiner



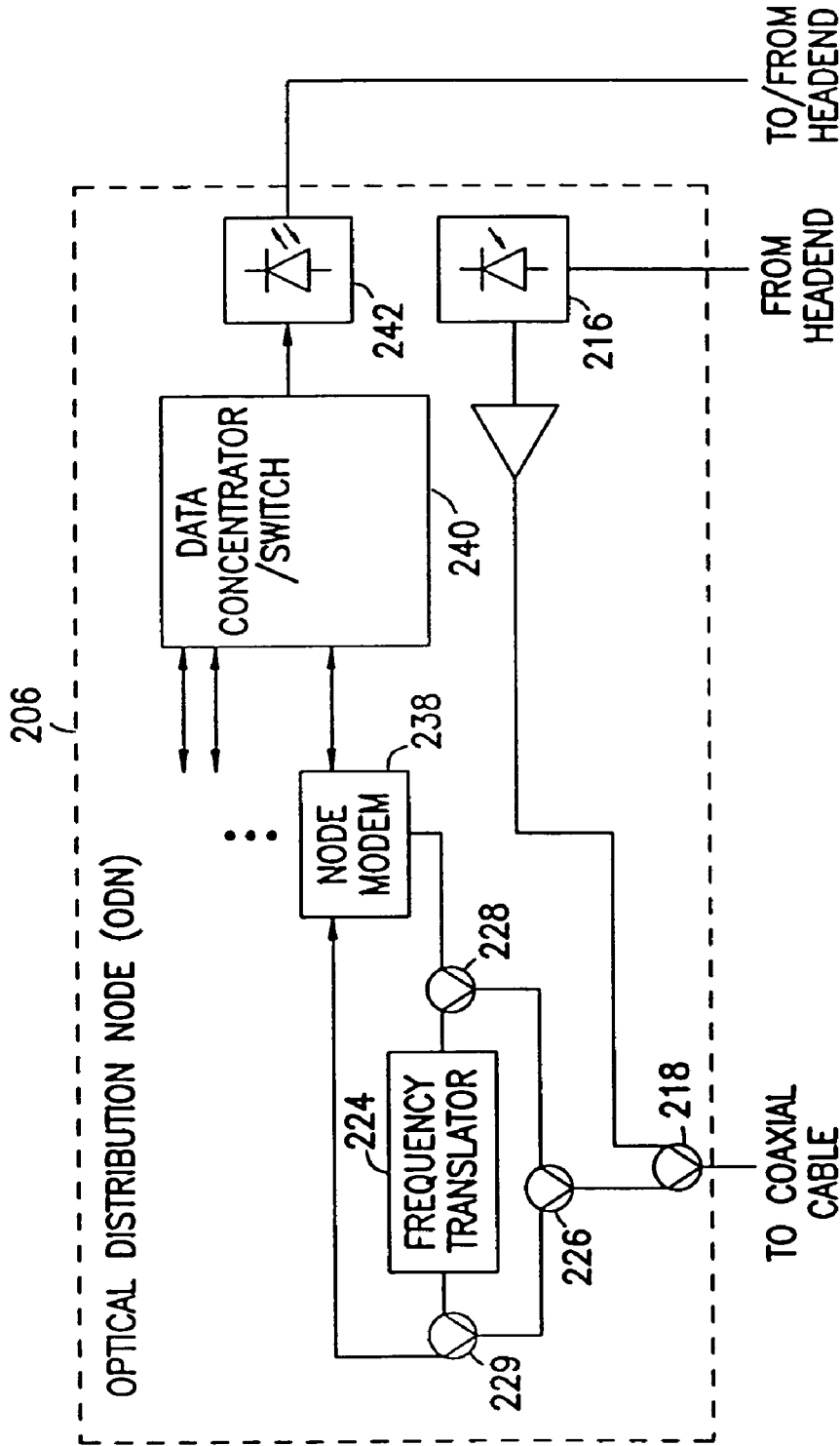

FIG. 2

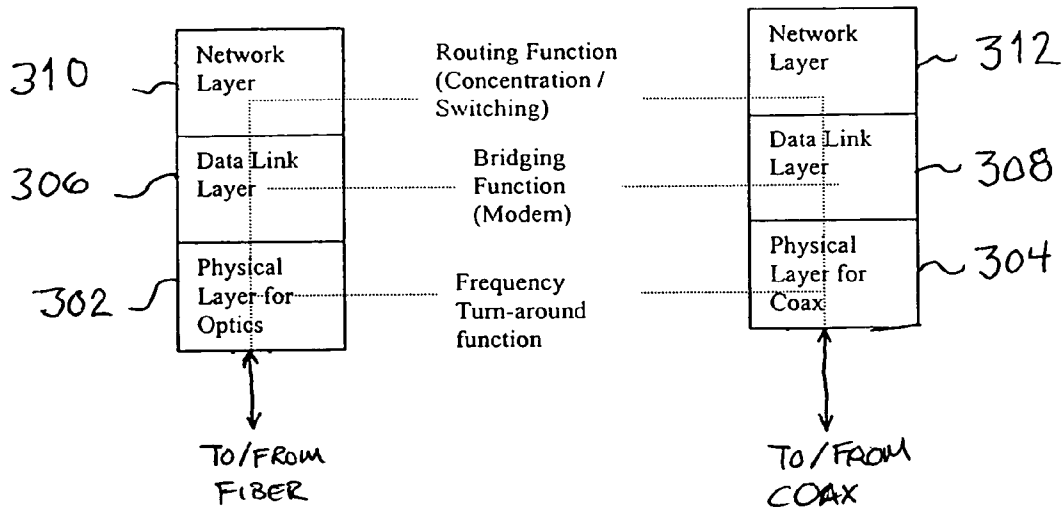

FIG. 3

# Explore Litigation Insights

Docket Alarm provides insights to develop a more informed litigation strategy and the peace of mind of knowing you're on top of things.

## Real-Time Litigation Alerts



Keep your litigation team up-to-date with **real-time alerts** and advanced team management tools built for the enterprise, all while greatly reducing PACER spend.

Our comprehensive service means we can handle Federal, State, and Administrative courts across the country.

## Advanced Docket Research



With over 230 million records, Docket Alarm's cloud-native docket research platform finds what other services can't. Coverage includes Federal, State, plus PTAB, TTAB, ITC and NLRB decisions, all in one place.

Identify arguments that have been successful in the past with full text, pinpoint searching. Link to case law cited within any court document via Fastcase.

## Analytics At Your Fingertips



Learn what happened the last time a particular judge, opposing counsel or company faced cases similar to yours.

Advanced out-of-the-box PTAB and TTAB analytics are always at your fingertips.

## API

Docket Alarm offers a powerful API (application programming interface) to developers that want to integrate case filings into their apps.

## LAW FIRMS

Build custom dashboards for your attorneys and clients with live data direct from the court.

Automate many repetitive legal tasks like conflict checks, document management, and marketing.

## FINANCIAL INSTITUTIONS

Litigation and bankruptcy checks for companies and debtors.

## E-DISCOVERY AND LEGAL VENDORS

Sync your system to PACER to automate legal marketing.