

UNITED STATES PATENT AND TRADEMARK OFFICE

---

BEFORE THE PATENT TRIAL AND APPEAL BOARD

---

SPRINGPATH, INC.,  
Petitioner,

v.

SIMPLIVITY CORPORATION,  
Patent Owner.

---

Case IPR2016-01780  
Patent 8,478,799 B2

---

Before KRISTEN L. DROESCH, KALYAN K. DESHPANDE, and  
MICHAEL J. FITZPATRICK, *Administrative Patent Judges*.

DROESCH, *Administrative Patent Judge*.

DECISION

Denying Institution of *Inter Partes* Review  
35 U.S.C. § 314, 37 C.F.R. § 42.108

## I. INTRODUCTION

### A. Background

Springpath, Inc. (“Petitioner”) filed a Petition (Paper 3, “Pet.”) for *inter partes* review of claims 1, 2, 7–13, 17–20, 27, and 33–35 (“the challenged claims”) of U.S. Patent No. 8,478,799 B2 (“the ’799 Patent”). See 35 U.S.C. §§ 311–312. SimpliVity Corporation (“Patent Owner”) timely filed a Preliminary Response (Paper 8, “Prelim. Resp.”). See 35 U.S.C. § 313.

We have authority under 35 U.S.C. § 314 and 37 C.F.R. § 42.4. An *inter partes* review may not be instituted unless it is determined that “the information presented in the petition filed under section 311 and any response filed under section 313 shows that there is a reasonable likelihood that the petitioner would prevail with respect to at least 1 of the claims challenged in the petition.” 35 U.S.C. § 314(a).

After considering the Petition and Preliminary Response, for the reasons provided below, we determine, based on the record before us, that there is not a reasonable likelihood Petitioner would prevail in showing any of claims 1, 2, 7–13, 17–20, 27, and 33–35 is unpatentable.

### B. Related Proceedings

The parties indicate the ’799 Patent is involved in the following related matters:

*SimpliVity Corp. v. Springpath, Inc.*, Case No. 4:15-cv-13345-TSH (D. Mass); and

Petition for *inter partes* review in Case No. IPR2016-01779 (concurrently filed). Pet. 3; Paper 6, 1.

C. The '799 Patent (Ex. 1101)

The '799 Patent discloses computer file system data structures and methods and apparatus for naming and storing files. See Ex. 1101, 1:4–6.

Figure 1 of the '799 Patent is reproduced below:

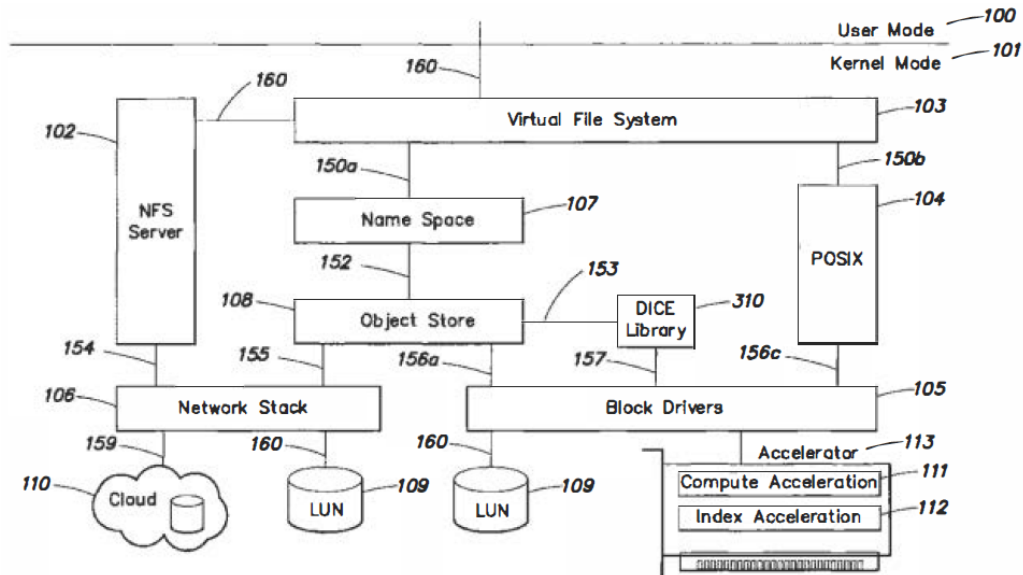

Figure 1 depicts various storage components in operating system kernel 101. See Ex. 1101, 10:25–26. POSIX® file system 104, Network File System (NFS) 102, and a new file system composed of namespace file system 107 stacked on top of lightweight object file system 108 connected to virtual file system (VFS) 103. See *id.* at 10:30–38, 63–65. The new file system works alongside other file systems in kernel 101, and many file systems typically work in parallel. See *id.* at 10:38–39, 46–47. VFS 103 is used to abstract out common features of the file systems and provide a consistent user interface 160 to user 100. See *id.* at 10:33–39. “File systems normally sit on top of a block storage abstraction, implemented by block drivers 105. The block storage may be on a Logical Unit Number LUN storage device 109, or it may be on a remote LUN.” *Id.* at 10:40–44. Object file system or object store 108 creates an object container that may sit on top of a raw LUN, a

partition on a disk, or a large file. *See id.* at 10:59–61. Object store 108 may reference containers via network stack 106. *See id.* at 10:61–63. NFS 102 sits on top of network stack 106, and network stack 106 is connected to LUN 109 and Cloud 110. *See id.* at 10:63–67.

Figure 2 of the '799 Patent is reproduced below:

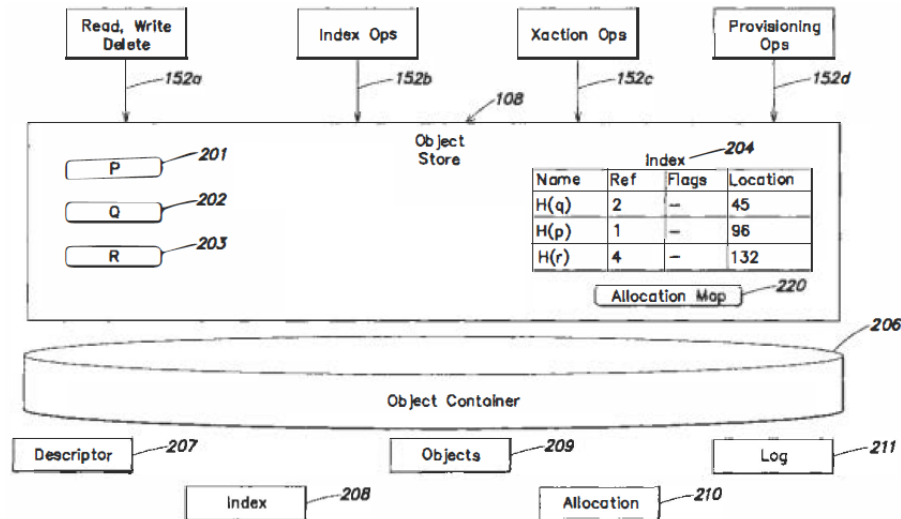

Figure 2 depicts object store 108 of Figure 1 and various components. *See* Ex. 1101, 5:4–6, 11:1–2. Object store 108 contains binary, opaque objects P 201, Q 202, and R 203. An object can be of varying size, and resides at some offset in object container 206. *See id.* at 11: 3–9. Each object has a name or fingerprint (e.g., H(q), H(p), H(r)) which is a cryptographic digest or hash of the object's entire content. *See id.* at 11:10–13. Index 204 keeps track of object names, object locations, and object references. *See id.* at 11:14–15. There is an index entry for every object in the system, each entry containing a fingerprint of the object's content, a reference count, physical locator (e.g., logical block number, reference to cloud object), and flags. *See id.* at 11:40–61. Object container 206 is a randomly addressable persistent

storage abstraction, such as a raw LUN, a file, a partition on a disk, or a device across a Wide Area Network. *See id.* at 11:64–67.

Figure 4 of the '799 Patent is reproduced below:

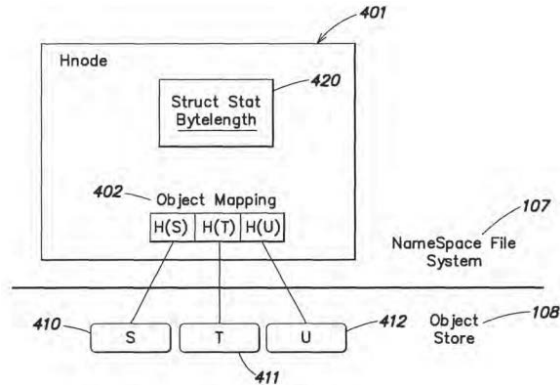

Figure 4 depicts a set of objects grouped together in a hnode. *See Ex. 1101, 7:13–15, 12:51–52.* Hnode 401 is a sequence of content, like a file that can be read, written, appended to, created deleted and truncated. *See id.* at 12:55–57. The data sequence is broken into discrete objects (e.g., S 401, T 411, U 412) where the names of each object are stored in mapping table 402 which records the fingerprints (e.g., H(S), H(T), H(U)) of each object. *See id.* at 12:63–66. Hnode 401 is an object itself. *See id.* at 13:8.

Figure 5 of the '799 Patent is reproduced below:

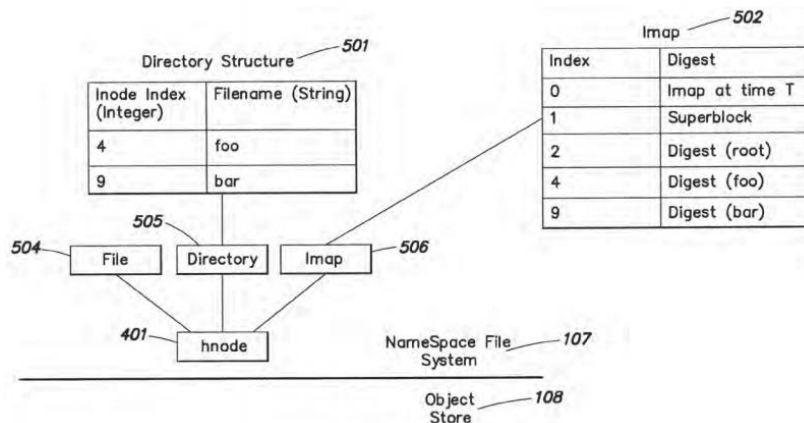

Figure 5 depicts a hnode specialized into files, directories, and imaps. *See Ex. 1101, 6:16–18.* Directory 505 is a mapping of inode numbers to file

# Explore Litigation Insights

Docket Alarm provides insights to develop a more informed litigation strategy and the peace of mind of knowing you're on top of things.

## Real-Time Litigation Alerts



Keep your litigation team up-to-date with **real-time alerts** and advanced team management tools built for the enterprise, all while greatly reducing PACER spend.

Our comprehensive service means we can handle Federal, State, and Administrative courts across the country.

## Advanced Docket Research



With over 230 million records, Docket Alarm's cloud-native docket research platform finds what other services can't. Coverage includes Federal, State, plus PTAB, TTAB, ITC and NLRB decisions, all in one place.

Identify arguments that have been successful in the past with full text, pinpoint searching. Link to case law cited within any court document via Fastcase.

## Analytics At Your Fingertips



Learn what happened the last time a particular judge, opposing counsel or company faced cases similar to yours.

Advanced out-of-the-box PTAB and TTAB analytics are always at your fingertips.

## API

Docket Alarm offers a powerful API (application programming interface) to developers that want to integrate case filings into their apps.

## LAW FIRMS

Build custom dashboards for your attorneys and clients with live data direct from the court.

Automate many repetitive legal tasks like conflict checks, document management, and marketing.

## FINANCIAL INSTITUTIONS

Litigation and bankruptcy checks for companies and debtors.

## E-DISCOVERY AND LEGAL VENDORS

Sync your system to PACER to automate legal marketing.