



# United States Patent [19]

[11] **Patent Number:** 5,488,204

**Mead et al.**

[45] **Date of Patent:** Jan. 30, 1996

[54] **PAINTBRUSH STYLUS FOR CAPACITIVE TOUCH SENSOR PAD**

5,369,227	11/1994	Stone	.....	178/18
5,373,118	12/1994	Uktsen	.....	178/18 X
5,408,593	4/1995	Kotaki et al.	.....	395/122

[75] **Inventors:** Carver A. Mead, Pasadena; Ralph Wolf, Palo Alto; Timothy P. Allen, Los Gatos, all of Calif.

*Primary Examiner*—Stephen Chin  
*Assistant Examiner*—Paul Loomis  
*Attorney, Agent, or Firm*—D'Alessandro & Ritchie

[73] **Assignee:** Synaptics, Incorporated, San Jose, Calif.

[21] **Appl. No.:** 324,438

[57] **ABSTRACT**

[22] **Filed:** Oct. 17, 1994

A proximity sensor system includes a touch-sensor pad with a sensor matrix array having a characteristic capacitance on horizontal and vertical conductors connected to sensor pads. The capacitance changes as a function of the proximity of an object or objects to the sensor matrix. The change in capacitance of each node in both the X and Y directions of the matrix due to the approach of an object is converted to a set of voltages in the X and Y directions. These voltages are processed by circuitry to develop electrical signals representative of the centroid of the profile of the object, i.e., its position in the X and Y dimensions. Noise reduction and background level setting techniques inherently available in the architecture are employed. A conductive paintbrush-type stylus is used to produce paint-like strokes on a display associated with the touch-sensor pad.

**Related U.S. Application Data**

[63] Continuation-in-part of Ser. No. 300,630, Sep. 2, 1994, which is a continuation-in-part of Ser. No. 300,387, Sep. 2, 1994, which is a continuation-in-part of Ser. No. 115,743, Aug. 31, 1993, Pat. No. 5,374,787, which is a continuation-in-part of Ser. No. 895,934, Jun. 8, 1992, abandoned.

[51] **Int. Cl.<sup>6</sup>** ..... **G08C 21/00**

[52] **U.S. Cl.** ..... **178/18; 345/179**

[58] **Field of Search** ..... 178/12, 19, 20, 178/87; 345/173, 174, 175, 179, 180, 181; 341/5; 382/3, 13; 355/27, 266; 395/117, 118, 122

[56] **References Cited**

**U.S. PATENT DOCUMENTS**

5,231,450 7/1993 Daniels ..... 355/27

**11 Claims, 17 Drawing Sheets**

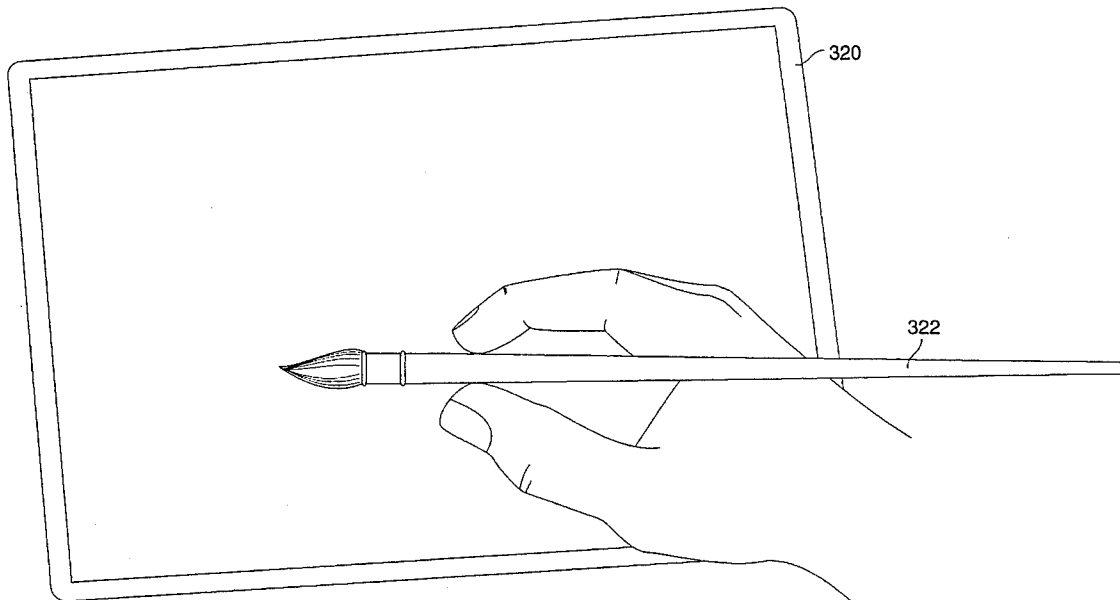

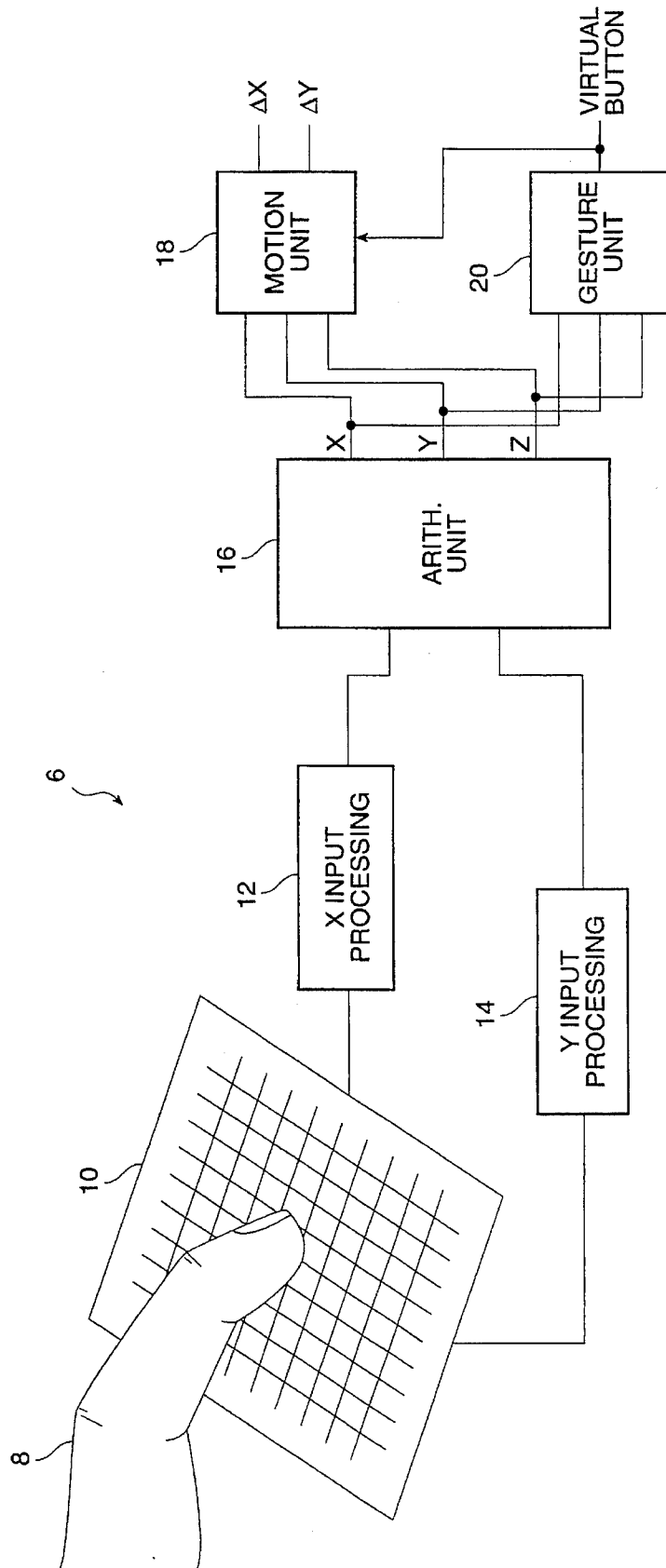

FIG. 1

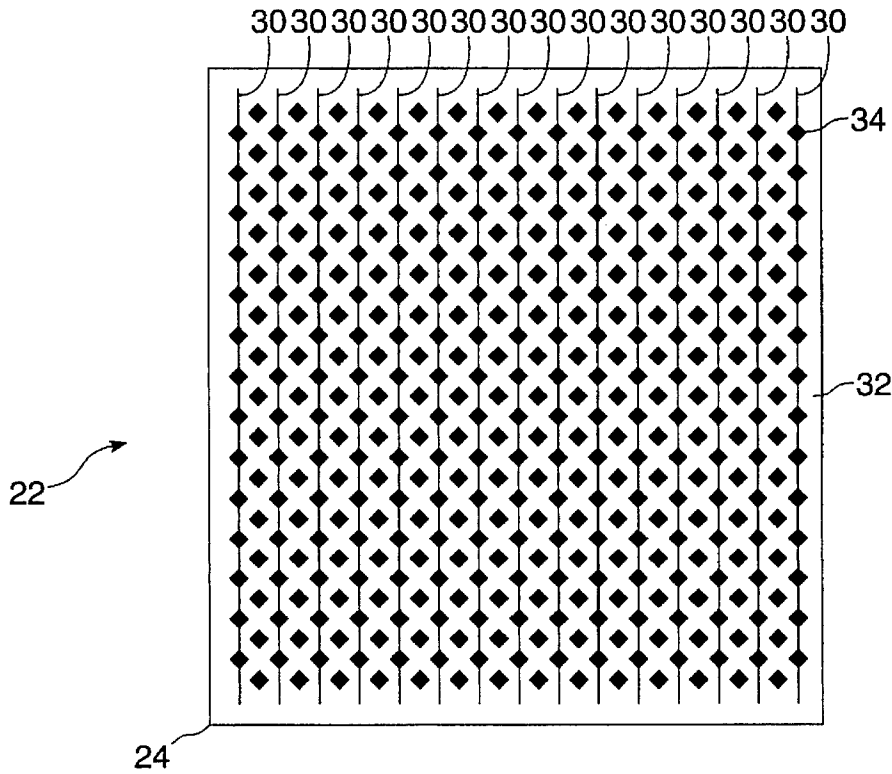

FIG. 2A

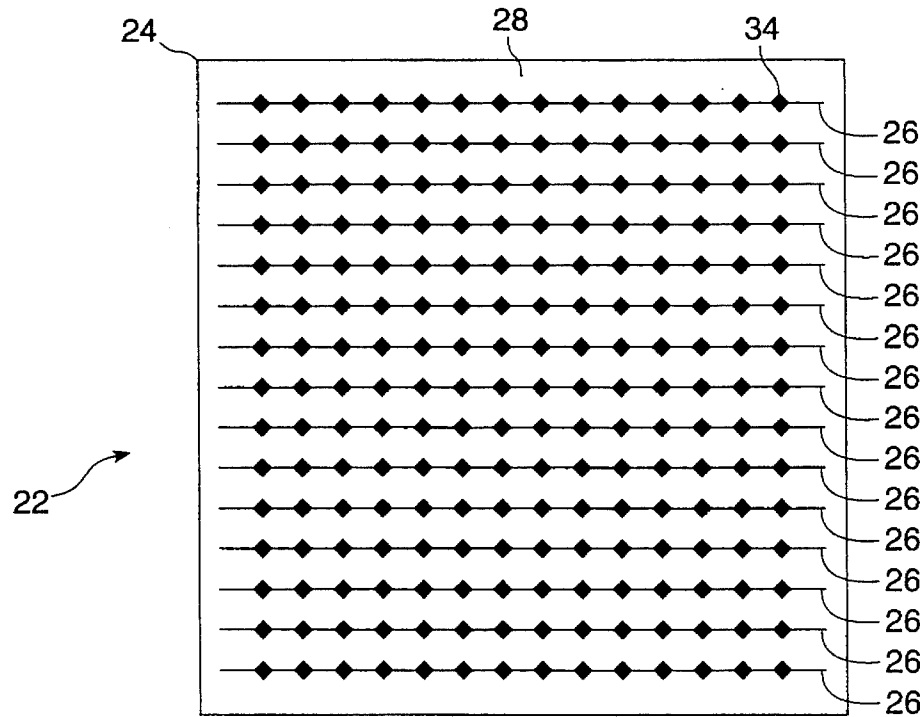

FIG. 2B

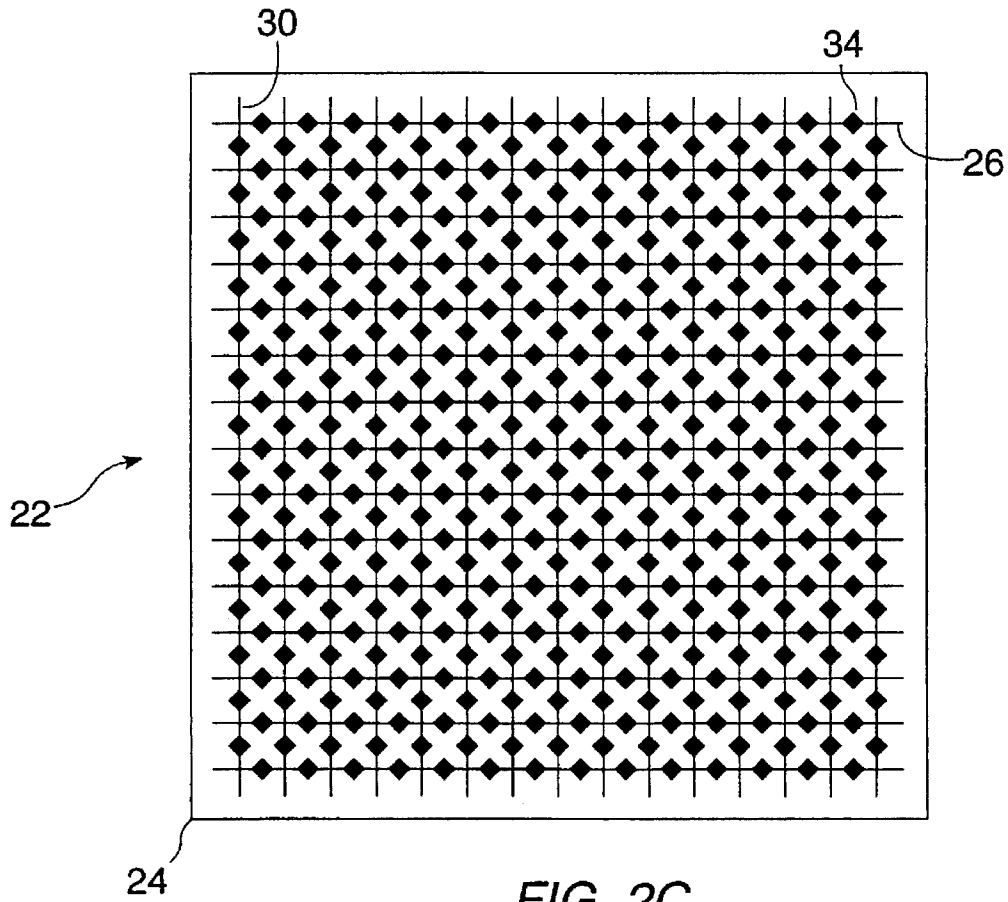

FIG. 2C

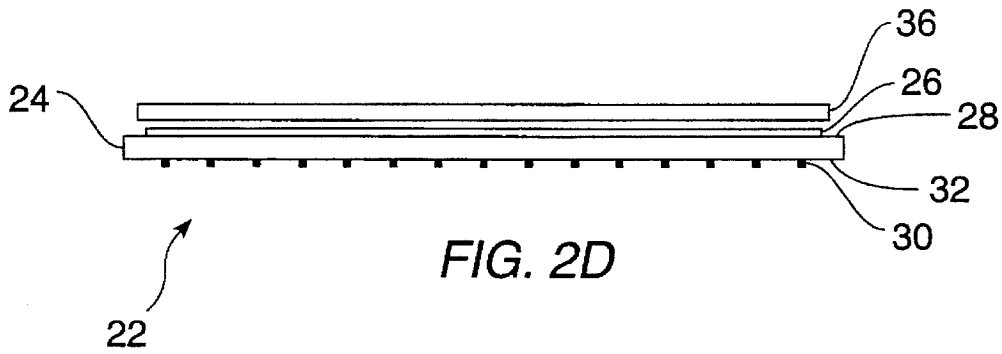

FIG. 2D

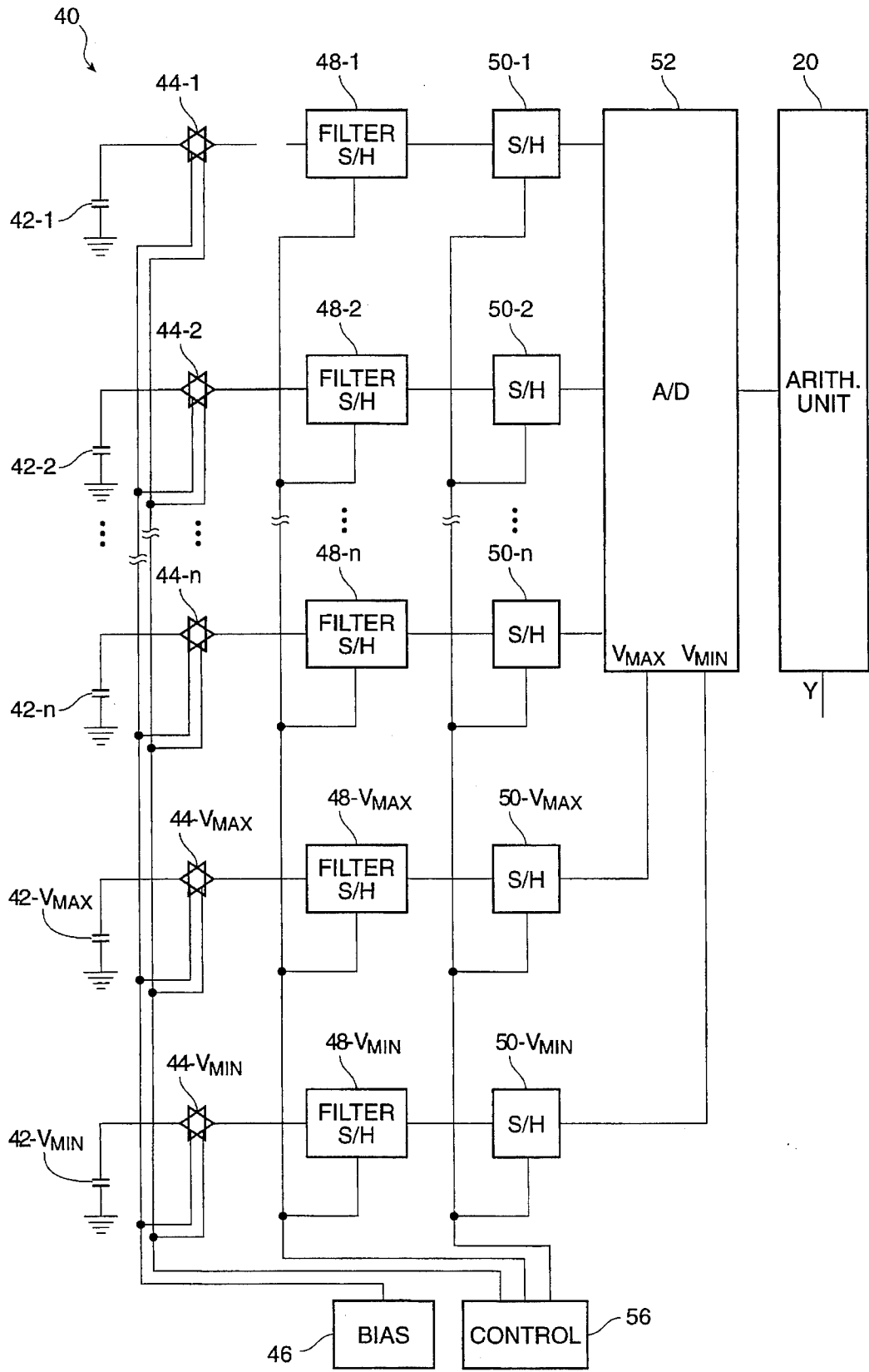

FIG. 3

# Explore Litigation Insights

Docket Alarm provides insights to develop a more informed litigation strategy and the peace of mind of knowing you're on top of things.

## Real-Time Litigation Alerts



Keep your litigation team up-to-date with **real-time alerts** and advanced team management tools built for the enterprise, all while greatly reducing PACER spend.

Our comprehensive service means we can handle Federal, State, and Administrative courts across the country.

## Advanced Docket Research



With over 230 million records, Docket Alarm's cloud-native docket research platform finds what other services can't. Coverage includes Federal, State, plus PTAB, TTAB, ITC and NLRB decisions, all in one place.

Identify arguments that have been successful in the past with full text, pinpoint searching. Link to case law cited within any court document via Fastcase.

## Analytics At Your Fingertips



Learn what happened the last time a particular judge, opposing counsel or company faced cases similar to yours.

Advanced out-of-the-box PTAB and TTAB analytics are always at your fingertips.

## API

Docket Alarm offers a powerful API (application programming interface) to developers that want to integrate case filings into their apps.

## LAW FIRMS

Build custom dashboards for your attorneys and clients with live data direct from the court.

Automate many repetitive legal tasks like conflict checks, document management, and marketing.

## FINANCIAL INSTITUTIONS

Litigation and bankruptcy checks for companies and debtors.

## E-DISCOVERY AND LEGAL VENDORS

Sync your system to PACER to automate legal marketing.