

**Table 25-2—UTP MDI contact assignments**

CONTACT	PHY without internal crossover MDI SIGNAL	PHY with internal crossover MDI SIGNAL
1	Transmit +	Receive +
2	Transmit –	Receive –
3	Receive +	Transmit +
4		
5		
6	Receive –	Transmit –
7		
8		

**25.4.6 Replacement of 11.2, “Crossover function”**

Clause 11.2 of TP-PMD is replaced with the following:

A crossover function compliant with 14.5.2 shall be implemented except that a) the signal names are those used in TP-PMD, and b) the contact assignments for STP are those shown in table 8-2 of TP-PMD. Note that compliance with 14.5.2 implies a recommendation that crossover (for both UTP and STP) be performed within repeater PHYs.

**25.4.7 Change to A.2, “DDJ test pattern for baseline wander measurements”**

The length of the test pattern specified in TP-PMD annex A.2 may be shortened to accommodate feasible 100BASE-X measurements, but shall not be shorter than 3000 code-groups.

NOTE—This pattern is to be applied to the MII. (When applied to the MAC, the nibbles within each byte are to be swapped. E.g., as delivered to the MAC, the test pattern would start, "60 c9 16 ...".)

**25.4.8 Change to annex G, “Stream cipher scrambling function”**

An example of a stream cipher scrambling implementation is shown in TP-PMD annex G. This may be modified to allow synchronization solely on the IDLE sequences between packets.

**25.4.9 Change to annex I, “Common mode cable termination”**

The contact assignments shown in TP-PMD figures I-1 and I-2 shall instead comply with those specified in table 25-2.

## 25.5 Protocol Implementation Conformance Statement (PICS) proforma for clause 25, Physical Medium Dependent (PMD) sublayer and baseband medium, type 100BASE-TX<sup>24</sup>

### 25.5.1 Introduction

The supplier of a protocol implementation that is claimed to conform to IEEE Std 802.3u-1995, Physical Medium Dependent (PMD) sublayer and baseband medium, type 100BASE-TX, shall complete the following Protocol Implementation Conformance Statement (PICS) proforma.

A detailed description of the symbols used in the PICS proforma, along with instructions for completing the PICS proforma, can be found in clause 21.

### 25.5.2 Identification

#### 25.5.2.1 Implementation identification

Supplier	
Contact point for enquiries about the PICS	
Implementation Name(s) and Version(s)	
Other information necessary for full identification—e.g., name(s) and version(s) for machines and/or operating systems; System Names(s)	
<p>NOTES</p> <p>1—Only the first three items are required for all implementations; other information may be completed as appropriate in meeting the requirements for the identification.</p> <p>2—The terms Name and Version should be interpreted appropriately to correspond with a supplier's terminology (e.g., Type, Series, Model).</p>	

#### 25.5.2.2 Protocol summary

Identification of protocol standard	IEEE Std 802.3u-1995, Physical Medium Dependent (PMD) sublayer and baseband medium, type 100BASE-TX
Identification of amendments and corrigenda to this PICS proforma that have been completed as part of this PICS	
Have any Exception items been required? (See clause 21; the answer Yes means that the implementation does not conform to IEEE Std 802.3u-1995.)	No [ ] Yes [ ]
Date of Statement	

<sup>24</sup>Copyright release for PICS proformas Users of this standard may freely reproduce the PICS proforma in this annex so that it can be used for its intended purpose and may further publish the completed PICS.

**25.5.3 Major capabilities/options**

Item	Feature	Subclause	Status	Support	Value/Comment
*TXU	Supports unshielded twisted pair	25.2	O/1		
TXS	Supports shielded twisted pair	25.2	O/1		

**25.5.4 PICS proforma tables for the Physical Medium Dependent (PMD) sublayer and base-band medium, type 100BASE-TX****25.5.4.1 General compatibility considerations**

Item	Feature	Subclause	Status	Support	Value/Comment
GN1	Integrates 100BASE-X PMA and PCS	25.1	M		See clause 24

**25.5.4.2 PMD compliance**

Item	Feature	Subclause	Status	Support	Value/Comment
PD1	Compliance with 100BASE-X PMD Service Interface	25.1	M		See 24.2.3
PD2	Compliance with ANSI X3.237: 199X, 7, 8 (excluding 8.3), 9, 10, 11 and normative annex A, with listed exceptions	25.4 25.4.5	M		
PD3	Precedence over ANSI X3.237-199X	25.4	M		
PD4	MDI contact assignments for unshielded twisted pair	25.4.4 25.4.10	TXU: M		
PD5	Compliance with crossover function of 14.5.2 with listed adaptations	25.4.7	M		
PD6	Minimum jitter test pattern length	25.4.8	M		3000 code-groups

This is an Archive IEEE Standard. It has been superseded by a later version of this standard.

## 26. Physical Medium Dependent (PMD) sublayer and baseband medium, type 100BASE-FX

### 26.1 Overview

This clause specifies the 100BASE-X PMD (including MDI) and fiber optic medium for multi-mode fiber, 100BASE-FX. In order to form a complete 100BASE-FX Physical Layer it shall be integrated with the 100BASE-X PCS and PMA of clause 24, which are assumed incorporated by reference. As such, the 100BASE-FX PMD shall comply with the PMD service interface specified in 24.4.1.

### 26.2 Functional specifications

The 100BASE-FX PMD (and MDI) is specified by incorporating the FDDI PMD standard, ISO 9314-3: 1990, by reference, with the modifications noted below. This standard provides support for two optical fibers. For improved legibility in this clause, ISO 9314-3: 1990 will henceforth be referred to as fiber-PMD.

### 26.3 General exceptions

The 100BASE-FX PMD is precisely the PMD specified as fiber-PMD, with the following general modifications:

- a) The Scope and General description discussed in fiber-PMD 1 and 5 relate to the use of those standards with an FDDI PHY, ISO 9314-1: 1989, and MAC, ISO 9314-2: 1989. These clauses are not relevant to the use of the PMD with 100BASE-X.
- b) The Normative references, Definitions and Conventions of fiber-PMD 2, 3, and 4 are used only as necessary to interpret the applicable sections of fiber-PMD referenced in this clause.
- c) The PMD Service Specifications of fiber-PMD 6 are replaced by those specified in 24.4.1. The 100BASE-FX PMD Service specification is a proper subset of the PMD service specification in fiber-PMD.
- d) There are minor terminology differences between this standard and fiber-PMD that do not cause ambiguity. The terminology used in 100BASE-X was chosen to be consistent with other IEEE 802 standards, rather than with FDDI. Terminology is both defined and consistent within each standard. Special note should be made of the interpretations shown in table 26-1.

**Table 26-1—Interpretation of general FDDI terms and concepts**

FDDI term or concept	Interpretation for 100BASE-X
bypass	<unused>
Connection Management (CMT)	<no comparable entity>
frame	stream
Halt Line State (HLS)	<unused>
hybrid mode	<no comparable entity>
MAC (or MAC-2)	MAC
Master Line State (MLS)	<unused>
maximum frame size = 9000 symbols	maximum stream size = 3054 code-groups

**Table 26-1—Interpretation of general FDDI terms and concepts (Continued)**

FDDI term or concept	Interpretation for 100BASE-X
PHY (or PHY-2)	PMA; i.e., PMD client
PHY Service Data Unit (SDU)	stream
PM_SIGNAL.indication (Signal_Detect)	PMD_SIGNAL.indicate (signal_status)
PM_UNITDATA.indication (PM_Indication)	PMD_UNITDATA.indicate (nrzi-bit)
PM_UNITDATA request (PM_Request)	PMD_UNITDATA request (nrzi-bit)
preamble	inter-packet IDLEs
Quiet Line State (QLS)	<unused>
SM_PM_BYPASS request (Control_Action)	Assume: SM_PM_BYPASS request (Control_Action = Insert)
SM_PM_CONTROL request (Control_Action)	Assume: SM_PM_CONTROL request (Control_Action = Transmit_Enable)
SM_PM_SIGNAL.indication (Signal_Detect)	<unused>
Station Management (SMT)	<no comparable entity>
symbol	code-group

## 26.4 Specific requirements and exceptions

The 100BASE-FX PMD (including MDI) and baseband medium shall conform to the requirements of fiber-PMD 8, 9, and 10. In fiber-PMD, informative annexes A through G provide additional information useful to PMD sublayer implementors. Where there is conflict between specifications in fiber-PMD and those in this standard, those of this standard shall prevail.

### 26.4.1 Medium Dependent Interface (MDI)

The 100BASE-FX medium dependent interface (MDI) shall conform to one of the following connectors. The recommended alternative is the Low Cost Fibre Optical Interface Connector.

- a) Low Cost Fibre Optical Interface Connector (commonly called the duplex SC connector) as specified in ANSI X3.237-199X, 7.1.1 through 7.3.1, inclusive.
- b) Media Interface Connector (MIC) as specified in fiber-PMD 7 and annex F. When the MIC is used, the receptacle shall be keyed as “M”.
- c) Optical Medium Connector Plug and Socket (commonly called ST connector) as specified in 15.3.2.

### 26.4.2 Crossover function

A crossover function shall be implemented in every cable-pair link. The crossover function connects the transmitter of one PHY to the receiver of the PHY at the other end of the cable-pair link. For 100BASE-FX, the crossover function is realized in the cable plant.

## 26.5 Protocol Implementation Conformance Statement (PICS) proforma for clause 26, Physical Medium Dependent (PMD) sublayer and baseband medium, type 100BASE-FX<sup>25</sup>

### 26.5.1 Introduction

The supplier of a protocol implementation that is claimed to conform to IEEE Std 802.3u-1995, Physical Medium Dependent (PMD) sublayer and baseband medium, type 100BASE-FX, shall complete the following Protocol Implementation Conformance Statement (PICS) proforma.

A detailed description of the symbols used in the PICS proforma, along with instructions for completing the PICS proforma, can be found in clause 21.

### 26.5.2 Identification

#### 26.5.2.1 Implementation identification

Supplier	
Contact point for enquiries about the PICS	
Implementation Name(s) and Version(s)	
Other information necessary for full identification—e.g., name(s) and version(s) for machines and/or operating systems; System Names(s)	
<p>NOTES</p> <p>1—Only the first three items are required for all implementations; other information may be completed as appropriate in meeting the requirements for the identification.</p> <p>2—The terms Name and Version should be interpreted appropriately to correspond with a supplier's terminology (e.g., Type, Series, Model).</p>	

### 26.5.3 Protocol summary

Identification of protocol standard	IEEE Std 802.3u-1995, Physical Medium Dependent (PMD) sublayer and baseband medium, type 100BASE-FX
Identification of amendments and corrigenda to this PICS proforma that have been completed as part of this PICS	
Have any Exception items been required? (See clause 21; the answer Yes means that the implementation does not conform to IEEE Std 802.3u-1995.)	No [ ]    Yes [ ]
Date of Statement	

<sup>25</sup>Copyright release for PICS proformas Users of this standard may freely reproduce the PICS proforma in this annex so that it can be used for its intended purpose and may further publish the completed PICS.

### 26.5.4 Major capabilities/options

Item	Feature	Subclause	Status	Support	Value/Comment
FSC	Supports Low Cost Fibre Optical Interface Connector (duplex SC)	26.4.2	O/1		Recommended. See ANSI X3.237-199X, 7.1.1 through 7.3.1
*FMC	Supports Media Interface Connector (MIC)	26.4.2	O/1		See ISO 9314-3: 1990, 7 and annex F
FST	Supports Optical Medium Connector Plug and Socket (ST)	26.4.2	O/1		See 15.3.2

### 26.5.5 PICS proforma tables for Physical Medium Dependent (PMD) sublayer and baseband medium, type 100BASE-FX

#### 26.5.5.1 General compatibility considerations

Item	Feature	Subclause	Status	Support	Value/Comment
GN1	Integrates 100BASE-X PMA and PCS	26.1	M		See clause 24

#### 26.5.5.2 PMD compliance

Item	Feature	Subclause	Status	Support	Value/Comment
PD1	Compliance with 100BASE-X PMD Service Interface	26.1	M		See 24.2.3
PD2	Compliance with ISO 9314-3: 1990 8, 9, and 10	26.4	M		
PD3	Precedence over ISO 9314-3: 1990	26.4	M		
PD4	MIC receptacle keying	26.4.2	FMC: M		"M"
PD5	Crossover function in cable	26.4.3	M		



## 27. Repeater for 100 Mb/s baseband networks

### 27.1 Overview

#### 27.1.1 Scope

Clause 27 defines the functional and electrical characteristics of a repeater for use with 100BASE-T 100 Mb/s baseband networks. A repeater for any other ISO/IEC 8802-3 network type is beyond the scope of this clause. The relationship of this standard to the entire ISO/IEC 8802-3 CSMA/CD LAN standard is shown in figure 27-1. The purpose of the repeater is to provide a simple, inexpensive, and flexible means of coupling two or more segments.

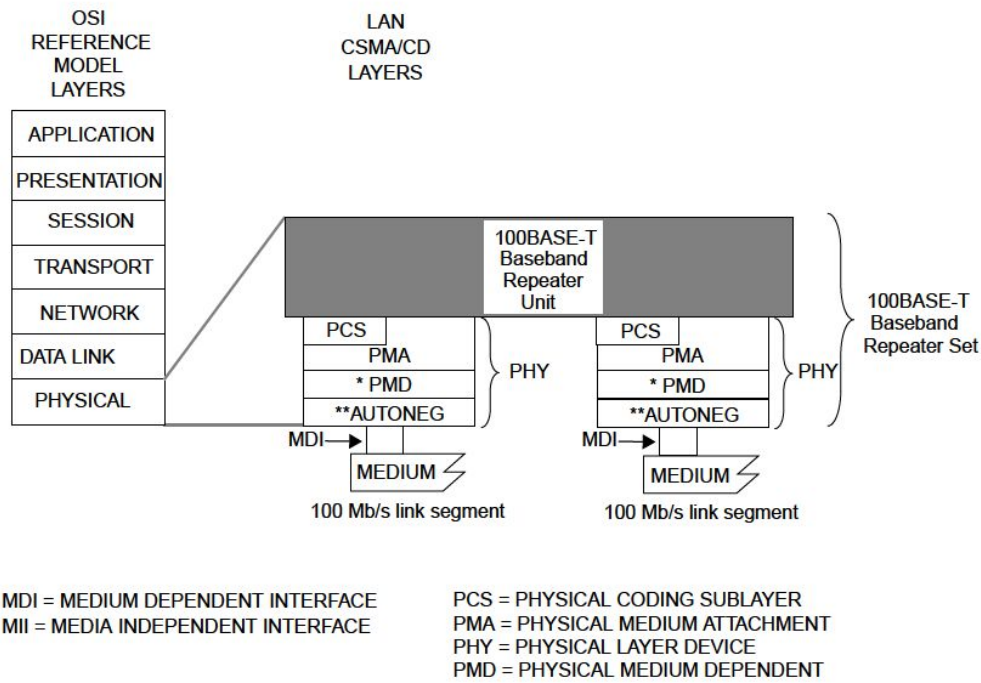

\* PMD is specified for 100BASE-TX and -FX only; 100BASE-T4 does not use this layer.  
Use of MII between PCS and baseband repeater unit is optional.  
\*\* AUTONEG is optional.

Figure 27-1—100BASE-T repeater set relationship to the OSI reference model

#### 27.1.1.1 Repeater set

Repeater sets are an integral part of all 100 Mb/s baseband networks with more than two DTEs and are used to extend the physical system topology by providing a means of coupling two or more segments. Multiple repeater sets are permitted within a single collision domain to provide the maximum connection path length. Segments may be connected directly by a repeater or a pair of repeaters that are, in turn, connected by a inter-repeater link (IRL). Allowable topologies shall contain only one operative signal path between any two points on the network. A repeater set is not a station and does not count toward the overall limit of 1024 stations on a network.

A repeater set can receive, and if necessary decode, data from any segment under worst-case noise, timing, and signal amplitude conditions. It retransmits the data to all other segments attached to it with timing, amplitude, and, if necessary, coding restored. The retransmission of data occurs simultaneously with reception. If a collision occurs, the repeater set propagates the collision event throughout the network by transmitting a Jam signal. A repeater set also provides a degree of protection to a network by isolating a faulty segment's carrier activity from propagating through the network.

#### **27.1.1.2 Repeater unit**

A repeater unit is a subset of a repeater set containing all the repeater-specific components and functions, exclusive of PHY components and functions. A repeater unit connects to the PMA and, if necessary, the PCS sublayers of its PHYs.

#### **27.1.1.3 Repeater classes**

Two classes of repeater sets are defined—Class I and Class II.

Class I:

A type of repeater set specified such that in a maximum length segment topology, only one such repeater set may exist between any two DTEs within a single collision domain.

Class II:

A type of repeater set specified such that in a maximum length segment topology, only two such repeater sets may exist between any two DTEs within a single collision domain.

More complex topologies are possible in systems that do not use worst-case cable. See clause 29 for requirements.

#### **27.1.2 Application perspective**

This subclause states the broad objectives and assumptions underlying the specification defined through clause 27.

##### **27.1.2.1 Objectives**

- a) Provide physical means for coupling two or more LAN segments at the Physical Layer.
- b) Support interoperability of independently developed physical, electrical, and optical interfaces.
- c) Provide a communication channel with a mean bit error rate, at the physical service interface equivalent to that for the attached PHY.
- d) Provide for ease of installation and service.
- e) Ensure that fairness of DTE access is not compromised.
- f) Provide for low-cost networks, as related to both equipment and cabling.
- g) Make use of building wiring appropriate for the supported PHYs and telephony wiring practices.

##### **27.1.2.2 Compatibility considerations**

All implementations of the repeater set shall be compatible at the MDI. The repeater set is defined to provide compatibility among devices designed by different manufacturers. Designers are free to implement circuitry within the repeater set in an application-dependent manner provided the appropriate PHY specifications are met.

### 27.1.2.2.1 Internal segment compatibility

Implementations of the repeater set that contain a MAC layer for network management or other purposes, irrespective of whether they are connected through an exposed repeater port or are internally ported, shall conform to the requirements of clause 30 on that port if repeater management is implemented.

### 27.1.3 Relationship to PHY

A close relationship exists between clause 27 and the PHY clauses, clause 23 for the 100BASE-T4 PHY and clauses 24 to 26 for the 100BASE-X PHYs. The PHY's PMA, PCS, and MDI specification provide the actual medium attachment, including drivers, receivers, and Medium Interface Connectors for the various supported media. The repeater clause does not define a new PHY; it utilizes the existing PHYs complete and without modification.

## 27.2 PMA interface messages

The messages between the repeater unit and the PMA in the PHY utilizes the PMA service interface defined in 23.3 and 24.3. The PMA service interface primitives are summarized below:

PMA\_TYPE.indicate  
PMA\_UNITDATA.request  
PMA\_UNITDATA.indicate  
PMA\_CARRIER.indicate  
PMA\_LINK.indicate  
PMA\_RXERROR.indicate

## 27.3 Repeater functional specifications

A repeater set provides the means whereby data from any segment can be received under worst case noise, timing, and amplitude conditions and then retransmitted with timing and amplitude restored to all other attached segments. Retransmission of data occurs simultaneously with reception. If a collision occurs, the repeater set propagates the collision event throughout the network by transmitting a Jam signal. If an error is received by the repeater set, no attempt is made to correct it and it is propagated throughout the network by transmitting an invalid signal.

The repeater set provides the following functional capability to handle data flow between ports:

- a) *Signal restoration.* Provides the ability to restore the timing and amplitude of the received signal prior to retransmission.
- b) *Transmit function.* Provides the ability to output signals on the appropriate port and encoded appropriately for that port. Details of signal processing are described in the specifications for the PHYs.
- c) *Receive function.* Provides the ability to receive input signals presented to the ports. Details of signal processing are described in the specifications for the PHYs.
- d) *Data-Handling function.* Provides the ability to transfer code-elements between ports in the absence of a collision.
- e) *Received Event-Handling requirement.* Provides the ability to derive a carrier signal from the input signals presented to the ports.
- f) *Collision-Handling function.* Provides the ability to detect the simultaneous reception of frames at two or more ports and then to propagate a Jam message to all connected ports.
- g) *Error-Handling function.* Provides the ability to prevent substandard links from generating streams of false carrier and interfering with other links.

- h) *Partition function*. Provides the ability to prevent a malfunctioning port from generating an excessive number of consecutive collisions and indefinitely disrupting data transmission on the network.
- i) *Receive Jabber function*. Provides the ability to interrupt the reception of abnormally long streams of input data.

### **27.3.1 Repeater functions**

The repeater set shall provide the Signal Restoration, Transmit, Receive, Data Handling, Received Event Handling, Collision Handling, Error Handling, Partition, and Receive Jabber functions. The repeater is transparent to all network acquisition activity and to all DTEs. The repeater will not alter the basic fairness criterion for all DTEs to access the network or weigh it toward any DTE or group of DTEs regardless of network location.

The Transmit and Receive functional requirements are specified by the PHY clauses, clause 23 for 100BASE-T4 and clauses 24 to 26 for 100BASE-X.

#### **27.3.1.1 Signal restoration functional requirements**

##### **27.3.1.1.1 Signal amplification**

The repeater set (including its integral PHYs) shall ensure that the amplitude characteristics of the signals at the MDI outputs of the repeater set are within the tolerances of the specification for the appropriate PHY type. Therefore, any loss of signal-to-noise ratio due to cable loss and noise pickup is regained at the output of the repeater set as long as the incoming data is within system specification.

##### **27.3.1.1.2 Signal wave-shape restoration**

The repeater set (including its integral PHYs) shall ensure that the wave-shape characteristics of the signals at the MDI outputs of a repeater set are within the specified tolerance for the appropriate PHY type. Therefore, any loss of wave-shape due to PHYs and media distortion is restored at the output of the repeater set.

##### **27.3.1.1.3 Signal retiming**

The repeater set (including its integral PHYs) shall ensure that the timing of the encoded data output at the MDI outputs of a repeater set are within the specified tolerance for the appropriate PHY type. Therefore, any receive jitter from the media is removed at the output of the repeater set.

#### **27.3.1.2 Data-handling functional requirements**

##### **27.3.1.2.1 Data frame forwarding**

The repeater set shall ensure that the data frame received on a single input port is distributed to all other output ports in a manner appropriate for the PHY type of that port. The data frame is that portion of the packet after the SFD and before the end-of-frame delimiter. The only exceptions to this rule are when contention exists among any of the ports, when the receive port is partitioned as defined in 27.3.1.6, when the receive port is in the Jabber state as defined in 27.3.1.7, or when the receive port is in the Link Unstable state as defined in 27.3.1.5.1. Between unpartitioned ports, the rules for collision handling (see 27.3.1.4) take precedence.

##### **27.3.1.2.2 Received code violations**

The repeater set shall ensure that any code violations received while forwarding a packet are propagated to all outgoing segments. These code violations shall be forwarded as received or replaced by `bad_code` (see 23.2.1.2) or `/H/` (see 24.2.2.1) code-groups, as appropriate for the outgoing PHY type. Once a received code

violation has been replaced by `bad_code` or the `/H/` code-group, this substitution shall continue for the remainder of the packet regardless of its content. The only exception to this rule is when contention exists among any of the ports, where the rules for collision handling (see 27.3.1.4) then take precedence.

### 27.3.1.3 Received event-handling functional requirements

#### 27.3.1.3.1 Received event handling

For all its ports, the repeater set shall implement a function (`scarrier_present`) that represents a received event. Received events include both the data frame and any encapsulation of the data frame such as Preamble, SFD and the code-groups `/H/`, `/J/`, `/K/`, `bad_code`, `eop`, `/T/`, `/R/`, etc. A received event is exclusive of the IDLE pattern. Upon detection of `scarrier_present` from one port, the repeater set repeats all received signals in the data frame from that port to the other port (or ports) as described in figure 27-2.

#### 27.3.1.3.2 Preamble regeneration

The repeater set shall output preamble as appropriate for the outgoing PHY type followed by the SFD.

#### 27.3.1.3.3 Start-of-packet propagation delay

The start-of-packet propagation delay for a repeater set is the time delay between the start of the packet (see 24.6 and 23.11.3) on its repeated-from (input) port to the start of the packet on its repeated-to (output) port (or ports). This parameter is referred to as the SOP delay. The maximum value of this delay is constrained by table 27-2.

#### 27.3.1.3.4 Start-of-packet variability

The start-of-packet variability for a repeater set is defined as the total worst-case difference between start-of-packet propagation delays for successive packets separated by 104 bit times (BT) or less at the same input port. The variability shall be less than or equal to those specified in table 27-1.

**Table 27-1—Start-of-packet variability**

Input port type	Variability (BT)
100BASE-FX	7.0
100BASE-TX	7.0
100BASE-T4	8.0

### 27.3.1.4 Collision-handling functional requirements

#### 27.3.1.4.1 Collision detection

The repeater performs collision detection by monitoring all its enabled input ports for received events. When the repeater detects received events on more than one input port, it shall enter a collision state and transmit the Jam message to all of its output ports.

#### 27.3.1.4.2 Jam generation

While a collision is occurring between any of its ports, the repeater unit shall transmit the Jam message to all of the PMAs to which it is connected. The Jam message shall be transmitted in accordance with the repeater state diagram in figure 27-4 and figure 27-5.

#### 27.3.1.4.3 Collision-jam propagation delay

The start-of-collision Jam propagation delay for a repeater set is the time delay between the start of the second packet input signals to arrive at its port and the start of Jam (see 24.6 and 23.11) out on all ports. This parameter is referred to as the SOJ delay. The delay shall be constrained by table 27-2.

**Table 27-2—Start-of-packet propagation and start-of-collision Jam propagation delays**

Class I repeater	Class II repeater with all ports TX/FX	Class II repeater with any port T4
$SOP + SOJ \leq 140 \text{ BT}$	$SOP \leq 46 \text{ BT}, SOJ \leq 46 \text{ BT}$	$SOP+SOJ \leq 67 \text{ BT}$

#### 27.3.1.4.4 Cessation-of-collision Jam propagation delay

The cessation-of-collision Jam propagation delay for a repeater set is the time delay between the end of the packet (see 24.6 and 23.11.3) that creates a state such that Jam should end at a port and the end of Jam (see 24.6 and 23.11.3) at that port. The states of the input signals that should cause Jam to end are covered in detail in the repeater state diagrams. This parameter is referred to as the EOJ delay. The delay shall be constrained by table 27-3.

**Table 27-3—Cessation-of-collision Jam propagation delay**

Class I repeater	Class II repeater
$EOJ \leq SOP$	$EOJ \leq SOP$

#### 27.3.1.5 Error-handling functional requirements

##### 27.3.1.5.1 100BASE-X carrier integrity functional requirements

In 100BASE-TX and 100BASE-FX systems, it is desirable that the repeater set protect the network from some transient fault conditions that would disrupt network communications. Potential likely causes of such conditions are DTE and repeater power-up and power-down transients, cable disconnects, and faulty wiring.

Each 100BASE-TX and 100BASE-FX repeater PMA interface shall contain a self-interrupt capability, as described in figure 27-9, to prevent a segment's spurious carrier activity from reaching the repeater unit and hence propagating through the network.

The repeater PMA interface shall count consecutive false carrier events. A false carrier event is defined as a carrier event that does not begin with a valid start-of-stream delimiter (see 24.2.2.1.4). The count shall be incremented on each false carrier event and shall be reset on reception of a valid carrier event. In addition, each PMA interface shall contain a false carrier timer, which is enabled at the beginning of a false carrier event and reset at the conclusion of such an event. A repeater unit shall transmit the Jam message to all of the PMAs to which it is connected for the duration of the false carrier event or until the duration of the event

exceeds the time specified by the `false_carrier_timer` (see 27.3.2.1.4), whichever is shorter. The Jam message shall be transmitted in accordance with the repeater state diagram in figure 27-4 and figure 27-5. The LINK UNSTABLE condition shall be detected when the False Carrier Count exceeds the value `FCCLimit` (see 27.3.2.1.1) or the duration of a false carrier event exceeds the time specified by the `false_carrier_timer`. In addition, the LINK UNSTABLE condition shall be detected upon power-up reset.

Upon detection of LINK UNSTABLE, the port shall perform the following:

- a) Inhibit sending further messages to the repeater unit.
- b) Inhibit sending further output messages from the repeater unit.
- c) Continue to monitor activity on that PMA interface.

The repeater shall exit the LINK UNSTABLE condition when one of the following is met:

- a) The repeater has detected no activity (Idle) for more than the time specified by `ipg_timer` plus `idle_timer` (see 27.3.2.1.4) on port X.
- b) A valid carrier event with a duration greater than the time specified by `valid_carrier_timer` (see 27.3.2.1.4) has been received, preceded by no activity (Idle) for more than the time specified by `ipg_timer` (see 27.3.2.1.4) on port X.

#### 27.3.1.5.2 Speed handling

If the PHY has the capability of detecting speeds other than 100 Mb/s, then the repeater set shall have the capability of blocking the flow of non-100 Mb/s signals. The incorporation of 100 Mb/s and 10 Mb/s repeater functionality within a single repeater set is beyond the scope of this standard.

#### 27.3.1.6 Partition functional requirements

In large multisegment networks it may be desirable that the repeater set protect the network from some fault conditions that would disrupt network communications. A potentially likely cause of this condition could be due to a cable fault.

Each repeater PMA interface shall contain a self-interrupt capability, as described in figure 27-8, to prevent a faulty segment's carrier activity from reaching the repeater unit and hence propagating through the network. The repeater PMA interface shall count consecutive collisions. The count shall be incremented on each transmission that suffers a collision and shall be reset on a successful transmission. If this count exceeds the value `CCLimit` (see 27.3.2.1.1) the Partition condition shall be detected.

Upon detection of Partition, the port shall perform the following:

- a) Inhibit sending further input messages to the repeater unit.
- b) Continue to output messages from the repeater unit.
- c) Continue to monitor activity on that PMA interface.

The repeater shall reset the Partition function when one of the following conditions is met:

- a) On power-up reset.
- b) The repeater has detected activity on the port for more than the number of bits specified for `no_collision_timer` (see 27.3.2.1.4) without incurring a collision.

#### 27.3.1.7 Receive jabber functional requirements

Each repeater PMA interface shall contain a self-interrupt capability, as described in figure 27-7, to prevent an illegally long reception of data from reaching the repeater unit. The repeater PMA interface shall provide

a window of duration jabber\_timer bit times (see 27.3.2.1.4) during which the input messages may be passed on to other repeater unit functions. If a reception exceeds this duration, the jabber condition shall be detected.

Upon detection of jabber, the port shall perform the following:

- a) Inhibit sending further input messages to the repeater unit.
- b) Inhibit sending further output messages from the repeater unit.

The repeater PMA interface shall reset the Jabber function and re-enable data transmission and reception when either one of the following conditions is met:

- a) On power-up reset.
- b) When carrier is no longer detected.

### **27.3.2 Detailed repeater functions and state diagrams**

A precise algorithmic definition is given in this subclause, providing a complete procedural model for the operation of a repeater, in the form of state diagrams. Note that whenever there is any apparent ambiguity concerning the definition of repeater operation, the state diagrams should be consulted for the definitive statement.

The model presented in this subclause is intended as a primary specification of the functions to be provided by any repeater unit. It is important to distinguish, however, between the model and a real implementation. The model is optimized for simplicity and clarity of presentation, while any realistic implementation should place heavier emphasis on such constraints as efficiency and suitability to a particular implementation technology.

It is the functional behavior of any repeater unit implementation that shall match the standard, not the internal structure. The internal details of the procedural model are useful only to the extent that they help specify the external behavior clearly and precisely. For example, the model uses a separate Receive Port Jabber state diagram for each port. However, in actual implementation, the hardware may be shared.

The notation used in the state diagram follows the conventions of 1.2.1. Note that transitions shown without source states are evaluated at the completion of every state and take precedence over other transition conditions.

#### **27.3.2.1 State diagram variables**

##### **27.3.2.1.1 Constants**

###### **CCLimit**

The number of consecutive collisions that must occur before a segment is partitioned.

Values: Positive integer greater than 60.

###### **FCCLimit**

The number of consecutive False Carrier events that must occur before a segment is isolated.

Value: 2.



**27.3.2.1.2 Variables****activity**(Port designation)

Indicates port activity status. The repeater core effects a summation of this variable received from all its attached ports and responds accordingly.

Values: 0; no frame or packet activity at any port.  
1; exactly 1 port of the repeater set has frame or packet activity input.  
>1; more than 1 port of the repeater set has frame or packet activity input. Alternately, one or more ports has detected a carrier that is not valid.

**all\_data\_sent**

Indicates if all received data frame bits or code-groups from the current frame have been sent. During or after collision the all\_data\_sent variable follows the inverse of the carrier of port N.

Values: true; all received data frame bits or code-groups have been sent.  
false; all received data frame bits or code-groups have not been sent.

**begin**

The Interprocess flag controlling state diagram initialization values.

Values: true  
false

**carrier\_status**(X)

Signal received from PMA; indicates the status of sourced Carrier input at port X.

Values: ON; the carrier\_status parameter of the PMA\_CARRIER.indicate primitive for port X is ON.  
OFF; the carrier\_status parameter of the PMA\_CARRIER.indicate primitive for port X is OFF.

**data\_ready**

Indicates if the repeater has detected and/or decoded the MAC SFD and is ready to send the received data.

Values: true; the MAC SFD has been detected and/or decoded.  
false; the MAC SFD has not been detected nor decoded.

**force\_jam**(X)

Flag from Carrier Integrity state diagram for port X, which determines whether all ports should transmit Jam.

Values: true; the Carrier Integrity Monitor has determined that it requires all ports be forced to transmit Jam.  
false; the Carrier Integrity Monitor has determined that it does not require all ports be forced to transmit Jam.

Default: for T4 ports: false

**isolate**(X)

Flag from Carrier Integrity state diagram for port X, which determines whether a port should be enabled or disabled.

Values: true; the Carrier Integrity Monitor has determined the port should be disabled.  
false; the Carrier Integrity Monitor has determined the port should be enabled.

**jabber**(X)

Flag from Receive Timer state diagram for port X which indicates that the port has received excessive length activity.

Values: true; port has exceeded the continuous activity limit.  
false; port has not exceeded the continuous activity limit.

**link\_status**(X)

Signal received from PMA; indicates link status for port X (see 23.1.4.5 and 24.3.1.5).

Values: OK; the link\_status parameter of the PMA\_LINK.indicate primitive for port X is OK.  
READY; the link\_status parameter of the PMA\_LINK.indicate primitive for port X is  
READY.  
FAIL; the link\_status parameter of the PMA\_LINK.indicate primitive for port X is  
FAIL.

opt(X)

Implementation option. Either value may be chosen for repeater implementation.

Values: true; port will emit the JamT4 pattern in response to collision conditions.  
false; port will append Jam pattern after preamble and SFD in response to collision  
conditions.

OUT(X)

Type of output repeater is sourcing at port X.

Values: Idle; repeater is transmitting an IDLE pattern as described by 23.4.1.2 or 24.2.2.1.2.  
In(N); repeater is transmitting rx\_code\_bit(s) as received from port (N) except /J/K/ (see  
24.3.4.2).  
Pream; repeater is sourcing preamble pattern as defined by the PMA or PCS of the port  
type (see 23.2.1.2, 24.2.2.2, figure 23-6, and figure 24-5).  
Data; repeater is transmitting data frame on port X. This data represents the original  
MAC source data field, properly encoded for the PHY type (see 23.2.1.2 and 24.2.2.2).  
Jam; repeater is sourcing well formed arbitrary data encodings, excluding SFD, to the  
port PMA.  
JamX; repeater is sourcing the pattern 010101... repetitively on port X.  
JamT4; repeater is sourcing the pattern +-+... repetitively on port X  
SFD; repeater is sourcing the Start Frame Delimiter on port X encoded as defined by the  
appropriate PHY (see 23.2.3 and figure 24-5).  
/J/K/; repeater is sourcing the code-groups /J/K/ as defined by the PMA on port X (see  
24.2.2.1.4).  
/T/R/; repeater is sourcing the code-groups /T/R/ as defined by the PMA on port X (see  
24.2.2.1.5).  
DF; repeater is sourcing the data frame of the packet on port X. These are code elements  
originating on port N exclusive of EOP1-5, SOSA, and SOSB (see 23.2.3 and 23.2.4).  
EOP; repeater is sourcing end-of-packet delimiter (EOP1-5) as defined by the  
appropriate PMA on port X (see 23.2.1.2 and 23.2.4.1).  
bad\_code; repeater is sourcing bad\_code as defined by the PMA of the transmit port (see  
23.2.4.1).  
tx\_err; repeater is sourcing a transmit error code element, either bad\_code (see 23.2.4.1)  
or the code-group /H/ (see 24.2.2.1) as appropriate to the outgoing PHY type.

partition(X)

Flag from Partition state diagram for port X, which determines whether a port receive path should  
be enabled or disabled.

Values: true; port has exceeded the consecutive collision limit.  
false; port has not exceeded the consecutive collision limit.

**rxerror\_status(X)**

Signal received from PMA; indicates if port X has detected an error condition from the PMA (see 23.3.7.1 and figure 24-14). The repeater need not propagate this error condition during collision events.

Values: ERROR; the rxerror\_status parameter of the PMA\_RXERROR.indicate primitive for port X is ERROR.  
NO\_ERROR; the rxerror\_status parameter of the PMA\_RXERROR.indicate primitive for port X is NO\_ERROR.

**RX\_ER(X)**

Signal received from PCS; indicates if port X has detected an error condition from the PCS (see 23.2.1.4, 24.2.3.2, figure 23-10, and figure 24-11). The repeater need not propagate this error condition during collision events.

Values: true; the PCS RX\_ER signal for port X is asserted.  
false; the PCS RX\_ER signal for port X is negated.

**scarrier\_present(X)**

Signal received from PMA; indicates the status of sourced Carrier input at port X.

Values: true; the carrier\_status parameter of the PMA\_CARRIER.indicate primitive for port X is ON.  
false; the carrier\_status parameter of the PMA\_CARRIER.indicate primitive for port X is OFF.

**source\_type(X)**

Signal received from PMA; indicates PMA type for port X. The first port to assert activity maintains the source type status for all transmitting port(s) until activity is deasserted. Repeaters may optionally force nonequality on comparisons using this variable. It must then follow the behavior of the state diagrams accordingly and meet all the delay parameters as applicable for the real implemented port type(s).

Values: FXTX; the pma\_type parameter of the PMA\_TYPE.indicate primitive for port X is X.  
T4; the pma\_type parameter of the PMA\_TYPE.indicate primitive for port X is T4.

**27.3.2.1.3 Functions****command(X)**

A function that passes an inter-process flag to all ports specified by X.

Values: copy; indicates that the repeater core has summed the activity levels of its active ports and is in the ACTIVE state.  
collision; indicates that the repeater core has summed the activity levels of its active ports and is in the JAM state.  
quiet; indicates that the repeater core has summed the activity levels of its active ports and is in the IDLE state.

**port(Test)**

A function that returns the designation of a port passing the test condition. For example, port(activity = scarrier\_present) returns the designation: X for a port for which scarrier\_present = true. If multiple ports meet the test condition, the Port function will be assigned one and only one of the acceptable values.

**27.3.2.1.4 Timers**

All timers operate in the same fashion. A timer is reset and starts timing upon entering a state where “start\_x\_timer” is asserted. At time “x” after the timer has been started, “x\_timer\_done” is asserted and remains asserted until the timer is reset. At all other times, “x\_timer\_not\_done” is asserted.

When entering a state where “start x\_timer” is asserted, the timer is reset and restarted even if the entered state is the same as the exited state.

The timers used in the repeater state diagrams are defined as follows:

**false\_carrier\_timer**

Timer for length of false carrier (27.3.1.5.1) that must be present before the ISOLATION state is entered. The timer is done when it reaches 450 – 500 BT.

**idle\_timer**

Timer for length of time without carrier activity that must be present before the ISOLATION state is exited (27.3.1.5.1). The timer is done when it reaches  $33\ 000 \pm 25\%$  BT.

**ipg\_timer**

Timer for length of time without carrier activity that must be present before carrier integrity tests (27.3.1.5.1) are re-enabled. The timer is done when it reaches 64 – 86 BT.

**jabber\_timer**

Timer for length of carrier which must be present before the Jabber state is entered (27.3.1.7). The timer is done when it reaches 40 000 – 75 000 BT.

**no\_collision\_timer**

Timer for length of packet without collision before the Partition state is exited (27.3.1.6). The timer is done when it reaches 450 – 560 BT.

**valid\_carrier\_timer**

Timer for length of valid carrier that must be present before the Isolation state is exited (27.3.1.5.1). The timer is done when it reaches 450 – 500 BT.

### 27.3.2.1.5 Counters

**CC(X)**

Consecutive port collision count for port X. Partitioning occurs on a terminal count of CCLimit being reached.

Values: Non-negative integers up to a terminal count of CCLimit.

**FCC(X)**

False Carrier Counter for port X. Isolation occurs on a terminal count of FCCLimit being reached.

Values: Non-negative integers up to a terminal count of FCCLimit.

### 27.3.2.1.6 Port designation

Ports are referred to by number. Port information is obtained by replacing the X in the desired function with the number of the port of interest. Ports are referred to in general as follows:

**X**

Generic port designator. When X is used in a state diagram, its value is local to that diagram and not global to the set of state diagrams.

**N**

Is defined by the Port function on exiting the IDLE or JAM states of figure 27-2. It indicates a port that caused the exit from these states.

**ALL**

Indicates all repeater ports are to be considered. All ports shall meet test conditions in order for the test to pass.

## ALLXN

Indicates all ports except N should be considered. All ports considered shall meet the test conditions in order for the test to pass.

## ANY

Indicates all ports are to be considered. One or more ports shall meet the test conditions in order for the test to pass.

27.3.2.2 State diagrams

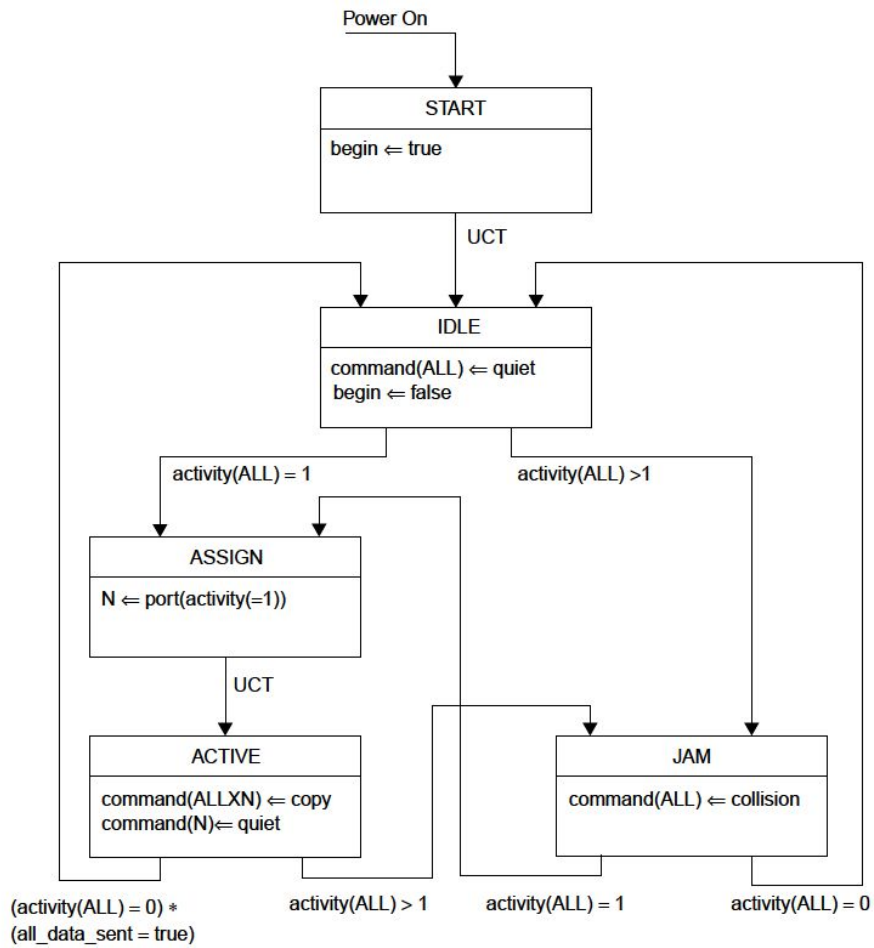

Figure 27-2—Repeater core state diagram