

**UNITED STATES DISTRICT COURT  
FOR THE EASTERN DISTRICT OF TEXAS  
TYLER DIVISION**

<p><b>CHRIMAR SYSTEMS, INC., <i>et al.</i>,</b></p> <p style="text-align: center;"><b>Plaintiffs,</b></p> <p><b>v.</b></p> <p><b>ALCATEL-LUCENT, INC., <i>et al.</i>,</b></p> <p style="text-align: center;"><b>Defendants.</b></p>	<p><b>Case No. 6:15-CV-163-JDL</b></p> <p><b>LEAD CASE</b></p>
<p><b>CHRIMAR SYSTEMS, INC., <i>et al.</i>,</b></p> <p style="text-align: center;"><b>Plaintiffs,</b></p> <p><b>v.</b></p> <p><b>AMX</b></p> <p style="text-align: center;"><b>Defendant.</b></p>	<p><b>Case No. 6:15-CV-164-JDL</b></p>

**DECLARATION OF RICH SEIFERT**

## INTRODUCTION

1. I am an expert in the field of communications systems, and have been retained by McDermott, Will & Emery, representing Defendant AMX and by Williams Morgan, P.C., representing Defendants Alcatel-Lucent USA, Inc., Alcatel-Lucent Holdings, Inc., and ALE USA Inc., to analyze, render opinions, and/or provide expert testimony regarding the meaning of certain terms in U.S. Patent Nos. 8,155,012 ( "the '012 patent), 8,942,107 ("the '107 patent), 8,902,760 ("the '760 patent"), and 9,019,838 ("the '838 patent") (collectively, the Patents-in-Suit) as asserted by Chrimar Systems, Inc., *et al.* (collectively, hereinafter "Chrimar" or "Plaintiff").

2. I am being compensated at my usual rate of \$400 per hour for the time spent by me in connection with this case. This compensation is not contingent upon my opinions or the outcome of the case. I have personal knowledge of the facts set forth in this declaration and, if called to testify as a witness, could and would competently testify to them under oath.

3. This declaration is responsive to the December 17, 2015 declaration of Les Baxter on behalf of Plaintiffs in which he provides his conclusions as to the meaning of certain terms.

4. This declaration also provides my opinions as to the indefiniteness of certain claims.

5. I incorporate by reference my expert report regarding the invalidity of certain asserted claims of the '012 patent dated Mar 10, 2015, submitted in prior case nos. 13-cv-880-JDL and 13-cv-881-JDL, which includes, *inter alia*, my background and qualifications, previous documents reviewed, statements of legal principles, claim construction, and my opinion regarding a person of ordinary skill in the art. For convenience, some of this material is reproduced below.



## BACKGROUND/QUALIFICATIONS

6. I am currently the President of Networks & Communications Consulting in Los Gatos, California. I received a Bachelor of Engineering (Electrical Engineering) degree from the City College of New York in 1976. I received a Master of Science (Electrical Engineering) degree in 1979 from the Worcester Polytechnic Institute, a Master of Business Administration degree in 1984 from Clark University, and a Juris Doctor degree in 2006 from Santa Clara University. I have over 45 years of experience in computer and communications technology, and have worked for the past 35 years on the architecture and design of data communications networks and networking products. My curriculum vitae is attached hereto as Exhibit A, which includes lists of publications I have authored and legal cases in which I have been involved.

## DOCUMENTS AND MATERIALS CONSIDERED

7. A list of additional materials (beyond those listed in my earlier report) that I have considered in rendering the opinions expressed herein is attached as Exhibit B. In forming my opinions, I have also relied on my experience and education.

## LEGAL PRINCIPLES

8. I am not a patent attorney and offer no opinions on the law. However, I have been informed by counsel of the legal standards that apply, and I have applied them in arriving at my conclusions.

9. I understand that a patent is invalid for indefiniteness if its claims, read in light of the intrinsic record, fail to inform, with reasonable certainty, those skilled in the art about the scope of the invention.

10. I understand that patent claims have their plain and ordinary meaning to one of skill in the art when read in the context of the intrinsic record unless the patentee has acted as his own lexicographer or disclaimed some scope of the claim.

**PRIOR CLAIM CONSTRUCTION**

11. My understanding is that some of the terms in the claims of the '012 patent were construed by the Court in case nos. 13-cv-880-JDL and 13-cv-881-JDL, as shown below. *See, generally*, Memorandum Opinion and Order, dated Oct. 22, 2014 (the "10/22/14 Order"), Memorandum Opinion and Order dated Jan. 8, 2015 (the "1/8/15 Order"), and Memorandum Opinion and Order dated Jan. 16, 2015 (the "1/16/15 Order").

Claim Term	Construction
"distinguishing information about the piece of Ethernet terminal equipment" (Claim 31)	"information to distinguish the piece of Ethernet data terminal equipment from at least one other piece of Ethernet data terminal equipment" 10/22/14 Order at 15; 1/16/15 Order at 3.
"to distinguish the piece of terminal equipment" (Claim 67)	"to distinguish the piece of data terminal equipment having an Ethernet connector from at least one other piece of terminal equipment having an Ethernet connector" 10/22/14 Order at 15; 1/16/15 Order at 3.
"impedance" (Claims 31, 35, 67, 77)	"opposition to the flow of current" 1/16/15 Order at 3.
"terminal equipment" (Claims 67, 106)	"device at which data transmission can originate or terminate" 1/16/15 Order at 4.
"Ethernet data terminal equipment" (Claims 31, 35, 43, 55)	"device at which data transmission can originate or terminate and that is capable of Ethernet communication" 1/16/15 Order at 4.
"[A]n adapted piece of Ethernet data	These preambles <i>are</i> limiting and have their

terminal equipment” (Claim 31) and  “[A] method for adapting a piece of terminal equipment” (Claim 67)	plain and ordinary meaning. 1/16/15 Order at 4 (emphasis in original).
“arranging impedance within the at least one path” (Claim 67)	Plain meaning. 1/16/15 Order at 14.
“wherein distinguishing information about the piece of Ethernet data terminal equipment is associated to impedance within the at least one path” (Claim 31)	Plain meaning. 1/16/15 Order at 16.

**PERSON OF ORDINARY SKILL IN THE ART**

12. I have been informed and understand that the following criteria are useful in determining the level of ordinary skill in the art with respect to a given patent: (a) the educational level of the inventor; (b) the type of problems encountered in the art; (c) prior art solutions to those problems; (d) rapidity with which innovations are made; (e) sophistication of the technology in the art; and (f) the educational level of active workers in the field. A person of ordinary skill in the art with respect to the asserted patent would have had at least a B.S. degree in electrical engineering or computer science, or the equivalent, and at least three years of experience in the design of network communications products.

13. Specifically, such a person would be familiar with, *inter alia*, data communications protocols, data communications standards (and standards under development at the time), and the behavior and use of common data communications products available on the market.

14. At the time of the filing of the Patents-in-Suit, through the time of the earliest claimed priority date of April 10, 1998, I was at least a person of ordinary skill in the art, and regularly worked with and supervised others at that level of skill.

### ADMITTED PRIOR ART

#### **(A) Ethernet Connectors**

15. The Patents-in-Suit disclose and incorporate by reference U.S. Patent 5,406,260 (also assigned to Plaintiff Chromar Systems, Inc., in the instant case) as relevant prior art. They state that the '260 patent had already disclosed:

One method ... is disclosed in U.S. Pat. No. 5,406,260 issued to Cummings, et al., (hereby incorporated by reference) which discusses a means for detecting the unauthorized removal of a networked device by injecting a low current power signal into each existing communications link. A sensor monitors the returning current flow and can thereby detect a removal of the equipment. This method provides a means to monitor the connection status of any networked electronic device thus providing an effect theft detection/deterrent system."

*See, e.g., '012 Patent, 2:12-19.*

16. Coupling a path across specific contacts of an Ethernet connector comprising 8 contacts (numbered 1 through 8) was also known to persons of ordinary skill. The IEEE 802.3i-1990 specification (10BASE-T) discloses such an Ethernet connector, with eight contacts numbered 1 through 8:

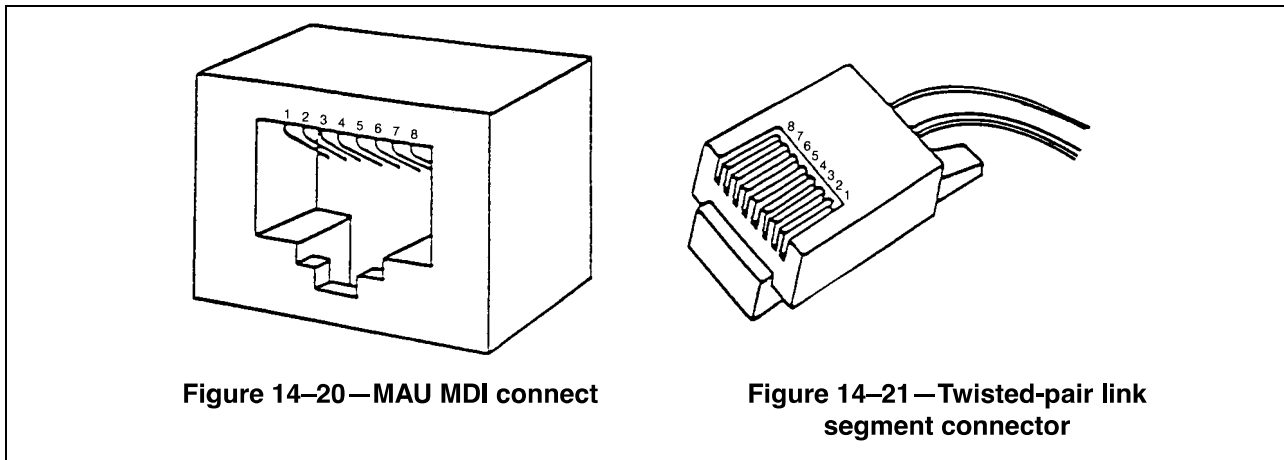

**IEEE 802.3i-1990 Figures 14-20 and 14-21: MAU MDI Connect and Twisted-pair Link Segment Connector**

IEEE 802.3i-1990 at 52 (§14.5.2); *see also* IEEE 802.3-1993 at 268.

17. Mr. Baxter has conceded that having a path coupled across selected contacts of a given Ethernet connector was already known to persons of ordinary skill and was not part of any inventive element of claim 31 of the '012 patent.

Q: And you say a person would understand what it means to have a path coupled between contacts of an Ethernet connector, correct?

A: Mm-hmm.

...

Q: But you're not asserting that the inventors invented having a path across the two contacts, right?

A: No.

...

Q: ...Would a person of ordinary skill in the art at the date of filing of the earliest patent application or the date of invention have already seen something similar to the schematic in paragraph 77?

A: Whether they would have seen this exact schematic or not, I don't know, but certainly you would be familiar with what the Ethernet connector is, what an impedance is, and what a path is. So I think those are very familiar concepts to anyone of skill in the art at that time and since Ethernet, you know, twisted pairing had been around for some years, certainly they would have seen schematics that had connections across the contacts of a modular jack.

Baxter October 22, 2014 Deposition at 114-116 (objections omitted).

**(B) Ohm's Law**

18. Voltage (V), current (I), and impedance (Z) are interrelated as expressed by Ohm's law. *See, generally, Crow at 109-126.* When analyzing circuits carrying DC current, impedance may be simplified to resistance (R).<sup>3</sup>

19. Ohm's Law states that Voltage (V) = Current (I) x Resistance (R), i.e.,  $V = I \times R$ . Crow at 112.

20. Applying Ohm's law, one could maintain a constant voltage, and change the current by changing the resistance. Any increase in current would be due to a decrease in the resistance, and vice-versa. Similarly, for a constant resistance, Ohm's law says that you can change the current by changing the applied voltage.

21. Any conductive path *inherently* has the capability to draw different magnitudes of current because it is governed by the principles of Ohm's law. One can always apply voltages of different magnitudes to yield currents of different magnitudes. Or, one can simply change the impedance (resistance) within the path to produce a different magnitude of current.

22. Direct current (DC) is a current that does not change in polarity. While the magnitude of the current may vary, the net flow of electric charge does not change direction in a DC circuit.

23. Alternating current (AC) is a current that does change in polarity. Over time, the net flow of electric charge changes directions, either periodically or aperiodically.

24. In the real-world environment for Ethernet data terminal equipment (e.g., the end devices claimed in the Patents-in-Suit), any DC current drawn by the device will always correlate to a draw of power by the device, related to that current. In other

---

<sup>3</sup> In the general case of combined AC/DC circuits, voltage, current, and impedance are all vector quantities requiring the use of complex numbers in the mathematical analysis. Since the claims of the Patents-in-Suit relate to DC currents, we can simplify the analysis and consider voltage, current, and resistance to be scalars with a given value.

words, current flow across Ethernet cable wiring, through the recited contacts of an Ethernet connector, and through a conductive path within circuitry in a device will always consume power. This is because each of these elements will have some appreciable resistance.

25. In a DC circuit, power ( $P$ ) is defined as the voltage ( $V$ ) applied, multiplied by the resulting current ( $I$ ), i.e.  $P = V \times I$ . Crow at 184. Combining Ohm's law with the power equation,  $P = V \times I = (I \times R) \times I = I^2 \times R$ . Because  $R$  will always have a non-zero value, a device that is drawing current will always consume power as well.

### **(C) Ethernet Networks and Naming Conventions**

26. 10BASE-T networks use twisted-pair wiring to send signals. *See, e.g.,* Seifert Report at ¶ 151. The same connector discussed above (RJ-45) is used to connect the communications cable to the network circuitry inside the end device. On each pair used, an isolation transformer blocks continuous DC current from passing across the transformer, but AC currents (representing digital data) or DC pulses can pass across the magnetic coupling between the two coils in the isolation transformer.

27. The term "Base-T" standing alone is not used in the IEEE specification. The only use of the term is in the context of an entire designation, e.g., 10BASE-T (or 100BASE-TX, 1000BASE-T, etc.)

28. The IEEE Standards introduced shorthand names for the the various Ethernet physical media systems. A complete list of these shorthand names (as of 1998) can be found in Rich Seifert, *Gigabit Ethernet: Technology and Applications for High-Speed LANs* (Addison-Wesley 1998) at 15. There is no standard that is simply designated BASE-T (or "BaseT", as used in the Patents-in-Suit). Neither are all twisted-pair configurations designated as XBASE-T. For example, 1BASE5 is an Ethernet standard employing a single unshielded twisted pair, operating at 1 Mb/s, with a 500 meter

maximum length. Similarly, the AUI in 10BASE5 employs four twisted pairs, but has no designation of XBASE-T.

29. The naming convention for the variety of Ethernet media systems is explained below:

In order to avoid having to say things like, “10 Mb/s Ethernet using two pairs of Category 3 unshielded twisted pair” or “Gigabit Ethernet on two optical fibers using longwave laser optics,” the IEEE 802.3 standards committee developed a shorthand notation that allows us to refer to any particular standard implementation of Ethernet. Hence, a given flavor of Ethernet is referred to as

n-signal-phy

where

*n* is the data rate in megabits per second (that is, 1, 10, 100, or 1000).

*signal* indicates either BASE, if the signaling used on the channel is baseband (that is, the physical medium is dedicated to the Ethernet, with no other communications system sharing the medium) or BROAD, if the signaling is broadband (that is, the physical medium can simultaneously support Ethernet and other, possibly non-Ethernet services).<sup>11</sup>

*phy* indicates the nature of the physical medium. In the first few systems to which this notation was applied, *phy* indicated the maximum length of a cable segment, in meters (rounded to the nearest 100 m). In later systems, this convention was dropped and *phy* became simply a code for the particular media type.<sup>12</sup>

12. As part of this change in conventions, codes using the “old style” (length) convention do not use a hyphen between the signaling type and the physical medium designation (for example, 10BASE5 and 10BASE2). Later designations always have a hyphen (for example, 10BASE-T and 100BASE-FX) to show the change in meaning. In addition, the signaling designation is always capitalized. Now you can impress your coworkers and correct your boss when he or she writes “10BaseT” instead of the strictly correct “10BASE-T.” Please don’t call me if doing this causes your career to veer in an undesirable direction.

*Id.* at 14

30. Thus, a person of ordinary skill in the art would not consider the term “Base-T” standing alone to define a type of Ethernet network. The definition is incomplete, nor is the naming or spelling correct. As discussed above, even if the *intent* is to provide a shorthand notation for Ethernet operation over twisted pair, the term is not inclusive of systems such as 1BASE5 or the AUI of 10BASE5. “Base-T” is simply not



a term of art as of any of the claimed priority dates. A person of ordinary skill would not know the complete set (if any) of Ethernet media systems to which it refers.

31. The specification only discusses 10BASE-T, and makes no mention of other systems that were known at the time, including 100BASE-TX, 100BASE-T4, and the emerging 1000BASE-T. Those other system operate at higher data rates, using lower signaling voltages and multi-level signaling, which results in significantly lower margins for error due to noise or inteference. *See, generally, IEEE 802.3.* This is further demonstrated by the fact that 10BASE-T allows for the use of (lower quality) Category 3 wiring where 100BASE-TX and 1000BASE-T require at least Category 5 wiring. *Id.*

32. Since the system of the Patents-in-Suit (and the prior art '260 patent, incorporated by reference) all depend on superimposing a low DC current onto the operational Ethernet cabling, without causing appreciable interference to the Ethernet signals, it is possible (if not likely) that the disclosed embodiments would not function correctly in the more constrained environment of those higher-speed systems. Thus, there is no reason for a person of ordinary skill to assume that the inventors meant their invention to include operation over any system other than 10BASE-T, the only one disclosed in the patents.

33. 100BASE-TX was formally adopted by the IEEE in 1995. 1000BASE-T was available in draft form at least as early as 1998 but was not formally adopted by the IEEE until 1999. A person of ordinary skill in the art would have known and had access to these standards and recognized the differences between the systems described in them vis-à-vis 10BASE-T. Limiting the recitation in the provisional and utility applications solely to 10BASE-T provides the only meaning for the term "BaseT," which appears to be a creation of the applicants or their attorney.

## PROSECUTION HISTORY

34. The '012 patent was filed as application no. 12/239,001 on September 26, 2008. '012 Patent at 1. The '012 patent states that it is a continuation of an earlier application no. 10/668,708 filed on September 23, 2003, which is a continuation of application no. 09/370,430 filed on August 9, 1999, which is a continuation-in-part of a PCT filing PCT/US99/07846 filed on April 8, 1999, which claims the benefit of provisional application no. 60/081,279, filed on April 10, 1998. '012 Patent at 1.

35. The '107 patent was filed as application no. 13/370,918 on February 10, 2012 as a continuation of application no. 12/239,001, which issued as the '012 patent. The '760 patent was filed as application no. 13/615,755 on September 14, 2012 as a continuation of application no. 13/370,918, which issued as the '107 patent. The '838 patent was filed as application no. 13/615,734 on September 14, 2012 as a continuation of application no. 13/370,918, which issued as the '107 patent.

36. The specifications of the asserted patents all have the same figures, Summary of the Invention, and for the most part, detailed description sections. The Background of the Invention sections are also the same except for clerical changes to mention the additional related Chrimar patent filings. Where citations below are made to just one of the Patents-in-Suit, they should be considered applicable to all of them since the text and figures are substantially identical, even if line and column numbers may have changed due to re-pagination.

37. The specification acknowledges that the prior art '260 patent already discussed "injecting a low current power signal into each existing communications link" with a "sensor monitor[ing] the returning current flow [to] detect removal of equipment." '012 Patent, 2:12-19. The '260 patent is incorporated by reference. '012 Patent, 2:13-14.

38. The '260 patent discloses the use of 10BASE-T wiring. '260 Patent, 3:34-35.

It also explains how DC current can be sent via a pair of wires:

Wiring schemes of the 10BaseT type are commonly employed to provide data communication lines for electronic computer equipment. In accordance with conventional wiring approaches, data communications link 14 generally includes a plurality of pairs of transmit wires 44 and 46 as well as a plurality of pairs of receive wires (not shown) connected to each of personal computers 12a through 12d. Each pair of transmit wires 44 and 46 are internally coupled to an associated personal computer 12 via one winding 53 of an internally located isolation transformer 52. Each pair of transmit wires 44 and 46 along with isolation transformer 52 thereby form a current loop through the personal computer 12. . .

'260 Patent, 3:35-48.

[A]n isolation power supply 26 [] supplies a continuous direct current (DC) power signal to each of the current loops 50a through 50d.

'260 Patent, 3:53-56.

The power supply lines 28a through 28d each are electrically coupled to respective transmit wires 44a through 44d found within data communication link 14. Receive power lines 30a through 30d are likewise electrically coupled to transmit wires 46a through 46d also found within the data communication link 14. Transmit wires 44a through 44d and 46a through 46d are existing wires found within data communication link 14 that are selectively tapped as pairs in accordance with the present invention to provide current loops 50a through 50d.

As a consequence, power supply line 28a continuously supplies a low current DC power signal to remote personal computer 12a via transmit wire 44a. The lower current power signal flows through an internal path provided by existing circuitry in personal computer 12a. The low current power signal then exits the remote personal computer 12a via transmit wire 46a and in turn is picked up by receive power line 30a. The lower current power signal is continuously supplied to current loops 50a through 50d at all times regardless of whether the computer network 10 or any personal computers 12a through 12d are operating or not. In addition, the very low current DC power signal is so small that it does not interfere with or adversely affect the operation of the associated computers 12a through 12d or computer network 10. To prevent the flow of DC current to or from hub 20, each of the transmit wires 44a through 44d and 46a through 46d are further coupled to DC blocking capacitors C<sub>5</sub> between each of the current loops 50a through 50d and hub 20. DC blocking capacitors C<sub>5</sub> thereby prevent unwanted DC current paths through hub 20.

'260 Patent, 4:15-46.

39. Figure 2 of the '260 patent, highlighted to show a DC current path is shown below:

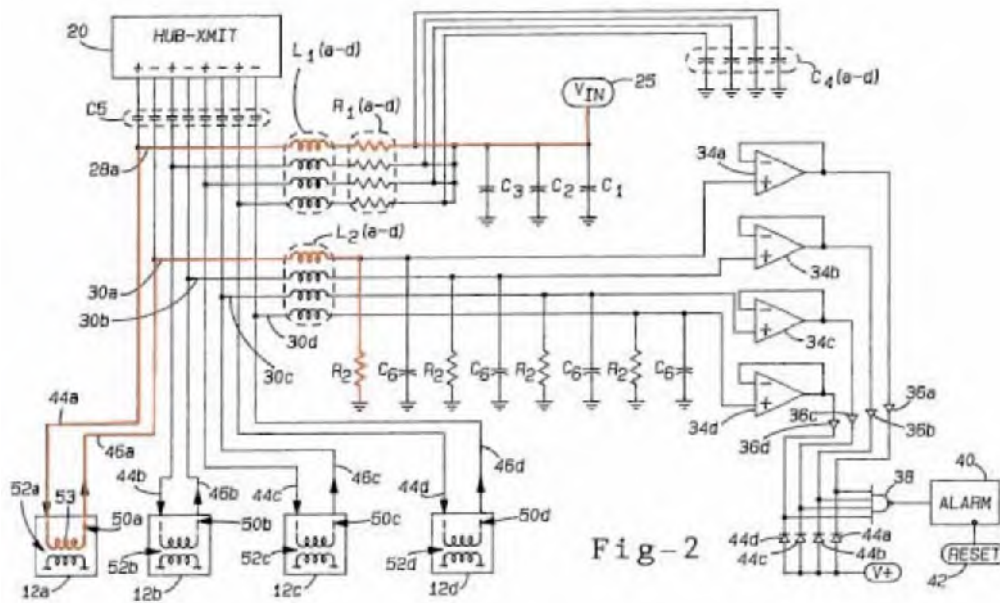

Fig-2

40. As shown above, the current loop path of the '260 patent uses the network side (top half) of the isolation transformer to pass DC current across one pair of transmit wires (44a and 46a). Elements in boxes 12a – 12d show corresponding transformers in the other remote devices in the system, and box 20 is a central hub. Otherwise all of which is shown in the figure relates to a device that sends a low DC current over the existing Ethernet wiring and detects whether the path is present or broken, by the presence (or lack of) current flow in the path.

41. The Patents-in-Suit use the above described scheme to detect the presence or removal of the Ethernet hub or the remote device.

42. The provisional application for the Patents-in-Suit included only block diagrams. What now constitute Figures 4-10 and 16-22 of the Patents-in-Suit were not present in the provisional application. Only the following sections of text in the Patents-in-Suit can be identified in the provisional application: 1:22-53; 1:66-2:2; 2:8-27; 2:30-32; 5:14-32; 5:30-40 (“central module” and “remote module” in Patents-in-Suit specification replacing “network identification receiver” and “network identification circuitry,”

respectively in provisional); 5:53-61; 6:1-3 (“remote module” replaces “network identification circuitry”); 6:7-13; 6:20-31 (“central module” and “remote module” in the ‘012 specification replacing “network identification receiver” and “network identification circuitry,” respectively in provisional); 10:49-11:19 (“remote module” replaces “network identification circuitry”).

43. Figures 4-10, 16-18 first appeared in application no. PCT/US99/07846 filed on April 8, 1999. The text in the ‘012 patent through column 12, line 61, with the exception of the text identified above, was first added in this filing.

44. Figures 19a, 19b, 20, 21, and 22, their accompanying descriptions in the “Brief Description of the Drawings” (4:24-35), and the text from col. 12, line 62 through col. 16, line 64 first appeared in continuation-in-part application no. 09/370,430, filed on August 9, 1999.

45. The specification explains that the “invention relates generally to computer networks and more particularly, to a network management and security system for managing, tracking, and identifying remotely located electronic equipment on the network.” (‘012 patent, 1:23-26.) The objective of the invention is to provide “a method for permanently identifying an asset by attaching an external or internal device to the asset and communicating with that device using existing network wiring or cabling.” ‘012 Patent, 1:66-2-2.

46. The specification of the Patents-in-Suit distinguishes the invention from the ‘260 patent, stating, “It would, however, be desirable to provide a further means in which a networked device may also be identified by a unique identification number using the existing wiring or cabling as a means of communicating this information back to a central location. More particularly, it is desirable to provide a means for identification that feasibly employs the same cable (and if desired, the same wires in the cable) that normally carries high frequency data communications in an existing network.” ‘012 Patent, 2:22-30.

47. The summary of the invention explains that the invention provides a communication system for “generating and monitoring data over a pre-existing wiring or cables that connect pieces of networked computer equipment to a network” and that “a remote module attached to the electronic equipment [] transmits information to a central module by impressing a low frequency signal on the wires of the cable.” ‘012 Patent, 3:18-25.

48. The specification explains that the remote module to be attached to the asset being tracked requires power, which is provided to it by the central module by way of a DC power supply attached to a current loop passing through the network wiring to which remote module and the asset to be tracked are both connected. ‘012 Patent, 5:14-52.

49. The remote module receives the DC current supply and uses it to power the circuitry providing for a “preprogrammed unique identification number,” which is then encoded via a modulation technique, such as Manchester encoding, which is then transmitted back, as a modulation of the DC current signal. ‘012 Patent, 6:9-30.

50. The other embodiments also contemplate the modulation of current to provide an information stream. ‘012 Patent, 8:49-57; 9:47-53; 10:9-25; 12:6-47; 14:21-28.

51. The embodiments disclosed in the specification all incorporate a remote module that draws DC current via one wire of a pair of wires connecting the Ethernet connectors of the central and remote module. The remote module returns the DC current via a different pair with the total DC current split between the two wires of that second pair. The variation in the relative amount of current in the two wires of the second pair provides the manner by which information (the encoded bits) are sent to the central module. *See* ‘012 Patent Figs. 6, 8, 10; and corresponding text.

52. The embodiments do not include any examples in which the (total) DC current drawn by the remote module from the central module provides any information about the remote module, as required by certain claims. *See, e.g.,* ‘107 Patent, Claim 1

("the piece of Ethernet terminal equipment to draw different magnitudes of DC current flow ... to convey information about the piece of Ethernet terminal equipment.") They also do not disclose any examples in which a single magnitude of current drawn by the module is indicative of any feature of the remote module, other than what is already disclosed by the '260 patent.

53. The '012 patent was filed as an application on September 26, 2008. The claims as issued first appear in an amendment dated March 25, 2011. *See* '012 Patent Prosecution History, March 25, 2011 Response.

54. The '107 patent was filed as a continuation of the application that issued as the '012 patent.

55. The prosecution history of the '107 patent is informative as to the meaning of "at least one path coupled across for the purpose of drawing DC current," "current," and "current flow," and the meaning of the use of infinitives in the claims.

56. Claim 1 of the '107 patent as filed is reproduced below:

1. A piece of terminal equipment comprising:  
an Ethernet connector comprising contact 1 through contact 8, specific contacts of the Ethernet connector comprising at least contacts 1, 2, 3 and 6, at least one of the specific contacts of the Ethernet connector disposed to conduct at least one electrical signal into the piece of terminal equipment and at least another one of the specific contacts of the Ethernet connector disposed to conduct the at least one electrical signal out of the piece of terminal equipment; and  
circuitry arranged to utilize the at least one electrical signal to convey distinguishing information about the piece of terminal equipment even if the piece of terminal equipment is powered-off.

'107 Prosecution History at 41 (CMS049925).

57. The Examiner rejected the claims as failing to meet the written description requirement of 35 U.S.C. § 112:

2. Claims 1-71 are rejected under 35 U.S.C. 112(a) or 35 U.S.C. 112 (pre-AIA), first paragraph, as failing to comply with the written description requirement. The claim(s) contains subject matter which was not described in the specification in such a way as to reasonably convey to one skilled in the relevant art that the inventor or a joint inventor, or for pre-AIA the inventor(s), at the time the application was filed, had possession of the claimed invention.

Claim 1 recites "electrical signal to convey distinguishing information about the piece of terminal equipment even if the piece of terminal equipment is powered-off" and claim 7 disclose "distinguishing information comprises a preprogrammed pattern".

The specification discloses in [0010], "The power signal to the communication device may also be fluctuated to provide useful information, such as status information, to the communication device".

The specification lacks how to make the power signal to convey distinguishing information about the terminal equipment. Merely stating power signal fluctuation can be used to convey useful information does enable one skilled in the art to make the pertinent invention.

---

The description also lacks how to make the power signal fluctuation to associate with a preprogrammed pattern to provide the distinguishing information when even the piece of terminal equipment is powered-off.

'107 Prosecution History at 970-71 (CMS050854-55).



58. The Examiner's rejection noted that the specification did not disclose how a power signal would be fluctuated to provide distinguishing information about the piece of terminal equipment.

59. In response, the applicants cancelled all the claims and submitted new claims starting with claim 72, reproduced below:

72. (New) An identifiable piece of Ethernet terminal equipment comprising:  
an Ethernet connector comprising first and second pairs of contacts used to carry Ethernet communication signals,  
at least one path coupled across at least one of the contacts of the first pair of contacts and at least one of the contacts of the second pair of contacts,  
the piece of Ethernet terminal equipment *to draw current via the at least one path* wherein the current comprises information to identify the piece of Ethernet terminal equipment as a particular piece of Ethernet terminal equipment.

'107 Prosecution History at 1047 (CMS050931) (emphasis added).

60. The claimed Ethernet terminal equipment includes at least two pairs of contacts, and a path coupled across at least one contact of each pair. At this point in the claim, all that is disclosed is a topology structure, namely a path that couples between at least one contact in each of two pairs of contacts. There is not yet any claim element indicating whether or what current is or is not present in the path.

61. However, claim 72 further requires that the piece of Ethernet terminal equipment is "to draw current via the at least one path" and that that current "comprises information to identify the piece of Ethernet terminal equipment as a particular piece of Ethernet terminal equipment." These are functional limitations; i.e. they are defined solely by the function that is to be performed by the previously recited structure.

62. Applicants' remarks accompanying claim 72 and its dependents are provided in full below:

Notwithstanding, Applicant notes that newly presented Claims 72 - 163 now claim first and second pairs of contacts of an Ethernet connector used to carry Ethernet communication signals and at least one path coupled across at least one of the contacts of the first pair of contacts and at least one of the contacts of the second pair of contacts. The at least one of the contacts of the first pair and the at least one of the contacts of the second pair referred to as the recited contacts. The identifiable piece of Ethernet terminal equipment to draw current via the at least one path coupled across the recited contacts wherein the current comprises information to identify the piece of Ethernet terminal equipment as a particular piece of Ethernet terminal equipment. Support for the presently claimed subject matter can be found throughout the originally filed specification and drawings of the present application, including Paragraphs [0002], [0008], [0041], [0052] and Figure 8. Reconsideration and withdrawal of the present rejection are requested.

**REJECTION UNDER 35 U.S.C. § 103**

Claims 1-71 stand rejected under 35 U.S.C. § 103(a) as being unpatentable over Davis et al. (U.S. Pat. No. 5,754,764) in view of Blair et al. (U.S. Pat. No. 5,586,273). This rejection is respectfully traversed.

At the outset, Applicant notes that by way of the present Amendment, Claims 1-71 have been cancelled, thereby rendering this rejection moot. Notwithstanding, in an attempt to expedite prosecution, Applicant submits the following comments in connection with Davis et al. and Blair et al.

Specifically, Applicant submits that Davis et al. merely teach that input/output and local area network functions are combined into a single integrated circuit on a single semiconductor. Local area network circuitry and input and output circuitry are both coupled to at least one host system via a common data bus. (Abstract) In some embodiments, Ethernet communications are employed.

However, it should be abundantly clear that Davis et al. are completely silent with regard to "an Ethernet connector comprising first and second pairs of contacts used to carry Ethernet communication signals", the recited contacts of the Ethernet connector (i.e., "at least one path coupled across at least one of the contacts of the first pair of contacts of [the Ethernet connector] and at least one of the contacts of the second pair of contacts [of the Ethernet connector]"), "the piece of Ethernet terminal equipment to draw current via the at least one path [coupled across the recited contacts] wherein the current comprises information to identify the piece of Ethernet terminal equipment as a particular piece of Ethernet terminal equipment" as presently claimed. That is, although Davis et al. note usage of an Ethernet network, Davis et al. are completely silent with

regard to using the at least one path coupled across contacts used to carry Ethernet communication signals, and to draw current via the at least one path coupled across the recited contacts wherein the current comprises information to identify the piece of Ethernet terminal equipment as a particular piece of Ethernet terminal equipment.

Similarly, Blair et al., like Davis et al., merely teach a synchronous communication protocol between synchronous application programs. The Examiner relies on Blair et al. for teaching an RJ45 connector. To this end, Blair et al., *in toto*, states that "the connector 62 is the ISDN standard connector RJ45." Col. 8, lines 47-48. However, Blair et al. are unable to cure the deficiencies of Davis et al. and are completely silent with regard to using the recited contacts of the Ethernet connector, which are also used to carry Ethernet communication signals, to couple a path across to draw current wherein the current comprises information to identify the piece of Ethernet terminal equipment as a particular piece of Ethernet terminal equipment.

For at least these reasons, Davis et al. and Blair et al., singly or in combination, fail to teach or suggest the claimed invention. Reconsideration and withdrawal of this rejection are requested.

'107 Prosecution History at 1065-67 (CMS050949-51).

63. Applicants distinguished over Davis explaining that the claims as amended require "*using the at least one path coupled across contacts used to carry Ethernet communication signals, and to draw current via the at least one path coupled across the recited contacts wherein the current comprises information to identify the piece of Ethernet terminal equipment as a particular piece of Ethernet terminal equipment.*" (emphasis added)

64. Applicants again focused on using the path to draw current when distinguishing the combination of Davis and Blair (conceded as including an Ethernet connector) because Blair allegedly also fails to disclose "*using the recited contacts of the Ethernet connector, which are also used to carry Ethernet communication signals, to couple a path across to draw current wherein the current comprises information to identify the piece of Ethernet terminal equipment.*" *Id.* (emphasis added)

65. Consistent with the remarks, the claims were not amended using the terms "operable to", "capable of", or "configured to." Instead, the functions performed by the Ethernet equipment are defined using the infinitive "to draw [] current."

66. Dependent claims 92 and 107 were introduced at the same time as independent claim 72, all reproduced below:

72. (New) An identifiable piece of Ethernet terminal equipment comprising: an Ethernet connector comprising first and second pairs of contacts used to carry Ethernet communication signals, at least one path coupled across at least one of the contacts of the first pair of contacts and at least one of the contacts of the second pair of contacts, the piece of Ethernet terminal equipment to draw current via the at least one path wherein the current comprises information to identify the piece of Ethernet terminal equipment as a particular piece of Ethernet terminal equipment.

---

92. (New) The identifiable piece of Ethernet terminal equipment of claim 72 wherein the piece of Ethernet terminal equipment to draw different magnitudes of current via the at least one path.

---

107. (New) The identifiable piece of Ethernet terminal equipment of claim 72 wherein the current comprises DC current.

'107 Prosecution History at 1047 (CMS050931), 1050 (CMS050934), 1053 (CMS050937).

67. The Examiner rejected claims 72, 92, and 107 (among others) in view of U.S. Patent No. 5,923,663 ("Bontemps") and in combination with the '260 patent. '107 Prosecution History at 1097-1101 (CMS050981-85).

68. However, the Examiner indicated that then pending claims 93-96, 147-149, and 163 would be allowable if rewritten in independent form including all of the limitations. Those claims are reproduced below:

93. (New) The identifiable piece of Ethernet terminal equipment of claim 92 wherein at least two different magnitudes of the current comprise the information to identify the piece of Ethernet terminal equipment.

94. (New) The identifiable piece of Ethernet terminal equipment of claim 92 wherein the different magnitudes of current comprise a series of magnitudes.

95. (New) The identifiable piece of Ethernet terminal equipment of claim 92 wherein the different magnitudes of current occur at regular intervals.

96. (New) The identifiable piece of Ethernet terminal equipment of claim 92 wherein the different magnitudes of current result from at least one condition applied to the contacts of the Ethernet connector.

---

147. (New) The identifiable piece of Ethernet terminal equipment according to claim 72 wherein the current comprises a first magnitude of current for a first interval followed by a second magnitude of current for a second interval wherein the second magnitude is greater than the first magnitude.

148. (New) The identifiable piece of Ethernet terminal equipment according to claim 147 wherein at least one of the first and second magnitudes of current identifies the piece of Ethernet terminal equipment.

---

149. (New) The identifiable piece of Ethernet terminal equipment of claim 72 wherein a magnitude of the current is part of a detection protocol.

---

163. (New) The identifiable piece of Ethernet terminal equipment according to claims 72 through 162 wherein the current comprises information to identify the piece of Ethernet of terminal equipment as a particular piece of Ethernet terminal equipment with the piece of Ethernet terminal equipment powered-off.

'107 Prosecution History at 1051 (CMS050935), 1059-60 (CMS050943-44), 1062 (CMS050946).

69. Each of the allowable dependent claims require “current” to be present. Claim 93 requires at least two different magnitudes of current. Claim 95 requires different magnitudes of current at regular intervals. Claim 96 requires current resulting from at least one condition applied. Claim 147 requires different magnitudes of current with the larger magnitude occurring second. Claim 148 requires two magnitudes of current, one of which identifying the device. Claim 149 requires a magnitude of current being part of a detection protocol. Claim 163 requires current comprising information.

70. The Examiner deemed these claims allowable not because of any structural limitations in the claim. Rather, they were allowed due to specific limitations requiring current flowing in the accused products.

71. Applicants further amended claim 72 as shown below:

72. (Currently amended) ~~An identifiable~~ A piece of Ethernet terminal equipment comprising:

an Ethernet connector comprising first and second pairs of contacts used to carry Ethernet communication signals, at least one path for the purpose of drawing DC current, the at least one path coupled across at least one of the contacts of the first pair of contacts and at least one of the contacts of the second pair of contacts, the piece of Ethernet terminal equipment to draw different magnitudes of DC current flow via the at least one path, the different magnitudes of DC current flow to result from at least one condition applied to at least one of the contacts of the first and second pairs of contacts, wherein at least one of the magnitudes of the DC current flow to convey comprises information ~~to identify about~~ the piece of Ethernet terminal equipment as a particular ~~piece of Ethernet terminal equipment.~~

‘107 Prosecution History at 1151 (CMS051035) (edits in original).

72. In response to the Examiner’s rejections in view of Bontemps and the ‘260 patent, the applicants added that the “piece of Ethernet terminal equipment to draw current” would also draw “different magnitudes,” that the current was “DC”, and there was current “flow.”