

23.6.2 Link transmission parameters

Unless otherwise specified, link segment testing shall be conducted using source and load impedances of $100\ \Omega$.

23.6.2.1 Insertion loss

The insertion loss of a simplex link segment shall be no more than 12 dB at all frequencies between 2 and 12.5 MHz. This consists of the attenuation of the twisted pairs, connector losses, and reflection losses due to impedance mismatches between the various components of the simplex link segment. The insertion loss specification shall be met when the simplex link segment is terminated in source and load impedances that satisfy 23.5.1.2.4 and 23.5.1.3.3.

NOTE—The loss of PVC-insulated cable exhibits significant temperature dependence. At temperatures greater than $40\ ^\circ\text{C}$, it may be necessary to use a less temperature-dependent cable, such as many Fluorinated Ethylene Propylene (FEP), Polytetrafluoroethylene (PTFE), or Perfluoroalkoxy (PFA) plenum-rated cables.

23.6.2.2 Differential characteristic impedance

The magnitude of the differential characteristic impedance of a 3 m length of twisted pair used in a simplex link shall be between $85\ \Omega$ and $115\ \Omega$ for all frequencies between 2 MHz and 12.5 MHz.

23.6.2.3 Coupling parameters

In order to limit the noise coupled into a simplex link segment from adjacent simplex link segments, Near-End Crosstalk (NEXT) loss and Equal Level Far-End Crosstalk (ELFEXT) loss are specified for each simplex link segment. In addition, since three simplex links (TX_D1, BI_D3, and BI_D4) are used to send data between PHYs and one simplex link (RX_D2) is used to carry collision information as specified in 23.1.4, Multiple-Disturber NEXT loss and Multiple-Disturber ELFEXT loss are also specified.

23.6.2.3.1 Differential Near-End Crosstalk (NEXT) loss

The differential Near-End Crosstalk (NEXT) loss between two simplex link segments is specified in order to ensure that collision information can be reliably received by the PHY receiver. The NEXT loss between each of the three data carrying simplex link segments and the collision sensing simplex link segment shall be at least $24.5 - 15 \times \log_{10}(f/12.5)$ (where f is the frequency in MHz) over the frequency range 2.0 MHz to 12.5 MHz.

23.6.2.3.2 Multiple-disturber NEXT (MDNEXT) loss

Since three simplex links are used to send data between PHYs and one simplex link is used to carry collision information, the NEXT noise that is coupled into the collision, sensing simplex link segment is from multiple (three) signal sources, or disturbers. The MDNEXT loss between the three data carrying simplex link segments and the collision sensing simplex link segment shall be at least $21.4 - 15 \times \log_{10}(f/12.5)$ dB (where f is the frequency in MHz) over the frequency range 2.0 to 12.5 MHz. Refer to 12.7.3.2 and Appendix A3, Example Crosstalk Computation for Multiple Disturbers, for a tutorial and method for estimating the MDNEXT loss for an n-pair cable.

23.6.2.3.3 Equal Level Far-End Crosstalk (ELFEXT) loss

Equal Level Far-End Crosstalk (ELFEXT) loss is specified in order to limit the crosstalk noise at the far end of a simplex link segment to meet the BER objective specified in 23.1.2 and the noise specifications of 23.6.3. Far-End Crosstalk (FEXT) noise is the crosstalk noise that appears at the far end of a simplex link segment which is coupled from an adjacent simplex link segment with the noise source (transmitters) at the near end. ELFEXT loss is the ratio of the data signal to FEXT noise at the output of a simplex link segment (receiver input). To limit the FEXT noise from adjacent simplex link segments, the ELFEXT loss between two data car-

rying simplex link segments shall be greater than $23.1 - 20 \times \log_{10}(f/12.5)$ dB (where f is the frequency in MHz) over the frequency range 2.0 MHz to 12.5 MHz. ELFEXT loss at frequency f and distance l is defined as

$$\text{ELFEXT_Loss}(f,l) = 20 \times \log_{10} \left(\frac{V_{\text{pds}}}{V_{\text{pcn}}} \right) - \text{SLS_Loss} \text{ (dB)}$$

where

V_{pds} is the peak voltage of disturbing signal (near-end transmitter)
 V_{pcn} is the peak crosstalk noise at the far end of disturbed simplex link segment
 SLS_Loss is the insertion loss of the disturbing simplex link segment

23.6.2.3.4 Multiple-disturber ELFEXT (MDELTEXT) loss

Since three simplex links are used to transfer data between PHYs, the FEXT noise that is coupled into a data carrying simplex link segment is from multiple (two) signal sources, or disturbers. The MDELTEXT loss between a data carrying simplex link segment and the other two data carrying simplex link segments shall be greater than $20.9 - 20 \times \log_{10}(f/12.5)$ (where f is the frequency in MHz) over the frequency range 2.0 MHz to 12.5 MHz. Refer to 12.7.3.2 and Appendix A3, Example Crosstalk Computation for Multiple Disturbers, for a tutorial and method for estimating the MDELTEXT loss for an n-pair cable.

23.6.2.4 Delay

Since T4 sends information over three simplex link segments in parallel, the absolute delay of each and the differential delay are specified to comply with network round-trip delay limits and ensure the proper decoding by receivers, respectively.

23.6.2.4.1 Maximum link delay

The propagation delay of a simplex link segment shall not exceed 570 ns at all frequencies between 2.0 MHz and 12.5 MHz.

23.6.2.4.2 Maximum link delay per meter

The propagation delay per meter of a simplex link segment shall not exceed 5.7 ns/m at all frequencies between 2.0 MHz and 12.5 MHz.

23.6.2.4.3 Difference in link delays

The difference in propagation delay, or skew, under all conditions, between the fastest and the slowest simplex link segment in a link segment shall not exceed 50 ns at all frequencies between 2.0 MHz and 12.5 MHz. It is a further functional requirement that, once installed, the skew between all pair combinations due to environmental conditions shall not vary more than ± 10 ns, within the above requirement.

23.6.3 Noise

The noise level on the link segments shall be such that the objective error rate is met. The noise environment consists generally of two primary contributors: self-induced near-end crosstalk, which affects the ability to detect collisions, and far-end crosstalk, which affects the signal-to-noise ratio during packet reception.

23.6.3.1 Near-End Crosstalk

The MDNEXT (Multiple-Disturber Near-End Crosstalk) noise on a link segment depends on the level of the disturbing signals on pairs TX_D1, BI_D3, and BI_D4, and the crosstalk loss between those pairs and the disturbed pair, RX_D2.

The MDNEXT noise on a link segment shall not exceed 325 mVp.

This standard is compatible with the following assumptions:

- a) Three disturbing pairs with 99th percentile pair-to-pair NEXT loss greater than 24.5 dB at 12.5 MHz (i.e., Category 3 cable).
- b) Six additional disturbers (2 per simplex link) representing connectors at the near end of the link segment with 99th percentile NEXT loss greater than 40 dB at 12.5 MHz (i.e., Category 3 connectors installed in accordance with 23.6.4.1).
- c) All disturbers combined according to the MDNEXT Monte Carlo procedure outlined in Appendix A3, Example Crosstalk Computation for Multiple Disturbers.

The MDNEXT noise is defined using three maximum level 100BASE-T4 transmitters sending uncorrelated continuous data sequences while attached to the simplex link segments TX_D1, BI_D3, and BI_D4 (disturbing links), and the noise measured at the output of a filter connected to the simplex link segment RX_D2 (disturbed link). Each continuous data sequence is a pseudo-random bit pattern having a length of at least 2047 bits that has been coded according to the 8B6T coding rules in 23.2.1.2. The filter is the 100BASE-T4 Transmit Test Filter specified in 23.5.1.2.3.

23.6.3.2 Far-End Crosstalk

The MDFEXT (Multiple-Disturber Far-End Crosstalk) noise on a link segment depends on the level of the disturbing signals on pairs TX_D1, BI_D3, and BI_D4, and the various crosstalk losses between those pairs.

The MDFEXT noise on a link segment shall not exceed 87 mVp.

This standard is compatible with the following assumptions:

- a) Two disturbing pairs with 99th percentile ELFEXT (Equal Level Far-End Crosstalk) loss greater than 23 dB at 12.5 MHz.
- b) Nine additional disturbers (three per simplex link) representing connectors in the link segment with 99th percentile NEXT loss greater than 40 dB at 12.5 MHz.
- c) All disturbers combined according to the MDNEXT Monte Carlo procedure outlined in Appendix A3, Example Crosstalk Computation for Multiple Disturbers.

The MDFEXT noise is defined using two maximum level 100BASE-T4 transmitters sending uncorrelated continuous data sequences while attached to two simplex link segments (disturbing links) and the noise measured at the output of a filter connected to the far end of a third simplex link segment (disturbed link). Each continuous data sequence is a pseudo-random bit pattern having a length of at least 2047 bits that has been coded according to the 8B6T coding rules in 23.2.1.2. The filter is the 100BASE-T4 Transmit Test Filter specified in 23.5.1.2.3.

23.6.4 Installation practice

23.6.4.1 Connector installation practices

The amount of untwisting in a pair as a result of termination to connecting hardware should be no greater than 25 mm (1.0 in) for Category 3 cables. This is the same value recommended in ISO/IEC 11801: 1995 for Category 4 connectors.

23.6.4.2 Disallow use of Category 3 cable with more than four pairs

Jumper cables, or horizontal runs, made from more than four pairs of Category 3 cable are not allowed.

23.6.4.3 Allow use of Category 5 jumpers with up to 25 pairs

Jumper cables made from up to 25 pairs of Category 5 cable, for the purpose of mass-terminating port connections at a hub, are allowed. Such jumper cables, if used, shall be limited in length to no more than 10 m total.

23.7 MDI specification

This clause defines the MDI. The link topology requires a crossover function between PMAs. Implementation and location of this crossover are also defined in this clause.

23.7.1 MDI connectors

Eight-pin connectors meeting the requirements of section 3 and figures 1-5 of IEC 603-7: 1990 shall be used as the mechanical interface to the balanced cabling. The plug connector shall be used on the balanced cabling and the jack on the PHY. These connectors are depicted (for informational use only) in figures 23-26 and 23-27. The table 23-6 shows the assignment of PMA signals to connector contacts for PHYs with and without an internal crossover.

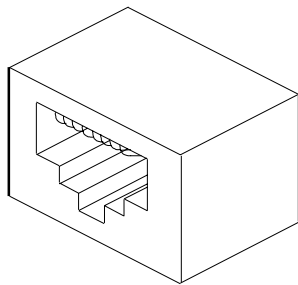

Figure 23-26—MDI connector

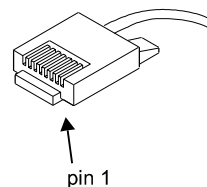

Figure 23-27—Balanced cabling connector

23.7.2 Crossover function

It is a functional requirement that a crossover function be implemented in every link segment. The crossover function connects the transmitters of one PHY to the receivers of the PHY at the other end of the link segment. Crossover functions may be implemented internally to a PHY or elsewhere in the link segment. For a PHY that does not implement the crossover function, the MDI labels in the last column of table 23-4 refer to its own internal circuits (second column). For PHYs that do implement the internal crossover, the MDI labels in the last column of table 23-4 refer to the internal circuits of the remote PHY of the link segment.

Table 23-6—MDI connection and labeling requirements

Contact	PHY without internal crossover (recommended for DTE) internal PMA signals	PHY with internal crossover (recommended for repeater) internal PMA signals	MDI labeling requirement
1	TX_D1+	RX_D2+	TX_D1+
2	TX_D1-	RX_D2-	TX_D1-
3	RX_D2+	TX_D1+	RX_D2+
4	BI_D3+	BI_D4+	BI_D3+
5	BI_D3-	BI_D4-	BI_D3-
6	RX_D2-	TX_D1-	RX_D2-
7	BI_D4+	BI_D3+	BI_D4+
8	BI_D4-	BI_D3-	BI_D4-

Additionally, the MDI connector for a PHY that implements the crossover function shall be marked with the graphical symbol “X”. Internal and external crossover functions are shown in figure 23-28. The crossover function specified here for pairs TX_D1 and RX_D2 is compatible with the crossover function specified in 14.5.2 for pairs TD and RD.

When a link segment connects a DTE to a repeater, it is recommended the crossover be implemented in the PHY local to the repeater. If both PHYs of a link segment contain internal crossover functions, an additional external crossover is necessary. It is recommended that the crossover be visible to an installer from one of the PHYs. When both PHYs contain internal crossovers, it is further recommended in networks in which the topology identifies either a central backbone segment or a central repeater that the PHY furthest from the central element be assigned the external crossover to maintain consistency.

Implicit implementation of the crossover function within a twisted-pair cable, or at a wiring panel, while not expressly forbidden, is beyond the scope of this standard.

23.8 System considerations

The repeater unit specified in clause 27 forms the central unit for interconnecting 100BASE-T4 twisted-pair links in networks of more than two nodes. It also provides the means for connecting 100BASE-T4 twisted-pair links to other 100 Mb/s baseband segments. The proper operation of a CSMA/CD network requires that network size be limited to control round-trip propagation delay as specified in clause 29.

23.9 Environmental specifications

23.9.1 General safety

All equipment meeting this standard shall conform to IEC 950: 1991.

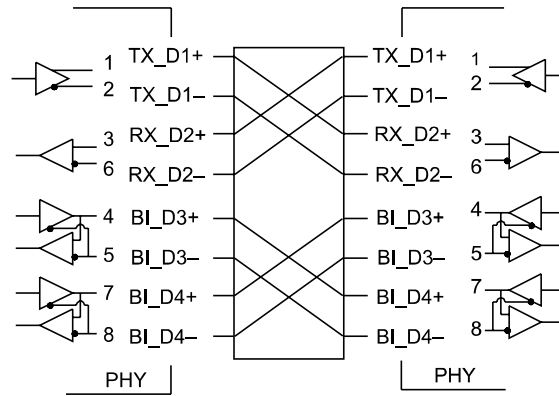

a) Two PHYs with external crossover function

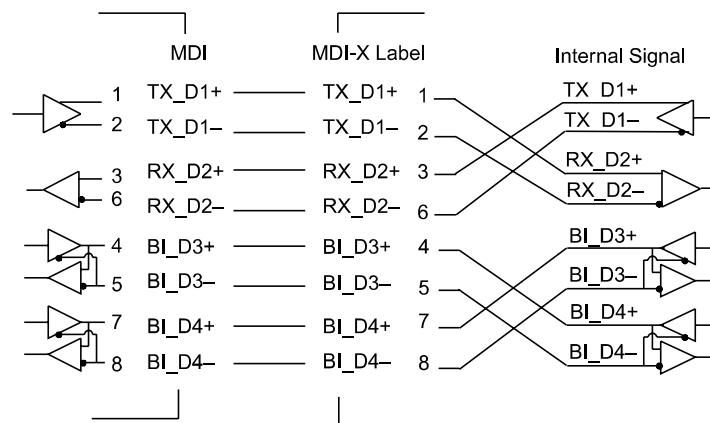

b) PHY with internal crossover function

Figure 23-28—Crossover function

23.9.2 Network safety

This clause sets forth a number of recommendations and guidelines related to safety concerns; the list is neither complete nor does it address all possible safety issues. The designer is urged to consult the relevant local, national, and international safety regulations to ensure compliance with the appropriate requirements.

LAN cable systems described in this clause are subject to at least four direct electrical safety hazards during their installation and use. These hazards are as follows:

- a) Direct contact between LAN components and power, lighting, or communications circuits
- b) Static charge buildup on LAN cables and components
- c) High-energy transients coupled onto the LAN cable system
- d) Voltage potential differences between safety grounds to which various LAN components are connected

Such electrical safety hazards must be avoided or appropriately protected against for proper network installation and performance. In addition to provisions for proper handling of these conditions in an operational system, special measures must be taken to ensure that the intended safety features are not negated during installation of a new network or during modification or maintenance of an existing network.

23.9.2.1 Installation

It is a mandatory functional requirement that sound installation practice, as defined by applicable local codes and regulations, be followed in every instance in which such practice is applicable.

23.9.2.2 Grounding

Any safety grounding path for an externally connected PHY shall be provided through the circuit ground of the MII connection.

WARNING—It is assumed that the equipment to which the PHY is attached is properly grounded, and not left floating nor serviced by a “doubly insulated, ac power distribution system.” The use of floating or insulated equipment, and the consequent implications for safety, are beyond the scope of this standard.

23.9.2.3 Installation and maintenance guidelines

It is a mandatory functional requirement that, during installation and maintenance of the cable plant, care be taken to ensure that noninsulated network cable conductors do not make electrical contact with unintended conductors or ground.

23.9.2.4 Telephony voltages

The use of building wiring brings with it the possibility of wiring errors that may connect telephony voltages to 100BASE-T4 equipment. Other than voice signals (which are low voltage), the primary voltages that may be encountered are the “battery” and ringing voltages. Although there is no universal standard, the following maximums generally apply.

Battery voltage to a telephone line is generally 56 Vdc applied to the line through a balanced 400 Ω source impedance.

Ringing voltage is a composite signal consisting of an ac component and a dc component. The ac component is up to 175 V peak at 20 Hz to 60 Hz with a 100 Ω source resistance. The dc component is 56 Vdc with a 300 Ω to 600 Ω source resistance. Large reactive transients can occur at the start and end of each ring interval.

Although 100BASE-T4 equipment is not required to survive such wiring hazards without damage, application of any of the above voltages shall not result in any safety hazard.

NOTE—Wiring errors may impose telephony voltages differentially across 100BASE-T4 transmitters or receivers. Because the termination resistance likely to be present across a receiver’s input is of substantially lower impedance than an off-hook telephone instrument, receivers will generally appear to the telephone system as off-hook telephones. Therefore, full-ring voltages will be applied for only short periods. Transmitters that are coupled using transformers will similarly appear like off-hook telephones (though perhaps a bit more slowly) due to the low resistance of the transformer coil.

23.9.3 Environment

23.9.3.1 Electromagnetic emission

The twisted-pair link shall comply with applicable local and national codes for the limitation of electromagnetic interference.

23.9.3.2 Temperature and humidity

The twisted-pair link is expected to operate over a reasonable range of environmental conditions related to temperature, humidity, and physical handling (such as shock and vibration). Specific requirements and values for these parameters are considered to be beyond the scope of this standard.

It is recommended that manufacturers indicate in the literature associated with the PHY the operating environmental conditions to facilitate selection, installation, and maintenance.

23.10 PHY labeling

It is recommended that each PHY (and supporting documentation) be labeled in a manner visible to the user with at least these parameters:

- a) Data rate capability in Mb/s
- b) Power level in terms of maximum current drain (for external PHYs)
- c) Any applicable safety warnings

See also 23.7.2.

23.11 Timing summary

23.11.1 Timing references

All MII signals are defined (or corrected to) the DTE end of a zero length MII cable.

NOTE—With a finite length MII cable, TX_CLK appears in the PHY one cable propagation delay *earlier* than at the MII. This advances the transmit timing. Receive timing is retarded by the same amount.

The phrase *adjusted for pair skew*, when applied to a timing reference on a particular pair, means that the designated timing reference has been adjusted by adding to it the difference between the time of arrival of preamble on the latest of the three receive pairs and the time of arrival of preamble on that particular pair.

PMA_UNITDATA request

Figures 23-29, 30, 31, and 32. The implementation of this abstract message is not specified. Conceptually, this is the time at which the PMA has been given full knowledge and use of the ternary symbols to be transmitted.

PMA_UNITDATA.indicate

Figure 23-33. The implementation of this abstract message is not specified. Conceptually, this is the time at which the PCS has been given full knowledge and use of the ternary symbols received.

WAVEFORM

Figure 23-29. Point in time at which output waveform has moved 1/2 way from previous nominal output level to present nominal output level.

TX_EN

Figure 23-30. First rising edge of TX_CLK following the rising edge of TX_EN.

NOT_TX_EN

Figures 23-31 and 32. First rising edge of TX_CLK following the falling edge of TX_EN.

CRS

Figure 23-33. Rising edge of CRS.

CARRIER_STATUS

Figure 23-33. Rising edge of carrier_status.

NOT_CARRIER_STATUS

Figure 23-34. Falling edge of carrier_status.

RX_DV

No figure. First rising edge of RX_CLK following rising edge of RX_DV.

COL

No figure. Rising edge of COL signal at MII.

NOT_COL

No figure. Falling edge of COL signal at MII.

PMA_ERROR

No figure. Time at which rxerror_status changes to ERROR.

23.11.2 Definitions of controlled parameters**PMA_OUT**

Figure 23-29. Time between PMA_UNITDATA request (tx_code_vector) and the WAVEFORM timing reference for each of the three transmit channels TX_D1, BI_D3, or BI_D4.

TEN_PMA

Figures 23-30, 31, and 32. Time between TX_EN timing reference and MA_UNITDATA request (tx_code_vector).

TEN_CRS

Figure 23-30. Time between TX_EN timing reference and the loopback of TX_EN to CRS as measured at the CRS timing reference point.

NOT_TEN_CRS

Figures 23-31 and 32. Time between NOT_TX_EN timing reference and the loopback of TX_EN to CRS as measured at the NOT_CRS timing reference point. In the event of a collision (COL is raised at any point during a packet) the minimum time for NOT_TEN_CRS may optionally be as short as 0.

RX_PMA_CARRIER

Figure 23-33. Time between the WAVEFORM timing reference, adjusted for pair skew, of first pulse of a normal preamble (or first pulse of a preamble preceded by a link test pulse or a partial link test pulse) and the CARRIER_STATUS timing reference.

RX_CRS

Figure 23-33. Time between the WAVEFORM timing reference, adjusted for pair skew, of first pulse of a normal preamble (or first pulse of a preamble preceded by a link test pulse or a partial link test pulse) and the CRS timing reference.

NOTE—The input waveform used for this test is an ordinary T4 preamble, generated by a compliant T4 transmitter. As such, the delay between the first and third pulses of the preamble (which are used by the carrier sense logic) is very nearly 80 ns.

RX_NOT_CRS

For a data packet, the time between the WAVEFORM timing reference, adjusted for pair skew, of the first pulse of eop1, and the de-assertion of CRS. For a collision fragment, the time between the WAVEFORM timing reference, adjusted for pair skew, of the ternary symbol on pair TX_D2, which follows the last ternary data symbol received on pair RX_D2, and the de-assertion of CRS.

Both are limited to the same value. For a data packet, detection of the six ternary symbols of eop1 is accomplished in the PCS layer. For a collision fragment, detection of the concluding seven ternary zeroes is accomplished in the PMA layer, and passed to the PCS in the form of the carrier_status indication.

FAIRNESS

The difference between RX_NOT_CRS at the conclusion of one packet and RX_CRS on a subsequent packet. The packets used in this test may arrive with an IPG anywhere in the range of 80 to 160.

RX_PMA_DATA

Figure 23-33. Time between the WAVEFORM timing reference, adjusted for pair skew, of first pulse of a normal preamble (or first pulse of a preamble preceded by a link test pulse or a partial link test pulse) and the particular PMA_UNITDATA.indicate that transfers to the PCS the first ternary symbol of the first 6T code group from receive pair BI_D3.

EOP_CARRIER_STATUS

Figure 23-34. For a data packet, the time between the WAVEFORM timing reference, adjusted for pair skew, of first pulse of eop1 and the NOT_CARRIER_STATUS timing reference.

EOC_CARRIER_STATUS

Figure 23-35. In the case of a colliding packet, the time between the WAVEFORM timing reference, adjusted for pair skew, of the ternary symbol on pair RX_D2, which follows the last ternary data symbol received on pair RX_D2 and the NOT_CARRIER_STATUS timing reference.

RX_RXDV

No figure. Time between WAVEFORM timing reference, adjusted for pair skew, of first pulse of a normal preamble (or first pulse of a preamble preceded by a link test pulse or a partial link test pulse) and the RX_DV timing reference.

RX_PMA_ERROR

No figure. In the event of a preamble in error, the time between the WAVEFORM timing reference adjusted for pair skew, of first pulse of that preamble (or first pulse of the preamble preceded by a link test pulse or a partial link test pulse), and the PMA_ERROR timing reference.

RX_COL

No figure. In the event of a collision, the time between the WAVEFORM timing reference adjusted for pair skew, of first pulse of a normal preamble (or first pulse of a preamble preceded by a link test pulse or a partial link test pulse), and the COL timing reference.

RX_NOT_COL

No figure. In the event of a collision in which the receive signal stops before the locally transmitted signal, the time between the WAVEFORM timing reference adjusted for pair skew, of the ternary symbol on pair RX_D2, which follows the last ternary data symbol received on pair RX_D2 and the NOT_COL timing reference point.

TX_NOT_COL

No figure. In the event of a collision in which the locally transmitted signal stops before the received signal, the time between the NOT_TX_EN timing reference and the loopback of TX_EN to COL as measured at the NOT_COL timing reference point.

TX_SKEW

Greatest absolute difference between a) the waveform timing reference of the first pulse of a preamble as measured on output pair TX_D1; b) the waveform timing reference of the first pulse of a preamble as measured on output pair BI_D3; and c) the waveform timing reference of the first pulse of a preamble as measured on output pair BI_D4. Link test pulses, if present during the measurement, must be separated from the preamble by at least 100 ternary symbols.

CRS_PMA_DATA

Time between the timing reference for CARRIER STATUS and the transferral, via PMA_UNITDATA.indicate, of the first ternary symbol of the 6T code group marked DATA1 in figure 23-6.

COL_to_BI_D3/D4_OFF

No figure. In the case of a colliding packet, the time between the WAVEFORM timing reference, adjusted for pair skew, of the first pulse of preamble (or the first pulse of the preamble preceded by a link test pulse or a partial link test pulse) on RX_D2, and the first ternary zero transmitted on BI_D3 and on BI_D4.

NOTE—Subclause 23.4.1.2 mandates that transmission on pairs BI_D3 and BI_D4 be halted in the event of a collision.

23.11.3 Table of required timing values

While in the LINK_PASS state, each PHY timing parameter shall fall within the Low and High limits listed in table 23-7. All units are in bit times. A bit time equals 10 ns.

Table 23-7—Required timing values

Controlled parameter	Low limit (bits)	High limit (bits)	Comment
PMA_OUT	1	9.5	
TEN_PMA + PMA_OUT	7	17.5	
TEN_CRIS	0	+4	
NOT_TEN_CRIS	0	36	
RX_PMA_CARRIER	0	15.5	
RX_CRIS	0	27.5	
RX_NOT_CRIS	0	51.5	
FAIRNESS	0	28	
RX_PMA_DATA	67	90.5	
EOP_CARRIER_STATUS	51	74.5	
EOC_CARRIER_STATUS	3	50.5	
RX_RXDV	81	114.5	
RX_PMA_ERROR	RX_PMA_DATA	RX_PMA_DATA + 20	Allowed limits equal the actual RX_PMA_DATA time for the device under test plus from 0 to 20 BT
RX_COL	0	27.5	SAME AS RX_CRIS
RX_NOT_COL	0	51.5	SAME AS RX_NOT_CRIS
TX_NOT_COL	0	36	
TX_SKEW	0	0.5	
CRS_PMA_DATA	0	78.5	
COL_to_BI_D3/D4_OFF	0	40	

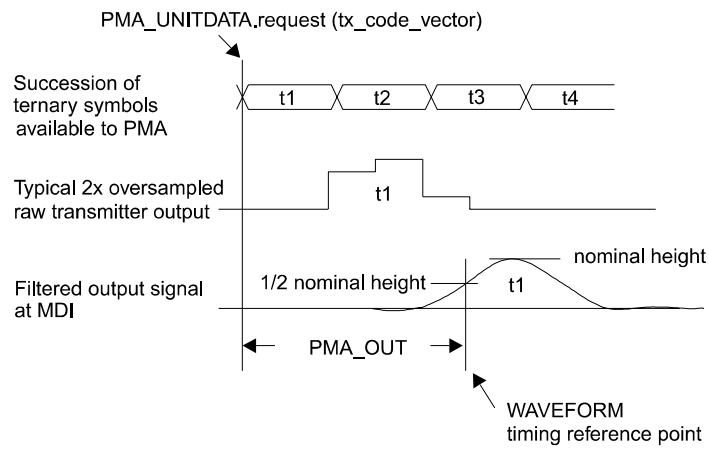

Figure 23-29—PMA TRANSMIT timing while tx_code_vector = DATA

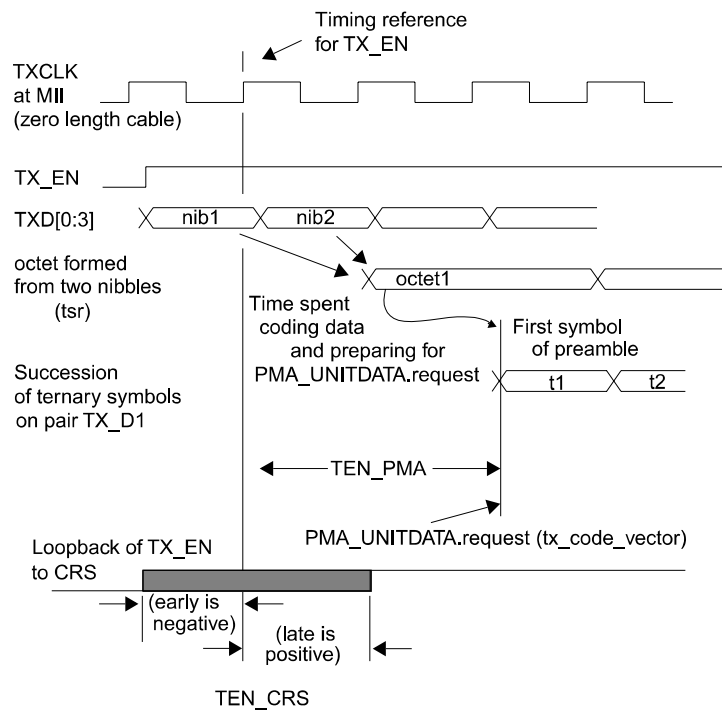

Figure 23-30—PCS TRANSMIT timing at start of packet

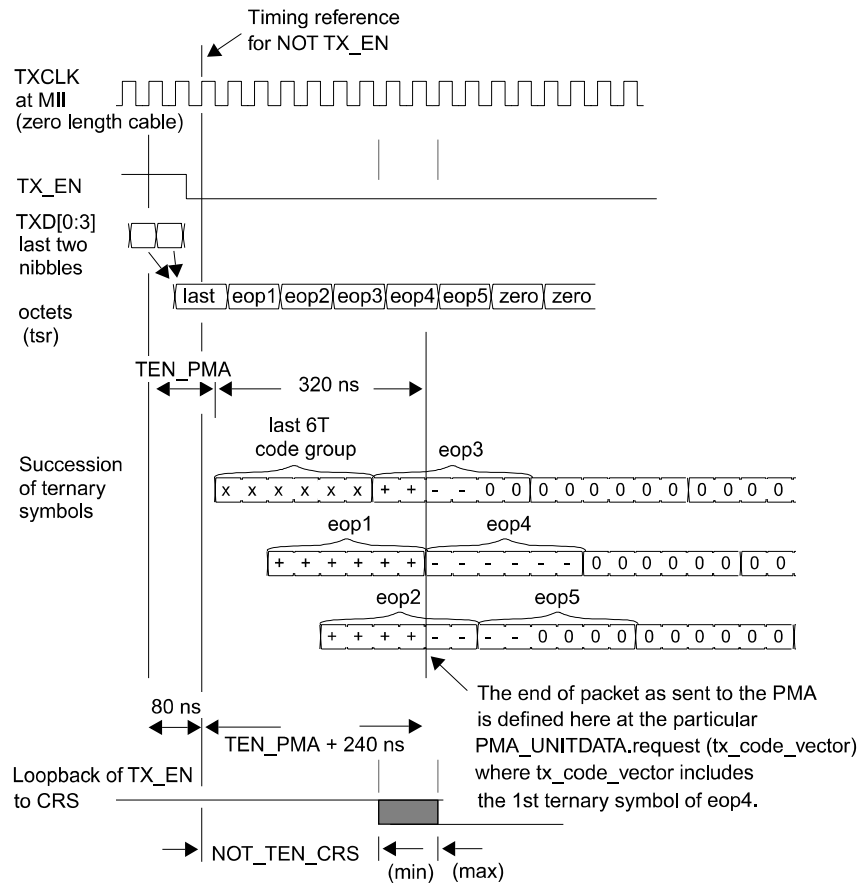

Figure 23-31—PCS TRANSMIT timing end of normal packet

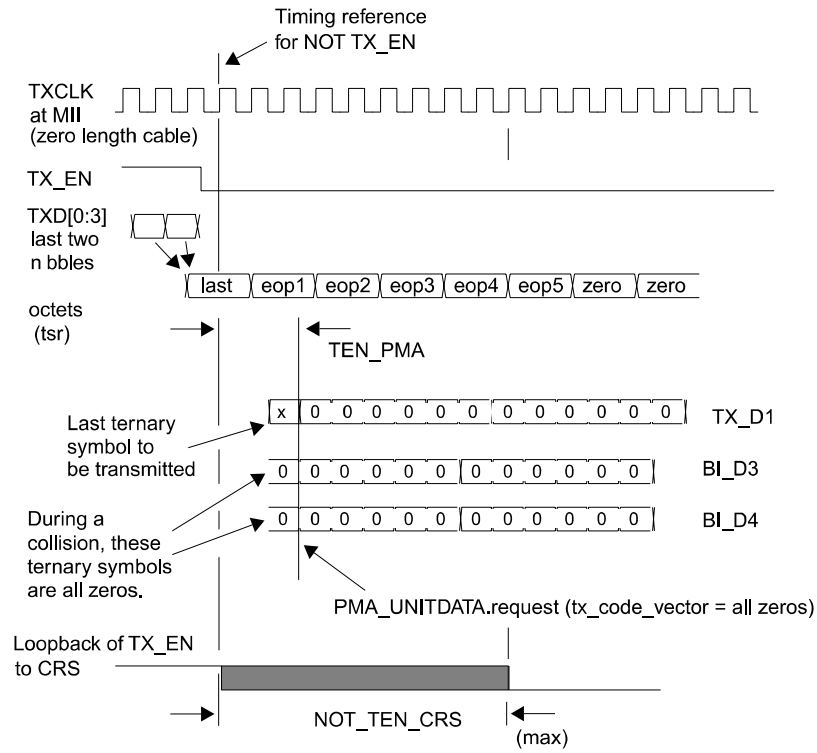

Figure 23-32—PCS TRANSMIT timing end of colliding packet

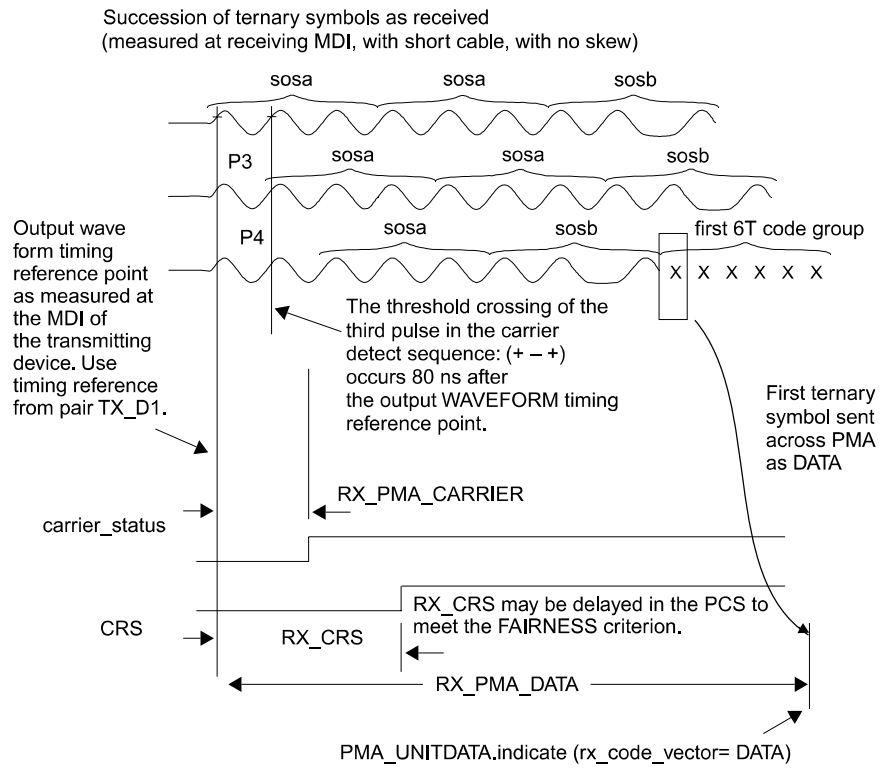
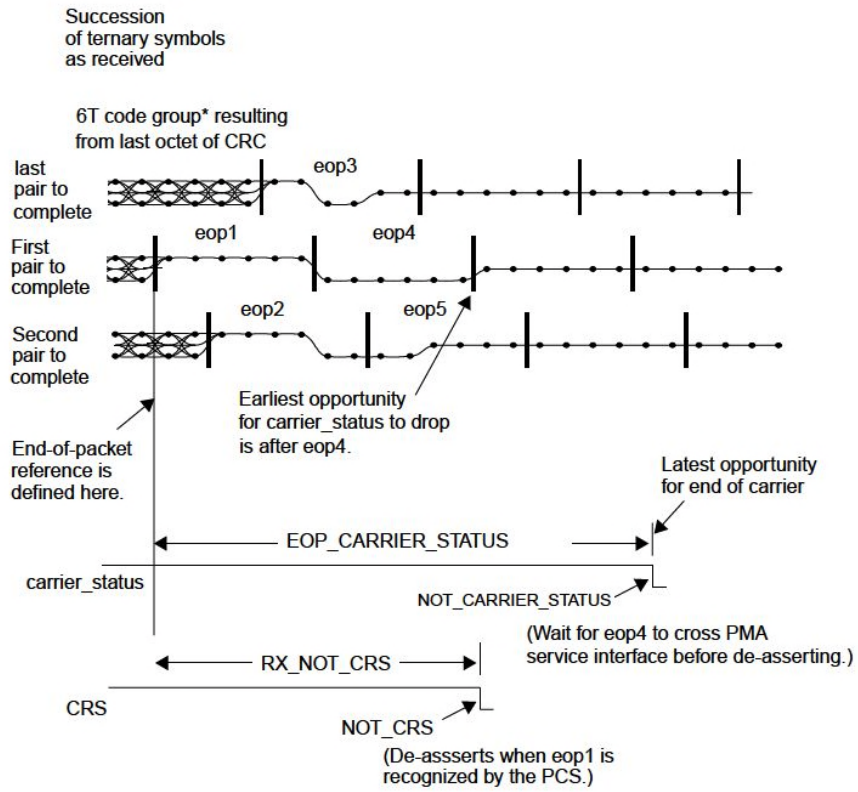

Figure 23-33—PMA RECEIVE timing start of packet



*RX_DV de-asserts after sending the last nibble of this decoded octet across the MII. CRS may de-assert prior to that time.

Figure 23-34—PMA RECEIVE timing end of normal packet

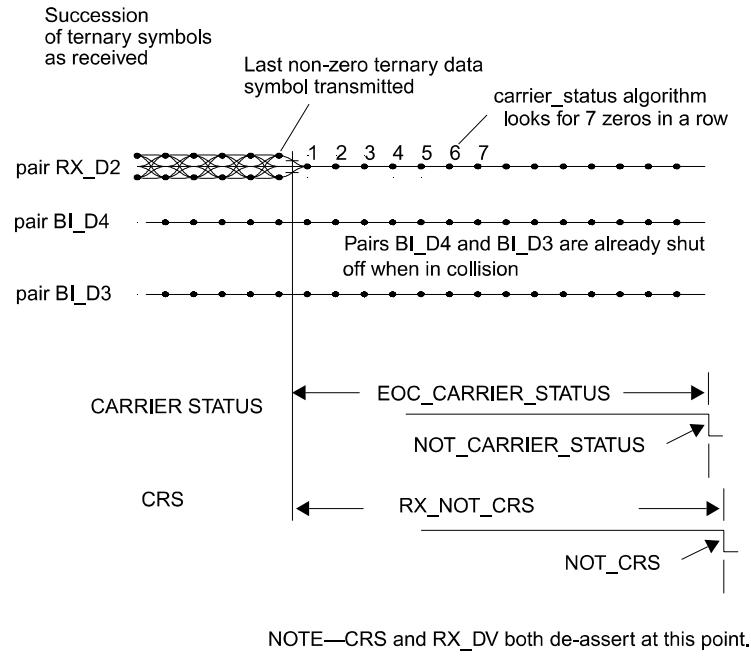

Figure 23-35—PMA RECEIVE timing end of colliding packet

23.12 Protocol Implementation Conformance Statement (PICS) proforma for clause 23, Physical Coding Sublayer (PCS), Physical Medium Attachment (PMA) sublayer and baseband medium, type 100BASE-T4²⁸

23.12.1 Introduction

The supplier of a protocol implementation that is claimed to conform to clause 23, Physical Coding Sublayer (PCS), Physical Medium Attachment (PMA) sublayer and baseband medium, type 100BASE-T4, shall complete the following Protocol Implementation Conformance Statement (PICS) proforma.

A detailed description of the symbols used in the PICS proforma, along with instructions for completing the PICS proforma, can be found in clause 21.

23.12.2 Identification

23.12.2.1 Implementation identification

Supplier	
Contact point for enquiries about the PICS	
Implementation Name(s) and Version(s)	
Other information necessary for full identification—e.g., name(s) and version(s) for machines and/or operating systems; System Names(s)	
<p>NOTES</p> <p>1—Only the first three items are required for all implementations; other information may be completed as appropriate in meeting the requirements for the identification.</p> <p>2—The terms Name and Version should be interpreted appropriately to correspond with a supplier’s terminology (e.g., Type, Series, Model).</p>	

23.12.2.2 Protocol summary

Identification of protocol standard	IEEE Std 802.3, 1998 Edition, clause 23, Physical Coding Sublayer (PCS), Physical Medium Attachment (PMA) sublayer and baseband medium, type 100BASE-T4
Identification of amendments and corrigenda to this PICS proforma that have been completed as part of this PICS	
Have any Exception items been required? (See clause 21; the answer Yes means that the implementation does not conform to IEEE Std 802.3, 1998 Edition.)	No [] Yes []
Date of Statement	

²⁸Copyright release for PICS proformas Users of this standard may freely reproduce the PICS proforma in this annex so that it can be used for its intended purpose and may further publish the completed PICS.

23.12.3 Major capabilities/options

Item	Feature	Subclause	Status	Support	Value/Comment
*MII	Exposed MII interface	23.1.5.3	O		Devices supporting this option must also support the PCS option
*PCS	PCS functions	23.1.5.2	O		Required for integration with DTE or MII
*PMA	Exposed PMA service interface	23.1.5.2	O		Required for integration into symbol level repeater core
*XVR	Internal wiring crossover	23.7.2	O		Usually implemented in repeater, usually not in DTE
*NWY	Support for optional Auto-Negotiation (clause 28)	23.1.5.6	O		Required if Auto-Negotiation is implemented
*INS	Installation / cable		O		Items marked with INS include installation practices and cable specifications not applicable to a PHY manufacturer

23.12.4 PICS proforma tables for the Physical Coding Sublayer (PCS), Physical Medium Attachment (PMA) sublayer and baseband medium, type 100BASE-T4

23.12.4.1 Compatibility considerations

Item	Feature	Subclause	Status	Support	Value/Comment
CCO-1	Compatibility at the MDI	23.1.5.1	M		

23.12.4.2 PCS Transmit functions

Item	Feature	Subclause	Status	Support	Value/Comment
PCT-1	PCS Transmit function	23.2.1.2	PCS:M		Complies with state diagram figure 23-8
PCT-2	Data encoding	23.2.1.2	PCS:M		8B6T with DC balance encoding rules
PCT-3	Order of ternary symbol transmission	Appendix 23-A	PCS:M		Leftmost symbol of each 6T code group first

23.12.4.3 PCS Receive functions

Item	Feature	Subclause	Status	Support	Value/Comment
PCR1	PCS Receive function	23.2.1.3	PCS:M		Complies with state diagram figure 23-9
PCR2	Value of RXD<3:0> while RXDV is de-asserted	23.2.1.3	PCS:M		All zeroes
PCR3	Data decoding	23.2.1.3	PCS:M		8B6T with error detecting rules
PCR4	Value of dc_balance_error, eop_error and codeword_error at times other than those specified in the error detecting rules.	23.2.1.3	PCS:M		OFF
PCR5	Codeword_error indication sets RX_ER when	23.2.1.3	PCS:M		During transfer of both affected data nibbles across the MII
PCR6	Dc_balance_error sets RX_ER when	23.2.1.3	PCS:M		During transfer of both affected nibbles across the MII
PCR7	Eop_error sets RX_ER when	23.2.1.3	PCS:M		During transfer of last decoded data nibble across the MII
PCR8	Action taken if carrier_status is truncated dur to early de-assertion of carrier_status	23.2.1.3	PCS:M		Assert RX_ER, and then de-assert RX_DV

23.12.4.4 Other PCS functions

Item	Feature	Subclause	Status	Support	Value/Comment
PCO1	PCS Reset function executed when	23.2.1.1	PCS:M		Power-on, or the receipt of a reset request from the management entity
PCO2	PCS Error Sense function	23.2.1.4	PCS:M		Complies with state diagram figure 23-10
PCO3	Signaling of RX_ER to MII	23.2.1.4	PCS:M		Before last nibble of clause 4 MAC frame has passed across MII
PCO4	Timing of rxerror_status	23.2.1.4	PCS:M		Causes RX_ER to appear on the MII no later than last nibble of first data octet
PCO5	PCS Carrier Sense function	23.2.1.5	PCS:M		Controls MII signal CRS according to rules in 23.2.1.5
PCO6	MII signal COL is asserted when	23.2.1.6	PCS:M		Upon detection of a PCS collision
PCO7	At other times COL remains	23.2.1.6	PCS:M		De-asserted
PCO8	Loopback implemented in accordance with 22.4.1.2	23.2.2.4	PCS:M		Redundantly specified in 22.2.4.1.2

Item	Feature	Subclause	Status	Support	Value/Comment
PCO9	No spurious signals emitted on the MDI during or after power down	23.2.2.4	M		
PCO10	PMA frame structure	23.2.3	M		Conformance to figure 23-6
PCO11	PMA_UNITDATA messages	23.2.3	PMA:M		Must have a clock for both directions

23.12.4.5 PCS state diagram variables

Item	Feature	Subclause	Status	Support	Value/Comment
PCS1	Timing of eop adjusted such that the last nibble sent across the MII with RX_DV asserted is	23.2.4.1.5	PCS:M		Last nibble of last decoded data octet in a packet
PCS2	Transmission of octets on the three transmit pairs	23.2.4.1.8	PCS:M		Transmission order is: TX_D1, then BI_D3, and then BI_D4
PCS3	Value of tsr during first 16 TX_CLK cycles after TX_EN is asserted	23.2.4.1.11	PCS:M		sosa, sosa, sosa, sosa, sosa, sosa, sosa, sosa, sosa, sosa, sosb, sosb, sosb, sosb, sosb, sosb
PCS4	Value of tsr during first 10 TX_CLK cycles after TX_EN is de-asserted	23.2.4.1.11	PCS:M		eop1, eop1, eop2, eop2, eop3, eop3, eop4, eop4, eop5, eop5
PCS5	TX_ER causes transmission of	23.2.4.1.11	PCS:M		bad_code
PCS6	TX_ER received during the first 16 TX_CLK cycles causes	23.2.4.1.11	PCS:M		Transmission of bad_code during 17th and 18th clock cycles
PCS7	Action taken in event TX_EN falls on an odd nibble boundary	23.2.4.1.11	PCS:M		Extension of TX_EN by one TX_CLK cycle, and transmission of bad_code
PCS8	Transmission when TX_EN is not asserted	23.2.4.1.11	PCS:M		zero_code
PCS9	TX_CLK generated synchronous to	23.2.4.1.12	PCS:M		tw1_timer

23.12.4.6 PMA service interface

Item	Feature	Subclause	Status	Support	Value/Comment
PMS1	Continuous generation of PMA_TYPE	23.3.1.2	M		
PMS2	Generation of PMA_UNITDATA.indicate (DATA) messages	23.3.3.2	M		synchronous with data received at the MDI
PMS3	Generation of PMA_CARRIER.indicate message	23.3.4.2	M		ON/OFF
PMS4	Generation of PMA_LINK.indicate message	23.3.5.2	M		FAIL/READY/OK
PMS5	Link_control defaults on power-on or reset to	23.3.6.2	M		ENABLE
PMS6	Action taken in SCAN_FOR_CARRIER mode	23.3.6.4	NWY:M		Enables link integrity state diagram, but blocks passage into LINK_PASS
PMS7	Reporting of link_status while in SCAN_FOR_CARRIER mode	23.3.6.4	NWY:M		FAIL / READY
PMS8	Reporting of link_status while in DISABLE mode	23.3.6.4	NWY:M		FAIL
PMS9	Action taken in ENABLE mode	23.3.6.4	NWY:M		enables data processing functions
PMS10	Generation of PMA_RXERROR	23.3.7.2	M		ERROR / NO_ERROR

23.12.4.7 PMA Transmit functions

Item	Feature	Subclause	Status	Support	Value/Comment
PMT1	Transmission while (tx_code_vector=DATA) * (pma_carrier=OFF)	23.4.1.2	M		tx_code_vector[TX_D1] tx_code_vector[B1_D3] tx_code_vector[B1_D4]
PMT2	Transmission from time (tx_code_vector=DATA) * (pma_carrier=ON), until (tx_code_vector=IDLE)	23.4.1.2	M		tx_code_vector[TX_D1] CS0 CS0
PMT3	Transmission while tx_code_vector=IDLE	23.4.1.2	M		Idle signal TP_DIL_100
PMT4	Duration of silence between link test pulses	23.4.1.2	M		1.2 ms ± 0.6 ms
PMT5	Link test pulse composed of	23.4.1.2	M		CS-1, CS1 transmitted on TX_D1

Item	Feature	Subclause	Status	Support	Value/Comment
PMT6	Following a packet, TP_IDL_100 signal starts with	23.4.1.2	M		Period of silence
PMT7	Effect of termination of TP_IDL_100	23.4.1.2	M		No delay or corruption of subsequent packet
PMT8	Zero crossing jitter of link test pulse	23.4.1.2	M		Less than 4 ns p-p
PMT9	Action taken when xmit=disable	23.4.1.2	M		Transmitter behaves as if tx_code_vector=IDLE

23.12.4.8 PMA Receive functions

Item	Feature	Subclause	Status	Support	Value/Comment
PMR1	Reception and translation of data with ternary symbol error rate less than	23.4.1.3	M		One part in 10 ⁸
PMR2	Assertion of pma_carrier=ON upon reception of test signal	23.4.1.4	M		Test signal is a succession of three data values, produced synchronously with a 25 MHz clock, both preceded and followed by 100 symbols of silence. The three values are: 467 mV, -225 mV, and then 467 mV again
PMR3	condition required to turn off pma_carrier	23.4.1.4	M		Either of a) Seven consecutive zeroes b) Reception of eop1 per 23.4.1.4
PMR4	Value of carrier_status while rcv=ENABLE	23.4.1.4	M		pma_carrier
PMR5	Value of carrier_status while rcv=DISABLE	23.4.1.4	M		OFF

23.12.4.9 Link Integrity functions

Item	Feature	Subclause	Status	Support	Value/Comment
LIF1	Link Integrity function complies with	23.4.1.5	M		State diagram figure 23-12

23.12.4.10 PMA Align functions

Item	Feature	Subclause	Status	Support	Value/Comment
ALN1	Generation of PMA_UNITDATA.indicate (PREAMBLE) messages	23.4.1.6	M		
ALN2	Ternary symbols transferred by first PMA_UNITDATA.indicate (DATA) message	23.4.1.6	M		rx_code_vector[BI_D3]:first ternary symbol of first data code group rx_code_vector[RX_D2]:two ternary symbols prior to start of second data code group rx_code_vector[BI_D4]:four ternary symbols prior to start of third data code group

Item	Feature	Subclause	Status	Support	Value/Comment
ALN3	PMA_UNITDATA.indicate (DATA) messages continue until carrier_status=OFF	23.4.1.6	M		
ALN4	While carrier_status=OFF, PMA emits message	23.4.1.6	M		PMA_UNITDATA.indicate (IDLE)
ALN5	Failure to recognize SSD generates rxerror_status=ERROR	23.4.1.6	M		
ALN6	Action taken when carrier_status=OFF	23.4.1.6	M		Clear rxerror_status
ALN7	Action taken if first packet is used for alignment	23.4.1.6	M		PMA emits PMA_UNITDATA.indicate (PREAMBLE)
ALN8	Tolerance of line skew	23.4.1.6	M		60 ns
ALN9	Detection of misplaced sosb 6T code group caused by 3 or fewer ternary symbols in error	23.4.1.6	M		
ALN10	Action taken if rcv =disable	23.4.1.6	M		PMA emits PMA_UNITDATA.indicate (IDLE)

23.12.4.11 Other PMA functions

Item	Feature	Subclause	Status	Support	Value/Comment
PMO1	PMA Reset function	23.4.1.1	M		
PMO2	Suitable clock recovery	23.4.1.7	M		

23.12.4.12 Isolation requirements

Item	Feature	Subclause	Status	Support	Value/Comment
ISO1	Values of all components used in test circuits	23.5	M		Accurate to within $\pm 1\%$ unless required otherwise
ISO2	Electrical isolation meets	23.5.1.1	M		1500 V at 50–60 Hz for 60 s per IEC 950: 1991 <i>or</i> 2250 Vdc for 60 s per IEC 950: 1991 <i>or</i> Ten 2400 V pulses per IEC 60
ISO3	Insulation breakdown during isolation test	23.5.1.1	M		None per IEC 950: 1991
ISO4	Resistance after isolation test	23.5.1.1	M		At least 2 M Ω

23.12.4.13 PMA electrical requirements

Item	Feature	Subclause	Status	Support	Value/Comment
PME1	Conformance to all transmitter specifications in 23.5.1.2	23.5.1.2	M		
PME2	Transmitter load unless otherwise specified	23.5.1.2	M		100 Ω
PME3	Peak differential output voltage	23.5.1.2.1	M		3.15–3.85 V
PME4	Differential transmit template at MDI	23.5.1.2.2	M		Table 23-2
PME5	Differential MDI output template voltage scaling	23.5.1.2.2	M		3.15– 3.85 V
PME6	Interpolation between points on transmit template	23.5.1.2.2	M		Linear
PME7	Differential link pulse template at MDI	23.5.1.2.2	M		Table 23-2
PME8	Differential link pulse template scaling	23.5.1.2.2	M		Same value as used for differential transmit template scaling
PME9	Interpolation between point on link pulse template	23.5.1.2.2	M		Linear
PME10	State when transmitting seven or more consecutive CS0 during TP_IDL-100 signal	23.5.1.2.2	M		–50 mV to 50 mV
PME11	Limit on magnitude of harmonics measured at MDI	23.5.1.2.2	M		27 dB below fundamental
PME12	Differential output ISI	23.5.1.2.3	M		Less than 9%
PME13	Measurement of ISI and peak-to-peak signal voltage	23.5.1.2.3	M		Halfway between nominal zero crossing of the observed eye pattern
PME14	Transfer function of 100BASE-T4 transmit test filter	23.5.1.2.3	M		Third-order Butterworth filter with –3 dB point at 25.0 MHz
PME15	Reflection loss of 100BASE-T4 transmit test filter and 100 W load across the frequency range 2–12.5 MHz	23.5.1.2.3	M		Exceeds 17 dB
PME16	Differential output impedance	23.5.1.2.4	M		Provide return loss into 100 Ω of 17 dB from 2.0 to 12.5 MHz
PME17	Maintenance of return loss	23.5.1.2.4	M		At all times PHY is fully powered
PME18	Droop as defined in figure 23-18 during transmission of eop1 and eop4	23.5.1.2.4	M		Less than 6%
PME19	Output timing jitter	23.5.1.2.5	M		No more than 4 ns peak-to-peak

Item	Feature	Subclause	Status	Support	Value/Comment
PME20	Measurement of output timing jitter	23.5.1.2.5	M		Other transmit outputs connected to 100BASE-T4 ISI test filter or 100 Ω load
PME21	Minimum transmitter impedance balance	23.5.1.2.6	M		$29 - 17 \log\left(\frac{f}{10}\right)$ dB
PME22	Transmitter common-mode rejection; effect of E_{cm} as shown in figure 23-20 upon E_{dif}	23.5.1.2.8	M		Less than 100 mV
PME23	Transmitter common-mode rejection; effect of E_{cm} as shown in figure 23-20 upon edge jitter	23.5.1.2.8	M		Less than 1.0 ns
PME24	E_{cm} used for common-mode rejection tests	23.5.1.2.8	M		15 V peak, 10.1 MHz sine wave
PME25	Transmitter faults; response to indefinite application of short circuits	23.5.1.2.9	M		Withstand without damage and resume operation after fault is removed
PME26	Transmitter faults; response to 1000 V common-mode impulse per IEC 60	23.5.1.2.9	M		Withstand without damage
PME27	Shape of impulse used for common-mode impulse test	23.5.1.2.9	M		0.3/50 μ s as defined in IEC 60
PME28	Ternary symbol transmission rate	23.5.1.2.10	M		25.000 MHz \pm 0.01%
PME29	Conformance to all receiver specifications in 23.5.1.3	23.5.1.3	M		
PME30	Action taken upon receipt of differential signals that were transmitted within the constraints of 23.5.1.2 and have passed through worst-case UTP model	23.5.1.3.1	M		Correctly translated into PMA_UNITDATA messages
PME31	Action taken upon receipt of link test pulse	23.5.1.3.1	M		Accept as a link test pulse
PME32	Test configuration for data reception and link test pulse tests	23.5.1.3.1	M		Using worst-case UTP model, and with a connection less than one meter in length
PME33	Bit loss	23.5.1.3.2	M		No more than that specified in 23.5.1.3.1
PME34	Reaction of pma_carrier to signal less than 325 mV peak	23.5.1.3.2	M		Must not set pma_carrier=ON
PME35	Reaction of pma_carrier to continuous sinusoid less than 1.7 MHz	23.5.1.3.2	M		Must not set pma_carrier=ON
PME36	Reaction of pma_carrier to single cycle or less	23.5.1.3.2	M		Must not set pma_carrier=ON

Item	Feature	Subclause	Status	Support	Value/Comment
PME37	Reaction of pma_carrier to fast link pulse as defined in clause 28	23.5.1.3.2	M		Must not set pma_carrier=ON
PME38	Reaction of pma_carrier to link integrity test pulse signal TP_IDL_100	23.5.1.3.2	M		Must not set pma_carrier=ON
PME39	Differential input impedance	23.5.1.3.3	M		Provide return loss into 100 Ω of 17 dB from 2.0 to 12.5 MHz
PME40	Maintenance of return loss	23.5.1.3.3	M		At all times PHY is fully powered
PME41	Droop as defined in figure 23-18 during reception of test signal defined in figure 23-19	23.5.1.3.3	M		Less than 6%
PME42	Receiver common-mode rejection; effect of E_{cm} as shown in figure 23-24	23.5.1.3.4	M		Receiver meets 23.5.1.3.1
PME43	E_{cm} used for common-mode rejection tests	23.5.1.3.4	M		25 V peak-to-peak square wave, 500 kHz or lower in frequency, with edges no slower than 4 ns
PME44	Receiver faults; response to indefinite application of short circuits	23.5.1.3.5	M		Withstand without damage and resume operation after fault is removed
PME45	Receiver faults; response to 1000 V common mode impulse per IEC 60	23.5.1.3.5	M		Withstand without damage
PME46	Shape of impulse used for common mode impulse test	23.5.1.3.5	M		0.3/50 μ s as defined in IEC 60
PME47	Receiver properly receives data have a worst-case ternary symbol range	23.5.1.3.6	M		25.00 MHz \pm 0.01%
PME48	Steady-state current consumption	23.5.2	MII:M		0.75 A maximum
PME49	PHY operating voltage range	23.5.2	MII:M		Includes worst voltage available from MII
PME50	Extraneous signals induced on the MII control circuits during normal power-up and power-down	23.5.2	M		None

23.12.4.14 Characteristics of the link segment

Item	Feature	Subclause	Status	Support	Value/Comment
LNK1	Cable used	23.6.1	INS:M		Four pairs of balanced cabling, Category 3 or better, with a nominal characteristic impedance of 100 Ω
LNK2	Source and load impedance used for cable testing (unless otherwise specified)	23.6.2	INS:M		100 Ω
LNK3	Insertion loss of simplex link segment	23.6.2.1	INS:M		Less than 12 dB
LNK4	Source and load impedances used to measure cable insertion loss	23.6.2.1	INS:M		Meet 23.5.1.2.4 and 23.5.1.3.3
LNK5	Characteristic impedance over the range 2–12.5 MHz	26.6.2.2	INS:M		85–115 Ω
LNK6	NEXT loss between 2 and 12.5 MHz	23.6.2.3.1	INS:M		Greater than $24.5 - 15 \log\left(\frac{f}{12.5}\right)$ dB
LNK7	MDNEXT loss between 2 and 12.5 MHz	23.6.2.3.2	INS:M		Greater than $21.4 - 15 \log\left(\frac{f}{12.5}\right)$ dB
LNK8	ELFEXT loss between 2 and 12.5 MHz	23.6.2.3.3	INS:M		Greater than $23.1 - 15 \log\left(\frac{f}{12.5}\right)$ dB
LNK9	MDELNEXT loss between 2 and 12.5 MHz	23.6.2.3.4	INS:M		Greater than $20.9 - 15 \log\left(\frac{f}{12.5}\right)$ dB
LNK10	Propagation delay	23.6.2.4.1	INS:M		Less than 570 ns
LNK11	Propagation delay per meter	23.6.2.4.2	INS:M		Less than 5.7 ns/m
LNK12	Skew	23.6.2.4.3	INS:M		Less than 50 ns
LNK13	Variation in skew once installed	23.6.2.4.3	INS:M		Less than ± 10 ns, within constraint of LNK8
LNK14	Noise level	23.6.3	INS:M		Such that objective error rate is met
LNK15	MDNEXT noise	23.6.3.1	INS:M		Less than 325 mVp
LNK16	MDFEXT noise	23.6.3.2	INS:M		Less than 87 mVp
LNK17	Maximum length of Category 5, 25-pair jumper cables	23.6.3.2	INS:M		10 m

23.12.4.15 MDI requirements

Item	Feature	Subclause	Status	Support	Value/Comment
MDI1	MDI connector	23.7.1	M		IEC 603-7: 1990
MDI2	Connector used on PHY	23.7.1	M		Jack (as opposed to plug)
MDI3	Crossover in every twisted-pair link	23.7.2	INS:M		
MDI4	MDI connector that implements the crossover function	23.7.2	XVR:M		Marked with "X"

23.12.4.16 General safety and environmental requirements

Item	Feature	Subclause	Status	Support	Value/Comment
SAF1	Conformance to safety specifications	23.9.1	M		IEC 950: 1991
SAF2	Installation practice	23.9.2.1	INS:M		Sound practice, as defined by applicable local codes
SAF3	Any safety grounding path for an externally connected PHY shall be provided through the circuit ground of the MII connection	23.9.2.2	M		
SAF4	Care taken during installation to ensure that noninsulated network cable conductors do not make electrical contact with unintended conductors or ground	23.9.2.3	INS:M		
SAF5	Application of voltages specified in 23.9.2.4 does not result in any safety hazard	23.9.2.4	M		
SAF6	Conformance with local and national codes for the limitation of electromagnetic interference	23.9.3.1	INS:M		

23.12.4.17 Timing requirements

Item	Feature	Subclause	Status	Support	Value/Comment
TIM1	PMA_OUT	23.11.3	PMA:M		1 to 9.5 BT
TIM2	TEN_PMA + PMA_OUT	23.11.3	PCS:M		7 to 17.5 BT
TIM3	TEN_CRS	23.11.3	PCS:M		0 to +4 BT

Item	Feature	Subclause	Status	Support	Value/Comment
TIM4	NOT_TEN_CRS	23.11.3	PCS:M		28 to 36 BT
TIM5	RX_PMA_CARRIER	23.11.3	PMA:M		Less than 15.5 BT
TIM6	RX_CRS	23.11.3	PCS:M		Less than 27.5 BT
TIM7	RX_NOT_CRS	23.11.3	PCS:M		0 to 51.5 BT
TIM8	FAIRNESS	23.11.3	PCS:M		0 to 28 BT
TIM9	RX_PMA_DATA	23.11.3	PMA:M		67 to 90.5 BT
TIM10	EOP_CARRIER_STATUS	23.11.3	M		51 to 74.5 BT
TIM11	EOC_CARRIER_STATUS	23.11.3	M		3 to 50.5 BT
TIM12	RX_RXDV	23.11.3	PCS:M		81 to 114.5 BT
TIM13	RX_PMA_ERROR	23.11.3	M		Allowed limits equal the actual RX_PMA_DATA time for the device under test plus from 0 to 20 BT
TIM14	RX_COL	23.11.3	PCS:M		Less than 27.5 BT
TIM15	RX_NOT_COL	23.11.3	PCS:M		Less than 51.5 BT
TIM16	TX_NOT_COL	23.11.3	PCS:M		Less than 36 BT
TIM17	TX_SKEW	23.11.3	M		Less than 0.5 BT
TIM18	CRS_PMA_DATA	23.11.3	PMA:M		Less than 78.5 BT
TIM19	COL_to_BI_D3/4_OFF	23.11.3	PMA:M		Less than 40 BT

This is an Archive IEEE Standard. It has been superseded by a later version of this standard.

24. Physical Coding Sublayer (PCS) and Physical Medium Attachment (PMA) sublayer, type 100BASE-X

24.1 Overview

24.1.1 Scope

This clause specifies the Physical Coding Sublayer (PCS) and the Physical Medium Attachment (PMA) sublayer that are common to a family of 100 Mb/s Physical Layer implementations, collectively known as 100BASE-X. There are currently two embodiments within this family: 100BASE-TX and 100BASE-FX. 100BASE-TX specifies operation over two copper media: two pairs of shielded twisted-pair cable (STP) and two pairs of unshielded twisted-pair cable (Category 5 UTP).²¹ 100BASE-FX specifies operation over two optical fibers. The term 100BASE-X is used when referring to issues common to both 100BASE-TX and 100BASE-FX.

100BASE-X leverages the Physical Layer standards of ISO 9314 and ANSI X3T12 (FDDI) through the use of their Physical Medium Dependent (PMD) sublayers, including their Medium Dependent Interfaces (MDI). For example, ANSI X3.263: 199X (TP-PMD) defines a 125 Mb/s, full-duplex signaling system for twisted-pair wiring that forms the basis for 100BASE-TX as defined in clause 25. Similarly, ISO 9314-3: 1990 defines a system for transmission on optical fiber that forms the basis for 100BASE-FX as defined in clause 26.

100BASE-X maps the interface characteristics of the FDDI PMD sublayer (including MDI) to the services expected by the CSMA/CD MAC. 100BASE-X can be extended to support any other full duplex medium requiring only that the medium be PMD compliant.

24.1.2 Objectives

The following are the objectives of 100BASE-X:

- a) Support the CSMA/CD MAC.
- b) Support the 100BASE-T MII, repeater, and optional Auto-Negotiation.
- c) Provide 100 Mb/s data rate at the MII.
- d) Support cable plants using Category 5 UTP, 150 Ω STP or optical fiber, compliant with ISO/IEC 11801: 1995.
- e) Allow for a nominal network extent of 200–400 m, including:
 - 1) unshielded twisted-pair links of 100 m;
 - 2) two repeater networks of approximately 200 m span;
 - 3) one repeater networks of approximately 300 m span (using fiber); and
 - 4) DTE/DTE links of approximately 400 m (using fiber).
- f) Preserve full-duplex behavior of underlying PMD channels.

24.1.3 Relationship of 100BASE-X to other standards

Figure 24-1 depicts the relationships among the 100BASE-X sublayers (shown shaded), other 100BASE-T sublayers, the CSMA/CD MAC, and the IEEE 802.2 LLC.

24.1.4 Summary of 100BASE-X sublayers

The following provides an overview of the 100BASE-X sublayers that are embodied in the 100BASE-X Physical sublayer (PHY).²²

²¹ISO/IEC 11801: 1995 makes no distinction between shielded or unshielded twisted-pair cables, referring to both as balanced cables.

²²The 100BASE-X PHY should not be confused with the FDDI PHY, which is a sublayer functionally aligned to the 100BASE-T PCS.